

LIBRARY  
OF THE  
UNIVERSITY  
OF ILLINOIS

620.5

TH

v. 78

cop. 2

REMOTE STORAGE









le 3 Jt

ILLINOIS

23

# TECHNOGRAPH

No. 1 — 25¢

NOV 2 1962  
UNIVERSITY OF ILLINOIS







**Editor-in-Chief**  
Wayne Crouch

**Associate Editor**  
Gary Daymon

**Business Manager**  
Charlie Adams

**Production Manager**  
Scott Weaver

**Circulation Manager**  
Gary Bilow

**Editorial Assistant**  
Thelma Allen

**Editorial Staff**  
Art Becker  
Larry Druffel  
Ted Morange  
Bill Small  
James Walters

**Business Staff**  
Phillip Johnson

**Production Staff**  
Mike Glowacz

**Circulation Staff**  
Dave Dudek

**Photography**  
Jay Dickinson  
Joe Figueira

**Advisors**  
R. W. Bohl  
P. Bryant  
W. M. Hudson  
E. C. McClintock

# THE ILLINOIS TECHNOGRAPH

Volume 78; Number 1

October, 1962

## Table of Contents

### ARTICLES

Illini Engineers in Industry Quality and the Engineer .....	Calvin Evans	10
Requirements Change in Engineering .....	Edward C. Wahl	14
To Tell the Truth (Fiction) .....	Larry Bal'den	26
Educators Confer on Mechanical Technology ..	Larry Druffel	32

.....

### FEATURES

TECH Says .....		5
The Dean Speaks .....	Dean H. L. Wakeland	7
News and Views at the University of Illinois .....		20
Technocutie .....	Photos by Andrew Giel	22
Skimming Industrial Headlines .....	Art Becker	33
Begged, Borrowed, and . . . ..		38

### MEMBERS OF ENGINEERING COLLEGE MAGAZINES ASSOCIATED

Chairman: Charles E. Wales  
Wayne State University, Detroit, Michigan

Arkansas Engineer, Cincinnati Cooperative Engineer, City College Vector, Colorado Engineer, Cornell Engineer, Denver Engineer, Drexel Technical Journal, Georgia Tech Engineer, Illinois Technograph, Iowa Engineer, Iowa Transit, Kansas Engineer, Kansas State Engineer, Kentucky Engineer, Louisiana State University Engineer, Louisiana Tech Engineer, Manhattan Engineer, Marquette Engineer, Michigan Technic, Minnesota Technologist, Missouri Shamrock, Nebraska Blueprint, New York University Quadrangle, North Dakota Engineer, Northwestern Engineer, Notre Dame Technical Review, Ohio State Engineer, Oklahoma State Engineer, Pittsburgh Skyscraper, Purdue Engineer, RPI Engineer, Rochester Indicator, SC Engineer, Rose Technic, Southern Engineer, Spartan Engineer, Texas A & M Engineer, Washington Engineer, WSC Technometer, Wayne Engineer, and Wisconsin Engineer.

### The Cover:

Although the cover painting has Gestalten overtones, its context here is as a conscience. That is, very little is known about many things while the whole or a number of the parts may be readily defined. The reader will note certain forms in the painting with which he is familiar if he alternately "sees" the darks—then the lights—as objects. The purpose of this magazine is, in part, to make intelligible more of the unknown areas.

Copyright, 1962, by Illini Publishing Co. Published eight times during the year (October, November, December, January, February, March, April and May) by the Illini Publishing Company. Entered as second class matter, October 30, 1920, at the post office at Urbana, Illinois, under the Act of March 3, 1879. Office 215 Engineering Hall, Urbana, Illinois. Subscriptions \$1.50 per year. Single copy 25 cents. All rights reserved by *The Illinois Technograph*. Publisher's Representative: Littell-Murray-Barnhill, Inc., 737 North Michigan Avenue, Chicago 11, Ill., 369 Lexington Ave., New York 17, New York.

# HOW CUTLER-HAMMER CREATIVE ENGINEERING HELPS INDUSTRY REACH ITS AUTOMATION GOALS

*Ralph Millermaster, vice president,  
engineering and development, answers the questions  
most frequently asked by students regarding  
Cutler-Hammer's role in industrial automation*



## **Q. How long has Cutler-Hammer been in Automation?**

**A.** Long before the word "automation" was coined.

Many company historians view the installation of the first electric turret-turning control for battle-ships as our original "automatic system" achievement. In 1904, trials aboard the U.S.S. INDIANA so improved rapid-fire and gunnery-control scoring that identical systems were installed on sister ships.

## **Q. How does your Automation—or "System Control"—effort differ from your other control business?**

**A.** We work in two areas of control. One involves research, development and manufacture of standardized electric control components and apparatus. Here the customer orders from us through a bill of material.

The automation customer is different. He has no bill of material—he has a problem. He needs to improve production or quality, or to reduce his unit costs. He isn't buying "hardware," he's seeking a creative solution to a challenging problem . . . and that's what our engineers provide.

## **Q. Assuming I decide to work for a control manufacturer, why Cutler-Hammer?**

**A.** The most compelling reason is our continuing interest and extensive experience in "System Control." This is the life of our company and distinct career advantages result from this concern.

Our engineers are forced to apply a combination of advanced electronic and electrical engineering

know-how to solve a customer's manufacturing problem. They start with a thorough grounding in the customer's products—how he moves and works the materials he manufactures. Then they apply their technical knowledge to create a practical solution. We have a Materials Handling group, a Metal Processing group, and many other industry groups composed of young, creative-minded engineers.

And, we don't "stock-pile" our engineering talent. Every engineer we hire is expected to contribute quickly and directly to the team effort.

## **Q. How does Cutler-Hammer approach an automation job?**

**A.** We have learned that a sizable system needs painstaking coordination between many groups—project teams, engineering, maintenance and purchasing personnel at the customer factory and headquarters locations . . . machinery builders, motor manufacturers, contractors and many more.

We view this coordination as one of our primary functions, and fulfill it by furnishing all responsible groups and individuals the information they want and need to guarantee an efficient dovetailing of effort.

We organize a coordinating task force for each project, headed by a lead engineer and staffed by engineers representing every necessary technical discipline. That task force is charged with three duties:

1. Create a system that will solve the problem.
2. Design the system within the time allotted.
3. Install the system at a cost which pays its way for the customer and provides us a fair profit.

Task forces work together in a modern 500,000 square foot plant specifically designed to house every activity involved in the evolution of the complete system. Every possible step has been taken to provide a climate that is conducive to creative planning and development.

This approach has paid off! Long recognized as a leader in standardized motor control, Cutler-Hammer is more and more being regarded as a major contributor in industrial automation. Our automation credentials include innovations in every industrial field from continuous process lines to newspaper mail rooms.

## **Q. How do I learn more about Cutler-Hammer's automation capability and the career opportunities for engineers?**

**A.** By visiting your Placement Office . . . picking up the Cutler-Hammer literature on the rack, and talking to your Placement Director. Or, you can write direct to T. B. Jochem, Cutler-Hammer, Milwaukee, Wisconsin, for a complete kit of information. And, I hope that you will plan to meet with our representative when he visits your campus.

WHAT'S NEW FOR YOU? ASK...

## **CUTLER-HAMMER**

Cutler-Hammer Inc., Milwaukee, Wisconsin • Divisions: AIL, Mullerbach • Subsidiaries: Uni-Bus, Inc.; Cutler-Hammer International, C.A. Associates: Cutler-Hammer Canada, Ltd.; Cutler-Hammer, Mexicana, S.A.





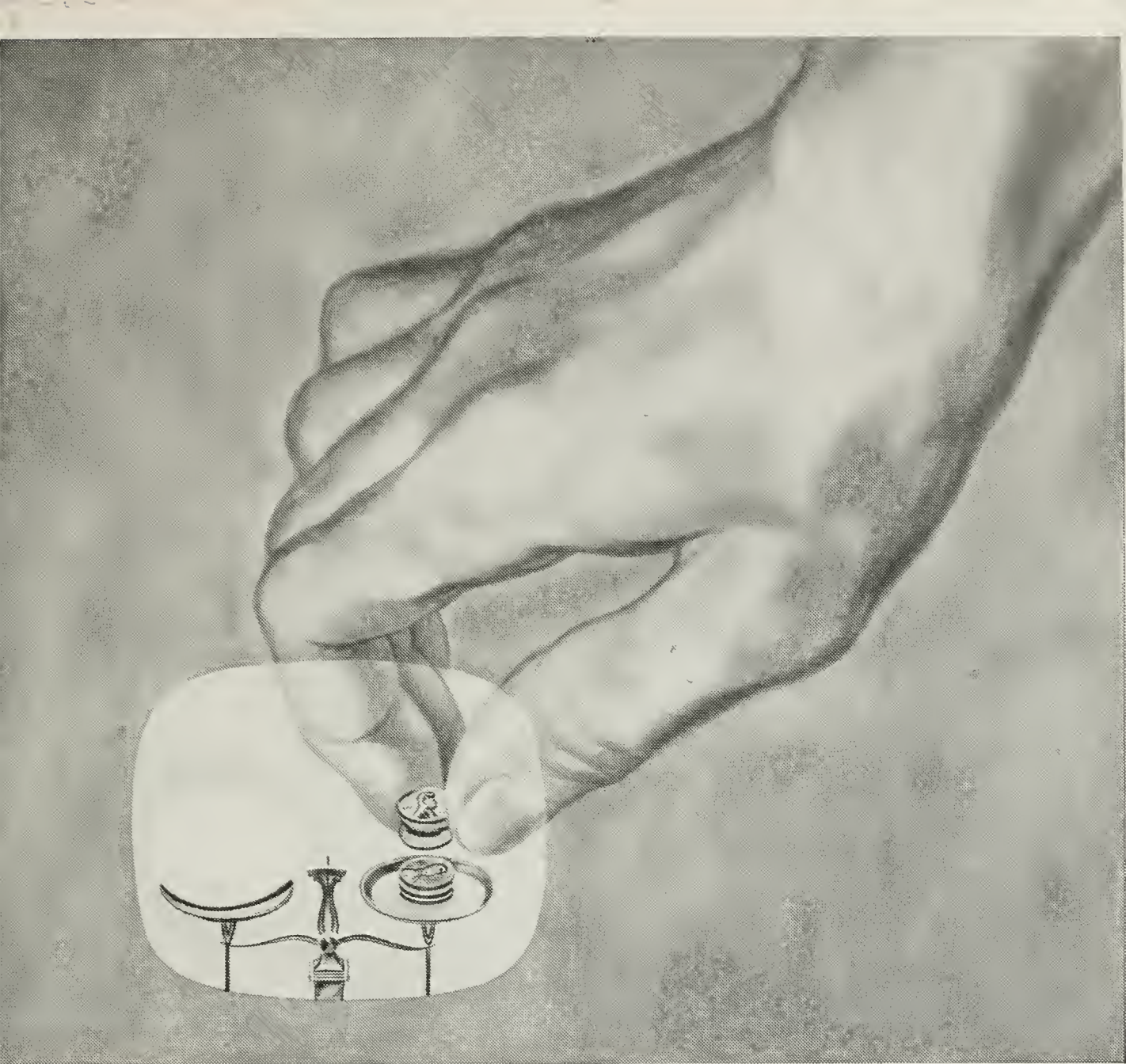

## Let's look at the price of eggs

What did you pay for eggs this week? Probably a little more or a little less than last week. Prices of things go up and down because of many factors . . . such as supply and demand, wages, materials and shipping costs, and needed profits. It all gets more complex when you consider taxes and competition, or compare our economy to that of other countries. ► Now millions of people can learn more about economics from a stimulating series of television programs on *The American Economy*. Conducted by leading educators and economists, "College of the Air" will describe how our economic system works . . . how it provides stability and growth . . . how it enhances individual freedom. Starting this fall, *The American Economy* will appear on the CBS television network as five one-half hour programs per week for 32 weeks . . . equal to two semesters of college classes. ► With the belief that only through broader education can we meet the growing needs of tomorrow, American business is giving financial support to "College of the Air." The people of Union Carbide are proud to be among the donors to such a worthwhile project.

A HAND IN THINGS TO COME

**UNION  
CARBIDE**

*COLLEGE CREDIT will be given by many colleges for The American Economy. For names of participating colleges and local viewing times, write Union Carbide Corporation, 270 Park Avenue, New York 17, N.Y.*



ELECTRONICS  
ENGINEERS  
& PHYSICISTS:

## If space is your future, your career is with Hughes

IN ASTROSPACE  
IN AEROSPACE  
IN TERRASPACE  
IN HYDROSPACE

As far back as 1890, Jules Verne visualized excursion trains to the moon. Today — 72 years later — Hughes offers you the opportunity to play an important part in man's actual conquest of space.

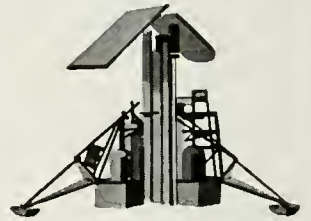

Help us soft-land the SURVEYOR on the moon — or work with us on exciting advanced projects such as:

**ANTI-MISSILE DEFENSE**  
**SYNCOM (Communications satellite)**  
**PLASMA PHYSICS & ION PROPULSION**  
**ADVANCED FIXED-ARRAY RADAR SYSTEMS**  
**LASER & MASER RESEARCH & DEVELOPMENT**  
**NUCLEONICS & MOBOT\* SYSTEMS**  
**SOLID STATE MATERIALS & DEVICES**  
**DATA PROCESSING & COMMAND-CONTROL**

**B.S., M.S. and Ph.D. Candidates**

Members of our staff will conduct

### CAMPUS INTERVIEWS

**November 6 and 7, 1962**

Find out more about the wide range of activities, educational programs and relocation allowances offered by Hughes.

For interview appointment or informational literature consult your College Placement Director. Or write: *College Placement Office, Hughes, P.O. Box 90515, Los Angeles 9, Cal*

Creating a new world with ELECTRONICS

# HUGHES

HUGHES AIRCRAFT COMPANY  
An equal opportunity employer.

\*Trademark Hughes Aircraft Company

Bettman Archive



*Preserve Campus Tradition . . .*

# NO SMOKING

***Few traditions have touched TECH so deeply as this one. Beware ye fag fiends . . . TECH is crusading***

In this day when law breaking, in some forms at least, is looked upon by a great many as a clever, admirable and daring accomplishment, and is becoming the common practice of the same many, it is little wonder that one of our campus traditions—an unwritten law—should come in for its share of flagrant violations. Yet, how decidedly “unclever,” “unadmirable,” and “undaring” it is to violate a campus tradition.

Unlike the civil law, there is no policeman to enforce a campus tradition; there is no penalty for its violation. Hence there is no one to put wit and no one’s eyes “to pull the wool over,” so that in no way is there anything admirable in the deed. It reminds one of the person who cautiously looks around to see if he is being observed before cheating in a game of solitaire. We laugh at such a person for he is cheating no one but himself; yet, how little different is his action from that of a student who

thinks how brazen and lawless he is because he breaks a rule that he is supposed to enforce when he smokes on the campus.

This semester there has been a continual growth in the number of men who smoke on the campus. Evidently there is little regard for this one distinctive tradition of our campus, and unless student spirit changes at once, the traditions will be but a memory.

The engineers have been as guilty as any others in smoking on the campus, and despite efforts to stop it, open violation of the tradition continues. Remember engineers, that as students of the University, the tradition is yours. It is up to each and every engineer to uphold and further it. This can be best done by not smoking on the campus, and by discouraging others from smoking on the campus. Remember, no one admires a man who cheats at solitaire.

*(Reprinted from the Editorial page of the May 1924 Technograph)*

IS YOUR  
FUTURE  
WORTH A  
20 MINUTE  
INTERVIEW?



If you are about to decide on your future employment and are graduating with outstanding scholastic achievement in engineering or the physical sciences . . . the Sandia Corporation would like to arrange an interview with you.

At Sandia, you would work in research, design and development, or engineering. Our scientists and engineers are engaged in projects in the fields of solid state physics, plasma physics, materials research, explosives technology, pulse phenomena and radiation damage.

You would work in a modern well-equipped \$120 million laboratory and be associated with some of this

nation's outstanding technical personnel. You would receive liberal benefits which, in addition to insurance, retirement and vacation, include an opportunity for continuing your graduate studies.

You would be employed in sunny, dry Albuquerque, a Southwestern cultural center of over 250,000, or in our laboratory at Livermore, California, with all the advantages of the San Francisco Bay area.

**Electrical and Mechanical Engineers at all Degree Levels**

**At MS and PhD Levels**  
Aeronautical Engineers  
Ceramic Engineers  
Chemical Engineers

**Industrial Engineers**  
**Chemists**  
**Mathematicians**  
**Physical Metallurgists**  
**Physicists**  
**Engineering Physicists**  
**Statisticians**

Sandia Corporation recruiters will be on your campus soon.\* For appointment for interview, see your College Placement Officer now.

Equal Opportunity Employer

**SANDIA**  
CORPORATION



ALBUQUERQUE, NEW MEXICO  
LIVERMORE, CALIFORNIA

\*The Sandia representative will be on campus Oct. 23-24.

# STUDENT RATINGS

by

ENGINEERING FACULTY

By Dean H. L. Wakeland

For a number of years the staff members in the College of Engineering have made personal ratings on each of the upperclass students they have in class. A composite of these personal ratings then becomes a part of each graduating senior's permanent college record although it does not appear on his transcript.

Staff members are asked to rank the students on the basis of personal characteristics such as personality, judgment, industry, initiative, leadership, cooperation, appearance and self-control and are asked to give any other remarks they may have about the student. The College of Engineering had never intended to perform this function in secret or without the students awareness of what was being done. However, through the years the procedure was commonly accepted. Since a continued effort has not been made to inform students about this function, many did not realize it was being done. Any student may see the personal ratings given him upon request.

When a prospective employer is seeking information about an engineering graduate, such personal information is important to both the employer and the employee. Though this practice has been in effect for a number of years, some students last year questioned the desirability, fairness and appropriateness of such a system. Apparently they felt that it was an invasion of their privacy and the University should be concerned only with their academic record.

The goal of any university is to educate a student and not simply to graduate a "facts man" or a "thinker without direction." If the student hasn't gained a respect for those about him, if he hasn't achieved reasonable judgment, if he hasn't learned to work with others, if he hasn't learned to use his knowledge for the betterment of society—he is not truly educated. These traits cannot be taught directly in the classroom but must be taught indirectly there, as well as in student activities and campus living. The university cannot guarantee that each graduate possesses these traits, but certainly has the responsibility and right to observe the student's performance and general attitude.

All too often we read of highly educated persons, placed in positions of trust and responsibility, committing dishonest and dishonorable acts. Recent cases cited of scientists being disloyal to the United States Government and engineers involved in price fixing scandals point out what may happen if college graduates lack the desirable characteristics normally expected. Not only did they fail as individuals in their respective positions, but the persons or society which allowed them to gain such positions also failed in judging them as individuals.

We each are judged daily by our employer, our neighbors, our fellow workers, and we in turn select leaders in all phases of our lives—in industry, in our community, and in politics—on the basis of our judgment. Is it so surprising that the University would wish to make a record of students' personal characteristics or that a prospective employer would appreciate the benefit of someone else's judgment.

Perhaps the worst recommendation a student could have would be if the school from which he graduated had no record of him at all. If a prospective employer should ask about a graduate and be told that no staff member knew him or remembered him, the employer might immediately conclude that the student was either a poor student or an introvert. If, on the other hand, the employer receives a prompt answer giving the student's personal characteristics and academic record, the employer should be favorably impressed.

In addition, a student should realize that his actions are being judged by others each day and should always put forth his best. Many of the student's college day acquaintances and experiences are lasting and the impression he leaves may linger for some time. Students rely upon their college professors for recommendations for several years after graduation and should conduct their personal lives in such a manner as to warrant a decent recommendation.

Employment surveys have shown time and again that the greatest cause for people losing their jobs is a lack of personal characteristics—such as personality, judgment, willingness to cooperate, and attitude—as compared with lack of mental ability or calibre.

The student body should also realize that personal evaluation is a two-way street, and they too have an opportunity to judge staff members. Recently, one of the housing groups initiated a program to rate staff members as instructors. Such a program would not only be welcomed but could be quite useful in improving our level of teaching. We can all profit thru the criticism and evaluations others make of us if we take such criticism in a constructive manner. ◆◆◆





Wheat seedlings fertilized with Phillips 66 Agricultural Ammonia

**Interested in Growth?** Phillips is . . . agriculturally, as the oil industry's largest producer of nitrogen fertilizers. And Phillips is interested in growth as a highly diversified oil company that is actively engaged in such growth enterprises as petrochemicals and atomic energy. Phillips is also one of the fastest growing marketers of gasoline, motor oil and other petroleum products. It leads the oil industry in the sale of natural gas, the production of natural gas liquids, and is the world's largest producer-marketer of liquefied petroleum gas. In addition, Phillips leads the oil industry in the production of polyolefin plastics, and is a major supplier of synthetic rubber and oil furnace carbon black, hydrocarbon chemicals and raw materials for plastics.

Because of this continuing growth and leadership in numerous fields of endeavor, you will find many outstanding career opportunities with Phillips Petroleum Company. There are many opportunities in research and development for engineers, chemists and physicists. Excellent opportunities also exist in geophysics, geology, petroleum production, transportation, refining, marketing and computer programming. Phillips Petroleum Company aggressively pursues a

policy of upgrading petroleum raw materials by making a wide range of chemicals from petroleum, thus the potential for new opportunities with this company is virtually unlimited.

Qualified college graduates will find working for Phillips an exciting and rewarding experience. New and significant developments . . . important research discoveries . . . new oil and gas fields, new plants, added marketing areas create demands for personnel qualified to assume added responsibilities and move forward in this dynamic company.

Phillips is an equal opportunity employer. For full details, write to our Employee Relations Department. Arrangements for an interview with a Phillips Representative can be made through your College Placement Office.



**PHILLIPS PETROLEUM COMPANY**  
Bartlesville, Oklahoma



## Your future in chemical engineering is his business

He's a Monsanto Professional Employment representative. He's *your* representative, too . . . your link between campus and company. His knowledge of Monsanto is complete, and he's especially qualified to counsel with you regarding your future.

Ask him about Monsanto's diversity—in geography, activities, products—that means ever-expanding opportunity for the young man of exceptional promise. Ask him about Monsanto's research-mindedness, how it helps develop your creativity. Ask this expert in

*futures* about the future Monsanto offers *you* in research, engineering, manufacturing and marketing.

See your Placement Director to arrange an interview when we visit your campus soon. Or write for our new brochure, "You, Your Career and Monsanto," to Professional Employment Manager, Department EM-3, Monsanto Chemical Company, St. Louis 66, Missouri.



®

ALL QUALIFIED APPLICANTS WILL RECEIVE CONSIDERATION WITHOUT REGARD TO RACE, CREED, COLOR OR NATIONAL ORIGIN



# ILLINI ENGINEERS

in

## INDUSTRY

edited by: Larry Druffel

During the summer months, many Illini engineering students spent their vacations learning as well as earning. The primary purpose of anyone's summer employment, of course, is to prepare for the ensuing financial draught of the school year. Some of the more fortunate and enterprising Illini dared to steal an early glimpse of the future waiting beyond the "halls of ivy." Slide rules in hand, they ventured from the classroom to the drawing board and returned richer intellectually, as well as financially.

After three experience filled months the Illini have come back refreshed. Courses once considered dull are taking on new interest. Futures are less uncertain. School has a new meaning.

As graduation approaches, seniors often find certain anxieties about the world beyond the campus. What does industry expect of engineering graduates? What courses represent the best preparation for engineering work? What phase of engineering should I enter? These are the questions that plague every engineering graduate. The answers are found in that familiar old school of experience.

For some, the last summer vacation has come and gone, and with it, the chance to answer those pre-graduation questions before decisions must be made. For the many who lack the experience upon which these decisions should be based, there are other sources of information. Friendly professors are always available for advice. Books, interviewers, and friends in industry round out the secondary sources of information.

To that short list, add the TECHNOGRAPH! A series of articles will appear in subsequent issues of TECHNOGRAPH under the title of "Illini Engineers in Industry." The articles will be written by friends of yours, junior and senior engineering students who were fortunate enough to find summer employment in their chosen profession. The articles will cover many of the various phases of engineering in which fellow Illini worked this past summer. Each will explain the type of work he performed. The articles will carry valuable information for engineering students because they will be written by people who, through experience, have answered for themselves the same questions you are asking yourself. Articles have been written by engineers who have worked in design, sales, development, manufacturing, writing, quality control, and management. Through their experience, you have the opportunity to learn what each type of engineering entails. Through the observations of students just like you, comes information on which one of the most important decisions in your life can be based. ♦♦♦

## *Quality and the Engineer*

b  
y  
  
C  
A  
L  
V  
I  
N  
  
E  
V  
A  
N  
S

What is the engineer's relationship to quality in industry? Why should you, a potential engineer, have any concern for quality problems in industry?

In reality every engineer is a quality engineer. True, the sign on your door may never read "Quality Control Engineer," but it is still your job. Whether you are in design, sales, production, writing, or management, you will be concerned with quality. You, as an engineer, will be hired to find a better way of doing the job.

Regardless of the amount of ingenuity you may use, the finished product, whether it is a process, a piece of equipment, or merely an idea, must possess sufficient quality to meet existing competition. To merit consideration, your product must possess sufficient quality to effectively and efficiently do the job.

Whether you are aware of it or not, you have learned a similar lesson in college. Quality is the only guarantee of a successful academic standing. If you forget the lesson of quality, you may as well forget your formulas, slide rule,



and theories. You are not going to sell your product unless it is a quality product.

### Quality Control and Its Function

But what is quality? What does quality control contribute to industry? These are questions which come to mind when one is first introduced to quality in industry. One type is termed *design quality*, which is bred into the product by engineering personnel who design it. This includes the specified tolerances, types of material used, and any special handling that may be requested. Another type is *production quality*, which is obtained or obtainable on the production floor. This includes the capability of the machine and operator as well as an inspection of each phase of production.

Often the student, who is far removed from the industrial scene, assumes that everything he designs will be produced exactly to his specifications. Unfortunately, this is only an idealistic view. Hence, the need has arisen for a quality control program which will enforce the specifications and insure that the product is acceptably close to the original design. There is, needless to say, an ever present conflict between the cost and value of quality. Many situations arise where a small increase in quality is far overshadowed by the corresponding increase in cost. Understandably, the optimum point is always short of perfection.

### Inspection Procedures

Regardless of the particular method involved, quality control exists for one primary reason—to assure the company of a quality product. One of the methods used is *inspection procedures*. The best place to begin an attack on inferior quality is at the receiving department of the plant. Obviously, a product can be no better than the materials used. One way of determining the quality level maintained by the supplier is a periodic examination of the vendor's facilities. Such an examination is usually welcomed by the vendor since it helps him determine whether or not his facilities meet the established standards. This procedure, however, will only give information concerning the quality that the vendor is capable of attaining, and a receiving inspection is necessary to insure that the vendor is maintaining this standard.

An accepted way of sampling incoming orders is to follow the inspection plans given in the appropriate manuals on the subject. Such a manual that is widely used is MIL-STD 105A, "Sampling Procedures and Tables for Inspection by Attributes." This type of manual lists the percentage of units that must be sampled and the maximum percentage of defects that are allowable to maintain the desired acceptable quality level (AQL).

Another method of inspection that is necessary to maintain quality is *process inspection*. The quality control department determines the points in the work flow where the product should be inspected and the specific checks required. If the lots submitted for inspection are rejected, the quality control and production departments must work together to decide whether to scrap or salvage the lot. There must be a predetermined AQL to provide an acceptable unit cost and quality level.



*Cal, a senior in Electrical Engineering, worked in the Quality Control Department of the International Resistance Company of Burlington, Iowa. He has also worked part time at the University Antenna Lab and for the TAM department. During his junior year, he served as Secretary of the AIEE-IRE student branch.*

### Statistical Quality Control

A second method of quality control is entitled *statistical quality control*, and consists of *process control*, *acceptance techniques*, and *special job studies*. This is the primary theory behind all quality work, and it is concerned largely with probability.

Process control is becoming a more significant factor in quality control as industry continues to become more mechanized. If a modern high speed process goes out of control, major losses can result in a matter of minutes. Because the cost of such machines is significantly higher than pre-automated equipment, keeping the process steadily in operation and under precise control has become increasingly important.

One accepted technique for process control evaluation is the use of a control

chart. This chart is used to record and give a day-by-day, hour-by-hour, or piece-by-piece account of what is being produced. A control chart is a plot of a particular dimension or value for a sample of  $n$  units versus time, and a plot of the span of these  $n$  units versus time. In general, there must be at least twenty samples of three to five units per sample to give an accurate chart. Control limits are established for the process and the plot will stay within these limits if it is in control and has only random variance. The control limits are tolerance, type of processes involved, and the required quality level. The control chart will also show any drift tendency that the process may have.

Another technique useful in process control is *acceptance sampling*. This was previously mentioned in relation to inspection of vendor materials. One sampling plan, of course, would be to give everything a one-hundred per cent check. This obviously would be too costly and often destructive. Another possibility is to have a *roving inspector* on the production floor. However, this proves to be a hit and miss procedure, and there seems to be no means of adequate control. Use of the previously mentioned AQL tables is without a doubt the most accurate and consistent method of determining exactly what the process is doing.

### Reliability

A new phase of quality control has been added to industry in the past few years—that of *reliability*. Reliability has followed the increase in automated products along with their corresponding complexities. Reliability is the probability that a particular product will function properly.

The factors of reliability are performance, time, and environment. In short, will it work over a given length of time in a particular environment? Reliability is not a one stop check made on each item before it leaves the plant, but rather it involves many performance hours under environmental conditions. It may mean a careful analysis of all failures that are found in testing, as well as all those that are reported from the field. To insure reliability constant checks must be made by the quality control department. Many customers insist upon elaborate reliability data before they accept a product.

This, then, is quality engineering. Every engineer must be fully aware of it. Although in college it is easy to neglect the economic aspect of engineering, the fact remains that a practicing engineer must realistically face quality and cost problems. The sooner a graduate becomes aware of these factors, the sooner his prestige and the company's profits will begin to grow. ♦♦♦



# Engineers

*In Choosing a Career,  
Consider these  
Advantages—*

**Location:** Fisher is basically an "Engineering" company with 1,500 employees located in a pleasant midwest community of 22,000. It's less than 10 minutes to the Fisher plant from any home in Marshalltown.

**Type of work:** You'll become a member of an engineering team that has produced some of the outstanding developments in the field of automatic pressure and liquid level controls.

**Growth:** Fisher's products are key elements in automation which assures the company's growth because of the rapid expansion of automation in virtually every industry.

**Advancement:** Your opportunity is unlimited. It is company policy to promote from within; and most Fisher department heads are engineers.

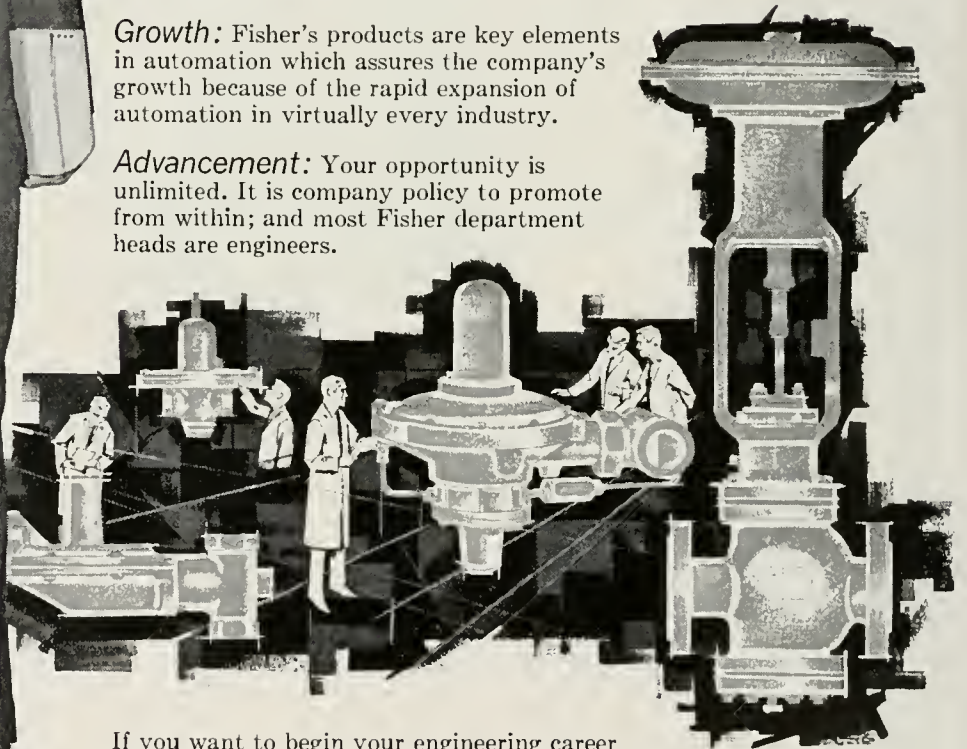

If you want to begin your engineering career with one of the nation's foremost research and development departments in the control of fluids, consult your placement office or write directly to Mr. Cecil Johnson, Chief Engineer, FISHER GOVERNOR COMPANY, Marshalltown, Ia.

*If it flows through pipe  
anywhere in the world  
chances are it's controlled by...*







*A short talk  
about a lifetime career*

by *Jim Bryce*

"Here in the research department of American Oil you're given an opportunity to work in many phases of petroleum engineering. As a design-economics engineer, I'm investigating the incentives for proposed new technical ventures. These projects provide a good background for greater research department responsibilities and or for opportunities in marketing, production, or general management."

Jim Bryce has a lot going for him: a Bachelor of Chemical Engineering degree from Cornell, an excellent start on his Masters degree in Business Administration in Finance at Northwestern, and a solid career opportunity at American Oil. Right now, Jim's MBA work at Northwestern is being paid for (75%) by American Oil on their Advanced Education Plan.

Scores of ambitious and talented young men like Jim Bryce have been attracted to American Oil because of the wide range of research opportunities offered. American Oil is particularly interested in: Chemists—analytical, electrochemical, inorganic, physical, polymer, organic, and agricultural; Engineers—chemical, mechanical, metallurgical, and plastics; Masters in Business Administration with an engineering (preferably chemical) or science background; Mathematicians; Physicists.

For further information about a challenging career for you in the Research and Development Department of American Oil Company, write to: D. G. Schroeter, American Oil Company, P. O. Box 431, Whiting, Indiana.

---

IN ADDITION TO FAR-REACHING PROGRAMS INVOLVING FUELS LUBRICANTS AND PETROCHEMICALS, AMERICAN OIL AND ITS AFFILIATE, AMOCO CHEMICALS, ARE ENGAGED IN SUCH DIVERSIFIED RESEARCH AND DEVELOPMENT PROJECTS AS:

New and unusual polymers and plastics • Organic ions under electron impact • Radiation-induced reactions • Physicochemical nature of catalysts • Fuel cells • Novel separations by gas chromatography • Application of computers to complex technical problems • Synthesis and potential applications for aromatic acids • Combustion phenomena • Solid propellants for use with missiles • Design and economics: new uses for present products, new products, new processes • Corrosion mechanisms • Development of new types of surface coatings.



**STANDARD OIL DIVISION  
AMERICAN OIL COMPANY**

# REQUIREMENTS CHANGE IN ENGINEERING

by Edward C. Wahl, GE '63

*Are high school students prepared for a college engineering curriculum? If not, how can this deficit be met? Here is a factual study of the present conditions, requirements, and alternatives facing the high schools and engineering colleges.*

Beginning in the fall semester of 1963, all new freshmen who wish to enroll in the College of Engineering at the University of Illinois must be prepared to meet a new, higher standard. The decision to change the entrance requirements was not made casually, nor were the actual changes made arbitrarily.

"In 1959, two forms of pressure were being applied to the College of Engineering, causing it to re-examine its entrance requirements—a strong recommendation by the Engineering Council for Professional Development to change the curriculum and the increasing quantity of scientific knowledge that had to be taught," says Assistant Dean David R. Opperman.

The Engineering Council for Professional Development is a nationally known and highly respected organization. Once every five years a team of council representatives visits every engineering campus in the nation and conducts a thorough study of the engineering curriculums of each college. If the curriculum of a college is found to be satisfactory, it is accredited by the Council.

"When the accrediting team was at the University of Illinois last," says Dean Opperman, "the representatives offered several suggestions to improve our curriculum. They said they would like our graduates to have a better background in the fields of social studies and liberal arts and recommended that we change our program in such a way as to incorporate these suggestions.

"But immediately we ran into a problem because we always have an increasing quantity of scientific knowledge that should be taught. A current estimate concerning total scientific knowledge states that the quantity of scientific knowledge almost doubles every ten years. As a result, since college has traditionally been a four-year program, an ever increasing amount of scientific knowledge must be pushed down to the

high school course level to enable the college level courses to include the newer scientific material."

One of the solutions to the problem seemed to be to require all incoming freshmen to have taken a certain number of social science and liberal arts courses while still in high school. In 1959, Dean Opperman was made the chairman of a special sub-committee which was given the responsibility of considering, "... the desirability of requiring some or all of the following as entrance requirements for the College of Engineering: four units of English, four units of mathematics, two units of foreign language, one unit of chemistry, one unit of physics and one unit of U. S. History."

Figure 1 shows the present requirements for the fall of 1962 and also the new requirements for the fall of 1963. Although the new requirements represent a significant change from the old ones, they have only been brought up to a level that is equal to that of many other nationally known engineering schools. For the past several years the University of Illinois has been much more lenient in its entrance requirements than schools such as Purdue, Rice, Notre Dame, Ohio State, Illinois Institute of Technology, and California Tech. In addition, all high school graduates must take the College Entrance Examination Board tests before they are even considered for admission by many of these schools.

In conducting its study of the proposed changes, the subcommittee decided that it would study the changing trends in the overall credits presented by high school classes over a four year period. The classes that were selected for study were the high school classes that entered the University in the fall of 1954 and the fall of 1958. Data for these studies came from the Office of Admissions and Records of the University.

The data was taken from the high

school transcript of each student and punched onto an IBM card to facilitate its handling. There were 694 freshmen in 1954 and 872 in 1958 that entered the College of Engineering. Also, in the case of the class of 1958, a survey was made of each of the high schools in the state of Illinois and also of a few selected out-of-state high schools to determine what percentage of the high schools offer their students sufficient courses of study to enable them to meet the proposed entrance requirements.

Figure 3 represents the results of a comparison of the classes of 1954 and 1958 with respect to the presentation of required and recommended subjects.

Examination of Figure 3 reveals an increasing trend in percentage of high school graduates presenting recommended subjects over the four year period in almost every category. The only decreasing trend over the four year period was in the category of social studies. Although only three units of English are required to satisfy the University's admission requirements, more than four out of every five new freshmen presented the recommended four units of English. Also, almost all new freshmen presented two units of any science.

From the survey of the course offerings of the various high schools in the state of Illinois at the end of the 1958 academic year, the sub-committee noticed that in all of the specific academic subjects studied that almost all of the students entering the College of Engineering in the fall of 1958 could have presented the courses required for admission.

Figure 2 shows the capabilities of the Illinois and certain out-of-state high schools for preparing their students in the specific academic subjects studied by the sub-committee.

A strict examination of the data in Figure 2 leads to the conclusion that the preparation of students in high school trigonometry is the most limited,



although this is not a critical factor with respect to admission. It is the policy of the College of Engineering to require any student who has not had high school trigonometry to take the course during his first semester in college. At the present time, a high school student who enters the University with two units of a foreign language is recognized by the College as having taken the language as an academic elective. Although the number of students who present foreign language is relatively low, the examination of the course offerings of the high schools from which the students came reveals that only ten of the students who entered in the fall of 1958 could not have presented the proposed two units of foreign language.

In the case of physics and chemistry, a detailed study of the data showed that only one student out of the 872 who entered in the fall of 1958 could not have presented either physics or chemistry. The sub-committee felt that virtually all prospective students could be expected to provide the required courses in physics and chemistry, were they to be specified as such, and that such a requirement would not be unduly restrictive.

Attraction of the students who are in the higher percentile groups of their graduating class is one of the main objectives of the University. With this objective in mind, the sub-committee studied the classes of 1954 and 1958 according to percentile groupings to determine if a trend exists among the high school students in the higher percentile groups to take certain academic subjects over others. Figure 4 shows the results of this study.

The data in Figure 4 indicates clearly that there is no distinct trend among high school students who are in the upper percentile groups in their class toward taking a particular sequence of

Subject	Required Units		Recommended Units	
	1962	1963	1962	1963
English	3	3	1	1
Algebra	2	2		
Plane Geometry	1	1		
Trigonometry	1 $\frac{1}{2}$	1 $\frac{1}{2}$		
Solid Geometry			$\frac{1}{2}$	
Advanced Math			X	X
Science		2	2	1
Social Studies		2	2	1
Language		2	2	
Additional Language				X
Totals	6 $\frac{1}{2}$	12 $\frac{1}{2}$	7 $\frac{1}{2}$ plus Advanced Math	3 $\frac{1}{2}$ plus Additional Language and Advanced Math

Figure 1: Table showing the present 1962 entrance requirements and the new entrance requirements for the fall of 1963.

subjects. A trend, if it can be called a trend, seems to exist in the lower 20 per cent group, however, where the students in this group give more emphasis to social studies than to science or foreign language.

Considering the overall value of the data presented in Figures 2, 3, and 4, it is apparent that the class of 1958 was superior in high school academic subjects to the class of 1954. The class of 1958 had better preparation in both science and foreign language than the class of 1954, and it was almost as well prepared in the field of social studies. Looking at the value of the data in terms of the proposed changes in the entrance requirements, over 45 per cent of the class of 1958 met the new proposals.

One of the reasons why succeeding high school graduating classes have had better preparation than ever before is that for the past several years high schools all over the country have been introducing formerly exclusive college

courses for their superior students. Some of the college courses that are now being taught in high schools are college algebra, analytic geometry, and differential and integral calculus. The advanced or accelerated high school mathematics and science courses usually use standard college textbooks as the source of course material.

High school educators and administrators all over the country believe that the teaching of college courses on the high school level is a necessity if their students are to be in a position to compete with the students of those high schools that already teach such advanced courses. A direct result of such programs is that many high school graduates receive advanced placement in mathematics and science when they enter college, and such advanced placement frees a certain amount of college instruction time which the student may elect to fill with some courses in the newer scientific fields—in many cases the same fields that pushed the college courses down into his high school.

One such administrator who believes in the value of accelerated high school instruction is Dean Carl Nelson of Champaign Senior High School. In the case of Champaign Senior High, Dean Nelson points out that under a new academic program initiated in the fall of 1961, a student may earn six units of high school credit in a year instead of the usual five. The system allows the courses to be taught in four 70-minute periods each week rather than in five 55-minute periods. Study halls are "virtually eliminated under this system and they are effectively replaced with a 20-minute session of supervised study at the end of each period."

If one were to look at the obvious implications of the new system as described by Dean Nelson, it is apparent

(Continued on Page 40)

	Trigonometry	Physics	Chemistry	Language (2 units)
Students Presenting (Fig. 2)	758	802	765	482
Students Not Presenting	114	70	107	390
H.S. Course Offerings				
Unknown	27	20	26	24
H.S. Course Offerings				
Known	87	50	81	366
Students Not Presenting, But From High Schools With Course Offerings	59	47	72	356
Per Cent of Students				
Capable of Presenting	96.7%	99.6%	98.9%	98.8%
Actually Presenting	86.9%	92.0%	87.7%	55.2%

Figure 2: A study of the preparation of the students entering in the fall of 1958 with respect to specific academic subjects. (Data courtesy of the College of Engineering.)

<i>Students Presenting at Least</i>	Fall 1954 Class Size 694		Fall 1958 Class Size 872	
	<i>Number</i>	<i>Per Cent</i>	<i>Number</i>	<i>Per Cent</i>
Three units of English	689	99.3%	868	99.5%
Four units of English	506	72.9%	716	82.1%
Two units of Algebra	467	67.3%	752	86.2%
One semester ( $\frac{1}{2}$ unit) of Trigonometry	520	74.9%	758	86.9%
One semester ( $\frac{1}{2}$ unit) of Solid Geometry	526	75.8%	680	77.9%
One unit of Physics	576	83.0%	802	92.0%
One unit of Chemistry	521	75.1%	765	87.7%
Both one unit of Physics and one unit of Chemistry	463	66.7%	720	82.6%
Two units of any science	640	92.2%	855	98.0%
Two units of language	346	49.9%	482	55.2%
Two units of social studies	582	83.7%	703	80.6%
Two units of language and two units of social studies and two units of any science	270	39.0%	400	45.8%

Figure 3: Comparison of students entering in fall of 1954 and fall of 1958 with regard to presentation of recommended subjects. (Data courtesy of the College of Engineering.)

<i>II. S. Ranked Groups</i>				<i>Per Cent of Group Presenting Credit of at Least:</i>				
<i>Per- centile</i>	<i>Year</i>	<i>No. of Students</i>	<i>% of Class</i>	<i>2 units any Science</i>	<i>1 unit of Physics and 1 unit of Chem.</i>	<i>2 units Language</i>	<i>2 units Soc. Stud.</i>	<i>2 units in each: any Sci. Soc. St. Language</i>
90-99	1954	136	21.5%	94	75	55	77	43
	1958	256	30.1%	99	88	62	80	50
80-89	1954	122	19.3%	95	77	52	79	40
	1958	170	20.1%	99	82	53	81	45
70-79	1954	103	16.2%	97	73	51	84	43
	1958	128	15.1%	97	80	48	72	36
60-69	1954	75	11.9%	87	65	53	89	40
	1958	108	12.7%	96	86	53	80	45
50-59	1954	74	11.8%	85	53	45	91	38
	1958	75	8.8%	97	79	59	91	53
40-49	1954	52	8.2%	96	67	42	83	35
	1958	50	5.9%	98	84	48	76	38
30-39	1954	38	6.0%	87	47	55	84	37
	1958	32	3.8%	100	79	47	92	44
20-29	1954	15	2.4%	100	80	53	80	33
	1958	13	1.5%	100	54	47	91	44
10-19	1954	11	1.7%	73	45	36	91	27
	1958	11	1.3%	100	55	55	91	45
0- 9	1954	7	1.0%	71	29	29	100	14
	1958	6	0.7%	83	33	33	100	16
No. of Students Ranked	1954	633	100.0%					
	1958	849	100.0%					

Figure 4: Per cent high school ranked groups presenting credit in specified subjects—freshmen entering in fall of 1954 and fall of 1958.\* (Data courtesy of the College of Engineering.)

\*Does not include 61 students in 1954 and 23 students in 1958 for whom rank was not known.

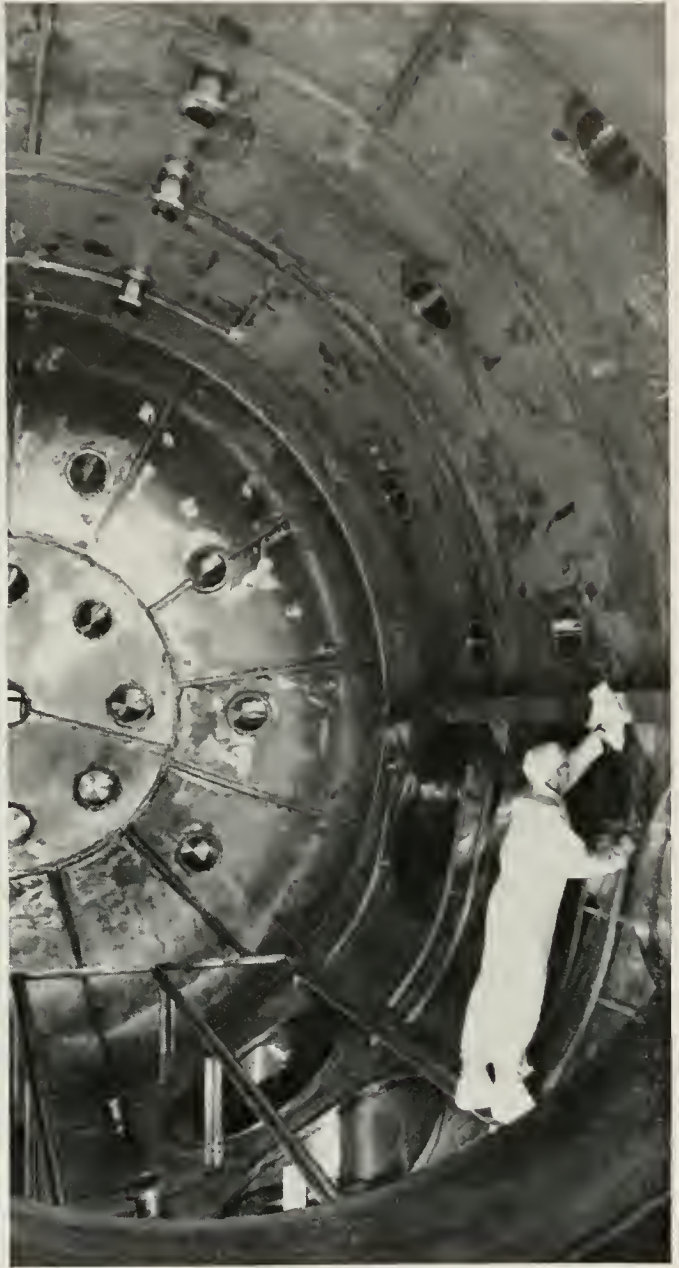

## FROM THE OCEAN'S DEPTHS... TO OUTER SPACE

Striking examples of Bendix research facilities are the huge sonar tank in California and the space chamber in Michigan, among the most completely equipped in the free world. These facilities, designed and financed by Bendix, characterize our continuing advanced product research and development efforts.

College graduates will find a variety of technical challenges. Bendix participates in almost every phase of the space, missile, aviation, electronics, automotive, oceanics and automation fields. We employ top-notch engineers, physicists, and mathematicians at all degree levels.

Bendix operates 32 divisions and subsidiaries in the United States, and 12 subsidiaries and affiliates in Canada and overseas. Our 1950 sales volume was \$210 million. Last year it was over \$750 million.

Look over the materials we have in your school's placement office. Talk to our representative when he's on campus. Meanwhile, if you'd like to have your own copy of our booklet "Build Your Career to Suit Your Talents," write to Dr. A. C. Canfield, Director of University and Scientific Relations, The Bendix Corporation, Fisher Building, Detroit 2, Michigan. An equal opportunity employer.

THERE ARE BENDIX DIVISIONS IN: CALIFORNIA, MISSOURI, IOWA, OHIO, INDIANA, MICHIGAN, PENNSYLVANIA, NEW YORK, NEW JERSEY, MARYLAND.

**WHERE IDEAS  
UNLOCK  
THE FUTURE**



FISHER BUILDING, DETROIT 2, MICH.



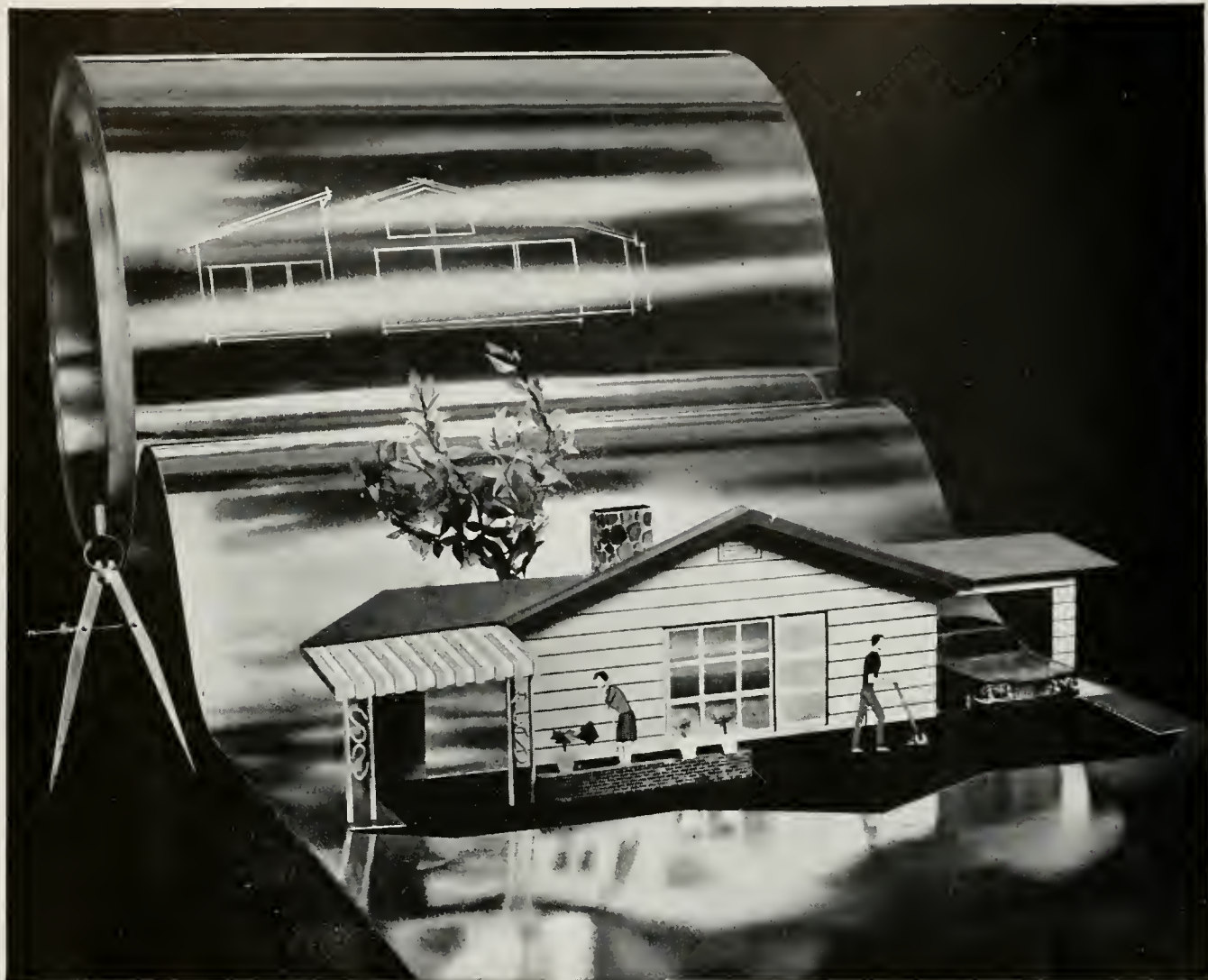

## The Promising Shape of Aluminum's Future

... an important chapter in National's growth

Aluminum is the nation's fastest growing metal. From 1950 through 1961, primary production has grown from 719,000 to 1,904,000 tons and shipments of aluminum mill products have increased from 857,000 to 1,672,000 tons. To help meet America's aluminum needs, Bridgeport Brass Company, National's metals division, is expanding its aluminum facilities and has become a fast growing supplier to industrial and home products markets.

Bridgeport entered the aluminum field in 1954 and today operates two modern plants with extensive facilities. The division makes aluminum sheet, rod and forgings as well as defense products and components for aluminum awnings, blinds and siding at a plant at Riverside, California. The Warren, Ohio plant produces aluminum coiled and flat sheet. Capacity in both locations was increased in 1961. This year, Bridgeport will be one step closer to aluminum integration upon completion of a new hot rolling mill at Oswego, New York—a joint venture with three other companies.

These facilities, added to almost 100 years experience in metals, enable Bridgeport to provide aluminum going into products as varied as appliances and cars, electrical parts and machinery. For the country's defense, the division turns out weapons such as the "Sidewinder" and "Zuni" missiles. And in building products, one of the fastest growing aluminum fields, Bridgeport markets Flexalum<sup>®</sup> Awnings and Blinds, and recently introduced a major new product, Flexalum Siding.

Aluminum is the important "A" in Bridgeport's "A" to "Z" line ranging through brass and copper and stainless steel to such space-age metals as titanium, uranium and zirconium.

*A Career at National* . . . National is moving ahead in chemicals, plastics and metals, producing materials for defense and growing peace-time markets. Chemists, engineers and metallurgists seeking an unlimited future are invited to contact our Professional Employment Mgr., 99 Park Ave., N. Y. C.

## NATIONAL DISTILLERS and CHEMICAL CORPORATION

*Divisions:* NATIONAL DISTILLERS PRODUCTS CO.  
BRIDGEPORT BRASS CO.

*The Company with the Five Industry Future*  
Liquors • Chemicals • Plastics • Fertilizers • Metals

U. S. INDUSTRIAL CHEMICALS CO.  
FEDERAL CHEMICAL CO.



## Small car economy with big car performance

Breakaway acceleration from 0 to 60 mph in just a fraction over 8 seconds. That is the unheard of big car performance achieved with small car economy by a popular 1962 automobile turbocharged by Garrett-AiResearch.

The Garrett turbocharger is the first controlled for optimum performance at all driving speeds. No matter how fast or slow you may be traveling, sudden acceleration and extra pulling power are there instantly and smoothly when you need them — on any grade at *any* altitude.

How is it possible? The Garrett turbocharger, driven entirely by the engine's waste exhaust gases, sucks in larger

amounts of outside air and forces maximum fuel-air charges into the cylinders. This means better combustion, more power.

Other areas of concentration at Garrett include: space life support systems, solar and nuclear power systems, electronic systems, air conditioning and pressurization systems, computer systems and small gas turbines for both military and industrial uses.

For further information about a career with The Garrett Corporation, write to Mr. G. D. Bradley in Los Angeles. Garrett is an equal opportunity employer.



THE GARRETT CORPORATION • AiResearch Manufacturing Divisions • Los Angeles 9, California • Phoenix, Arizona • other divisions and subsidiaries: Airsupply-Aero Engineering • AiResearch Aviation Service • Garrett Supply • Air Cruisers • AiResearch Industrial • Garrett Manufacturing Limited • Garrett International S. A. • Garrett (Japan) Limited



## Safer Driving Through Mathematics

Perhaps you don't know how fast or slow you'll drive the next time you go on a trip — but we do, at least with a high probability. The speed motorists assume is an important question to the traffic engineer, and also a complex one; the answer depends not only on external factors such as traffic, road conditions, etc., but is further complicated by the behavior of the driver. Thus the theory of traffic flow depends on the application of knowledge from both the physical and the behavioral sciences. A recent study in the University of Illinois Department of Civil Engineering offers some answers.

This investigation, conducted by Dr. J. C. Oppenlander of the Traffic Engineering Section, involved the development of a mathematical method for predicting vehicle speeds on existing or proposed streets and highways. Forty-nine variables that represent travel conditions were measured in a series of observations of traffic on two-lane Illinois highways.

Factor analysis performed on a digital computer indicated that 68 per cent of speed variations are accounted for by five external factors; horizontal resistance (curves, no-passing zones, etc.); long-distance travel (driver residence, type of vehicle, etc.); marginal friction (roadside development, intersecting traffic, etc.); vertical resistance (grades, sight distance, etc.); and obsolete pavement (lane width, lack of pavement markings, etc.).

The results of this work permitted the determination of a more practical equation in terms of out-of-state cars, combination trucks, degree of curve, gradient, minimum sight distance, lane width, number of roadside establishments, and total traffic volume. This expression explained approximately 62 per cent of the variation in observed speeds.

While external factors account for a large percentage of speed variations, an additional 23 per cent may be attributed to the driving inconsistencies of the individual motorist. Coupling this data with the external factors offers a reasonably complete answer to why people select the speeds at which they drive. Such information helps the traffic engineer to evaluate the desirability of proposed highway improvements, to calculate the traffic conditions of planned highway facilities, and to establish reasonable speed regulations for different localities. The mathematical method has real value because it gives the traffic engineer a new tool to accomplish his purpose, which is to help man get from where he is to where he wants to be—comfortably, quickly, and safely. ◆◆◆

—*Engineering Outlook*

# NEWS

and

AT

# VIEWS

## The Final Step

Research has no value until it is communicated. The University of Illinois College of Engineering has communicated research results through its Bulletin series for more than 50 years. This has resulted in a world-wide net of communications with other researchers and with people in industry, but the system has not always allowed the quick dissemination of interim research results of immediate value to other engineers. A new series to give greater flexibility and shorter lead times will soon be started by the Engineering Publications Office. The series will be called Technical Reports.

The Technical Report series will present research results from the College of Engineering, just as the Bulletin series now does. The Bulletin series will be reserved for monographic treatments of final results from major research efforts. For example, some bulletins in the past have presented results, summaries, and evaluations of research programs extending over ten or more years. The Technical Report series, on the other hand, will carry material such as interim results of phases of larger research efforts, and other research results not of sufficient scope and length to justify bulletin treatment. By adding this new series the Engineering Publications Office will have a broader, better balanced program for publishing research results from all departments of the College of Engineering.

Editorial and review standards will remain the same as for bulletins, but printing will be done by offset printing methods. The advantages of this approach will be lower costs and shorter production times. In rapidly developing research fields, time can be extremely important in making research results available to other engineers.

The first in this new series will be published late this spring, according to present plans. Publications in this series will be announced in *Engineering Outlook* as they become available. ◆◆◆

—*Engineering Outlook*

## Facility for Basic Research On Materials

Someday engineers will be able to decide what material they need for a job and have it made to order. This ability to make special materials for specific jobs is one of the goals of today's materials research. Such research at the University of Illinois will receive a big boost with the completion of the recently announced Materials Research Laboratory.

Funds for constructing and equipping the five-million dollar building will be provided by two federal agencies, the Advanced Research Projects Agency of the Department of Defense and the Atomic Energy Commission, and by the University of Illinois. The Laboratory will conduct interdisciplinary research in the materials sciences under the direction of a steering committee representing the five departments participating in the establishment of the Laboratory: Ceramic Engineering; Chemistry and Chemical Engineering; Electrical Engineering; Mining, Metallurgy, and Petroleum Engineering; and Physics. This steering committee is under the chairmanship of Dr. F. Seitz, Head of the University of Illinois Physics Department.

According to R. J. Martin, Director of the Engineering Experiment Station, the new Laboratory will approximately double the University's capability for research on basic properties of materials and its capacity to provide graduate education to scientists and engineers in this area of study. "It is certainly a recognition," he said, "of the University's past achievements in materials research, and it will help overcome the lack of laboratory space available for this work that we have encountered in the last several years. The five departments that will be involved have distinguished themselves in materials research, and this new facility will enable them to work together on problems in a way that is impossible at present." ◆◆◆

—*Engineering Outlook*

# UNIVERSITY

THE

of

# ILLINOIS

## New Accelerator Proposed

Midwestern Universities Research Association (MURA), of which the U. of I. is a member, has announced it has submitted a proposal to the Atomic Energy Commission for a new 10 BEV high intensity particle accelerator. These accelerators are designed to increase the energy of atomic particles and cause them to disintegrate through collisions with other particles in a target. Careful study of these smaller particles enables the scientist to further understand the basic parts of the atom, its construction, and its ability to stay intact.

Similar studies 30 years ago resulted in the recent development of atomic power plants which are used to power submarines, ships, and electric generators. Scientists and engineers are utilizing the results of more recent studies to improve the processing and sterilization of food and medicine.

The proposed accelerator utilizes a new principle known as Fixed Field Alternating Gradient (FFAG) focusing. FFAG uses a series of direct current magnets to guide the particles in their circular path around a vacuum tank in the accelerator. As the particles' speed of rotation increases, it is necessary to increase the strength of the force (magnetic field) which keeps them on the track. This is the "alternating gradient" aspect of FFAG. Most other accelerators use a pulsed magnet to attain these guide forces.

The proposed accelerator will have a beam of protons calculated to be 2,000 times greater than that obtained by the new BEV accelerators at Brookhaven National Laboratory on Long Island, and at CERN, Switzerland, which are two of the world's largest accelerators currently in use. A beam of this intensity (which is a measure of the number of particles being accelerated) will allow the scientists to produce and study more events (collisions of particles with a target or with each other) than is possible with existing machines. This has the ef-

fect of reducing the time necessary to carry out a specific research task because the scientist can study and analyze more events in less time than was previously possible.

The new accelerator proposal represents the result of six years of research carried out by the staff of MURA. During this time, three smaller accelerators were constructed to prove the feasibility of certain new principles and techniques. This work has received primary support from the Atomic Energy Commission, with additional support from the National Science Foundation and the Office of Naval Research.

MURA consists of 15 Midwestern universities, representing nine states, organized to carry out research. The primary purpose for the foundation of MURA was to institute a program which would provide high energy physics research facilities in the Midwest. This was necessary to retain high caliber physicists in the Midwestern universities. MURA's Member Universities are Iowa, Iowa State, Ohio State, Minnesota, *Illinois*, Indiana, Notre Dame, Purdue, Washington, Michigan State, Michigan, Northwestern, Kansas, Wisconsin, and the University of Chicago.

## U. of I. Second in Engineering Doctorate Degrees

During the last ten years the University of Illinois has more than doubled the number of doctorate degrees granted in engineering to rank second in the nation, according to data collected as preliminary to a study by Prof. Ralph Morgen, Dean of Graduate Studies, Stevens Institute of Technology.

Comparing the latest nationwide figures of 1960-61, and of 1950-51, Prof. Morgen found that Illinois increased doctorates in engineering from 30 to 79. During the same period Massachusetts Institute of Technology, first in doctorates, increased from 83 to 97, while Michigan was third with 43 and Purdue was fourth with 41. ♦♦♦

## Prof. Johnstone Honored for Air Pollution Research

For leadership in research on air pollution, Prof. H. Fraser Johnstone, University of Illinois chemical engineer who died early in January, was honored at a three-day Memorial Symposium in Atlantic City, N. J. Forty papers on smog, fumes, fog prevention, and closely related topics were presented during the September 12-14 symposium.

Prof. Johnstone came to Illinois in 1928 and for many years headed the division of chemical engineering. His last research was reported in the symposium by Kay Kingsley of Ottawa, Canada, who worked with the Illinois scientist.

Through some 35 years, Prof. Johnstone was one of the leading authorities in this work. He made field and laboratory studies of air pollution sources, effects, and prevention, and was called on for many national conferences and projects. For many years he was the scientific advisor in Los Angeles County, California.

In 1951 he became chairman of the new American Chemical Society committee on air pollution, which included members from industry, universities, and research institutes. He was known also for his work on aerosols and fumes, and for wartime development of devices for dispersing smoke, gases, and insecticides.  
—*Engineering Outlook*

## Prof. Bardeen Receives Award

Prof. John Bardeen, University of Illinois physicist who in 1956 received the Nobel Prize as co-inventor of the transistor, accepted on Sept. 15, the 3rd Frietz London Award for distinguished research in low-temperature physics. Presentation was at the 8th International Conference on Low Temperature Physics, meeting at the University of London.

Prof. Bardeen was honored for development of the first successful microscopic theory of superconductivity, which is the loss of all electrical resistance by some metals at extremely low temperatures. The Bardeen-Cooper-Schrieffer theory of superconductivity, published in 1957, has played an outstanding role in clarifying one of the principal problems in solid state physics.

The award, established in 1957, is presented every two years. It honors Fritz London, first scientist to clarify the nature of superconductivity. ♦♦♦  
—*Engineering Outlook*



# *Cute Kappa*

*from*

# *Columbus*

Marjorie Watson



To start off this year's feature with a bang, TECHNOGRAPH takes pleasure in featuring 5 feet, 4 inches of stunning loveliness: Miss Marjorie Watson of Columbus, Ohio, who is currently residing at Kappa Kappa Gamma sorority. Marjorie is a true outdoor girl, and has just returned from an exciting summer at Camp Sequoya, Virginia, where she had plenty of opportunity for swimming, water skiing, tennis, golf, and hiking.

As you can see by these pictures, Marjorie is quite a knockout, a shapely bundle of well-packaged pulchritude. Incidentally, she has quite an independent and extroverted personality. And—she even likes engineers.



## Learning never stops for engineers at Western Electric

There's no place at Western Electric for engineers who feel that college diplomas signify the end of their education. However, if a man can meet our quality standards and feels that he is really just beginning to learn... and if he is ready to launch his career where learning is an important part of the job and where graduate-level training on and off the job is encouraged — we want and need him.

At Western Electric, in addition to the normal learning-while-doing, engineers are encouraged to move ahead in their fields by several types of educational programs. Western maintains its own full-time graduate engineering training program, seven formal management courses, and a tuition refund plan for out-of-hours college study.

This learning atmosphere is just one reason why a career at Western Electric is so stimulating. Of equal importance, however, is the nature of the work we do. Our new engineers are taking part in projects that implement the whole art of modern telephony from high-speed sound transmission and solar cells, to electronic telephone offices and computer-controlled production techniques.

Should you join us now, you will be coming to Western Electric at one of the best times in the company's history.

In the management area alone, several thousand supervisory jobs are expected to open up to W.E. people within the next 10 years. And our work of building communications equipment and systems becomes increasingly challenging and important as the communications needs of our nation and the world continue to increase.

Challenging opportunities exist now at Western Electric for electrical, mechanical, industrial, and chemical engineers, as well as physical science, liberal arts, and business majors. All qualified applicants will receive careful consideration for employment without regard to race, creed, color or national origin. For more information about Western Electric, write College Relations, Western Electric Company, Room 6205, 222 Broadway, New York 38, New York. And be sure to arrange for a Western Electric interview when our college representatives visit your campus.



Principal manufacturing locations at Chicago, Ill.; Kearny, N. J.; Baltimore, Md.; Indianapolis, Ind.; Allentown and Laureldale, Pa.; Winston-Salem, N. C.; Buffalo, N. Y.; North Andover, Mass.; Omaha, Neb.; Kansas City, Mo.; Columbus, Ohio; Oklahoma City, Okla. Engineering Research Center, Princeton, N. J. Teletype Corporation, Skokie, Ill., and Little Rock, Ark. Also Western Electric distribution centers in 33 cities and installation headquarters in 16 cities. General headquarters: 195 Broadway, New York 7, N. Y.

# ENGINEERS & PHYSICISTS

Campus interviews at University of Illinois will be conducted on November 15, to select qualified engineers and physicists to take part in the development of Stanford University's new two-mile linear electron accelerator.

The accelerator, being built under a \$114,000,000 contract with the Atomic Energy Commission, is designed to produce an electron beam of 10-20 Bev (billion electron volts), which can be increased to 40 Bev should it later prove desirable. Planned for completion in six years, the Stanford Linear Accelerator Center will then take its place among the principal international centers of particle physics research.

The Center presents an outstanding opportunity to work in highly stimulating intellectual atmosphere. It is situated on the 9,000 acre Stanford University campus on the beautiful San Francisco Peninsula. Engineers and Physicists working toward advanced degrees in the following fields are especially needed at this time: ELECTRON BEAM OPTICS KLYSTRON TUBE DEVELOPMENT MICROWAVE ENGINEERING MACHINE DESIGN.

To arrange for an interview on the above date, please contact your University (or Engineering) Placement Office. If this is inconvenient, write Mr. G. F. Renner, Employment Manager, Stanford Linear Accelerator Center, Stanford University, Stanford, California. An equal opportunity employer.

STANFORD LINEAR ACCELERATOR CENTER



# How to get the most out of a job interview:

Every company that interviews college students is interested in hiring students with high potential. But matching the right man with the right company is a complex assignment. How can you know which company you should join? You can't know for sure, but you can get a reasonably accurate indication if you make the most of your campus interview. Below are a few suggestions to assist you in making such an interview with Koppers more worthwhile and productive for you.

**1** Before the interview, stop in your Placement Office and review in some detail the literature explaining Koppers diversified line of products and services. Become familiar with Koppers eight operating divisions and the particular contribution each makes to industry.

**2** Try to determine as specifically as you can the type of work that seems to interest you most. Then question the interviewer as to how that type of work fits into Koppers many activities. If, like many graduates, you find that your interests cover many areas of work, tell the interviewer. You'll find that he will understand your problem

and may be of help in deciding on the kind of "Koppers opportunity" for which you would be best suited.

**3** Be prepared to outline your accomplishments. He will be interested in your extra-curricular activities as well as your scholastic achievement. Point out any part-time or summer experience which you may have had. If you can effectively communicate to the interviewer your background and interests, both you and he will be better able to decide whether or not this is the right opportunity for you.

**4** Review with the interviewer Koppers on-the-job training program. This program is designed

to allow you to make an immediate and recognizable contribution. You go to work—you don't return to the classroom for training. You will be working on projects that will permit you to apply the knowledge you have gained through your college training, while at the same time you will be furthering your knowledge and understanding of your field.

**5** Ask the interviewer about job location, military policy, educational assistance policy, and any other questions which you may have about the Company. He will be happy to provide any information he can to assist you in getting the most from your Koppers interview.

*If the possibility of a career with Koppers interests you, contact your Placement Office and arrange to see the Koppers representative on his next visit to your campus.*

**KOPPERS**  
Pittsburgh, Pennsylvania



# To Tell The Truth

by Larry Balden, EE '64

"Four more ahead of me," Albert thought. "Just four more to step up and bravely swallow their pill and then go into a booth to spill out their silly little minds to the Memory."

Albert had always wondered what life had been like before all this. "It must have been great not having to celebrate your birthday by making a present of your mind to the Memory," he thought bitterly. "That stuff about catching spies couldn't have been the real reason for going so far. I'd like to get my hands on the guy who dreamed up the idea of connecting all the computers in the country together and the guy who discovered the Pill so I could beat their heads together."

The benefits of the Memory were well publicized, and Albert knew them as well as anyone else. Tests were used to find out when a child became capable of a genuine lie. Most children had their first interview at between four and six years, and from that time on the Memory knew their opinions, abilities, and desires. "They say it is so we will have the work best suited to us," thought Albert. "Well, my job doesn't suit me. I can't stand it any longer. I'm not going to take my pill."

The person ahead of him had just gone into an interviewing booth, and he moved up. At that moment, his last year's pill wore off; and he stood hesitating, enjoying the feeling of deceit which washed over him. He handed his identification card to the serologist, who inserted it in a slot on her console for the encoded dosage to be read, pushed the proper buttons, and gave the pill which came out to Albert. He moved calmly over to the water fountain, checking with his tongue to be sure the waterproof plastic capsule was in place. All the girl at the console saw was that when Albert tried to wash his pill down, he had trouble swallowing and started to cough violently. She tried to help by patting him on the back and was quite unaware that he had slipped the pill into the cuff of her sleeve. He thought of the weeks of solitary practice that had gone into the perfection

of the trick of concealing the pill in the container and then coughing it out into his hand. "That went well enough, but the worst is yet to come. I've got to make the Memory believe I've taken my pill. That means telling the truth for just a little while longer."

He stepped into a vacant booth, sat down, took a deep breath, and put on the headset. A pleasant voice said, "Welcome. Please insert your information-identification card in the slot in front of you, and tell me your name, age, and occupation."

Albert's hand shook so much that he missed the slot the first time. "Well, here goes," he thought as he replied, "Albert Jamison, twenty-nine, statistician, junior level."

"Are you now or have you ever been affiliated with any organization whose aim was to overthrow the government?"

"I have not." And on it went; rapid-fire questions which Albert answered truthfully because that was the quickest way. Finally, the questions he had been expecting came. "Have all your answers been the truth?"

"They have."

"Could you, if you wished, tell a lie?"

Albert tried to answer with the right amount of conviction. "No, I couldn't," he said and waited.

"That is all. You may go in peace."

Albert took his headset off with relief, thinking exultantly, "I did it! It believed me!" He stood up unsteadily; and, struggling to keep his expression and walk natural, left the booth and moved over to the verification desk for the tattoo proving he had been interviewed. He decided to use the pretty nurse in an experiment.

Glancing at her name tag, he said, "So you're Miss Forster! I was told you needed an evening out on the town. The Memory seems to think we have much in common. I'm to pick you up at some convenient time. Do you get off work at five?"

The nurse looked a bit surprised but said, "I had a tentative engagement; but if the Memory says I should go out

with you, I suppose you can call at seven. It's Building C here at the Center."

Albert smiled. "See you then," he said and left the Center. "Not a shadow of unbelief," he thought, "this is going to do wonders for my love life." As he walked home, Albert thought of all the things he could do, especially to Old Grimy. "I must be careful though. If I do anything too radical, the C.I.A. will be on me with one of their spot checks and an injection."

Albert mused all the way home over his situation. He was in the position of a man who had succeeded in stealing a million dollars only to find that all but a hundred of it was in marked bills. "At least," he thought, "I'll have some fun and, if I get nothing else, I'll get out of that lousy statistician's job."

Understandably, Albert didn't sleep well at all that night. His dreams were a confused mixture of beautiful women completely in his power, Old Grimy, and the C.I.A. He woke up with what, if not genuine, was the next best thing to a fine old hairy-tongued hangover. His needle shower and depilatory revived him somewhat; and after two cups of very strong coffee, he felt more the

He was late to work; and when he arrived, he found his boss waiting irately. "You, Mister Jamison, are late. I will tolerate an explanation, though the roadmaps on your eyeballs probably are explanation enough." His humor was in rare form.

"Good morning, Ol—, er, Mr. Grimes. As a matter of fact, Jason, I did celebrate a bit last night." Albert was enjoying himself now. "With good reason, I might add. At my interview, they told me I was to be entered in executive training school. You're supposed to tell me who to see about it."

"Is that so? Well, it just proves how amazing the Memory is. It must have found more talent in you than I've been able to. Calahan on the tenth floor is head of that. The quicker you get up there, the quicker I'll be able to start forgetting your miserable face."

# Laminated Plastics ANY WAY You Want Them



We make laminated plastic sheets in thicknesses of .005" to 8", and in a wide range of commercial and government grades. Sizes 36" x 36", 36" x 48", 36" x 72" and 24" x 96". Hitch-cured sheets in lengths up to 29 feet, and in widths up to 24" are also available. Synthane is a prime source for metal-clad laminates in all the popular grades and foil thicknesses, and new G-10R, a high hot peel strength copper-clad grade.

We make tubes in a very wide range of grades, diameters, lengths and wall thicknesses—round or irregular in section. Rods in equal variety.

We fabricate sheets, rods and tubes to your specifications in the largest shop of its kind in U.S. We make our own tools and dies.

We make molded-laminated and molded-macerated parts. What do you need in laminates?

## SYNTHANE

CORPORATION **S** OAKS, PENNA.  
GLendale 2-2211 TWX Valley Forge 735U

Synthane-Pacific 518 W. Garfield Ave., Glendale 4, Calif. TWX GLDL 4417U

Synthane Corporation, 13 River Rd., Oaks, Pa.

Gentlemen:  
Please send me your complete catalog of Synthane laminated plastics.

Name \_\_\_\_\_

Address \_\_\_\_\_

City \_\_\_\_\_ Zone \_\_\_\_\_ State \_\_\_\_\_

"I am also supposed to get the rest of the day off," Albert said, getting one last jab.

"Take the rest of the year for all I care; just get out of my sight!"

With a speed noticeable only by the near-zero elapsed time, the elevator rose to the tenth floor. As he stepped through the door, Albert thought, "Yipe! I must have skipped some floors. This looks like heaven." The beauty of the secretary behind the nearest desk only gave substance to the thought. Albert gazed around while getting his courage back, and finally waded through the thick carpet to her desk. "I'm here to see Mr. Calahan about executive training school. Mr. Grimes in Statistics said I should see him." Unable to resist, he added, "He also showed me a directive to the effect that new trainees were to escort the secretary of their choice for an evening of dinner and dancing, on your expense account of course. It is supposed to accustom us to the executive way of life, I believe."

"Oh really? I hadn't heard about this, but I suppose it will be all right. However, we can take care of the details later. Right now, Mr. Calahan is expecting you. Go right through that large door if you please, Mr. Jamison."

"Expecting me," Albert thought, horrified. "How? There wasn't time for Grimes to call. How did she know my name?" Albert nearly panicked before he reached the door. It opened by itself, and Albert walked into the most sumptuous office he had ever seen. Behind a fantastically arrayed desk sat a man Albert assumed was Mr. Calahan. In an authoritative voice, he said, "Mr. Jamison! So good to see you. Won't you sit down." Albert sat, feeling trapped. The man continued, "Now tell me, what gave you the idea to fake taking your pill yesterday?"

Albert slumped further in his chair. He said weakly, "I thought something was wrong when I came in here. You must have known all along."

"Yes, we knew from the minute you sat down in that booth, and the radioactive trace element didn't show up on the Geiger counter. Now, if you'll just follow me, we have some plans for you."

"I'll just bet you have," Albert thought helplessly. "An injection first then a speedy trial." He stepped through the door Mr. Calahan held for him into another office which seemed only a little less comfortably furnished than the first.

Mr. Calahan said, "Well, here we are. This will be your office. I've needed someone with your initiative as my assistant for sometime. Your instructions are on the tape in the desk, so you may start immediately. Good luck."

Albert was silent; probably because he had not yet thought to close his mouth. ◆◆◆



# Is lin right for you?

## That depends on the future you want.

Graduates in science, engineering and business administration will find an abundance of career opportunities at Olin. Our major areas of activity are carried on through 7 divisions: Chemicals, Metals, Organics, Packaging, Squibb, Winchester-Western, and International.

You can start in any division, but your advancement is not necessarily confined to the division you choose. (Olin is flexible.)

Olin has a substantial research budget. And our research laboratories are among the most advanced in the field. We give you the resources and equipment that creative research and development demand.

*Do you want to know some of the things Olin has done?*

We developed a process for producing any continuous tubing pattern into a homogeneous sheet of aluminum or copper. It's called Roll-Bond.<sup>®</sup> (Designers have a field day with this one.)

We make the hydrazine derivatives that power Titan rockets. And the explosive bolts that separate rocket stages.

Nydrazid,<sup>®</sup> our anti-tubercular drug, is one of the major reasons TB deaths have decreased 60% in the last eight years.

*Do you want to know some of the things we're doing?*

We're developing a high-speed cartridge that will enable medicine to be injected without the use of hypodermics.

We're coating packaging film with antibiotics to do away with the tremendous waste in food spoilage.

We're perfecting a process that will enable doctors to replace diseased bones.

These are just some of the things Olin is doing. (Our research and development average: One new product every week.)

Do you think Olin may be for you?

If you call us, we'll do our best to help you reach a decision.

**For information on your career opportunities, the man to contact is M. H. Jacoby, College Relations Officer, Olin Mathieson Chemical Corporation, 460 Park Avenue, New York 22, N. Y.**

*An equal opportunity employer.*

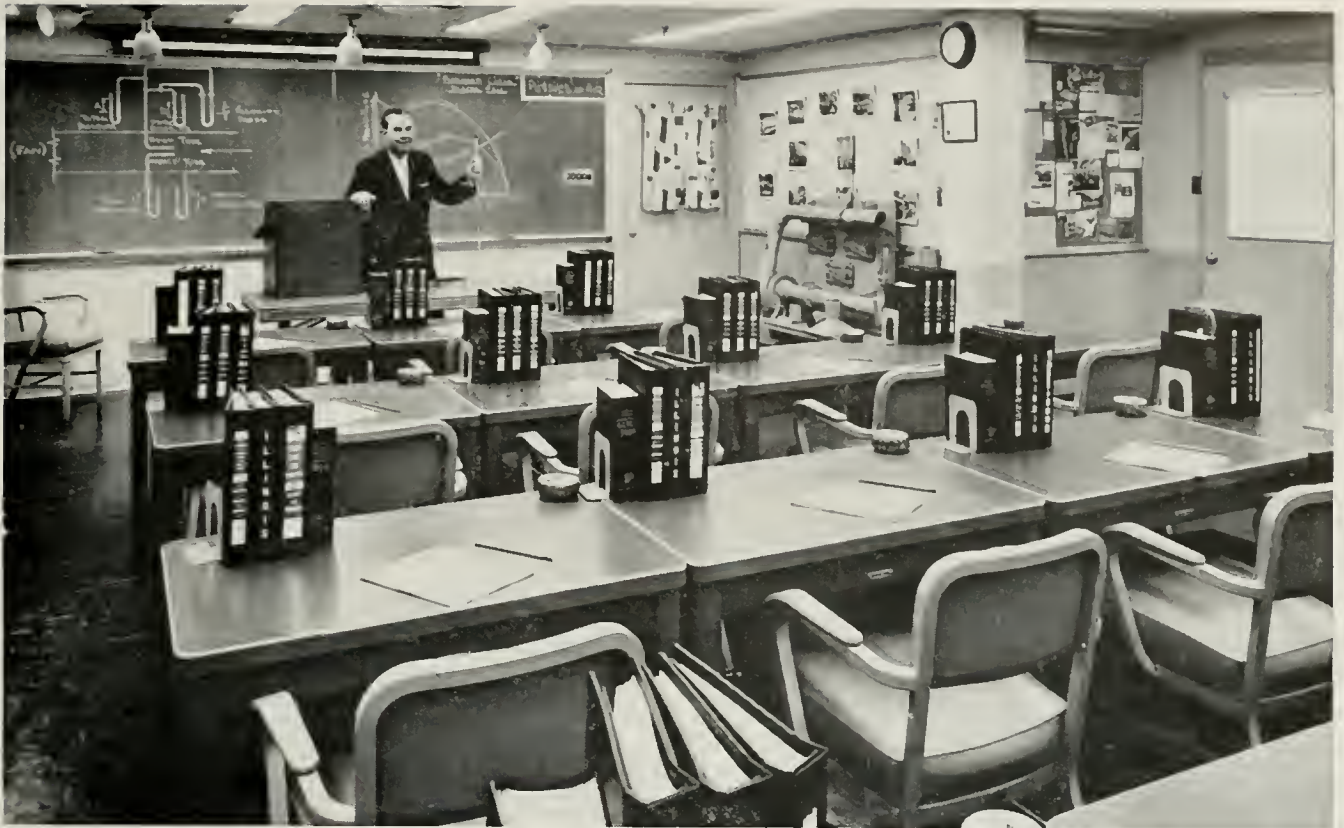

Technical training classroom of AAF. Shown here is James W. May, Technical Director of AAF Air Filter Division, also National Treasurer of ASHRAE.

## Engineers who qualify to fill these chairs...

are on the road to filling responsible jobs  
with a growing company in a growing industry

● American Air Filter Company is one of the world's pioneers in the field of "better air." Established in 1926, as a manufacturer of air filtration equipment only, it has, through a planned program of product development, attained the unique position of being the one company in its industry that can take the complete over-all approach to the customer's air problems. In brief, this means supplying and coordinating all the proper products to filter, cool, heat, clean (control process dust), move, exhaust, humidify and dehumidify air.

"Better Air", while a big business today, is still in its infancy. Name any industry, any building type, and you have a present or potential user of AAF equipment. Other well-known trade names in the AAF family are Herman Nelson and Illinois Engineering. At present, AAF operates ten plants in Louisville, Moline, Ill., Morrison, Ill., Rock Island, Ill., St. Louis, and Montreal, Canada.

**THIS KIND OF  
ENGINEERING DEGREE . . .**



Mechanical — Engineering, Sales or Manufacturing  
Electrical — Engineering or Sales  
Industrial — Manufacturing or Sales  
Civil — Sales

**. . . QUALIFIES YOU FOR  
THIS KIND OF JOB**



### TRAINING PROGRAM

AAF's method of training is to combine a formal program of instruction with other experiences so as to provide the man with the specific knowledge of the company and its products to enable him to meet the requirements for the job to which he is assigned. Training at AAF includes orientation, basic technology, product information, plant tours, and field trips as a part of the program. There is also a program of independent study available both within the company and the nearby colleges and universities to assure continuing intellectual growth after leaving college.

### YOUR FUTURE IS ALL-IMPORTANT TO AAF

AAF prides itself on attempting to match the man to the job. During your training period you will have contacts with key company personnel. Your personal desires as to type and location of job are given every consideration. AAF is big enough to provide opportunities — small enough to never lose sight of the personal touch that adds satisfaction along with success.

A representative of AAF will be on your campus soon to interview students interested in learning more about the opportunities with this company. Consult your Placement Office for exact date.



**American Air Filter**  
BETTER AIR IS OUR BUSINESS





*Architecturally Speaking,  
Here IS the Aggressive "New South"*



*Only the very best  
(including JENKINS VALVES)  
would do for  
SIRRINE'S own new office building*

*Architects and Engineers: J. E. Surrine Co.  
General Contractor: Yeargin Construction Co.  
Air Conditioning Contractor:  
Sanitary Plumbing & Heating, Inc.  
Plumbing Contractor: E. R. Kellett & Co.  
All Greenville, S. C.*

In the big, bustling Southeast, J. E. Surrine Company is a big name. Architects and engineers, they have planned and designed many of the area's new industrial and commercial buildings, with special emphasis on plants for the fast-growing textile and pulp-and-paper industries.

Surrine's own new office building in Greenville, S. C. is both symbol and showcase: a model of functional efficiency, and standing proof that a commercial edifice *can* be architecturally attractive as well. Naturally, only the finest of materials and equipment went into this building.

*Including (naturally) Jenkins Valves*—used throughout, for all heating, plumbing and air conditioning lines. After all, Jenkins has been the accepted "Standard of Quality" for almost a century. Architects, contractors, engineers and operating men—by the thousands and thousands—all know from experience that Jenkins Valves save valuable "down time" and cut maintenance costs. They're cheaper in the long run.

Yet Jenkins quality *costs no more* than other quality valves. Give it a thought, won't you? They cost no more—yet they'll save *you* time and money year after year. Jenkins Bros., 100 Park Avenue, New York 17, New York.

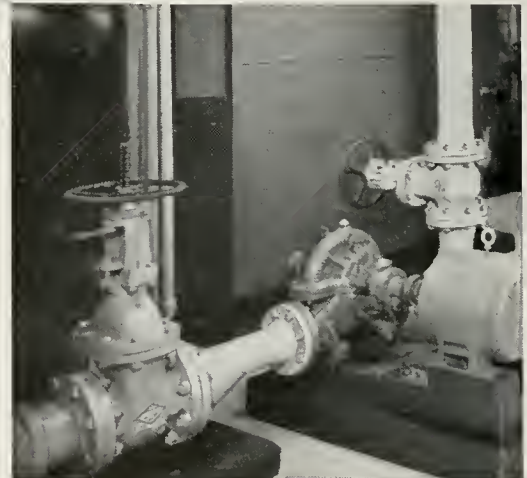

**JENKINS**

MOST TRUSTED TRADEMARK IN THE VALVE WORLD

**VALVES**



*Available From Leading Distributors Everywhere*





## The moment of insight is a private thing.

It can happen anytime, anywhere. Somewhere in the mind the barrier to a solution crumbles. Everything suddenly slips into place. It can't be forced or commanded. But it comes about most often in a climate of mutual respect and recognition. This is the kind of climate you'll find at Northrop.

You'll also work in a climate of constant professional challenge at Northrop. We have more than 70 active projects in work, and we're always evaluating new lines of inquiry. Present programs cover such fields as interplanetary navigation and astro-inertial guidance, aerospace deceleration and landing, man-machine and life support systems for space, automatic checkout and failure prediction systems, laminar flow control techniques and world-wide communications.

For more specific information, see your placement counselor. Or write to Dr. Alexander Weir, Northrop Corporation, Beverly Hills, Calif., and mention your area of special interest.

**NORTHROP**  
AN EQUAL OPPORTUNITY EMPLOYER

# Educators Confer on Mechanical Technology

by Larry Druffel, EE '62

Prominent educators from the State of Illinois traveled to Champaign-Urbana October fourth and fifth to meet with members of the U. of I. Engineering Staff. These educators gathered at the Motel Urbana to attend the first Conference on Mechanical Technology in the United States.

The purposes of the conference, as stated in the program, were: a) "to develop an understanding of educational needs in the field of Mechanical Technology;" b) "To promote two year post-high school Mechanical Technology programs;" and c) "To identify curriculum needs and laboratory requirements for an adequate Mechanical Technology program."

## Need for Trained Mechanical Technicians

With the increased rate of technical developments, the engineer's task has become more complex. Time has become all important to the project engineer who is plagued with a lack of engineering support talent. Engineers simply cannot devote time to many of the functions once considered their responsibility. More than anything else, engineers need support from the technicians who work with them. Technicians must be trained to relieve some of the burden from the engineer's shoulders. From where will these technicians come?

The best way to get trained technicians is to train them formally. Some schools have initiated programs designed to produce qualified technicians, but the problem of what to teach is a haunting one.

## Mechanical Technician Curriculum

The problem of what to teach technicians was the topic of the conference. All were agreed that the courses must be taught with college rigor, although all courses will not be applicable towards a baccalaureate in engineering.

Science and mathematics head the list of necessary courses. Courses in these fields should include algebra, trigonometry, applied analytical geometry, calculus, mechanics, heat, electricity, and the chemistry of engineering materials. These will lay the foundation for a technician's understanding of engineering problems.

With the scientific and mathematical groundwork carefully provided, specialized technology will follow. Coursework will include: statics, dynamics, strength of materials, manufacturing processes, mechanisms and design of machine elements, electric and hydrolic controls, and machine design projects. These courses will acquaint the technician with engineering problems. They will provide a background sufficient for intelligent discussions with engineers and an understanding of their language.

To enhance the use of this background and aid the technician in communicating with engineers, courses in verbal and graphic communication will be offered. These courses will include: rhetoric, composition, technical report writing, sketching, theory of projections, descriptive geometry, dimensioning tolerance, sections, assemblies, charts, and graphs. With this background, the technician will be equipped to speak the engineer's language as well as understand his world of drawings, sketches, and numbers. With it, he can formulate his ideas and submit useful reports.

Sociological studies will include: American Institutions (sociological, economic, and governmental), psychology, and human relations, economics of in-



Professor Dobrovolny and Walter Bartz conferring over detailed administrative problems.

dustry, and industrial organization and operation. These courses will aid the technician in his contact with fellow workers as well as in his contact with fellow citizens.

It is well to note that the curriculum is not designed to squeeze a four year engineering curriculum into two years. Course titles may bear resemblances to engineering curricula but the course content is of a different nature. Laboratory work will be emphasized and the theoretical work will be covered in detail. This is as it should be. The purpose of the curriculum is to produce individuals capable of taking "skeletonized plans and transform them in producible components and systems that satisfy a known need, both functionally and economically."

## The Schools

Classes will normally be taught in junior colleges which will offer both day and night sequences. The curricula will be taught by qualified instructors within the individual schools. Some high schools may conduct evening classes providing that they have a qualified staff.

## Historical Background

In 1956, the President of the United

*(Continued on Page 40)*



Maurice Roney illustrating a specific idea about the mechanical technician curriculum.



# Skimming Industrial Headlines

anticipator measures water content and temperature of the air, senses the atmospheric conditions which result in icing conditions, and warns the pilot while activating the anti-ice system. The little probe type sensor is mounted in the engine inlet duct or other suitable place to measure the air stream temperature and moisture. The system is of the continuous sensing rather than sampling type, needs no minimum air velocity to operate, and is insensitive to contamination such as dirt, oil, birds, and insects. The sensor also ignores low temperatures without moisture and high humidity without icing temperatures.

## Greaseless

The oil can and grease gun are indispensable for lubrication here on earth. But they won't be used to keep machines running on the moon or aboard long-lived spacecraft of the future, Westinghouse scientists point out.

In the high vacuum and extreme temperatures of outer space, oil and grease cannot protect the bearings of machines. The reason is that they oxidize, freeze, vaporize, or otherwise lose their normal lubricating ability.

Experiments show that a much better lubrication method under space conditions is simply to let a ball bearing run completely dry. A hard, tough plastic material from which part of the bearing itself is made is the only lubricant.

Ball bearing systems exhibit both rolling and sliding friction. The rolling friction is so low it causes negligible heating or bearing wear. However, sliding friction also occurs between the ball surfaces and the cage, or retainer, that holds them in place and between the cage and the other parts of the bearing. It is this friction that produces heating, wear, and bearing failure in dry bearing systems.

The new technique lowers this sliding friction by making the cage of a material have lubricating qualities even when dry. A plastic called PTFE (polytetrafluoroethylene), reinforced with glass or ceramic fibers and impregnated with molybdenum disulfide, is a typical cage material. During operation, a thin, dry lubricating film is formed, preventing the disastrous metal-to-metal sliding contact between the ball surfaces and components. The plastic cage maintains the film by metering minute quantities of dry lubricant to the loaded surfaces throughout the bearing's useful life. From 100 to 10,000 hours of continuous operation have been achieved with the dry system.

The data supports the use of such bearings in many applications where the environment makes conventional lubricants impractical. ◆◆◆

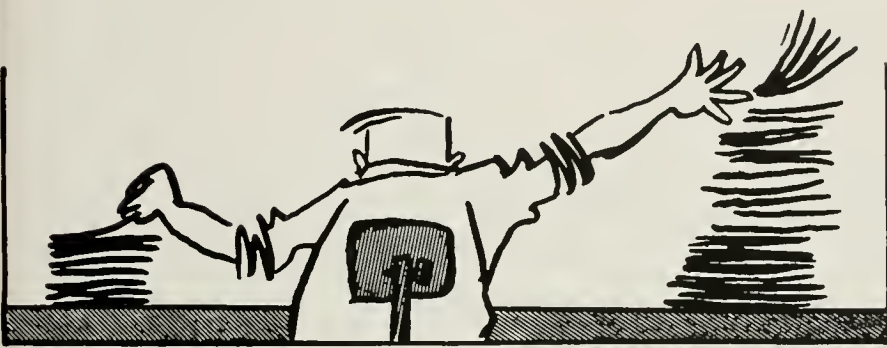

Edited by Art Becker, EE '66

## Live Wires

Completion of a series of barehand maintenance work tests on live lines carrying the world's highest transmission voltage—775,000 volts—proved the feasibility and safety of performing live-line work barehanded at voltages well above even the highest levels in use today.

The method, conceived in 1960 by American Electric Power Service Corporation and Ohio Brass Company, uses the principle that current will not flow between two points that have the same voltage. Linemen using the technique stand in non-conducting fiberglass buckets which are lifted to the line by an insulated boom. Safely insulated from the ground, the buckets' metal linings are connected to the line, making it possible for linemen to work directly on the line without the cumbersome equipment needed in conventional line work.

## Balancing Act

A British Army unit is making bridges that can support a jeep on just two steel cables stretched across a ravine, reports International Management. A flanged hub is bolted to a jeep's wheels. These are fitted over the wires, and a vehicle can drive across the bridge in safety, under its own power.

## Police Test Motor System

Los Angeles police cars now are testing the engine modifications devised by Chrysler Corporation engineers to burn automobile fuel more completely and thus reduce the loss out the tailpipe. The object of the test is to determine how much it reduces the smog-forming elements—olefins and nitrogen oxides—for a cost of less than \$10 per car.

The department agreed to test the 15 kits, designed for Plymouth and Dodge engines of 318-inch displacement, after a mechanical crew had installed one and found that it did not reduce performance or affect the starting of the motor.

Before installation of the modifications, each car is tested to determine how much pollution it emits. Then the carburetors are modified by installing leaner fuel jets, limiting the choke and setting the idle lean, while the distributors are modified to provide spark retardation during idle, and advance during deceleration.

## Cold Nose

Warning aircraft pilots of icing conditions in the atmosphere is the function of a new device produced by the Garrett AiResearch Phoenix division. Designed for greater flight safety, the ice



## A BROAD SPECTRUM OF OPPORTUNITY

MITRE works on the leading edge of a new technology — the creation of large computer-based systems (such as SAGE, NORAD, and BMEWS) that enable the military to detect attack and retaliate. Their purpose is to prevent war.

This work creates a wide range of career opportunities in many broad areas.

For instance, you might want to devote your talents to the full exploration of a single component in one system.

Perhaps, instead, you would prefer a more general assignment, such as the design of circuits, the development of radar, or the analysis of space hardware.

Or perhaps you would be more at home working on overall design of future command and control systems.

At MITRE the work ranges all the way from the detailed problems of electronic design to the abstract problems of national defense.

Whatever area you choose, you would find work that is important to your country.  
... and work that is creatively challenging.

You would have the opportunity to grow, professionally, in an atmosphere of free and objective inquiry.

At MITRE you would become identified with projects of the utmost national urgency — projects that offer a real challenge to the talented scientist and engineer.

The rewards are great. Salary and benefit plans are competitive. MITRE offers excellent Educational Assistance and Staff Scholar programs that give every encouragement to employees who wish to continue their academic interests. (At the present time, MITRE employees are attending 15 different institutions, including MIT, Harvard, Northeastern, and Boston University.)

Currently assignments are available in the following broad areas:

- Data Processing Development
- Computer Application
- SAGE Design and Testing
- Operations Research
- Communications
- Human Factors
- Range Instrumentation
- System Cost Analysis
- Advanced System Design
- Econometrics
- Radar Systems and Techniques
- Air Traffic Control
- Space Surveillance
- Space Systems Command and Control
- Astrodynamics

MITRE is located in pleasant, suburban Boston. Rewards are competitive. Minimum requirements, B.S., or M.S., or Ph.D. Write in confidence to Vice President — Technical Operations, The MITRE Corporation, Box 208, Dept. UIT 10 Bedford, Massachusetts.

THE  
**MITRE**  
CORPORATION

*An Equal Opportunity Employer*

MITRE is an independent, nonprofit corporation working with — not in competition with — industry. MITRE serves as Technical Advisor to the Air Force Electronic Systems Division, and is chartered to work for such other Government agencies as the Federal Aviation Agency.





## 2000 mph airliner...another engineering challenge!

On the drawing boards of aircraft engineers, plans are taking shape for a supersonic passenger jet — one that will fly from New York to London in just over 2 hours, at Mach-3 speeds of 2000 m.p.h. or more. The delta-shaped transport, flying at altitudes up to 80,000 feet, would make today's fastest airliners seem as pokey as stage-

coaches. And what size! Perhaps two hundred feet from nose to tail. Three stories tall.

Through the intensive research of the metallurgical engineer will come a metal for the skin of this mighty airliner. One that will be able to withstand critically high temperatures — up to 630°F — caused by supersonic speeds.

Challenging? An engineering career, such as metallurgy, is full of challenges. Whether it's exciting, new designs for a supersonic airliner, a gas-turbined car, a nuclear-powered ship, you'll be at work in a stimulating profession — one with room for advancement — one that promotes progress and economic growth.



## INTERNATIONAL NICKEL

The International Nickel Company, Inc., is the United States affiliate of The International Nickel Company of Canada, Limited — producer of Inco Nickel, Copper, Cobalt, Iron Ore, Tellerium, Selenium, Sulfur and Platinum, Palladium and Other Precious Metals.



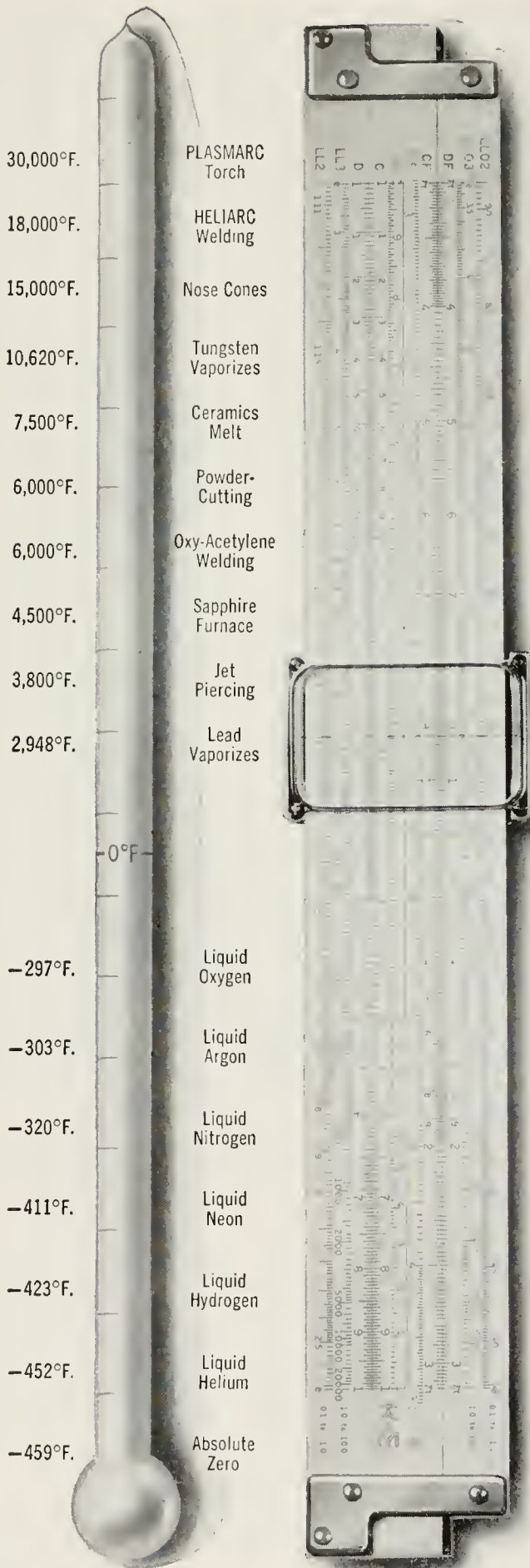

# A career at LINDE is a matter of degrees

Degrees—temperature as well as engineering—really matter at Linde Company.

LINDE, a leading commercial producer of industrial gases for over 50 years, is now engaged in many diverse industrial activities. Heat, cold, pressure, vacuum, and engineering talent are the basic creative tools used in continuing efforts to develop new products and advanced technological capabilities. Temperatures utilized may run as hot as 30,000°F., to as cold as -452°F. This work particularly requires the skills of Mechanical, Chemical, Metallurgical, Electrical, and Civil engineers.

There are excellent opportunities in programs in Cryogenics, Plasmas, Flame-Plating, Industrial Gases, Electronics, Molecular Sieves, Bio-Chemistry, Crystallography, and other technical areas.

You can look forward to a rewarding career in Research, Development, Design, Engineering, Production, Sales Engineering, Administration.

LINDE is a nationwide organization with offices, plants, factories and laboratories throughout the country. Where you work will largely depend upon the work you do.

**Research and Development:** LINDE has three technical centers at Buffalo, N. Y., Newark, N. J., and Indianapolis, Ind.

**Production Facilities:** LINDE operates production facilities in nearly every state of the Union.

**General Offices and Sales Offices:** LINDE's general offices are located in New York City; region sales offices are located in major cities throughout the country.

LINDE offers a progressive employment benefit program: relocation; Educational Refund Plan for advanced study in your field of interest. Promotion from within is a basic company policy. For further information, please contact Mr. E. R. Brown, Jr., Department 3742, Linde Company, Division of Union Carbide Corporation, 270 Park Avenue, New York 17, N. Y. All inquiries will receive prompt replies.

**LINDE COMPANY**



AN EQUAL-OPPORTUNITY EMPLOYER



Of interest to engineers and scientists

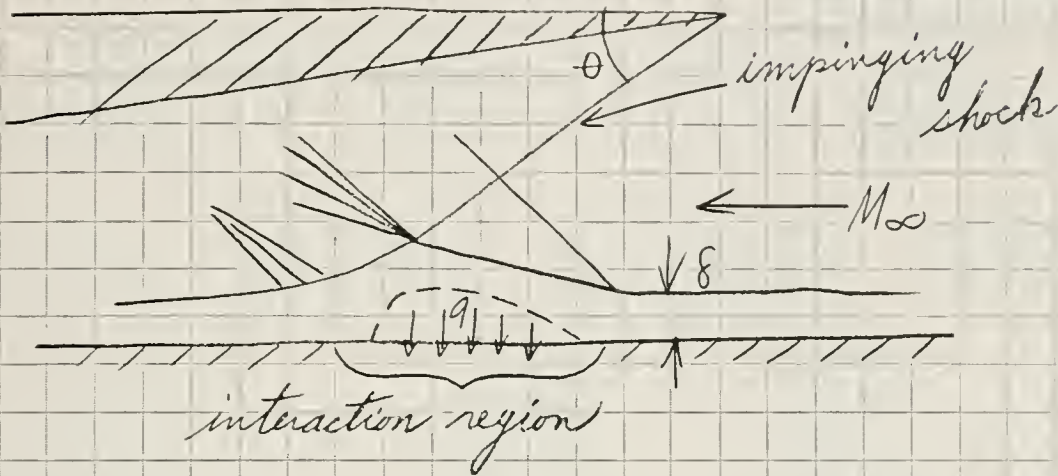

## AERO-THERMODYNAMICS

...among the more than 500 R & D programs under way at Douglas

Extensive research in advanced aero-thermodynamics is now being performed in Douglas laboratories.

Among current areas are dissociation non-equilibrium in supersonic flows; separated supersonic boundary layer phenomena; experimental boundary layer studies; heat transfer; turbulent mass transfer; and base flow.

Support of this program is provided through a multi-million dollar laboratory complex. Included is the Douglas Aerophysics Laboratory, one of the finest fluid dynamic research facilities in the aerospace industry.

### Of career interest to engineers and scientists

If you are seeking stimulating assignments and associates, full support of your activities, and an open door to advancement, investigate the outstanding career opportunities at Douglas.

Here, the emphasis is on the research and development that solve today's problems and lead to involvement in the biggest commercial aviation, defense and space projects of tomorrow. Also, scholarships and financial assistance are available to continue your studies in such nearby universities as U.C.L.A., Southern California and Cal Tech.

Send us your resume or fill out and mail the coupon. Within 15 days from the receipt of your letter, we will send you specific information on opportunities in your field at Douglas.



An equal opportunity employer

Mr. S. A. Amestoy  
Box 600-M  
Douglas Aircraft Company  
3000 Ocean Park Boulevard  
Santa Monica, California

Please send me full information on professional opportunities in my field at Douglas.

Name \_\_\_\_\_  
Engineering or scientific field \_\_\_\_\_  
Address \_\_\_\_\_  
City \_\_\_\_\_ State \_\_\_\_\_

# When is an Engineer a Portrait Painter



The answer is ALWAYS. His whole professional life is involved with sketching, drawing, drafting and rendering pictures of his ideas.

The working tool that gives the best graphic representation of his ideas is world-famous Castell #9000 drawing pencil. Milled by the exclusive microlet process for graphic saturation, it gives bold density of image. It glides across the paper without stumbling over gritty spots. Exceptionally strong in needlepoint or chisel point, it won't break under heavy pressure. Castell's 20 superb degrees, 8B to 10H, are controlled to a rigid standard of uniformity.

Many student and working engineers prefer Locktite Tel-A-Grade Holder with Castell #9030 Lead, identical in grade and quality to Castell drawing pencils.

Since engineers must rely on graphite to give expression to their ability, you'd be wise to use Castell, the drawing pencil of the masters. Make your selection at your college store today.

## A.W.FABER-CASTELL

Pencil Co., Inc.  
Newark 3, N. J.



# Begged, Borrowed and...

The little old lady bent over the crib: "Oooo, you look so sweet I could eat you."

"Like heck you could," the baby muttered. "You haven't got any teeth."

\* \* \*

A child's question: "If the Lord gives us our daily bread, and Santa Claus brings the Christmas presents, and the stork brings the babies, what's the use of having daddy around?"

\* \* \*

Sociologist: A guy who tells you stuff you already know in words you can't understand.

\* \* \*

Two CE's sat in a front seat watching the star of a Las Vegas show.

"I wonder who made her dress?" the first asked.

"It's hard to say," the second replied, "probably the police."

\* \* \*

The young ME who had not been married long, remarked at the dinner table one day: "Dear, I wish you could make bread like Mother used to make."

The bride smiled sweetly and answered: "Well, I wish you could make the dough that Father used to make!"

\* \* \*

Lady to police department: "Come quick. I just ran over an Engineering student."

Police Department: "Sorry lady, this is Sunday. You will have to wait till tomorrow to collect the bounty."

\* \* \*

The deans who think our jokes are rough

Would quickly change their views  
If they'd compare the ones we print  
With the ones we're scared to use.

\* \* \*

A rather ingenious engineer calls his girl "Definite integral" because he knows her limits.

\* \* \*

Hubby sneaked home at 3 a.m. His wife met him at the door.

"So! Home is the best place after all!" she snorted.

"I don't know about that," her mate replied, "but it's the only place open."

\* \* \*

First Communist: "Nice weather we are having."

Second Communist: "Yes, but the rich are having it too!"

Once upon a time a beautiful girl was walking through the woods when she came upon a poor little frog who spoke as follows:

"Lovely princess, once upon a time I was a handsome prince, but a big black witch turned me into a frog."

"Oh, that's terrible," said the beautiful girl. "Is there anything I can do to help you?"

"Yes, indeed," replied the frog. "If you take me home with you and put me on your pillow, I will be saved."

So the beautiful girl took the poor little frog home with her, and the next morning when she awoke, there beside her was a handsome young prince. And do you know, to this day her mother doesn't believe that story.

\* \* \*

A sorority is a group of girls living in one house, with a single purpose . . . to get more girls to live in one house, with a single purpose.

\* \* \*

A college graduate on his first job was handed a broom to sweep the floors for his first duty.

Grad: "But, I'm a college graduate."

Employer: "Oh, in that case, I'll show you how."

\* \* \*

"The traps on this course are very annoying," observed a member of the golfing foursome.

The one who was putting raised his head. "They certainly are," he commented. "Would you mind shutting yours?"

\* \* \*

Professor: "You in the back of the room, what was the date of the signing of the Declaration of Independence?"

"I dunno."

"You don't eh? Well then, do you know when the battle of Bull Run was fought?"

"Nope."

"You don't! I assigned this study last week. What were you doing last night?"

"I was out drinking beer with a couple of buddies."

"You were! How dare you stand there and tell me a thing like that! How do you expect to pass the course?"

"Wal, I don't mister. Ye see, I just come in to fix the radiator."



# WHAT'S THE OPPORTUNITY FOR YOU AT DU PONT?

It's good. Here's what DuPont offers:

**A chance to grow**, to build on your college training, as you work with, and learn from, men who have made their mark.

**A chance to advance** at a rate consistent with your growth and development.

**A chance to achieve** distinction in your field, on stimulating projects.

**Engineers, Chemists, Physicists, Mathematicians,**  
with B.S., M.S. or Ph.D.

Send the coupon below for more complete information on the opportunity for you at DuPont.

An equal-opportunity employer



BETTER THINGS FOR BETTER LIVING . . . THROUGH CHEMISTRY

---

**E. I. du Pont de Nemours & Co. (Inc.),** 2419-10 Nemours Building, Wilmington 98, Delaware

Please send me the booklets checked below:

- |   |   |
|---|---|
| <input type="checkbox"/> DuPont and the College Graduate  | <input type="checkbox"/> Your Engineering Opportunities at DuPont |
| <input type="checkbox"/> Mechanical Engineering at DuPont | <input type="checkbox"/> Chemical Engineering at DuPont           |

Name \_\_\_\_\_ Class \_\_\_\_\_ Course \_\_\_\_\_ Degree \_\_\_\_\_

College \_\_\_\_\_

Your Address \_\_\_\_\_ City \_\_\_\_\_ Zone \_\_\_\_\_ State \_\_\_\_\_

## Requirements Change . . .

*(Continued from Page 15)*

that in terms of almost all college and university entrance requirements a high school student would be qualified to enter college at the end of his third year in high school.

In this same respect, nationally-known educator Dr. James Bryant Conant, president emeritus of Harvard University, states in a booklet that the general requirements for high school graduation should include "four years of English; three or four years of social studies, including two years of history (one, American), and a senior course in American Problems or American Government; one year of mathematics (algebra or general mathematics); and at least one year of science, which might well be biology or general physical science."

In addition to the general requirements, talented students should be encouraged to take the necessary electives to round out their program to "four years of mathematics, three years of science, four years of one foreign language, and the required courses in English and social studies." Dr. Conant feels that it is necessary for the school boards to provide third and fourth year instruction in foreign languages, no matter how few enroll.

With the pressures that are being applied to the educational system to provide a better, more rounded education to each individual, it is apparent that more and more of the educational process that was once the responsibility of the colleges will be falling on the high schools. Realizing this responsibility, high school administrators are including more and more college courses in the curriculums of their schools.

Within this atmosphere of increasing pressure for improvement and increasing quantities of scientific knowledge, the College of Engineering of the University of Illinois has found it both necessary and desirable to increase the level of its entrance requirements, and the results of the study made by the College showed that the change was indeed possible and well justified.

## Educators Confer . . .

*(Continued from Page 32)*

States appointed a committee of scientists and engineers to investigate the shortage of scientific manpower. The committee reported, "The members of the President's Committee are unanimous in the belief that the manpower problems of technicians are at least as severe as the problems of scientists and engineers." The resulting National Defense Education Act of 1958 triggered

action in the State of Illinois. Mr. Walter J. Bartz was appointed Chief of Technical Education. He immediately sought aid from the University of Illinois College of Engineering. Dean Everett appointed an Engineering Technology Curriculum Advisory Committee with Professor Jerry S. Dobrovolny as chairman. The group grew into a standing committee in 1960. Conferences throughout the state were arranged and various curricula began to develop. Conferences continued into 1962. The need for training a competent staff has resulted in two National Science Foundation sponsored summer institutes to train teachers. Prof. Dobrovolny was the director of both these programs.

The work of the committee did not culminate in the recent conference. The progress of three years is embodied in the conference, but the work continues. A specific curriculum has been recommended, but it is not final. Improved teacher training facilities are still being sought.

The importance of a Mechanical Technician Curriculum is emphasized by the fact that engineers are willing to work vigorously toward training technicians. Who is in a better position to determine the type of support engineers need if it is not the engineer himself?



## CIVIL ENGINEERS:

**Prepare for your future in highway engineering—get the facts about new DEEP-STRENGTH (Asphalt-Base) pavement**

With today's "giant step forward" in pavement engineering—DEEP-STRENGTH (Asphalt-Base) pavement—there is need for engineers with a solid background in the fundamentals of Asphalt technology and pavement construction.

Because new DEEP-STRENGTH Asphalt-base construction provides the most durable, most economical pavement modern engineering science has developed, Interstate and primary superhighways in all parts of the country are being built with advanced design DEEP-STRENGTH Asphalt pavement.

Already, more than 90% of America's paved roads and streets are surfaced with Asphalt. And Asphalt pavements have successfully kept America's wheels rolling since 1876.

Your contribution—and reward—in our nation's vast road-building program can depend on **your** knowledge of modern Asphalt technology. So, prepare for your future **now**. Write for your free "Student Kit" about Asphalt technology.

**The Asphalt Institute**

College Park,  
Maryland





# Kodak beyond the snapshot...

(random notes)

## What makes hickory the way it is



This photomicrograph shows the basic structure of hickory wood. It was taken on a plain, ordinary microscope with a BROWNIE Camera. For details on this use of BROWNIE Cameras, request a copy of "Photomicrography with Simple Cameras" from Eastman Kodak Company, Sales Service Division, Rochester 4, N.Y. Everybody knows what a BROWNIE Camera is.

## Huntley with rope

May we please plant a little spore in the brain intended to grow into a career not previously contemplated?

Sound, businesslike outfits need well-grounded engineers to run their photographic operations. This doesn't necessarily mean making the candid shots at the boss's daughter's wedding.

We have made a 42-minute movie called "Photography at work... a progress report." (To show it, write Eastman Kodak Company, Professional Photographic Sales Division, Rochester 4, N.Y.)

Mr. Chet Huntley narrates. We take you inside a cake being baked in Dayton. We puzzle you with a monstrous camera intended to take pictures in Cincinnati without perspective. We show you how they test a new hydrofoil on Lake Washington and what nooks and crannies a camera can explore when fitted with fiber optics. We take you to lots of places, starting on a classy note with the hunt for anti-matter at Brookhaven.

If we create the impression that the great linear accelerator there is nothing but another camera accessory, do not conclude that perspective is being shunned in Rochester as well as in Cincinnati. There is a "low technology" that civilizations evolve over the millennia for hewing the wood and drawing the water of everyday life and a "high technology" that is called into existence by the demands of pure science and then very kindly lowers a rope to haul up the "low technology". Maybe 1520 feet of movie film is better than rope.

## The improvement of capacitors

Our polyester is different from other polyester. We add a cyclohexane ring to the unit structure, whereas other polyester is just poly(ethylene terephthalate). The added ring protects against moisture, raises the melting point, and gives customers some reasons of self-interest to seek out the trademarks KODEL on polyester fiber and TENITE on polyester molding granules.

When the president of Kodak visited the lab where, in addition, its electrical advantages were discovered, we set up ten .05- $\mu$ fd 200-v polyester capacitors for him, identical except that five had the ring and five didn't. We put them all in an oven at 185°C and applied 700 volts of dc across them. Within 3 minutes all five of the p(e t)'s had shorted out. This was the logical moment for the president to leave, but realism is company policy. The president wanted to watch the first of ours fail. It took 10 minutes. That was four years ago.

We then replaced 15 of the regular capacitors in a TV set with our kind and set it to running 9 hours a day, 7 days a week. All other components that failed we replaced. For the Electrical Insulation Show early this year, we removed the set from the room where the lab manager hides it and took it to Washington. It was the hit of the show. The coincidence that it happened to be the only TV set in the hall on the day when the first American was orbiting the earth might have helped focus attention on it. It would not have been a good place for a capacitor to blow.



MAKING CHEAP THINGS WORK WELL IS A GOOD LIFE.



SOPHISTICATED TECHNICAL PERSUASION IS A GOOD LIFE.



THE GOOD LIFE IS NOT ALWAYS FILLED WITH TENSION.

Plenty of lively work at Kodak researching, engineering, producing, and marketing all sorts of things.

**EASTMAN KODAK COMPANY**  
Rochester 4, N.Y.



**Manager—Engineering Recruiting**

# How to Make the Most of Your First Five Years

MR. HILL has managerial responsibility for General Electric's college recruiting activities for engineers, scientists, PhD's and technicians for the engineering function of the Company. Long active in technical personnel development within General Electric, he also serves as vice president of the Engineers' Council for Professional Development, board member of the Engineering Manpower Commission, director of the Engineering Societies Personnel Service and as an officer or member of a variety of technical societies.

**Q. Mr. Hill, I've heard that my first five years in industry may be the most critical of my career. Do you agree?**

A. Definitely. It is during this stage that you'll be sharpening your career objectives, broadening your knowledge and experience, finding your place in professional practice and developing work and study habits that you may follow throughout your career. It's a period fraught with challenge and opportunity—and possible pitfalls.

Recognizing the importance of this period, the Engineers' Council for Professional Development has published an excellent kit of material for young engineers. It is titled "Your First 5 Years." I would strongly recommend you obtain a copy.\*

**Q. What can I do to make best use of these important years?**

A. First of all, be sure that the company you join provides ample opportunity for professional development during this critical phase of your career.

Then, develop a planned, organized personal development program—tailored to your own strengths, weaknesses and aspirations—to make the most of these opportunities. This, of course, calls for a critical self appraisal, and periodic reappraisals. You will find an extremely useful guide for this purpose in the "First 5 Years" kit I just mentioned.

**Q. How does General Electric encourage self development during this period?**

A. In many ways. Because we recognize professional self-development as a never-ending process, we encourage technical employees to continue their education not only during their early years but throughout their careers.

We do this through a variety of programs and incentives. General Electric's Tuition Refund Program, for example, provides up to 100% reimbursement for tuition and fees incurred for graduate study. Another enables the selected graduate with proper qualifications to obtain a master's degree, tuition free, while earning up to 75% of his full-time salary. These programs are sup-

plemented by a wide range of technical and nontechnical in-plant courses conducted at the graduate level by recognized Company experts.

Frequent personal appraisals and encouragement for participation in professional societies are still other ways in which G.E. assists professional employees to develop their full potential.

**Q. What about training programs? Just how valuable are they to the young engineer?**

A. Quite valuable, generally. But there are exceptions. Many seniors and graduate students, for example, already have clearly defined career goals and professional interests and demonstrated abilities in a specific field. In such cases, direct placement in a specific position may be the better alternative.

Training programs, on the other hand, provide the opportunity to gain valuable on-the-job experience in several fields while broadening your base of knowledge through related course study. This kind of training enables you to bring your career objectives into sharp focus and provides a solid foundation for your development, whether your interests tend toward specialization or management. This is particularly true in a highly diversified company like General Electric where young technical graduates are exposed to many facets of engineering and to a variety of product areas.

**Q. What types of training programs does your company offer, Mr. Hill?**

A. General Electric conducts a number of them. Those attracting the majority of technical graduates are the Engineering and Science, Technical Marketing and Manufacturing Training Programs. Each includes on-the-job experience on full-time rotating assignments supplemented by a formal study curriculum.

**Q. You mentioned professional societies. Do you feel there is any advantage in joining early in your career?**

A. I do indeed. In fact, I would recommend you join a student chapter on your campus now if you haven't already done so.

Professional societies offer the young engineer many opportunities to expand his fund of knowledge through association with leaders in his profession, to gain recognition in his field, and to make a real contribution to his profession. Because General Electric benefits directly, the Company often helps defray expenses incurred by professional employees engaged in the activities of these organizations.

**Q. Is there anything I can do now to better prepare myself for the transition from college campus to industry?**

A. There are many things, naturally, most of which you are already doing in the course of your education.

But there is one important area you may be overlooking. I would suggest you recognize now that your job—whatever it is—is going to be made easier by the ability to communicate . . . effectively. Learn to sell yourself and your ideas. Our own experience at General Electric—and industry-wide surveys as well—indicates that the lack of this ability can be one of the major shortcomings of young technical graduates.

\*The kit "Your First 5 Years," published by the Engineers' Council for Professional Development, normally sells for \$2.00. While our limited supply lasts, however, you may obtain a copy by simply writing General Electric Company, Section 699-04, Schenectady, New York.

(An equal opportunity employer.)

*Progress Is Our Most Important Product*

**GENERAL  ELECTRIC**



Coll.



NO. 2-25¢

UNIVERSITY OF ILLINOIS

ILLINOIS

TECHNOGRAPH



### **Super magnets may help harness the power of the H-bomb**

If the energy that makes an H-bomb could be released in a controlled flow, man would have an almost limitless source of electric power. But the "if" is a big one. It means, among other things, building a container to hold 100-million degree temperatures . . . hot enough to vaporize any known material. Theoretically, this container problem could be solved by holding the hydrogen reaction inside a powerful magnetic field, a sort of "magnetic bottle." But such a magnetic bottle would require a series of huge costly magnets consuming a powerhouse full of electricity. However, Westinghouse is already marketing a fist-sized super conducting magnet that runs on virtually no power, yet produces a field twice as intense as a conventional magnet weighing 20 tons. Scientists believe that future developments of these super magnets may provide the answer to the problem of harnessing the energy of a hydrogen reaction. Perhaps you would be interested in helping to develop this and many other challenging projects at Westinghouse, an equal opportunity employer. For more information, see our representative when he visits your campus, or write to L. H. Noggle, Westinghouse Educational Center, Pittsburgh 21, Pennsylvania. You can be sure . . . if it's Westinghouse.

**Westinghouse**





**Editor-in-Chief**  
Wayne W. Crouch

**Associate Editor**  
Gary M. Daymon

**Office Manager**  
Thelma Allen

**Production Manager**  
Scott Weaver

**Circulation Manager**  
Gary Bilow

**Editorial Staff**  
Art Becker  
Larry Druffel  
Ted Morange  
Bill Small  
James Walters

**Business Staff**  
Phillip Johnson  
Wayne Worthington

**Production Staff**  
Mike Glowacz

**Circulation Staff**  
Ken Biss  
George Muellner  
Paul Gihring

**Photography**  
Jay Dickinson  
Joe Figueira

**Art Staff**  
Jim Simon

**Advisors**  
R. W. Bohl  
P. Bryant  
W. M. Hudson  
E. C. McClintock

# THE ILLINOIS TECHNOGRAPH

Volume 78; Number 2

November, 1962

## Table of Contents

### ARTICLES

The Wankel Rotary Engine .....	Boyd Harrold	10
da Who? da Vinci .....	Bill Small illustrations by Bill Steiner	14
Engineering Employment Opportunities .....	Gary Daymon	18
Engineering Alumni Convention .....	Art Becker	24

• • • • •

### FEATURES

TECH Says .....		5
The Dean Speaks .....	Dean H. L. Wakeland	7
News and Views at the U. of I. ....	Gary Daymon	22
Technacutie .....	photos by Dickenson and Figueira	26
Skimming Industrial Headlines .....	Art Becker	29
Engineering Calendar .....		38
Jokes .....		40

### MEMBERS OF ENGINEERING COLLEGE MAGAZINES ASSOCIATED

Chairman: J. Gale Chumley  
Louisiana Polytechnic Institute  
Ruston, Louisiana

Arkansas Engineer, Cincinnati Cooperative Engineer, City College Vector, Colorado Engineer, Cornell Engineer, Denver Engineer, Drexel Technical Journal, Georgia Tech Engineer, Illinois Technograph, Iowa Engineer, Iowa Transit, Kansas Engineer, Kansas State Engineer, Kentucky Engineer, Louisiana State University Engineer, Louisiana Tech Engineer, Manhattan Engineer, Marquette Engineer, Michigan Technic, Minnesota Technologist, Missouri Shanrock, Nebraska Blueprint, New York University Quadrangle, North Dakota Engineer, Northwestern Engineer, Notre Dame Technical Review, Ohio State Engineer, Oklahoma State Engineer, Pittsburgh Skyscraper, Purdue Engineer, RPI Engineer, Rochester Indicator, SC Engineer, Rose Technic, Southern Engineer, Spartan Engineer, Texas A & M Engineer, Washington Engineer, WSC Technometer, Wayne Engineer, and Wisconsin Engineer.

### The Cover: by Robert Yackel

Bob's rendition of the Wankel Engine in action gives this month's cover a brilliant sense of action.

Copyright, 1962, by Illini Publishing Co. Published eight times during the year (October, November, December, January, February, March, April and May) by the Illini Publishing Company. Entered as second class matter, October 30, 1920, at the post office at Urbana, Illinois, under the Act of March 3, 1879. Office 215 Engineering Hall, Urbana, Illinois. Subscriptions \$1.50 per year. Single copy 25 cents. All rights reserved by *The Illinois Technograph*. Publisher's Representative -- Littell-Murray-Barnhill, Inc., 737 North Michigan Avenue, Chicago 11, Ill., 369 Lexington Ave., New York 17, New York.

# POWER APPLICATIONS UNLIMITED



*Electrically heated church*

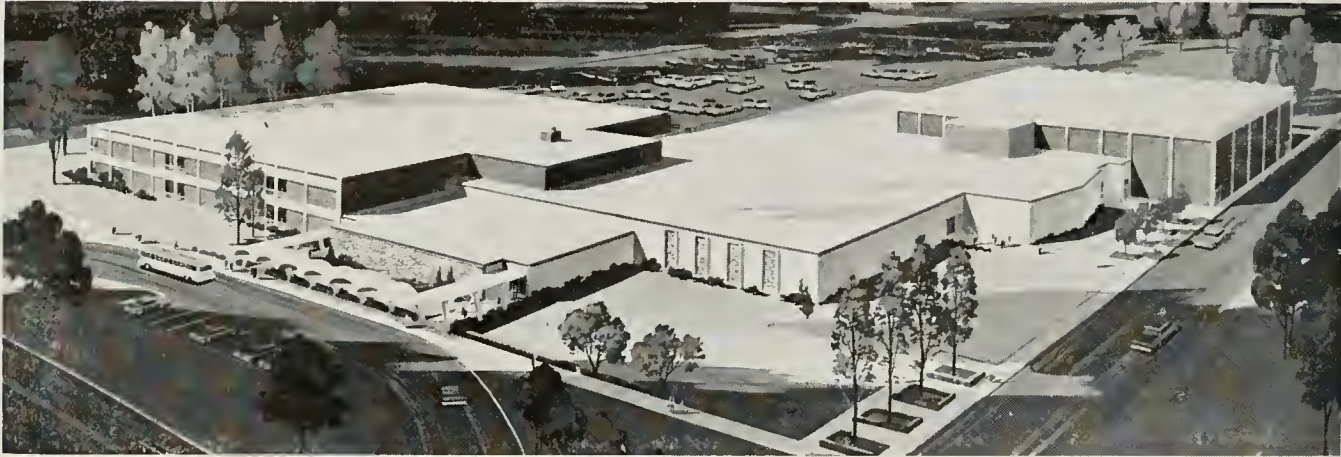

*All-Electric high school*

## LET YOUR IMAGINATION WORK

"Nothing new under the sun" . . . but always a better way to apply what we know. This might be the motto of a power sales engineer. Each of these pictures shows an economically sound, practical, even revolutionary solution to problems in the service area of the Wisconsin Electric Power Company system. The power sales engineer's job is to add new possibilities to the already myriad uses for electricity.

The electrically heated Milwaukee church cost less to build and competes favorably in heating costs with similar churches using other fuels. Heat is programmed by electric time clock . . . The new Kimberly, Wis., high school will "climate-control" during the school year for the cost of just heating a conventional school. Electric air-conditioning permits unusual compact design . . . Electronic sortation unit at General Merchandise Company, Milwaukee, processes most orders the day they are received, using only 12 employes . . . Northernmost of its type and one of the world's largest heat pump installations is being installed in the new Headquarters and Research Center of the Allen-Bradley Company, Milwaukee.

See us about an interesting career in power sales — where engineering and sales ability are limited only by your imagination.



*Electronic sortation line*

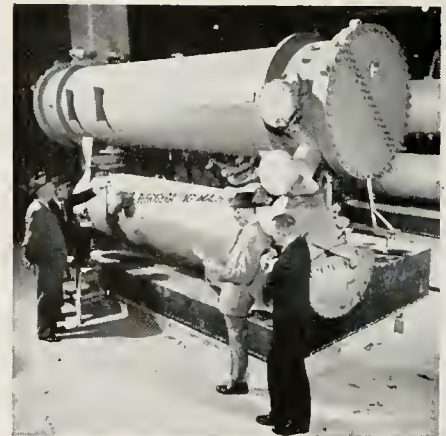

*Giant heat pump installation*

## WISCONSIN ELECTRIC POWER COMPANY SYSTEM

Wisconsin Electric Power Co.  
MILWAUKEE, WIS.

Wisconsin Michigan Power Co.  
APPLETON, WIS.

Wisconsin Natural Gas Co.  
RACINE, WIS.

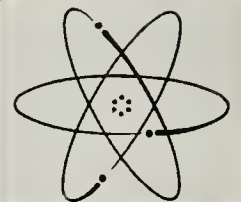





## ...suddenly, new hope in life

A man lies on the operating table, crippled with the exhausting tremors of Parkinson's disease. The surgeon guides a slender tube deep inside the patient's brain until it reaches the target area. Then liquid nitrogen, at 320 degrees below zero F., is fed to the end of the tube. Suddenly the trembling stops. The unearthly cold kills the diseased cells . . . and a once desperate human being has been given a new chance in life. ► Medical reports have indicated that not only Parkinson's disease but also other disorders causing tremor or rigidity have responded to this new technique in brain surgery. The operation has been described as easier on the patients than previous surgery, and they have been able to leave the hospital in a surprisingly short time. Also, encouraging results are reported on the use of cryosurgery, as it is called, to destroy diseased cells in other parts of the body. ► Through its division, Linde Company, Union Carbide was called upon by medical scientists for help in designing and making equipment to deliver and control the critical cold required in this new surgery. This dramatic use of cryogenics, the science of cold, is an example of how research by the people of Union Carbide helps lead to a better tomorrow.

### A HAND IN THINGS TO COME

*For information describing the work in cryosurgery done at the Neurosurgical Department of St. Barnabas Hospital, New York, write to:*

*Union Carbide Corporation, 270 Park Avenue, New York 17, N. Y. In Canada: Union Carbide Canada Limited, Toronto.*

**UNION  
CARBIDE**





## Must you join a giant company to work on big projects?

Take the Nuclear Ship Savannah. Many giant companies helped build her. Many smaller companies also contributed significantly to her success. In fact, her most significant feature—the reactor—was designed and built by Babcock & Wilcox.

*B&W is large enough to win contracts for big projects.* 1961 sales, for example, were more than \$300 million. And every year, B&W invests many millions of dollars in re-

search and development. B&W offers many other advantages of the large company: formal training program, paid tuitions, wide variety of job openings (16 plants in 8 states), plus the security and benefits of a large 95-year-old organization.

*B&W is small enough to give you a chance to work on big projects early in your career.* There are 150 larger industrial companies in the U.S. Growth opportunities are enor-

mous. Yet only 58 bachelor-level students will be hired in 1963.

B&W has interesting job openings for graduate and undergraduate engineers and scientists, including M.E., E.E., Ch.E., Met.E., Cer.E., chemist and physicists. You can get more information by writing J.W. Andeen, The Babcock & Wilcox Co., 161 E. 42nd St., New York 17, N.Y.

**Babcock & Wilcox**



# Which Shall It Be—

## STATIC or PROGRESSIVE Activities?

With over 240 extra-curricular activities, clubs, and honoraries to choose from, virtually every student participates in at least one extra-curricular activity during his college career — indeed, most students actively engage in more than one. Yet when does a student obtain that feeling of satisfaction which results from a job well done?

Quite often students become so engulfed in the time consuming routine phases of their activity that they fail to take an overall long-range connoisseur's view of their efforts. True, following the guidelines established by your predecessors is often more economical and sometimes more desirable, yet there is no guarantee the direction of movement or the standards of development are the most current, economical, or constructive. For instance, TECH has been published since 1885. Yet the original, 6"x9", highly technical, civil engineering quarterly publication is quite a contrast to the 1962, 8<sup>3</sup>/<sub>4</sub>"x11<sup>1</sup>/<sub>2</sub>", monthly publication designed to interest all technically oriented students. These significant changes were clearly

not automatic but the product of careful and conscious student planning.

Understandably it is easier to follow a rut and accelerate with no concern for direction. But before a student puts his efforts to the grindstone, he should pause for a breath of virgin ozone and a moment of rumination . . . collect his thoughts and opinions along with his predecessors' and advisors' — then think, ask, listen, and utilize.

Only after he has exposed and scrutinized all avenues of improvement and utilized all his resources can a student truly exonerate himself and enjoy the ultimate satisfaction of a job well done. Whether the scrutinizing takes the form of conferences, telephone calls, personal contacts, or all three is unimportant. The main requirement is that it is conscious and continuous. TECH is sure other students will find as we have that a seemingly routine activity can become a progressive, vibrant, and edifying experience requiring less effort and displaying a more industrious product.

## PROGRESSIVE!



The Tech staff and guests enjoyed dinner in Allerton House's cafeteria.



The conference was conducted as an informal round table discussion.

As a part of its constant quest for improvement, the staff of the ILLINOIS TECHNOGRAPH held its annual conference at the University of Illinois' Allerton Conference Center, Monticello. Guest speakers were: Dean William L. Everitt, College of Engineering, who represented the administration's viewpoint; Paul McMichael, Publisher, Illini Publishing Company, who elucidated TECHNOGRAPH'S relationship with the IPC; and TECH'S faculty advisors — Prof. Robert W. Bohl, Metallurgy; Prof. E. C. McClintock, General Engineering (technical writing); and Paul Bryant, Engineering Publications Office.

The morning session was highlighted with a round-table discussion. The major topics discussed were the magazine's publication policy, circulation coverage, advertising outlets, continuity of staffs, and other aspects pertinent to a successful magazine. A new system for staff unity was developed along with a reorganization of the editorial staff to give it greater responsibilities. An improved public relations department was organized and improved circulation procedures were adopted to reach more campus engineering students and faculty members. New ideas for obtaining local as well as national advertising were also discussed.

The afternoon session was utilized to orient new staff members and plot an appropriate course for the current semester. Each staff manager provided an epitome of his staff's responsibilities with an emphasis on the areas of potential improvement.

G. M. D.

When a space vehicle slants back into the earth's atmosphere at mission's end, a curtain of silence lasting minutes closes between it and its tracking earth stations. A similar communications blackout occurs during the space firing of rocket engines. □ Villain is intense heat generated during re-entry and rocket firing which leads to ionization of atoms and disturbs or

## ELECTRONIC BLACKOUT

...A STIMULATING AREA FOR CREATIVE ENGINEERS

blots out radio frequencies. □ Because this phenomenon represents an obstacle to remote control of space vehicles, Douglas scientists are studying its exact causes. Work is in progress on methods of modulating or eliminating this interference.

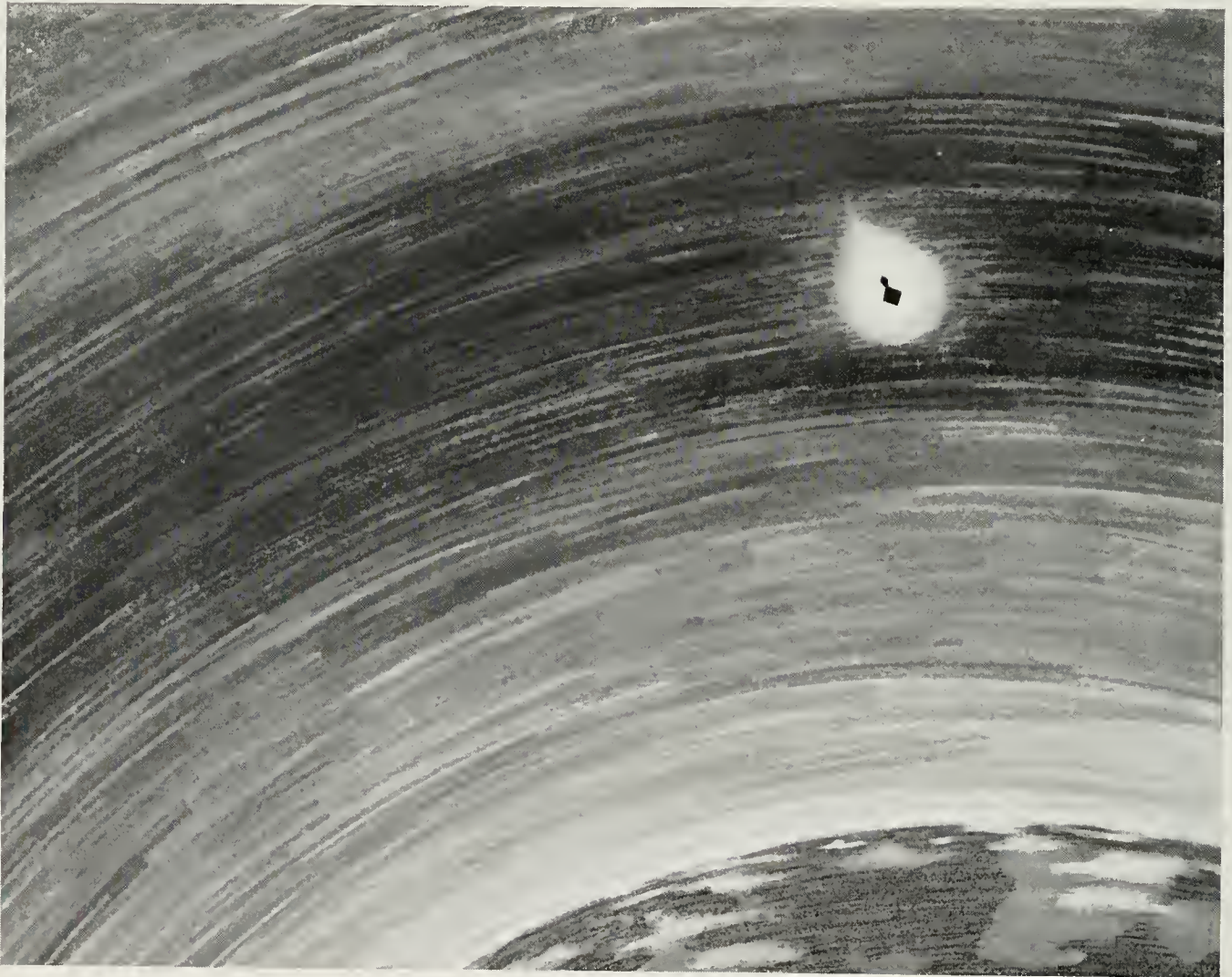

The above is only one of hundreds of interesting assignment areas at Douglas. If you are seeking a stimulating career with an organization in the thick of the most vital programs of today and tomorrow, we invite you to contact us. Write to Mr. S. A. Amestoy, Douglas Aircraft Company, 3000 Ocean Park Boulevard, Santa Monica, California, Dept. 600-M.

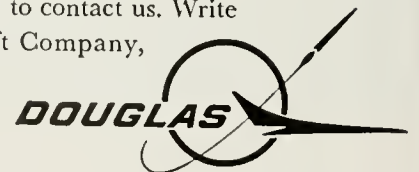



# STARTING SALARIES AND ADVANCEMENTS

By Dean H. L. Wakeland

"Will I be able to find employment when I graduate?" "Is the demand for engineers really as great as the general public is led to believe?" "Can graduate education be justified financially?" "What kind of salary increases can engineers expect?"

These are only a few of the questions commonly asked by undergraduate engineering students and by educational counselors. Recent surveys published by Mrs. Pauline Chapman, Placement Director in the College of Engineering at the University of Illinois provide either complete or partial answers to many of these questions.

Mrs. Chapman's Annual Survey (Table 1) shows the trend towards increased salaries for students completing a bachelors degree. The increase from \$481 in 1957 to \$577 in 1962 is nearly a 20% increase and is slightly greater than the increase in the cost of living or general economy in the same period of time.

The fact that we have nearly as many companies interviewing as we have seniors indicates that the acceptance and demand for University of Illinois engineering graduates is excellent. If each company interviewing were able to hire one engineer, each year, we would just barely have enough graduates. The total number of interviews and the number of interviews per company, per day, have not changed significantly during the past five years, indicating that the demand for engineers has been consistent during this period.

It is estimated that five engineering positions exist for each engineering graduate. Yet, with such a large demand engineering enrollments have continued to drop during the past few years. Although high salaries should not be used to lure young people into engineering, it should be pointed out that the high salaries indicate a great demand which would not exist if the opportunities were not great.

Each year about 25% of the graduates enter aircraft and missile industries and about 25% go to electronics and electrical equipment companies. It is also estimated that nearly half of all our engineers enter industries directly related to the national defense effort.

Mrs. Chapman has also studied the advancement and movement of University of Illinois engineering graduates. Table 2 lists the results of a 5 year summary. The average starting salary is given for each type of engineering graduate in 1957. The next column lists the average salary for the same group in 1962. The average increase in salary for all types in this 5 year period was 62% or from \$476 per month to \$771.

The survey also indicates that it pays to complete graduate study. On the average, the engineer with a master's degree is making \$61 more per month than one with only a bachelors degree, and those with doctors degrees receive \$217 more. Although income may have been lost for advanced degree personnel during the educational period, they are now commanding better salaries, after only 1 to 4 years on the job, and will probably advance at a more rapid rate. Even if the differential salaries were to stay the same, on the basis of these figures the doctors degree would pay for itself in approximately 13 years.

It is popularly believed that new engineering graduates will change jobs several times during their first few years, but the survey did not confirm this belief. Better than half of the 1957 graduates (56%) are still working for their original employer, 29% made one change, 11% two changes, and 4 per cent three or more changes. Nearly half of these changes were made in the third or fourth year of employment.

However, do not let average figures mislead you, for progress and advancement are still an individual matter. For instance, one electrical engineer that graduated in 1957 is now making \$2000 per month while another is making only \$585 per month. Each graduate will advance only on the basis of his own proven ability.

The survey simply confirms many common beliefs held by students—many engineering opportunities exist—every qualified engineering graduate finds employment—engineering salaries are high and financial advancement good—graduate education is financially rewarding—engineering graduates find stable employment—and industry is not so cold and hard hearted as many are led to believe.

There is no doubt, however, that the young man who adequately prepares himself and gains as much education as possible in his earlier years will receive greater financial rewards and enjoy a more interesting and fuller career. ♦♦♦

Table 1

Five Year Salary Survey of the 1957 Graduates from the College of Engineering, University of Illinois

Engineering Field	Starting Salary 1957	Present Salaries (1962)		
		B.S.	M.S.	Ph.D.
Aeronautical	\$505	\$812	\$814	None
Agricultural	\$424	\$657	\$591	None
Ceramic	\$465	\$682	\$817	None
Civil	\$455	\$667	\$748	None
Electrical	\$487	\$843	\$898	\$1,034
Engineering Physics	\$464	\$900	\$909	\$1,167
General	\$456	\$745	\$600	None
Industrial	\$459	\$715	\$805	\$870
Mechanical	\$473	\$733	\$771	None
Metallurgical	\$481	\$733	\$775	\$840
Mining	\$495	\$638	None	None
All Fields	\$477	\$757	\$818	\$964



Up-to-date road maps and special vacation guides are available at the more than 22,000 Phillips 66 Service Stations.

## Interested in going places?

Phillips, as a major producer and marketer of automotive fuels and lubricants, likes to see every car owner go places. As a company that has grown from a small crude oil producer in 1917 to its present position as a major oil company engaged in many diverse and expanding enterprises, we also like to see career-minded employees "going places."

Today, Phillips employees continue to "go places" because their company is actively engaged in such growth enterprises as the production and marketing of polyethylene plastics, synthetic rubber, oil furnace carbon black, and nitrogen fertilizers . . . as well as being one of America's most progressive marketers of petroleum products. Phillips is also the world's largest producer-marketer of liquefied petroleum gas; leads the oil industry in the production of natural gas and the sale of natural gas liquids. The company is an oil industry leader in research, development, and patents. Phillips also produces several hundred special hydrocarbon compounds for the chemical industry.

Outstanding career opportunities with Phillips Petroleum Company are made possible because of its growth and diversification. Opportunities exist for engineers, chemists, geologists, mathematicians and physicists . . . in the fields of geology, geophysics, oil and gas production, computer programming, petroleum processing, marketing of petroleum products, and transportation.

College graduates who seek opportunity to assume greater responsibilities will find a career with Phillips rewarding and exciting. Phillips is an equal opportunity employer. For complete information write to our Employee Relations Department. Arrangements for an interview with a Phillips Representative can be made through your College Placement Office.



**PHILLIPS PETROLEUM COMPANY**  
Bartlesville, Oklahoma





## The sky is not your limit

You're looking at an historic first — a 238,857 mile lunar bull's-eye scored by a team of scientists from Raytheon and the Massachusetts Institute of Technology, using a powerful new Raytheon-developed laser light beam. This success typifies the far-ranging variety of advanced projects challenging young engineers and scientists at Raytheon today.

For EE's, math and physics majors — in all the varied fields of engineering and science — Raytheon offers unlimited opportunity for growth and continuous advancement.

Personal career development is encouraged by a wide variety of educational assistance . . . seminars, special courses to meet individual needs and work-study programs leading to advanced degrees from renowned universities are all available.

You may well qualify for one of the exciting, career-building projects underway at Raytheon. Originality, imagination and high technical competence are your tools — the rewards are prompt and appropriate for success.

For detailed information, arrange an on-campus interview through your placement director or write G. W. Lewis, Manager of College Relations, Raytheon Company, Executive Offices, Lexington 73, Mass. An Equal Opportunity Employer.

**Raytheon offers opportunities for BS, MS and Ph.D. levels in**

- Solid State
- Microwave Electronics
- Infrared
- Lasers
- Communication & Data Processing
- Radar
- Missile Systems
- Sonar
- Electron Tube Technology



# THE WANKEL ROTARY ENGINE

Edited by Bill Small

from an article by  
Boyd Harrold

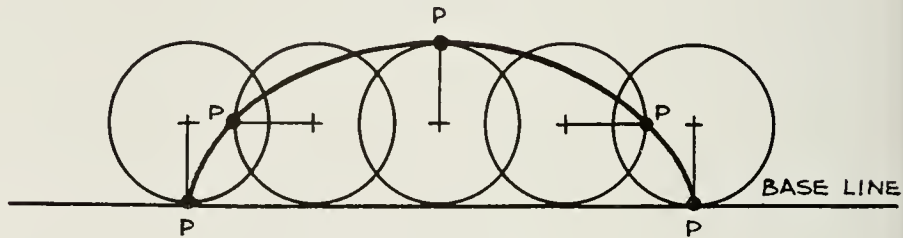

Figure 1 Cycloid

N. S. U. Werke of Neckarsulm, Germany, amazed the automotive industry in 1959 by introducing an unusual engine which replaces the shuttle of ordinary pistons by a three lobed rotor. This combination of features of the common internal combustion engine and the turbine promises a 300% increase in efficiency of the power per weight and size ratio. Also, it is quiet, almost vibrationless, economical to manufacture and operate, and relatively

maintenance-free since it has only two major moving parts. Experimental models of this unique rotary gasoline engine, designed by Felix Wankel for the German manufacturer of motor vehicles including the Prinz automobile, are already in use driving pumps, and others will power the Prinz in the near future.

Curtiss-Wright has acquired a limited franchise in the United States for production of models over 100 hp. By 1961 they had built models with a 61.1

cubic inch chamber displacement which, it is believed, have been tested for several thousand hours without causing enough wear to have a significant effect on performance. Curtiss-Wright is said to be able to start production line operation in the near future. It is not yet known whether air-craft, marine, and industrial engines of this type will be produced. Unfortunately, they have not released test data, but it is believed that some decrease in the exceptional per-

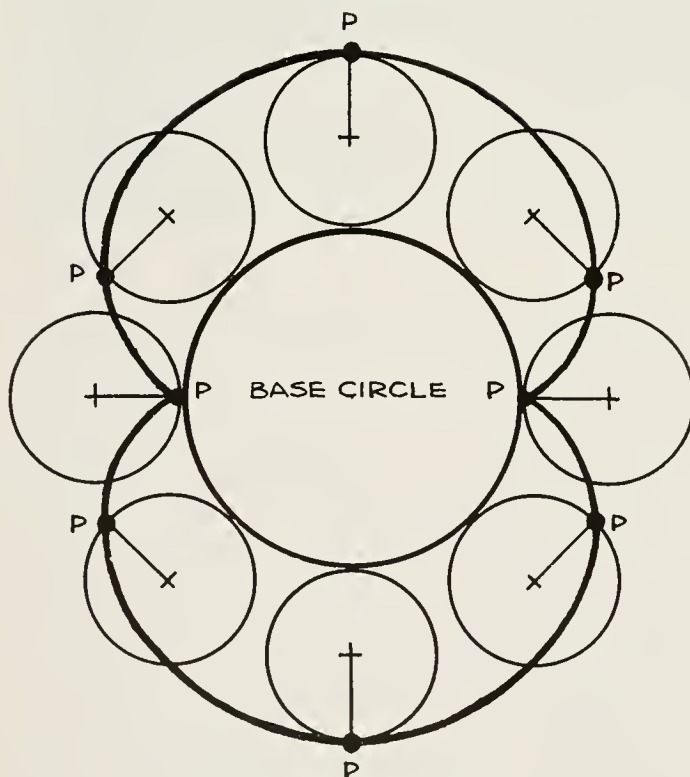

Figure 2 Epicycloid

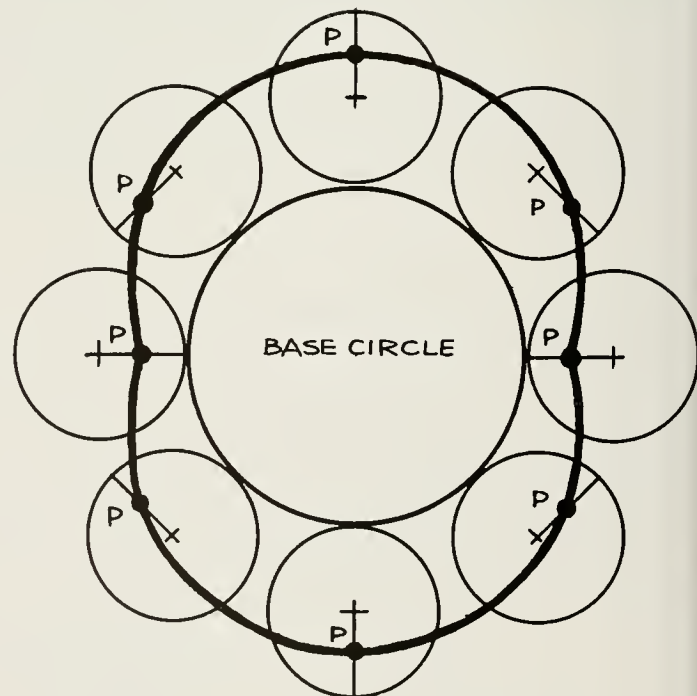

Figure 3 Epticoid



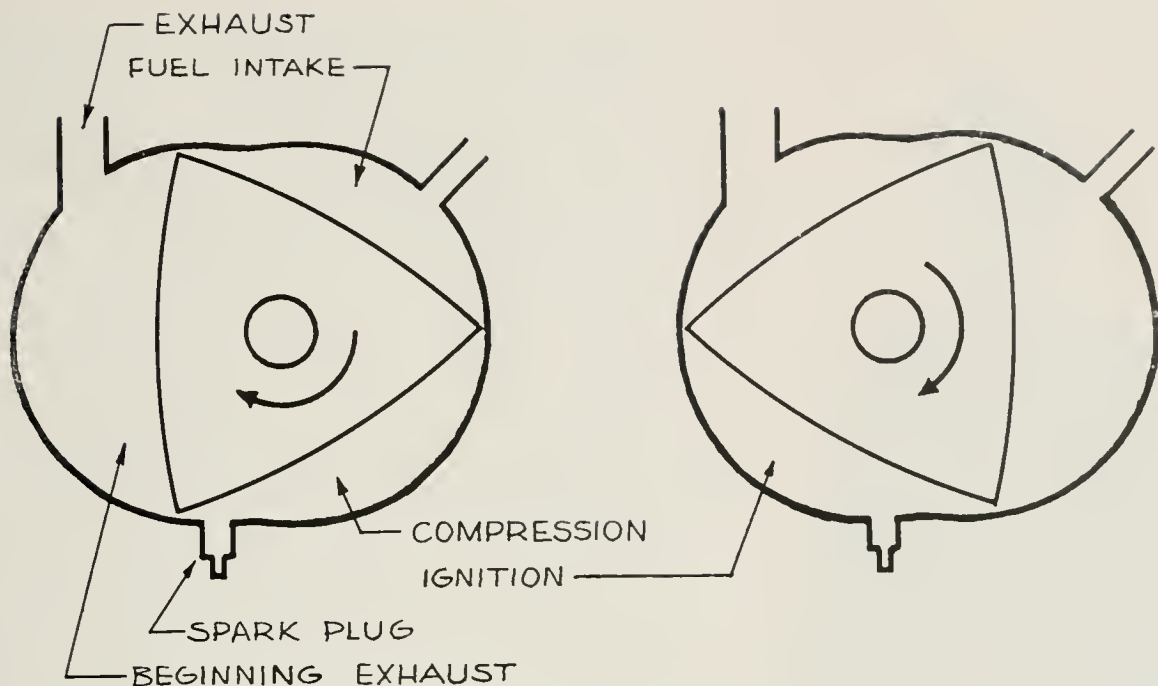

Figure 4 Firing Cycle

formance of the engine will occur in the larger models.

In a sense, the engine does have pistons forced by the ignition of a gas-air mixture, but the roughly triangular "piston" rotates eccentrically within an epitrochoidal combustion chamber, its three apexes always touching the walls. This creates three cavities within the chamber which constantly vary in size to complete the operations of a cycle: fuel intake, compression, expansion after ignition, and, finally, exhaust. Though the operation is standard four cycle, there are three power "strokes" for each revolution.

A definition of an epitrochoidal chamber can be effected progressing from the definitions of simpler figures, the cycloid and epicycloid. The cycloid (Fig. 1) is the locus traced by a point (P) on the circumference of a circle while it is rolling along a straight line. If this circle were rolling around the circumference of another (base circle), the figure produced would be an epicycloid (Fig. 2). If the point (P) lies neither on the circumference nor at the center of the rolling circle, the figure traced would be a prolate cycloid or epitrochoid, the shape of the N. S. U.-Wankel chamber (Fig. 3). The ratio of the base and rolling circle diameters must be exactly 2:1 for the engine chamber.

The unusual design of the N. S. U.-Wankel engine gives these improved performance features:

\*Concentrated power, a high ratio of horsepower to displacement. The first experimental engine developed 3.8 horsepower per cubic inch. In comparison,

the average U. S. stock-car engine seldom produces over one horsepower for the same displacement. If the ratio would hold true for larger models, a rotary unit the size of a 1962 Ford engine would yield more than 1500 horsepower. Such theoretical scaling-up, however, is not likely to prove accurate.

\*Light weight. The first engine contained 1.3 pounds of metal for every unit of horsepower. Thus, a pounds to power ratio of .83 is possible.

\*Low initial cost, depending, of course, on the pricing practices of the manufacturer. Despite the unusual shape of the combustion chamber and the precision sealing it demands, N. S. U. claims the engine would be easily mass-produced. The moving parts are simple: a triangular rotor and straight output shaft.

\*Economy in operation. In an engine having a displacement of 250 cubic cm. and developing 31 bhp at 5,500 rpm, the fuel consumption is 0.5-0.6 lb bhp-hr comparing favorably with the more common engine displacement of 498 cubic cm. which has a fuel consumption of 0.52-0.56 lb bhp-hr. Lubrication is effected by adding small amounts of oil to the gas (2.5 ounces per gallon). More astonishing, the engine functions well on gasolines of octane ratings as low as 43. Yet the compression ratio is relatively high, between 7.5 and 8.5:1. Impressive resistance to damaging "knocking" is basic to the design; intake is on one side, exhaust on the other. There are no "hot spots" (eg. the exhaust valve in ordinary engines) to detonate incoming fuel.

\*Simple ignition system. The ignition system follows closely the pattern of motorcycles and has caused little difficulty. However, the spark plug must have a higher heat value than the one used in ordinary piston engines.

\*Little vibration. There is a pleasant absence of the "shake" of reciprocating machinery, although the smoothness of a turbine is not achieved because there is a counter-weight and an off-center rotor.

\*Responsiveness. The greatest power is delivered at the high rpm of which the engine is capable, but it also delivers substantial output at low speeds since it has a minimal torque curve. This makes it possible to take inclines and turns with little down shifting, possibly allowing the use of a simple transmission.

On the other hand, the unusual design of the engine presents the following difficulties:

\*Size limitations. Some engineers suspect that the larger rotary engines will not equal the performance of the 7.6 cubic inch prototype or that of the 250 cubic cm. model described above. Since Curtiss-Wright has the only large engine (61.1 cubic inches) and refuses to release any data on it, this is still an open question.

\*Cooling. The combustion chamber has a water jacket like an ordinary cylinder, but the rotor is partially cooled by incoming fuel which must enter on the side away from the combustion area, decreasing its effectiveness.

(Continued on page 33, column 1)



# Engineers

*In Choosing a Career,  
Consider these  
Advantages—*

**Location:** Fisher is basically an "Engineering" company with 1,500 employees located in a pleasant midwest community of 22,000. It's less than 10 minutes to the Fisher plant from any home in Marshalltown.

**Type of work:** You'll become a member of an engineering team that has produced some of the outstanding developments in the field of automatic pressure and liquid level controls.

**Growth:** Fisher's products are key elements in automation which assures the company's growth because of the rapid expansion of automation in virtually every industry.

**Advancement:** Your opportunity is unlimited. It is company policy to promote from within; and most Fisher department heads are engineers.

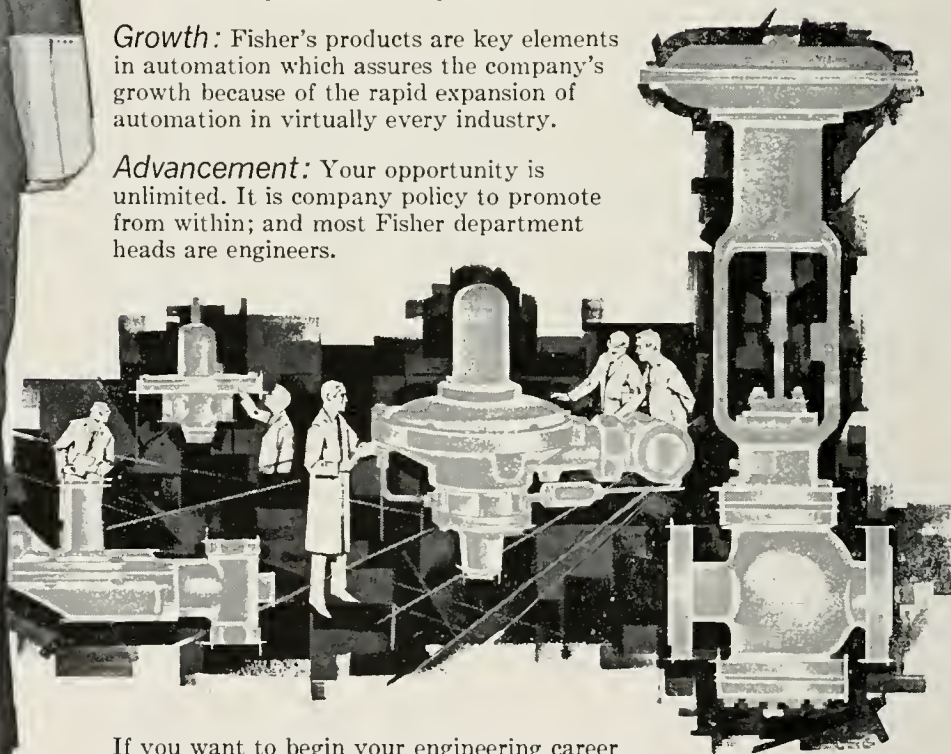

If you want to begin your engineering career with one of the nation's foremost research and development departments in the control of fluids, consult your placement office or write directly to Mr. Cecil Johnson, Chief Engineer, FISHER GOVERNOR COMPANY, Marshalltown, Ia.

*If it flows through pipe  
anywhere in the world  
chances are it's controlled by...*







## *Variety: the spice of life at American Oil*

*by Jim Koller*

"When I was first interviewed by American Oil representatives I was told I'd be given a free hand in guiding a wide variety of projects. This promise has certainly been kept!"

Jim Koller, 25 years old, came to American Oil right out of the University of Wisconsin where he earned his Bachelor of Science degree in Chemical Engineering. An Evans Scholar at Wisconsin, Jim describes his job at American Oil this way: "I work on basic chemical engineering problems, specializing in reactor design and process development problems. Before a process can go commercial, it must be tested in pilot plants. That's where I come in." Jim wants to stay in the technical research area, and plans to enroll in the Illinois Institute of Technology night school for courses in advanced mathematics.

The fact that many gifted and earnest young men like Jim Koller are finding challenging careers at American Oil could have special meaning for you. American Oil offers a wide range of new research opportunities for: Chemists—analytical, electrochemical, inorganic, physical, polymer, organic, and agricultural; Engineers—chemical, mechanical, metallurgical, and plastics; Masters in Business Administration with an engineering (preferably chemical) or science background; Mathematicians; Physicists.

For complete information about interesting careers in the Research and Development Department, write: D. G. Schroeter, American Oil Company, P.O. Box 431, Whiting, Indiana.

---

IN ADDITION TO FAR-REACHING PROGRAMS INVOLVING FUELS, LUBRICANTS AND PETROCHEMICALS, AMERICAN OIL AND ITS AFFILIATE, AMOCO CHEMICALS, ARE ENGAGED IN SUCH DIVERSIFIED RESEARCH AND DEVELOPMENT PROJECTS AS:

New and unusual polymers and plastics • Organic ions under electron impact • Radiation-induced reactions • Physicochemical nature of catalysts • Fuel cells • Novel separations by gas chromatography • Application of computers to complex technical problems • Synthesis and potential applications for aromatic acids • Combustion phenomena • Solid propellants for use with missiles • Design and economics: new uses for present products, new products, new processes • Corrosion mechanisms • Development of new types of surface coatings.



STANDARD OIL DIVISION  
AMERICAN OIL COMPANY

# *da Who? da Vinci*

by Bill Small

illustrated by Bill Steiner

*If there is one thing that a student engineering magazine doesn't need, it's another article on Leonardo da Vinci. But this is not just "another article" on good old da Vinci. It is the first article which exposes his true motivations and difficulties.*

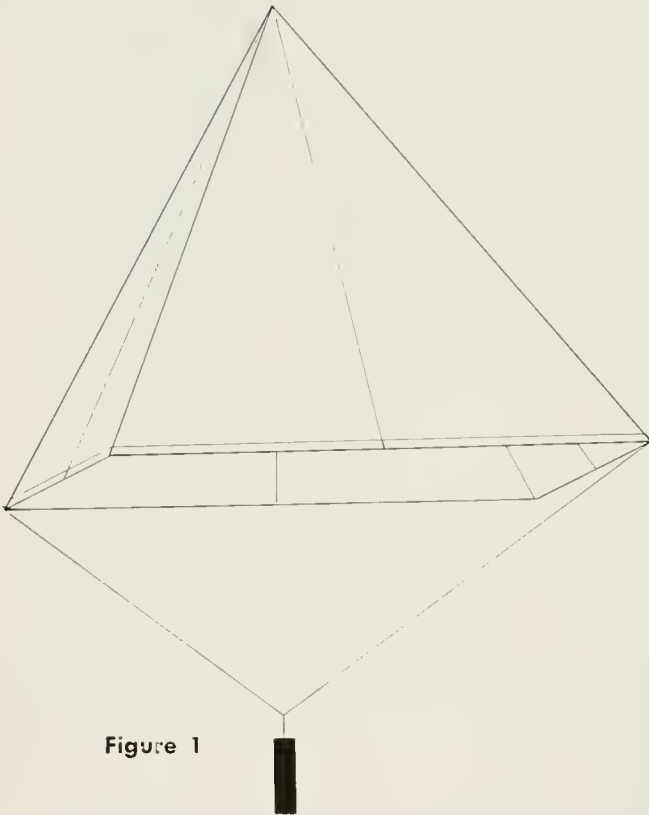

Figure 1



Figure 2



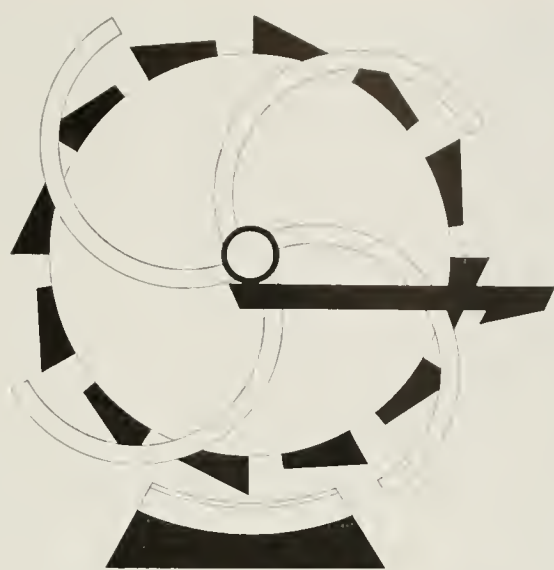
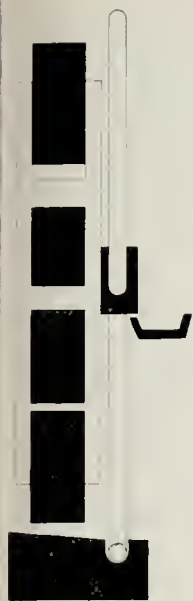

Figure 3

As you will find in any dictionary, if you are inclined to read books like that, Leonardo da Vinci was an Italian painter, sculptor, architect, scientist, musician, and natural philosopher. (He was not just an Italian painter, occasionally he would paint a Greek, a Spaniard, and sometimes, when he had nothing better to do, he would paint himself). But all this took a lot of work, and even though he had sixty-seven years in which to do it, he was pressed for time now and then. But he was not too handsome, so he wouldn't have had much social life even if he had not been so busy all the time. He did most of his painting in this youth, which is pretty remarkable when you remember that they did not even teach finger painting at da Vinci PS 206 where Lee went as just a runny-nosed little genius. In fact, he had done about all the painting he cared to do before he was even grown up.

When he did grow up, he decided to play with other kinds of toys, so he turned to science. One of the sciences he turned to was engineering, and was he surprised, because it was in even worse shape then than it is now. So he decided to think up some ideas which would not be appreciated by people of his day, since he read in a book somewhere that this was a sign of people who were ahead of their times. Here are a few of Leonardo's designs which he dreamed up all by himself in the same century that Columbus left Italy for Spain, where he figured he would have a better chance to get money to go yachting.

Figure 1 shows a parachute. I know it doesn't look like a parachute, but Lee

was not too good at sewing. Anyway, it was twelve yards square by twelve yards high. Lee was not a lot better at math than he was at sewing. The box represents a man; we tried to get the editor to pose for the picture, but he just mumbled something about the dean's approval and left. Leonardo did little to develop the idea any further since there weren't any more Vincians who needed a parachute after he invented it than there were before. Anyway, he wanted to think of an idea that was not full of air. He tried to invent something that would fly by a man's pushing pedals and moving his arms,

and the like, but he couldn't get the Italian Aeronautics Administration's approval on any of this stuff. Someone named Vittorio Tanny bought them all, picked them up, and went away mumbling something about fat Vincians.

Nearly every inventor tried to make a perpetual motion machine, so Lee thought he had better get started on one of those. Figure 3 shows his design for the machine; but I won't bother to explain it, because it didn't work anyway. Besides that, Lee figured even if he made one, he would not be around long enough to verify the outcome.

He soon began to design war equipment. There was a better market for it than for perpetual motion machines and he thought he'd give it a try. Figure 2 shows one of these ingenious devices. The horizontal bar was intended to knock the enemies' ladders off the wall, but every time he got a working model finished, his mistress would start hanging out laundry on it. So he gave that up too.

By this time, he was pretty mad because Edison hadn't been around yet, and he was spending an awful lot of money on candles to work all night by, with very little return. He took his anger out on his tools, and thumbs, while he invented another war machine. This one, Figure 4, was pushed from the center by two strong horses (or four weak ones). It had sharp blades on front that went round and round and round which were designed to literally shred the enemy to pieces. I think maybe he should have stuck to art. ♦♦♦

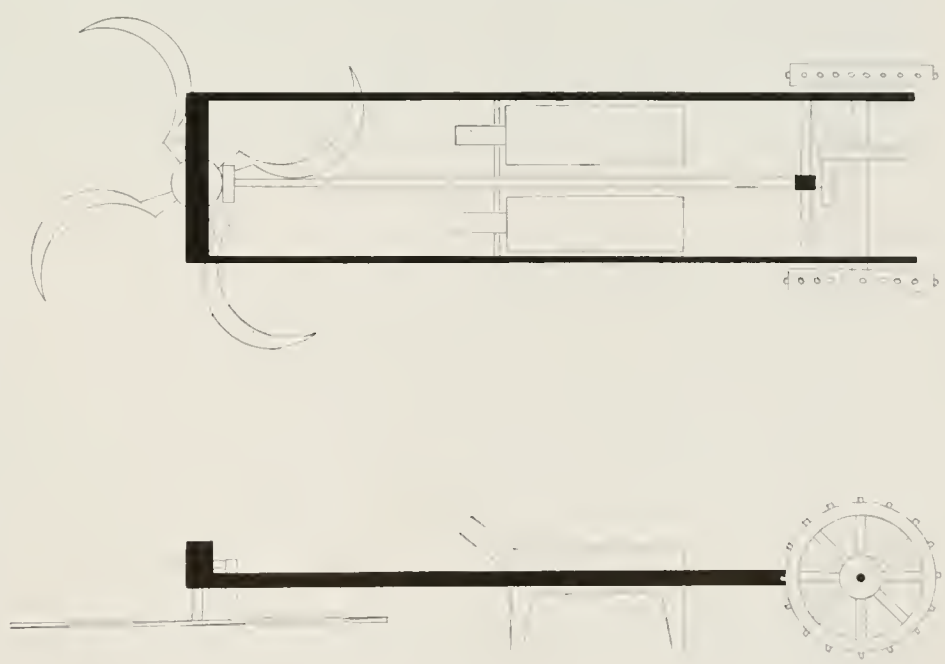

Figure 4



***Assignment:  
build a brake  
that will make  
its own  
adjustments***

**It's now a fact: every Ford-built car in '63 has self-adjusting brakes**

"Give us a brake," Ford Motor Company engineers were told, "that will automatically compensate for lining wear whenever an adjustment is needed—and make it work for the entire life of the lining."

Tough assignment—but not insurmountable. Today, not only does every Ford-built car boast self-adjusting brakes, but the design is so excellent that adjustments can be made more precisely than by hand.

This Ford-pioneered concept is not complex. Key to it is a simple mechanism which automatically maintains proper clearance between brake drum and lining.

Self-adjustment takes place when the brakes are applied while backing up. This adjustment normally occurs but once in several hundred miles of driving. The brake pedal stays up, providing full pedal reserve for braking.

Another assignment completed—and another example of how Ford Motor Company provides engineering leadership for the American Road.



**MOTOR COMPANY**

The American Road, Dearborn, Michigan

**PRODUCTS FOR THE AMERICAN ROAD • THE HOME  
THE FARM • INDUSTRY • AND THE AGE OF SPACE**





## 250,000 rpm / -452° F

*Miniature turboexpander permits major breakthrough in cryogenics . . .* Temperatures ranging from -200°F to -452°F are achieved by converting gases such as helium and nitrogen into a liquid state.

When cryogenic liquids circulate over an object, the moving molecules within come virtually to a stop. This abnormal condition makes some metals superconductive and extraordinarily sensitive to any form of electrical energy.

Military and commercial applications include increasing the effectiveness of ground and airborne detection, navigation and communication systems, shrinking the size of computers and solving specialized space cooling problems.

A leader in cryogenic cooling and lightweight turbomachinery, Garrett-AiResearch is now developing a closed cycle cryogenic system to compress and then expand (boil off) the low temperature gas into its supercold liquid state.

The tiny turbines within the system run on air bearings and eliminate all rubbing surfaces. Much greater system reliability and long life is the result . . . another major advance by Garrett in the exciting new science of cryogenics.

For information about other interesting projects and the many career opportunities with The Garrett Corporation, write to Mr. G. D. Bradley in Los Angeles.

Garrett is an "equal opportunity" employer.



THE GARRETT CORPORATION • AiResearch Manufacturing Divisions • Los Angeles 9, California • Phoenix, Arizona • other divisions and subsidiaries: Airsupply-Aero Engineering • AiResearch Aviation Service • Garrett Supply • Air Cruisers • AiResearch Industrial • Garrett Manufacturing Limited • Garrett International S. A. • Garrett (Japan) Limited

# Engineering Employment Opportunities

By Gary Daymon, EE. '64

Many words have been written and spoken concerning the seemingly asymptotic increase in the demand for engineers and scientists. According to the National Science Foundation, between 1953 and 1959 alone there were over 221,000 additional engineering jobs created. It has been estimated that by 1971 industry will need 45% more engineers than at the present time.

These facts and predictions are indeed very encouraging to the potential engineer. Only recently, however, has a systematic attempt been made to statistically analyze the demand for engineers and scientists. Deutsch and Shea, Inc. (advertising), of New York is now publishing a month by month Engineer/Scientist Demand Index (See Fig. 1), which promises an exact means of effectively following the demand for technical manpower.

The information provides current data on the volume of recruitment ad-

vertising in major newspapers and technical journals throughout the nation. The three major types of recruitment advertising represented by the index are: classified ads in newspapers, display ads in newspapers, and technical journal ads.

With a 1960 index of 100 it is possible to readily spot any significant changes in the technical manpower demands since 1960. Since ESDI has been in existence only two years, however, it is impossible to draw any long-range conclusions at the present time. Yet over a long period of time this monthly index could prove invaluable to government agencies, technical and scientific societies, and university placement offices as well as the potential engineer. With only a two year history ESDI has already revealed several apparent trends.

For instance, the yearly increase in the demand for engineers and scientists can be observed from the average 1960-

61 index of 92.9 as compared to the average 1961-62 index figures of 122.3! Obviously this 30.2 index difference is quite an encouraging improvement factor between the two years. From the January to July 1962 bulge in the index, the 1962 increase should be even more impressive thus leading to more enthusiastic predictions of the future demands for engineers.

The potential engineer should remember, of course, that these statistics include very little college recruiting efforts and apply largely to ads in large newspapers. As a result, many if not most ads are for experienced engineers. The potential engineer can benefit from the index, however, by obtaining a more accurate view of the future demands for engineers by observing past and current trends. Indeed, it is doubtful if any other profession experienced a thirty per cent increase in job opportunities last year. ♦♦♦

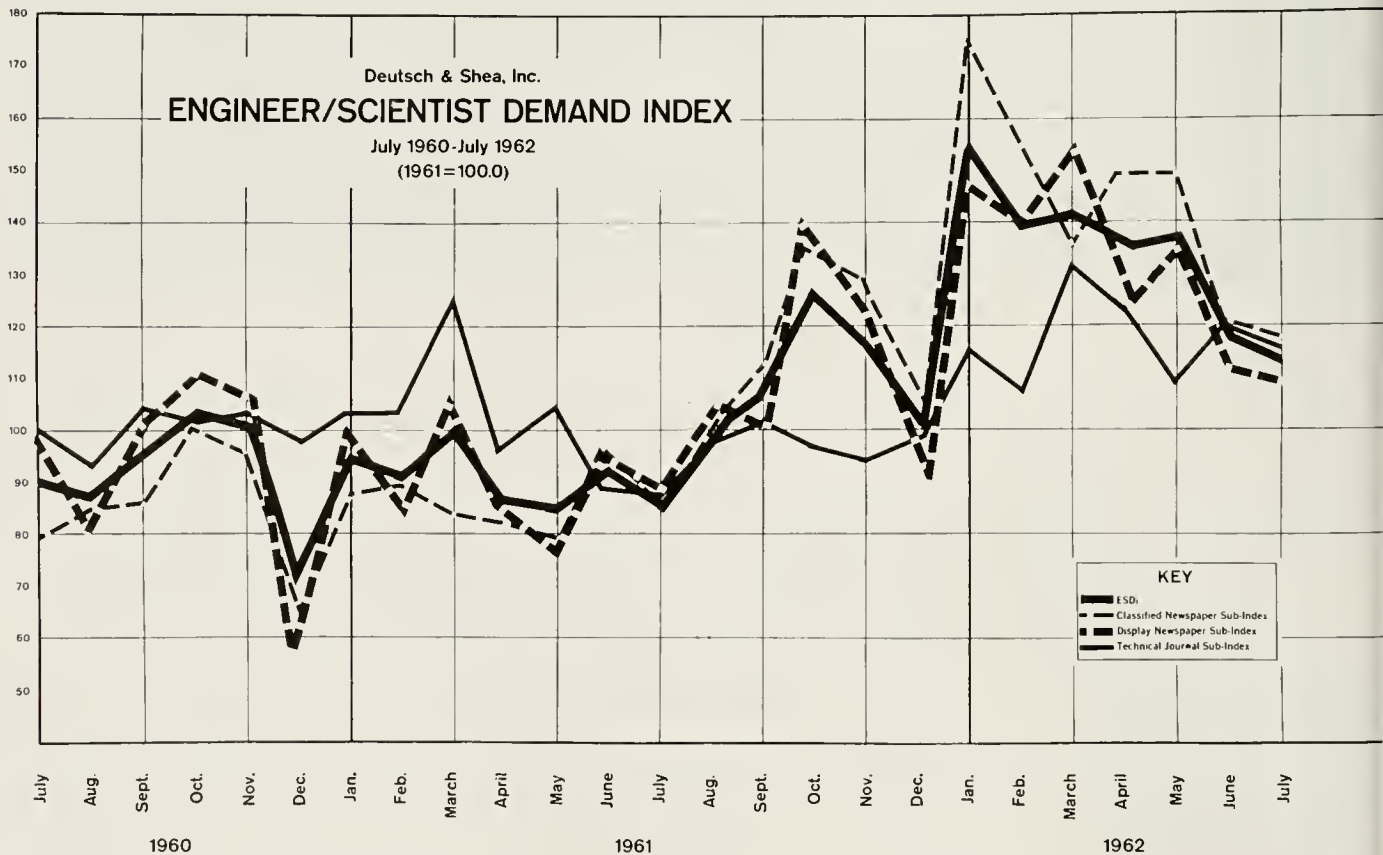



Advanced Systems Planning

Advanced Phased Array Antennas

Aerospace Systems Research

Airborne Instrumentation

Command & Control Systems

Communication Techniques Research

Computer Research

Data Processing & Display Systems

Digital Control Systems

Detection Systems

Electronic Countermeasures

Electronic Counter-Countermeasures

Ground Support Systems

Information Handling Systems

Intelligence Systems

Microwave Research

Microelectronics

Missile Guidance Systems

Navigation Techniques

Operations Research

Radio & Radar Research

Reconnaissance Systems

Receiver Design

Speech & Character Recognition Research

Solid State Devices

Satellite Tracking Systems

Simulator Systems

Systems Integration Techniques

Transistor Applications

UHF-VHF Circuit & Component Design

Electronic Engineers, Physicists,  
Mathematicians – BS, MS, PhD

## 30 ways to waylay opportunity at SYLVANIA ELECTRONIC SYSTEMS

R&D openings exist in all 30 areas detailed at the left. SYLVANIA ELECTRONIC SYSTEMS is a major division of Sylvania Electric Products Inc., a subsidiary of General Telephone & Electronics Corporation. The division has over-all responsibility for systems management of GT&E's major government projects, coordinating the broad defense systems capabilities of the various GT&E subsidiaries.

Within this rich mosaic of technical effort, any electronic engineer or scientist is practically certain to find an assignment which reflects his individual interests and provides a pathway for rapid professional growth.

Current openings are distributed over the 17 laboratories within the division. A talented man can concentrate on the field of his choice at one laboratory, or move freely anywhere within the complex as his career advances. He can become a technical specialist or develop the broad background required to enter large-scale systems engineering.

Sylvania Electronic Systems, established late in 1954, now has over 6,500 employees in six different operations (approximately 2,300 engineers and scientists). There are three main locations: Western Operation (suburban San Francisco), Central Operation (suburban Buffalo) and Eastern Operation (suburban Boston). Also near Boston are operations serving the entire division: Applied Research Laboratory; Product Support Organization; Systems Engineering and Management Operation.

For further information on specific assignments, contact your College Placement Office or write directly to Mr. D. W. Currier.



**SYLVANIA ELECTRONIC SYSTEMS**  
Government Systems Management  
for **GENERAL TELEPHONE & ELECTRONICS**



40 Sylvan Road – Waltham 54, Massachusetts  
U.S. Citizenship Required – An Equal Opportunity Employer

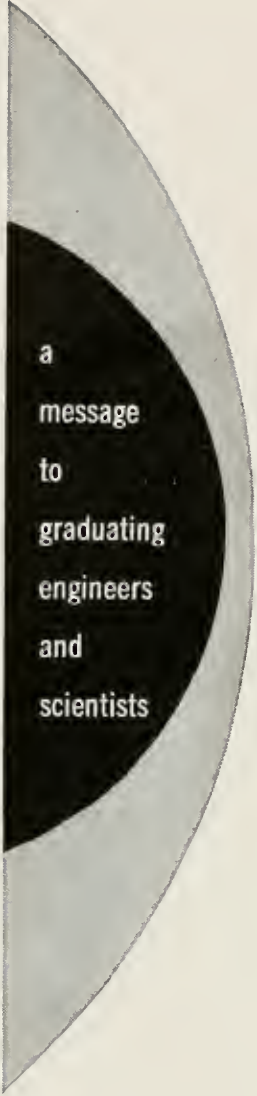

a  
message  
to  
graduating  
engineers  
and  
scientists

AT PRATT & WHITNEY AIRCRAFT...

**YOUR EYES CAN BE ON THE STAR**

**SPECIALISTS IN POWER . . . POWER FOR PROPULSION—POWER FOR AUXILIARY SYSTEMS.  
CURRENT UTILIZATIONS INCLUDE AIRCRAFT, MISSILES, SPACE VEHICLES, MARINE AND INDUSTRIAL APPLICATIONS**



## UT YOUR FEET MUST BE ON THE GROUND

The glamour and excitement of space age programs often obscure a fundamental fact. It is simply that farsightedness must be coupled with sound, practical, down-to-earth engineering if goals are to be attained. This is the philosophy upon which Pratt & Whitney Aircraft's position as a world leader in flight propulsion systems has been built.

Almost four decades of solid engineering achievement at Pratt & Whitney Aircraft can be credited to management's conviction that basic and applied research is essential to healthy progress. In addition to concentrated research and development efforts on advanced gas turbine and rocket engines, new and exciting effects are being explored in every field of aerospace, marine and industrial power application.

The challenge of the future is indicated by current programs. Presently Pratt & Whitney Aircraft is exploring the areas of technical knowledge in *magnetohydrodynamics . . . thermionic and thermoelectric conversions . . . hypersonic propulsion . . . fuel cells and nuclear power.*

If you have interests in common with us, if you look to the future but desire to take a down-to-earth approach to get there, investigate career opportunities at Pratt & Whitney Aircraft.

To help move tomorrow closer to today, we continually seek ambitious young engineers and scientists. Your degree? It can be a B.S., M.S. or Ph.D. in: **MECHANICAL • AERONAUTICAL • ELECTRICAL • CHEMICAL and NUCLEAR ENGINEERING • PHYSICS • CHEMISTRY • METALLURGY • CERAMICS • MATHEMATICS • ENGINEERING SCIENCE or APPLIED MECHANICS.** The field still broadens. The challenge grows greater. And a future of recognition and advancement may be here for you.

---

For further information regarding an engineering career at Pratt & Whitney Aircraft, consult your college placement officer or write to Mr. William L. Stoner, Engineering Department, Pratt & Whitney Aircraft, East Hartford 8, Connecticut.

---

**Pratt & Whitney Aircraft**

CONNECTICUT OPERATIONS EAST HARTFORD, CONNECTICUT

FLORIDA OPERATIONS WEST PALM BEACH, FLORIDA

**U**  
DIVISION OF UNITED AIRCRAFT CORP.  
**A**

An Equal Opportunity Employer

## Home Heating Research

Research on electrical heating for homes is being conducted at the University of Illinois this fall under the sponsorship of the Edison Electric Institute. It is being conducted by the University's Small Homes Council - Building Research Council, and the Department of Mechanical and Industrial Engineering.

The new project will include the evaluation of comfort provided by various types of electrical heating systems (including both radiant and convectional heating), various factors such as individual room controls, effects of ventilation and moisture, architectural and construction requirements, and installation methods.

This project should provide the public with an unbiased source of information concerning electrical heating, advance knowledge and practice in the field of home comfort, and provide the electrical industry with information valuable to the extension of electrical heating for homes.

The residence used in the investigation has eight miles of wire built into it to permit immediate determination of temperature at 472 locations throughout the structure. Weather data such as wind velocity, temperature, and hours of sunshine is also recorded.

The experimental house is being leased from the National Warm Air Heating and Air Conditioning Association whose research, meanwhile, will involve a study of filters and air cleaning devices to be made under controlled conditions in the university's engineering laboratories. Heating research which the Warm Air Association started at Illinois in 1918 has completely revolutionized the home heating industry.

The University of Illinois has become a world center of home heating and air conditioning study and information. As early as 1924 the Warm Air Association built at the University of Illinois the world's first house specifically designed to investigate heating under actual home conditions. Successive research houses have reflected new problems and changing public taste in homes. The house mentioned above is a typical split-level.

Boris W. Hrychewicz will be directly in charge of the new project, working under Prof. Rudard A. Jones, director of the Small Homes Council-Building Research Council, and Prof. Warren S. Harris, who heads all heating research in the Department of Mechanical and Industrial Engineering.

# NEWS

and

AT

# VIEWS

## Civil Engineering Faculty Honored

For the second year in a row the University of Illinois Civil Engineering Department has been recognized with multiple awards for its research work by the American Society of Civil Engineers. Two members of its staff, Prof. Ven T. Chow and Dr. William J. Hall, have been awarded research prizes. Last year, awards went to Profs. William H. Munse and Anestis S. Veletsos.

The Research Prize, consisting of a check for \$100 and a certificate, was established in 1946, with the first award being made in 1949. Research prizes are awarded to members of the Society for notable achievements in research related to civil engineering. Presentation of the awards to Chow and Hall will be made during the next meeting of the Society in February at Atlanta, Georgia.

Dr. Chow, a University of Illinois staff member since 1958, is Professor of Hydraulic Engineering and is presently directing the teaching and research programs in hydraulic engineering. He is one of nine faculty members recently appointed associate members of the University's Center for Advanced Study, which was established to encourage creative achievement and scholarship by providing recognition to scholars of the highest distinction. He was recommended for the Research Prize for "an outstanding contribution to the knowledge of flood protection and farm drainage." He is author of "Open-Channel Hydraulics," a well-known book in that field. He is also a consulting editor for Hydraulic Science and Engineering for the McGraw-Hill Book Co., Inc., and the editor of "Advances in Hydro Science" for Academic Press, Inc.

Dr. Hall, Professor of Civil Engineering and director of a number of research projects in brittle fracture mechanics at the University of Illinois, is cited for "outstanding contribution to knowledge in the field of the initiation, propagation and arrest of brittle fracture." Brittle fracture of steel structures has been a problem for many years, but it has received increased attention since world War II when a number of

steel ships failed. Brittle fracture failure, characterized by a lack of ductility and energy absorption, usually occurs without warning and is often catastrophic.

The object of the research is to find out why and when steel may become subject to brittle fracture and to provide the designer with methods of avoiding such conditions. Major research work, much of which has been carried out at the University of Illinois, has contributed to improved design practices. Recent research carried out by Dr. Hall and his colleagues includes studies of fracture propagation in wide steel plates, studies of fracture initiation as affected by different welding procedures, and application of research findings to design.

## Fallout Proof Homes?

Protection against nuclear warfare may be built into American homes if architects and engineers follow ideas being developed at the University of Illinois.

The U. S. Office of Civilian Defense has approved a \$20,000 contract with the University of Illinois' Small Homes Council-Building Research Council for preparation of a 32 page manual on making residential construction more resistant to the effects of nuclear attack.

Possibilities are being considered for making the shelter area a regularly-functioning part of the home. Factors being studied are the advantages of strengthening joints and other areas in frame construction and reinforcement of masonry construction. The heat reflecting factors of paints, exterior surfaces and roofing materials are also being considered.

Brian Crumlish, Woodstock, Ill., Architect, has been employed full time on the project under Prof. Rudard A. Jones, SHC-BRC director. The University of Illinois' Department of Civil Engineering which has been a leader in studying effects of blast and heat from nuclear explosions and protection against these and against radiation is also supplying vital information for the manual.



# UNIVERSITY

THE

of

# ILLINOIS

Edited by Gary Daymon

## C.E. Student Receives Design Award

Larry D. Stroup, a senior in Civil Engineering at the University of Illinois, has received a \$50 sixth place award in the annual James F. Lincoln Arc Welding Foundation design award program for engineering undergraduates.

Fifty-five undergraduates in 22 universities and colleges throughout the United States shared \$10,000 in awards in the 14th annual engineering undergraduate program sponsored by the foundation. The competition was initiated to stimulate interest in scientific study and research to advance the design of arc welded machines and structures.

Larry's entry was "Design of a Portable Sawmill." He conceived the idea of bringing the sawmill to the timber after observing the labor and cost involved for Southern Illinois farmers to haul logs to stationary sawmills. The first mill from Stroup's plans was built by John Phillips of Walnut Hill, five miles from Stroup's home town of Dixon, Illinois.

## New Communications Computer

The University of Illinois' giant Wullenweber radio direction finder is being teamed with a new \$428,098 electronic computer for enlarged research on the ionosphere. This study of the radio-reflective layer some 100 miles above the earth's surface is the newest step in various U. of I. projects to investigate long distance radio communications.

The three year old direction-finder is the largest in the world and is accurate to one-quarter of a degree. It has noted such unusual effects as signals from Washington, D.C., arriving from the north instead of the east. Such vagaries reveal information about the ionosphere just as reflected light may reveal information about an irregular mirror.

Current research facilities are being augmented by a high-frequency transmitting station in Lubbock, Texas, 800 miles southwest of the U. of I., and a receiving station in Ottawa, Canada, 800 miles northeast. Signals beamed from Texas and reflected to Canada by the ionosphere over the U. of I. cam-

pus will provide information from directly above the direction-finder.

Data at the three points will be automatically recorded and synchronized within one ten-thousandth of a second for analysis by the new Bendix computer. The computer will be housed near the direction-finder, located a few miles west of the Urbana-Champaign campus.

The project is being carried out by the U. of I. department of electrical engineering under Prof. Edgar C. Hayden and Prof. Albert D. Bailey, with Prof. Robert S. Smith in charge of computer and information handling. The U. S. Office of Naval Research and the Navy's Bureau of Ships are financing the project.

## Cheaper Highway Construction

Thousands of dollars may be saved in highway construction through a bulletin being published by the University of Illinois' Engineering Experiment Station. It represents a method for more accurately calculating the quantity of water which must be handled by a culvert. This information is essential to properly size the many small drains which, as part of the nation's highway construction, cost a billion dollars a year.

Present calculations are based on a 75-year old formula which allows wide margin for individual estimate. This results in unnecessarily expensive and oversized or inefficient and undersized construction.

The new method was developed by Prof. Ven Ten Chow, University of Illinois Department of Civil Engineering, in research sponsored by the Illinois Division of Highways and the United States Bureau of Public Roads. It is based on the knowledge of how fast rain runs off various types of soils and other surfaces. Charts of current hydrological information form precise data with which the practicing engineer can plan construction. The design is based on the heaviest rainfall expected under normal conditions rather than the abnormal heavy storm which may

occur only once in a century. (Field studies are now being made to verify factors involved.)

Prof. Chow's bulletin "Hydrological Determination of Waterway Areas for the Design of Drainage Structures in Small Drainage Basins" presents the new method and its background. Copies are \$1.50 from University of Illinois Engineering experiment Station.

## U. of I. Receives Three NSF Grants

Three National Science Foundation research grants totaling \$324,680 have been made to the University of Illinois.

The first grant of \$195,980 will support a series of films for training ninth grade algebra teachers. The series will be under the direction of Max Beberman, director of the University of Illinois' Committee on High School Mathematics. This grant will permit revising and extending the University of Illinois' mathematics film project from its present 20 sound films towards a goal of 49, including three or four sub-series of films. Complete sequences of filmed classroom instruction, with Prof. Beberman and other mathematics authorities as teachers, have been nationally acclaimed and are in constant use in the UICSM project teacher training program throughout the country.

The second grant of \$73,900 is for continuation of research titled "Alloys of Transition Elements." The research will be under the direction of Paul A. Beck, Department of Mining, Metallurgy, and Petroleum Engineering. The grant will further the investigation of metals with incomplete electronic structure, particularly those with "d-band deficiency." Research will include formulation of theoretical models of certain transition elements, carrying out of calculation based upon the models, and testing of the models by comparing calculated properties with experimental data.

The third grant was a chemistry grant of \$54,800 for support of research entitled "Electron - Deficient Compounds." Theodore L. Brown, Department of Chemistry and Chemical Engineering, will be in charge of the research. It will involve reactive substances that decompose readily in air or water, and that require handling in an atmosphere of inert, dry gases. Study of electron-deficient lithium, boron compounds, as well as tri-methyl-aluminum, which have higher ratios of bonding components to electrons than are usually found, will be extended under the grant. The emphasis will be on the study of lithium compounds. ♦♦♦



# Engineering Alumni Convention

By Art Becker, EE. '66

Engineering is a booming profession. Its exploding breadth and variety pose formidable obstacles to counselors and administrators in their attempt to define, explain, and present it as the approachable and attractive career that it is.

The Engineering Alumni Committee of the College of Engineering at the University of Illinois was formed with this realization in mind. As more young persons attend college and seek careers requiring professional education, career counseling has been receiving increased attention. The nation's educators and industrialists have recognized the importance of such counseling, but with the wide variety of careers now opened to the college-educated person, the counselor's work is becoming continually more complex and difficult. The Engineering Alumni Committee is devoted to assisting high school counselors in one phase of this task by attempting to present students with an accurate, up-to-date picture of engineering as a career.

The Committee is a relatively young organization, founded with the aid of Illinois' Dean Everitt in 1950, and its establishing principle has not been altered: that high school students with abilities and interests leading to satisfaction and success in engineering would understand the opportunities, challenges, and rewards of the profession. Recruiting an army of new engineers is not the purpose of the Committee; quality, rather than quantity, is stressed. The Committee's concern is the growing engineering manpower shortage and its implications for national survival; it is involved in placing engineering in an accurate proportion with other fields, so that students recognize the profession for what it is, and do not mistakenly choose one career when their interest lies in another.

Past programs pursued by the Committee include discussions on college entrance requirements, teaching machines, and high school physics and math courses. The annual fall convention of the Committee is the highlight of each year's activity where members are addressed by teachers and practicing engineers and may view instructional films or take part in panel discussions dealing with new thoughts on engineering counseling. Participants in the work carried on by the Alumni Committee are chosen by the existing Committee members; they may be asked to attend, or may apply for acceptance.

The Committee this year, on October 26th and 27th, treated its guests to an engaging and thought-provoking timetable of events. Dean Everitt opened the first day's program with an address on the problems of high school counseling. A panel discussion on the image of engineering followed, moderated by Dean Opperman and conducted by high school counselors. The second day's discussion turned to more specific topics. Deans Pierce and Price (Chicago Undergraduate Division) spoke on current trends in enrollment, and a report on the highly-regarded JETS (Junior Engineering and Technical Societies) was delivered by that organization's State Director, David Reyes-Guerra. But the ladies stole the show—excellent talks on the place of women in engineering were delivered by the Miss Kathy Miller, U. of I. co-ed in Metallurgical Engineering, and Miss Betty Lou Bailey, a highly successful engineer from General Electric's Valley Forge Space Technology Center.

The dominant theme of the convention was, in fact, the role played by women in engineering. Dean Opperman's remarks dealt with increasing op-

portunities and increasing salaries engineers can expect to find in their field. But while the profession grows more satisfying and challenging each year, interest among high school students is not sufficient to the demand. A more intense program of counseling is needed. Students seem to misunderstand the field simply from lack of contact with practicing engineers. It is no problem to discuss liberal arts, education, or agriculture with a graduate of one of these colleges, but engineers are rarely found on high school staffs. Adequate counseling for the engineering profession is the only remedy. One area in which it currently fails is in dealing with interested girls. Questionnaires sent by Dean Opperman to co-ed students of engineering revealed that their high school counselors "did everything to discourage" their interest.

Miss Betty Lou Bailey, however, refused to be discouraged, even when she found herself the lone woman in a graduating class of 700 engineers. Her degree in Mechanical Engineering was won in 1950, and she has since held a great variety of engineering responsibilities at General Electric. One of her outstanding credits is a patent on the design of an exhaust nozzle for the J-93 engine.

Miss Bailey announces she does not play at campaigning for female supremacy, but does wholeheartedly encourage more of her sex to take advantage of engineering's inviting opportunities. She admits that some firms just will not hire women engineers, but surveys do show that over 65% will. Counselors should recognize the openings and promote interest among girls. The weaker sex is able to handle the job—after all, a construction engineer's task is to direct, not to wield, a sledge hammer. ♦♦♦





## Reflections of Telstar

Remember the picture above? It flashed across your television screen on a hot night last July. Perhaps you remember that it originated from France. And that it reached the U.S. via Telstar, the world's first private enterprise communications satellite.

Since that summer night, the Bell System's Telstar has relayed electronic signals of many types—television broadcasts, telephone calls, news photographs, and others.

But there's one Telstar reflection you might have missed. Look into the faces of the Bell System people below and you'll see it. It is the reflection of Telstar's

success that glowed brightly on the faces of all who shared in the project.

Their engineering, administrative and operations skills created Telstar and are bringing its benefits down out of the clouds to your living room.

These Bell System people, through their talented, dedicated efforts, make your phone service still better, more economical, and more useful.

The reflections of Telstar are many.



**Bell Telephone Companies**



Technocutie . . .

## *Marcie Walters*



TECH's star photographers proved themselves to be excellent judges of beauty when they chose Miss Marcie Walters as this month's TECHNOCUTIE. Shortly after they photographed Marcie, she was chosen Queen of the Dolphin Water Show. Marcie has also been Miss Decatur and a finalist in last year's Illio and Dolphin beauty contests. Miss Walters, a cheerleader (in more ways than one), is a LAS sophomore from Forsythe, Ill., and a member of Alpha Chi Omega sorority. She enjoys drama, speech, bowling, sewing, and piano.





Ambitious, talented young men with new ideas and a zest for challenge will find unusual opportunity at Delco Radio Division, General Motors Corporation.

Delco enjoys an enviable reputation for attracting and retaining top-notch talent in the electronics field. We feel it's a result of the atmosphere at Delco where the individual finds opportunity to exercise and develop his abilities to the fullest.

# OPPORTUNITY is yours at DELCO

solid state electronics ●



Our recently completed 125,000 sq. ft. Research and Development Center provides unlimited facilities for utilizing these abilities in the investigation and development of such space age devices as semi-conductors, computers, static inverters, thermoelectric generators, power supplies, machine controls, to name but a few of Delco's current projects.

To this combination of outstanding talent and facilities we attribute our pattern of success over the years. To this same combination we look for continued success as we assault the challenges of the future.

Why not cast your lot with a leader in the field? Arrange an appointment with our interviewer when he visits your campus, or for additional information write: Mr. C. D. Longshore, Supervisor  
—Salaried Employment.



DELCO RADIO DIVISION OF GENERAL MOTORS

KOKOMO, INDIANA

*An equal opportunity employer*



# Skimming Industrial Headlines

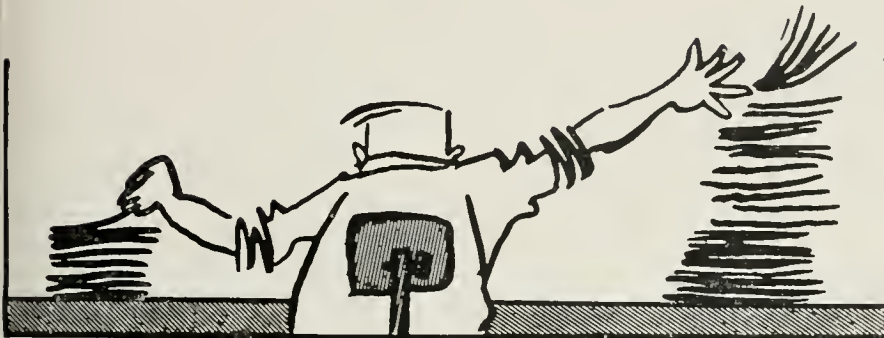

Edited by Art Becker, EE. '63

## Thermoelectric Refrigerator

Soon the world's first thermoelectric refrigerator will be sold commercially by Norge dealers. It contains no moving parts, compressor, or refrigerant fluid. Instead, a direct current passing through a junction of dissimilar metals will produce the cooling effect. The unit provides two cubic feet of food storage.

## Visible Light Laser

The Perkin-Elmer Corporation and Spectra-Physics, Inc., of Mountainview, California, have announced the production of the first visible-light continuous wave laser for the commercial market. Developed jointly by the two companies, it will be marketed by Perkin-Elmer. The unit is a helium-neon gas phase laser which emits a continuous bright red beam of coherent visible light at a wavelength of 6328 angstroms.

## Microwave Cooking

The same microwaves that are used to send radar messages and television pictures can now cook a complete meal in 90 seconds or 40 complete meals in one hour. A magetron produces the 2450 megacycle waves which cook the food in a cool, tightly-sealed oven. Only the food is heated.

## Microminiature Counter Tube

EON Corporation has developed an ultra-tiny counter tube which can be implanted directly into blood vessels, body cavities, or solid tissues without causing tissue damage. With a number of such counters connected to data-recording equipment, hospital research teams can monitor the uptake or excretion of radioactive tracer compounds.

## Wireless Portable TV Camera

A wireless TV camera weighing 20 pounds with its 40 pound companion back-pack was used for the first time during the CBS TV coverage of Scott Carpenter's orbital space flight in "Aurora 7." The Japanese-built camera uses a standard 7" image orthicon camera tube that can be fitted with a zoom or any other standard lens. The back-pack consists of a complete microwave relay transmitter and a rechargeable battery. The two units can be separated by as much as 1500 feet and still produce broadcast quality pictures.

## New Outlet For Antifreeze

Supermarkets and discount houses are becoming big outlets for antifreeze due to a rise in do-it-yourself mechanics. About half the antifreeze put in car radiators each year is done at home.

## For The Office That Has Everything

The water-cooler gang in almost any office should welcome the latest cooler. The device is the same size and shape as ordinary coolers, yet besides cold water, it dispenses hot water for making coffee and has a refrigerator-and-ice-cube compartment for storing drinks and food.

## Fruit Floats Into Cans

Cherries at a West Coast plant are going upstream to be canned, reports Factory, McGraw-Hill publication. The plant found that using water to float fruit up a grading table and down into cans is less bruising than using conventional conveyor belts.

## Slip-On Car Chains

Tire chains now are on the market that the manufacture claims can be put on in less than a minute per wheel.

No jacking or moving is needed to put on the chains. Bent-wire handles make it easy to slip the chain up and over and in back of the tire, the company says.

## The High-Priced Spread

Scientists recently learned that the Pillar of Delphi, a wrought-iron column about 24-feet high in India, had withstood the ravages of corrosion for 1600 years—thanks to butter. In ancient times, Indians anointed the pillar with butter at religious festivals. Can Blue Bonnet match that? ♦♦♦

## Ultrasonic Water Meter

Scientists in Rhode Island have developed a device that measures the velocity of rivers with ultrasonic sound waves. The device sends waves down and across the river to a receiving apparatus which is so sensitive it can measure the extra speed added to the waves by the river flow.

## Keeping Cool Cool

Dry ice is being used to keep coal cool enough to prevent spontaneous combustion. Pipes perforated and filled with dry ice are hammered into piles of coal. This not only decreases the temperature, but also spreads a blanket of carbon dioxide which smothers a fire.

## Automatic Tire Pressure

A car and truck supply firm has developed a system that automatically corrects tire inflation according to all changing vehicle and road conditions while the vehicle is in motion. Should a leak develop, the system pumps air to the tire until repairs can be made.

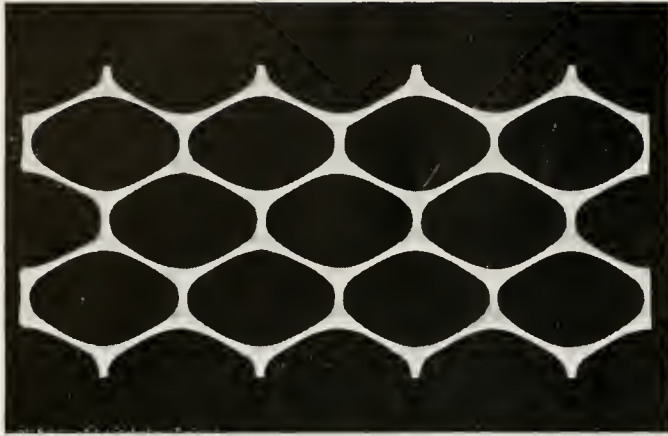

**Pencil-Thin Treillage** must be made of a metal that flows evenly and fully into every part of intricate molds. It must also resist corrosion and be able to absorb hard blows without breaking. Because Malleable iron has all these requisites, it is used for highest quality treillage in traditional and contemporary designs.



**Two And One Half Foot Long Gear Racks** for boat trailers look like costly machined bars. These racks are now Malleable iron castings, and are used without any finish machining. A concave impression running along the entire length underneath closely fits the pipe to which it is welded.

# Which Would You Design As Malleable Castings?

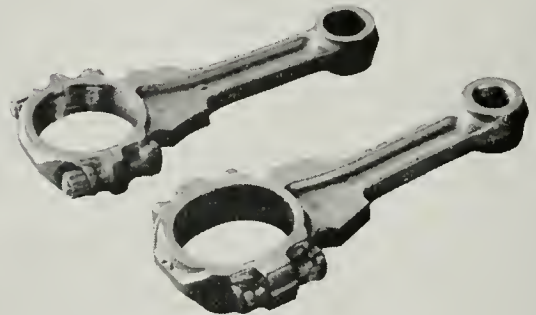

**Automotive Engine Connecting Rods** are prime examples of highly stressed parts. Alternating tension and compression for millions of cycles demands high fatigue strength. Modern design, testing and production techniques have been combined to produce pearlitic Malleable connecting rods of superlative quality that are now being used in American cars.

Send for this 16 page "Malleable Engineering Data File." You will find this informative brochure is an excellent reference piece.

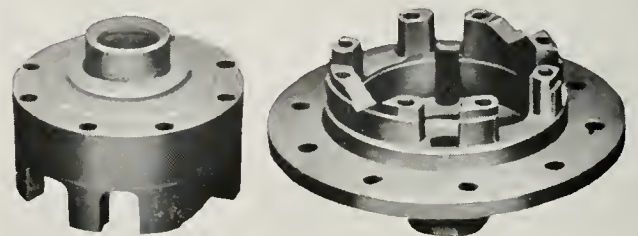
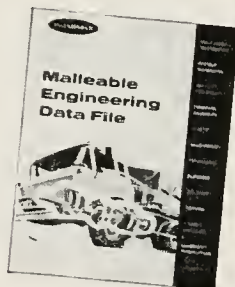

**Limited-Slip Axle Differential Components** of the design shown require high strength, hardenability and close tolerances. Expensive machining is eliminated by creating complicated interior details with shell molding. The use of pearlitic Malleable provides the desired combination of material and process for economical and reliable parts.



Malleable Founders Society, Union Commerce Building, Cleveland 14, Ohio



ELECTRONICS  
ENGINEERS  
& PHYSICISTS:

# If space is your future, your career is with Hughes

IN ASTROSPACE  
IN AEROSPACE  
IN TERRASPACE  
IN HYDROSPACE

As far back as 1890, Jules Verne visualized excursion trains to the moon. Today — 72 years later — Hughes offers you the opportunity to play an important part in man's actual conquest of space.

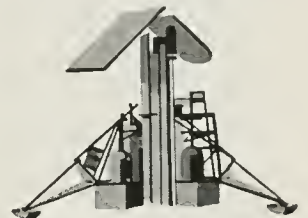

Help us soft-land the SURVEYOR on the moon — or work with us on exciting advanced projects such as:

**ANTI-MISSILE DEFENSE**  
**SYNCOM (Communications satellite)**  
**PLASMA PHYSICS & ION PROPULSION**  
**ADVANCED FIXED-ARRAY RADAR SYSTEMS**  
**LASER & MASER RESEARCH & DEVELOPMENT**  
**NUCLEONICS & MOBOT\* SYSTEMS**  
**SOLID STATE MATERIALS & DEVICES**  
**DATA PROCESSING & COMMAND-CONTROL**

**B.S., M.S. and Ph.D. Candidates**  
Members of our staff will conduct

## CAMPUS INTERVIEWS

**November 6 and 7, 1962**

Find out more about the wide range of activities, educational programs and relocation allowances offered by Hughes. For interview appointment or informational literature consult your College Placement Director. Or write: College Placement Office, Hughes, P.O. Box 90515, Los Angeles 9, Cal.

Creating a new world with ELECTRONICS

# HUGHES

HUGHES AIRCRAFT COMPANY  
An equal opportunity employer.

\*Trademark Hughes Aircraft Company

Bettman Archive







## Wankel Engine

(Continued from page 10)

\*Sealing. The apex seals, by centrifugal force, must remain in continuous contact with the bore. Since the rotor not only has a planetary movement around the output shaft center but also turns around its own center, there is a dual rotation which continuously varies the speed of the apex seals. (On one of the engines currently being tested, the seal velocity ranges from 1,752 ft./min. to 4,020 ft. min. with an average pressure of 10 atmospheres.) As a result, these seals are subjected to inward and outward alternating radial accelerations, and the forces due to these accelerations must be added to or subtracted from the centrifugal force intended to keep them in continuous contact with the bore. Of course, this phenomenon is not peculiar to the N. S. U. Wankel engine but is characteristic of any vane type blower or pump. It is, however, a potential source of trouble.

N. S. U. engineers have already settled on solutions to some of these and other problems. For example, the single rotor engine is inherently out of balance. Although the rotor itself is balanced about its own center, this center is at the center of eccentricity of the output shaft. The forces created by these out of balance masses have been fully balanced by attaching compensating masses to the output shaft on each side of the rotor. However, due to the cooling oil pulsating through the rotor, those masses produce another problem unless the cooling passages within the rotor are always full of oil. This oil should be under high pressure to prevent aeration, but since this is difficult to maintain at high speeds, a medium of low pressure is used throughout.

Engineers devoted considerable effort to minimizing power losses due to inefficient rotor cooling. The planetary movement of the rotor, in an orbit about the output shaft, complicated the cooling problem. In fact, it was found that several bhp were absorbed by the purely parasitic churning of the oil in the rotor. The solution was to inject the coolant into the rotor through a hollow output shaft and extract it using stationary guide vanes to give the oil centripetal velocity towards the return passage. The vanes are surrounded by a sheet metal face sealing ring which is now fitted rather loosely, having previously had a tendency to distort from heat, causing failure to seal effectively.

Another major problem was the quality of the rotor bearing which operates under multiple forces. Primarily, it must be capable of withstanding the fluctuating combustion impulses together with

the centrifugal forces created by the cooling fluid within the rotor. The bearing loads are not great enough to preclude the use of ordinary bearings. They have been tested and, at present, multi-row caged roller bearings are favored and will be used until more knowledge of characteristic engine behavior is accumulated.

Most of the N. S. U. Wankel engine's advantages stem from its rotary action which eliminates much of the noise, vibration, and wear resulting from the complex interactions of reciprocating engines. Reciprocating pistons must be brought to a complete stop at the end of each stroke and then must be accelerated in the opposite direction. The resulting inertia losses increase in proportion to the square of the engine's speed, preventing efficient operation at high rpm. Rotating parts, on the other hand, do not stop and reverse, allowing efficient operation at high speeds. The prototype was capable of 17,000 rpm indicating that the rotary engine is a promising alternative in attempts to achieve high power from small, light engines. ♦♦♦

## Like to Deal with the Abstract?

For the engineer who wishes to be well read but lacks the time, *Engineering Departmental Reports and Theses 1961* may be an answer. This publication, Engineering Experiment Station Circular 73, contains abstracts and bibliographic material for reports published departmentally in the University of Illinois College of Engineering during the period July 1, 1960, to June 1, 1961. Titles, authors, and advisors are presented for master's theses and doctoral dissertations.

Circular 73 is available free of charge from Engineering Publications, University of Illinois, Urbana.

—Outlook

## New Lead for Old

Lead can be salvaged 99.75 per cent pure from automobile storage batteries by means of a new Hungarian process. The key to the new process is the addition of sodium hydroxide and sodium sulfide during a two-step refining smelt operation.

## Bonuses In Stamps

Wives and children of employees in a Louisiana plant are pushing Dad to work harder. The company gives away green stamps to workers who increase productivity, save material or boost sales.

## ★ COLUMN CHUCKELS ★

Statistics show that Vassar graduates have 1.7 children, while Yale graduates have 1.4 children on the average. This proves that women have more children than men.

\* \* \*

Two men were flying east in a plane, making the first air trip of their lives. The plane touched down at St. Louis, and a little red truck sped out to its side to refuel it. The plane landed again in Cleveland and again the little red truck dashed out to it. The third stop was Albany and the same thing happened.

The first of the two men looked at his watch and turned to his companion. "This plane," he said, "sure makes wonderful time."

"Yep," said the other, "and that little red truck ain't doing so bad either."

\* \* \*

A Texan, newly arrived in England, was playing poker with a couple of the natives. He was pleasantly surprised upon picking up an early hand to see four aces in it.

"I'll wager a pound," said the Britisher on his right.

"Ah don't know how y'all measure your money," drawled the Texan, "but ah reckon ah'll have to raise you about a ton."

\* \* \*

A sweet old lady, always eager to help the needy, spied a particularly sad-looking old man standing on a street corner. She walked over to him, pressed a dollar into his hand and said, "Chin up."

The next day, on the same corner, the sad old man shuffled up to the lady and slipped ten dollars into her hand.

"Nice picking," he said in a low voice. "He paid nine to one."

\* \* \*

A lobbyist who was opposing any large appropriation for a state college approached a legislator who boasted of his self-education.

"Do you realize," asked the portly lobbyist gravely, "that up at the state college men and women students have to use the same curriculum?"

The legislator looked startled.

"And the boys and girls often matriculate together?"

"No!"

The lobbyist came closer and whispered, "And a young lady student can be forced at any time to show a male professor her thesis?"

The legislator shrank back in horror.

"I won't vote 'em a damn cent!"

♦♦♦

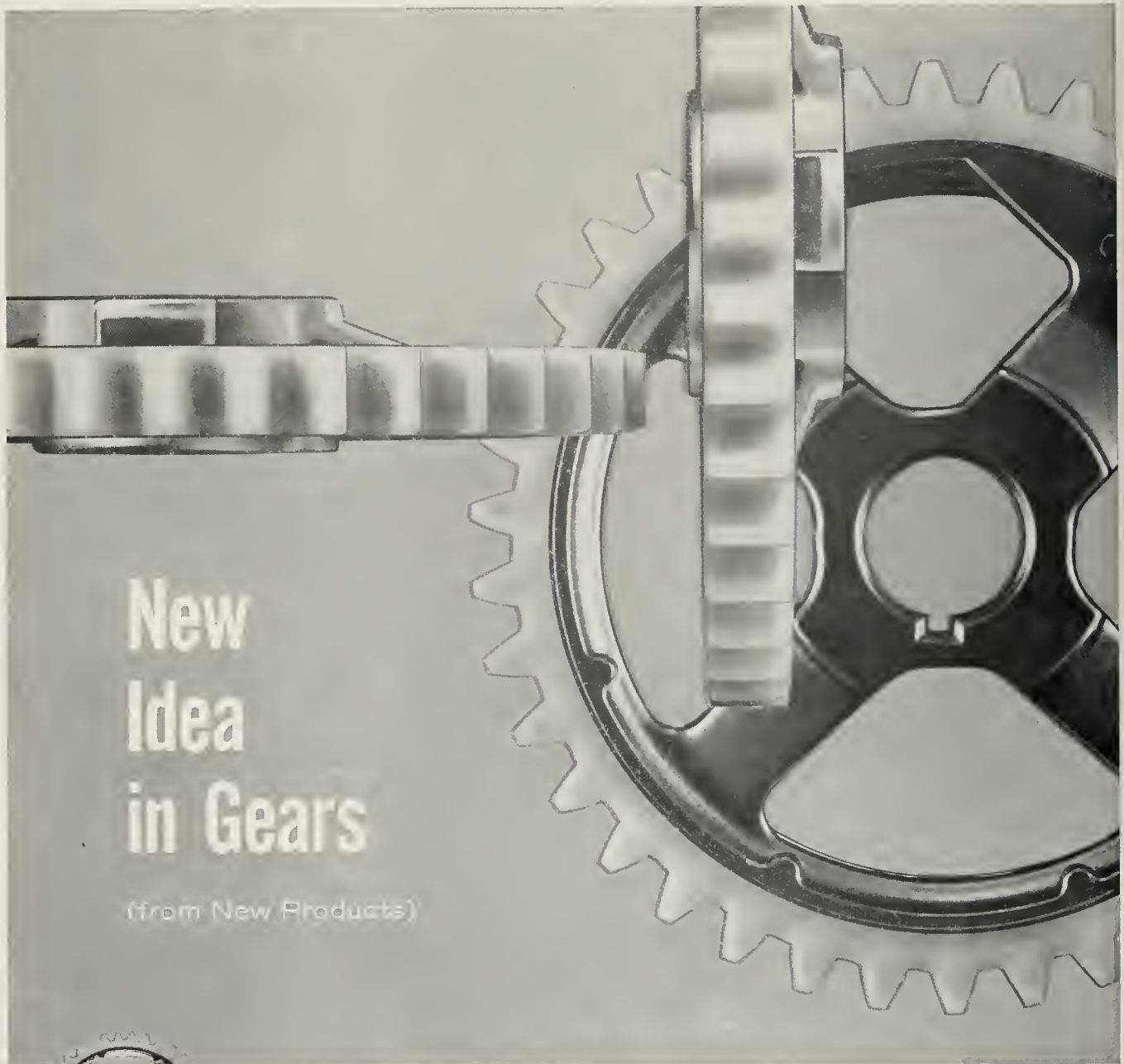

# New Idea in Gears

(from New Products)



The story of this new type of timing gear illustrates why the die casting industry is one of the most challenging a young engineer can enter. Notice that the center of the gear is a metal die casting, while the teeth are of east nylon, bonded to the metal center. The result is a gear of tremendous tooth strength, which runs quieter and wears longer than conventional gears. This one took a lot of thinking, engineering and experimentation to work out, but it's worth the effort to us . . . and to our customers. If such creative development thinking appeals to you, consider the die casting industry as you formulate career plans. We would be pleased to have you submit your resume at any time.

## NEW PRODUCTS CORPORATION

BENTON HARBOR, MICHIGAN





**X-15**—the famed research rocket plane that has reached speeds over 4000 mph and altitudes of 314,000 ft. Re-entering the atmosphere on the way back home, friction can make it glow like a red hot

poker. The intense heat on the surface of the ship would soften and weaken materials normally used in aircraft construction. What kind of metal can be counted on to stay strong at the red

heat of re-entry? Engineers found the answer to this difficult problem in a Nickel-containing alloy strong enough to resist sizzling temperatures of 1000 degrees, and more.

## How Inco Nickel helps engineers make new designs possible and practical

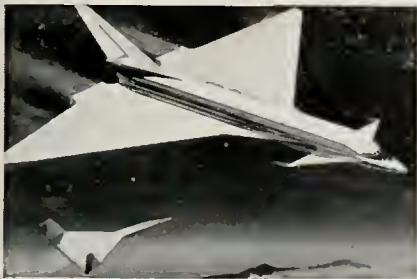

**2000 mph airliner**—a supersonic jet that will fly from New York to London in just over 2 hours at speeds of 2000 mph, and at 70,000 ft. altitudes. What will hold her skin together? Logical choice: a brazing alloy containing palladium (one of the 14 elements produced by International Nickel), providing great strength at high temperatures—up to 630° F—caused by supersonic speeds.



**Moon crawler.** Sometime during 1964, this spider-like object—the “Surveyor”—is expected to land on the moon’s surface and transmit information to earth on what the moon looks like and what it is made of. What metal will this machine need to withstand the extreme cold? Most likely a Nickel-containing alloy to provide toughness at sub-zero temperatures.

Today’s engineer is aware of the advantages of Nickel-containing metals. He knows that Nickel, or one of its alloys, can make hundreds of new designs — from the strong, heat-resistant skin of a research rocket plane, to the complex parts of a moon surveyor—perform better and last longer.

You’ll find Inco’s List “A” helpful and informative. It has descriptions of 200 publications, covering applications and properties of Nickel and its alloys. Write: Educational Services,

The International Nickel Company, Inc.  
67 Wall Street, New York 5, N. Y.



## INTERNATIONAL NICKEL

The International Nickel Company, Inc., is the United States affiliate of The International Nickel Company of Canada, Limited —producer of Inco Nickel, Copper, Cobalt, Iron Ore, Tellurium, Selenium, Sulfur and Platinum, Palladium and other Precious Metals.



# BOUNDLESS

OPPORTUNITIES in space research  
OPPORTUNITIES for career development

No matter what degree or academic level you have attained, NASA offers the graduate engineer or scientist unparalleled opportunity for continued professional growth.

At NASA, you'll play a significant role in answering modern mankind's greatest challenge—the conquest of space. You'll participate in history-making projects and work with eminent professional people.

NASA offers outstanding work-related graduate study programs. While on full salary, you can take graduate courses for credit during working hours at a nearby university, with tuition paid. Seminars conducted by world-famous scientists and engineers are frequently held.

NASA offers you a wide choice of work areas, unequaled facilities, and outstanding opportunities for professional achievement and advancement.

Should this environment interest you, write the Personnel Officer of the center you prefer:

NASA Headquarters, (BPH) Washington 25, D. C.; Goddard Space Flight Center, Greenbelt, Maryland; Langley Research Center, Hampton, Virginia; Lewis Research Center, Cleveland, Ohio; Marshall Space Flight Center, Huntsville, Alabama; Ames Research Center, Mountain View, California; Flight Research Center, Edwards, California; Manned Spacecraft Center, Houston, Texas; Launch Operations Center, Cape Canaveral, Florida; Wallops Station, Wallops Island, Virginia; Western Operations Office, Santa Monica, California.

**NATIONAL AERONAUTICS AND  
SPACE ADMINISTRATION**

NASA is an equal opportunity employer. Positions are filled in accordance with Aero-Space Technology Announcement 252-B.





Calvin W. Emerson, Purdue BSME '60, MSME '62, inspects hollow air-cooled turbine blades after a test run of a first-stage prototype wheel in a turboprop engine power section. Emerson is one of numerous young engineers engaged in applied research on advanced gas turbine engines now under development by the Allison Division of General Motors. Blades of the type shown in the wheel have played a major role in boosting horsepower as much as 63% in development engines. These air-cooled blades operate in higher inlet gas temperatures with a lower blade surface temperature than uncooled blades, making possible improved fuel consumption as well as increased horsepower output.



● **ADVANCED TURBINE ENGINE DEVELOPMENT**—Allison, world leader in the design, development and production of turbo prop engines, is extending their capabilities to meet changing military needs.

Current programs greatly advancing the state of the art include developments for V/STOL applications and programs to maximize fuel economy and range through air cooled turbines and high temperature regenerative cycles.

And, in other fields, first and second stage rocket engine cases designed and produced by Allison for Minuteman have achieved a 100 per cent reliability record. Allison's steadily growing competence in the field is reflected in the forward strides made in titanium and glass filament-wound ICBM cases. Also, Allison has developed a highly efficient regenerative liquid metal cell that may point the way to a powerful, yet compact, electrical system for space-age applications.

Atomic Energy Commission's announcement of negotiations with Allison as prime contractor for development of MCR (Military Compact Reactor) also creates long-range opportunities in the nuclear field. Perhaps there's a place for you in the creative environment at Allison. Talk to our representative when he visits your campus. Let him tell you first-hand

**Allison**

THE ENERGY CONVERSION DIVISION OF  
GENERAL MOTORS, INDIANAPOLIS, INDIANA

what it's like at Allison where "Energy Conversion Is our Business."

*An equal opportunity employer*

# When is an Engineer a Portrait Painter



The answer is ALWAYS. His whole professional life is involved with sketching, drawing, drafting and rendering pictures of his ideas.

The working tool that gives the best graphic representation of his ideas is world-famous Castell #9000 drawing pencil. Milled by the exclusive microlet process for graphic saturation, it gives bold density of image. It glides across the paper without stumbling over gritty spots. Exceptionally strong in needlepoint or chisel point, it won't break under heavy pressure. Castell's 20 superb degrees, 8B to 10H, are controlled to a rigid standard of uniformity.

Many student and working engineers prefer Locktite Tel-A-Grade Holder with Castell #9030 Lead, identical in grade and quality to Castell drawing pencils.

Since engineers must rely on graphite to give expression to their ability, you'd be wise to use Castell, the drawing pencil of the masters. Make your selection at your college store today.

## A.W.FABER-CASTELL

Pencil Co., Inc.  
Newark 3, N. J.



## ENGINEERING CALENDAR

December

- 3 Atenna Lab Seminar, Prof. G. Deschamps  
4:00 p.m.—141 EE
- 4 "The Chemistry of Metal-Cyclopentadienyls and Metal-Cyclooctatetraenes," Dr. M. D. Rausch  
4:00 p.m.—112 Chem Annex
- 4 AIEE - IRE  
7:30 p.m.—151 EE
- 4 ASCE, "Consulting Engineer Practice," H. O. Johnson  
7:30 p.m.—116 E. Chem.
- 5 "Experiments on Theta Pinch Diagnostics and Injection of Plasma Across Magnetic Fields," Dr. F. Ribe  
2:45 p.m.—119 PL
- 5 Physical Metallurgy Colloquim, Dr. D. O. Thompson  
4:00 p.m.—218 Ceramics
- 5 ISGE
- 5 AIIE  
7:00 p.m.—253 MEB
- 5 SWE  
7:00 p.m.—141 EE
- 6 "Combustion Within Liquid Propellant Rocket Engines," Dr. Robert S. Levine  
4:00 p.m.—253 MEB
- 7 "Microwave Propagation in High Density Megneto-Plasmas and Its Application as a Diagnostic Tool," Dr. T. Consoli  
4:00 p.m.—141 EE
- 10 "On the Mapping by a Cross-Correlation Antenna System of a Distribution of Partially Coherent Radio Sources," R. MacPhie  
4:00 p.m.—141 EE
- 11 "Complex Compounds of Zero-Valent Platinum," Miss L. J. Park  
4:00 p.m.—112 Chem Annex
- 11 ACS  
7:30 p.m.—Illini Union General Lounge
- 11 ITE  
7:30 p.m.—Traffic Engineering Lab
- 11 MIS  
7:30 p.m.—220 TL
- 12 "Electron Microscopic Observation of Magnetic Domain Walls in Thin Films of Nickel and Cobalt," Dr. J. Silcox
- 12 EMS  
7:30 p.m.—220 TL
- 12 AFS  
7:00 p.m.—1 Foundry
- 13 "Quasi-Commutativity," Prof. I. N. Herstein  
4:00 p.m.—314 AH
- 14 "Diffusion-Controlled Bubble Growth," W. M. Buehl  
4:00 p.m.—116 E. Chem
- 14 ASME  
7:00 p.m.—319 Greg Hall
- 17 "The Conical Log Spiral Antenna," J. Dyson  
4:00 p.m.—141 EE
- 18 "The Analogy Between Chelate Stability and Inductive Effects on Aromatic Legands." E. J. Olszewski  
4:00 p.m.—112 Chem Annex
- 20 Vacation—1:00 p.m.
- 25 Merry Christmas



Opportunities at Du Pont for technical graduates—first of a series

# EVER HEAR OF A SOLUTION IN SEARCH OF A PROBLEM?



It happens at Du Pont. Frequently. That's because 1350 technically trained employees are engaged solely in pioneering research. They're in the business of discovery, development and follow-through. Sometimes the newly discovered chemical poses the question, what to do with it?

For instance, Dr. Thomas J. Swoboda, a member of the Central Research Department staff, and his associates recently discovered a new family of metallic compounds, chromium manganese antimonides. They're unusual materials. Over a specific temperature range they are magnetic. As temperature drops, the magnetism does too.

The chart, pictured with Dr. Swoboda, shows the sharp magnetic transition. To the right, the material is ferri-magnetic, to the left (at low temperatures), anti-ferromagnetic.

So we have a solution. Now to find the problem it will solve. This situation was largely true when nylon was discovered. Only later did we find the many problems which its unique characteristics would solve—from cord for airplane tires to plastics for gears.

### New products, new jobs

There's opportunity here for men of virtually every technical skill. For further information about chromium manganese

antimonides, and about working for Du Pont, just fill out and mail the coupon.



An equal opportunity employer

**Better Things for Better Living . . . through Chemistry**

E. I. du Pont de Nemours & Co. (Inc.)  
Nemours Building, Room 2531-11, Wilmington 98, Delaware

Please send me the literature indicated below.

- Du Pont and the College Graduate
- Mechanical Engineers at Du Pont
- Your Engineering Opportunities at Du Pont
- Chemical Engineers at Du Pont
- Chromium Manganese Antimonides Information

Name \_\_\_\_\_

Class \_\_\_\_\_ Major \_\_\_\_\_ Degree expected \_\_\_\_\_

College \_\_\_\_\_

My address \_\_\_\_\_

City \_\_\_\_\_ Zone \_\_\_\_\_ State \_\_\_\_\_

# Technoquips

The new recruit didn't salute the colonel. "Do you realize who I am?" asked the officer, "I run this entire camp. I'm in charge of twenty-five thousand soldiers."

"You got a good job," said the private, "don't louse it up."

\* \* \*

A certain Business Administration professor was unpacking some glassware he had received from the factory. Seeing that one jar was upside down he explained, "How absurd, this jar has no mouth." Turning it over he was once more astonished, "Why, the bottom's gone too," he explained.

\* \* \*

Imagine the little boy's embarrassment when he opened the wrong door in a train station waiting room and holstered "Extra paper."

\* \* \*

Chemistry Professor: "Young man, why aren't you taking notes?"

Student: "I don't have to sir, I've got my grandfather's."

\* \* \*

Then there was the M.E. who stepped up to the bar very optimistically, and two hours later went away very misty optically.

\* \* \*

While visiting America, a lovely French maiden discovered both her visa and her money had vanished. She was in great despair until an enterprising young sailor came to her rescue.

"My ship is sailing tonight," he said, "I'll smuggle you aboard, hide you in the hold and provide you with food and blankets. All it will cost you is a little affection."

She consented and he carried out his promise, visiting her several times daily. This went on for several weeks until one day the captain of the ship discovered the sailor paying her a visit. After the sailor had gone, he confronted the girl and upon hearing her sad story mused, "I admire the young seaman's ingenuity. However, I feel it's only fair that I inform you this is the Staten Island Ferry."

\* \* \*

Chem. Prof.: This fluid turns blue if your unknown is basic, and red if the unknown is acid."

Student: "Sorry, but I'm color blind. Got anything with a bell on it?"

## CHEMICAL ANALYSIS OF WOMEN

**ATOMIC WEIGHT:** Reputed to be 120. Isotopes are known through 90 to 180.

**OCCURRENCE:** Found both free and combined. In combined state it is found with man.

**PHYSICAL PROPERTIES:** All colors, sizes and shapes. Seldom found in pure state. Boils at nothing and will freeze without reason. Surface is usually covered with film of paint or oxide in various colors and depths. Unpolished specimen turns green in presence of highly polished one. All varieties melt if used correctly. Density is not so great as generally supposed.

**CHEMICAL PROPERTIES:** Highly explosive and dangerous in inexperienced hands. Extremely active in the presence of men. Possesses great affinity for gold, silver, platinum and all precious stones. Has the ability to absorb great quantities of expensive food and drink. May explode spontaneously when left alone with man. Sometimes yields to pressure. Fresh variety has great magnetic attraction, but ages rapidly.

**USE:** Chiefly experimental. Efficient cleaning agent. Acts as a positive or negative catalyst in the production of fevers.

\* \* \*

Freshman: I think your girl is spoiled.

Senior: No, it's just the perfume she is wearing!

\* \* \*

Professor: "Tell us what you know about nitrates."

Chem. E.: "I don't know much about them except that they're cheaper than day rates."

\* \* \*

Angry father: "What do you mean by bringing my daughter home at this hour of the morning?"

Engineer: "Have to be in class by eight."

\* \* \*

A man came into a drug store and asked for some invisible hairnets for his wife. When he got them from the clerk, he asked, "Are you sure they're invisible?"

"Sure they're invisible," was the answer. "I've been selling them all morning and we've been out of stock for a month."

He had been bitten by a dog, but didn't give it much thought until he noticed that the wound was taking a remarkably long time to heal. Finally he consulted a doctor who took one look at it and ordered the dog brought in. Just as he had suspected, the dog had rabies. Since it was too late to give the patient serum, the doctor felt he had to prepare him for the worst. The poor man sat down at the doctor's desk and began to write. His physician tried to comfort him.

"Perhaps it won't be so bad," he said. "You needn't make out your will, right now."

"I'm not making any will," replied the man. "I'm just writing out a list of people I'm going to bite!"

\* \* \*

Dear Sir:

I am engaged to Thelma and have been informed that you were seen kissing her. Kindly call at my fraternity house at seven Friday evening and make an explanation.

Jerry

Dear Jerry:

I have received a copy of your form letter and will be present at this meeting.

Bill

\* \* \*

Freshman: "I hate this damn place."

Sophomore: "It could be worse."

Junior: "It's rough, but think of the future I'm building!"

Senior: "I hate this damn place."

\* \* \*

"I don't like Bill," confided a coed to her roommate. "He knows too many naughty songs."

"Does he sing them to you?" asked her friend.

"Well, no—but he whistles them."

\* \* \*

What the Professors mean when they say:

See me after class . . . (It has slipped my mind)

Pop Quiz . . . (I forgot my lecture notes)

I will derive . . . (formula has slipped my mind)

Closed book quiz . . . (memorize everything, including the footnotes)

Open book quiz . . . (oil your slide rule and wind your watch)

Honor System . . . (alternate seats)

Briefly explain . . . (not less than 1000 words)

\* \* \*

"Whaddya mean, she's a drug addict?"

"Usually under the influence of some dope."

◆◆◆



# Kodak beyond the snapshot...

(random notes)

## Resist education

A certain engineering college recently asked us for a contribution not of money but of a small object suitably symbolic to deposit in the cornerstone of a new building. After thinking about it a bit, we sent three intricately shaped bits of metal so small that one of them got lost and never found its way into the box that will be opened some day to show our descendants the topics that engineers in 1962 regarded as fresh and promising. Is it not true that the engineering mind today is much occupied with working metals and semiconductors in ways to get as much performance as possible from as little bulk as possible?

Doggone right. In addition to making deposits in cornerstones, we have been busy expanding the line of photosensitive resists on which this hot new art so strongly depends. Everybody in it should be delighted to learn of KOR, a new one that's 10 to 15 times as sensitive to arc light and 30 to 100 times as sensitive to tungsten light as Kodak's well-known resist, KPR. This opens up the possibility of exposing KOR by a projected image instead of by contact printing, but the photographic speed is still a little low for an ordinary enlarger. A high-intensity projection printer will turn the trick.

If you don't even know what we are talking about, you have a dangerous blind spot in your education which you could repair quickly by sending a buck to Eastman Kodak Company, Rochester 4, N.Y. for a copy of "Photosensitive Resists."

## Cheaper than rubies maybe

We have entered the laser rod business. This decision looks logical enough. Lasers are a) very, very, very promising and b) connected by a strong thread to a technology about which we feel cocky—namely, non-silicate rare-earth glass, which we broke open commercially 25 years ago for photo lenses.

It was a thrill to hear that a rod of ours commenced action at a threshold of only 4 joules at room temperature. It emitted at  $1.06\mu$  by transition of  $Nd^{+++}$  from  $4F_{7/2}$  to  $4I_{9/2}$  (not down to ground state, which is  $4I_{15/2}$ ). Its time to technological obsolescence will be inevitably and indubitably short.

Meanwhile, for the people busy feeling out the ground rules of laser engineering for machine tools, weapons, etc., our neodymium-boron-barium-lanthanum-thorium-strontium glass is a good first choice because 1) neodymium needs no refrigerants (fluorescence doesn't return  $Nd^{+++}$  to ground state); 2)  $1.06\mu$  is convenient to phototubes, phosphors, and photography; 3) threshold for laser action comes at  $1/3$  the energy input that  $Nd^{+++}$  needs in silicate glass.

You have heard of ruby lasers? They depend on  $Cr^{+++}$ .  $Cr^{+++}$  depends on the crystal field to define its energy levels. Rare earths don't need a crystal field because their  $4f$  levels are shielded by  $5s$  electrons. Therefore they can work in glass, which can come big and homogeneous. Already a  $2'' \times 1/4''$  rod with ends tuned to reflect  $\sim 100\%$  and  $98\%$  at  $1.06\mu$  costs less than a decent used motorcycle.

## Adhesive findings

Mr. Guy V. Martin, 110 Yale Blvd., S.E., Albuquerque, N.M., has found EASTMAN 910 Adhesive vastly superior to soft solder for transmitting ultrasonic vibration. He has used up to 60 kc and electrical power inputs up to 200 watts at temperatures up to  $200^\circ F$ .

When he feeds energy like that through a solder bond from a transducer of laminated nickel sheets to an application tip, the solder deteriorates progressively and the transmission drops steadily. An EASTMAN 910 bond acts differently. Without apparent change, it transmits three to four times as long as solder takes to reach disintegration.

When the 910 bond finally snaps, it does so all at once with an audible snap. In the case of aluminum bonded to the nickel, rupture always takes place between the adhesive film and the aluminum. With other metals, plastics, ceramics, or glass bonded to the nickel, the rupture divides itself between one interface or the other and doesn't appear within the film.

Mr. Martin claims that for some 30 years Kodak has been very obliging in furnishing him helpful information from time to time. We claim that in volunteering his adhesive findings, he has now amply repaid us. We shall be very happy to furnish you, too, with helpful information for 30 years. EASTMAN 910 Adhesive is obtainable in a \$5 sample kit from Eastman Chemical Products, Inc., Kingsport, Tenn. (Subsidiary of Eastman Kodak Co.). It develops great strength within seconds.

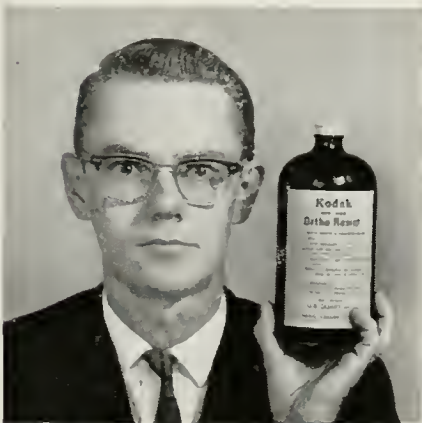

ALL SORTS OF PRODUCTS, ALL SORTS OF CAREER DEDICATION AT KODAK FOR THE SCIENTIFICALLY ORIENTED, B.S., M.S., OR PH.D.

EASTMAN KODAK COMPANY  
Rochester 4, N.Y.

AN INTERVIEW  
WITH G.E.'s  
DR. GUY SUITS,  
VICE  
PRESIDENT  
AND DIRECTOR  
OF RESEARCH



Dr. Suits has managerial responsibility for the General Electric Research Laboratory and as a member of the Company's Executive Office he is directly concerned with G.E.'s over-all research programs and policies. He joined G.E. in 1930 as a physicist, and holds 76 patents, is Chairman of the Directors of Industrial Research, member of the National Academy of Science, Director of American Institute of Physics, previous Chairman of Naval Research Advisory Committee and Fellow of the AIEE, AAAS, and IRE, and has been Vice President and Director of Research since 1945.

For complete information about these General Electric training programs, and a copy of Dr. Suits paper "The New Engineer And His Scientific Resources," write to: Personalized Career Planning, General Electric Company, Section 699-05, Schenectady 5, New York.

# How Scientists and Engineers Work Together in Industry

**Q. Dr. Suits, I've heard a good deal about the scope of your programs. Is your research mostly in physics and electronics?**

A. This is a common misconception. The work of the many laboratories of General Electric "covers the waterfront" in science and in advanced engineering technology. Some laboratories specialize in electronics research, others in atomic power, space technology, polymer chemistry, jet engine technology, and so forth. Actually, the largest single field represented by the more than 1000 Ph.D. researchers in General Electric is chemistry.

**Q. Is this research performed principally by people with Ph.D. degrees in science?**

A. General Electric research covers a broad spectrum of basic and applied work. At the Research Laboratory we focus largely on basic scientific investigations, much as in a university, and most of the researchers are Ph.D.'s. In other Company laboratories, where the focus is on applied science and advanced engineering, engineers and scientists with B.S. and M.S. degrees predominate. Formal college training is an important preparation for research, but research aptitudes, and especially creative abilities, are also very important qualities.

**Q. What are the opportunities for engineers in industrial scientific research and how do scientists and engineers work together in General Electric?**

A. Classically, engineers have been concerned with the problem "how," and scientists with the question "why." This is still true, in general, although in advanced development and in technological work scientists and engineers work hand-in-hand. Very close cooperation takes place, especially in the increasingly important fields of new materials, processes, and systems. Certainly in General Electric, a person's interest in particular kinds of problems and his ability to solve them are more important than the college degree that he holds.

**Q. What does it mean to an engineer to have the support of a large scientific research effort?**

A. It means that the engineer has ready access to the constant stream of new concepts, new materials, and new processes that originate in research, and which may aid his effort to solve practical problems. Contact with research thus provides a "window" on new scientific developments—world-wide.

**Q. How does General Electric go about hiring engineers and scientists?**

A. During each academic year, highly qualified technical people from General Electric make recruiting visits to most college campuses. These men represent more than 100 General Electric departments and can discuss the breadth of G.E.'s engineering and science opportunities with the students. They try to match the interests of students and the Company, and then arrange interview visits. The result of this system is a breadth of opportunity within one company which is remarkable.

Experienced technical people are always welcome, and they are usually put in contact with a specific Company group. Where no apparent match of interests exists, referrals are made throughout General Electric. In all cases, one finds technical men talking to technical men in a really professional atmosphere.

**Q. Are there training programs in research for which engineering students might be qualified?**

A. There certainly are. Our 2-year Research Training Program at the General Electric Research Laboratory gives young scientists a chance to work with experienced industrial research scientists before carrying out research and development on their own.

In addition, there are seven Company-wide training programs. Those that attract the largest number of technical graduates are the Engineering and Science, Technical Marketing, and Manufacturing Training Programs. Each includes on-the-job experience supplemented by a formal study curriculum.

Of course, not all graduates are hired for training programs. In many cases, individuals are placed directly into permanent positions for which they are suited by ability and interest.

GENERAL  ELECTRIC



ILLINOIS

No. 3 - 25c

# TECHNOGRAPH

JAN 1 1963  
LIBRARY



*Small*

Paul Rand



## Atomic Power... and the race to outer space

If man is to reach the other planets... and get back to earth...he has three immediate choices: (1) A conventional rocket, many times the size of anything now existing. (2) A rendezvous in orbit, where the spaceship would be assembled. Or (3) an atomic-powered rocket ship. Because atomic power's efficiency is the highest, many experts believe the practical choice for space exploration is an atomic rocket engine.

Westinghouse and Aerojet General are now working with AEC's Los Alamos Scientific Laboratory to design such an engine. This industry-government team is working under the direction of the Joint Space Nuclear Propulsion Office of the AEC and NASA.

Learn more about the diverse and challenging space age research and development projects at Westinghouse, an equal opportunity employer. Talk with the Westinghouse representative when he visits your campus, or write L. H. Noggle, Westinghouse Educational Department, Ardmore and Brinton Roads, Pittsburgh 21, Penna. You can be sure...if it's

Westinghouse





**Editor-in-Chief**  
Wayne W. Crouch

**Associate Editor**  
Gary M. Daymon

**Office Manager**  
Thelma Allen

**Production Manager**  
Scott Weaver

**Circulation Manager**  
Gary Bilow

**Editorial Staff**  
Art Becker  
Larry Druffel  
Ted Morange  
Bill Small  
James Walters

**Business Staff**  
Phillip Johnson  
Wayne Worthington

**Production Staff**  
Mike Glowacz

**Circulation Staff**  
Bob Bittner  
Paul Gihring  
Dick Kolb  
George Muellner

**Photography**  
Jay Dickinson  
Joe Figueira

**Advisors**  
R. W. Bohl  
P. Bryant  
W. M. Hudson  
E. C. McClintock

# THE ILLINOIS TECHNOGRAPH

Volume 78; Number 3

December, 1962

## Table of Contents

### ARTICLES

The University of Illinois Radio Telescope, Theodore Morange	10
Concrete and the New Look	14
Information Retrieval	Thelma Allen 18

• • • • •

### FEATURES

Tech Says	Gary Daymon 4
The Dean's Page	Dean H. L. Wakeland 12
Technocutie	20
Photos by Dickinson and Figueira	
News and Views at the U. of I.	Gary Daymon 22
Engineering Calendar	29
Technoquips	32

### MEMBERS OF ENGINEERING COLLEGE MAGAZINES ASSOCIATED

Chairman: J. Gale Chumley  
Louisiana Polytechnic Institute  
Ruston, Louisiana

Arkansas Engineer, Cincinnati Coopera-  
tive Engineer, City College Vector, Colorado  
Engineer, Cornell Engineer, Denver Engi-  
neer, Drexel Technical Journal, Georgia  
Tech Engineer, Illinois Technograph, Iowa  
Engineer, Iowa Transit, Kansas Engineer,  
Kansas State Engineer, Kentucky Engineer,  
Louisiana State University Engineer, Louisi-  
ana Tech Engineer, Manhattan Engineer,  
Marquette Engineer, Michigan Technic, Min-  
nesota Technologist, Missouri Shamrock, Ne-  
braska Blueprint, New York University  
Quadrangle, North Dakota Engineer, North-  
western Engineer, Notre Dame Technical  
Review, Ohio State Engineer, Oklahoma  
State Engineer, Pittsburgh Skyscraper, Pur-  
due Engineer, RPI Engineer, Rochester In-  
dicator, SC Engineer, Rose Technic, South-  
ern Engineer, Spartan Engineer, Texas  
A & M Engineer, Washington Engineer,  
WSC Technometer, Wayne Engineer, and  
Wisconsin Engineer.

The Cover: by Bill Small

"R. T. Lance for Nakobov"

Copyright, 1962, by Illini Publishing Co. Published eight times during the year (Oc-  
tober, November, December, January, February, March, April and May) by the Illini  
Publishing Company. Entered as second class matter, October 30, 1920, at the post  
office at Urbana, Illinois, under the Act of March 3, 1879. Office 215 Engineering  
Hall, Urbana, Illinois. Subscriptions \$1.50 per year. Single copy 25 cents. All rights  
reserved by *The Illinois Technograph*. Publisher's Representative — Littell-Murray-  
Barnhill, Inc., 737 North Michigan Avenue, Chicago 11, Ill., 369 Lexington Ave.,  
New York 17, New York.

The undeniable thrill of  
successful accomplishment  
can be yours as a member  
of the aggressive,  
visionary  
team now forging  
a new future at **DELCO**

solid state electronics ●



Make an appointment to talk with our  
interviewer when he visits your campus,  
or for additional information write:  
MR. C. D. LONGSHORE, Supervisor  
—Salaried Employment:

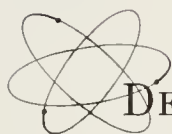

DELCO RADIO DIVISION OF GENERAL MOTORS

KOKOMO, INDIANA

*An equal opportunity employer*



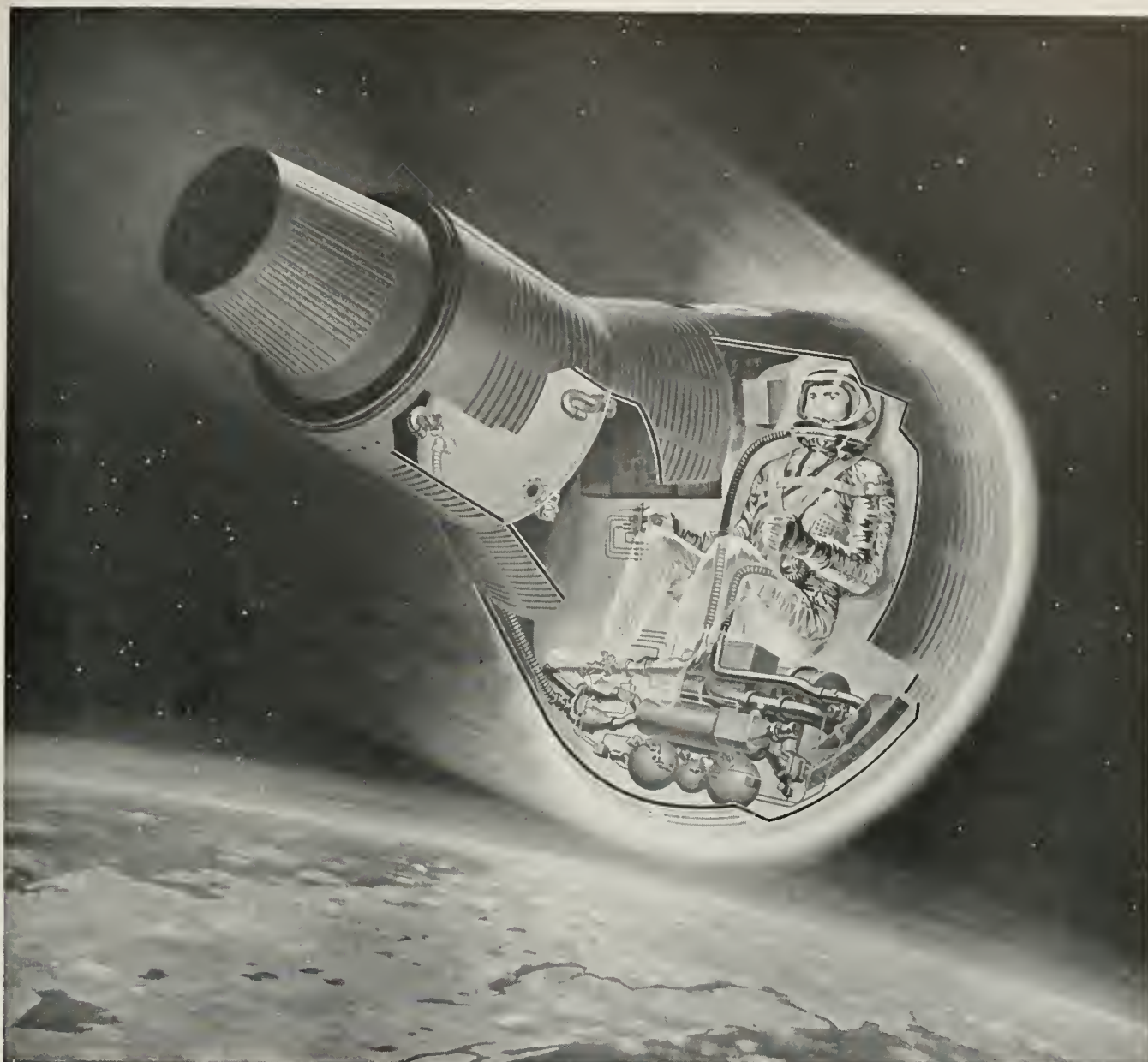

## Garrett's Life Support System Sustains America's First Orbital Astronaut

Garrett has provided the environmental system vital to the space flights of the NASA-McDonnell Project Mercury capsule. This 39 lb system controls gaseous composition, temperature and pressure within the capsule for both suborbital and orbital flight.

The system automatically maintains an oxygen atmosphere within a specified pressure range in suit and cabin circuits during all phases of flight. It also removes carbon dioxide, water and solid particles from the oxygen, and controls the

temperature and humidity to comfortable levels within the pressure suit. In addition, the system cools electronic equipment within the capsule.

Garrett also designs, develops and manufactures many other major systems and components for aircraft, space and industry.

For further information about other interesting projects and career opportunities with The Garrett Corporation, write to Mr. C. D. Bradley in Los Angeles.

Garrett is an "equal opportunity" employer.



THE GARRETT CORPORATION • AiResearch Manufacturing Divisions • Los Angeles 9, California • Phoenix, Arizona • other divisions and subsidiaries: Airsupply-Aero Engineering • AiResearch Aviation Service • Garrett Supply • Air Cruisers • AiResearch Industrial • Garrett Manufacturing Limited • Garrett International S. A. • Garrett (Japan) Limited

## A Solution (for a Change)

# The New Approach

By Gary Daymon, EE '64

*Everyone has enough problems. When someone introduces one and includes a solution which can be easily effected, TECHNOGRAPH acts. The new approach calls for a simple redirection of energies and is likely to bring recognition and personal satisfaction to those involved.*

With over a 30 per cent increase in technical manpower demands last year alone plus clear indications that this demand will continue over the next decade, the public seems to assume that engineering college enrollment will automatically increase. Yet quite the opposite has been true.

A recent survey by EMC, the Engineering Manpower Commission of the Engineers' Joint Council, shows a 2.3 per cent average drop in freshman engineering enrollment throughout the country during 1962. This authoritative figure was obtained directly from responses by over 200 engineering colleges, which represented more than 90 per cent of the total colleges granting engineering degrees.

The 1962 decrease in engineering enrollment alone would not be exceptionally alarming except that it is the continuation of a four-year decline which began in 1958. (See Graph.) With this persistent reduction in freshman engineering enrollment, the prospect of a drop in engineering graduates for the next four years is assured. As a result, it will be six or more years before the number of engineering graduates with bachelors degrees can again reach the present level of 36,000. This year alone there was a six per cent drop in engineering baccalaureate degrees from 1961.

### Need Critical

The need for a greater emphasis on engineering by educators and the public in general is becoming increasingly important and alarming if not catastrophic. Space efforts alone plan to absorb thousands of highly trained men and women. Although current space shots are labeled "scientific," each blastoff requires 95 engineers for every five scientists. In the same way, growing military defense

requirements and the increased needs of a steadily expanding civilian economy will require additional supplies of top-grade engineers.

As a safeguard of our democracy, the critical role of the engineer cannot be emphasized enough. Currently the Soviet Union is graduating over 120,000 engineers each year of a quality roughly comparable with the United States' 36,000. Further, Communist China is putting a tremendous premium on the development of engineers and scientists. Although it is difficult to determine the quality of China's technical manpower, best estimates indicate an 80 per cent increase in the number of Chinese engineering graduates in the past ten years.

### Current Solutions Ineffective

Many solutions to the growing U. S. technical manpower deficit are being investigated. For example, immigrant engineers are finding the United States a haven for their talents. During the past decade nearly as many engineers, some 30,000, immigrated to the United States as were graduated by the nation's engineering schools.

Manifestly, there are more than ample engineering demands to absorb the imported engineering talents of other nations. Significant contributions by such men as Werner von Braun, mathematician Albert Einstein, and airplane designer Igor Sikorsky are immeasurable. Yet, what can and are we as Americans doing to rectify this alarming and frightening deficit?

The past four years of national emphasis on engineering have surprisingly failed to increase freshman engineering enrollment. In our own state, some progress, though not enough, is being made. Presently, the U. of I.'s Engineering Alumni Commit-

tee, founded with the aid of Dean Everitt in 1950, is perhaps the most active group which is conscientiously studying the problem in an effort to correctly and adequately counsel potential engineering students in high schools. (See "Engineering Alumni Convention," TECHNOGRAPH, Nov., 1962, p. 29.) Its main goal is to inform and direct high school students with technical ability.

At the Engineering Alumni's last convention, as reported by the November TECHNOGRAPH, they devoted much of their time to the problems facing counselors in advising bright high school coeds who are interested in engineering. This source of versatile and competent engineering talent is finally beginning to receive the attention it has so long deserved. (See "Skirts and Slide Rules," TECHNOGRAPH, April, 1962, p. 5.) Without a doubt, young women offer the greatest immediate source for improving the number of engineering enrollments and degree recipients. Presently, women account for only one out of 360 (0.28 per cent) engineering degrees granted in the United States. Encouragingly, current U. S. enrollment figures show a 0.29 per cent rise in women engineering enrollment with one female for every 175 males (0.57 per cent) in engineering. Yet, this rise is far short of the 50 per cent of women engineers in the Soviet Union and the 40 per cent in Red China.

Another channel being studied to relieve the demand for technical manpower is the two year technical institute and high school technical training programs. This type of training is being designed to supply technicians to support engineers whose jobs are becoming increasingly more complex. A recent Educator's Conference on Mechanical Technology, which met at the U. of I. to discuss curriculum content and other problems in these programs, recognizes the need for this supply of technical manpower.

### A New Approach

Efforts by educators are, needless to say, invaluable; yet one potential source for increasing engineering enrollment has been virtually untapped: the influence students already enrolled in engineering can have on prospective engineering students in high schools.

Educators are partially successful in their efforts, yet high school students have serious misconceptions about engineering students. As odd as it may seem to some engineering students, many high school students have restricting fears about engineering. A countless number have heard that an engineer is a victim of his own profession with no knowledge or de-



sire to know about other facets of life. The legend of the "narrow" engineer is still persistent despite the tremendous advances which have been made to correct this once legitimate accusation. (See "Requirements Change in Engineering," TECHNOGRAPH, Oct., 1962, p. 19.)

High school students must be presented with the true picture of engineering in an accurate perspective with other fields so they can recognize the profession for what it is. They can then select their high school courses intelligently to prepare for their college education. They must be informed of the latest curriculum changes being made to keep engineering students abreast of their profession and be told about the latest special courses and curricula being offered to fit individual needs. These may not be the needs of a "strict," purely technical engineer, but rather as a writer, administrator, technical personnel manager or executive. Several courses in writing, reading, and discussion already exist. For instance, Dean Wakeland is currently organizing a special course in which students can read a number of great books during the summer and receive credits toward an engineering degree.

The areas of misconception and lack of information mentioned do not even begin to scratch the surface. Guidance for engineering minded high school students is a vast area and one which can be adequately presented only by persons in or closely connected with the engineering field—such as engineering students! Only by properly informing high school students can we be assured of the needed quantity and quality. The question asked immediately by many students who agree is "where and how do we start?"

Perhaps no single solution exists to organize students in this crusade; however, the present engineering societies, professional and honorary, are the most logical sources for supporting immediate action. They possess the members and funds to assemble, print, and distribute informative pamphlets presenting the student engineer's view of engineering, the view welcomed most by high school principals and science teachers. Likewise, these organizations can easily unite under the direction of the Student Engineering Council to visit high schools on an informal basis and meet with technically minded high schools students and their advisors.

When systematically organized, these visits would require a minimum of effort on the part of each individ-

ual. Junior Academy of Science Chapters, JETS (Junior Engineering Technical Societies), as well as high schools could be periodically visited, preferably during the spring semester, and informed of current engineering events such as the U. of I. Open House and the advantages to be gained from these visits. Indeed, the more than 25 engineering professional and honorary organizations on the U. of I. Engineering Campus include members from almost all the state high schools, therefore, easy and inexpensive advisory-service coverage is guaranteed.

Colored slides, movies, and other visual supplements can be prepared for the organizations' members. It is entirely possible, too, that such a venture would receive the financial as well as moral support of the College of Engineering and similar institutes throughout the state. Indeed, an avalanche of nationwide backing of "Engineering Students for Engineers" efforts could be the result of initial moves by an energetic organization at the U. of I.

The experience benefits to engineering students of organizing, explaining, and communicating are self evident, not to mention the personal satisfaction every student will feel. Writing, speaking, and presentation of ideas are essential skills for engineering graduates.

The need for immediate action on the part of engineering students to reverse the current downward trend of enrollments is equally self-evident. Personnel and organizations for such an endeavor already exist in the form of engineering professional and honorary societies and the awards of accomplishment and individual satisfaction cannot be overemphasized. The challenge is real, growing, and urgent. . . . It is up to us, as engineering students and future engineers, to accept our responsibilities as American citizens, now as well as later, and come to the support of what is without a doubt the greatest cause of all—the assured defense of the U. S. through continued technical advancement with a sufficient supply of technical manpower.

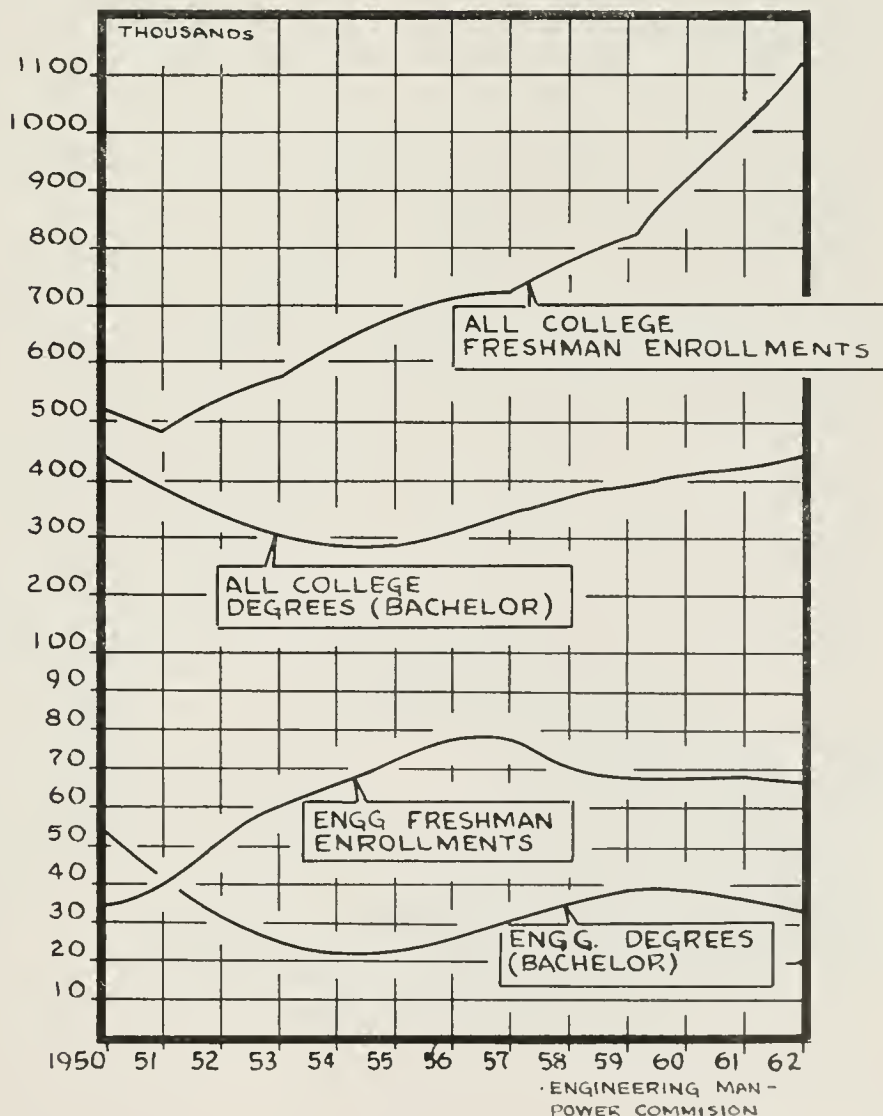

# HOW CUTLER-HAMMER CREATIVE ENGINEERING HELPS INDUSTRY REACH ITS AUTOMATION GOALS

*Ralph Millermaster, vice president,  
engineering and development, answers the questions  
most frequently asked by students regarding  
Cutler-Hammer's role in industrial automation*



## **Q. How long has Cutler-Hammer been in Automation?**

**A.** Long before the word "automation" was coined.

Many company historians view the installation of the first electric turret-turning control for battle-ships as our original "automatic system" achievement. In 1904, trials aboard the U.S.S. INDIANA so improved rapid-fire and gunnery-control scoring that identical systems were installed on sister ships.

## **Q. How does your Automation—or "System Control"—effort differ from your other control business?**

**A.** We work in two areas of control. One involves research, development and manufacture of standardized electric control components and apparatus. Here the customer orders from us through a bill of material.

The automation customer is different. He has no bill of material—he has a problem. He needs to improve production or quality, or to reduce his unit costs. He isn't buying "hardware," he's seeking a creative solution to a challenging problem . . . and that's what our engineers provide.

## **Q. Assuming I decide to work for a control manufacturer, why Cutler-Hammer?**

**A.** The most compelling reason is our continuing interest and extensive experience in "System Control." This is the life of our company and distinct career advantages result from this concern.

Our engineers are forced to apply a combination of advanced electronic and electrical engineering

know-how to solve a customer's manufacturing problem. They start with a thorough grounding in the customer's products—how he moves and works the materials he manufactures. Then they apply their technical knowledge to create a practical solution. We have a Materials Handling group, a Metal Processing group, and many other industry groups composed of young, creative-minded engineers.

And, we don't "stock-pile" our engineering talent. Every engineer we hire is expected to contribute quickly and directly to the team effort.

## **Q. How does Cutler-Hammer approach an automation job?**

**A.** We have learned that a sizable system needs painstaking coordination between many groups—project teams, engineering, maintenance and purchasing personnel at the customer factory and headquarters locations . . . machinery builders, motor manufacturers, contractors and many more.

We view this coordination as one of our primary functions, and fulfill it by furnishing all responsible groups and individuals the information they want and need to guarantee an efficient dovetailing of effort.

We organize a coordinating task force for each project, headed by a lead engineer and staffed by engineers representing every necessary technical discipline. That task force is charged with three duties:

1. Create a system that will solve the problem.
2. Design the system within the time allotted.
3. Install the system at a cost which pays its way for the customer and provides us a fair profit.

Task forces work together in a modern 500,000 square foot plant specifically designed to house every activity involved in the evolution of the complete system. Every possible step has been taken to provide a climate that is conducive to creative planning and development.

This approach has paid off! Long recognized as a leader in standardized motor control, Cutler-Hammer is more and more being regarded as a major contributor in industrial automation. Our automation credentials include innovations in every industrial field from continuous process lines to newspaper mail rooms.

## **Q. How do I learn more about Cutler-Hammer's automation capability and the career opportunities for engineers?**

**A.** By visiting your Placement Office . . . picking up the Cutler-Hammer literature on the rack, and talking to your Placement Director. Or, you can write direct to T. B. Jochem, Cutler-Hammer, Milwaukee, Wisconsin, for a complete kit of information. And, I hope that you will plan to meet with our representative when he visits your campus.

WHAT'S NEW FOR YOU? ASK...

## **CUTLER-HAMMER**

Cutler-Hammer Inc., Milwaukee, Wisconsin • Divisions: AIL; Mullenbach • Subsidiaries: Uni-Bus, Inc.; Cutler-Hammer International, C.A. Associates: Cutler-Hammer Canada, Ltd.; Cutler-Hammer, Mexicana, S.A.





**HOWARD HUGHES DOCTORAL FELLOWSHIPS.** If you are interested in studies leading to a doctor's degree in engineering or physics, you are invited to apply for one of the several new awards in 1963 on the Howard Hughes Doctoral Fellowship Program.

This unique program offers the doctoral candidate the optimum combination of high-level study at an outstanding institution plus practical industrial experience in the Hughes laboratories.

Each Howard Hughes Doctoral Fellowship usually provides about \$8,000 annually. Of this amount approximately \$1,800 is for tuition, thesis and research expenses, other academic fees and books. The remainder is composed of salary earned by the fellow and a stipend.

Howard Hughes Doctoral Fellowships are open to outstanding students. A master's degree, or equivalent graduate work, is essential before beginning the Fellowship Program.

**HUGHES MASTERS FELLOWSHIPS.** The Hughes Masters Fellowship Program offers unusual opportunities for education leading to a master's degree . . . and, in addition, provides each fellow with practical experience in the professional field of his choice.

New awards will be made in 1963 to qualified applicants possessing a bachelor's degree in engineering or physics.

The great majority of the award winners will be assigned to the **WORK STUDY PROGRAM** and will attend a university sufficiently near a facility of the Hughes Aircraft Company to permit them to obtain practical experience in a professional field of their choice, by working at the company at least half time. Those associated with a Southern California facility usually attend the University of Southern California or the University of California, Los Angeles. An

appropriate stipend will be awarded.

A small, highly selected group will be offered a **FULL-STUDY PROGRAM**. Participants in this program will receive fellowships that permit them to attend an outstanding university on a full-time basis during the regular academic year with a substantial stipend.

After completion of the Master's Program, fellows are eligible to apply for **HUGHES STAFF DOCTORAL FELLOWSHIPS**.

**For both programs**, typical areas of research and development to which fellows may be assigned while working for Hughes include: weapons control systems, guidance and control systems, infrared search and track systems, advanced propulsion systems . . . parametric amplifiers, masers, lasers, microwave tubes and devices, electron-tube and solid-state displays, semiconductor materials, digital computers, antenna arrays, aerospace vehicles and trajectories . . . plasma electronics; solid-state, atomic, nuclear and aerospace physics; propagation, mechanics of structures, chemistry and metallurgy . . . systems design and analysis, human factors and analysis, network analysis and synthesis . . . microminiaturization, communications, data processing and digital computers, information theory, simulation.

The classified nature of work at Hughes makes American citizenship and eligibility for security clearance a requirement.

**Closing date for applications:** February 1, 1963

**How to apply:** To apply for either the Howard Hughes Doctoral Fellowship or the Hughes Masters Fellowships write Dr. C. N. Warfield, Manager, Educational Relations — General Office, Hughes Aircraft Company, Culver City, California.

# Hughes Fellowship Programs

*Creating a new world with ELECTRONICS*



HUGHES AIRCRAFT COMPANY

An equal opportunity employer.



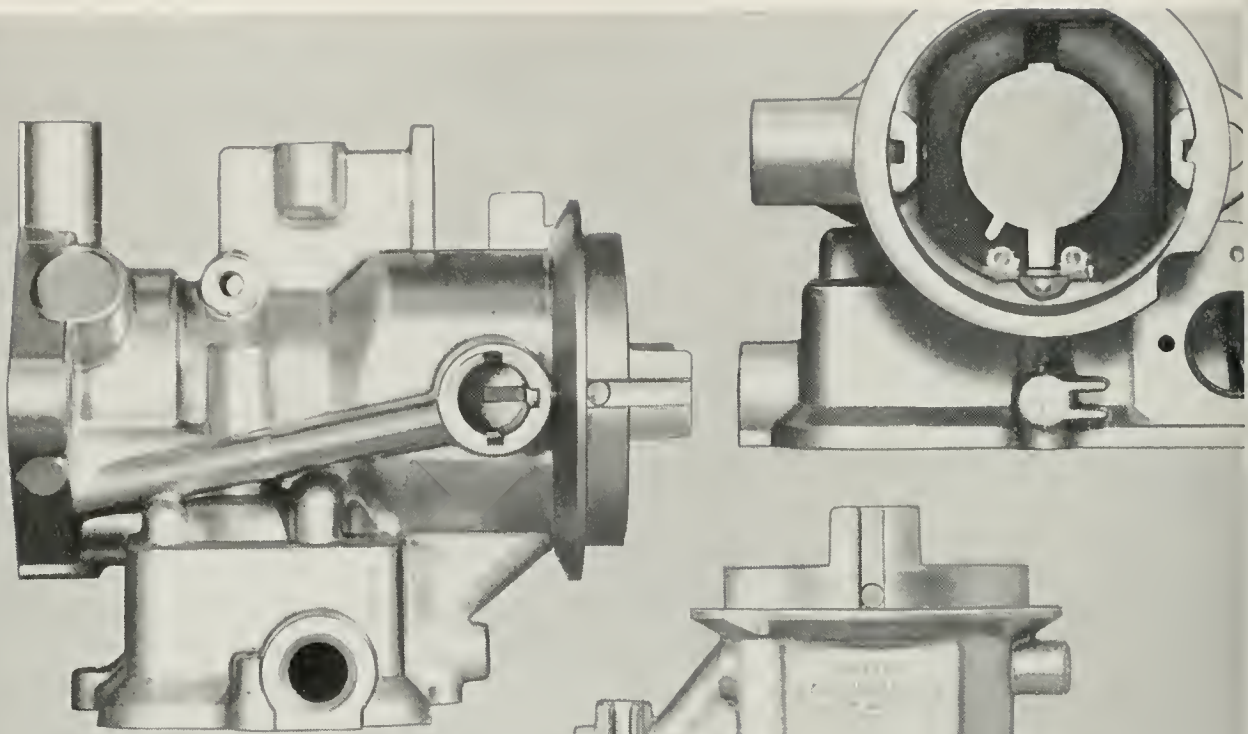

## A Masterpiece of the Die Casting Process

(by New Products)

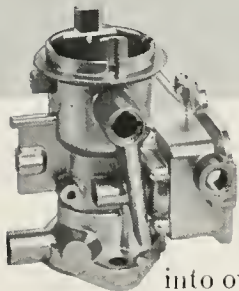
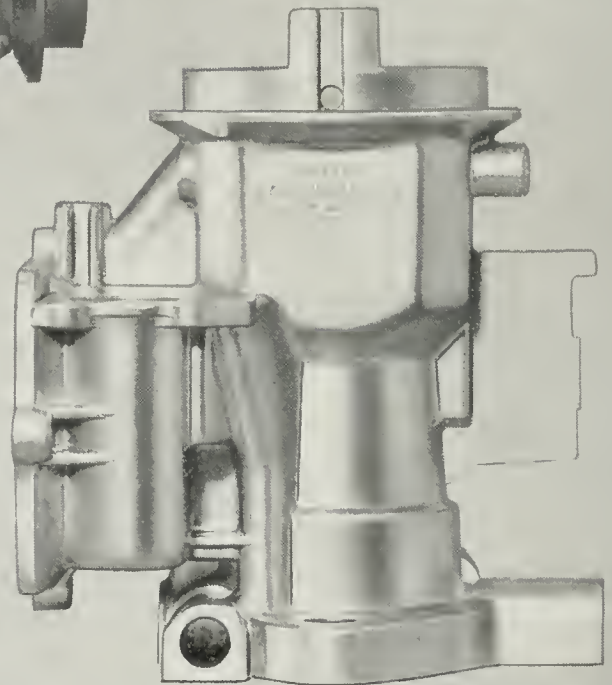

One indication we have of the steadily increasing competence of the die casting industry is the amazing precision which can be cast directly into our products. This carburetor body casting, for example, is the product of one extremely complicated casting operation in which die segments are withdrawn in six directions to form its many surfaces, orifices, and ducts. Thus, machine finishing is greatly reduced. To reach and maintain this degree of excellence, the die casting industry requires practical creative engineers . . . the kind of people who are willing to go into unexplored areas to develop new, better solutions to ever-changing problems. If you are that kind of engineer now . . . or plan to be . . . we would appreciate receiving your resume.

# NEW PRODUCTS CORPORATION

BENTON HARBOR, MICHIGAN



# Engineers

*In Choosing a Career,  
Consider these  
Advantages—*

*Location:* Fisher is basically an "Engineering" company with 1,500 employees located in a pleasant midwest community of 22,000. It's less than 10 minutes to the Fisher plant from any home in Marshalltown.

*Type of work:* You'll become a member of an engineering team that has produced some of the outstanding developments in the field of automatic pressure and liquid level controls.

*Growth:* Fisher's products are key elements in automation which assures the company's growth because of the rapid expansion of automation in virtually every industry.

*Advancement:* Your opportunity is unlimited. It is company policy to promote from within; and most Fisher department heads are engineers.

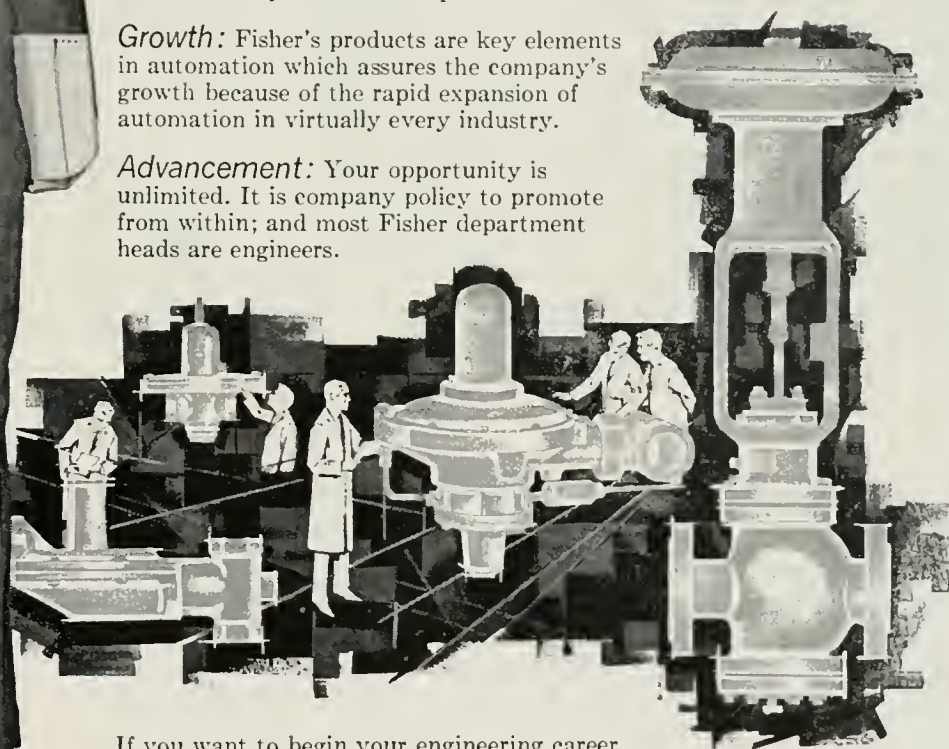

If you want to begin your engineering career with one of the nation's foremost research and development departments in the control of fluids, consult your placement office or write directly to Mr. Cecil Johnson, Chief Engineer, FISHER GOVERNOR COMPANY, Marshalltown, Ia.

*If it flows through pipe  
anywhere in the world  
chances are it's controlled by...*



# THE UNIVERSITY OF ILLINOIS RADIO TELESCOPE

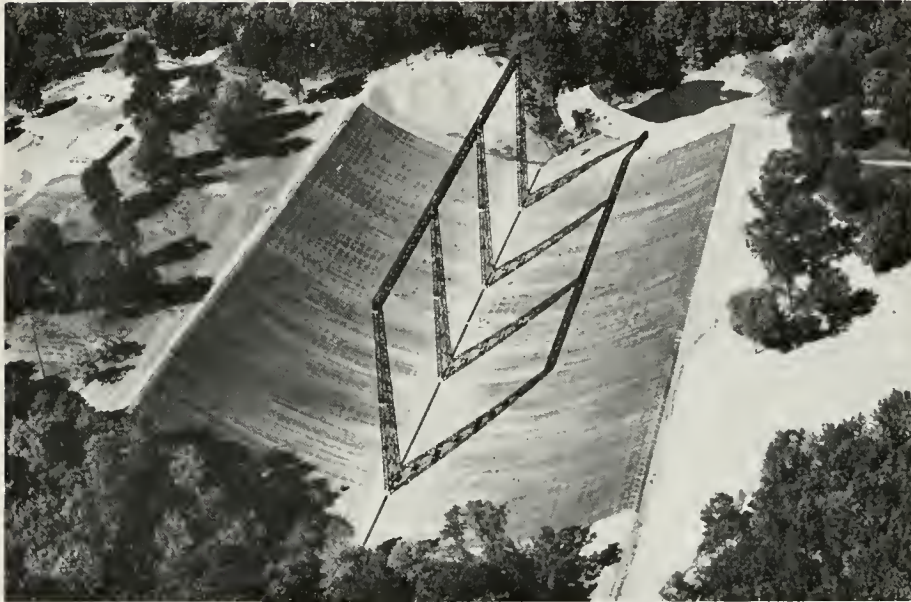

Aerial view of the University of Illinois' 5-acre radio telescope at the Vermilion River Observatory, 5 miles southeast of Danville.

by

T  
H  
E  
O  
D  
O  
R  
E  
  
M  
O  
R  
A  
N  
G  
E

EE '65

University of Illinois astronomers now have an instrument which enables them to listen to distant galaxies never seen with their optical telescopes. Their new device is a six hundred- by four hundred-foot "radio telescope," the largest of its type. Built in cooperation with the Department of Electrical Engineering, the radio telescope began operation on November 9.

As mentioned above, the radio telescope can "see" certain astronomical sources of electromagnetic waves that are invisible to the optical telescope. Stellar dust clouds, which are opaque to light waves, block optical observation of many galaxies beyond our own Milky Way. However, some of these galaxies also emit radio waves which pass through the dust clouds unattenuated, so we may detect many of the otherwise hidden galaxies with a radio telescope. Also, a possibility exists that some radio sources are not "stars" in the usual sense of the word; they emit radio waves but not light waves.

The radio telescope cannot locate sources as accurately as the optical telescope can, but its ability to detect previously unknown astronomical bodies offsets this disadvantage. Using the Illinois radio telescope, Professors George W. Swenson and George C. McVittie and their staff have already begun a five-year survey to compile a catalog of as many sources as possible which lie beyond the Milky Way. (Professor Swenson is of the Department of Electrical Engineering and the Department of Astronomy. Professor McVittie is the head of the Department of Astronomy.) Current catalogs disagree in some respects, and the new data which will be contributed by the Illinois radio telescope may help radio astronomers compile a more accurate and extensive catalog. (Initial comparisons of data have already been made with radio telescope installations in Washington, D.C. and the Netherlands.) This revised catalog may then tell astronomers more about the universe, for instance, the nature of its ex-

pansion. Astronomers already know from optical observations that all the bodies of the universe are continually moving apart from each other. However, they do not know whether this expansion is accelerating, decelerating, or continuing at a constant rate. Radio telescope research may give some clues as to the true nature of this expansion. (For a further discussion of the universe's expansion, see "Some Deductions About the Expanding Universe" by Carl J. Stehman which appeared in the April, 1961, *Technograph*.)

## General Operation

The University of Illinois radio telescope has two main components: a wire mesh *reflector* in the shape of a parabolic cylinder and a tower-supported array of *receiving antennas* mounted along the focal line of the reflector. (The focal line of a parabolic cylinder is analogous to the focal point of a parabola.) Signals or rays from distant radio sources incident upon the reflector as in Fig. 1 are



focused on the receiving antennas. The signals are then fed to the receiving-recording device with coaxial cable. An example of the recorded output of the telescope is shown in Fig. 2. Only signals whose frequency is 611 megacycles are recorded. The telescope is designed to give optimum performance at this frequency. It responds to signals of other frequencies, but they are filtered out in the receiving device. The recording in Fig. 2 shows a graph of received signal strength from the constellation Cygnus plotted against time. Cygnus is in our own galaxy. The signal strength rises and falls as the telescope is moved by the rotation of the earth through the only position at which signals may be

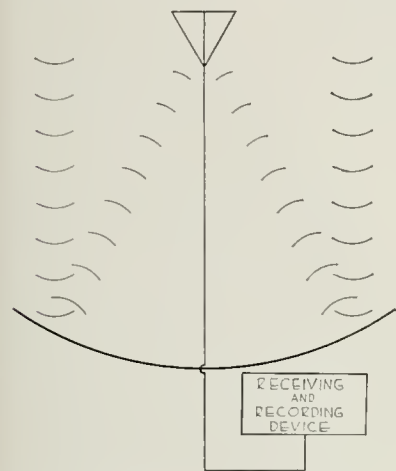

Figure 1: Schematic diagram of the radio telescope and its receiving-recording device. Two signals are shown being focused on receiving antennas.

received from Cygnus. Recordings similar to Fig. 2 will be used to compile the Department of Astronomy's catalog of radio sources beyond our galaxy. Some of the radio signals which are being received from beyond our own galaxy left their sources over 200 million years ago.

The radio telescope receives signals from only a small section of sky at any given time. That is, its received beam is a narrow one. A received beam may be thought of as a particular group or "bundle" of rays streaming in from space and striking the telescope's reflector. If the rays of this bundle are all parallel or nearly parallel to each other, the beam is said to be narrow. A received beam of this type is called a pencil beam. It is important to realize that the adjective *pencil* implies a pencil shape beam and not a pencil size beam, for the received beam is about four hundred feet in diameter. This pencil-shape characteristic of the beam enables the University's radio astronomers to know from what part of the sky a received signal has come.

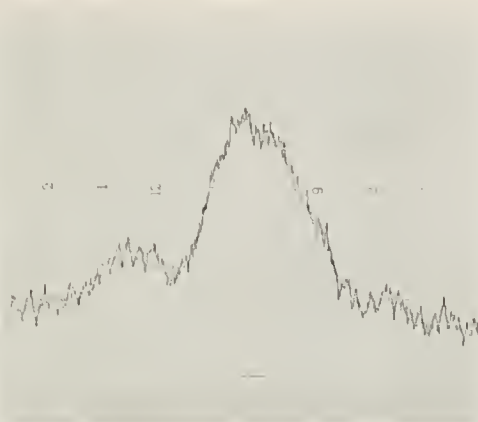

Figure 2: Photo of a chart from the University of Illinois radio telescope showing a record made as the beam swept through space. The high area is a broad complex of radio sources in the constellation of Cygnus.

The pencil beam characteristic of the University's radio telescope is made possible by a combination of the geometry of the parabolic cylindrical reflector and that of the specially-designed receiving antenna array. Since the focal line of the telescope's reflector lies in the north-south direction, the received beam always lies in the meridian, or north-south, plane. This restriction means that the telescope detects a radio source only if it lies on a particular imaginary line in the sky. The imaginary line runs north and south, and extends from the northern horizon, through the zenith, to the southern horizon. This selective

property is due to the geometry of the reflector: only those groups of rays originating in the meridian plane are completely reflected to the focal-line receiving antennas. The pencil-shape characteristic is achieved by the special array of receiving antennas. The spacing of these antennas from one another and the manner in which each is connected to the receiver are important in receiving a narrow beam. By making the connection of each antenna to the receiver electrically correct, proper cancellations and reinforcements of the signal from each antenna occur, and the narrow beam characteristic of the telescope results. These spiral receiving antennas have provisions for rotating them on their axes. A certain angular position for each spiral antenna results in a particular signal cancellation and reinforcement at the receiving device, effectively the same as that mentioned previously. By rotating each of the 276 spiral antennas to its proper position, the received beam can be moved in the meridian plane thirty degrees either side of the zenith. West-to-east motion of the beam in the sky is achieved by purely natural means: rotation of the earth on its axis. Utilizing this rotation, the University of Illinois radio telescope can "paint" a complete circle of coverage of the sky in twenty-four hours. During the survey, the radio astronomy staff will change the angle in the meridian plane a small amount each day by adjusting the receiving antennas and eventually will get an accumulative coverage thirty degrees north and south of the zenith.

(Continued on Page 29, Column 1)

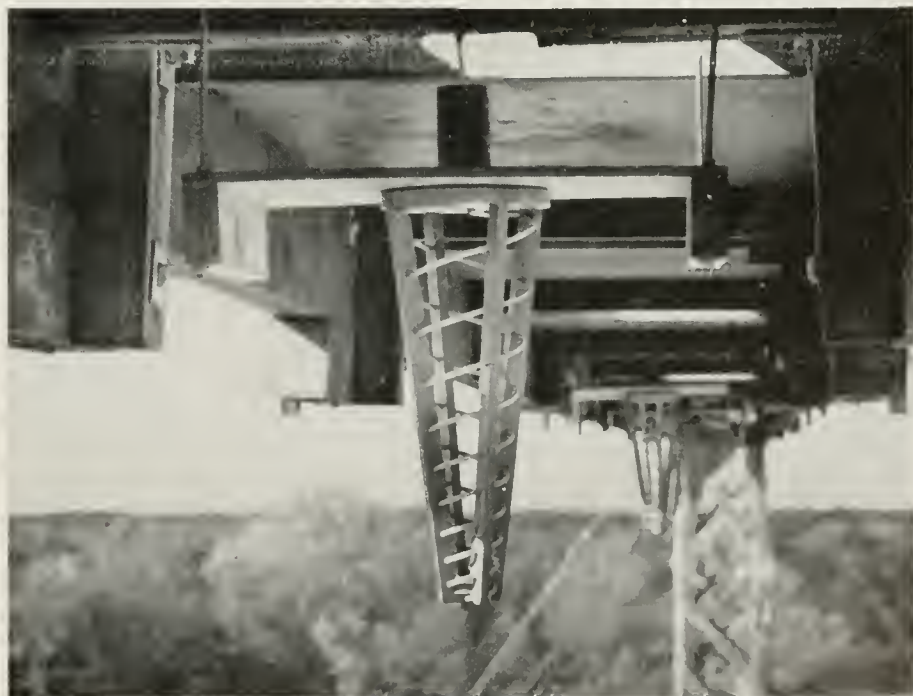

Figure 3: A view from underneath the catwalk of one of the logarithmic-spiral antennas.

# THE PROFESSIONAL ENGINEERING REFRESHER COURSE

by Dean H. L. Wakeland

Nearly any day you visit the University of Illinois Willard Airport, you see university staff members either departing for or arriving from some community in Illinois. Most of these staff members are teaching some type of an extension course. Air travel has made it possible to conveniently reach even the remotest of areas in Illinois, and to offer various types of college class work in all communities.

However, all of the extension offerings of the university are not in the form of undergraduate or graduate class work, but are types of instruction which provide only a service rather than credit to the people of the state. One of the larger of these programs is the offering of the Professional Engineering Refresher Course, which is a joint program of the extension division and the College of Engineering. From fifteen to twenty engineering staff members share in the instruction of this course each semester, which is offered in a number of localities in Illinois. The Professional Engineering Refresher Course is a series of organized lectures to aid graduate engineers in preparing for the State of Illinois Professional Engineering Examination. Illinois, as does most other states, stipulates that to practice, or offer to practice, professional engineering, a person must be registered as a Professional Engineer according to the Illinois Professional Engineering Act. To become legally registered, an engineer must have at least four years of engineering experience and pass a state examination to prove his ability as an engineer.

Many students leave engineering colleges each year without being aware of the responsibility of legal registration or the manner in which to become registered. Thus, the University of Illinois has offered the Professional Engineering Refresher Course, at the suggestion of the Illinois Society of Professional Engineers, to encourage and prepare graduate engineers to become registered and also to aid them in their professional growth.

The course consists of a series of lectures covering the basic principles and fundamentals of engineering. It is expected that students enrolled will already have received engineering degrees, and thus the lectures are designed primarily as a review of earlier studies.

The Professional Engineering Examination is usually given each May and November, and the Refresher Course is scheduled in a manner to prepare for these dates. During the fall semester the refresher course is normally offered in Arlington Heights, LaGrange, Elmhurst, Springfield, Chicago, Blue Island, Rockford, Decatur, and Urbana. And in the spring, in LaGrange, Park Ridge, Ottawa, Elgin, East St. Louis, Mt. Vernon, Chicago, Effingham, Moline, and Rockford. In some of these localities several sections are offered at the same time, and sections usually have about 30 students. The course cost is \$30.00, but the engineer's employer often pays the tuition fee to encourage his registration as an engineer. It certainly is not mandatory that a graduate engineer take the refresher course before he writes the Professional Engineering Examination, but the series of lectures are most helpful in guiding preparation. If a graduate engineer is located in a state other than Illinois, similar review courses are offered either by state universities or interested engineering groups. In Illinois, additional review courses are offered by other universities in Peoria and Chicago.

The examination in the State of Illinois is offered in two parts, and the first day of examination is concerned primarily with the theory in fundamental areas, such as statics, dynamics, hydraulics, mathematics, strength of materials, economics, and electricity. The second day of the examination is designed to test the engineer in applied types of engineering problems where judgment and evaluation of the problem are as important as the correct theoretical solution. The second portion of the examination may not be taken until after the engineer has had 4 years of experience, but the first portion may be taken at any time during the last half of the senior year or after graduation. Seniors are encouraged to take the first portion of the examination during their last semester in school, at a time when theoretical concepts are still fresh in their minds. Normally, the first day of the examination is offered on the campus to encourage seniors to become registered.

Several of the student engineering organizations at the University of Illinois have organized refresher courses to help seniors prepare for the first day examina-

tion. Usually a minor charge is made for enrollment in these review periods, and the lectures are handled by staff members who are willing to assist the students. Announcements of the time, location, and cost of these sections are made in the meetings of the student engineering societies.

Engineering students should take advantage of the opportunity to complete the first portion of this examination while on campus. They may do it after they are on the job, if they so desire, but the longer it is delayed, the more difficult it becomes. In any case, all graduate engineers should plan to become registered, not only to qualify them to practice the profession of engineering legally, but also to improve them professionally. After a graduate engineer has worked for four or more years, many of the engineering fundamentals have become hazy, or have been forgotten, simply because the engineer, in most cases, has specialized in a specific area and is not continually confronted with problems requiring a mastery of all fundamentals. The review serves as a stimulus to continue additional studies on their own.

After you graduate and gain four years of experience, you might wish to take the professional engineering refresher course. If so, you will be able to find out where the course is being offered in Illinois by writing the Extension Division at the University of Illinois, Urbana. However, for applications for the examination, you should write to the Department of Education and Registration, Springfield, Illinois, and they will in turn notify you of the date of the examination, requirements for registration, and other pertinent information. Seniors in the College of Engineering may obtain similar information from the Associate Dean's Office in 103 Civil Engineering Hall.

Legal registration as a Professional Engineer is going to become increasingly more important, and all students in the College of Engineering should plan to take the first step towards professional growth by writing the first half of the examination during the last half of their senior year. Then follow with the second step four years later by enrolling in a refresher course and passing the second part of the examination.



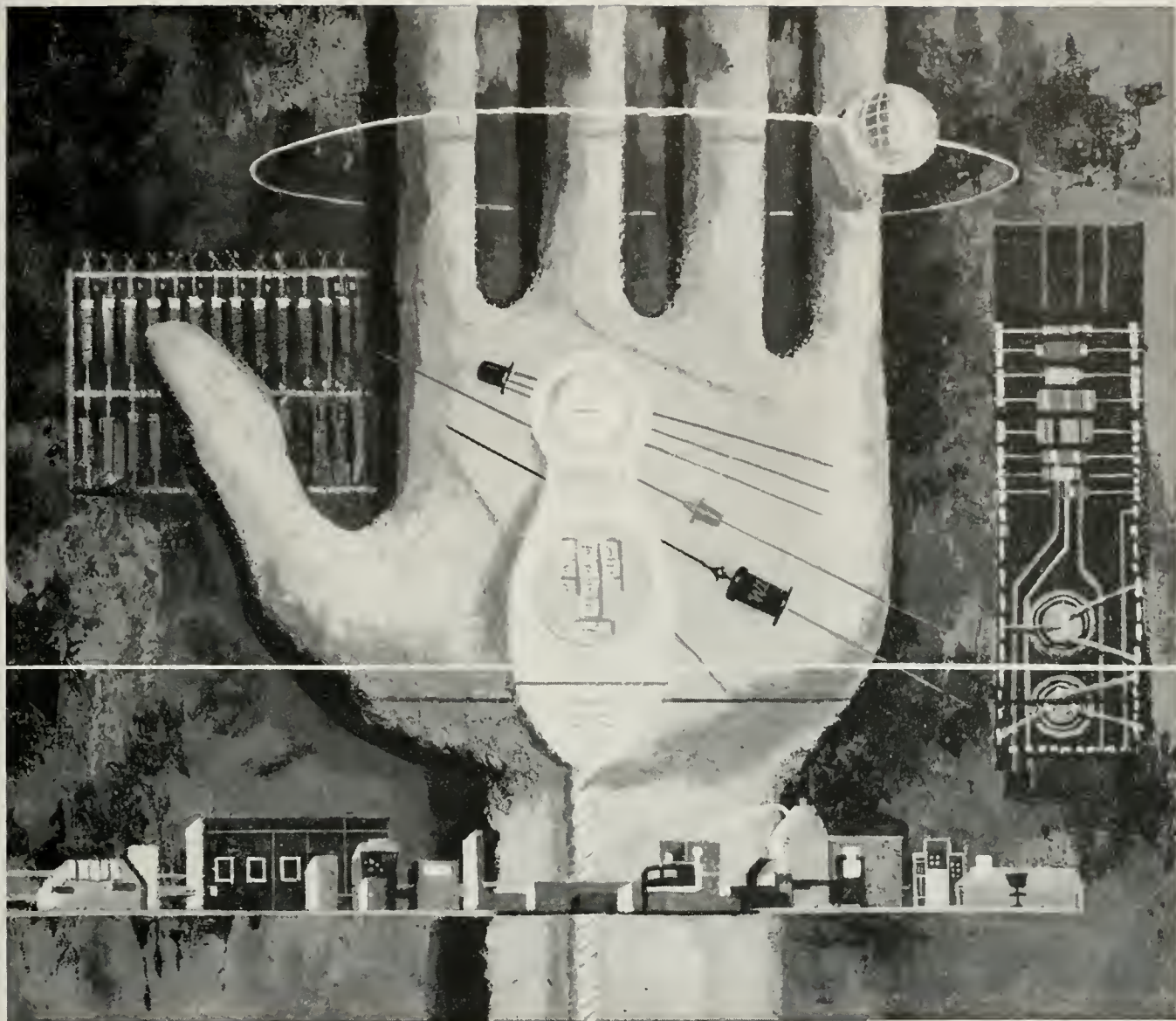

## Our future is in the hands of men not yet hired

At Western Electric we play a vital role in helping meet the complex needs of America's vast communications networks. And a career at Western Electric, the manufacturing arm of the nation-wide Bell Telephone System, offers young men the exciting opportunity to help us meet these important needs.

Today, Western Electric equipment reduces thousands of miles to fractions of seconds. Even so, we know that our present communications systems will be inadequate tomorrow; and we are seeking ways to keep up with — and anticipate — the future. For instance, right now Western Electric engineers are working on various phases of solar cell manufacture, miniaturization, data transmission, futuristic telephones, electronic central offices, and computer-controlled production lines — to name just a few.

To perfect the work now in progress and launch many new communications products, projects, procedures, and processes not yet in the mind of man — we need quality-

minded engineers. If you feel that you can meet our standards, consider the opportunities offered by working with our company. In a few short years, *you will be* Western Electric.

Challenging opportunities exist now at Western Electric for electrical, mechanical, industrial, and chemical engineers, as well as physical science, liberal arts, and business majors. All qualified applicants will receive careful consideration for employment without regard to race, creed, color or national origin. For more information about Western Electric, write College Relations, Western Electric Company, Room 6205, 222 Broadway, New York 38, New York. And be sure to arrange for a Western Electric interview when our college representatives visit your campus.



Principal manufacturing locations at Chicago, Ill.; Kearny, N. J.; Baltimore, Md.; Indianapolis, Ind.; Allentown and Laureldale, Pa.; Winston-Salem, N. C.; Buffalo, N. Y.; North Andover, Mass.; Omaha, Neb.; Kansas City, Mo.; Columbus, Ohio; Oklahoma City, Okla. Engineering Research Center, Princeton, N. J. Teletype Corporation, Skokie, Ill., and Little Rock, Ark. Also Western Electric distribution centers in 33 cities and installation headquarters in 16 cities. General headquarters: 195 Broadway, New York 7, N. Y.

# Concrete and the New Look



The new General Offices Building of the American Baptist Convention, Valley Forge, Pa.

Architecture made news in May, 1962, at the American Institute of Architects convention when the practitioners of the most useful of arts did some public soul searching. At the meeting, many architects voiced their dissatisfaction with the uninteresting building forms which have dominated our construction scene in recent years.

The call has been sounded for greater imagination in building shapes and surfaces—curtain walls, roofs and building frames—and for greater utilization of the technological advances that have been made in construction materials and methods. In both of these areas concrete has been a leader. Multiplanar curtain wall panels; curved, serpentine, and geometrically shaped frames; and the fantastic shapes of shell roofs permit architects' imaginations to run practically unfettered.

An outstanding example of this new look in architecture and technology is the national office buildings of the American Baptist Convention, Valley Forge, Pa. Upon their dedication in May, 1962, motorists traveling the Pennsylvania Turnpike near the Valley Forge exit began stopping in such numbers to view the buildings that the Turnpike Authority was compelled to erect signs forbidding stopping at that point.

Anyone who has seen the structures can readily appreciate the turnpike phenomenon for they are compellingly eye-catching. And yet there is a peaceful solidarity about them that precludes any of the crassness that is sometimes associated with the term "eye-catcher."





Modern concrete technology has freed designers of the necessity of adhering to any set group of building shapes or wall textures and designs.

In keeping with the unity of the owner's faith, the architect, Vincent G. Kling, F.A.I.A., chose the circle, traditional symbol of unity, for the general plan of the building complex. In addition to its esthetic value, the circular plan had practical advantages: it placed the several divisions of the church in closer proximity than would have been possible with more conventional plans and also permitted the Graphic Arts Building, which fans out just beyond and partially encompasses the office building, to be close to the creative departments without its concomitant noise intruding upon them.

The 240 feet inner diameter and 52 feet width of the office building provides offices free of any wedge-shaped feeling and a convenient partitioning module. The logic, both esthetic and practical, of these structures and the numerous other circular, curved or otherwise unusually shaped buildings now being built is being recognized more every day. Thanks to the moldability of concrete these new building frames are fast to erect and low in cost.

The curtain walls of the American Baptist Convention offices are also of unusual interest. These are not slick, characterless panels and mullions. The exposed translucent quartz aggregate set in a white cement matrix lends an interesting texture and sparkling surface to the facade. Again, concrete made rapid and economical production of the unusual curved panels possible.

Modern concrete technology has freed designers of the necessity of adhering to any set group of building shapes or wall textures and designs. It

has also made possible a never-before known control of concrete's physical characteristics. Now that concrete is being used for such a wide variety of architectural and engineering purposes, it is imperative that its performance be controlled in many respects—strength, workability, appearance, durability, setting time and permeability. Fortunately, concrete technology has kept pace with expanding applications. This is witnessed by improved batching and mixing equipment, better ready mix trucks, effective admixtures, quality-controlled aggregates and cements, and much greater insight, in the laboratory and in the

field, into the means of achieving the desired properties in the concrete for the job at hand.

As late as the early 1900's concrete design was largely empirical. Especially in connection with the proportioning and selection of concrete ingredients there was great ignorance and confusion. The relationship between water content and strength had not been discovered. The effects of aggregate composition, gradation, and cleanliness on concrete soundness were not known. Mixing and placing practices were unscientific. All of these factors resulted in widely varying concrete quality.

Thanks to efforts of the early concrete producers and materials manufacturers and to the work of some professional groups, a great deal of science has been mixed with the art of concrete construction.

The American Baptist offices illustrate these technological advances, in addition to modern esthetic features. For example, in casting techniques, the building members range from the cast-in-place building frames, floor and roof slabs, and footings—to precast exposed aggregate wall panels and precast double-tee roof slabs—to machine-made concrete split brick for the walls of the five core towers.

Most important, however, is the control now possible of the performance of the concrete itself. This control is effected by the knowledge and care of execution exercised in each of two areas—the design and mixing of the concrete, and the handling and placing of it at the job-site. In the cast-in-place concrete of the American Baptist offices,

*(Continued on Page 24, Column 3)*



The 240 feet inner diameter and 52 feet width of the office building provides offices free of any wedge-shaped feeling and a convenient partitioning module.



a  
message  
to  
graduating  
engineers  
and  
scientists

AT PRATT & WHITNEY AIRCRAFT...

**YOUR EYES CAN BE ON THE STAGE**

**SPECIALISTS IN POWER . . . POWER FOR PROPULSION—POWER FOR AUXILIARY SYSTEMS.  
CURRENT UTILIZATIONS INCLUDE AIRCRAFT, MISSILES, SPACE VEHICLES, MARINE AND INDUSTRIAL APPLICATIONS.**



# UT YOUR FEET MUST BE ON THE GROUND

The glamour and excitement of space age programs often obscure a fundamental fact. It is simply that farsightedness must be coupled with sound, practical, down-to-earth engineering if goals are to be attained. This is the philosophy upon which Pratt & Whitney Aircraft's position as a world leader in flight propulsion systems has been built.

Almost four decades of solid engineering achievement at Pratt & Whitney Aircraft can be credited to management's conviction that basic and applied research is essential to healthy progress. In addition to concentrated research and development efforts on advanced gas turbine and rocket engines, new and exciting effects are being explored in every field of aerospace, marine and industrial power application.

The challenge of the future is indicated by current programs. Presently Pratt & Whitney Aircraft is exploring the areas of technical knowledge in *magnetohydrodynamics . . . thermionic and thermoelectric conversions . . . hypersonic propulsion . . . fuel cells and nuclear power.*

If you have interests in common with us, if you look to the future but desire to take a down-to-earth approach to get there, investigate career opportunities at Pratt & Whitney Aircraft.

To help move tomorrow closer to today, we continually seek ambitious young engineers and scientists. Your degree? It can be a B.S., M.S. or Ph.D. in: **MECHANICAL • AERONAUTICAL • ELECTRICAL • CHEMICAL and NUCLEAR ENGINEERING • PHYSICS • CHEMISTRY • METALLURGY • CERAMICS • MATHEMATICS • ENGINEERING SCIENCE or APPLIED MECHANICS.** The field still broadens. The challenge grows greater. And a future of recognition and advancement may be here for you.

---

For further information regarding an engineering career at Pratt & Whitney Aircraft, consult your college placement officer or write to Mr. William L. Stoner, Engineering Department, Pratt & Whitney Aircraft, East Hartford 8, Connecticut.

---

**Pratt & Whitney Aircraft**

CONNECTICUT OPERATIONS EAST HARTFORD, CONNECTICUT

FLORIDA OPERATIONS WEST PALM BEACH, FLORIDA

**U**  
DIVISION OF UNITED AIRCRAFT CORP.  
**A**

An Equal Opportunity Employer

# INFORMATION RETRIEVAL

by Thelma Allen, CE '65

In the early 1950's many business concerns and professional societies began to see the need for a new system of locating information in their huge scientific libraries. Within the last decade the annual volume of technical material more than doubled, multiplying the need for a new system of information retrieval.

When administrators, scientists, and engineers began their research of the problem, they soon discovered that the old systems of cataloguing information were inefficient and resulted in expensive time losses in locating references. In most instances, an inquirer was looking for a specific topic to solve a particular problem. The Dewey Decimal System, which does not allow for new concepts and categories, failed to indicate all the topics covered in a book so that the selected material was often irrelevant. For example, a single report could cover chemistry, physics, mathematics, and economics. If the predominant subject matter were chemistry, the report would be filed under that heading. Thus a mathematician might easily have overlooked the report which contained the data needed to solve his problem.

It soon became obvious that a new system which differed from the Dewey Decimal System in that its scope would

never be exhausted by a continually expanding list of concepts was needed. The scientists and engineers of a subcommittee of the American Institute of Chemical Engineers Standards Committee (AIChE) developed a system based on the keywords in the section titles and text books allowing all the necessary cross references. The number of key words per book varies from ten to thirty. Since these keywords form a type of dictionary, new concepts can be added as needed.

The following is a brief sketch of classification under the new system. After deciding to include a publication in a collection, the first step is indexing either by titles or content. Title indexing is usually sufficient for individual libraries. In this method only the keywords in the titles are indexed. However, many individuals and business concerns prefer to index all the keywords in the printed matter. This requires an analysis of the book, identification and evaluation of the keywords, and a description which includes a short abstract and a list of the keywords. Most companies prefer to have this step followed by a dissimilation process in which computers compare profile cards of individuals and documents by the use of these

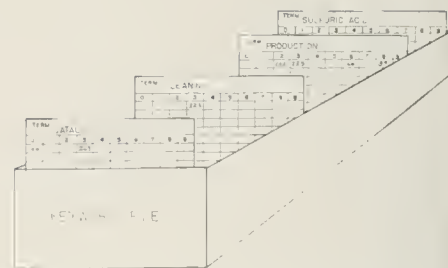

Figure 2. The proposed keyword card system.

keywords. Each employee who could possibly use the information is then sent a copy of the abstract. In this manner the retrieval problem is reduced in two ways: first, it keeps the users of the system abreast of current developments and, secondly, it reduces the number of actual retrievals because the users will have already familiarized themselves with the information.

The actual retrieval is the selection of material pertinent to a specific problem. This selection must include all relevant material, yet it must not include so much that the reader is forced to consider unnecessarily large volumes of material to find his solution.

For two years AIChE worked on this system to conserve technical manpower as well as provide efficient information retrieval. As each publication comes out, they ask the author and editor to print a list of keywords and an abstract. This eliminates the duplication involved when each of many companies has one of its employees index the book.

The subcommittee also suggested a two file system for indexing. One file contains a card for each book in the collection. These 3x5 cards are divided into four parts. (Fig. 1) At the top is a listing of keywords from that book. A short abstract occupies the center space, and a bibliography is found at the bottom. In the upper right hand corner there is an accession number. These numbers do not have to be grouped by subject matter as in the Dewey Decimal System. However, they indicate where the book can be located since all books are kept in numerical order.

In the keyword file, the cards contain the accession number of all books related to each keyword. The accession numbers are placed in ten columns according to the units' digit (Fig. 2). By placing the numbers in columns in this manner, specific topics are easier to locate. For example, to locate information on "cleaning of catalysts" a person would look for the same accession number under "cleaning" and "catalysts." It is easier to pick out a number from a

A. Liquid-1, spraying-10, drying-8, atomizing-10, gas-10, latent heat-10, radiation-10, wall-9. B. Sulfite liquor-1, sulfur dioxide-2, spraying-10, drying-8. C. Pyrites-1, roasting-10, drying-8, spraying-10. D. Uranyl nitrate-1, uranium oxide-2, denitration-10.

755

Liquids are spray dried without atomizing gas. Latent heat is supplied by direct radiation from hot wall to spray. Discloses application to production of sulfur dioxide from sulfite liquor, to roasting of pyrites, to denitration of uranyl nitrate to uranium oxide, and to oxidation of sewage sludge.

C.E.P. 56, p. 102 (January 1960).

Figure 1



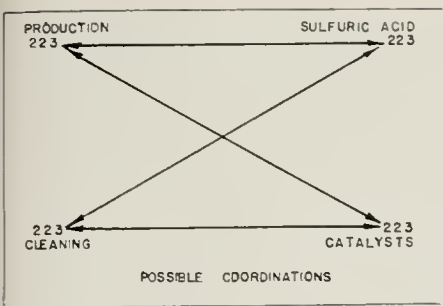

False retrievals with concept coordination.

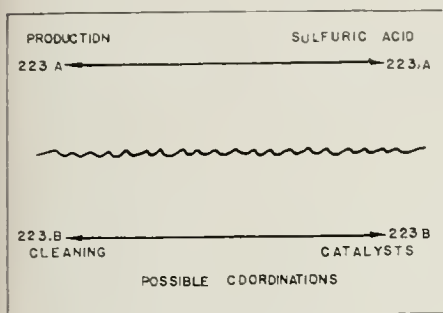

Figure 3. Use of links in concept coordination solves false retrieval.

column than from a list, especially when there are ten columns.

The keyword system has the advantage that indexing can be broken down into finer divisions than can cataloguing in the Dewey Decimal System. Since the keywords are in basic technical language rather than ideas derived from several terms, it is less likely that the catalogued units will become useless.

The AIChE also suggested using letters representing links which show the relationship of keywords to one another to further simplify the task of finding information. For example, in article 223 they keywords are "catalysts," "cleaning," "production," and "sulfuric acid." (Fig. 2) A person looking for information on "The production of catalysts" has wasted his time if he assumes "catalysts" and "production" are linked when "production" applies only to "sulfuric acid" and cleaning applies to "catalysts." Therefore, link letters are added after the accession number to eliminate false coordination. (Fig. 3).

To further aid the inquirer the AIChE suggested that numbers representing roles be placed after keywords, and that multi-keyed cards be made if more than one role number applies to a keyword. (Fig. 4) These role numbers indicate the way in which the keywords are used in the article. For example, keywords for chemicals may have been used as raw materials, catalysts, intermediates, or products. It would be useless to search for an article in the collection if it discussed sodium chloride as a product when only information on sodium chloride as a catalyst is perti-

nent. The AIChE has set up a standard list of eleven role indicators which is now in wide use. (Table 1).

To use the files a person would first look under the keywords and roles. After matching accession numbers and links under two or more keywords, he would then find the card in the catalogue file and read the abstract. From this he could tell whether or not the book would be worthwhile.

General as well as specific keywords should be included in the indexing. Four of the keywords for "Solvent Removal from Synthetic Rubbers," in which the removal of benzene, pentane, and hexane from elastomers was discussed, are "benzene," "pentane," "hexane," and "hydrocarbons."

Although firms realized the need for more efficient information retrieval, the researchers had to justify the cost of replacing the old systems and overcome two gross misconceptions that industry had formed.

To justify the expenditure involved in switching systems, research was done on the time saved in locating information and money saved in production costs. It was found that using old systems similar to the Dewey Decimal System, an inquirer spent from one to four hours looking through index reference cards and bibliographies. Often the existing categories were too general for specific inquiries, and users asked for many books which they did not use at all.

An alternate system for acquiring the information was to consult with other technical personnel. This involved at least two persons for an hour or more. On the basis of an average salary of

\$10 per hour per technical person and an average of ten retrievals per day, it was found that a company lost a minimum of \$200 per day. Another factor considered was the fact that productivity of the inquirer was found to decrease at least 25% until the information was found. If a researcher had only one project, his productivity was virtually zero. In laboratories where each person was responsible for more than one project, the decrease was less noticeable. However, this still was not the most efficient use of technical manpower.

Under any of the new systems in a library of 20,000 books equipped with computers the cost of equipment, salaries, and lost productivity was found to be less than one-tenth of the total under the old systems. Also the new systems make it easier to locate experimental reports. This reduces the amount

(Continued on Page 25, Column 1)

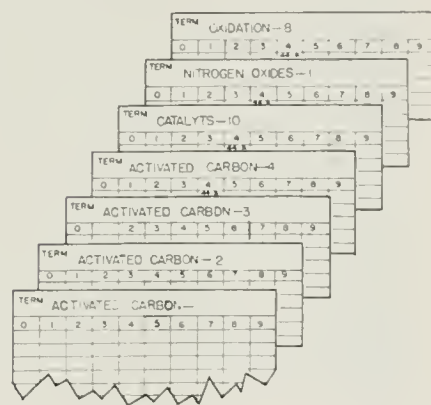

Figure 4. Cards showing role with keywords.

Table 1. Information retrieval roles.

1. Input to a change of state chemical reaction, physical production operation, electrical, or mathematical system.
  2. Product, output, by-product, co-product from the reaction, production operation, or system.
  3. Waste, contaminant, impurity.
  4. Special agent, catalyst, accelerator, stabilizer.
  5. Solvent, media, environment, support.
  6. Independent variable studied for its effect.
  7. Dependent variable studied for how it is affected.
  8. Active concept, subject of study.
  9. Passive concept, object of study.
  10. Device, material, or method for accomplishment.
- Modifiers, adjectives, proper names, companies, persons.



## *Shirley Buss*

If you think you've seen Shirley Buss, this month's blue-eyed, blonde haired Cutie, before, and you don't come from Belleville, Ill., her home town, it was probably around the Alpha Omicron Pi sorority house, her campus home. Or maybe you've seen her photo among the contestants in the Dolphin beauty contest, or even among the Homecoming Queen semifinalists. Shirley, a charter member of Guidons and stunt show director of her sorority house, is often seen enjoying some of her favorite pasttimes—reading, dancing, swimming, ice skating, tennis, and—she said it—football. This month's TECHNOCUTIE is also public relations chairlady for the Illini Union Movies. See you at the movies, men.

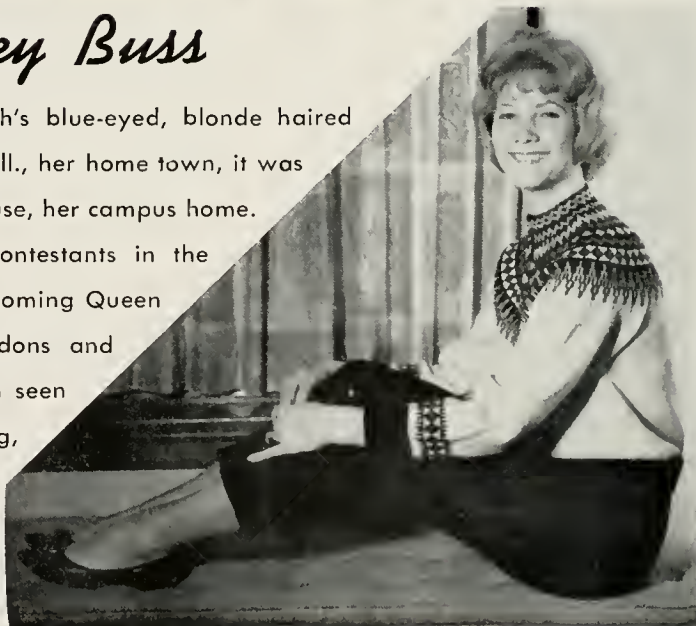





## The sky is not your limit

You're looking at an historic first — a 238,857 mile lunar bull's-eye scored by a team of scientists from Raytheon and the Massachusetts Institute of Technology, using a powerful new Raytheon-developed laser light beam. This success typifies the far-ranging variety of advanced projects challenging young engineers and scientists at Raytheon today.

For EE's, math and physics majors — in all the varied fields of engineering and science — Raytheon offers unlimited opportunity for growth and continuous advancement.

Personal career development is encouraged by a wide variety of educational assistance . . . seminars, special courses to meet individual needs and work-study programs leading to advanced degrees from renowned universities are all available.

You may well qualify for one of the exciting, career-building projects underway at Raytheon. Originality, imagination and high technical competence are your tools — the rewards are prompt and appropriate for success.

For detailed information, arrange an on-campus interview through your placement director or write G. W. Lewis, Manager of College Relations, Raytheon Company, Executive Offices, Lexington 73, Mass. An Equal Opportunity Employer.

**Raytheon offers opportunities for BS, MS and Ph.D. levels in**

- Solid State
- Microwave Electronics
- Infrared
- Lasers
- Communication & Data Processing
- Radar
- Missile Systems
- Sonar
- Electron Tube Technology

**RAYTHEON**

# NEWS AND VIEWS

at the

## University of Illinois

Edited by Gary Daymon, EE '64

### Illiac Retires After Ten Long Years

One of the fastest growing fields in the world today is computer technology. Ten years ago Illiac, a computer designed and built at the University of Illinois, was put into service. It was not only one of the world's fastest computers it was the only one at that time owned by a university. Next month it is being retired from service.

A new IBM 7090 computer, 20 times bigger in capacity than Illiac, is now available for use by U. of I. researchers. Unlike Illiac, which was sequential (computation stopped during input and output operations), the 7090 can be working on one problem while another is being put in and yet another is coming out. Input and output preparations are accomplished by a "slave" computer, an IBM 1401, which turns punched cards into magnetic tape and the magnetic tape into printing for the output—at the rate of 600 full lines per minute.

The new computer will allow much faster computation than has previously been possible at the University. A representative problem that would take fifteen years to solve by the use of nothing but pencil and paper, or 80 weeks with the aid of a desk calculator, can be solved by the 7090 in five seconds. It has 32,768 words in its main memory, which is backed up by magnetic tapes (two million words each) and a disc file (to be added later) which will hold nine million words.

This computer, as well as the new Illiac II (*Technograph* Nov. 1961), which is expected to be operational next spring, are facilities of the Digital Computer Laboratory, an interdisciplinary research facility under the U. of I. Graduate College. The Laboratory and its equipment are available for use by all departments on the campus. In addition to this service function, the Laboratory personnel engage actively in computer research, and there is a graduate training program associated with each research program. Illiac will continue to be used, to a limited extent, in some of the internal Laboratory research work.

Illiac had a reasonably long life span for a computer. Although it was only operational for ten calendar years, it was in use substantially 24 hours a day—that's thirty years of work, which is usually considered sufficient for retirement in anybody's book.

### Summer Institute in Engineering Technology

The third annual Summer Institute in Engineering Technology for junior college and technical institute teachers will be conducted June 17 to August 10 at the University of Illinois. Prof. Jerry S. Dobrovolny, head of the Department of General Engineering is director of the eight-week summer institute.

Forty teachers throughout the country will be selected. Each teacher will receive a \$600 fellowship plus allowances for dependents and travel. No tuition will be charged, and housing will be available in the U. of I.'s residence halls.

Courses will be offered in engineering mathematics, electronics technology, and machine design technology. Those attending will also take part in technical education seminars, and may obtain credit towards a graduate degree. The application deadline is February 15.

### Dr. Bailar Receives \$91,400 Research Grant

Dr. J. G. Bailar Jr., an internationally known University of Illinois chemist, has received a \$91,400 three-year research grant from the National Science Foundation. Dr. Bailar will use the grant to study the reactions of complexes in inorganic chemistry, a field which he pioneered 30 years ago.

Today's applications of inorganic complex compounds include medicines, insect repellants, plant growth regulators, and dyes. Other products for industrial processes such as improved rubber, plastics, greases and lubricants are being used exclusively.

Among chemical problems which Dr. Bailar now is studying are inorganic polymers and the possibility of linking metallic atoms into their molecular chains. His research, if successful, will open the way to plastics and liquids which can withstand extremely high temperatures and serve special uses, particularly in space applications.

Dr. Bailar has been president of the American Chemical Society, and 65 chemists have received doctorate degrees under him during the last three decades.

### Lubricants for Space Travel

Lubricants for space travel and exploration are being studied by the University of Illinois Department of Ceramic Engineering under a \$35,000 contract with the Aeronautical Systems Division of Wright-Patterson Air Force Base, Dayton, Ohio.

One lubricant is desired which will function under a variety of conditions in high and low temperatures (80 to 1500°F.), in a vacuum and in high radioactive areas. The project includes the study of ceramic bonding materials for dry film lubricants and the relationship of binder, lubricant and metal. It also includes the investigation of chemical stability and physical properties.

The project is headed by Prof. J. A. Nelson, with H. R. Thornton and J. F. Benzel acting as research assistants.

### Maybe They'll Even Change The River's Name

Thousands of acres of southern Illinois land which had been periodically flooded in the past will soon be flood-free. The land lies in the Big Muddy River Basin, and the cure for the problem, the Rend Lake Dam and Reservoir, will be constructed on the river near Benton, Illinois. University of Illinois Hydraulic Engineering students and staff members have been studying many phases of the project for the last several years.

The University of Illinois studies on the Rend Lake Project started in 1957. U. of I. hydraulic engineering classes, working with the Illinois Division of Waterways and the Rend Lake Conservation District, constructed models of proposed spillways as part of their regular classroom work. This procedure, which provided the students with an opportunity to work on a real project under active development, has made a major contribution to the initial planning of the spillway section and various modifications which have been proposed for the structure. The project has now reached the stage of study and analysis by appropriate state agencies, consulting engineers, and other people concerned with reservoir development in Illinois.

The University of Illinois work on the project, directed by John C. Guillou, Professor of Hydraulic Engineering, also involved studies of bottomland reclamation of areas which will be free of flooding after the dam is completed, and of the most economical methods of reclaiming the land which has previously been flooded. This work, according to Professor Guillou, has been an example of the sort of project which provides valuable experience for the students and, at the same time, a real service for the people of the state.





## Splitting atoms . . . under control

Inside a nuclear reactor, atoms are split by nuclear "bullets" or neutrons flying at 5000 miles per hour. Vast amounts of energy are released. In many of today's reactors, the secret of controlling this chain reaction and putting it to work lies in a special form of carbon known as graphite. Graphite slows down the neutrons to a working speed and keeps them within the reactor core where they can split more atoms to generate useful heat. ► And the hotter the better, because graphite grows even stronger at high temperatures! That's why graphite is also used inside rocket and missile engines to withstand the searing blast of burning fuels . . . and on nose cones and other critical surfaces to protect against the intense heat caused by air friction. ► Under the trademark NATIONAL, Union Carbide has been making carbon and graphite increasingly useful to industry for more than fifty years. It is only one example of how the people of Union Carbide are constantly striving for a better tomorrow.

A HAND IN THINGS TO COME

WRITE for booklet C-60 "The Exciting Universe of Union Carbide", which tells how research in the fields of carbons, chemicals, gases, metals, plastics and nuclear energy keeps bringing new wonders into your life. Union Carbide Corporation, 270 Park Avenue, New York 17, N.Y. In Canada, Union Carbide Canada Limited, Toronto.

**UNION  
CARBIDE**



## AN OPPORTUNITY TO GROW IN THE HIGHEST PROFESSIONAL WORKING ENVIRONMENT...

MITRE designs and develops systems that enable our military commanders to detect attack and retaliate instantly. Typical systems include Nuclear Detection and Reporting Systems, North American Air Defense Combat Operations Center and Back Up Interceptor Control System. MITRE is also experimenting with techniques for future air traffic control systems.

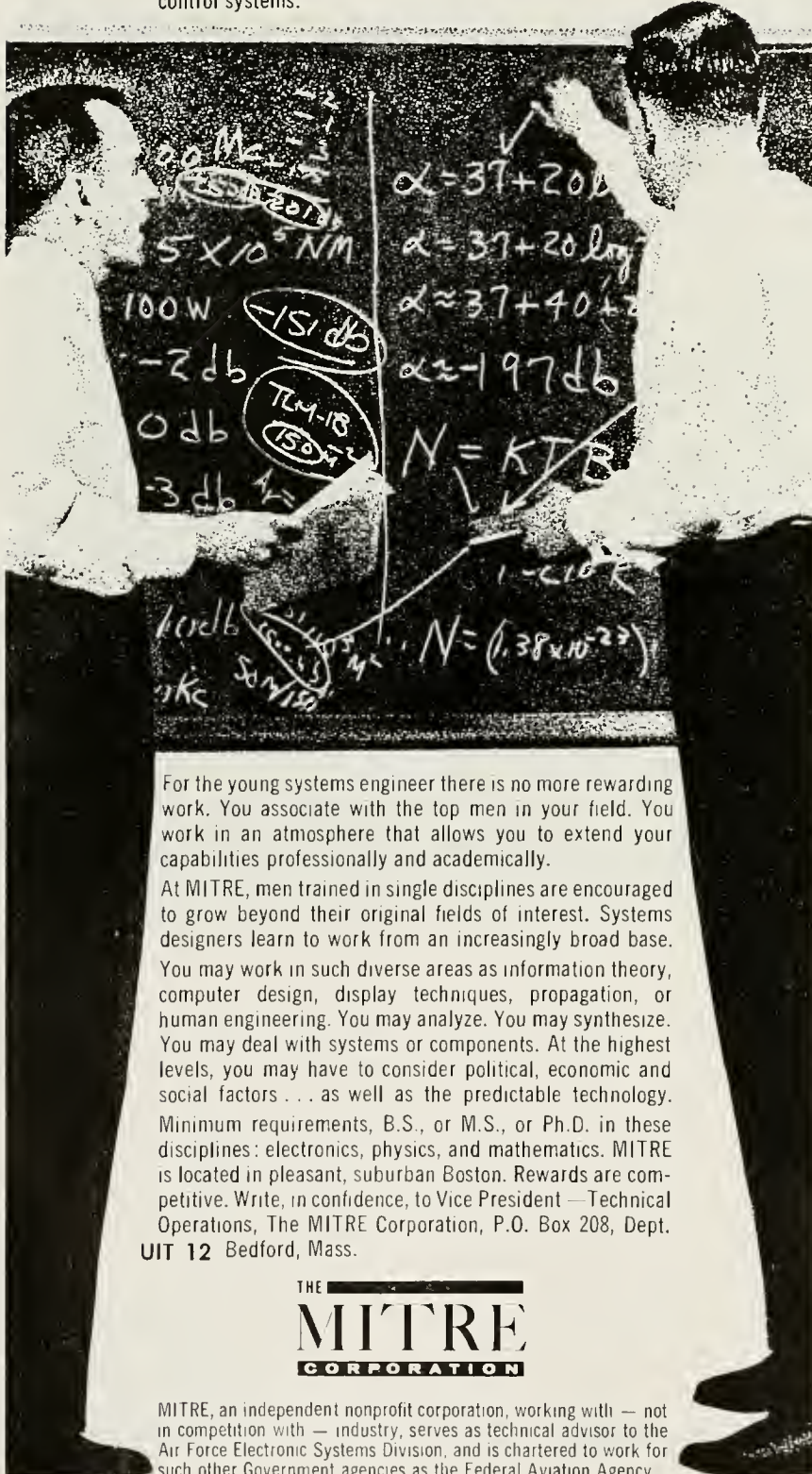

For the young systems engineer there is no more rewarding work. You associate with the top men in your field. You work in an atmosphere that allows you to extend your capabilities professionally and academically.

At MITRE, men trained in single disciplines are encouraged to grow beyond their original fields of interest. Systems designers learn to work from an increasingly broad base.

You may work in such diverse areas as information theory, computer design, display techniques, propagation, or human engineering. You may analyze. You may synthesize. You may deal with systems or components. At the highest levels, you may have to consider political, economic and social factors... as well as the predictable technology.

Minimum requirements, B.S., or M.S., or Ph.D. in these disciplines: electronics, physics, and mathematics. MITRE is located in pleasant, suburban Boston. Rewards are competitive. Write, in confidence, to Vice President — Technical Operations, The MITRE Corporation, P.O. Box 208, Dept. UIT 12 Bedford, Mass.

THE  
**MITRE**  
CORPORATION

MITRE, an independent nonprofit corporation, working with — not in competition with — industry, serves as technical advisor to the Air Force Electronic Systems Division, and is chartered to work for such other Government agencies as the Federal Aviation Agency.

## New Look in Concrete . . .

(Continued from Page 15)

for example, two types were needed—one for the structural members (columns, beams, trusses), and another for the floor and roof slabs.

Higher stresses and greater reinforcement concentration in the structural members dictated a concrete mix that was both workable and of high strength. The resulting concrete was a 4,000 psi mix of 5-inch slump using Pozzoloth water-reducing, set controlling admixture to control slump and strength. For the floor and roof slabs a 3,000 psi mix of 4-inch slump was specified using the following materials:

Cement 480 lbs.  
Sand 1,400 lbs.  
3/4" Stone  
Pozzoloth 1.02 lbs.  
Water 34 gals.

Thanks to the high quality materials used and control exercised by the ready-mixed concrete supplier, Highway Concrete Co., the coefficient of variation was less than 10 per cent—a highly enviable record. There were 726 tests of 6 to 8 cylinders each made of the 3,000 psi concrete, and every single result exceeded the specified strength.

Of course, the performance of even the best concrete can be seriously undermined by faulty formwork, poor placing and finishing practices or inadequate curing. To illustrate the over-all excellence of the work on the American Baptist offices, the project supervisor for the general contractor, Turner Construction Co., commented on the concrete in place, "Probably the best controlled concrete—from the standpoint of slump and everything else—I've ever seen. Honeycomb on this job was unknown. We just didn't have it."

By a fortunate set of developments, maturity in concrete control—quality materials, improved ready-mix equipment, enlightened handling and placing practices—and the new trend in architecture—freer building forms, greater variety in texture and color—have occurred simultaneously. The result is that the logical construction material for the new architecture is ready for the challenge.

Vincent G. Kling put it well when he said, "Concrete was chosen as the basic material for the American Baptist offices because of its permanence and high fire rating and because it can be moulded freely to any contour and shape. As utilized in many forms and techniques throughout the project, it presents one of the most complete examples yet of the versatility of modern concrete technology."

(Printed by permission of The Masters Builders Company, a division of American-Marietta Company, Bruce R. Wellek, Asst. Dir. P.R. Dept.) ♦♦♦



of money wasted on duplicating experiments. Also time is saved in developing a product because it is easier and quicker to use the new system than to experiment to find out if a new process is workable.

The misconception that the new system was more difficult to comprehend than the Theory of Relativity was based upon the advanced standing of the scientists who first called the attention to the problem, the immensity of the problem, the impressive calibre of engineers prominent in finding the solution, and the very fields concerned. In attempting to dispel this misconception the promoters gave the impression that the system was very simple.

There were three ways in which the process was oversimplified in some administrators' minds. Some thought retrieval as the whole story—problem, solution, Q.E.D.; others believed that information handling was the same as data handling; the third group thought that information retrieval was on a dehumanized plateau of advanced electronics where all answers were at some button-pusher's fingertips. Today the new systems are generally accepted by industry and individuals alike for use in libraries. ♦♦♦

### Pictures With Ultra-Violet Light

A new paper which copies engineering drawings by exposure to ultra-violet light was introduced by Copymation, Inc., of Chicago. Called "UV-Dri," it develops into a sharp permanent image without processing by liquid chemicals, gases, or heat. UV-Dri's special coating reacts to ultra-violet light shining through transparent or translucent originals of engineering drawings. Dark lines on originals show up white on UV-Dri—a reversal process as in fingerprints. This paper will initially be sold in a blue color. Other colors successfully produced so far in laboratory tests include violet, red, and green. Finishes range from matte to high gloss.

### Research Pays Off

Experience and knowledge gained from building the power plant of the N. S. Savannah, the world's first nuclear cargo-passenger ship, have led to the development of a more powerful and compact yet less expensive marine propulsion reactor. Weighing 685 long tons or about 25% of the N. S. Savannah's reactor system, the new plant will fit into the same space as the conventional oil fired marine boilers. Engineers at Babcock & Wilcox Company predict that future cargo ships containing this reactor will attain 23 knots at an operating cost equivalent to that for conventional ships.

# ENGINEERING CALENDAR

## January

- |       |   |  |
|-------|---|--|
| 3     | Classes Resume  | 1:00 p.m.  |
| 7     | "Some Considerations in the Design and Development of Log-Periodic Antennas,"<br>Dr. P. Mayes                   | 4:00 p.m.—141 EEB                                |
|       | Preview of the papers to be presented at the Orlando, Florida, Millimeter Wave Conference                       | 3:00 p.m.—141 EEB                                |
| 8     | "Chemical Effects of Nuclear Transformations in the Gas Phase,"<br>Mrs. A. C. Wang                              | 4:00 p.m.—112 Chem Annex<br>7:30 p.m.—116 E Chem |
|       | <b>ASCE</b>   |  |
| 9     | "Delayed Creep in Iron,"<br>Prof. J. E. Weertmen  | 4:00 p.m.—218 Cer                                |
|       | <b>AIChE</b>  | 7:00 p.m.—116 E Chem                             |
|       | <b>AIIE-IRE</b>   | 7:30 p.m.—151 EEB                                |
|       | <b>AIIE</b>   | 7:00 p.m.—253 MEB                                |
|       | <b>ASME (elections)</b>   | 7:00 p.m.—to be announced                        |
|       | <b>EMS</b>  | 7:30 p.m.—220 TL                                 |
| 11    | "Kinematics of Dehydrogenation of Isopropanol,"<br>Mr. C. Q. Sheely   | 4:00 p.m.—112 Chem Annex                         |
| 14    | "Propagation Characteristics of a Transmission Line Loaded Periodically with Dipole Antennas,"<br>Dr. R. Mittra | 4:00 p.m.—141 EEB                                |
| 15    | "Recent Chemistry of the Alene,"<br>Mr. P. D. Eyman   | 4:00 p.m.—112 Chem Annex                         |
| 16    | Study Day   |  |
|       | "Yielding of Iron,"<br>Dr. R. M. Fisher   | 4:00 p.m.—218 Cer                                |
| 17-25 | Finals, Good Luck!  |  |
| 23    | "Electronmicroscopic Observations of Martensite Formation in Cu-Al Alloys,"<br>Mr. P. R. Swann                  | 4:00 p.m.—218 Cer                                |
| 29-30 | Fifth Sanitary Engineering Conference, "Quality Aspects of Water Distribution Systems"                          |  |

*Opportunities are better than  
ever at Bethlehem Steel!*

## The Bethlehem Loop Course

... and how it works

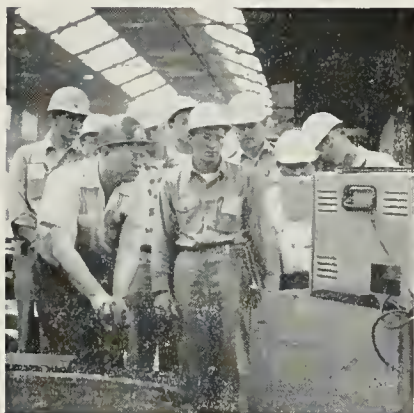

The Loop Course is our continuing program for selecting and training qualified college graduates for careers with Bethlehem Steel. It was established some forty years ago. Its unusual name comes from the fact that from the very beginning, the course has included an observational circuit (or "loop") of a steel plant.

### Promotion from Within

The Loop Course provides management personnel. Since it is our policy to promote from within, it is vital that competent men, well-grounded in our practices and policies, be available to fill management openings as they occur. And, due to Bethlehem's steady and continuing growth, there has been no lack of opportunities to advance.

### The Basic Course

Every looper attends the initial five-week course held at our home

office in Bethlehem, Pa., beginning early in July. He attends orientation talks, listens to discussions by management men on all phases of company operations, and makes daily trips through the local steel plant. At the end of this period he has a sound knowledge of the overall Bethlehem organization.

### Their First Assignments

At the end of the basic course, loopers receive their first assignments. Ordinarily a large majority report to our steelmaking plants, where they attend orientation programs much like the initial one at Bethlehem. During this period, plant management closely observes each looper's aptitudes and interests, with the objective of giving him an assignment for which he appears to be best fitted, and corresponding as closely as possible to his interests, educational background, and work preferences. Loopers selected for sales, research, fabricated steel construction, mining, shipbuilding, and the company's administrative departments, proceed from the basic course to specialized training programs.

### Preparing for Advancement

As the looper gains in ability, experience, and knowledge, and as openings occur, he is moved into positions of increasingly greater responsibility. The company expects and encourages the looper to produce... to make steady prog-

ress. Regular reports on his work and progress are made to department heads—and annual reports to divisional vice-presidents—throughout his career.

### Emphasis on Technical Degrees

Because of the nature of Bethlehem's activities, the greatest demand is for men with technical degrees, especially those in chemical, civil, electrical, industrial, mechanical, metallurgical, mining, and naval architecture and marine engineering.

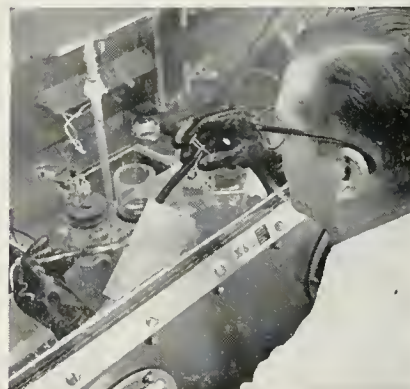

### Read Our Booklet

The eligibility requirements for the Loop Course, as well as how it operates, are more fully covered in our booklet, "Careers with Bethlehem Steel and the Loop Course." Copies are available in most college placement offices, or may be obtained by writing to Manager of Personnel, Bethlehem Steel Company, Bethlehem, Pa.

*An equal opportunity employer*



**BETHLEHEM STEEL**





Looking towards a Ch.E., E.E., M.E. or Chemistry degree?



Look ahead to the advantages of a career in Monsanto production



Let's face it. Production is the very heart of a billion-dollar *producer* like Monsanto. Here's where the young engineer meets technical challenges second to none. Here's where he can display his talents daily... helping increase yields, improve processes, raise efficiency, lower costs, boost profits. Here's where Monsanto's on-the-job training can help him move ahead faster... personally and professionally.

Monsanto production men are known by many titles—Maintenance Staff Engineer, Plant Tech-

nical Services Engineer, Production Supervisor... to name a few. Try one on for size *now*... then see your Placement Director to arrange an interview when we visit your campus soon. Or write for our new brochure, "You, Your Career and Monsanto," to Professional Employment Manager, Department EM-6, Monsanto Chemical Company, St. Louis 66, Missouri.

All qualified applicants will receive consideration without regard to race, creed, color or national origin.



A basic problem facing the designers of submersible, sea-going, air-cushion, flying or space-seeking vehicles is the resistance of the liquid or gaseous fluids through which these craft must pass. The shape of the vehicle becomes critical in determining its speed and efficiency. Research on fluid dynamic shapes at Douglas Aircraft Division laboratories is among the most advanced in the world. Included are studies and experimental work relating to submarines,

## THE SHAPE OF SPEED

...A STIMULATING AREA FOR CREATIVE ENGINEERS

ships, subsonic, supersonic and hypersonic aircraft, and manned re-entry space-planes.

Also under present development are new computer-oriented methods of calculating the potential flow and heat about arbitrary bodies throughout the speed spectrum and solving the various configuration problems which are involved.

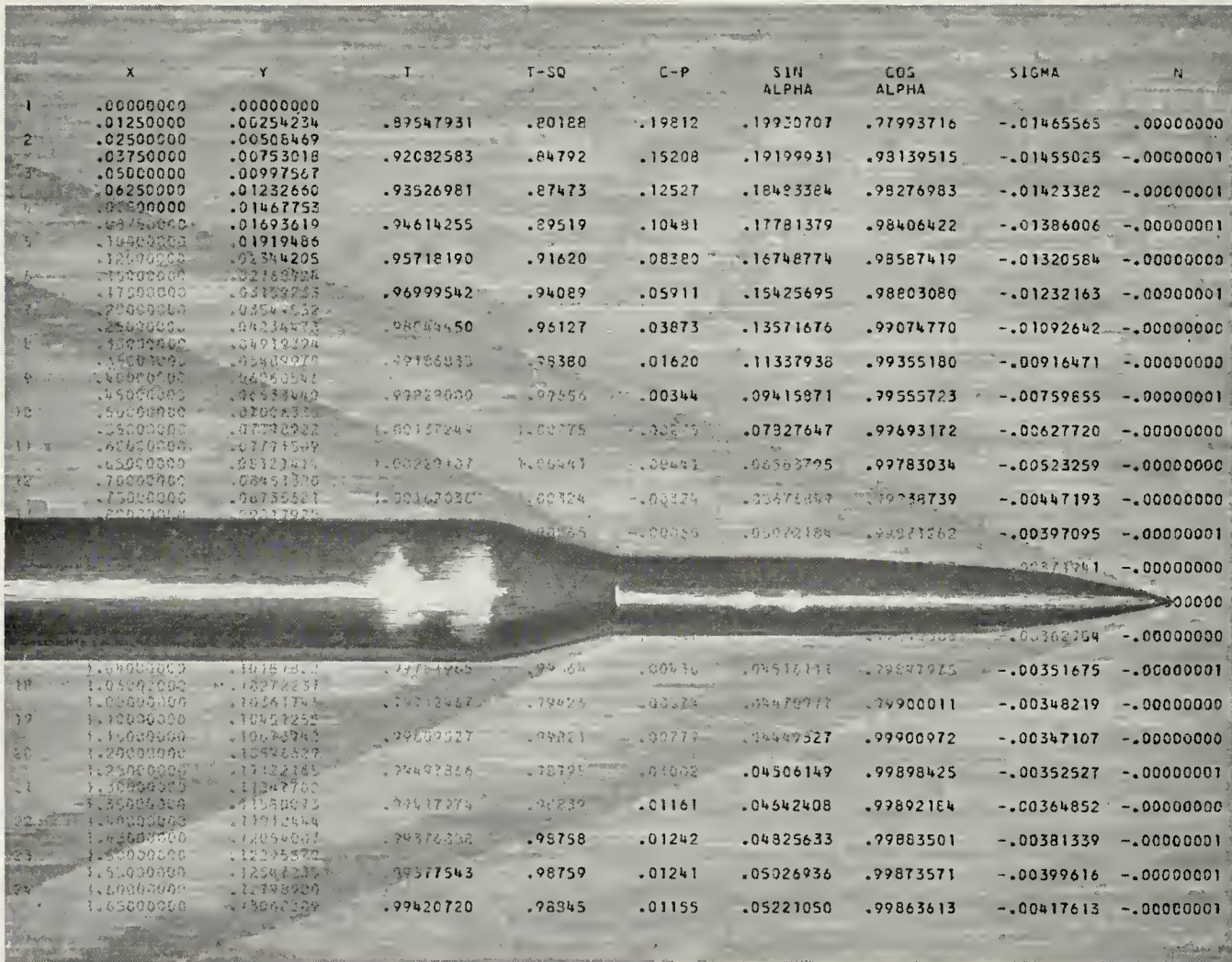

The above is only one of hundreds of interesting assignment areas at Douglas. If you are seeking a stimulating career with an organization in the thick of the most vital programs of today and tomorrow, we invite you to contact us. Write to Mr. S. A. Amestoy, Douglas Aircraft Company, 3000 Ocean Park Boulevard, Santa Monica, California. Box 600-M. Douglas is an equal opportunity employer.





## Radio Telescope . . .

(Continued from Page 11)

### Receiving Antenna Array

The receiving antenna array is mounted along the focal line of the reflector. The array consists of 276 conical, logarithmic-spiral antennas which were developed in the U. of I. Antenna Laboratory by Dr. J. D. Dyson. These antennas are placed in "pointing-down" position underneath the focal-line catwalk. A close-up of a spiral antenna in position is shown in Fig. 3. The spiral antennas are not uniformly spaced along the focal line of the reflector. Most are placed toward the center of the focal line. The array or arrangement of the antennas was designed by Dr. Y. T. Lo, who is also of the Antenna Laboratory. Dr. Lo's array helps produce the telescope's narrow beamwidth, as we have seen before.

### Construction

The telescope is located forty miles from campus, five miles southeast of Danville at the University's Vermilion River Observatory. The Observatory and its telescope were located here so that designers could take advantage of a natural ravine cut out by a small tributary stream to the Vermilion River. If the reflector's earth base were to have been dug in level ground, at least 150,-

000 cubic yards of earth would have had to been removed. By the use of the natural depression of the ravine, only 50,000 cubic yards were required to be moved in a balanced cut-and-fill operation. The original stream now runs through a concrete channel in the center of the reflector with a two per cent, downstream slope to the south. The reflector surface is accurate within 1.2 inches. It is covered with sealed asphalt sheets. Over these is placed a two-inch wire mesh which actually does the reflecting.

The receiving array is located on a wooden truss, 425 feet long, which forms the catwalk. The truss is supported by four wooden towers 153 feet high. (153 feet is the focal length of the reflector.) The truss and towers are made of laminated, glued fir treated with a preservative. Many of the bolts used in the towers are made of wood. The bolts' specified length turned out to be about one wavelength; had metal bolts been used, their electrical resonant frequency would have been equal to the frequency of the received signals. The resulting small induced currents in the bolts would have altered the beam shape.

The Office of Naval Research provided \$741,000 of the telescope's total \$871,640 cost. \$25,900 was contributed

by the National Science Foundation, and the remaining \$104,740 was paid by the University. The ONR is currently helping finance other radio telescope-projects at Cornell, Michigan, California, and California Institute of Technology.

### Conclusion

Radio astronomy is a rapidly growing science; the University's radio telescope will surely make significant contributions to this science in the years to come, one of which will be the training of students. Just as nuclear physics grew from a pure science to an engineering field, radio astronomy may someday do the same.

(The author wishes to thank Mr. Gary Goodman of the Astronomy Department for answering many questions relating to the telescope's operation.) ♦

### Computer-Controlled Borer

To gain precision in drilling materials, a numerically controlled jig borer is directed by an IBM computer punched tape. This new computer language, called "Autospot," is used to write a program which enables the computer to generate the tool instructions in a fraction of the time required to operate them manually.



## CIVIL ENGINEERS:

Prepare for your future in highway engineering—get the facts about new **DEEP-STRENGTH (Asphalt-Base) pavement**

With today's "giant step forward" in pavement engineering—DEEP-STRENGTH (Asphalt-Base) pavement—there is need for engineers with a solid background in the fundamentals of Asphalt technology and pavement construction.

Because new DEEP-STRENGTH Asphalt-base construction provides the most durable, most economical pavement modern engineering science has developed, Interstate and primary superhighways in all parts of the country are being built with advanced design DEEP-STRENGTH Asphalt pavement.

Already, more than 90% of America's paved roads and streets are surfaced with Asphalt. And Asphalt pavements have successfully kept America's wheels rolling since 1876.

Your contribution—and reward—in our nation's vast road-building program can depend on **your** knowledge of modern Asphalt technology. So, prepare for your future **now**. Write for your free "Student Kit" about Asphalt technology.

**The Asphalt Institute**

College Park,  
Maryland

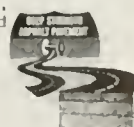

*Assignment: build  
the "grease gun"  
into our cars*



**We went to the mountain to  
make 1963 Ford-built cars  
go 30,000 to 100,000  
miles between major  
chassis lubrications**

Quite a task faced Ford Motor Company engineers when they set out to eliminate the traditional trip to the grease rack every 1,000 miles.

Like Mohammed, they went to the mountain—Bartlett Mountain on the Continental Divide in Colorado. More molybdenite is mined there than in the rest of the world combined. And from molybdenite ore comes the amazing "moly" grease that helps extend the chassis lubrication intervals for Ford-built cars. This grease sticks tenaciously to metal, stands up under extreme pressures and resists moisture, pounding and squeezing. It is slicker than skates on ice!

New, improved seals were developed. Bushings, bearings and washers of many materials were investigated. Slippery synthetics, like nylon and teflon, were used a number of new ways.

The search for means to extend chassis lubrication also led to New Orleans—where experimental suspension ball joints tested in taxicabs in regular service went two years without relubrication.

It took time. And ingenuity. But the effort paid off when Ford-built cars were the first to build in chassis lubrication good for 30,000 miles or two years—whichever came first.

Another assignment completed—another "Ford First" and another example of how Ford Motor Company provides engineering leadership for the American Road.



**MOTOR COMPANY**

The American Road, Dearborn, Michigan

**PRODUCTS FOR THE AMERICAN ROAD • THE HOME  
THE FARM • INDUSTRY • AND THE AGE OF SPACE**



# Enrolled at Dynamic TULANE



**MEN'S DORMITORY.** MAIN ARCHITECTS: *Diboll-Kessels and Richard Koch; S. Wilson, Jr. & Associates.* GENERAL CONTRACTOR: *Farnsworth & Chambers.* MECHANICAL CONTRACTOR: *Cabirac Mechanical Contractors, Inc.* CONSULTING ENGINEERS: *Jos. E. Leininger & Associates.*

## JENKINS VALVES

for long-range dependability,  
long-time maintenance economy

"Dynamic" is the word for tradition-laden, prestige-rich, 127-year-old Tulane University in New Orleans.

Nowhere is Tulane's dynamism more remarkable and articulate than in its current building program.\* Examples: the three brand new, beautiful and beautifully functional structures pictured here.

If you toured these buildings and the power plant which serves the campus complex, again and again and again you'd see the distinctive Diamond-mark that identifies Jenkins Valves. And small wonder: a university which had its beginnings more than a century ago just naturally thinks in terms of long-range dependability, long-time maintenance economy . . . precisely the qualities which make Jenkins Valves the "Standard of Quality" by which other valves are measured! Yet — and this fact still comes as a pleasant surprise to some specifiers — *they cost no more!* Jenkins Bros., 100 Park Ave., New York 17.

\*Tulane's supervisory and liaison personnel for the building program: Harold E. Pique, Director of Planning; George F. Johnson, Director of Physical Plant; Charles E. Gilbert, Utilities Superintendent.



**APARTMENT BUILDING** for married students. MAIN ARCHITECTS: *Goldstein, Parham & Labouisse.* GENERAL CONTRACTOR: *J. A. Jones Construction Co.* MECHANICAL CONTRACTOR: *Sciambra & Masino.* PLUMBING CONTRACTOR: *Jas. F. O'Neil Co., Inc.* CONSULTING ENGINEERS: *Design Engineers & Associates.*



**UNIVERSITY CENTER** features swimming pool, bowling lanes, radio station, cafeteria, ballroom. MAIN ARCHITECTS: *Curtis & Davis and Associates; Edward Silverstein.* GENERAL CONTRACTOR: *Farnsworth & Chambers.* MECHANICAL CONTRACTOR: *Sciambra & Masino.* CONSULTING ENGINEERS: *Leo S. Weil; Walter B. Moses.*

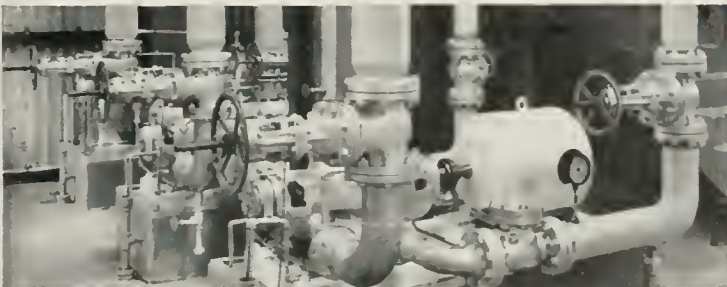

**POWER PLANT.** Boiler feed water pumps and Jenkins Valves shown. MAIN ARCHITECTS: *Paul Charbonnet, Jr.* GENERAL CONTRACTOR: *Gervais Fayrol Co.* MECHANICAL & PLUMBING CONTRACTOR: *Comfortaire Co., Inc.* CONSULTING ENGINEERS: *Leo S. Weil; Walter B. Moses.*

**JENKINS**  
MOST TRUSTED TRADEMARK IN THE VALVE WORLD  
**VALVES**



Available From Leading Distributors Everywhere

# Technoquips

An E.E. professor eyed the class as he prepared to return a batch of exam papers. "You will remain seated while they are passed out," he commanded. "If you were to stand, it is conceivable that you might accidentally form a circle. That would make me liable for arrest."

"Why?" the EE's wanted to know.

"I could be arrested for maintaining a dope ring."

\* \* \*

"Did you hear about the wreck?"

"No."

"Yeah, four professors and one student were killed."

"Poor fellow."

\* \* \*

According to a story going around Western Europe, one Prague resident refused to join the outcry against a new Khrushchev statue in the city's public square.

"Why not a statue?" he said. "It gives us shade in the summer, shelter in the winter, and an opportunity for the birds to speak for us all."

\* \* \*

A ROTC officer approached the young man in a neatly fitting uniform and asked, "What is the eighth general order?"

"I don't know," the fellow admitted.

"Have you ever been out for drill?"

"Nope."

"Don't you know enough to say 'sir' either? What outfit are you in?"

"Me? I'm the Coca Cola man."

\* \* \*

An engineer of a large instrument company was looking over drawings and specifications for a new instrument which had been ordered by one of the firm's largest clients. Attached to the paper were the coded instructions, "MHLTDD-41." Not being familiar with these designations the engineer looked in his technical journals, but was unable to find them. Finally he placed a long distance call to the customer.

"Would you mind telling me what 'MHLTDD-41' means?" he asked.

"Sure, I'll tell you," the customer said. "It means, 'Make it like the damned drawing for once.'"

A rich old lady was paying her nephew's college bills and her visitor asked her if they were expensive.

"Well," exclaimed the woman, "languages run pretty high. My check this month covered ten dollars for English, twenty dollars for French and one-hundred and fifty dollars for Scotch."

\* \* \*

Patient (to beautiful nurse): I'm in love with you. I don't want to get well."

Nurse: "You won't. The doctor saw you kissing me and he's in love with me too."

\* \* \*

If all the students who sleep in class were laid end to end, they would be more comfortable.

\* \* \*

Hold on to your hats! It seems that these three Indian squaws all liked to sleep on different kinds of skin. The first slept on buffalo skin. The second preferred deer skin. The third, hippopotamus. As time passed, the first one had a daughter, the second had a son, and the third had twins.

The moral is this: The squaw on the hippopotamus is equal to the sum of the squaws on the other two hides.

\* \* \*

Date: "You remind me of the ocean."  
E.E.: "You mean I'm wild, romantic, and restless?"

Date: "No, you make me sick."

\* \* \*

Co-ed: "Where did you learn to kiss like that?"

M.E.: "Siphoning gas."

\* \* \*

A preacher at the close of his sermon discovered one of his deacons asleep. He said, "We will now have a few minutes of prayer. Deacon Brown, you lead!"

"Lead?" cried Deacon Brown, suddenly awaking. "I just dealt!"

\* \* \*

Professor: "A fool can ask more questions than a wise man can answer."

Student: "No wonder so many students fail your exams."

\* \* \*

They laughed when I stood up to sing.

How did I know I was under the table.

A scientist discovered a serum that would bring inanimate objects to life. He surreptitiously tried it out on the statue of a great general in Central Park. Sure enough, the statue gave a quiver and a moment later the general, creaking a bit in the joints, climbed down from the pedestal. The scientist was overjoyed.

"I have given you life," he exulted. "Now tell me, General, what is the first thing that you are going to do with it?"

"That's easy," rasped the General, ripping a gun from his holster. "I'm going to shoot about two million pigs!"

\* \* \*

Angry father: "What do you mean by bringing my daughter home at this hour of the morning?"

Engineer: "Have to be in class by eight."

\* \* \*

A women approached the pearly gates and spoke to St. Peter. "Do you know if my husband is here? His name is Smith." "Madam," St. Peter admonished, "we have many Smiths here; you must be more specific. Does he have any outstanding characteristics?" "Well, he always said that if I was ever unfaithful to his name after he died that he would turn over in his grave." "Oh, of course," said St. Peter, "you must mean Whirling Willie Smith."

\* \* \*

The bandage-covered patient who lay in the hospital bed spoke dazedly to his visiting pal:

"Wh-hat happened?"

"You absorbed too many last night, and then made a bet that you could fly out the window and around the block."

"Why," screamed the beat-up C.E., "didn't you stop me?"

"Stop you, hell, I had \$25 on you."

\* \* \*

Ch.E.: "I just bought a skunk."

M.E.: "Where you gonna keep 'im?"

Ch.E.: "Under the bed."

M.E.: "What about the awful smell?"

Ch.E.: "He'll just hafta get used to it like I did."

\* \* \*

M.E.: "How'd you puncture your tire?"

E.E.: "Ran over a bottle of milk."

M.E.: "Didn't see it, huh?"

E.E.: "Naw, the kid had it under his coat."

\* \* \*

"I beg your pardon, but aren't you an engineering student?"

"No, it's just that I couldn't find my suspenders this morning, my razor blades were gone, and a bus ran over my hat."



It is customary to give gifts at Yuletide to the young, who have scant sympathy for your financial plight. A lovable big brother you had better be.

#### THIS WILL DO IT ►

**BROWNIE STARMITE Outfit**—camera (weighing only 8 ounces including built-in flash), film, flashbulbs, batteries, instructions. First package to be opened on Christmas morning for instant fun. Useful on parties and school projects. Educational. Trot down to the nearest camera counter, take care of the matter, and get it off your mind. Doesn't cost much. Leaves you pecuniary margin in selecting a gift for the Fair One, should you be so lucky.



## Kodak beyond the snapshot...

(random notes)

**How to make a double bond**—The man on the left joined our Synthetic Chemicals Division softball team season before last as an outfielder. The one in the middle plays very little softball.

He plays center on the Synthetic Chemicals Division basketball team. The man on the right is well-acquainted with both of the other boys, since he manages *both* the softball team *and* the basketball team. In addition, he had been asked to make 1,4-diphenyl-1,3-butadiene.



The outfielder and the basketball center mentioned that they had developed a new synthesis for olefins *via* a phosphonate intermediate. Well, not exactly new but much faster, easier to work, and better yielding than the prior art had afforded.

"Give," said the manager

"Run the Michaelis-Arbusov reaction and make some diethyl benzylphosphonate," said the outfielder. "That's  $(C_2H_5O)_2P(O)CH_2C_6H_5$ . The benzyl group on it will hook on exothermically to almost any aldehyde. The carbonyl oxygen

from the aldehyde and a proton from the benzyl come off, and a double bond is formed. You have to run the reaction in a strongly basic medium. The new wrinkle is to achieve the alkalinity you need by previously prepared sodium methoxide, with dimethylformamide as your solvent."

"What happens," added the kibitzer, "is the phosphonate reacts with the  $NaOCH_3$  in an equilibrium reaction to form

phosphonate carbanion, which then performs a nucleophilic attack on the aldehyde carbon. For what you want to do, your aldehyde would be  $C_6H_5CH=CHCHO$ . So you get a situation like this where the redistribution of electrons leads to formation of the new double bond and leaves sodium diethyl phosphate."

This colloquy has resulted not only in the availability of 1,4-Diphenyl-1,3-butadiene as EASTMAN 8543 but also of the exceedingly helpful Diethyl Benzylphosphonate as EASTMAN 8559 and of a reprint of a short paper on the method for anybody interested. *N,N*-Dimethylformamide is EASTMAN 5870. We forget who won the ball game.

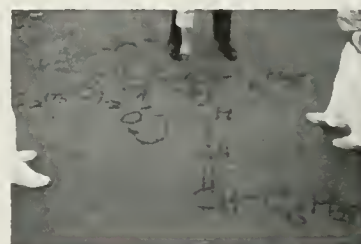

**The Sun play**—Neutrons aren't much good by themselves for exposing photographic materials. Yet a mere few thousand thermal neutrons/mm<sup>2</sup> can give decent photographic images, such as might be useful for neutron radiography (read the wine level inside a lead amphora), neutron diffraction patterns, neutron flux measurements, etc. The topic of photographic detection of neutrons is too quiet for our liking. We wish to have a little noise.

It is done by a triple play: thermal neutrons activate <sup>10</sup>B to emit alphas, which scintillate ZnS(Ag), which gives off visible light that exposes the film. For sharper images at the expense of longer exposure time, neutron fans use an activation technique involving an appreciable half-life. There are gadolinium,

which works by an n, $\gamma$  reaction at an optimum thickness of .074", and dysprosium, which works by  $\beta$  decay at an optimum thickness of .023". Such a neutron converter sheet is exposed without the film and then quickly pulled out of the neutron flux and put in contact with the film. Questions like "What film?" are answered by Eastman Kodak Company, X-ray Division, Rochester 4, N.Y.

A prominent role in all this has been played by a gentleman named Kuan-Han Sun, who once worked for us before his interest turned from non-silicate optical glasses to nucleonics. Married one of our x-ray researchers and took her off with him. Name was Laura McGillivray. Lovely gal.

**EASTMAN KODAK COMPANY**  
Rochester 4, N.Y.

All sorts of products, all varieties of scientific careers at Kodak for B.S., M.S., or Ph. D.

AN INTERVIEW  
WITH G.E.'s  
DR. GUY SUITS,  
VICE  
PRESIDENT  
AND DIRECTOR  
OF RESEARCH



Dr. Suits has managerial responsibility for the General Electric Research Laboratory and as a member of the Company's Executive Office he is directly concerned with G.E.'s over-all research programs and policies. He joined G.E. in 1930 as a physicist, and holds 76 patents, is Chairman of the Directors of Industrial Research, member of the National Academy of Science, Director of American Institute of Physics, previous Chairman of Naval Research Advisory Committee and Fellow of the AIEE, AAAS, and IRE, and has been Vice President and Director of Research since 1945.

For complete information about these General Electric training programs, and a copy of Dr. Suits paper "The New Engineer And His Scientific Resources," write to: Personalized Career Planning, General Electric Company, Section 699-05, Schenectady 5, New York.

# How Scientists and Engineers Work Together in Industry

**Q. Dr. Suits, I've heard a good deal about the scope of your programs. Is your research mostly in physics and electronics?**

A. This is a common misconception. The work of the many laboratories of General Electric "covers the waterfront" in science and in advanced engineering technology. Some laboratories specialize in electronics research, others in atomic power, space technology, polymer chemistry, jet engine technology, and so forth. Actually, the largest single field represented by the more than 1000 Ph.D. researchers in General Electric is chemistry.

**Q. Is this research performed principally by people with Ph.D. degrees in science?**

A. General Electric research covers a broad spectrum of basic and applied work. At the Research Laboratory we focus largely on basic scientific investigations, much as in a university, and most of the researchers are Ph.D.'s. In other Company laboratories, where the focus is on applied science and advanced engineering, engineers and scientists with B.S. and M.S. degrees predominate. Formal college training is an important preparation for research, but research aptitudes, and especially creative abilities, are also very important qualities.

**Q. What are the opportunities for engineers in industrial scientific research and how do scientists and engineers work together in General Electric?**

A. Classically, engineers have been concerned with the problem "how," and scientists with the question "why." This is still true, in general, although in advanced development and in technological work scientists and engineers work hand-in-hand. Very close cooperation takes place, especially in the increasingly important fields of new materials, processes, and systems. Certainly in General Electric, a person's interest in particular kinds of problems and his ability to solve them are more important than the college degree that he holds.

**Q. What does it mean to an engineer to have the support of a large scientific research effort?**

A. It means that the engineer has ready access to the constant stream of new concepts, new materials, and new processes that originate in research, and which may aid his effort to solve practical problems. Contact with research thus provides a "window" on new scientific developments—world-wide.

**Q. How does General Electric go about hiring engineers and scientists?**

A. During each academic year, highly qualified technical people from General Electric make recruiting visits to most college campuses. These men represent more than 100 General Electric departments and can discuss the breadth of G.E.'s engineering and science opportunities with the students. They try to match the interests of students and the Company, and then arrange interview visits. The result of this system is a breadth of opportunity within one company which is remarkable.

Experienced technical people are always welcome, and they are usually put in contact with a specific Company group. Where no apparent match of interests exists, referrals are made throughout General Electric. In all cases, one finds technical men talking to technical men in a really professional atmosphere.

**Q. Are there training programs in research for which engineering students might be qualified?**

A. There certainly are. Our 2-year Research Training Program at the General Electric Research Laboratory gives young scientists a chance to work with experienced industrial research scientists before carrying out research and development on their own.

In addition, there are seven Company-wide training programs. Those that attract the largest number of technical graduates are the Engineering and Science, Technical Marketing, and Manufacturing Training Programs. Each includes on-the-job experience supplemented by a formal study curriculum.

Of course, not all graduates are hired for training programs. In many cases, individuals are placed directly into permanent positions for which they are suited by ability and interest.

GENERAL  ELECTRIC



C  
LZe35t  
cop 2

S

711  
Coll.

# TECHNOGRAPH

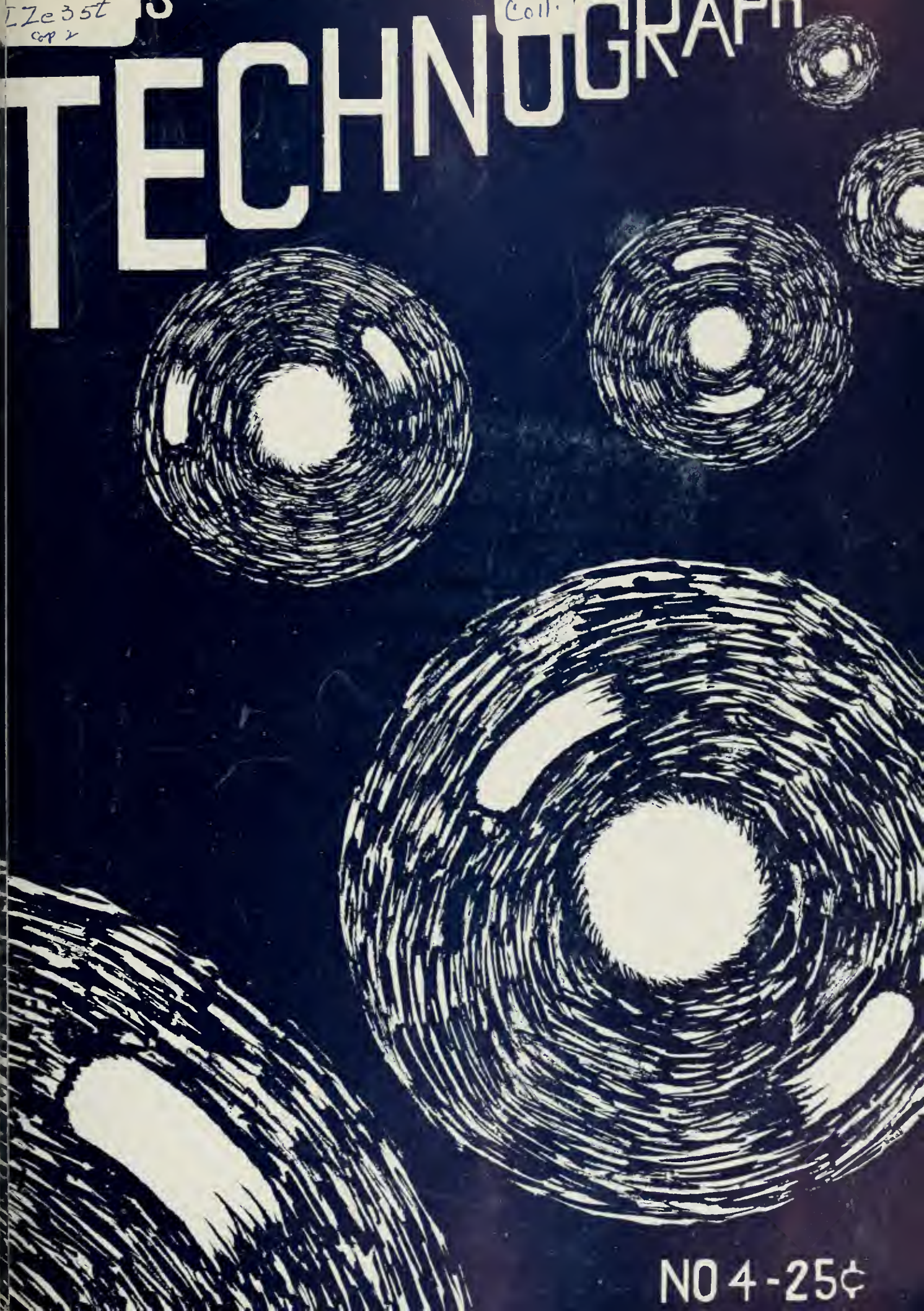

NO 4-25¢



**What's down under the sea?** Hostile submarines? New food sources? Biological wonders like the archaic coelacanth fish? In many ways, we know more about the surface of the moon than we do about the sea around us. The sea guards its secrets in darkness, with pressures that crush steel like an eggshell. Radio waves that put us in touch with the stars can penetrate less than 100 feet of its depth. Westinghouse scientists are helping to unravel the sea's

mysteries by perfecting new precision instruments for measuring salinity, acoustics, currents, pressures, sea floor contours. Westinghouse was the first to develop centralized engine room control for oceanographic ships, a development that will help make hydrographic and oceanographic surveying faster and more accurate than ever before. New undersea propulsion methods under investigation at Westinghouse involve fuel cells, thermo-

electric generators, thermionic converters, cryogenic propellants. Strange words, strange world. For more information concerning a challenging career at Westinghouse, an equal opportunity employer, see our representative when he visits your campus, or write L. H. Noggle, Westinghouse Educational Center, Pittsburgh 21, Pennsylvania. You can be sure . . . if it's

**Westinghouse**







## Life sciences study effects of long range space travel

The life sciences group at The Garrett Corporation is concerned with the reaction of living organisms to their environment, and the development of environmental systems to support such organisms.

Intensive investigation is now being conducted at Garrett in all major areas of the life sciences—microbiology, neurophysiology, psychology, biochemistry, biophysics and related areas—to study the relationships of man to his environment in extended space travel. These studies vary in scope from determining the effects of near vacuum conditions on labora-

tory subjects over long periods of time, to definitively evaluating the effects of re-entry acceleration on human beings.

Garrett also designs, develops and manufactures environmental control systems for this country's major manned spacelight programs, including Project Mercury, Gemini and Apollo.

For information about other interesting projects and the many career opportunities with The Garrett Corporation, write to Mr. G. D. Bradley in Los Angeles. Garrett is an equal opportunity employer.



THE GARRETT CORPORATION • AiResearch Manufacturing Divisions • Los Angeles 9, California • Phoenix, Arizona • other divisions and subsidiaries: Airsupply-Aero Engineering • AiResearch Aviation Service • Garrett Supply • Air Cruisers • AiResearch Industrial • Garrett Manufacturing Limited • Garrett International S. A. • Garrett (Japan) Limited

# WHY GAMBLE?



Most of us "gamble" a little every day. Have you ever driven past a service station with the gas gauge on empty, betting you'll reach the next one? But when reliability is important we're not likely to gamble. In the electric utility business the need for reliability is essential. It's the power engineer's job to take the "gamble" out of providing uninterrupted electric service. At Wisconsin Electric Power Company a high degree of reliability has been maintained, due largely to the technical ability, judgment and experience of its power engineers. Now a new means of analysis is being studied — a reliability theory, using the mathematics of probability and worked out on digital computers. These studies will add a new dimension to the power engineer's ability to select components to provide ever more reliable generation, transmission and distribution of electricity in the future.

Why gamble your future? Take a hard look at the many engineering opportunities in the Wisconsin Electric Power Company System. Here you will find well-rounded training programs and opportunities for technical growth with administrative possibilities. Employment benefits are excellent with salary growth and promotion based on personal merit. Write us for information now.

## WISCONSIN ELECTRIC POWER COMPANY SYSTEM

Wisconsin Electric Power Co.  
MILWAUKEE, WIS.

Wisconsin Michigan Power Co.  
APPLETON, WIS.

Wisconsin Natural Gas Co.  
RACINE, WIS.

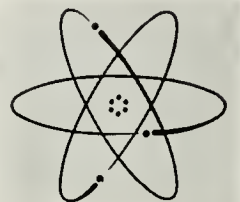



**Editor-in-Chief**  
Wayne W. Crouch

**Associate Editor**  
Gary M. Daymon

**Office Manager**  
Thelma McKenzie

**Production Manager**  
Scott Weaver

**Circulation Manager**  
Gary Bilow

**Editorial Staff**  
Art Becker  
Larry Druffel  
Ted Morange  
Bill Small  
James Walters

**Business Staff**  
Phillip Johnson  
Wayne Worthington

**Production Staff**  
Mike Glowacz

**Circulation Staff**  
Bob Bittner  
Paul Gihring  
Dick Kolb  
George Muellner

**Photography**  
Jay Dickinson  
Joe Figueira

**Advisors**  
R. W. Bohl  
P. Bryant  
W. M. Hudson  
E. C. McClintock

# THE ILLINOIS TECHNOGRAPH

Volume 78; Number 4

January, 1963

## Table of Contents

### ARTICLES

Zetetics—The Science of Research.....	Larry Druffel	10
Engineers Who Aren't.....	Larry Balden	15
Clean Hi-Fi Sound from a Sewer Pipe.....	Jim Walters	18
Machine That Diagnoses Its Own Failures.....		23
Ion Propulsion.....	Art Becker	26
Glass Stranger Than Steel.....	Vic Bell	30
Cryobiology.....	Wayne Crouch	34
Lack of Culture.....	Benny Babb	38

.....

### FEATURES

Dean's Page.....	Dean D. R. Opperman	6
TECH Says.....	Gary Daymon	7
News and Views at the U. of I.....	Gary Daymon	22
Technocutie.....	Photos by Dickinson and Figueira	31
Engineering Calendar.....		46
Technoquips .....		47

### MEMBERS OF ENGINEERING COLLEGE MAGAZINES ASSOCIATED

Chairman: J. Gale Chumley  
Louisiana Polytechnic Institute  
Ruston, Louisiana

Arkansas Engineer, Cincinnati Coopera-  
tive Engineer, City College Vector, Colorado  
Engineer, Cornell Engineer, Denver Engi-  
neer, Drexel Technical Journal, Georgia  
Tech Engineer, Illinois Technograph, Iowa  
Engineer, Iowa Transit, Kansas Engineer,  
Kansas State Engineer, Kentucky Engineer,  
Louisiana State University Engineer, Louisi-  
ana Tech Engineer, Manhattan Engineer,  
Marquette Engineer, Michigan Technic, Min-  
nesota Technologist, Missouri Shamrock, Ne-  
braska Blueprint, New York University  
Quadrangle, North Dakota Engineer, North-  
western Engineer, Notre Dame Technical  
Review, Ohio State Engineer, Oklahoma  
State Engineer, Pittsburgh Skyscraper, Pur-  
due Engineer, RPI Engineer, Rochester In-  
dicator, SC Engineer, Rose Technic, South-  
ern Engineer, Spartan Engineer, Texas  
A & M Engineer, Washington Engineer,  
WSC Technometer, Wayne Engineer, and  
Wisconsin Engineer.

### The Cover: by Bill Small

Editor: "What's that?"  
Artist: "Ion Propulsion."  
Editor: "Doesn't look like Ion Propulsion to me."  
Artist: "You've seen, maybe, an ion lately?"

Copyright, 1962, by Illini Publishing Co. Published eight times during the year (Oc-  
tober, November, December, January, February, March, April and May) by the Illini  
Publishing Company. Entered as second class matter, October 30, 1920, at the post  
office at Urbana, Illinois, under the Act of March 3, 1879. Office 215 Engineering  
Hall, Urbana, Illinois. Subscriptions \$1.50 per year. Single copy 25 cents. All rights  
reserved by *The Illinois Technograph*. Publisher's Representative - Littell-Murray-  
Barnhill, Inc., 737 North Michigan Avenue, Chicago 11, Ill., 369 Lexington Ave.,  
New York 17, New York.

This coined word applies to the emission of electrons which occurs at the time of metal abrasion or fracture. Refined measurement techniques in regard to this factor may lead to the detection of microscopic cracking long before failure ...allowing for part replacement before the onset of fracture in service. Triboelectroemanscence is only one of the many phenomena involving metal behavior now under study at Douglas. Because structural reliability is a critical consideration in the design of transonic, supersonic and hypersonic aerospace vehicles, Douglas laboratories are engaged in a

## TRIBOELECTROEMANESCENCE

...A STIMULATING AREA FOR CREATIVE ENGINEERS

comprehensive research program relating to metal endurance. This includes corrosion causes and effects, environmental studies, and the effects of steady state loads and intermittent strains under cryogenic through pyrogenic temperatures in causing metal cracking.

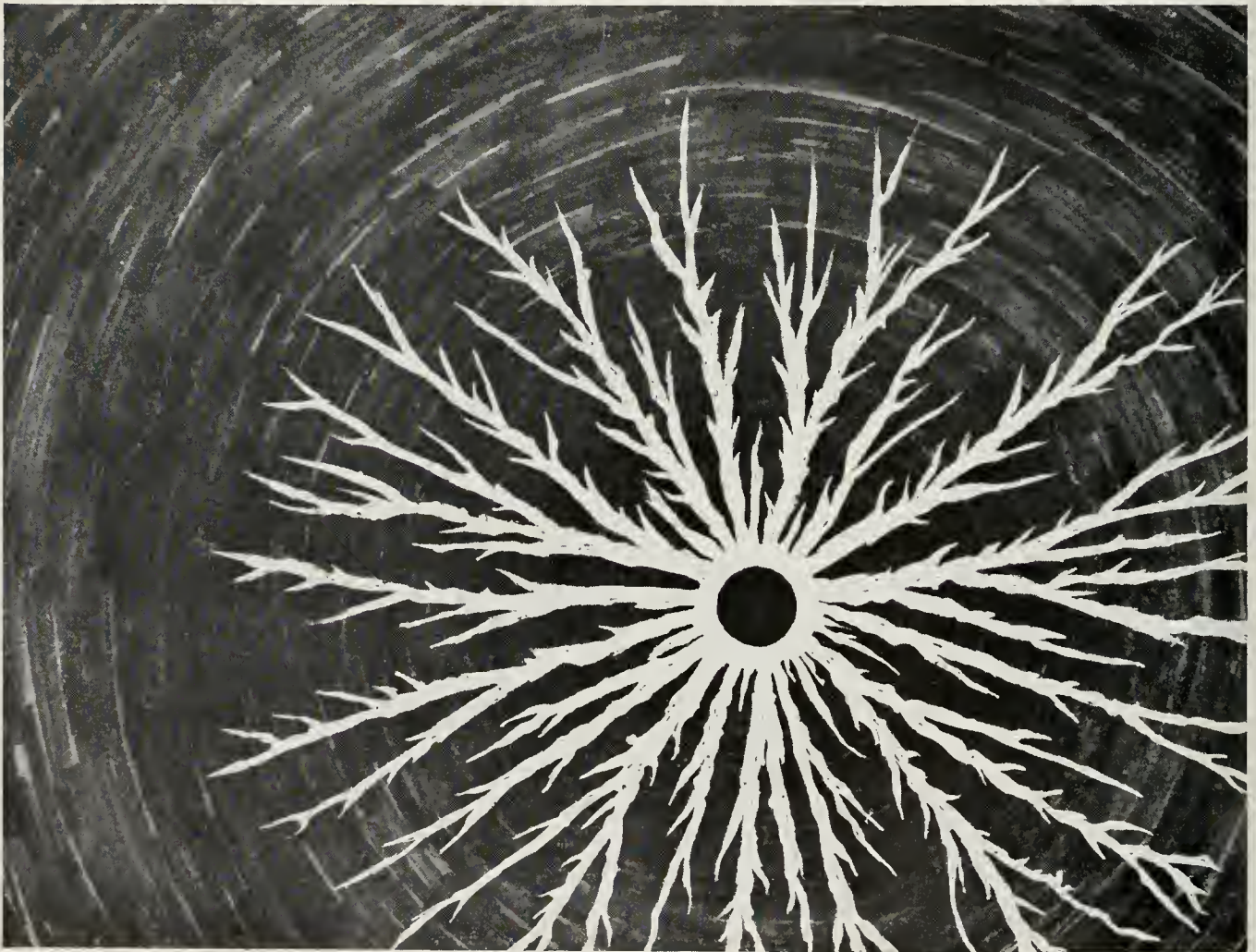

The above is only one of hundreds of interesting assignment areas at Douglas. If you are seeking a stimulating career with an organization in the thick of the most vital programs of today and tomorrow, we invite you to contact us. Please write to Mr. S. A. Amestoy, Douglas Aircraft Company, 3000 Ocean Park **DOUGLAS** Boulevard, Santa Monica, California, Box 600-M. Douglas Aircraft is an equal opportunity employer.

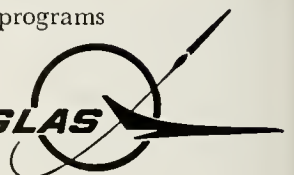



Electronic Engineers  
 Mathematicians  
 Physicists  
 BS — MS — PhD

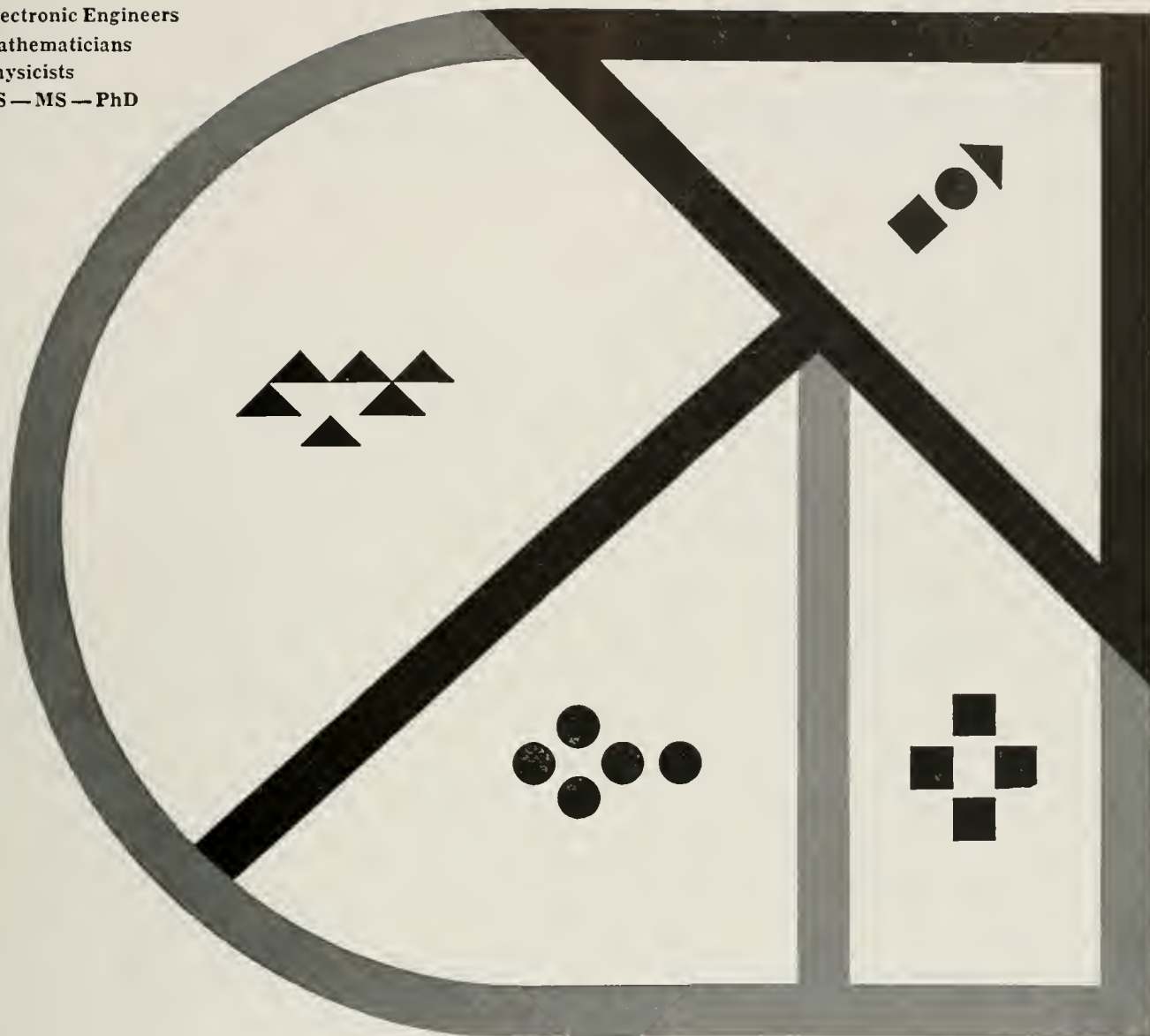

There's a bracing climate of spirited inquiry, debate and experimentation at Sylvania Electronic Systems — an environment that prompts bold, new ideas and nurtures them to maturity.

Small congenial groups that encourage individual expression staff the 17 interrelated laboratories located in suburban Boston, Buffalo and San Francisco — and the reciprocal flow of information among these laboratories provides the young professional with a remarkable wealth of knowledge in the current state of the art.

A major division of Sylvania Electric Products Inc., Sylvania Electronic Systems provides overall systems engineering and management on major government projects for the parent company, General Telephone & Electronics.

Our programs encompass almost all of today's advanced electronic disciplines — space/earth communications, elec-

## AN OPTIMUM ENVIRONMENT FOR INQUISITIVE MINDS

tronic reconnaissance, detection, countermeasures, information handling, complex systems for military command and control.

For example, the Division's newest task, as prime contractor to the Air Force, is to provide a blast-resistant ground electronics system for command and control of unmanned Minuteman ICBM sites.

Backed by the vast technical and financial resources of GT&E, Sylvania Electronic Systems provides the young engineer and scientist with broad-scope stability essential for a rewarding career. SES's long-range growth pattern gives substance to our concept of 3 parallel paths to advancement — in technical specialization, technical management or program/project management, with *equal* rewards in all.

For more complete details, see your College Placement Director, or write to Mr. Robert T. Morton.



40 Sylvan Road — Waltham 54, Massachusetts

An Equal Opportunity Employer - U.S. Citizenship Required

# SCHOLARSHIPS IN ENGINEERING

By Dean D. R. Opperman

The scholarship program in the College of Engineering is big business. Over one-quarter of the undergraduate engineering students on this campus hold some type of scholarship award with a total value of over \$200,000.00.

Scholarships held by engineers come from a variety of sources. The largest single source is the County Scholarship Program, which awards tuition scholarships on the basis of a county-wide competitive examination. Though they are not awarded by the College of Engineering Scholarship Committee, we consider them a part of the program of scholarship aid available to engineers.

The second largest number of scholarships held by engineers are the Illinois State Scholarships. They are awarded on the basis of state-wide examinations and exempt the winners from tuition plus fees. The winner may attend any college or university in the State of Illinois and receive up to a maximum of \$600.00 for tuition and fees. Since the program involves many schools, these scholarships, similar to County Scholarships, are not awarded by the engineering committee.

The College of Engineering Scholarship Committee concerns itself with making recommendations for scholarships which are termed "cash scholarships." This program is the third largest program in the college both in terms of numbers of students and in dollars of value to undergraduate engineers. These scholarships, supported by 40 industrial corporations and foundations, may be awarded only to students in the College of Engineering.

Our scholarship program is a part of the total scholarship program at the University of Illinois. Therefore, in order to assure maximum consistency in the scholarship program at the university, all scholarships originated by the engineering committee must be forwarded to the all-university Committee on Special Undergraduate Scholarships for final approval. Since the College of Engineering committee works closely with the all-university committee and agrees with its policies for scholarship awards, most of the recommendations from our college are accepted by the all-university committee.

What are the policies established by the all-university committee? Two major criteria must be met to receive scholarship awards. First, and most obvious, is

that a student must have a high grade point average. An average of 4.5, or above, will give the scholarship applicant top priority. The second category will include students whose averages are between 4.0 and 4.5. These two categories include most of the scholarship awards but a third category, 3.75 to 4.0, sometimes includes a winner. Students with averages below 3.75 have very little chance of receiving any scholarship award at the University of Illinois under our current programs and procedures.

The second criterion that students must meet is financial need. A statement appears in the General Rules Concerning University Organization and Procedure as follows: "The recipient of a scholarship or fellowship shall be chosen by appropriate university agencies, in accordance with established criteria based upon scholastic attainment and financial needs." Since these rules are approved by the Board of Trustees, it is necessary that all scholarship applicants have a financial need to be given serious consideration for a scholarship award. Incidentally, getting married between the junior and senior year in college does not alter the financial need criterion.

Financial need is a factor difficult to evaluate. In general, ownership of an automobile greatly decreases the evaluation of financial need whether or not the automobile is on campus and operated by the student. The engineering and the all-university committees both feel that if a student had a dire financial need it would be possible for him to sell his automobile and still be a student at the University of Illinois.

Because of the complexity of evaluating financial need, the University of Illinois is considering joining with 389 other institutions that subscribe to the College Scholarship Service where financial need is evaluated by an outside agency. Only four Big Ten universities are not members of the College Scholarship Service.

Though most of the engineers holding scholarships are found in the three groups mentioned previously in this article, a sizeable number of our students win additional cash scholarships in competition on a university-wide basis. The Engineering Scholarship Committee receives approximately twice as many applications as there are available scholar-

ships. After all available engineering scholarships are awarded in late spring, the applications are forwarded to the all-university committee. This committee is charged not only with the responsibility for approving awards recommended by the colleges, but also for awarding scholarships that the donor has not restricted to any particular college of the university.

The following figures will demonstrate just how well engineers make out in scholarship competition at the university. Approximately 5,487 students at the university hold tuition, state, or cash scholarships or an outside award of some type, amounting to a total value of \$1,217,871.00. Of these totals 1,070 students are engineers who received \$210,928.00 worth of scholarship aid. Though our enrollment constitutes only 18% of the student body, our students hold 20% of all scholarships having 17% of the cash value of the scholarships. Engineers can well be proud of their scholastic attainment which makes this record possible.

Unfortunately, in the above data freshmen represent a minority group. Most cash scholarships at the university specify that they be awarded to sophomores and above, since freshmen are a big question mark until after their first semester is completed. There are only 17 cash scholarships available to incoming freshmen each fall to cover the needs of the 900 freshmen that enter. Though many of the freshmen will hold county scholarships and Illinois State Scholarships there is still a great need for additional aid for freshmen. Scholarship applications from top freshmen are always encouraged though, so that the limited number of scholarships will be awarded to the most deserving students. However, a high school student planning to enter the University of Illinois who needs scholarship aid should be sure and take the county and state scholarship examinations rather than depend upon winning a cash award at the university.

There is no deadline for applications, but the student who submits an application after May 1 is definitely at a disadvantage since most of the scholarship awards are made prior to May 1. If you receive a letter about March 15 this year, don't delay in returning it to us if you feel you could qualify for a scholarship award. ♦♦♦



## READ BETWEEN THE ARTICLES

Since the days of Hadacol the American public — which incidentally includes engineering students — has been consciously and sometimes critically aware of the impact of advertising on their lives. The irritating effects of 'Mellcw and Mild Washall' and a million more television and magazine commercials has made commercial advertising just short of the public's number one pet peeve . . . to the point we often wish just a third of the clever advertising talent would be used to improve the magazine articles and television programs. Even so, the graduating engineer, who has assiduously studied for four years under a protective umbrella created by the seemingly infinite demand for engineers, can benefit greatly in the proper job selection from a unique type of "advertising"—as distinguished from advertising.

The proud engineering graduate who agily enters room 109 Civil Engineering Hall (the Engineering Placement Office) should not expect to reactively select an industrial employer. For instance, electrical engineers rapidly recognize the names of the larger companies such as General Electric, Sylvania, and Raytheon, but what do the other 450 less familiar companies, several of which the student engineer has never heard of, have to offer? Conversely, what do the larger companies have that the smaller ones lack—except bigness?

You just passed over five answers, or at least leads, as you thumbed to this editorial . . . Yes, ECMA "advertising." Don't overlook Babcock and Wilson's comparison of large and small companies, p. 21.)

ECMA (Engineering College Magazines Associated) "advertising" not only provides over \$1,300 in "advertising" revenues to each TECHNOGRAPH issue, but it is one of the chief means utilized by industrial companies to inform engineering students of the types of products being developed and manufactured and the engineering manpower required. Their training and advancement programs receive equal attention, and timely tips on interviewing and management opportunities are discussed. In fact, ECMA "advertising" represents the most personalized student-company contact currently used by industry.

Check over the "ads" appearing in this and other issues of TECH. As odd as it may seem, Ford has not tried to sell you a new car, nor has Collins advertised a radio. All "ads" are designed to acquaint an invaluable future company asset — you, the graduating engineer — with the company. The companies' future well being hinges upon advanced technology, and you represent that source.

Likewise, **your** future success depends upon your selection of the right company. How else can an engineering graduate intelligently select the right employment without first obtaining a firm knowledge of the company? Take a few minutes to carefully study the "ads"; utilize the additional free information available by personally writing the various companies; learn the diverse engineering positions available; discover which company meets your specifications; and remember, you are not only selecting a company, but the company is also selecting you. Only by exhibiting a genuine interest in and well informed knowledge of the company, as well as meeting the technical requirements, can you expect to receive a job offer.

Start now! Read between the articles in TECH, and see what we mean by "advertising." The time to become familiar with the wide variety of industrial companies — your future employers — is now, not the week you graduate.

by Gary M. Daymon



## National Powers the Polyethylene Pellet

... and opens up a new world of plastic applications

Magical things happen when polyethylene resin—usually shipped in barley-sized pellets—is made the consistency of flour. The powder can perform like a liquid. It can be sprayed, cast, used for coatings . . . stirred as an additive in waxes and lubricants . . . molded into products so large as to be prohibitively expensive if made by any other plastics process.

Since National's U. S. Industrial Chemicals Co. division introduced MICROTHENE® powdered polyethylene resins two years ago, end-uses have sky-rocketed. One example—molded auto carpeting backed with polyethylene coating. Another—new popularity for rotational molding of hollow plastic items.

MICROTHENE typifies the customer-oriented product development made possible by National's expansion in plastics. Among the latest developments are: (1) forma-

tion of 50 per-cent-owned Alamo Polymer Corporation to manufacture polypropylene resins and films in Texas, (2) creation of U. S. I. Film Products to market polyolefin films and packaging, and (3) near completion of a linear polyethylene plant—also 50 per-cent-owned.

*As the only company now on record with plans to produce all major types of polyolefin resins and film, National is in a unique position to meet customer needs and to make the most of growth situations in any area of the polyolefin plastics and film market.*

**A Career at National . . .** National is moving ahead. Chemists, engineers and metallurgists seeking an unlimited future in plastics, chemicals or metals are invited to contact our Professional Employment Mgr., 99 Park Avenue, New York 16, N. Y.

## NATIONAL DISTILLERS and CHEMICAL CORPORATION

Divisions: NATIONAL DISTILLERS PRODUCTS CO. • U. S. INDUSTRIAL CHEMICALS CO. • BRIDGEPORT BRASS CO. • FEDERAL CHEMICAL CO.

*Growing in these major areas of service:*  
Liquors • Chemicals • Plastics • Fertilizers • Metals





## BAYMAL®—one of our many new products that could launch a thousand careers

New careers are important by-products of Du Pont research. Developing BAYMAL\* is a case in point.

BAYMAL is a white, free-flowing powder. It's intentionally synthesized into submicron-sized fibrillar particles about 5 millimicrons in diameter and about 200 millimicrons in length. These small particles display a number of properties completely different from other types of alumina now available.

Dispersibility to form stable sols with unique thixotropy, viscosity and film forming characteristics is one of its notable properties. Our photos illustrate another. Shake a BAYMAL-and-water solution and it will pour. Let it sit awhile and it will gel—won't pour unless you agitate it again.

We see dozens of potential uses for BAYMAL. But it's up to our development men to bring this new product to commercial maturity, and here is where careers are born.

You see, from the day we examine a sample of the chemical to the day a full-scale plant starts turning out the finished product, years may elapse—years of patient work by chemical engineers developing processes and assembling basic data for process design, by mechanical engineers who must create new equipment to make the product, by electrical engineers whose job it is to develop control systems to meet the needs of the process.

And BAYMAL is just one of literally hundreds of new products under development at Du Pont. Each one gives promise of new and rewarding careers for technical men—perhaps like yourself—preparing to enter industry.

If you'd like to receive information about employment opportunities at Du Pont, and to know more about BAYMAL and other new Du Pont products featured in our "Opportunities" series, use our coupon. Mail it today.

\* Du Pont's registered trademark for its colloidal alumina



BETTER THINGS FOR BETTER LIVING... THROUGH CHEMISTRY

An equal opportunity employer

E. I. du Pont de Nemours & Co. (Inc.)  
Nemours Building, Room 2531-1, Wilmington 98, Delaware

Please send me the literature indicated below.

- Du Pont and the College Graduate
- Mechanical Engineers at Du Pont
- Engineers at Du Pont
- Chemical Engineers at Du Pont
- "Opportunities" series technical information

Name \_\_\_\_\_

Class \_\_\_\_\_ Major \_\_\_\_\_ Degree expected \_\_\_\_\_

College \_\_\_\_\_

My address \_\_\_\_\_

City \_\_\_\_\_ Zone \_\_\_\_\_ State \_\_\_\_\_

# ZETETICS – The Science of Research

by Larry Druffel BSEE '63

## The Man:

Joseph T. Tykociner was born Oct. 5, 1877, in Vioclavek, Poland. After graduating from the Higher Technical Institute at Coethen in 1901, he studied in Berlin and Goettingen, Germany. Throughout his academic career, he realized that the significant information was not in the already published text books, but rather in the few existing technical journals. As a student, he devoured whatever literature was available, always awarding top priority to communication and basic research. At the age of 25, he was interviewed by the chief engineer at Marconi Wireless Telegraph Company of Chelmsford, England. To the surprise of that interviewer, Joseph Tykociner was well versed in the communication technology of the time. Since the schools did not offer courses in wireless communication, Joseph's knowledge was rare for a new graduate.

In 1904, he became a research engineer at the Telefunken Wireless Telegraph Company of Berlin. The next year found him organizing a radio department in Russia for the Russian Siemens Company in St. Petersburg, where he stayed until 1918. While in Russia, he developed and installed radio equipment for the Russian Armed Forces, making the Russian Navy the first completely radio equipped navy in the world.

He returned to Warsaw, Poland, in 1918 to do research work at the Radiological Laboratory of Warsaw. In 1920, Joseph came to the United States to work for Westinghouse Electric. He became a research professor of Electrical Engineering at the University of Illinois in 1921, and professor in the graduate school in 1929.

While at the University of Illinois, he developed sound on film which eventually paved the way for the first "talkies." At the time he developed his "Actophone," a leader of the film in-



Prof. Joseph T. Tykociner

dustry, George Eastman, advised a faculty member of the University that sound film would never be accepted by the public. The university chose not to further the development of the "Actophone," which utilized the same methods as modern sound movies.

This incident presents a good view of the character of Joseph Tykociner. Undoubtedly, he is a pioneer in the field of electronics. On many occasions, when arriving at the crossroads of electronic breakthrough, other pioneers have followed the trails previously blazed by Joseph T. Tykociner. However brilliant he is, Joseph is a quiet, culturally sensitive man. When discouraged, he was content to let his great invention become the property of the public. Content in the realization of his own success, he sought no acclaim or monetary compensation.

Later, while experimenting with antenna models in a pasture, he noticed that distant cows were bothered by his device. He was unable to continue be-

cause of this ill effect. The investigation which was discouraged from completion became the property of the public and years later led to various applications of short waves, such as radar and direction finding. Here again, his scientific prescience is apparent: so far ahead of his time that others had to catch up before they could appreciate and use his ideas; so unasserting as to be swayed from pecuniary rewards.

Some of his pioneering work includes antenna models, high frequency measurements, dielectrics, piezoelectricity, photoelectric tubes, and microwaves.

At the age of 84, long after other men have forsaken their careers, Joseph Tykociner is still a pioneer; still trying to give a deaf world the benefit of his mind.

He is founding a new science of Zetetics (from the Greek "zeteto" to investigate), which is the science of research. To many, it comes as a shocking surprise that such a science does not exist. Considering the many years of research witnessed by recent generations and the breakneck pace with which it is being conducted, a science of research is logically long overdue. Psychologically however, the public does not seem ready for it. Once again, Joseph Tykociner may be too far ahead of the world. After a lifetime of research, he has become aware and sensitive to the sometimes haphazard research methods. He has realized the need for a science of research; but has the rest of the world? He has responded to that need, but is the world prepared to receive it?

In 1959, Joseph Tykociner consolidated much of his work in his privately published book, *Research as a Science—Zetetics*, which is distributed by the University of Illinois Experiment Station. This fall, he returned to the University to teach the first course in Zetetics, which he will repeat again in the spring.



**"Zetetics is the totality of recorded, systematized knowledge**

*related to such*

- methods of research
- mental processes
- psychological factors and
- environmental conditions

as . . .

- lead to new problems
  - stimulate creative imagination
  - enhance selective thinking and
  - generate original, fruitful ideas."
- Joseph T. Tykociner

**His Work:**

To avoid Semantic misunderstanding, Professor Tykociner has specified the definition of three key words. "Knowledge," he says, "is the totality of information preserved by culture. Science is the sum total of recorded systematized knowledge thus far accumulated by the human race. Research is the striving for new knowledge."

In the study of a science, the first consideration must be to fundamentals and foundation. The foundation of zetetics is knowledge, which is presented to us in the various sciences. His first step was to categorize man's knowledge. After 36 years work, 1400 arts and sciences have been catalogued. Although this list does not include every known art and science, the missing number is quite small and is still under attack. Each of the arts and sciences fits into one of twelve areas of knowledge. Professor Tykociner has illustrated the totality of knowledge in a very interesting illustration shown in Figure 1.

Region I, the dark region surrounding the four concentric circles represents that knowledge which is inaccessible to man because of his limitations. However, if evolution continues to favor man by increasing his mental faculties, the dark region can be penetrated. Region II, that of the outermost gray circle, represents knowledge which is accessible but as yet unknown to man. Region III contains all knowledge of which man is aware but has not systematized (i.e., all knowledge that is not incorporated into one of the accepted sciences). Region IV encompasses all science. Region V has been reserved for a complete integration of human knowledge.

Regions IV and V are of the greatest interest in the explanation of zetetics. Region IV is divided into twelve areas of knowledge.

**(1) Ar the arts**

"The arts are the results of creative activity (zetesis) which, intensified by

inspiration, produces objects of aesthetic quality." This is the area of knowledge in which symbolic patterns are formed in various media to represent life. These include: architecture, music, painting, choreography, sculpture and literature.

**(2) Sy Symbolics of Information**

Herein lie the tools used by all scientists. These are the various sciences of systematic communication, with which the scientist not only thinks but also communicates his thoughts to others. Mathematics, linguistics, logic, information theory and conceptology are the key sciences in this area.

**(3) Hy Hylenergetics**

The sciences dealing with matter and energy represent one of the more diverse areas of knowledge. The sciences in this area are man's application of the previous area, the Symbolics of Information. Physics, chemistry, astronomy, geology, and mineralogy are the basic sciences.

**(4) Bi Biological Sciences**

Science moves to consideration of life. There are many sciences concerned with the study of life, but all are unified by the principle of evolution. Botany, zoology, morphology, genetics and physi-

*(Continued on Page 14)*

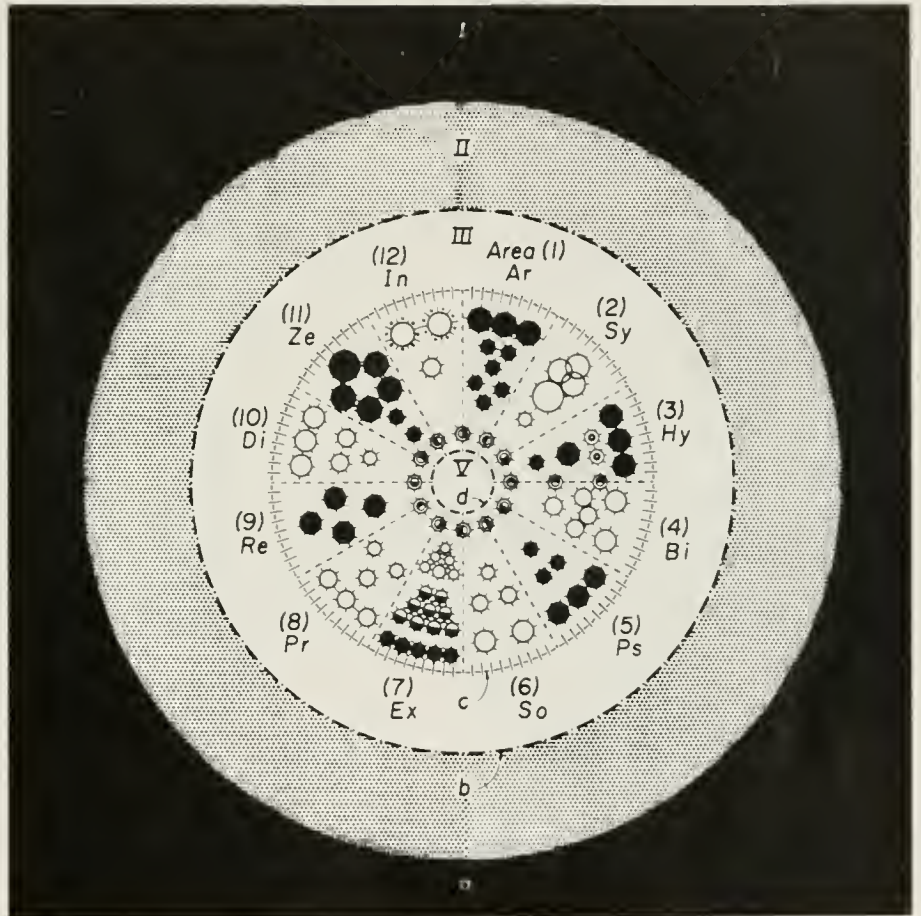

Figure 1. Diagram of knowledge classified into regions and areas.

*Opportunities are better than ever at Bethlehem Steel!*



## What kinds of engineers do you find with Bethlehem?



Here's the answer: Chemical Engineers . . . Civil Engineers . . . Electrical Engineers . . . Industrial Engineers . . . Mechanical Engineers . . . Metallurgical Engineers . . . Mining Engineers . . . Naval Architects and Marine Engineers, and more.

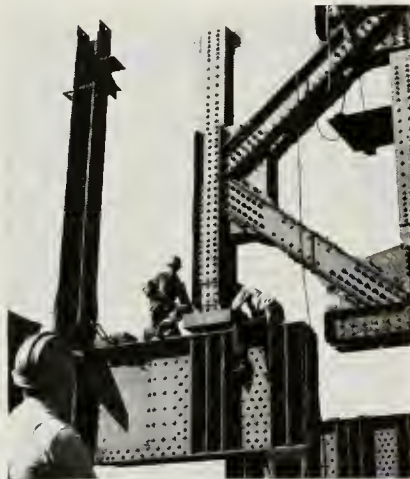

*Every* major engineering degree is represented within the management ranks here at Bethlehem Steel.

It makes sense. The mining and processing of minerals obviously suggest the need for Mining Engineers. Then come the chemical processes of coke-making, smelting, refining. Fuels are consumed, valuable by-products are made. Is it any wonder steelmaking calls for Chemical Engineers?

And how about the machinery, the

mills, the furnaces, the instrumentation that make up a modern steel plant? Mechanical Engineers design them, and frequently supervise installation. Civil Engineers design and put up the buildings to house them, and the feed lines to keep them supplied.

Power? Steel is the biggest industrial consumer of electric power. You cannot conceive of a greater concentration of electrical equipment than in a modern steel mill. And many steel plants *generate* electric power, too. Electrical Engineers are busy fellows in the steel industry.

Steelmaking calls for volume production, complex and scientific, often highly automated. We manufacture numerous finished products, too, from nuts and bolts to nuclear-powered cruisers. The Industrial Engineer finds plenty to do here at Bethlehem.

What's more, the kind of engineering degree does not limit a Looper's assignments. The superintendent of a huge open-hearth department, or a giant rolling mill, might well be an M.E., a Ch.E., a Met.E., an I.E., or C.E.

### Sales Engineers

Because of the nature of our products, a man with a technical background and a "sales personal-

ity" has a great opportunity in sales with Bethlehem Steel.

### Research

Our research policy and our magnificent new research laboratories, in Bethlehem, Pa., offer unexcelled opportunities for research and development engineers and scientists. The exciting results of research promise bright prospects for all Bethlehem operations.

### Shipbuilding

As the world's largest privately owned shipbuilding and ship repair organization, Bethlehem offers careers to Naval Architects and Marine Engineers, as well as to engineers in many other categories.

### The Loop Course

This program was established some forty years ago, to select and train well-qualified college graduates for management careers in the Bethlehem organization. It was so named because of an observational circuit (or "loop") of a steel plant. After a five-weeks' basic training period, which is held once a year at company headquarters in Bethlehem, Pa., loopers receive their first assignments, which call for specialized training that may last for a few weeks or for as long as a year. Next comes on-the-job training, and the looper is on his way.

*An equal opportunity employer*



# BETHLEHEM STEEL







## The sky is not your limit

You're looking at an historic first — a 238,857 mile lunar bull's-eye scored by a team of scientists from Raytheon and the Massachusetts Institute of Technology, using a powerful new Raytheon-developed laser light beam. This success typifies the far-ranging variety of advanced projects challenging young engineers and scientists at Raytheon today.

For EE's, math and physics majors — in all the varied fields of engineering and science — Raytheon offers unlimited opportunity for growth and continuous advancement.

Personal career development is encouraged by a wide variety of educational assistance . . . seminars, special courses to meet individual needs and work-study programs leading to advanced degrees from renowned universities are all available.

You may well qualify for one of the exciting, career-building projects underway at Raytheon. Originality, imagination and high technical competence are your tools — the rewards are prompt and appropriate for success.

For detailed information, arrange an on-campus interview through your placement director or write G. W. Lewis, Manager of College Relations, Raytheon Company, Executive Offices, Lexington 73, Mass. An Equal Opportunity Employer.

**Raytheon offers opportunities for BS, MS and Ph.D. levels in** • Solid State • Microwave Electronics  
• Infrared • Lasers • Communication & Data Processing  
• Radar • Missile Systems • Sonar • Electron Tube Technology



## Zetetics . . .

(Continued from Page 11)

ology are all concerned with the living world. Biophysics and biochemistry provide the link to area three.

### (5) **Ps Psychological Sciences**

Science progresses to encounter a higher form of life—man. The link with area four is provided by physiology.

### (6) **So Social Sciences**

"In the sector *So*, knowledge is being collected and systematized relative to phenomena and conditions which produce, sustain, or change the various forms of individual and group life." The link with area five is self explanatory by definition of the related sciences. The study of man naturally leads to the study of his behavior and group living.

### (7) **Ex Exeligmology**

The study of man's social behavior requires knowledge of his evolution and history. Area seven is concerned with studying the past.

### (8) **Pr Pronoetics**

Science turns to providing for the future. Agriculture, medicine and engineering help to sustain future life.

### (9) **Re Regulative Sciences** (Social Cybernetics)

Group living requires law and government. Jurisprudence and economics become the key sciences here. Pacifics, the new science of peace, provides a link with pronoetics.

### (10) **Di Disseminative Sciences**

To maintain progress from generation to generation, transmission of information must be accomplished. Library science, education, and journalism are useful in such transmutation.

### (11) **Ze Zetetic Sciences**

"The area of knowledge concerned with research activity may be called zetetics. For there is a Greek word *zetetics* which means the activity of investigation. Thus, *zetetics* is a suitable word to designate this whole area, which includes the following subdivisions:

1. Zetegeny studies the origin of sciences and zetesis as an evolutionary process.

2. Taxilogy is concerned with classification of the sciences, in particular with maintaining an inventory of sciences and discovering gaps in the system of sciences.

3. Problematology treats the selection and formulation of problems with the purpose of discovering gaps in particular sciences.

4. General methodology treats the methods of research common to all sciences and endeavors to provide a general terminology usable in all sciences.

5. Psychology of zetesis studies the abilities required for research, especially creativity.

6. Environmental conditions and incentives which stimulate zetesis.

7. Education for zetesis.

8. Organization and development of research centers.

### (12) **In Integrative Sciences**

Within this group fall the sciences which attempt to integrate other sciences to discover the relationship of the whole; to find the meaning of life. Philosophy and theology are the important sciences in this area.

The zetetic circle of knowledge is complete. The logical step from philosophy is back to area I, the arts. Between each of the areas of knowledge lie sciences that are on the borderline. These sciences, some of which were pointed out in the explanation of the various areas, are called intersciences and serve to strengthen the relationship between adjacent areas.

The individual sciences are represented in the figure by small circles. The intersciences are those drawn on the dotted borders. Each of the circles has several short lines emanating from it. When a relationship is found between two sciences, a line will be extended to connect them. One of the more significant problems facing zetetics is to find this relationship between sciences. Ultimately, the zetetic circle will resemble a large electrical field map in which lines of influence will be drawn interconnecting many of the circles in a spiderlike network. This is the explanation of why Region V was left blank. When zetetics has successfully found the interrelationship of man's knowledge, Region V can be completed.

By design of its originator, the zetetic map will be to research as the periodic table is to chemistry. When the interrelations between sciences are realized, definite gaps will appear. These gaps will enable man to develop new sciences and find new information in fields that he knows must exist.

This explanation only serves to outline the ideas contained within the map. Detailed study is required before many of the deeper and more subtle ideas are realized. The author strongly recommends more extensive meditation.

From a lifetime of research, Professor Tykociner has noted some definite pitfalls in research which zetetics will help to cure. Currently, research topics are selected rather haphazardly, but with the aid of the zetetic map, wiser choices will be indicated by the gaps presented. Researchers have the tendency to crawl into a very narrow groove thereby becoming oblivious to answers which should be obvious. If, however, they were to broaden their interests and education to include two or more related

sciences or areas of knowledge, new avenues of approach would be readily available. One of the secondary conclusions of zetetics is the need for generalized, as well as specialized education. Professor Tykociner considers the ideal research team as composed of men who are well acquainted with at least one science in each of two areas of knowledge.

Zetetics, when more widely accepted, will have a profound effect upon education. Students will be prepared either for research or for other functions in a chosen career. The two types will work in closer conjunction when employed, but in school their work will be quite different. More emphasis will be placed upon the history of great discoveries, research psychology, techniques and communication.

This significance of zetetics may not be immediately grasped: mostly because research men are so engrossed in the technical problems that they have not yet realized the world that lies beyond their laboratory. Those most in need of zetetics are educators and research foundation administrators. The first question they always seem to ask "Will it make money?" This is not the question to ask the founder of a science. That is not his problem. Basic research is not responsible for application but rather for the discovery of the information.

Joseph Tykociner has systematized a world of knowledge and formed a science. He has found new knowledge in this science and has given it to the world in his book. History has proven that basic information is seldom applied to the practical problems by the men who discovered and organized the knowledge. Witness as examples the histories of electricity, Maxwell's laws, Herztian waves, and the transistor. To ask the basic scientist for application is an unfair and irrelevant query. Joseph Tykociner has given the world a new science. It is up to others to apply it. ♦♦♦

## Voiceprint Identification

In the near future, voice patterns may be used for identification as fingerprints are today. Bell Telephone Laboratory scientist Lawrence G. Kersta has found that by using a spectrograph machine, voiceprints can be recorded on a paper drum. The pattern produced is a spectrograph that shows voice energy versus frequency. In tests, voiceprints of different people repeating the same word were recorded on cards. After shuffling, trained subjects grouped the cards according to what he thought represented the speakers. Out of 25,000 decisions, these trained people were over 97 per cent correct.



# ENGINEERS WHO AREN'T

By Larry Balden, EE '64

**This article is the second in the series written  
by Illinois Engineering students in summer industry.**

This summer, I worked for a company which hires a great many engineering graduates; yet, I had little use for my slide rule. I was among the ranks of *engineers who aren't*. Was I a fish out of water? Not a bit, and I'll explain why since other engineers may find themselves in the same situation in a summer job or full-time employment.

First, how was my job different from jobs of *engineers who are*? These genuine ones can be found in the Engineering Department where they will be concerned with research, design, and development of new systems or elimination of problems with established systems.

I was in no way connected with that department. Instead I worked for the Plant Department of a telephone company, which is responsible for maintaining the physical facilities they own. This encompasses so much equipment, such as lines and cables, switching offices, and microwave relay stations, that the Plant is divided into two parts, "inside" and "outside." I worked in "inside," which takes care of housed facilities consisting mainly of toll (long distance) and local switching systems.

You may still think that my gills were getting dry, because this doesn't seem yet to be akin to the engineer's natural habitat. Even so, many of the

management personnel for whom I worked were engineers, primarily electrical and mechanical. My boss for the first few weeks was a switching office foreman who had gained his degree in electrical engineering about a year and a half before. His own immediate superior was also an engineer, as were many of the other management people. There is a simple reason for their presence: the complexity of the equipment requires the technical background of an engineer.

There was a different reason for my presence, since I was certainly not in management. My work was similar to that of an apprentice. The only difference was that I was not seeking mastery of the skills; I was only learning something about many jobs in order to find out what was involved in each and to get an idea of the overall operation. I learned several of the skills of the craftsmen. For instance, I was taught how to make the various cross connections necessary to get a new subscriber's telephone into the switching network. After studying the circuit prints and books describing their operation, I was able to repair component switches. One special assignment was to find the reason for a certain annoying click in the telephone receivers and recommend a way to stop it. This was the closest I came to engineering all summer.

While the work seemed at times trifling, I found it absorbing as well as good experience. Also my job paralleled the company's regular training plan, which is known as the Management Assistance Program, or MAP. It is the type of rotational training many young graduates will go into. But MAP is more than the usual keep-moving-until-you-find-your-niche system. It is meant to give the trainee an overall view of the company. My job was similar to MAP in that I also got to see the operation from the point of view of the people I may later supervise as do the trainees in that program.

To this end, the trainee spends two weeks in each department as a regular employee. For instance, he may be a service representative in the Business Department, or he may be a craftsman in the Plant, or he may work as an operator. The stint as operator is the one they tell about when they are out of the program. The trainee's deep voiced, "Operator" is met by such replies, "No, I want the operator," or, "Oh my, are the girls on strike again?" or just by silence and a click.

During this round, the new man meets many of the situations and problems of the regular employee and gains respect for his position. Next, the trainee rotates through the departments again for a longer period of time in a supervisory position, and the problems he encounters are different. He has a "coach" to whom he can address questions. There will be frequent conferences at which the coach will discuss the man's progress and offer suggestions to help him along. One such trainee worked as "frame" foreman in the main switch office with me. The "frame" is where the switching system and the lines out to all the telephones meet. Every time a phone is installed, removed, or changed, the cross-connections on the frame must be suitably altered also. The frame foreman in a large office is in charge of the framemen who do this work. It is his responsibility to see that the service orders are worked and recorded. When an event like the Illinois State Fair requires hundreds of phones to be installed, he must coordinate the work. In all his training, the new man must meet, work with, and obtain the cooperation of many people. Experience he gains is valuable whether he decides to take advantage of the opportunities in management or to work among the *engineers who are*. ♦♦♦



# DEEP SEA DIVERS TO SPACEMEN

**DIVERSITY**—U. S. Rubber makes 33,000 products in 1,200 lines that are used by almost everybody, from deep sea divers to spacemen. In our 22 divisional laboratories or in our Central Research Center, there is a challenge for almost any technical or engineering specialty.

**LEADERSHIP**—Our research sets the pace for the industry. More than 100 years ago, U. S. Rubber made the first manufactured vulcanized rubber product; more than 60 years ago, the first pneumatic automobile tire; more than 40 years ago, the first research on synthetic rubber. Today we contribute our resources and skills to atomic research, to oceanography, to the latest design in space stations, to hundreds of other exciting projects.

**VITALITY**—U. S. Rubber uses to the fullest the professional skills of its 2,000 engineers and research personnel, encourages individual responsibility in an atmosphere of freedom. Our research and development people, in the last five years, have obtained 457 patents, more than our two largest competitors combined.

**OPPORTUNITY**—U. S. Rubber recognizes the importance of our technical staff, knows that the answer to tomorrow's problems is already in the minds of its engineers today. "U.S." rewards individual contributions. Many in our top management started as engineers or technicians with the company. The president of U. S. Rubber is a chemical engineer, several vice presidents hold engineering or technical degrees.

**STABILITY**—U. S. Rubber is one of America's 50 largest industrial companies, with more than 119 years of industrial experience, operating 74 plants at home and abroad. We are a polymer industry with less than half our business in tire manufacturing. U. S. Rubber is one of the nation's largest textile manufacturers and leading chemical producers. "U.S." provides good working conditions for more than 40,000 employees in the United States, another 30,000 abroad.

Inquire about a career with "U.S." Our recruiters will be visiting your campus soon. Sign up for an interview at your Placement Office.



**United States Rubber**

An Equal Opportunity Employer

1230 AVENUE OF THE AMERICAS • NEW YORK 20, N. Y.



Calvin W. Emerson, Purdue BSME '60, MSME '62, inspects hollow air-cooled turbine blades after a test run of a first-stage prototype wheel in a turboprop engine power section. Emerson is one of numerous young engineers engaged in applied research on advanced gas turbine engines now under development by the Allison Division of General Motors. Blades of the type shown in the wheel have played a major role in boosting horsepower as much as 63% in development engines. These air-cooled blades operate in higher inlet gas temperatures with a lower blade surface temperature than uncooled blades, making possible improved fuel consumption as well as increased horsepower output.



● **ADVANCED TURBINE ENGINE DEVELOPMENT**—Allison, world leader in the design, development and production of turbo prop engines, is extending their capabilities to meet changing military needs.

Current programs greatly advancing the state of the art include developments for V/STOL applications and programs to maximize fuel economy and range through air cooled turbines and high temperature regenerative cycles.

And, in other fields, first and second stage rocket engine cases designed and produced by Allison for Minuteman have achieved a 100 per cent reliability record. Allison's steadily growing competence in the field is reflected in the forward strides made in titanium and glass filament-wound ICBM cases. Also, Allison has developed a highly efficient regenerative liquid metal cell that may point the way to a powerful, yet compact, electrical system for space-age applications.

Atomic Energy Commission's announcement of negotiations with Allison as prime contractor for development of MCR (Military Compact Reactor) also creates long-range opportunities in the nuclear field. Perhaps there's a place for you in the creative environment at Allison. Talk to our representative when he visits your campus. Let him tell you first-hand

what it's like at Allison where *"Energy Conversion Is our Business."*

**Allison**

THE ENERGY CONVERSION DIVISION OF  
GENERAL MOTORS, INDIANAPOLIS, INDIANA

*An equal opportunity employer*

# Clean Hi-Fi Sound

...from a sewer pipe

by Jim Walters EE'65

Last June, an article in *Popular Electronics* entitled "Clean Sound from the Drain Pipe 8" gave plans for building a new type of hi-fi enclosure at a cost under \$10.00. Since the cheapest finished wood enclosures cost a minimum of \$30 each, with kits about \$20, this was an interesting prospect. However, one just doesn't put a sewer pipe in his living room without first giving it some consideration.

Meanwhile, I persuaded a friend into letting me build two of these units for him. He liked the low cost and efficient services afforded by the heavy sewer pipe enclosure. Its 100 pound weight greatly reduces distorting vibration so often found in most wood competitors. Belonging to the bass reflex family, this tile enclosure affects only the low end of the sound spectrum (300 cycles per second down). In this range, the bass vibrations from the front and rear of the speaker tend to cancel—leaving weak bass response.

This bass reflex enclosure, by means of tuned cavities and bass port, reduces this resonant frequency intensity and delays the phase of the bass coming from the rear of the speaker to boost that from the front. The listener, then, enjoys music that neither lacks bass nor booms when heard with the rest of the orchestra sounds.

Enough of theory, let's gather the supplies. The three foot lengths of sewer pipe come in two standard inside diameters: eight and ten inches. To give

maximum resonant volume, the ten inch is preferable. Its cost at a cement yard is about \$3. The wood for the center filter and ends can be obtained at a lumber yard for about \$1.50. The acoustical material (fiber glass insulation) can be picked up at the same time for \$2.

The metal or plastic funnel, to be used as a treble diffuser, costs 25c at the local hardware store. The plaster of paris for adding ballast to the treble deflector and a new non-hardening compound for mounting the end assemblies on the sewer pipe cost \$1. This compound seals ruggedly, yet can be broken whenever the speaker is to be changed. Most "dime" stores carry the 3' length of vinyl-covered foam plastic weatherstripping for filter gasket. The miscellaneous items, such as glue, wood screws, tacks, brads, and additional material for padding can probably be found around the basement, if needed.

With the necessary supplies on hand, it's time to start cutting the wood. The outside dimensions (see Fig. 1) for the circular pieces labeled *A*, *B*, *C*, and *D* are to fit the irregularities of the tile. Marking is best accomplished by setting the pipe on the wood and following the pipe contours with a pencil (parts *A*, *B*, and *C*). Part *D* can be copied from *C*. The speaker and bass port holes through parts *C* and *A* should be cut as specified by the drawing. Although there are many ways to make circular cuts in wood—lathe, drill, coping saw—an easy way is to drill a  $\frac{3}{8}$ " hole in the wood outside the piece to be cut and use it as the starting place for an electric saber saw. The circular cuts can be completed in about two hours. Part *B* should be cut smaller than marked to permit attaching weather stripping. The rectangular parts labeled *E* can be easily cut with a rip saw.

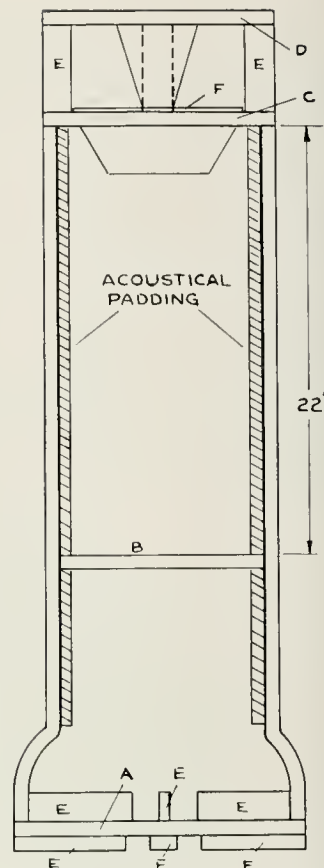

## BILL OF MATERIALS

- 1 3' section of 10"-i.d. sewer pipe, concrete or glazed tile.
- 1 15x50" sheet of  $\frac{3}{4}$ " plywood (for parts A, B, C, D).
- 9 1 $\frac{1}{2}$ "x4 $\frac{1}{2}$ " pieces of  $\frac{3}{4}$ " pine (for parts labeled E).
- 1  $\frac{1}{4}$ "x11" piece of  $\frac{1}{2}$ " pine (for funnel support F).
- 1 22x30" sheet of 1" polyurethane foam plastic (for lining above filter).
- 1 15"x30" sheet of 1" polyurethane foam plastic (for lining below filter).
- 1 3' length of vinyl-covered foam plastic weatherstripping (for filter gasket).
- 1 5 $\frac{1}{2}$ "x36" length of grill cloth (for side grill).
- 1 Package of "wood" tape (trim).
- 1 4" or 5" plastic or metal funnel (for treble diffuser).
- 1 8" PM speaker

Misc. Plaster of Paris, glue, wood screws, tacks, brads, and wire.



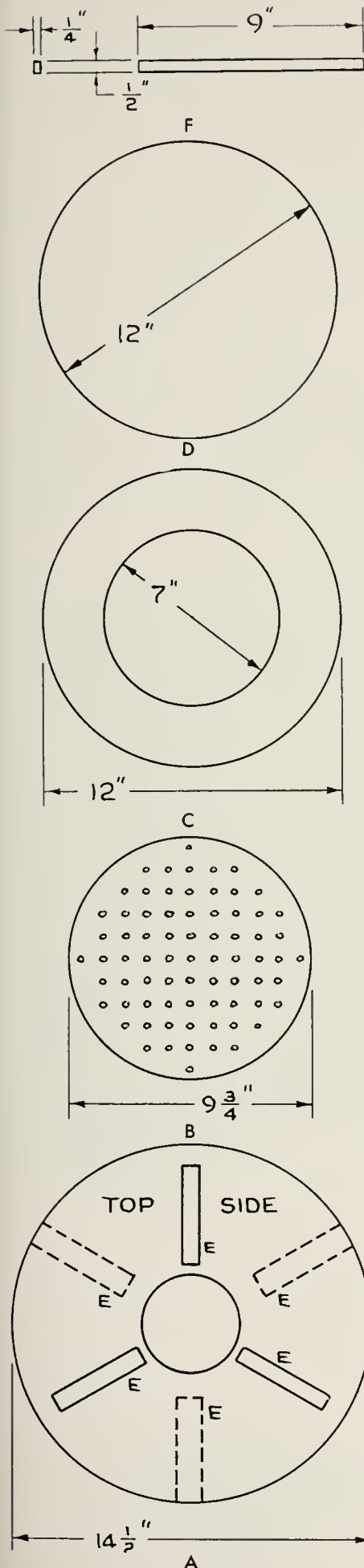

## TOP ASSEMBLY

When all the parts are completed, assembly can be started with either the top or bottom, but let's start with the latter. After carefully noting how part *A* fits under the pipe, mount three *E* blocks to the bottom side with glue and two  $\frac{3}{4}$ " wood screws as shown. Set the pipe, small end down, on the floor. Place part *A* on the pipe. Set an *E* block through the 4" hole into place as shown. Carefully holding *E* block in place, remove it and part *A*—being careful not to move *E*'s position relative to *A*. Mark the position of part *E* on bottom *A* with pencil. Countersink two holes in block *E* to within  $\frac{3}{8}$ " of other side, to mount it as is shown.

Using two  $\frac{3}{4}$ " wood screws and glue, attach block *E* to top side of part *A*. Follow same procedure for other two *E* blocks, being sure to separate them by 120 degrees.

To construct *B*, locate the center. Draw two diameters at right angles on it. Construct parallel lines on both sides of each diameter at 1" intervals. Using newly found center, draw a 4" radius circle. At each crossing of two perpendicular lines within the circle, drill a  $\frac{1}{4}$ " hole. Drill a total of 50 holes. To prevent shattering of plywood on opposite side of drilling, set a scrap piece of lumber on this side. After the holes are completed, nail a strip of vinyl-covered foam plastic around filter and push it into the pipe  $15\frac{1}{4}$ " from flared end.

Run a 10' piece of 75 ohm household wire through any outside hole of the filter.

Cut a piece of polyurethane foam plastic or acoustical material for bottom inside of pipe. Mount it. The natural tendency for such material to straighten will hold it in place. Set the bottom *A* on pipe. Drill a  $\frac{1}{4}$ " hole in it for speaker wire and pull it through. Carefully turn enclosure over onto flared end.

Cut a piece of acoustical padding for top inside of pipe. Material should extend from filter to upper edge of pipe

around the full circumference. After pulling sufficient speaker wire from bottom to allow a 1' excess over pipe's top, mount the acoustical padding.

For constructing the top assembly, carefully note how part *C* fits on pipe. Since it is not perfectly round, reversing this part will cause a misfit. To resume construction, cut part *F* and drill a  $\frac{1}{8}$ " hole in its center. Using two  $\frac{1}{2}$ " wood screws and glue, fasten part *F* on part *C* so that the middle hole of *F* corresponds to center of part *C*.

Cut off the lower tip of the funnel, leaving only the unbroken flared portion. Fasten it, small end down, to center of part *F* with a long bolt, washer, and nut—as shown. Fill funnel with plaster of paris. It will keep the funnel from vibrating and adding unwanted noises to speaker response. While the plaster of paris is setting, measure the distance from the upper edge of *C* to the top of the funnel. Cut the remaining *E* blocks to this length. After the plaster of paris has set, position the *E* blocks between *C* and *D* as shown. Fasten the top assembly together with 1" wire nails and glue.

To complete the top, mount the 8" speaker with four  $\frac{1}{2}$ " wood screws. It can be of any type since the resonant frequency of most 8" speakers is about the same. My speaker cost \$5. The quality of a speaker is generally proportional to the cost. As much as \$30 can be paid for an 8" to gain better fidelity.

To finish the upper assembly, stretch the grille cloth around its sides. Nail the upper and lower edges of cloth to parts *D* and *C* with  $\frac{1}{2}$ " nails through wood tape.

At this point, the top and bottom assemblies are ready to be attached to the pipe. In the bill of materials my description of sealing compound is vague because to change speakers, the top seal must be broken. If a permanent material were used, this could not be done without perhaps damaging the assembly. Yet these seals must be air tight or the effect of the enclosure is greatly reduced. On my two enclosures, I finally sealed them with a soft permatex material. It makes an air tight fit without becoming permanent. Another means of attaching the assemblies is with a plaster that sticks to wood and stone. This seal is presumably permanent. This substance is ideal if the speaker is not to be changed.

The final step is to connect the speaker of the top assembly, push the excess wire behind the acoustical padding, and seal the two assemblies by whatever compound is desired.

After the sealer has set, connect the speaker leads to your hi-fi amplifier relax, and enjoy the clean cut sounds coming from your sewer pipe enclosure. ♦♦♦



# Engineers

*In Choosing a Career,  
Consider these  
Advantages—*

**Location:** Fisher is basically an "Engineering" company with 1,500 employees located in a pleasant midwest community of 22,000. It's less than 10 minutes to the Fisher plant from any home in Marshalltown.

**Type of work:** You'll become a member of an engineering team that has produced some of the outstanding developments in the field of automatic pressure and liquid level controls.

**Growth:** Fisher's products are key elements in automation which assures the company's growth because of the rapid expansion of automation in virtually every industry.

**Advancement:** Your opportunity is unlimited. It is company policy to promote from within; and most Fisher department heads are engineers.

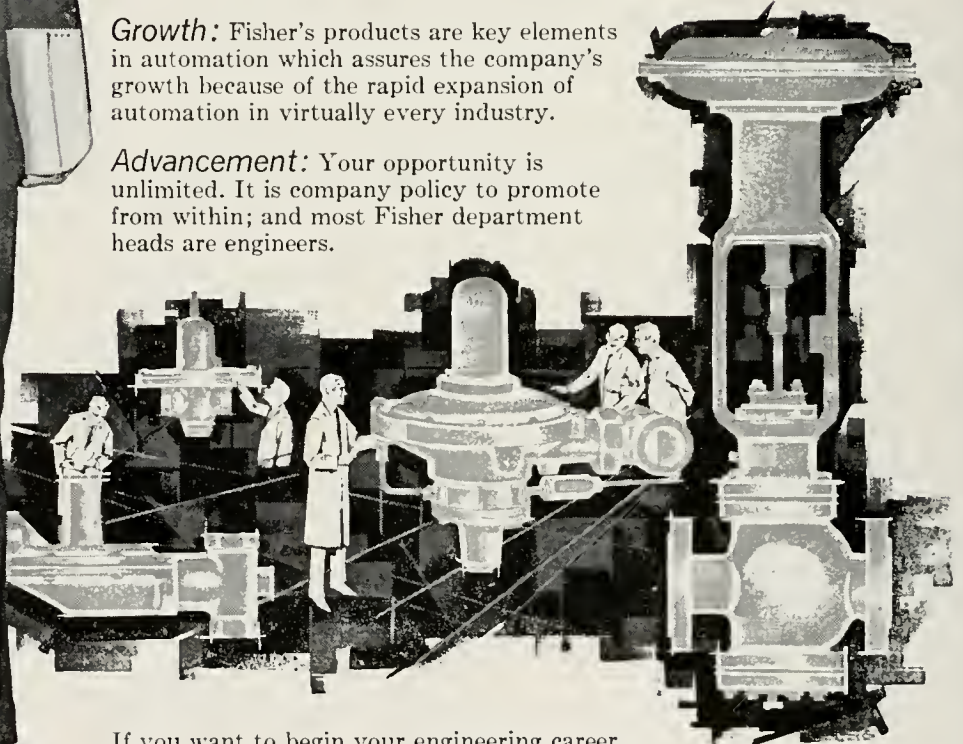

If you want to begin your engineering career with one of the nation's foremost research and development departments in the control of fluids, consult your placement office or write directly to Mr. Cecil Johnson, Chief Engineer, FISHER GOVERNOR COMPANY, Marshalltown, Ia.

*If it flows through pipe  
anywhere in the world  
chances are it's controlled by...*





## Advantages of working for a large company:

1. Formal training program.
2. A variety of available positions.
3. Wide choice of geographic locations.
4. Greater job security.
5. Extra benefits—financial aid for advanced studies, retirement plans, hospital plans, life insurance.

## Advantages of working for a small company:

1. Fewer steps to the top.
2. Individual attention by top management.
3. Greater growth opportunity.
4. Earlier responsibility.
5. More opportunity to handle complete projects.

## Why B&W can offer you the advantages of both

For every college graduate-to-be there is usually an optimum size company where he will find his greatest opportunity.

For many students, this company could be Babcock & Wilcox.

Babcock & Wilcox is a large, progressive company. For example, 1962 sales were over \$300 million. Every year B&W invests many millions of dollars in research and development. B&W has all the advantages of a large company: formal

training program, wide variety of job openings (17 plants in 8 states), plus the security and benefits of a large, 95-year-old organization.

Babcock & Wilcox also can be considered a small company. There are 150 larger industrial companies in the U.S. Growth opportunities are tremendous. Only 60 bachelor-level students will be hired in 1963. This select group will be given an opportunity to work on important projects at an early stage in their careers.

If you are interested in the size of the opportunity rather than the size of the company, your placement office has a new booklet that describes openings for graduate and undergraduate engineers and scientists, including E.E., Ch.E., M.E., Met.E., Cer.E., Nuc.E., chemists and physicists. Or write to J. W. Andeen, The Babcock & Wilcox Company, 161 E. 42nd St., New York 17, N. Y.

**Babcock & Wilcox**

# NEWS AND VIEWS

at the

## University of Illinois

Edited by Gary Daymon, EE '64

### U. of I. Railroad Rail Research

Although rail travel has always been one of the safest modes of transportation, American railroads have throughout the years sought ways of making it even safer. That safety has been made possible by a continuous program of research. A great deal of this research has been and continues to be done at the University of Illinois.

Although the University's early research on track and wheel problems brought important contributions to railroad efficiency and safety, one of railroading's most distressing problems continued to be the frequency of rail breakage. In 1931 rail breakage, which had been increasing for more than two decades, had reached 12,000 rails a year on American and Canadian railroads. U. of I. researchers found that the breaks were caused by microscopic "shatter cracks" which were hidden deep inside the rail head. They found that these shatter cracks resulted from too rapid cooling of the freshly made rails. From this finding the U. of I. engineers developed "controlled cooling" of the new rails. The importance of this research finding can be appreciated when one realizes that of the millions of miles of track that criss-cross the continent, not a single rail made by the controlled cooling method has since failed from a shatter crack.

Since the shatter crack problem has been solved, U. of I. researchers have turned their attention to other types of rail failures and are continuing to make progress toward safer and stronger rails. Some of the current research is reported in Reprint 63, "Progress Reports of Investigations of Railroad Rails," by Professor R. E. Cramer. It is available for fifty cents from Engineering Publications, University of Illinois, Urbana, Illinois.

*Engineering Outlook*

### Some People Call It Rust

Each year corrosion costs the public \$6.5 billion a year. The University of Illinois Cathodic Protection Laboratory, under the Department of Mining, Metallurgy, and Petroleum Engineering, has facilities for the investigation of conditions under which corrosion occurs and its control by cathodic protection measures.

Corrosion is an electro-chemical process in which metal, going from the solid to ionic state, loses electrons which produce a direct (d-c) current. A solution to this expensive problem is cathodic protection: a method of supplying electrons to a corroding metal system for the purpose of reducing or eliminating the corrosion current. Such protection can be furnished in two ways: by the use of a rectifier furnishing an opposing d-c from an a-c source, or by the use of sacrificial (more easily ionized) anodes of magnesium, zinc, or aluminum. Either method can protect pipelines and cables indefinitely, while unprotected structures may fail within two years after construction.

One of the current interests of the Cathodic Protection Laboratory staff is the problem faced by companies that transport gas by pipeline over long distances. In areas where the pipelines parallel or run near high-tension power lines, they lie within the electric fields produced by the power lines—a circumstance that may prove to aggravate the ever-present natural effects of corrosion. Professor Walter H. Bruckner, technical director of the Laboratory, is presently studying the possibilities of giving such pipelines cathodic protection by using rectifiers to convert the a-c electric fields to the d-c that will resist corrosion. If it works, the pipeline companies will get their cathodic protection without paying for the power involved.

*Engineering Outlook*

### Tech Writer Receives National Honors

Larry Druffel, one of TECHNOGRAPH's ace writers, left for New York City January 27th to accept a \$100 prize and award certificate for his winning student paper in the nationwide American Institute of Electrical Engineers' Contest. His paper was written on the electronic simulation of human hearing, and it discussed such possibilities as telephone calling by voice rather than by mechanical dialing.

Larry is graduating this month in electrical engineering, and the TECH staff and his many friends congratulate him on his prize paper as well as on his

excellent college record. Larry is a prime example of a person who has a will—and therefore a way. During his 4½ years of college he has earned all his expenses—working part time as a laboratory technician, salesman, waiter, and summer truck driver.

During his junior year he became interested in technical writing. He enrolled in several technical writing courses offered by the college of Engineering and subsequently joined the TECH staff. Although his semester schedule often included 20 hours of courses as well as part-time employment, he has written extensively for TECH—the article on Zetetics in this issue (page 10) is an excellent example. This particular article has been submitted to *Scientific American* for consideration.

### Prof. Coleman Honored

Prof. Paul D. Coleman, head of the ultramicrowave research group in the University of Illinois Department of Electrical Engineering, has been named a Fellow of the Institute of Radio Engineers. This is the highest membership grade offered by the IRE, and it is bestowed only by invitation of those who have made outstanding contributions to electronics, radio or allied branches of engineering and science.

Prof. Coleman was cited for his contributions in submillimeter wave generation. The research group under his direction at Illinois has been a world leader in ultra-high frequency research, using the University's Illiac high-speed computer and verifying results experimentally. His group has utilized the phenomenon known as Cerenkov radiation which may lead to new devices for generating ultra-high frequency radio waves.

Cerenkov radiation, discovered by a Russian scientist in the early 1930's, results when a charged particle passes through a substance at a speed greater than light can pass through it. It produces an eerie blue glow in nuclear reactors, but not all Cerenkov effects are visible.

The radiation is at frequencies between radio microwaves and the far infrared which leads into visible light. This is the last unused gap in the electromagnetic radiation spectrum which includes radio, x-rays, light, heat and similar phenomena.

Prof. Coleman has been at Illinois since 1951. This year he is on leave serving at Stanford University as visiting professor. He was among 76 leading electronics engineers and scientists from the United States and five other countries named Fellows at a recent meeting of the IRE board of directors. ♦♦♦



# MACHINE THAT DIAGNOSES ITS OWN FAILURES



The dictionary refers a maintenance technician to a defective gas tube Circuit Pack in a model of the electronic switching system. Thousands of miniature tubes like these switched telephone calls at Morris, Illinois, during an experimental trial of the system.

An electronic telephone switching system that diagnoses its own failures when they occur and tells maintenance men where to look for the trouble in a "dictionary" it helped "write" has been developed by Bell Laboratories. The system also discovered methods of running itself that its human programmers had not considered.

S. H. Tsiang, of the Electronic Switching Laboratory, developed the dictionary for a recently-completed trial of an experimental Electronic Central Office at Morris, Illinois. The dictionary was written for the system's most complex part, a central control unit containing 6,500 transistors and 45,500 diodes. Tsiang described the dictionary's preparation in a paper presented at the Summer General Meeting of the American Institute of Electrical Engineers.

The dictionary helps insure the continuous operation of the electronic switching system, which must be able to handle telephone calls at any time and run 24 hours a day without more than a few thousandths of a second lapse. When the Bell System's first commercial Electronic Central Office begins opera-

tion in 1965 in Succasunna, N.J., every control unit will have a duplicate standing by in case any component fails. The duplicates would then take over automatically and, in the thousandths of a second between calls, run diagnostic tests on the defective unit.

The system prints test results on a teletypewriter. A maintenance man checks these results in the dictionary, which tells him the Circuit Pack to replace (Components are mounted on small, easily removable units called Circuit Packs.) This way, he usually can locate and clear up trouble in a few minutes.

To prepare the dictionary for Morris, Tsiang had the system programmed to make over 900 different tests on each of 50,000 simulated failures. The system recorded the test patterns for each failure and the identity of the faulty components. Then a computer sorted the patterns in numerical order and printed them in a four-volume dictionary totaling 1,250 pages.

Bell engineers expect a dictionary of this type to locate 90 per cent of the component failures that may develop at

the Succasunna office. In the meantime a duplicate of the first commercial Electronic Central Office is being constructed at the Laboratories' Holmdel location. Engineers there will continue to improve diagnostic techniques and the maintenance dictionary.

Programmers gave the system many alternative ways of restarting itself in millionths of a second if a vital component should fail. "However, we noticed the system using a combination we had not programmed into it," reports R. Ketchledge, Director of the Electronic Switching Laboratory. "So we investigated and found we'd accidentally connected a wire to an open terminal. This should have caused the system to stop when it needed to use this wire. But it didn't. It combined several programs into one of its own and avoided using the open wire. This 'motivation' apparently results from our providing the system with many alternative programs aimed at the same result—to keep running" ♦♦♦

*(Reprinted from the Bell Laboratories Record.)*



a  
message  
to  
graduating  
engineers  
and  
scientists

AT PRATT & WHITNEY AIRCRAFT...

**YOUR EYES CAN BE ON THE STAR**

**SPECIALISTS IN POWER . . . POWER FOR PROPULSION—POWER FOR AUXILIARY SYSTEMS.  
CURRENT UTILIZATIONS INCLUDE AIRCRAFT, MISSILES, SPACE VEHICLES, MARINE AND INDUSTRIAL APPLICATIONS.**



## PUT YOUR FEET MUST BE ON THE GROUND

The glamour and excitement of space age programs often obscure a fundamental fact. It is simply that farsightedness must be coupled with sound, practical, down-to-earth engineering if goals are to be attained. This is the philosophy upon which Pratt & Whitney Aircraft's position as a world leader in flight propulsion systems has been built.

Almost four decades of solid engineering achievement at Pratt & Whitney Aircraft can be credited to management's conviction that basic and applied research is essential to healthy progress. In addition to concentrated research and development efforts on advanced gas turbine and rocket engines, new and exciting effects are being explored in every field of aerospace, marine and industrial power application.

The challenge of the future is indicated by current programs. Presently Pratt & Whitney Aircraft is exploring the areas of technical knowledge in *magnetohydrodynamics . . . thermionic and thermo-electric conversions . . . hypersonic propulsion . . . fuel cells and nuclear power.*

If you have interests in common with us, if you look to the future but desire to take a down-to-earth approach to get there, investigate career opportunities at Pratt & Whitney Aircraft.

To help move tomorrow closer to today, we continually seek ambitious young engineers and scientists. Your degree? It can be a B.S., M.S. or Ph.D. in: **MECHANICAL • AERONAUTICAL • ELECTRICAL • CHEMICAL and NUCLEAR ENGINEERING • PHYSICS • CHEMISTRY • METALLURGY • CERAMICS • MATHEMATICS • ENGINEERING SCIENCE or APPLIED MECHANICS.** The field still broadens. The challenge grows greater. And a future of recognition and advancement may be here for you.

---

For further information regarding an engineering career at Pratt & Whitney Aircraft, consult your college placement officer or write to Mr. William L. Stoner, Engineering Department, Pratt & Whitney Aircraft, East Hartford 8, Connecticut.

---

# Pratt & Whitney Aircraft

CONNECTICUT OPERATIONS EAST HARTFORD, CONNECTICUT

FLORIDA OPERATIONS WEST PALM BEACH, FLORIDA

DIVISION OF UNITED AIRCRAFT CORP.  
**U  
A**

An Equal Opportunity Employer

# ION

# PROPULSION

By Art Becker, EE '66

## *The Force of the Future*

The concept of electric propulsion is a relatively recent addition to the store of principles which will make possible the exploration of space by both manned and unmanned vehicles. The attention given to the development of the idea is not common for a newcomer to technology and is due to the potential which systems of electric propulsion are indicating they possess. In the resistance-free environment of outer space, these systems will have a usefulness of which the current theoretical applications are only samples. Such tasks as control of satellite attitude and adjustment of satellite orbit, and perhaps the furnishing of power for lunar ferries, are examples of the proposed possibilities. Flight tests are planned within the next six months and will probably take the form of an electric propulsion engine riding as an extra on a large satellite.

Electric propulsion systems are of four distinct types: electromagnetic, or plasma, systems; electrothermal, or arcjet, systems; electrostatic, or ion, systems; and heavy-particle systems. The ion systems receive the greatest part of the attention given to the field of electric propulsion; however, brief definitions of the three other types will be helpful in gaining a clearer meaning by contrast, of ion propulsion. The four lines are very similar, as they all operate on the same basic principle.

All four systems provide thrust by the acceleration of charged particles. Differentiating characteristics lie in the nature of the propellant and the manner of acceleration.

The plasma engine operates through the dual action of electric and magnetic fields on a neutral plasma, which attains a velocity high enough to enable

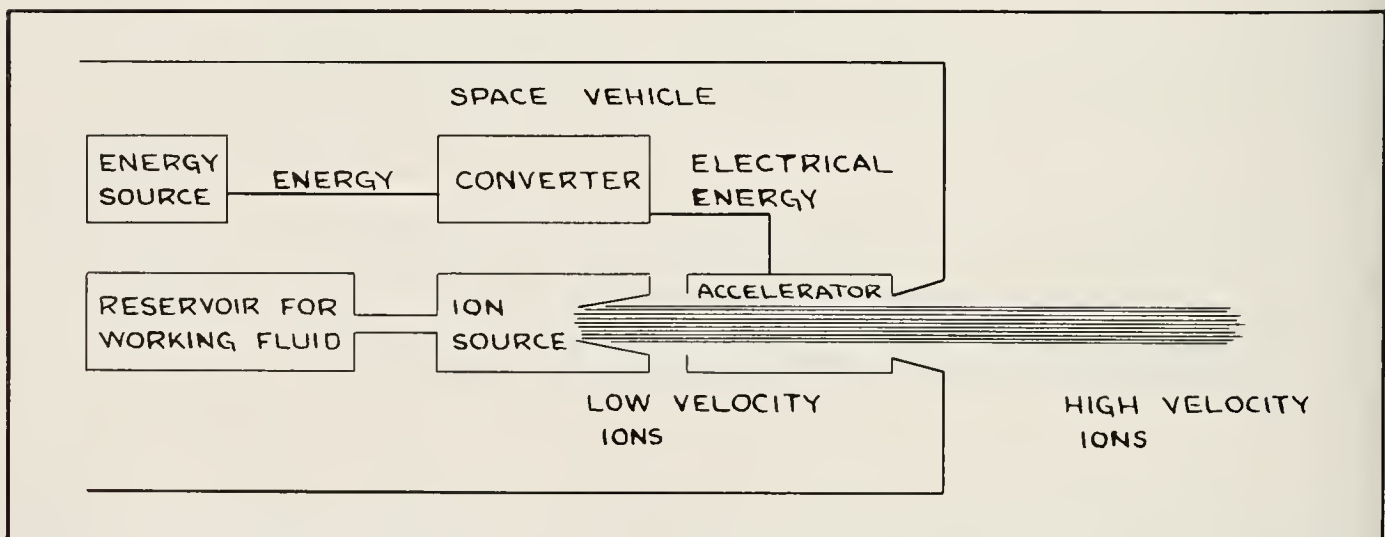

Figure 1



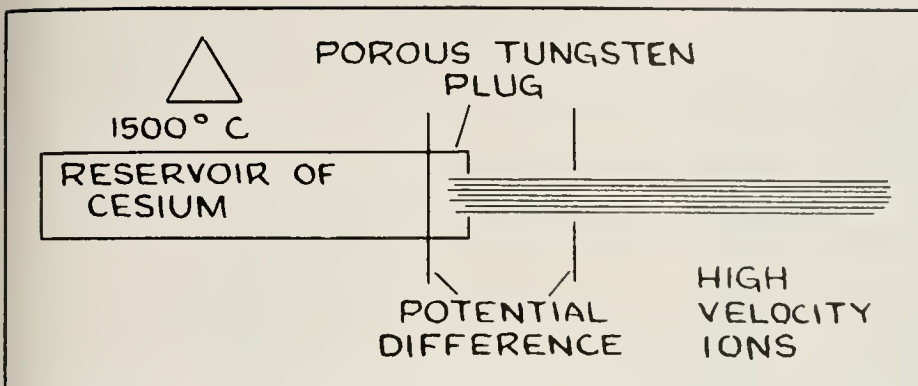

Figure 2

the plasma to act as a thruster. Electromagnetic forces in a plasma engine act on the electrons and ions in the plasma, but collision frequencies between charged particles and neutral atoms are very high so that ions, electrons, and atoms are streamed through the nozzle at a nearly uniform velocity.

Electrothermal (arcjet) rockets use electric heater elements to give a propellant, commonly hydrogen, the necessary high velocity. Electrothermodynamic action, the physical process within such an engine, is not yet fully understood, and electrothermal systems are beset with problems, such as the rapid erosion of electrodes and nozzle walls.

Heavy-particle systems are very close relatives to the ion engines and, in fact, are so nearly identical to ion engines that research on the two types is usually carried on simultaneously. An example of such a joint program is in progress at the University of Illinois Charged Particle Laboratory. Heavy-particle engines as their name suggests, use particles of greater mass than the atomic ions found in ionic systems. Charged colloids, charged spray or dust particles, and molecular ions are common heavy-particle propellants.

The operation of the electrostatic or ion engine consists of two main processes: 1) production of the ions, and 2) acceleration of the ions. The working fluid, which very often is cesium, is stored in a reservoir, from which it is fed into the ionizing chamber. Ions of low velocity are emitted from the chamber, travelled through an accelerator, and streamed out the nozzle at high velocity (approximately 30 km/second.) Energy, possibly nuclear, is converted into electrical energy before it is utilized as a power supply for the accelerator. (Figure 1).

Ions are produced in most systems from one of two sources. The porous-plug ion source is comprised of a reser-

voir, held at high temperature (1500° C), capped with a porous disc or plug. Shapes of porous-plug ionizers differ greatly: arrays of small buttons, scalloped discs, and long, narrow slabs are being investigated. A potential difference is maintained between the plug and a second, ring-shaped disc; this arrangement acts as an accelerator for ions produced by the passage of fluid through the porous plug. Cesium is the most common working fluid, with tungsten used as the plug. (Figure 2). The second method of producing ions is by electron bombardment of a fluid. A reservoir filled with mercury vapor is surrounded by a magnetic field. A hot filament within the reservoir gives off electrons and accelerated ions pass out through the rear of the chamber. (Figure 3). One limitation of this type of source is the short life of the filament. The ions produced in both systems are positively charged; in order to keep the space vehicle electrically neutral, a beam of electrons is directed along with the ion beam.

Thrust of ion engines is on the order of a few thousandths of a pound; therefore ion engines can never act as earth-launched boosters, since a thrust-to-weight ratio of at least one is required

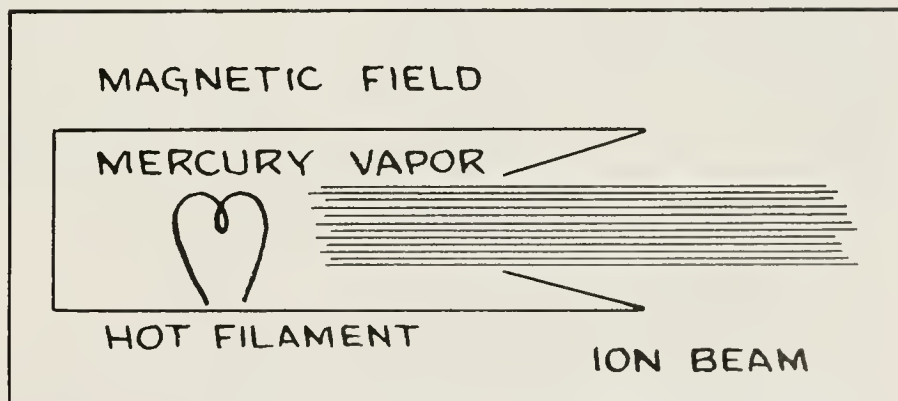

Figure 3

of a vehicle before it can leave the earth's surface. Performance statistics on most of the ion engines remain classified; however, most of these figures are now higher than was believed possible a few years ago. The state of development of current ion engines is advanced enough for their use in modest primary missions.

The remnant of effort yet to be given the electrostatic systems before a flight test takes place will consist in making engineering refinements on the support systems of the engines. The fact is that the pumps, cooling circuits, and other secondary units actually have a shorter life than the engine itself. The expense and difficulty involved in running ground tests in vacuum chambers in order to delay the death of these parts is one more argument in favor of conducting future tests in outer space.

A recent study by the Jet Propulsion Lab indicates that a full 50% of proposed planetary and interplanetary missions cannot be accomplished by conventional systems carried by conventional chemical rockets of the Nova type. Forty percent cannot be accomplished by nuclear-heated systems launched by the Saturn C-1. However, most missions can be performed by electric systems—probably electrostatic—boosted by the same Saturn C-1. The consideration given to developing electric propulsion is not being wasted. However, great strides must be made before such impressive potential can be realized. The long-range, heavy-payload probes will require an engine of at least 50 kw; present systems are on the order of 1 to 3 kw.

The first mission that will be performed by an electric propulsion system will probably be the station-keeping, preserving of orientation, of a satellite. The next step will be a probe of the Van Allen radiation belts by an electrically-propelled vehicle. Modest space errands such as these are only the beginning. ♦♦♦

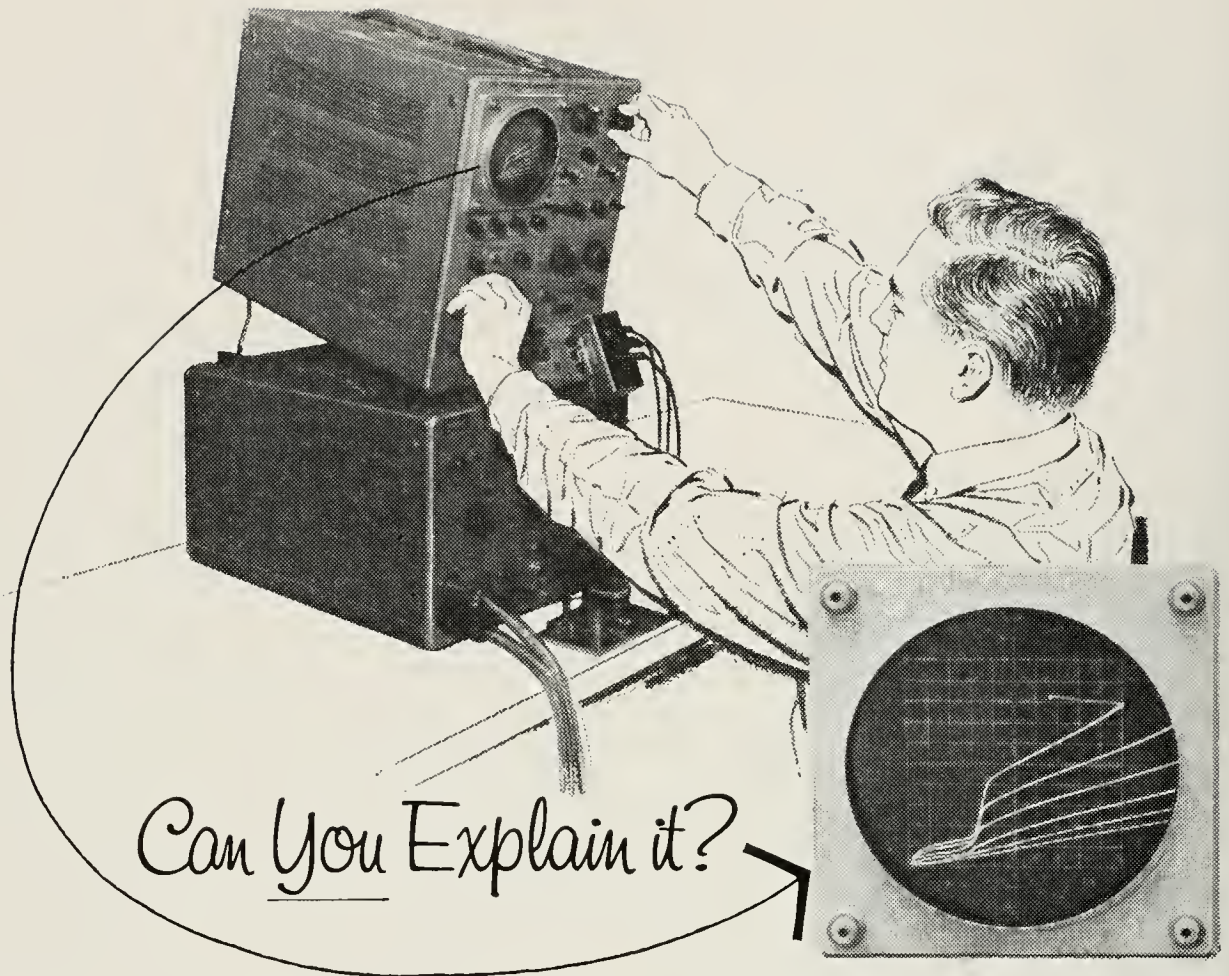

When a transistor performs like this on a curve tracer, we like to know why. Sometimes the answer is obvious. Then again, we may find it not so easily explained. This our semiconductor device people like. They enjoy sinking their teeth into a knotty problem and sticking with it till they shake out the answer—and it usually doesn't take long at Delco.

Why? Easy.

When you toss a problem to a group of talented men . . . provide the necessary research tools . . . in an environment that encourages personal initiative and achievement . . . you can't help getting results. This combination has helped build a position of leadership for Delco in the development and production of semi-conductor devices.

We intend to keep it that way—through expanding facilities and fresh talent.

Our new R&D center—125,000 sq. ft.—houses laboratories equipped with the latest in sophisticated research facilities. Our new semiconductor manufacturing center—226,000 sq. ft.—scheduled for operation this June, will provide an expanded capability in the production of silicon rectifiers. All of which adds up to new opportunities in research, development and production of silicon rectifiers.

solid state electronics ●



DELCO RADIO DIVISION OF GENERAL MOTORS  
KOKOMO, INDIANA

• **SEMICONDUCTOR DEVICE DEVELOPMENT—**  
BS in Physics, Metallurgy or Electrical Engineering; minimum of 2 yrs. experience in high current silicon rectifier development; must be capable of developing these devices and maintaining technical responsibility through pilot production.

• **PHYSICISTS, CHEMISTS AND METALLURGISTS**  
For semiconductor device development; experience in encapsulation, alloying and diffusion, chemistry of semiconductor devices, materials (to lead a program on metallurgical research of new semiconductor materials).

• **ELECTRONIC ENGINEERS—**  
Experienced in machine controls (relay and/or static) to assist in the development and application of static transistorized controls.

• **TRANSISTOR PROCESS ENGINEERS—**  
EEs, MEs, and IEs to develop and create new processes for manufacturing germanium and silicon semiconductor devices and to develop automatic and semi-automatic fabrication equipment. Experience preferred.

If you're looking for an opportunity to fully exercise your personal competence . . . among men of talent . . . in unmatched facilities, why not make arrangements to talk with our interviewer when he visits your campus. Or, write for additional information: Mr. C. D. Longshore, Supervisor of Salaried Employment:

*An equal opportunity employer*



# THE BELL TELEPHONE COMPANIES

## SALUTE: HAL D'ORAZIO

Hal D'Orazio (B.S.I.E., 1961) was given important engineering responsibilities the moment he reported to Illinois Bell. Hal, as Assistant Engineer, studied conditions affecting a vital submarine transmission cable crossing in Chicago. His recommendations were well received by his management, particularly since they contained some unique cost-saving ideas on tunneling methods.

Hal's initial success has earned him other difficult assignments involved with transmission systems. More opportunities for Hal to show what he can do!

Hal D'Orazio and other young engineers like him in Bell Telephone Companies throughout the country help bring the finest communications service in the world to the homes and businesses of a growing America.



### BELL TELEPHONE COMPANIES

TELEPHONE MAN-OF-THE MONTH



# Glass Stronger Than Steel

By Vic Bell, Eng. Phy. '66

There are more demanding applications for fiberglass than its use in sports car bodies. Fiberglass wound on a mandril, much like the rubber band around the core of a golf ball, and coated with resin during the winding is being used experimentally as motor casings for Polaris missiles.

Under a Naval research grant, the Theoretical & Applied Mechanics Department of the College of Engineering is exploring the casual factors decreasing the effective strength of glass fibers. The search for a strength density ratio of 1:10<sup>6</sup> (in., 0.4:10<sup>6</sup> greater than that of steel, necessitates statistical studies of the effects of moisture, annealing, and mechanical damage. Results of experiments by R. A. Wallhaus indicating a significant decrease in fiber strength caused by moisture attacking the glass surface have led Owen-Corning and Johns-Manville, suppliers of the type E boro-silicate glass, to

apply a thin plastic coating to the fibers as they are being drawn from the die. The plastic serves a dual purpose in that it also provides a stronger glass-resin bond in the finished motor case.

Resin properties, while not contributing materially to the strength of individual fibers, are of considerable importance in determining the maximum bursting pressure of the motor case. Greater flexibility and adhesiveness of the resin tends to increase bursting pressures. Research in this field continues on the manner in which cracks spread through a specimen causing failure.

There are good indications that a cross section strength exceeding 100,000 psi will be developed in the near future and that this figure will double in five years. The Theoretical & Applied Mechanics Department is helping to attain this goal. ♦♦♦

---

---

## *Plan to Attend*

# ENGINEERING OPEN HOUSE

## MAY 10 and 11

Whether you are a college or high school student you have undoubtedly heard of the Illinois Junior Academy of Science, the Junior Engineering Technical Society, or Engineering Open House. In the past, each of these groups has sponsored an exposition on the University of Illinois campus. This year, in an attempt to co-ordinate the efforts of the various groups and reduce the number of trips that high school students make to such meetings, all three expositions will be held on the same dates, Engineering and Science Weekend, at the University of Illinois, May 10 and 11.

The Illinois Junior Academy of Science will hold their meeting in the new Assembly Hall south of the stadium. This will be the first exhibit of any type in the new hall, it is anticipated that it will be the biggest year IJAS has ever had. The area about the hall will be the parking area for all the events

—buses will run a shuttle service from the hall to all points on campus.

The Junior Engineering Technical Society will hold their meeting in the Illini Union as they did last year. However, they should be able to expand their activities considerably as the new addition to the Union will be in operation at that time.

The College of Veterinary Medicine has usually held an Open House in conjunction with IJAS. This year they plan to have a larger operation and to cooperate with the other groups in arranging tours. They will be located in the Veterinary Medicine Building and the Large and Small Animal Clinic.

In the past, Engineering Open House has been held near St. Patrick's Day in March, but this year it will be held in conjunction with the other groups on May 10 and 11. The headquarters will be at the main desk of the Illini Union

—tour guides will be available there for people who are interested in seeing the campus as part of a group. An effort is being made to include as many students as possible from the freshman and sophomore classes so that this year's Open House can be the best ever. The central theme and purpose of Open House will be guidance in selecting the right career field, with special help to students interested in physical science and engineering. Tours offered in the biological, medical, and other science will supplement the engineering efforts.

Articles explaining the exact timetable, arrangements for housing, and special program features will appear in subsequent issues of *Technograph*.

For further information, write  
Walter Hadcock  
475 Garner MRH  
Champaign, Illinois



## Bonnie Lee Mitchell



It's a long way from Baltimore, Maryland, but TECH is glad that Bonnie Lee Mitchell, a freshman math major, made the trip. If you could swim, ski, skate or dance the distance, Bonnie would have enjoyed it since those are her hobbies. Miss Mitchell is already making her mark in the midwest by participating in the Dolphin Show, Nite Lites-Playboy Panacea, and Campus Chest. She also graces the roles of Gamma Phi Beta sorority.

IS YOUR  
FUTURE  
WORTH A  
20 MINUTE  
INTERVIEW?



If you are about to decide on your future employment and are graduating with outstanding scholastic achievement in engineering or the physical sciences . . . the Sandia Corporation would like to arrange an interview with you.

At Sandia, you would work in research, design and development, or engineering. Our scientists and engineers are engaged in projects in the fields of solid state physics, plasma physics, materials research, explosives technology, pulse phenomena and radiation damage.

You would work in a modern well-equipped \$120 million laboratory and be associated with some of this

nation's outstanding technical personnel. You would receive liberal benefits which, in addition to insurance, retirement and vacation, include an opportunity for continuing your graduate studies.

You would be employed in sunny, dry Albuquerque, a Southwestern cultural center of over 250,000, or in our laboratory at Livermore, California, with all the advantages of the San Francisco Bay area.

**Electrical and Mechanical Engineers**  
at all Degree Levels

At MS and PhD Levels  
**Aeronautical Engineers**  
**Ceramic Engineers**  
**Chemical Engineers**

**Industrial Engineers**  
**Chemists**  
**Mathematicians**  
**Physical Metallurgists**  
**Physicists**  
**Engineering Physicists**  
**Statisticians**

Sandia Corporation recruiters will be on your campus soon.\* For appointment for interview, see your College Placement Officer now.

Equal Opportunity Employer

**SANDIA**  
CORPORATION



ALBUQUERQUE, NEW MEXICO  
LIVERMORE, CALIFORNIA

\*The Sandia representative will be on campus February 18,19.



# CHALLENGE IN CALIFORNIA

## IN ALL PHASES OF CIVIL ENGINEERING

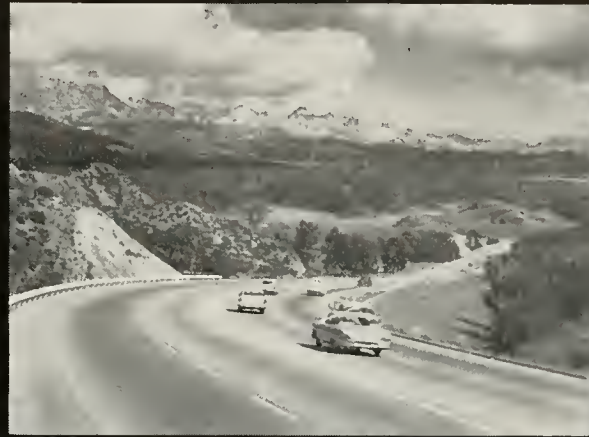

**HIGHWAYS  
BRIDGES  
STRUCTURAL  
SANITARY  
HYDRAULIC**



California's far-flung state engineering projects are no boom-time enterprises. They are sustained, long-range operations planned to keep pace with the continued growth of the state. They offer employment stability, good salaries, job rotation and professional advancement. May we send you details and campus interview schedule of our representatives? When writing, please tell us your field of interest. State Personnel Board, 801 Capitol Avenue, Sacramento, California.

# CRYOBIOLOGY

## *Medical Advances Through Engineering*

by  
WAYNE  
CROUCH

The preservation of biological materials for months, years, and perhaps centuries is no longer just fanciful thinking. Much research is presently being done on the effects of extreme cold on biological materials. And, although this research is only in its infancy, many applications have been found for the experimental findings. For example, in the cattle-breeding industry the freeze-preservation of bull semen is already a well-established commercial process. Methods which have been developed for freezing whole blood are also being evaluated clinically with marked success. In addition, initial successes in the freezing of microorganisms, bone marrow, tissues, and even whole organisms for extended periods of time have excited the imagination of clinicians and researchers in the natural sciences. As one can easily see, the neoteric science of cryobiology promises to be one of the most significant and rewarding sciences in the years to come.

The undisputed pioneer in cryobiological research is Father B. J. Luyet, a biophysicist. From his probing into the basic question, "What is Life," arose the initial concepts of cryobiology. Luyet questioned how cold alone without structural disturbance could kill, since cold is merely a lowering of the velocity of molecular motion.

The investigations of Luyet began approximately 25 years ago. And soon other independent investigators, recognizing the significance of his findings, undertook studies to demonstrate the feasibility of ultra-low temperature preservation as well as to determine the cause of damage to specimens during freezing. Just recently, Dr. Audrey Smith opened the area of applied cryobiology by successfully freezing hamsters for short periods of time.

From the innovations of these indi-

vidual researchers an integrated group of biologists, biochemists, biophysicists and engineers of Linde Company, a division of Union Carbide Corporation, was organized to study the basic phenomena in cryobiology and to devise practical processes for the freezing and storing of all types of biological specimens. A portion of the findings of this group and of other researchers is explained below.

### Whole Blood

Initially the scientists concentrated their efforts on making the long-term preservation of whole blood practical. As would be expected, this effort received the support of many medical institutions, and in particular the group received the direct support of the Office of Naval Research. Under present blood banking techniques, whole blood can be stored for only 21 days. After this time, the damage which occurs to a number of red blood cells results in their rapid excretion after transfusion. The researchers hoped to find a longer lasting method of preservation in freezing. To date their goal has at least been partially accomplished. They found that by combining the blood with a chemical additive (the most successful being a plasma substitute — polyvinylpyrrolidone, PVP) freezing and thawing could be accomplished with less cell damage. The remaining problem is that of perfecting the additive so that the blood can be transfused without removing it.

According to the new process, the blood must be lowered to the temperature of liquid nitrogen ( $-196^{\circ}\text{C.}$ ) in less than one minute. This is no great problem, but to facilitate heat transfer the blood is frozen in specially coated aluminum containers. When needed, the frozen blood can be thawed in less than one minute by agitating the aluminum containers in warm water.



Of the blood freeze-preserved to date, experimenters at the University of Buffalo Medical School have successfully transfused one-half pint quantities under experimental conditions. Of the cells intact at the time of transfusion, approximately 75% were found to survive in circulation 24 hours later. These results compared favorably with blood banked by normal procedures for two to three weeks and lead researchers to believe that future improvements will yield a frozen blood product comparable to fresh blood upon transfusion.

#### Bone Marrow

In the past few years blood transfusion has been developed to a great degree. However, much research has also been conducted on the transfusion of bone marrow—the blood cell producer. When bone marrow is destroyed by irradiation (or chemotherapy) it no longer produces the required blood cells and anemic deficiencies develop. At present there are no reliable methods for replacing the destroyed bone marrow; however, recent progress indicates that successful transfusions in human patients will soon become a practical reality. The next problem, then, is a means of preservation.

A practical system for preserving bone

marrow cells indefinitely by freezing has recently been developed according to Dr. A. W. Towe of Linde Company. One of the most important steps in the procedure is to effect the phase transition from water to ice as rapidly as possible. When this is done, a suitable viability can be demonstrated by metabolic assay methods. The outstanding problem remaining seems to be the immunological compatibility of the bone marrow. However, this problem is being worked on extensively in both the United States and Canada in hopes that transfusions of bone marrow will soon be as safe and useful as those of blood.

#### Cells and Tissues

From the blood and bone marrow research programs, the low-temperature preservation studies have been expanded into other areas, and techniques for preserving a number of animal tissues and cells for prolonged durations have been developed. Although the specific method of freezing and storing which will insure maximum recovery of viable tissues and cells depends upon the particular type of cell and tissue culture, in general, the best results have been obtained by cooling at a precisely controlled rate, using a proper amount of a protective additive, and storing at liquid

nitrogen temperature.

Although the preservation of blood has a more popular appeal, tissue and cell preservation has an equally important influence in research. These cold storage methods are leading to the establishment of tumor and tissue banks, particularly in the cancer field, that make it possible for researchers to work with the original specimen whenever needed. In addition, use of liquid nitrogen and advanced liquefied transport containers will permit the same material to be distributed to investigators in different locations and enable them to run comparative experiments.

#### Expanding Field

Numerous other areas are continually revealing themselves for the applications of low temperature studies. In addition to the successful preservation of bull semen, studies are presently being aimed at extending this process to other species, such as swine, sheep, and turkeys. On the mechanical side, cryobiological applications also depend on the development of better liquid nitrogen equipment, refrigerators to store specimens indefinitely, freezers to control the rate of cooling precisely, and low-loss liquefied gas containers to transport liquid nitrogen economically. ◆◆◆

---

---

## St. Pat's Ball

# THE ENGINEERING KNIGHT'S NIGHT

This year's St. Pat's Ball will carry on many of the fine traditions of the past but differ from the past balls in several aspects. Dean Everitt will again crown the Queen of the ball, and St. Pat, Prof. Dale Greffe, will initiate the knights of St. Pat. Scene of this year's ball will be the Illini Room, the great ballroom of the new Illini Union addition. Musical entertainment for the evening will be provided by nationally renowned Skitch Henderson and his band.

St. Pat's Ball will be one of the first, if not the first, dance to be held in the new ballroom. The Illini Room, which will hold 1300 couples, has about twice the capacity of present Union facilities and almost the same capacity as Huff Gym. With the other services of the Union available, such as checkrooms, refreshment, and lounges for comfortable sit-down relaxation, a dance in the new and beautiful Illini Room promises to be a memorable evening.

Last year the St. Pat's Ball committee

started a policy of hiring name bands to provide top-notch entertainment for the evening. This year's committee in accordance with this policy obtained the services of Skitch Henderson and his band. Skitch is now musical director for the National Broadcasting Company and appears nightly with his band on the "Tonight" show. Mr. Henderson is an accomplished pianist and conductor. An evening with Skitch Henderson promises to provide the best dance music this campus has heard in a long time.

The Knights of St. Pat represent an honorary organization of outstanding engineering students and faculty members at the University of Illinois. Candidates are selected on the basis of service to their own society, service to the College of Engineering, and success in a supportive personal interview. Each society and major organization in the college can nominate candidates. The choice is made by a board composed of three engineering faculty members and two past Knights. Knightship in the

Knight's of St. Pat is the highest honor offered by the College of Engineering.

The crowning of the queen is one of the high points of the evening. Each engineering society is allowed to sponsor one candidate, and the queen is chosen by popular election at the ball.

St. Pat's Ball is sponsored by the Engineering Council and in the past has been held the same weekend as Engineering Open House. Due to the late date of Open House this year, however, the two events are not being held together. The ball will be presented on the evening of Saturday, Mar. 16, from 9 p.m. to 1 a.m. There will be a pre-sale of tickets to engineers during registration week, Monday, February 4 through Thursday, February 7. The ticket booth will be conveniently located just outside the Engineering Library in Civil Engineering Hall. All engineers are advised to buy their tickets at this time. If they wait until the regular sale, they may be among the unfortunate victims of a sell-out.

# LACK of CULTURE

by Benny Babb BSGE '62

**This new and encouraging inspection of the engineer and 'culture' won first place in the national semi-annual Tau Beta Pi pledge essay contest. Competition was among one hundred chapter winners. Benny received his B.S. in General Engineering in August and now works for the Linde Company, a division of Union Carbide, in East Chicago, Indiana.**

Since the verbal duel between Thomas Henry Huxley and Matthew Arnold in the early 1880's, there have been repeated flare-ups of the science versus culture battle. Some of the early issues, such as the necessity for mastery of Greek and Latin, are no longer of primary concern. Only the best educated leaders in government or business can distinguish the dative from the genitive or, indeed, recall who was teacher and who was pupil: Plato or Socrates. However dead the original issues of natural science opposed to classical education appear to be, the basic charge of a narrow and materialistic discipline is still leveled at our engineering and technical schools today.

The too frequent defense to this charge is the plea of lack of time. The number of hours required for mastery of any technical field has steadily increased in recent years. Programs which could be easily finished in four years now require an extra semester or more. Rapid scientific progress, such as that initiated by the splitting of the atom, has increased the basic areas of scientific knowledge that should be a part of every engineer's training. For example, quantum mechanics is opening doors in almost all specialized engineering fields from metallurgy to electronics. Without the tools of basic chemistry and physics, an engineer becomes merely a handbook technician. Truly, there is not even time to learn the basic sciences, let alone investigate philosophy and the humanities.

Another quick but shallow defense is found by belittling the importance of the classics. This line of denial is hardly worth noting since scientific educators themselves will not give it credence. The insights of Dante or the wisdom

of Spinoza cannot be easily brushed aside.

Culture should be and generally is postulated as one of the prime requirements of an educated man. Certainly, the study of the humanities must be recognized as the most direct route to cultural attainment. Again, if we accept culture as a prerequisite, then lack of time is an unsatisfactory excuse.

The need for cultural awareness in men of science is more apparent now than ever before. Even though somewhat unwillingly, the engineer or scientist is assuming leadership in our world today. He is the doer, the creator and — in time of war — the destroyer. When a new problem arises, science is called on for the answer. Yesterday it was but necessary to build the machine or detail the procedure. Today, the scientist must not only initiate the action towards a solution but must also specify how and when it should be used. As shown by the atomic bomb and automation, the scientist can no longer avoid the consequences of his creations. Just as the deeds of Mr. Hyde come back to Dr. Jekyll, so too must science answer for the results of science. And to the extent that the end results of scientific advancement are far removed from the laboratory, the engineer and scientist must prepare themselves for this new ground. How then, since science and society are now so closely wed can our schools produce both technically competent and culturally balanced men?

Before attempting an answer, the charge itself must be questioned. Do men of science actually lack culture? If we define culture only by the measures of art, music or literature — the all too common goal of the strict classicist —



then perhaps the engineer can be said to have little or no culture. True culture, however, is the improvement, refinement or development of the mind, emotions, manners and judgement. Given these standards from which to judge the attainment of culture, let us examine the engineer and man of science.

First, there can be little argument that the engineer has not developed his mental processes to at least equal or better than the level of the classicist. The very core of the engineering method with analysis and synthesis as principal tools will compare with the best that logic can offer. Induction and deduction are the prime tools of the scientist. And can the philosopher, whose stated task is the search for final truth, even compare his results with those of the scientist whose work is the absolute truth? Can we imagine a modern engineer being led along the path of Hegel or Nietzsche? There is no evidence that men of science were more duped by Hitler than were the academicians. It is sufficient to say only that the very nature of a scientific discipline requires mental development of the highest degree.

Second, let us look at the area of emotional refinement and development. Again, the nature of scientific study demands control of the emotions. The engineer is schooled to report objectively the results of his experiments. Personal theories, wants, and desires must give way to scientifically observed facts. For those who insist that emotion involves appreciation of beauty, ask the scientist where beauty lies. Beauty is in all nature, in form and structure, in the discovery of absolute truth and in creation or invention. All of these are the province of the scientist.

Next, examine manners. Manners refer to the way one lives and acts, not to the subtleties of the proper fork for fish or dress for dinner. While there are certainly individual cases among engineers and scientists of sloppiness or incouthness, there is little quantitative evidence to show that as a group they are lacking in refinement. White tie and tails are not the engineer's customary dress, yet his scientific training again has taught him the value of neatness and attention to detail. At any rate, the Bohemian and the Beatnik are not the product of the scientific training. They paw forth poetry without meaning, art without reason, and curses upon the world that exists — but leave mankind to better for their passage. The scientist

tries, at least, to cure the ills, not just berate them.

Last, in the matter of judgment, we should note that experience and ability to reason are the essentials.

While there can be little question concerning the engineer or scientist's ability to reason, there has been a traditional lack of experience in all but technical matters. To gain judgment through personal experience alone is too costly of time. Apparently, the cry of the classicist for historical study to learn from the experiences of the past must be heeded. But the demonstrated power of the scientifically trained mind to grasp new concepts should dictate the character and duration of such study.

While our inspection has been brief, we should have at least reached the conclusion that we must look further and deeper. Does the engineer truly lack culture? Before lengthening already overlong curricula, the educators of today should examine carefully the true meaning of culture and see if this development is not already a potentially strong part of engineering and scientific training. The development of the reasoning processes by the scientific method of analysis and synthesis provide our engineers with the primary ingredient of basic wisdom.

Some areas of weakness — such as awareness of the social consequences of scientific advancement — could easily become an integral part of each technical course. Just as the demands of business and industry have forced our schools to add economic aspects to purely technological considerations, our educators must now shift emphasis to the social side of science.

To the extent that the engineer is found wanting in cultural judgment, we must give the training necessary. This training, however, should be at a higher level than that now generally used for sociology and the humanities. Given a scientifically trained mind and an awareness of the need for social and esthetic values, the engineer should readily acquire the essential lessons of concentrated study in history.

Above all, we must recognize that the time is past for technical science and social culture as separable entities. The engineers and scientists now training in our universities and colleges will soon be called to act on problems that affect the entire world. Their ability to formulate lasting solutions will depend as much upon their social awareness as upon their technical competence. ♦♦♦

# BIG DECISION

For Engineers  
-To-Be...

SHALL IT BE

#9000 Castell Wood Drawing Pencil or  
#9800SG Locktite Tel-A-Grade Holder and  
#9030 Castell Refill Drawing Leads ?

Perhaps you will choose Castell wood pencil, because you like the feel of wood, because you like to shave the point to the exact length and shape you desire.

Or you may vote for Locktite Tel-A-Grade, the lightweight balanced holder with its long tapered, no-slip serrated grip that soothes tired fingers. And its ideal team mate, Castell Refill leads, of the same grading, undeviating uniformity and bold image density of Castell wood pencil.

Whatever your choice, you will be using Castell tight-textured microlet-milled lead that gives you graphite saturation that soaks into every pore of your drawing surface.

Your College Store carries all three famous A.W.Faber-Castell drawing products, backed by over two centuries of pencil-making experience. Start your career by using the finest working tools money can buy.

**A.W.FABER-CASTELL**

Pencil Company, Inc.  
41-47 Dickerson Street  
Newark 3, N. J.

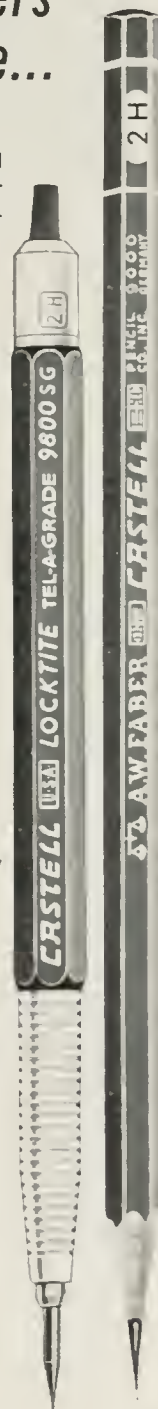

# LACK of CULTURE

by Benny Babb BSGE '62

**This new and encouraging inspection of the engineer and 'culture' won first place in the national semi-annual Tau Beta Pi pledge essay contest. Competition was among one hundred chapter winners. Benny received his B.S. in General Engineering in August and now works for the Linde Company, a division of Union Carbide, in East Chicago, Indiana.**

Since the verbal duel between Thomas Henry Huxley and Matthew Arnold in the early 1880's, there have been repeated flare-ups of the science versus culture battle. Some of the early issues, such as the necessity for mastery of Greek and Latin, are no longer of primary concern. Only the best educated leaders in government or business can distinguish the dative from the genitive or, indeed, recall who was teacher and who was pupil: Plato or Socrates. However dead the original issues of natural science opposed to classical education appear to be, the basic charge of a narrow and materialistic discipline is still leveled at our engineering and technical schools today.

The too frequent defense to this charge is the plea of lack of time. The number of hours required for mastery of any technical field has steadily increased in recent years. Programs which could be easily finished in four years now require an extra semester or more. Rapid scientific progress, such as that initiated by the splitting of the atom, has increased the basic areas of scientific knowledge that should be a part of every engineer's training. For example, quantum mechanics is opening doors in almost all specialized engineering fields from metallurgy to electronics. Without the tools of basic chemistry and physics, an engineer becomes merely a handbook technician. Truly, there is not even time to learn the basic sciences, let alone investigate philosophy and the humanities.

Another quick but shallow defense is found by belittling the importance of the classics. This line of denial is hardly worth noting since scientific educators themselves will not give it credence. The insights of Dante or the wisdom

of Spinoza cannot be easily brushed aside.

Culture should be and generally is postulated as one of the prime requirements of an educated man. Certainly, the study of the humanities must be recognized as the most direct route to cultural attainment. Again, if we accept culture as a prerequisite, then lack of time is an unsatisfactory excuse.

The need for cultural awareness in men of science is more apparent now than ever before. Even though somewhat unwillingly, the engineer or scientist is assuming leadership in our world today. He is the doer, the creator and — in time of war — the destroyer. When a new problem arises, science is called on for the answer. Yesterday it was but necessary to build the machine or detail the procedure. Today, the scientist must not only initiate the action towards a solution but must also specify how and when it should be used. As shown by the atomic bomb and automation, the scientist can no longer avoid the consequences of his creations. Just as the deeds of Mr. Hyde come back to Dr. Jekyll, so too must science answer for the results of science. And to the extent that the end results of scientific advancement are far removed from the laboratory, the engineer and scientist must prepare themselves for this new ground. How then, since science and society are now so closely wed can our schools produce both technically competent and culturally balanced men?

Before attempting an answer, the charge itself must be questioned. Do men of science actually lack culture? If we define culture only by the measures of art, music or literature — the all too common goal of the strict classicist —



hen perhaps the engineer can be said to have little or no culture. True culture, however, is the improvement, refinement or development of the mind, emotions, manners and judgement. Given these standards from which to judge the attainment of culture, let us examine the engineer and man of science.

First, there can be little argument that the engineer has not developed his mental processes to at least equal or better than the level of the classicist. The very core of the engineering method with analysis and synthesis as principal tools will compare with the best that logic can offer. Induction and deduction are the prime tools of the scientist. And can the philosopher, whose stated task is the search for final truth, even compare his results with those of the scientist whose work is the absolute truth? Can we imagine a modern engineer being led along the path of Hegel or Nietzsche? There is no evidence that men of science were more duped by Hitler than were the academicians. It is sufficient to say only that the very nature of a scientific discipline requires mental development of the highest degree.

Second, let us look at the area of emotional refinement and development. Again, the nature of scientific study demands control of the emotions. The engineer is schooled to report objectively the results of his experiments. Personal theories, wants, and desires must give way to scientifically observed facts. For those who insist that emotion involves appreciation of beauty, ask the scientist where beauty lies. Beauty is in all nature, in form and structure, in the discovery of absolute truth and in creation or invention. All of these are the province of the scientist.

Next, examine manners. Manners refer to the way one lives and acts, not to the subtleties of the proper fork for fish or dress for dinner. While there are certainly individual cases among engineers and scientists of sloppiness or uncouthness, there is little quantitative evidence to show that as a group they are lacking in refinement. White tie and tails are not the engineer's customary dress, yet his scientific training again has taught him the value of neatness and attention to detail. At any rate, the Bohemian and the Beatnik are not the product of the scientific training. They spew forth poetry without meaning, art without reason, and curses upon the world that exists — but leave mankind no better for their passage. The scientist

tries, at least, to cure the ills, not just berate them.

Last, in the matter of judgment, we should note that experience and ability to reason are the essentials.

While there can be little question concerning the engineer or scientist's ability to reason, there has been a traditional lack of experience in all but technical matters. To gain judgment through personal experience alone is too costly of time. Apparently, the cry of the classicist for historical study to learn from the experiences of the past must be heeded. But the demonstrated power of the scientifically trained mind to grasp new concepts should dictate the character and duration of such study.

While our inspection has been brief, we should have at least reached the conclusion that we must look further and deeper. Does the engineer truly lack culture? Before lengthening already overlong curricula, the educators of today should examine carefully the true meaning of culture and see if this development is not already a potentially strong part of engineering and scientific training. The development of the reasoning processes by the scientific method of analysis and synthesis provide our engineers with the primary ingredient of basic wisdom.

Some areas of weakness — such as awareness of the social consequences of scientific advancement — could easily become an integral part of each technical course. Just as the demands of business and industry have forced our schools to add economic aspects to purely technological considerations, our educators must now shift emphasis to the social side of science.

To the extent that the engineer is found wanting in cultural judgment, we must give the training necessary. This training, however, should be at a higher level than that now generally used for sociology and the humanities. Given a scientifically trained mind and an awareness of the need for social and esthetic values, the engineer should readily acquire the essential lessons of concentrated study in history.

Above all, we must recognize that the time is past for technical science and social culture as separable entities. The engineers and scientists now training in our universities and colleges will soon be called to act on problems that affect the entire world. Their ability to formulate lasting solutions will depend as much upon their social awareness as upon their technical competence. ♦♦♦

# BIG DECISION

For Engineers  
-To-Be...

## SHALL IT BE

- #9000 Castell Wood Drawing Pencil or
- #9800SG Locktite Tel-A-Grade Holder and
- #9030 Castell Refill Drawing Leads ?

Perhaps you will choose Castell wood pencil, because you like the feel of wood, because you like to shave the point to the exact length and shape you desire.

Or you may vote for Locktite Tel-A-Grade, the lightweight balanced holder with its long tapered, no-slip serrated grip that soothes tired fingers. And its ideal team mate, Castell Refill leads, of the same grading, undeviating uniformity and bold image density of Castell wood pencil.

Whatever your choice, you will be using Castell tight-textured microlet-milled lead that gives you graphite saturation that soaks into every pore of your drawing surface.

Your College Store carries all three famous A.W.Faber-Castell drawing products, backed by over two centuries of pencil-making experience. Start your career by using the finest working tools money can buy.

### A.W.FABER-CASTELL

Pencil Company, Inc.  
41-47 Dickerson Street  
Newark 3, N. J.



"All systems are go . . . reading you loud and clear!"

Reasons for building a career at Collins:

**MERCURY** Every voice from the Mercury capsules has been transmitted to earth by Collins equipment. In fact, every phase of the Mercury voyages — from launch and orbit to re-entry and recovery — required communications supplied by Collins. □ Mercury opened the door to space communications. Just ahead are Projects Gemini and Apollo. And the E.E., M.E., Mathematician, or Physicist who can qualify for Collins' space communications team is set for an adventuresome career. Interested? Get complete details from your Placement Office. Or write the Collins engineering center nearest you.



L. R. Nuss,  
Collins Radio Company,  
Cedar Rapids, Iowa

C. P. Nelson,  
Collins Radio Company,  
Dallas, Texas

E. D. Montano,  
Collins Radio Company,  
Newport Beach, California



# ITT: AN AMERICAN CORPORATION WITH AN INTERNATIONAL VIEWPOINT

Facts bearing on professional careers at ITT  
answering questions frequently asked us by college seniors

## A MAJOR CONTRIBUTOR TO U. S. DEFENSE

The largest American-owned international enterprise engaged in all aspects of electronic and telecommunication systems, International Telephone and Telegraph Corporation operates both domestic and foreign divisions and subsidiaries. Among its nine principal U.S. engineering/scientific organizations, four are engaged in advanced work for the Armed Forces and NASA. Programs include:

large scale computer-based command/control systems □ global communication systems (line of sight, tropo scatter, lunar bounce, digital, telecommunications) □ ICBM base communications and control systems □ satellite control & communication systems □ engineering support for large scale warning systems □ antisubmarine warfare systems □ electronic countermeasures □ tactical military air navigation systems □ ground support & environmental test systems □ infrared detection & guidance systems □ atomic clocks □ systems management: world-wide, local.

## DEEP IN DIVERSIFIED U. S. COMMERCIAL ENTERPRISES

Prominent among ITT's domestic commercial products is a new, high-speed digital communication system for large industrial firms. ITT in the U. S. also develops and manufactures a vast variety of radio equipments and systems, automatic programmers, teleprinters, telephone equipment, infrared image converters, image storage and intensifier tubes, high resolution scanners, twt's, coaxial cables and other products.

Today, no less than 53 plants and facilities are operated by 16 ITT divisions or subsidiaries in the United States. Their combined income amounts to roughly 40% of the total figure for the world-wide operations of the parent corporation, whose re-

sources stand solidly behind each operation, at home and abroad.

## ITT IN RESEARCH & DEVELOPMENT ENGINEERING

Basic and applied investigations relate to both military and commercial programs. Extensive R & D facilities are provided. To cite one example, ITT's own "Space Communications Research Station," erected in Nutley, N. J., was selected by NASA as one of the ground terminals for the Project Relay experimental satellite communication system.

## A PIONEER IN SYSTEMS ENGINEERING

ITT's long experience in the operation of world-wide communication systems has made it a logical choice for both systems development and systems management contracts awarded by the Armed Forces. Examples are:

Systems development, design and management of the vast SAC global command/control system 465-L □ Coordination and management of the 10 year program to expand and modernize AIR COM, global communications system of the U. S. Air Force.

## GLOBAL PRACTITIONER OF FIELD ENGINEERING

In the Arctic, in the Tropics, on land, afloat, or undersea, ITT skills in on-site engineering for every kind of communication or large scale electronic system have been thoroughly tested. It is equipped to provide complete engineering support anywhere in the free world. This includes installation, operation, maintenance, evaluation and continuous modernization, as assignments may require. ITT's responsibilities in field and applications engineering include: operation, maintenance and testing of Pacific Missile Range facilities for the U. S. Navy □ engineering support, installation and maintenance for a global digital command and control

system for SAC □ tropo scatter communication systems spanning nations in Europe and Asia □ 6,000 miles of advanced radar and communications equipment on DEWLINE.

## UNIQUE INTERNATIONAL PROFESSIONAL ENRICHMENT RESOURCES FOR

ITT foreign affiliates and subsidiaries operate public telephone systems in 19 countries. In addition, more than 12 overseas laboratories have made many significant advances in communications technology. Technical papers and progress reports steadily circulate among R & D people both at home and abroad, and leading ITT scientists and engineers participate in international seminars conducted annually by the company.

## OPPORTUNITIES EXIST FOR RECENT GRADUATES AT THE BS, MS and PhD LEVELS WITH 9 U. S. MEMBERS OF THE ITT CORPORATE FAMILY

ITT Components Division, Clifton, N. J. □ ITT Communication Systems Inc., Paramus, N. J. □ ITT Federal Electric Corporation, Paramus, N. J. □ ITT Federal Laboratories, Nutley, N. J. □ ITT Federal Laboratories, Ft. Wayne, Ind. □ ITT Industrial Laboratories Division, Ft. Wayne, Ind. □ ITT Information Systems Division, Paramus, N. J. □ ITT International Electric Corporation, Paramus, N. J. □ ITT Kellogg Communications Systems Division, Chicago, Ill.

For detailed information about specific positions in your special field of interest, make an appointment through your College Placement Director for an On-Campus Interview or write directly to: Mr. W. A. Moorhead, Mgr., Recruitment and Placement, North America, International Telephone and Telegraph Corporation, 320 Park Avenue, New York 22, N. Y. An Equal Opportunity Employer

# ITT

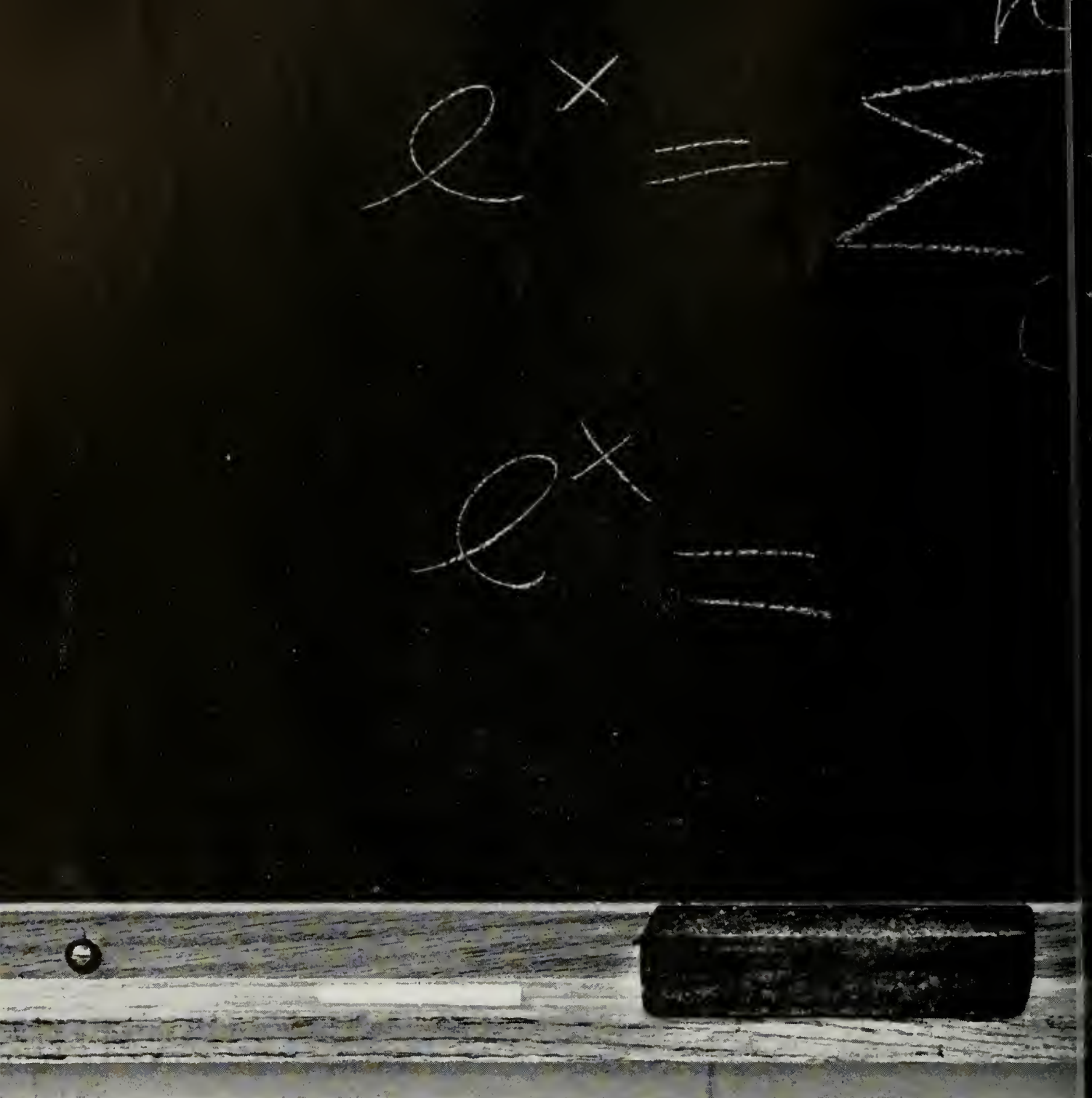

At **IBM** a new world of opportunity in data processing

In the world of data processing many new ideas start an expanding progression of new technologies, new systems, and new applications. This evolution runs full circle in that it forms the stimulus for even further data processing creativity. Within this expanding world, people at IBM are building careers by meeting challenges with imagination through their knowledge of science, engineering, business, and the arts. Through this progression their achievements in turn become the source of new concepts in tomorrow's information systems for business, industry, science, education, and government.

The rapid growth and development of the data processing field thus present exceptional career opportunities and the professional stimulus that provide for individual accomplishment. There is a wide choice of engrossing assignments which can introduce you to satisfying and rewarding careers: working in the basic sciences to explore new technologies, methods, and materials; designing data processing equipment and planning manufacture; evaluating performance of new systems during development and manufacture; studying new applications for machines and systems.



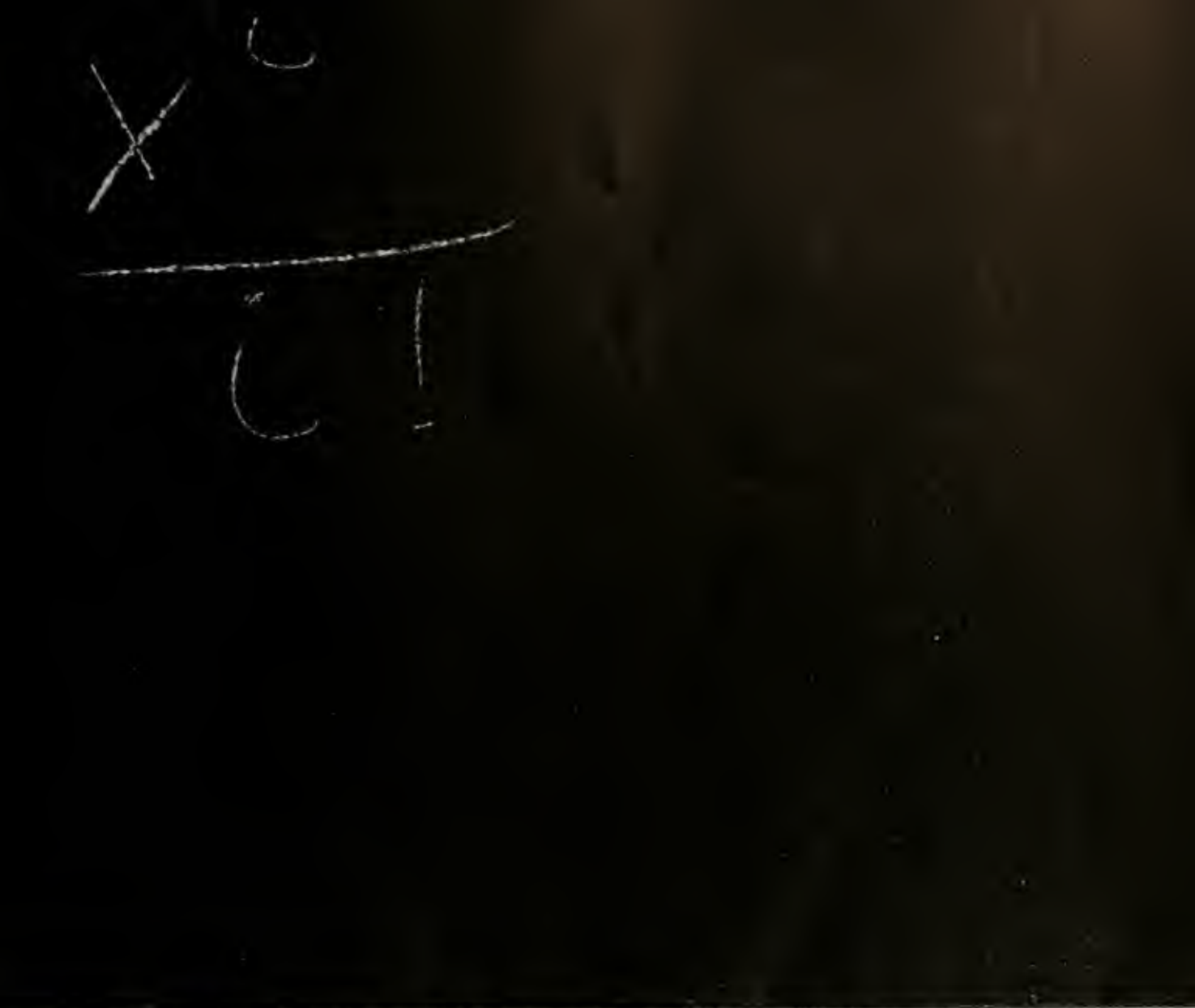

Data processing at IBM has created many new growth positions for career-minded graduates—from research, engineering, and development to manufacturing . . . .

Development Engineering: Bachelor of Science or advanced degree in electrical or mechanical engineering, mathematics, or physics.

Manufacturing Engineering: B.S. or advanced degree in industrial, electrical, or mechanical engineering.

Programming: Bachelor's or Master's degree, preferably in mathematics, the sciences, engineering, or business administration.

IBM education programs provide opportunities to keep employees abreast of expanding technologies and help them branch out into the new areas of discovery. Specific IBM educational programs offer company training courses; tuition-refund courses at universities and colleges nearby; and fully paid, competitive scholarships for full-time study at a university of the employee's choice. IBM advantages include a complete range of company-paid benefits. IBM is an Equal Opportunity Employer. For further details on specific career opportunities, write Manager of Employment, 590 Madison Ave., Dept. 915, N.Y. 22, N.Y.

# NASA...your place in space

## NASA programs encourage swift professional growth for the engineer or scientist launching his career

You can accelerate your career swiftly as a professional staff member of the National Aeronautics and Space Administration. Stimulating assignments, unequaled resources, liberal programs of educational assistance, early responsibility—all help hasten the professional growth of the engineer or scientist who chooses NASA for his initial career position.

Each NASA research center offers its own comprehensive plan to help advance your knowledge and speed the time when you can contribute at the peak of your capacity. The plans differ from center to center, but this summary is generally valid throughout the NASA complex:

### NASA Installations Maintain University Ties

NASA centers have established close relationships with nearby universities. As a professional staff member, you may pursue graduate study either in the evening at NASA's expense or during regular working hours on full salary. And, if necessary to fulfill university requirements for a graduate degree, you may become a resident student, also on full salary.



NASA encourages advanced study in astronautics, physics, electronics, chemistry, metallurgy, mathematics, astronomy, and geophysics, as well as aeronautical, mechanical, electronic, electrical, nuclear, ceramic, and civil engineering, engineering mechanics, and engineering physics.

### Guggenheim, Sloan, Brookings Fellowships Available

Additional avenues of opportunity will be open to you because NASA participates



in fellowship programs of the Guggenheim and Sloan Foundations and the Brookings Institution. Right now, as a result of this participation, NASA staff members are attending Cal Tech, M.I.T., Harvard, and other leading schools, receiving full salary, expenses, and per diem.

NASA helps you keep abreast of the latest developments in your field by permitting frequent attendance at major technical conferences in this country and abroad.

### Unique Intern Programs Increase Technical Competence

The NASA centers offer exhaustive in-house educational opportunities as well, including the unique Intern Programs. The regular in-house activities include lectures, seminars, films, and expense-paid trips to other organizations. The Intern

Program is somewhat different. As an Intern, you study and work closely with a senior NASA scientist or engineer, a leader in his—and your—field. This is an informal and exceedingly productive arrangement, which usually lasts for six months. The Intern Program is designed to bring you very rapidly to the forefront in a special technical area.

### Get All the Facts About a NASA Career

Learn more about your future with NASA. Contact your College Placement Officer to arrange an interview with NASA representatives visiting your school. Or send a letter outlining your interests and background to the Personnel Officer at any one of the following NASA locations: NASA Goddard Space Flight Center, Greenbelt, Md.; NASA Langley Research Center, Hampton, Va.; NASA Lewis Research Center, Cleveland, Ohio; NASA Marshall Space Flight Center, Huntsville, Ala.; NASA Ames Research Center, Mountain View, Calif.; NASA Flight Research Center, Edwards, Calif.; NASA Manned Spacecraft Center, Houston, Texas; NASA Launch Operations Center, Cocoa Beach, Fla.

NASA is an equal opportunity employer. Positions are filled in accordance with Aerospace Technology Announcement 252-B.







## **FORGED...** *to eliminate tool damage and leakers*

The forged steel cylinder cap shown at top is used on the rod end of a Nike missile launcher cylinder.

Before the changeover to forgings, cylinder caps were a source of problems. Tool breakage and tool wear were excessive because the cored castings lacked concentricity, were contaminated with non-metallic inclusions. When the caps, after costly machining, were hydrostatically tested at 4,500 psi, porosity of the castings often resulted in leakers.

***The switch to forgings produced these cost-cutting results:***

***40% reduction in initial cost when forgings replaced castings.***

***20% increase in tool life.***

***12% increase in production — unscheduled tool replacement eliminated.***

***6% rejection rate caused by porosity reduced to zero.***

***10% reduction in weight with increased strength.***

As you take your place in today's high-speed world, where progress is paced by imaginative engineering, it will pay you to ask, "What about forgings?" for many of the things you will develop, design, engineer, produce. Forgings are competitive in price, superior in quality wherever strength/weight ratio, or integrity of material is important.

Write today for case histories on parts made better at lower cost by forging. Address: Drop Forging Association, Dept. E-3, 55 Public Square, Cleveland 13, Ohio.

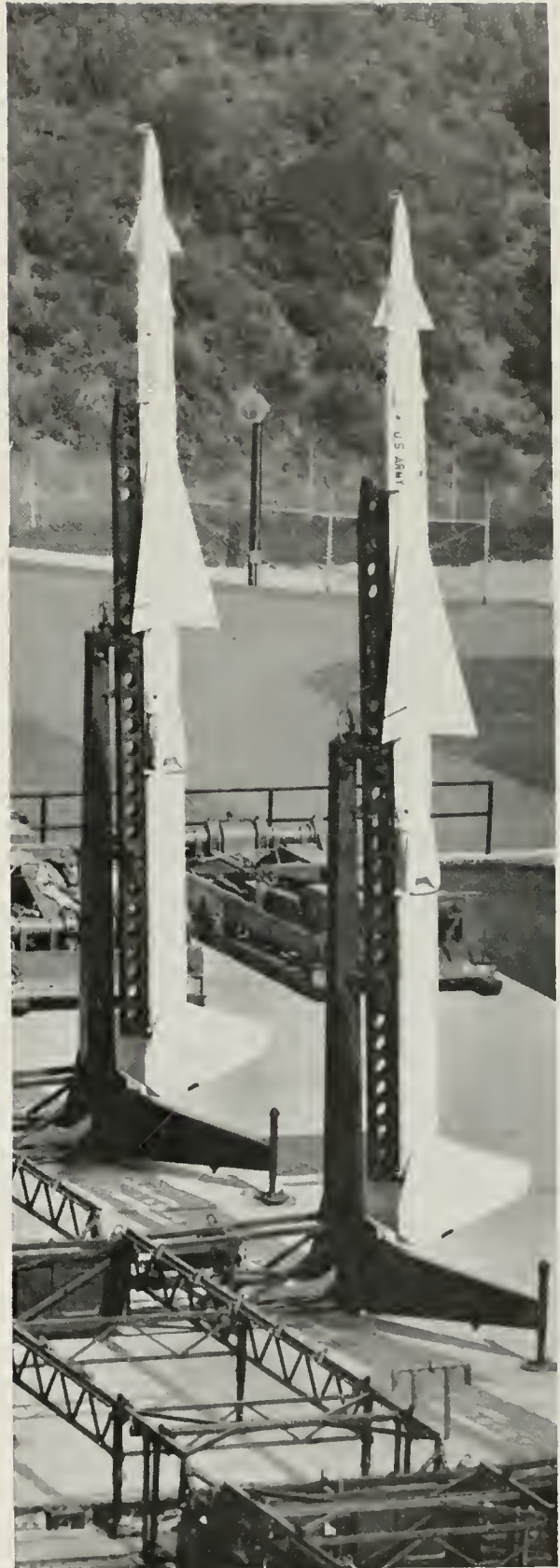

*When it's a vital part, design it to be*

**FORGED**

For more information, see our 4-page, full color advertisements in these magazines: MACHINE DESIGN, DESIGN NEWS, STEEL, MATERIALS IN DESIGN ENGINEERING and AUTOMOTIVE INDUSTRIES.

# ENGINEERING CALENDAR

4- 7	Registration		
8	Classes Begin	7:00 a.m.	
11	"Wave Propagation on Helices" Mr. Paul Klock	4:00 p.m.	141 EEB
12	<b>ASCE</b>	7:30 p.m.	116 E. Chem
	<b>ACS</b>	7:30 p.m.	314B Illini Union
13	<b>SAE</b>	to be announced	
	<b>SWE</b>	7:00 p.m.	141 EEB
18	"A Millimeter Antenna Excited from a Goubau-Beam-Waveguide" Prof. Edward Mast	4:00 p.m.	141 EEB
20	<b>ASME</b>	7:00 p.m.	to be announced
25	Antenna Laboratory Seminar—to be announced Mr. Fred Ore	4:00 p.m.	141 EEB
27	<b>AIIE</b>	7:00 p.m.	253 MEB

## A CAREER . . . *in the* ATOMIC ENERGY COMMISSION

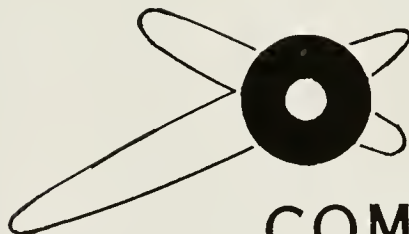

The Atomic Energy Commission offers men and women with B.S. or M.S. degrees in nearly all scientific and engineering disciplines outstanding training programs designed to encourage professional development and to meet individual career objectives.

### ATOMIC INTERNSHIPS 1963 - 1964

- MANAGEMENT
- TECHNICAL
- HEALTH PHYSICS
- NUCLEAR  
ENGINEERING
- CONSTRUCTION  
ENGINEERING
- ATTORNEY
- PATENT ATTORNEY

*All qualified applicants are considered for employment without regard to race, creed, sex, color, or national origin.*

■ WE INVITE YOU TO TALK WITH AN AEC REPRESENTATIVE WHEN HE VISITS YOUR CAMPUS

*For complete information on AEC Training Programs—consult the brochure "A Career in the Atomic Energy Commission" at your placement office or*

*write to . . .*

DIRECTOR OF PERSONNEL  
USAEC—9800 S. Cass Ave.  
ARGONNE, ILLINOIS



# Technoquips

Two engineers had been drinking when one lost his grip on the bar and fell flat on his face on the floor.

"That's what I like about Johnson. He always knows when to quit."

\* \* \*

"Sheldon, why did you kick your little sister in the stomach?"

"Couldn't help it. She turned around too quick."

\* \* \*

Soon after Janice and Montie were married, Janice decided to cook her first chicken. When Montie started to carve it, he said, "What did you stuff it with, dear?"

"It didn't need stuffing, darling," she replied. "It wasn't hollow."

\* \* \*

He smiled at her across the candlelit table. She affectionately smiled in return.

"Smile like that again," he whispered.

She blushed and again cutely displayed her dimples.

"Just as I thought," he said. "You look like a chipmunk."

\* \* \*

A college graduate on his first job was handed a broom to sweep the floors for his first duty.

Grad: "But I'm a college graduate."

Employer: "Oh, in that case, I'll show you how."

\* \* \*

"I'm afraid I can't help you," he said to the man injured in a car accident. "I'm a veterinarian, not a medical doctor."

"You're just the man," moaned the victim. "I was a jackass to think I could do 70 on those old tires."

\* \* \*

"Mr. Jones, I'm afraid your son is spoiled."

"He is not, Mr. Smith, and I resent your saying such a thing."

"Well, have it your own way, but come and see what the steam roller did to him."

\* \* \*

Salesman: "I've been trying for a week to see you. When may I have an appointment?"

Purchasing Agent: "Make a date with my secretary."

Salesman: "Oh, I did, sir—and we had a wonderful time—but I still want to see you."

"What are you putting in your vest pocket there, Murphy?"

"That's a stick of dynamite. Every time Riley sees me he slaps me on the chest and breaks all my cigars. The next time he does it, he's going to blow his hand off."

\* \* \*

Two morons each had a horse, but they couldn't decide which belonged to whom. So they cut the mane off one to differentiate, but it soon grew back. Next they cut the tail off one, but that also grew back. Finally they measured them and found that the black one was four inches taller than the white one.

\* \* \*

College: A fountain of knowledge where students gather to drink.

\* \* \*

"Of course you are the first girl I ever kissed," said the M.E. as he shifted gears with his foot.

\* \* \*

Counselor: "How do you like this room as a whole?"

Freshman: "As a hole it is fine, as a room, not so good."

\* \* \*

Recent tests in the physics department prove that grasshoppers hear through their legs. When a tuning fork was placed near a grasshopper, it was found that in all cases the insect would hop. There was no reaction to this stimulus, however, when the insect's legs were removed.

\* \* \*

"Look at the way these young people dress today!" snorted the judge at the horse show to another judge standing next to him. "See that thing with a poodle haircut, blue jeans, and shirt hanging out. I can't even tell whether it's a boy or girl."

The judge he was talking to coldly answered, "I can assure you it is a girl—she is my daughter."

"My apologies," mumbled the first judge. "I had no idea you were her father."

"I'm NOT," snapped the parent. "I am her mother."

\* \* \*

Husband: "I bought something today for the one I love best. Guess what?"

Wife: "A box of cigars."

Policeman (to intoxicated man who is trying to fit his key into a lamp post): "I'm afraid there is nobody home."

"Mus' be. There's a light upstairs."

\* \* \*

Perfume salesgirl, showing newest brand to customer: "To tell you the truth, I consider this brand unsportsmanlike—sort of like dynamiting fish."

\* \* \*

First drunk: "Shay, you don't open the door with that; it's a cigar butt."

Second drunk: "Good heavens, I smoked my key!"

\* \* \*

It was the sleepy time of the afternoon. The prof droned on and on; formulae, constants and figures. An engineer, sitting in the second row, was unable to restrain himself and gave a tremendous yawn. Unfortunately, as he stretched out his arms he caught his neighbor squarely under the chin, knocking him to the floor. Worried, he bent over the prostrate form just in time to hear a murmur, "Hit me again, Sam. I can still hear him."

\* \* \*

Adapting the name of a celebrated Manhattan eating place, The Forum of the Twelve Caesars, Rome is about to launch a new restaurant called The Forum of the Twelve Kennedys.

\* \* \*

While traveling through the jungle, a missionary met a lion. Seeing that his plight was hopeless, he fell to his knees in anxious prayer.

A few moments later he was greatly comforted to see the lion on its knees beside him.

"Dear Brother," said the relieved missionary, "how delightful it is to join you in prayer when a moment ago I feared for my life."

"Don't interrupt," said the lion, "I'm saying grace."

\* \* \*

On a jammed Boston streetcar, a man stood beside a woman having difficulty keeping her balance in the swaying crowd. Before them sat a husky youth, oblivious to her plight. Eyeing him with mounting indignation, the man finally said, "I'll give you a quarter for that seat." When the boy promptly accepted the coin, the man indicated that the woman was to take the seat. "Oh, no," replied the woman, you take it." "Madam, I don't want to sit down. I merely wish to give this boy a lesson in manners." Then she beamed and settled back contentedly, saying, "Benny, thank the man for his quarter." "I already did, Ma," came the reply.

\* \* \*

"Number, hell," yelled the drunk into the pay phone, "I want my peanuts."

# *Assignment: find a filter paper that works harder the dirtier it gets*



*In chain-drag test, truck raises heavy dust clouds to check air filter efficiency.*

## **Results: Up to 30,000 miles between filter changes in Ford-built cars for '63!**

The 1963 Ford-built cars you see on the road these days can eat dust and keep coming back for more, thanks to improved carburetor air filters.

In our continuing quest to build total quality and service-saving features into Ford-built cars, our engineering research staff explored the entire field of physical chemistry for new air-purifying properties in materials.

The result: a filtering material made of chemically treated wood pulp and paper that permits Ford-built cars under normal operation to go from 24,000 to 30,000 miles before carburetor air filter replacement is required.

The new, tougher filter paper is accordion folded to increase surface area four-fold, permitting higher filtration in a smaller package. The more matter it accumulates, the better it filters right up to its full rated service life. It saves owners time and money. It keeps Ford-built engines livelier longer.

Another assignment completed—and another example of how Ford Motor Company provides engineering leadership for the American Road.



**MOTOR COMPANY**

The American Road, Dearborn, Michigan

**PRODUCTS FOR THE AMERICAN ROAD • THE HOME  
THE FARM • INDUSTRY • AND THE AGE OF SPACE**





Kodak beyond the snapshot

**We make machines**, but Wall Street calls us a chemical company.

People who know nothing about Wall Street associate us with simple little cameras.

Photography involves cameras, and it also involves chemicals. A great deal of our chemical activity, however, does not involve photography. On the other hand, the chemistry of photography now hides inside machines like the ones above, so that photography doesn't seem to involve chemistry any more. "Involved" is certainly the word for the situation.

It is an involved situation but it is also a very healthy one.

So healthy is the demand for electromechanical machines of all kinds and sizes to perform the chemical operations of photography that our sizable body of electromechanical engineers keeps very pleasantly occupied. Possibly you will write to us, and possibly we shall strike up a correspondence, and possibly you too will come to work for us as an electromechanical engineer, and possibly you will be running a vitamin factory for us on the day we pin the 25-year medal on you. That's the beauty of diversification.

**EASTMAN KODAK COMPANY, Rochester 4, N.Y.**

# Manufacturing Careers Offer Diversity, Challenge and Opportunity

## An Interview with G.E.'s H. B. Miller, Vice President, Manufacturing Services



Halbert B. Miller has managerial responsibility for General Electric's Manufacturing Services. This responsibility includes performing services work for the Company in the areas of manufacturing engineering; manufacturing operations and organization; quality control; personnel development; education, training and communications; materials management; purchasing and systems as well as the Real Estate and Construction Operation. Mr. Miller holds a degree in mechanical engineering and began his General Electric career as a student engineer on the Company's Test Course

For complete information about General Electric's Manufacturing Training Program and for a copy of G.E.'s Annual Report, write to: Personalized Career Planning, General Electric Company, Section 699-06, Schenectady 5, New York.

### **Q. Mr. Miller, what do engineers do in manufacturing?**

A. Engineers design, build, equip, and operate our General Electric plants throughout the world. In General Electric, this is manufacturing work, and it sub-divides into categories, such as quality control engineering, materials management, shop management, manufacturing engineering, and plant engineering. All of these jobs require technical men for many reasons. First, the complexity of our products is on the increase. Today's devices—involving mechanical, electrical, hydraulic, electronic, chemical, and even atomic components—call for a high degree of technical knowhow. Then there's the progressive trend toward mechanization and automation that demands engineering skills. And finally, the rapid development of new tools and techniques has opened new doors of technical opportunity—electronic data processing, computers, numerically programmed machine tools, automatic processing, feedback control, and a host of others. In short, the requirements of complex products of more exacting quality, of advanced processes and techniques of manufacture, and of industry's need for higher productivity add up to an opportunity and a challenge in which the role of engineers is vital.

### **Q. How do opportunities for technical graduates in manufacturing stack up with other areas?**

A. Manufacturing holds great promise for the creative technical man with leadership ability. Over 60 percent of the 250,000 men and women in General Electric are in manufacturing. You, as an engineer, will become part of the small technical core that leads this large force, and your opportunity for growth, therefore, is unexcelled. Technical graduates in manufacturing are teamed with those in marketing who assess customer needs; those in research and development who conceive new products; and those in engineering who create new product designs. I sincerely believe that the role of technical graduates of high competence in the manufacturing function is one of the major opportunities for progress in industry.

### **Q. What technical disciplines are best suited to a career in manufacturing?**

A. We need men with Doctor's, Master's, and Bachelor's degrees in *all* the technical disciplines, including engineering, mathematics, chemistry and physics. We need M.B.A.'s also. General Electric's broad diversification plus the demands of modern manufacturing call for a wide range of first-class technical talent. For one example: outside of the Federal Government, we're the largest user of computers in the United States. Just think of the challenge to mathematicians and business-systems men.

### **Q. My school work has emphasized fundamentals. Will General Electric train me in the specifics I need to be effective?**

A. Yes, the Manufacturing Training Program is designed to do just that. Seminars which cover the sub-functions of manufacturing will expose you to both the theoretical and practical approaches to operating problems. Each of the succeeding jobs you have will train you further in the important work areas of manufacturing.

### **Q. After the Program—what?**

A. From that point, your ability and initiative will determine your direction. Graduates of the Manufacturing Training Program have Company-wide opportunities and they continue to advance to positions of greater responsibility.

*Progress Is Our Most Important Product*

**GENERAL  ELECTRIC**



ILLINOIS

No. 5 - 25c

# TECHNOGRAPH

UNIVERSITY OF ILLINOIS  
MAR 4 1963  
LIBRARY



# Men who do nothing but Think

A phenomenon of modern America is the so-called "think company." It owns no factories, manufactures no products and makes no shipments, but just "thinks" about problems--and brilliant ways to solve them.

We have a number of "think companies" at Westinghouse. One is a group of scientists who do almost nothing but seek basic knowledge, like the production of light by solids and the origin of magnetism. Other Westinghouse scientists apply basic knowledge to that most demanding of all problems ... national defense. And there is still another group whose principal job is to think about what products will be needed in the American home 10 or 15 years from now.

Out of this kind of thinking at Westinghouse have come startling advances in atomic power, the launching system for Polaris, the super magnet, and other developments.

The achievements of Westinghouse scientists in the past are the best guarantee of new ones in the future.

For information on rewarding career opportunities at Westinghouse, an equal opportunity employer, talk with our representative when he visits your campus, or write L. H. Noggle, Westinghouse Educational Department, Ardmore and Brinton Roads, Pittsburgh 21, Penna. You can be sure ... if it's **Westinghouse**

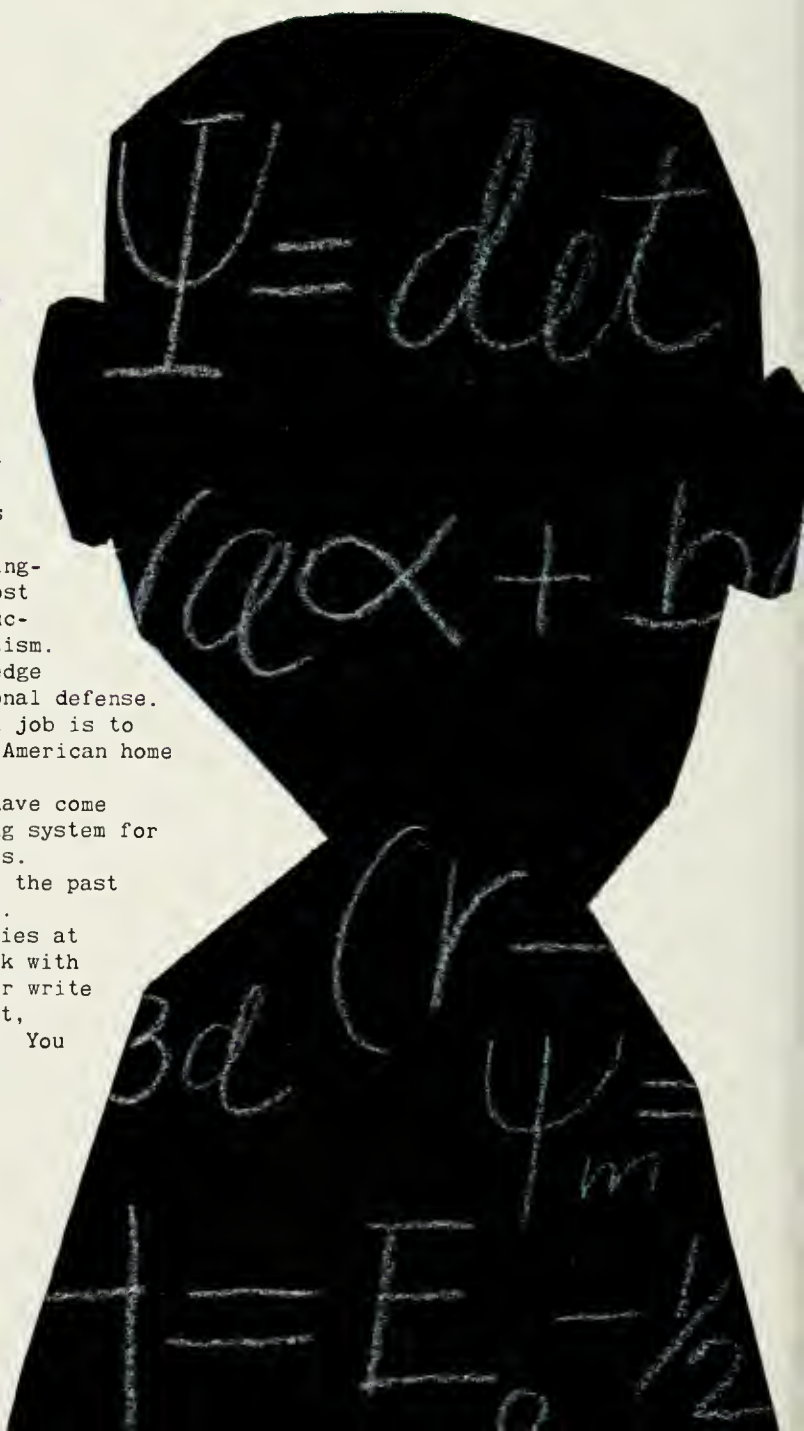



**Editor-in-Chief**

Wayne W. Crouch

**Business Manager**

Gary Daymon

**Production Manager**

Scott Weaver

**Circulation Manager**

Larry Campbell

**Editorial Staff**

Art Becker  
Thelma McKenzie  
Ted Morange  
Jim Walters  
Stuart Umpleby

**Business Staff**

Phillip Johnson  
Wayne Worthington

**Production Staff**

Mike Glowacz

**Circulation Staff**

Bob Bittner  
Paul Gihring  
Dick Kolb  
George Muellner

**Photography**

Joe Figueira

**Secretary**

Kathie Liermann

**Advisors**

R. W. Bohl  
P. Bryant  
W. M. Hudson  
E. C. McClintock

# THE ILLINOIS TECHNOGRAPH

Volume 78; Number 5

February, 1963

## Table of Contents

ARTICLES

Vehicle of the Future.....	Stuart Umpleby	10
U. of I. Highway Safety Center.....	Kaliopee Molagaris	14
Engineering and Science Weekend.....		16
Earth's Last Frontier.....	Wayne Crouch	24
The Fuel Cell.....	Wally Schroer	32

.....

FEATURES

TECH Says.....	Gary Daymon	5
The Dean's Page.....	Dean H. L. Wakeland	7
Technocutie.....	Photos by Joe Figueira	22
News and Views at the U. of I.....		28
Technoquips .....		40

**MEMBERS OF ENGINEERING  
COLLEGE MAGAZINES ASSOCIATED**

Chairman: J. Gale Chumley  
Louisiana Polytechnic Institute  
Ruston, Louisiana

Arkansas Engineer, Cincinnati Cooperative Engineer, City College Vector, Colorado Engineer, Cornell Engineer, Denver Engineer, Drexel Technical Journal, Georgia Tech Engineer, Illinois Technograph, Iowa Engineer, Iowa Transit, Kansas Engineer, Kansas State Engineer, Kentucky Engineer, Louisiana State University Engineer, Louisiana Tech Engineer, Manhattan Engineer, Marquette Engineer, Michigan Technic, Minnesota Technologist, Missouri Shamrock, Nebraska Blueprint, New York University Quadrangle, North Dakota Engineer, Northwestern Engineer, Notre Dame Technical Review, Ohio State Engineer, Oklahoma State Engineer, Pittsburgh Skyscraper, Purdue Engineer, RPI Engineer, Rochester Indicator, SC Engineer, Rose Technic, Southern Engineer, Spartan Engineer, Texas A & M Engineer, Washington Engineer, WSC Technometer, Wayne Engineer, and Wisconsin Engineer.

**The Cover: by Bill Small**

Bill's GEM

Copyright, 1963, by Illini Publishing Co. Published eight times during the year (October, November, December, January, February, March, April and May) by the Illini Publishing Company. Entered as second class matter, October 30, 1920, at the post office at Urbana, Illinois, under the Act of March 3, 1879. Office 215 Engineering Hall, Urbana, Illinois. Subscriptions \$1.50 per year. Single copy 25 cents. All rights reserved by *The Illinois Technograph*. Publisher's Representative: Littell Murrary-Barnhill, Inc., 737 North Michigan Avenue, Chicago 11, Ill., 369 Lexington Ave., New York 17, New York.

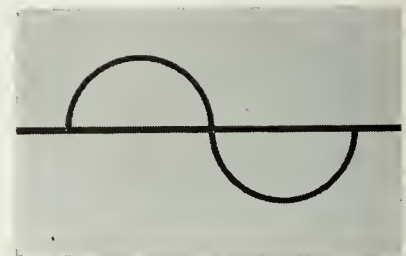
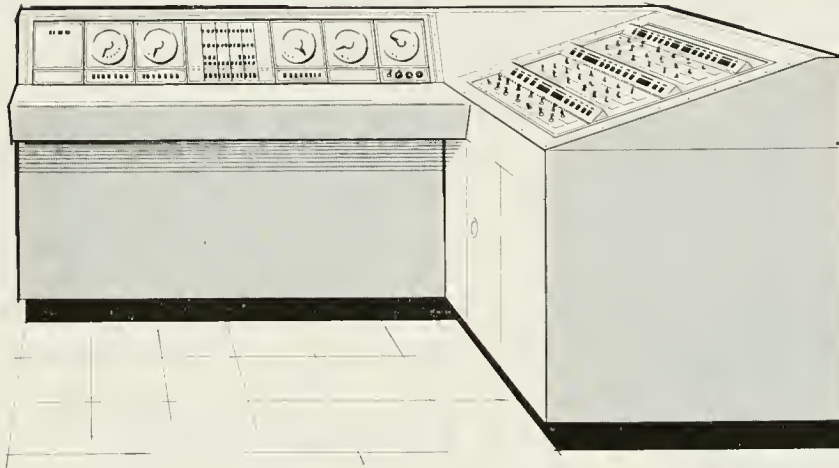

# CONTINUOUS PRECISION

The flick of a switch anywhere in the electric service area of the Wisconsin Electric Power Company system will be under the "watchful eye" of a special purpose on-line analog computer by the end of 1963. Power requirements of the system's approximately 600,000 customers will be known at a given instant at the system's power supply office in Milwaukee. The computer will analyze the electrical needs and anticipate the probable results of load dispatcher action and will automatically control the loading on individual generators which make up the system's 1,925,210 kw of generating capacity. In addition it will regulate the flow of energy over the company's interconnections with neighboring utilities and adjust for minute changes in frequency.

The computer will provide "continuous precision" in executing the rules and formulas developed periodically by company engineers in order to achieve minimum costs in the production of electrical energy. Computers are not new tools to company engineers who use them extensively to improve present performance and to plan the power systems of tomorrow. Write our Employment Placement Division for information about challenging engineering assignments in many fields.

## WISCONSIN ELECTRIC POWER COMPANY SYSTEM

Wisconsin Electric Power Co.  
MILWAUKEE, WIS.

Wisconsin Michigan Power Co.  
APPLETON, WIS.

Wisconsin Natural Gas Co.  
RACINE, WIS.

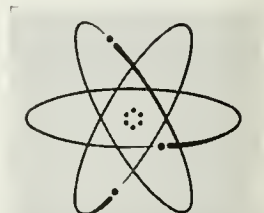





## To catch an atom . . .

Did you know that only one in every 140 uranium atoms found in nature can be split to produce usable nuclear energy? It takes fantastically intricate equipment to capture these elusive atoms. The people of Union Carbide are doing it in a plant at Oak Ridge, Tennessee, large enough to hold 35 football fields.

► Many people thought the uranium separation process too complex to work. For example, pumps had to be developed, that run faster than the speed of sound . . . filters made with holes only two-millionths of an inch across. Union Carbide scientists and engineers not only helped design such a plant and made it work, 20 years ago, but they have been operating it ever since. Union Carbide also operates other vital nuclear energy installations for the U.S. Atomic Energy Commission. One is Oak Ridge National Laboratory, the largest nuclear research center in the country. ► To handle such big research and production jobs requires big, experienced industrial companies. It is only because of their extensive resources and skills that it is possible to take the giant steps needed to bring laboratory developments to full-scale production quickly and successfully.

### A HAND IN THINGS TO COME

**WRITE** for the booklet, "Union Carbide's Twenty Years in Nuclear Energy."

January 18, 1963, marked the 20th anniversary of the Corporation's work at Oak Ridge.

Union Carbide Corporation, 270 Park Avenue, New York 17, N. Y. In Canada, Union Carbide Canada Limited, Toronto.

**UNION  
CARBIDE**

YES  
 NO

Would you like to choose from a broad spectrum of openings?

 YES  
 NO

Would you welcome an early chance to work on whole projects?

 YES  
 NO

Do you give high priority to fewer steps to the top?

 YES  
 NO

Is choice of geographical location important to you?

 YES  
 NO

Do you tend to prefer a formal training program?

 YES  
 NO

Will employee benefits strongly influence your decision?

 YES  
 NO

Can you handle the challenges of early responsibility?

 YES  
 NO

Do you welcome individual attention by management?

 YES  
 NO

Is job security one of your most important factors?

 YES  
 NO

Is unlimited growth opportunity an important prerequisite?

## Test yourself. Are you a small or large company man?

If you answered "yes" to six or more questions, it indicates that you are strongly attracted by the advantages of *both* large and small companies. If so, you might be especially interested in Babcock & Wilcox.

*B&W* is certainly a large and progressive company. Its 1961 sales, for example, were more than \$300 million. And every year, B&W invests many millions of dollars in research and development. B&W can offer you all the advantages of a large com-

pany — formal training program, wide variety of job openings (16 plants in 8 states), plus the security and benefits of a large, 95-year-old organization.

*B&W* can also be considered a small company. There are 150 larger industrial companies in the U.S. Growth opportunities are enormous. Yet only 64 bachelor-level students will be hired in 1963. This select group will be given an opportunity to work on important projects at an

early stage in their professional careers.

Right now, B&W has challenging job openings for both graduate and undergraduate engineers and scientists, including E.E., Ch.E., M.E., Met. E., Cer.E., chemists, and physicists. Why not write for more information? J. W. Andeen, The Babcock & Wilcox Co., 161 East 42nd Street, New York 17, New York.

# Babcock & Wilcox



# Awareness - *The Key to College Improvement*

## *The key to college improvement through Student Evaluation and Opinion*

Educators and students agree that the free exchange of ideas between instructors, administrative leaders, and undergraduate engineering students is essential for a progressive Engineering College. Yet administrators and educators seem perplexed at the lack of constructive student evaluation and criticism. (See Dean Wakeland's article, STUDENT COMMENT AND OPINION, page 7.)

At first glance the lack of undergraduate student interest and criticism on the engineering campus may seem, as many people have suggested, due to the fact that students see their college through eyes lined with nothing but future dollars and cents. A closer inspection, however, will reveal that a lack of awareness of their college and its activities is the main barrier. All too often a student will "vent his spleen" only to be told that his "gripe" is well known and the condition is already being rectified. Needless to say, only one such display of unawareness is enough to discourage any would-be crusader.

The missing ingredient is a reliable and consistent link between student thoughts and evaluations on one side and faculty, research, and administrative activities and proposals on the other.

Student awareness breeds interest, pride, and respect—the backbone of valuable student evaluation and opinion. In general, the engineering student has a meager and often false sampling of the activities flowing within the veins of the twelve acres he patrols daily. Within his own department the average student is not even familiar with three specific research projects, two well-known developments his department and faculty have pioneered, or one proposed curricula change. When such topics as reinforced concrete, transistors, and sound movies are mentioned, the student replies, "Yes, I've heard of them!" without once realizing they were developed and perfected on the University of Illinois engineering campus. Like-

wise, the names of noted faculty members such as Bardeen, Kerst, Tykociner, and von Foerster are regarded with a similar lack of awareness.

Little if any of this unawareness can be attributed entirely to the student. For instance, many students have been "guinea pigs" for new instructional techniques without being aware of it before or after the course. How can a student evaluate the unknown? A similar qualified cloak of secrecy surrounds research projects and proposed curricula changes. Is the undergraduate student really such an irrelevant element on his own campus?

Sure, the faculty can counter with, "What do these guys need—a seeing-eye dog?" The answer is no. What is needed is a direct "pipeline of awareness" to the engineering student whose college is too big for him to peep behind every door and drop in on every conference. Once the student is aware of what *is* being done, he can unhesitatingly and intelligently evaluate, criticize, and bring into view that which *is not* being considered.

Perhaps one of the most valuable pipelines to promote student "play-back" would be an undergraduate weekly newsletter or similar publication outlining new findings in research, administrative actions and proposals, and the activities of Engineering Council. If the College of Engineering sincerely wishes to advance and improve the college, it should not knowingly or unknowingly hide behind a circumstantial cloak of secrecy.

For an effective student-faculty "play-back" to exist, the student engineer must have pride in his college and the background, interest, and awareness to work not only *for* but *with* his college. Pride, interest, and background are generated by awareness—the missing link for college improvement through student evaluation and opinion. If the undergraduate's opinion is really wanted, why does the College of Engineering open only its classrooms?

—Gary Daymon

Ambitious, talented young men with new ideas and a zest for challenge will find unusual opportunity at Delco Radio Division, General Motors Corporation.

Delco enjoys an enviable reputation for attracting and retaining top-notch talent in the electronics field. We feel it's a result of the atmosphere at Delco where the individual finds opportunity to exercise and develop his abilities to the fullest.

# OPPORTUNITY is yours at DELCO

solid state electronics ●



Our recently completed 125,000 sq. ft. Research and Development Center provides unlimited facilities for utilizing these abilities in the investigation and development of such space age devices as semi-conductors, computers, static inverters, thermoelectric generators, power supplies, machine controls, to name but a few of Delco's current projects.

To this combination of outstanding talent and facilities we attribute our pattern of success over the years. To this same combination we look for continued success as we assault the challenges of the future.

Why not cast your lot with a leader in the field? Arrange an appointment with our interviewer when he visits your campus, or for additional information write: Mr. C. D. Longshore, Supervisor  
—Salaried Employment.



DELCO RADIO DIVISION OF GENERAL MOTORS

KOKOMO, INDIANA

*An equal opportunity employe.*



# STUDENT COMMENT AND OPINION

Dean H. L. Wakeland

In any true educational experience there must be a meeting of minds between instructor and student. The thoughts of the instructor must be transmitted through oral, visual or written means to the student. This does not mean that the student fully understands each phrase or example, but that the seed of thought has been planted and will grow with assistance from the student and nourishment by the instructor.

How do you determine if the planting has been successful? — through quizzes? — final examinations? — term papers? These methods measure only whether growth has taken place. They will not indicate why growth hasn't taken place or why the transplanting wasn't successful in the first place. Only through a "play-back" from the student, can the instructor determine his effectiveness and success as a teacher. The "play-back" from students is more than the mere recording of quiz or examination grades—it is the student's evaluation of the instructor's teaching methods, attitudes and preparation as well as the student's evaluation of his own attitude and shortcomings.

Students seldom volunteer this type of "play-back." Perhaps because they fear retaliation—or because of indifference—or due to the fact they are not encouraged to do so. No one wishes to invite the spontaneous and seemingly irresponsible type of demonstrations university students sometimes generate, but honest and sincere expressions are welcomed and needed from students.

Unfortunately, the most radical or cleverly stated criticisms are the ones most often published in campus newspapers and few campus publications seek factual student opinion. When did the last article appear in this publication which either complimented or questioned the engineering instruction or curricula at the University of Illinois?

It is true that student expression is sometimes killed or diverted by outright censure or indifference, but this is the exception rather than the rule. We expect students to be mature and self-sufficient in their attitudes toward education and in performance of studies. Shouldn't we also expect their judgement and evaluation to be valuable?

At one time or another we all get "hot under the collar" and in the heat of a given situation make a slightly erroneous statement. But when a person "blows off steam" he is usually also pretty close to the truth. Actually, I am continually amazed by the fairness of students in their attitudes and usually find their evaluations quite factual. In addition, students are often in the best position to give a judgement. For instance, who is most directly effected by the level of classroom instruction? Who has more exposure to a new instructional method used than the student? He is often in a better position to make these evaluations than any one else.

"Play-back" from students is not only desirable but needed to continually evaluate and maintain a strong engineering undergraduate program. Though individual observations are welcomed, re-

member there is strength in an organized approach or in numbers. If you feel strongly about a specific matter, air your views in a student society meeting or to the Engineering Council. If they support you, your criticism will receive greater consideration.

Recently the Student Senate made a survey on the quality of teaching at the University of Illinois. It was well organized, fair, and represented the opinions of a reasonably large number of students. They found that the majority of students considered the teaching of the University to be neither excellent nor poor, but good. On the basis of some of their more specific conclusions and recommendations there is a good chance that some changes will be made in improving and evaluating instructors and teaching methods. In your opinion, what is the quality of teaching in the College of Engineering? Is the engineering advising system adequate? Which courses have been the least challenging? Has your interest in engineering been dulled or sharpened and why? Do you feel that you are getting the very best education available in your specialized area? Is registration or pre-registration unduly cumbersome?

We simply do not get the "play-back" from engineering students which is needed. If you earnestly believe that certain changes or improvements are needed in our undergraduate engineering program, or in a specific course, or in student activities—you have a responsibility as well as a right to voice your opinion.

# NASA...your place in space

## NASA programs encourage swift professional growth for the engineer or scientist launching his career

You can accelerate your career swiftly as a professional staff member of the National Aeronautics and Space Administration. Stimulating assignments, unequalled resources, liberal programs of educational assistance, early responsibility—all help hasten the professional growth of the engineer or scientist who chooses NASA for his initial career position.

Each NASA research center offers its own comprehensive plan to help advance your knowledge and speed the time when you can contribute at the peak of your capacity. The plans differ from center to center, but this summary is generally valid throughout the NASA complex:

### NASA Installations Maintain University Ties

NASA centers have established close relationships with nearby universities. As a professional staff member, you may pursue graduate study either in the evening at NASA's expense or during regular working hours on full salary. And, if necessary to fulfill university requirements for a graduate degree, you may become a resident student, also on full salary.



NASA encourages advanced study in astronautics, physics, electronics, chemistry, metallurgy, mathematics, astronomy, and geophysics, as well as aeronautical, mechanical, electronic, electrical, nuclear, ceramic, and civil engineering, engineering mechanics, and engineering physics.

### Guggenheim, Sloan, Brookings Fellowships Available

Additional avenues of opportunity will be open to you because NASA participates



in fellowship programs of the Guggenheim and Sloan Foundations and the Brookings Institution. Right now, as a result of this participation, NASA staff members are attending Cal Tech, M.I.T., Harvard, and other leading schools, receiving full salary, expenses, and per diem.

NASA helps you keep abreast of the latest developments in your field by permitting frequent attendance at major technical conferences in this country and abroad.

### Unique Intern Programs Increase Technical Competence

The NASA centers offer exhaustive in-house educational opportunities as well, including the unique Intern Programs. The regular in-house activities include lectures, seminars, films, and expense-paid trips to other organizations. The Intern

Program is somewhat different. As an Intern, you study and work closely with a senior NASA scientist or engineer, a leader in his—and your—field. This is an informal and exceedingly productive arrangement, which usually lasts for six months. The Intern Program is designed to bring you very rapidly to the forefront in a special technical area.

### Get All the Facts About a NASA Career

Learn more about your future with NASA. Contact your College Placement Officer to arrange an interview with NASA representatives visiting your school. Or send a letter outlining your interests and background to the Personnel Officer at any one of the following NASA locations: NASA Goddard Space Flight Center, Greenbelt, Md.; NASA Langley Research Center, Hampton, Va.; NASA Lewis Research Center, Cleveland, Ohio; NASA Marshall Space Flight Center, Huntsville, Ala.; NASA Ames Research Center, Mountain View, Calif.; NASA Flight Research Center, Edwards, Calif.; NASA Manned Spacecraft Center, Houston, Texas; NASA Launch Operations Center, Cocoa Beach, Fla.

NASA is an equal opportunity employer. Positions are filled in accordance with Aerospace Technology Announcement 252-B.





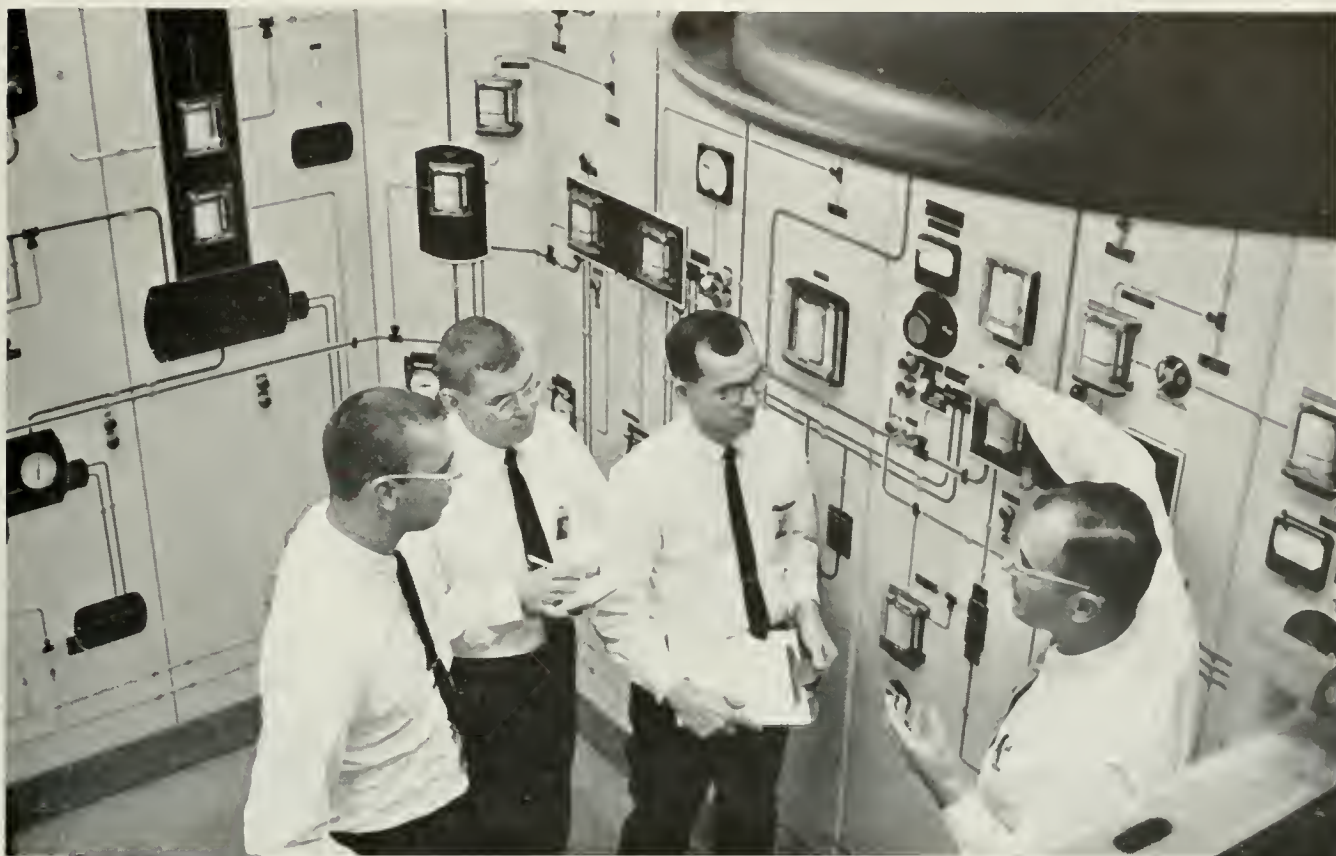

## LYCRA®

### A production triumph for technical men

Few women enjoying their 4-ounce LYCRA and nylon bathing suits will care how LYCRA spandex fiber got to be a third lighter than rubber and three times as restraining.

But the technical men who produce LYCRA at our Waynesboro, Va., plant do care. For LYCRA is tough to make. As one technical man put it, "LYCRA requires the greatest care, the finest controls, the most complex chemical reactions and manufacturing processes, the most delicate handling. The fact that it is being made—and of the highest quality—is a stunning achievement."

Considering that LYCRA is just one of hundreds of such products developed and manufactured by Du Pont, there's little reason to wonder why we need so many good chemical, mechanical, industrial and electrical engineers, physicists, mathematicians and chemists.

And on the production line, their responsibilities are big. Especially for some of them—like the new supervisors in our photo—who were in college like yourself just a few years ago. For not only must they excel in their respective technical specialties—they must also have leadership abilities and strong feelings for sound employee relations.

If a career in production—where you might handle everything from intricate process problems to the shipment of finished products—appeals to you; or if you're interested in research, development or sales, write to us.

Use our coupon. You'll receive information about employment opportunities at Du Pont, and, if you like, about LYCRA and other new Du Pont products featured in our "Opportunities" series. Mail coupon today.



BETTER THINGS FOR BETTER LIVING...THROUGH CHEMISTRY

An equal opportunity employer

E. I. du Pont de Nemours & Co. (Inc.)  
Nemours Building, Room 2531-2, Wilmington 98, Delaware  
Please send me the literature indicated below.

- Du Pont and the College Graduate
- Mechanical Engineers at Du Pont
- Engineers at Du Pont
- Chemical Engineers at Du Pont
- "Opportunities" series technical information

Name \_\_\_\_\_

Class \_\_\_\_\_ Major \_\_\_\_\_ Degree expected \_\_\_\_\_

College \_\_\_\_\_

My address \_\_\_\_\_

City \_\_\_\_\_ Zone \_\_\_\_\_ State \_\_\_\_\_

# VEHICLE OF THE FUTURE

By Stuart Umpleby, ME '66

The world's transportation is in a rut. While astronauts orbit the earth and scientists take potshots at Venus, earth-bound men move about in automobiles and ocean liners which are actually only improvements on the chariot and gal- leon. What the alert space age man needs is a vehicle similar to a flying saucer to whisk him around on earth while spaceships explore the universe. Such a vehicle is the ground effect machine, which rides on a cushion of air a few feet above land or water.

Several articles on ground effect machines appeared in popular scientific magazines when the idea became widely known soon after 1959. This article will bring the reader up to date on this new space age vehicle.

## The Ground Effect Principle

Air cushion vehicles are able to travel above the surface of the earth without the use of wheels or hydrofoils because of the ground effect principle, which states that a body of fluid trapped between a solid structure and the ground can be made to sustain the weight of that structure at an appreciable distance above the ground. An airplane experiences the ground effect whenever it flies close to the ground. As the air above the earth is shoved up under the wing, lift increases and drag decreases, a phenomenon still only vaguely understood by scientists. A falling body also experiences the ground effect. Just before the object strikes the ground, air is compressed between the object and the ground, and a vertical push results. The ground effect principle is utilized by the lift systems of all air cushion vehicles, and the great diversity of lift systems invented reflects the ingenuity being brought to this new field.

## Lift Systems

(1) The open plenum ground effect machine is essentially an inverted bowl. Although it is the simplest and cheapest type to build, several disadvantages offset its economy of construction. The large plenum chamber takes up valuable cargo space; forward flight disrupts the supporting cushion unduly; and hover heights are only a few inches, even for big machines.

(2) The peripheral jet GEM (Ground Effects Machine) generates



Figure 1. The hovercraft pictured above is presently being used in Britain to ferry passengers between pairs of English cities and across the English channel.

and maintains its cushion from air blown downward and inward around the perimeter of the vehicle. The purpose of the curtain of air is to contain the air cushion formed beneath the vehicle. Experience has shown that peripheral jet devices are capable of hovering several feet higher than plenum vehicles of the same size, especially when flexible skirts are hung from both the outer and inner edges of the peripheral opening. By using flexible skirts of length equal to the normal hover height, clearance can be doubled or, for a specified clearance, power requirements can be halved. Peripheral jet GEMs are also more suitable for high speed flight since the fast moving air in the curtain is more difficult to blow away than the almost stationary mass of air in the plenum chamber.

(3) The water curtain GEM theoretically has a startling advantage over air curtain devices. Designed to operate only over water, it has a pumping system that projects into the water and delivers water to the periphery to replace the curtain. Since its water curtain is more dense than an air curtain, air pressure does not leak away as rapidly, and cushion power can be drastically reduced. However, this idea has proven impractical for several reasons: The

weight of the water carried along is too great; the drag of the pumping system inlet, which projects into the water, seriously limits forward speeds; and too many power systems are involved, one for cushion air, one for water, and one for propulsion.

(4) The recirculation system is an attempt to improve the peripheral jet. The process of expelling air around the periphery of a vehicle is somewhat inefficient since the energy in this air is lost once it leaves the underside of the vehicle. Recovery of this energy through recirculation results in significant improvement in efficiency. This system has two more distinct advantages. First, since the air being reused is already moving at the speed of the vehicle, there is no momentum drag, which results when a vehicle must use part of its propelling power to impart forward velocity to the stationary ingested air. Second, objectionable clouds of dust and water spray are eliminated by having air enter the bottom instead of the top of the machine.

(5) The labyrinth seal concept conserves cushion power by reenergizing the cushion air through a series of internal passages before it escapes. Models have shown that the power saving can be as much as forty per cent for a three



stage labyrinth, but the mechanical complexity of this scheme, plus its high probable maintenance cost have dissuaded builders thus far.

(6) The ram wing concept is merely an airfoil section with end plates. The vehicle achieves dynamic lift as air piles up under the wing between the end plates. Since the ram wing has no hovering capacity, it will have to be combined with another lift system for smooth transition into and out of its type of ground effect flight.

(7) The diffuser system is similar to the ram wing in that it relies on forward velocity to provide the working air. The aerodynamic principle utilized by the diffuser system is that air gains pressure as it loses velocity. The air of the atmosphere, moving at high speed in relation to the vehicle, passes into the space bounded by the bottom of the vehicle, the ground, and side jets, which serve to channel and contain the oncoming air. The air then expands into the larger internal cavity, but since air is continually being forced into the cavity, some of the air must leave through the smaller opening at the rear of the vehicle. This opening serves as a bottle neck and the result is that the original high velocity air is considerably slowed as it passes beneath the machine. In this way the oncoming air gains sufficient pressure to support the vehicle.

(8) The levapad is a lift system quite different from those discussed previously. It is used on vehicles called levacars, that ride on a pair of smooth, square tracks, yet separated from the tracks by air under very high pressure. The air film, which is only a few thousandths of an inch thick, lifts the vehicle and lubricates the tracks. Vehicles of this type would travel at speeds between two hundred and five hundred miles per hour.

**Control Systems**

Ground effect machines in general have unique advantages and disadvantages when compared to present types of

transportation. Since they have no contact with the ground they can travel over any level surface—land, water, ice, snow, mud, marsh, and sand. But the fact that there is no ground friction is the cause of the vehicle's two major problems—control in cross winds and control over sloping surfaces.

Since GEMs can be so easily blown about, they will never replace the automobile for downtown shopping; a gentle breeze during rush hour would create havoc. However, over depressible surfaces such as water, there is some keel effect which would aid stability in cross winds.

Riding in a GEM is like sitting on a board separated from a huge piece of glass by a layer of marbles, and controlling a GEM in rolling terrain is like controlling a saucer sliding down an icy hill. Nevertheless, the solution to this problem is simple, operate only on very level surfaces such as rivers and lakes, or on special ground effect highways, which could be no more than a grass covered, concave ditch similar to a shallow bobsled run.

Numerous ideas have been suggested for controlling GEMs. The following are a few of these: (1) venting the air chamber to provide thrust opposite to the direction traveled; (2) deflection of the air curtain; (3) tilting the machine by increasing lift on one side so that the vehicle slides down the distorted air cushion; (4) using an external engine, which can be pivoted, or, if two are used, can provide variable thrust; and (5) using air rudders for high speeds. At low speeds tilting the machine is the simplest and most practical method. At high speeds either air rudders or separate engines can be used.

**Ground Effect Machines Abroad**

The great versatility of this new type of transportation, has aroused interest around the world. Britain, the United States, Russia, Sweden, the

*(Continued on Next Page)*

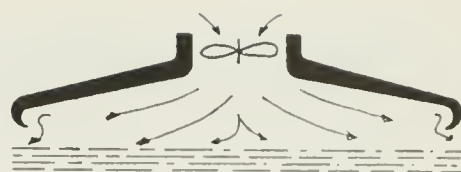

(1) Plenum chamber



(2) Peripheral jet

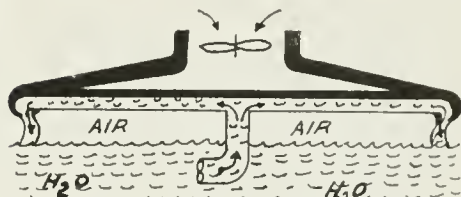

(3) Water curtain

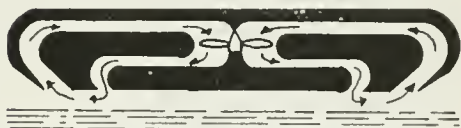

(4) Recirculator



(5) Labyrinth seal

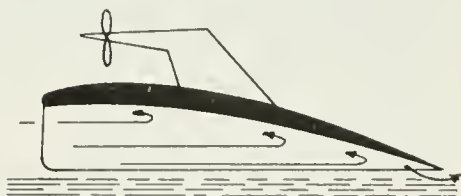

(6) Ram wing

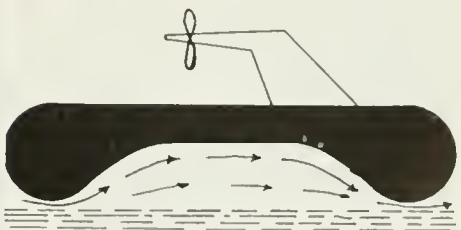

(7) Diffuser

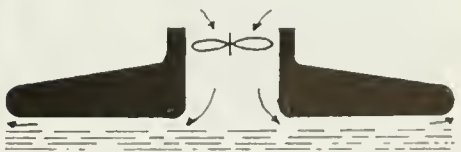

(8) Levapad

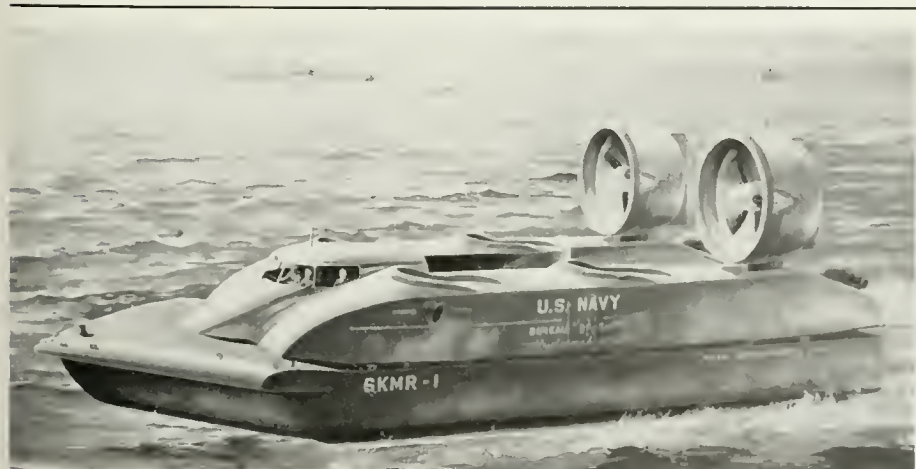

Figure 2. The Hydroskimmer, an experimental GEM built for the Navy, will be tested on Lake Erie this May.

Netherlands, France, Italy, and Switzerland are all conducting research on GEMs. The Russians are reported to be making a dozen of these vehicles. Six will be used on the Caspian Sea, and six will go to the great rivers of Siberia.

Although the United States is abreast of, if not in some ways ahead of, researchers elsewhere, Britain is at least a year ahead of everyone else in actual operation of ground effect machines. Last summer the British ran a ferry service across the Dee estuary in Wales, carrying twenty-four passengers on each thirty minute run from Rhyl to Wallasey—a trip which takes two and a half hours by rail or highway. The British also take credit for the most advanced GEM built so far, the Saunders-Roe SRN 2, a twenty-seven ton vehicle now undergoing trials. This hovercraft, as they are called in Britain, is designed to carry sixty-six passengers over a normal range of two hundred miles, cruising at seventy knots. It will be used for ferries from the southern coast of England to the Isle of Wight, from Weston to Cardiff on the Bristol Channel, and from the cliffs of Dover to Calais on the French coast.

#### GEMS in The United States

The feasibility of ground effect ferries will be tested in the United States at the 1964 World's Fair in New York. A hoverboat excursion will show visitors the New York Bay area.

This May, Bell Aerosystems Company will test its twenty-five ton Hydro-skimmer on Lake Erie. The sixty-five foot long vehicle will carry a two man crew with a five ton payload two feet above land or water at a speed of seventy knots. The Navy, for whom the vehicle is being built, will use it to conduct research on military applications for GEMs.

A much more advanced vehicle is being built for the U. S. Maritime Administration. This two hundred ton GEM, designed for open sea use will have cruising speeds of about one hundred and forty knots and hover heights up to four feet. If the MarAd vehicle is

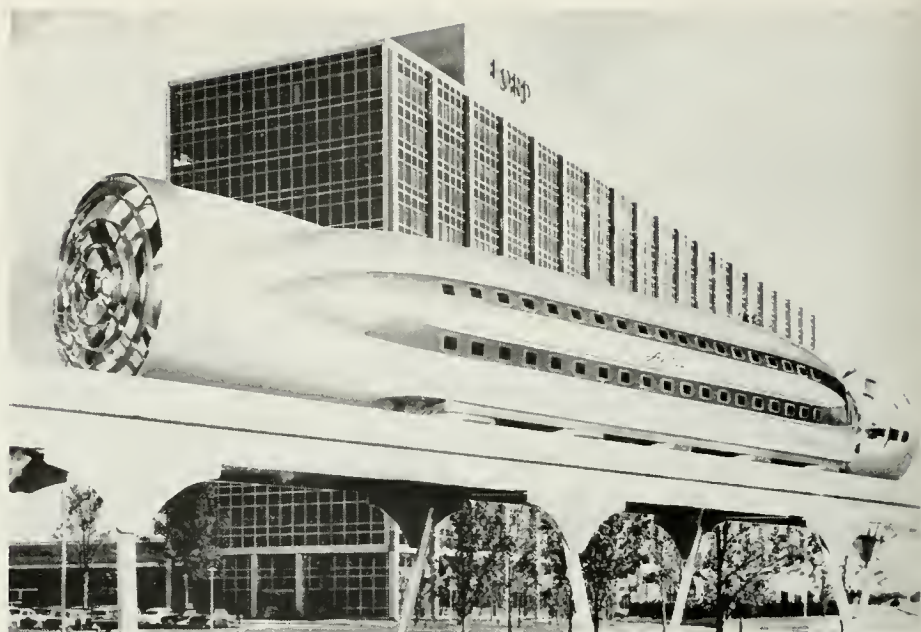

Figure 3. Ford's aerolus, a two hundred passenger levacar, could transport passengers between cities at speeds between two hundred and five hundred miles per hour.

successful, the way will be clear for the optimum one thousand ton super GEM which could be used for rapid transport of cargoes and passengers around the world.

#### GEMs in The Future

The trend, however, is not just toward bigger and bigger GEMs; indeed, these machines can be used for everything from exploring the arctic to opening such previously unnavigable rivers as the Congo and the Amazon.

On inland waterways the GEM is ideal. It can carry heavy loads at remarkable speeds in any weather and no matter what the conditions of the river. Neither ice nor rapids nor subsurface snags or sand bars can slow such a vehicle. For both ocean going and river going GEMs, harbor facilities are not needed; the vehicles can drive up on the land before stopping.

Transportation between centers of heavily populated areas can be remarkably speeded by use of levacars. Fig. 1 shows a scale model of Ford Motor

Company's Aerolus, named for the Greek god of the winds. This two hundred passenger levacar eliminates the need for transportation between city and airport, which is frequently a time consuming part of an air trip. The ninety-two mile rail trip from the center of New York city to downtown Philadelphia would take half an hour. The levacar is also inherently safe; even in the event of total engine failure, the vehicle would slide to a comfortable stop. Because of considerable interest in levacars shown by some of America's leading railroads, preliminary design studies have been made for a levatrain, composed of one hundred passenger levacars linked with fifty passenger propulsion units on the front and rear.

Ground effect machines would also make excellent emergency vehicles. In flooded regions GEMs would operate on the surface but would not be affected by raging, turbulent water. Fires could be quickly and safely brought under control, and GEMs could be used on rescue missions to areas impassable to other surface vehicles.

The military is considering using the ground effect machine for such tasks as transport landing, high speed patrol work, antisubmarine warfare, and mine counter-measures. The advantage for using GEMs on these missions is obvious; a torpedo can hardly sink an object not in the water.

These examples illustrate only a few of the uses to which GEMs may be put in the future.

Although few GEMs are in operation now, their future certainly looks promising, for if anything can get transportation out of its rut, the ground effect machine can. ◆◆◆

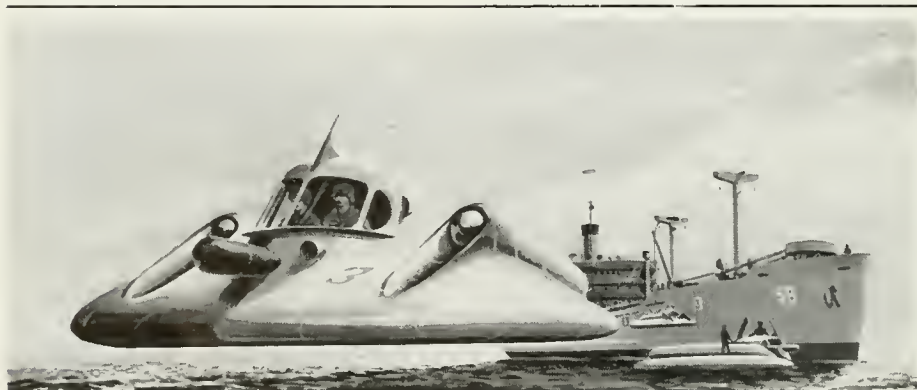
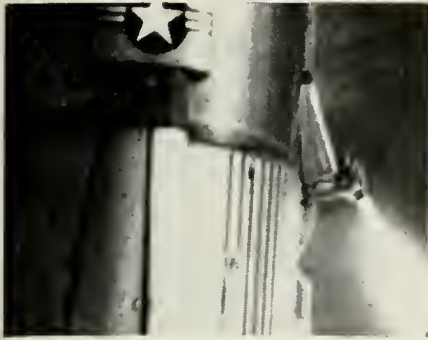

Figure 4. Ground effect sub-hunters operating from transports could patrol vast areas of ocean and could not be damaged by torpedos.





FROM THE LAUNCHING TO THE TARGET, EVERY MAJOR U. S. MISSILE DEPENDS UPON SYSTEMS, SUB-SYSTEMS OR COMPONENTS DESIGNED, DEVELOPED OR PRODUCED BY BENDIX TALENTS



FOUR OF THE U.S. SPACE DETECTIVES THAT SPOT, SHADOW AND REPORT ON EVERY MAN-LAUNCHED OBJECT IN OUTER SPACE DEPEND ON EQUIPMENT OR TECHNICIANS, OR BOTH, SUPPLIED BY BENDIX

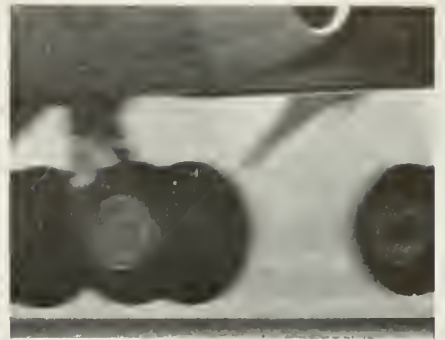

AT TAKE-OFF, IN THE AIR, ON LANDING... WHENEVER MAN FLIES, IT'S LIKELY BENDIX EQUIPMENT MAKES HIS TRIP SMOOTHER, SAFER. BENDIX HAS LOGGED MORE FLIGHT TIME THAN ANY NAME IN AVIATION



EVERY TIME YOU BRAKE YOUR CAR, CHANCES ARE YOU DEPEND UPON BENDIX. SINCE 1924 BENDIX HAS DESIGNED AND BUILT MORE BRAKES FOR MORE DIFFERENT VEHICLES THAN ANY OTHER PRODUCER



TODAY, AUTOMATED TAPE-CONTROLLED MANUFACTURING AS DEVELOPED BY BENDIX HELPS TURN BLUEPRINTS INTO FINISHED PRODUCTS, GETS PROTOTYPES INTO PRODUCTION FOUR TIMES FASTER

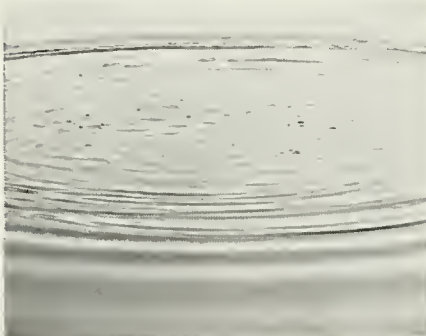

IN THE CONQUEST OF THE UNKNOWN, BENDIX RESEARCH AND DEVELOPMENT IS EXTENDING MAN'S ABILITY TO COMMUNICATE THROUGH THE OCEAN DEPTHS AS READILY AS THROUGH SPACE



WHEN SPACE TRAVEL BECOMES A REALITY, PILOTS WILL RELY ON DEVICES CONCEIVED AND DEVELOPED BY BENDIX TO NAVIGATE, GUIDE AND STABILIZE THEIR SHIPS, AND RETURN THEM SAFELY TO EARTH

## CREATIVE ENGINEERING . . . Q.E.D.

The variety of challenges The Bendix Corporation offers the college graduate is practically unlimited. Bendix participates in almost every phase of the space, missile, aviation, electronics, automotive, oceanics and automation fields. We employ top-notch engineers, physicists, and mathematicians for advanced prod-

uct development to further Bendix leadership in these fields.

Bendix operates 32 divisions and subsidiaries in the United States, and 12 subsidiaries and affiliates in Canada and overseas. Our 1950 sales volume was \$210 million. Last year it was over \$750 million.

Look over the materials we have in

your school's placement office. Talk to our representative when he's on campus. If you'd like a copy of our booklet "Build Your Career to Suit Your Talents," write Dr. A. C. Canfield, Director of University and Scientific Relations, The Bendix Corporation, Fisher Building, Detroit 2, Mich. An equal opportunity employer.

WHERE IDEAS  
UNLOCK  
THE FUTURE



FISHER BUILDING, DETROIT 2, MICH

THERE ARE BENDIX DIVISIONS IN: CALIFORNIA, MISSOURI, IOWA, OHIO, INDIANA, MICHIGAN, PENNSYLVANIA, NEW YORK, NEW JERSEY, MARYLAND.

# U. of I. HIGHWAY SAFETY CENTER

By Kaliopee Malagaris

What will you be doing in 1980? Working? Studying? Vacationing? . . . Or perhaps resting quietly in a six-foot grave? The latter may very well be true since approximately 70,300 persons are destined to die on U. S. highways by that time.

In August of 1961, a Traffic Safety Center was organized in the University of Illinois Engineering College to take positive steps in decreasing this slaughter on our highways. Today the Center coordinates independent highway safety research programs on campus.

In the words of Dr. Baerwald, who directs the traffic engineering group in the Department of Civil Engineering, "The Center's purpose is not to detract, but to add to and coordinate the independent traffic safety studies being conducted on campus. Efforts become more centralized, and groups interested in having research done can do so more efficiently and effectively by contacting only one center." According to Dr. Baerwald, the Center has four major activities: Formal education, extension education, information services, and research.

## Formal Education

In formal education, the Center is evaluating current courses being offered by the University to determine which contribute most to traffic safety. Such fields as traffic administration, driver education, highway engineering, traffic engineering and police administration are being investigated. Many of the Center's personnel feel that psychology, criminology, economics and sociology should become a standard part of the curriculum.

## Extension Education

Extension courses are being taught throughout the state, and additional courses are being planned for public officials, judges, lawyers, engineers, police officers, educators, motor vehicle administrators, driver's license examiners, planners, safety leaders and private citizens who are already working in the highway field.

## Information Services

The Center maintains an informational service and publishes educational material on traffic safety. Anyone having a problem concerning traffic safety can contact the Center's informational service where it will be answered or else referred to another more qualified source.

## Research

Research is perhaps the most important aspect of the Center. Typical of the many research activities is a pilot study of motor vehicle titling practices and procedures which was recently conducted. Dr. Baerwald and Keith Stonecipher of the Civil Engineering Department headed the study which was designed to determine the current and potential benefits of motor vehicle registration and titling information.

Eight hundred questionnaires relating to the value of various types of information were sent to states' attorneys, chiefs of police, county sheriffs, highway and traffic engineers, planning agencies, state and national banks, loan companies, motor vehicle dealers, insurance agencies, highway and traffic safety agencies and

special groups. The questionnaire included statements such as the owner's name, the number of miles the vehicle was driven during the previous year, the body style, the year model, the type of fuel used, whether or not the vehicle operates as an interstate carrier, the number of axles the car has, the name of the dealer, etc. By finding out what uniform information these agencies need, the following can be determined: national, state and regional trends and statistics; the transfer of information between states and the use of various agencies within the state.

The 12 items considered most valuable by the agencies were the owner's name, street address, city or town, county or township, name of the vehicle, make of the trailer, the body style, factory or serial number, information relating to license plate suspensions or revocations, information indicating if the vehicle operates as an interstate carrier. Other requested information included the color of the vehicle, vehicle insurance records, the exact model of the car and information on all lien holders.

When all the data has been complete-



Figure 1. The speed, volume and lateral placement of vehicles traveling along this street on the University of Illinois campus are being recorded as part of a research project on traffic stream characteristics.



ly analyzed, the type of information and form in which it is or would be of most value will be decided. Project personnel will then work with Illinois motor vehicle registration and titling officers and personnel of the American Association of Motor Vehicle Administration to determine what data is currently available, and what additional data is needed.

In another project researchers in the College of Law, under the direction of Dr. Charles H. Bowman, are surveying state laws and federal statutes regarding motor vehicle operations where a road and railroad cross on the same level. Statutes for sound warning devices, visual warning devices, automatic devices, billboards, flagmen, speeds at crossings, advance warning signs, marked pavements, wires over crossings and stops at crossings are being checked against each other.

Data on all states has been gathered, and the best statutes are being compiled. The compilation will be sent to the National Committee on Uniform Traffic Laws under the auspices of the National Safety Council where it will be checked. If found acceptable, it will be mailed to highway departments in all states as the recommended uniform statutes.

#### Student Research

Another area under study is the status of traffic accident reporting. John Glennon, a senior in civil engineering, is determining if there are any differences between the statistics of Champaign County's local police traffic divisions and the State Bureau of Traffic's statistics for Champaign County.

Although still in the preliminary stage of the project, already he is finding discrepancies. "One possible reason for the differences in the bureaus' traffic figures," Glennon says, "may be that the local jurisdictions get the property damage accident report from the policemen whereas the state requires the accident to be reported by the driver himself."

"Another discrepancy may be that the state requires reporting all property damage in excess of \$100. Local agencies want all property damage reported.

"Definition of terms may be another problem. On the local level a personal injury accident is one in which someone requires first aid. If no first aid is administered, the accident is called a property damage accident. However, if in the driver's accident report to the state, he says he developed a headache from the accident, the state classifies the mishap as a personal injury.

"There are times," he continued, "when an accident occurs on a rural road. Those involved might not report the accident to the local police, but feel an obligation to notify the state. A possible remedy may be to include a blank on the state report asking if a local police report was made and by whom."

For the years 1959, 1960, and 1961,

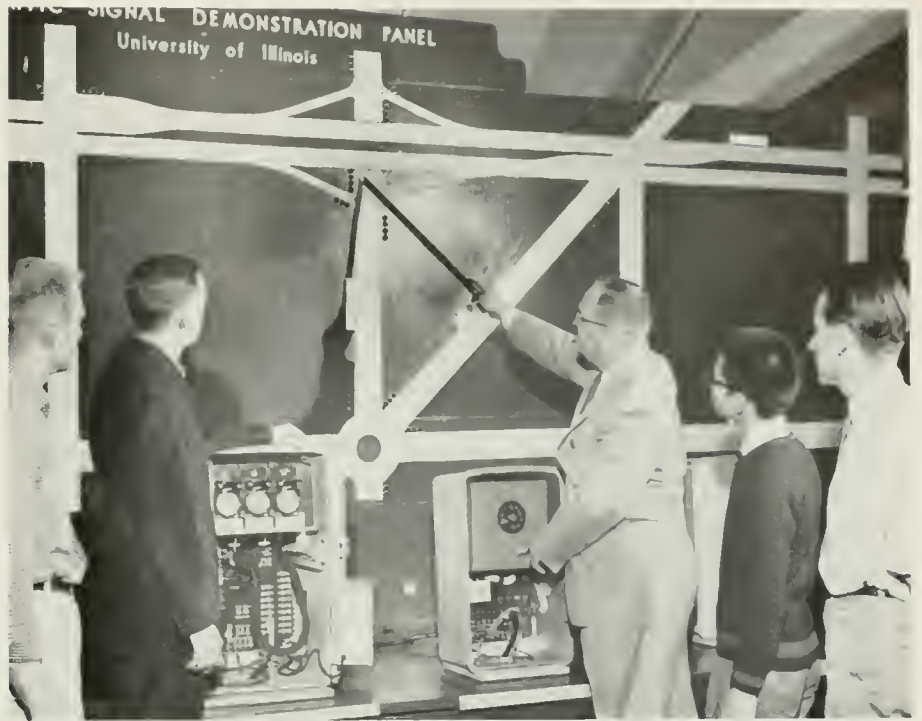

Figure 2. Dr. John E. Baerwold explains the interrelationships between the traffic signal indicators visible to the driver at an intersections and the settings and adjustments that must be made in a traffic signal controller for the intersection.

Glennon has also found a difference in the total number of deaths listed by Champaign County and by the state for Champaign County. "There may be at least two possible reasons for this," Glennon remarked. "One may be that deaths were reported by local jurisdictions within what they believed to be the county line. Another reason is if a death occurs on private property, it is considered a non-traffic death by the state. For example, if a child is playing in a private driveway and is hit by a car backing out of the garage.

"The differences in the local and state figures must be eliminated for a more accurate picture of the state's traffic problems. Accuracy will help for a better planned highway safety program and will channel state funds into the areas most needing improvement."

#### Other Activities

Among its many activities, the Center is also negotiating with a national organization for the physically handicapped to investigate the laws for licensing specially handicapped persons and to study the driving records of these persons. Also it is developing equipment that will measure the dynamic visual characteristics of the driver, that is, develop instruments which will measure "quick decision type visual tests."

#### Center's Historical Background

In 1955 as part of Senate Bill 777 which established an Illinois Division of Traffic Safety in the Illinois Department of Public Safety, the University of Illinois was named as a source of pos-

sible assistance for traffic safety educational and research programs.

A Committee on the Utilization of University Resources for Traffic Safety was established in 1958 and was requested to make recommendations. A survey by the committee revealed that 20 departments within the University were already participating in or were interested in participating in additional aspects of the traffic safety program.

Those showing interest in the idea were: College of Agriculture (extension), College of Law, Departments of Architecture, City Planning and Landscape Architecture, Civil Engineering, Health and Safety Education, Marketing, Mathematics (statistics), Mechanical Engineering, Psychology, Public Health, Radiology, Sociology, Division of University Extension, Office of the Safety Coordinator, Physical Plant Department, Small Homes Council, University High School, University Press and WLL-TV.

Twenty-three state and national organizations were asked for their view on the establishment of the Center. From the American Automobile Association in Washington, D.C., came this reply:

"From the national point of view there is no question that there is great need for a tremendous step-up in research relating to traffic and safety. . . . Today, only a small fraction of one per cent of the money spent on roads is devoted to research. In contrast, in most

(Continued on Page 38, Col. 1)

# ENGINEERING & SCIENCE WEEKEND

## MAY 10 & 11, 1963

at the

UNIVERSITY of ILLINOIS

- Illinois Junior Academy of Science State Fair
- Central Division of the 11th Annual JETS Engineering Exposition and Conference
- Veterinary Medicine Open House
- Engineering Open House

*Free bus service of entire campus for all visitors*

*Individually guided tours available upon request for all  
visiting groups*

FULL DETAILS IN THE NEXT TECHNOGRAPH ISSUE

or write

WALTER HADCOCK  
425 GARNER MRH  
CHAMPAIGN  
ILLINOIS





## “What responsibilities will you start with at W. E.?”

Exciting ones. With plenty of room for your professional development. Western Electric's business depends on new ideas. And new engineers take responsible, immediate part in projects that implement the entire art of telephony—including electronic telephone offices, computer-controlled production techniques and microwave transmission. On many of these exciting advances in communications, Western's engineers work closely with engineers from our research team-mate, Bell Telephone Laboratories. For Western Electric to maintain the Bell System's ultra-high quality standards, extraordinary manufacturing, process

and testing techniques are required. Opportunities for fast-moving careers exist now for electrical, mechanical and industrial engineers, and also for physical science, liberal arts and business majors.

For more detailed information, get your copy of the Western Electric career opportunities booklet from your Placement Officer. Or write College Relations Coordinator, Western Electric Company, Room 6305, 222 Broadway, New York 38, New York. And be sure to arrange for a personal interview when the Bell System recruiting team comes to visit your campus this year—or during your senior year.

**Western Electric** MANUFACTURING AND SUPPLY UNIT OF THE BELL SYSTEM  
 An equal opportunity employer



Principal manufacturing locations in 13 cities • Operating centers in many of these and other cities, plus 36 other, throughout the U. S. • Engineering Research Center, Princeton, New Jersey • Teletype Corporation, Skokie, Illinois; Little Rock, Arkansas • General headquarters, 195 Broadway, New York 7, New York



System contractor: DYNA-SOAR



System integration: MINUTEMAN



Boeing 707 with Boeing-Vertol 107



New Boeing 727 short-range jetliner

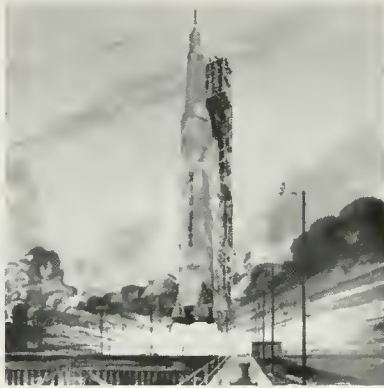

Space booster development: SATURN S-1C



Boeing turbines power helicopters



Boeing KC-135 jet tanker-transport



Boeing Scientific Research Laboratories



HYDROFOIL development, construction

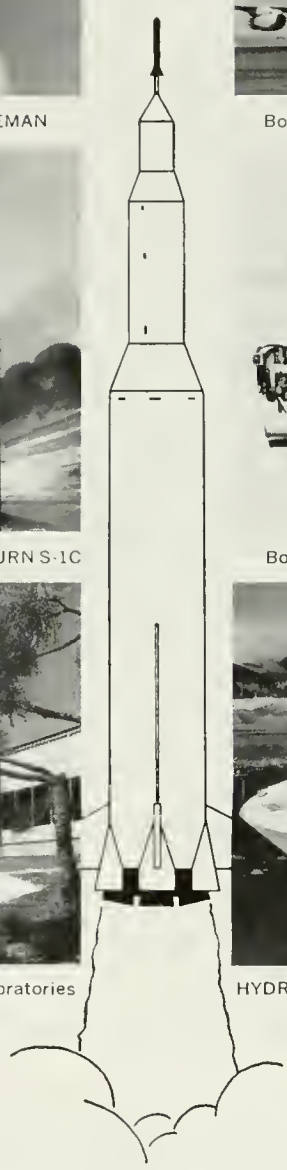

## CAREER BULLETIN FROM BOEING

The wide variety and continuing growth of such Boeing programs as those illustrated on this page offer outstanding career openings to graduates in engineering, scientific and management disciplines. At Boeing you will enjoy the advantages of a professional climate that is conducive to deeply rewarding achievement and rapid advancement. Other

Boeing advantages include up-to-the-minute facilities, a dynamic industry environment and company-paid graduate study programs (Masters and Ph.D.).

*The Boeing representatives will visit your campus soon. They will be happy to provide additional information about expanding Boeing activities in a broad spectrum of fields. The Boeing Company is an equal opportunity employer.*

# **BOEING**





## 250,000 rpm / -452° F

*Miniature turboexpander permits major breakthrough in cryogenics...* Temperatures ranging from -200°F to -452°F are achieved by converting gases such as helium and nitrogen into a liquid state.

When cryogenic liquids circulate over an object, the moving molecules within come virtually to a stop. This abnormal condition makes some metals superconductive and extraordinarily sensitive to any form of electrical energy.

Military and commercial applications include increasing the effectiveness of ground and airborne detection, navigation and communication systems, shrinking the size of computers and solving specialized space cooling problems.

A leader in cryogenic cooling and lightweight turbo-machinery, Garrett-AiResearch is now developing a closed cycle cryogenic system to compress and then expand (boil off) the low temperature gas into its supercold liquid state.

The tiny turbines within the system run on air bearings and eliminate all rubbing surfaces. Much greater system reliability and long life is the result... another major advance by Garrett in the exciting new science of cryogenics.

For information about other interesting projects and the many career opportunities with The Garrett Corporation, write to Mr. C. D. Bradley in Los Angeles.

Garrett is an "equal opportunity" employer.



THE GARRETT CORPORATION • AiResearch Manufacturing Divisions • Los Angeles 9, California • Phoenix, Arizona • other divisions and subsidiaries: Airsupply-Aero Engineering • AiResearch Aviation Service • Garrett Supply • Air Cruisers • AiResearch Industrial • Garrett Manufacturing Limited • Garrett International S. A. • Garrett (Japan) Limited

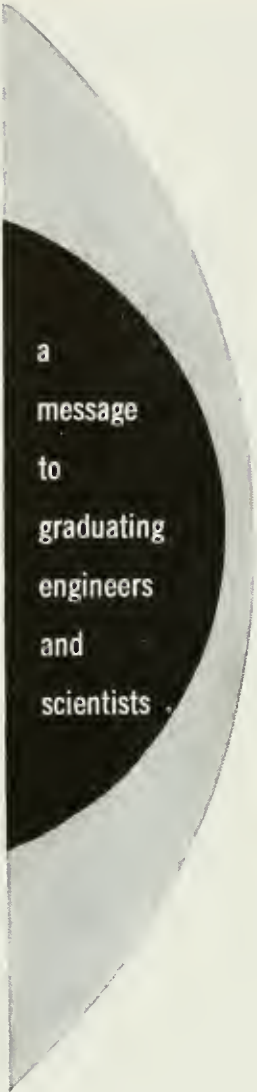

a  
message  
to  
graduating  
engineers  
and  
scientists .

AT PRATT & WHITNEY AIRCRAFT...

**YOUR EYES CAN BE ON THE STAIRS**

SPECIALISTS IN POWER . . . POWER FOR PROPULSION—POWER FOR AUXILIARY SYSTEMS.  
CURRENT UTILIZATIONS INCLUDE AIRCRAFT, MISSILES, SPACE VEHICLES, MARINE AND INDUSTRIAL APPLICATIONS.



# BUT YOUR FEET MUST BE ON THE GROUND

The glamour and excitement of space age programs often obscure a fundamental fact. It is simply that farsightedness must be coupled with sound, practical, down-to-earth engineering if goals are to be attained. This is the philosophy upon which Pratt & Whitney Aircraft's position as a world leader in flight propulsion systems has been built.

Almost four decades of solid engineering achievement at Pratt & Whitney Aircraft can be credited to management's conviction that basic and applied research is essential to healthy progress. In addition to concentrated research and development efforts on advanced gas turbine and rocket engines, new and exciting effects are being explored in every field of aerospace, marine and industrial power application.

The challenge of the future is indicated by current programs. Presently Pratt & Whitney Aircraft is exploring the areas of technical knowledge in *magnetohydrodynamics . . . thermionic and thermo-electric conversions . . . hypersonic propulsion . . . fuel cells and nuclear power.*

If you have interests in common with us, if you look to the future but desire to take a down-to-earth approach to get there, investigate career opportunities at Pratt & Whitney Aircraft.

To help move tomorrow closer to today, we continually seek ambitious young engineers and scientists. Your degree? It can be a B.S., M.S. or Ph.D. in: **MECHANICAL • AERONAUTICAL • ELECTRICAL • CHEMICAL and NUCLEAR ENGINEERING • PHYSICS • CHEMISTRY • METALLURGY • CERAMICS • MATHEMATICS • ENGINEERING SCIENCE or APPLIED MECHANICS.** The field still broadens. The challenge grows greater. And a future of recognition and advancement may be here for you.

---

For further information regarding an engineering career at Pratt & Whitney Aircraft, consult your college placement officer or write to Mr. William L. Stoner, Engineering Department, Pratt & Whitney Aircraft, East Hartford 8, Connecticut.

---

## Pratt & Whitney Aircraft

CONNECTICUT OPERATIONS EAST HARTFORD, CONNECTICUT

FLORIDA OPERATIONS WEST PALM BEACH, FLORIDA

DIVISION OF UNITED AIRCRAFT CORP.  
**U  
A**

An Equal Opportunity Employer

## Miss Joan Bloomberg



If you suddenly find painting, jazz, interior design and horseback riding appealing, it may be because these are Joan's hobbies. However, if none of these rings a bell, maybe you'll develop an interest in Dolphin Candidates or Illio Beauty Finalists (as if you don't already have an interest) when you discover that she has graced both with her charms. Joan has also served on the Model U. N. and Homecoming badge committees and is a bit puzzled as to why she hasn't met more Engineers during her busy days on campus.





## The sky is not your limit

You're looking at an historic first — a 238,857 mile lunar bull's-eye scored by a team of scientists from Raytheon and the Massachusetts Institute of Technology, using a powerful new Raytheon-developed laser light beam. This success typifies the far-ranging variety of advanced projects challenging young engineers and scientists at Raytheon today.

For EE's, math and physics majors — in all the varied fields of engineering and science — Raytheon offers unlimited opportunity for growth and continuous advancement.

Personal career development is encouraged by a wide variety of educational assistance . . . seminars, special courses to meet individual needs and work-study programs leading to advanced degrees from renowned universities are all available.

You may well qualify for one of the exciting, career-building projects underway at Raytheon. Originality, imagination and high technical competence are your tools — the rewards are prompt and appropriate for success.

For detailed information, arrange an on-campus interview through your placement director or write G. W. Lewis, Manager of College Relations, Raytheon Company, Executive Offices, Lexington 73, Mass. An Equal Opportunity Employer.

**Raytheon offers opportunities for BS, MS and Ph.D. levels in**

- Solid State
- Microwave Electronics
- Infrared
- Lasers
- Communication & Data Processing
- Radar
- Missile Systems
- Sonar
- Electron Tube Technology



# EARTH'S LAST FRONTIER

By Wayne Crouch

Man has probed all the continents, and now space explorations are no longer infantile. But in spite of his earthly inquiries and rapid advances in space technology, his efforts to explore the depths of the sea have been only meager.

Exciting science fiction tales have long pictured vehicles capable of escorting man to a new world beneath the sea. Today, however, these adventurous stories are no longer restricted to the world of fantasy. Figure 1 is a photograph of the "Diving Saucer," a deep sea research capsule that has operated successfully in over 65 scientific explorations. This particular capsule operates at depths up to 1000 feet and can stay submerged for four hours.

The significance of this operational model, however, is not in what it has done but rather in its more advanced contribution as a forerunner. Its successor, the "Deepstar," pictured in Figure 2, will be a three-man, self-propelled vehicle capable of operating to a depth

of 12,000 feet. Equipped with remotely controlled mechanical arms for collecting samples and for lighting, the vehicle looks like a fiction writer's dream.

## Deepstar

The Deepstar project is being conducted in cooperation with its designer, Captain Jacques-Yves Cousteau, world famous French undersea pioneer and developer of the Aqua-Lung. The ordnance Division of the Westinghouse Defense Center, Baltimore, Maryland, will build the vehicle as Westinghouse's own laboratory facility to test oceanographic instrumentation, develop new detection techniques, and generally study the marine environment. They will also lease the Deepstar to organizations which need such a special-purpose vehicle for deep sea research and will build similar vehicles for sale or lease on a full-time basis.

The demands for such a vehicle are great. The acceleration of scientific investigation alone makes it inconceivable

that man will not explore the sea. If for no other reason, military pressures will force this exploration. As populations grow, there will also be pressures for ocean exploration for the recovery of minerals (such as petroleum and manganese) and marine life for food. Nearly three-quarters of the earth's surface lies beneath the sea. Unless man can make first-hand observations of this planet's hidden geographical features, he shall never be able to make more than a token attempt to gain the benefits that are surely there.

The seven ton Deepstar will for the first time enable scientists to move about safely and freely at a depth of more than two miles. At this depth the pressure is approximately three tons per square inch. To withstand this pressure the nearly spherical six-foot diameter hull will be made of high grade steel about  $1\frac{1}{4}$  inches thick.

The crew of the vehicle will consist of an observer and a pilot (who will be



Figure 1. The "Diving Saucer," an undersea exploration vehicle, is capable of operating at a depth of 1000 feet and is the forerunner of the more advanced "Deepstar." (Photo courtesy of National Geographic Magazine and Westinghouse College Editorial Service.)





Figure 2. The "Deepstar," a three-man, self-propelled deep sea vehicle, is capable of doing useful work at a depth of 12,000 feet. Equipped with remotely controlled arms for collecting samples and for lighting, the vehicle is designed to provide optimum maneuverability and versatility for research work. (Photo courtesy of Westinghouse College Editorial Service.)

in a prone position) and a co-pilot. The seat in which the co-pilot will operate will be designed to tilt over a range of 90 degrees for the dive.

To make the most of the 24-hour maximum allowable time beneath the surface, the craft will descend and rise in a vertical attitude. Its speed both vertically and across the ocean floor will be approximately  $3\frac{1}{2}$  miles per hour.

Propulsion will be provided by two shaftless propellers which are integral parts of special battery-powered electric motors. Varying the speed of either propeller motor will enable the craft to turn sharply.

In operation, the Deepstar will be neutrally buoyant. Changes in its attitude will be accomplished by means of pumping mercury from one tank to another. Pumping the mercury into a forward tank will cause the vehicle to dive. Reversing the process will point the nose upward. In case of emergency the pilot can ascend rapidly by releasing weights or equipment to give buoyancy.

The submerged range of the vehicle will be about 20 nautical miles. In operation, it will be handled by a "mother ship" that will take it to the point of departure for its dive.

Although the shell and other parts of the vehicle are being produced in Europe, the final assembly will take place in the United States, and if all goes as planned, the Deepstar will be operational in the last quarter of 1963.

#### Future Projections

Although the Deepstar is certainly a remarkable step forward, man will still be limited to a short 24-hour stay. More imaginative fiction writers have solved this problem by putting man in his own underwater "city." Again scientists and engineers are taking these ideas from the

realm of fiction. Figure 3 shows an artist's sketch of how scientists now believe man will soon explore the ocean's floor and tap its vast supply of resources.

The heart of such an operation will be the power plant. The device to the left in the photo is a portrayal of an undersea nuclear reactor that is in its preliminary design stage at the West-

inghouse Astronuclear Laboratory. This unique power plant will have no moving parts and will be able to produce 3000 kilowatts of electricity for life supporting and operational activities in an undersea community. To indicate the size of the proposed power plant, its capacity will be sufficient to handle the normal residential needs of 6000 persons.

The successful operation of the power plant depends upon the thermoelectric phenomenon of the thermocouple, whereby current flows in a closed circuit composed of dissimilar metals when the junctions of the metals are at different temperatures. Thus, with one junction of the thermocouple in the core of the reactor and the other at some distance away, the temperature difference would create a sufficient electric current.

Studies indicate that the reactor could operate on an unattended basis and at full power for 18 months and at reduced power levels for at least six additional months. This indeed seems to be the answer to the biggest problem of an undersea community.

With a little forethought it can be seen that extensive undersea exploration is just in its infancy and will probably flourish in the years to come. The Deepstar and the undersea reactor are only two of many items needed for extensive undersea exploration, but they are the beginning. ◆◆◆



Figure 3. This artist's sketch shows how man could explore "inner space" and tap the vast natural resources on the ocean floor through the use of an advanced power generation system unveiled recently. Heart of the system is an undersea nuclear reactor (left) capable of producing 3000 kilowatts of electricity for life support and operational activities in a two-mile deep undersea community. (Photo courtesy of Westinghouse College Editorial Service.)

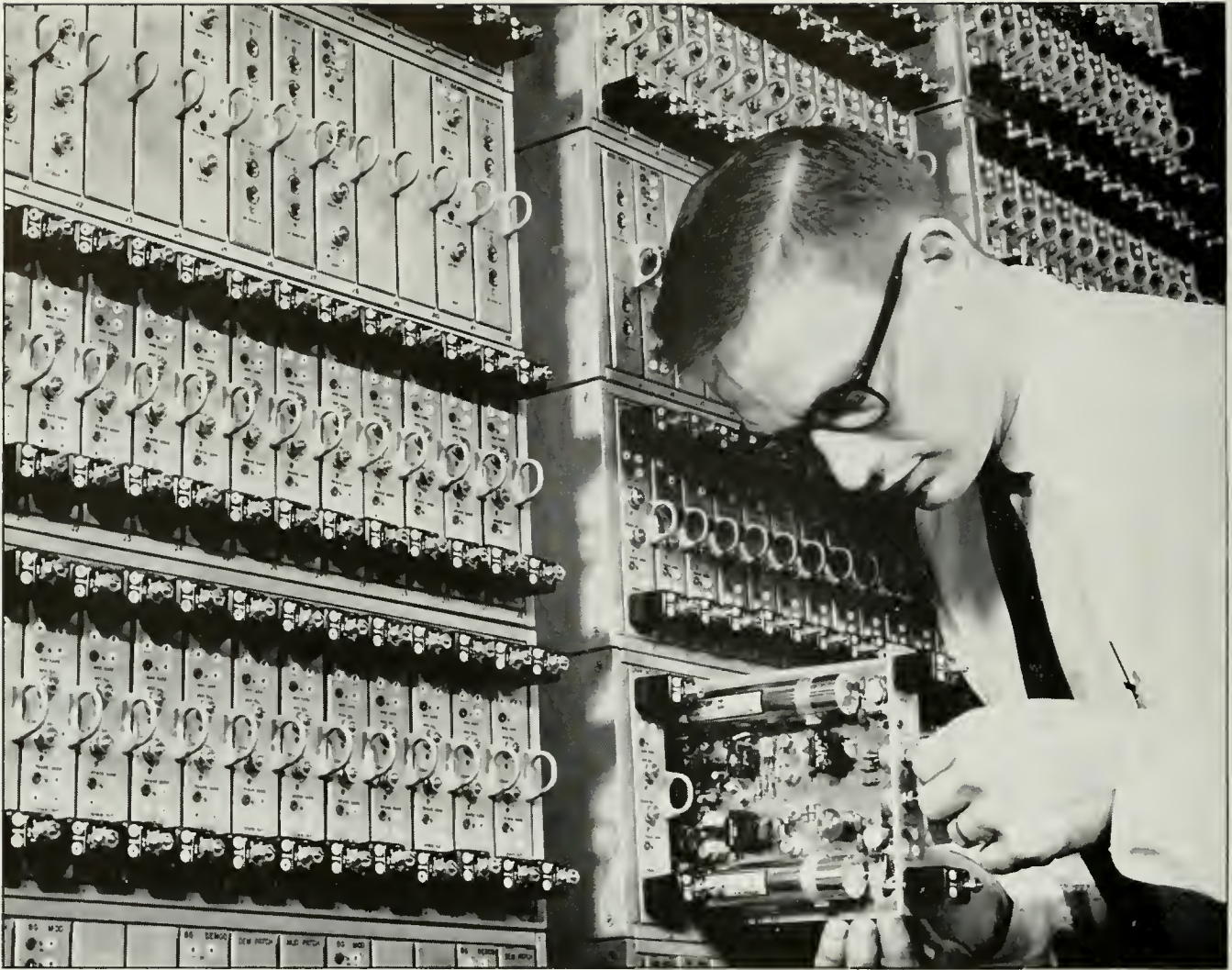

Reasons for building a career at Collins:

## IN MICROWAVE/CARRIER

1. You'll be helping to design the finest equipment built. 2. You'll have the opportunity of working on both military and commercial projects — such as high density multiplex, high speed data communications, integrated communication systems, telemetry and remote control, and transportable systems. And you'll stay right with a project until completion. 3. You'll be with one of the nation's leading growth companies with plants in the locations listed at right and facilities throughout the world.  Contact your placement office, or write to the Collins engineering center nearest you.

Collins has openings for M.E.'s, I.E.'s, E.E.'s and graduate level physicists in design, research and production in these fields:

GROUND COMMUNICATION  
 ANTENNA RESEARCH  
 AVIATION ELECTRONICS  
 DATA SYSTEMS  
 AMATEUR  
 BROADCAST  
 COMPONENTS  
 GENERAL SYSTEMS DESIGN



C. P. Nelson  
 Collins Radio Company  
 Dallas, Texas

L. R. Nuss  
 Collins Radio Company  
 Cedar Rapids, Iowa

E. D. Montano  
 Collins Radio Company  
 Newport Beach, California





# WHY DOW?

Opportunity, in a word.

Chemist or engineer, administrator or scientist of many disciplines, recent graduate or veteran resuming your career—*you* can find opportunity at Dow and you are expected to seek it out.

Opportunity at Dow is for those who create, produce and sell our products, which are: industrial chemicals, plastics, metals, agricultural chemicals, textile fibers, and a growing family of consumer items. We manufacture and sell in 27 locations here, 28 abroad, plus subsidiary and associated companies. It follows, Dow needs

many good people of varying backgrounds. The only limitations are in the people themselves. Promotions are made from within.

Opportunity at Dow is research, going on continually in 50 separate laboratories. Fields include basic research, process development and application research. Present laboratories and plants are being expanded, new ones planned and built. Sales have increased 8 times since World War II. Many of our more than 700 products didn't even exist then.

If you'd like detailed information

about employment opportunities at Dow, see your Placement Director, or write the Technical Employment Manager at any of the locations listed below.

California—Pittsburg • Colorado—Rocky Flats • Illinois—Madison • Indiana—Pitman-Moore Division, Indianapolis • Louisiana—Plaquemine • Massachusetts—Framingham • Michigan—Midland • Ohio—Dobeckmun Company, Cleveland; Dow Industrial Service, Cleveland • Oklahoma—Dowell, Tulsa • Texas—Freeport • Virginia—Williamsburg.

**THE DOW CHEMICAL COMPANY**  
Midland, Michigan

An Equal Opportunity Employer



# NEWS and VIEWS

at the

## University of Illinois

### Music and Monotony

Music, indeed, hath charms. Poets have long told us so. Now a University of Illinois engineer is studying how those charms can be put to work. Stephan Konz, instructor in the Department of Mechanical and Industrial Engineering, is studying the effect of background music on human productivity.

Background music is commonly used in American industry, but the amount of unbiased, impartial, experimental data available on the subject is meager. In the U. of I. study, two different monotonous tasks were investigated with and without background music to see if distinct differences in time consumed and error rate could be found. The two tasks, one "mental" and the other "manual," were performed by a group of college freshmen.

Men and women were equally affected by the background music. The difference in output between the group with background music and the group without it was highly significant. The average improvement during the period when music was played was 17 per cent for the manual task and 18 per cent for the mental task. The error rate (collected only for the mental task) was neither increased nor decreased by the music.

Detailed results of this study, done in cooperation with Professor Josef Cohen of the U. of I. Psychology Department, was given by Mr. Konz in a paper in New York City in November at the Annual Convention of the Human Factors Society. Further details on this study are available from Mr. Konz, 228 Mechanical Engineering Building, University of Illinois, Urbana. (*Reprinted from Engineering Outlook*)

### Electronics for People Not in Electronics

Most chemists, physicists, biologists, and engineers are not electronic experts. This is no more surprising than the fact that most electronics engineers are not experts in chemistry, physics, biology, or in other fields of engineering, but it does

cause more problems. Everyone uses "black boxes," those mysterious testing and recording devices essential to most research, but very few know what to do when these electronic instruments fail to function. Two chemists working at the University of Illinois have found a solution to this problem.

Professor H. V. Malmstadt, a chemist who worked with radar during the war, had the original idea and started working on the problem more than ten years ago. In 1955 he was joined by another U. of I. chemist, Professor C. G. Enke, who in 1959 went to Princeton but has continued to spend his summers at the University of Illinois. They developed a course, equipment, and a book on electronics for people not in electronics, and they tested them in a one-semester course for U. of I. graduate students and in three-week summer courses for men from industry. The course is an integrated system based on laboratory work and presented from the point of view of the user of electronic instruments. Although it will not make him an expert in electronics, the student learns basic rules and facts that will enable him to understand, set up, and service his equipment. He also learns to make alterations or modifications in his black boxes to keep them up to date with his research, as well as how to communicate with the electronics experts he works with from time to time. The book, *Electronics for Scientists*, by Malmstadt and Enke, has just been published by W. A. Benjamin, Inc., New York. Electronic units for the course are produced and sold by the Heath Company, makers of the "Heathkits" long familiar to the electronic and radio fields.

Further information on the over-all program or specific courses at the University of Illinois is available from Prof. H. V. Malmstadt, 306 Noyes Laboratory, University of Illinois, Urbana. Further information on instrumentation may be obtained from the Heath Company, Benton Harbor, Michigan. (*Reprinted from Engineering Outlook*)

### Friction: A Tool for Welding

Friction is a paradox. While even an engineer couldn't live without it, many of his efforts are spent in trying to overcome it. At the University of Illinois, however, friction is being exploited. In the Department of Mechanical and Industrial Engineering the heat generated by friction between two metal specimens is being used to weld the specimens in a bond as strong as any other weld currently in use.

While the phenomenon of friction is not yet completely understood from a scientific standpoint, the process of friction welding has been used on metals in Russia and on plastics in the United States for several years. Because of the lack of research, however, its application has been severely limited.

Friction welding studies at the University of Illinois are being conducted by Mr. M. B. Singer in the Mechanical Engineering Welding Laboratory. Tests have been conducted primarily on low-carbon steels, although a few other materials have been tested. The weld, produced by rotating one specimen while pressing another specimen against it, occurs in four stages: wear in, preheat, constant heat, and upset. The whole process takes less than four seconds for a 1/2-inch-diameter specimen, and can be achieved using a modified lathe. Less power is consumed by this system than by arc or resistance welding, and no special equipment is needed to weld many dissimilar metals. Further, there is no contamination from the heat source, and studies of welding environments are feasible.

One of the current questions being considered in this project concerns the welding of malleable iron, which loses its malleability when subjected to high temperatures for long periods of time. Because of the short welding time the problem of brittleness in malleable iron welds may be overcome by this technique.

The basic properties of materials are also being investigated for this process. For instance, the transition temperature of the base material is being established and subsequent tests on transition temperatures in the weld area will be conducted. Once the principles behind this welding process are more fully understood, the area of application may broaden considerably. In addition, knowledge will be gained of the phenomena of friction, the generation of heat by friction, and the deformation of materials. (*Reprinted from Engineering Outlook*)





## An idea grows from one mind to another.

It may begin with nothing important. Just a word. Or a notion. But as each succeeding mind brings a fresh viewpoint, the idea begins to grow and mature.

If you like working in an atmosphere that breeds ideas, you'll like working at Northrop. Stimulating minds and stimulating projects are all a part of the climate here. We have more than 70 active projects in work, and we're constantly evaluating new lines of inquiry. Projects cover such fields as interplanetary navigation and astro-inertial guidance, aerospace deceleration and landing, man-machine and life support systems for space, automatic checkout and failure prediction systems, laminar flow control techniques and world-wide communications.

For more specific information, see your placement counselor. Or write to Dr. Alexander Weir, Northrop Corporation, Beverly Hills, California, and mention your area of special interest.

**NORTHROP**

AN EQUAL OPPORTUNITY EMPLOYER

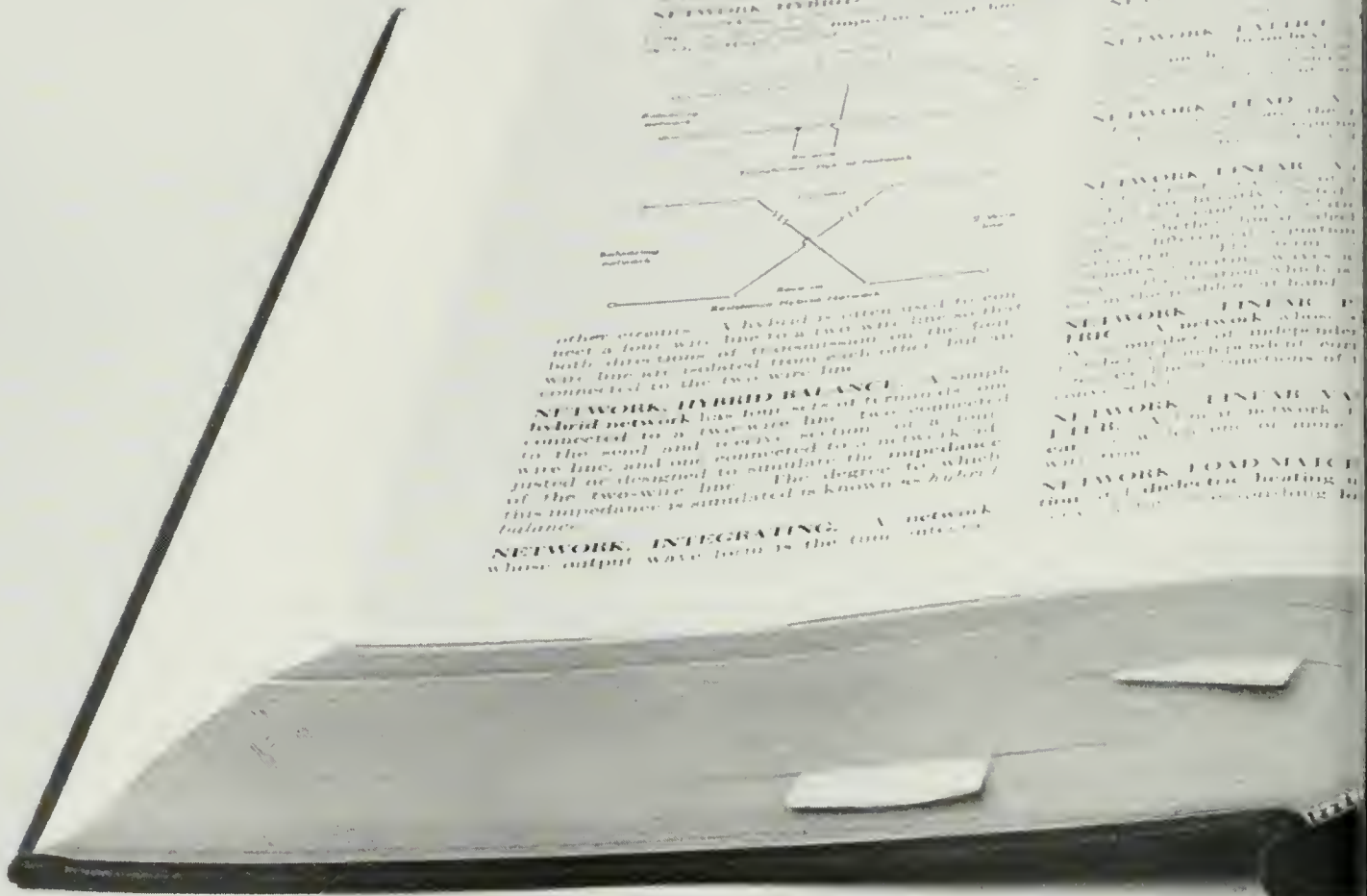

# At IBM® your search for knowledge never ends

At IBM, engineers and scientists are working on some of the most-advanced areas of technology. The study of this new world of data processing technology may lead to significant achievements in research, development, and production—new methods, new systems, and new equipment for extending the reach of man's mind. Seeking basic answers, IBM is embarked on a wide range of research and engineering projects that include the theoretical and practical aspects of: simulation...information-retrieval systems...magnetic memories...chemistry...machine organization...radiation effects...mechanical analysis...and mathematics.

The objectives of IBM scientists and engineers are to synthesize available knowledge, probe new concepts, and develop new techniques. The end results are new ways to broaden the applications and effectiveness of data processing systems for science, defense, government, business, and industry. For example, thin-film circuitry is being developed that will increase the speed, versatility, and economy of future systems. In addition, experimental machines have been devised to read handwritten numbers and many styles and sizes of printing. Other laboratory work involves information retrieval and automatic machine recognition of voice commands.





# THE FUEL CELL

By Wally Schroeter, Ch.E. '64

A new source of electrical and mechanical power will be available for commercial use in the near future. A versatile fuel cell will take its place alongside the internal combustion engine, the electric dynamo, and nuclear facilities. First devised by William Grove in 1839, it is only recently that significant development has taken place. When commercially available, the fuel cell will provide economical, efficient power to operate farm equipment, home power tools, industrial vehicles, and power plants.

Fuel cells have numerous advantages over conventional power sources, the foremost being the absence of moving parts. Also, these devices are theoretically capable of 100% efficiency, although only 45 to 85% values are obtained in practice. These efficiencies compare quite favorably with the average 25 per cent squeezed out of today's electrical and mechanical machinery.

In ordinary power production, a tremendous amount of energy is wasted. Consider the automobile engine. Only the mechanical work of expanding combustion gases is utilized, and engine friction reduces efficiency even more. The bulk of the energy produced is in the form of heat, much of which is conducted away by the cooling system or lost in exhaust. Similarly, generator friction and electrical design limitations sharply reduce the output of our most efficient electrical powerplants.

Having no moving parts, there are no frictional losses in a cell series unit. The conversion of chemical free energy into electrical free energy, theoretically, occurs under ideal thermodynamic conditions, so that 100% conversion seems reasonable. Internal electrical resistance and concentration effects reduce cell efficiency only slightly.

In many respects the fuel cell is similar to the storage battery or dry cell, which are also electro-chemical systems. However, since the fuel cell reaction occurs efficiently and quickly and the gases are cycled rapidly, much current is pro-

duced from a small unit in a short period of time. A series of cells would be able to produce power equivalent to batteries weighing ten times as much.

All fuel cells require both a fuel and an oxidant which are catalyzed at their respective electrodes in reactions involving a loss or gain of electrons. By wiring

the electrodes together and placing them in a suitable electrolyte, a direct current is obtained which may be harnessed for power.

While different cells employ different oxidants and fuels, the common hydrogen-oxygen cell exemplifies the basic operational principles. The cell consists of

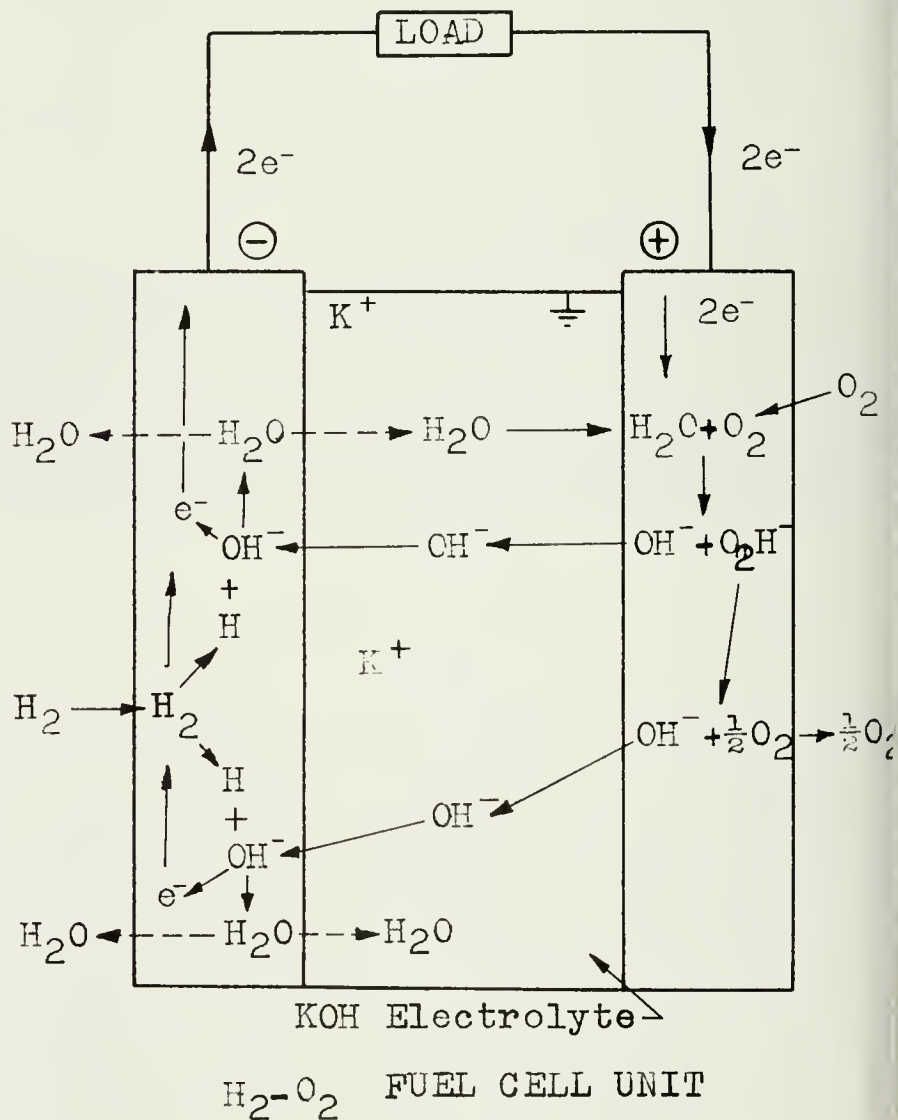



two electrodes (usually porous carbon) which are impregnated with a metal catalyst. Among the metals successfully used are platinum, palladium, and silver.

For catalysis, the cell must be maintained at a temperature suitable for activated absorption to occur. This temperature depends on the specific reactants and cell conditions. To provide this temperature, either some of the fuel or, preferably, any carbonaceous gas products are burned in ordinary combustion.

At the cathode or oxidizing electrode,  $O_2$  (fed under pressure from a supply tank) reacts with water and available electrons to form the unstable perhydroxide ion ( $O_2H^-$ ). This ion readily breaks down into  $OH^-$  and elemental oxygen. The  $OH^-$  serves to replenish the electrolyte which is used up at the anode.

At the anode, hydrogen gas is changed into free hydrogen through catalytic absorption. This elemental free hydrogen subsequently reacts with the  $OH^-$  of the electrolyte (usually 20-50% KOH) to form water plus an electron. By coupling the two electrodes, we can take advantage of the two individual reactions and combine them into a cell with an intracathode current. This flow of electrons is utilized for power purposes. The equations for the cell reactions:

Anode (+)

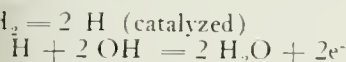

Cathode (-)

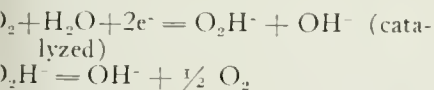

Overall



In spite of its simplicity, the  $H_2-O_2$  cell has presented a few difficulties. While some water is used up in the cathode reaction, even more is produced at the anode, leading to dilution problems. Polarization, or heavy ion concentration at the electrodes, causes corrosion, and therefore limits cell life. The expensive electrode catalysts required increase initial cost. The bulk of the honeycomb of fuel cells is often undesirable for the intended use of the plant. Hydrogen and oxygen themselves are expensive and difficult to handle.

Attempts to solve these problems have led to the design of other types of cells, each of which has its own limitations. Another form of the  $H_2-O_2$  cell, is called the Bacon cell, which was designed to operate with inexpensive nickel electrodes. At 200°C the nickel becomes a suitable reaction catalyst. However, this high temperature (140°C higher

(Continued on Page 38, Col. 2)

## AN OPPORTUNITY TO GROW IN THE HIGHEST PROFESSIONAL WORKING ENVIRONMENT...

MITRE designs and develops systems that enable our military commanders to detect attack and retaliate instantly. Typical systems include Nuclear Detection and Reporting Systems, North American Air Defense Combat Operations Center and Back Up Interceptor Control System. MITRE is also experimenting with techniques for future air traffic control systems.

For the young systems engineer there is no more rewarding work. You associate with the top men in your field. You work in an atmosphere that allows you to extend your capabilities professionally and academically.

At MITRE, men trained in single disciplines are encouraged to grow beyond their original fields of interest. Systems designers learn to work from an increasingly broad base. You may work in such diverse areas as information theory, computer design, display techniques, propagation, or human engineering. You may analyze. You may synthesize. You may deal with systems or components. At the highest levels, you may have to consider political, economic and social factors... as well as the predictable technology. Minimum requirements, B.S., or M.S., or Ph.D. in these disciplines: electronics, physics, and mathematics. MITRE is located in pleasant, suburban Boston. Rewards are competitive. Write, in confidence, to Vice President - Technical Operations, The MITRE Corporation, P.O. Box 208, Dept. UIT 12 Bedford, Mass.

THE  
**MITRE**  
CORPORATION

MITRE, an independent nonprofit corporation, working with — not in competition with — industry, serves as technical advisor to the Air Force Electronic Systems Division, and is chartered to work for such other Government agencies as the Federal Aviation Agency.



There is a critical need in defense and space work for automatic equipment that can go where a man cannot and perform decision functions that up to now only a man could handle. To meet this requirement, a new type of computer has been developed by Douglas. Called an "Optical Decision Filter," it is self-organizing and can recognize and classify three dimensional objects regardless of their size and orientation with respect to its viewing lens. The capabilities demonstrated by this unit give it great potential for application in many defense, space and electronic fields, including the following: photographic analysis; radar signature analysis; ballistic missile decoy discrimination; and starfield (or other pattern) recognition.

## THE NEW GENERATION OF JUDGMENT MACHINES

...A STIMULATING AREA FOR CREATIVE ENGINEERS

and electronic fields, including the following: photographic analysis; radar signature analysis; ballistic missile decoy discrimination; and starfield (or other pattern) recognition.

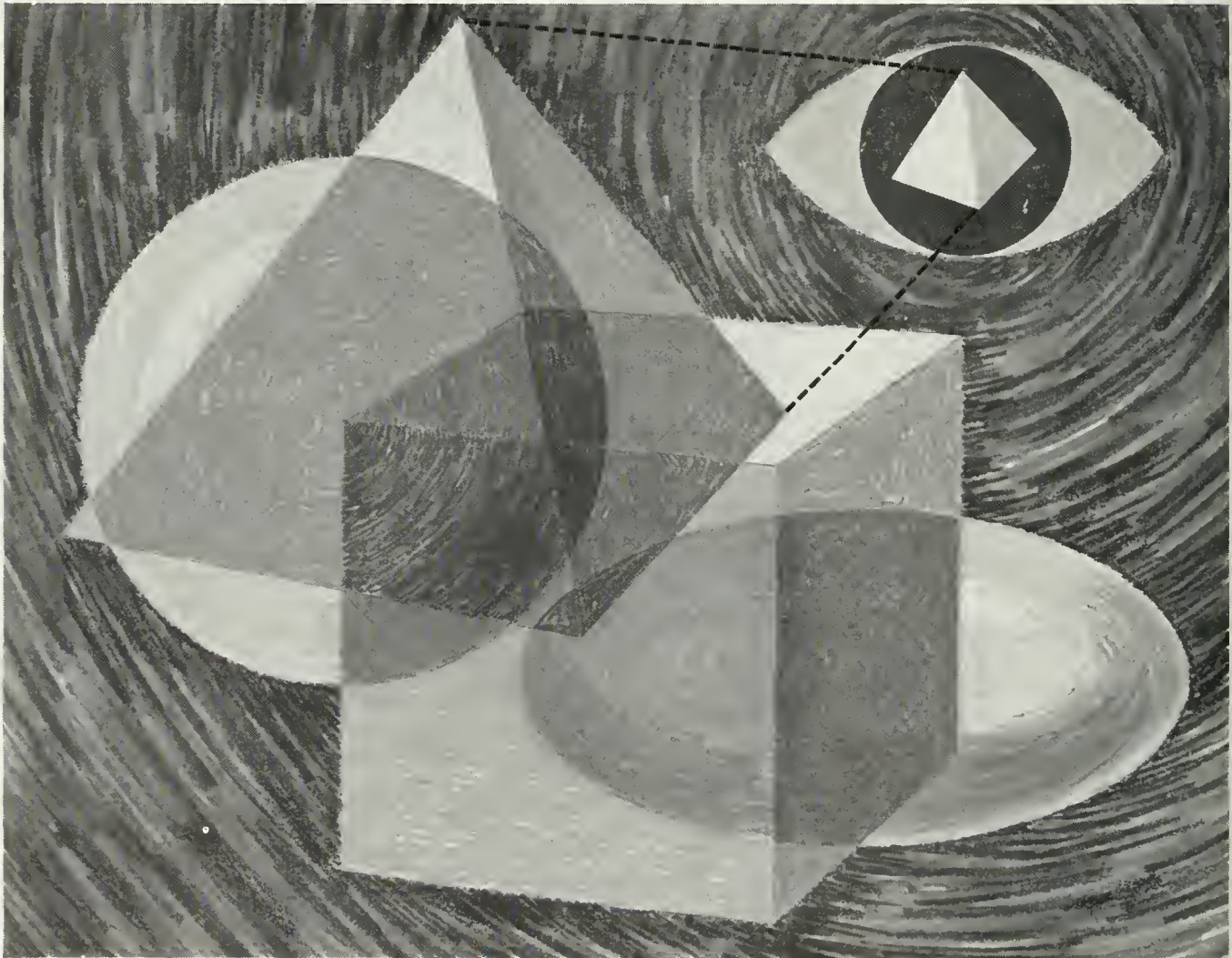

The above is only one of hundreds of interesting assignments at Douglas. If you are seeking a stimulating career with an organization in the thick of the most vital programs of today and tomorrow, we invite you to contact us. Write to Mr. S. A. Amestoy, Douglas Aircraft Company, 3000 Ocean Park Boulevard, Santa Monica, California. Box 600-M. Douglas Aircraft is an equal opportunity employer.

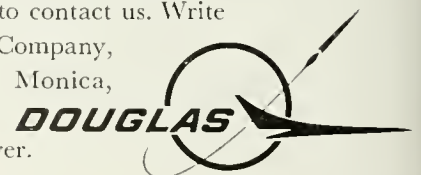





## Your future in engineering is his business

He's a Monsanto Professional Employment representative. He's *your* representative, too . . . your link between campus and company. His knowledge of Monsanto is complete, and he's especially qualified to counsel with you regarding your future.

Ask him about Monsanto's diversity— in geography, activities, products that means ever-expanding opportunity for the young man of exceptional promise. Ask him about Monsanto's research-mindedness, how it helps develop your creativity. Ask this expert in

*futures* about the future Monsanto offers *you* in research, engineering, manufacturing and marketing.

See your Placement Director to arrange an interview when we visit your campus soon. Or write for our new brochure, "You, Your Career and Monsanto," to Professional Employment Manager, Department EM-3, Monsanto Chemical Company, St. Louis 66, Missouri.



®

ALL QUALIFIED APPLICANTS WILL RECEIVE CONSIDERATION WITHOUT REGARD TO RACE, CREED, COLOR OR NATIONAL ORIGIN

# *Assignment: make our cars more rust-resistant*



**Result: '63 Ford-built cars are  
better protected against rust  
than ever before**

To tackle this assignment, Ford Motor Company engineers turned to zinc. Galvanized, or zinc-clad, steel has long been noted for its resistance to corrosion. It presented special problems which had limited its use in automotive applications, however. It was hard to weld, difficult to paint.

Our engineers developed special techniques to solve the welding problem. They found a process which eliminates the crystalline pattern on galvanized steel and produces a surface that will accept a high-quality paint job.

Now zinc can be married to steel and used for vital underbody parts and rocker panels of Ford-built cars. The zinc coating forms a tough barrier to corrosive moisture—and if corrosion attacks, the zinc sacrifices itself through galvanic action, saving the steel.

Other avenues explored in the fight against rust also brought results: special zinc-rich primers to protect key body areas, aluminized and stainless steels to extend muffler life, quality baked-enamel finishes that are more durable (and look better).

Another step forward in total quality—and another example of how Ford Motor Company provides engineering leadership for the American Road.

*Salt-water bath is one of tests  
used to check rust protection  
built into Ford-built cars.*



MOTOR COMPANY

The American Road, Dearborn, Michigan

**WHERE ENGINEERING LEADERSHIP  
BRINGS YOU BETTER-BUILT CARS**



ELECTRONICS  
ENGINEERS  
& PHYSICISTS:

# If space is your future, your career is with Hughes

IN ASTROSPACE  
IN AEROSPACE  
IN TERRASPACE  
IN HYDROSPACE

As far back as 1890, Jules Verne visualized excursion trains to the moon. Today — 73 years later — Hughes offers you the opportunity to play an important part in man's actual conquest of space.

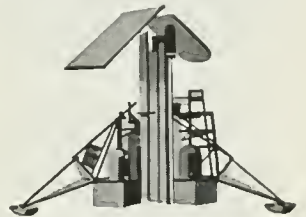

Help us soft-land the SURVEYOR on the moon — or work with us on exciting advanced projects such as:

**TFX(N) ELECTRONICS**

**MMRBM**—Mobile Mid-Range Ballistic Missile  
(Integration, Assembly & Checkout)

**SYNCOM**—Communications satellite

**BAMBI**

**ANTI-MISSILE DEFENSE**

**PLASMA PHYSICS & ION PROPULSION**

**ADVANCED FIXED-ARRAY RADAR SYSTEMS**

**LASER & MASER RESEARCH & DEVELOPMENT**

**NUCLEONICS & MOBOT\* SYSTEMS**

**SOLID STATE MATERIALS & DEVICES**

**DATA PROCESSING & COMMAND-CONTROL**

**B.S., M.S. and Ph.D. Candidates**

Members of our staff will conduct

## CAMPUS INTERVIEWS

**February 28, 1963  
and March 1, 1963**

Find out more about the wide range of activities, educational programs and relocation allowances offered by Hughes. For interview appointment or informational literature consult your College Placement Director. Or write: *College Placement Office, Hughes, P.O. Box 90515, Los Angeles 9, Calif.*

Creating a new world with ELECTRONICS

# HUGHES

HUGHES AIRCRAFT COMPANY  
An equal opportunity employer.

\*Trademark Hughes Aircraft Company

Bettman Archive



# TRIANGLE'S NEW HOUSE



On April 14, 1962, TRIANGLE (U. of I. Engineering Fraternity) defied a forty year incantation and broke ground for an entirely new chapter house. It will be the first newly constructed fraternity house on the U. of I. campus since the 1920's.

It was designed by Champaign-Urbana architects, Simon and Rettberg, after the decision was made to rebuild rather than remodel. By August 1, 1963, the sixty man, \$250,000, seven level house should be completed.

Outstanding features of the new structure include a spacious recreation room located under the sunken living and dining rooms which are at ground level. Two sliding glass panels lead onto the patio from the spacious living room which includes a fire place. Four stories of study rooms and an uppermost dormitory top off the ultramodern structure.

Of utmost interest is the inclusion of an apartment within the house to accommodate TRIANGLE'S first housemother in its history at the U. of I.

## Highway Safety Center . . .

*(Continued from Page 15)*

progressive industries, several per cent of the earnings are devoted to research. . . . Failure to rectify this situation means wasted road dollars—and it can be measured in the great growth in property damage costs, in large numbers of injuries and in traffic fatalities."

Charles F. Carpentier, Illinois Secretary of State, said: "It has been our feeling that the establishment of a traffic safety center at one of the state educational institutions would present opportunities for meaningful and favorable research and study. . . . We would be interested in statistical data in Age-Violation, Age-Accident, Violation-Accident Correlation and similar research data."

## Lab Facilities at University of Illinois

The Center, which is a part of the Engineering College, can take advantage of the traffic engineering lab in Room 404 Civil Engineering Hall. In this lab, concepts of traffic characteristics and control can be explained to those in driver education teaching, traffic engineers and other interested persons.

The lab is filled with reflectorized and non-reflectorized traffic signs and has a traffic signal controller demonstration panel which shows how traffic flow can be handled most efficiently. All traffic signal controllers have been donated by manufacturers except for the master controller which regulates all traffic in the University campus area.

Discovery of better highway planning methods and methods of enforcement

coupled with uniformity in state traffic laws and control devices are the positive steps being taken to reduce the nation's traffic toll for the future.

Through formal education, extension education, research and informational services, the University of Illinois Traffic Safety Center is helping to contribute to that goal. ◆◆◆

## Fuel Cell . . .

*(Continued from Page 33)*

than standard cells) limits the bulky Bacon cell to central power plant usage.

As a replacement for the expensive  $H_2-O_2$  cell, cells consuming plentiful, inexpensive petroleum gases and air have been developed. Indeed, the future of the fuel cell appears to depend on these hydrocarbon cells. One of these types is the molten salt cell. It gets its name from the molten carbonates which serve as the electrolyte. Employing inexpensive metal-oxide electrodes, the cell consumes hydrocarbons and air at a scorching 500 to 800°C. Like the Bacon cell, the molten salt cell will find power plant use, primarily at refinery locations.

Among the other types being developed, the ion-exchange membrane cell stands out. A large portion of the bulk is eliminated by replacing the electrolyte with an ion-exchange resin. This resin in gel form allows for selective transport of ions from one electrode to another. This cell is able to produce from 0.1 to 0.2 kilowatts/pound as compared to half this amount by other cells. However, suitable membranes must be

found for optimum performance and cells must be adapted to economical electrodes and hydrocarbon fuels.

The military is chiefly interested in this lightweight cell for small communications use, such as field radios, radar, and space applications. These small units will also find civilian uses in power packs up to 50 kilowatts. Other types of fuel cells, especially the low temperature cells, will find use in propelling vehicle-size machinery. Since hydrocarbon cells have only water and carbon dioxide as waste products, there are no unburned reactants to contaminate our cities' air as our present automobiles do. Finally, heavyweight, high-temperature cells will be used as central power stations, primarily where fuel is commercially produced. At locations other than refineries, the large fuel cell stations will probably have difficulty competing with nuclear power and present hydroelectric facilities.

It is difficult to predict how soon fuel cell power will be widely available. A great deal depends on the development of efficient, cheap materials. Although at present the initial cost is fairly high (twice the cost of a comparable internal combustion engine), fuel cells are rugged and reliable, delivering economical, maintenance-free performance. ◆◆◆

Sources:

*Status Report of Fuel Cells*, U.S. Dept. of Commerce

*The Fuel Cell*, D. C. McMahon  
*Fuel Cells*, R. Gibbs (Drexel Tech. Jnl.)

*Fuel Cells*, D. Keitz (Rochester Indicator)





## He was a great scientist in his day

This Sumerian was minding our business five thousand years ago.

Like Olin, he specialized in chemicals and metals. He smelted copper and tin to make bronze. He made an iron axle, put it between two wheels, and off he went.

Men have always been trying to find the answers to important problems. Today, Olin is at it, harder than ever.

Our pioneering research in liquid chlorine helped eradicate typhoid and other water-borne diseases.

Our anti-tubercular drug, NYDRAZID®

is a major reason TB deaths decreased 60% in the last eight years.

Olin's ammonium phosphate fertilizer (Ammono-Phos®) makes it possible for farmers to grow more food than ever before.

And to prevent the tremendous waste in food spoilage, we're working on an antibiotic-coated plastic wrapping.

lin

"An Equal Opportunity Employer"

To take a big sting out of life, Olin is developing a high speed cartridge that enables medicine to be injected without the use of hypodermics.

But none of these advances could have been made without our scientists.

Every division of Olin seeks the creative, scientific mind for the answers to the research problems of our day. If this is the kind of work that interests you, call Olin or write to M. H. Jacoby, College Relations Officer, Olin Mathieson Chemical Corporation, 460 Park Avenue, New York 22, N.Y.

# TECHNOQUIPS

A little man was strolling down the street when suddenly he encountered a big guy with a huge bulldog. "Keep your dog away from my dog," shouted the little man. "I warn you!"

The big guy snorted and said: "That's a laugh. What could a little yellow dog like that do to my big bulldog?"

And bang! The fight started. Just when it looked as if the big bulldog would chew up the little yellow dog, the little dog opened its mouth and whammo! . . . That was the end of the big bulldog.

Well, naturally, the big guy was flabbergasted and he screamed at the little fellow: "Say, what kind of a dog do you call that?"

"Well," said the little man, "before I cut off his tail and painted him yellow, he was an alligator."

\* \* \*

Then there's the dachshund who met his end running around a tree.

\* \* \*

He: "Pardon me, but you look like Helen Brown."

She: "Yeah, and I don't look so hot in blue either."

\* \* \*

What they mean when they say:

"See me after class" (It has slipped my mind).

"Pop quiz" (I forgot my lecture notes).

"Thorough quiz" (one covering material not presented in class).

"I will derive" (Formula has slipped my mind).

"Closed book quiz" (Memorize everything, including footnotes).

"Open book quiz" (Oil your slide rule and wind your watch).

"Honor system" (Alternate seats).

"Briefly explain" (Not less than 1000 words).

\* \* \*

A person who claims that absolute zero is impossible, hasn't taken a thermo quiz yet.

\* \* \*

"So your husband is one of the big guns of industry."

"Yes, he's been fired eight times."

\* \* \*

Student's Motto: Keep frowning—and get credit for thinking.

A baseball game being played in a pasture broke up in an uproar during the seventh inning when one of the participants slid into what he thought was third base.

\* \* \*

"I forgot my umbrella."

"When did you miss it, professor?"

"When I started to close it, after the rain stopped."

\* \* \*

He: "You remind me of the ocean."

She: "You mean that I'm wild, romantic, and restless?"

He: "No, you make me sick."

\* \* \*

Answer to a question on a Physics test:

A meter is the distance between two bars in Paris.

\* \* \*

Prof.: "Who is that smoking in the back of the room?"

Engineer: "No one, that's just the fog we're in."

\* \* \*

Mama: "I'm glad to see you sitting so quiet while your father naps."

Junior: "I'm watching his cigarette burn down to his fingers."

\* \* \*

Prof.: "Why are you late?"

Dayhop: "Class started before I got here."

\* \* \*

ME on way to lecture: "I am going with an open mind, a complete lack of prejudice and a cool rational approach to listen to what I am convinced is pure rubbish."

\* \* \*

The car sped off the highway, went through the guard rail, rolled down a cliff, bounced off a tree, and finally shuddered to a stop. A passing motorist who had witnessed the entire accident helped the miraculously unhurt driver out of the wreck.

"Good Lord, mister," he gasped, "are you drunk?"

"Of course," said the man. "What do you think I am a stunt driver?"

\* \* \*

Rush Chairman: "Our fraternity maintains four homes for the feeble minded."

Rushee: "I thought you had more chapters than that."

The Sunday School teacher was showing her pupils a picture of early Christian martyrs in a den of lions. One little boy seemed very disturbed—almost on the verge of tears.

"Gee," he said, "look at that poor lion in the back. He's not getting any."

\* \* \*

A Boston spinster was shocked at the language used by workmen repairing telephone wires near her home, so she wrote to the telephone company. The manager immediately asked the foreman on the job to make a report and here's what the foreman said:

"Spike Williams and me were on this job. I was up on the pole and accidentally let the hot lead fall on Spike—and it went down his neck. Then Spike looked up at me and said: 'Really, Harry, you must be more careful!'"

\* \* \*

A fellow and a girl charged around a corner and bumped smack into each other. They stepped back, apologized and started up again, but they both dodged in the same direction and bumped once more. Again they started up, bumped, and apologized; this time the fellow stopped, raised his hat and gallantly remarked, "Just once more, honey, then I really have to go."

\* \* \*

Professor (pointing to a cigarette on the floor): "Jones, is this yours?"

Jones (pleasantly): "Not at all, sir. You saw it first."

\* \* \*

Two duck hunters were sitting behind their blind, one drinking from a thermos jug of coffee, the other from a jug of whiskey. After some hours of sipping they spotted a lone duck winging through the sky. Taking quick aim, the coffee drinker rose, let fire, and missed. The whiskey drinker rose, let fire, and brought the duck down. His companion, properly amazed, complimented him on the shot. He replied, "Aw, it's nothing. I usually get five or six out of a flock like that."

\* \* \*

Professor Lewellyn Rubin looked toward the next green, waggled his driver confidently, and declared, "That's good for one long drive and a putt." He gave his club a mighty swing, blasted up about two inches of sod, and managed to get the ball about three feet from the tee.

His caddy stepped forward, handed him his putter, and suggested, "Now, for one helluva putt."

\* \* \*

Co-ed: "Where did you learn to kiss like that?"

C.E.: "Siphoning gas."



# Kodak beyond the snapshot...

(random notes)

## At long last, the long last horse



The horseplayers of America have made a contribution to engineering. True horseplayers spend their lives contributing. They contribute by a process based on ordinal digits. Determination of the digits often requires instrumentation. A sound technology has developed to support this instrumentation. The horseplayers gladly support the technology by their contributions. The technology is now old enough to have added the expression "photo finish" to common speech.

A photo-finish negative is projected for the judges less than 25 seconds

after the last horse crosses the finish line. They nearly always wait for the last horse. If the last horse is quite late, it looks longer than the first horse because there is hardly need for it to hurry any more as it passes the finish line. The finish line is the optical conjugate of a narrow slit at the focal plane of the camera. The film moves past the slit at constant speed.

We have just introduced a new KODAK Timing Negative Film for this work. We don't see why the new film should be denied to off-track use. It is a 35mm film with the perforations

omitted and the edge legend KODAK SAFETY FILM reduced in height to .014", all in order to make room for the timing signal and other indicia (some of which have been deleted from the above illustration to protect the privacy of the jockeys). When developed for 10 seconds in the proper hot developer, it yields extraordinary definition at an Exposure Index of about 100. Fixation is extremely rapid. Contrast is readily controlled by the processing parameters. Spectral sensitivity is notably uniform from the ultraviolet to 630m $\mu$ .

## Electric sugar, \$5 per lb.

A mighty industry breaks down the sugar molecule in the interests of conviviality. Use of the sugar molecule as a base for further building is little practiced, except by us. (We do it in the northeast corner of a state which respects the venerable craft that works the other way.)

And what is achieved thereby?

A high dielectric constant, a large increase in the capacitance of an electrical condenser compared with when there is nothing between the plates.

Obviously, the manufacturers of capacitors and of electroluminescent panels have had to be notified. We

find them interested and alert.

We divert a little sucrose from coffee breaks and react it with acrylonitrile, forming a clear, viscous liquid designated *Cyanoethyl Sucrose* in which a statistical 7.3 of the 8 available hydroxyls are replaced by OC<sub>2</sub>H<sub>4</sub>CN groups. At 60 cycles this substance has

a dielectric constant of 38 and competes with other cyanoethylated dielectrics at 11-19 and with chlorinated aromatic hydrocarbons at 4-6. (The dielectric constant of water runs around 80, but water is such watery stuff!)

Other invidious comparisons:

	Cyanoethyl Sucrose	other cyanoethylated dielectrics	chlorinated aromatics
cost per lb.	\$5 (development)	\$12-\$27	15c-25c
dissipation factor (25°C, 60 cycles)	0.010	0.17-2.7	< 0.1
volume resistivity (25°C, ohm-cm)	5 x 10 <sup>11</sup>	3.6 x 10 <sup>9</sup>	> 5 x 10 <sup>12</sup>

## Chemical advice

Virtually every laboratory in this country and many other countries that ever has occasion to work with organic compounds has a green book entitled *Eastman Organic Chemicals List No. 42*. It gives the accepted nomenclature, structural formulas, melting range or boiling range, and prices for convenient quantities of thousands of compounds, many of them in several grades of purity. Perhaps you have a copy.

Get rid of it.

It is out of date. The new one bears the designation *List No. 43*, which seems logical enough. It is BLUE. There is a first-rate chance of acquiring a blue one by asking a division of ours called Distillation Products Industries, Rochester 3, N.Y. If this offer appeals to you at all, we can visualize you in a position some day to do us a favor by buying our chemicals. It is with that same eye to the future that we

try to keep you aware of photographic ways of engineering.

Since past endeavors in these directions have made the goods move well, possibility arises also of becoming *one of us* instead of a customer. For example, successful chemical plants need good men to instrument them for process control. Interested?

**EASTMAN KODAK COMPANY**  
Rochester 4, N.Y.

# Manufacturing Careers Offer Diversity, Challenge and Opportunity

## An Interview with G.E.'s H. B. Miller, Vice President, Manufacturing Services



Halbert B. Miller has managerial responsibility for General Electric's Manufacturing Services. This responsibility includes performing services work for the Company in the areas of manufacturing engineering; manufacturing operations and organization; quality control; personnel development; education, training and communications; materials management; purchasing and systems as well as the Real Estate and Construction Operation. Mr. Miller holds a degree in mechanical engineering and began his General Electric career as a student engineer on the Company's Test Course

For complete information about General Electric's Manufacturing Training Program and for a copy of G.E.'s Annual Report, write to: Personalized Career Planning, General Electric Company, Section 699-06, Schenectady 5, New York.

### Q. Mr. Miller, what do engineers do in manufacturing?

A. Engineers design, build, equip, and operate our General Electric plants throughout the world. In General Electric, this is manufacturing work, and it sub-divides into categories, such as quality control engineering, materials management, shop management, manufacturing engineering, and plant engineering. All of these jobs require technical men for many reasons. First, the complexity of our products is on the increase. Today's devices—involving mechanical, electrical, hydraulic, electronic, chemical, and even atomic components—call for a high degree of technical knowhow. Then there's the progressive trend toward mechanization and automation that demands engineering skills. And finally, the rapid development of new tools and techniques has opened new doors of technical opportunity—electronic data processing, computers, numerically programmed machine tools, automatic processing, feedback control, and a host of others. In short, the requirements of complex products of more exacting quality, of advanced processes and techniques of manufacture, and of industry's need for higher productivity add up to an opportunity and a challenge in which the role of engineers is vital.

### Q. How do opportunities for technical graduates in manufacturing stack up with other areas?

A. Manufacturing holds great promise for the creative technical man with leadership ability. Over 60 percent of the 250,000 men and women in General Electric are in manufacturing. You, as an engineer, will become part of the small technical core that leads this large force, and your opportunity for growth, therefore, is unexcelled. Technical graduates in manufacturing are teamed with those in marketing who assess customer needs; those in research and development who conceive new products; and those in engineering who create new product designs. I sincerely believe that the role of technical graduates of high competence in the manufacturing function is one of the major opportunities for progress in industry.

### Q. What technical disciplines are best suited to a career in manufacturing?

A. We need men with Doctor's, Master's, and Bachelor's degrees in *all* the technical disciplines, including engineering, mathematics, chemistry and physics. We need M.B.A.'s also. General Electric's broad diversification plus the demands of modern manufacturing call for a wide range of first-class technical talent. For one example: outside of the Federal Government, we're the largest user of computers in the United States. Just think of the challenge to mathematicians and business-systems men.

### Q. My school work has emphasized fundamentals. Will General Electric train me in the specifics I need to be effective?

A. Yes, the Manufacturing Training Program is designed to do just that. Seminars which cover the sub-functions of manufacturing will expose you to both the theoretical and practical approaches to operating problems. Each of the succeeding jobs you have will train you further in the important work areas of manufacturing.

### Q. After the Program—what?

A. From that point, your ability and initiative will determine your direction. Graduates of the Manufacturing Training Program have Company-wide opportunities and they continue to advance to positions of greater responsibility.

*Progress Is Our Most Important Product*

GENERAL  ELECTRIC



Ze3Jt

# TECHNOGRAPH SCIENCE AND ENGINEERING WEEKEND MAY 10-11

UNIVERSITY OF ILLINOIS

APR 16 1963

LIBRARY

APR 18 1963

aircraft shell structures  
----CIVIL ENGINEERING----  
automatic control systems  
---power system stability  
radio chemistry-pyrometry  
-THE ILLINOIS TECHNOGRAPH  
--veterinary parasitology

architectural design  
analytical mechanics  
sanitary engineering  
prestressed concrete  
CERAMIC ENGINEERING--  
--LINING ENGINEERING  
ENGINEERING PHYSICS--  
-GENERAL ENGINEERING

quantum mechanics-

PHYSICS welding engineering NAVY R.O.T.C.

CHEMISTRY- ARMY CORPS OF ENGINEERS

PHYSICS theory of structural design

atomic GENERAL ENGINEERING-CHEMISTRY

power microwave theory and techniques human

heat THEORETICAL AND APPLIED MECHANICS

man aircraft shell structures-pyrometry

no automatic control systems-radiology

MECHANICAL AND INDUSTRIAL ENGINEERING

digital computer circuits-surveying

one engineering law-x-ray metallography man

life CHEMICAL ENGINEERING-ARCHITECTURE

light nuclear physics-radio chemistry

atomic mechanical behavior of solids

organic industrial systems analysis

aircraft ELECTRICAL ENGINEERING

surveying- aircraft structures

NAVY ROTC heat transfer

PHYSICS engineering law--

solid state physics- ILLINOIS TECHNOGRAPH

AGRICULTURAL ENGINEERING-heat transfer-gas dynamics  
aerospace and navigational electronics-ARCHITECTURE  
PETROLEUM ENGINEERING-radiology-inorganic chemistry  
PHYSICS-AERONAUTICAL AND ASTRONAUTICAL ENGINEERING-  
rocket propulsion and rocketry-architectural design  
COLLEGE OF VETERINARY MEDICINE-analytical mechanics  
solid state physics-bacteriology and immunology  
antennas and wave propagation-heat transfer  
mechanics of soils and water conservation  
GENERAL ENGINEERING-CERAMIC ENGINEERING  
electric motor application and control  
powder metallurgy-aerothermodynamics-  
cadastral engineering-thermodynamics  
CIVIL ENGINEERING-organic chemistry  
nuclear physics-electrical ceramics  
information theory  
physical chemistry  
aerothermodynamics  
ceramic microscopy  
ELECTRICAL ENGINEERING-gas dynamics  
machine design-architectural design  
JUNIOR ENGINEERING TECHNICAL SOCIETY  
MECHANICAL AND INDUSTRIAL ENGINEERING  
PHYSICS-rocket propulsion and rocketry  
JUNIOR ACADEMY OF SCIENCE-heat transfer  
physical chemistry-PETROLEUM ENGINEERING  
elementary mechanics of deformable bodies,  
man--electric motor application and control  
human factors in engineering for space travel  
aerospace and navigational electronics-ARCHITECTURE  
COLLEGE OF VETERINARY MEDICINE--inorganic chemistry

BIOCHEMISTRY

PHYSICS

ARMY CORPS OF ENGINEERS

GENERAL ENGINEERING-CHEMISTRY

THEORETICAL AND APPLIED MECHANICS

MECHANICAL AND INDUSTRIAL ENGINEERING

JUNIOR ACADEMY OF SCIENCE-JUNIOR ENGINEERING TECHNICAL SOCIETY

METALLURGY ENGINEERING-AIR FORCE ROTC

CHEMICAL ENGINEERING-ARCHITECTURE

ELECTRICAL ENGINEERING

NAVY ROTC

PHYSICS

**EYES MADE FOR DARKNESS** Westinghouse scientists expect that airplane pilots are going to be able to see the ground clearly on a cloudy, moonless night. Astronomers will be able to see vastly beyond the present range of their telescopes, perhaps to the final boundary of the universe, if there is one. Policemen will peer into dark alleys and see through special binoculars. Scientists at Westinghouse are working on the proposition that no matter how dark it looks to us, there is plenty of "light" everywhere; on a black night, in a coal mine, in a sealed room. We just have the wrong kind of eyes to see it all. So they have developed a device that "sees" infrared light which we can sense only as heat...another device that "sees" ultraviolet light, which we can detect only when it gives us sunburn...still another that picks up a single "packet" of light, the smallest amount that can exist, and multiplies it into a visible flash. You can be sure...it's

Westinghouse



holrule



**Editor-in-Chief**

Wayne W. Crouch

**Business Manager**

Gary Daymon

**Production Manager**

Scott Weaver

**Circulation Manager**

Larry Campbell

**Editorial Staff**

Art Beeker  
Thelma McKenzie  
Mike Quinn  
Jim Walters  
Stuart Umpleby

**Business Staff**

Phillip Johnson  
Wayne Worthington

**Production Staff**

Mike Glowaez

**Circulation Staff**

Bob Bittner  
Paul Gihring  
Dick Kolb  
George Muellner

**Photography**

Joe Figueira

**Secretary**

Kathie Liermann

**Advisors**

R. W. Bohl  
P. Bryant  
W. M. Hudson  
E. C. McClintock

# THE ILLINOIS TECHNOGRAPH

Volume 78; Number 6

March, 1963

## Table of Contents

### Special Science and Engineering Weekend Edition

The U in Future .....	George Pusey	4
Chairman of Engineering Open House		
Welcome to Engineering and Science Weekend—1963 .....	Dean H. L. Wakeland	6
The Junior Engineering Technical Society .....		13
Illinois Junior Academy of Science .....		15
Vetevue (College of Veterinary Medicine) .....		17
Aeronautical and Astronautical Engineering .....		20
General Engineering .....		22
Physics .....		23
Army ROTC .....		24
Technoetic .....		27
Women in Engineering .....		30
Naval ROTC .....		33
Civil Engineering .....		35
Agricultural Engineering .....		36
Chemical Engineering .....		37
Electrical Engineering .....		40
Metallurgical Engineering .....		43
Mechanical and Industrial Engineering .....		44
Engineering Mechanics .....		46
Ceramic Engineering .....		47
Architecture .....		50
Technoquips .....		54
Engineering and Science Weekend MAP .....		55
Engineering and Science Weekend TIMETABLE .....		56

**MEMBERS OF ENGINEERING  
COLLEGE MAGAZINES ASSOCIATED**

Chairman: J. Gale Chumley  
Louisiana Polytechnic Institute  
Ruston, Louisiana

Arkansas Engineer, Cincinnati Coopera-  
tive Engineer, City College Vector, Colorado  
Engineer, Cornell Engineer, Denver Engi-  
neer, Drexel Technical Journal, Georgia  
Tech Engineer, Illinois Technograph, Iowa  
Engineer, Iowa Transit, Kansas Engineer,  
Kansas State Engineer, Kentucky Engineer,  
Louisiana State University Engineer, Louisi-  
ana Tech Engineer, Manhattan Engineer,  
Marquette Engineer, Michigan Technic, Min-  
nesota Technologist, Missouri Shanrock, Ne-  
braska Blueprint, New York University  
Quadrangle, North Dakota Engineer, North-  
western Engineer, Notre Dame Technical  
Review, Ohio State Engineer, Oklahoma  
State Engineer, Pittsburgh Skyscraper, Pur-  
due Engineer, RPI Engineer, Rochester In-  
dicator, SC Engineer, Rose Technic, South-  
ern Engineer, Spartan Engineer, Texas  
A & M Engineer, Washington Engineer,  
WSC Technometer, Wayne Engineer, and  
Wisconsin Engineer.

**The Cover: by Bill Small**

**No Comment**

Copyright, 1963, by Illini Publishing Co. Published eight times during the year (Oc-  
tober, November, December, January, February, March, April and May) by the Illini  
Publishing Company. Entered as second class matter, October 30, 1920, at the post  
office at Urbana, Illinois, under the Act of March 3, 1879. Office 215 Engineering  
Hall, Urbana, Illinois. Subscriptions \$1.50 per year. Single copy 25 cents. All rights  
reserved by *The Illinois Technograph*. Publisher's Representative — Littell-Murray-  
Barnhill, Inc., 737 North Michigan Avenue, Chicago 11, Ill., 369 Lexington Ave.,  
New York 17, New York.

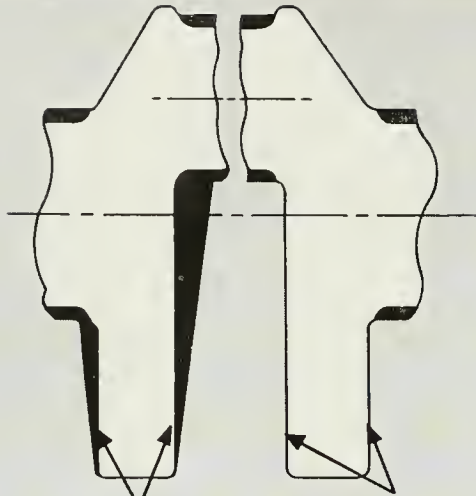

NORMAL CHECKING STOCK

CHECKING STOCK ELIMINATED WITH MALLEABLE

**Eliminate Draft Allowance Metal**

In designing surfaces perpendicular to a parting line, minimum draft angle requirements can be important to finished cost. By changing these automotive crankshafts to high strength pearlitic Malleable iron castings, the draft angle on sides of counterweights was reduced to one-half of one degree. This eliminated all excess stock formerly required in forming . . . and the machining operations to remove it.

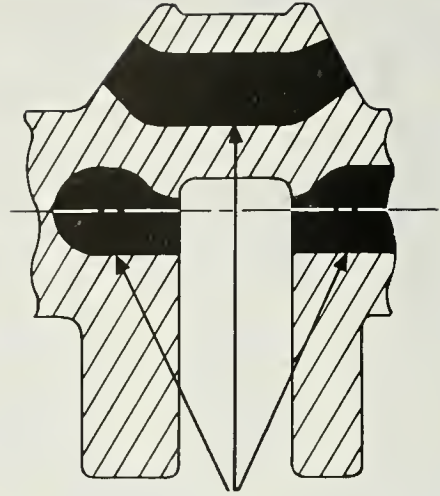

CRANKPIN AND MAIN JOURNAL CORED

**Desired Size Without Excess Weight**

These same crankshafts are excellent examples of how to eliminate metal that serves no function. Crankshaft main journals and crankpins are usually solid because of the method used to form them. Made of pearlitic Malleable iron, these areas can be cored out. This substantially reduces the weight of the crankshaft . . . with no loss in functional strength.

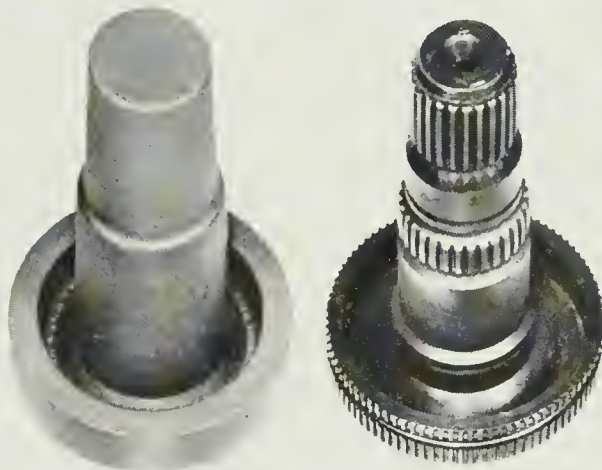

**Put Metal Only Where It Is Needed**

The deep recess at the base of this automotive transmission gear was formerly machined out. Now manufactured of pearlitic Malleable, the recess is created as the part is cast. This eliminates buying unnecessary metal . . . and reduces machining time and cost.



**Start Closer To The Finished Part**

The versatility of design inherent in Malleable castings can save tremendous amounts of money. Final cost of this part was cut 50% by converting to a Malleable casting. A single core provides the sleeve hole, bolt hole, horizontal slot and vertical slot . . . before any machining is done.

# Put High Strength Metal Only Where You Want It With Malleable Castings

Casting is the most direct method of forming metal parts. Of all castable metals, *Malleable iron provides the greatest strength per dollar.* Malleable also combines excellent machinability, ductility, fatigue resistance, design versatility, low start-up cost, and low production cost. Available in tensile strengths up to 120,000 p.s.i., Malleable castings offer the designer a wealth of opportunities to improve quality and trim costs.

Send for this 16 page Malleable Engineering Data File. You will find this informative brochure is an excellent reference piece.

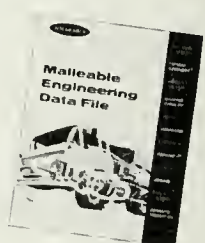

MALLEABLE FOUNDERS SOCIETY • UNION COMMERCE BUILDING • CLEVELAND 14, OHIO



# ITT: AN AMERICAN CORPORATION WITH AN INTERNATIONAL VIEWPOINT

Facts bearing on professional careers at ITT  
answering questions frequently asked us by college seniors

## A MAJOR CONTRIBUTOR TO U. S. DEFENSE

The largest American-owned international enterprise engaged in all aspects of electronic and telecommunication systems, International Telephone and Telegraph Corporation operates both domestic and foreign divisions and subsidiaries. Among its nine principal U.S. engineering/scientific organizations, four are engaged in advanced work for the Armed Forces and NASA. Programs include:

large scale computer-based command/control systems □ global communications systems (line of sight, tropo scatter, lunar bounce, digital, telecommunications) □ ICBM base communications and control systems □ satellite control & communication systems □ engineering support for large scale warning systems □ antisubmarine warfare systems □ electronic countermeasures □ tactical military air navigation systems □ ground support & environmental test systems □ infrared detection & guidance systems □ atomic clocks □ systems management: world-wide, local.

## DEEP IN DIVERSIFIED U. S. COMMERCIAL ENTERPRISES

Prominent among ITT's domestic commercial products is a new, high-speed digital communication system for large industrial firms. ITT in the U. S. also develops and manufactures a vast variety of radio equipments and systems, automatic programmers, teleprinters, telephone equipment, infrared image converters, image storage and intensifier tubes, high resolution scanners, twt's, coaxial cables and other products.

Today, no less than 53 plants and facilities are operated by 16 ITT divisions or subsidiaries in the United States. Their combined income amounts to roughly 40% of the total figure for the world-wide operations of the parent corporation, whose re-

sources stand solidly behind each operation, at home and abroad.

## ITT IN RESEARCH & DEVELOPMENT ENGINEERING

Basic and applied investigations relate to both military and commercial programs. Extensive R & D facilities are provided. To cite one example, ITT's own "Space Communications Research Station," erected in Nutley, N. J., was selected by NASA as one of the ground terminals for the Project Relay experimental satellite communication system.

## A PIONEER IN SYSTEMS ENGINEERING

ITT's long experience in the operation of world-wide communication systems has made it a logical choice for both systems development and systems management contracts awarded by the Armed Forces. Examples are:

Systems development, design and management of the vast SAC global command/control system 465-L □ Coordination and management of the 10 year program to expand and modernize AIR COM, global communications system of the U. S. Air Force.

## GLOBAL PRACTITIONER OF FIELD ENGINEERING

In the Arctic, in the Tropics, on land, afloat, or undersea, ITT skills in on-site engineering for every kind of communication or large scale electronic system have been thoroughly tested. It is equipped to provide complete engineering support anywhere in the free world. This includes installation, operation, maintenance, evaluation and continuous modernization, as assignments may require. ITT's responsibilities in field and applications engineering include: operation, maintenance and testing of Pacific Missile Range facilities for the U. S. Navy □ engineering support, installation and maintenance for a global digital command and control

system for SAC □ tropo scatter communication systems spanning nations in Europe and Asia □ 6,000 miles of advanced radar and communications equipment on DEWLINE.

## UNIQUE INTERNATIONAL RESOURCES FOR PROFESSIONAL ENRICHMENT

ITT foreign affiliates and subsidiaries operate public telephone systems in 19 countries. In addition, more than 12 overseas laboratories have made many significant advances in communications technology. Technical papers and progress reports steadily circulate among R & D people both at home and abroad, and leading ITT scientists and engineers participate in international seminars conducted annually by the company.

## OPPORTUNITIES EXIST FOR RECENT GRADUATES AT THE BS, MS and PhD LEVELS WITH 9 U. S. MEMBERS OF THE ITT CORPORATE FAMILY

ITT Components Division, Clifton, N. J. □ ITT Communication Systems Inc., Paramus, N. J. □ ITT Federal Electric Corporation, Paramus, N. J. □ ITT Federal Laboratories, Nutley, N. J. □ ITT Federal Laboratories, Ft. Wayne, Ind. □ ITT Industrial Laboratories Division, Ft. Wayne, Ind. □ ITT Information Systems Division, Paramus, N. J. □ ITT International Electric Corporation, Paramus, N. J. □ ITT Kellogg Communications Systems Division, Chicago, Ill.

For detailed information about specific positions in your special field of interest, make an appointment through your College Placement Director for an On-Campus Interview or write directly to: Mr. W. A. Moorhead, Mgr., Recruitment and Placement, North America, International Telephone and Telegraph Corporation, 320 Park Avenue, New York 22, N. Y. An Equal Opportunity Employer

# ITT

# The U In Future

By George Pusey, Chairman of Engineering Open House

With your permission, I would like to divide you—the high school students who read this article—into three broad groups.

- 1) **FUTURE UNDECIDED**—Those of you who are still undecided as to your future career.
- 2) **FUTURE ENGINEERS**—Those of you who are definitely interested in becoming engineers.
- 3) **FUTURE NON-ENGINEERS**—Those of you who are not interested in becoming engineers.

If you have a very limited time to read this article, read the first part and then that portion which concerns your groups. All of you are about to embark upon a career which you are likely to follow for the *rest of your life*. Since that will be a long time, you should take a good look at yourself. It may sound odd, but we spend too much time looking at the different careers and not enough time looking at ourselves. Before you can possibly hope to choose a career wisely, you must take a good long look at yourself—your goals and abilities. What do you really want in life?—Really!

When you are sure of what you want out of life and what your abilities are, then, and only then, are you ready to examine different careers. Ask this of each career:

- 1) Does it help me find what I really want in life?
- 2) Do I have the ability required?

You should talk with your parents, high school counselor, teachers, and friends. They have a knowledge of your abilities and a general knowledge of many fields. From talking with them, you should be able to determine the general area in which your talents lie.

When you begin to think about specific careers, you should talk with as many people in these careers as possible. However, do not use their conclusions concerning the field *until you know the reasons behind their conclusions* because their wants and abilities are not yours. To use their information in your conclusions you must know the *WHY* behind their conclusions.

During Engineering Open House, May 10th and 11th, there will be information booths in each of the engineering departments, the Illini Union, and the Assembly Hall. Do not hesitate to come by and ask questions. Here is your chance to talk with many engineering students and faculty and to get their views on engineering.

## Future Undecided

I consider those of you who are **UNDECIDED** to be the most important group. All of us were in your group at one time or another. Certainly I was on the fringe of this group when I first came to Engineering

Open House during my junior year in high school. Engineering Open House is one of the many sources of information which I used in reaching my decision to become an engineer. Before you reach a decision as to what career is best for you, you should go through the reasoning process I outlined above. Know what you want, and what you are capable of doing; then look at the different careers.

Talking with the people in the career is one of the best ways to find out what the career supplies in terms of your wants, and what it requires of you. **BUT DO NOT ASK THEM FOR JUST THE GOOD OR BAD POINTS**, ask them for the reasons **WHY** they feel the way they do. It is not always easy to find the *true* reasons why people feel as they do. You must use some judgment of your own here, but it is essential that you know the reasons behind their conclusions if they are to be of any benefit to you. Also, do not make hasty conclusions. Be sure to talk with many people, and hopefully, a few of them will have goals similar to yours. These people will be of more help than someone with completely different goals.

I hope that you will come to Engineering Open House—for it is here that you will have a chance to talk with many students and faculty in the Colleges of Engineering, Veterinary Medicine, and Architecture. You will find many opinions among the student body, ranging from good to bad. So, again I emphasize the importance of knowing the reason *WHY* the person is saying good things or bad things about engineering, or any other field.

## Future Engineers

Those of you who are **DEFINITELY INTERESTED** in becoming engineers have managed, wisely I hope, to narrow your choice of careers to one field—engineering. But, I hope you realize, and I am sure that most of you do, that engineering is subdivided into many areas. While it is not essential that you know the area in which you want to specialize when you enter engineering college, you should try to set up goals, or areas of study, based on the knowledge which you now have. As you progress with your education, you will need to modify these goals to coincide with a better understanding of yourself—your wants and abilities.

You are probably trying to decide what phase of engineering is best for you. The best way for you to do this is to talk to the students, faculty, and graduates in various fields of engineering. Do not just find out what they think is good or bad about a particular field, find out *WHY*. Only when you know the *why* can you apply their conclusions to the problem facing you.

One of the first opportunities for you to talk with

(Continued on Page 53, Column 1)



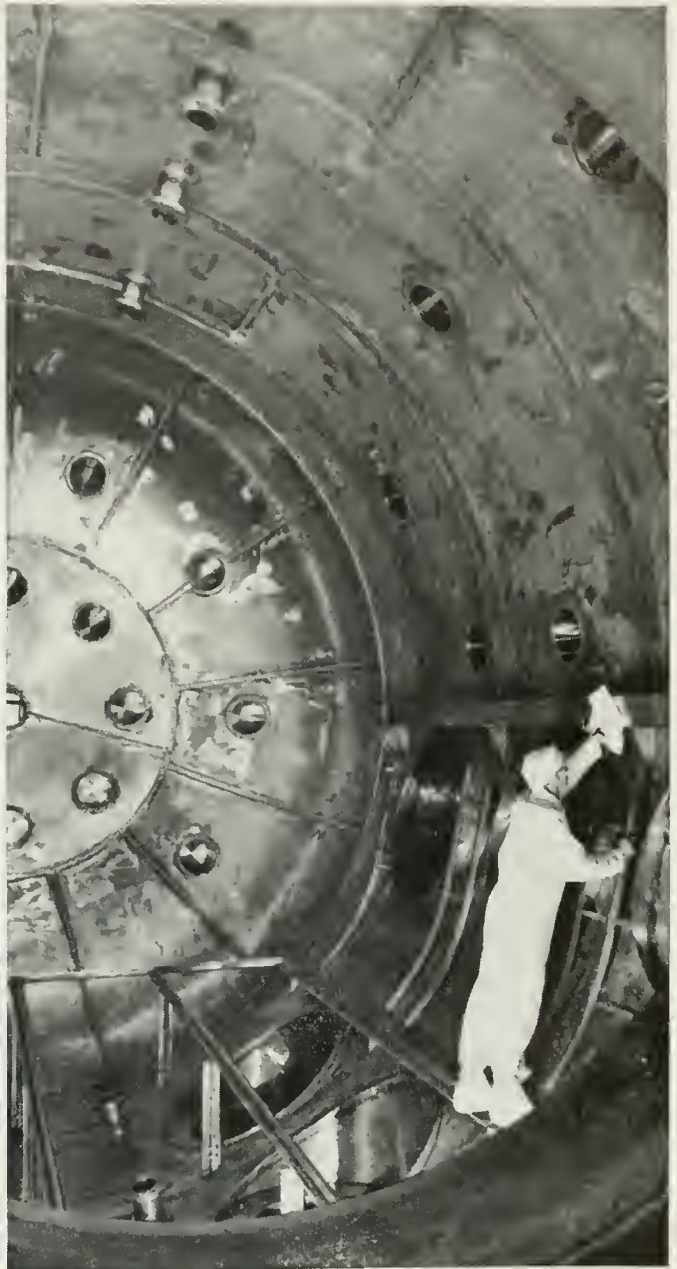

## FROM THE OCEAN'S DEPTHS... TO OUTER SPACE

Striking examples of Bendix research facilities are the huge sonar tank in California and the space chamber in Michigan, among the most completely equipped in the free world. These facilities, designed and financed by Bendix, characterize our continuing advanced product research and development efforts.

College graduates will find a variety of technical challenges. Bendix participates in almost every phase of the space, missile, aviation, electronics, automotive, oceanics and automation fields. We employ top-notch engineers, physicists, and mathematicians at all degree levels.

Bendix operates 32 divisions and subsidiaries in the United States, and 12 subsidiaries and affiliates in Canada and overseas. Our 1950 sales volume was \$210 million. Last year it was over \$750 million.

Look over the materials we have in your school's placement office. Talk to our representative when he's on campus. Meanwhile, if you'd like to have your own copy of our booklet "Build Your Career to Suit Your Talents," write to Dr. A. C. Canfield, Director of University and Scientific Relations, The Bendix Corporation, Fisher Building, Detroit 2, Michigan. An equal opportunity employer.

THERE ARE BENDIX DIVISIONS IN: CALIFORNIA, MISSOURI, IOWA, OHIO, INDIANA, MICHIGAN, PENNSYLVANIA, NEW YORK, NEW JERSEY, MARYLAND.

WHERE IDEAS  
UNLOCK  
THE FUTURE



FISHER BUILDING, DETROIT 2, MICH

# Welcome . . .

to

## Science and Engineering Weekend 1963

by Dean H. L. Wakeland

This year's student-sponsored "Engineering Open House" is uniquely different from those in the past. University of Illinois engineering students have combined this event with the Illinois Junior Academy of Science State Fair, the 11th Annual Junior Engineering Technical Society Exposition and Conference for the Central U. S. Division, and the Veterinary Medicine Open House to make the weekend of May 10 and 11 an enlightening one for high school students and visitors interested in science or engineering. In addition, the new circular Assembly Hall, a true engineering marvel, will be open for inspection.

For years, engineering students at the University of Illinois have set aside one weekend each spring to open the doors of the Engineering College to acquaint prospective students and friends with the facilities and educational programs of the college. At this event visitors can talk with faculty members and students and see some of the laboratory facilities in use. Exhibits and demonstrations are presented to acquaint the public and prospective students with engineering education and opportunities as well as with the types of work engineers perform.

The students and staff in the College of Engineering welcome YOU to YOUR university. The facilities, programs, and opportunities here are YOURS—the citizens of Illinois. The College of Engineering is truly one of the greatest in the nation—but only because the citizens of Illinois have been willing to generously support it.

As you walk through the various laboratories, you may be more impressed by the bigness of the facilities—the Mark II Triga Nuclear Reactor, the 3 million pound test machine, electron microscopes, IBM 1401 and 7090 computer facilities, the betatron and cyclotrons—yet the simpler, more readily understood exhibits probably give a better representation of the basic physical laws used in engineering. Exhibits of stream flow, basic electronic circuits, gears and mechanisms, roof frames, and models of atomic structures of materials depict more simply and clearly some of the physical and chemical principles upon which the larger or more mysterious exhibits are built. Try to look beyond the outward results of exhibits and ask why they function as they do. Do not let size or complexity distract you from the basic principles being displayed.

If you leave feeling that the field of engineering is too big and broad to easily visualize, then you will also realize the unlimited opportunities in engineering. Presently, there is a tremendous need for engineers in all fields, but, unfortunately, engineering freshman enrollments have been dropping during the past few years. Few fields have the opportunity, challenge, interest, and rewards that engineering offers. Nearly 200,000 unfilled engineering positions currently exist, and salaries are at an all-time high. The reason most engineers selected this vocation, however, is the continually changing challenge. Each day they must stretch themselves to solve new problems and continually ask, "How can I do this?", "What materials shall I use?", "Is there some other

solution that may be more economical or efficient?", "How can I obtain this part quickly?", or "Will I be able to meet the time schedule?".

As you tour our campus, a few facts about the College of Engineering are not self-evident. For instance, last year the College of Engineering graduated the second largest number of engineering bachelors degrees of any school in the nation, the third largest number of masters degrees, and the second largest number of doctors degrees. No other single institution conferred more total degrees in engineering than Illinois last year. In addition, Illinois had the second largest research budget. This indicates that the program is well balanced, and during last year no other school was consistently in the top five in each of the categories, as was Illinois.

Each year approximately 700 students receive a bachelors degree in engineering and about 1,000 freshmen enter this field at Urbana each fall. A great majority of the classes in engineering are still taught with 24 students per section or less. Instruction in every major engineering field is offered, and most minor fields are also included.

Since there is a great need for capable young men and women to enter the engineering field, we are hopeful that many Engineering Open House visitors will have their interest sparked and become more aware of engineering and the engineer. Parents, high school teachers, and prospective students can obtain more information about the College of Engineering by coming to 106 or 103 Civil Engineering Hall. ◆◆◆



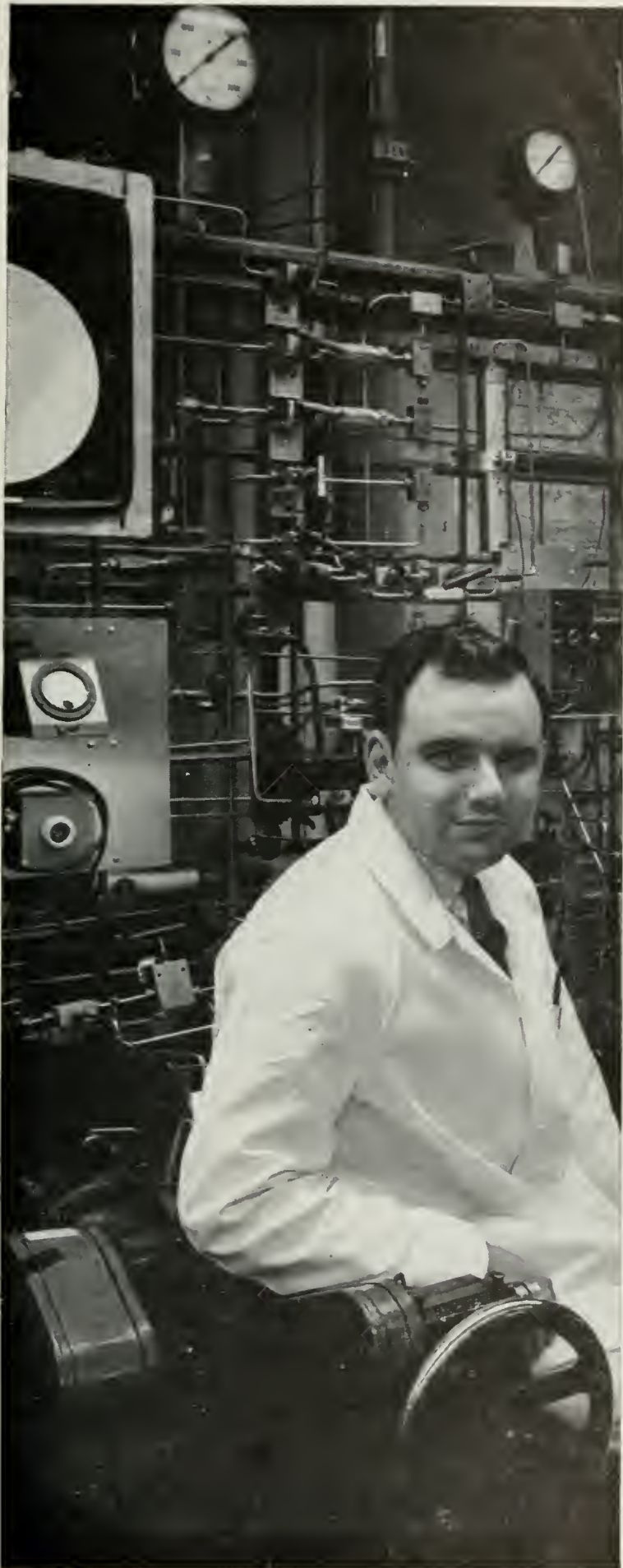

## *Variety: the spice of life at American Oil*

*by Jim Koller*

"When I was first interviewed by American Oil representatives I was told I'd be given a free hand in guiding a wide variety of projects. This promise has certainly been kept!"

Jim Koller, 25 years old, came to American Oil right out of the University of Wisconsin where he earned his Bachelor of Science degree in Chemical Engineering. An Evans Scholar at Wisconsin, Jim describes his job at American Oil this way: "I work on basic chemical engineering problems, specializing in reactor design and process development problems. Before a process can go commercial, it must be tested in pilot plants. That's where I come in." Jim wants to stay in the technical research area, and plans to enroll in the Illinois Institute of Technology night school for courses in advanced mathematics.

The fact that many gifted and earnest young men like Jim Koller are finding challenging careers at American Oil could have special meaning for you. American Oil offers a wide range of new research opportunities for: Chemists—analytical, electrochemical, inorganic, physical, polymer, organic, and agricultural; Engineers—chemical, mechanical, metallurgical, and plastics; Masters in Business Administration with an engineering (preferably chemical) or science background; Mathematicians; Physicists.

For complete information about interesting careers in the Research and Development Department, write: D. G. Schroeter, American Oil Company, P.O. Box 431, Whiting, Indiana.

---

IN ADDITION TO FAR-REACHING PROGRAMS INVOLVING FUELS, LUBRICANTS AND PETROCHEMICALS, AMERICAN OIL AND ITS AFFILIATE, AMOCO CHEMICALS, ARE ENGAGED IN SUCH DIVERSIFIED RESEARCH AND DEVELOPMENT PROJECTS AS:

New and unusual polymers and plastics • Organic ions under electron impact • Radiation-induced reactions • Physicochemical nature of catalysts • Fuel cells • Novel separations by gas chromatography • Application of computers to complex technical problems • Synthesis and potential applications for aromatic acids • Combustion phenomena • Solid propellants for use with missiles • Design and economics: new uses for present products, new products, new processes • Corrosion mechanisms • Development of new types of surface coatings.



**STANDARD OIL DIVISION  
AMERICAN OIL COMPANY**

*Opportunities are better than  
ever at Bethlehem Steel!*

## What has Bethlehem Steel been doing lately?

- ... designing and building nuclear-powered naval vessels
- ... moved into new research laboratories unexcelled by those of any industry
- ... building new mills, the last word in steelmaking technology
- ... fabricating and erecting steelwork for the nation's great structures

Bethlehem Steel is one of the largest steel producers... one of the largest industrial corporations... one of the largest structural steel fabricating and erecting operations... and *the* largest privately owned shipbuilding and ship repair organization.

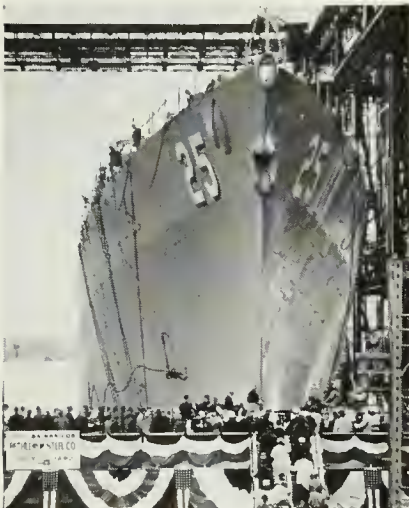

But mere size is only a part of the story. Throughout Bethlehem Steel the key word is *new*. New facilities, new products, new ways of doing things—exciting new developments providing rewarding careers for able and energetic young men who join this organization through the Loop Course.

### What is the Loop Course?

The Loop Course is our program designed specifically to train men for management careers. New loop-

ers report to our general headquarters in Bethlehem, Pa., early in July. They attend a basic course of five weeks, including talks and discussions by top Company officials, educational films, and daily plant visits (this circuit, or "loop" through a steel plant, is what gave the course its name). The Loop Course is *not* a probationary period. After completion of the basic course, every looper receives his first assignment, whereupon he goes through another, more specialized, training course before beginning actual on-the-job training.

### Loopers are Career Men

We select qualified men for the Loop Course on the basis of their potential for careers in management. In most years we enroll over a hundred graduating seniors, most



of them engineers. There are about 2,000 loopers on the job today at Bethlehem, at all levels of management, in our General Offices, and in all of our diverse operations, which include steel and manufacturing plants, research, sales, mining, fabricated steel construction, and shipbuilding.

### Read Our Booklet

The eligibility requirements for the Loop Course, as well as how it operates, are more fully covered in our booklet, "Careers with Bethlehem Steel and the Loop Course." Copies are available in most college placement offices, or may be obtained by writing to Manager of Personnel, Bethlehem Steel Company, Bethlehem, Pa.

*An equal opportunity employer*



# BETHLEHEM STEEL







## Instant portable power... any time, any place

In this battery-sparked new world of portable convenience, hand tools are driven by their own rechargeable batteries . . . toys perform their tricks by remote control . . . a hearing aid with its button-size power cell can be slipped into the ear . . . cordless radios and television sets are lively companions in the home or outdoors . . . missiles and satellites are guided through the vastness of space. ► Developments like these have brought more than 350 types of EVEREADY batteries into use today, 73 years after Union Carbide produced the first commercial dry cell. Ever-longer service life and smaller size with power to spare are opening the way for batteries, such as the new alkaline cells, to serve hundreds of new uses. ► For the future, along with their research in batteries, the people of Union Carbide are working on new and unusual power systems, including fuel cells. And this is only one of the many fields in which they are active in meeting the growing needs of tomorrow's world.

A HAND IN THINGS TO COME

LOOK for these other famous Union Carbide consumer products—

LINDE Stars, PRESTONE anti-freeze and car care products, "6-12" Insect Repellent, DYNEL textile fibers.  
Union Carbide Corporation, 270 Park Avenue, New York 17, N. Y. In Canada: Union Carbide Canada Limited, Toronto.

**UNION  
CARBIDE**



**PROJECT MANAGEMENT**  
R. J. Hayes  
Indiana Tech—BSME—1956



**SALES ENGINEERING**  
R. J. Hummer  
University of Toledo—BSEE—1961



**DEVELOPMENT ENGINEERING**  
J. H. Trumble  
University of Dayton—BSEE—1960

## There's a challenging, rewarding future for



*C.W. Ludvigsen, Manager—Systems Sales, tells how creative graduates contribute to pioneering, automation developments.*

Now, to meet the pressing challenge of industrial automation, Cutler-Hammer has formed a number of automation project teams.

These teams combine the technical and manufacturing talents of versatile, seasoned specialists and you, creative-minded engineering and business graduates.

Their primary job: to make sure that a customer's automation investment pays an adequate return.

### How they work

How do they meet this challenge? By working with customer engineers and consultants to isolate cost problems in industrial process,

manufacturing, and warehousing operations. Then, by applying their individual talents and creative ingenuity to develop, design, build, and install practical automation systems that will insure good return on investment.

### Where they work

Automation teams work together in a Milwaukee-based, modern, 500,000 square foot plant specifically designed to house every activity involved in the evolution of a complex system... in a creative climate that is conducive to imaginative planning and pioneering development.

### What they have done already

This approach has paid off! The industry has barely scratched the surface of the automation potential. Our credentials already are impressive.

Profit-making automation systems such as... a bundle-handling system for 30 major newspaper rooms... a package-handling system for a prominent publisher U.S. Post Office mail-handling systems in 14 major cities... package handling systems... more than a score of major steel-mill finishing lines... automatic warehouse control systems... and auto body handling systems are just a few examples of our creative planning and developmental skill at work.

### What is your opportunity?

What are the advantages to



## OMATION PROBLEM SOLVERS



**MANUFACTURING ENGINEERING**  
H. Menzel  
Michigan Tech—BSME—1955



**CONTROL ENGINEERING**  
L. Gall  
University of Illinois—BSEE—1960



**ANALYTICAL ACCOUNTING**  
A. E. Morgan  
University of Wisconsin—BA—1960

# u, too, on a Cutler-Hammer automation team

young, creative-minded grad-  
Short range, it's an exceptional  
tunity—if you spark to the  
nge of finding new solutions  
ugh manufacturing problems.  
usual opportunity to get  
y involved in problem solving  
from the start!

ng range, being a key member  
Cutler-Hammer automation  
is an excellent way to get the  
sified experience so essential  
ntinuing career development  
ature advancement. It's particu-  
ly beneficial if you have  
ations to move into manage-  
ranks.

### What to know more?

today to T. B. Jochem, Cutler-  
ner, Milwaukee, Wisconsin,  
mplete information. And, plan  
et with our representative  
he visits your campus soon.

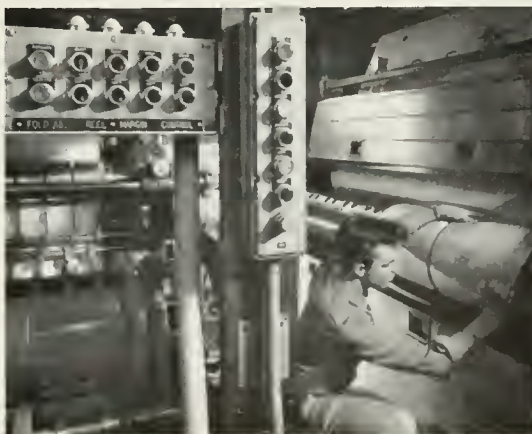

**A CUTLER-HAMMER AUTO-  
MATION TEAM** helped the  
**WALL STREET JOURNAL** solve  
major production and distribu-  
tion problems of a national  
newspaper by designing and  
building control systems for  
two new, highly automated  
printing plants. Controls per-  
mit the world's fastest presses  
to produce newspapers at the  
rate of 70,000 per hour.

*Cutler-Hammer is an equal  
opportunity employer.*

WHAT'S NEW? ASK...

# CUTLER-HAMMER

Cutler-Hammer Inc., Milwaukee, Wisconsin • Divisions: AIL, Thayer Scale • Subsidiaries: Uni-Bus, Inc.; Cutler  
Hammer International, C.A. • Associates: Cutler Hammer Canada, Ltd.; Cutler-Hammer Mexicana, S.A.



The undeniable thrill of  
successful accomplishment  
can be yours as a member  
of the aggressive,  
visionary  
team now forging  
a new future at **DELCO**

solid state electronics ●



Make an appointment to talk with our  
interviewer when he visits your campus,  
or for additional information write:  
MR. C. D. LONGSHORE, Supervisor  
—Salaried Employment:



DELCO RADIO DIVISION OF GENERAL MOTORS

KOKOMO, INDIANA

*An equal opportunity employer*



# The Junior Engineering Technical Society

Freshman Student: I want to enroll in Engineering.

Dean of Engineering: What kind of Engineering?

Freshman Student: Just Engineering. Isn't Engineering all-inclusive? I never knew there were many kinds.

The above conversation is typical on college campuses during registration. There are nearly 100 definite fields of specialization within the engineering discipline. A recent article in the *Journal of Engineering Education* mentions, "The largest number of different degrees currently offered are found in engineering fields, with almost 350."

We could continue indefinitely listing the various questions constantly being asked about engineering. Two questions are sufficient, however: What is engineering, and who is qualified to become an engineer?

The above basic questions, among others, are those the Junior Engineering Technical Society, better known as JETS, is trying to help high school students answer.

JETS has been called the 4-H of engineering. It is international in scope, and its national headquarters are located in the United Engineering Center in New York City—the headquarters of most of the engineering societies. State and area coordinating offices are distributed geographically throughout the United States at leading engineering colleges. Local chapters are organized at high schools by students interested in learning more about engineering or applied science. Each JETS chapter is sponsored by a teacher and is provided with one or more engineering advisors who are practicing engineers in the community.

The chapters meet as frequently as they desire and organize themselves to suit their local situation. Chapters undertake projects, discussions, and activities that are connected with engineering and applied science. Their engineering advisors help them with information, materials, and general counsel in the different areas of individual or group interest.

This year JETS has started an aptitude search open to all students between the 7th and 12th grades. A 2½-hour

battery of tests is given to the participants. The results of these tests are scientifically evaluated and returned to the students. Those participating in the search are followed until graduation with guidance material based on their aptitude. A fee of \$2.00 per student is charged which covers the tests plus the follow-up guidance. Awards are given to those making notable scores on the tests.

Early in the fall leadership conferences are held at state or area levels. These usually take place on a weekend and may last from one to two days.

During the spring, state or area expositions are held throughout the country, followed by a national exposition. At the expositions both papers and projects are presented by the chapter members who have participated in the JETS program.

In Illinois during the summer, two-week orientation programs in engineering and applied science are offered under the sponsorship of JETS and the faculties and staff of the universities hosting the programs. These two-week programs bring the students to a college campus and familiarize them with the requirements of college life and the different aspects of engineering as seen at the college level.

JETS is a fully rounded guidance and orientation program for students who might be interested in engineering or applied science. The program does not force school authorities or teachers to spend undue extra time working with the chapter. The major portion of the work is carried on by the engineering advisors. They are able to bring to the members the professional experience of a practicing engineer.

JETS is fully recognized in Illinois by the Illinois High School Association and at the national level by leading educational associations, and scientific and professional engineering societies.

JETS is entirely supported by contributions from industry and professionally organizations. Each chapter pays an annual fee of \$5.00 to enroll in the program. This fee entitles the chapter to all the services of the national, state, and area offices. There is no individual member fee. The \$5.00 annual fee covers the entire membership of a chapter.

In our advancing technological and scientific world it is difficult for high

school students, teachers, and parents to be aware of the work performed by engineers. A high school student who is considering professional study should have the opportunity, while in high school, to become acquainted with the different professions and the opportunities open to him after graduation. Only by close investigation of all careers can a student make a sensible choice of profession. JETS is a vehicle by which any high school student may evaluate his aptitudes, abilities, and interests for the engineering profession.

Our complicated educational structure makes it desirable that a student, early in his high school education, decide upon the profession he intends to pursue. College entrance requirements vary considerably and a student cannot wait until his last semester to properly prepare for admission into the curriculum of his choice. The decision must be made at least by the end of the junior year. JETS is a good way for high school students to determine whether or not they wish to enter engineering. *Students who are undecided should follow the high school courses necessary to gain admittance to a school of engineering.* This sequence will usually allow them to enter any college.

On May 10-11, JETS will hold the Central Division of the 11th Annual National JETS Engineering Exposition and Conference on the University of Illinois campus. The Second Annual State of Illinois JETS Exposition will also be held at this time as part of the National Exposition. The meeting will bring together participants from states in the central area of the country. The Illini Union Ballroom will be the exhibit area and the exhibits will be open to the public both on Friday, May 10, from 9:00 a.m. to 9:00 p.m. and Saturday, May 11, from 9:00 a.m. to 5:00 p.m. Saturday morning from 9:00 to 12:00 in Room 314, Altgeld Hall. JETS papers will be presented by chapter members. The public is cordially invited to attend both the paper sessions, as well as to visit the exhibits. On Saturday, May 11, at noon in the Illini Room of the Illini Union, and awards luncheon will be held. Complimentary tickets will be given to representatives of the different JETS chapters who are attending the exposition. ◆◆◆



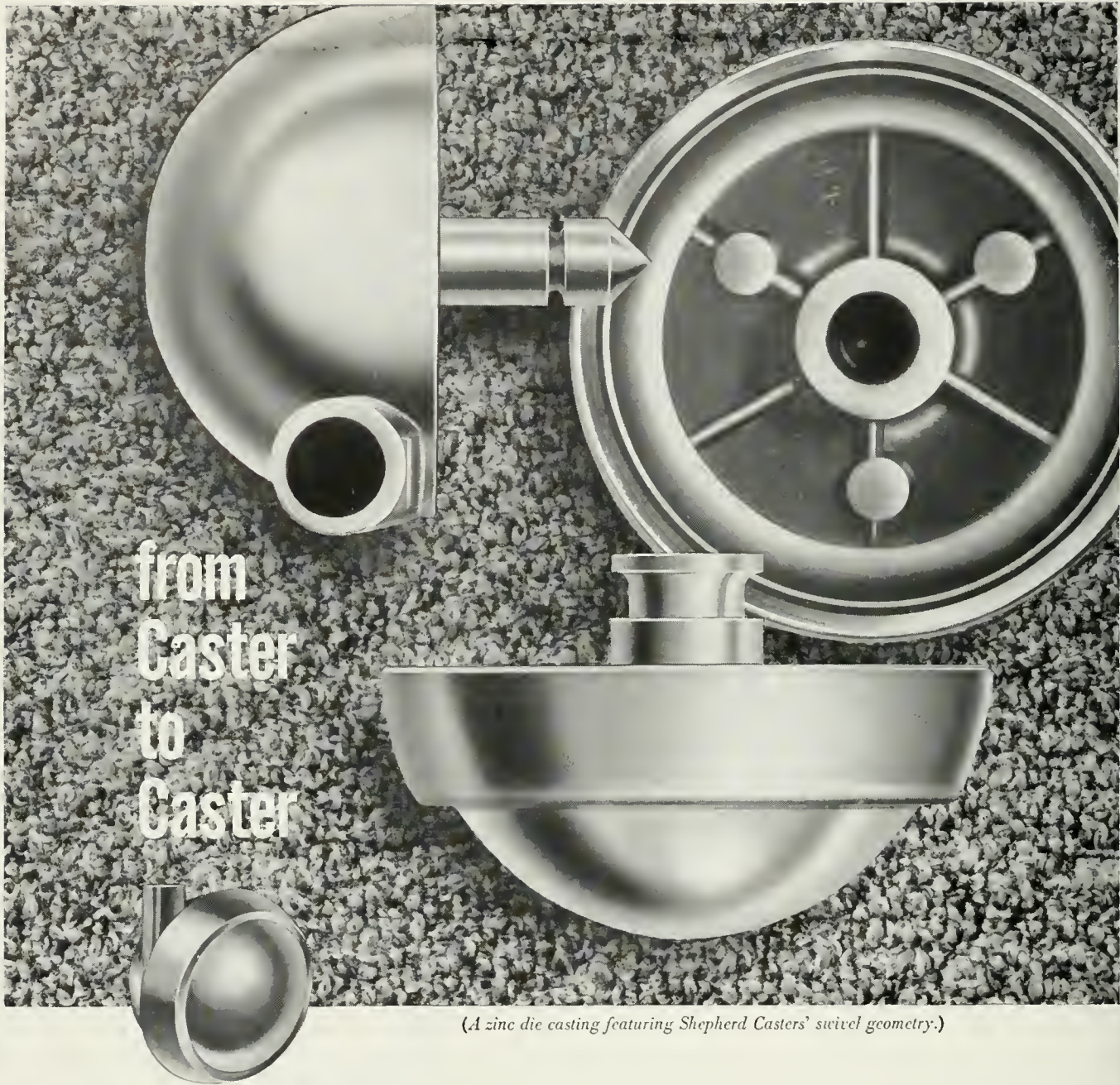

from  
Caster  
to  
Caster

*(A zinc die casting featuring Shepherd Casters' swivel geometry.)*

*Mr. Engineer—How else would you make it?  
Are you interested in the search for practical solutions to  
ever changing problems? The die casting process has infinite  
technical requirements, and the limitations are only those of  
the mind which accepts the challenge of further development.*

**NEW PRODUCTS CORPORATION**  
BENTON HARBOR MICHIGAN



# Illinois Junior Academy of Science

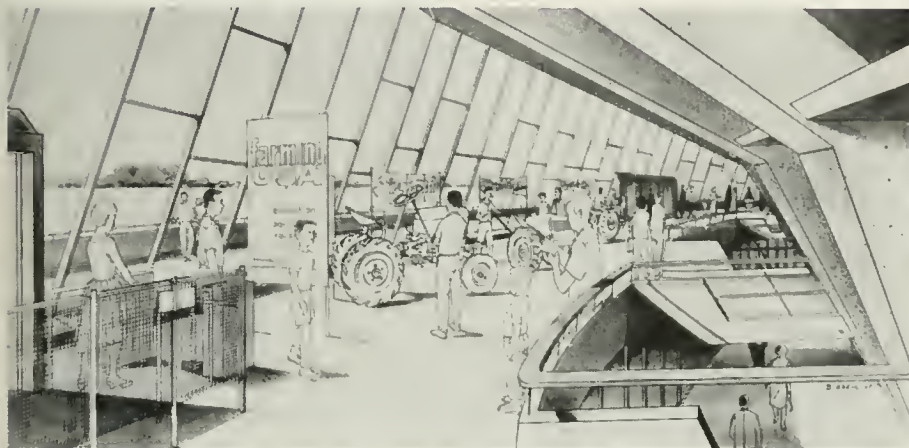

Figure 1. An artist's conception of the concourse of the Assembly Hall with an exhibition in progress. The Junior Academy will use this space for their exposition this year.

The Illinois Junior Academy of Science, largest and oldest Junior Academy in the United States, is an organization of junior and senior high school students interested in research in all areas of science and mathematics.

Since 1927 the Junior Academy, under the auspices of the Illinois State Academy of Science, has grown from one meagerly attended yearly meeting to eleven yearly meetings. The state is divided geographically into ten districts and the best student investigations from a school's individual science fair are sent to the district exposition in April. After a day of further judging the best projects are awarded first place and these students are eligible to enter the State Science Exposition. Last year over 1500 students vied for top honors in the state exposition. These top students were selected from over 40,000 students participating in the program in the state of Illinois.

The Illinois Junior Academy of Science State Exposition is a two day activity. The first day is devoted to the exposition of the projects while the second day is primarily for the presentation of student research papers.

On Friday, May 10th, beginning at

seven in the morning and lasting until ten in the evening the some fifteen hundred students exhibiting projects, will be very busy setting up their projects, adjusting and explaining their masterpieces.

Approximately 500 judges, representing university scientists, industrial scientists, science teachers and various lay people begin carefully evaluating the student investigations and talking with the students. Each judging team of three people carefully judge from five to eight projects and spend from ten to thirty minutes with each student. Along with quizzing the student about his apparatus and his knowledge of the subject, the judges also carefully scrutinize the student's research paper, offering comments and assistance. Awards which the judges must decide upon for each project consist of First, Second and Third, and the top award, Outstanding. The rating of outstanding is a very special citation. Only 5% of all of the state entries receive this coveted award. The work for an outstanding exhibit represents definite genius and would be in the opinion of the judges comparable to the work of a Master's Thesis of a college student.

When the judges are finished talking with a student, the student still finds himself busy explaining his exhibit to other interested high school students, university students and the general public. During the rest of the afternoon, the students will have ample time to attend the Engineering Open House along with the other very worthwhile open houses and special campus activities.

Promptly at 4:30 the students must return to the Exposition Hall to receive their awards from the various judges and Junior Academy Officers. Between this time and 6:30 the students must remove their projects and get ready for the Annual Junior Academy of Science Banquet.

The banquet, planned by the student officers of the junior academy is held in the banquet hall of the Illini Union and lasts for two hours. Among special guests recognized are the state winners of the Westinghouse Science Talent Search, the Outstanding Project winners and the officers of the junior academy. Following the meal, a brief lecture will be given by one of the men of the university science faculty. Following the banquet the students are free to attend the various special campus activities planned for them.

The students who stay over until Saturday, usually the largest percentage, spend their morning attending the Paper Session Program of the Junior Academy of Science.

The paper session is separate from the project section. The student sends his particular research paper to the paper session chairman in mid-March. The chairman then sends the paper on to a head judge in the various sciences and mathematics. The paper is then carefully scrutinized by the head judge and his committee of scientists and teachers. The best five projects are invited to be read at the Saturday session. During the readings of these papers, judging is again made, with the best papers judged First Place. These winners are then honored at a special Honors Assembly at 11:30 Saturday morning. The winners receive token monetary awards and are invited to have their paper published in the *Transactions*, the official publication of the State Academy of Science. This program officially ends the Junior Academy of Science State Exposition. The students are free in the afternoon to attend the various open houses.

All readers of the *Technograph* are cordially invited to visit the State Science Exposition of the Illinois Junior Academy of Science, during the Engineering Open House. We feel sure you will be impressed with the fine science talent present in our junior and senior high school students. ◆◆◆

# READOUT OF YOUR PROFESSIONAL POTENTIAL AT SYLVANIA ELECTRONIC SYSTEMS

Virtually all of the advanced technical disciplines involved in large electronic system complexes are embraced in the R&D programs at the 17-laboratory organization at Sylvania Electronic Systems. Study the chart below to see if *your* chosen field of endeavor is listed.

	APPLIED RESEARCH LABORATORY Waltham, Massachusetts Central Research Facility for Entire Division	EASTERN OPERATION Laboratories at Waltham, Massachusetts and Needham, Massachusetts	CENTRAL OPERATION Williamsville, New York Advanced Communications Systems Laboratories	WESTERN OPERATION Mountain View, California Electronic Defense Lab; Reconnaissance Systems Lab
Advanced Systems Planning	●	●		
Advanced Phased Array Antenna Systems		●	●	
Aerospace Systems Research & Development	●	●	●	●
Airborne Instrumentation	●		●	●
Antenna Research & Development		●	●	●
Command & Control Systems	●	●		
Communication Techniques Research & Systems Development	●	●	●	
Data Processing & Display Systems R&D	●	●		●
ECM & ECCM Techniques	●		●	●
Electronic Tactical Warfare Systems				●
Information Handling Systems	●	●		
Intelligence & Reconnaissance Systems			●	●
IR Sensor Techniques	●	●		●
Microwave Research & Development	●	●		
Microelectronics Research		●	●	
Navigation Techniques	●		●	●
Operations Research	●	●		●
Optical Data Sensing Systems		●		●
Radio & Radar Research	●	●	●	
Reliability		●	●	●
Speech & Character Recognition Research	●			
Solid State Devices	●		●	
Simulator Systems	●	●	●	
Systems Integration Techniques	●	●		
UHF-VHF Circuit & Component Design		●	●	●

Now consider the opportunity for personal growth offered by our parallel advancement plan. Here, you can pursue your career as an Engineering Specialist, choose Technical Management or go into Program/Project Management. In all cases, the rewards and advancement opportunities are *equal*.

Sylvania Electronic Systems is a major division of Sylvania Electric Products Inc., and provides over-all systems engineering and management on major government projects for the parent company, General Telephone & Electronics.

For further information, contact your College Placement Director or write to Mr. Robert T. Morton.



40 Sylvan Road - Waltham 54, Massachusetts

AN EQUAL OPPORTUNITY EMPLOYER U. S. Citizenship required





Figure 1. Using the latest techniques in surgical equipment, U. of I. veterinarians perform abdominal surgery on an aging dog. Small animal surgery will be performed at Vetevue.

Vetevue, a revue of Veterinary Medicine in the Space Age, will be a special feature of the Science and Engineering Weekend at the University of Illinois, May 10 and 11. Live surgery, exhibits and demonstrations will highlight the revue.

Surgery will be performed on large and small animals. Goats will be used for rumenotomies—surgical operations often necessary in "Hardware Disease." This condition, most common in dairy cattle, results when animals swallow nails, wires and other objects present in their feed. No harm is done unless the objects penetrate the stomach wall. Rumenotomies are commonly performed on all ruminants—cattle, sheep and goats.

Horses will be used to demonstrate an anesthetic agent, sucostrin. When injected into the horse's vein, sucostrin causes the skeletal muscles to relax completely. Within seconds, the horse "goes to sleep," allowing approximately eight minutes of surgical anesthesia. This drug is used commonly in practice as an aid in performing castrations, minor operations and mouth examinations. After 10 to 15 minutes, the animal completely recovers from the anesthetic.

Small animal surgical operations will be performed on dog patients of the University of Illinois Small Animal Clinic. Possible small animal surgery includes the delivery of pups via Caesarian section, the routine "spay," tumor removal and the repair of bone fractures.

Chickens will be used to demonstrate use of radio-active isotopes in diagnosing disease. The isotope of calcium will be fed to hens, absorbed by their bodies

# Vetevue

A Review of Veterinary Medicine  
in the Space Age

and eventually incorporated into the egg shells. Vetevue will be able to use geiger counters to find the "hot" eggs after they have been dispersed among normal eggs.

The electron microscope will also be shown. This machine is used to view viruses and study bacteria in much greater detail than that allowed by light microscopes. Magnifications of 50,000 to 100,000 times are possible with the electron microscope.

A sheep will serve as a subject for the polygraph or "lie detector." Changes in blood pressure, respirations, and the pattern of heartbeat are graphically recorded simultaneously.

Other demonstrations include the making of microscopic slides, giving medicine to dogs and cats, the mothering effect brought about by injecting a female hormone into a rooster and the role clinical laboratory procedures play in diagnosing disease. Each person present will have the opportunity of hearing his own heartbeat amplified over a loudspeaker.

Another highlight of Vetevue will be a film, *The Gentle Doctor*, which traces the co-existence of man and beast

through the centuries and also the role of the veterinarian during the past 4,000 years in caring for and protecting domestic animals.

Care of the aged or geriatric dog will be featured in one of the small animal displays. Splints on parakeets will also be a feature.

X-rays of calves destined to be dwarfs will be shown and compared with X-rays of normal calves. A display of radiography equipment will also be exhibited.

Vetevue will be able to observe tissue cells growing inside a test tube. This is known as tissue culture, a method for producing vaccines against virus diseases. The importance and care of germ free animals will be another feature of the exhibits.

Displays on cancer, tuberculosis, and other diseases as prevalent in animals as in people will be presented. Other displays involve the detection of poisons in animal tissues, the prominence of parasitic conditions in animals, the care of laboratory animals, and the zoonoses—diseases transmitted between people and animals. Other presentations will emphasize anatomy and physiology. ♦♦♦



Figure 2. Dr. H. J. Hardenbrook, U. of I. veterinarian, displays nails, wires and other hardware surgically removed from the goat held by Ray Smith, senior in veterinary medicine. Hardware disease results when animals swallow metal objects which accidentally get into their feed. The surgery necessary to remove hardware will be performed at Vetevue.



*Assignment: find new ways  
to reduce vehicle weight*

**Action: Now under Army test, a Ford-designed glass filament torsion bar that's lighter, stronger, more flexible than steel**

"Looks like you've got something there," the Army Tank Command said in effect to Ford Motor Company engineers. "Let's do a feasibility study on tracklaying military vehicles."

The story begins in 1957 when Ford engineers conceived the idea of a plastic-bonded glass filament torsion bar for vehicle suspension systems. It was a revolutionary departure from the use of solid steel. It promised dramatic weight savings in battle tanks, in personnel carriers and other military vehicles. For example, as much as 1,000 pounds in medium tanks.

Compared to steel, the tubular-shaped glass filament composition has greater energy storage potential—is stronger and more flexible under heavy load. It may well prove to be the automobile suspension material of tomorrow . . . cars suspended on glass!

Another example of engineering leadership at Ford and new ideas for the American Road.



MOTOR COMPANY  
The American Road, Dearborn, Michigan

**WHERE ENGINEERING LEADERSHIP  
BRINGS YOU BETTER-BUILT CARS**



*. . . for the technical minded*

THE ILLINOIS

# TECHNOGRAPH

**\$150**

Per Year  
By Subscription

---

25c Per Copy  
on The Newsstands

**8 Issues A Year**

October Through May

---

*"A self-supporting student publication, published to be of interest to engineering and scientifically minded students."*

---

**MAIL SUBSCRIPTIONS TO:**

The Illinois TECHNOGRAPH  
215 Civil Engineering Hall  
Urbana, Illinois

# Aeronautical and Astronautical Engineering

The Department of Aeronautical and Astronautical Engineering studies many technical areas which are important to the fields of aeronautical engineering and astronautics. In addition, teaching and research in the areas of missiles and space flight have long been an important element. Aeronautical engineering has greatly broadened its scope during the last century, and it is expected to expand even faster in the future. In its programs in education and research, the department plans to be as progressive as its name suggests. Although the scope and course emphases change periodically, investigations are normally undertaken in each of the major subdivisions of aerodynamics—propulsion, structures and vehicle dynamics. Current efforts are concerned with supersonic and hypersonic aerodynamics, rarefied gas dynamics, plasma generation, magnetogas dynamics, aeroelasticity, structural behavior at elevated temperatures, and vehicle dynamics and propulsion. Plans are underway to expand the study of low-speed aerodynamics and ground effect vehicles. Engineering Open House will show visitors some of the principles of these space age engineering projects and their applications.

As part of its contribution to advances in the aerospace field, the department offers many courses and engages in high-speed flight research. When a vehicle exceeds the speed of sound it forms shock waves in the air that drastically hinder its performance. The department's shock tubes which will be on exhibition are used for instruction and research on fundamental problems associated with the shock wave phenomena. One of these tubes can propel shock waves through a gas at velocities greater than 20 times the speed of sound, thus making it a valuable instrument in the area of supersonic flight, missiles and space exploration. Supersonic wind tunnels are also used for high-speed

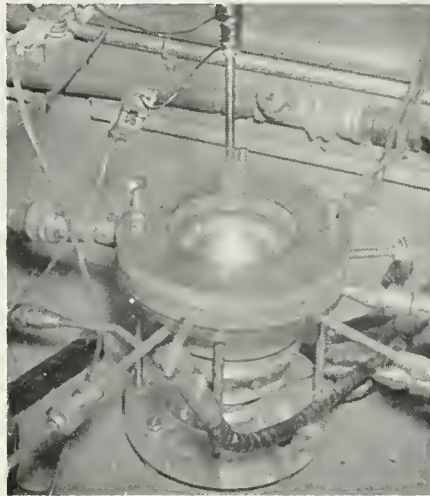

Figure 1. The thermal electric rocket motor produces a plasma consisting of an electrically neutral conglomeration of ions, electrons and neutral atoms with temperatures up to 30,000 degrees F.

aerodynamics investigations.

Manned aircraft studies are by no means left out of the instructional and research programs. Consideration is being given to a wide range of aircraft varying from vertical take-off and landing airplanes to high-altitude hypersonic-speed craft. A small wind tunnel will be used to show how an airplane derives its lift from a pressure difference between the upper and lower wing surfaces.

Advances in propulsion systems have enabled engineers to design vehicles capable of exceeding the speed required to escape from the earth. All modern propulsion systems are included in the educational programs. At the low end of the speed spectrum the department investigates ground effect vehicles—machines that move close to the ground on

“cushions of air.” (See Feb. TECH). The vehicle performance spectrum illustrated by these examples indicates the breadth of interests of the Aeronautical and Astronautical Engineering Department, and also shows that higher and faster is not the only direction aerospace technology is moving.

When the biplane was the champion of the air the primary problem of aircraft structural engineers was to design structures with sufficient strength to withstand relatively small flight and landing loads. Loss of material strength due to high temperatures, for example, was not a problem. Today, however, engineers must design light weight structures which will be subjected to high temperature and dynamic loadings which greatly complicate their problems. Examples of aero-structures testing will be exhibited showing how engineers tackle certain types of practical problems. Also, the basic design principles of a filament wound solid fuel rocket motor case will be explained.

Space flight will be well represented at Engineering Open House. A working model of a thermal electric (plasma) rocket motor will be on display. The plasma produced is an electrically neutral agglomeration of ions, electrons and neutral atoms with temperatures up to 30,000°F. The electrical energy input per unit of propellant is much higher than the available thermal energy per unit weight of propellant in chemical rockets. As a result, the electrical rockets have much higher exit velocities, and are of interest for space propulsion where a small thrust operating for a long period of time is needed to accelerate a space vehicle. The Open House exhibits will also include a working model of a student built rocket. Orbits and trajectories of vehicles will be explained with the aid of a three-dimensional display portraying a typical space flight. ♦♦♦



Richard E. Covert, Iowa State BSME '62, utilizes an analog computer to study heat transfer transients and their effect on the control mechanism of a mobile military compact reactor being developed by the Allison Division of General Motors under contract to the Atomic Energy Commission. Covert is one of several young engineers now engaged in various studies connected with nuclear powerplant engineering programs at Allison.

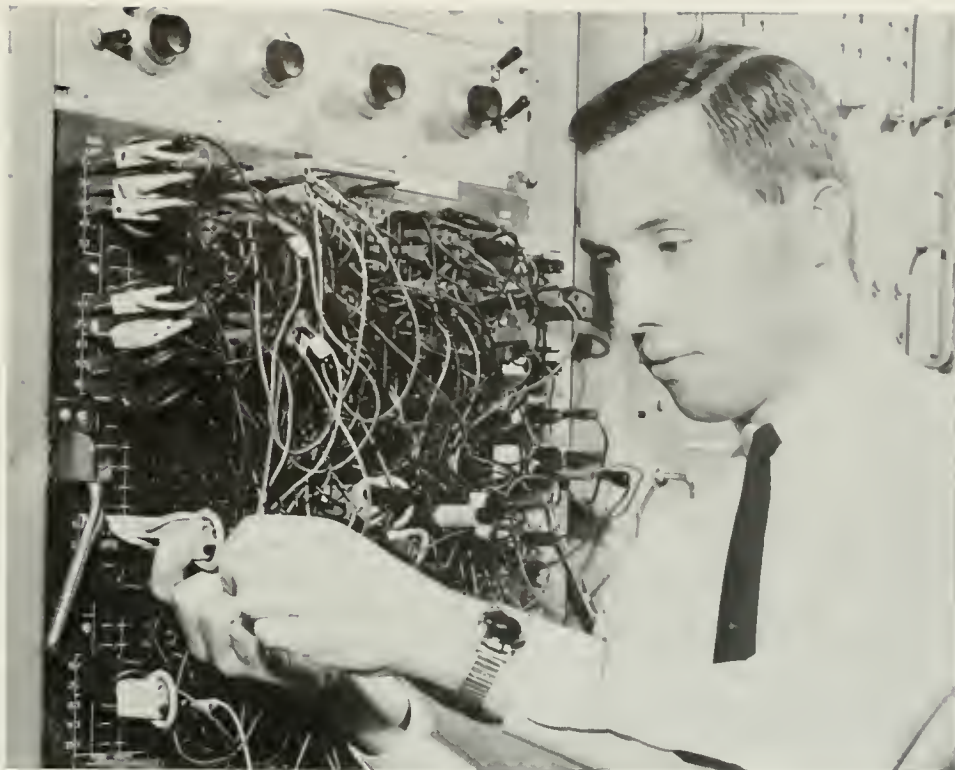

● **NUCLEAR ENERGY CONVERSION**—For the last 5 years, Allison, the energy conversion Division of General Motors, has participated in the design of various nuclear powerplants requiring compactness and low weight. Work on these projects has resulted in the compilation of a formidable background in nuclear systems engineering for space and terrestrial powerplants.

Announcement by the Atomic Energy Commission of the selection of Allison as prime contractor for development of MCR (Military Compact Reactor) now creates opportunities for well-qualified Engineers and Scientists in a long-range program in the nuclear field.

The MCR is a lightweight, completely self-contained nuclear reactor power system—easily transportable by truck, aircraft or rail—designed to provide packaged power for a wide variety of applications. It will have a high temperature, liquid metal cooled reactor coupled to a power conversion system. Incorporating long plant life characteristics compatible with military field equipment, the powerplant is expected to reduce the burden which shipment and storage of petroleum imposes on combat forces.

Along with its nuclear, missile and space activity, Allison is maintaining its enviable position as designer and producer of air-breathing engines. Recent developments include advanced types of turboprop engines for greater power with maximum fuel economy and without increase in engine size; a compact lightweight turboprop selected as the powerplant for the Army's next generation of Light Observation helicopters, and thermally regenerative gas turbine engines for a wide range of vehicular and industrial use.

Perhaps there's a challenging opportunity for you in one of the diversified areas at Allison. Talk to our representative when he visits your campus. Let him tell you first-hand what it's like at Allison where "Energy Conversion Is Our Business."

*An equal opportunity employer*

# Allison

THE ENERGY CONVERSION DIVISION OF  
GENERAL MOTORS, INDIANAPOLIS, INDIANA

# General

## E N G I N E E R I N G



Figure 1. A Mikrokator and a set of "Joe Blocks" used in precision measuring. The blocks are guaranteed accurate to within two millionths of an inch.

The General Engineer is a versatile man. His training combines an education in engineering principles with substantial work in a secondary field such as administration, geology or sales.

The graduate who has a broad engineering education plus a background in a less technical field is in constant demand by both industry and government. For example the salesman must know the technical product which he sells. The technical writer should understand the technical aspects of his subject as well as possess journalistic ability. The engineer of highways or structures who is competent in geology will be better able to choose the best geographic locations. The secondary non-technical options featured in the General Engineering program include engineering administration, engineering sales, engineering geology, technical writing, engineering law and meteorology.

All General Engineering exhibits will be located in the Transportation Building where many of the General Engineering courses meet. In the Hospitality Room, an exhibit illustrates the types of positions General Engineers occupy in industry. Geographical locations of the General Engineering graduates are depicted on a map of the United States. Students and staff members will be delighted to visit with you and discuss any phase of General Engineering.

Featured exhibits are described briefly below.

*Engineering Design:* Design is one of the most rewarding and demanding functions of an engineer. Engineering designs from major corporations will be displayed in their creative forms.

*Engineering Drawing:* Engineering students will demonstrate the fundamental geometry and procedures of graphic representation and engineering design.

*"Design for Production":* This is the title of a film which was jointly produced, in 1961, by the University of Illinois Department of General Engineering and a manufacturer of numerically controlled milling machines. This film shows how the engineering drawing, which presents shapes, dimensions and specifications, is correlated with the various machining operations to produce a precision product as a single item or in mass production. A second film, "Move the Mountains," which is concerned with material handling and earth moving equipment will be shown intermittently with the above film. The film depicts the changes in material moving methods from the ancient Egyptians to those of a present-day equipment manufacturer.

*Gauging:* It is impossible to make anything to exact specified dimensions; therefore, an important aspect of engineering is the determination of acceptable deviation from desired dimensions. A set of super-precision Johansson Gauge Blocks, which are basic measur-

ing units in industry, will be on display. These "Joe-blocks" have a guaranteed accuracy of  $\pm .000002$ " (two millionths of an inch). For example, a precision dial indicator, the Mikrokator, is set to a desired dimension for a machine part by using assembled Joe-blocks. The machine part is then manufactured within permissible limits by utilizing the preset Mikrokator.

*Air Brush:* The air brush is an instrument used in the shading of drawings. This will be an audience-participation display where visitors can try to produce art work with an air brush.

*Nuclear Reactor Model:* A model of a nuclear reactor will be on display. The model, used for orientations, illustrates the basic principles of our present-day high-powered nuclear reactors.

*Universal Drawing System:* This new system invented at the University of Illinois has been introduced in several schools and corporations. Drawings made with the system will be displayed showing how orthographic and isometric views are integrated in direct projection with each other.

*Law:* An engineer should know the legal aspects of his field. Of interest to engineers and other creative persons will be the display furnished by the U. S. Patent Office which explains the legal processes of protecting a new item.

The students and staff of the Department of General Engineering extend a cordial welcome to all. ♦♦♦



# Physics

This year the Physics Department will show the visitor intriguing displays on classical physics and current fields of research. Undergraduate students will present twenty minute lectures featuring demonstration experiments designed to show dramatically the wave properties of light, spectra of various elements, interference patterns, and other interesting optical phenomena. These lectures will be held in Room 100 Physics Laboratory, beginning on the hour and half hour; after each lecture, there will be time for visitors to ask questions and examine the apparatus.

For those interested in learning more about current research, there will be several displays in Room 112 Physics Laboratory. The popular low temperature physics display will be given again this year; this demonstration shows the many remarkable changes that matter undergoes when cooled. For example, a lead bell which responds with a dull thud when struck at room temperature rings clearly when struck after being cooled by liquid nitrogen. Normally flexible materials such as rubber and plastic shatter like fragile china when hit after cooling in liquid nitrogen.

This year, one of the newest research tools, the spark chamber, will be explained and demonstrated in Room 112 Physics Laboratory. The spark chamber makes use of the fact that a high energy charged particle passing through a gas such as neon leaves behind a trail of ions capable of conducting an electric current. The spark chamber, in its simplest form, consists of two thin metal plates, one of which is connected to ground and the other to a bank of charged capacitors. When a charged particle passes through the system, a sensing device causes the capacitors to discharge between the plates along the ionized trail left by the particle, producing a spark. Several sets of plates produce a series of sparks indicating the path of the particle. The ability of the spark chamber to select the particles that it observes makes it extremely useful in the study

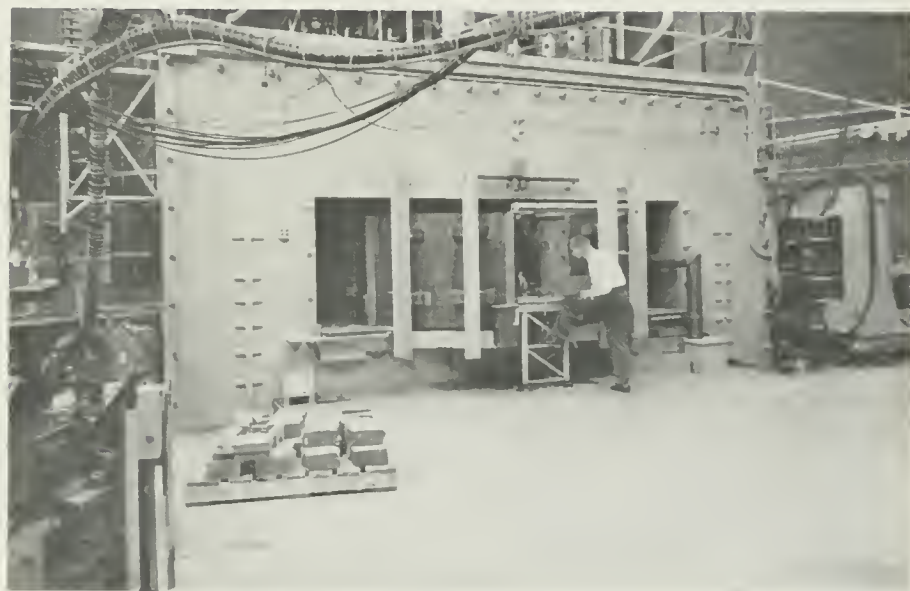

Figure 1. A closeup of the 340 MEV Betatron used for basic research. The Betatron is one of the open house attractions.

of elementary particles. By allowing the capacitors to discharge only when an interesting particle has passed through the system, a photograph showing only the desired track can be obtained. Photographs made from older devices such as the cloud chamber and the bubble chamber contain many extraneous tracks in addition to the one of interest. A cloud chamber and the well-known Geiger-Muller counter will also be displayed in Room 112 Physics Laboratory.

One of the new features of this year's Open House will be an information booth located in the main corridor of the Physics Laboratory. Student and faculty advisers will be available at this booth to answer questions that prospective students may have about high school preparation or the program of study leading to a degree in physics at the University of Illinois. The Physics Department will also show several movies especially prepared to illustrate some

principle of physics in a way that is both interesting and easy to understand. These movies will be shown continuously in Room 119 Physics Laboratory.

The betatron will be open to the public again this year and because of improved bus service it will be more accessible than in the past. Busses will leave the Engineering Campus for the Assembly Hall and the betatron every five minutes. The betatron was invented here at the University of Illinois by Professor Donald Kerst in 1940. It differs from most other large particle accelerators in that it produces high energy electrons rather than high energy protons. Since 1940, the University has constructed several betatrons, the largest of which is capable of producing 340 million electron volt electrons. The electron beam produced by the betatron may be made to strike a metal target, thus producing high energy x-rays which are useful in many experiments. ♦♦♦

# Army ROTC



Figure 1. Unmanned aircraft send back aerial views of distant sites, using light TV equipment developed at the Army's Signal Corps Engineering Laboratories at Fort Monmouth. The camera in the L-17 drone (shown in telescopic view) can point downward or forward through the plane's belly.

This year the Engineer, Ordnance, and Signal Army ROTC branches will jointly participate in Engineering and Science Weekend. The latest equipment and activities characteristic of these branches will be exhibited and explained in the display.

The Corps of Engineers, the world's largest engineering organization, will exhibit equipment used in support of its combat, technical service, military construction, and civil works mission. A lighted transparency depicting major construction projects in Illinois will accentuate the role of the Corps of Engineers as manager of our nation's flood control and waterway development programs. A variety of bridge models will show one phase of the Engineers' combat mission of keeping your Army moving forward. For those with a little

more time and interest, a half-hour color film dramatically depicting past, present and future world-wide engineer missions will be shown near the display.

The Ordnance branch will display several of the Army's newest weapons. The first of these weapons is the 7.62 mm, M14 rifle—the new shoulder weapon for the individual soldier. Secondly, the display shows the 7.62 mm, M60 machine gun, which provides the accurate, sustained fire power that the infantryman needs. Also, to be displayed is the 40 mm, M79 grenade launcher, which is used for projecting high explosive grenades between the maximum range of hand grenades and the minimum range of mortars. These are just a few of the items that will be present at the United States Army Ordnance display. Ordnance has a four-level func-

tion concerning the United States Army's materiel. They are responsible for the research and development of all of the Army's materiel as well as the industrial manufacturing of the items. After the material is ready for the using unit, Ordnance supplies the proper training to get the most effective use from its operation. At the last Ordnance functional level, we have the field service which supplies needed repair parts, ammunition, and any other logistical need of the using unit.

The Signal Corps will display tactical Signal Corps field equipment such as field switchboards, light radios and telephones, teletypewriters and multichannel carrier equipment. Four static display cases will also show developments in miniaturization, transistors, communications, satellites, battlefield surveillance drones and ADPS applications. A twelve-minute film explaining recent developments will be shown hourly. ♦♦♦



Figure 2. The M-14 rifle has been adopted by the armies of the North Atlantic Treaty Organization and fires the standard NATO 7.62 mm cartridge. It replaces the Browning Automatic Rifle, M1 Garand Rifle, carbine, and Caliber .45 sub machine gun. It is a semi-automatic weapon and can easily be converted by the soldier to fully automatic.





If you want a career in Space Electronics . . .

## YOU SHOULD BE AT COLLINS

Why? Consider this. Every American voice from space — from the X-15 to Schirra's 6-orbit flight — has been carried back to earth by Collins communication systems. The men who designed and engineered the equipment and put these systems together are topnotch experts in their fields. These are the men you'll have an opportunity to work with and learn from on a variety of space communication project assignments. □ Our company is currently engaged in another phase of the U. S. space effort, communication systems for NASA's Apollo manned lunar spacecraft. Again Collins can provide young engineers with an opportunity to advance and grow through actual experience on projects such as this and through close working contact with the experts. □ Future Collins commitments call for further exploration in the field of space communication and the equipment and systems necessary for contact between spacecraft and earth. It's a field full of challenge and opportunity for the young engineer wishing to carve out a satisfying career in space electronics.

If this fits in with your plan — and if you have a B.S. or advanced degree in E.E., M.E., Mathematics or Physics, contact your Placement Office or write to the Collins science center nearest you.



L. R. Nuss  
Collins Radio Company  
Cedar Rapids, Iowa

C. P. Nelson  
Collins Radio Company  
Dallas, Texas

E. D. Montano  
Collins Radio Company  
Newport Beach, California



*Your Home  
On Campus*

# MEDEA and MEDEA LODGE

412 and 408 East Green

Two Blocks from Engineering Campus

**Room and Board  
Intramural Sports  
Social Activities  
Quiet Hours for Study  
Close to Engineering  
Campus**



A skit for relaxation



Evidence of effort

Medea, one of the finest Independent Men's houses on campus, offers small group living with the advantages of a larger house. Living at either Medea or Medea Lodge assures you of an excellent location, fine food (T-bones once a week), coffee an' served every morning, good study conditions, linens—all for \$800.00 a year.



Technocutie . . .

## Miss Lois Backer

. . . What? An Engineer?



Increased rumors of several unidentified creatures — creatures resembling “girls” — have been circulating on the Engineering campus for some time. With the help of the Society of Women Engineers it didn't take TECH long (there were more than anticipated) to locate one, and here she is . . . lovely Miss Lois Backer—one of 23 charming women engineering students who are adding a touch of grace to our previously homogeneous engineering campus.

Lois was valedictorian of her Roanoke High School class, and she is now a 4.5 plus General Engineering freshman whose domestic talents acquired during five years of 4-H, should appeal to every engineer. Her beauty is self-radiating, but just for the records, she has been a Dolphin Queen semi-finalist as well as a Miss Woodford County contestant in the Miss America preliminaries.

Only one problem remains—where can TECH find another photographer? . . . Ours has found a new hobby—“Creature Watching”! As a matter of fact, where is the rest of the staff? . . . Hey fellows . . . wait for me!



a  
message  
to  
graduating  
engineers  
and  
scientists

AT PRATT & WHITNEY AIRCRAFT...

**YOUR EYES CAN BE ON THE STAIRS**

SPECIALISTS IN POWER . . . POWER FOR PROPULSION—POWER FOR AUXILIARY SYSTEMS.  
CURRENT UTILIZATIONS INCLUDE AIRCRAFT, MISSILES, SPACE VEHICLES, MARINE AND INDUSTRIAL APPLICATIONS



## PUT YOUR FEET MUST BE ON THE GROUND

The glamour and excitement of space age programs often obscure a fundamental fact. It is simply that farsightedness must be coupled with sound, practical, down-to-earth engineering if goals are to be attained. This is the philosophy upon which Pratt & Whitney Aircraft's position as a world leader in flight propulsion systems has been built.

Almost four decades of solid engineering achievement at Pratt & Whitney Aircraft can be credited to management's conviction that basic and applied research is essential to healthy progress. In addition to concentrated research and development efforts on advanced gas turbine and rocket engines, new and exciting effects are being explored in every field of aerospace, marine and industrial power application.

The challenge of the future is indicated by current programs. Presently Pratt & Whitney Aircraft is exploring the areas of technical knowledge in *magnetohydrodynamics . . . thermionic and thermoelectric conversions . . . hypersonic propulsion . . . fuel cells and nuclear power.*

If you have interests in common with us, if you look to the future but desire to take a down-to-earth approach to get there, investigate career opportunities at Pratt & Whitney Aircraft.

To help move tomorrow closer to today, we continually seek ambitious young engineers and scientists. Your degree? It can be a B.S., M.S. or Ph.D. in: **MECHANICAL • AERONAUTICAL • ELECTRICAL • CHEMICAL and NUCLEAR ENGINEERING • PHYSICS • CHEMISTRY • METALLURGY • CERAMICS • MATHEMATICS • ENGINEERING SCIENCE or APPLIED MECHANICS.** The field still broadens. The challenge grows greater. And a future of recognition and advancement may be here for you.

---

For further information regarding an engineering career at Pratt & Whitney Aircraft, consult your college placement officer or write to Mr. William L. Stoner, Engineering Department, Pratt & Whitney Aircraft, East Hartford 8, Connecticut.

---

# Pratt & Whitney Aircraft

CONNECTICUT OPERATIONS EAST HARTFORD, CONNECTICUT

FLORIDA OPERATIONS WEST PALM BEACH, FLORIDA

DIVISION OF UNITED AIRCRAFT CORP.



An Equal Opportunity Employer

# Women in Engineering

by Pat Martin

In small but increasing numbers, American women are distinguishing themselves as engineers. The persisting idea that engineering is a hard and rough occupation unsuitable for women has been refuted by the women who have pioneered and succeeded in this field. Today the tremendous number of women in all Russian technical fields shows us an excellent example of how this untapped resource can be utilized. Surprisingly, this utilization of women has not slackened their pace, but rather helped them in the space race and certain other areas.

In America, as prejudices are slowly decreasing, the number of women in engineering has increased. In 1950 there were some 6,500 women engineers, in contrast to less than 750 in 1940. All evidence indicates this rising trend will continue.

Women who choose—for one reason or another—to enter engineering have before them a varied, interesting, and exciting college career. Even now, with many successful women in engineering, college girls are often advised not to enter engineering. As a result many potential women engineers never experience the challenge, excitement, and pride of an engineering profession.

The first challenge comes when someone asks what you are majoring in. A woman engineering student soon learns to tolerate criticism and those who come up with the universal questions such as, "Did you go into engineering just because that is where all the men are?" The challenge comes in proving to the world that all women engineers are not two-headed, sexless creatures who wear shapeless dresses and horn-rimmed glasses. The challenge comes in wearing skirts and being feminine in a traditionally man's world, and still proving that you can do a good job. And the challenge comes most of all in making a success . . . in getting through college and earning that treasured degree . . . in going into industry and being an

asset to your country and your employer.

The excitement comes in many ways. It comes while standing in lines those first few days and returning wondering stares of the men about you. It comes during the first classroom days when you notice the ratio of men to women, and when your instructors persistently call the roll it is always Smith, Brown, White, and then, Miss Jones. It comes from figuring out a difficult problem or from receiving a good exam grade. It comes from winning the respect of the people around you, men and women. It also comes in a very special way when you attend a dance with your special beau and meet the people from your classes who stare in wonder and obvious admiration to see you at a dance with a boy and really looking quite feminine and pretty. It comes in dating men and being able to talk to them intelligently; in being able to listen and understand. It comes most of all when you discover that you are finally being treated as an equal; the men around you have accepted you and are ready to help you and to be helped, are ready to accept the astonishing fact that you are a woman engineer and most of all a Woman. It has often been said that college life is the most exciting time of a woman's life. It is sometimes hard to realize that this is doubly true of a woman engineering student. She has all of the normal excitement, and so much more if she can only meet the challenge.

And then there is Pride . . . that funny little word that creates an inner glow that can grow into a fire . . . that funny little word that drives people onward to bigger and better goals . . . that makes them try harder when it seems almost impossible . . . that word that makes a person want to be different and special . . . that drives someone to the point of exhaustion and leaves them happy merely because they are proud of their accomplishment, and they can see pride reflecting in the faces of the

people around them. Pride . . . an undefinable word that means the world. It is a sparkle of happiness that you are doing what you are doing, a fascinating aura of joy that you are what you are and nothing else. This is what it takes to become a good woman engineer. This is the spirit, combined with dedication and hard work, which caused our pioneering women to become engineers and to succeed in spite of what society and near-sighted people said and did to make it hard for them.

Today the problem is supplying adequate high school counseling to women whose aptitudes in math and science point to an engineering career. The Society of Women Engineers is trying to help in this respect by counseling high school seniors. In the coming years it is possible to envisage more and more women making a success in engineering. At the present moment there are 23 women enrolled in engineering at the University of Illinois. These women are scattered throughout all branches of engineering.

The rumors of hard work and no fun are partly correct. True, engineering isn't easy; but in actuality few free things are worthwhile. A woman should not be forced into engineering. It must be something she freely elects with her eyes open and her chin firmly set, since there are times when things seem almost impossible to bear; times when the easy thing to do would be to simply give up and try something else. A young woman entering engineering must be fully aware of what she is doing. She must be proud of her work and stand up for it; she must be ready to give up some of the small things she wants now and keep sight of the further more important goals; she must be ready to meet the challenges that will inevitably come. But the thing to remember is that when it is all done, and the hardships and worries are over, you will have something, something special, precious, and worth much more than it cost. ♦♦♦



# THE BELL TELEPHONE COMPANIES

## SALUTE: CAL CRIMP

Michigan Bell makes few moves in Southfield without consulting Engineer Cal Crimp (B.S.E.E., 1957). Cal makes studies on where to put new central offices, how to expand old ones, what switching equipment to order.

To make these decisions, Cal must interpret forecasts of customer growth. He must also know his equipment and operating costs closely. Such responsibility is not new to

him. On an earlier assignment, for instance, he skillfully directed a drafting section of 32 people.

Cal Crimp of Michigan Bell Telephone Company and the other young engineers like him in Bell Telephone Companies throughout the country help bring the finest communications service in the world to the homes and businesses of a growing America.



### BELL TELEPHONE COMPANIES



TELEPHONE MAN-OF-THE MONTH



## Must you join a giant company to work on big projects?

Take Consolidated Edison's Indian Point nuclear power station near New York City. Several giant companies contributed to her success. But her most significant feature—the reactor—was designed and built by Babcock & Wilcox.

*B&W is large enough to win contracts for big projects.* 1962 sales, for example, were more than \$320 million. And every year, B&W invests many millions of dollars in research and development. B&W offers many other advantages of the large company: formal training program, paid tuitions, wide variety of job openings (17 plants in 9 states), plus the security and benefits of a large, established organization.

*B&W is small enough to give you a chance to work on big projects* early in your career. There are 149 larger industrial companies in the U. S. Growth opportunities are enormous. Yet only 47 bachelor-level students will be hired in 1963.

B&W has interesting job openings for graduate and undergraduate engineers and scientists, including M.E., E.E., Ch.E., Met.E., Cer.E., Nuc.E., and physicists. For more information, talk to the B&W interviewer when he is on your campus or write to J. W. Andeen for "Your Career Opportunity at Babcock & Wilcox." The Babcock & Wilcox Company, 161 E. 42nd St., New York 17, New York.

**Babcock & Wilcox**



# NAVAL ROTC

fied of the results in time for registration. These Midshipmen take one naval science course each semester and receive a commission upon graduation. They are supplied with uniforms and Naval Science textbooks and about \$27 per month during their junior and senior years. They also participate in one summer training cruise between their junior and senior years.

In addition to service orientation, history of sea power, psychology of leadership, navigation and operations each Midshipman studies ballistics, computers, directors, guided missile propulsion, guidance and control in his naval science courses. He will receive additional training in naval engineering and the functions of the engineering department aboard ship, including ship stability, fundamentals of heat engines, boilers, steam turbines and the necessary components, and a basic study of the fundamentals of nuclear propulsion.

Upon graduation and commissioning the Navy offers qualified officers postgraduate training in most fields of engineering. A good example is the Navy's excellent nuclear power school which trains officers for work with nuclear reactors. ◆◆◆

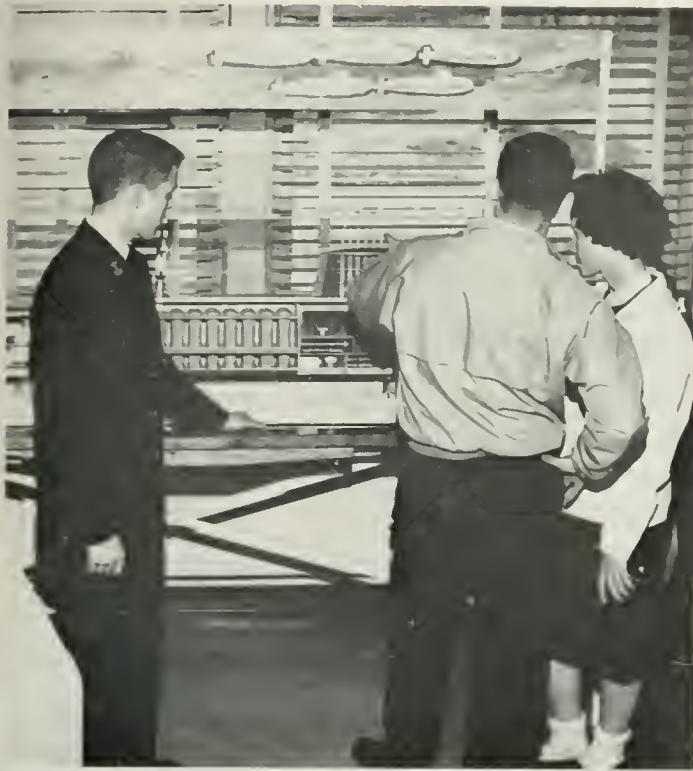

Figure 1. Several students are shown taking in the Navy's Polaris Model display at last year's Open House.

This year many Midshipmen are displaying the latest in operational weapons and space technology. The Naval Ordnance Plant at Forest Park, Illinois, will display an eight-foot model of the Sidewinder, an operational air to air missile. Somewhat more important is the exhibit on the Navy's formidable Polaris missile firing submarine. This exhibit will include a large model displaying the inside of the sub and selected photographs of the Polaris in action.

This year's most spectacular exhibit, however, will be the large plastic model of the new Gemini Space Capsule. This capsule is much larger than the Mercury Capsule and is designed for two astronauts. Smaller models will be displayed of the Gemini on a Titan rocket and the Gemini on para glide. There will be pictures of the launch sequence and an exciting 22-minute color film showing Gemini's launch to landing sequence—a must for Open House visitors who are interested in our "man in space" programs.

There will be displays concerned with the Naval research program; a dynamic display explaining the Navy's research in gas lubricated bearings; and a display of the Navy's giant radiotelescopes. One of these radiotelescopes is located nearby at Danville, Illinois, where it will pick up radio signals from outside our galaxy. These exhibits will be explained by Naval ROTC students.

Graduating high school seniors can still enter the Naval ROTC program this fall. A student desiring to become a Contract Midshipman must present himself in person at the Administration Office of the NROTC unit. This can be done as early as the last half of the senior year in high school or in the summer before entering the University—it should not be later than the first part of Freshman Week. Those applicants who are found acceptable will receive a written exam and be noti-



Figure 2. Pictured above is the Alexander Hamilton SSB(N) 617 being launched in August 1962. The Hamilton is a Polaris submarine about which further information can be obtained at Open House.

The design is thousands of years old. Called "Man," it has evolved reasonably efficient techniques for coping with weather, saber-toothed tigers, city traffic, floods and income taxes. □ But now it faces a problem of a new order of magnitude...survival beyond the protective cocoon of the earth's environment. In this airless, weightless, radiative region, man needs a big assist. Douglas is working to provide it. □ Douglas scientists are far along in studies of ecological systems for the maintenance of human life under

**EARTH'S MOST COMPLICATED SYSTEM** extra-terrestrial conditions. These research areas cover the  
**...A STIMULATING AREA FOR CREATIVE ENGINEERS** varied life and physical sciences and engineering systems which are involved. They range from psycho-physiological analyses to the actual planning of the establishment and support of cities on the moon.



The above is only one of hundreds of interesting assignments at Douglas. If you are seeking a stimulating career with an organization in the thick of the most vital programs of today and tomorrow, we invite you to contact us. Write to Mr. S. A. Amestoy, Douglas Aircraft Company, 3000 Ocean Park Boulevard, Santa Monica, California. Box 600-M. Douglas Aircraft is an equal opportunity employer.





# Civil Engineering

One of the most common complaints among engineering students is that they are barricaded scholastically by required courses. Civil Engineering at the university has recognized this restriction and a new program will begin next fall. This program will allow the student to overcome the required specialization to whatever degree he desires.

One combination which comes to mind is that of the aeronautical structural engineer. A civil engineer's background in structures plus proper selection of courses in aeronautical engineering could qualify an engineer for structural work in the rapidly expanding missile field.

In addition to allowing a student who is certain of his desired field to obtain his goals, the new curriculum gives the student who is not certain an insight into possible fields of interests. Complete information pertaining to the new curriculum will be available at a special exhibit. The exhibit will have both staff and students available for questions or additional information on the curriculum changes.

Civil Engineering, being one of the most diversified fields of engineering, requires training in many areas. The field of *Highways* is at this time one of the most rapidly expanding in civil engineering.

Closely related to the development of highway facilities is the problem of traffic control. The *Traffic Engineer* is responsible for the safety and efficiency of a highway design. With the ever increasing volume of traffic on our highways, the need for adequate traffic control becomes more evident. The Traffic Engineering Laboratory located in 408 Civil Engineering Hall has on display some of the equipment needed to evaluate traffic conditions and to control this traffic once the conditions are determined. Also potential speeders may get a closer look at that "little black box" used in radar speed detection. Traffic

signal controls for several Urbana inter-sections will be operating from the lab during Open House. The complexity of a coordinated traffic system will be demonstrated in the lab.

One of the newer fields in civil engineering is that of *Soil Mechanics and Foundations*.

A soil and foundation display located in room 202 Talbot Lab will demonstrate factors affecting soils when used as foundation materials and the different types of soils as they are classified in foundation work. A series of pictures will demonstrate the many facets of soils engineering and some of the problems encountered in applying those facets. The behavior of a soil under an applied load is demonstrated by the settlement and consolidation exhibit. The quicksand exhibit will offer no threat to visitors although its potentials are amply demonstrated.

The civil engineer entering *Surveying* will find very modern and highly complex equipment applied to this very old art. Equipment is available which will measure distances of twenty miles or more extremely accurately. Some of the newest equipment in the field will be on display in the Surveying exhibit. Within the field of surveying, *Photogrammetry* is becoming more popular. Through the use of aerial photographs accurate elevations and distances may be obtained for engineering work by photogrammetry. This procedure is finding increased usage in the preparation of maps, soil surveys and highway design. The basic fundamental of photogrammetry—that of 3-D viewing of two photographs—is demonstrated in the surveying display.

Skyscrapers, bridges, flagpoles, television towers and airplane wings are just a few examples of the *Structures* with which the civil engineer is concerned. The complexities of structure loads vary from snow loads to that of a nuclear blast.

The field of *Construction* is becoming increasingly complex with new technology and equipment and with the ever increasing degree of competition in the industry. No longer are the previous construction methods being relied upon to obtain competitive bids or to make money once a contract is won. The present day construction engineer must investigate cost analyses and estimates, time study and productivity, and job planning. Statistical analyses and computers are being applied to construction. Throughout his career, the construction engineer is called upon to apply principals of every field in civil engineering from soils to traffic.

An example of a typical construction project is that provided by Chi Epsilon, civil engineering honorary fraternity, of a model of Glen Canyon Dam in its finished state plus data used in design and construction.

The *Hydraulics* engineer is concerned with the design, development and use of water resources and facilities. The increasing needs for water are forcing the hydraulic engineer to develop new sources and to provide means of preserving present supplies. Flood control, culvert design, dam design and irrigation are all part of the hydraulic engineer's work.

One example of a hydraulic design at Open House is that of an energy dissipator. This display will demonstrate the work that is being conducted at the University of Illinois on hydraulic energy dissipators for culverts. With water actually flowing, the exhibit will compare the performance of two box culverts, one with dissipator and the other without. The relation of energy dissipation to soil erosion will be shown by this exhibit.

Of special note about this exhibit is that it was prepared as part of an actual laboratory study that is being conducted

(Continued on Page 54, Col. 1)

# Agricultural Engineering

Agricultural engineering is a growing and expanding profession which is meeting the engineering problems of an advancing agriculture. As new machinery, processes, structures and soil conservation practices are developed, agricultural crops can be harvested more rapidly, more efficiently and with greater quality. At the same time new structures with environmental control give healthier, more productive animals, and conservation studies insure the necessary natural resources to meet future requirements. Supplying the technical engineering know-how required to handle crops, produce animals, and manipulate soils is the challenge of the agricultural engineer.

The academic staff of the Department of Agricultural Engineering is composed of professionally trained engineers who, in addition to teaching, apply their knowledge toward solving agricultural problems. Students likewise are encouraged to think and do agricultural research.

A student not only receives sound classroom instruction, but also sincere advice and counsel from an interested faculty. His advisor is a qualified staff member who has many years' experience in engineering and a thorough understanding of the student's program and problems. The progress of the student from his entrance in college until his university career is terminated, hopefully through graduation, is followed by the advisor. The advisor is extremely important in helping the new student plan his course of study as related to his high school record and his personal and professional goals following graduation.

The entrance requirements for agricultural engineering students are identical to those in the other departments of the College of Engineering: high school training in mathematics, science, rhetoric, social studies, and a foreign language. If a person is deficient in one of these, he may make up the deficiencies at the university. A farm background is, of course, helpful in gaining practical insight into agricultural problems.

A supplementary student activity—encouraged by the department—is participation in the Illinois Student Branch of the American Society of Agricultural Engineers. This group attempts to develop leadership and cooperation by planning and executing various projects

during the year. One such project is the *Agrineer*, the agricultural engineering student annual, and another is the work done for Engineering Open House. The students plan and build the Open House displays to publicly demonstrate the agricultural engineering accomplishments. Such experience—in addition to formal classroom and laboratory training in structures, soil and water mechanics, electric power and

processing, and field power and machinery—is highly valuable to the graduated engineer.

A few areas where an agricultural engineer may work are: machine design, processing of farm products, farm structures and environmental control, project managing in an agriculturally related industry or in other production areas requiring engineering know-how. ◆◆◆



Figure 1. Aerial view showing the Agricultural Engineering display building and contrasting machinery display.

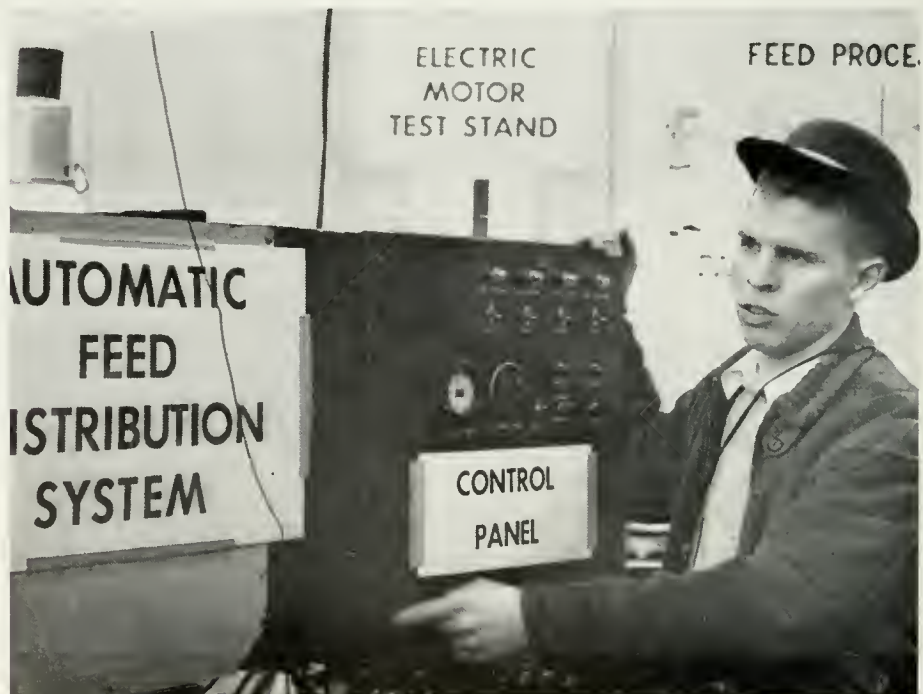

Figure 2. Jerry Weibel demonstrating the pneumatic feed distribution system at last year's open house.



# Chemical Engineering

Chemical engineers are concerned mainly with "scaling up" processes discovered by the chemist in the laboratory. That is, the chemical engineer first decides whether or not a process is economically feasible and, if it is, designs the equipment which will be used in the process. Chemical engineering, however, is not limited to production alone; many chemical engineers also work on basic research.

In the Division of Chemical Engineering at the University of Illinois, research is being carried on in many fields: mass transfer, heat transfer, fluid flow, reactor design, process dynamics, and high pressure technology. This variety shows that a degree in chemical engineering from the University of Illinois is often not the end, but a springboard for further study in one of many fields not commonly related to chemical engineering.

During the Engineering Open House, chemical engineering students will present two sides of their field—theoretical research and practical engineering applications.

## Practical Applications

Most of the Open House exhibits will be shown in the "Unit Ops Lab." This laboratory occupies three floors of the East Chemistry Building and will have many industrial scale operations displayed in it. Equipment for evaporation, gas absorption, distillation, and filtration will also be shown. In the "Unit Ops Lab" the undergraduate student experiences his first contact with practical applications of classroom theories.

The first display visitors will view in the lab is the Chem Pop exhibit. This exhibit will provide a cool, carbonated drink while demonstrating the operation of gas absorption. Of primary importance in this exhibit is a fifteen-foot, glass-packed column through which visitors can see the action of gas bubbling through the liquid.

A new addition to the lab is an all-glass distillation tower through which visitors can see the operation of the bubble cap trays. The unit was installed early this year and replaces a bronze, six-plate column which had been used in the past to show how the various components are separated.

Several other displays will also be displayed in the "Unit Ops Lab." Among these will be a filtration exhibit showing two types of industrial filters—a stirred tank reactor used for both reaction kinetics and process dynamics studies and a drop evaporation experiment where the rate of evaporation of a drop is measured and used to compute a diffusion rate for water vapor through air.

A series of displays in another room will introduce visitors to a vital segment of chemical production—measurement and control. The displays shown here are the instruments and controls necessary for the operation of a chemical plant. These instruments are basic to the growing field of automation. Devices such as the optical pyrometer, thermocouples, potentiometers, and recorder-controllers will be shown and explained to the visitor.

## Theoretical Research

Up to this point all of the displays mentioned have been directly related to industrial operation. Two other displays will show research projects which could ultimately be used by industry, although they were not designed specifically for industrial application. Both experiments were designed by senior students working with a faculty advisor. One experiment deals with reactor design; the student is attempting to vary the time during which reactants in a stirred tank are in contact, by varying the location where the products are taken off. The other experiment deals with the transition of flow patterns in a water jet falling vertically from a nozzle. The study is being made by measuring the diameter of the jet as it falls and then correlating this data with analytical equations.

Finally, the visitor can view several movies dealing with chemical engineering and also attend the highly entertaining "Chem Magic Show."

In conclusion, University of Illinois chemical engineering students realize they can show only a small portion of their vast field to visitors, but it is hoped that this representative portion will demonstrate the activities and challenges facing the modern chemical engineer.◆◆◆

# At IBM you design systems that bring space down to earth

In research and development at IBM, engineers and scientists are exploring new methods, materials, and ideas—a new world of data processing tools and techniques to extend the reach of man's mind. In space, IBM miniaturized computers will guide satellites into orbit, gather information from the stars, store data, and relay it on command back to earth. The IBM developments that make possible these systems for broadening man's grasp of the universe—and the new technologies that result from the application of data processing systems—form a firm basis for further progress in the development of information systems.

IBM is at work on applications of data processing concepts to meet the urgent need for effective information handling systems for gathering vast quantities of data, assembling collected data, storage, and making vital information instantly accessible. For example, large-scale computer systems have been developed for coordinating the coast-to-coast network of airline flight reservation. Other computer systems handle research calculation for nuclear and thermonuclear energy. For automatic bank check processing, systems read characters imprinted on checks with magnetic ink.





a new world of concepts in data processing

With each new advance in the application of data processing, new worlds of opportunity are opening up for engineers, scientists, and programmers at IBM. The exploration of data processing methods offers a range of stimulating assignments in engineering, design, and development. Projects now under way at IBM include: Automatic language translation • Industrial process control • Long-range weather prediction • Space-borne inertial guidance systems • Systems using plain language instructions and programming for computers • Information retrieval systems which locate document pages in seconds.

There's an immense challenge in developing new concepts in data processing. At IBM you can build a rewarding future in fields such as: Physics • Chemistry • Mathematics • the Engineering Sciences • Solid State Phenomena • Systems Design • Circuitry and Logic Design. The IBM advanced-education program provides educational backing for earning graduate degrees in the field of your choice. IBM, an Equal Opportunity Employer, offers a full range of company-paid benefits. For further details on career opportunities, write to Manager of Employment, IBM Corp., Dept. 915, 590 Madison Ave., N. Y. 22, N. Y.



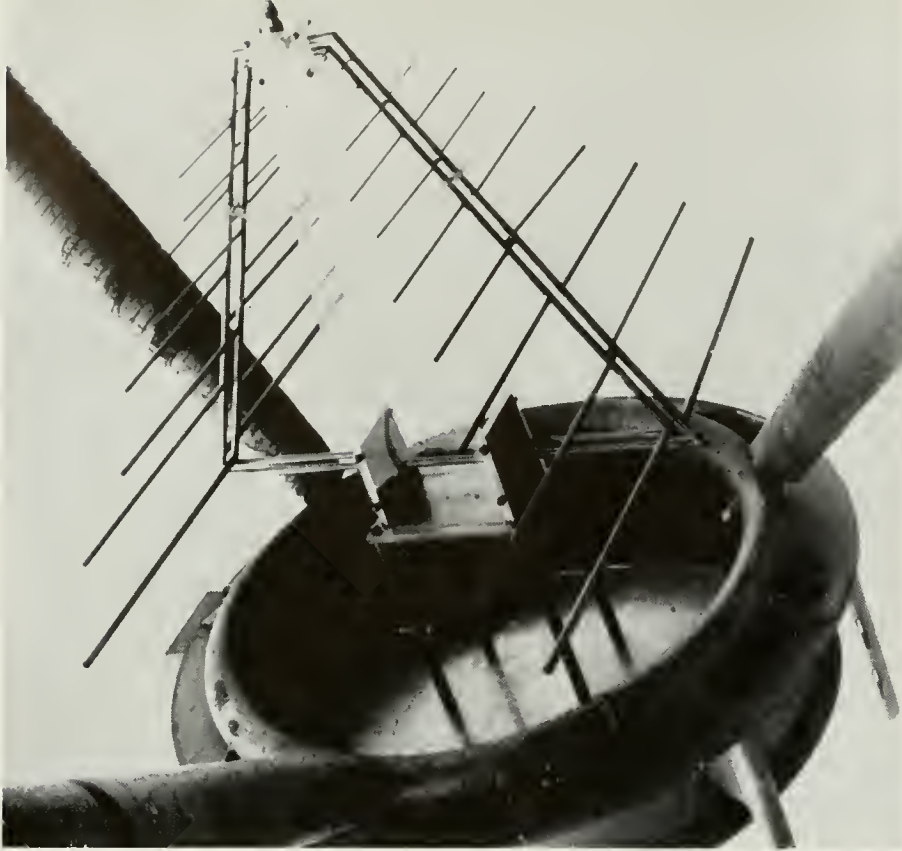

Figure 1. Pictured above is a Log-Periodic Dipole Antenna. This type antenna was invented and developed at the University of Illinois.

# Electrical Engineering

Electrical engineering, as we know it today, is one of the youngest of the engineering professions, having come into existence only within the past fifty years. Its growth, however, has been phenomenal, and today the term "electrical engineering" describes a field so immense and diversified that it is being applied not only in other phases of engineering and science, but, with the advent of computers and data-processing devices, in everyday business life.

Products of electrical engineering research can be found in every phase of life—even in the field of medicine. Here, probably the best known contribution is the heart-pacer, an electronic device which automatically stimulates the heart and which can be concealed on, if not implanted in, the body.

Electrical engineering is based on the science of electricity, which is one of

the youngest branches of physics. Although the early Greeks knew of the attractive properties of rubbed amber, they could not explain them, and it was not until the 15th and 16th centuries that electricity and its properties really began to be investigated. Within a span of a few centuries the work of Gilbert, Franklin, Volta, Coulomb, Galvani, Faraday, Ohm, Ampere, and many others had contributed to the creation of the electrical engineering profession. In the late 19th and early 20th century, scientists, physicists and experimenters such as Henry, Hertz, Edison, Fleming, DeForest and Maxwell (a name familiar to all EE's) were discovering and experimenting with the properties of electricity and electro-magnetic waves.

In the past electrical engineering was conveniently divided into two main categories—power and communications—

classifications which are becoming increasingly more difficult to follow.

The battery, developed by Volta, was the main source of power until the 1870's when men like Faraday, Saxton and Clark did extensive work on electrical generators and motors. With the development of the incandescent lamp and dynamo by Edison and the increasing efficiency of generators and motors spurred on by the work of Westinghouse and Tesla, the area of electric power was becoming more and more extensive.

Paralleling the expansion of power were the advances of Wheatstone, Morse, Bell and others who were pioneers in the area of information transmission over wires while Hertz, Marconi, Armstrong, and Zworykin investigated "wireless" communications. The first radio station began broadcasting in 1920 and the first television station began operation in 1941, although the idea of electronic television was conceived as early as 1908.

Since the first radio stations became operative, there has been an ever-increasing demand for greater information carrying capabilities, which are rather limited at the lower frequencies (kilocycles). As a result, there has been a continuous drive to extend the upper limit of obtainable frequencies. At present, the frequency range has been extended to the gigacycle range ( $10^9$ c.p.s.) and beyond with devices like klystrons, magnetrons and traveling wave tubes. The optical spectra is being investigated with quantum electronic discoveries such as lasers (a contraction of light amplification by stimulated emission of radiation).

In addition to the enormous expansion of the two fundamental areas of electrical engineering—power and communications—advanced technology has given birth to the new areas of medical electronics, ultrasonics, quantum electronics, superconductivity, and cybernetics. With the increased interest in space exploration have come new areas such as radio astronomy, high speed computers and memory systems, ionospheric and plasma physics, and of course microminiaturization—all of which are within the realm of electrical engineering.

These are but a few of the many topics in electrical engineering which have appeared in the last twenty years. It is easy to see electrical engineering has advanced rapidly since the days of Galvani and his "frog's legs." To be sure, electrical engineering has only begun—as is true with all human knowledge. A young student entering the profession can pick from scores of areas for investigation—all fascinating and challenging. ◆◆◆



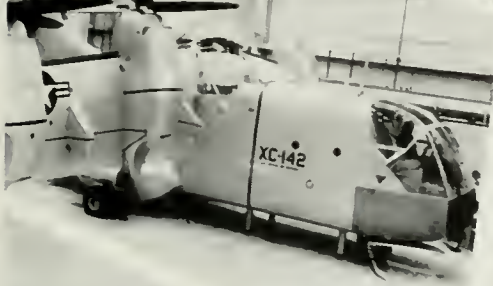

## **TARGET OF OPPORTUNITIES** | LING TEMCO VOUGHT

Opportunity for professional advancement, on-the-job orientation and engineering challenge... you'll find this and more with Ling-Temco-Vought. From the first you'll work with experienced technical personnel in an engineering climate that encourages imagination and spontaneity. And because LTV is one of the nation's most active participants in almost every phase of the challenging aerospace, communications and military electronics fields, you can determine the type of promising position which will contribute most to your professional growth. ■ Get first-hand information on LTV's projects and products by picking up our brochure at your Placement Office. Then contact our College Relations representative. Ask about the company's extensive resources, education assistance and liberal company benefits. Ask, too, about Dallas—a modern city noted for its warm, sunny climate. Then review LTV's ground-floor growth opportunities for graduates holding degrees in Aeronautical, Mechanical, Industrial, Electrical and Civil Engineering or Math, Physics and Metallurgy. ■ For further information, visit your Placement Office or write College Relations Office, Ling-Temco-Vought, Inc., P. O. Box 5907, Dallas 22, Texas. An equal opportunity employer.

**LTV** LING-TEMCO-VOUGHT INC

Dallas Area Divisions: CHANCE VOUGHT CORP./TEMCO ELECTRONICS/TEMCO AEROSYSTEMS/CONTINENTAL ELECTRONICS



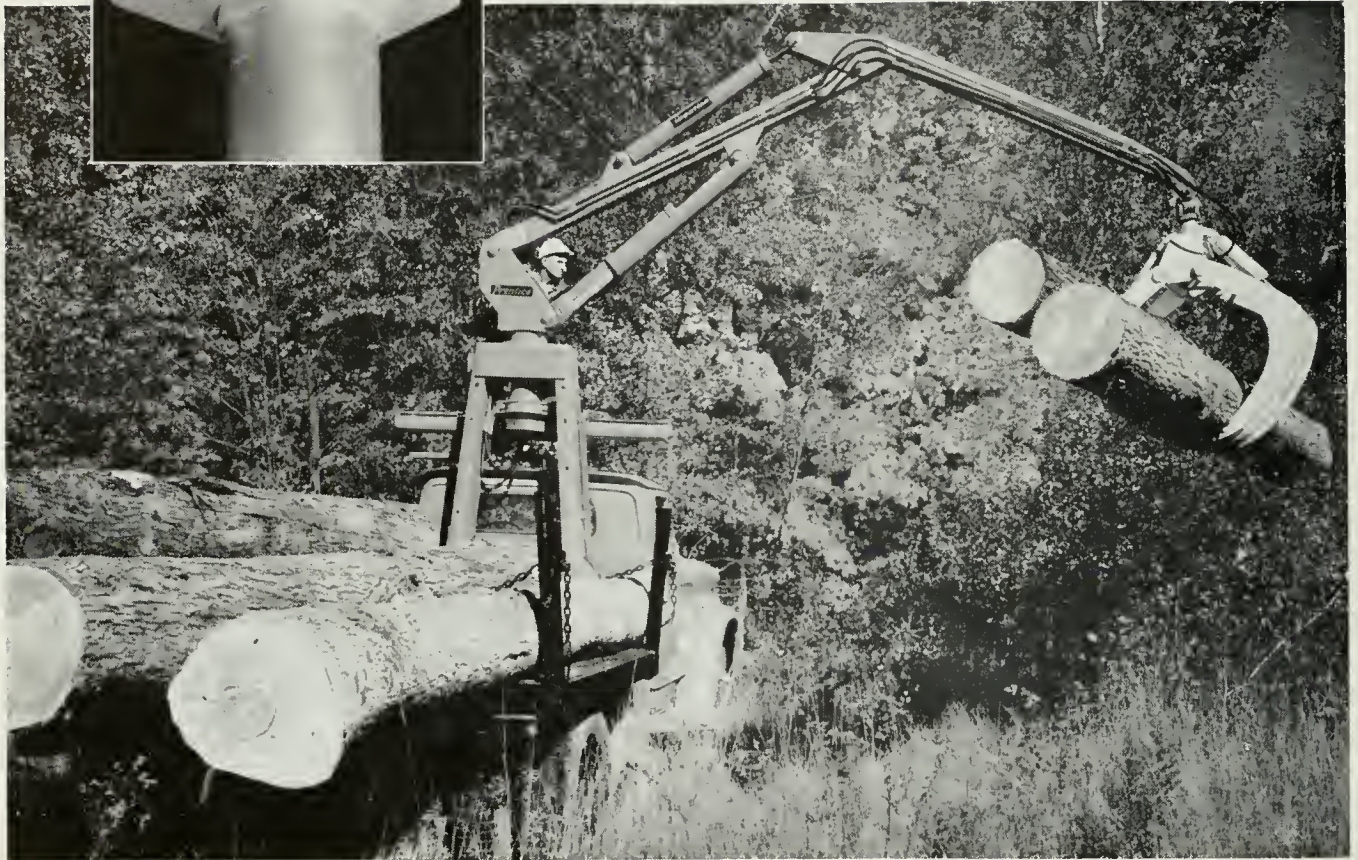

## **FORGED... to end field failures**

This forging forms the critical stress-bearing segment of the turnpost on which a rugged hydraulic loader rotates. It must withstand the sudden high-magnitude stresses transmitted by the 17-foot boom, even in the bitter cold of northern winter logging operations. It replaced a less dependable part that had caused costly breakdowns in the field. By converting to forgings, the manufacturer ended turnpost failures.

Why did the designer look to forgings for superior strength and reliability? Because forged parts start with refined metals, uniform throughout. By hot-working this superior stock between precision dies in forging hammers or presses, the structure of the metal is improved even further. That's why forgings offer unique opportunities to improve strength-weight ratios and reduce production costs.

Forged parts withstand the landing impact of jet aircraft, yet are light and strong. They help restrain the tremendous temperatures and pressures involved in modern missile technology; improve the performance of vital automotive parts. Forgings enhance the safety factor of our high-speed world.

Research projects sponsored by the forging industry and its suppliers will increase even further the ability of forgings to endure the extremes of temperature and the greater stresses inherent in the engineering challenges of tomorrow.

Be better informed about the advantages of forged parts. Write for documented case studies of forged parts converted, at a saving, from less satisfactory higher cost processes. Address: Drop Forging Association, Dept. E-2, 55 Public Square, Cleveland 13, Ohio.

*For more information, see our 4-page, full color advertisements in these magazines: MACHINE DESIGN, DESIGN NEWS, STEEL, MATERIALS IN DESIGN ENGINEERING and AUTOMOTIVE INDUSTRIES.*

*When it's a vital part,  
design it to be*





# Metallurgical Engineering

As Metallurgical Engineering students we again feel that we have one of the most interesting displays to be found at Engineering Open House. Our displays range from such old standbys as the rolling mill, the tempering exhibit and the zinc alloy to last year's third prize winner, the powder metallurgy display. One of our other exhibits in which we are sure you will be interested is the electron microscope used to detect minute flaws and dislocations.

Metallurgy at the University of Illinois is a rather small department on the undergraduate level although our graduate program is large and highly regarded throughout the country. Our classes are small and a very close association is developed between faculty and students.

Examples of the intradepartment camaraderie are the faculty-student bowling competition, softball game, and picnic as well as the senior-junior basketball game. Few other departments develop this cooperation which is also evidenced by large faculty turnouts at monthly meetings of our student society (Mineral Industries Society).

The undergraduate student may elect two options, research or production. Most students elect the production option choosing to take a large core of metallurgy courses in preparation for industry. Many later go on for advanced degrees. The research option requires more math and physics and demands graduate study in preparation for a career in research. It is interesting to note that about twice as many

metallurgy students (by percentage) go on to graduate study as do students in other fields of engineering.

The reason for this is that the primary interest of the metallurgist is in materials rather than in machines. This implies a basic knowledge of the materials themselves as well as their properties and uses.

Some typical problems a metallurgist might face include: operation of a turbine at higher pressures and temperatures, design of a nuclear power station, development of new alloys, or seeking a commercial use for a new material.

Visit the Met. Lab., ask the students what they enjoy about metallurgy, and enjoy the exhibits they have set up for you. ◆◆◆



Students in Metallurgical Engineering are required to take several laboratory courses. Several students are shown doing metallographic work in one of the metallurgical laboratories.

The diversification of engineering processes keynotes the Mechanical Engineering Department's program. The curriculum provides training in the basic courses of science, mathematics, design, energy conversion, and engineering fundamentals, while providing the student with an acceptable background in the social sciences and humanities. Technical electives during the junior and senior years permit students to apply previously learned fundamentals to the area in which he is most interested—heat and power, machine design, production, research, or air-conditioning and refrigeration.

### Displays and Facilities

By presenting the theories and practices of the generation, transmission, and utilization of energy as well as the basic design of machine elements, the Mechanical Engineering student displays at the 1963 Open House will utilize the modern educational facilities available . . . ranging from the operation of power equipment in the M. E. Lab to the solution of design problems on a Heathkit Analog Computer. Included with the mechanical engineering displays will be displays by Industrial Engineering students showing product and process planning, work methods and measurements, and the coordination of these activities with plant layout and material flow.

The facilities offered for undergraduate study can be shown best by briefly outlining the equipment displayed in this year's Open House.

Of prime interest in the Mechanical Engineering Laboratory will be the utilization of steam generated at the university-owned Abbott Power Plant. This steam will drive a variety of prime movers such as General Electric turbines and (for the last time) the Allis-Chalmers steam engine, which provided electricity at the St. Louis Exposition of 1903. Also in operation will be the G. E. Educational Power Plant, which contains a turbo-generator unit simulating the actual operation of a conventional steam generating power plant. Other units on display will include air compressors, pumps, air-conditioning equipment, thermoelectric cooler-generator, and the operation of a Freon-12 refrigeration cycle.

The Internal Combustion Laboratory will demonstrate engine testing and different modes of Internal Combustion engine operation. In operation will be four multi-cylinder engines, including the Falcon, Valiant, and Caterpillar Diesel. Also in operation will be the single cylinder, variable compression ratio, Co-ordinated Fuel Research engine used in universities and fuel research centers throughout the country. Experimental fuel ignition apparatus,

# Mechanical and Industrial Engineering

including one of the two adiabatic compression machines in operation in the world today, will also be on display.

The Foundry exhibit will depict a typical foundry in actual operation. Included in these processes will be molding, core making and baking, melting, pouring, and production finishing processes. Visitors touring the foundry on Friday will see iron castings poured from the cupola, and those on Saturday will see aluminum poured and cast from gas-fired kilns.

In showing the design aspect of the mechanical engineering profession, departmental displays involving basic machine elements such as gears, clutches, transmission shafts, cams, and bearings, will be run in conjunction with the Heathkit Analog Computer.

Exhibits in the machine shop, welding, and heat treatment labs complete

the general survey of the facilities available. The operation of such machines as lathes and gear turning machines will be demonstrated in the machine shop. Displays of tools and different metal chip formations will also be on exhibit including the traditional demonstration of drilling square and hexagonal holes.

In the welding lab, demonstrations of flame cutting, flame welding, arc welding, resistance welding, friction welding, and metal spraying will be shown.

The heat treatment lab will show such tests as those for hardenability and ductility, and others necessary to adequately specify metal properties. Crystalline structures will be observed through microscopes and compared with theoretical lattice structures. The program will be rounded out by a general tour of the lab noting metal research facilities available. ◆◆◆

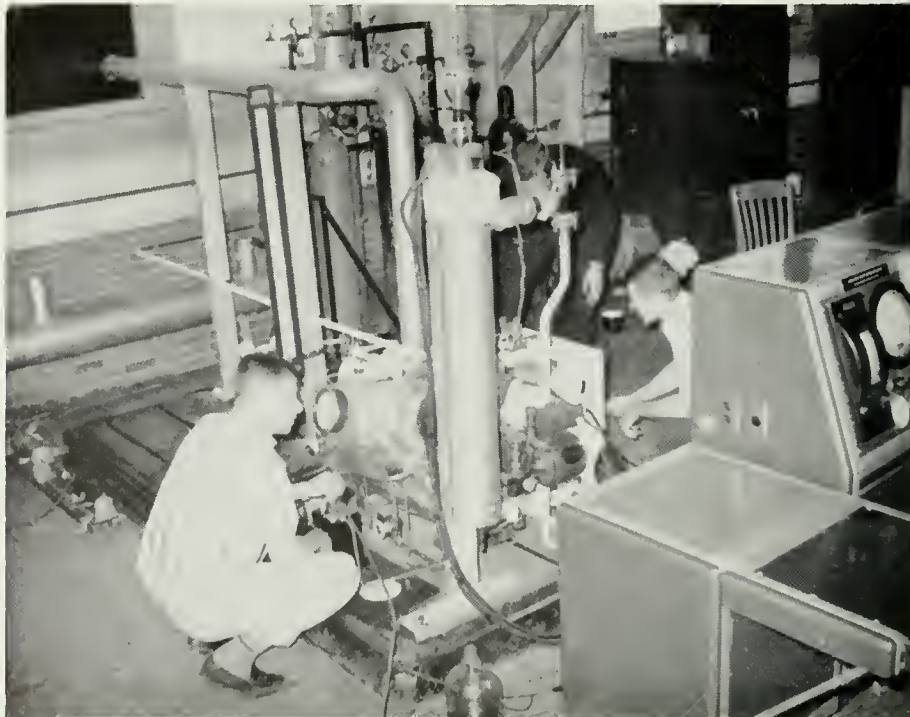

Figure 1. As part of the practical application of the theory taught in the classroom, several Mechanical and Industrial engineering students are shown running tests on the adiabatic compression machine in the Internal Combustion Engine Laboratory.



## WHY DU PONT NEEDS TECHNICAL MEN



Right now Du Pont needs many new mechanical, electrical, civil, chemical, instrumentation, industrial and systems engineers, along with chemists, physicists and mathematicians.

The reason why is very simple: Du Pont manufactures and sells more than 1200 products. And new ones are being developed every day.

Take DYCRIL® Photopolymer Printing Plates, pictured above. We started producing them in 1961. But we had been working on them since 1948. Between these two dates we spent \$10 million on research and development. Hundreds of top-flight technical men spent thousands of hours making DYCRIL commercially acceptable.

And with DYCRIL, as with all of our products, it will take a continuing flow of man-hours to make sure that it is manufactured in sufficient quantity—and of optimum quality—to satisfy growing customer demand.

You can see that, with hundreds of diverse products being produced in many plants across the nation, technical men—many of whom were in college, like yourself, just a few years ago—shoulder big responsibilities.

If you're a technical man, and a challenging future

in industry appeals to you, write us. Use our coupon. You'll receive information about employment opportunities at Du Pont, and, if you like, about DYCRIL Photopolymer Printing Plates.



**BETTER THINGS FOR BETTER LIVING...THROUGH CHEMISTRY**

An equal opportunity employer

E. I. du Pont de Nemours & Co. (Inc.)  
Nemours Building, Room 2531-3, Wilmington 98, Delaware

Please send me the literature indicated below.

- Du Pont and the College Graduate
- Mechanical Engineers at Du Pont
- Engineers at Du Pont
- Chemical Engineers at Du Pont
- Information about DYCRIL

Name \_\_\_\_\_

Class \_\_\_\_\_ Major \_\_\_\_\_ Degree expected \_\_\_\_\_

College \_\_\_\_\_

My address \_\_\_\_\_

City \_\_\_\_\_ Zone \_\_\_\_\_ State \_\_\_\_\_

Presently there are sixty students enrolled in the undergraduate Engineering Mechanics program. With a professorial staff of thirty-three and a graduate school of seventy students, the undergraduate is assured a rich environment for study and individual attention by the faculty.

Engineering Mechanics is a rigorous curriculum stressing the fundamentals of physics, mathematics, and engineering science. The program is designed to give students an extensive theoretical background to aid him in future research and developmental work. Several E. M. students obtain valuable research experience working as assistants in the various laboratories of Talbot Laboratory.

During his senior year each student is required to do a research project emphasizing the synthesis of subject matter covered in dynamics, mechanics of materials, nature and properties of materials, fluid mechanics, electricity and magnetism and heat transfer. This research course, T. A. M. 294, teaches students the proper approach to a practical problem and the limitations of theory in solving such a problem. The course is given particular emphasis by the department and the best possible supervision and facilities are offered. Subjects studied last year included "Cyclic Deformation and Rolling Resistance of Perfect Plastic Spheres," "Effect of Plate Thickness on the Stresses in the Plane of a Crack," "A Study of Dislocation Patterns Near a Cleavage Crack in Titanium Fluoride at Low Temperatures," "Cycle Dependent Creep," "Forced Vibrations of a One-Dimensional Non-Linear Magnetic Spring," and "Effect of Launcher Stiffness on Missile-Launcher Response."

The high school student is often dubious as to what an engineer is and what he does. To become an engineer one must first understand certain principles of science and mathematics and their applications to a particular field. For example, in the field of vibrations the student must first obtain an understanding of differential equations. Such a course provides the student with mathematics capable of describing vibratory motion; the situation is somewhat analogous to the solution of word problems by high school algebra. After studying differential equations, the student is prepared for a course in the specific application of the equations to vibratory bodies, mainly to idealized models such as simple springs. This knowledge is the first element of becoming an engineer.

Applications to actual situations are the remaining necessities. Perhaps the trained engineer will be asked to design shock absorbers to dampen vehicle vibra-

# Engineering Mechanics

tions, such as those resulting from hitting a bump in the road. The engineer will find that he cannot describe exactly the spring effects with the mathematics available to him. He must mentally simplify the situation and make an idealized model which closely approximates the actual situation. From this model he can derive his solution. The judgement required in the adapting of an idealized model is one reason why engineering is often referred to as an art.

What an engineer does is most certainly not limited to the study of fluids, dynamics, plasticity, elasticity, photoelasticity, and material behavior. These

fields are all somewhat inter-related, and the student is given an introduction to each. Upon achieving his B. S., the graduate is quite prepared to enter industry. Recent graduates are now at firms such as North American, Allison, McDonald, Boeing, Douglas, Bell Laboratories, General Electric, ACF Industry, and IBM, to mention only a few. Many students, however, prefer to enter graduate school for specialization in a particular field.

Prospective students seeking more information about the Engineering Mechanics curriculum are encouraged to write: 212 Talbot Laboratory, Champaign, Illinois. ◆◆◆

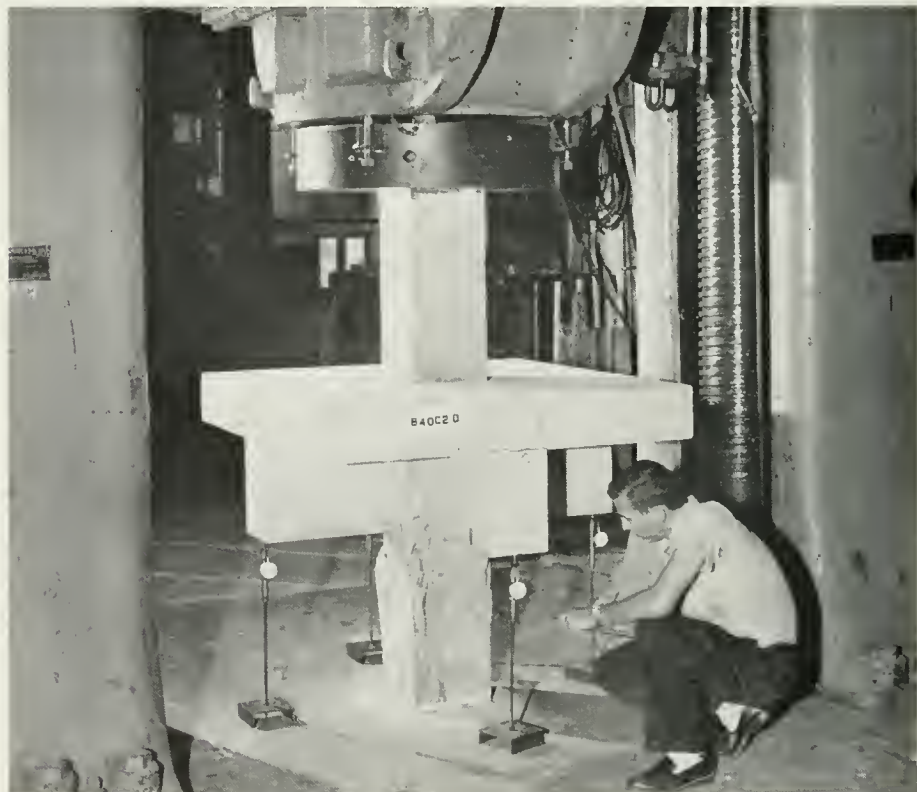

Figure 1. A graduate student is examining the failure in a reinforced concrete specimen. The specimen was loaded by the partly visible machine, which can exert 3,000,000 pounds of compression or expansion.



# Ceramics Engineering

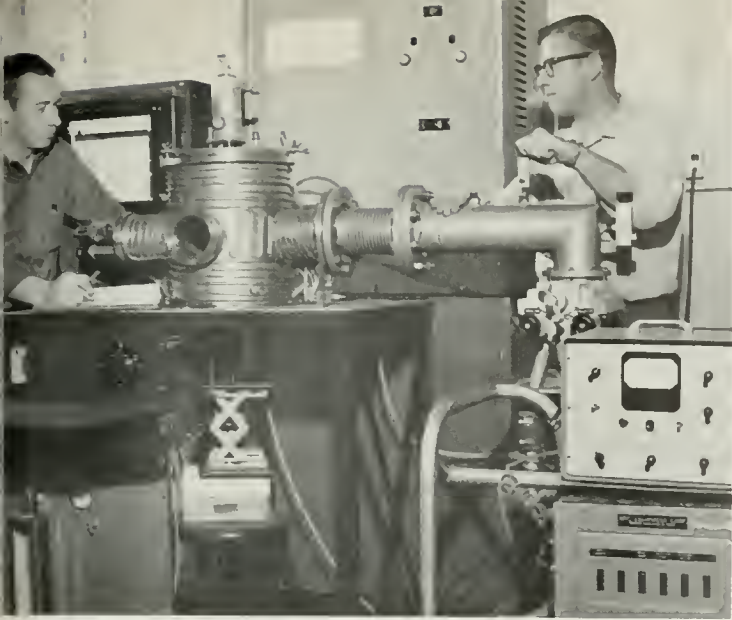

Figure 1. Research staff in the Ceramic Engineering High Temperature Technology laboratory assemble an induction-heated cell used for thermal conductivity, ablation transpiration and diffusion studies of aerospace materials to as high as 5000 degrees F.

Ceramic Engineering is at once the oldest and the newest of the engineering sciences. For, while it began with the ancient discovery that, through fire, clay could be used to make durable and useful containers, it has expanded to such an extent that now it is literally leading the world into tomorrow by providing such vital products as the nose cones of space vehicles and the fuels for nuclear reactors.

But just what are ceramic materials and what is ceramic engineering? In a very broad sense, ceramic materials are those inorganic, non-metallic materials which are subjected to elevated temperatures during either their processing or end use. And, in general, ceramic engineering is simply the scientific adaption and processing of these materials to serve a practical purpose.

## Some Things to See in Ceramic Engineering During The Weekend

Many of the applications mentioned above and many others will be illustrated by exhibits in the Department of Ceramic Engineering during the Science and Engineering Weekend May 10 and 11. Please make it a point to include a stop in our department in your weekend plans—we promise that what you see will be of interest. But just what are some of the exhibits you will find in Ceramic Engineering? A few of the displays are described below.

The compressive strength of ceramics is strikingly illustrated by one demonstration which many people (including ceramic engineers) find hard to believe. An ordinary commercial spark plug insulator is placed on an  $\frac{1}{8}$  inch

thick steel plate and hydraulically loaded. Soon the unharmed tip of the insulator is seen protruding through the plate through the hole it has punched. This is one demonstration you have to see to believe—and even then you may have doubts.

Another display shows the application of glass to the new field of fiber optics. Specially processed glass fibers are collected together in a flexible bundle which transmits light even though the bundle is bent around corners, looped, or even tied in knots. Still other fiber optic devices not only transmit light, but clear and undistorted images as well. Although we don't recommend using them to read a newspaper, it can be done.

A more theoretical but equally interesting exhibit illustrates the effect of heating a ferroelectric ceramic material beyond a certain temperature, known as its Curie temperature. You will be able to bring a crystal of barium titanate to this critical temperature and, by means of a special microscope, actually see the effects of the complete rearrangement of the atoms within the structure of the crystal.

But perhaps your interests lie with the industrial applications of theoretical concepts. If such is the case, other displays will attract you. One of these is a model of a plant for the porcelain enameling of sheet steel, which shows how many common products are manufactured—including the kitchen sink. Or perhaps you would like to see how the crown of a steel-making open hearth furnace is made, or the various ways of measuring and controlling temperatures high enough to melt or vaporize most materials.

If you are a "do-it-yourself" person, you may want to actually measure the temperature of a kiln operating at temperatures over a dozen times that of boiling water or produce a high voltage spark by squeezing a ceramic crystal.

These are just a few of the many things to see and do in the Department of Ceramic Engineering during Science and Engineering Weekend. Whether you are a high school student deciding on a field of study or a casual observer, we guarantee that you will enjoy your visit to our department.

## What Does Ceramic Engineering Mean to Me?

From the time you fill your bowl with breakfast cereal to the time you switch off the light at night, you are surrounded by ceramic products and products made possible only by ceramics.

*(Continued on Page 51, Col. 1)*

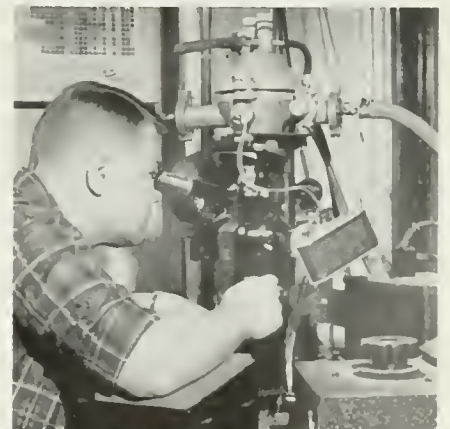
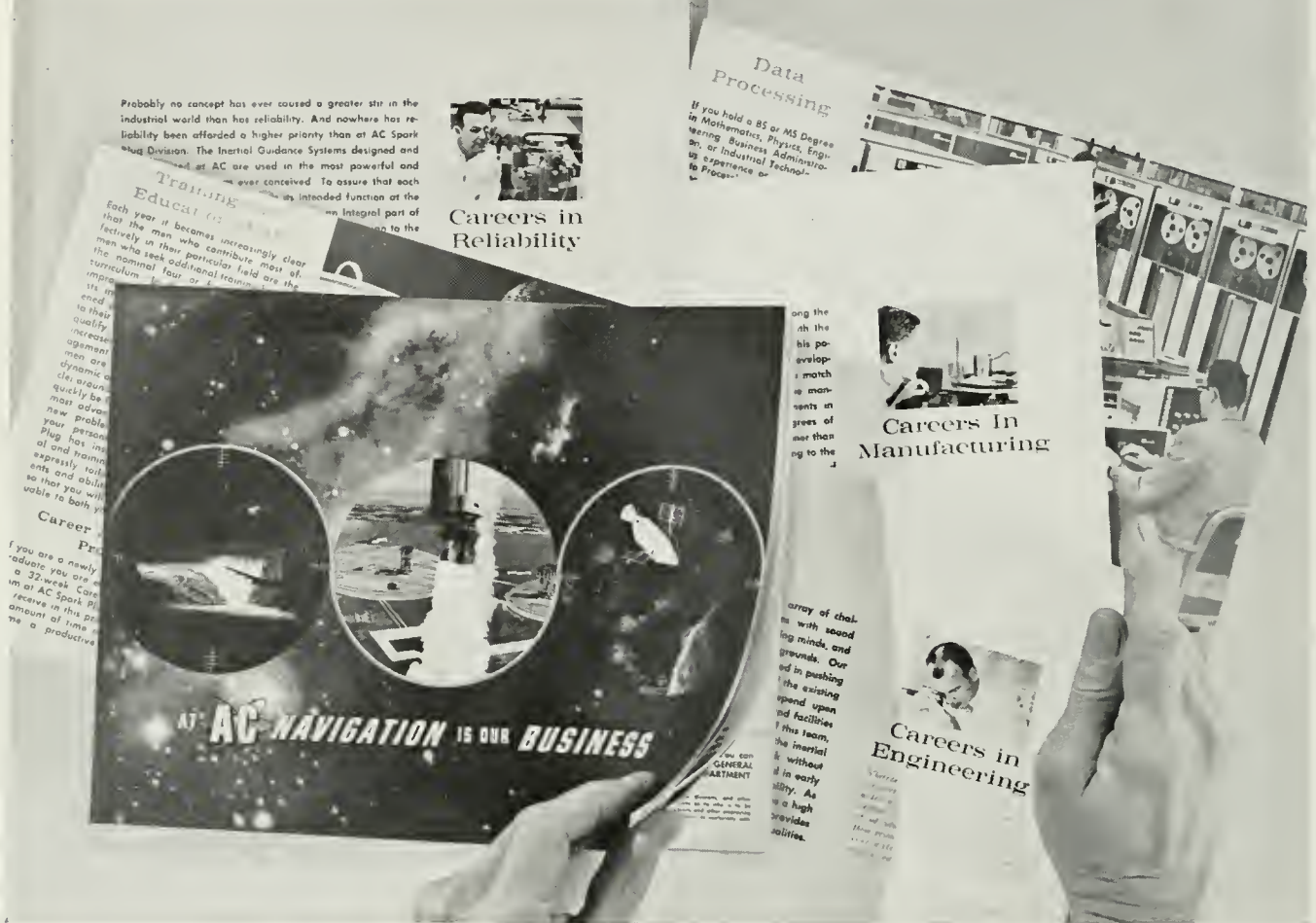

Figure 2. High temperature microscope used in Ceramic Engineering Department to study changes in microstructure of materials during heating to high temperatures.

SEND FOR THIS FREE AC OPPORTUNITIES BROCHURE



**SCIENTISTS, ENGINEERS—GIVE YOUR FUTURE A FINAL EXAM**

Put AC to the test, and you'll come up with the right answer to your future. AC Spark Plug, the Electronics Division of General Motors, is one of the leaders in the field of design, development and production of Inertial Guidance and Navigation Systems. Current projects include the APOLLO Navigation-Guidance System, TITAN II and THOR Inertial Guidance Systems, B-52 (C&D) Bombing Navigational System, POLARIS gyros and accelerometers.

Challenging projects are available in Milwaukee, Los Angeles and Boston for MS and PhD candidates with interests and academic backgrounds in the inertial guidance-navigation field.

Milwaukee—BSEE, ME, or Physics and Math graduates joining AC are offered a 32-week Career Acceleration Program which moves them rapidly into an actively productive position. The two-phase program consists of: PHASE I . . . Eight weeks of formal engineering classes in the areas of: Servo-Mechanisms • Semi-Conductor Technology • Theory of Inertial Guidance • Related Inertial Navigation Topics.

PHASE II . . . Actual work in the organization's three main technical areas: Engineering • Reliability • Operations. Following this training period you will be reassigned to

your original department in Design, Development, Manufacturing or Reliability.

Boston—Advanced Concepts Research and Development On-the-Job Training Program—AC's Boston Laboratory is engaged in development of navigational systems for manned aircraft, ballistic missiles, and space vehicles.

Los Angeles—Advanced Concepts Research and Development On-the-Job Training Program—AC's Los Angeles Laboratory is occupied with advanced guidance research for space vehicles and ballistic missiles, plus research in special purpose digital computers.

CONTACT your College Placement Officer regarding a General Motors-AC campus interview, and send for the informative brochure, "At AC, Navigation is Our Business."

For your Free copy of "AT AC, NAVIGATION IS OUR BUSINESS" fill out coupon and send to:

Mr. G. F. Raasch  
Dept. 5753, AC Spark Plug Division  
Milwaukee 1, Wisconsin

NAME \_\_\_\_\_  
STREET \_\_\_\_\_  
CITY AND STATE \_\_\_\_\_  
SCHOOL \_\_\_\_\_  
DEGREE \_\_\_\_\_  
AVAILABILITY DATE \_\_\_\_\_



AC SPARK PLUG  THE ELECTRONICS DIVISION OF GENERAL MOTORS  
MILWAUKEE • LOS ANGELES • BOSTON • FLINT • An Equal Opportunity Employer





## Life sciences study effects of long range space travel

The life sciences group at The Garrett Corporation is concerned with the reaction of living organisms to their environment, and the development of environmental systems to support such organisms.

Intensive investigation is now being conducted at Garrett in all major areas of the life sciences—microbiology, neurophysiology, psychology, biochemistry, biophysics and related areas—to study the relationships of man to his environment in extended space travel. These studies vary in scope from determining the effects of near vacuum conditions on labora-

tory subjects over long periods of time, to definitively evaluating the effects of re-entry acceleration on human beings.

Garrett also designs, develops and manufactures environmental control systems for this country's major manned spacelight programs, including Project Mercury, Gemini and Apollo.

For information about other interesting projects and the many career opportunities with The Garrett Corporation, write to Mr. G. D. Bradley in Los Angeles. Garrett is an equal opportunity employer.



**THE GARRETT CORPORATION** • AiResearch Manufacturing Divisions • Los Angeles 9, California • Phoenix, Arizona • other divisions and subsidiaries: Airsupply-Aero Engineering • AiResearch Aviation Service • Garrett Supply • Air Cruisers • AiResearch Industrial • Garrett Manufacturing Limited • Garrett International S. A. • Garrett (Japan) Limited

# Architecture

A career in architecture offers an enormous range of professional activity, from the design and construction of individual buildings to large scale planning and design of cities. Since the dawn of civilization, man has sought a spiritual satisfaction in the molding of his environment beyond the solution of practical problems of protection from the elements and the arrangement of spaces to accommodate the many different functions of living and working. For this reason the architect has always been thought of as both an artist and a master of building technology. In fact the word architect, from Greek, (archi = highest, tect = master technician) implies a responsibility for both the beauty and practicability of buildings, either as isolated structures or in the total design of communities.

In addition to a wide variety of building sizes and groupings as well as a variety of functional types, such as schools, churches and houses, a career in architecture presents choices as to specialization in architectural design, structural design, production of working drawings and specifications, supervision of construction, architectural research, manufacturing of building prod-

ucts and many other aspects of the broad disciplines of man-made environment. Opportunities for the practice of architecture are wider than ever before in all types of offices, from one-man consulting services to very large firms of several hundred. Of course it is in the larger firms that most of the newly developing activity in urban renewal is found, but many small offices continue to prosper in an atmosphere of very personal service to individual clients.

There is every indication that the future role of the architect will be of even greater breadth of scope, keeping pace with immense increases in population and the resulting need for technological advance. There is, as well, every reason to believe that society, through better education, will demand designs of higher quality and greater beauty, especially in relation to the city as a whole.

Architectural education, at the University of Illinois as well as in most other major universities throughout the world, is geared to these present and future needs of the architectural profession. The two-fold requirement of broad cultural background and high technical competency is met by a five-year curriculum leading to a Bachelor of Archi-

ture Degree in which emphasis shifts from basic studies in mathematics, drawing, visual fundamentals, physics and mechanics to greater concentration in various architectural disciplines of design, history, construction, and structural theory.

Beyond the B. Arch. Degree, young architects must work for three years in a registered architect's office before they may take the State Board Examination for a license to practice architecture. Many continue advanced studies in graduate schools in which the programs lead to greater competency in definitive design, urban design, advanced studies in history, construction, and structural theory. There is a strong trend to increase the number of years of architectural education in response to the mounting pressure to know and understand the new resources of materials and technology that are constantly developing and to meet services that are expected of the architect.

All of this combines to lend more comprehensive an aura of excitement and opportunity to architectural practice that is most gratifying in its personal satisfaction as well as in its contribution to human progress. ◆◆◆

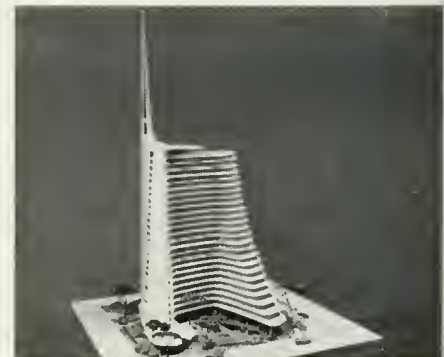

Figure 1. A career in Architecture offers an opportunity to design individual buildings as well as groups of buildings. As depicted by these pictures, architects are answering the public's demand for better quality and more beauty in the man-made physical aspects of their environment.



## Ceramics . . .

(Continued from Page 47)

The dishes in your cupboard, the sink in which you wash them, and the light bulb and the insulators in its switch and socket are all ceramic materials. These are rather obvious, but did you realize that the sidewalk in front of your house, the hundreds of tubes, capacitors, resistors, and magnets in your TV set are also ceramic products? Or that your car wouldn't run if it weren't for its ceramic insulated spark plugs? In fact, if it were not for a certain class of ceramic materials called refractories you wouldn't even have a car since your car and all other steel articles begin as a pool of molten metal in refractory containers. And yet this is just one aspect of the vast field of ceramic engineering.

The field includes all products made of glass, which range from ordinary window glass and fiber glass curtains to certain special types of glasses used as the radomes on guided missiles and flexible glass rods which permit doctors to actually see and examine the internal organs of a patient without surgery. Other ceramic products have such lowly but important functions as carrying sewage from your home, while still others act as heat shields to insure that vehicles may return safely from space. A complete list of the applications of ceramics would be virtually endless.

### A Career in Ceramic Engineering

Now that you have an idea of the many ramifications of ceramic engineering you may wonder what sort of work is done by ceramic engineers. As you may suspect from the diversity and significance of their field, ceramic engineers are sought by a wide variety of industries. Of course they are in demand for the operation and management of companies dealing exclusively with ceramics, such as glass, refractories, whitewares, porcelain enamels, electronic materials, and the like. However, just as great a need for ceramic engineers exists in such fields the steel, aerospace, electronic, and nuclear power industries as well as most technical governmental agencies and a host of other areas through which ceramic engineering directly contributes to the advancement of our technological society.

If this short article concerning a field of engineering you may not be familiar with has aroused your curiosity, please make it a special point to stop by our displays and meet our students and staff. You will find exhibits and demonstrations illustrating some of the courses in Ceramic Engineering and many people willing to answer your questions and discuss your plans with you at our information center. We in the Department of Ceramic Engineering are looking forward to seeing you during Science and Engineering Weekend. ♦♦♦

# Key Programs at **NORDEN** keep your career in motion

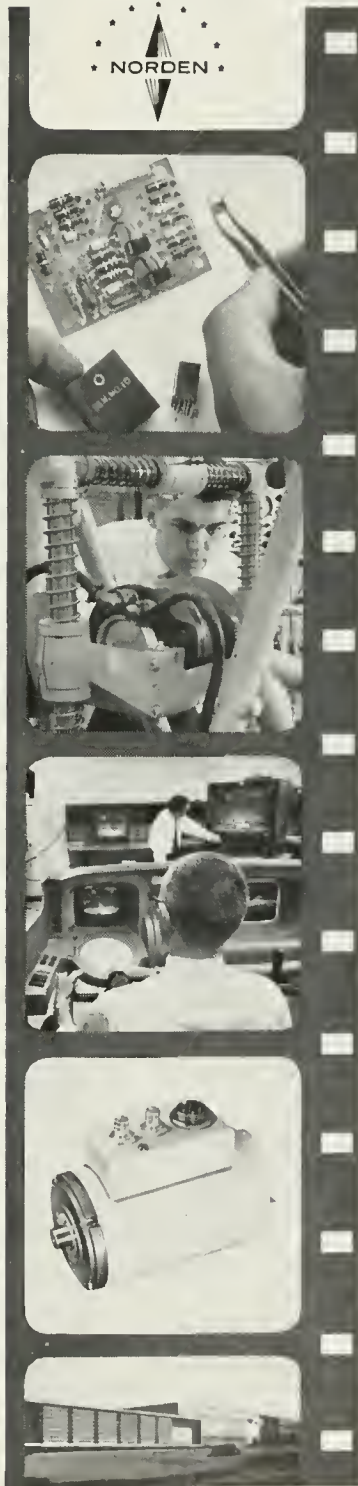

Norden's advanced programs give you a genuine "ground floor" opportunity to develop your talents, and to help bring projects like these to successful completion:

### Molecular Circuitry

Norden has developed integrated crystals which functionally replace conventional circuits. The crystal held in the tweezers performs the same function as the larger and earlier miniaturized components shown here.

### Inertial Platform

Norden's inertial platform is the heart of inertial navigation systems for missiles, space vehicles, surface vessels, aircraft and submarines. It measures only 8" x 10", weighs 20 pounds and maintains vehicle stability regardless of heading, pitch or roll.

### Contact Analog

Norden's contact analog display provides key parameters for submarines, aircraft and manned space vehicles. This system utilizes advanced television and computer techniques developed by Norden.

### Analog Digital Converters

Norden has engineered more than 60 types of analog digital converters for military and industrial use. Shown here is Norden's MICROGON digital encoder which can measure the angle subtended by a ping pong ball at a distance of six miles.

Our new multimillion-dollar facilities make available the laboratories and equipment you'll need.

Norden also offers excellent graduate study programs. And living conditions in Fairfield County are most enjoyable.

If you're an electrical engineer or physicist, and will graduate in January or June, contact your College Placement Officer or write to Mr. James E. Fitzgerald, Technical Employment Manager, Norden.

**Norden** DIVISION OF UNITED AIRCRAFT CORPORATION

NORWALK, CONNECTICUT

An Equal Opportunity Employer





# DEEP SEA DIVERS TO SPACEMEN

**DIVERSITY**—U. S. Rubber makes 33,000 products in 1,200 lines that are used by almost everybody, from deep sea divers to spacemen. In our 22 divisional laboratories or in our Central Research Center, there is a challenge for almost any technical or engineering specialty.

**LEADERSHIP**—Our research sets the pace for the industry. More than 100 years ago, U. S. Rubber made the first manufactured vulcanized rubber product; more than 60 years ago, the first pneumatic automobile tire; more than 40 years ago, the first research on synthetic rubber. Today we contribute our resources and skills to atomic research, to oceanography, to the latest design in space stations, to hundreds of other exciting projects.

**VITALITY**—U. S. Rubber uses to the fullest the professional skills of its 2,000 engineers and research personnel, encourages individual responsibility in an atmosphere of freedom. Our research and development people, in the last five years, have obtained 457 patents, more than our two largest competitors combined.

**OPPORTUNITY**—U. S. Rubber recognizes the importance of our technical staff, knows that the answer to tomorrow's problems is already in the minds of its engineers today. "U.S." rewards individual contributions. Many in our top management started as engineers or technicians with the company. The president of U. S. Rubber is a chemical engineer, several vice presidents hold engineering or technical degrees.

**STABILITY**—U. S. Rubber is one of America's 50 largest industrial companies, with more than 119 years of industrial experience, operating 74 plants at home and abroad. We are a polymer industry with less than half our business in tire manufacturing. U. S. Rubber is one of the nation's largest textile manufacturers and leading chemical producers. "U.S." provides good working conditions for more than 40,000 employees in the United States, another 30,000 abroad.

Inquire about a career with "U.S." Our recruiters will be visiting your campus soon. Sign up for an interview at your Placement Office.



**United States Rubber**





# CIVIL ENGINEERS:

**Prepare for your future in highway engineering — get the facts about new DEEP-STRENGTH (Asphalt-Base) pavement**

Modern pavement engineering has taken a "giant step forward" with DEEP-STRENGTH Asphalt construction for new roads and streets. There is a growing need for engineers with a solid background in the fundamentals of Asphalt technology and pavement construction as new Interstate and other superhighways in all parts of the country are being built with advanced design DEEP-STRENGTH Asphalt pavement.

Your contribution—and reward—in our nation's vast road-building program can depend on your knowledge of modern Asphalt technology. So prepare for your future now. Write us today

**THE ASPHALT INSTITUTE**, College Park, Maryland



THE ASPHALT INSTITUTE, College Park, Md.

Gentlemen: Please send me your free student library on Asphalt Construction and Technology.

NAME \_\_\_\_\_ CLASS \_\_\_\_\_

ADDRESS \_\_\_\_\_

CITY \_\_\_\_\_ STATE \_\_\_\_\_

SCHOOL \_\_\_\_\_

## THE U IN FUTURE

*(Continued from Page 4)*

engineering students and faculty will be at Engineering Open House this May 10th and 11th. One of the purposes of Engineering Open House is to give you a chance to find out more about the branches of engineering.

### Future Non-Engineers:

For you who are NOT INTERESTED in becoming engineers, I hope that it is because you have decided upon another career, or least have narrowed down the fields from which to choose. I hope that your final decision will be the one that is best for you.

We should all strive to learn more about the other professions, in this way we gain a better appreciation and understanding of the other fellow and his problems. Since you are not interested in engineering, you should strive to understand the basic problems in engineering and other fields. In our modern complex civilization, we all depend on each other. If I fail to understand your problems or you fail to understand mine, then we can do little to help each other. This is where I hope Engineering Open House can help you. One of the purposes of Engineering Open House is to inform the public about engineering. This is only one of many ways you can learn about the field of engineering—what has been done; what needs to be done.

Come by and see us May 10th and 11th, and we will try to answer your questions on engineering. ♦♦♦

# The Thunderbird

on The University of Illinois Campus

Pizza

Italian and American Food  
Snack Bar

Imported Beers

Rooms for Private Parties

**FREE DELIVERY**

Call

**344-0017 or 344-0543**

(Continued from page 35)

# TECHNOQUIPS

CE: The folks in the next apartment must have had one heck of a blowout last night. They bellowed and pounded on the walls until 3 a.m.

EE: Did they keep you awake?

CE: No, I was up anyhow, practicing on my drums.

\* \* \*

A truck driver stopped beside stalled Volkswagen on highway: "What's the matter buddy—need a new flint?"

\* \* \*

Mother: "Well, son, what have you been doing all day?"

Son: "Shooting craps, mother."

Mother: "That must stop. Those little things have as much right to live as you."

\* \* \*

When a man sits with a pretty girl for an hour, it seems like a minute. But let him sit on a hot stove for a minute—and its longer than an hour. That's relativity.

\* \* \*

—Albert Einstein

"Hey Dad, I'm home from school again."

"What the devil did you do this time?"

"I graduated."

\* \* \*

"Lips that touch liquor shall never touch mine."

"Your lips?"

"No, my liquor."

\* \* \*

\* \* \*

Sign on bulletin board in front of church in small Wyoming town:

Subject for this Sunday: "Do you know what hell is? Come and hear our new organist."

\* \* \*

Found on a fall registration card of a freshman engineering student: Name of Parents—Mommy and Daddy.

\* \* \*

He was a rather undersized freshman at his first college dance, but despite his smallness and bashfulness, he was sure of himself in his own way. He walked over to a beautiful and over-sophisticated girl and said, "Pardon me, Miss, but may I have this dance?"

She looked down at his small size and lack of fraternity pin and replied, "I'm sorry, but I never dance with a child!"

The freshman bowed deeply and said, "Oh, I'm sorry, I didn't know your condition."

Mother: My son is home from college.

Neighbor: How do you know?

Mother: I haven't had a letter from him in three weeks, and the car is gone.

\* \* \*

Coed: "Don't you kiss me again, you naughty boy."

M.E.: "I won't. I'm just trying to find out who has the gin at this party."

\* \* \*

"Ah wins."

"What you got?"

"Three aces."

"No you don't. Ah wins."

"What you got?"

"Two eight's and a razor."

"You sho do. How come you is so lucky?"

\* \* \*

A small, quiet C.E. ended his phone call, hung up, and then smiled as his dime came back into the slot. Immediately, the telephone rang.

"Are you the man who just made this call?" the operator asked.

"Yes," he said.

"I returned your dime, by mistake. Will you please redeposit it?"

"Sorry," the man said in a typical telephone operator's monotone. "I cannot do this. But if you send me your name and address, I will be glad to send you the dime in stamps."

\* \* \*

The Army reports that its new radar is so sensitive, it can pick up a tank at a distance of ten miles and can identify an enemy soldier three miles away. That is not all. A good operator can tell whether the enemy is male or female. It seems that the hip movement of a woman causes distinctive blips. The question is how are you going to keep the operator's mind on tanks and troops when a hip blip weaves across the screen.

\* \* \*

An instructor asked a new M.E. the purpose of a bolt with a left-handed thread and got this bewildering reply:

"A bolt with a left-handed thread is a bolt which the tighter it's screwed the looser it gets."

\* \* \*

Ag.E.: "I dreamed of you last night."

Coed: (coldly) "Really!"

Ag.E.: "Yes, then I woke up, shut the window, and put on an extra blanket."

at the University under a National Science Foundation grant. These grants allow undergraduate students to enter actively into research work in cooperation with staff members, and at the same time help finance their education. Often, college credit is given for this work.

Perhaps more than any other type of civil engineer, the *Sanitary* engineer is being crowded by the expanding population of the United States. In addition to the over-taxed existing, often old, water distribution and sewage disposal systems, new problems of atomic wastes, stream pollution and air pollution are becoming common.

Civil engineering is indeed a wide and diversified field. However, it is this diversification that should make civil engineering attractive to prospective engineers. Regardless of the project, its geographical location, or its application, some part of civil engineering is likely to be needed for its completion.

Often it is the case that entering freshmen feel that they would like to be an engineer. Generally their capabilities and interest in math and science have created this feeling. But when confronted with the decision to name a particular field the student in general has no real background to base this decision upon. There are exceptions of course but in most cases the decision is made on what they *think* they would like. When making this decision, there are two reasons why civil engineering may be appealing. The first is the wide scope of civil engineering in general. As stated before, almost in any engineering project, civil engineers will be involved at some point. Secondly the new curricula offered by the civil engineering department allows one to gain a basic background in engineering and then choose a specialization or area. This specialization may be in civil engineering or in some other engineering field in which the student has become interested.

The displays and exhibits of the Civil Engineering Department are presented in hopes that the visitors to Open House will gain an insight into the wide scope of civil engineering and will offer a prospective student an idea of what a career in civil engineering will encompass. In addition, we at Open House hope that visitors will make use of the counseling services provided.

Men are available at each exhibit specifically to answer your questions and if any question does arise about the exhibit, be sure to inquire further. It is hoped your visit to Open House is pleasant and that we of the Civil Engineering Department may be of service to you. ♦♦♦



# UNIVERSITY OF ILLINOIS URBANA - CHAMPAIGN

**ENGINEERING CAMPUS URBANA, ILLINOIS**

**ENGINEERING OPEN HOUSE**

AERONAUTICAL ENGINEERING LAB	6.15	HYDROLOGIST LAB NO 2	24
AUTOMOBILE BRAKES-DE LAB	18	MECHANICAL ENGINEERING BUILDING	17
CERAMICS	2.0	MECHANICAL ENGINEERING LAB	15
CHARGED PARTICLE RESEARCH LAB	7	MINING & METALLURGY LAB	19
CIVIL ENGINEERING HALL	9	NUCLEAR RADIATION LAB	21
ELECTRICAL ENGINEERING BUNES	10	NUCLEAR REACTOR	22
ELECTRICAL ENGINEERING BUILDING	4	PHYSICS BUILDING	26
E. Z. RESEARCH LAB	7.8	PHYSICS LAB	14
ENGINEERING RESEARCH LAB	12	SANITARY ENGINEERING BUILDING	25
FIRE STATION	11	TALBOT LAB	3
GASEOUS ELECTRONES LAB	2	TRANSPORTATION BUILDING	16
HYDROLOGY LAB NO 1	23	WOODSHOP & FOUNDRY LAB	5

**SEE INSERT**

**LEGEND:**

- BUS ROUTE
- BUS STOPS
- EXHIBIT AREAS
- PARKING AREAS

**NORTH**

**PHYSICAL PLANT SERVICE BUILDING**

**MEMORIAL STADIUM**

**ASSEMBLY HALL**

**PARKING**

**ST. MARYS**

# Science-Engineering Weekend

## Timetable

### Friday, May 10, 1963

- 7:00 a.m. Illini Union Building opens
- 8:00 a.m. \*Science - Engineering Weekend Bus for visitors begins service with buses at five-minute intervals
- Science - Engineering Information Center opens — Phone 333-1867 — Illini Union Building
- 9:00 a.m. JETS Exposition Commences—Illini Union Ballroom
- 10:00 a.m. Engineering Open House (EOH) commences — all engineering campus Exhibits and Information Centers are open throughout all the Engineering and Architecture Buildings
- Gemini Capsule Launch to Landing Sequence Film every half hour at the Naval ROTC exhibit
- Stress test of Concrete Cylinder with 3 million pounds of force — Theoretical and Applied Mechanics Department—Talbot Laboratory — Hourly after 10:00 a.m., with the exception of noon and 5:00 p.m.
- 10:15 a.m. Distribution of tickets for 2:30 special tours of science departments not participating in Open House begins at Assembly Hall. (West entrance)
- Noon IJAS Exhibits opened to public
- 1:00 p.m. Veterinary Medicine Open House (Vetevue) commences
- 2:00 p.m. JETS judging commences — Illini Union Building
- 2:30 p.m. IJAS special tours (See 10:15 listing above)
- 4:30 p.m. Award certificates distributed for IJAS projects — Assembly Hall
- Distribution of special awards by E.C.I.C. of the American Meteorological Society — Assembly Hall
- IJAS exhibit ends.
- 6:30 p.m. IJAS banquet — Illini Room, Illini Union —closed to public

- 9:00 p.m. JETS closes until 9:00 a.m. Saturday
- Vetevue closes until 9:00 a.m. Saturday
- IJAS social and mixer—Illini Union Building
- 10:00 p.m. EOH closes until 9:00 a.m. Saturday
- Science - Engineering Information Center closes until 8:00 a.m. Saturday
- 10:30 p.m. \*Science - Engineering Weekend Bus service ends for the day
- Midnight Illini Union Building closes

### Saturday, May 11, 1963

- 7:00 a.m. Illini Union Building opens
- 8:00 a.m. Science - Engineering Information Center opens — Phone 333-1867 — Illini Union Building
- \*Science -Engineering Weekend Bus service commences
- 9:00 a.m. IJAS paper session commences — Gregory Hall
- JETS paper session commences — 314 Altgeld Hall
- JETS exhibits open to public — Illini Union Building
- Vetevue commences
- EOH commences
- 11:30 a.m. IJAS Special Awards Assembly — Gregory Hall Auditorium
- 12:00 noon JETS awards luncheon — Illini Room, Illini Union Building — closed to public
- 5:00 p.m. EOH ends
- JETS ends
- Vetevue ends
- Science - Engineering Information Center closes
- 6:00 p.m. \*Science - Engineering Weekend Bus service ends
- Midnight Illini Union Building closes

(See leaflet distributed on campus for revised timetable)



## Kodak beyond the snapshot...



**The powder is vitamin E.** Vitamin E is essential to human life. Also to poultry and livestock. This much is enough for about 200 multivitamin tablets. We make so much of it for the pharmaceutical manufacturers that the operation long ago entered the domain of chemical engineering.

It's an especially interesting kind of chemical engineering, related to the kind we have been developing over the years in our basic business of manufacturing photographic materials.

Vitamin E is in no way a by-product of photographic manufacturing. Only the engineering skills behind it are a by-product. They come out of the maddeningly sensitive nature of sensitized film and paper. Now they are available for the thousands of other fascinating things we make besides vitamin E.

We need more chemical engineers to indoctrinate in our ways. The snapshot business is excellent, but photography has gone far beyond the snapshot and we have gone far beyond photography. *Please drop us a note asking for an explanation of what all this has to do with you.*

**EASTMAN KODAK COMPANY** • Business & Technical Personnel Department  
ROCHESTER 4, N.Y. • We are an equal-opportunity employer.

# Manufacturing Careers Offer Diversity, Challenge and Opportunity

## An Interview with G.E.'s H. B. Miller, Vice President, Manufacturing Services



Halbert B. Miller has managerial responsibility for General Electric's Manufacturing Services. This responsibility includes performing services work for the Company in the areas of manufacturing engineering; manufacturing operations and organization; quality control; personnel development; education, training and communications; materials management; purchasing and systems as well as the Real Estate and Construction Operation. Mr. Miller holds a degree in mechanical engineering and began his General Electric career as a student engineer on the Company's Test Course

For complete information about General Electric's Manufacturing Training Program and for a copy of G.E.'s Annual Report, write to: Personalized Career Planning, General Electric Company, Section 699-06, Schenectady 5, New York.

### **Q. Mr. Miller, what do engineers do in manufacturing?**

A. Engineers design, build, equip, and operate our General Electric plants throughout the world. In General Electric, this is manufacturing work, and it sub-divides into categories, such as quality control engineering, materials management, shop management, manufacturing engineering, and plant engineering. All of these jobs require technical men for many reasons. First, the complexity of our products is on the increase. Today's devices—involving mechanical, electrical, hydraulic, electronic, chemical, and even atomic components—call for a high degree of technical knowhow. Then there's the progressive trend toward mechanization and automation that demands engineering skills. And finally, the rapid development of new tools and techniques has opened new doors of technical opportunity—electronic data processing, computers, numerically programmed machine tools, automatic processing, feedback control, and a host of others. In short, the requirements of complex products of more exacting quality, of advanced processes and techniques of manufacture, and of industry's need for higher productivity add up to an opportunity and a challenge in which the role of engineers is vital.

### **Q. How do opportunities for technical graduates in manufacturing stack up with other areas?**

A. Manufacturing holds great promise for the creative technical man with leadership ability. Over 60 percent of the 250,000 men and women in General Electric are in manufacturing. You, as an engineer, will become part of the small technical core that leads this large force, and your opportunity for growth, therefore, is unexcelled. Technical graduates in manufacturing are teamed with those in marketing who assess customer needs; those in research and development who conceive new products; and those in engineering who create new product designs. I sincerely believe that the role of technical graduates of high competence in the manufacturing function is one of the major opportunities for progress in industry.

### **Q. What technical disciplines are best suited to a career in manufacturing?**

A. We need men with Doctor's, Master's, and Bachelor's degrees in *all* the technical disciplines, including engineering, mathematics, chemistry and physics. We need M.B.A.'s also. General Electric's broad diversification plus the demands of modern manufacturing call for a wide range of first-class technical talent. For one example: outside of the Federal Government, we're the largest user of computers in the United States. Just think of the challenge to mathematicians and business-systems men.

### **Q. My school work has emphasized fundamentals. Will General Electric train me in the specifics I need to be effective?**

A. Yes, the Manufacturing Training Program is designed to do just that. Seminars which cover the sub-functions of manufacturing will expose you to both the theoretical and practical approaches to operating problems. Each of the succeeding jobs you have will train you further in the important work areas of manufacturing.

### **Q. After the Program—what?**

A. From that point, your ability and initiative will determine your direction. Graduates of the Manufacturing Training Program have Company-wide opportunities and they continue to advance to positions of greater responsibility.

*Progress Is Our Most Important Product*

**GENERAL  ELECTRIC**



2e 357  
ILLINOIS  
p. 2

Ill. Coll.

No. 7 - 25c

# TECHNOGRAPH

UNIVERSITY OF ILLINOIS  
MAY 2 1963  
LIBRARY



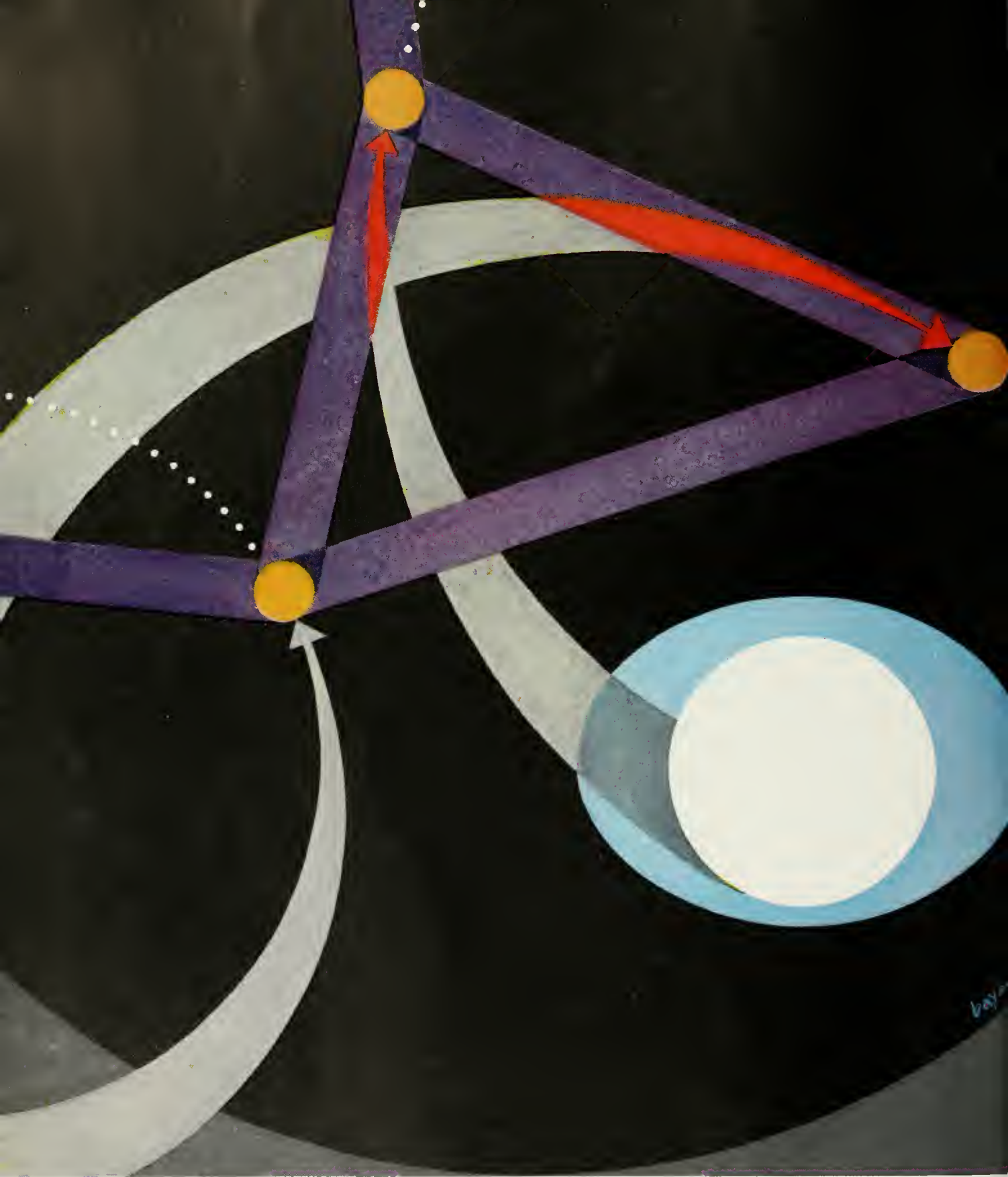

## Westinghouse developments will send words and pictures millions of miles from spacecraft to spacecraft

A beam of modulated light extending into the ultraviolet will some day carry messages, even TV pictures, from one spacecraft to another, or from a spacecraft to a satellite, across the vastness of outer space. This beam will travel 50 million miles with a single watt of transmitted power. It will be so concentrated that interception or jamming will be virtually impossible. A

transmitter about the size of a hatbox will send messages farther than a conventional radio transmitter as big as a steamer trunk. How soon will it be ready? Westinghouse has already demonstrated its feasibility in the laboratory.

Learn more about the diverse and challenging space age research and development projects at Westinghouse, an equal

opportunity employer. Talk with the Westinghouse representative when he visits your campus, or write L.H. Noggle, Westinghouse Educational Department, Ardmore Boulevard and Brinton Road, Pittsburgh 21, Pa. You can be sure . . . if it's Westinghouse.





**Editor-in-Chief**

Wayne W. Crouch

**Business Manager**

Gary Daymon

**Production Manager  
and Assistant Editor**

Stuart Umpleby

**Circulation Manager**

Larry Campbell

**Editorial Staff**

Art Becker  
Thelma McKenzie  
Jim Walters

**Business Staff**

Phillip Johnson  
Wayne Worthington

**Production Staff**

Mike Glowacz

**Circulation Staff**

Bob Bittner  
Paul Gihring  
Diek Kolb  
George Mueller

**Photography**

Joe Figueira

**Secretary**

Kathie Liermann

**Advisors**

R. W. Bohl  
P. Bryant  
W. M. Hudson  
E. C. McClintock

# THE ILLINOIS TECHNOGRAPH

Volume 78; Number 7

April, 1963

## Table of Contents

ARTICLES

To Find Fresh Proof of Life in Space .....	11
The 705 Futuristic Gas Turbine .....	12
Beginning .....	15
Unmonifest Pride .....	21

FEATURES

TECH Says .....	Gary Daymon	4
Co-operative Work-Study Programs in Engineering .....	Dean David R. Opperman	8
Technocutie .....		17
Industry in Pictures .....		18
Brainbusters .....		22
News and Views of the U. of I. ....		20
Technocracks .....		24

MEMBERS OF ENGINEERING  
COLLEGE MAGAZINES ASSOCIATED

Chairman: J. Gale Chumley  
Louisiana Polytechnic Institute  
Ruston, Louisiana

Arkansas Engineer, Cincinnati Coopera-  
tive Engineer, City College Vector, Colorado  
Engineer, Cornell Engineer, Denver Engi-  
neer, Drexel Technical Journal, Georgia  
Tech Engineer, Illinois Technograph, Iowa  
Engineer, Iowa Transit, Kansas Engineer,  
Kansas State Engineer, Kentucky Engineer,  
Louisiana State University Engineer, Louisi-  
ana Tech Engineer, Manhattan Engineer,  
Marquette Engineer, Michigan Technic, Min-  
nesota Technologist, Missouri Shamrock, Ne-  
braska Blueprint, New York University  
Quadrangle, North Dakota Engineer, North-  
western Engineer, Notre Dame Technical  
Review, Ohio State Engineer, Oklahoma  
State Engineer, Pittsburgh Skyscraper, Pur-  
due Engineer, RPI Engineer, Rochester In-  
dicator, SC Engineer, Rose Technic, South-  
ern Engineer, Spartan Engineer, Texas  
A & M Engineer, Washington Engineer,  
WSC Technometer, Wayne Engineer, and  
Wisconsin Engineer.

The Cover: by Bill Smoll

Life On Other Planets

Copyright, 1963, by Illini Publishing Co. Published eight times during the year (Oc-  
tober, November, December, January, February, March, April and May) by the Illini  
Publishing Company. Entered as second class matter, October 30, 1920, at the post  
office at Urbana, Illinois, under the Act of March 3, 1879. Office 215 Engineering  
Hall, Urbana, Illinois. Subscriptions \$1.50 per year. Single copy 25 cents. All rights  
reserved by *The Illinois Technograph*. Publisher's Representative - Littell-Murray-  
Barnhill, Inc., 737 North Michigan Avenue, Chicago 11, Ill., 369 Lexington Ave.,  
New York 17, New York.





## Holding the line . . . for a richer harvest

Boll weevil, codling moth, leaf rollers, thrips and beetles . . . these are only a few of the thousands of insects that chew up millions of dollars worth of farm crops each year. Fortunately, however, they are no match for a new Union Carbide product called SEVIN insecticide. In the United States and many other countries, the use of SEVIN has already saved such staple crops as cotton, corn, fruits and vegetables from destruction by ravaging insects. ▶ You can now get SEVIN insecticide for your own garden as part of the complete line of handy EVEREADY garden products that help you grow healthy vegetables and flowers. SEVIN comes from years of research in Union Carbide laboratories and at an experimental farm in North Carolina where scientists prove out their latest agricultural chemicals. ▶ This is only one area in which chemicals from Union Carbide help improve everyday living. The people of Union Carbide are constantly at work searching for better products that will meet the needs of the future.

A HAND IN THINGS TO COME

**UNION  
CARBIDE**

LOOK for these famous Union Carbide products—SEVIN Insecticide, EVEREADY Garden Chemicals, “6-12” Insect Repellent, LINDE Synthetic Emeralds and Stars, PRESTONE Car Care Products. Union Carbide Corporation, 270 Park Avenue, New York 17, N.Y. In Canada, Union Carbide Canada Limited, Toronto.



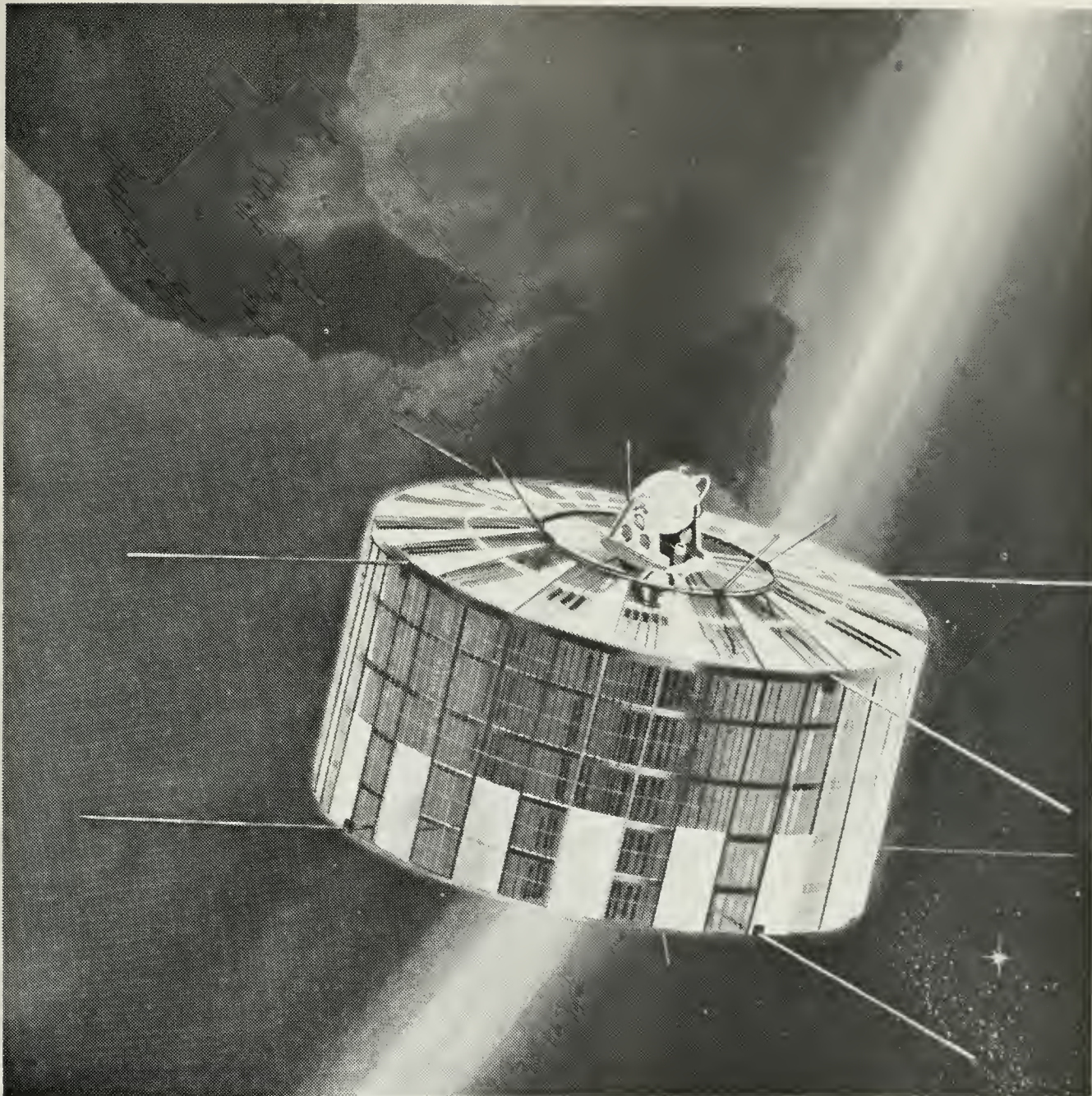

Illustration Courtesy The Martin Company

## Atomic power for outer space

Monsanto... a world leader in chemicals, plastics and petroleum products... has also taken a giant step into the atomic space age. Now broadcasting signals from space is a *Transit* satellite transmitter, powered by an "atomic generator." This long-lived power source is fueled with plutonium 238 processed and encapsulated at Mound Laboratory, which Monsanto Research Corporation, a wholly owned subsidiary of Monsanto, operates for the Atomic Energy Commission.

This achievement is important to *you* because it suggests the kind of future the Monsanto family offers the young engineer of exceptional promise. You'll be joining a

company that's ready and able to move vigorously into new fields. And that means plenty of growing room for *you*... ever-expanding opportunity as your professional interests broaden.

See your Placement Director to arrange an interview when we visit your campus soon. Or write today for our new brochure, "You, Your Career and Monsanto," to Professional Employment Manager, Department EM-5, Monsanto Chemical Company, St. Louis 66, Missouri.



ALL QUALIFIED APPLICANTS WILL RECEIVE CONSIDERATION WITHOUT REGARD TO RACE, CREED, COLOR OR NATIONAL ORIGIN



# Less and Less about More and More

Definition of an Engineer: One who learns more and more about less and less until he knows everything about nothing.

Herbert Hoover would no doubt disagree with this definition (See page 21). TECHNOGRAPH certainly disagrees, and to disprove this definition here is less and less about more and more until you know nothing about everything.

## ISPE-MSPE Convention

"Meet me in St. Louis" is the theme of this year's combined Illinois-Missouri Professional Engineers 1963 Joint Convention, May 3-4, 1963, at the Sheraton Jefferson Hotel, St. Louis, Missouri. Student ISPE members should write E. W. Markwardt, P.O. Box 81, Belleville, Illinois, for information and pre-registration forms. Faculty members are encouraging all students to attend if possible.

## FREE—100 Page Design Manual

TECHNOGRAPH has made special arrangements with the American Sprocket Chain Manufacturers Association for our readers to receive a free copy of the "Design Manual of Roller and Silent Chain Drives." This 100 page, hard-cover, 8½x11 inch book is the only authoritative source of this design data. . . . A "must" for M.E.'s and Ag students.

Included in its contents are: Horsepower Chart and Rating Tables; Application of Chain Drive Design to a Specific Problem; Silent Chain Horsepower Rating Tables per Inch of Chain Width; Sprocket Design; Standard Keys and Keyways.

To get your free copy, just write a brief note to TECH, 215 C.E.H., or telephone 333-1568 (2-5 Mon. or Wed.), TECH will order the book, and it can be picked up in about ten days.

## Technical Writing Books and Articles

A "must" for would-be technical writers is a new book TECHNICAL WRITING by Richard Smith. This \$1.25, 175 page book is one of the "College Outline Series." It is available at the campus book stores, or it can be obtained from the publisher—Barnes and Noble, Inc. The book covers the preparation of manuals, reports, proposals, and articles for both industry and government. The text covers the functions of the technical writer; technical writing style; preliminary steps; the technical manual, report, proposal, and article; the duties of a technical editor; writing the technical film; technical advertising and publicity; the mechanics of the trade; and the future of technical writing. A self-testing section

is included to be used before and after studying the text.

Potential technical writers will also be interested in an article in the May issue of *Electronics World*. "Are You a Potential Electronics Technical Writer" by Cyrus Clickstem discusses the background for technical writing; military, commercial, and general technical writing and the advantages and disadvantages of each; military writer grades; and technical writing jobs.

## Illinois Fifth in Total Number of Engineers

Fifty two thousand (52,000) engineers (an increase of 35% since 1950) are employed in the state of Illinois to place it fifth in the nation. California is first with 124,700 (147% increase over 1950); New York is second with 86,700 (43% increase); Ohio and Pennsylvania are next in line with 54,900 (47% increase) and 53,300 (37% increase) engineers employed. The total rise in engineering employment since 1950 represents an increase four times the growth of total employment and nine times the growth in male employment.

## 1957 Engineering Graduate Salaries

Engineering graduates of the University of Illinois' class of 1957 have increased their salaries 62% in slightly more than five years. The average starting salary was \$477 a month in 1957, and after five years they now earn an average of \$771. Aeronautical engineers with B.S. degrees began highest in 1957 at \$505 a month. Today these men average \$812 but are topped by the electrical engineers who started at \$487 and now get \$857, and by engineering physicists, who started at \$464 and now average \$950.

## Science and Engineering Weekend May 10-11

Don't forget to mark these dates on your calendar. For the first time Science and Engineering weekend will be presented by the joint efforts of the following groups: Engineering Open House; Illinois Junior Academy of Science; The 11th Annual Junior Engineering Technical Society Exposition; and the Veterinary Medicine Open House. For a full program of events see the March issue of TECHNOGRAPH. Extra copies can be obtained by writing TECH and enclosing 25 cents per copy.

Gory Daymon



Exploration of the universe by spacecraft capable of safely transporting men takes vast down-to-earth preparation. That's why Douglas is now building the nation's most modern research and development facility on a 245 acre site in Huntington Beach, California. □ The Douglas Space Systems Center will include a space simulation chamber 39 feet in diameter, capable of housing a complete manned spacecraft. Supplementing this will be a complex of specialized research laboratories. Here, manned space systems will

## MAN-RATED SPACECRAFT

be proved in environments similar to those which will

...A STIMULATING AREA FOR CREATIVE ENGINEERS

exist on orbital, lunar and interplanetary missions. □ Douglas understanding of space problems is a direct result of booster experience and manned vehicle experience with high performance military aircraft.



If you are seeking a stimulating career in the thick of the most vital programs of today and tomorrow, we invite you to contact us. Write to Mr. S. A. Amestoy, Douglas Aircraft Company, 3000 Ocean Park Blvd., Santa Monica, California, Box 600-M. Douglas is an equal opportunity employer.





If you want to specialize in data processing . . .

## YOU SHOULD BE AT COLLINS

Why? Because Collins is taking an entirely new approach — the Microprogramming Technique — to computer design. We're using this technique in combining communication functions—message switching, priority routing, data transmission and conversion— with conventional computer data processing applications. This new Collins concept of what a computer can do opens up a whole new field of programming and design. You'll be able to experiment and explore. You'll have the opportunity to actually participate in logical design. You'll be looking for new ways to use this computer system, new applications in which it can be used, new product development ideas. Talk about ground floor opportunities! We've already sold and are installing these systems in airline and railroad communication networks. But the surface has just been scratched. If you have the qualifications listed at right, we'd like to talk with you. Check with your placement office or write the Collins engineering center nearest you.

A degree in E.E., Math or Business Administration — and a desire to be a data processing specialist — will equip you to take advantage of these ground floor opportunities



Send your reply to:

E. D. Montano  
Information Science Center  
Collins Radio Company  
Newport Beach, California

L. R. Nuss  
Collins Radio Company  
Cedar Rapids, Iowa

C. P. Nelson  
Collins Radio Company  
Dallas, Texas

An equal opportunity employer





## Life support for 14 days in space

The NASA-McDonnell Project Gemini is the major link between Project Mercury and Project Apollo (this nation's first flight to the moon). It will give our space effort vital information on prolonged spaceflight effects and will also be used to test space rendezvous techniques.

Gemini's advanced environmental system will keep the spacecraft's two astronauts comfortable for two weeks of continuous orbital flight. Garrett-AiResearch builds the system that provides a breathable atmosphere, pressurization, temperature control, ventilation and atmosphere purification in the two-man spacecraft and in both

astronauts' suits for the entire flight. AiResearch also supplies the supercritical cryogenic oxygen and hydrogen tankage system for the spacecraft's fuel cell power supply.

This is but one more example of Garrett's proved capability in the design and production of vital systems and their components for spacecraft, missile, aircraft, electronic, nuclear and industrial applications.

For further information about the many interesting project areas and career opportunities at The Garrett Corporation, write to Mr. C. D. Bradley in Los Angeles. Garrett is an equal opportunity employer.



THE GARRETT CORPORATION • AiResearch Manufacturing Divisions • Los Angeles 9, California • Phoenix, Arizona • other divisions and subsidiaries: Airsupply-Aero Engineering • AiResearch Aviation Service • Garrett Supply • Air Cruisers • AiResearch Industrial • Garrett Manufacturing Limited • Garrett International S. A. • Garrett (Japan) Limited

# CO-OPERATIVE WORK-STUDY PROGRAMS IN ENGINEERING

by Dean DAVID R. OPPERMAN

There have been two co-operative work-study programs between industry and the College of Engineering at the University of Illinois since 1956 which have involved a limited number of students. In recent months there has been a renewed interest in co-op programs on the part of industry, and as a result the University of Illinois is expanding its program. One additional company has joined in the program and negotiations are under way with two other companies.

Co-operative work-study programs alternate periods of study in formal college courses with periods of work experience in industry. Co-op programs are not at all new and certain schools, such as the University of Cincinnati, emphasize co-op programs for the entire student body. Two other large mid-western schools with extensive co-op programs are Northwestern University in Evanston, Illinois, and Purdue University at West Lafayette, Indiana.

Approximately 25 undergraduate engineers at Illinois are presently on co-op programs with industry. Because of the expansion of the program it appears that there will be an opportunity for double that number of students to be on co-op programs during the 1963-64 school year. Students who are interested in beginning a program of work and study with industry should start making plans immediately since selections for co-op programs are generally made several months ahead of the time that the student enters his industrial work period.

There are opportunities for high school students to enter a co-op program as well as for students who are currently enrolled in engineering. A typical work-study program will have the student complete his freshman year at college before he enters his period of

practical work experience in industry. Following his first work experience he will return to school and then alternate periods of work and study until his senior year of college studies. Generally the senior year is spent at the university and the student will receive his bachelor of science degree at the conclusion of that year of study. Two typical plans for alternating work and study are shown in the accompanying illustration.

Most co-op programs are flexible within certain limits. Commitments are not binding and can be adjusted to fit the needs of the students or of industry. However, it is hoped that students who enter a co-op program will follow their original curriculum and schedule of studies and work experience as nearly as possible. Since the industrial firms try to keep approximately equal numbers of students in school and at the plant simultaneously, it is apparent that wholesale shifts of schedules could easily disrupt the ability of the company to schedule a meaningful work experience. The work experience ordinarily involves a system of rotation between the various facets of the company's operations so that both the company and the student can become familiar with each other.

Students often wonder whether or not it is wise to enter a cooperative work-study program with an industrial firm. There are many advantages to such an arrangement as well as certain disadvantages. The final decision will have to be made by the individual student based upon his own personal circumstances.

One of the more obvious advantages to the student is that he gains practical work experience during the time that he is studying engineering in college. The theoretical material that the student learns in the classroom may be applied

during his industrial experience. In addition, the student receives valuable counseling and challenging job assignments that will help him plan his future career in engineering.

Salaries paid to students during their work periods are substantial. The McDonald Aircraft Corporation estimates that students on their co-op program may earn as much as \$8,000 during the five years that they are on the program. The National Aeronautics and Space Administration co-op program gives their students progressive salary increases up to a maximum of \$380 per month during the final work experience period. The money that the student earns during these periods of time can be used to help finance his education. The co-op program guarantees certain periods of employment for the student during his education thereby releasing him from the burden of finding a job in industry each summer or remaining unemployed.

The educational experience that the student receives becomes more meaningful through his association with practicing engineers in industry during his college years. The student gains a feeling for his profession by witnessing it in action. To a certain degree, the student gets started on his professional career even before he receives his baccalaureate degree. These kinds of experiences can enrich college studies so that the graduate of a co-op program is in a position to be more useful to the company for which he goes to work.

The advantages enumerated above are offset by a number of disadvantages. Perhaps the most significant disadvantage is that the co-op student is limited in his extra curricula activities which form an important part of the learning experience during the college years. It would be most difficult for a co-op stu-



dent to participate in advanced ROTC training or student tours abroad since he would not have summers available for these activities. In addition, other activities such as glee club, university theatre, varsity athletics, student societies, etc., lose their continuity for the student if he is constantly alternating his period of attendance at the university.

The co-op student loses time toward graduation which can be of considerable economic importance. The average starting salary of a graduate engineer is now approximately \$600 per month. The salary earned during the employment periods in a co-op program should be weighed against the salary lost by delaying graduation.

Students often ask why companies desire to establish co-op programs with the universities. Probably the most significant reason for establishing a co-op program is that it gives the company an opportunity to look over a future employee.

The program establishes a certain relationship between the student and the company which many times will result in the student seeking employment with the company after graduation even though no such binding commitment is demanded of a co-op student. Some companies estimate that they spend at least \$2,000 to recruit each engineer that they hire. An effective co-op program can save an industrial firm many thousands of dollars over a period of time if the company is not forced to recruit on the open market.

Most industrial firms recognize a certain obligation to assist education. This assistance may take the form of scholarships, financial grants to institutions, research grants, or, it may take the form of direct financial aid to students through a cooperative work-study program. There are certain numbers of students who would not be able to attend college if they were not guaranteed employment during their college years. A cooperative work-study program assists students to finance their education by interspersing it with periods of employment and practical work experience in industry.

At present, three employers have active cooperative work-study programs with the College of Engineering at the University of Illinois. They are the Rock Island Arsenal at Rock Island, Illinois, the McDonald Aircraft Corporation at St. Louis, Missouri, and the National Aeronautics and Space Administration Test Facility at Edwards Air Force Base, Edwards, California. Since each of these groups is located in an area where students can continue their education through night school classes, extension courses, or by correspondence, they encourage students to continue their academic work on a part time basis during their employment periods. The courses taken, if properly chosen, can be used toward the bachelor of science degree at the University of Illinois and can help the student lighten his academic schedule.

There are no special qualifications for

entering a cooperative work-study program except that most companies prefer that the student be unmarried and in the upper half of his college class. The companies usually prefer to select their high school participants from the top 10 or 15% of the high school graduating class. The students are never asked to sign any binding commitments to remain on the co-op program for a specified period of time nor are they in any way obligated to go to work for the company after graduation. Women are equally as welcome as men to participate in a co-op work-study program.

Students wishing to secure additional information concerning the cooperative work-study programs at the University of Illinois may write to any of the following people:

Mr. G. H. Nickell  
U. S. Army  
Rock Island Arsenal  
Rock Island, Illinois  
Mr. Scott King  
Training Department  
McDonald Aircraft Corporation  
Box 516  
St. Louis 66, Missouri  
Mr. Gerard W. Herbert  
Training Officer  
NASA Flight Research Center  
Box 273  
Edwards, California

Additional information and application blanks concerning these programs may be obtained from the Office of the Associate Dean, 103 Civil Engineering Hall.

## A TYPICAL WORK-STUDY PROGRAM

### PLAN A

	First Year			Second Year			Third Year			Fourth Year			Fifth Year		
	Fall	Sp.	Sum.	Fall	Sp.	Sum.	Fall	Sp.	Sum.	Fall	Sp.	Sum.	Fall	Sp.	Sum.
Semesters on Campus	1	2	2½		3½		4½			5½			6½	7½	8
Work and Study Periods	S	S	S	W	S	W	S	W	W	S	W	W	S	S	S

### PLAN B

	First Year			Second Year			Third Year			Fourth Year			Fifth Year		
	Fall	Sp.	Sum.	Fall	Sp.	Sum.	Fall	Sp.	Sum.	Fall	Sp.	Sum.	Fall	Sp.	Sum.
Semesters on Campus	1	2		3	4	4½		5½			6½			7½	8
Work and Study Periods	S	S	W	S	S	S	W	S	W	W	S	W	W	S	S

S--Study Period on Campus

W--Work Period in Industry

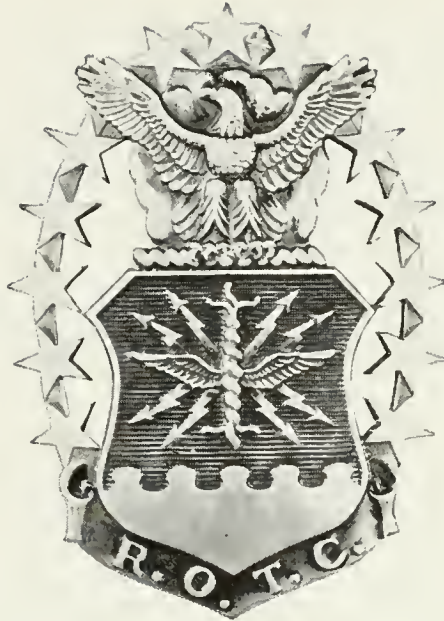

**Missed A.F.R.O.T.C.?**



**Go A.F.O.T.S.!**

These letters stand for Air Force Officer Training School—the gateway to an Air Force career for ambitious college men who didn't have the chance to enroll in AFROTC.

OTS is a tough course. But it's a great opportunity—one that may not always be available. If you're within 210 days of graduation, we welcome your application now. We can't guarantee that we'll be able to in a year.

As an Air Force officer, you'll be a leader on

the Aerospace Team. You'll be serving your country while you get a flying headstart or an exciting career.

The U.S. Air Force is at the forefront of every vital new technological breakthrough of the Aerospace Age. It sponsors one of the world's most advanced research and development programs—and you can be part of it.

OTS is open to both men and women. For information, see your local recruiter.

**U.S. Air Force**



# . . . to Find Fresh Proof of Life in Space

Few scientists expect that in the near future we shall make contact with intelligent life outside the earth, whether Martians or civilizations light years distant beyond the solar system. What is being sought at the moment is simply chemical or biological evidence—beyond what we already may have—that life exists or has existed outside the earth. Discovery of such evidence could come with startling speed, for the National Aeronautics and Space Administration (NASA) plans to make space probes of Mars very soon. Perhaps, before long, “puppet laboratories” can radio back their findings. It may be possible to retrieve samples of matter from Mars or elsewhere before the first manned flight. Thus it becomes urgent to decide how to identify extraterrestrial life—either to settle upon the best existing methods or develop new ones.

Several years ago, after studying hydrocarbons in crude oil and soils and living things, Dr. Warren G. Meischein, chief investigator in the NASA project, proposed that certain alkanes (complex, saturated hydrocarbons appearing in all these materials) are products of life. At that time he suggested using alkanes to investigate the existence of very ancient life on earth.

Instead, however, in 1961 alkanes were employed to discover the first scientific indication that life exists or has existed in space. It was proven that certain molecules within the core of the Or-gueil meteorite resembled molecules made by living things on earth, a strong indication that hydrocarbons within the meteorite were also products of life. Later that year, microfossils of types un-

known on earth were found within the same meteorite. Most resembled in general appearance, but not in structural detail, certain microfossils gathered from sediments throughout the world. The contents of the meteorite are still being widely investigated and their significance argued.

Perhaps these investigations, even before other material from space can be analyzed, may establish that life exists there. In any case, meteorite studies are an important preparatory school for space. The methods and techniques developed while analyzing meteorites may be applied to investigations of Mars, other planets, and the moon. It may not be necessary to capture living organisms or even fossils in order to demonstrate that life has established itself on Mars. Molecules of biological origin, such as the alkanes, may be the best evidence of the prior existence of life anywhere. The fact that molecules are invisible to the naked eye and must be investigated by instruments even has certain advantages. Modern instruments can define the structure of complex molecules with greater precision than the most objective observer can describe what he sees.

Molecules produced by living things are far more widely distributed than microfossils. They are also more stable and thus more reliable. Even the fossilized remains of organisms decay, passing, as Shakespeare said, “through nature to eternity.” But enroute, as the oil industry has learned, living things form compounds which may long outlast them. Sediments, the beds of ancient seas, once held primitive life that has long since vanished without a trace other than the enduring oil.

Dr. Meischein believes that the alkanes are probably the most widely distributed, the easiest to isolate, and the best preserved products of life, on this or other planets. Thus they may offer the best basis for comparison. The NASA project will make it possible to gather additional information about them.

More than one hundred leading American scientists, after an extensive study last year of the nation’s space program, urged that finding life in space should become the first objective. The same group also observed that “chemical principles presumably hold good in all locales.” In other words, whatever course life may have taken elsewhere, its beginning everywhere is probably much the same.

It is not inconceivable that the two greatest of mysteries—how life began and how widespread it may be—are to be solved not separately but together. The subject is of such magnitude and carries such philosophical and theological significance as to inspire an almost religious awe among scientists concerned. A discovery of life in outer space, supporting the meteorite investigations of 1961, would only confirm what many scientists now consider likely—that the whole universe is one vast laboratory of life. Even now we should conduct ourselves circumspectly, taking great care, for example, neither to contaminate Mars with earthly bacteria nor to bring back alien bacteria—remembering that the universe may not be our laboratory alone. ◆◆◆

*Edited from the LAMP, published by Standard Oil Company of New Jersey, Spring, 1963.*

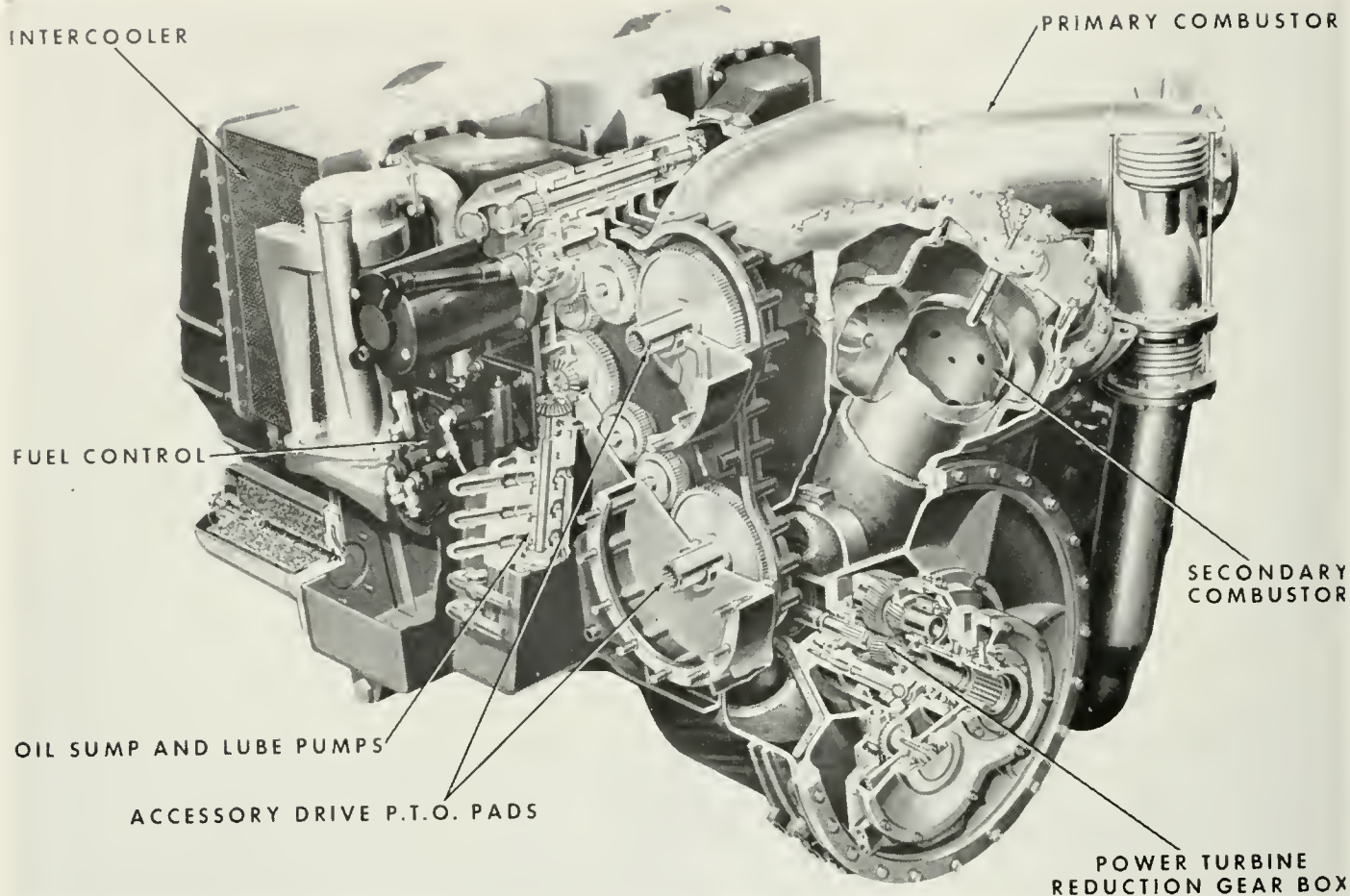

## THE 705

# FUTURISTIC GAS TURBINE

The latest development in gas turbine engines was displayed several weeks ago by the Ford Motor Company. The 600-horse-power supercharged gas turbine was developed under a joint Army-Navy contract and is presently undergoing operational tests.

The unique feature of this new, comparatively light weight engine is supercharging, accomplished with two stages of compression. This allows the engine to use less air, maintain excellent fuel economy throughout its operating range, and employ smaller parts running at high speeds. This principle has always been considered by turbine engineers as difficult to accomplish and has never been attempted by any manufacturer in an engine under the 5,000-hp size. One part, the compressor, spins at 75,500 rpm, rotating the blade tips at supersonic speeds.

Problems such as this lead engineers to claim that without the aid of modern, advanced digital and analog computer techniques, they would not have been able to solve the complex aerodynamic

and control problems encountered in this unique design.

Model 705, the name given the engine, is designed to meet the military's ever-increasing demands for a light, compact, low-fuel consumption engine, and particularly for one capable of consuming many types of fuels.

The Navy's requirements for an advanced gas turbine were based on the needs of future surface antisubmarine warfare craft, hydrofoils, hydroskinners, minesweepers, and amphibious vehicles. The Army's needs are for a power plant for heavy vehicles, particularly tanks, auxiliary generator sets, and a variety of portable power plant applications.

These requirements mean the engine must be rugged enough to operate under field conditions, able to start at sub-zero temperatures, and must operate in a wide variety of adverse environmental conditions.

When it is equipped with snorkel in an Army tank for fording streams, the 705 is designed to run under 10 feet

of water with no damage to its metal parts even though its combustion chamber operates at 1750 degrees Fahrenheit—above the melting points of such common metals as aluminum, magnesium, and zinc.

A number of unique features have been incorporated into the Ford engine design. Of significant interest to the military is the fact that the engine is virtually two engines in one. As a fuel-saving standby power plant, the unit is capable of delivering up to 45 hp from two accessory power take-offs with effectively only half of the engine running. By pushing a reset button on the control panel, the supercharging section of the engine is activated and the full 600 hp output of the engine is immediately available.

The turbocharged cycle consists of two stages of compression, using centrifugal compressors with air-to-air intercooling. From the high-pressure compressor, the air is manifolded to the recuperator, or heat exchanger matrix,



and then to the primary combustor where fuel is added to the air and combustion takes place. From the primary combustor, the hot gases pass through the high-pressure compressor turbine and into a secondary, or reheat combustor, where fuel is again added before passing the gas through the power turbine and the low-pressure turbine which drives the first, or turbocharged, stage of compression. From the low-pressure turbine, the gas is diffused and slowed down in velocity before entering the recuperator where it then exhausts into the atmosphere.

The engine consumes approximately 1/2 pounds of air per second, which in the process of compression through the two compressors is raised in pressure to approximately 214 psi. The temperature of the gas in each of the two combustors before passing through the turbines is 1750 degrees F. The temperature of the gases exhausting from the recuperator of the engine to atmosphere is approximately 660 degrees F.

The engine consists of five separate assemblies all of which can be easily disassembled from the main engine assembly for servicing or replacement. The low-pressure or supercharging section

of the engine comprises a single-stage centrifugal compressor which rotates at 36,600 rpm and is driven by a two-stage turbine. Discharge of the compressor is into a dual outlet plenum chamber on which are mounted the two intercooler matrices. The intercooler fan, which discharges into a plenum chamber mounted between the two intercooler units, is driven by the low-pressure-spool shaft through a spiral-bevel-gear drive train.

The second assembly is the high-pressure spool which receives air from the intercooler connecting duct. The spool comprises an overhung back-to-back centrifugal compressor radial-inflow turbine, the centrifugal compressor discharging from a single scroll outlet connection to the recuperator matrix. Rated speed of the compressor is 75,500 rpm. The assembly is bolted to the rear main casing casting which is the backbone of the engine on which the primary combustion chamber is mounted. The primary combustor receives air from the recuperator and discharges into the radial inflow turbine driving the compressor, which exhausts into a diffuser duct and into the reheat burner.

The third assembly of the engine con-

sists of the power turbine and reduction gear box. The power turbine rotates at 36,600 rpm, the speed being reduced by a planetary reduction gear to 6000 rpm at the output shaft. The power turbine assembly is a plug-in unit to the rear main casing casting, the power turbine scroll mating with the reheat combustor at assembly.

The fourth major assembly is the recuperator, which is mounted to the low-pressure-spool exhaust diffuser casing on the right-hand side of the engine. The unit consists of two matrices which can be individually disassembled with distribution headers connecting the high-pressure compressor and the primary combustor.

The fifth major assembly consists of the accessory gear box which is driven by a spiral bevel gear and shafting arrangement from the high-pressure compressor shaft. The gear box is mounted on the left side of the engine and has an integral oil sump, the main engine lube pumps, and the fuel control and starter. Provision is also made on this gear box for two accessory pads with a total rating of 45-horsepower output and a drive for an oil cooler fan or water pumps.

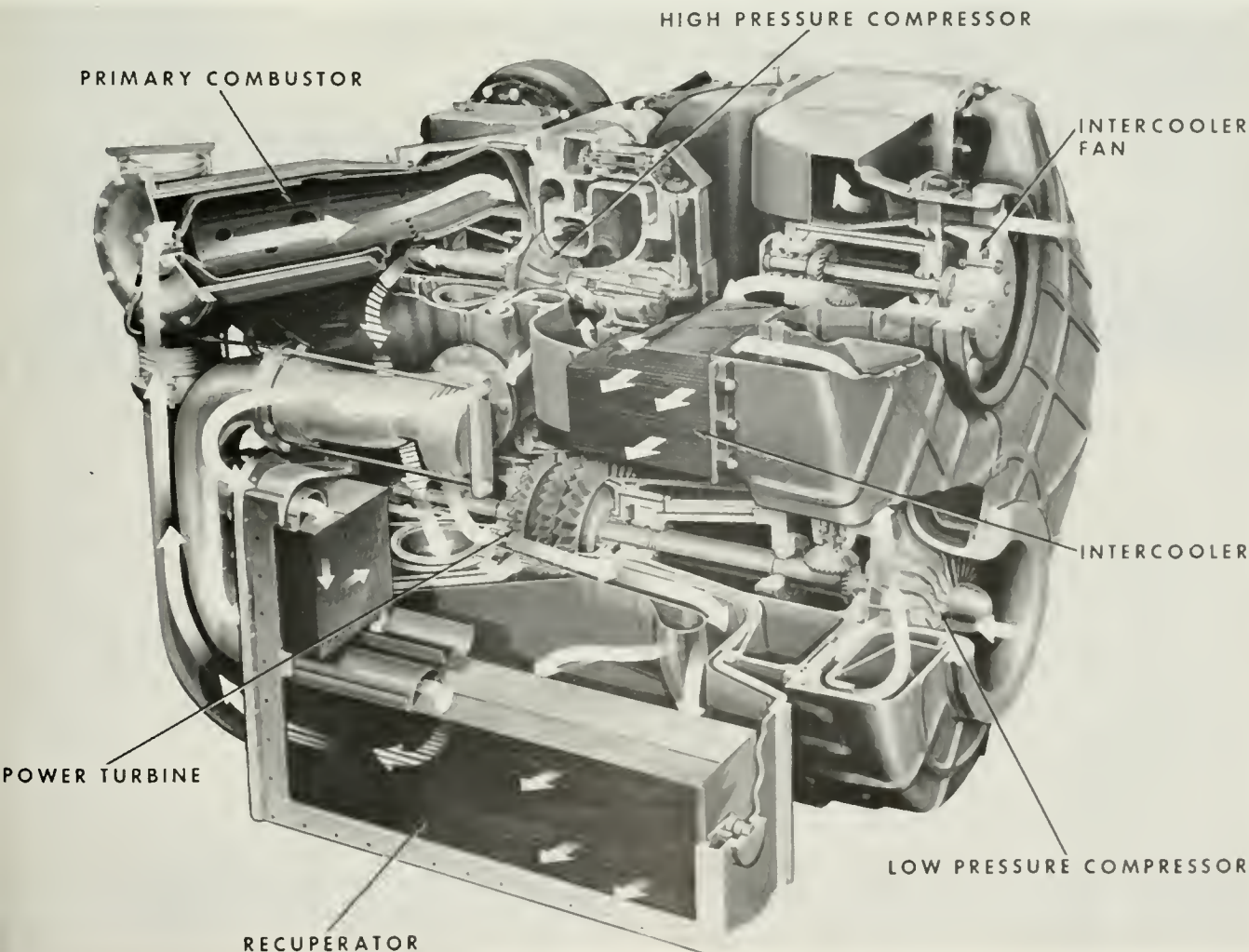

## *Assignment: put more pep per pound into Ford-built engines*

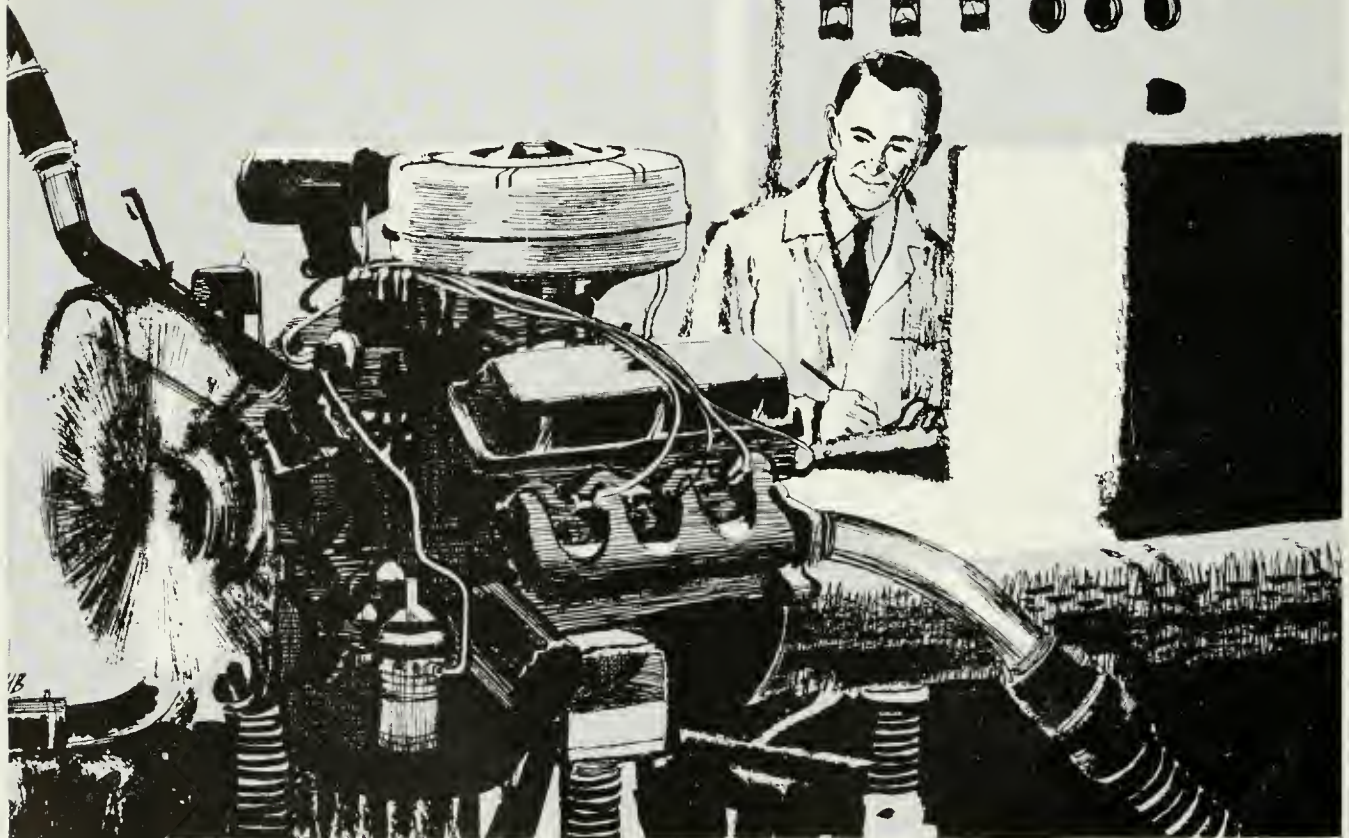

### **Result: New family of lightweight powerplants . . . including a new V-8 that weighs 110 pounds less than the comparable V-8 it replaces**

In our search to provide good performance with lighter powerplants, Ford Motor Company engineers and foundrymen have pioneered new techniques that now let us cast our engine blocks with such precision that much lighter engines are made possible.

New materials used to make cores and molds and new casting methods enable us to make engine parts with walls as thick as necessary—but no thicker. This eliminates weight of extra material which must be used to provide adequate strength with less precise casting methods.

Reducing engine weight through precision casting means more performance per pound—and since

lighter engines mean overall car weight can be reduced, better fuel economy results.

Another assignment completed—another Ford First—and one more example of how Ford Motor Company continues to provide engineering leadership for the American Road.



**MOTOR COMPANY**

The American Road, Dearborn, Michigan

**WHERE ENGINEERING LEADERSHIP  
BRINGS YOU BETTER-BUILT CARS**



# BEGINNING

by Kenneth J. Breeding

If the following essay seems difficult or obscure, it is meant to be, but it **does** have a thought pattern. A brief explanation is therefore supplied as an outline and guide to understanding. The ideas presented have as their basic roots relatively complex physical and philosophical concepts. Thus, any explanation would, by necessity, be overshadowed by thought. With this in mind, however, a hint as to the full meaning is given. Be sure to read the essay before reading the key.

## ESSAY

I've done my part and now I can rest. Time fleets too rapidly to finish. I'm sorry, and yet someday some brilliant mind may win. If only I knew that last little factor, all would be well. War—disgusting, yet I could have solved that problem if only time and knowledge hadn't run out. To die is not so bad, but to not finish is quite depressing. Unfortunately one can't obtain all knowledge—how disappointing. Tomorrow I'll rise and be done with it and yet never finish.

What's this? I see colors: black and white, orange and blue, trees, sky—oh, well, only passing of time until this is over. I see it. I see it! The solution. No, not I, we—we see it. If only I or we could tell before it happens. I see clearly and now we know all—we see all and nothing is a mystery any more. I note a long slender green thing feeding itself—from light. And yet I know it, for *we* know everything. What is this? I don't know these things and yet I do. Knowledge is all and symmetry is everything and all is necessary.

And yet now the quanta are becoming less frequent and lower in energy. Sol dies—slowly, oh so very slowly. Below, the blue sphere turns brown, and brown shifts low. Entropy cannot be reversed.

Ah, yes, and now it is gone and void remains with mind and lines of symmetry. But around there is nothing, for I am not me but we, and all is necessary to change. To change what? Ah, it's clear: when Sol is worshipped, thermodynamics is little understood.

Change to home takes work. This problem must be solved. And yet we have all to do—to work. Group it, shape it, twist it. Twist it? But why, and yet it is clear why. Home is solid and their problems will be solved. To work *on* is necessary; to think *on* is not, for thought has knowledge and all knowledge is us—to work on. The twist yields the hurdles to overcome. Thus a test to try again. The problem is simple, for we now understand but must go on. For to solve the twist, all will be successful, and home is here and yet there, and murder is through—eventually. We'll repeat and do good rather than evil this time.

Now the levels are here, straight and symmetrical. Symmetry means all for success and yet the twist of lines defeats it. Problems to solve—successfully this time. Now to adjust them a little more to obtain the proper word patterns of us, us and symmetry—a little more and just a bit. Ah, now we have it, let us say, "Let there be light." ◆◆◆

## KEY

The sketch opens with a man lying on his deathbed, thinking. His thoughts concern an engineering and military and social problem on which he had been working, that of war and its elimination. On this, he had failed as a result of lacking some small piece of information. The last sentence of the first paragraph shows that he knows he will die soon and yet live on.

The second paragraph begins with his death: note the change in colors and in objects. He doesn't realize this transition, however, for he thinks, "—oh, well, only passing of time until this is over." Then he finds the solution to his problem which, unfortunately, he cannot communicate to earth. Now follows a series of visions in which he cannot realize that his all-knowing mind still exists. Yet it does, for he "knows" both the blade of grass, slender and green, and the process of photosynthesis. He also recognizes that he is not any longer just an entity but all things physically and theologically (note the reference to I and We). The last sentence then draws the analogy between knowledge and symmetry.

The third paragraph occurs many trillions of years later. Our thinker observes that the stars are dying. This conclusion is hinted at through the first and second sentences. He realizes that the Earth, "the blue sphere," is dying also. Finally all is gone in the decaying, energy-disorganizing "flow" of entropy.

After the death of the sun and the earth and all of the galaxies, he and they, separately and combined, united, try to find out how to start over again. In the last sentence of the fourth paragraph he discovers what is needed to do this. (This sentence is well worth thinking about.)

The remaining two paragraphs simply tell how he, or others, can go about this creation. There is much more in those two paragraphs than is suggested here. The curious reader may resolve further meanings himself. ◆◆◆



TECHNOCUTIE . . . . .

## *Miss Flo Gault*

### **An Engineer's 'IDEAL' gal**

Truth should always supersede modesty, and in the case of Miss Florence (Flo) Gault it is a pleasure. Flo is perhaps the most "ideal" gal TECH has met during its 75 years of publication . . . This, by definition, makes her an engineer's daughter!

Flo was chosen Miss 1961-62 Champaign AmVet, Miss Illinois AmVet, and a finalist in the Miss America AmVet Contest held in New York last summer. Her radiating personality can be described best by quoting the AmVet's personality scoring cards. . . . Out of 50 possible points Flo scored 49!

She hails from Chicago, and during her 21 busy years she has been a professional fashion model for Morris B. Sacks, Carson Perry Scott, Marshall Fields, and the Chicago Tribune. Upon graduation in LAS next February she expects to become a high school teacher.

On the U. of I. Campus Flo has been a finalist for Illio Beauty and semi-finalist for Dolphin Queen as well as Sigma Kappa's Ideal Girl for Greek Ball Queen. She is a former activity editor of the Daily Illini, and her many hobbies include sewing, piano, swimming and water skiing.

TECH's Crystal Ball has indicated that Flo is particularly partial to General Engineering instructors (or is it only one?) with a B.S. in Mechanical Engineering working on an Economics degree. . . . We strongly suggest all interested persons in these areas investigate immediately—with due caution of course!!



## What does lin do for a living?

### A lot of things. Some of them might surprise you. Read this.

Olin conceives new products at a rate of no less than one a week. Some appear under our own name. Others bring fame to our customers.

Did you know that Olin pioneered liquid chlorine and synthetic ammonia in the U.S.? Is a leader in agricultural chemicals and synthetic detergent builders? Makes the hydrazine derivatives used as missile fuels? Some of the work of our **CHEMICALS DIVISION**

Common clay is now anything but "common." In the lab, we recently developed an economical process to convert clay into — of all things — alumina. Stronger metals, new alloys, and metal sources that would have made alchemists scoff in disbelief, are now being pioneered by our **METALS DIVISION**

Our organic intermediates — those polysyllabic tongue twisters only chemists can pronounce easily — are used in

the manufacture of many new "wonder" plastics. We recently developed smokeless Ball Powder® with many immediate uses, and many more astonishing potentials. New and better explosives, detonators and blasting caps are challenges in Olin's **ORGANICS DIVISION**

Our research teams are probing for new films to keep foods fresh longer. We work with packaging materials from cellophane to kraft paper, corrugated boxes to lumber. The seemingly incongruous quests for crisper potato chips, lighter weight printing papers and more effective cigarette filters are all part of Olin's **PACKAGING DIVISION**

In the very research center where

penicillin was first crystallized, scientists now probe for a B<sub>12</sub> antagonist to arrest cancer. On any given day, 150 of our drugs or new dosages may be undergoing clinical tests throughout the world. From Olin's **SQUIBB DIVISION**

Olin even works on your leisure, with sporting arms and ammunition. We discovered a new way to make a shotgun barrel by winding 500 miles of Fiberglas® around a thin steel liner. It is superior to all-steel barrels on many counts. Ammunition research led to development of powder-actuated tools for faster, stronger fastenings in construction. At our **WINCHESTER-WESTERN DIVISION**

Olin products are sold in virtually every free country in the world. Sales, service and manufacturing for overseas markets are the responsibilities of our **INTERNATIONAL DIVISION**

Olin Mathieson Chemical Corporation, 460 Park Avenue, New York 22, N. Y.



# 1964 WORLD'S FAIR

Seen by Artist John C. Wenrich in its permanent setting at Flushing Meadows, this is Unisphere, symbol of the 1964-1965 New York World's Fair to be fabricated, built and presented by United States Steel Corporation. Towering 12 stories above its pedestal, the Unisphere will feature land masses fabricated of rigidized stainless steel with a unique pattern, designed to heighten the effect of lights playing on it. The photo to the right shows the Unisphere under construction.



## Atomic-Electric Generating Station

The dreams of nuclear power lighting a city are coming true. An atomic-electric generating station in Buchanan, New York, 35 miles from the center of New York City can presently furnish 275,000 of the six million kilowatts needed to serve the city. The steam that drives the turbine gets approximately two-thirds of its heat from the atomic reactor and one-third from oil fired superheaters. The core of the reactor uses thorium as fuel and will last approximately two years without refueling.





## New Magnetic Shoes

This man is walking upside-down against the full pull of gravity to demonstrate a new permanent-magnet system developed at the Westinghouse Research Laboratories. Permanent magnets attached to the soles of his shoes clamp his feet securely to a steel beam. But unlike other permanent magnets they can, in effect, be turned on and off. The man can free his foot, take a step, then clamp it tight again. The new magnets need no constant source of electrical power as do conventional electromagnets, yet are just as easily controlled.

## Stainless Steel Satellite

The latest in satellites is the stainless steel model shown here undergoing vibration tests that simulate the strain of launching. The shell is thinner than a match cover, non magnetic, strong and nearly leakproof. For these reasons stainless steel is taking its place in the space age.

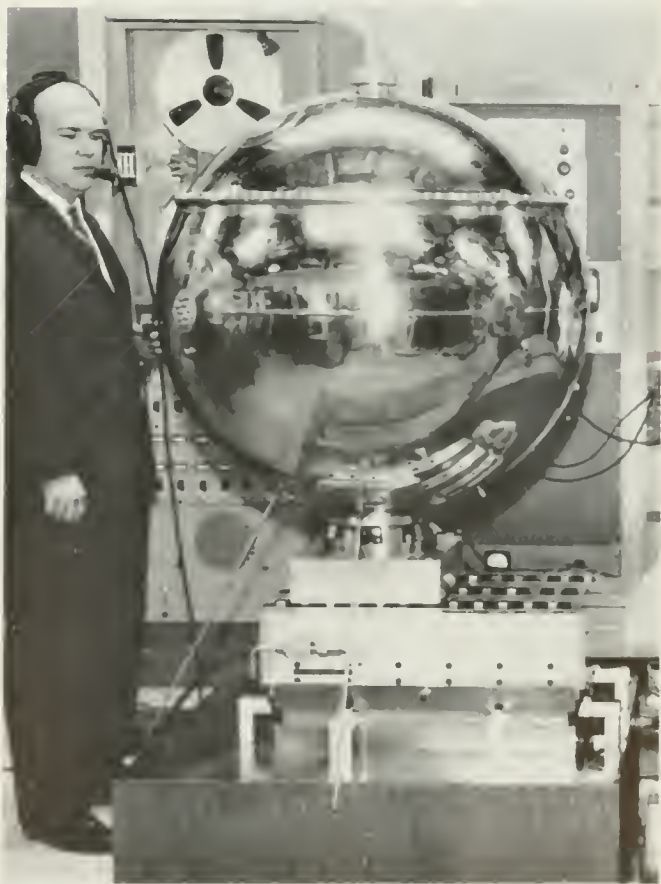

# NEWS & VIEWS

at the  
U. of I.

## High Turbo-Charging of Diesel Engines

Recent research at the University of Illinois shows that a new level of diesel engine performance may be available in the near future.

Four-stroke gasoline engines that develop one or more brake horsepower per cubic inch of piston displacement have been produced for a number of years. These include engines for racing cars, larger aircraft engines of the reciprocating type, and, more recently, passenger and sports car engines. According to an investigation by Professor W. L. Hull of the University of Illinois Department of Mechanical and Industrial Engineering, it should be feasible to develop at least one horsepower per cubic inch of piston displacement in a production four-stroke diesel engine.

A single-cylinder, open combustion chamber diesel engine was equipped so that boosting the intake air pressure by means of an exhaust-driven turbosupercharger could be simulated. Compressed air was used at the intake, and the exhaust back pressure was controlled in proportion to that required to operate the turbine. The intake air temperature was regulated by using electric heaters. The intake air was boosted in excess of three atmospheres pressure and the effect of using after cooling to 200° F intake air temperature was simulated. These conditions were sufficient to produce one horsepower per cubic inch of piston displacement at 2,600 revolutions per minute speed. In addition to giving very high power output, high supercharging also reduced the fuel consumption per horsepower output by 24 per cent. This was because of the reduced percentage of friction and heat loss from the combustion chamber.

By using aftercooling of the intake air, excessive temperature due to compression can be avoided. This cooling can be accomplished by using either an air-to-air or an air-to-water heat exchanger, the latter being arranged to use cooling water coming from the engine radiator. By reducing this temperature, the specific weight of the intake air is increased further, so that more fuel can

be burned, thereby increasing the horsepower still further. This also saves on the amount of work expended in supercharging, accounting partly for an improvement in fuel consumption.

High turbosupercharging should allow engine builders to produce more compact engines of lighter weight and lower cost per horsepower. The cost of operation of such engines should be extremely low because of the improved fuel consumption. In this test, brake mean effective pressures as high as 320 pounds per square inch were measured at 1,800 revolutions per minute, which gave maximum gas pressures in the engine cylinder of 2,800 pounds per square inch. This required making some of the engine parts considerably stronger to withstand the high stresses. The thermal efficiency of the engine ran as high as 39 per cent. A multicylinder engine of the same bore and stroke should be even better than this because multicylinder engines have a lower percentage of friction and heat loss than a single-cylinder engine.

Professor Hull presented a technical paper on this research, "High Output Diesel Engines," at the annual meeting of the Society of Automotive Engineers in Detroit on January 16. Copies of this paper are available from the SAE, 485 Lexington Avenue, New York City. (*Reprinted from Engineering Outlook*)

## People and Places

Prof. R. C. Fuson, a distinguished chemist who has been at the University of Illinois since 1932, has been honored by a \$10,000 gift from nearly 400 former students and associates to be used as he may suggest for the benefit of chemists and chemistry at the U. of I.

Dr. N. M. Newmark, Head of the University of Illinois Department of Civil Engineering, received the Theodore van Karman Medal of the American Society of Civil Engineers in October "in recognition of distinguished achievement in engineering mechanics and especially in structural dynamics."

Dr. R. B. Peck, Professor of Civil Engineering at the University of Illinois, was installed in October as a member of the Board of Direction of the American Society of Civil Engineers for a term of three years. He is now director for most of Illinois and part of eastern Iowa.

Charles H. Henry, graduate student in Physics at the University of Illinois, was awarded the Eastman Kodak Scientific Award of \$1,000 in October. This prize is awarded "on the basis of outstanding contributions and progress either in graduate studies and research or in teaching."

## Even When Its Not Pure, It Floats

Because the world's mineral resources are being used up so rapidly, today it is necessary to look for and try to obtain lower grade ores than would have been considered acceptable in the past. If mineral prices are to be kept reasonable, new methods of mineral beneficiation must be found or greater efficiency must be introduced into old methods. One of the widely used mineral processing methods in use today, flotation, is the subject of extensive research in the University of Illinois Mining, Metallurgy, and Petroleum Engineering Department by a group under the direction of Professor Norman Street.

Flotation is a process by which minerals are floated to the top of a liquid surface where they can be collected. The addition of the proper kind and amount of chemicals to the water for the mineral being separated will make air bubbles stick to mineral particles and float to the surface, leaving the useless impurities behind. Today many millions of tons of ores are processed in this manner.

Although it is well known that the right chemical in the right quantity will make a given mineral stick to the bubble and rise to the surface, much remains to be learned about the electrical potential differences between the liquid surface and the mineral surface. This is one of the facets of flotation being studied by Professor Street's group. When a captive air bubble is brought up to a mineral surface under a microscope, it is possible to see that a thin film of liquid persists for some time between the bubble and the mineral. To increase the efficiency of the flotation process, the time interval before this film ruptures must be made as short as possible. These rupture times are a function of the surface potential developed at the mineral-solution interface, and Professor Street's group is studying methods of changing surface potentials in order to speed film ruptures.

The group is also studying the "contact angle" between the liquid and the mineral, i.e., the angle a drop of the solution will adopt to the mineral surface in air, which affects the ability of a bubble to stick to the surface of the mineral. There appears to be a relationship between surface potential and rupture time. Although quite a lot of fundamental work has already been done, much remains to be learned about such interfacial phenomena. These studies of hydromechanics, electroviscosity, and electrokinetics take on more and more importance as our iron ore, petroleum reserves, and other mineral resources become harder to find, harder to obtain, and harder to refine. (*Reprinted from Engineering Outlook*)



# UNMANIFEST PRIDE

The great liability of the engineer compared to me of other professions is that his works are out in the open where all can see them. His acts, step by step, are in hard substance. He cannot bury his mistakes in the grave like the doctors. He cannot argue them into thin air or blame the judge like the lawyers. He cannot, like the architects, cover his failures with trees and vines. He cannot, like politicians, screen his shortcomings by blaming his opponents and hope that the people will forget. The engineer simply cannot deny that he did it. If his works do not work, he is damned. That is the phantasmagoria that haunts his nights and dogs his days. He comes from the job at the end of the day resolved to calculate it again. He wakes in the night in a cold sweat and puts something on paper that looks silly in the morning. All day he shivers at the thought of the bugs which will inevitably appear to jolt its smooth consummation.

On the other hand, unlike the doctor his is not a life among the weak. Unlike the soldier, destruction is not his purpose. Unlike the lawyer, quarrels are not his daily bread. To the engineer falls the job of clothing the bare bones of science with life, comfort, and hope. No doubt as year go by people forget which engineer did it, even if they ever knew. Or some politician puts his name on it. Or they credit it to some promoter who used other people's money with which to finance it. But the engineer himself looks back at the unending stream of goodness which flows from his successes with satisfactions that few professions may know. And the verdict of his fellow professionals is all the accolade he wants.

—From Herbert Hoover, *The Memoirs of Herbert Hoover: Years of Adventure*. Copyright 1951 by Herbert Hoover, The Macmillan Company.

# BIG DECISION

For Engineers  
-To-Be...

## SHALL IT BE

#9000 Castell Wood  
Drawing Pencil or  
#9800SG Locktite Tel-  
A-Grade Holder and  
#9030 Castell Re-  
fill Drawing Leads ?

Perhaps you will choose Castell wood pencil, because you like the feel of wood, because you like to shave the point to the exact length and shape you desire.

Or you may vote for Locktite Tel-A-Grade, the lightweight balanced holder with its long tapered, no-slip serrated grip that soothes tired fingers. And its ideal team mate, Castell Refill leads, of the same grading, undeviating uniformity and bold image density of Castell wood pencil.

Whatever your choice, you will be using Castell tight-textured microlet-milled lead that gives you graphite saturation that soaks into every pore of your drawing surface.

Your College Store carries all three famous A.W. Faber-Castell drawing products, backed by over two centuries of pencil-making experience. Start your career by using the finest working tools money can buy.

## A.W. FABER- CASTELL

Pencil Company, Inc.  
41-47 Dickerson Street  
Newark 3, N. J.



# BRAINBUSTERS

1.

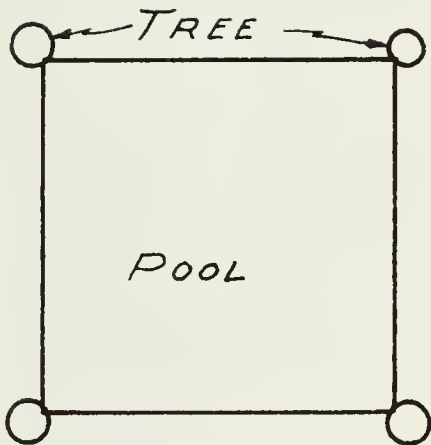

A man has a square swimming pool with trees growing at each corner. He wants to double the area of the pool, but still keep it square. How can he do this without moving the trees? Of course, he doesn't want the trees in the pool.

3.

At the Green's family party, two tables sat down to play bridge. Those participating were Messrs. Green, Pink, Black, and White, and their respective wives.

White's partner was his daughter. Pink was playing against his mother. Black's partner was his sister. Mrs. Green was playing against her mother. Pink and his partner had the same mother. Green's partner was his mother-in-law.

No player's uncle or step-uncle was participating.

Who partnered whom, and how were the tables made up?

4.

I bowled a game with 8 strikes. No ball went into the gutter and I didn't four, but my score was less than 100. What happened in each frame?

2.

The ends of a 30 foot rope are attached to the facing sides of two buildings. The sag in the rope is 15 feet. How far apart are the buildings?

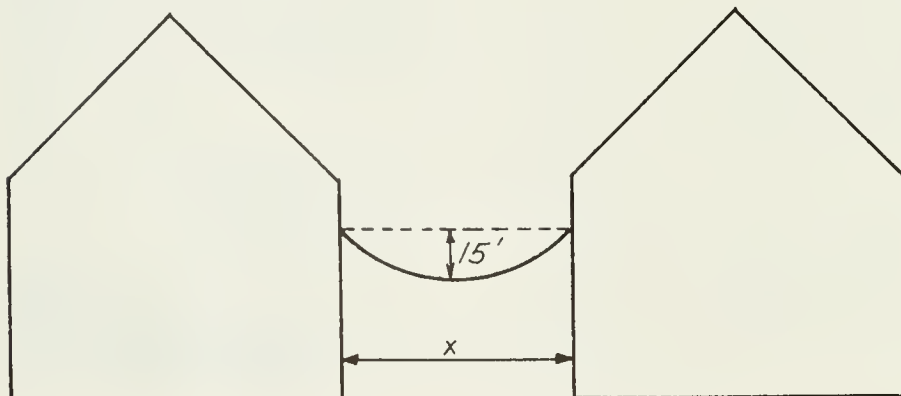

5.

What digits do the letters represent in this cryptic addition problem?

$$\begin{array}{r} \text{T W O} \\ \text{T H R E E} \\ \hline \text{S E V E N} \end{array}$$

T W E L V E

It is obvious that the values for "O" and "N" may be interchanged.

6.

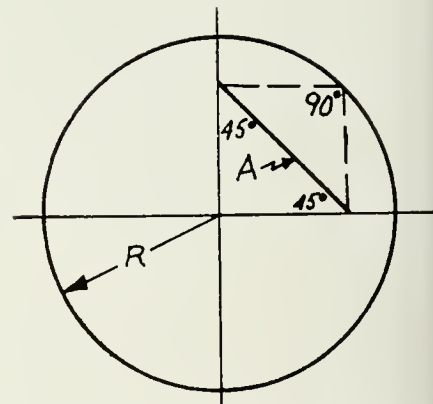

How long is line A?

7.

An important clue in a murder mystery was the dead man's "perfect" watch, which had stopped at the instant of the murder. However, the investigation officer had carelessly turned the hands in attempting to start the watch, and could not remember what time was indicated. He did recall that the hour and minute hand had been together and that the second hand had just passed the 49th second. At what time was the murder committed?

(See answers on page 24)



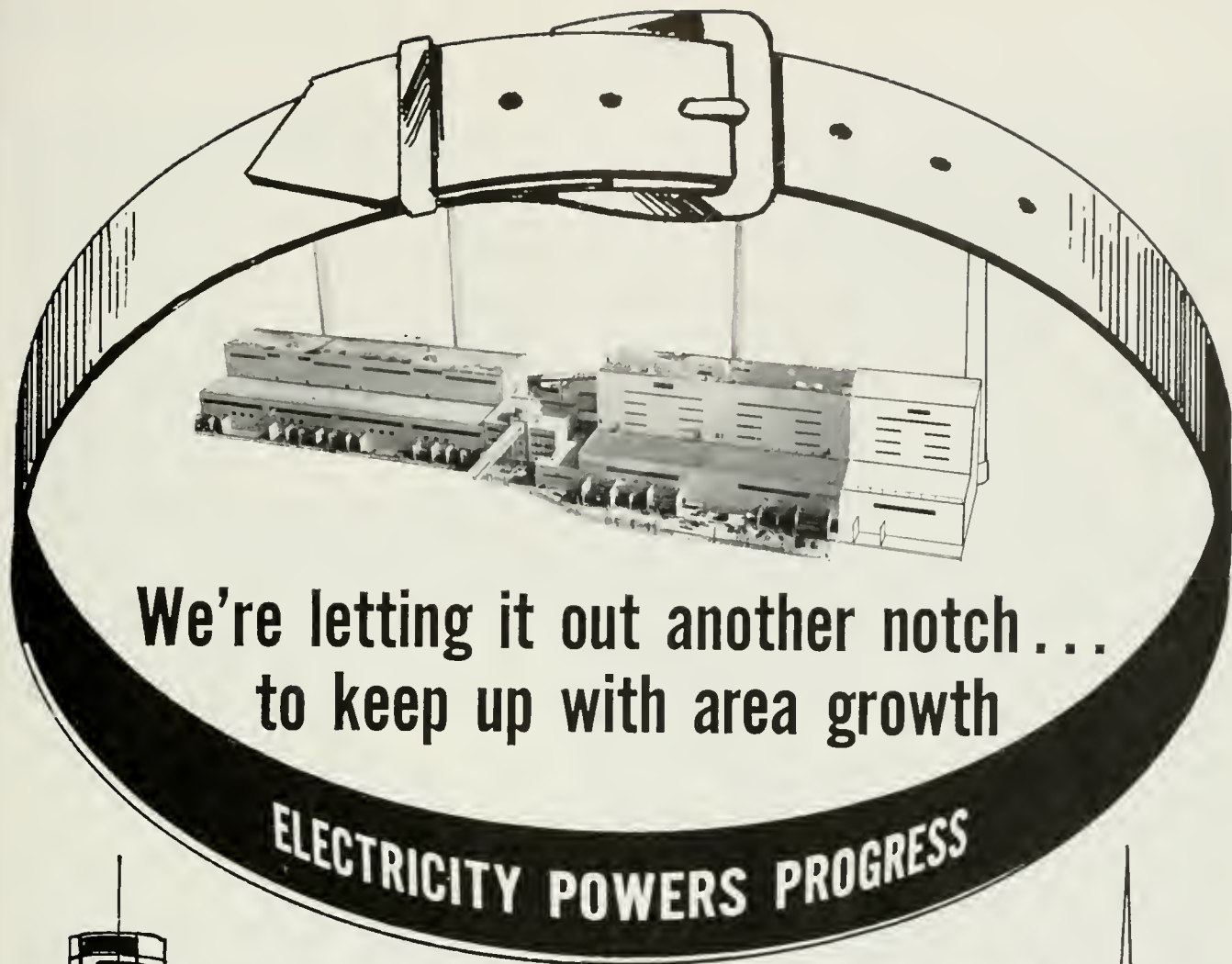

**We're letting it out another notch...  
to keep up with area growth**

**ELECTRICITY POWERS PROGRESS**



When economic activity grows at the rate it has in our service area — it needs the support of plenty of electric power. That's why we plan to add a 310 megawatt generating unit to our Oak Creek power plants by mid-1965. Addition of this seventh unit will increase the total capacity of the Oak Creek plants to 1,360 megawatts.

Building ever larger and more efficient generating units is one way that our company helps electricity power progress. Research in atomic power is another. And our engineers — assisted by computers — are "building" the power distribution systems of tomorrow.

Write us about engineering positions in all fields — plenty of opportunities to pioneer in a key industry!

## **WISCONSIN ELECTRIC POWER COMPANY SYSTEM**

Wisconsin Electric Power Co.  
MILWAUKEE, WIS.

Wisconsin Michigan Power Co.  
APPLETON, WIS.

Wisconsin Natural Gas Co.  
RACINE, WIS.

# TECHNOQUIPS

With due respect to old Charlie Darwin, although man has learned through evolution to walk in an upright posture, his eyes still swing from limb to limb.

\* \* \*

The two Madison Avenue types met on the suburban train platform.

"Hi, Charley," greeted the one, "how is your wife?"

"Compared to what?" responded the other dryly.

\* \* \*

Then there's the one about the Texas oilman who went to see his dentist and, when asked which tooth was bothering him, replied, "Oh just drill anywhere, doc, I feel lucky today!"

\* \* \*

A school inspector, to get an idea of the standard of teaching, entered a classroom while the lesson was in progress and decided to ask the children some questions.

Calling on one small boy he asked, "Who broke down the walls of Jericho?" The boy answered, "Not me, sir." The inspector turned to the teacher and asked, "Is this the usual standard in this class?" The teacher replied, "The boy is usually quite honest, so I believe him."

Leaving the room in disgust the inspector sought out the headmaster and explained what had transpired.

The headmaster said, "I've known both the teacher and boy concerned for several years and I'm sure that neither of them would do a thing like that."

By this time the inspector was furious and reported the incident to the director of education.

The director said, "I feel, you know, we are making a mountain out of a molehill in this case. I suggest we pay the bill and write the sum off."

\* \* \*

Angry wife: "One of the ducks you were out shooting yesterday called and left her number."

Freshman Engineer: "It says here that if we study hard, don't drink, smoke, or run around with girls we'll live longer. Is that true?"

Professor: "We won't know for sure until somebody tries it."

\* \* \*

The Kennedy family slogan: "Anything you can do my kin do better."

\* \* \*

There are three ways of courting ruin—women, gambling and calling in technicians.

\* \* \*

Motto hanging on office wall of a research department: "This problem, when solved, will be simple."

\* \* \*

The regular noontime poker session of a group of Phoenix, Ariz., electronic engineers is neatly labeled with a sign reading: "Probability Seminar."

\* \* \*

A man is incomplete until he's married—then he's really finished.

\* \* \*

"All-Purpose Political Speech for Any Audience." Its opening paragraph:

"These are perilous times. We stand at the crossroads of decision, the frontier of destiny. Years ago this was not as true as it proved to be later on. Today there is an increase of 23 per cent in the national index alone. Mental illness accounts for an appalling three per cent. The rest goes for taxes."

\* \* \*

The main advantage of being a nudist is that after you've been in for a swim you don't have to sit around in a wet bathing suit.

\* \* \*

The human brain is wonderful. It starts working the moment you wake up in the morning and doesn't stop until you are called on to recite in class.

\* \* \*

Math Prof: Now, if I subtract 25 from 37, what's the difference?

Fresh: Yeah! That's what I say. Who cares?

The Soviet commissar was examining a young Czech boy to determine whether he had been properly indoctrinated. When asked who his father was the boy replied "Joseph Stalin."

Beaming, the examiner then asked who his mother was. "The Great Soviet Union," came the prompt reply.

"Splendid," grinned the commissar, "you'll make a fine Red Army soldier. Now tell me," he continued, "what do you want to be when you grow up?"

"An orphan!" snapped the boy.

\* \* \*

Social Worker: "Sir, would you be interested in contributing something to the old ladies home?"

"Yes, I'll send my mother-in-law over tomorrow."

\* \* \*

The bandage-covered patient who lay in the hospital bed spoke dazedly to his visiting pal:

"What happened?"

"You absorbed too many last night, and then made a bet that you could fly out the window and around the block."

"Why," screamed the beat-up C.E., "didn't you stop me?"

"Stop you, hell, I had \$25 on you."

\* \* \*

The young wife approached a post office window and said, "I wish to complain about the service."

"What's the trouble, madam?" the clerk wanted to know.

"My husband is in Atlanta on business and the letter he sent me is post-marked Miami Beach."

\* \* \*

Once upon a time, as the story goes, the fence between Heaven and Hell broke down. Satan appeared at his side of the broken section and called out to St. Peter: "Hey, St. Peter, since all the engineers are over on your side, how about sending a few to fix the fences?"

"Sorry," replied St. Peter, "my men are too busy to fix fences."

"Well then," said Satan, "I'll have to sue you if you don't."

St. Peter: "Guess you win; you've all the lawyers on your side."

\* \* \*

"You can't beat the system," moaned an U.I. student after looking at his semester grades. "I took a course in basket weaving for a snap elective and then two navalos enrolled and raised the curve so that I flunked."

## BRAINBUSTER ANSWERS

Numbers 1, 2, and 6 are rather simple. If you can't figure them out ask your roommate.

Number 3. We don't even know the answer yet. Find out next month on the Technoquips page.

5.

106	or	104
19722		19722
82524		82526
-----		-----
102352		102352

Number 4. A score of 99 is possible with strikes in all frames (including 11th and 12th) except the 3rd, 5th, 7th, and 9th. The no-strike frames are characterized by the horror of one down plus a miss. Slight variations are possible; for example the 2nd instead of 3rd frame might be substandard.  
7. 4:21:49 1/11



## Kodak beyond the snapshot...



Physical chemist. Currently working for the electronics industry. Salary by Kodak. Having a wonderful time.

Photography has penetrated everything, often unrecognized behind its disguises. With photography as a means of fabrication, the electronics business builds complex logic circuits smaller than the period at the end of this sentence. Technique depends on liquids hardened by light. Electronics engineers, knowing little about photopolymerization, turn to Kodak engineers. Kodak engineers turn to Kodak physical chemists for the photopolymers. *Ergo*, we pay physical chemists to work for the electronics industry. Typical instance of the delightfully unpredictable matchmaking that goes on in a thoroughly diversified outfit.

Some people, who will always prefer the scientist's way of life to any other, nevertheless derive a large bang from working often with engineers. Some people who class themselves engineers feel it can be a dull life without personal contacts with the sources of new knowledge. Kodak is a good place for these people to meet.

*Maybe your interests and our interests match up somewhere. Write.*

**EASTMAN KODAK COMPANY** • Business & Technical Personnel Department  
ROCHESTER 4, N.Y. • We are an equal-opportunity employer.



Manager—Engineering Recruiting

## How to Make the Most of Your First Five Years

MR. HILL has managerial responsibility for General Electric's college recruiting activities for engineers, scientists, PhD's and technicians for the engineering function of the Company. Long active in technical personnel development within General Electric, he also serves as vice president of the Engineers' Council for Professional Development, board member of the Engineering Manpower Commission, director of the Engineering Societies Personnel Service and as an officer or member of a variety of technical societies.

**Q. Mr. Hill, I've heard that my first five years in industry may be the most critical of my career. Do you agree?**

A. Definitely. It is during this stage that you'll be sharpening your career objectives, broadening your knowledge and experience, finding your place in professional practice and developing work and study habits that you may follow throughout your career. It's a period fraught with challenge and opportunity—and possible pitfalls.

Recognizing the importance of this period, the Engineers' Council for Professional Development has published an excellent kit of material for young engineers. It is titled "Your First 5 Years." I would strongly recommend you obtain a copy.\*

**Q. What can I do to make best use of these important years?**

A. First of all, be sure that the company you join provides ample opportunity for professional development during this critical phase of your career.

Then, develop a planned, organized personal development program—tailored to your own strengths, weaknesses and aspirations—to make the most of these opportunities. This, of course, calls for a critical self appraisal, and periodic reappraisals. You will find an extremely useful guide for this purpose in the "First 5 Years" kit I just mentioned.

**Q. How does General Electric encourage self development during this period?**

A. In many ways. Because we recognize professional self-development as a never-ending process, we encourage technical employees to continue their education not only during their early years but throughout their careers.

We do this through a variety of programs and incentives. General Electric's Tuition Refund Program, for example, provides up to 100% reimbursement for tuition and fees incurred for graduate study. Another enables the selected graduate with proper qualifications to obtain a master's degree, tuition free, while earning up to 75% of his full-time salary. These programs are sup-

plemented by a wide range of technical and nontechnical in-plant courses conducted at the graduate level by recognized Company experts.

Frequent personal appraisals and encouragement for participation in professional societies are still other ways in which G.E. assists professional employees to develop their full potential.

**Q. What about training programs? Just how valuable are they to the young engineer?**

A. Quite valuable, generally. But there are exceptions. Many seniors and graduate students, for example, already have clearly defined career goals and professional interests and demonstrated abilities in a specific field. In such cases, direct placement in a specific position may be the better alternative.

Training programs, on the other hand, provide the opportunity to gain valuable on-the-job experience in several fields while broadening your base of knowledge through related course study. This kind of training enables you to bring your career objectives into sharp focus and provides a solid foundation for your development, whether your interests tend toward specialization or management. This is particularly true in a highly diversified company like General Electric where young technical graduates are exposed to many facets of engineering and to a variety of product areas.

**Q. What types of training programs does your company offer, Mr. Hill?**

A. General Electric conducts a number of them. Those attracting the majority of technical graduates are the Engineering and Science, Technical Marketing and Manufacturing Training Programs. Each includes on-the-job experience on full-time rotating assignments supplemented by a formal study curriculum.

**Q. You mentioned professional societies. Do you feel there is any advantage in joining early in your career?**

A. I do indeed. In fact, I would recommend you join a student chapter on your campus now if you haven't already done so.

Professional societies offer the young engineer many opportunities to expand his fund of knowledge through association with leaders in his profession, to gain recognition in his field, and to make a real contribution to his profession. Because General Electric benefits directly, the Company often helps defray expenses incurred by professional employees engaged in the activities of these organizations.

**Q. Is there anything I can do now to better prepare myself for the transition from college campus to industry?**

A. There are many things, naturally, most of which you are already doing in the course of your education.

But there is one important area you may be overlooking. I would suggest you recognize now that your job—whatever it is—is going to be made easier by the ability to communicate . . . effectively. Learn to sell yourself and your ideas. Our own experience at General Electric—and industry-wide surveys as well—indicates that the lack of this ability can be one of the major shortcomings of young technical graduates.

\*The kit "Your First 5 Years," published by the Engineers' Council for Professional Development, normally sells for \$2.00. While our limited supply lasts, however, you may obtain a copy by simply writing General Electric Company, Section 699-04, Schenectady, New York.

(An equal opportunity employer.)

Progress Is Our Most Important Product

GENERAL  ELECTRIC



# TECHNOGRAPH

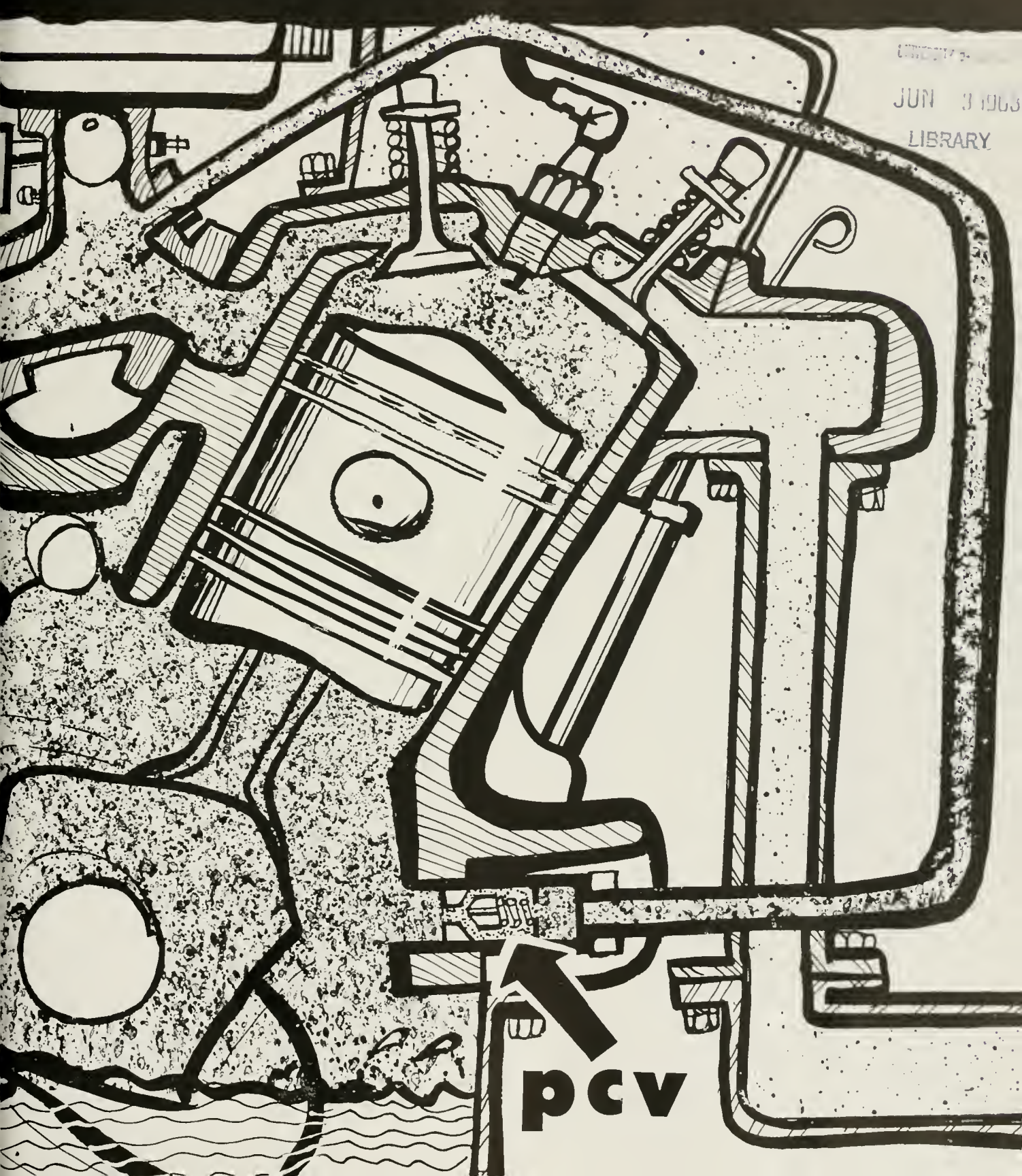

LIBRARY  
JUN 3 1963

**pcv**

New Westinghouse Ideas in Electronic Medicine

### Volts may do you more good than Aspirin . . .

An electronic device has successfully steadied hearts that were fluttering at the verge of failure. Slim electronic tubes, mounted as a test in the ceilings of 15 operating rooms, cut the rate of post-operative infections to a *fortieth* of what it was before. A new fluoroscope system makes the patient more comfortable and permits the doctor to

make his examination from a distant location where he observes by television. Indeed, several doctors may observe at one time. Future possibilities include a "listener" to tell just how the heart of an unborn infant is doing and a "looker" to locate bone fractures without radiation. Scientists over the world are working on new ways to help doctors treat the complex machine we call the human body. "Electronic Medicine" is a major research area at Westinghouse. *You can be sure . . . if it's Westinghouse*

Westinghouse



For information on a career at Westinghouse, an equal opportunity employer, write L. H. Noggle, Westinghouse Educational Dept., Pittsburgh 21, Pa.

*Paul*



**Editor-in-Chief**

Wayne W. Crouch

**Business Manager**

Gary Daymon

**Production Manager  
and Assistant Editor**

Stuart Umpleby

**Circulation Manager**

Larry Campbell

**Editorial Staff**

Art Becker

Thelma McKenzie

Jim Walters

**Business Staff**

Phillip Johnson

Wayne Worthington

**Production Staff**

Mike Glowacz

**Circulation Staff**

Bob Bittner

Paul Gihring

George Muellner

**Photography**

Joe Figueira

**Secretary**

Kathie Liermann

**Advisors**

R. W. Bohl

P. Bryant

W. M. Hudson

E. C. McClintock

# THE ILLINOIS TECHNOGRAPH

Volume 78; Number 8

May, 1963

## Table of Contents

ARTICLES

Modern Railroads .....	Thomas Osika	6
Lasers as Machine Tools .....	Art Becker	10
An Engineer Speaks .....		12
Air Pollution .....	Leonard Shuck	16

FEATURES

Tech Says .....	Gary Daymon	2
The Dean's Page .....	Dean H. L. Wakeland	4
Technocutie .....		21
Technoquips .....		24

MEMBERS OF ENGINEERING  
COLLEGE MAGAZINES ASSOCIATED

Chairman: J. Gale Chumley  
Louisiana Polytechnic Institute  
Ruston, Louisiana

Arkansas Engineer, Cincinnati Coopera-  
tive Engineer, City College Vector, Colorado  
Engineer, Cornell Engineer, Denver Engi-  
neer, Drexel Technical Journal, Georgia  
Tech Engineer, Illinois Technograph, Iowa  
Engineer, Iowa Transit, Kansas Engineer,  
Kansas State Engineer, Kentucky Engineer,  
Louisiana State University Engineer, Louisi-  
ana Tech Engineer, Manhattan Engineer,  
Marquette Engineer, Michigan Technic, Min-  
nesota Technolog, Missouri Shamrock, Ne-  
braska Blueprint, New York University  
Quadrangle, North Dakota Engineer, North-  
western Engineer, Notre Dame Technical  
Review, Ohio State Engineer, Oklahoma  
State Engineer, Pittsburgh Skyscraper, Pur-  
due Engineer, RPI Engineer, Rochester In-  
dicator, SC Engineer, Rose Technic, South-  
ern Engineer, Spartan Engineer, Texas  
A & M Engineer, Washington Engineer,  
WSC Technometer, Wayne Engineer, and  
Wisconsin Engineer.

The Cover: by Gerry Weltori, Industrial Designer

Automobile Air Pollution

Copyright, 1963, by Illini Publishing Co. Published eight times during the year (Oc-  
tober, November, December, January, February, March, April and May) by the Illini  
Publishing Company. Entered as second class matter, October 30, 1920, at the post  
office at Urbana, Illinois, under the Act of March 3, 1879. Office 215 Engineering  
Hall, Urbana, Illinois. Subscriptions \$1.50 per year. Single copy 25 cents. All rights  
reserved by *The Illinois Technograph*. Publisher's Representative — Littell-Murray-  
Barnhill, Inc., 737 North Michigan Avenue, Chicago 11, Ill., 369 Lexington Ave.,  
New York 17, New York.

# Less and Less about More and More

## Engineering—Tenth Ill. Export

A recent survey by the ISPE for the Governor's Board of Economic Development has shown that engineering ranks among the top ten export industries in the State of Illinois. Since January 1, 1958, 24 state firms have been responsible for engineering planning and design on \$729,978,000 in international construction.

As of last January, Illinois consultants firms had \$391,990,000 in foreign construction in process or on their drawing boards. Another \$200 million was reported as still in the planning stage.

## How Popular Are Engineers?

Most engineering students tend to feel their social status is somewhat forlorn. For these wretched souls, here is an encouraging footnote. A Gallup poll recently asked public opinion about choosing a career. "Assuming a person was qualified to enter any of the following professions, which one would you first recommend to him?" Public response was as follows:

- 1. Doctor .....23%
- 2. Engineer - builder .....18
- 3. Professor - teacher .....12
- 4. Clergyman ..... 8
- 5. Government career ..... 7
- 6. Lawyer ..... 6
- 7. Business executive ..... 5
- 8. Dentist ..... 4
- 9. Banker ..... 2
- 10. Other and don't know .....15

But the best is yet to come! College trained Americans responded as follows:

- 1. Engineer - builder .....24%
- 2. Doctor .....18
- 3. Professor - teacher .....18
- 4. Lawyer ..... 8
- 5. Business executive ..... 7
- 6. Dentist ..... 5
- 7. Clergyman ..... 5
- 8. Government Career ..... 4
- 9. Druggist ..... 3
- 10. Other and don't know .....12

Mount your white horses, engineers, and spread the word. . . . Some seem to doubt our position in society. In the educated public's eye we are held in highest esteem. . . . Could it be others are only envious?

## October 28-30 NEC Conference

Electrical engineering students should start planning early to attend the 19th Annual National Electronics Conference and Exhibition on October 28, 29, and 30 at Chicago's magnificent lakeside exposition hall, McCormick Place. The NEC is a non-profit organization chartered in the State of Illinois. It serves as a national forum for the presentation of authoritative papers on electronic research, development, application, and education.

More than 20,000 engineers, scientists, and management representatives will attend the informative technical sessions of the 1963 NEC, and will be anxious to examine and discuss new products. The Conference presents a unique opportunity for engineering students to hear the latest electronic ideas and see the newest electronic developments displayed by virtually every electronics firm in the nation.

## Illiac II Responds Again!

Gone are the "good old days" when mathematicians could idle away their time making endless calculations. After 85 minutes and  $\frac{3}{4}$  billion multiplications and additions (the equivalent of 80,000 man years; that is 160 men working with pencil and paper since the time of Columbus) the new Illiac II high-speed electronic computer has discovered and proved a new prime number. This number has 2,917 digits, and is the biggest prime number yet proved.

For those of us in doubt, a prime number is one which can be divided exactly only by itself. Prime numbers are 2, 3, 5, 7, 11, 13, 17, 19, 23, 29, and so on. The larger they become the fewer there are. Even though an infinite number of primes exist, they are increasingly hard to find because of the tremendous computation required. The previously largest known prime had 1,332 digits—less than half as many as the new one.

The only way to determine if a number is prime is to test it. Prof. Donald B. Gillies of the U. of I. Computer Laboratory programmed Illiac II to examine 400 numbers. Of these only one proved to be a genuine prime number. Although such numbers may not be of general interest to the engineer, it is an interesting and pertinent discovery to the world of mathematics. ♦♦♦

by Gary Daymon





## Our gasoline isn't good enough for some people... us

We like to think that American Oil products are the best you can buy. And they are. We also like to think we can improve the quality of our products without increasing the cost to the consumer. And we do. Consistently.

A considerable amount of work is done in testing catalysts and searching for those which will help produce the types of gasoline our customers want at the price they can afford.

One of the people engaged in the research and development of our manufacturing processes is John Mitchell, 24, a graduate Chemical Engineer from the University of Texas.

The opportunities for bright young scientists like John Mitchell are virtually unlimited at American Oil. American Oil offers a wide range of new research opportunities for: Chemists—analytical, electrochemical, physical, and organic; Engineers—chemical, mechanical, and metallurgical; Masters in Business Administration with an engineering (preferably chemical) or science background; Mathematicians; Physicists.

For complete information about interesting careers in the Research and Development Department, write: J. H. Strange, American Oil Company, P. O. Box 431, Whiting, Indiana.



IN ADDITION TO FAR-REACHING PROGRAMS INVOLVING FUELS, LUBRICANTS AND PETROCHEMICALS, AMERICAN OIL AND ITS AFFILIATE, AMOCO CHEMICALS, ARE ENGAGED IN SUCH DIVERSIFIED RESEARCH AND DEVELOPMENT PROJECTS AS:

Organic ions under electron impact • Radiation-induced reactions • Physiochemical nature of catalysts • Fuel cells • Novel separations by gas chromatography • Application of computers to complex technical problems • Synthesis and potential applications for aromatic acids • Combustion phenomena • Design and economics: new uses for present products, new products, new processes • Corrosion mechanisms • Development of new types of surface coatings.



**STANDARD OIL DIVISION  
AMERICAN OIL COMPANY**

# ATTITUDE

by Dean H. L. Wakeland

Many years ago a cave man picked up a stick. Rather than kill or destroy with it, he used it to measure with. He found that by laying it down in end to end patterns he could compare the length and sizes of various objects. In a small way he contributed to the world in which we live because he had a constructive attitude as opposed to a destructive one like many of his fellow men.

An attitude is comprised of many parts and often depends largely upon previous environments as did the attitude of the cave man. Ambition, ideals, ideas, mental ability, knowledge, health, stature and memories are only a few of these parts.

Students at the University of Illinois have, for the large part, been removed from their childhood environments in hopes of broadening both their educational and sociological experiences.

In early summer you seniors and some undergraduates will be going out from the university on many roads to seek what is to be. The knowledge you have stored will help to bring this new world into focus. The thoughts and feelings and emotions you have accumulated will control your behavior. How you put together knowledge and thoughts and actions (i.e., your attitude) will decide your standard of living, your happiness and your contribution to society.

How much knowledge have you? The sum total will surprise you, because it has come to you in dribbles year by year, grade by grade. You probably never thought of it as a thing in itself, but only by bits and pieces.

Survey its fullness. It is not only stored in factual things like dates, formulae, mathematical rules, biological data, and places but you have also stored away sensory images, appraisals, and memories of experiences. These have added to your intellect and spurred your imagination.

Now it is time to put these things to work. If you keep them locked up as a private possession—if you try to enjoy all that you have learned without connecting it to the pulsating life about you, then what you possess is not valuable property. And like real estate, if

you let it lie idle, it will slowly but surely deteriorate into nothingness.

This is not to intimate that your knowledge is complete and finished. The greatest foe you will meet in your effort to get along in the engineering profession is the temptation to allow your mind to develop the idea that you know enough. Yet every new sight and experience widens the area of your awareness of what there is yet to learn.

Besides knowledge and intelligence you have to have ability and efficiency. Ability means something more than book learning and technical skill. You might score one hundred per cent of marks in a written examination; you might have the "hang" of a routine experiment at your finger tips; but unless you display ability through craftsmanship you are not scoring one hundred per cent in your new life. And what is craftsmanship? It means doing habitually well whatever it is you have to do. You are not going to be given a seat behind an executive desk without showing some other ability than that of sitting.

"Efficiency" is a measurement of the quantity of work you produce, measured by time, and the quality of your work measured by its goodness. You are, in this new world, only as good as your performance proves that you are. Everything you do will not be a masterpiece. Even the great painters and sculptors had their uninspired days. But what you do should be workman-like, the best that you can do at the time you do it.

You have learned other certain fundamentals—patience, discipline, honesty, integrity, respect for the law, respect for proper authority, discretion, and prudence. Until now many of these have been learned under tutelage but now you are entering into mature responsibility. There have been men who were capable of governing a world, but who could not rule their own restless minds or bodies. Will you have obedience to others as well as obedience to your own principles? Will you be able to balance expectations against reality, fit into groups harmoniously, give sturdy allegiance to people and principles, and keep your balance in success or failure? Year

personal answer to these questions in the future will reflect the kind of an attitude you have.

People talk about "having an aim in life." Have you one? Is it a fast dollar or to contribute to society? Planning for the future, mapping out the route to be taken, working toward realization of your aim: all this is a part of the joy of living. The great thing is to advance, so that you feel at the end of your career that you have in some measure fulfilled the potentialities that you now believe you possess.

It is a time to raise your head so that you can see some distance. The ambitious person will take care to make a mental picture of the professional territory as well as to acquaint himself with his own possibilities and limitations. Avoid day-dreaming about a fairy country but tie your plans to realistic goals. Also avoid trivialities. To multiply ten figures by ten in your head or to compute faster on a slide rule than on a desk calculator are definite feats of dexterity of the mind and body but in itself, nothing comes of either.

Have you that quality called "enterprise?" Have you the ability to think and do things and an aptitude for action which puts this knowledge to work? "Enterprise" is not a quality needed only in industry or business but in all phases of our society—governmental agencies, armed forces, welfare organizations and universities. All the vision and desire in the world will not add an iota to your success unless you also have the energy to work.

You are entering a society which places emphasis on leisure, comfort, timekilling pursuits, sensations, fads, and novelties. It will be difficult for you to stick to your goals and shun the easy living trend. But true happiness will come only through your own self-reliance and accomplishments. People who fritter away their time are cheating themselves into bogus happiness. They are stuffing into the coffers of their one irreplaceable lifetime a senseless accumulation of trash, odds and ends, experiences, and synthetic emotions.

If you have an enthusiasm for living it will carry you through many difficulties. But enthusiasm is built on ideas, positive thinking, and on an active life. Every visible successful act is first of all an invisible thought which only actions and application bring into being.

In this rambling account are a number of qualities which form your attitude. As you enter the mature phase of your life—the responsible productive phase—the most important thing you can possess for your employer, yourself, and society, is a right attitude. Will you be able to think beyond your environment and training with a constructive attitude, like the cave man did? ♦♦♦



# THE BELL TELEPHONE COMPANIES

## SALUTE: TOM HAMILTON

When the Bell System recently product-tested the new Touch Tone telephone in Findlay, Ohio, they called on Ohio Bell's Tom Hamilton (B.S.E.E., 1960) to coordinate the project. Quite an honor since this was one of two Touch Tone trial areas in the entire country.

This happened on Tom's second assignment with the company. Since completing the project, Tom has joined the Fundamental Planning Engineer's Group. Here he

makes engineering economy studies and submits programs for capital expenditures. Tom's performance has earned him the opportunity to attend a special six-month Bell System engineering course in Denver.

Tom Hamilton and other young engineers like him in Bell Telephone Companies throughout the country help bring the finest communications service in the world to the homes and businesses of a growing America.



### BELL TELEPHONE COMPANIES

TELEPHONE MAN-OF-THE-MONTH



# RAILROADS

by Thomas Osika

At the turn of the nineteenth century, railroads provided the only effective means of mass intercontinental transportation. In fact, the railroad industry virtually monopolized all long and short distance hauling merely because they had no competitors. As the automotive, inland water carrier and pipeline industries grew, the railroads' monopolies began to disappear.

By 1945, railroads were still the king of transportation, but the efficient and flexible trucking companies began presenting serious competition (especially on shorter hauls). As a result, railroads were forced to keep only an auspicious, steady business volume even though total national business had grown. In general, since 1945 the percentage of railroad business has been steadily declining.

#### Railroad Modernization

Railroads are now developing specialized cars in an attempt to compete eco-

nomically with other modes of transportation, to regain lost freight and to satisfy individual shippers. The specialized car is normally specifically designed for only one product. Its chief advantage is its increased size, and loads of one hundred tons, almost twice the capacity of older cars, are not uncommon for new cars.

#### Size Advantages

Size advantages can be explained best by stating an economic law in railroad-ing: As the capacity of a car increases, profit also increases. This is rather obvious since it is easier to deploy one 100-ton-capacity car costing \$25,000 than two 50-ton-capacity cars, each costing \$15,000. Increased size results in a two-fold profit increase: a decreased material cost for each car and a relative payload increase. In the newer cars the dead-load to payload ratio is lowered. Like-

wise, it is reasonable to assume that the larger car has a greater payload volume. In general, this necessitates more profit, but simultaneously, engineering problems involving excessive stresses on car wheels and rails are introduced. These will be discussed later.

#### "Monster" Tank Car

Before the rail-wheel problem is pursued, consider a new and interesting body design which has been successfully used on a tank car (See figure 1.) The body of this car was built to carry its own load; it has no conventional under-frame. The General American Transportation Company built the 30,000 gallon capacity tank car, which is about twice as long as the old "standard" tank car. With the tremendous increase in the unsupported body span and the increased load-carrying capacity (70 tons vs. approximately 40 to 50 tons) this car is an all-around success.



This General America Transportation Company tank car has a capacity of 30,000 gallons and is about twice as long as the old tank cars.



## Recommendation of Joint Committee on Relation Between Track and Equipment

April 29, 1959

### Maximum Load on Wheels of Various Diameters

Nominal Wheel Diameter	Lbs. per Inch	Wheel Load
33 inches	800	26,400
36 inches	810	29,200
38 inches	820	31,200
40 inches	825	33,000
42 inches	830	34,900

**Exceptions to be permitted for a limited number of cars for heavy loads  
which shall be subject to approval by Mechanical Division, A.A.R.**

#### Other Applications

Fortunately, such designs are not limited to tank cars. If the same materials, design features and load weights (the only general considerations for any body design) are used as in GATC's monster tank car, it is reasonable that any load can have its own car.

Since the underside can be designed to accommodate wider, longer unloading mechanisms, the unloading time is shortened by utilizing the latest unloading devices. In the case of tank and hopper cars, a series of valves or wide-swing doors not only speeds up unloading but also decreases the "turnaround" time. From an economic standpoint this is very important for efficient utilization, since the new car can be used more times. For instance, Pullman-Standard has a hopper car with 40' x 2' unloading mechanisms. It can be loaded with 3,000 bushels of corn in 12 minutes and emptied in 2 minutes and 40 seconds. The total weights of this type of payload is approximately 168,000 pounds.

#### Size Problems

Current trends toward increased payloads per car introduces two major problems: wheel-rail damage and incompatible coupler heights. The new, larger and heavier cars produce greater stresses on rails. Present track steels allow shear stresses of 40,000 to 45,000 psi. If a new car carries a 160,000 pound load, each one of its eight wheels supports 20,000 pounds. Ideally, the contact between wheel and rail produces no stress area (point contact).

Practically, the wheel and rail are deformed enough to produce an elliptical stress pattern of approximately 0.2 — 0.4 square inches depending upon the weight of the total load. This deformation produces a stress range of

50,000 — 67,000 psi, which exceeds the present allowable stress limit by 10 — 15%. Obviously, either the strength of the wheel and rail must be increased or other solutions must be found.

Fatigue considerations cannot be overlooked. Experimental evidence shows that stresses greater than 50,000 psi produce fatigue failures at approximately 16,000,000 cycles. A larger increase in stress (to 51,500 psi) induces failures at 4,000,000 cycles and a 71,500 psi stress causes failures at only 1,150,000 cycles. The method of fatigue loading during the test was complete reversal. This test reveals that with greater wheel loads, rail life is decreased, and the safety factor concept is non-existent.

Plastic flow in rail heads is also a common occurrence. Simple distortion experiments were conducted and it has been shown that current loads produce compressive, tension and shear stresses which exceed yield stresses. Copper pins are inserted in the rail head at right

angles to the surface. (See figure 3.) The rails are used for several years and then removed for inspection of the pins. The bending of the pins in the direction of flow of metal is quite evident, thus establishing the fact that present wheel loads are producing stresses far beyond the yield point of the metal.

#### Increased Rail Sizes

Several attempts have been made to reduce rail stresses. One suggestion is increased rail size. This idea is unsatisfactory since the cost of rails would increase proportionately with the additional steel needed, and it would not be economical to replace the old rails.

Likewise, a larger rail would not be justified since it produces exactly the same function as a smaller rail. Rails are designed with a convex surface for minimum rail-wheel contact. This particular geometric configuration reduces wear, friction, and flattening of the surface. Now consider the smaller and larger rail carrying the the same load. Regardless of the size of the rails, the actual deformation between the rail and wheel produces the same elliptical area. The stresses incurred are identical, provided the same materials are used. Therefore, absolutely nothing is gained by increasing the rail size.

A larger rail requires special heat treatment. Heat treating of the metal decreases rail distortion since the rail is hardened, and the yield point is therefore raised. This is desirable, since the yield point increases, the metal becomes more brittle, and the fatigue properties are unsatisfactory. Therefore, what is gained in one way is lost in another. Still worse, the heat treating process costs 50 per cent more than standard rail production methods. Rail costs are currently about \$115 per ton and \$65 per ton must be added for heat treating, thereby making this solution economically undesirable.

#### Greater Wheel Diameters

Now consider a satisfactory solution. Either the load per wheel must be de-

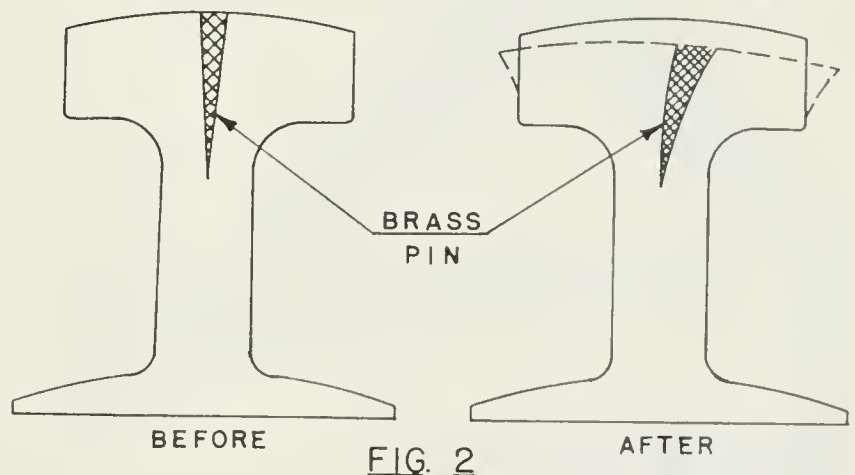

FIG. 2

creased or the wheel diameter must be increased with increasing loads. Decreasing the load per wheel cuts the payload per car; therefore, this is undesirable since the objective is to increase payloads. Mathematical equations governing wheel diameters and loads have been developed. These indicate that internal stresses within the wheel and rail decrease in direct proportion with a decrease in load, but in even greater proportion with an increase of wheel diameter. Suggested wheel loads and diameters will no doubt be a common sight on newer cars, since this seems to be the only practical solution thus far considered.

#### Coupling Complexities

If wheel diameters increase, the height of the coupling mechanism increases also. This is easily understood. If the car remained at one height, the cushioning mechanism of the coupler would occupy the same space as the raised wheel axle; obviously, an impossible situation. Furthermore, present car designs consider the coupler mechanism as a part of the body rather than a part of the wheel assembly. This means that every time a larger wheel is used, the body must be redesigned to accommodate a coupler of standard height.

Presently, train loads consist of many

varied products, but future plans suggest the intensive use of the integrated train concept—a whole train of high capacity cars which will carry only one product. Since couplings between these new and old cars are inevitable, couplers heights must be considered. The purpose here is to suggest a truck design philosophy which will permit new and old cars to be coupled. This truck design integrates the cushioning mechanism, and the dependence of coupler height on wheel diameter disappears exists since the couplers are no longer a part of the bodies but rather a part of the trucks themselves. Thus couplers can be kept at a standard height regardless of wheel size and without interference between coupler and axle positions.

Fundamentally, future redesigning for still heavier loads is unnecessary. If heavier loads are in demand, the body size increases and so does the wheel diameter. But since the body and truck assembly can be separated, the body no longer needs to be designed around a coupler height. The trucks (now including the coupler mechanism) will increase proportionately in size, and all coupler heights are consistently standardized with the rising load trends. Designs for optimum size of load and for variable wheel sizes can then be made without any concern for interference of opera-

tional elements.

To omit the other recent advances in new designs would be an injustice to the railway freight car industry. The most significant of these advances is the use of more functional materials such as stainless steels, aluminum, resins, plastics, spray foam insulators, reinforced concrete and fiberglass.

Mr. Nervi, new car design experimenter, claims that a reinforced concrete body is stronger than a steel body when the weight of the two materials are compared. In general, the body is easily made by applying cement to preformed steel reinforcing. The process is similar to lathe plastering.

Plastic and fiberglass bodies also help to solve the weight and corrosive problem while resins and fiberglass provide a better lining for carrying liquid acid products.

The research possibilities for efficient railroad car designs are unlimited. A wide variety of materials which have been known for many years are only now being utilized. However, additional research will be necessary to find the best combination of material and body design for the transportation and protection of a specific product. With these new ideas and others, the railroad may again become the king of transportation.



## CIVIL ENGINEERS:

**Prepare for your future in highway engineering—get the facts about new DEEP-STRENGTH (Asphalt-Base) pavement**

Modern pavement engineering has taken a "giant step forward" with DEEP-STRENGTH Asphalt construction for new roads and streets. There is a growing need for engineers with a solid background in the fundamentals of Asphalt technology and pavement construction as new Interstate and other superhighways in all parts of the country are being built with advanced design DEEP-STRENGTH Asphalt pavement.

Your contribution—and reward—in our nation's vast road-building program can depend on **your** knowledge of modern Asphalt technology. So prepare for your future now. Write us today

**THE ASPHALT INSTITUTE**, College Park, Maryland



**THE ASPHALT INSTITUTE**, College Park, Md.

Gentlemen: Please send me your free student library on Asphalt Construction and Technology.

NAME \_\_\_\_\_ CLASS \_\_\_\_\_

ADDRESS \_\_\_\_\_

CITY \_\_\_\_\_ STATE \_\_\_\_\_

SCHOOL \_\_\_\_\_



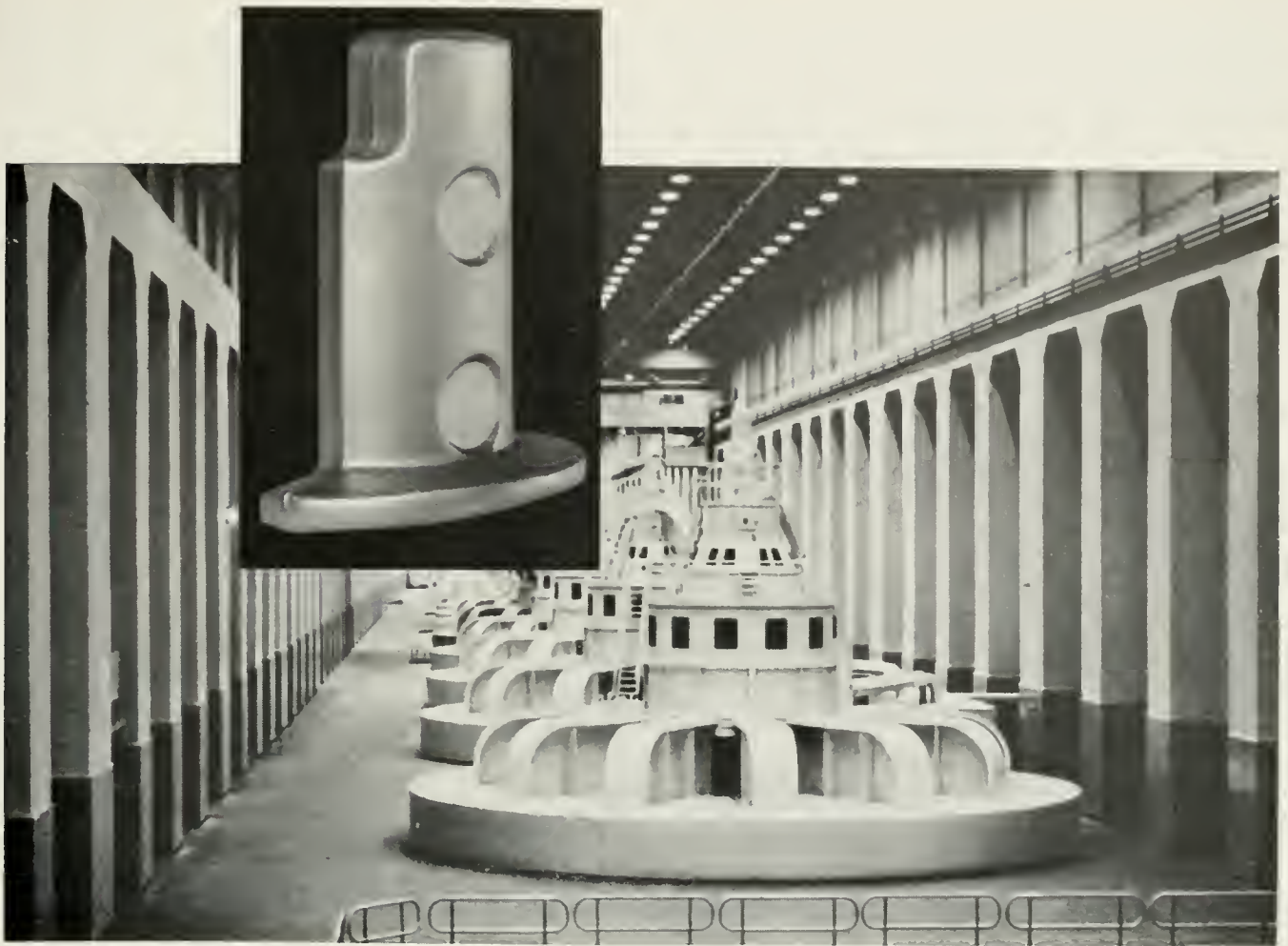

## **FORGED...**

**to provide more strength at 60% less cost**

You are looking at a simple forging. It will be machined slightly to make a rotor end-plate for a giant hydroelectric generator. This part must withstand radial loadings of 150,000 pounds on the coil-support surface as the 30-foot rotor spins.

Why use forgings for generator end-plates? Because forgings possess many special properties. The forging process is unlike any other, because forged parts start with refined metals, can be given almost any desired shape between impression dies under enormous pressure or by consecutive blows. Forging imparts added strength and toughness, permitting weight-saving design, reduced cost, greater safety in our high-speed world.

Continuing research and modern equipment of the forging industry have a major part in helping

extend the ability of metals to withstand the ever-increasing stresses and temperatures and pressures created by today's dynamic civilization. Forged parts withstand the landing impact of a jet aircraft, yet are light and strong to reduce dead weight. Forged parts help restrain the tremendous pressures and temperatures of modern petrochemical equipment. They improve the performance of vital automobile components.

Forging has reduced the *cost* of many parts, too. Production developments in the forging industry often make forged parts *cheaper* than parts produced by other methods. Let us send you case histories of parts converted to forgings from higher cost methods. Address: Drop Forging Association, Dept. E1, 55 Public Square, Cleveland 13, Ohio.

For more information, see our 4-page, full color advertisements in these magazines: MACHINE DESIGN, PRODUCT ENGINEERING, STEEL, MATERIALS IN DESIGN ENGINEERING and AUTOMOTIVE INDUSTRIES.

*When it's a vital part,  
design it to be*

**FORGED**

# LASER MACHINE TOOL

by Art Becker, EE '66

Efforts to apply lasers to machining and welding operations began soon after the laser's introduction in 1960. It must be stressed, however, that the laser is still being developed and more research and design will be necessary before the laser becomes a profitable machine tool. At present, the three major laser development areas are: laser materials, laser flash lamps or "pumps" with their electrical supplies, and the optical system.

A laser is a source of nearly coherent, monochromatic optical radiation which can be of high energy. The word LASER stands for *Light Amplification by Stimulated Emission of Radiation*. Figure 1 represents a typical ruby laser apparatus for pulsed operation. A capacitor bank (energy storage system) is charged from 3500 to 10,000 volts by a dc power supply. The pumping system is a flash-tube similar to the tubes used in photographic "strobolights." A sufficient amount of energy is absorbed and re-emitted by the laser material in a narrow beam which is monochromatic, coherent, and of very high power. A lens or mirror system further focuses the beam (and increases the energy density on the workpiece), and the amplified light beam melts or vaporizes the target material as in Figure 2.

The laser operates on the basic theory governing the behavior of electrons in various energy levels. Under some conditions, an electron in an excited state  $E_2$  can be stimulated or forced to fall

back to a level  $E_1$  and emit energy  $E_2-E_1$  by again being struck by an energy  $E_2-E_1$ . Most lasers now in use are based upon the absorption of optical radiation over a band of wavelengths to excite electrons in the laser material to an excited state from which there is a rapid decay to a state possessing a much longer lifetime, called a metastable state. In stimulated emission or laser action, the electrons in the metastable state are caused to decay together in phase. In order for this to happen, there must be a population inversion (i.e., there are more electrons in the metastable state than there are in the state to which the electrons decay).

Various conditions that contribute to the total efficiency state are defined in terms of the metastable electron state, and are lumped into the term "pumping efficiency." The first necessary condition is the required width of the absorption bands, or, more simply, the range of wavelengths that may be absorbed and thus cause an electron to land in the metastable level. Ruby, currently the most efficient laser material, has two such bands: one at 5500A, about 500 A wide, and one at 4100A, of about the same width. The second condition is termed "quantum efficiency," and refers to the percentage of photons absorbed from the pump thereby causing electrons to move to the metastable level. Most laser materials have quantum efficiencies from 70 to

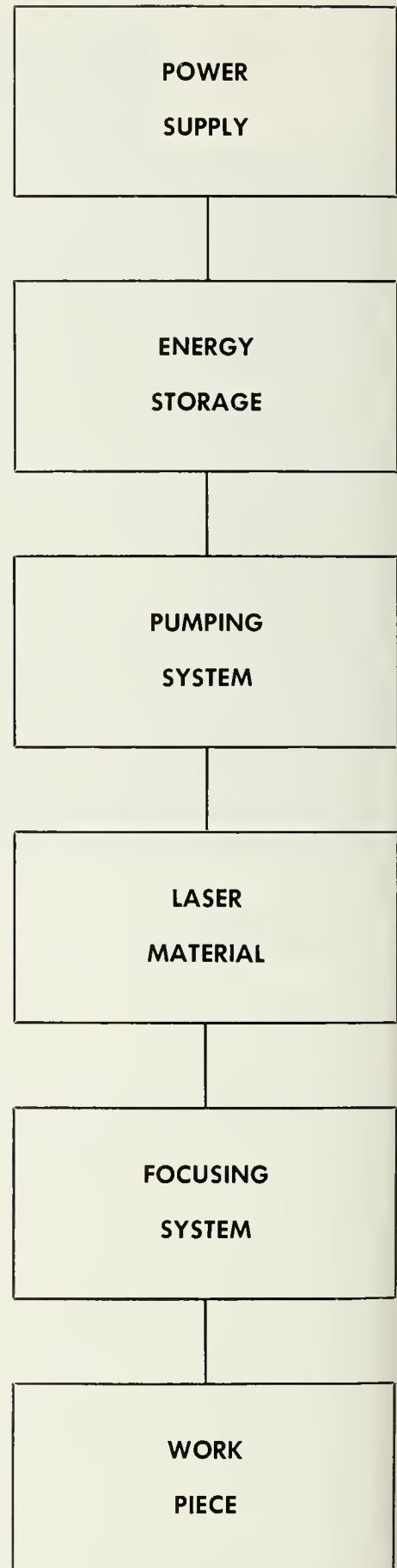

Figure 1. Schematic diagram of Laser Head and Work Piece.



100%; their efficiency normally is a function of temperature, which increases with decreasing temperature. Lastly, a condition of limiting energy efficiency refers to the ratio of the energy of the output light to that of the absorbed light. Ruby absorbs light of wavelength 5500Å (energy 2.35 eV) and emits radiation of wavelength 6940Å (energy 1.8 eV) for an efficiency of 80%.

Ruby has been mentioned as a laser material, and the properties and characteristics which it possesses are important in the consideration for application of any laser material. These include the wavelength of the pumping band and the output wavelength, the lifetime in metastable state, the strength of the pumping absorption line, the operating temperature, the resistance to thermal shock and optical bleaching, and the homogeneity and perfection of the material. The cost and availability of laser materials is changing very rapidly as new materials are developed. Those crystals possessing desirable properties are quickly brought to market by a number of firms, thereby reducing the price.

Probably the weakest link in present laser systems with the most limited life, particularly those using ruby, is the flash lamp used as a pump. The helical or linear xenon-filled lamp of the photographer, with slightly more rugged electrodes, is still the standard laser pump. Its life depends largely upon the operating level. As most lasers require quite considerable input energy to generate 10-15 joules of output, the lamp is stressed accordingly.

The lifetime and the average power-handling capability of the flashtube become crucial, particularly if the pump-laser efficiency is relatively low. Using a single 2000 joule lamp in an elliptical reflector with the lamp at one focus and a large ruby rod at the other, one laboratory obtained an output of 20 joules for an overall efficiency of 1%, one of the most efficient high power systems yet reported. The life of the pump under these conditions was approximately five or ten shots. Two obvious disadvantages of laser pumps are the low efficiency and the prohibitive expense-output ratio. If a 2% efficient pump is used, the other 98% of the energy must be removed as heat, and this cooling is extremely difficult. The whole area of laser pumps needs further research and development for laser machining to become a practical, inexpensive tool. A \$100 lamp lasting five to ten shots may be suitable in a research laboratory, but it would be economically prohibited for most industrial uses.

Westinghouse has developed a unit called the HD-6, which is capable of handling the largest lamps and can run repetitively at a high rate at the lower energy levels. The voltages and energies required to operate the unit are lethal,

and involve the incorporation of extensive interlocks and safety switches. The laser head is a universal mount around which a nitrogen gas stream (about 100 to 150K) is vented. The stream forms a dry window in front of the laser rod, preventing moisture condensation on the end of the rod. Both the safety system and the cooling system are significant advances toward improving the efficiency of laser pumps.

#### Laser Optics

An aspect of laser technology receiving much attention is laser optics. The field involves the reflecting system of the laser proper and the lens or mirror elements necessary to focus the nearly collimated beam from the laser.

The most common reflecting system is one in which the ends of the laser rod are polished flat and are plane parallel. Another technique gaining wide acceptance, however, is the use of confocal reflectors of "resonators." There are two major advantages of this scheme over the plane parallel reflectors: the optical alignment is much less critical and spherical surfaces are easier to fabricate than plane surfaces.

For machining applications, an optical system is used to focus the monochromatic light of the laser upon the workpiece, but there are limitations on the extent to which this is successful. In actual practice, the spread of the laser beam limits the degree of focusing.

#### Laser vs. Electron Beam

Thus far, only the hardware of the laser has been discussed. The laser apparatus and its machining uses are best appreciated by a comparison with electron beam machining, to which laser machining is most similar. At the present state of laser development, the relative cost of laser machining as compared with electron beam machining can only be sur-

mised. If it is assumed that laser development will result in the construction of laser machines with the same general power delivery abilities as present electron beam machines, future costs can be compared.

Electron beam machines which fulfill these needs cost an average of \$50,000 to \$175,000. Large laser systems capable of delivering the power densities required now cost about \$25,000. It is expected that repair costs to laser systems using large capacitors would be relatively high because of capacitor replacement.

The difference most often quoted between lasers and electron beam machines is the necessity of having and using a vacuum enclosure with the electron beam. Certainly, the lack of a vacuum system is the major advantage of the proposed laser machines, since between 10 and 50% of the time spent with the electron beam machines is used in the operation of the vacuum system. Thus, in those areas of interchangeability, the laser will enjoy an operating cost advantage over electron beam. The maintenance of the laser will also be less by the omission of vacuum equipment.

Thus, lasers that can be used as machine tools will cost about the same as an electron beam machine, with possibly some downward adjustments for the exclusion of a vacuum system, on the other hand, operating costs of lasers will perhaps be less than that of electron beam, again primarily because of the vacuum systems, depending upon capacitor and pump life.

It is not believed, however, that lasers will supplant electron beam machines when powerful lasers are built. Rather, each of the two systems will be used in those areas which fit its capabilities best.

◆◆◆

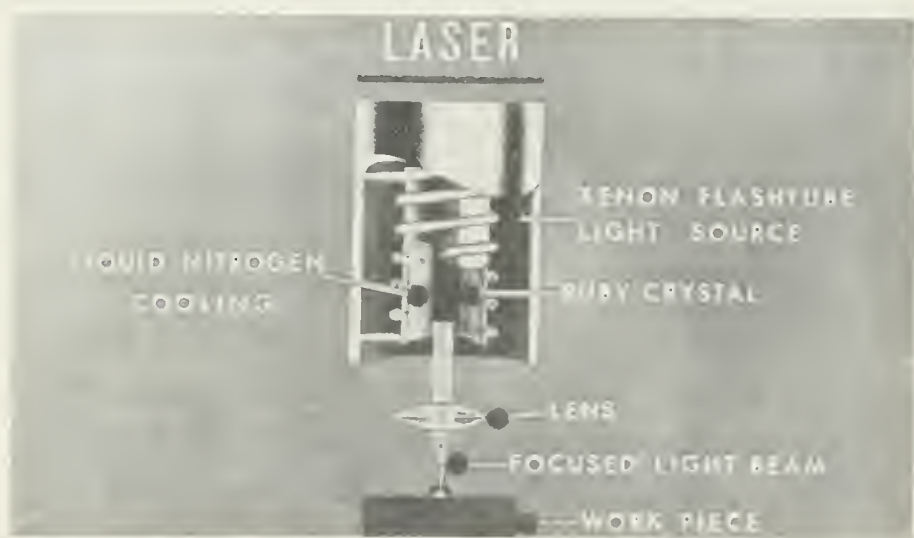

Figure 2. Typical Laser apparatus for pulsed operation.

# An Engineer Speaks

(Edited by Stuart Umpleby from an interview with Carl E. Reistle, president of Humble Oil, printed in *The Oil and Gas Journal*, April 29, 1963.)

Industry today needs more engineering talent, not more engineers. Computers and automatic equipment allow the engineer to do more work and to create more in a given time; so it follows that to do the same work from one year to the next requires fewer people. The only reason for a company to have the same number of engineers—or more—is that it is an expanding company. Engineering graduates are facing greater competition as well as the demands placed upon them by the increasing complexity of their profession.

## Better Training

I would like to see universities adopt a five-year engineering course. The first four years would provide a broad engineering background; the fifth would be a year of specialization. By this I do not mean the trade-school type of specialization. If a man were thinking of going into production, he might take advanced courses in hydraulics or thermodynamics. If it were refining, he would want some advanced organic chemistry.

A man with a good engineering education can move from one phase of the industry to another. We don't really divide engineers into, say, petroleum and chemical engineers. That is a kind of specialization we'll see less and less.

## Counseling

The unfortunate thing about young engineers is that they don't take advantage of the counsel that is available to them. A great characteristic of the human being is a desire to share his knowledge. A young man can get worlds of sound advice—if he has an inquisitive mind.

## Keeping Up

An engineer should spend one-fourth of this time—his own time—keeping up with his profession. An engineer has as much responsibility to keep up to date as he had in getting his original education. It is not the company's responsibility. Dr. Thomas Stelson of Carnegie Institute of Technology has estimated that new knowledge replaces past engi-

neering training at the rate of 10% a year, and that a graduate loses his college training through disuse or "decay" at the rate of 10% a year.

If this is true, and I believe it is, then an engineer must increase his knowledge at the rate of 20% a year just to remain of the same value to his company.

But to advance, an engineer must increase his value to the company, and that is why I say he should spend 25% of his own time in furthering his professional knowledge.

All kinds of material are available—through professional societies, through libraries, by keeping in touch with old college professors. The engineer who succeeds is the one who takes advantage of engineering news material.

## Keys To Advancement

Other than keeping up, certain attributes are essential to advancement.

- 1) Moral integrity
- 2) An inquisitive mind
- 3) Ability to communicate with others—to get their cooperation. He must sell his ideas and he must convince people of the value of the results he hopes to achieve.
- 4) The desire to accomplish things without asking, "What's in it for me?" This means seeking opportunities for using his talents and abilities. It means putting extra time and effort into a job. The man who leaves work 10 minutes early isn't going as far as the man who leaves 10 minutes late.
- 5) An interest in his work
- 6) Good judgment

Those who demonstrate these qualities promote themselves.

## Management

A company's greatest assets are its people, and the biggest challenge to management is the effective utilization of men. Management has an obligation to give its men an opportunity to create. The man who isn't being challenged by his job is deteriorating, and no company succeeds by carrying a bunch of dead-heads.

## Social Responsibilities

If an engineer develops an idea to do a 10-man job with only three men, he should also concern himself with the



Carl E. Reistle, Jr., president of Humble, the nation's biggest oil company, still thinks of himself as an engineer. Upon graduation in 1922 from the University of Oklahoma as a chemical engineer, Reistle joined the Bureau of Mines. In 1933 he became chairman of the East Texas Engineering Association, conducting reservoir studies which later led to the huge East Texas field pressure-maintenance program. He joined Humble in 1936 as assistant chief petroleum engineer, advanced steadily, and became president of Humble in 1961. He was president of the American Institute of Mining and Metallurgical Engineers in 1956.

other seven. He should ask himself, "Where can we use these men? Can they be trained? Should we consider early retirement?" He is usually the first to know of the new problem being created, and there's no reason for him to pass all the responsibility to other segments of management.

There is more to automation than technology. If an engineer automates people out of jobs, then he should work with management to see what might be done with the surplus. The engineer should feel obligated to participate in solving the problem he is creating.

## Smaller Work Forces

In the future we will be using fewer people for the same amount of work. This trend toward reducing work forces is not over and never will be. But we soon will have one million people in the United States, and to render the same service to the public will require us to expand. The economy is growing, and even if we merely maintain our position, we must grow. ♦♦♦



**\$60 Million Outlay in Few Years Expected**

By CHARLES A. KELGAN, Business Editor  
Picture on Page 18  
The Atomic Energy Commission (AEC) today awarded a contract for construction of a mobile military reactor to Allison Division of General Motors. The contract puts Allison in the nuclear field as a prime contractor, a move of unusual significance to the Midwest and Indianapolis. Allison officials said the contract is expected to involve an expenditure of over \$60 million over the next few years.

**Allison Will Build Mobile Atom Plant**

**Allison Awarded Atomic Contract**

**Allison Expands For Nuclear Work**

**\$60 Million Is Estimated for A-Power Generator Production**

The Atomic Energy Commission awarded Allison Division of General Motors a contract to design and build a mobile atomic power generator. The award, which may amount to \$60 million, is the largest power generator contract ever awarded in the field on a mobile atomic power plant. Allison officials said the award makes the company a prime contractor in the field on its first major atomic power plant and that the contract is a significant step in the company's expansion into the nuclear industry.

**In Step With the Times**

Allison's \$60 million contract to develop small atomic generators is an invigorating boost for Indianapolis and Indiana. In addition to its obvious impact on the local economy, the project is a national complex here which already is remarkably and reassuringly varied. It also provides a rebuttal to the gloomy prophets who predicted the demise of the atomic industries of the Midwest. This project is right where it should be, and it is exciting, lively, and it will bring to the area many of the new and research experts.

**Allison Lands Key Nuclear Contract**

**GM gets Army contract to develop mobile nuclear reactor for field use**

The Army is expanding its efforts to develop a mobile nuclear reactor for field use. Allison has just been awarded a contract for the \$40-million job of developing an atomic power plant for field use. The reactor will be built by GM's Allison Division in Indianapolis, generating 1000 kw of electricity. That reactor, the output of the AEC's mobile nuclear reactor already being developed, is expected to be the same as the one being developed by Allison.

**A Widening Circle**

Allison is a member of the Atomic Energy Commission's mobile atomic power generator project. The project is a significant step in the company's expansion into the nuclear industry. Allison officials said the award makes the company a prime contractor in the field on its first major atomic power plant and that the contract is a significant step in the company's expansion into the nuclear industry.

● Award of a multimillion-dollar contract to Allison by the Atomic Energy Commission for construction of a mobile Military Compact Reactor highlights the progress Allison is making in energy conversion programs.

Objective of the high priority project is the design, construction and operation of an extremely mobile, lightweight powerplant capable of generating 3000 kw. of electricity. The plant will have a high temperature, liquid metal-cooled reactor coupled to a power conversion system. In addition to its military field use, the MCR could serve as a power source in civilian defense and power failure emergencies. Allison, the energy conversion Division of General Motors, was selected by the AEC as prime contractor on the basis of company capability to act as systems manager for the complete project.

In other fields, first and second stage rocket motor cases designed and produced by Allison for Minuteman have achieved a 100 per cent reliability record. Too, Allison research has made significant progress in the development of cases from lighter weight materials, titanium and plastics, and now is in position to meet the case needs of the future . . . whatever they may be.

Allison also maintains its position as foremost designer, developer and producer of turboprops. Current emphasis is directed toward developing engines of greater power with maximum fuel economy, and without increasing engine size.

Acceptance by the Army of the Allison 250-horsepower T63 turbo-shaft engine for Light Observation Helicopters is further evidence of Allison capability in the gas turbine areas.

Perhaps there's a challenging opportunity for you in one of the diversified areas at Allison. Talk to our representative when he visits your campus. Let him tell you first-hand what it's like at Allison where "Energy Conversion Is Our Business."

**Allison**  
THE ENERGY CONVERSION DIVISION OF  
GENERAL MOTORS, INDIANAPOLIS, INDIANA

An equal opportunity employer

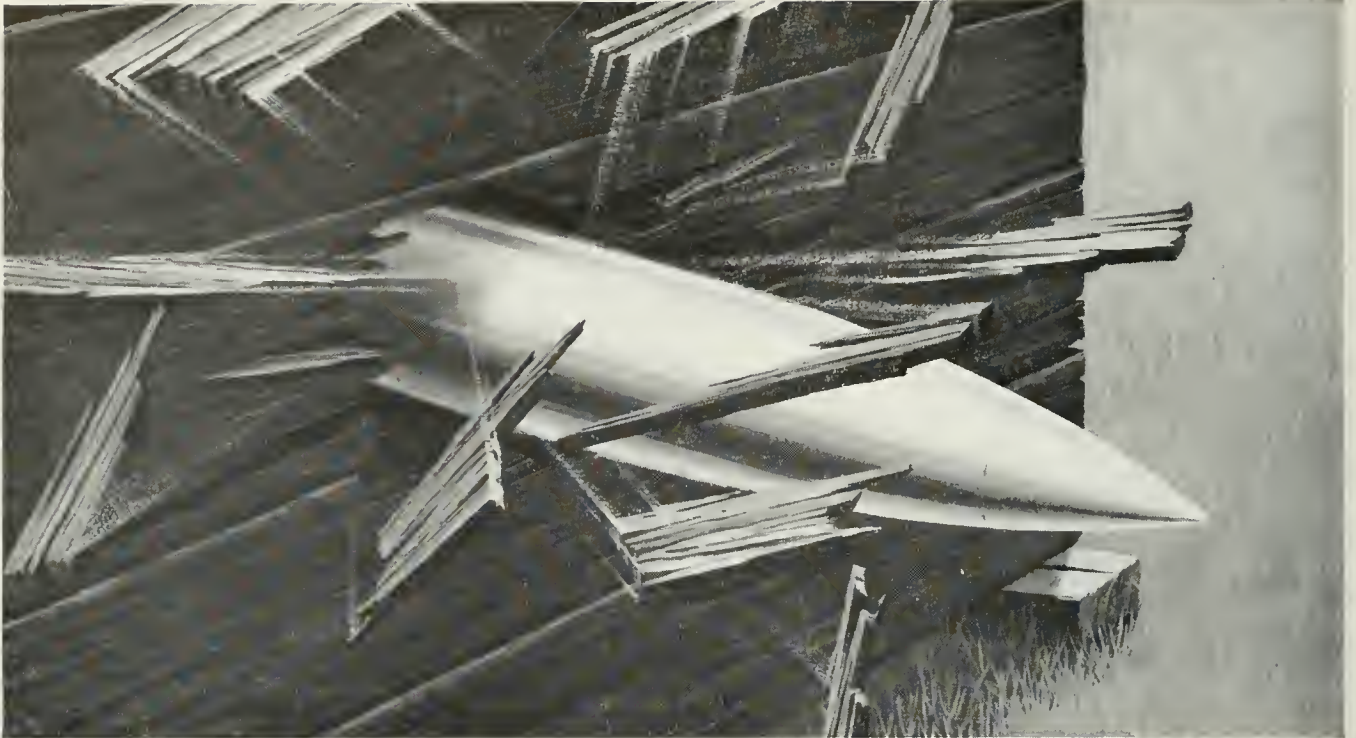

**Malleable artillery shell pierces 2 feet of solid oak at a velocity of 2,000 feet per second. In U. S. Army tests, pearlitic Malleable 105 millimeter shells were fired at 112% of rated maximum pressure. The new Malleable shells pierced the solid barricade, performing to the exacting requirements of the specification . . . proof of STAMINA.**

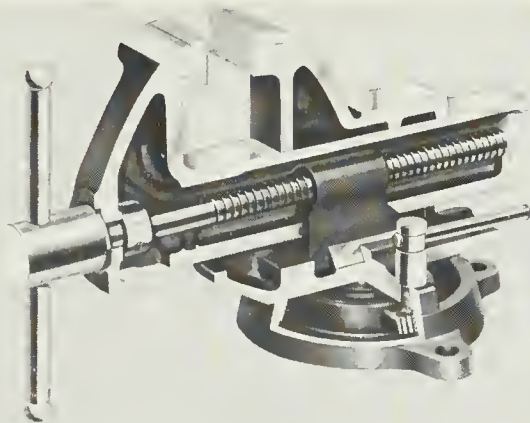

**"Guaranteed for Life"** is the hallmark of confidence the manufacturer of this vise has had in its all-Malleable housing since first designed in 1917. These machinist's vises really earn their reputation as the most abused tool in the workshop, and about one million are now in use. All carry this unconditional guarantee . . . proof of STAMINA.

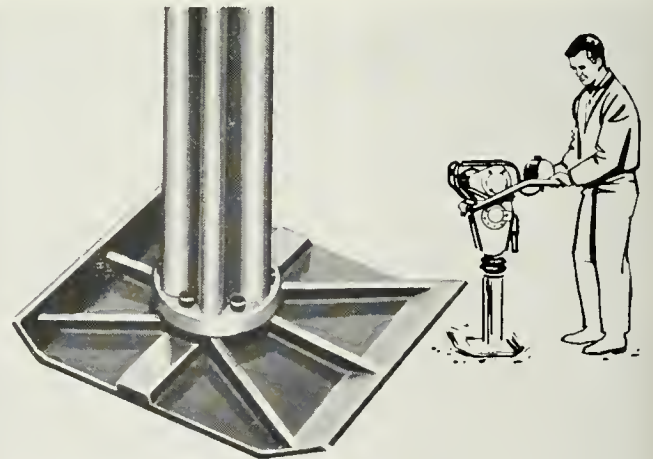

**Pearlitic Malleable shoe for air-powered compactor delivers 900-pound blows at the rate of 350 per minute. Day after day, month after month, this rugged casting batters away on dirt, gravel, clay and rocks without significant wear or damage . . . proof of STAMINA.**

# Add Greater Stamina To Your Products With Malleable Castings



**Your Free Copy** of Malleable Engineering Data File is now available from any member of the Malleable Founders Society. Or write to Malleable Founders Society, Union Commerce Building, Cleveland 14, Ohio.

For more detailed information on how Malleable castings can improve your products, call any of the progressive companies that display this symbol —





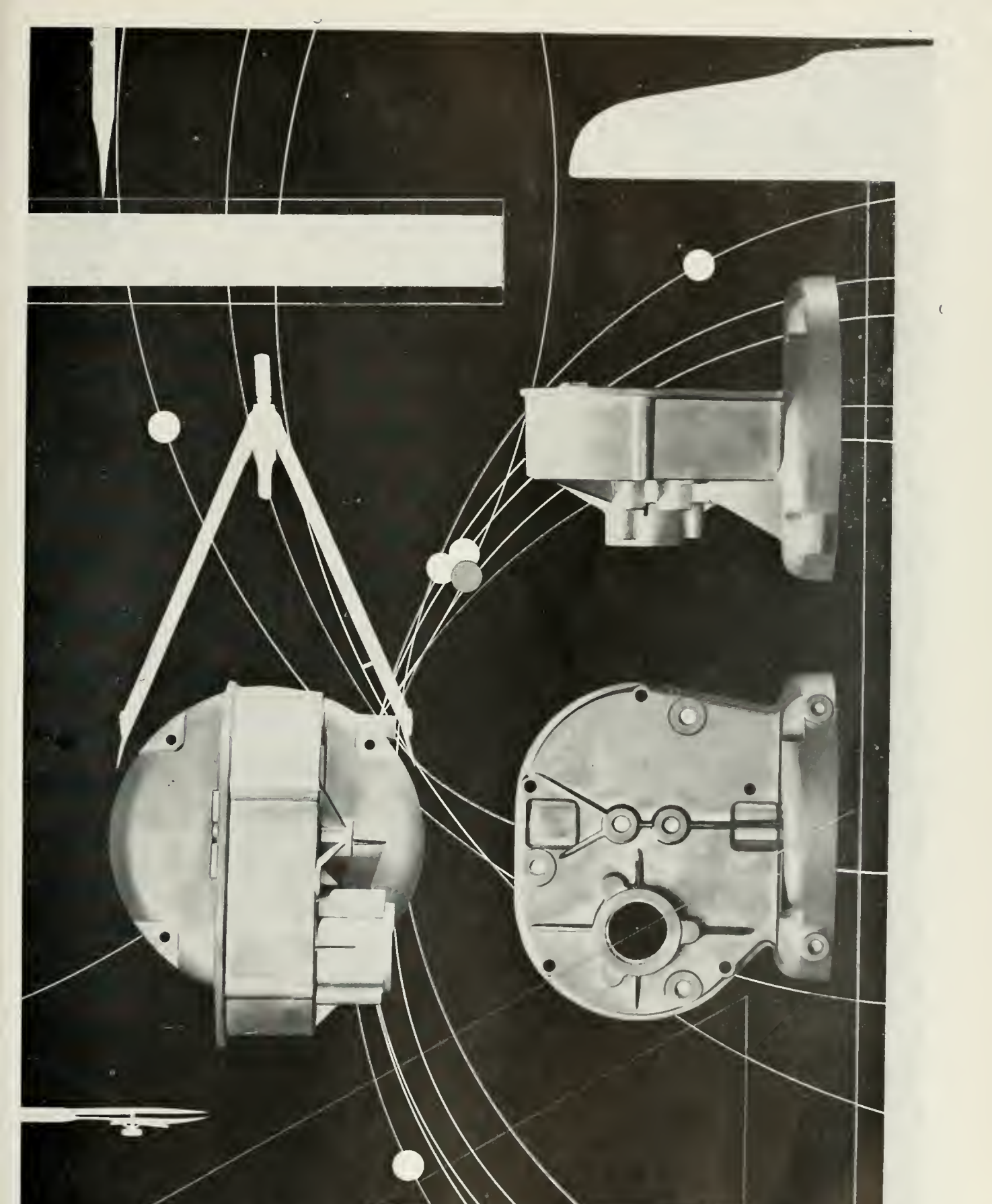

*New Products Corporation*

CUSTOM DIE CASTINGS SINCE 1922 / BENTON HARBOR, MICHIGAN

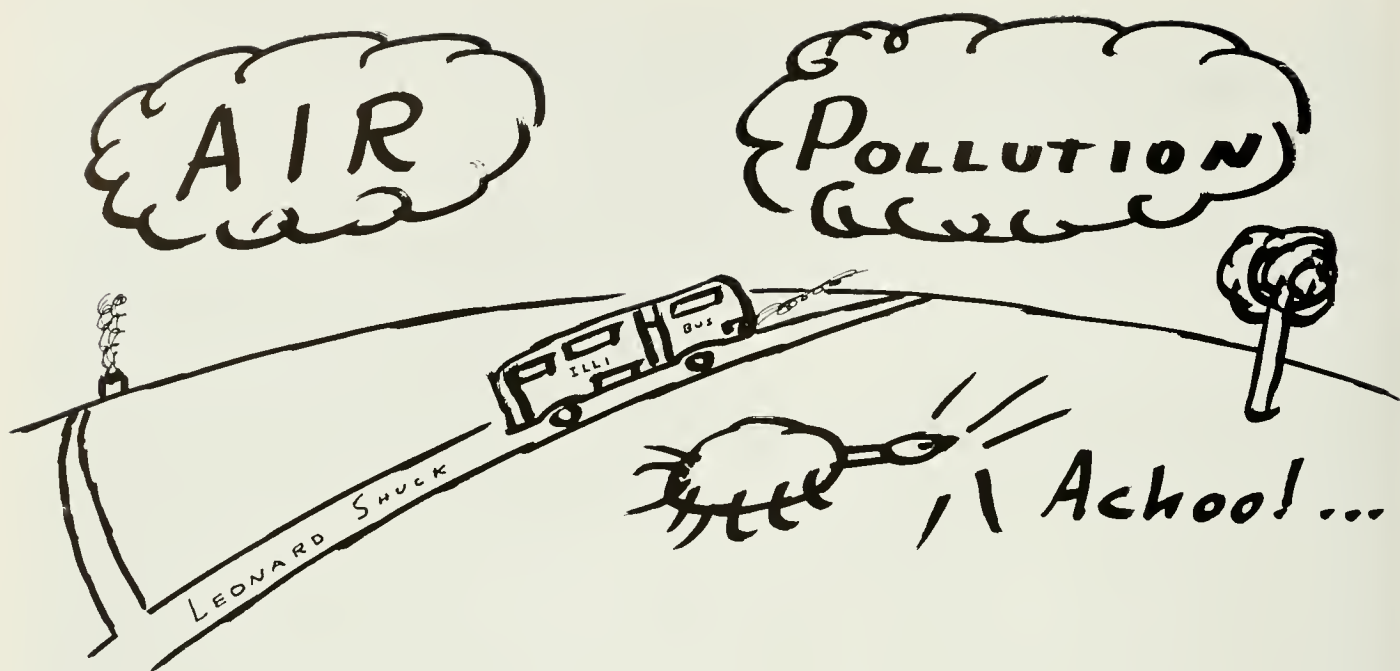

How many of you awaken thoroughly refreshed only to be greeted with those persistent Illi Bus fumes? Yes, our atmosphere is no longer the flower-scented paradise our forefathers once enjoyed. Maintaining a healthful atmosphere is becoming increasingly difficult in today's industrial society. Many industrial processes (including Illi Busses) pollute the atmosphere to such an extent that uncomfortableness, sickness, and even death are common.

Atmospheric pollution is not a new problem. Air pollution laws date back to the thirteen hundreds when attempts were made to control the smoke and soot which resulted from the incomplete combustion of coal.

Only during the last twenty to thirty years, however, has it become a serious, and often fatal, problem. Thousands of tons of sulphur dioxide, nitrogen dioxide, ozone, carbon monoxide, hydrocarbons, and other pollutants are poured into the earth's atmosphere daily by various industrial processes and automobile engines. These impurities have affected not only the public health but surrounding vegetation and animal life as well.

A number of disastrous air pollution incidents have occurred within the last 35 years. In 1930, in the Meuse Valley of Belgium, 6000 became ill and 60 died; in Donora, Pennsylvania, in 1948, 6000 became ill and 20 deaths occurred; in London, in 1952, an estimated 4000 people died; and recently, in December of 1962, 163 fatalities were reported in London. These unpropitious incidents illustrate the seriousness of air pollution. Likewise, contaminated air is also thought to be a contributing factor to lung cancer.

#### Economic Loss

Economic losses due to air pollution are just as exasperating. This factor alone would warrant attempts to control

the problem. Air pollution can damage building materials, decrease farmer, livestock and dairymen's profits, shorten the life of home furnishings and clothes, and blighten large sections of urban areas.

These facts are undisputed, but it is extremely difficult to establish a dollar value for these losses. Nevertheless, considering all factors, Surgeon General Luther L. Terry has estimated that air pollution costs the people of the United States at least seven billion dollars per year. Industry and government have found that air contamination control is a costly problem, yet they have also recognized that it is even more expensive to ignore.

#### LA Air Pollution

One of the most serious air pollution areas in the United States is Los Angeles, California. A combination of factors, including topography, climate, industrial growth, and an abundance of automobiles, has resulted in an air pollution problem which is the number one public problem. It has resulted in millions of dollars of research and study, and many more millions in contamination control equipment.

Extensive studies in the Los Angeles area have shown that automobile engines are the largest single source of air contamination. Currently more than two and a half million automobiles in Los Angeles county burn over five million gallons of gasoline a day. On a weight basis, approximately seven per cent of the gasoline entering an automobile engine is emitted as an organic pollutant in the exhaust. This exhaust consists mainly of hydrocarbons, oxides of nitrogen, aldehydes, and particulate matter.

United States auto industries have become increasingly aware of the growing problem. For the past ten years they have been pouring millions of dollars

into research. Likewise, car manufacturers have agreed to work in the public interest and exchange information and share patents freely in a cross licensing arrangement. Inventors have submitted more than 100 devices and ideas for evaluation by a special committee of the Automobile Manufacturers Association.

#### The 'Blowby' Breakthrough

At last a successful breakthrough—the blowby—has been developed. This deceptively simple unit is standard equipment on all 1963 cars and trucks. It collects unburned gases, which would otherwise be released into the air as fumes, and sends them back through a tube to the engine, where they are burned. This device reduces automobile air pollution by 25 to 40 per cent, depending on driving conditions, the size of the engine, and its mechanical condition. The remainder of the smog-producing hydrocarbon and carbon monoxide come from the exhaust gas.

#### Positive Crankcase Ventilation

The importance of eliminating blowby gases that leak past the piston rings and collect in the crankcase has been recognized for many years. . . . A breather is installed at the top of the crankcase and an outlet, or road draft tube, at the bottom. A vacuum is thus created at the end of the tube which draws the fumes out of the crankcase into the atmosphere. When the car is moving the system works well, but it is ineffective for city delivery trucks, taxis, and other vehicles operating at slow or idle speeds for extended periods. Positive Crankcase Ventilation, PCV, was developed to prevent excessive sludge formation in these "slow" engines. Since manifold vacuum is high at light load and slow speed, it is used to draw fumes from the crankcase into the intake manifold, where it is mixed with incoming fuel and air, and then passed into the



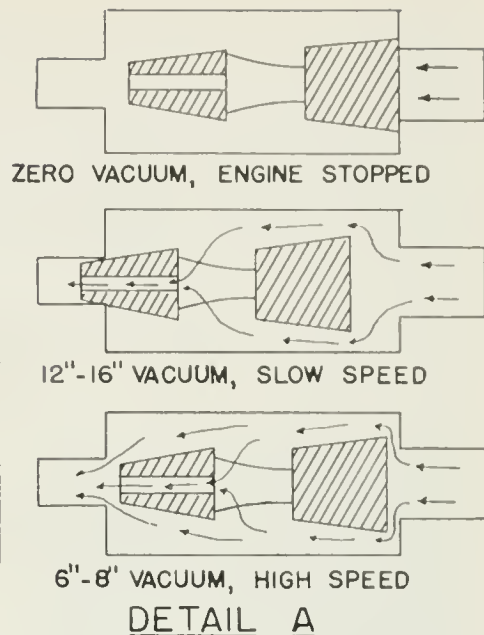
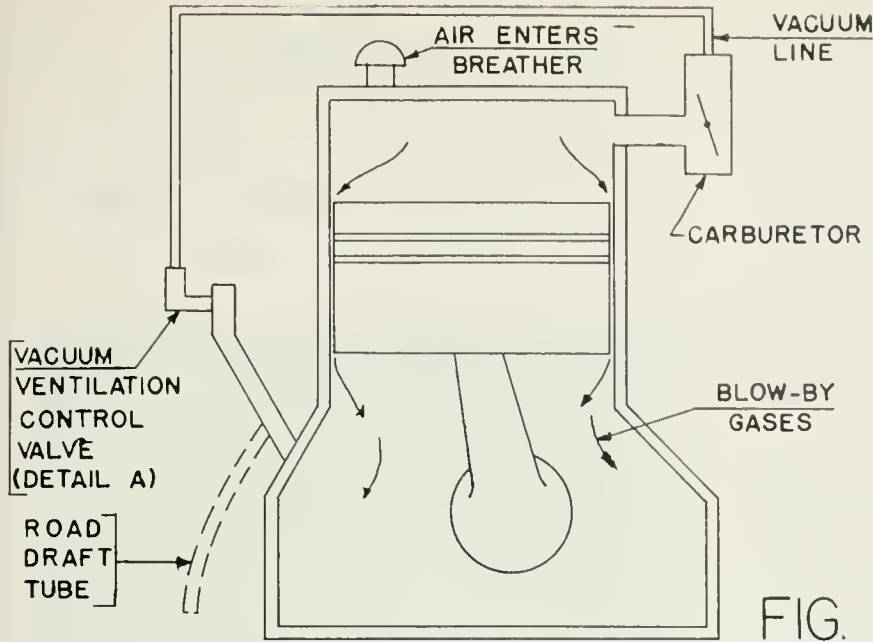

FIG. 1

cylinders to be burned.

General Motors engineers working on an industry wide program to decrease air pollution discovered that PCV also substantially reduces the volume of unburned hydrocarbons released to the atmosphere. Car manufacturers, therefore, agreed to install PCV on all autos manufactured for sale in California, and later decided to include the device on all new automobiles.

The critical mechanism of PCV is a valve the size of a man's thumb. At light load and low speed, manifold vacuum holds the valve closed, thereby restricting the flow of ventilating air and fumes to a suitable volume that can pass through a small orifice in the center of the plunger. (See Fig. 1) As the throttle is opened, manifold vacuum drops and a spring forces the valve from its seat, permitting increased flow from the crankcase to the intake manifold. The valve is necessary because the volume of air entering the manifold at idle must be

limited to maintain a suitable engine fuel to air ratio.

Unfortunately, fumes passing through the valve are contaminated with oil, water, carbon, and unburned particles of fuel—all are ingredients of sludge. After prolonged use the valve either sticks or becomes completely clogged.

When the valve sticks in the open position the idling mixture becomes too lean and the engine vibrates and frequently stalls. If the valve sticks in the closed position, very little ventilating air can pass through the crankcase and internal pressures build up, thus pouring fumes out of the breather cap or pushing oil past seals and gaskets. If the valve becomes completely clogged the engine idles roughly because of a rich mixture, crankcase pressure builds up even higher, and sludge forms rapidly.

Thus it can be seen that PCV is not by any means the perfect solution, but at the current time it is the best device available.

Other research teams are working on devices to help control and reduce the percentage of hydrocarbon and carbon monoxide in automobile exhaust. Three methods which are currently under test are:

- 1) Catalytic Burner
- 2) Flame Afterburner
- 3) Added air into the exhaust manifold.

#### Catalytic Burner

The General Motors catalytic burner meets, under some conditions, the strict requirements of the California Motor Vehicle Pollution Control Board—the board that has prompted manufacturers to help solve the pollution problem. The converter is functionally and structurally satisfactory, but catalyst life doesn't meet the control board's minimum standard, which requires a minimum life of 12,000 miles.

(Continued on Next Page)

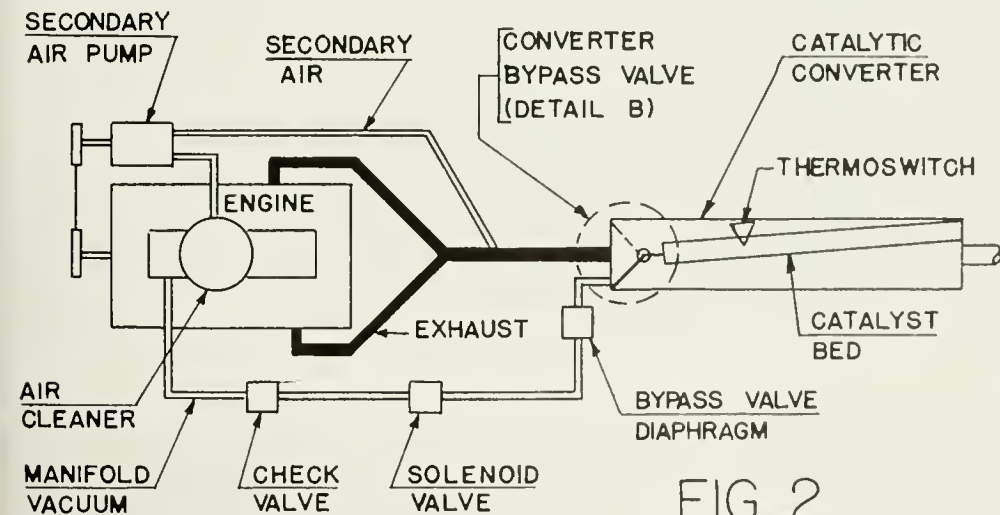
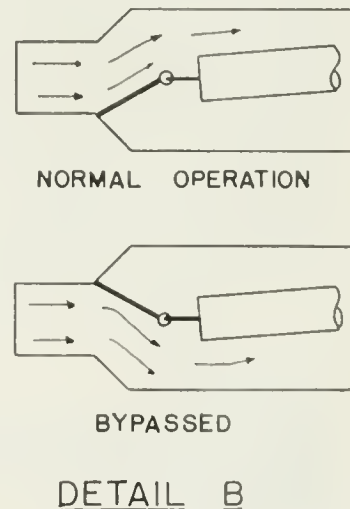

FIG. 2



The converter replaces the conventional muffler in an exhaust system. It is placed as close to the engine as possible for maximum heat transfer to the catalyst during the warm up and constant speed driving.

An air pump, which is belt driven from the engine, takes in air through the carburetor air cleaner and discharges it into the exhaust pipe, far enough upstream of the converter's entrance to provide mixing. This air must be added since exhaust gas seldom contains enough oxygen to burn all the combustibles.

The catalyst bed, formed with a lead-resistant catalyst produced by Oxy-Catalyst, Incorporated, is inclined to the converter shell. This provides better gas velocity distribution throughout the bed and minimizes height.

With severe driving conditions, a malfunctioning carburetor, or a fouled spark plug, increased amounts of fuel and air combine and ignite in the converter, resulting in an excessive amount of heat to the bed. These high temperatures warp the grid and shell, and even some loss of catalytic activity if the high temperature is sustained. This problem is eliminated by a bypass valve at the converter entrance which can direct exhaust either under or through the catalytic bed. A thermostitch with its probe located in the center of the bed senses the catalyst temperature and by means of a solenoid valve actuates the bypass valve.

The catalytic converter still requires more development, especially to extend the life of the catalyst. Its operation has been improved somewhat by injecting extra air into exhaust ports rather than the conventional exhaust pipe.

#### Flame Afterburner

Another device that created early enthusiasm is a flame afterburner. Due to many difficulties however, enthusiasm has waned. Its operation depends upon an auxiliary flame burner in the exhaust system. Numerous design problems have eliminated this device from further development. The problems include:

- 1) Special alloys to withstand the very high temperatures.
- 2) Complicated methods to maintain gas pressure and sustain burning.
- 3) The requirement and expense of additional fuel.

#### Added Exhaust Air

Another seemingly simple device is the addition of air into the exhaust manifold to ignite undesired gases. Ford Motor Company is leading this development. They are utilizing two refinements to improve its results—a burning box to extend the time for hydrocarbons to combine, and added insulation to decrease the warmup time of the box. This method is not entirely satisfactory, and it does not work on compact cars. . . . Mass production is a long way off.

The satisfactory elimination of automobile air pollution has thus far thwarted development engineers, who are working on a near crash program. Even after the expense of thousands of working hours and many millions of dollars, the problem is not entirely solved. All that can be shown is a simple blowby device, and various other semi-satisfactory units.

Still, what the future holds is unknown. The problem of air pollution by automobiles must be solved, or else the serious air contamination problem will become even more widespread. Only through the continued efforts of engineers and scientists and the expense of millions of dollars will the solution be found. ♦♦♦

## New FILM-THIN Copper-clad Laminates for space-saver or multi- layer printed circuits



Synthane copper-clad laminates are now being produced with a base laminate of only .0035" and up—with 1 or 2 oz. cladding available on one or both sides. A pre-impregnated glass cloth with epoxy resin filler is also available for bonding multi-layer circuits. These new materials are produced under clean room conditions. Property values are comparable to military specs for the same materials in standard thicknesses. Write for folder of Synthane metal-clad laminates.

# SYNTHANE

CORPORATION **S** OAKS, PENNA.

Glendale 2-2211 (Area Code 215) TWX 215-666-0589  
Synthane-Pacific, 518 W. Garfield Ave., Glendale 4, Calif. TWX GLDL 4417U

Synthane Corporation, 13 River Rd., Oaks, Pa.  
Gentlemen:  
Please send me Synthane metal-clad laminates folder.

Name \_\_\_\_\_

Address \_\_\_\_\_

City \_\_\_\_\_ Zone \_\_\_\_\_ State \_\_\_\_\_



*Opportunities are better than  
ever at Bethlehem Steel!*

## We will not offer you just a job

(but if you're interested in a *career*, talk it over with us)

When we invite a man to join the Bethlehem Loop Course, we are not offering him a "job." We are inviting him to begin a *career*. And, for that reason, we train him—thoroughly—before he begins his first work assignment.



### The Bethlehem Loop Course

Since its beginning some forty years ago, the Loop Course has trained about 2,000 men who now occupy responsible positions at all levels of supervision and management. The name comes from the fact that members of the course make an observational circuit (or "loop") of a steel plant during their basic training program.

New loopers report to our general headquarters in Bethlehem, Pa., early in July. They attend a basic

course lasting five weeks. It includes talks and discussions by top Company officials, educational films, and daily plant visits. The Loop Course is *not* a probationary period. After completing the course, every looper is assigned to a Bethlehem activity where he receives additional specialized instruction before beginning actual on-the-job training.

### Plenty of Opportunity

Because of the size and diversity of its operations, Bethlehem offers unlimited opportunities to "get ahead." It's one of the nation's largest industrial corporations, with about 130,000 employees, engaged in raw materials mining and processing, basic steelmaking, manufacturing of finished products, structural steel fabricating and erecting, shipbuilding, and ship repair. We operate steelmaking plants in the East and on the



Pacific Coast; shipyards on the Atlantic, Gulf, and Pacific Coasts; manufacturing units and fabricating works in twelve states; and sales offices in most leading cities. Our new research laboratories, in Bethlehem, Pa., are unexcelled by any industry.

### Read Our Booklet

The eligibility requirements of the Loop Course, as well as how it operates, are more fully covered in our booklet, "Careers with Bethlehem Steel and the Loop Course." Copies are available in most college placement offices, or may be obtained by writing to Manager of Personnel, Bethlehem Steel Company, Bethlehem, Pa.

*An equal opportunity employer*



# BETHLEHEM STEEL



In aircraft parts, as in men, excessive stress accelerates the aging process. And stress aging per hour varies for each aircraft. Yet the present way of determining servicing schedules is based primarily on hours flown. □ Now Douglas researchers have developed a device which, when installed on an aircraft, provides a more positive method of determining check-up times for aircraft parts. □ Called a "Service Meter," and weighing less than 1½ pounds, the Douglas unit computes the accelerations encountered by its aircraft in relation both to number and severity. It allows servicing

## AEROSPACE GERIATRICS

...A STIMULATING AREA FOR CREATIVE ENGINEERS

to be performed on the basis of the true work age of parts, and will be an important aid to maintenance procedures that keep aircraft young. □ Research like the foregoing has helped build the Douglas reputation for producing the world's most reliable aircraft.

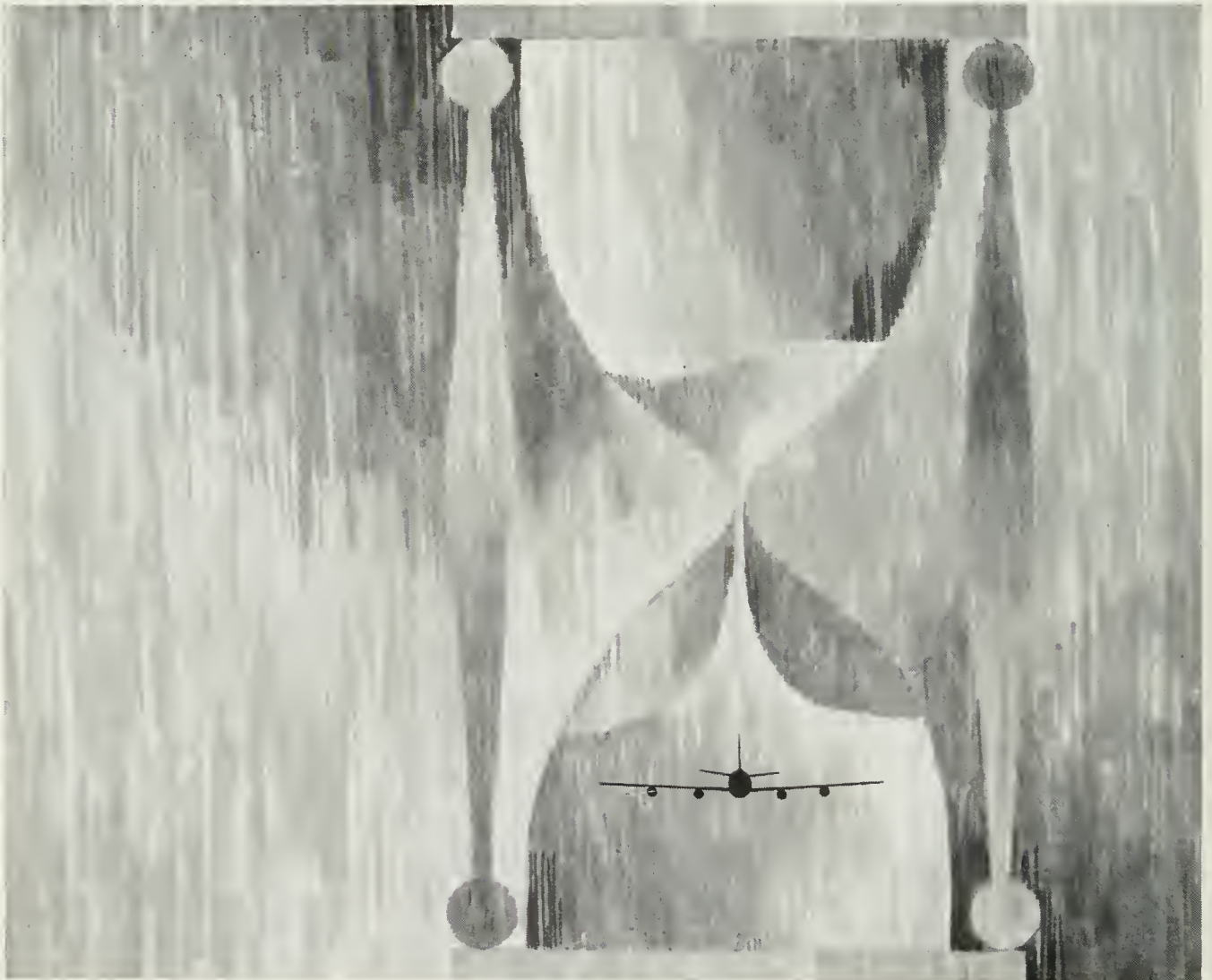

If you are seeking a stimulating career in the thick of the most vital programs of today and tomorrow, we invite you to contact us. Write to Mr. S. A. Amestoy, Douglas Aircraft Company, 3000 Ocean Park Blvd., Santa Monica, California, **DOUGLAS** Box 600-M. An equal opportunity employer.

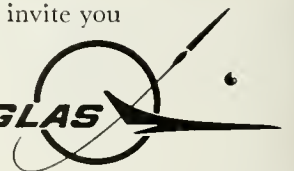



*Miss  
Kathee  
Hrudka*

A Pi Phi with a purpose



Are you low and depressed? Or perhaps you are a struggling, underprivileged, underdeveloped engineer caught in the grasp of this scholarly jungle. If so, meet 18 year old Miss Kathee Hrudka . . . the solution to every engineer's problem.

Upon graduation in LAS she plans to go to Africa as a social worker for the Peace Corps; however, any engineer worthy of his slide rule could surely convince her to rectify his own domestic enigma.

Many convincing routes could be devised, but as a start we suggest you join the Ochesis Dance Concert as a dancer, Campus Chest, and Star Course . . . her campus activities. Likewise, you should learn to water and snow ski, dance, and write music as well as play the piano . . . Don't worry about "the cabin on the lake" she can provide that—provided you are convincing enough!



*Assignment: design a suspension  
that "paves" its own way!*

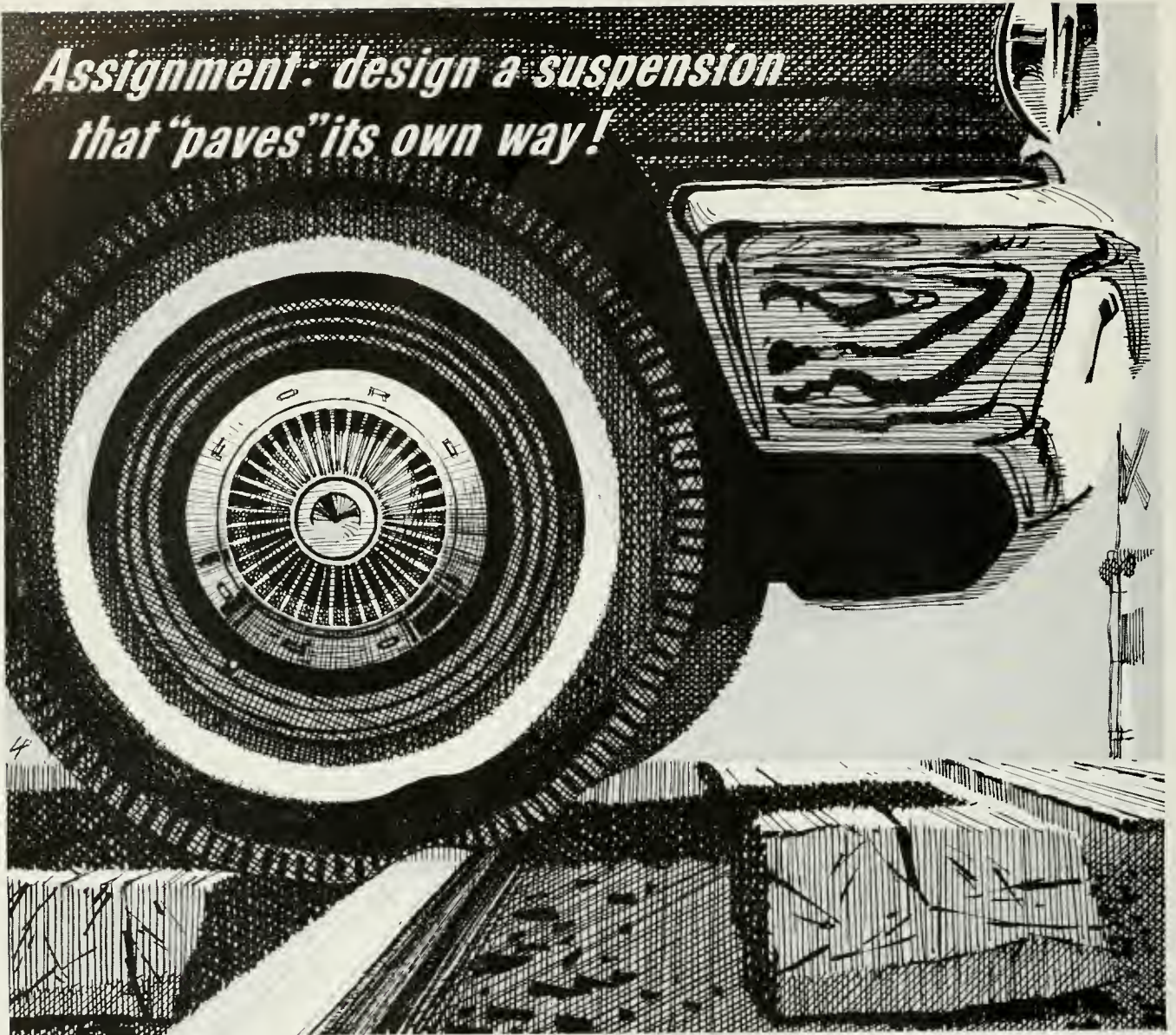

**Result: "Cushion Recoil" provides a  
dramatically smoother ride  
in 1963 Ford-built cars**

The challenge given Ford engineers was to design suspensions that would permit wheels virtually to roll with the punches—not only in a vertical plane but fore-and-aft as well. Conventional suspension systems provide only a partial solution to road shocks by limiting wheel recoil to an up-and-down motion.

The solution? Exclusive Cushion Recoil suspension design in all Ford-built cars for '63! Cushion Recoil, with cushioning action in a fore-and-aft plane as well as vertical, smoothes the jars and jolts of rough roads, adds to your comfort, safety, and driving pleasure. Even the thump of freeway tar strips is reduced, and on deeply rutted roads you experience better control of the car. Furthermore, your Ford-built car is spared the wear and tear of road-induced vibration.

Another assignment completed—one more example of engineering excellence at Ford and new ideas for the American Road.



**SOAKS UP ROAD SHOCK.** Exclusive Ford Motor Company Cushion Recoil action moves back as well as up for a smoother ride.



MOTOR COMPANY  
The American Road, Dearborn, Michigan

**WHERE ENGINEERING LEADERSHIP  
BRINGS YOU BETTER-BUILT CARS**





*Garrett space radiator  
for manned and unmanned  
vehicles*

## Advanced solution to a heat transfer problem

Complex, long duration satellites and manned spacecraft must get rid of large amounts of internally produced heat. Through unique fabrication techniques and know-how with exotic materials, Garrett-AiResearch is building active (fluid cycle) radiator systems for cooling space vehicles.

Garrett is also developing heat transfer systems for applications from cryogenic temperatures to 2000°F, using heat transfer fluids such as Coolanol 139, Freon 21, FC-75, mercury and alkali liquid metals including potassium, rubidium and cesium.

This critical development work is supported by more than a quarter century of Garrett heat transfer experience. It is one more example of Garrett's proved capability in the design and production of vital systems and their components for spacecraft, missile, aircraft, electronic, nuclear and industrial applications.

For further information about the many interesting project areas and career opportunities at The Garrett Corporation, write to Mr. G. D. Bradley in Los Angeles. Garrett is an equal opportunity employer.



THE GARRETT CORPORATION • AiResearch Manufacturing Divisions • Los Angeles 9, California • Phoenix, Arizona • other divisions and subsidiaries: Airsupply-Aero Engineering • AiResearch Aviation Service • Garrett Supply • Air Cruisers • AiResearch Industrial • Garrett Manufacturing Limited • Garrett International S. A. • Garrett (Japan) Limited

# TECHNOQUIPS

A story going the rounds concerns three pregnant squaws who slept on animal skins—one, on an elk skin; another, on a buffalo skin; the third on a hippopotamus skin. The first squaw had a son; the second, a son; and the third, twin boys.

Which proves: the squaw of the hippopotamus is equal to the sons of the squaws on the other two hides.

\* \* \*

Very proud parent: "Edith is taking a correspondence course in trigonometry. Speak a few words in trigonometry dear."

\* \* \*

M.E.: "Going around a lot with women keeps you young."

2nd M.E.: "Why's that?"

M.E.: "I started going around with women when I was a freshman two years ago, and I'm still a freshman."

\* \* \*

An I.E. was discovered by his wife one night standing over his baby's crib. Silently she watched him. As he stood looking down at the sleeping infant, she saw in his face a mixture of emotions that she had never seen before—rapture, admiration, doubt, despair, ecstasy, incredulity. Touched and wondrous alike at his unusual parental attitude and the conflicting emotions, his wife with her eyes glistening, arose and slipped her arm around him. "A penny for your thoughts," she said in a tremulous voice.

He blurted them out: "For the life of me, I don't see how anybody can make a crib like that for \$3.49!"

\* \* \*

Papa sparrow returned to his nest and proudly announced that he had made a deposit on a new Buick.

\* \* \*

A professor wanted to call a friend in Gopeck. The operator had trouble understanding the name of the town and asked the professor to spell it. "The name is Gopeck, operator," said the professor; "G for gnome, O for one, P for phyclic, E for eye, C for chan-delier, K for knight."

\* \* \*

Did you hear about the absent-minded professor who sent his wife to the bank and kissed his money goodbye?

The day after finals, a Chem.E. walked into a psychiatrist's office, tore open a cigarette, and stuffed the tobacco up his nose.

"I see that you need some help," remarked the startled doctor.

"Yeah," agreed the student. "Do you have a match?"

\* \* \*

A motorist after being bogged down in a muddy road paid a passing farmer ten dollars to pull him out with a team. After he was on the road again, he remarked to the farmer, "I should think that at that price you'd be pulling people out of this stuff day and night."

"Nope," drawled the farmer, "at night's when I tote the water for the holes."

\* \* \*

"It isn't the amount of money that a fellow's father has that counts here at college."

"No, it's the amount of father's money the son has."

\* \* \*

Last night I held a little hand,  
So dainty and so sweet.  
I thought my heart would surely break,  
So wildly did it beat.  
No other hand in all this world,  
Can greater solace bring,  
Than that sweet hand I held last night,  
Four aces and a king.

\* \* \*

Prof: "Well, is the theory clear to you now?"

Student: "Yeah, just as though it had been translated into Hindustani by Gertrude Stein and read to me by a tobacco auctioneer."

\* \* \*

During a grouse hunt one sportsman was shooting at a clump of trees near a stone wall. Suddenly an angry face popped over the top of the wall. "Curse you, you almost hit my wife!"

"Did I?" cried the man, "I'm terribly sorry—have a shot at mine over there."

\* \* \*

"What a day. I lost my job, I lost my billfold, my wife ran away with the electric light man, the Cards lost to Brooklyn. It's unbelievable—leading by three in the eighth and they lost to Brooklyn."

The orator had held forth for a long time his talk punctuated only by an occasional pause for a drink of water.

A man near the front commented, in a loud whisper, "First time I've ever seen a wind mill run by water."

\* \* \*

The scene is a train compartment in Rumania. The characters: A Russian officer, a Rumanian, an old lady, and an attractive girl.

The train enters a tunnel. The passengers hear first a kiss, then a vigorous slap.

The old lady thinks: "What a good girl she is, such good manners, such fine moral character!"

The girl thinks: "Isn't it odd that the Russian tried to kiss the old lady and not me?"

The Russian thinks: "That Rumanian is a smart fellow: he steals a kiss and I get slapped."

The Rumanian thinks: "Am I a smart fellow! I kiss the back of my hand, hit a Russian officer, and get away with it."

\* \* \*

A lonely chick taking a look around the electric incubator of unhatched eggs—"Well, it looks as if I'll be an only child. Mother's blown a fuse."

\* \* \*

There is only one engineer who ever got rich. He recently died in Colorado and left a fortune of \$50,000 which he amassed through unceasing toil, superhuman perseverance, remarkable ingenuity, and the death of an uncle who left him \$49,000.

\* \* \*

Our unabashed Dictionary defines *bachelor* as a rolling stone who gathers no boss.

\* \* \*

Mother: "Now, Junior, be a good boy and say 'Ah-h-h' so the doctor can get his finger out of your mouth."

\* \* \*

Captain: "Why didn't you salute me yesterday?"

ROTC Recruit: "I didn't see you, sir."

Captain: "Oh, that's all right then. I was afraid you were mad at me."

\* \* \*

And then there was the butcher who backed into a meat grinder and got a little behind in his orders.

---

**Answer to last month's Brain Buster number 3.**

White and Mrs. Black played against Black and Mrs. Pink at one table. At the other table Green and Mrs. White opposed Pink and Mrs. Green.

---



## This kind of engineer designs jobs instead of things



Once upon a time there was a creature known to jokesmiths as "the efficiency expert." When he wasn't being laughed at, he was being hated. Kodak felt sorry for the poor guy and hoped that in time he could be developed into an honored, weight-pulling professional. That was long ago.

We were then and are much more today a very highly diversified manufacturer. We need mechanical, electrical, chemical, electronic, optical, etc., etc. engineers to design equipment and processes and products for our many kinds of plants, and make it all work. But all the inanimate objects they mastermind eventually have to link up with *people* in some fashion or other—the people who work in the plants, the people who manage the plants, and the people who buy the products. That's why we need "industrial engineers."

A Kodak industrial engineer learns mathematical model-building and Monte Carlo computer techniques. He uses the photographic techniques that we urge upon other manufacturing companies. He collaborates with medicos in physiological measurements, with architects, with sales executives, with manufacturing executives, with his boss (G. H. Gustat, behind the desk above, one of the Fellows of the American Institute of Industrial Engineers). He starts fast. Don Wagner (M.S.I.E., Northwestern '61) had 4 dissimilar projects going the day the above picture was sneaked. He is not atypical. *Want to be one?*

**Kodak**

**EASTMAN KODAK COMPANY** • Business & Technical Personnel Department  
ROCHESTER 4, N.Y. • An equal-opportunity employer.

# How Industry Tempers Theory with Practice to Get Good Design

## An Interview with G.E.'s F. K. McCune, Vice President, Engineering



As Vice President—Engineering, Francis K. McCune is charged with ensuring the effective development, use and direction of General Electric's engineering talent. Mr. McCune holds a degree in electrical engineering and began his career with the Company as a student engineer.

For complete information on opportunities for engineers at General Electric, write to: Personalized Career Planning, General Electric Company, Section 699-07, Schenectady 5, N. Y.

**Q. Mr. McCune, how do you define engineering design?**

A. First let's look at what engineering really is. The National Society of Professional Engineers calls it "the creation of technical things and services useful to man." I would paraphrase that to add an industry emphasis: engineering is linking an *ability to do* with specific customer *needs and wants*. The link is an engineering design of a useful product or service.

**Q. In the light of this definition, how can the young engineer prepare himself for industry?**

A. In college he should absorb as much theory as possible and begin to develop certain attitudes that will help him later in his profession. The raw material for a design, information, flows from three general funds: Scientific Knowledge of Nature; Engineering Technology; and what I call simply Other Relevant Information. Academic training places heavy emphasis on the first two areas, as it should. Engineers in industry draw heavily on theorems, codified information, and significant recorded experience basic to engineering disciplines taught in college. The undergraduate must become knowledgeable in these areas and skilled in the ways of using this information, because he will have little time to learn this after graduation. He also must develop a responsive attitude toward the third fund.

**Q. As you say, we learn theory in college, but where do we get the "Other Relevant Information"—the third fund you mentioned?**

A. This knowledge is obtained for the most part by actually doing engineering work. This is information that *must* be applied to a design to make sure that it not only works, but that it also meets the needs and wants that prompted its consideration in the first place. For example, we can design refrigerators, turbines, computers, or missile guidance systems using only information from the first two funds of knowledge—heat flow, vibration, electronic theory, etc.—and they will work! But what about cost, reliability, appearance, size—will the prospective customer buy them? The answers to these important design questions are to be found in the third fund; for example the information to determine optimum temperature ranges, to provide the features that appeal to users, or to select the best manufacturing processes. In college you can precondition yourself to seek and accept this sort of information, but only experience in industry can give you specific knowledge applicable to a given product.

**Q. Could you suggest other helpful attitudes we might develop?**

A. Remember, industry exists to serve the needs and wants of the market place, and the reasons for doing things a certain way arise from the whole spread of conditions which a given design has to satisfy. Learn how to enter into good working relationships with people. Much of the Other Relevant Information can be picked up only from others. Also train yourself to be alert and open-minded about your professional interests. In industry you'll be expected to learn quickly, keep abreast in your field, and to grow from assignment to assignment. Industry will give you the opportunity. Your inherent abilities and attitudes will largely decide your progress.

*Progress Is Our Most Important Product*

GENERAL  ELECTRIC









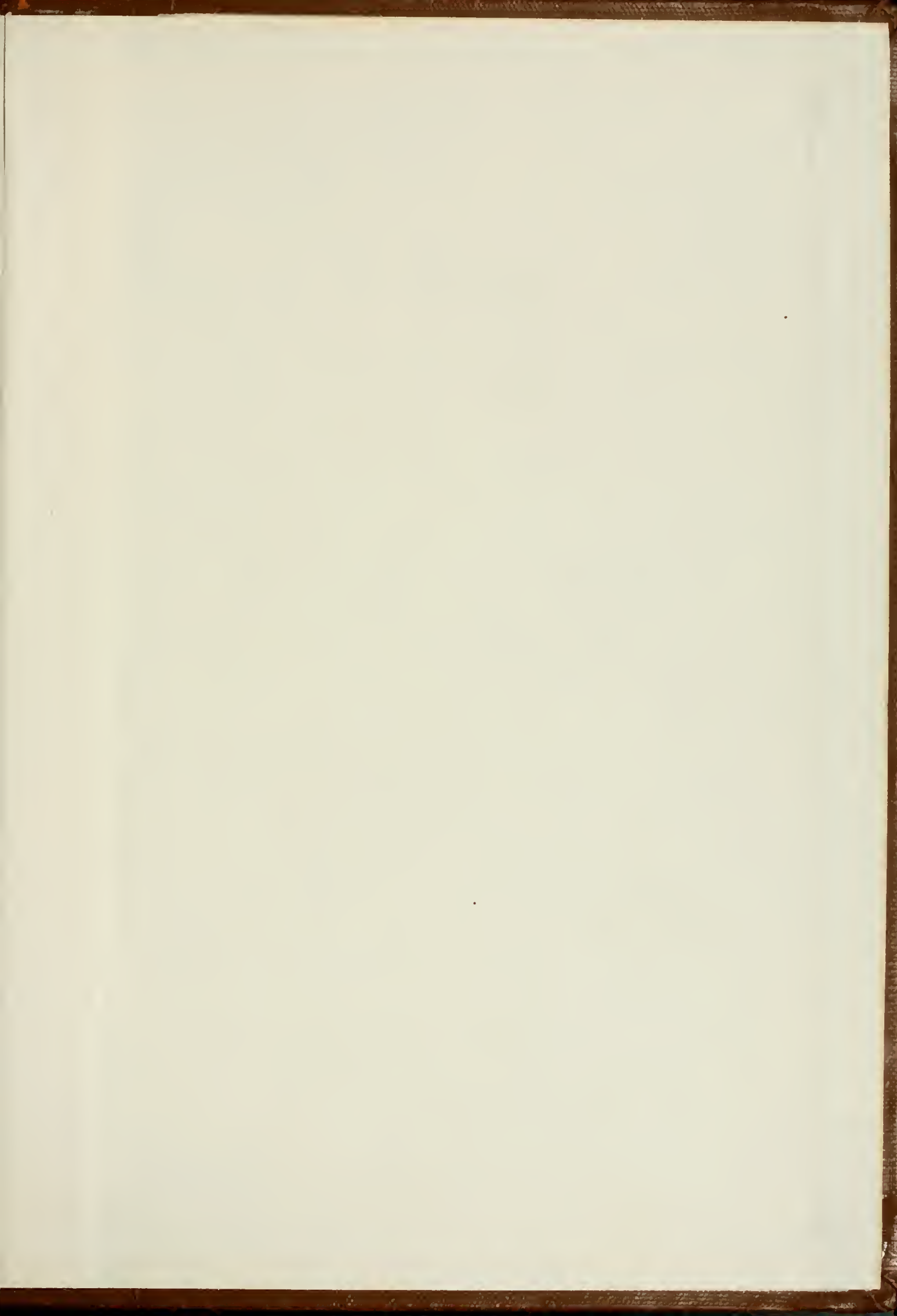

UNIVERSITY OF ILLINOIS-URBANA



3 0112 061160336