

UC-NRLF



5B 24 679



EX LIBRIS



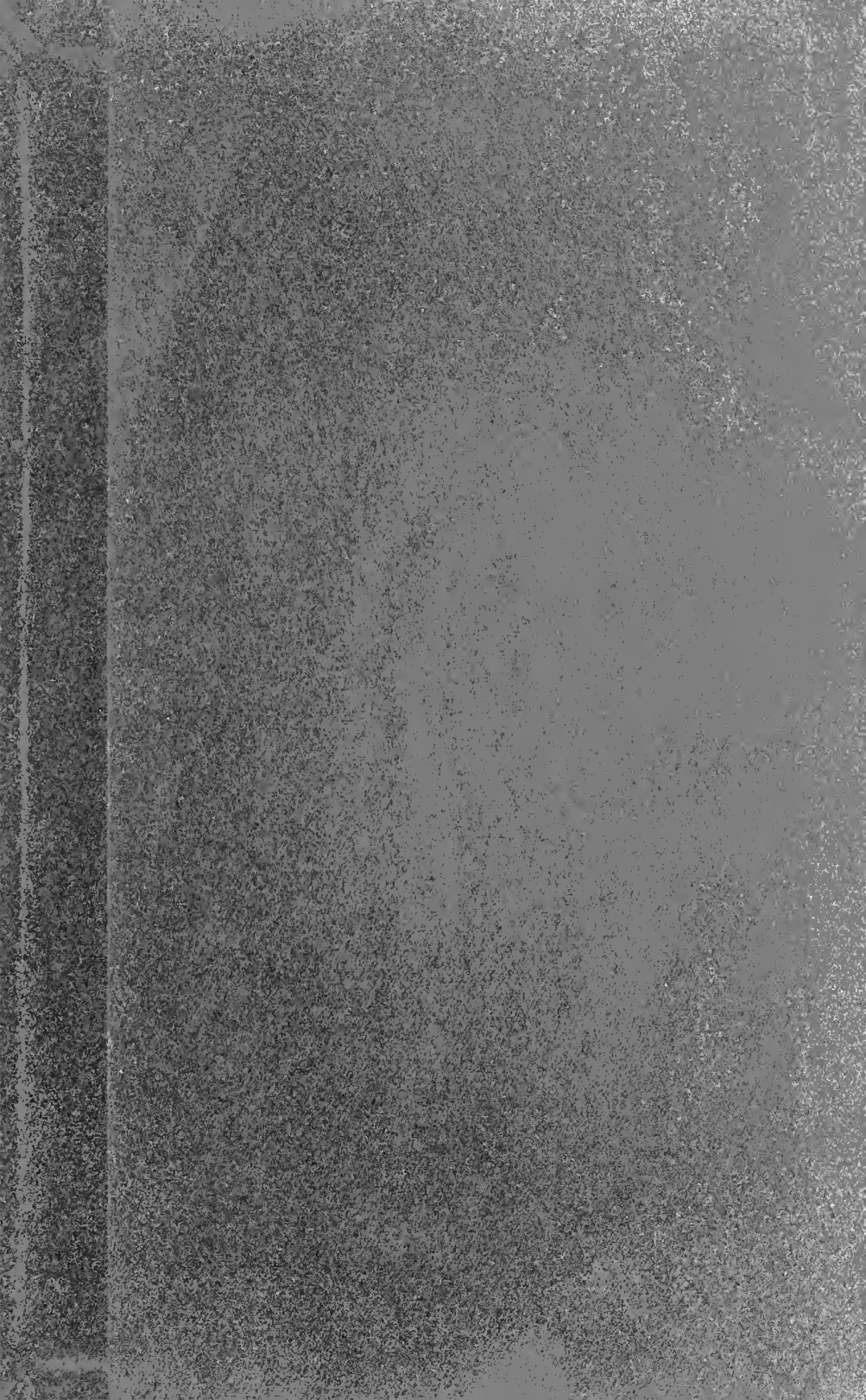

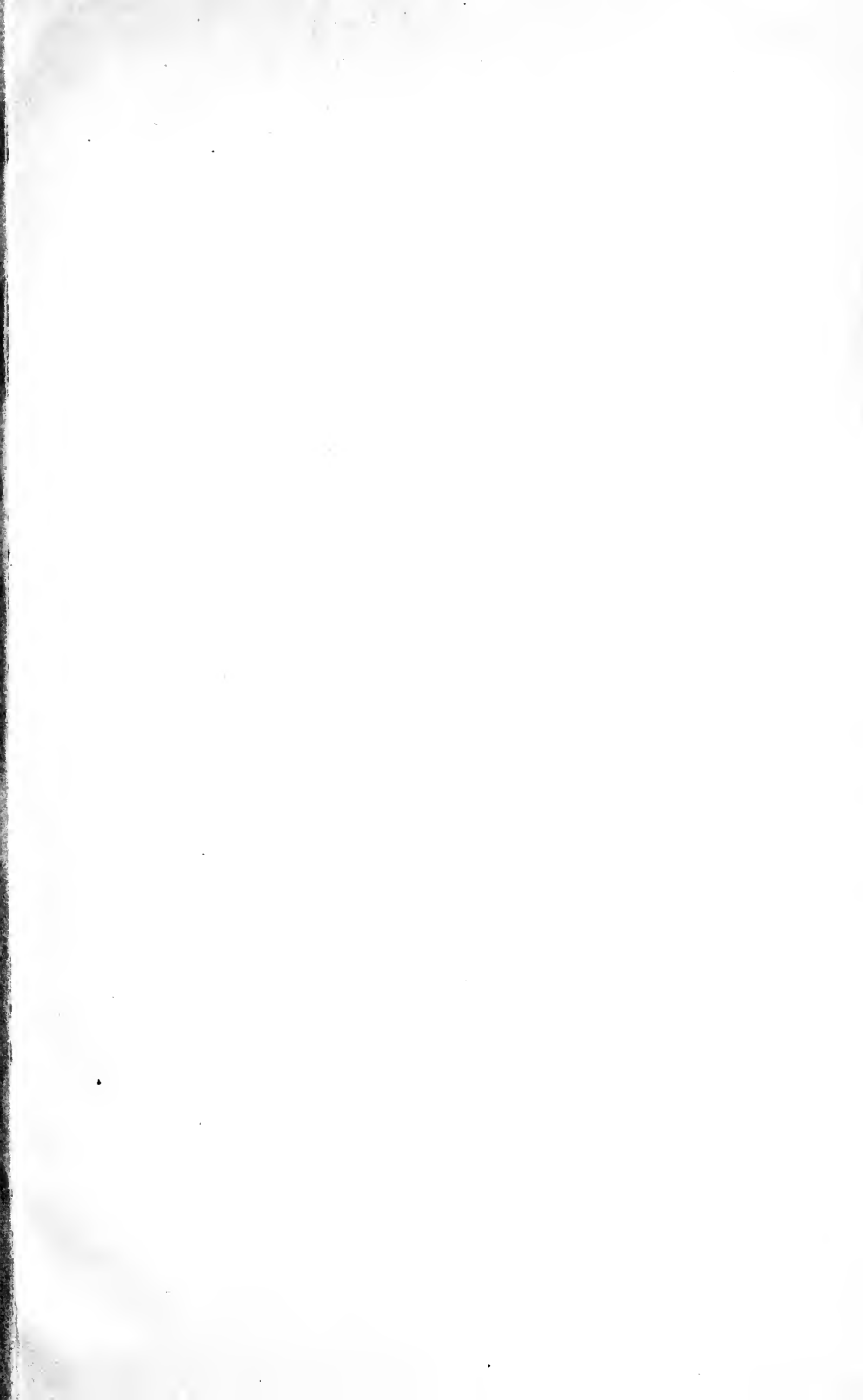

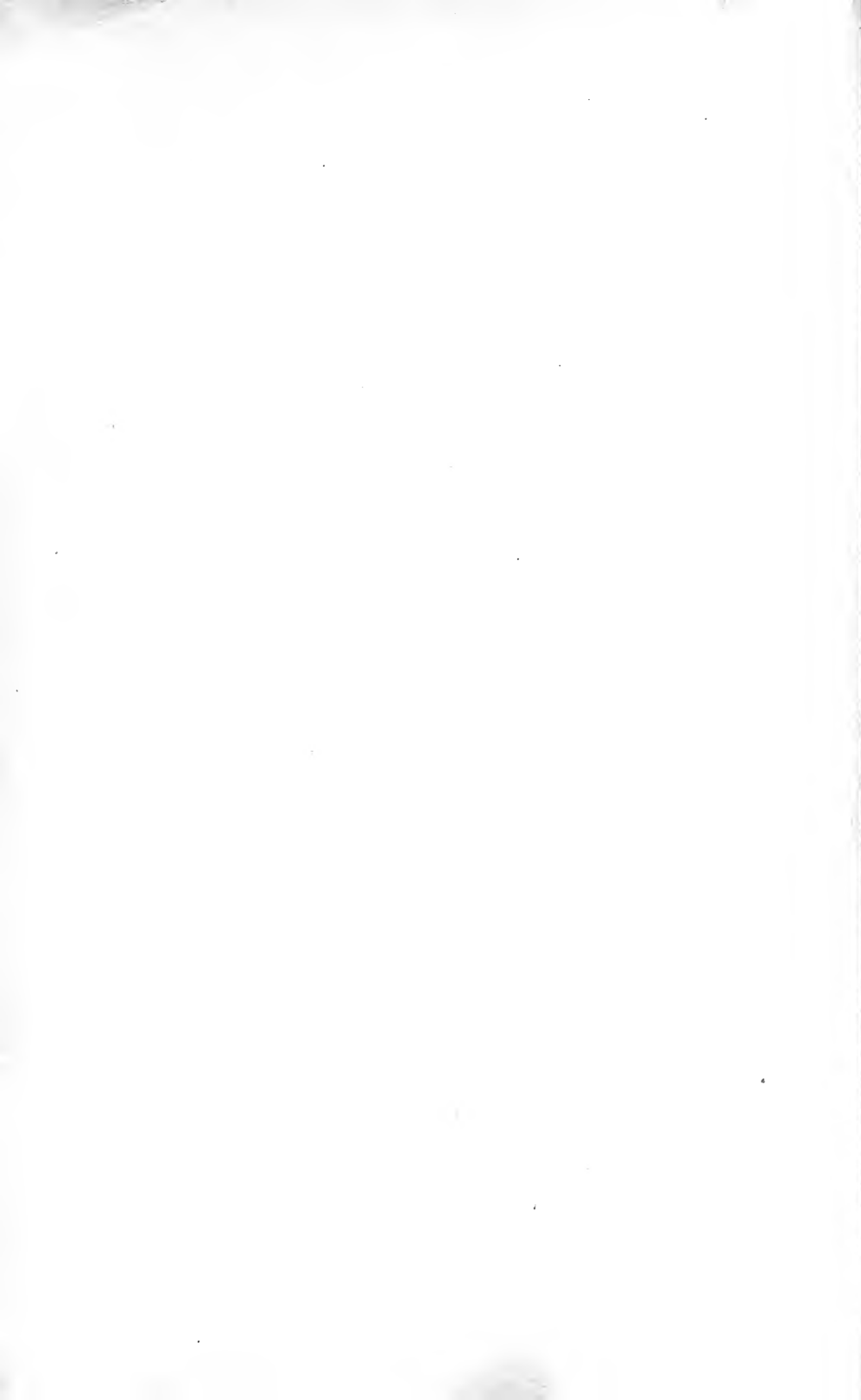

THE THEORY OF MEASUREMENTS

McGraw-Hill Book Company

Publishers of Books for

Electrical World	The Engineering and Mining Journal
Engineering Record	Engineering News
Railway Age Gazette	American Machinist
Signal Engineer	American Engineer
Electric Railway Journal	Coal Age
Metallurgical and Chemical Engineering	Power

THE THEORY OF
MEASUREMENTS

BY

A. DE FOREST PALMER, PH.D.

Associate Professor of Physics in Brown University.

LIBRARY OF
CALIFORNIA

MCGRAW-HILL BOOK COMPANY

239 WEST 39TH STREET, NEW YORK

6 BOUVERIE STREET, LONDON, E.C.

1912

QC
39
P3

COPYRIGHT, 1912,
BY THE
MCGRAW-HILL BOOK COMPANY

TO THE
LIBRARY OF

Stanhope Press
F. H. GILSON COMPANY
BOSTON, U.S.A.

PREFACE.

THE function of laboratory instruction in physics is twofold. Elementary courses are intended to develop the power of discriminating observation and to put the student in personal contact with the phenomena and general principles discussed in textbooks and lecture demonstrations. The apparatus provided should be of the simplest possible nature, the experiments assigned should be for the most part qualitative or only roughly quantitative, and emphasis should be placed on the principles illustrated rather than on the accuracy of the necessary measurements. On the other hand, laboratory courses designed for more mature students, who are supposed to have a working knowledge of fundamental principles, are intended to give instruction in the theory and practice of the methods of precise measurement that underlie all effective research and supply the data on which practical engineering enterprises are based. They should also develop the power of logical argument and expression, and lead the student to draw rational conclusions from his observations. The instruments provided should be of standard design and efficiency in order that the student may gain practice in making adjustments and observations under as nearly as may be the same conditions that prevail in original investigation.

Measurements are of little value in either research or engineering applications unless the precision with which they represent the measured magnitude is definitely known. Consequently, the student should be taught to plan and execute proposed measurements within definitely prescribed limits and to determine the accuracy of the results actually attained. Since the treatment of these matters in available laboratory manuals is fragmentary and often very inadequate if not misleading, the author some years ago undertook to impart the necessary instruction, in the form of lectures, to a class of junior engineering students. Subsequently, textbooks on the Theory of Errors and the Method of Least Squares were adopted but most of the applications to actual practice were still given by lecture. The present treatise is the result of the experi-

ence gained with a number of succeeding classes. It has been prepared primarily to meet the needs of students in engineering and advanced physics who have a working knowledge of the differential and integral calculus. It is not intended to supersede but to supplement the manuals and instruction sheets usually employed in physical laboratories. Consequently, particular instruments and methods of measurement have been described only in so far as they serve to illustrate the principles under discussion.

The usefulness of such a treatise was suggested by the marked tendency of laboratory students to carry out prescribed work in a purely automatic manner with slight regard for the significance or the precision of their measurements. Consequently, an endeavor has been made to develop the general theory of measurements and the errors to which they are subject in a form so clear and concise that it can be comprehended and applied by the average student with the prescribed previous training. To this end, numerical examples have been introduced and completely worked out whenever this course seemed likely to aid the student in obtaining a thorough grasp of the principles they illustrate. On the other hand, inherent difficulties have not been evaded and it is not expected, or even desired, that the student will be able to master the subject without vigorous mental effort.

The first seven chapters deal with the general principles that underlie all measurements, with the nature and distribution of the errors to which they are subject, and with the methods by which the most probable result is derived from a series of discordant measurements. The various types of measurement met with in practice are classified, and general methods of dealing with each of them are briefly discussed. Constant errors and mistakes are treated at some length, and then the unavoidable accidental errors of observation are explicitly defined. The residuals corresponding to actual measurements are shown to approach the true accidental errors as limits when the number of observations is indefinitely increased and their normal distribution in regard to sign and magnitude is explained and illustrated. After a preliminary notion of its significance has been thus imparted, the law of accidental errors is stated empirically in a form that gives explicit representation to all of the factors involved. It is then proved to be in conformity with the axioms of accidental errors, the principle of the arithmetical mean, and the results of experience. The various characteristic

errors that are commonly used as a measure of the accidental errors of given series of measurements are clearly defined and their significance is very carefully explained in order that they may be used intelligently. Practical methods for computing them are developed and illustrated by numerical examples.

Chapters eight to twelve inclusive are devoted to a general discussion of the precision of measurements based on the principles established in the preceding chapters. The criteria of accidental errors and suitable methods for dealing with constant and systematic errors are developed in detail. The precision measure, of the result computed from given observations, is defined and its significance is explained with the aid of numerical illustrations. The proper basis for the criticism of reported measurements and the selection of suitable numerical values from tables of physical constants or other published data is outlined; and the importance of a careful estimate of the precision of the data adopted in engineering and scientific practice is emphasized. The applications of the theory of errors to the determination of suitable methods for the execution of proposed measurements are discussed at some length and illustrated.

In chapter thirteen, the relation between measurement and research is pointed out and the general methods of physical research are outlined. Graphical methods of reduction and representation are explained and some applications of the method of least squares are developed. The importance of timely and adequate publication, or other report, of completed investigations is emphasized and some suggestions relative to the form of such reports are given.

Throughout the book, particular attention is paid to methods of computation and to the proper use of significant figures. For the convenience of the student, a number of useful tables are brought together at the end of the volume.

A. DE FOREST PALMER.

BROWN UNIVERSITY,
July, 1912.

CONTENTS.

	PAGE
PREFACE.....	v
CHAPTER I.	
GENERAL PRINCIPLES.....	1
Introduction — Measurement and Units — Fundamental and Derived Units — Dimensions of Units — Systems of Units in General Use — Transformation of Units.	
CHAPTER II.	
MEASUREMENTS.....	11
Direct Measurements — Indirect Measurements — Classification of Indirect Measurements — Determination of Functional Relations — Adjustment, Setting, and Observation of Instruments — Record of Observations — Independent, Dependent, and Conditioned Measurements — Errors and the Precision of Measurements — Use of Significant Figures — Adjustment of Measurements — Discussion of Instruments and Methods.	
CHAPTER III.	
CLASSIFICATION OF ERRORS.....	23
Constant Errors — Personal Errors — Mistakes — Accidental Errors — Residuals — Principles of Probability.	
CHAPTER IV.	
THE LAW OF ACCIDENTAL ERRORS.....	29
Fundamental Propositions — Distribution of Residuals — Probability of Residuals — The Unit Error — The Probability Curve — Systems of Errors — The Probability Function — The Precision Constant — Discussion of the Probability Function — The Probability Integral — Comparison of Theory and Experience — The Arithmetical Mean.	
CHAPTER V.	
CHARACTERISTIC ERRORS.....	44
The Average Error — The Mean Error — The Probable Error — Relations between the Characteristic Errors — Characteristic Errors of the Arithmetical Mean — Practical Computation of Characteristic Errors — Numerical Example — Rules for the Use of Significant Figures.	
CHAPTER VI.	
MEASUREMENTS OF UNEQUAL PRECISION.....	61
Weights of Measurements — The General Mean — Probable Error of the General Mean — Numerical Example.	

CHAPTER VII.

THE METHOD OF LEAST SQUARES.....	PAGE 72
Fundamental Principles — Observation Equations — Normal Equations — Solution with Two Independent Variables — Adjustment of the Angles about a Point — Computation Checks — Gauss's Method of Solution — Numerical Illustration of Gauss's Method — Conditioned Quantities.	

CHAPTER VIII.

PROPAGATION OF ERRORS.....	95
Derived Quantities — Errors of the Function $X_1 \pm X_2 \pm X_3 \pm \dots \pm X_q$ — Errors of the Function $\alpha_1 X_1 \pm \alpha_2 X_2 \pm \alpha_3 X_3 \pm \dots \pm \alpha_q X_q$ — Errors of the Function $F(X_1, X_2, \dots, X_q)$ — Example Introducing the Fractional Error — Fractional Error of the Function $\alpha X_1^{\pm n_1} \times X_2^{\pm n_2} \times \dots \times X_q^{\pm n_q}$.	

CHAPTER IX.

ERRORS OF ADJUSTED MEASUREMENTS.....	105
Weights of Adjusted Measurements — Probable Error of a Single Observation — Application to Problems Involving Two Unknowns — Application to Problems Involving Three Unknowns.	

CHAPTER X.

DISCUSSION OF COMPLETED OBSERVATIONS.....	117
Removal of Constant Errors — Criteria of Accidental Errors — Probability of Large Residuals — Chauvenet's Criterion — Precision of Direct Measurements — Precision of Derived Measurements — Numerical Example.	

CHAPTER XI.

DISCUSSION OF PROPOSED MEASUREMENTS.....	144
Preliminary Considerations — The General Problem — The Primary Condition — The Principle of Equal Effects — Adjusted Effects — Negligible Effects — Treatment of Special Functions — Numerical Example.	

CHAPTER XII.

BEST MAGNITUDES FOR COMPONENTS.....	165
Statement of the Problem — General Solutions — Special Cases — Practical Examples — Sensitiveness of Methods and Instruments.	

CHAPTER XIII.

RESEARCH.....	192
Fundamental Principles — General Methods of Physical Research — Graphical Methods of Reduction — Application of the Method of Least Squares — Publication.	

TABLES.....	212
-------------	-----

INDEX.....	245
------------	-----

LIST OF TABLES.

	PAGE
I. DIMENSIONS OF UNITS.....	212
II. CONVERSION FACTORS.....	213
III. TRIGONOMETRICAL RELATIONS.....	215
IV. SERIES.....	217
V. DERIVATIVES.....	219
VI. SOLUTION OF EQUATIONS.....	220
VII. APPROXIMATE FORMULÆ.....	221
VIII. NUMERICAL CONSTANTS.....	222
IX. EXPONENTIAL FUNCTIONS e^x AND e^{-x}	223
X. EXPONENTIAL FUNCTIONS e^{x^2} AND e^{-x^2}	224
XI. THE PROBABILITY INTEGRAL P_{Δ}	225
XII. THE PROBABILITY INTEGRAL P_s	226
XIII. CHAUVENET'S CRITERION.....	226
XIV. FOR COMPUTING PROBABLE ERRORS BY FORMULÆ (31) AND (32).....	227
XV. FOR COMPUTING PROBABLE ERRORS BY FORMULÆ (34).....	228
XVI. SQUARES OF NUMBERS.....	229
XVII. LOGARITHMS; 1000 TO 1409.....	231
XVIII. LOGARITHMS.....	232
XIX. NATURAL SINES.....	234
XX. NATURAL COSINES.....	236
XXI. NATURAL TANGENTS.....	238
XXII. NATURAL COTANGENTS.....	240
XXIII. RADIAN MEASURE.....	242



THE THEORY OF MEASUREMENTS

CHAPTER I.

GENERAL PRINCIPLES.

I. Introduction. — Direct observation of the relative position and motion of surrounding objects and of their similarities and differences is the first step in the acquisition of knowledge. Such observations are possible only through the sensations produced by our environment, and the value of the knowledge thus acquired is dependent on the exactness with which we correlate these sensations. Such correlation involves a quantitative estimate of the relative intensity of different sensations and of their time and space relations. As our estimates become more and more exact through experience, our ideas regarding the objective world are gradually modified until they represent the actual condition of things with a considerable degree of precision.

The growth of science is analogous to the growth of ideas. Its function is to arrange a mass of apparently isolated and unrelated phenomena in systematic order and to determine the interrelations between them. For this purpose, each quantity that enters into the several phenomena must be quantitatively determined, while all other quantities are kept constant or allowed to vary by a measured amount. The exactness of the relations thus determined increases with the precision of the measurements and with the success attained in isolating the particular phenomena investigated.

A general statement, or a mathematical formula, that expresses the observed quantitative relation between the different magnitudes involved in any phenomenon is called the law of that phenomenon. As here used, the word law does not mean

that the phenomenon must follow the prescribed course, but that, under the given conditions and within the limits of error and the range of our measurements, it has never been found to deviate from that course. In other words, the laws of science are concise statements of our present knowledge regarding phenomena and their relations. As we increase the range and accuracy of our measurements and learn to control the conditions of experiment more definitely, the laws that express our results become more exact and cover a wider range of phenomena. Ultimately we arrive at broad generalizations from which the laws of individual phenomena are deducible as special cases.

The two greatest factors in the progress of science are the trained imagination of the investigator and the genius of measurement. To the former we owe the rational hypotheses that have pointed the way of advance and to the latter the methods of observation and measurement by which the laws of science have been developed.

2. Measurement and Units. — To measure a quantity is to determine the ratio of its magnitude to that of another quantity, of the same kind, taken as a unit. The number that expresses this ratio may be either integral or fractional and is called the *numeric* of the given quantity in terms of the chosen unit. In general, if Q represents the magnitude of a quantity, U the magnitude of the chosen unit, and N the corresponding numeric we have

$$Q = NU, \quad (\text{I})$$

which is the fundamental equation of measurement. The two factors N and U are both essential for the exact specification of the magnitude Q . For example: the length of a certain line is five inches, i.e., the line is five times as long as one inch. It is not sufficient to say that the length of the line is five; for in that case we are uncertain whether its length is five inches, five feet, or five times some other unit.

Obviously, the absolute magnitude of a quantity is independent of the units with which we choose to measure it. Hence, if we adopt a different unit U' , we shall find a different numeric N' such that

$$Q = N'U', \quad (\text{II})$$

and consequently

$$NU = N'U',$$

$$\text{or} \quad \frac{N}{N'} = \frac{U'}{U}. \quad (\text{III})$$

Equation (III) expresses the general principle involved in the transformation of units and shows that the numeric varies inversely as the magnitude of the unit; i.e., if U is twice as large as U' , N will be only one-half as large as N' . To take a concrete example: a length equal to ten inches is also equal to 25.4 centimeters approximately. In this case N equals ten, N' equals 25.4, U equals one inch, and U' equals one centimeter. The ratio of the numerics $\frac{N'}{N}$ is 2.54 and hence the inverse ratio of the units $\frac{U}{U'}$ is also 2.54, i.e., one inch is equal to 2.54 centimeters.

Equation (III) may also be written in the form

$$N = N' \frac{U'}{U}, \quad (\text{IV})$$

which shows that the numeric of a given quantity relative to the unit U is equal to its numeric relative to the unit U' multiplied by the ratio of the unit U' to the unit U . The ratio $\frac{U'}{U}$ is called the *conversion factor* for the unit U' in terms of the unit U . It is equal to the number of units U in one unit U' , and when multiplied by the numeric of a quantity in terms of U' gives the numeric of the same quantity in terms of U . The conversion factor for transformation in the opposite direction, i.e., from U to U' , is obviously the inverse of the above, or $\frac{U}{U'}$. In general, the numerator of the conversion factor is the unit in which the magnitude is already expressed and the denominator is the unit to which it is to be transformed. For example: one inch is approximately equal to 2.54 centimeters, hence the numeric of a length in centimeters is about 2.54 times its numeric in inches. Conversely, the numeric in inches is equal to the numeric in centimeters divided by 2.54 or multiplied by the reciprocal of this number.

In so far as the theory of mensuration and the attainable accuracy of the result are concerned, measurements may be made in terms of any arbitrary units and, in fact, the adoption of such

units is frequently convenient when we are concerned only with relative determinations. In general, however, measurements are of little value unless they are expressed in terms of generally accepted units whose magnitude is accurately known. Some such units have come into use through common consent but most of them have been fixed by government enactment and their permanence is assured by legal standards whose relative magnitudes have been accurately determined. Such primary standards, preserved by various governments, have, in many cases, been very carefully intercompared and their conversion factors are accurately known. Copies of the more important primary standards may be found in all well-equipped laboratories where they are preserved as the secondary standards to which all exact measurements are referred. Carefully made copies are, usually, sufficiently accurate for ordinary purposes, but, when the greatest precision is sought, their exact magnitude must be determined by direct comparison with the primary standards. The National Bureau of Standards at Washington makes such comparisons and issues certificates showing the errors of the standards submitted for test.

3. Fundamental and Derived Units. — Since the unit is, necessarily, a quantity of the same kind as the quantity measured, we must have as many different units as there are different kinds of quantities to be measured. Each of these units might be fixed by an independent arbitrary standard, but, since most measurable quantities are connected by definite physical relations, it is more convenient to define our units in accordance with these relations. Thus, measured in terms of any arbitrary unit, a uniform velocity is proportional to the distance described in unit time; but, if we adopt as our unit such a velocity that the unit of length is traversed in the unit of time, the factor of proportionality is unity and the velocity is equal to the ratio of the space traveled to the elapsed time.

Three independently defined units are sufficient, in connection with known physical relations, to fix the value of most of the other units used in physical measurements. We are thus led to distinguish two classes of units; the three fundamental units, defined by independent arbitrary standards, and the derived units, fixed by definite relations between the fundamental units. The magnitude, and to some extent the choice, of the fundamental

units is arbitrary, but when definite standards for each of these units have been adopted the magnitude of all of the derived units is fixed.

For convenience in practice, legal standards have been adopted to represent some of the derived units. The precision of these standards is determined by indirect comparison with the standards representing the three fundamental units. Such comparisons are based on the known relations between the fundamental and derived units and are called absolute measurements. The practical advantage gained by the use of derived standards lies in the fact that absolute measurements are generally very difficult and require great skill and experience in order to secure a reasonable degree of accuracy. On the other hand, direct comparison of derived quantities of the same kind is often a comparatively simple matter and can be carried out with great precision.

4. Dimensions of Units.—The dimensions of a unit is a mathematical formula that shows how its magnitude is related to that of the three fundamental units. In writing such formulæ, the variables are usually represented by capital letters inclosed in square brackets. Thus, $[M]$, $[L]$ and $[T]$ represent the dimensions of the units of mass, length and time respectively.

Dimensional formulæ and ordinary algebraic equations are essentially different in significance. The former shows the relative variation of units, while the latter expresses a definite mathematical relation between the numerics of measurable quantities. Thus if a point in uniform motion describes the distance L in the time T its velocity V is defined by the relation

$$V = \frac{L}{T}. \quad (\text{V})$$

Since L and T are concrete quantities of different kind, the right-hand member of this equation is not a ratio in the strict arithmetical sense; i.e., it cannot be represented by a simple abstract number. Hence, in virtue of the definite physical relation expressed by equation (V), we are led to extend our idea of ratio to include the case of concrete quantities. From this point of view, the ratio of two quantities expresses the rate of change of the first quantity with respect to the second. It is a concrete quantity of the same kind as the quantity it serves to define. As an illustration, consider the meaning of equation (V). Expressed in words, it is "the

velocity of a point, in uniform motion, is equal to the time rate at which it moves through space."

If we represent the units of velocity, length, and time by $[V]$, $[L]$, and $[T]$, respectively, and the corresponding numerics by v , l , and t , we have by equation (I), article two,

$$V = v[V], \quad L = l[L], \quad T = t[T],$$

and equation (V) becomes

$$v[V] = \frac{[L]}{[T]} \cdot \frac{l}{t},$$

or

$$v = \frac{[L]}{[V][T]} \cdot \frac{l}{t}. \quad (\text{VI})$$

Since, by definition, $[V]$ and $\frac{[L]}{[T]}$ are quantities of the same kind, their ratio can be expressed by an abstract number k and equation (VI) may be written in the form

$$v = k \frac{l}{t}, \quad (\text{VII})$$

which is an exact numerical equation containing no concrete quantities.

The numerical value of the constant k obviously depends on the units with which L , T , and V are measured. If we define the unit of velocity by the relation

$$[V] = \frac{[L]}{[T]},$$

or, as it is more often written,

$$[V] = [LT^{-1}], \quad (\text{VIII})$$

k becomes equal to unity and the relation (VII) between the numerics of velocity, length, and time reduces to the simple form

$$v = \frac{l}{t}. \quad (\text{IX})$$

The foregoing argument illustrates the advantage to be gained by defining derived units in accordance with the physical relations on which they depend. By this means we eliminate the often incommensurable constants of proportionality such as k would be if the unit of velocity were defined in any other way than by equation (VIII).

The expression on the right-hand side of equation (VIII) is the dimensions of the unit of velocity when the units of length, mass, and time are chosen as fundamental. The dimensions of any other units may be obtained by the method outlined above when we know the physical relations on which they depend. The form of the dimensional formula depends on the units we choose as fundamental, but the general method of derivation is the same in all cases. As an exercise to fix these ideas the student should verify the following dimensional formulæ: choosing $[M]$, $[L]$, and $[T]$ as fundamental units, the dimensions of the units of area, acceleration, and force are $[L^2]$, $[LT^{-2}]$, and $[MLT^{-2}]$ respectively. As an illustration of the effect of a different choice of fundamental units, it may be shown that the dimensions of the unit of mass is $[FL^{-1}T^2]$ when the units of length $[L]$, force $[F]$, and time $[T]$ are chosen as fundamental. The dimensions of some important derived units are given in Table I at the end of this volume.

5. Systems of Units in General Use. — Consistent systems of units may differ from one another by a difference in the choice of fundamental units or by a difference in the magnitude of the particular fundamental units adopted. The systems in common use illustrate both types of difference.

Among scientific men, the so-called c.g.s. system is almost universally adopted, and the results of scientific investigations are seldom expressed in any other units. The advantage of such uniformity of choice is obvious. It greatly facilitates the comparison of the results of different observers and leads to general advance in our knowledge of the phenomena studied. The units of length, mass, and time are chosen as fundamental in this system and the particular values assigned to them are the centimeter for the unit of length, the gram for the unit of mass, and the mean solar second for the unit of time.

The units used commercially in England and the United States of America are far from systematic, as most of the derived units are arbitrarily defined. So far as they follow any order, they form a length-mass-time system in which the unit of length is the foot, the unit of mass is the mass of a pound, and the unit of time is the second. This system was formerly used quite extensively by English scientists and the results of some classic investigations are expressed in such units.

English and American engineers find it more convenient to use

a system in which the fundamental units are those of length, force, and time. The particular units chosen are the foot as the unit of length, the pound's weight at London as the unit of force, and the mean solar second as the unit of time. We shall see that this is equivalent to a length-mass-time system in which the units of length and time are the same as above and the unit of mass is the mass of 32.191 pounds.

6. Transformation of Units. — When the relative magnitude of corresponding fundamental units in two systems is known, a result expressed in one system can be reduced to the other with the aid of the dimensions of the derived units involved. Thus: let A_c represent the magnitude of a square centimeter, A_i the magnitude of a square inch, N_c the numeric of a given area when measured in square centimeters, and N_i the numeric of the same area when measured in square inches; then, from equation (IV), article two, we have

$$N_i = N_c \frac{A_c}{A_i}.$$

But if L_c is the magnitude of a centimeter and L_i that of an inch, A_i is equal to L_i^2 , and therefore

$$\frac{A_c}{A_i} = \frac{L_c^2}{L_i^2} = \left(\frac{L_c}{L_i}\right)^2.$$

Hence, the conversion factor $\frac{A_c}{A_i}$ for reducing square centimeters to square inches is equal to the square of the conversion factor $\frac{L_c}{L_i}$ for reducing from centimeters to inches. Now the dimensions of the unit of area is $[L^2]$, and we see that the conversion factor for area may be obtained by substituting the corresponding conversion factor for lengths in this dimensional formula. This is a simple illustration of the general method of transformation of units. When the fundamental units in the two systems differ in magnitude, but not in kind, the conversion factor for corresponding derived units in the two systems is obtained by replacing the fundamental units by their respective conversion factors in the dimensions of the derived units considered.

It should be noticed that the fundamental units in the c.g.s. system are those of length, mass, and time, while on the engineer's system they are length, force, and time. In the latter system,

force is supposed to be directly measured and expressed by the dimensions $[F]$. Consequently the dimensions of the unit of mass are $[FL^{-1}T^2]$, and the unit of mass is a mass that will acquire a velocity of one foot per second in one second when acted upon by a force of one pound's weight. For the sake of definiteness, the unit of force is taken as the pound's weight at London, where the acceleration due to gravity (g) is equal to 32.191 feet per second per second. Otherwise the unit of force would be variable, depending on the place at which the pound is weighed.

From Newton's second law of motion we know that the relation between acceleration, mass, and force is given by the expression

$$f = ma.$$

For a constant force the acceleration produced is inversely proportional to the mass moved. Now the mass of a pound at London is acted upon by gravity with a force of one pound's weight, and, if free, it moves with an acceleration of 32.191 feet per second per second. Hence a mass equal to that of 32.191 pounds acted upon by a force of one pound's weight would move with an acceleration of one foot per second per second, i.e., it would acquire a velocity of one foot per second in one second. Hence the unit of mass in the engineer's system is 32.191 pounds mass. This unit is sometimes called a slug, but the name is seldom met with since engineers deal primarily with forces rather than masses, and are content to write $\frac{W}{g}$ for mass without giving the unit a definite name. This is equivalent to saying that the mass of a body, expressed in slugs, is equal to its weight, at London, expressed in pounds, divided by 32.191.

After careful consideration of the foregoing discussion, it will be evident that the engineer's length-force-time system is exactly equivalent to a length-mass-time system in which the unit of length is the foot, the unit of mass is the slug or 32.191 pounds' mass, and the unit of time is the mean solar second. In the latter system the fundamental units are of the same kind as those of the c.g.s. system. Hence, if the conversion factor for the unit of mass is taken as the ratio of the magnitude of the slug to that of the gram, quantities expressed in the units of the engineer's system may be reduced to the equivalent values in the c.g.s. system by the method described at the beginning of this article.

When, as is frequently the case, the engineer's results are expressed in terms of the local weight of a pound as a unit of force in place of the pound's weight at London, the result of a transformation of units, carried out as above, will be in error by a factor equal to the ratio of the acceleration due to gravity at London and at the location of the measurements. Unless the local gravitational acceleration is definitely stated by the observer and unless he has used his length-force-time units in a consistent manner, it is impossible to derive the exact equivalent of his results on the c.g.s. system.

CHAPTER II.

MEASUREMENTS.

IN article two of the last chapter we defined the term "measurement" and showed that any magnitude may be represented by the product of two factors, the numeric and the unit. The object of all measurements is the determination of the numeric that expresses the magnitude of the observed quantity in terms of the chosen unit. For convenience of treatment, they may be classified according to the nature of the measured quantity and the methods of observation and reduction.

7. Direct Measurements. — The determination of a desired numeric by direct observation of the measured quantity, with the aid of a divided scale or other indicating device graduated in terms of the chosen unit, is called a direct measurement.

Such measurements are possible when the chosen unit, together with its multiples and submultiples, can be represented by a material standard, so constructed that it can be directly applied to the measured quantity for the purpose of comparison, or when the unit and the measured magnitudes produce proportional effects on a suitable indicating device.

Lengths may be directly measured with a graduated scale, masses by comparison with a set of standard masses on an equal arm balance, time intervals by the use of a clock regulated to give mean solar time, and forces with the aid of a spring balance. Hence magnitudes expressible in terms of the fundamental units of either the c.g.s. or the engineer's system may be directly measured.

Many quantities expressible in terms of derived units, that can be represented by material standards, are commonly determined by direct measurement. As illustrations, we may cite the determination of the volume of a liquid with a graduated flask and the measurement of the electrical resistance of a wire by comparison with a set of standard resistances.

8. Indirect Measurements. — The determination of a desired numeric by computation from the numerics of one or more

directly measured magnitudes, that bear a known relation to the desired quantity, is called an indirect measurement.

The relation between the observed and computed magnitudes may be expressed in the general form

$$y = F(x_1, x_2, x_3, \dots a, b, c \dots),$$

where y , x_1 , x_2 , etc., represent measured or computed magnitudes, or the numerics corresponding to them, a , b , c , etc., represent constants, and F indicates that there is a functional relation between the other quantities. This expression is read, y equals some function of x_1 , x_2 , etc., and a , b , c , etc. In any particular case, the form of the function F and the number and nature of the related quantities must be known before the computation of the unknown quantities is undertaken.

Most of the indirect measurements made by physicists and engineers fall into one or another of three general classes, characterized by the nature of the unknown and measured magnitudes and the form of the function F .

9. Classification of Indirect Measurements.

I.

In the first class, y represents the desired numeric of a magnitude that is not directly measured, either because it is impossible or inconvenient to do so, or because greater precision can be attained by indirect methods. The form of the function F and the numerical values of all of the constants a , b , c , etc., appearing in it, are given by theory. The quantities x_1 , x_2 , etc., represent the numerics of directly measured magnitudes. In the following pages indirect measurements belonging to this class will sometimes be referred to as derived measurements.

As an illustration we may cite the determination of the density s of a solid sphere from direct measurements of its mass M and its diameter D with the aid of the relation

$$s = \frac{M}{\frac{1}{6} \cdot \pi D^3}.$$

Comparing this expression with the general formula given above, we note that s corresponds to y , M to x_1 , D to x_2 , $\frac{1}{6}$ to a , π to b , and that F represents the function $\frac{M}{\frac{1}{6} \pi D^3}$. The form of the func-

tion is given by the definition of density as the ratio of the mass to the volume of a body and the numerical constants $\frac{1}{6}$ and π are given by the known relation between the volume and diameter of a sphere.

II.

In the second class of indirect measurements, the numerical constants a, b, c , etc., are the unknown quantities to be computed, the form of the function F is known, and all of the quantities y, x_1, x_2 , etc., are obtained by direct measurements or given by theory. The functions met with in this class of measurements usually represent a continuous variation of the quantity y with respect to the quantities x_1, x_2 , etc., as independent variables. Hence the result of a direct measurement of y will depend on the particular values of x_1, x_2 , etc., that obtain at the time of the measurement. Consequently, in computing the constants a, b, c , etc., we must be careful to use only corresponding values of the measured quantities, i.e., values that are, or would be, obtained by coincident observations on the several magnitudes.

Every set of corresponding values of the variables y, x_1, x_2 , etc., when used in connection with the given function, gives an algebraic relation between the unknown quantities a, b, c , etc., involving only numerical coefficients and absolute terms. When we have obtained as many independent equations as there are unknown quantities, the latter may be determined by the usual algebraic methods. We shall see, however, that more precise results can be obtained when the number of independent measurements far exceeds the minimum limit thus set and the computation is made by special methods to be described hereafter.

The determination of the initial length L_0 and the coefficient of linear expansion a of a metallic bar from a series of measurements of the lengths L_t corresponding to different temperatures t with the aid of the functional relation

$$L_t = L_0 (1 + at)$$

is an example of the class of measurements here considered. Such measurements are sometimes called determinations of empirical constants.

III.

The third class of indirect measurements includes all cases in which each of a number of directly measured quantities y_1, y_2, y_3 , etc., is a given function of the unknown quantities x_1, x_2, x_3 , etc., and certain known numerical constants a, b, c , etc. In such cases we have as many equations of the form

$$y_1 = F_1(x_1, x_2, x_3, \dots, a, b, c, \dots),$$

$$y_2 = F_2(x_1, x_2, x_3, \dots, a, b, c, \dots),$$

.

as there are measured quantities y_1, y_2 , etc. This number must be at least as great as the number of unknowns x_1, x_2 , etc., and

may be much greater. The functions F_1, F_2 , etc., are frequently different in form and some of them may not contain all of the unknowns. The numerical constants, appearing in different functions, are generally different. But the form of each of the functions and the values of all of the constants must be known before a solution of the problem is possible.

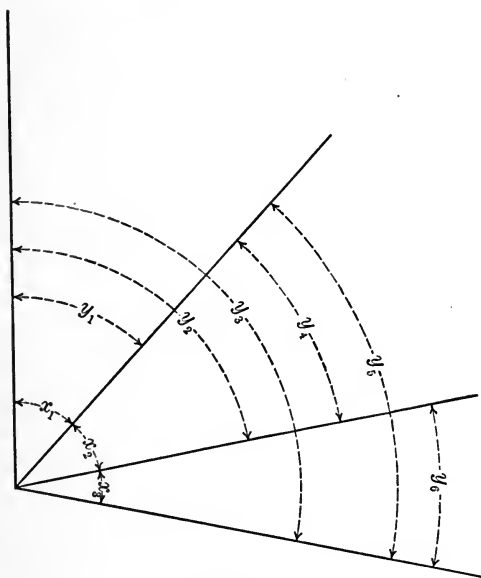

FIG. 1.

Problems of this type are frequently met with in astronomy and geodesy.

One of the simplest is known as the adjustment of the angles about a point. Thus, let it be required to find the most probable values of the angles x_1, x_2 , and x_3 , Fig. 1, from direct measurements of $y_1, y_2, y_3, \dots, y_6$. In this case the general equations take the form

$$y_1 = x_1,$$

$$y_2 = x_1 + x_2,$$

$$y_3 = x_1 + x_2 + x_3,$$

$$y_4 = x_2,$$

$$y_5 = x_2 + x_3,$$

$$y_6 = x_3,$$

and all of the numerical constants are either unity or zero. The solution of such problems will be discussed in the chapter on the method of least squares.

10. Determination of Functional Relations. — When the form of the functional relation between the observed and unknown magnitudes is not known, the solution of the problem requires something more than measurement and computation. In some cases a study of the theory of the observed phenomena, in connection with that of allied phenomena, will suggest the form of the required function. Otherwise, a tentative form must be assumed after a careful study of the observations themselves, generally by graphical methods. In either case the constants of the assumed function must be determined by indirect measurements and the results tested by a comparison of the observed and the computed values of the related quantities. If these values agree within the accidental errors of observation, the assumed function may be adopted as an empirical representation of the phenomena. If the agreement is not sufficiently close, the form of the function is modified, in a manner suggested by the observations, and the process of computation and comparison is repeated until a satisfactory agreement is obtained. A more detailed treatment of such processes will be found in Chapter XIII.

11. Adjustment, Setting, and Observation of Instruments. — Most of the magnitudes dealt with in physics and engineering are determined by indirect measurements. But we have seen that all such quantities are dependent upon and computed from directly measured quantities. Consequently, a study of the methods and precision of direct measurement is of fundamental importance.

In general, every direct measurement involves three distinct operations. First: the instrument adopted is so placed that its

scale is in the proper position relative to the magnitude to be measured and all of its parts operate smoothly in the manner and direction prescribed by theory. Operations of this nature are called adjustments. Second: the reference line of the instrument is moved, or allowed to move, in the manner demanded by theory, until it coincides with a mark chosen as a point of reference on the measured magnitude. We shall refer to this operation as a setting of the instrument. Third: the position of the index of the instrument, with respect to its graduated scale, is read. This is an observation.

As an illustration, consider the measurement of the normal distance between two parallel lines with a micrometer microscope. The instrument must be so mounted that it can be rigidly clamped in any desired position or moved freely in the direction of its optical axis without disturbing the direction of the micrometer screw. The following adjustments are necessary: the axis of the micrometer screw must be made parallel to the plane of the two lines and perpendicular to a normal plane through one of them; the eyepiece must be so placed that the cross-hairs are sharply defined; the microscope must be moved, in the direction of its optical axis, until the image of the two lines, or one of them if the normal distance between them is greater than the field of view of the microscope, is in the same plane with the cross-hairs. The latter adjustment is correct when there is no parallax between the image of the lines and the cross-hairs. The setting is made by turning the micrometer head until the intersection of the cross-hairs bisects the image of one of the lines. Finally the reading of the micrometer scale is observed. A similar setting and observation are made on the other line and the difference between the two observations gives the normal distance between the two lines in terms of the scale of the micrometer.

12. Record of Observations. — In the preceding article, the word "observation" is used in a very much restricted sense to indicate merely the scale reading of a measuring instrument. This restriction is convenient in dealing with the technique of measurement, but many other circumstances, affecting the accuracy of the result, must be observed and taken into account in a complete study of the phenomena considered. There is, however, little danger of confusion in using the word in the two different senses since the more restricted meaning is in reality only a

special case of the general. The particular significance intended in any special case is generally clear from the context.

The first essential for accurate measurements is a clear and orderly record of all of the observations. The record should begin with a concise description of the magnitude to be measured, and the instruments and methods adopted for the purpose. Instruments may frequently be described, with sufficient precision, by stating their name and number or other distinguishing mark. Methods are generally specified by reference to theoretical treatises or notes. The adjustment and graduation of the instruments should be clearly stated. The date on which the work is carried out and the location of the apparatus should be noted.

Observations, in the restricted sense, should be neatly arranged in tabular form. The columns of the table should be so headed, and referred to by subsidiary notes, that the exact significance of all of the recorded figures will be clearly understood at any future time. All circumstances likely to affect the accuracy of the measurements should be carefully observed and recorded in the table or in suitably placed explanatory notes.

Observations should be recorded exactly as taken from the instruments with which they are made, without mental computation or reduction of any kind even the simplest. For example: when a micrometer head is divided into any number of parts other than ten or one hundred, it is better to use two columns in the table and record the reading of the main scale in one and that of the micrometer head in the other than to reduce the head reading to a decimal mentally and enter it in the same column with the main scale reading. This is because mistakes are likely to be made in such mental calculations, even by the most experienced observers, and, when the final reduction of the observations is undertaken at a future time, it is frequently difficult or impossible to decide whether a large deviation of a single observation from the mean of the others is due to an accidental error of observation or to a mistake in such a mental calculation.

13. Independent, Dependent, and Conditioned Measurements. — Measurements on the same or different magnitudes are said to be independent when both of the following specifications are fulfilled: first, the measured magnitudes are not required to satisfy a rigorous mathematical relation among themselves; second, the same observation is not used in the computation of

any two of the measurements and the different observations are entirely unbiased by one another.

When the first of these specifications is fulfilled and the second is not, the measurements are said to be dependent. Thus, when several measurements of the length of a line are all computed from the same zero reading of the scale used, they are all dependent on that observation and any error in the position of the zero mark affects all of them by exactly the same amount. When the position of the index relative to the scale of the measuring instrument is visible while the settings are being made, there is a marked tendency to set the instrument so that successive observations will be exactly alike rather than to make an independent judgment of the bisection of the chosen mark in each case. The observations, corresponding to settings made in this manner, are biased by a preconceived notion regarding the correct position of the index and the measurements computed from them are not independent. The importance of avoiding faulty observations of this type cannot be too strongly emphasized. They not only vitiate the results of our measurements, but also render a determination of their precision impossible.

Measurements that do not satisfy the first of the above specifications are called conditioned measurements. The different determinations of each of the related quantities may or may not be independent, according as they do or do not satisfy the second specification, but the adjusted results of all of the measurements must satisfy the given mathematical relation. Thus, we may make a number of independent measurements of each of the angles of a plane triangle, but the mean results must be so adjusted that the sum of the accepted values is equal to one hundred and eighty degrees.

14. Errors and the Precision of Measurements. — Owing to unavoidable imperfections and lack of constant sensitiveness in our instruments, and to the natural limit to the keenness of our senses, the results of our observations and measurements differ somewhat from the true numeric of the observed magnitude. Such differences are called errors of observation or measurement. Some of them are due to known causes and can be eliminated, with sufficient accuracy, by suitable computations. Others are apparently accidental in nature and arbitrary in magnitude. Their probable distribution, in regard to magnitude and frequency

of occurrence, can be determined by statistical methods when a sufficient number of independent measurements is available.

The precision of a measurement is the degree of approximation with which it represents the true numeric of the observed magnitude. Usually our measurements serve only to determine the probable limits within which the desired numeric lies. Looked at from this point of view, the precision of a measurement may be considered to be inversely proportional to the difference between the limits thus determined. It increases with the accuracy, adaptability, and sensitiveness of the instruments used, and with the skill and care of the observer. But, after a very moderate precision has been attained, the labor and expense necessary for further increase is very great in proportion to the result obtained.

A measurement is of little practical value unless we know the precision with which it represents the observed magnitude. Hence the importance of a thorough study of the nature and distribution of errors in general and of the particular errors that characterize an adopted method of measurement. At first sight it might seem incredible that such errors should follow a definite mathematical law. But, when the number of observations is sufficiently great, we shall see that the theory of probability leads to a definite and easily calculated measure of the precision of a single observation and of the result computed from a number of observations.

15. Use of Significant Figures. — When recording the numerical results of observations or measurements, and during all of the necessary computations, the number of significant figures employed should be sufficient to express the attained precision and no more. By significant figures we mean the nine digits and zeros when not used merely to locate the decimal point.

In the case of the direct observation of the indications of instruments, the above specification is usually sufficiently fulfilled by allowing the last recorded significant figure to represent the estimated tenth of the smallest division of the graduated scale. For example: in measuring the length of a line, with a scale divided in millimeters, the position of the ends of the line would be recorded to the nearest estimated tenth of a millimeter.

Generally, computed results should be so recorded that the limiting values, used to express the attained precision, differ by only a few units in the last one or two significant figures. Thus:

if the length of a line is found to lie between 15.65 millimeters and 15.72 millimeters, we should write 15.68 millimeters as the result of our measurement. The use of a larger number of significant figures would be not only a waste of space and labor, but also a false representation of the precision of the result. Most of the magnitudes we are called upon to measure are incommensurable with the chosen unit, and hence there is no limit to the number of significant figures that might be used if we chose to do so; but experienced observers are always careful to express all observations and results and carry out all computations with a number just sufficient to represent the attained precision. The use of too many or too few significant figures is strong evidence of inexperience or carelessness in making observations and computations. More specific rules for determining the number of significant figures to be used in special cases will be developed in connection with the methods for determining the precision of measurements.

The number of significant figures in any numerical expression is entirely independent of the position of the decimal point. Thus: each of the numbers 5,769,000, 5769, 57.69, and 0.0005769 is expressed by four significant figures and represents the corresponding magnitude within one-tenth of one per cent, notwithstanding the fact that the different numbers correspond to different magnitudes. In general, the location of the decimal point shows the order of magnitude of the quantity represented and the number of significant figures indicates the precision with which the actual numeric of the quantity is known.

In writing very large or very small numbers, it is convenient to indicate the position of the decimal point by means of a positive or negative power of ten. Thus: the number 56,400,000 may be written 564×10^5 or, better, 5.64×10^7 , and 0.000075 may be written 75×10^{-6} or 7.5×10^{-5} . When a large number of numerical observations or results are to be tabulated or used in computation, a considerable amount of time and space is saved by adopting this method of representation. The second of the two forms, illustrated above, is very convenient in making computations by means of logarithms, as in this case the power of ten always represents the characteristic of the logarithm of the corresponding number.

In rounding numbers to the required number of significant figures, the digit in the last place held should be increased by one

unit when the digit in the next lower place is greater than five, and left unchanged when the neglected part is less than five-tenths of a unit. When the neglected part is exactly five-tenths of a unit the last digit held is increased by one if odd, and left unchanged if even. Thus: 5687.5 would be rounded to 5688 and 5686.5 to 5686.

16. Adjustment of Measurements.—The results of independent measurements of the same magnitude by the same or different methods seldom agree with one another. This is due to the fact that the probability for the occurrence of errors of exactly the same character and magnitude in the different cases is very small indeed. Hence we are led to the problem of determining the best or most probable value of the numeric of the observed magnitude from a series of discordant measurements. The given data may be all of the same precision or it may be necessary to assign a different degree of accuracy to the different measurements. In either case the solution of the problem is called the adjustment of the measurements.

The principle of least squares, developed in the theory of errors that leads to the measure of precision cited above, is the basis of all such adjustments. But the particular method of solution adopted in any given case depends on the nature of the measurements considered. In the case of a series of direct, equally precise, measurements of a single quantity, the principle of least squares leads to the arithmetical mean as the most probable, and therefore the best, value to assign to the measured quantity. This is also the value that has been universally adopted on *a priori* grounds. In fact many authors assume the maximum probability of the arithmetical mean as the axiomatic basis for the development of the law of errors.

The determination of empirical relations between measured quantities and the constants that enter into them is also based on the principle of least squares. For this reason, such determinations are treated in connection with the discussion of the methods for the adjustment of measurements.

17. Discussion of Instruments and Methods.—The theory of errors finds another very important application in the discussion of the relative availableness and accuracy of different instruments and methods of measurement. Used in connection with a few preliminary measurements and a thorough knowledge of the

theory of the proposed instruments and methods, it is sufficient for the determination of the probable precision of an extended series of careful observations. By such means we are able to select the instruments and methods best adapted to the particular purpose in view. We also become acquainted with the parts of the investigation that require the greatest skill and care in order to give a result with the desired precision.

The cost of instruments and the time and skill required in carrying out the measurements increase much more rapidly than the corresponding precision of the results. Hence these factors must be taken into account in determining the availableness of a proposed method. It is by no means always necessary to strive for the greatest attainable precision. In fact, it would be a waste of time and money to carry out a given measurement with greater precision than is required for the use to which it is to be put. For many practical purposes, a result correct within one-tenth of one per cent, or even one per cent, is amply sufficient. In such cases it is essential to adopt apparatus and methods that will give results definitely within these limits without incurring the greater cost and labor necessary for more precise determinations.

CHAPTER III.

CLASSIFICATION OF ERRORS.

ALL measurements, of whatever nature, are subject to three distinct classes of errors, namely, constant errors, mistakes, and accidental errors.

18. Constant Errors. — Errors that can be determined in sign and magnitude by computations based on a theoretical consideration of the method of measurement used or on a preliminary study and calibration of the instruments adopted are called constant errors. They are sometimes due to inadequacy of an adopted method of measurement, but more frequently to inaccurate graduation and imperfect adjustment of instruments.

As a simple illustration, consider the measurement of the length of a straight line with a graduated scale. If the scale is not held exactly parallel to the line, the result will be too great or too small according as the line of sight in reading the scale is normal to the line or to the scale. The magnitude of the error thus introduced depends on the angle between the line and the scale and can be exactly computed when we know this angle and the circumstances of the observations. If the scale is not straight, if its divisions are irregular, or if they are not of standard length, the result of the measurement will be in error by an amount depending on the magnitude and distribution of these inaccuracies of construction. The sign and magnitude of such errors can generally be determined by a careful study and calibration of the scale.

If M represents the actual numeric of the measured magnitude, M_0 the observed numeric, and C_1, C_2, C_3 , etc., the constant errors inherent in the method of measurement and the instruments used,

$$M = M_0 + C_1 + C_2 + C_3 + \dots \quad (1)$$

The necessary number of correction terms C_1, C_2, C_3 , etc., is determined by a careful study of the theory and practical application of the apparatus and method used in finding M_0 . The magnitude and sign of each term are determined by subsidiary

measurements or calculated, on theoretical grounds, from known data. Thus, in the above illustration, suppose that the scale is straight and uniformly graduated, that each of its divisions is 1.01 times as long as the unit in which it is supposed to be graduated, and that the line of the graduations makes an angle α with the line to be measured. Under these conditions, the number of correction terms reduces to two: the first, C_1 , due to the false length of the scale divisions, and the second, C_2 , due to the lack of parallelism between the scale and the line.

Since the actual length of each division is 1.01, the length of M_0 divisions, i.e., the length that would have been observed on an accurate scale, is

$$M_1 = M_0 \times 1.01 = M_0 + 0.01 M_0 = M_0 + C_1, \\ \therefore C_1 = + 0.01 M_0.$$

If the line of sight is normal to the line in making the observations, the length M_2 that would have been obtained if the scale had been properly placed is

$$M_2 = M_0 \cos \alpha = M_0 + C_2, \\ \therefore C_2 = - M_0 (1 - \cos \alpha) = - 2 M_0 \sin^2 \frac{\alpha}{2},$$

and (1) takes the form

$$M = M_0 + 0.01 M_0 - 2 M_0 \sin^2 \frac{\alpha}{2}, \\ = M_0 \left(1 + 0.01 - 2 \sin^2 \frac{\alpha}{2} \right).$$

The precision with which it is necessary to determine the correction terms C_1 , C_2 , etc., and frequently the number of these terms that should be employed depends on the precision with which the observed numeric M_0 is determined. If M_0 is measured within one-tenth of one per cent of its magnitude, the several correction terms should be determined within one one-hundredth of one per cent of M_0 , in order that the neglected part of the sum of the corrections may be less than one-tenth of one per cent of M_0 . If any correction term is found to be less than the above limit, it may be neglected entirely since it is obviously useless to apply a correction that is less than one-tenth of the uncertainty of M_0 .

In our illustration, suppose that the precision is such that we are sure that M_0 is less than 1.57 millimeters and greater than

1.55 millimeters, but is not sufficient to give the fourth significant figure within several units. Obviously, it would be useless to determine C_1 and C_2 closer than 0.001 millimeter, and if the magnitude of either of these quantities is less than 0.001 millimeter our knowledge of the true value of M is not increased by making the corresponding correction. In fact, it is usually impossible to determine the C 's with greater accuracy than the above limit, since, as in our illustration, M_0 is usually a factor in the correction terms. Hence the writing down of more than the required number of significant figures is mere waste of labor.

When considering the availableness of proposed methods and apparatus, it is important to investigate the nature and magnitude of the constant errors inherent in their use. It sometimes happens that the sources of such errors can be sufficiently eliminated by suitable adjustment of the instruments or modification of the method of observation. When this is not possible the conditions should be so chosen that the correction terms can be computed with the required precision. Even when all possible precautions have been taken, it very seldom happens that the sum of the constant errors reduces to zero or that the magnitude of the necessary corrections can be exactly determined. Moreover, such errors are never rigorously constant, but present small fortuitous variations, which, to some extent, are indistinguishable from the accidental errors to be described later.

A more detailed discussion of constant errors and the limits within which they should be determined will be given after we have developed the methods for estimating the precision of the observed numeric M .

19. Personal Errors. — When setting cross-hairs, or any other indicating device, to bisect a chosen mark, some observers will invariably set too far to one side of the center, while others will as consistently set on the other side. Again, in timing a transit, some persons will signal too soon and others too late. With experienced and careful observers, the errors introduced in this manner are small and nearly constant in magnitude and sign, but they are seldom entirely negligible when the highest possible precision is sought.

Errors of this nature will be called personal errors, since their magnitude and sign depend on personal peculiarities of the observer. Their elimination may sometimes be effected by a

careful study of the nature of such peculiarities and the magnitude of the effects produced by them under the conditions imposed by the particular problem considered. Suitable methods for this purpose are available in connection with most of the investigations in which an exact knowledge of the personal error is essential. Such a study is frequently referred to as a determination of the "Personal Equation" of the observer.

20. Mistakes. — Mistakes are errors due to reading the indications of an instrument carelessly or to a faulty record of the observations. The most frequent of these are the following: the wrong integer is placed before an accurate fractional reading, e.g., 9.68 for 19.68; the reading is made in the wrong direction of the scale, e.g., 6.3 for 5.7; the significant figures of a number are transposed, e.g., 56 is written for 65. Care and strict attention to the work in hand are the only safeguards against such mistakes.

When a large number of observations have been systematically taken and recorded, it is sometimes possible to rectify an obvious mistake, but unless this can be done with certainty the offending observation should be dropped from the series. This statement does not apply to an observation showing a large deviation from the mean but only to obvious mistakes.

21. Accidental Errors. — When a series of independent measurements of the same magnitude have been made, by the same method and apparatus and with equal care, the results generally differ among themselves by several units in the last one or two significant figures. If in any case they are found to be identical, it is probable that the observations were not independent, the instruments adopted were not sufficiently sensitive, the maximum precision attainable was not utilized, or the observations were carelessly made. Exactly concordant measurements are quite as strong evidence of inaccurate observation as widely divergent ones.

As the accuracy of method and the sensitiveness of instruments is increased, the number of concordant figures in the result increases but differences always occur in the last attainable figures. Since there is, generally, no reason to suppose that any one of the measurements is more accurate than any other, we are led to believe that they are all affected by small unavoidable errors.

After all constant errors and mistakes have been corrected, the remaining differences between the individual measurements and the true

numeric of the measured magnitude are called accidental errors. They are due to the combined action of a large number of independent causes each of which is equally likely to produce a positive or a negative effect. Probably most of them have their origin in small fortuitous variations in the sensitiveness and adjustment of our instruments and in the keenness of our senses of sight, hearing, and touch. It is also possible that the correlation of our sense perceptions and the judgments that we draw from them are not always rigorously the same under the same set of stimuli.

Suppose that N measurements of the same quantity have been made by the same method and with equal care. Let $a_1, a_2, a_3, \dots a_N$ represent the several results of the independent measurements, after all constant errors and mistakes have been eliminated, and let X represent the true numeric of the measured magnitude. Then the accidental errors of the individual measurements are given by the differences,

$$\Delta_1 = a_1 - X, \Delta_2 = a_2 - X, \Delta_3 = a_3 - X, \dots \Delta_N = a_N - X. \quad (2)$$

The accidental errors $\Delta_1, \Delta_2, \dots \Delta_N$ thus defined are sometimes called the true errors of the observations $a_1, a_2, \dots a_N$.

22. Residuals. — Since the individual measurements $a_1, a_2, \dots a_N$ differ among themselves, and since there is no reason to suppose that any one of them is more accurate than any other, it is never possible to determine the exact magnitude of the numeric X . Hence the magnitude of the accidental errors $\Delta_1, \Delta_2, \dots \Delta_N$ can never be exactly determined. But, if x is the most probable value that we can assign to the numeric X on the basis of our measurements, we can determine the differences

$$r_1 = a_1 - x, \quad r_2 = a_2 - x, \quad \dots \quad r_N = a_N - x. \quad (3)$$

These differences are called the residuals of the individual measurements $a_1, a_2, \dots a_N$. They represent the most probable values that we can assign to the accidental errors $\Delta_1, \Delta_2, \dots \Delta_N$ on the basis of the given measurements.

It should be continually borne in mind that the residuals thus determined are never identical with the accidental errors. However precise our measurements may be, the probability that x is exactly equal to X is always less than unity. As the number and precision of measurements increase, the difference between

the magnitudes x and X decreases, and the residuals continually approach the accidental errors, but exact equality is never attainable with a finite number of observations.

23. Principles of Probability. — The theory of errors is an application of the principles of probability to the discussion of series of discordant measurements for the purpose of determining the most probable numeric that can be assigned to the measured quantity and making an estimate of the precision of the result thus obtained. A discussion of the fundamental principles of the theory of probability, sufficient for this purpose, is given in most textbooks on advanced algebra, and the student should master them before undertaking the study of the theory of errors.

For the sake of convenience in reference, the three most useful propositions are stated below without proof.

PROPOSITION 1. If an event can happen in n independent ways and either happen or fail in N independent ways, the probability p that it will occur in a single trial at random is given by the relation

$$p = \frac{n}{N}. \quad (4)$$

Also if p' is the probability that it will fail in a single trial at random,

$$p' = 1 - p = 1 - \frac{n}{N}. \quad (5)$$

PROPOSITION 2. If the probabilities for the separate occurrence of n independent events are respectively p_1, p_2, \dots, p_n , the probability P_S that some one of these events will occur in a single trial at random is given by the relation

$$P_S = p_1 + p_2 + p_3 + \dots + p_n. \quad (6)$$

PROPOSITION 3. If the probabilities for the separate occurrence of n independent events are respectively p_1, p_2, \dots, p_n , the probability P that all of the events will occur at the same time is given by the relation

$$P = p_1 \times p_2 \times \dots \times p_n. \quad (7)$$

CHAPTER IV.

THE LAW OF ACCIDENTAL ERRORS.

24. Fundamental Propositions. — The theory of accidental errors is based on the principle of the arithmetical mean and the three axioms of accidental errors. When the word "error" is used without qualification, in the statement of these propositions and in the following pages, accidental errors are to be understood.

Principle of the Arithmetical Mean. — The most probable value that can be assigned to the numeric of a measured magnitude, on the basis of a number of equally trustworthy direct measurements, is the arithmetical mean of the given measurements.

This proposition is self-evident in the case of two independent measurements, made by the same method with equal care, since one of them is as likely to be exact as the other, and hence it is more probable that the true numeric lies halfway between them than in any other location. Its extension to more than two measurements is the only rational assumption that we can make and is sanctioned by universal usage.

First Axiom. — In any large number of measurements, positive and negative errors of the same magnitude are equally likely to occur. The number of negative errors is equal to the number of positive errors.

Second Axiom. — Small errors are much more likely to occur than large ones.

Third Axiom. — All of the errors of the measurements in a given series lie between equal positive and negative limits. Very large errors do not occur.

The foundation of these propositions is the same as that of the axioms of geometry. Namely: they are general statements that are admitted as self-evident or accepted as a basis of argument by all competent persons. Their justification lies in the fact that the results derived from them are found to be in agreement with experience.

25. Distribution of Residuals. — It was pointed out in article twenty-two that the true accidental errors, represented by Δ 's,

cannot be determined in practice, but the residuals, represented by r 's, can be computed from the given observations by equation (3). The Δ 's may be considered as the limiting values toward which the r 's approach as the number of observations is indefinitely increased. If the residuals corresponding to a very large number of observations are arranged in groups according to sign and magnitude, the groups containing very small positive or negative residuals will be found to be the largest, and, in general, the magnitude of the groups will decrease nearly uniformly as the magnitude of the contained residuals increases either positively or negatively. Let n represent the number of residuals in any group, and r their common magnitude, then the distribution of the residuals, in regard to sign and magnitude, may be represented graphically by laying off ordinates proportional to the numbers n against

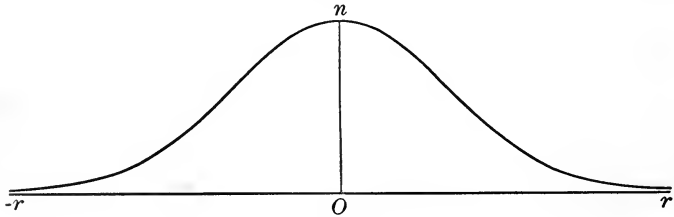

FIG. 2.

abscissæ proportional to the corresponding magnitudes r . The points, thus located, will be approximately uniformly distributed about a curve of the general form illustrated in Fig. 2.

The number of residuals in each group will increase with the total number of measurements from which the r 's are computed. Consequently the ordinates of the curve in Fig. 2 will depend on the number of observations considered as well as on their accuracy. Hence, if we wish to compare different series of measurements with regard to accuracy, we must in some way eliminate the effect of differences in the number of observations. Moreover, we are not so much concerned with the total number of residuals of any given magnitude as with the relative number of residuals of different magnitudes. For, as we shall see, the accuracy of a series of observations depends on the ratio of the number of small errors to the number of large ones.

26. Probability of Residuals. — Suppose that a very large number N of independent measurements have been made and that

the corresponding residuals have been computed by equation (3). By arranging the results in groups according to sign and magnitude, suppose we find n_1 residuals of magnitude r_1 , n_2 of magnitude r_2 , etc., and n_1' of magnitude $-r_1$, n_2' of magnitude $-r_2$, etc. If we choose one of the measurements at random, the probability that the corresponding residual is equal to r_1 is $\frac{n_1}{N}$, since there are N residuals and n_1 of them are equal to r_1 . In general, if $y_1, y_2, \dots, y_1', y_2', \dots$ represent the probabilities for the occurrence of residuals equal to $r_1, r_2, \dots, -r_1, -r_2, \dots$ respectively,

$$y_1 = \frac{n_1}{N}, \quad y_2 = \frac{n_2}{N}, \quad \dots \quad y_1' = \frac{n_1'}{N}, \quad y_2' = \frac{n_2'}{N}, \quad \dots \quad (8)$$

When N is increased by increasing the number of measurements, each of the n 's is increased in nearly the same ratio since the residuals of the new measurements are distributed in essentially the same manner as the old ones, provided all of the measurements considered are made by the same method and with equal care. Consequently, the y 's corresponding to a definite method of observation are nearly independent of the number of measurements. As N increases they oscillate, with continually decreasing amplitude, about the limiting values that would be obtained with an infinite number of observations. Hence the form of a curve, having y 's for ordinates and corresponding r 's for abscissæ, depends on the accuracy of the measurements considered and is sensibly independent of N , provided it is a large number.

27. The Unit Error.—The relative accuracy of different series of measurements might be studied with the aid of the corresponding $y : r$ curves, but since the y 's are abstract numbers, and the r 's are concrete, being of the same kind as the measurements, it is better to adopt a slightly different mode of representation. For this purpose, each of the r 's is divided by an arbitrary constant k , of the same kind as the measurements, and the abstract numbers $\frac{r_1}{k}, \frac{r_2}{k}$, etc., are used as abscissæ in place of the r 's. In the following pages, k will be called the *unit error*. Its magnitude may be arbitrarily chosen in particular cases, but, when not definitely specified to the contrary, it will be taken equal to the least magnitude that can be directly observed with the instruments and methods used in making the measurements. To

illustrate: suppose we are measuring a given length with a scale divided in millimeters. By estimation, the separate observations can be made to one-tenth of a millimeter. Hence, in this case we should take k equal to one-tenth of a millimeter.

If the residuals are arranged in the order of increasing magnitude, it is obvious that the successive differences $r_1 - r_0$, $r_2 - r_1$ etc., are all equal to k . Hence, if the most probable value of the measured quantity, x in equation (3), is taken to the same number of significant figures as the individual measurements, all of the residuals are integral multiples of k and we have

$$\begin{aligned} \frac{-r_p}{k} = -p; \quad \frac{-r_{(p-1)}}{k} = -(p-1); \quad \dots \quad \frac{-r_1}{k} = -1; \quad \frac{r_0}{k} = 0; \\ \frac{r_1}{k} = 1; \quad \dots \quad \frac{r_{(p-1)}}{k} = p-1; \quad \frac{r_p}{k} = p. \end{aligned}$$

28. The Probability Curve.—The result of a study of the distribution of the residuals may be arranged as illustrated in the following table, where n is the number of residuals of magnitude r ; y is the probability that a single residual, chosen at random, is of magnitude r ; N is the total number of measurements, and k is the unit error.

r	n	y	$\frac{r}{k}$
$-r_p$	n'_p	$\frac{n'_p}{N}$	$-p$
..
..
$-r_1$	n'_1	$\frac{n'_1}{N}$	-1
r_0	n_0	$\frac{n_0}{N}$	0
r_1	n_1	$\frac{n_1}{N}$	$+1$
..
..
r_p	n_p	$\frac{n_p}{N}$	$+p$

Plotting y against $\frac{r}{k}$ we obtain $2p$ discrete points as in Fig. 3. When N is large, these points are somewhat symmetrically distributed about a curve of the general form illustrated by the dotted line. If a larger number of observations is considered,

some of the points will be shifted upward while others will be shifted downward, but the distribution will remain approximately symmetrical with respect to the same curve. In general, successive equal increments to N cause shifts of continually decreasing magnitude; and in the limit, when N becomes equal to infinity, and the residuals are equal to the accidental errors, the points would be on a uniform curve symmetrical to the y_0 ordinate. The curve thus determined represents the relation between the magnitude of an error and the probability of its occurrence in a given series of measurements. For this reason it is called the probability curve.

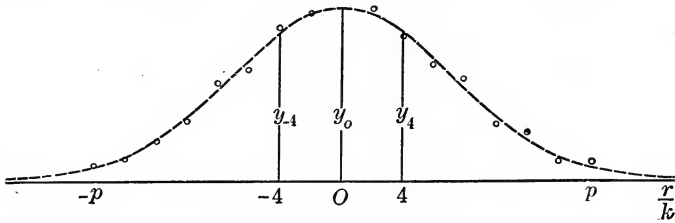

FIG. 3.

29. Systems of Errors.— The coördinates of the probability curve are y and $\frac{\Delta}{k}$, since it represents the distribution of the true accidental errors Δ_1, Δ_2 , etc., in regard to relative frequency and magnitude. Since the curve is uniform, it represents not only the errors of the actual observations, but also the distribution of all of the accidental errors that would be found if the sensitiveness of our instruments were infinitely increased and an infinite number of observations were made, provided only that all of the observations were made with the same degree of precision and entirely independently.

All of the errors represented by a curve of this type belong to a definite system, characterized by the magnitude of the maximum ordinate y_0 and the slope of the curve. Hence, every probability curve represents a definite system of errors. It also represents the accidental errors of a series of measurements of definite precision. Hence, the accidental errors of series of measurements of different precision belong to different systems, and each series is characterized by a definite system of errors.

The probability curves *A* and *B* in Fig. 4 represent the systems

of errors that characterize two series of measurements of different precision. As the precision of measurement is increased it is obvious that the number of small errors will increase relatively to the number of large ones. Consequently the probability of small errors will be greater and that of large ones will be less in the more precise series *A* than in the less precise series *B*. Hence, the curve *A* has a greater maximum ordinate and slopes more rapidly toward the horizontal axis than the curve *B*.

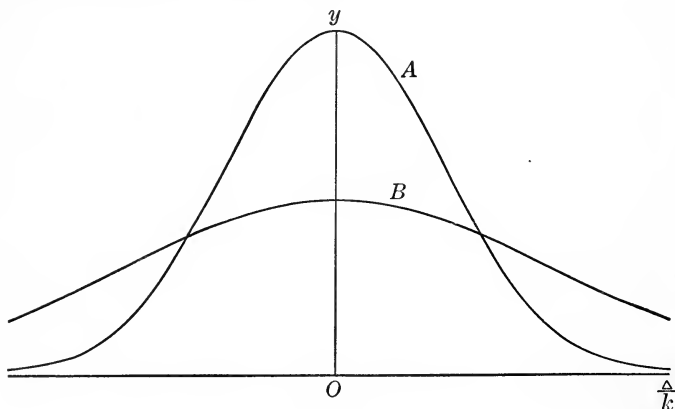

FIG. 4.

30. The Probability Function. — The maximum ordinate and the slope of the probability curve depend on the constants that appear in the equation of the curve. When we know the form of the equation and have a method of determining the numerical value of the constants, we are able to determine the relative precision of different series of measurements. Since the curve represents the distribution of the true accidental errors, we are also able to compare the distribution of these errors with that of the residuals and thus develop workable methods for finding the most probable numeric of the measured magnitude.

It is obvious, from an inspection of Figs. 3 and 4, that y is a continuous function of Δ , decreasing very rapidly as the magnitude of Δ increases either positively or negatively and symmetrical with respect to the y axis. Hence, the probability curve suggests an equation in the form

$$y = \omega e^{-\pi\omega^2 \frac{\Delta^2}{k^2}}, \quad (9)$$

where e is the base of the Napierian system of logarithms, ω is a constant depending on the precision of the series of measurements considered, and the other variables have been defined above. This equation can be derived analytically from the three axioms of accidental errors, with the aid of several plausible assumptions regarding the constitution of such errors, or from the principle of the arithmetical mean. However, the strongest evidence of its exactness lies in the fact that it gives results in substantial agreement with experience. Consequently, we will adopt it as an empirical relation, and proceed to show that it is in conformity with the three axioms and leads to the arithmetical mean as the most probable numeric derivable from a series of equally good independent measurements of the same magnitude.

Equation (9) is the mathematical expression of the law of accidental errors and is often referred to simply as the law of errors. Its right-hand member is called the probability function and, for the sake of convenience, is represented by $\phi(\Delta)$, giving the relations

$$y = \phi(\Delta); \quad \phi(\Delta) = \omega e^{-\pi\omega^2 \frac{\Delta^2}{k^2}}. \quad (10)$$

31. The Precision Constant. — The curves in Fig. 4 were plotted, to the same scale, from data computed by equation (9). The constant ω was taken twice as great for the curve *A* as for the curve *B*, and in both cases values of y were computed for successive integral values of the ratio $\frac{\Delta}{k}$. The maximum ordinate of each of these curves corresponds to the zero value of Δ and is equal to the value of ω used in computing the y 's. The curve *A*, corresponding to the larger value of ω , approaches the horizontal axis much more rapidly than the curve *B*.

Obviously, the constant ω determines both the maximum ordinate and the slope of the probability curve. But we have seen that these characteristics are proportional to the precision of the measurements that determine the system of errors represented. Hence ω characterizes the system of errors considered and is proportional to the precision of the corresponding measurements. Some writers have called it the precision measure, but, as it depends only on the accidental errors and takes no account of the accuracy with which constant errors are avoided or corrected, it does not give a complete statement of the pre-

cision. Consequently the term "precision measure" will be reserved for a function to be discussed later, and ω will be called the *precision constant* in the following pages.

When Δ is taken equal to zero in equation (9), y is equal to ω . Hence the precision of measurements, so far as it depends upon accidental errors, is proportional to the probability for the occurrence of zero error in the corresponding system of errors. In this connection, it should be borne in mind that the system of errors includes all of the errors that would have been found with an infinite number of observations, and that it cannot be restricted to the errors of the actual measurements for the purpose of computing ω directly. Indirect methods for computing ω from given observations will be discussed later.

32. Discussion of the Probability Function. — Inspection of the curves in Fig. 4, in connection with equation (9), is sufficient to show that the probability function is in agreement with the first two axioms. Since y is an even function of Δ , positive and negative errors of the same magnitude are equally probable, and consequently equally numerous in an extended series of measurements. Hence the first axiom is fulfilled. Since Δ enters the function only in the negative exponent, the probability for the occurrence of an error decreases very rapidly as its magnitude increases either positively or negatively. Hence small errors are much more likely to occur than large ones and the second axiom is fulfilled.

Since the function $\phi(\Delta)$ is continuous for values of Δ ranging from minus infinity to plus infinity, it is apparently at variance with the third axiom. For, if all of the errors lie between definite finite limits $-L$ and $+L$, $\phi(\Delta)$ should be continuous while Δ lies between these limits and equal to zero for all values of Δ outside of them. But we have no means of fixing the limits $+L$ and $-L$, in any given case; and we note that $\phi(\Delta)$ becomes very small for moderately large values of Δ . Hence, whatever the true value of L may be, the error involved in extending the limits to $-\infty$ and $+\infty$ is infinitesimal. Consequently, $\phi(\Delta)$ is in substantial agreement with the third axiom provided it leads to the conclusion that all possible errors lie between the limits $-\infty$ and $+\infty$. This will be the case if it gives unity for the probability that a single error, chosen at random, lies between $-\infty$ and $+\infty$. For, if all of the errors lie between these limits, the probability considered is a certainty and hence is represented by unity.

33. **The Probability Integral.** — The accidental errors, corresponding to actual measurements, may be arranged in groups according to their magnitude in the same manner that the residuals were arranged in article twenty-eight. When this is done the errors in succeeding groups differ in magnitude by an amount equal to the unit error k , since k is the least difference that can be determined with the instruments used in making the observations. Hence, if Δ_p is the common magnitude of the errors in the p th group,

$$\Delta_{(p+1)} - \Delta_p = \Delta_{(p+2)} - \Delta_{(p+1)} = \dots = \Delta_{(p+q)} - \Delta_{(p+q-1)} = k,$$

or, expressing the same relation in different form,

$$\frac{\Delta_p}{k} = p + \frac{\alpha}{k}; \quad \frac{\Delta_{(p+1)}}{k} = (p+1) + \frac{\alpha}{k}; \quad \dots \quad \frac{\Delta_{(p+q)}}{k} = (p+q) + \frac{\alpha}{k}, \quad (i)$$

where α is an indeterminate quantity that enters each of the equations because we do not know the actual magnitude of the Δ 's.

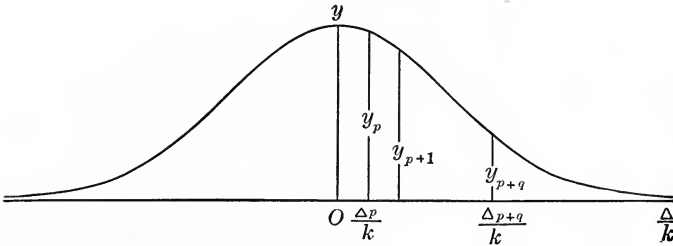

FIG. 5.

Let the probability curve in Fig. 5 represent the system of errors to which the errors of the actual measurements belong. Then the ordinates $y_p, y_{(p+1)}, y_{(p+2)}, \dots, y_{(p+q)}$ represent the probabilities of the errors $\Delta_p, \Delta_{(p+1)}, \dots, \Delta_{(p+q)}$ respectively. Since the errors of the actual measurements satisfy the relation (i), none of them correspond to points of the curve lying between the ordinates $y_p, y_{(p+1)}, \dots, y_{(p+q)}$. Hence, in virtue of equation (6), article twenty-three, if we choose one of the measurements at random the probability that the magnitude of its error lies between Δ_p and $\Delta_{(p+q)}$ is

$$y_p^q = y_{(p+1)} + y_{(p+2)} + \dots + y_{(p+q)}.$$

Multiplying and dividing the second member by q ,

$$\begin{aligned} y_p^q &= \frac{y_{(p+1)} + y_{(p+2)} + \cdots + y_{(p+q)}}{q} q \\ &= \bar{y}_{pq} \cdot q, \end{aligned} \quad (\text{ii})$$

where \bar{y}_{pq} is written for the mean of the ordinates between y_p and $y_{(p+q)}$. From equation (i)

$$\frac{\Delta_{(p+q)}}{k} - \frac{\Delta_p}{k} = \frac{\Delta_{(p+q)} - \Delta_p}{k} = q.$$

Hence,

$$y_p^q = \bar{y}_{pq} \frac{\Delta_{(p+q)} - \Delta_p}{k}. \quad (\text{iii})$$

In the limit, when we consider the errors of an infinite number of measurements made with infinitely sensitive instruments, every point of the curve represents the probability of one of the errors of the system. Consequently, for any finite value of q , the interval between the ordinates y_p and $y_{(p+q)}$ is infinitesimal, and all of the ordinates between these limits may be considered equal. Hence, in the limit,

$$\Delta_{(p+q)} - \Delta_p = d\Delta, \quad \bar{y}_{pq} = y_\Delta = \phi(\Delta),$$

and (iii) reduces to

$$y_\Delta^{\Delta+d\Delta} = \phi(\Delta) \frac{d\Delta}{k}, \quad (11)$$

where $y_\Delta^{\Delta+d\Delta}$ represents the probability that the magnitude of a single error, chosen at random, is between Δ and $\Delta + d\Delta$.

By applying the usual reasoning of the integral calculus, it is evident that the expression

$$y_a^b = \frac{1}{k} \int_a^b \phi(\Delta) d\Delta, \quad (12)$$

represents the probability that the magnitude of an error, chosen at random, lies between the limits a and b . The integral in this expression also represents the area under the probability curve between the ordinates at $\frac{a}{k}$ and $\frac{b}{k}$. Consequently the probability in question is represented graphically by the shaded area in Fig. 6.

The probability that an error, chosen at random, is numerically less than a given error Δ is equal to the probability that it lies

between the limits $-\Delta$ and $+\Delta$. Hence, if we designate this probability by P_Δ ,

$$\begin{aligned} P_\Delta &= y_{-\Delta}^{+\Delta} = \frac{1}{k} \int_{-\Delta}^{+\Delta} \phi(\Delta) d\Delta, \\ &= \frac{2}{k} \int_0^\Delta \phi(\Delta) d\Delta, \end{aligned}$$

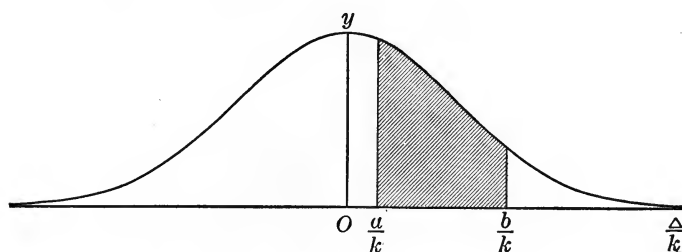

FIG. 6.

since $\phi(\Delta)$ is an even function of Δ . Introducing the complete expression for $\phi(\Delta)$ from equation (10) we obtain

$$P_\Delta = \frac{2\omega}{k} \int_0^\Delta e^{-\pi\omega^2 \frac{\Delta^2}{k^2}} d\Delta$$

For the sake of simplification, put

$$\pi\omega^2 \frac{\Delta^2}{k^2} = t^2,$$

then

$$P_\Delta = \frac{2}{\sqrt{\pi}} \int_0^{\sqrt{\pi}\omega \frac{\Delta}{k}} e^{-t^2} dt = \frac{2}{\sqrt{\pi}} \int_0^t e^{-t^2} dt, \quad (13)$$

which is an entirely general expression for the probability P_Δ , applicable to any system of errors when we know the corresponding values of the constants ω and k . A series of numerical values of the right-hand member of (13), corresponding to successive values of the argument t , is given in Table XI, at the end of this volume. Obviously, this table may be used in computing the probability P_Δ corresponding to any system of errors, since the characteristic constants ω and k appear only in the limit of the integral.

Whatever the values of the constants ω and k , the limit $\sqrt{\pi}\omega \frac{\Delta}{k}$

becomes infinite when Δ is equal to infinity. Hence, in every system of errors,

$$P_{\infty} = \frac{2}{\sqrt{\pi}} \int_0^{\infty} e^{-t^2} dt = 1, \quad (13a)$$

where the numerical value is that given in Table XI, for the limit t equals infinity. Consequently the probability function $\phi(\Delta)$ leads to the conclusion that all of the errors in any system lie between the limits $-\infty$ and $+\infty$, and, therefore, it fulfills the condition imposed by the third axiom as explained in the last paragraph of article thirty-two.

34. Comparison of Theory and Experience. — Equation (13) may be used to compare the distribution of the residuals actually found in any series of measurements with the theoretical distribution of the accidental errors. If N equally trustworthy measurements of the same magnitude have been made, all of the N corresponding accidental errors belong to the same system, and the probability that the error of a single measurement is numerically less than Δ is given by P_{Δ} in equation (13). Consequently, if N is sufficiently large, we should expect to find

$$N_{\Delta} = NP_{\Delta} \quad (iv)$$

errors less than Δ . For, if we consider only the errors of the actual measurements, the probability that one of them is less than Δ is equal to the ratio of the number less than Δ to the total number. In the same manner, the number less than Δ' should be

$$N_{\Delta'} = NP_{\Delta'}.$$

Hence, the number lying between the limits Δ and Δ' should be

$$N_{\Delta}^{\Delta'} = N_{\Delta'} - N_{\Delta}. \quad (v)$$

These numbers may be computed by equation (13) with the aid of Table XI, when we know N and the value of the expression $\frac{\sqrt{\pi}\omega}{k}$ corresponding to the given measurements. The number, $N_{r'}^{\Delta}$, of residuals lying between the limits r equals Δ and r' equals Δ' may be found by inspecting the series of residuals computed from the given measurements by equation (3), article twenty-two. If N is large and the errors of the given measurements satisfy the theory we have developed, the numbers $N_{\Delta}^{\Delta'}$ and $N_{r'}^{\Delta}$ should

be very nearly equal, since in an extended series of measurements the residuals are very nearly equal to the accidental errors.

The following illustration, taken from Chauvenet's "Manual of Spherical and Practical Astronomy," is based on 470 observations of the right ascension of *Sirius* and *Altair*, by Bradley. The errors of these measurements belong to a system characterized by a particular value of the ratio $\frac{\omega}{k}$ that has been computed, by a method to be described later (articles thirty-eight and forty-two), and gives the relation

$$\frac{\sqrt{\pi\omega}}{k} = 1.8086.$$

Consequently, to find the theoretical value of P_{Δ} , corresponding to any limit Δ , we take t equal to 1.8086Δ in equation (13) and find the corresponding value of the integral by interpolation from Table XI.

The third column of the following table gives the values of P_{Δ} corresponding to the chosen values of Δ in the first column and the computed values of t in the second column. The fourth column gives the corresponding values of N_{Δ} computed by equation (iv), taking N equal to 470. The sixth column, computed by equation (v), gives the number, N_{Δ}' , of errors that should lie between the limits Δ and Δ' given in the fifth. The seventh column gives the number of residuals actually found between the same limits.

Δ	t	P_{Δ}	N_{Δ}	Limits $\Delta \quad \Delta'$	N_{Δ}'	N_r'
"	"	"	"	" "	"	"
0.1	0.1809	0.2019	95	0.0-0.1	95	94
0.2	0.3617	0.3910	184	0.1-0.2	89	88
0.3	0.5426	0.5571	262	0.2-0.3	78	78
0.4	0.7234	0.6937	326	0.3-0.4	64	58
0.5	0.9043	0.7990	376	0.4-0.5	50	51
0.6	1.0852	0.8751	411	0.5-0.6	35	36
0.7	1.2660	0.9266	436	0.6-0.7	25	26
0.8	1.4469	0.9593	451	0.7-0.8	15	14
0.9	1.6277	0.9787	460	0.8-0.9	9	10
1.0	1.8086	0.9895	465	0.9-1.0	5	7
∞	∞	1.0000	470	1.0- ∞	5	8

Comparison of the numbers in the last two columns shows very good agreement between theory, represented by N_{Δ}' , and expe-

rience, represented by N_r' , when we remember that the theory assumes an infinite number of observations and that the series considered is finite. Numerous comparisons of this nature have been made, and substantial agreement has been found in all cases in which a sufficient number of independent observations have been considered. In general, the differences between N_{Δ}' and N_r' decrease in relative magnitude as the number of observations is increased.

35. The Arithmetical Mean. — In article twenty-four it was pointed out, as one of the fundamental principles of the theory of errors, that the arithmetical mean of a number of equally trustworthy direct measurements on the same magnitude is the most probable value that we can assign to the numeric of the measured magnitude. In order to show that the probability function $\phi(\Delta)$ leads to the same conclusion, let a_1, a_2, \dots, a_N represent the given measurements, and let x represent the unknown numeric of the measured magnitude. If the actual value of this numeric is X , the true accidental errors of the given measurements are

$$\Delta_1 = a_1 - X, \quad \Delta_2 = a_2 - X, \quad \dots \quad \Delta_N = a_N - X, \quad (2)$$

and all of them belong to the same system, characterized by a particular value of the precision constant ω . The probability that one of the errors of this system, chosen at random, is equal to an arbitrary magnitude Δ_p is given by the relation

$$y_p = \omega e^{-\pi\omega^2 \frac{\Delta_p^2}{k^2}} = \phi(\Delta_p).$$

Since we cannot determine the true value X , the most probable value that we can assign to x is that which gives a maximum probability that N errors of the system are equal to the N residuals

$$r_1 = a_1 - x, \quad r_2 = a_2 - x, \quad \dots \quad r_N = a_N - x. \quad (3)$$

This is equivalent to determining x , so that the residuals are as nearly as possible equal to the accidental errors.

If y_1, y_2, \dots, y_N represent the probabilities that a single error of the system, chosen at random, is equal to r_1, r_2, \dots, r_N respectively,

$$y_1 = \phi(r_1), \quad y_2 = \phi(r_2), \quad \dots \quad y_N = \phi(r_N).$$

Hence, if P is the probability that N of the errors chosen together

are equal to r_1, r_2, \dots, r_N respectively, we have, by equation (7), article twenty-three,

$$P = y_1 \times y_2 \times \dots \times y_N \\ = \omega^N e^{-\pi \frac{\omega^2}{k^2} (r_1^2 + r_2^2 + \dots + r_N^2)}.$$

Since the exponent in this expression is negative and $\frac{\pi\omega^2}{k^2}$ is constant, the maximum value of P will correspond to the minimum value of $(r_1^2 + r_2^2 + \dots + r_N^2)$. Hence the most probable value of x is that which renders the sum of the squares of the residuals a minimum.

In the present case, the r 's are functions of a single independent variable x . Consequently the sum of the squares of the r 's will be a minimum when x satisfies the condition

$$\frac{\partial}{\partial x} (r_1^2 + r_2^2 + \dots + r_N^2) = 0.$$

Substituting the expression for the r 's in terms of x from equation (3) this becomes

$$\frac{\partial}{\partial x} \left\{ (a_1 - x)^2 + (a_2 - x)^2 + \dots + (a_N - x)^2 \right\} = 0.$$

Hence, $(a_1 - x) + (a_2 - x) + \dots + (a_N - x) = 0$, (14)

and
$$x = \frac{a_1 + a_2 + \dots + a_N}{N}$$

Consequently, if we take x equal to the arithmetical mean of the a 's in (3), the sum of the squares of the computed r 's is less than for any other value of x . Hence the probability P that N errors of the system are equal to the N residuals is a maximum, and the arithmetical mean is the most probable value that we can assign to the numeric X on the basis of the given measurements.

Equation (14) shows that the sum of the residuals, obtained by subtracting the arithmetical mean from each of the given measurements, is equal to zero. This is a characteristic property of the arithmetical mean and serves as a useful check on the computation of the residuals.

The argument of the present article should be regarded as a justification of the probability function $\phi(\Delta)$ rather than as a proof of the principle of the arithmetical mean. As pointed out above, this principle is sufficiently established on *a priori* grounds and by common consent.

CHAPTER V.

CHARACTERISTIC ERRORS.

SEVERAL different derived errors have been used as a measure of the relative accuracy of different series of measurements. Such errors are called *characteristic errors* of the system, and they decrease in magnitude as the accuracy of the measurements, on which they depend, increases. Those most commonly employed are the average error A , the mean error M , and the probable error E , any one of which may be used as a measure on the relative accuracy of a single observation.

36. The Average Error. — The average error A of a single observation is the arithmetical mean of all of the individual errors of the system taken without regard to sign. That is, all of the errors are taken as positive in forming the average. Hence, if N is the total number of errors,

$$A = \frac{\Delta_1 + \Delta_2 + \cdots + \Delta_N}{N} = \frac{[\overline{\Delta}]}{N}, \quad (15)$$

where the square bracket [] is used as a sign of summation, and the $\overline{}$ over the Δ indicates that, in taking the sum, all of the Δ 's are to be considered positive.

In accordance with the usual practice of writers on the theory of errors, the square bracket [] will be used as a sign of summation, in the following pages, in place of the customary sign Σ . This notation is adopted because it saves space and renders complicated expressions more explicit.

In equation (15) all of the errors of the system are supposed to be included in the summation. Hence, both $[\overline{\Delta}]$ and N are infinite and the equation cannot be applied to find A directly from the errors of a limited number of measurements. Consequently we will proceed to show how the average error can be derived from the probability function, and to find its relation to the precision constant ω . A little later we shall see how A can be computed directly from the residuals corresponding to a limited number of measurements.

If y_d is the probability that the magnitude of a single error, chosen at random, lies between Δ and $\Delta + d\Delta$, and n_d is the number of errors between these limits,

$$y_d = \frac{n_d}{N},$$

and consequently

$$\begin{aligned} n_d &= Ny_d \\ &= N\phi(\Delta) \frac{d\Delta}{k} \end{aligned} \quad (16)$$

in virtue of equation (11), article thirty-three, where Δ represents the mean magnitude of the errors lying between Δ and $\Delta + d\Delta$. Hence, the sum of the errors between these limits is

$$[\Delta]_d = \Delta n_d = \frac{N}{k} \Delta \phi(\Delta) d\Delta,$$

and the sum of the errors between $\Delta = a$ and $\Delta = b$ is

$$[\Delta]_a^b = \frac{N}{k} \int_a^b \Delta \phi(\Delta) d\Delta.$$

Substituting the complete expression for $\phi(\Delta)$ from equation (10) this becomes

$$[\Delta]_a^b = \frac{N\omega}{k} \int_a^b \Delta e^{-\pi\omega^2 \frac{\Delta^2}{k^2}} d\Delta.$$

Hence, the sum of the positive errors of the system is

$$\frac{N\omega}{k} \int_0^{\infty} \Delta e^{-\pi\omega^2 \frac{\Delta^2}{k^2}} d\Delta,$$

and the sum of the negative errors is

$$-\frac{N\omega}{k} \int_{-\infty}^0 \Delta e^{-\pi\omega^2 \frac{\Delta^2}{k^2}} d\Delta.$$

These two integrals are obviously equal in magnitude and opposite in sign. Consequently the sum of all of the errors of the system taken without regard to sign is

$$\begin{aligned} [\bar{\Delta}] &= \frac{2N\omega}{k} \int_0^{\infty} \Delta e^{-\pi\omega^2 \frac{\Delta^2}{k^2}} d\Delta \\ &= -\frac{Nk}{\pi\omega} \left[e^{-\pi\omega^2 \frac{\Delta^2}{k^2}} \right]_0^{\infty} \\ &= \frac{Nk}{\pi\omega}. \end{aligned} \quad (17)$$

Hence from equation (15),

$$A = \frac{[\bar{\Delta}]}{N} = \frac{k}{\pi\omega}, \quad (18)$$

and introducing the numerical value of π ,

$$A = 0.3183 \frac{k}{\omega}. \quad (19)$$

37. The Mean Error. — The mean error M of a single measurement in a given series is the square root of the mean of the squares of the errors in the system determined by the given measurements. Expressed mathematically

$$M^2 = \frac{\Delta_1^2 + \Delta_2^2 + \dots + \Delta_N^2}{N} = \frac{[\Delta^2]}{N}. \quad (20)$$

This equation includes all of the errors that belong to the given system. Hence, as pointed out in article thirty-six, in regard to equation (15), it cannot be applied directly to a limited series of measurements.

By equation (16) the number of errors with magnitudes between the limits Δ and $\Delta + d\Delta$ is equal to $\frac{N\phi(\Delta) d\Delta}{k}$. Consequently the sum of the squares of the errors between these limits is equal to $\frac{N\Delta^2\phi(\Delta) d\Delta}{k}$. Hence, by reasoning similar to that employed in the last article,

$$\begin{aligned} [\Delta^2] &= \frac{N\omega}{k} \int_{-\infty}^{+\infty} \Delta^2 e^{-\pi\omega^2 \frac{\Delta^2}{k^2}} d\Delta \\ &= \frac{2N\omega}{k} \int_0^{\infty} \Delta^2 e^{-\pi\omega^2 \frac{\Delta^2}{k^2}} d\Delta, \end{aligned} \quad (21)$$

since the integrand is an even function of Δ . Integrating by parts,

$$\begin{aligned} [\Delta^2] &= -\frac{Nk}{\pi\omega} \Delta e^{-\pi\omega^2 \frac{\Delta^2}{k^2}} \Big|_0^{\infty} \\ &\quad + \frac{Nk}{\pi\omega} \int_0^{\infty} e^{-\pi\omega^2 \frac{\Delta^2}{k^2}} d\Delta. \end{aligned}$$

The first term of the second member of this equation reduces to

zero when the limits are applied. Putting t^2 for $\frac{\pi\omega^2\Delta^2}{k^2}$ in the second term,

$$[\Delta^2] = \frac{Nk^2}{\pi^{\frac{1}{2}}\omega^2} \int_0^\infty e^{-t^2} dt = \frac{Nk^2}{2\pi\omega^2}, \quad (22)$$

in virtue of equation (13a). Hence,

$$M^2 = \frac{[\Delta^2]}{N} = \frac{k^2}{2\pi\omega^2}$$

and

$$\left. \begin{aligned} M &= \frac{1}{\sqrt{2\pi}} \cdot \frac{k}{\omega}, \\ &= 0.3989 \frac{k}{\omega}. \end{aligned} \right\} \quad (23)$$

38. The Probable Error. — The probable error E of a single measurement is a magnitude such that a single error, chosen at random from the given system, is as likely to be numerically greater than E as less than E . In other words, the probability that the error of a single measurement is greater than E is equal to the probability that it is less than E . Hence, in any extended series of measurements, one-half of the errors are less than E and one-half of them are greater than E .

The name "probable error," though sanctioned by universal usage, is unfortunate; and the student cannot be too strongly cautioned against a common misinterpretation of its meaning. The probable error is NOT the most probable magnitude of the error of a single measurement and it DOES NOT determine the limits within which the true numeric of the measured magnitude may be expected to lie. Thus, if x represents the measured numeric of a given magnitude Q and E is the probable error of x , it is customary to express the result of the measurement in the form

$$Q = x \pm E.$$

This does not signify that the true numeric of Q lies between the limits $x - E$ and $x + E$, neither does it imply that x is probably in error by the amount E . It means that the numeric of Q is as likely to lie between the above limits as outside of them. If a new measurement is made by the same method and with equal care, the probability that it will differ from x by less than E is equal to the probability that it will differ by more than E .

In article thirty-three it was pointed out that the probability that an error, chosen at random from a given system, lies between the limits $\Delta = a$ and $\Delta = b$ is represented by the area under the probability curve between the ordinates corresponding to the limiting values of Δ . Hence, the probability that the error of a single measurement is numerically less than E may be represented by the area under the probability curve between the ordinates y_{-E} and y_{+E} , in Fig. 7, and the probability that it is greater than E by the sum of the areas outside of these ordinates. Since these two

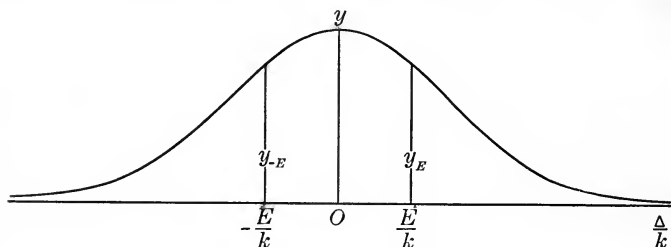

FIG. 7.

probabilities are equal, by definition, the ordinates corresponding to the probable error bisect the areas under the two branches of the probability curve.

Since the probability that the error of a single measurement is less than E is equal to the probability that it is greater than E and the probability that it is less than infinity is unity, the probability that it is less than E is one-half. Consequently, putting Δ equal to E in equation (13), article thirty-three,

$$P_E = \frac{2}{\sqrt{\pi}} \int_0^{\sqrt{\pi\omega} \frac{E}{k}} e^{-t^2} dt = \frac{1}{2}. \quad (24)$$

From Table XI,

$$P_\Delta = 0.49375 \text{ for the limit } t = 0.47,$$

$$P_\Delta = 0.50275 \text{ for the limit } t = 0.48,$$

and by interpolation,

$$P_E = 0.50000 \text{ for the limit } t = 0.47694.$$

Hence, equation (24) is satisfied when

$$t = \sqrt{\pi\omega} \frac{E}{k} = 0.47694,$$

and we have

$$\left. \begin{aligned} E &= \frac{0.47694}{\sqrt{\pi}} \cdot \frac{k}{\omega} \\ &= 0.2691 \frac{k}{\omega} \end{aligned} \right\} \quad (25)$$

39. **Relations between the Characteristic Errors.** — Eliminating $\frac{k}{\omega}$ from equations (18), (23), and (25), taken two at a time, we obtain the relations

$$\left. \begin{aligned} M &= \sqrt{\frac{\pi}{2}} A = 1.253 \cdot A, \\ E &= 0.4769 \cdot \sqrt{\pi} \cdot A = 0.8453 \cdot A, \\ E &= 0.4769 \cdot \sqrt{2} \cdot M = 0.6745 \cdot M, \end{aligned} \right\} \quad (26)$$

which express the relative magnitudes of the average, mean, and probable errors. These relations are universally adopted in com-

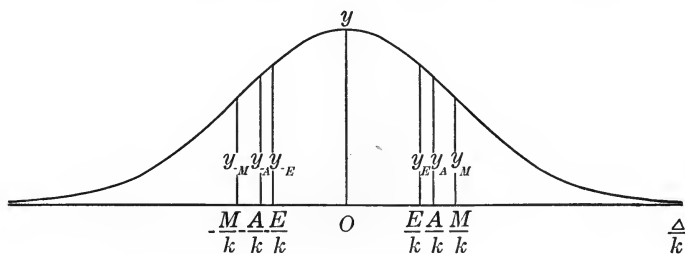

FIG. 8.

puting the precision of given series of measurements, and they should be firmly fixed in mind.

The three equations from which the relations (26) are derived may be put in the form

$$\left. \begin{aligned} \frac{A}{k} &= \frac{0.3183}{\omega}, \\ \frac{M}{k} &= \frac{0.3989}{\omega}, \\ \frac{E}{k} &= \frac{0.2691}{\omega}. \end{aligned} \right\} \quad (27)$$

The probability curve in Fig. 8 represents the distribution of the errors in a system characterized by a particular value of ω ,

determined by a given series of measurements. The ordinates y_A , y_M , and y_E correspond to the abscissæ $\frac{A}{k}$, $\frac{M}{k}$, and $\frac{E}{k}$, computed by the above equations. Consequently, y_A represents the probability that the error of a single measurement is equal to $+A$, y_M the probability that it is equal to $+M$, and y_E the probability that it is equal to $+E$. In like manner y_{-A} , y_{-M} , and y_{-E} represent the respective probabilities for the occurrence of errors equal to $-A$, $-M$, and $-E$.

A curve of this type can be constructed to correspond to any given series of measurements, and in all cases the relative location of the ordinates y_A , y_M , and y_E will be the same. It was pointed out in the last article that the ordinates y_E and y_{-E} bisect the areas under the two branches of the curve. Consequently, in an extended series of measurements, somewhat more than one-half of the errors will be less than either the average or the mean error. Moreover, it is obvious from Fig. 8 that an error equal to E is somewhat more likely to occur than one equal to either A or M .

Since each of the characteristic errors A , M , and E , bears a constant relation to the precision constant ω , any one of them might be used as a measure of the precision of a single measurement in a given series, so far as this depends on accidental errors. The probable error is more commonly employed for this purpose on account of its median position in the system of errors determined by the given measurements.

It is interesting to observe that the ordinate y_M corresponds to a point of inflection in the probability curve. By the ordinary method of the calculus we know that this curve has a point of inflection corresponding to the abscissa that satisfies the relation

$$\frac{\partial^2 y}{\partial \Delta^2} = 0.$$

Substituting the complete expression for y

$$\frac{\partial^2}{\partial \Delta^2} \omega e^{-\pi \omega^2 \frac{\Delta^2}{k^2}} = 0,$$

$$2\pi \omega^2 \frac{\Delta^2}{k^2} - 1 = 0.$$

Hence,

$$\frac{\Delta}{k} = \pm \frac{1}{\sqrt{2\pi}} \cdot \frac{1}{\omega}$$

is the abscissa of the point of inflection. Comparing this with equation (23) we see that

$$\pm \frac{\Delta}{k} = \pm \frac{M}{k},$$

and consequently that the ordinates y_M and y_{-M} meet the probability curve at points of inflection.

40. Characteristic Errors of the Arithmetical Mean.—Equation (23) may be put in the form

$$\pi \frac{\omega^2}{k^2} = \frac{1}{2M^2},$$

where M is the mean error of a single measurement in a series corresponding to the unit error k and the precision constant ω . Consequently the probability function,

$$y = \omega e^{-\pi \omega^2 \frac{\Delta^2}{k^2}},$$

corresponding to the same series may be put in the form

$$y = \omega e^{-\frac{\Delta^2}{2M^2}}. \quad (i)$$

If $\Delta_1, \Delta_2, \dots, \Delta_N$ are the accidental errors of N direct measurements in the same series, the probability P that they all occur in a system characterized by the mean error M is equal to the product of the probabilities for the occurrence of the individual errors in that system. Hence,

$$P = \omega^N e^{-\frac{1}{2M^2}(\Delta_1^2 + \Delta_2^2 + \dots + \Delta_N^2)}. \quad (ii)$$

If the individual measurements are represented by a_1, a_2, \dots, a_N , and the true numeric of the measured quantity is X ,

$$\Delta_1 = a_1 - X; \quad \Delta_2 = a_2 - X; \quad \dots \quad \Delta_N = a_N - X,$$

and, if x is the arithmetical mean of the measurements, the corresponding residuals are

$$r_1 = a_1 - x; \quad r_2 = a_2 - x; \quad \dots \quad r_N = a_N - x.$$

Consequently, if the error of the arithmetical mean is δ ,

$$X - x = \delta,$$

and

$$\Delta_1 = r_1 - \delta; \quad \Delta_2 = r_2 - \delta; \quad \dots \quad \Delta_N = r_N - \delta.$$

Squaring and adding,

$$\begin{aligned} [\Delta^2] &= [r^2] - 2\delta[r] + N\delta^2, \\ &= [r^2] + N\delta^2, \end{aligned} \quad (28)$$

since $[r]$ is equal to zero in virtue of equation (14), article thirty-five. When this value of $[\Delta^2]$ is substituted in (ii), the resulting value of P is the probability that the arithmetical mean is in error by an amount δ . For, as we have seen in article thirty-five, the minimum value of $[r^2]$ occurs when x is taken equal to the arithmetical mean. Consequently, P is a maximum when δ is equal to zero and decreases in accordance with the probability function as δ increases either positively or negatively.

We do not know the exact value of either X or δ ; but, if y_a is the probability that the error of the arithmetical mean is equal to an arbitrary magnitude δ , the foregoing reasoning leads to the relation

$$y_a = \omega^N e^{-\frac{[r^2] + N\delta^2}{2M^2}},$$

$$= \omega^N e^{-\frac{[r^2]}{2M^2}} e^{-\frac{N\delta^2}{2M^2}}. \quad (\text{iii})$$

But the arithmetical mean is equivalent to a single measurement in a series of much greater precision than that of the given measurements. Hence, if ω_a is the precision constant corresponding to this hypothetical series and M_a is the mean error of the arithmetical mean, we have by analogy with (i)

$$y_a = \omega_a e^{-\frac{\delta^2}{2M_a^2}}. \quad (\text{iv})$$

Equations (iii) and (iv) are two expressions for the same probability and should give equal values to y_a whatever the assumed value of δ . This is possible only when

$$\omega_a = \omega^N e^{-\frac{[r^2]}{2M^2}},$$

and

$$\frac{1}{2M_a^2} = \frac{N}{2M^2}.$$

Hence,

$$M_a = \frac{M}{\sqrt{N}}.$$

Consequently, the mean error of the arithmetical mean is equal to the mean error of a single measurement divided by the square root of the number of measurements.

Since the average, mean, and probable errors of a single measurement are connected by the relations (26), the corresponding

errors of the arithmetical mean, distinguished by the subscript a , are given by the relations

$$A_a = \frac{A}{\sqrt{N}}; \quad M_a = \frac{M}{\sqrt{N}}; \quad E_a = \frac{E}{\sqrt{N}}. \quad (29)$$

41. Practical Computation of Characteristic Errors. — As pointed out in article thirty-seven, the square of the mean error M is the limiting value of the ratio $\frac{[\Delta^2]}{N}$ when both members become infinite, i.e., when all of the errors of the given system are considered. But the errors of the actual measurements fall into groups, as explained in article thirty-three, and the errors in succeeding groups differ in magnitude by a constant amount k , depending on the nature of the instruments used in making the observations. Consequently, the ordinates, of the probability curve, corresponding to these errors are uniformly distributed along the horizontal axis. Hence, if we include in $[\Delta^2]$ only the errors of the actual measurements, the limiting value of the ratio $\frac{[\Delta^2]}{N}$ when N is indefinitely increased will be nearly the same as if all of the errors of the system were included. Since the ratio approaches its limit very rapidly as N increases, the value of M can be determined, with sufficient precision for most practical purposes, from a somewhat limited series of measurements.

If we knew the true accidental errors, the mean error could be computed at once from the relation

$$M = \sqrt{\frac{[\Delta^2]}{N}}, \quad (v)$$

and, since the residuals are nearly equal to the accidental errors when N is very large, an approximate value can be obtained by using the r 's in place of the Δ 's. A better approximation can be obtained if we take account of the difference between the Δ 's and the r 's. From equation (28)

$$[\Delta^2] = [r^2] + N\delta^2, \quad (vi)$$

where δ is the unknown error of the arithmetical mean. Probably the best approximation we can make to the true value of δ is to set it equal to the mean error of the arithmetical mean. Hence, from the second of equations (29)

$$N\delta^2 = NM_a^2 = M^2,$$

and from (v)

$$[\Delta^2] = NM^2.$$

Consequently, (vi) becomes

$$NM^2 = [r^2] + M^2,$$

and we have

$$M = \sqrt{\frac{[r^2]}{N-1}}. \quad (30)$$

Thus the square of the mean error of a single measurement is equal to the sum of the squares of the residuals divided by the number of measurements less one.

Combining (30) with the third of equations (26), article thirty-nine, we obtain the expression

$$E = 0.6745 \sqrt{\frac{[r^2]}{N-1}} \quad (31)$$

for the probable error of a single measurement. Hence, by equations (29), the mean error M_a and the probable error E_a of the arithmetical mean are given by the relations

$$M_a = \sqrt{\frac{[r^2]}{N(N-1)}} \quad \text{and} \quad E_a = 0.6745 \sqrt{\frac{[r^2]}{N(N-1)}}. \quad (32)$$

When the number of measurements is large, the computation of the probable errors E and E_a by the above formulæ is somewhat tedious, owing to the necessity of finding the square of each of the residuals. In such cases a sufficiently close approximation for practical purposes can be derived from the average error A with the aid of equations (26). The first of these equations may be written in the form

$$\frac{[\Delta^2]}{N} = \frac{\pi}{2} \frac{[\Delta]^2}{N^2}.$$

If we assume that the distribution of the residuals is the same as that of the true accidental errors, a condition that is accurately fulfilled when N is very large, we can put

$$\frac{[r^2]}{N} = \frac{\pi}{2} \frac{[\bar{r}]^2}{N^2}.$$

Consequently,

$$\frac{[\Delta^2]}{[r^2]} = \frac{[\Delta]^2}{[\bar{r}]^2}.$$

When the mean error M is expressed in terms of the Δ 's, equation (30) becomes

$$\frac{[\Delta^2]}{N} = \frac{[r^2]}{N-1},$$

or

$$\frac{[\Delta^2]}{[r^2]} = \frac{N}{N-1} = \frac{[\Delta]^2}{[\bar{r}]^2}.$$

Consequently

$$\frac{[\Delta]^2}{N^2} = \frac{[\bar{r}]^2}{N(N-1)},$$

and, since this ratio is equal to A^2 , we have

$$A = \frac{[\bar{r}]}{\sqrt{N(N-1)}} \quad \text{and} \quad A_a = \frac{[\bar{r}]}{N\sqrt{N-1}}. \quad (33)$$

Combining this result with the second of equations (26) and the third of (29), we obtain

$$E = 0.8453 \frac{[\bar{r}]}{\sqrt{N(N-1)}}; \quad E_a = 0.8453 \frac{[\bar{r}]}{N\sqrt{N-1}}. \quad (34)$$

The above formulæ for computing the characteristic errors from the residuals have been derived on the assumption that the true accidental errors and the residuals follow the same law of distribution. This is strictly true only when the number of measurements considered is very large. Yet, for lack of a better method, it is customary to apply the foregoing formulæ to the discussion of the errors of limited series of measurements and the results thus obtained are sufficiently accurate for most practical purposes. When the highest attainable precision is sought, the number of observations must be increased to such an extent that the theoretical conditions are fulfilled.

The choice between the formulæ involving the average error A and those depending on the mean error M is determined largely by the number of measurements available and the amount of time that it is worth while to devote to the computations. When the number of measurements is very large, both sets of formulæ lead to the same values for the probable errors E and E_a , and much time is saved by employing those depending on A . For limited series of observations a better approximation to the true values of these errors is obtained by employing the formulæ involving the mean error. In either case the computation may be

facilitated by the use of Tables XIV and XV at the end of this volume. These tables give the values of the functions

$$\frac{0.6745}{\sqrt{N-1}}, \quad \frac{0.6745}{\sqrt{N(N-1)}}, \quad \frac{0.8453}{\sqrt{N(N-1)}}, \quad \text{and} \quad \frac{0.8453}{N\sqrt{N-1}},$$

corresponding to all integral values of N between two and one hundred.

42. Numerical Example. — The following example, representing a series of observations taken for the purpose of calibrating the screw of a micrometer microscope, will serve to illustrate the practical application of the foregoing methods. Twenty independent measurements of the normal distance between two parallel lines, expressed in terms of the divisions of the micrometer head, are given in the first and fourth columns of the following table under a .

a	r	r^2	a	r	r^2
194.7	+0.53	0.2809	194.3	+0.13	0.0169
194.1	-0.07	0.0049	194.3	+0.13	0.0169
194.3	+0.13	0.0169	194.0	-0.17	0.0289
194.0	-0.17	0.0289	194.4	+0.23	0.0529
193.7	-0.47	0.2209	194.5	+0.33	0.1089
194.1	-0.07	0.0049	193.8	-0.37	0.1369
193.9	-0.27	0.0729	193.9	-0.27	0.0729
194.3	+0.13	0.0169	193.9	-0.27	0.0729
194.3	+0.13	0.0169	194.8	+0.63	0.3969
194.4	+0.23	0.0529	193.7	-0.47	0.2209
			194.17	5.20	1.8420
			x	$[\bar{r}]$	$[r^2]$

Since the observations are independent and equally trustworthy, the most probable value that we can assign to the numeric of the measured magnitude is the arithmetical mean x ; and we find that x is equal to 194.17 micrometer divisions. Subtracting 194.17 from each of the given observations we obtain the residuals in the columns under r . The algebraic sum of these residuals is equal to zero as it should be, owing to the properties of the arithmetical mean. The sum without regard to sign, $[\bar{r}]$, is equal to 5.20. Squaring each of the residuals gives the numbers in the columns under r^2 and adding these figures gives 1.8920 for the sum of the squares of the residual $[r^2]$.

Taking N equal to twenty, in formulæ (33) and (34), we find the average and probable errors

$$A = \frac{[\bar{r}]}{\sqrt{N(N-1)}} = \pm 0.267; \quad A_a = \frac{[\bar{r}]}{N\sqrt{N-1}} = \pm 0.0596,$$

$$E = 0.8453 \frac{[\bar{r}]}{\sqrt{N(N-1)}} = \pm 0.226; \quad E_a = 0.8453 \frac{[\bar{r}]}{N\sqrt{N-1}} = \pm 0.0504,$$

where the numerical results are written with the indefinite sign \pm since the corresponding errors are as likely to be positive as negative.

When formulæ (30), (31), and (32) are employed we obtain the mean errors,

$$M = \sqrt{\frac{[r^2]}{N-1}} = \pm 0.311; \quad M_a = \sqrt{\frac{[r^2]}{N(N-1)}} = \pm 0.0696,$$

and the probable errors

$$E = 0.6745 \sqrt{\frac{[r^2]}{N-1}} = \pm 0.210;$$

$$E_a = 0.6745 \sqrt{\frac{[r^2]}{N(N-1)}} = \pm 0.047.$$

The values of the probable errors E and E_a , computed by the two methods, agree as closely as could be expected with so small a number of observations. Probably the values ± 0.210 and ± 0.047 , computed from the mean errors M and M_a , are the more accurate, but those derived from the average errors A and A_a are sufficiently exact for most practical purposes. An inspection of the column of residuals is sufficient to show that eleven of them are numerically greater, and nine are numerically less than either of the computed values of E . Consequently, both of these values fulfill the fundamental definition of the probable error of a single measurement as nearly as we ought to expect when only twenty observations are considered.

If we use D to represent the measured distance between the parallel lines, in terms of micrometer divisions, we may write the final result of the measurements in the form

$$D = 194.170 \pm 0.047 \text{ mic. div.}$$

This does not mean that the true value of D lies between the specified limits, but that it is equally likely to lie between these limits or outside of them. Thus, if another and independent series of twenty measurements of the same distance were made

with the same instrument, and with equal care, the chance that the final result would lie between 194.123 and 194.217 is equal to the chance that it would lie outside of these limits.

Equation (25), article thirty-eight, may be written in the form

$$\sqrt{\pi} \frac{\omega}{k} = \frac{0.4769}{E}.$$

Taking E equal to 0.210, we find that

$$\sqrt{\pi} \frac{\omega}{k} = 2.271$$

for the particular system of errors determined by the above measurements. Consequently, the probability for the occurrence of an error less than Δ in this system is, by equation (13), article thirty-three,

$$P_{\Delta} = \frac{2}{\sqrt{\pi}} \int_0^{2.271 \cdot \Delta} e^{-t^2} dt,$$

and, since there are twenty measurements, we should expect to find 20 P_{Δ} errors numerically less than any assigned value of Δ .

The values of P_{Δ} , corresponding to various assigned values of Δ , can be easily computed with the aid of Table XI and applied, as explained in article thirty-four, to compare the theoretical distribution of the accidental errors with that of the residuals given under r in the above table. Such a comparison would have very little significance in the present case, however it resulted, since the number of observations considered is far too small to fulfill the theoretical requirements. But it would show that, even in such extreme cases, the deviations from the law of errors are not greater than might be expected. The actual comparison is left as an exercise for the student.

43. Rules for the Use of Significant Figures. — The fundamental principles underlying the use of significant figures were explained in article fifteen. General rules for their practical application may be stated in terms of the probable error as follows:

All measured quantities should be so expressed that the last recorded significant figure occupies the place corresponding to the second significant figure in the probable error of the quantity considered.

The number of significant figures carried through the compu-

tations should be sufficient to give the final result within one unit in the last place retained and no more.

For practical purposes probable errors should be computed to two significant figures.

The example given in the preceding article will serve to illustrate the application of these rules. The second significant figure in the probable error of the arithmetical mean occupies the third decimal place. Consequently, the final result is carried to three decimal places, notwithstanding the fact that the last place is occupied by a zero. It would obviously be useless to carry out the result farther than this, since the probable error shows that the digit in the second decimal place is equally likely to be in error by more or less than five units. If less significant figures were used, the fifth figure in computed results might be vitiated by more than one unit.

In order to apply the rules to the individual measurements, it is necessary to make a preliminary series of observations, under as nearly as possible the same conditions that will prevail during the final measurements, and compute the probable error of a single observation from the data thus obtained. Then, if possible, all final measurements should be recorded to the second significant figure in this probable error and no farther. It sometimes happens, as in the above example, that the graduation of the measuring instruments used is not sufficiently fine to permit the attainment of the number of significant figures required by the rule. In such cases the observations are recorded to the last attainable figure, or, if possible, the instruments are so modified that they give the required number of figures. Thus, in the example cited, the second significant figure in the probable error of a single measurement is in the second decimal place, but the micrometer can be read only to one-tenth of a division. Hence the individual measurements are recorded to the first instead of the second decimal place. In this case the accuracy attained in making the settings of the instrument was greater than that attained in making the readings, and an observer, with sufficient experience, would be justified in estimating the fractional parts to the nearest hundredth of a division. A better plan would be to provide the micrometer head with a vernier reading to tenths or hundredths of a division. In the opposite case, when the accuracy of setting is less than the attainable accuracy of reading, it is useless to record

the readings beyond the second significant figure in the probable error of a single observation.

For the purpose of computing the residuals, the arithmetical mean should be rounded to such an extent that the majority of the residuals will come out with two significant figures. This greatly reduces the labor of the computations and gives the calculated characteristic errors within one unit in the second significant figure.

CHAPTER VI.

MEASUREMENTS OF UNEQUAL PRECISION.

44. **Weights of Measurements.** — In the preceding chapter we have been dealing with measurements of equal precision, and the results obtained have been derived on the supposition that there was no reason to assume that any one of the observations was better than any other. Under these conditions we have seen that the most probable value that we can assign to the numeric of the measured magnitude is the arithmetical mean of the individual observations. Also, if M and E are the mean and probable errors of a single observation, M_a and E_a the mean and probable errors of the arithmetical mean, and N the number of observations, we have the relations

$$\left. \begin{aligned} E &= 0.6745 M; & E_a &= 0.6745 M_a, \\ M_a &= \frac{M}{\sqrt{N}}; & E_a &= \frac{E}{\sqrt{N}}, \\ N &= \frac{M^2}{M_a^2} = \frac{E^2}{E_a^2}. \end{aligned} \right\} \quad (35)$$

The true numeric X of the measured magnitude cannot be exactly determined from the given observations, but the final result of the measurements may be expressed in the form

$$X = x \pm E_a,$$

which signifies that X is as likely to lie between the specified limits as outside of them.

Now suppose that the results of m independent series of measurements of the same magnitude, made by the same or different methods, are given in the form

$$\begin{aligned} X &= x_1 \pm E_1, \\ X &= x_2 \pm E_2, \\ &\cdot \quad \cdot \quad \cdot \quad \cdot \quad \cdot \\ X &= x_m \pm E_m. \end{aligned}$$

What is the most probable value that can be assigned to X on the basis of these results? Obviously, the arithmetical mean of the x 's will not do in this case, unless the E 's are all equal, since the x 's violate the condition on which the principle of the arithmetical mean is founded. If we knew the individual observations from which each of the x 's were derived, and if the probable error of a single observation was the same in each of the series, the most probable value of X would be given by the arithmetical mean of all of the individual observations. Generally we do not have the original observations, and, when we do, it frequently happens that the probable error of a single observation is different in the different series. Consequently the direct method is seldom applicable.

The E 's may differ on account of differences in the number of observations in the several series, or from the fact that the probable error of a single observation is not the same in all of them, or from both of these causes. Whatever the cause of the difference, it is generally necessary to reduce the given results to a series of equivalent observations having the same probable error before taking the mean. For it is obvious that a result showing a small probable error should count for more, or have greater weight, in determining the value of X than one that corresponds to a large probable error, since the former result has cost more in time and labor than the latter.

The reduction to equivalent observations having the same probable error is accomplished as follows: m numerical quantities w_1, w_2, \dots, w_m , called the weights of the quantities x_1, x_2, \dots, x_m , are determined by the relations

$$w_1 = \frac{E_s^2}{E_1^2}; \quad w_2 = \frac{E_s^2}{E_2^2}; \quad \dots \quad w_m = \frac{E_s^2}{E_m^2}, \quad (36)$$

where E_s is an arbitrary quantity, generally so chosen that all of the w 's are integers, or may be placed equal to the nearest integer without involving an error of more than one or two units in the second significant figure of any of the E 's. In the following pages E_s will be called the probable error of a standard observation. Obviously, the weight of a standard observation is unity on the arbitrary scale adopted in determining the w 's; for, by equations (36),

$$w_s = \frac{E_s^2}{E_s^2} = 1.$$

Such an observation is not assumed to have occurred in any of the series on which the x 's depend, but is arbitrarily chosen as a basis for the computation of the weights of the given results.

By comparing equations (35) and (36), we see that E_1 is equal to the probable error of the arithmetical mean of w_1 standard observations. But it is also the probable error of the given result x_1 . Consequently x_1 is equivalent to the arithmetical mean of w_1 standard observations. Similar reasoning can be applied to the other E 's and in general we have

$$\left. \begin{aligned} x_1 &= \text{mean of } w_1 \text{ standard observations,} \\ x_2 &= \text{mean of } w_2 \text{ standard observations,} \\ &\cdot \quad \cdot \quad \cdot \quad \cdot \quad \cdot \quad \cdot \quad \cdot \quad \cdot \quad \cdot \quad \cdot \\ x_m &= \text{mean of } w_m \text{ standard observations.} \end{aligned} \right\} \quad (i)$$

The weights w_1, w_2, \dots, w_m are numbers that express the relative importance of the given measurements for the determination of the most probable value of the numeric of the measured magnitude. Each weight represents the number of hypothetical standard observations that must be combined to give an arithmetical mean with a probable error equal to that of the given measurement.

45. **The General Mean.** — From equations (i) it is obvious that

$$\begin{aligned} w_1x_1 &= \text{the sum of } w_1 \text{ standard observations,} \\ w_2x_2 &= \text{the sum of } w_2 \text{ standard observations,} \\ &\cdot \quad \cdot \quad \cdot \quad \cdot \quad \cdot \quad \cdot \quad \cdot \quad \cdot \quad \cdot \quad \cdot \\ w_mx_m &= \text{the sum of } w_m \text{ standard observations,} \end{aligned}$$

and, consequently,

$$w_1x_1 + w_2x_2 + \dots + w_mx_m$$

is equal to the sum of $w_1 + w_2 + \dots + w_m$ standard observations. Since the probable error E_s is common to all of the standard observations, they are equally trustworthy and their arithmetical mean is the most probable value that we can assign to the numeric X on the basis of the given data. Representing this value of x_0 we have

$$x_0 = \frac{w_1x_1 + w_2x_2 + \dots + w_mx_m}{w_1 + w_2 + \dots + w_m} \quad (37)$$

The products w_1x_1 , etc., are called weighted observations or meas-

urements, and x_0 is called the general or weighted mean. The weight w_0 of x_0 is obviously given by the relation

$$w_0 = w_1 + w_2 + \dots + w_m, \quad (38)$$

since x_0 is the mean of w_0 standard observations.

Equation (37) for the general mean can be established independently from the law of accidental errors in the following manner: Let $\omega_1, \omega_2, \dots, \omega_m$ represent the precision constants corresponding to the probable errors E_1, E_2, \dots, E_m , and let ω_s be an arbitrary quantity connected with the arbitrary quantity E_s by the relation

$$E_s = 0.2691 \frac{k}{\omega_s}.$$

Then, by equations (25) and (36),

$$w_1 = \frac{\omega_1^2}{\omega_s^2}; \quad w_2 = \frac{\omega_2^2}{\omega_s^2}; \quad \dots \quad w_m = \frac{\omega_m^2}{\omega_s^2}. \quad (39)$$

If x_0 is the most probable value of the numeric X , the residuals corresponding to the given x 's are

$$r_1 = x_1 - x_0; \quad r_2 = x_2 - x_0; \quad \dots \quad r_m = x_m - x_0.$$

The probability that the true accidental error of x_1 is equal to r_1 is

$$\begin{aligned} y_1 &= \omega_1 e^{-\pi \omega_1^2 \frac{r_1^2}{k^2}}, \\ &= \omega_1 e^{-\pi \frac{\omega_s^2}{k^2} w_1 r_1^2}, \end{aligned}$$

in virtue of equations (39). Similarly, if y_1, y_2, \dots, y_m are the probabilities that r_1, r_2, \dots, r_m are the true accidental errors of x_1, x_2, \dots, x_m ,

$$\begin{aligned} y_2 &= \omega_2 e^{-\pi \frac{\omega_s^2}{k^2} w_2 r_2^2}, \\ &\dots \dots \dots \\ y_m &= \omega_m e^{-\pi \frac{\omega_s^2}{k^2} w_m r_m^2}. \end{aligned}$$

Hence, if P is the probability that all of the r 's are simultaneously equal to true accidental errors, we have

$$P = (\omega_1 \cdot \omega_2 \cdot \dots \cdot \omega_m) e^{-\pi \frac{\omega_s^2}{k^2} (w_1 r_1^2 + w_2 r_2^2 + \dots + w_m r_m^2)},$$

and the most probable value of X is that which renders P a maximum. Obviously, the maximum value of P occurs when

$(w_1r_1^2 + w_2r_2^2 + \dots + w_mr_m^2)$ is a minimum. Consequently the most probable value x_0 is given by the relation

$$\frac{\partial}{\partial x_0} (w_1r_1^2 + w_2r_2^2 + \dots + w_mr_m^2) = 0.$$

Substituting the values of the r 's and differentiating this becomes

$$w_1(x_1 - x_0) + w_2(x_2 - x_0) + \dots + w_m(x_m - x_0) = 0.$$

Hence,

$$x_0 = \frac{w_1x_1 + w_2x_2 + \dots + w_mx_m}{w_1 + w_2 + \dots + w_m},$$

as given above.

If we multiply or divide the numerator and denominator of equation (37) by any integral or fractional constant, the value of x_0 is unaltered. Hence, from (36), it is obvious that we are at liberty to choose any convenient value for E_s , whether or not it gives integral values to the w 's. Equations (36) also show that the weights of measurements are inversely proportional to the squares of their probable errors and consequently we may take

$$w_2 = w_1 \frac{E_1^2}{E_2^2}; \quad w_3 = w_1 \frac{E_1^2}{E_3^2}; \quad \dots \quad w_m = w_1 \frac{E_1^2}{E_m^2}. \quad (40)$$

Hence, if we choose, we can assign any arbitrary weight to one of the given measurements and compute the weights of the others by equation (40).

The foregoing methods for computing the weights w_1, w_2 , etc., are applicable only when the given measurements x_1, x_2 , etc., are entirely free from constant errors and mistakes. When this condition is not fulfilled the method breaks down because the errors of the x 's do not follow the law of accidental errors. In such cases it is sometimes possible to assign weights to the given measurements by combining the given probable errors with an estimate of the probable value of the constant errors, based on a thorough study of the methods by which the x 's were obtained. Such a procedure is always more or less arbitrary, and requires great care and experience, but when properly applied it leads to a closer approximation to the true numeric of the measured magnitude than would be obtained by taking the simple arithmetical mean of the x 's. Since it involves a knowledge of the laws of propagation of errors and of the methods for estimating the pre-

cision attained in removing constant errors and mistakes, it cannot be fully developed until we take up the study of the underlying principles.

46. Probable Error of the General Mean. — When the given x 's are free from constant errors and the E 's are known, the weights of the individual measurements are given by (36), and the weight w_0 of the general mean is given by (38). Consequently, if E_0 is the probable error of the general mean, we have by analogy with equations (36)

$$w_0 = \frac{E_s^2}{E_0^2} \quad \text{and} \quad E_0 = \frac{E_s}{\sqrt{w_0}}. \quad (41)$$

If we choose, E_0 may be expressed in terms of any one of the E 's in place of E_s . Thus, let E_n and w_n be the probable error and the weight of any one of the x 's, then by (36)

$$E_n = \frac{E_s}{\sqrt{w_n}},$$

and eliminating E_s between this equation and (41) we have

$$E_0 = E_n \sqrt{\frac{w_n}{w_0}}. \quad (42)$$

When the weights are assigned by the method outlined in the last paragraph of the preceding article, or when, for any reason, the w 's are given but not the E 's, (41) and (42) cannot be applied until E_s or E_n has been derived from the given x 's and w 's. If the number of given measurements is large, the value of E_s corresponding to the given weights can be computed with sufficient precision by the application of the law of errors as outlined below. If the number of given measurements is small, or if constant errors and mistakes have not been considered in assigning the weights, the following method gives only a rough approximation to the true value of E_s , and consequently of E_0 , since the conditions underlying the law of errors are not strictly fulfilled. It will be readily seen that while E_s may be arbitrarily assigned for the purpose of computing the weights, when the E 's are given, its value is fixed when the weights are given.

Let x_1, x_2, \dots, x_m represent the given measurements and w_1, w_2, \dots, w_m , the corresponding weights. Then, if ω_s repre-

sents the precision constant of a standard observation, and ω_1 that of an observation of weight w_1 , we have by (39)

$$w_1 = \frac{\omega_1^2}{\omega_s^2}; \quad \omega_1^2 = w_1 \omega_s^2.$$

Consequently, if y_Δ is the probability that the error of x_1 is equal to Δ ,

$$\begin{aligned} y_\Delta &= \omega_1 e^{-\pi \omega_1^2 \frac{\Delta^2}{k^2}} \\ &= \sqrt{w_1} \omega_s e^{-\pi \omega_s^2 \frac{w_1 \Delta^2}{k^2}}, \end{aligned}$$

and, by equation (11), article thirty-three, the probability that the error of x_1 lies between the limits Δ and $\Delta + d\Delta$ is

$$y_\Delta^{\Delta+d\Delta} = \frac{\omega_s}{k} e^{-\pi \omega_s^2 \frac{w_1 \Delta^2}{k^2}} \cdot \sqrt{w_1} d\Delta.$$

Now, $w_1 \Delta^2$ is the weighted square of the error Δ , and in the following pages the product $\sqrt{w} \Delta$ will be called a weighted error. Hence, if we put $\delta = \sqrt{w_1} \Delta$, and $d\delta = \sqrt{w_1} d\Delta$, we have for the probability that the weighted error of x_1 lies between the limits δ and $\delta + d\delta$

$$y_\delta^{\delta+d\delta} = \frac{\omega_s}{k} e^{-\pi \omega_s^2 \frac{\delta^2}{k^2}} d\delta.$$

Since the same result would have been obtained if we had started with any other one of the x 's and w 's, it is obvious that this equation expresses the probability that any one of the x 's, chosen at random, is affected by a weighted error lying between the limits δ and $\delta + d\delta$. But, if n_d is the number of x 's affected by weighted errors lying between these limits, and m is the total number of x 's, we have also

$$y_\delta^{\delta+d\delta} = \frac{n_d}{m},$$

or

$$n_d = m y_\delta^{\delta+d\delta}.$$

Hence, the sum of the squares of the weighted errors lying between δ and $\delta + d\delta$ is given by the relation

$$[\delta^2]_\delta^{\delta+d\delta} = n_d \delta^2 = m \delta^2 \frac{\omega_s}{k} e^{-\pi \omega_s^2 \frac{\delta^2}{k^2}} d\delta,$$

and, by the method adopted in articles thirty-six and thirty-seven, we have

$$\begin{aligned} \frac{[\delta^2]}{m} &= \frac{2 \omega_s}{k} \int_0^\infty \delta^2 e^{-\pi \omega_s^2 \frac{\delta^2}{k^2}} d\delta, \\ &= \frac{k^2}{2 \pi \omega_s^2}, \end{aligned}$$

where $[\delta^2]$ is supposed to include all possible weighted errors between the limits plus and minus infinity. Introducing the values of the δ 's in terms of the w 's and Δ 's this becomes

$$\frac{k^2}{2 \pi \omega_s^2} = \frac{w_1 \Delta_1^2 + w_2 \Delta_2^2 + \dots + w_m \Delta_m^2}{m} = \frac{[w \Delta^2]}{m},$$

which is an exact equation only when the number of measurements considered is practically infinite.

If M_s is the mean error of a standard observation, we have from equation (23)

$$M_s = \sqrt{\frac{k^2}{2 \pi \omega_s^2}} = \sqrt{\frac{[w \Delta^2]}{m}}.$$

Hence, from equation (26)

$$E_s = 0.6745 \sqrt{\frac{[w \Delta^2]}{m}}.$$

Now, we do not know the true value of the Δ 's and the number of given measurements is seldom sufficiently large to fulfill the conditions underlying this equation. But we can compute the general mean x_0 and the residuals

$$r_1 = x_1 - x_0; \quad r_2 = x_2 - x_0; \quad \dots \quad r_m = x_m - x_0,$$

and, by a method exactly analogous to that of article forty-one, it can be shown that the best approximation that we can make is given by the relation

$$\frac{[w \Delta^2]}{m} = \frac{[w r^2]}{m - 1}.$$

Hence, as a practicable formula for computing E_s , we have

$$E_s = 0.6745 \sqrt{\frac{[w r^2]}{m - 1}}, \quad (43)$$

and consequently E_0 is given by the relation

$$E_0 = 0.6745 \sqrt{\frac{[w r^2]}{w_0 (m - 1)}}, \quad (44)$$

in virtue of equation (41).

When the probable errors of the given measurements are known, and the weights are computed by equation (36), the value of E_s computed by equation (43) will agree with the value arbitrarily assigned, for the purpose of determining the w 's, provided the x 's are sufficiently numerous and free from constant errors and mistakes. The number of measurements considered is seldom sufficient to give exact agreement, but a large difference between the assigned and computed values of E_s is strong evidence that constant errors have not been removed with sufficient precision. On the other hand, satisfactory agreement may occur when all of the x 's are affected by the same constant error. Consequently such agreement is not a criterion for the absence of constant errors, but only for their equality in the different measurements.

47. Numerical Example. — As an illustration of the application of the foregoing principles, consider the micrometer measurements given under x in the following table. They represent the results of six series of measurements similar to that discussed in article forty-two, the last one being taken directly from that article. The probable errors, computed as in article forty-two, are given under E . They differ partly on account of differences in the number of observations in the several series, and partly from the fact that the individual observations were not of the same precision in all of the series. The squares of the probable errors multiplied by 10^4 are given under $E^2 \times 10^4$ to the nearest digit in the last place retained. It would be useless to carry them out further as the weights are to be computed to only two significant figures.

x	E	$E^2 \times 10^4$	w	$\sqrt{\frac{E_s^2}{w}}$
194.03	0.066	44	11	0.066
193.79	0.12	144	3	0.127
194.15	0.091	83	6	0.090
193.85	0.11	121	4	0.110
194.22	0.099	98	5	0.098
194.17	0.047	22	22	0.047

Taking E_s equal to 0.22 gives $E_s^2 \times 10^4$ equal to 484, and by applying equation (36), we obtain the weights given under w to the nearest integer. Inverting the process and computing the

E 's from the assigned w 's and E_s gives the numbers in the last column of the table. Since these numbers agree with the given E 's within less than two units in the second significant figure, we may assume that the approximation adopted in computing the w 's is justified. If the agreement was less exact and any of the differences exceeded two units in the second significant figure, it would be necessary to compute the w 's further, or, better, to adopt a different value for E_s , such that the agreement would be sufficient with integral values of the w 's.

For the purpose of computation, equation (37) may be written in the form

$$x_0 = C + \frac{w_1(x_1 - C) + w_2(x_2 - C) + \dots + w_m(x_m - C)}{w_1 + w_2 + \dots + w_m},$$

where C is any convenient number. In the present case 193 is chosen, and the products $w(x - 193)$ are given in the first column of the following table.

$w(x - 193)$	r	$r^2 \times 10^4$	$wr^2 \times 10^4$
11.33	-0.065	42	462
2.37	-0.305	930	2790
6.90	+0.055	30	180
3.40	-0.245	600	2400
6.10	+0.125	156	780
25.74	+0.075	56	1232
55.84			7844

Substitution in the above equation for the general mean gives

$$x_0 = 193 + \frac{55.84}{51} = 194.095,$$

and this is the most probable value that we can assign to the numeric of the measured magnitude on the basis of the given measurements.

By equation (38) the weight, w_0 , of the general mean is 51. Hence equation (41) gives

$$E_0 = \frac{0.22}{\sqrt{51}} = \pm 0.031$$

for the probable error of x_0 . Selecting the first measurement

since its weight corresponds exactly to its probable error, equation (42) gives

$$E_0 = 0.066 \sqrt{\frac{11}{51}} = \pm 0.031.$$

If the second, third, or fifth measurement had been chosen, the results derived by the two formulæ would not have been exactly alike; but the differences would amount to only a few units in the second significant figure, and consequently would be of no practical importance. However, it is better to proceed as above and select a measurement whose weight corresponds exactly with its probable error as shown by the fifth column of the first table above.

The residuals, computed by subtracting x_0 from each of the given measurements, are given under r in the second table; and their squares multiplied by 10^4 are given, to the nearest digit in the last place retained, under $r^2 \times 10^4$. The last column of the table gives the weighted squares of the residuals multiplied by 10^4 . The sum, $[wr^2]$, is equal to 0.784. Hence by equation (43)

$$E_s = 0.6745 \sqrt{\frac{0.784}{5}} = \pm 0.27,$$

and by equation (44)

$$E_0 = 0.6745 \sqrt{\frac{0.784}{51 \times 5}} = \pm 0.037.$$

These results agree with the assumed value of E_s and the previously computed value of E_0 as well as could be expected when so small a number of measurements are considered. Consequently we are justified in assuming that the given measurements are either free from constant errors or all affected by the same constant error.

In practice the second method of computing E_0 is seldom used when the probable errors of the given measurements are known, since its value as an indication of the absence of constant errors is not sufficient to warrant the labor involved. When the probable errors of the given measurements are not known it is the only available method for computing E_0 and it is carried out here for the sake of illustration.

CHAPTER VII.

THE METHOD OF LEAST SQUARES.

48. Fundamental Principles. — Let $X_1, X_2, \dots X_q$, and $Y_1, Y_2, \dots Y_n$ represent the true numerics of a number of quantities expressed in terms of a chosen system of units. Suppose that the quantities represented by the Y 's have been directly measured and that we wish to determine the remaining quantities indirectly with the aid of the given relations

$$\left. \begin{aligned} Y_1 &= F_1(X_1, X_2, \dots X_q), \\ Y_2 &= F_2(X_1, X_2, \dots X_q), \\ &\vdots \\ Y_n &= F_n(X_1, X_2, \dots X_q). \end{aligned} \right\} \quad (45)$$

The functions $F_1, F_2, \dots F_n$ may be alike or different in form and any one of them may or may not contain all of the X 's, but the exact form of each of them is supposed to be known.

If the Y 's were known and the number of equations were equal to the number of unknowns, the X 's could be derived at once by ordinary algebraic methods. The first condition is never fulfilled since direct measurements never give the true value of the numeric of the measured quantity. Let $s_1, s_2, \dots s_n$ represent the most probable values that can be assigned to the Y 's on the basis of the given measurements. If these values are substituted for the Y 's in (45), the equations will not be exactly fulfilled and consequently the true value of the X 's cannot be determined. The differences

$$\left. \begin{aligned} F_1(X_1, X_2, \dots X_q) - s_1 &= \Delta_1, \\ F_2(X_1, X_2, \dots X_q) - s_2 &= \Delta_2, \\ &\vdots \\ F_n(X_1, X_2, \dots X_q) - s_n &= \Delta_n \end{aligned} \right\} \quad (46)$$

represent the true accidental errors of the s 's.

Let $x_1, x_2, \dots x_q$ represent the most probable values that we can assign to the X 's on the basis of the given data. Then, since

the s 's bear a similar relation to the Y 's, equations (45) may be written in the form

$$\left. \begin{aligned} F_1(x_1, x_2, \dots, x_q) &= s_1, \\ F_2(x_1, x_2, \dots, x_q) &= s_2, \\ \cdot & \cdot \cdot \cdot \cdot \cdot \\ F_n(x_1, x_2, \dots, x_q) &= s_n, \end{aligned} \right\} \quad (47)$$

where the functions F_1, F_2 , etc., have exactly the same form as before. When the number of s 's is equal to the number of x 's, these equations give an immediate solution of our problem by ordinary algebraic methods; but in such cases we have no data for determining the precision with which the computed results represent the true numerics X_1, X_2 , etc.

Generally the number of s 's is far in excess of the number of unknowns and no system of values can be assigned to the x 's that will exactly satisfy all of the equations (47). If any assumed values of the x 's are substituted in (47), the differences

$$\left. \begin{aligned} F_1(x_1, x_2, \dots, x_q) - s_1 &= r_1, \\ F_2(x_1, x_2, \dots, x_q) - s_2 &= r_2, \\ \cdot & \cdot \cdot \cdot \cdot \cdot \\ F_n(x_1, x_2, \dots, x_q) - s_n &= r_n \end{aligned} \right\} \quad (48)$$

represent the residuals corresponding to the given s 's. "Obviously,"[?] the most probable values that we can assign to the x 's will be those that give a maximum probability that these residuals are equal to the true accidental errors Δ_1, Δ_2 , etc.

If the s 's are all of the same weight, the Δ 's all correspond to the same precision constant ω . Consequently, as in article thirty-five, the probability that the Δ 's are equal to the r 's is

$$\omega^n e^{-\pi \frac{\omega^2}{k^2} (r_1^2 + r_2^2 + \dots + r_n^2)}$$

and this is a maximum when

$$r_1^2 + r_2^2 + \dots + r_n^2 = [r^2] = \text{a minimum.} \quad (49)$$

Hence, as in direct measurements, the most probable values that we can assign to the desired numerics are those that render the sum of the squares of the residuals a minimum. For this reason the process of solution is called the method of least squares.

Since the r 's are functions of the q unknown quantities x_1, x_2 , etc., the conditions for a minimum in (49) are

$$\frac{\partial}{\partial x_1} [r^2] = 0; \quad \frac{\partial}{\partial x_2} [r^2] = 0; \quad \dots \quad \frac{\partial}{\partial x_q} [r^2] = 0, \quad (50)$$

provided the x 's are entirely independent in the mathematical sense, i.e., they are not required to fulfill any rigorous mathematical relation such as that which connects the three angles of a triangle. The equations (47) are not such conditions since the functions F_1, F_2 , etc., represent measured magnitudes and may take any value depending on the particular values of the x 's that obtain at the time of the measurements. When the r 's are replaced by the equivalent expressions in terms of the x 's and s 's as given in (48), the conditions (50) give q , and only q , equations from which the x 's may be uniquely determined.

If the weights of the s 's are different, the Δ 's correspond to different precision constants $\omega_1, \omega_2, \dots, \omega_n$ given by the relations

$$\omega_1 = \omega_s \sqrt{w_1}; \quad \omega_2 = \omega_s \sqrt{w_2}; \quad \dots \quad \omega_n = \omega_s \sqrt{w_n},$$

where ω_s is the precision constant corresponding to a standard measurement, i.e., a measurement of weight unity; and w_1, w_2, \dots, w_n are the weights of the s 's. Under these conditions, as in article forty-five, the most probable values of the x 's are those that render the sum of the weighted squares of the residuals a minimum. Thus, in the case of measurements of unequal weight, the condition (49) becomes

$$w_1 r_1^2 + w_2 r_2^2 + \dots + w_n r_n^2 = [wr^2] = \text{a minimum}, \quad (51)$$

and conditions (50) become

$$\frac{\partial}{\partial x_1} [wr^2] = 0; \quad \frac{\partial}{\partial x_2} [wr^2] = 0; \quad \dots \quad \frac{\partial}{\partial x_q} [wr^2] = 0. \quad (52)$$

49. Observation Equations. — The equations (50) or (52) can always be solved when all of the functions F_1, F_2, \dots, F_n are linear in form. Many problems arise in practice which do not satisfy this condition and frequently it is impossible or inconvenient to solve the equations in their original form. In such cases, approximate values are assigned to the unknown quantities and then the most probable corrections for the assumed values are computed by the method of least squares. Whatever the form

the normal equations become

$$\left. \begin{aligned} [waa] x_1 + [wab] x_2 + [wac] x_3 + \dots + [wap] x_q &= [was], \\ [wab] x_1 + [wbb] x_2 + [wbc] x_3 + \dots + [wbp] x_q &= [wbs], \\ [wac] x_1 + [wbc] x_2 + [wcc] x_3 + \dots + [wcp] x_q &= [wcs], \\ \vdots & \vdots \\ [wap] x_1 + [wbp] x_2 + [wcp] x_3 + \dots + [wpp] x_q &= [wps]. \end{aligned} \right\} (58)$$

These equations are identical in form with equations (56), and they may be solved under the same conditions and by the same methods as those equations. Consequently, in treating methods of solution, we shall consider the measurements to be of equal weight and utilize equations (56). All of these methods may be readily adapted to measurements of unequal weight by substituting the coefficients as given in (57) for those given in (55).

51. Solution with Two Independent Variables. — When only two independent quantities are to be determined the observation equations (53) become

$$\left. \begin{aligned} a_1 x_1 + b_1 x_2 &= s_1, \\ a_2 x_1 + b_2 x_2 &= s_2, \\ \vdots & \vdots \\ a_n x_1 + b_n x_2 &= s_n, \end{aligned} \right\} (53a)$$

and the normal equations (56) reduce to

$$\left. \begin{aligned} [aa] x_1 + [ab] x_2 &= [as], \\ [ab] x_1 + [bb] x_2 &= [bs]. \end{aligned} \right\} (56a)$$

Solving these equations we obtain

$$\left. \begin{aligned} x_1 &= \frac{[bb] [as] - [ab] [bs]}{[aa] [bb] - [ab]^2}, \\ x_2 &= \frac{[aa] [bs] - [ab] [as]}{[aa] [bb] - [ab]^2}. \end{aligned} \right\} (59)$$

As an illustration, consider the determination of the length L_0 at 0°C. , and the coefficient of linear expansion α of a metallic bar from the following measurements of its length L_t at temperature $t^\circ \text{C.}$

t	L_t
0°C.	mm.
20	1000.36
30	1000.53
40	1000.74
50	1000.91
60	1001.06

Within the temperature range considered, L_t and t are connected with L_0 and α by the relation

$$\begin{aligned} L_t &= L_0 (1 + \alpha t), \\ \text{or } L_t &= L_0 + L_0 \alpha t, \end{aligned} \tag{v}$$

and a set of observation equations might be written out at once by substituting the observed values of L_t and t in this equation. But the formation of the normal equations and the final solution is much simplified when the coefficients and absolute terms in the observation equations are small numbers of nearly the same order of magnitude. To accomplish this simplification, the above functional relation may be written in the equivalent form

$$\begin{aligned} \text{and if we put } L_t - 1000 &= L_0 - 1000 + 10 L_0 \alpha \frac{t}{10}, \\ L_t - 1000 &= s; \quad \frac{t}{10} = b, \\ L_0 - 1000 &= x_1; \quad 10 L_0 \alpha = x_2, \end{aligned} \tag{vi}$$

it becomes

$$x_1 + bx_2 = s.$$

Using this function, all of the a 's in equation (53a) become equal to unity and the b 's and s 's may be computed from the given observations by equations (vi). Hence, in the present case, the observation equations are

$$\begin{aligned} x_1 + 2x_2 &= .36, \\ x_1 + 3x_2 &= .53, \\ x_1 + 4x_2 &= .74, \\ x_1 + 5x_2 &= .91, \\ x_1 + 6x_2 &= 1.06. \end{aligned}$$

For the purpose of forming the normal equations, the squares and products of the coefficients and absolute terms are tabulated as follows:

Obs.	aa	ab	as	bb	bs
1	1	2	0.36	4	0.72
2	1	3	0.53	9	1.59
3	1	4	0.74	16	2.96
4	1	5	0.91	25	4.55
5	1	6	1.06	36	6.36
	5 [aa]	20 [ab]	3.60 [as]	90 [bb]	16.18 [bs]

Substituting these values of the coefficients in (56a) gives the normal equations

$$\begin{aligned}5x_1 + 20x_2 &= 3.60, \\20x_1 + 90x_2 &= 16.18,\end{aligned}$$

and by (59) we have

$$\begin{aligned}x_1 &= \frac{90 \times 3.60 - 20 \times 16.18}{5 \times 90 - 400} = 0.008, \\x_2 &= \frac{5 \times 16.18 - 20 \times 3.60}{5 \times 90 - 400} = 0.178.\end{aligned}$$

From these results, with the aid of relations (vi), we find

$$\begin{aligned}L_0 &= x_1 + 1000 = 1000.008, \\L_0\alpha &= \frac{x_2}{10} = 0.0178, \\ \alpha &= \frac{0.0178}{L_0} = 0.0000178,\end{aligned}$$

and finally

$$L_t = 1000.008 (1 + 0.0000178 t) \text{ millimeters.} \quad (\text{vii})$$

The differences between the values of L_t computed by equation (vii), and the observed values give the residuals. But they can be more simply determined by using the above values of x_1 and x_2 in the observation equations and taking the difference between the computed and observed values of s . Thus, if s' represents the computed value and r the corresponding residual

$$s' = 0.008 + 0.178 b,$$

and

$$r = s' - s.$$

With the values of s and b used in the observation equations we obtain the residuals as tabulated below:

s'	s	r	$r^2 \times 10^4$
0.364	0.36	+0.004	0.16
0.542	0.53	+0.012	1.44
0.720	0.74	-0.020	4.00
0.898	0.91	-0.012	1.44
1.076	1.06	+0.016	2.56
			$[r^2] = 9.60 \times 10^{-4}$

Since the above values of x_1 and x_2 were computed by the method of least squares, the resulting value of $[r^2]$, i.e., .000960, should be less than that obtainable with any other values of x_1 and x_2 . That this is actually the case may be verified by carrying out the computation with any other values of x_1 and x_2 .

52. **Adjustment of the Angles About a Point.** — As an illustration of the application of the method of least squares to the solution of a problem involving more than two unknown quantities, suppose that we wish to determine the most probable value of the angles A_1 , A_2 , and A_3 , Fig. 9, from a series of independent measurements of equal weight on the angles M_1 , M_2 , . . . M_6 . If the given measurements were all exact, the equations

$$A_1 = M_1; \quad A_2 = M_2; \quad A_3 = M_3;$$

$$A_1 + A_2 = M_4; \quad A_1 + A_2 + A_3 = M_5; \quad \text{and} \quad A_2 + A_3 = M_6,$$

would all be fulfilled identically. In practice this is never the case and it becomes necessary to adjust the values of the A 's so that the sum of the squares of the discrepancies will be a minimum. The adjustment may be effected by adopting the above equations as observation equations and proceeding at once to the solution for the A 's by the method of least squares. But the observed values of the M 's usually involve so many significant figures that the computation would be tedious. It is better to adopt approximate values for the A 's and then compute the necessary corrections by the method of least squares.

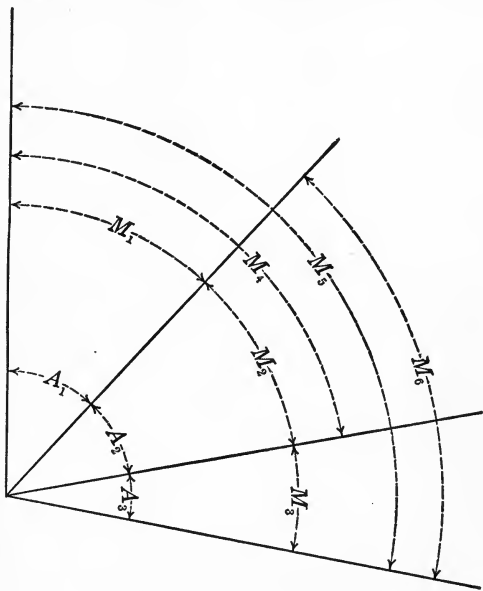

FIG. 9.

For this purpose, suppose we adopt M_1 , M_2 , and M_3 as approximate values of A_1 , A_2 , and A_3 respectively and let x_1 , x_2 , and x_3 represent the corrections that must be applied to the M 's in order to give the most probable values of the A 's. Then, putting

$$A_1 = M_1 + x_1, \quad A_2 = M_2 + x_2, \quad \text{and} \quad A_3 = M_3 + x_3, \quad (\text{viii})$$

the above equations become

$$\begin{aligned}
 x_1 &= 0, \\
 x_2 &= 0, \\
 x_3 &= 0, \\
 x_1 + x_2 &= M_4 - (M_1 + M_2), \\
 x_1 + x_2 + x_3 &= M_5 - (M_1 + M_2 + M_3), \\
 x_2 + x_3 &= M_6 - (M_2 + M_3).
 \end{aligned}$$

To render the problem definite, suppose that the following values of the M 's have been determined with an instrument reading to minutes of arc by verniers:

$$\begin{aligned}
 M_1 &= 10^\circ 49'.5, & M_4 &= 45^\circ 24'.0, \\
 M_2 &= 34^\circ 36'.0, & M_5 &= 60^\circ 53'.5, \\
 M_3 &= 15^\circ 25'.5, & M_6 &= 50^\circ 0'.0.
 \end{aligned}$$

Substituting these values in the above equations we obtain

$$\begin{aligned}
 x_1 &= 0, \\
 x_2 &= 0, \\
 x_3 &= 0, \\
 x_1 + x_2 &= -1'.5, \\
 x_1 + x_2 + x_3 &= 2'.5, \\
 x_2 + x_3 &= -1'.5.
 \end{aligned}$$

Adopting these as our observation equations and comparing with (53) we obtain the coefficients and absolute terms tabulated below:

Obs.	a	b	c	s
1	1	0	0	0
2	0	1	0	0
3	0	0	1	0
4	1	1	0	-1.5
5	1	1	1	2.5
6	0	1	1	-1.5

The squares and products of the coefficients and absolute terms may be tabulated, for the purpose of forming the normal equations, as follows:

aa	ab	ac	as	bb	bc	bs	cc	cs
1	0	0	0	0	0	0	0	0
0	0	0	0	1	0	0	0	0
0	0	0	0	0	0	0	1	0
1	1	0	-1.5	1	0	-1.5	0	0
1	1	1	2.5	1	1	2.5	1	2.5
0	0	0	0	1	1	-1.5	1	-1.5
3	2	1	1	4	2	-0.5	3	1
$[aa]$	$[ab]$	$[ac]$	$[as]$	$[bb]$	$[bc]$	$[bs]$	$[cc]$	$[cs]$

where the a 's, b 's, etc., are the coefficients in the given observation equations. Multiply the first of equations (60) by s_1 , the second by s_2 , etc., and add the products. The result is

$$[as] + [bs] + [cs] + \dots + [ps] = [ts]. \quad (61)$$

In the same way, multiplying by the a 's in order and adding, then by the b 's in order and adding, etc., we obtain the following relations

$$\left. \begin{aligned} [aa] + [ab] + [ac] + \dots + [ap] &= [at], \\ [ab] + [bb] + [bc] + \dots + [bp] &= [bt], \\ [ac] + [bc] + [cc] + \dots + [cp] &= [ct], \\ \cdot & \cdot \cdot \cdot \cdot \cdot \cdot \cdot \cdot \cdot \cdot \\ [ap] + [bp] + [cp] + \dots + [pp] &= [pt]. \end{aligned} \right\} \quad (62)$$

If the absolute terms in the normal equations have been accurately computed, equation (61) reduces to an identity. If the coefficients have been accurately computed equations (62) all become identities. Hence (61) is a check on the computation of the absolute terms and equations (62) bear the same relation to the coefficients. The extra labor involved in computing the quantities $[ts]$, $[at]$, . . . , $[pt]$ is more than repaid by the added confidence in the accuracy of the normal equations.

When all attainable significant figures are retained throughout the computations, the checks (61) and (62) should be identities. In practice the accuracy of the measurements is seldom sufficient to warrant so extensive a use of figures, and, consequently, the squares and products, aa , ab , . . . as , at , etc., are rounded to such an extent that the computed values of the x 's will come out with about the same number of significant figures as the given data. Judgment and experience are necessary in determining the number of significant figures that should be retained in any particular problem and it would be difficult to state a general rule that would not meet with many exceptions. When the computed coefficients and absolute terms are rounded, as above, the checks may not come out absolute identities, but they should not be accepted as satisfactory when the discrepancy is more than two units in the last place retained.

54. Gauss's Method of Solution. — When the normal equations (56) are entirely independent, they may be solved by any of the well-known methods for the solution of simultaneous linear equations and lead to unique values of the unknown quan-

tities x_1, x_2 , etc. Gauss's method of substitution is frequently adopted for this purpose since it permits the computation to be carried out in symmetrical form and provides numerous checks on the accuracy of the numerical work. The general principles of the method will be illustrated and explained by completely working out a case in which there are only three unknowns. Since the process of solution is entirely symmetrical, it can be easily extended for the determination of a larger number of unknowns, but too much space would be required to carry through the more general case here.

When only three unknowns are involved, the normal equations (56) and the check equations (60) and (61) may be completely written out in the following form, the computed quantities and equations being placed at the left, and the checks at the right.

$$\left. \begin{aligned} [aa]x_1 + [ab]x_2 + [ac]x_3 &= [as]. & [aa] + [ab] + [ac] &= [at]. \\ [ab]x_1 + [bb]x_2 + [bc]x_3 &= [bs]. & [ab] + [bb] + [bc] &= [bt]. \\ [ac]x_1 + [bc]x_2 + [cc]x_3 &= [cs]. & [ac] + [bc] + [cc] &= [ct]. \\ & & [as] + [bs] + [cs] &= [st]. \end{aligned} \right\} (63)$$

Solve the first equation on the left for x_1 , giving

$$x_1 = \frac{[as]}{[aa]} - \frac{[ab]}{[aa]}x_2 - \frac{[ac]}{[aa]}x_3. \quad (64)$$

Compute the following auxiliary quantities:

$$\begin{aligned} [bb] - \frac{[ab]}{[aa]}[ab] &= [bb \cdot 1], & [bt] - \frac{[ab]}{[aa]}[at] &= [bt \cdot 1], \\ [bc] - \frac{[ab]}{[aa]}[ac] &= [bc \cdot 1], & [ct] - \frac{[ac]}{[aa]}[at] &= [ct \cdot 1], \\ [bs] - \frac{[ab]}{[aa]}[as] &= [bs \cdot 1], & [st] - \frac{[as]}{[aa]}[at] &= [st \cdot 1]. \\ [cc] - \frac{[ac]}{[aa]}[ac] &= [cc \cdot 1], \\ [cs] - \frac{[ac]}{[aa]}[as] &= [cs \cdot 1], \end{aligned}$$

As a check on these computations we notice that

$$\begin{aligned} [bb \cdot 1] + [bc \cdot 1] &= [bb] + [bc] - \frac{[ab]}{[aa]}([ab] + [ac]), \\ &= [bt] - [ab] - \frac{[ab]}{[aa]}([at] - [aa]), \\ &= [bt] - \frac{[ab]}{[aa]}[at] = [bt \cdot 1]. \end{aligned}$$

In a similar way we may show that we should have

$$[bc \cdot 1] + [cc \cdot 1] = [ct \cdot 1] \quad \text{and} \quad [bs \cdot 1] + [cs \cdot 1] = [st \cdot 1].$$

Substituting (64) in the last two of (63) and placing the above checks to the right, we have the equations

$$\left. \begin{aligned} [bb \cdot 1] x_2 + [bc \cdot 1] x_3 &= [bs \cdot 1], & [bb \cdot 1] + [bc \cdot 1] &= [bt \cdot 1], \\ [bc \cdot 1] x_2 + [cc \cdot 1] x_3 &= [cs \cdot 1], & [bc \cdot 1] + [cc \cdot 1] &= [ct \cdot 1], \\ & & [bs \cdot 1] + [cs \cdot 1] &= [st \cdot 1], \end{aligned} \right\} \quad (65)$$

which show the same type of symmetry as (63), but contain only two unknown quantities. Solve the first of (65) for x_2 giving

$$x_2 = \frac{[bs \cdot 1]}{[bb \cdot 1]} - \frac{[bc \cdot 1]}{[bb \cdot 1]} x_3, \quad (66)$$

and compute the following auxiliaries:

$$\begin{aligned} [cc \cdot 1] - \frac{[bc \cdot 1]}{[bb \cdot 1]} [bc \cdot 1] &= [cc \cdot 2], & [ct \cdot 1] - \frac{[bc \cdot 1]}{[bb \cdot 1]} [bt \cdot 1] &= [ct \cdot 2], \\ [cs \cdot 1] - \frac{[bc \cdot 1]}{[bb \cdot 1]} [bs \cdot 1] &= [cs \cdot 2], & [st \cdot 1] - \frac{[bs \cdot 1]}{[bb \cdot 1]} [bt \cdot 1] &= [st \cdot 2]. \end{aligned}$$

By a method similar to that used above we can show that we should have

$$[cc \cdot 2] = [ct \cdot 2] \quad \text{and} \quad [cs \cdot 2] = [st \cdot 2].$$

Hence, substituting (66) in the last of (65), we have

$$\begin{aligned} [cc \cdot 2] x_3 &= [cs \cdot 2], & [cc \cdot 2] &= [ct \cdot 2], \\ & & [cs \cdot 2] &= [st \cdot 2], \end{aligned}$$

and consequently

$$x_3 = \frac{[cs \cdot 2]}{[cc \cdot 2]}. \quad (67)$$

Having determined the value of x_3 from (67), x_2 may be calculated from (66), and then x_1 from (64).

A very rigorous check on the entire computation is obtained as follows: using the computed values of x_1 , x_2 , and x_3 in equations (54), derive the residuals

$$\left. \begin{aligned} r_1 &= a_1 x_1 + b_1 x_2 + c_1 x_3 - s_1, \\ r_2 &= a_2 x_1 + b_2 x_2 + c_2 x_3 - s_2, \\ &\cdot \quad \cdot \quad \cdot \quad \cdot \quad \cdot \quad \cdot \\ r_n &= a_n x_1 + b_n x_2 + c_n x_3 - s_n, \end{aligned} \right\} \quad (68)$$

and then form the sums

$$\begin{aligned} [rr] &= r_1^2 + r_2^2 + r_3^2 + \dots + r_n^2, \\ [ss] &= s_1^2 + s_2^2 + s_3^2 + \dots + s_n^2. \end{aligned}$$

If the computations are all correct, the computed quantities will satisfy the relation

$$[rr] = [ss] - \frac{[as]}{[aa]}[as] - \frac{[bs \cdot 1]}{[bb \cdot 1]}[bs \cdot 1] - \frac{[cs \cdot 2]}{[cc \cdot 2]}[cs \cdot 2]. \quad (69)$$

To prove this, multiply the first of (68) by r_1 , the second by r_2 , etc., and add the products. The result is

$$[rr] = [ar]x_1 + [br]x_2 + [cr]x_3 - [sr].$$

But from equations (iii), article fifty,

$$[ar] = [br] = [cr] = 0,$$

consequently

$$[rr] = -[sr]. \quad (70)$$

Multiply each of equations (68) by its s ; add, taking account of (70), and we obtain

$$[rr] = [ss] - [as]x_1 - [bs]x_2 - [cs]x_3.$$

Eliminating x_1 , x_2 , and x_3 , in succession with the aid of (64), (66), and (67) we find

$$[rr] = [ss] - \frac{[as]}{[aa]}[as] - [bs \cdot 1]x_2 - [cs \cdot 1]x_3,$$

$$[rr] = [ss] - \frac{[as]}{[aa]}[as] - \frac{[bs \cdot 1]}{[bb \cdot 1]}[bs \cdot 1] - [cs \cdot 2]x_3,$$

and finally

$$[rr] = [ss] - \frac{[as]}{[aa]}[as] - \frac{[bs \cdot 1]}{[bb \cdot 1]}[bs \cdot 1] - \frac{[cs \cdot 2]}{[cc \cdot 2]}[cs \cdot 2],$$

which is identical with (69).

55. Numerical Illustration of Gauss's Method. — The foregoing methods are most frequently used for the adjustment of astronomical and geodetic observations, and their application to particular problems is fully discussed in practical treatises on such observations. The physical problems, to which they are applicable, usually involve the determination of an empirical relation between mutually varying quantities. Such problems will be discussed at some length in Chapter XIII, and the corresponding observation equations will be developed.

It would require too much space to carry out the complete discussion of such a problem, in this place, with all of the observations made in any actual investigation. But, for the purpose of illustration, the most probable values of x_1 , x_2 , and x_3 will be

derived, from the following typical observation equations, by Gauss's method of solution:

$$\begin{aligned}x_1 &= 0.24, \\x_1 + 2x_2 + 0.4x_3 &= -1.18, \\x_1 + 4x_2 + 1.6x_3 &= -1.53, \\x_1 + 6x_2 + 3.6x_3 &= -0.69, \\x_1 + 8x_2 + 6.4x_3 &= 1.20, \\x_1 + 10x_2 + 10.0x_3 &= 4.27.\end{aligned}$$

Since the coefficient of x_1 is unity in each of these equations, the products aa , ab , ac , as , and at are equal to a , b , c , s , and t , respectively. Consequently the first five columns of the following table show the coefficients, absolute terms, and check terms ($t = a + b + c$) of the observation equations as well as the squares and products indicated at the head of the columns. The sums $[aa]$, $[ab]$, etc., are given at the foot of the columns and the checks, by equations (61) and (62), are given below the tables. In the present case, the coefficients are expressed by so few significant figures that it is not necessary to round the computed products and consequently the checks come out identities.

aa	ab	ac	as	at	bb	bc
1	0	0.0	0.24	1.0	0	0.0
1	2	0.4	-1.18	3.4	4	0.8
1	4	1.6	-1.53	6.6	16	6.4
1	6	3.6	-0.69	10.6	36	21.6
1	8	6.4	1.20	15.4	64	51.2
1	10	10.0	4.27	21.0	100	100.0
6	30	22.0	2.31	58.0	220	180.0
$[aa]$	$[ab]$	$[ac]$	$[as]$	$[at]$	$[bb]$	$[bc]$
Check: $[aa] + [ab] + [ac] = 58.0$.						

bs	cc	cs	bt	ct	st
0.00	0.00	0.00	0.0	0.00	0.24
-2.36	0.16	-0.472	6.8	1.36	-4.012
-6.12	2.56	-2.448	26.4	10.56	-10.098
-4.14	12.96	-2.484	63.6	38.16	-7.314
9.60	40.96	7.680	123.2	98.56	18.480
42.70	100.00	42.700	210.0	210.00	89.670
39.68	156.64	44.976	430.0	358.64	86.966
$[bs]$	$[cc]$	$[cs]$	$[bt]$	$[ct]$	$[st]$
Checks: $[ab] + [bb] + [bc] = 430.0$					
$[ac] + [bc] + [cc] = 358.64$					
$[as] + [bs] + [cs] = 86.966$					

The normal equations and their checks might now be written out in the form of equations (63), but, since the coefficients and other data necessary for their solution are all tabulated above, it is scarcely worth while to repeat the same data in the form of equations. The computation of the auxiliaries $[bb \cdot 1]$, $[bc \cdot 1]$, etc., and the final solution for x_1 , x_2 , and x_3 by logarithms is best carried out in tabular form as illustrated on pages 90 and 91. The meaning of the various quantities appearing in these tables, and the methods by which they are computed, will be readily understood by comparing the numerical process with the literal equations of the preceding article. When the letter n appears after a logarithm it indicates that the corresponding number is to be taken negative in all computations.

The computation of the residuals by equations (68) and the final check by (69) is carried out in the following table, where $s_{\text{calc.}}$ is written for the value of the expression $ax_1 + bx_2 + cx_3$, when the computed values of x_1 , x_2 , and x_3 are used and $s_{\text{obs.}}$ is the corresponding value of s in the observation equations. Thus

$$r_1 = a_1x_1 + b_1x_2 + c_1x_3 - s_1 = s_{1 \text{ calc.}} - s_{1 \text{ obs.}}$$

$s_{\text{calc.}}$	$s_{\text{obs.}}$	r	$r^2 \times 10^6$	ss
0.245	0.24	+0.005	25	0.0576
-1.195	-1.18	-0.015	225	1.3924
-1.512	-1.53	+0.018	324	2.3409
-0.709	-0.69	-0.019	361	0.4761
1.215	1.20	+0.015	225	1.4400
4.264	4.27	-0.006	36	18.2329
			.001196 [rr]	23.9399 [ss]
$\frac{[as]}{[aa]}[as]$	$\frac{[bs \cdot 1]}{[bb \cdot 1]}[bs \cdot 1]$	$\frac{[cs \cdot 2]}{[cc \cdot 2]}[cs \cdot 2]$		
0.8893	+ 11.3042	+ 11.7452	=	23.9387
	Final check by (69):	[rr]	=	0.0012

Since the checks are all satisfactory, we are justified in assuming that the computations are correct. Hence the most probable values of the unknowns, derivable from the given observation equations, are

$$x_1 = 0.245; \quad x_2 = -1.0003; \quad x_3 = 1.4022,$$

$[aa] = 6$ $\log [aa] = 0.77815$	$[ab] = 30$ $\log [ab] = 1.47712$ $\log \frac{[ab]}{[aa]} = 0.69897$	$[ac] = 22.0$ $\log [ac] = 1.34242$ $\log \frac{[ac]}{[aa]} = 0.56427$	$[as] = 2.31$ $\log [as] = 0.36361$ $\log \frac{[as]}{[aa]} = 1.58546$	$[at] = 58.0$ $\log [at] = 1.76343$	Checks
	$[bb] = 220$ $\log \frac{[ab]}{[aa]} [ab] = 2.17609$ anti-log = 150 $[bb \cdot 1] = 70$	$[bc] = 180.0$ $\log \frac{[ab]}{[aa]} [ac] = 2.04139$ anti-log = 110.0 $[bc \cdot 1] = 70.0$	$[bs] = 39.68$ $\log \frac{[ab]}{[aa]} [as] = 1.06258$ anti-log = 11.55 $[bs \cdot 1] = 28.13$	$[bt] = 430.0$ $\log \frac{[ab]}{[aa]} [at] = 2.46240$ anti-log = 290.0 $[bt \cdot 1] = 140.0$	$[bb \cdot 1] + [bc \cdot 1]$ 140.0
		$[cc] = 156.64$ $\log \frac{[ac]}{[aa]} [ac] = 1.90669$ anti-log = 80.6667 $[cc \cdot 1] = 75.9733$	$[cs] = 44.976$ $\log \frac{[ac]}{[aa]} [as] = .92788$ anti-log = 8.470 $[cs \cdot 1] = 36.506$	$[ct] = 358.64$ $\log \frac{[ac]}{[aa]} [at] = 2.32770$ anti-log = 212.6667 $[ct \cdot 1] = 145.9733$	$[bc \cdot 1] + [cc \cdot 1]$ 145.9733
				$[st] = 86.966$ $\log \frac{[as]}{[aa]} [at] = 1.34889$ anti-log = 22.330 $[st \cdot 1] = 64.636$	$[bs \cdot 1] + [cs \cdot 1]$ 64.636

$[bb \cdot 1] = 70$ $\log [bb \cdot 1] = 1.84510$	$[bc \cdot 1] = 70.0$ $\log [bc \cdot 1] = 1.84510$ $\log \frac{[bc \cdot 1]}{[bb \cdot 1]} = 0.00000$	$[bs \cdot 1] = 28.13$ $\log [bs \cdot 1] = 1.44917$ $\log \frac{[bs \cdot 1]}{[bb \cdot 1]} = 1.60407$	$[bt \cdot 1] = 140$ $\log [bt \cdot 1] = 2.14613$	Checks
$[cc \cdot 1] = 75.9733$ $\log \frac{[bc \cdot 1]}{[bb \cdot 1]} [bc \cdot 1] = 1.84510$ $\text{anti-log} = 70.00$ $[cc \cdot 2] = 5.9733$	$[cs \cdot 1] = 36.506$ $\log \frac{[bc \cdot 1]}{[bb \cdot 1]} [bs \cdot 1] = 1.44917$ $\text{anti-log} = 28.13$ $[cs \cdot 2] = 8.376$	$[ct \cdot 1] = 145.9733$ $\log \frac{[bc \cdot 1]}{[bb \cdot 1]} [bt \cdot 1] = 2.14613$ $\text{anti-log} = 140$ $[ct \cdot 2] = 5.9733$	$[cc \cdot 2]$ 5.9733	
$\log [cc \cdot 2] = 0.77622$	$\log [cs \cdot 2] = 0.92304$ $\log x_3 = 0.14682$ $x_3 = 1.4022$	$[st \cdot 1] = 64.636$ $\log \frac{[bs \cdot 1]}{[bb \cdot 1]} [bt \cdot 1] = 1.75020$ $\text{anti-log} = 56.26$ $[st \cdot 2] = 8.376$	$[cs \cdot 2]$ 8.376	
$\frac{[as]}{[aa]} = 0.385$ $\log \frac{[ab]}{[aa]} x_2 = 0.69910$ $\text{anti-log} = -5.0015$ $\log \frac{[ac]}{[aa]} x_3 = 0.71109$ $\text{anti-log} = 5.1415$ $x_1 = 0.245$ $\log x_1 = 1.38917$	$\frac{[bs \cdot 1]}{[bb \cdot 1]} = 0.4019$ $\log \frac{[bc \cdot 1]}{[bb \cdot 1]} x_3 = 0.14682$ $\text{anti-log} = 1.4022$ $x_2 = -1.0003$ $\log x_2 = 0.00013$	$[bs \cdot 1]$ $[bb \cdot 1]$ $[bc \cdot 1]$ $[bb \cdot 1]$ $x_3 = 0.14682$ $\text{anti-log} = 1.4022$ $x_2 = -1.0003$ $\log x_2 = 0.00013$	$[cs \cdot 2]$ 8.376	

and the corresponding empirical relation becomes

$$s = 0.245 a - 1.0003 b + 1.4022 c.$$

A small number of observation equations with simple coefficients have been chosen, in the above illustration, partly to save space and partly in order that the computations may be more readily followed. In practice it would seldom be worth while to apply the method of least squares to so small a number of observations or to adopt Gauss's method of solution with logarithms when the normal equations are so simple. When the number of observations is large and the coefficients involve more than three or four significant figures, the method given above will be found very convenient on account of the numerous checks and the symmetry of the computations. In order to furnish a model for more complicated problems, the process has been carried out completely even in the parts where the results might have been foreseen without the use of logarithms.

56. Conditioned Quantities. — When the unknown quantities, x_1, x_2 , etc., are not independent in the mathematical sense, the foregoing method breaks down since the equations (50) no longer express the condition for a minimum of $[rr]$. In such cases the number of unknowns may be reduced by eliminating as many of them as there are rigorous mathematical relations to be fulfilled. The remaining unknowns are independent and may be determined as above. The eliminated quantities are then determined with the aid of the given mathematical conditions.

For the purpose of illustration, consider the case of a single rigorous relation between the unknowns, and let the corresponding mathematical condition be represented by the equation

$$\theta(x_1, x_2, \dots, x_q) = 0. \quad (71)$$

As in the case of unconditioned quantities, the observation equations (53) are

$$\left. \begin{aligned} a_1x_1 + b_1x_2 + c_1x_3 + \dots + p_1x_q &= s_1, \\ a_2x_1 + b_2x_2 + c_2x_3 + \dots + p_2x_q &= s_2, \\ \cdot & \cdot \cdot \cdot \cdot \cdot \cdot \cdot \cdot \cdot \cdot \\ a_nx_1 + b_nx_2 + c_nx_3 + \dots + p_nx_q &= s_n. \end{aligned} \right\} \quad (53)$$

The solution of (71) for x_1 , in terms of x_2, x_3, \dots, x_q , may be written in the form

$$x_1 = f(x_2, x_3, \dots, x_q). \quad (72)$$

Introducing this value of x_1 , equations (53) become

$$a_1 f(x_2, x_3, \dots, x_q) + b_1 x_2 + c_1 x_3 + \dots + p_1 x_q = s_1,$$

$$a_2 f(x_2, x_3, \dots, x_q) + b_2 x_2 + c_2 x_3 + \dots + p_2 x_q = s_2,$$

$$\dots$$

$$a_n f(x_2, x_3, \dots, x_q) + b_n x_2 + c_n x_3 + \dots + p_n x_q = s_n.$$

Since the form of θ is known, that of f is also known. Hence, by collecting the terms in x_2, x_3 , etc., and reducing to linear form, if necessary, we have

$$b_1' x_2 + c_1' x_3 + \dots + p_1' x_q = s_1',$$

$$b_2' x_2 + c_2' x_3 + \dots + p_2' x_q = s_2',$$

$$\dots$$

$$b_n' x_2 + c_n' x_3 + \dots + p_n' x_q = s_n'.$$

The x 's in these equations are independent, and, consequently, they may be determined by the methods of the preceding articles. Using the values thus obtained in (71) or (72) gives the remaining unknown x_1 . The x 's, thus determined, obviously satisfy the mathematical condition (71) exactly, and give the least magnitude to the quantity $[rr]$ that is consistent with that condition. They are, consequently, the most probable values that can be assigned on the basis of the given data.

As a very simple example, consider the adjustment of the angles of a plane triangle. Suppose that the observed values of the angles are

$$s_1 = 60^\circ 1'; \quad s_2 = 59^\circ 58'; \quad s_3 = 59^\circ 59'.$$

The adjusted values must satisfy the condition

$$x_1 + x_2 + x_3 = 180^\circ,$$

or

$$x_1 = 180^\circ - x_2 - x_3.$$

Eliminating x_1 from the observation equations,

$$x_1 = s_1; \quad x_2 = s_2; \quad \text{and} \quad x_3 = s_3;$$

and substituting numerical values we have

$$x_2 + x_3 = 119^\circ 59',$$

$$x_2 = 59^\circ 58',$$

$$x_3 = 59^\circ 59'.$$

The corresponding normal equations are

$$2x_2 + x_3 = 179^\circ 57',$$

$$x_2 + 2x_3 = 179^\circ 58',$$

from which we find

$$x_2 = 59^\circ 58'.7 \text{ and } x_3 = 59^\circ 59'.7.$$

Then, from the equation of condition,

$$x_1 = 60^\circ 1'.6.$$

When there are two relations between the unknowns, expressed by the equations

$$\theta_1(x_1, x_2, \dots, x_q) = 0,$$

$$\theta_2(x_1, x_2, \dots, x_q) = 0,$$

they may be solved simultaneously for x_1 and x_2 , in terms of the other x 's, in the form

$$x_1 = f_1(x_3, x_4, \dots, x_q),$$

$$x_2 = f_2(x_3, x_4, \dots, x_q).$$

Using these in the observation equations (53) we obtain a new set of equations, independent of x_1 and x_2 , that may be solved as above. It will be readily seen that this process can be extended to include any number of equations of condition.

When the number of conditions is greater than two, the computation by the above method becomes too complicated for practical application and special methods have been devised for dealing with such cases. The development of these methods is beyond the scope of the present work, but they may be found in treatises on geodesy and practical astronomy in connection with the problems to which they apply.

CHAPTER VIII.

PROPAGATION OF ERRORS.

57. Derived Quantities. — In one class of indirect measurements, the desired numeric X is obtained by computation from the numerics X_1, X_2 , etc., of a number of directly measured magnitudes, with the aid of the known functional relation

$$X = F(X_1, X_2, \dots, X_q).$$

We have seen that the most probable value that we can assign to the numeric of a directly measured quantity is either the arithmetical mean of a series of observations of equal weight or the general mean of a number of measurements of different weight. Consequently, if x_1, x_2, \dots, x_q represent the proper means of the observations on X_1, X_2, \dots, X_q the most probable value x that we can assign to X is given by the relation

$$x = F(x_1, x_2, \dots, x_q)$$

where F has the same form as in the preceding equation.

Obviously, the characteristic errors of x cannot be easily determined by a direct application of the methods discussed in Chapters V and VI, as this would require a separate computation of x from each of the individual observations on which x_1, x_2 , etc., depend. Furthermore, it frequently happens that we do not know the original observations and are thus obliged to base our computations on the given mean values, x_1, x_2 , etc., together with their characteristic errors.

Hence it becomes desirable to develop a process for computing the characteristic errors of x from the corresponding errors of x_1, x_2 , etc. For this purpose we will first discuss several simple forms of the function F and from the results thus obtained we will derive a general process applicable to any form of function.

58. Errors of the Function $X_1 \pm X_2 \pm X_3 \pm \dots \pm X_q$.

Suppose that the given function is in the form

$$X = X_1 + X_2, \text{ or } X = X_1 - X_2.$$

These two cases can be treated together by writing the function in the form

$$X = X_1 \pm X_2,$$

Since Δa and Δb are true accidental errors, they are distributed in conformity with the three axioms stated in article twenty-four. Consequently equal positive and negative values of Δa and Δb are equally probable and the term $[\Delta a \Delta b]$ would vanish if an infinite number of observations were considered. In any case it is negligible in comparison with the other terms in the above equation. Hence, on dividing through by n , we have

$$\frac{[(\Delta A)^2]}{n} = \frac{[(\Delta a)^2]}{n} + \frac{[(\Delta b)^2]}{n},$$

and by equation (20), article thirty-seven, this becomes

$$M_A^2 = M_a^2 + M_b^2, \quad (73)$$

where M_A is the mean error of a single A , M_a that of a single a , and M_b that of a single b . Since x , x_1 , and x_2 are the arithmetical means of the A 's, a 's, and b 's, respectively, their respective mean errors, M , M_1 , and M_2 , are given by the relations

$$M^2 = \frac{M_A^2}{n}, \quad M_1^2 = \frac{M_a^2}{n}, \quad \text{and} \quad M_2 = \frac{M_b^2}{n}$$

in virtue of equations (29), article forty. Consequently, by (73)

$$M^2 = M_1^2 + M_2^2,$$

or

$$M = \sqrt{M_1^2 + M_2^2}. \quad (74)$$

Since the mean and probable errors, corresponding to the same series of observations, are connected by the constant relation (26), article thirty-nine, we have also

$$E = \sqrt{E_1^2 + E_2^2}, \quad (75)$$

where E , E_1 , and E_2 are the probable errors of x , x_1 , and x_2 , respectively.

It should be noticed that the ambiguous sign does not appear in the expressions for the characteristic errors. The square of the error of the computed quantity is equal to the sum of the squares of the corresponding errors of the directly measured quantities; whether the sign in the functional relation is positive or negative. Thus the error of the sum of two quantities is equal to the corresponding error of the difference of the same two quantities.

Now suppose that the given functional relation is in the form

$$X = X_1 \pm X_2 \pm X_3.$$

The most probable value of X is given by the relation

$$x = x_1 \pm x_2 \pm x_3,$$

where the notation has the same meaning as in the preceding case. Represent $x_1 \pm x_2$ by x_p , then

$$x = x_p \pm x_3,$$

and, by an obvious extension of the notation used above, we have

$$\begin{aligned} M_p^2 &= M_1^2 + M_2^2, \\ M^2 &= M_p^2 + M_3^2 \\ &= M_1^2 + M_2^2 + M_3^2. \end{aligned}$$

Passing to the more general relation

$$X = X_1 \pm X_2 \pm X_3 \pm \dots \pm X_q,$$

we have $x = x_1 \pm x_2 \pm x_3 \pm \dots \pm x_q$,

and, by repeated application of the above process,

$$\left. \begin{aligned} M^2 &= M_1^2 + M_2^2 + M_3^2 + \dots + M_q^2, \\ E^2 &= E_1^2 + E_2^2 + E_3^2 + \dots + E_q^2. \end{aligned} \right\} \quad (76)$$

Thus the square of the error of the algebraic sum of a series of terms is equal to the sum of the squares of the corresponding errors of the separate terms whatever the signs of the given terms may be.

59. Errors of the Function $\alpha_1 X_1 \pm \alpha_2 X_2 \pm \alpha_3 X_3 \pm \dots \pm \alpha_q X_q$.

Let the given functional relation be in the form

$$X = \alpha_1 X_1,$$

where α_1 is any positive or negative, integral or fractional, constant. The most probable value that we can assign to X on the basis of n equally good independent measurements of X is

$$x = \alpha_1 x_1,$$

where x_1 is the arithmetical mean of the n direct observations $a_1, a_2, a_3, \dots, a_n$.

The n independent values of X obtainable from the given observations are

$$A_1 = \alpha_1 a_1, \quad A_2 = \alpha_1 a_2, \quad \dots, \quad A_n = \alpha_1 a_n.$$

The accidental errors of the a 's and A 's are

$$\Delta a_1 = a_1 - X_1, \quad \Delta a_2 = a_2 - X_1, \quad \dots, \quad \Delta a_n = a_n - X_1,$$

and

$$\Delta A_1 = A_1 - X, \quad \Delta A_2 = A_2 - X, \quad \dots, \quad \Delta A_n = A_n - X.$$

Combining these equations we find

$$\begin{aligned}\Delta A_1 &= \alpha_1 a_1 - \alpha_1 X_1 \\ &= \alpha_1 \Delta a_1,\end{aligned}$$

and similar expressions for the other ΔA 's. Consequently

$$(\Delta A_1)^2 = \alpha_1^2 (\Delta a_1)^2,$$

and $[(\Delta A)^2] = \alpha_1^2 [(\Delta a)^2]$.

If M and M_1 are the mean errors of x and x_1 , respectively,

$$M^2 = \frac{[(\Delta A)^2]}{n^2}, \quad \text{and} \quad M_1^2 = \frac{[(\Delta a)^2]}{n^2}.$$

Hence $M^2 = \alpha_1^2 M_1^2$, (77)

and, since the probable error bears a constant relation to the mean error,

$$E^2 = \alpha_1^2 E_1^2. \quad (78)$$

When the given functional relation is in the more general form

$$X = \alpha_1 X_1 \pm \alpha_2 X_2 \pm \alpha_3 X_3 \pm \dots \pm \alpha_q X_q,$$

we have

$$x = \alpha_1 x_1 \pm \alpha_2 x_2 \pm \alpha_3 x_3 \pm \dots \pm \alpha_q x_q,$$

where the x 's are the most probable values that can be assigned to the X 's on the basis of the given measurements. Applying (77) and (78) to each term of this equation separately and then applying (76) we have

$$\left. \begin{aligned}M^2 &= \alpha_1^2 M_1^2 + \alpha_2^2 M_2^2 + \alpha_3^2 M_3^2 + \dots + \alpha_q^2 M_q^2, \\ E^2 &= \alpha_1^2 E_1^2 + \alpha_2^2 E_2^2 + \alpha_3^2 E_3^2 + \dots + \alpha_q^2 E_q^2,\end{aligned} \right\} \quad (79)$$

where the M 's and E 's represent respectively the mean and probable errors of the x 's with corresponding subscripts.

60. Errors of the Function $F(X_1, X_2, \dots, X_q)$.

We are now in a position to consider the general functional relation

$$X = F(X_1, X_2, \dots, X_q),$$

where F represents any function of the independently measured quantities X_1, X_2 , etc. Introducing the most probable values of the observed numerics, the most probable value of the computed numeric is given by the relation

$$x = F(x_1, x_2, \dots, x_q). \quad (80)$$

This expression may be written in the form

$$x = F\{l_1 + \delta_1, (l_2 + \delta_2, \dots, (l_q + \delta_q)\}, \quad (i)$$

where the l 's represent arbitrary constants and the δ 's are small corrections given by relations in the form

$$\delta_1 = x_1 - l_1.$$

Obviously, the errors of the δ 's are equal to the errors of the corresponding x 's. For, if M_1 , M_δ , and M_l are the errors of x_1 , δ_1 , and l_1 , respectively, we have by equation (74)

$$M_\delta^2 = M_1^2 + M_l^2.$$

But M_l is equal to zero, because l is an arbitrary quantity and any value assigned to it may be considered exact. Consequently

$$M_\delta^2 = M_1^2. \tag{ii}$$

Since the l 's are arbitrary, they may be so chosen that the squares and higher powers of the δ 's will be negligible in comparison with the δ 's themselves. Hence, if the x 's are independent, (i) may be expanded by Taylor's Theorem in the form

$$x = F(l_1, l_2, \dots, l_q) + \frac{\partial F}{\partial x_1} \delta_1 + \frac{\partial F}{\partial x_2} \delta_2 + \dots + \frac{\partial F}{\partial x_q} \delta_q,$$

where
$$\frac{\partial F}{\partial x_1} = \frac{\partial}{\partial x_1} F(x, x, \dots, x) = \frac{\partial x}{\partial x_1},$$

and the other differential coefficients have a similar significance. When the observed values of the x 's are substituted in these coefficients, they become known numerical constants.

The mean error of $F(l_1, l_2, \dots, l_q)$ is equal to zero, since it is a function of arbitrary constants; and the mean errors of the δ 's are equal to the mean errors of the corresponding x 's by (ii). Consequently, if M, M_1, M_2, \dots, M_q represent the mean errors of x, x_1, x_2, \dots, x_q , respectively, we have by equation (79)

$$\left. \begin{aligned} M^2 &= \left(\frac{\partial F}{\partial x_1} M_1\right)^2 + \left(\frac{\partial F}{\partial x_2} M_2\right)^2 + \dots + \left(\frac{\partial F}{\partial x_q} M_q\right)^2, \\ E^2 &= \left(\frac{\partial F}{\partial x_1} E_1\right)^2 + \left(\frac{\partial F}{\partial x_2} E_2\right)^2 + \dots + \left(\frac{\partial F}{\partial x_q} E_q\right)^2, \end{aligned} \right\} \tag{81}$$

where the E 's represent the probable errors of the x 's with corresponding subscripts.

Equations (81) are general expressions for the mean and probable errors of derived quantities in terms of the corresponding errors of the independent components. Generally x_1, x_2 , etc.,

represent either the arithmetical or the general means of series of direct observations on the corresponding components, and E_1, E_2 , etc., can be computed by equations (32) or (41). In some cases, the original observations are not available but the mean values together with their probable errors are given.

For the purpose of computing the numerical value of the differential coefficients $\frac{\partial F}{\partial x_1}, \frac{\partial F}{\partial x_2}$, etc., the given or observed values of the components x_1, x_2 , etc., may generally be rounded to three significant figures. This greatly reduces the labor of computation and does not reduce the precision of the result, since the E 's and M 's are seldom given or desired to more than two significant figures.

61. Example Introducing the Fractional Error. — The practical application of the foregoing process is illustrated in the following simple example: the volume V of a right circular cylinder is computed from measurements of the diameter D and the length L , and we wish to determine the probable error of the result. In this case, V corresponds to x , D to x_1 , L to x_2 , and the functional relation (80) becomes

$$V = \frac{1}{4} \pi D^2 L.$$

Also, if E_V, E_D , and E_L are the probable errors of V, D , and L , respectively, the second of equations (81) becomes

$$E_V^2 = \left(\frac{\partial V}{\partial D} E_D \right)^2 + \left(\frac{\partial V}{\partial L} E_L \right)^2,$$

where

$$\frac{\partial V}{\partial D} = \frac{\partial}{\partial D} \left(\frac{1}{4} \pi D^2 L \right) = \frac{1}{2} \pi D L,$$

and

$$\frac{\partial V}{\partial L} = \frac{\partial}{\partial L} \left(\frac{1}{4} \pi D^2 L \right) = \frac{1}{4} \pi D^2.$$

Hence

$$E_V^2 = \frac{1}{4} \pi^2 D^2 L^2 E_D^2 + \frac{1}{16} \pi^2 D^4 E_L^2.$$

The computation can be simplified by introducing the fractional error $\frac{E_V}{V}$. Thus, dividing the above equation by

$$V^2 = \frac{1}{16} \pi^2 D^4 L^2,$$

we have

$$\frac{E_V^2}{V^2} = 4 \frac{E_D^2}{D^2} + \frac{E_L^2}{L^2},$$

or, writing P_V , P_D , and P_L for the fractional errors,

$$P_V^2 = 4P_D^2 + P_L^2,$$

$$P_V = \sqrt{4P_D^2 + P_L^2};$$

and finally

$$E_V = VP_V = V \sqrt{4P_D^2 + P_L^2}.$$

A similar simplification can be effected, in dealing with many other practical problems, by the introduction of the fractional errors. Consequently it is generally worth while to try this expedient before attempting the direct reduction of the general equation (81).

In order to render the problem specific, suppose that

$$D = 15.67 \pm 0.13 \text{ mm.},$$

$$L = 56.25 \pm 0.65 \text{ mm.},$$

then

$$V = 10848 \overline{\text{mm.}}^3$$

and

$$P_D = \frac{E_D}{D} = \frac{0.13}{15.7} = .0083; \quad P_D^2 = 69 \times 10^{-6},$$

$$P_L = \frac{E_L}{L} = \frac{0.65}{56.2} = .0116; \quad P_L^2 = 135 \times 10^{-6},$$

$$P_V = \sqrt{(4 \times 69 + 135) \times 10^{-6}} = 0.020,$$

$$E_V = VP_V = 220 \overline{\text{mm.}}^3$$

Hence

$$V = 10.85 \pm 0.22 \overline{\text{cm.}}^3$$

62. Fractional Error of the Function $\alpha X_1^{\pm n_1} \times X_2^{\pm n_2} \times \dots \times X_q^{\pm n_q}$.—

Suppose the given relation is in the form

$$X = F(X_1) = \alpha X_1^{\pm n},$$

where α and n are constants and the \pm sign of the exponent n is used for the purpose of including the two functions αX_1^{+n} and αX_1^{-n} in the same discussion. In this case equation (80) becomes

$$x = \alpha x_1^{\pm n},$$

and the second of (81) reduces to

$$E^2 = \left(\frac{\partial F}{\partial x_1} E_1 \right)^2.$$

But

$$\frac{\partial F}{\partial x_1} = \frac{\partial}{\partial x_1} (\alpha x_1^{\pm n}) = \pm n \alpha x_1^{\pm n-1}.$$

Consequently

$$E^2 = n^2 \alpha^2 x_1^{\pm 2n-2} E_1^2.$$

If P and P_1 are the fractional errors of x and x_1 , respectively, we have

$$\begin{aligned} P^2 &= \frac{E^2}{x^2} = \frac{n^2 \alpha^2 x_1^{\pm 2n-2}}{\alpha^2 x_1^{\pm 2n}} E_1^2 \\ &= n^2 \frac{E_1^2}{x_1^2} = n^2 P_1^2. \end{aligned}$$

Hence

$$P = nP_1. \quad (82)$$

If we replace n by $\frac{1}{m}$ in the above argument, (80) becomes

$$x = \alpha x_1^{\pm \frac{1}{m}},$$

and we find

$$P = \frac{1}{m} P_1.$$

Hence the fractional error of any integral or fractional power of a measured numeric is equal to the fractional error of the given numeric multiplied by the exponent of the power.

If the given function is in the form of a continuous product

$$X = \alpha X_1 \times X_2 \times \cdots \times X_q,$$

$$(80) \text{ becomes } x = \alpha x_1 \times x_2 \times \cdots \times x_q.$$

$$\text{Hence } \frac{\partial F}{\partial x_1} = \alpha x_2 \times x_3 \times \cdots \times x_q,$$

$$\text{and } \frac{1}{x} \frac{\partial F}{\partial x_1} = \frac{1}{x_1}.$$

Hence, by (81),

$$\frac{E^2}{x^2} = \frac{E_1^2}{x_1^2} + \frac{E_2^2}{x_2^2} + \cdots + \frac{E_q^2}{x_q^2},$$

and, if P, P_1, P_2, \dots, P_q represent the fractional errors of the x 's with corresponding subscripts,

$$P^2 = P_1^2 + P_2^2 + \cdots + P_q^2. \quad (83)$$

Combining the above cases we obtain the more general relation

$$X = \alpha X_1^{\pm n_1} \times X_2^{\pm n_2} \times \cdots \times X_q^{\pm n_q},$$

and the corresponding expression for (80) is

$$x = \alpha x_1^{\pm n_1} \times x_2^{\pm n_2} \times \cdots \times x_q^{\pm n_q}.$$

Applying (82) to each factor separately and then applying (83) to the product, we find

$$P^2 = n_1^2 P_1^2 + n_2^2 P_2^2 + n_3^2 P_3^2 + \cdots + n_q^2 P_q^2. \quad (84)$$

For the sake of illustration and to fix the ideas this result may be compared with the example of the preceding article. If we put $x = V$, $x_1 = D$, $n_1 = 2$, $x_2 = L$, $n_2 = 1$, $\alpha = \frac{\pi}{4}$, $P = P_V$, $P_1 = P_D$, and $P_2 = P_L$ the above expression for x becomes

$$V = \frac{1}{4}\pi D^2 L,$$

and (84) becomes

$$P_V^2 = 4 P_D^2 + P_L^2.$$

Occasionally it is convenient to express the probable error in the form of a percentage of the measured magnitude. If E and p are respectively the probable and percentage errors of x ,

$$p = 100 \frac{E}{x} = 100 P. \quad (85)$$

Consequently (84) may be written in the form

$$p^2 = n_1^2 p_1^2 + n_2^2 p_2^2 + \dots + n_q^2 p_q^2, \quad (84a)$$

where p_1, p_2, \dots, p_q are the percentage errors of x_1, x_2, \dots, x_q , respectively

CHAPTER IX.

ERRORS OF ADJUSTED MEASUREMENTS.

WHEN the most probable values of a number of numerics $X_1, X_2, \text{etc.}$, are determined by the method of least squares, the results $x_1, x_2, \text{etc.}$, are called adjusted measurements of the quantities represented by the X 's. In Chapter VII we have seen how the x 's come out by the solution of the normal equations (56) or (58), and how these equations are derived from the given observations through the equations (53). In the present chapter we will determine the characteristic errors of the computed x 's in terms of the corresponding errors of the direct measurements on which they depend.

63. Weights of Adjusted Measurements. — When there are q unknowns and the given observations are all of the same weight, the normal equations, derived in article fifty, are

$$\left. \begin{aligned} [aa] x_1 + [ab] x_2 + [ac] x_3 + \dots + [ap] x_q &= [as], \\ [ab] x_1 + [bb] x_2 + [bc] x_3 + \dots + [bp] x_q &= [bs], \\ \dots &\dots \\ [ap] x_1 + [bp] x_2 + [cp] x_3 + \dots + [pp] x_q &= [ps]. \end{aligned} \right\} \quad (56)$$

Since these equations are independent, the resulting values of the x 's will be the same whatever method of solution is adopted. In Chapter VII Gauss's method of substitution was used on account of the numerous checks it provides. For our present purpose the method of indeterminate multipliers is more convenient as it gives us a direct expression for the x 's in terms of the measured s 's. Obviously this change of method cannot affect the errors of the computed quantities.

Multiply each of equations (56) in order by one of the arbitrary quantities A_1, A_2, \dots, A_q and add the products. The resulting equation is

$$\left. \begin{aligned} ([aa] A_1 + [ab] A_2 + \dots + [ap] A_q) x_1 \\ + ([ab] A_1 + [bb] A_2 + \dots + [bp] A_q) x_2 \\ + \dots \\ + ([ap] A_1 + [bp] A_2 + \dots + [pp] A_q) x_q \\ = [as] A_1 + [bs] A_2 + \dots + [ps] A_q. \end{aligned} \right\} \quad (86)$$

since the ratio of the mean errors of two quantities is equal to the ratio of their probable errors.

Comparing equations (88) and (89), with the aid of equations (55), article fifty, we see that

$$\left. \begin{aligned} \alpha_1 &= a_1A_1 + b_1A_2 + \dots + p_1A_q, \\ \alpha_2 &= a_2A_1 + b_2A_2 + \dots + p_2A_q, \\ &\cdot \quad \cdot \quad \cdot \quad \cdot \quad \cdot \quad \cdot \quad \cdot \\ \alpha_n &= a_nA_1 + b_nA_2 + \dots + p_nA_q. \end{aligned} \right\} \quad (i)$$

Multiply each of these equations by its a and add the products, then multiply each by its b and add, and so on until all of the coefficients have been used as multipliers. We thus obtain the q sums $[a\alpha]$, $[b\alpha]$, . . . , $[p\alpha]$, and by taking account of equations (87) we have

$$\left. \begin{aligned} [a\alpha] &= 1, \\ [b\alpha] &= [c\alpha] = \dots = [p\alpha] = 0. \end{aligned} \right\} \quad (ii)$$

Hence, if we multiply each of equations (i) by its α and add the products, we have

$$[a\alpha] = A_1.$$

Consequently equation (90) becomes

$$w_1 = \frac{M_s^2}{M_1^2} = \frac{1}{A_1}. \quad (91)$$

The weights of the other x 's may be obtained, by an exactly similar process, from equations (88a). The results of such an analysis are as follows:

$$\left. \begin{aligned} w_2 &= \frac{M_s^2}{M_2^2} = \frac{1}{B_2}, \\ w_3 &= \frac{M_s^2}{M_3^2} = \frac{1}{C_3}, \\ &\cdot \quad \cdot \quad \cdot \quad \cdot \quad \cdot \\ w_q &= \frac{M_s^2}{M_q^2} = \frac{1}{P_q}. \end{aligned} \right\} \quad (91a)$$

Obviously the coefficients of the sums $[as]$, $[bs]$, etc., in equations (88) and (88a) do not depend upon the particular method by which the normal equations are solved, since the resulting values of the x 's must be the same whatever method is used. Consequently, if the absolute terms $[as]$, $[bs]$, . . . , $[ps]$ are kept in literal form during the solution of the normal equations by any method whatever, the results may be written in the form of equations

These equations are in the same form as the normal equations (56) with the x 's replaced by u 's and the s 's by Δ 's. Hence any solution of (56) for the x 's may be transposed into a solution of (viii) for the u 's by replacing the s 's by Δ 's without changing the coefficients of the s 's. Consequently, by (89), we have

$$u_1 = \alpha_1 \Delta_1 + \alpha_2 \Delta_2 + \dots + \alpha_n \Delta_n,$$

and similar expressions for the other u 's.

The coefficients of the u 's in (vii) expand in the form

$$[a\Delta] = a_1 \Delta_1 + a_2 \Delta_2 + \dots + a_n \Delta_n.$$

Hence

$$[a\Delta] u_1 = a_1 \alpha_1 \Delta_1^2 + a_2 \alpha_2 \Delta_2^2 + \dots + a_n \alpha_n \Delta_n^2, \\ + (a_1 \alpha_2 + a_2 \alpha_1) \Delta_1 \Delta_2 + \dots + (a_1 \alpha_n + a_n \alpha_1) \Delta_1 \Delta_n + \dots$$

Since positive and negative Δ 's are equally likely to occur, the sum of the terms involving products of Δ 's with different subscripts will be negligible in comparison with the other terms. The sum of the remaining terms cannot be exactly evaluated, but a sufficiently close approximation is obtained by placing each of the Δ 's equal to the mean square of all of them, $\frac{[\Delta\Delta]}{n}$. Consequently, as the best approximation that we can make, we may put

$$[a\Delta] u_1 = [a\alpha] \frac{[\Delta\Delta]}{n}.$$

But, by equations (ii), $[a\alpha]$ is equal to unity. Hence

$$[a\Delta] u_1 = \frac{[\Delta\Delta]}{n}.$$

Since there is nothing in the foregoing argument that depends on the particular u chosen, the same result would have been obtained with any other u . Consequently, in equation (vii), each term that involves one of the u 's must be equal to $\frac{[\Delta\Delta]}{n}$, and, since there are q such terms, the equation becomes

$$[rr] + q \frac{[\Delta\Delta]}{n} = [\Delta\Delta].$$

Hence, by equation (iii),

$$nM_s^2 = [rr] + qM_s^2,$$

and

$$M_s = \sqrt{\frac{[rr]}{n - q}}, \quad (92)$$

where the r 's represent the residuals, computed by equations (54); n is the number of observations ; and q is the number of unknowns involved in the observation equations (53). In the case of direct measurements, the number of unknowns is one, and (92) reduces to the form already found in article forty-one, equation (30), for the mean error of a single observation.

When the observations are not of equal weight, the mean error M_s of a standard observation, i.e. an observation of weight unity, is given by the expression

$$M_s^2 = \frac{w_1\Delta_1^2 + w_2\Delta_2^2 + \dots + w_n\Delta_n^2}{n} = \frac{[w\Delta\Delta]}{n},$$

where the w 's are the weights of the individual observations. Starting with this relation in place of (iii) and making corresponding changes in other equations, an analysis essentially like the preceding leads to the result

$$M_s = \sqrt{\frac{[wrr]}{n - q}}, \tag{93}$$

which reduces to the same form as (92) when the weights are all unity.

Introducing the constant relation between the mean and probable errors, we have the expressions

$$E_s = 0.674\sqrt{\frac{[rr]}{n - q}}, \tag{94}$$

for the probable error of a single observation in the case of equal weights, and

$$E_s = 0.674\sqrt{\frac{[wrr]}{n - q}}, \tag{95}$$

for the probable error of a standard observation in the case of different weights.

Finally, if M_k , E_k , and w_k represent the mean error, the probable error, and the weight of x_k , any one of the unknown quantities, we may derive the following relations from the above equations by applying equations (36), article forty-four:

$$\left. \begin{aligned} M_k &= \frac{M_s}{\sqrt{w_k}} = \frac{1}{\sqrt{w_k}} \sqrt{\frac{[rr]}{n - q}}, \\ E_k &= \frac{E_s}{\sqrt{w_k}} = \frac{0.674}{\sqrt{w_k}} \sqrt{\frac{[rr]}{n - q}}, \end{aligned} \right\} \tag{96}$$

when the weights of the given observations are equal, and

$$\left. \begin{aligned} M_k &= \frac{M_s}{\sqrt{w_k}} = \frac{1}{\sqrt{w_k}} \sqrt{\frac{[wrr]}{n-q}}, \\ E_k &= \frac{E_s}{\sqrt{w_k}} = \frac{0.674}{\sqrt{w_k}} \sqrt{\frac{[wrr]}{n-q}}, \end{aligned} \right\} \quad (97)$$

when the weights of the given observations are not equal.

65. Application to Problems Involving Two Unknowns.—When the observation equations involve only two unknown quantities, the solution of the normal equations is given by (59), article fifty-one, in the form

$$\begin{aligned} x_1 &= \frac{[bb][as] - [ab][bs]}{[aa][bb] - [ab]^2}, \\ x_2 &= \frac{[aa][bs] - [ab][as]}{[aa][bb] - [ab]^2}. \end{aligned}$$

By the rule of article sixty-three, the weight of x_1 is equal to the reciprocal of the coefficient of $[as]$ in the equation for x_1 , and the weight of x_2 is equal to the reciprocal of the coefficient of $[bs]$ in the equation for x_2 . Hence, by inspection of the above equations, we have

$$\left. \begin{aligned} w_1 &= \frac{[aa][bb] - [ab]^2}{[bb]}, \\ w_2 &= \frac{[aa][bb] - [ab]^2}{[aa]}. \end{aligned} \right\} \quad (98)$$

Since there are only two unknown quantities, and the observations are of equal weight, equation (92) gives the mean error of a single observation when q is taken equal to two. Hence

$$M_s = \sqrt{\frac{[rr]}{n-2}}, \quad (99)$$

where n is the number of observation equations and $[rr]$ is the sum of the squares of the residuals that are obtained when the computed values of x_1 and x_2 are substituted in equations (53a), article fifty-one.

Combining equations (98) and (99) with (96), we obtain the following expressions for the probable errors of x_1 and x_2 :

$$\left. \begin{aligned} E_1 &= 0.674 \sqrt{\frac{[bb]}{[aa][bb] - [ab]^2} \cdot \frac{[rr]}{n-2}}, \\ E_2 &= 0.674 \sqrt{\frac{[aa]}{[aa][bb] - [ab]^2} \cdot \frac{[rr]}{n-2}}. \end{aligned} \right\} \quad (100)$$

For the purpose of illustration, we will compute the probable errors of the values of x_1 and x_2 obtained in the numerical problem worked out in article fifty-one. Referring to the numerical tables in that article, we find

$$[aa] = 5; \quad [ab] = 20; \quad [bb] = 90; \quad n = 5;$$

$$[rr] = 9.60 \times 10^{-4}.$$

Hence, by equations (100),

$$E_1 = 0.674 \sqrt{\frac{90}{5 \times 90 - 400} \cdot \frac{9.60 \times 10^{-4}}{5 - 2}} = \pm 0.016,$$

$$E_2 = 0.674 \sqrt{\frac{5}{5 \times 90 - 400} \cdot \frac{9.60 \times 10^{-4}}{5 - 2}} = \pm 0.0038.$$

By equations (vi), article fifty-one, the length L_0 of the bar at 0°C. , and the coefficient of linear expansion α are given by the relations

$$L_0 = 1000 + x_1; \quad \alpha = \frac{1}{10} \cdot \frac{x_2}{L_0}.$$

Since L_0 is equal to x_1 plus a constant, its probable error is equal to that of x_1 by the argument underlying equation (ii), article sixty. Hence

$$E_{L_0} = E_1 = \pm 0.016.$$

To find the probable error of α , we have by equations (81), article sixty,

$$E_\alpha^2 = \left(\frac{\partial \alpha}{\partial x_2} E_2\right)^2 + \left(\frac{\partial \alpha}{\partial L_0} E_{L_0}\right)^2$$

$$= \left(\frac{1}{10} \cdot \frac{1}{L_0}\right)^2 E_2^2 + \left(-\frac{1}{10} \frac{x_2}{L_0^2}\right)^2 E_{L_0}^2.$$

But, since L_0 is very large in comparison with x_2 , the second term on the right-hand side is negligible in comparison with the first. Consequently, without affecting the second significant figure of the result, we may put

$$E_\alpha = \frac{1}{10} \cdot \frac{1}{L_0} E_2$$

$$= E_2 \times 10^{-4} = \pm 0.038 \times 10^{-5}.$$

Hence the final results of the computations in article fifty-one may be more comprehensively expressed in the form

$$L_0 = 1000.008 \pm 0.016 \text{ millimeters,}$$

$$\alpha = (1.780 \pm 0.038) \times 10^{-5},$$

when we wish to indicate the precision of the observations on which they depend.

66. Application to Problems Involving Three Unknowns.—The normal equations, for the determination of three unknowns, take the form

$$\begin{aligned} [aa] x_1 + [ab] x_2 + [ac] x_3 &= [as], \\ [ab] x_1 + [bb] x_2 + [bc] x_3 &= [bs], \\ [ac] x_1 + [bc] x_2 + [cc] x_3 &= [cs]. \end{aligned}$$

Solving by the method of determinants and putting

$$\begin{vmatrix} [aa] & [ab] & [ac] \\ [ab] & [bb] & [bc] \\ [ac] & [bc] & [cc] \end{vmatrix} = D,$$

we have

$$\left. \begin{aligned} x_1 &= [as] \frac{\begin{vmatrix} [bb] & [bc] \\ [bc] & [cc] \end{vmatrix}}{D} + [bs] \frac{\begin{vmatrix} [bc] & [cc] \\ [ab] & [ac] \end{vmatrix}}{D} + [cs] \frac{\begin{vmatrix} [ab] & [ac] \\ [bb] & [bc] \end{vmatrix}}{D}, \\ x_2 &= [as] \frac{\begin{vmatrix} [ac] & [cc] \\ [ab] & [bc] \end{vmatrix}}{D} + [bs] \frac{\begin{vmatrix} [aa] & [ac] \\ [ac] & [cc] \end{vmatrix}}{D} + [cs] \frac{\begin{vmatrix} [ab] & [bc] \\ [aa] & [ac] \end{vmatrix}}{D}, \\ x_3 &= [as] \frac{\begin{vmatrix} [ab] & [bb] \\ [ac] & [bc] \end{vmatrix}}{D} + [bs] \frac{\begin{vmatrix} [ac] & [bc] \\ [aa] & [ab] \end{vmatrix}}{D} + [cs] \frac{\begin{vmatrix} [aa] & [ab] \\ [ab] & [bb] \end{vmatrix}}{D}. \end{aligned} \right\} \quad (\text{ix})$$

Hence, by the rule of article sixty-three,

$$\left. \begin{aligned} w_1 &= \frac{D}{[bb][cc] - [bc]^2}, \\ w_2 &= \frac{D}{[aa][cc] - [ac]^2}, \\ w_3 &= \frac{D}{[aa][bb] - [ab]^2}. \end{aligned} \right\} \quad (\text{x})$$

The determinant D can be eliminated from equations (x), if we can obtain an independent expression for any one of the w 's. The solution of the normal equations by Gauss's Method in article fifty-four led to the result

$$x_3 = \frac{[cs \cdot 2]}{[cc \cdot 2]}.$$

The auxiliary $[cc \cdot 2]$ is independent of the absolute terms $[as]$, $[bs]$, and $[cs]$. The auxiliary $[cs \cdot 2]$ may be expanded as follows:

$$\begin{aligned}
 [cs \cdot 2] &= [cs \cdot 1] - \frac{[bc \cdot 1]}{[bb \cdot 1]} [bs \cdot 1] \\
 &= [cs] - \frac{[ac]}{[aa]} [as] - \frac{[bc \cdot 1]}{[bb \cdot 1]} \left\{ [bs] - \frac{[ab]}{[aa]} [as] \right\}.
 \end{aligned}$$

Hence the coefficient of $[cs]$ in the above expression for x_3 is $\frac{1}{[cc \cdot 2]}$, and, consequently, the weight of x_3 is equal to $[cc \cdot 2]$. Substituting this value for w_3 in the third of equations (x) and eliminating D from the other two we have

$$\left. \begin{aligned}
 w_1 &= \frac{[aa][bb \cdot 1]}{[bb][cc] - [bc]^2} [cc \cdot 2], \\
 w_2 &= \frac{[bb \cdot 1]}{[cc \cdot 1]} [cc \cdot 2], \\
 w_3 &= [cc \cdot 2],
 \end{aligned} \right\} \quad (101)$$

where the auxiliary quantities $[bb \cdot 1]$, $[cc \cdot 1]$, and $[cc \cdot 2]$ have the same significance as in article fifty-four.

The weights of the x 's having been determined by equations (101), their probable errors may be computed by equations (96). In the present case q is taken equal to three, since there are three unknowns, and the r 's are given by equations (68).

In the numerical illustration of Gauss's Method, worked out in article fifty-five, we found the following values of the quantities appearing in equations (96) and (101):

$$\begin{aligned}
 [aa] &= 6; [bb] = 220; [bc] = 180; [cc] = 157; \\
 [bb \cdot 1] &= 70; [cc \cdot 1] = 76.0; [cc \cdot 2] = 5.97; \\
 [rr] &= 0.00120; n = 6; q = 3.
 \end{aligned}$$

These values have been rounded to three significant figures, when necessary, since the probable errors of the x 's are desired to only two significant figures. Substituting in equations (101) we have

$$\begin{aligned}
 w_1 &= \frac{6 \times 70}{220 \times 157 - 180^2} 5.97 = 1.17, \\
 w_2 &= \frac{70}{76.0} 5.97 = 5.50, \\
 w_3 &= 5.97.
 \end{aligned}$$

From equation (94)

$$E_s = 0.674 \sqrt{\frac{0.0012}{6-3}} = \pm 0.0135,$$

and, by equations (96),

$$E_1 = \frac{0.0135}{\sqrt{1.17}} = \pm 0.012,$$

$$E_2 = \frac{0.0135}{\sqrt{5.50}} = \pm 0.0057,$$

$$E_3 = \frac{0.0135}{\sqrt{5.97}} = \pm 0.0055.$$

Consequently the precision of the measurements, so far as it depends on accidental errors, may be expressed by writing the computed values of the x 's in the form

$$x_1 = 0.245 \pm 0.012,$$

$$x_2 = -1.0003 \pm 0.0057,$$

$$x_3 = 1.4022 \pm 0.0055.$$

Since the last significant figure in each of the x 's occupies the same place as the second significant figure in the corresponding probable error, it is evident that the proper number of figures were retained throughout the computations in article fifty-five.

CHAPTER X.

DISCUSSION OF COMPLETED OBSERVATIONS.

67. Removal of Constant Errors. — The discussion of accidental errors and the determination of their effect on the result computed from a given series of observations, as carried out in the preceding chapters, are based on the assumption that the measurements are entirely free from constant errors and mistakes. Hence the first matter of importance, in undertaking the reduction of observations, is the determination and removal of all constant errors and mistakes. Also, in criticizing published or reported results, judgment is based very largely on the skill and care with which such errors have been treated. In the former case, if suitable methods and apparatus have been chosen and the adjustments of instruments have been properly made, sufficient data is usually at hand for determining the necessary corrections within the accidental errors. In the latter case we must rely on the discussion of methods, apparatus, and adjustments given by the author and very little weight should be given to the reported measurements if this discussion is not clear and adequate.

No evidence can be obtained from the observations themselves regarding the presence or absence of strictly constant errors. The majority of them are due to inexact graduation of scales, imperfect adjustment of instruments, personal peculiarities of the observer, and faulty methods of manipulation. They affect all of the observations by the same relative amount. Their detection and correction or elimination depend entirely on the judgment, experience, and care of the observer and the computer. When the same magnitude has been measured by a number of different observers, using different methods and apparatus, the probability that the constant errors have been the same in all of the measurements is very small. Consequently if the corrected results agree, within the accidental errors of observation, it is highly probable that they are free from constant errors. This is the only criterion we have for the absence of such errors and it

the result will be the same as if the corrected observations had been used; and, as pointed out above, the observations and their corresponding residuals give no evidence of the presence of strictly constant errors.

When the constant errors affecting the different observations are different or when any of them are systematic in character, equation (iv) no longer holds, and, consequently, the simplification expressed by (102) is no longer possible. In the former case the observations should be individually corrected before the mean is taken. The same result might be obtained from equation (iii), but the computation would not be simplified by its use. In the latter case the several observations are affected by errors due to the same causes but varying progressively in magnitude in response to more or less continuous variations in the conditions under which they are made.

In equations (ii) the c 's having the same index may be considered to be due to the same cause, but to vary in magnitude from equation to equation as indicated by the subscripts. The arithmetical means of the errors due to the same causes are

$$c_m' = \frac{c_1' + c_2' + \dots + c_n'}{n},$$

$$c_m'' = \frac{c_1'' + c_2'' + \dots + c_n''}{n},$$

$$\dots$$

$$c_m^{(q)} = \frac{c_1^{(q)} + c_2^{(q)} + \dots + c_n^{(q)}}{n},$$

and the mean of the observations is

$$o_m = \frac{o_1 + o_2 + \dots + o_n}{n}.$$

Substituting (ii) in (i) and taking account of the above relations we have

$$x = o_m + c_m' + c_m'' + \dots + c_m^{(q)}. \quad (104)$$

Hence, in the case of systematic errors, the most probable value of the numeric of the measured magnitude may be obtained from the mean of the uncorrected observations by applying mean corrections for the systematic errors. When all of the errors are strictly constant equation (104) becomes identical with (102) because all of the errors having the same index are equal. Obvi-

ously it also holds when part of the c 's are strictly constant and the remainder are systematic.

If we use the value of x given by (104) in place of that given by (102) in the residual equations (103), the c 's will not cancel. Hence, if any of the constant errors are systematic in nature, the residuals computed from the o 's and o_m will be different from those computed from the a 's and x ; and, consequently, they will not be distributed in accordance with the law of accidental errors.

In practice it is generally advisable to correct each of the observations separately before taking the mean rather than to use equation (104), since the true residuals are required in computing the probable error of x , and they cannot be derived from the uncorrected observations. Whenever possible the conditions should be so chosen that systematic errors are avoided and then the necessary computation can be made by equations (102) and (103).

68. Criteria of Accidental Errors. — We have seen that the residuals computed from observations affected by systematic errors do not follow the law of accidental errors. Hence, if it can be shown that the residuals computed from any given series of observations are distributed in conformity with the law of errors, it is probable that the given observations are free from systematic errors or that such errors are negligible in comparison with the accidental errors. Observations that satisfy this condition may or may not be free from strictly constant errors, but necessary corrections can be made by equation (102) and the probable error of the mean may be computed from the residuals given by equation (103).

Systematic errors should be very carefully guarded against in making the observations, and the conditions that produce them should be constantly watched and recorded during the progress of the work. After the observations have been completed they should be individually corrected for all known systematic errors before taking the mean. The strictly constant errors may then be removed from the mean, but before this is done it is well to compute the residuals and see if they satisfy the law of accidental errors. If they do not, search must be made for further causes of systematic error in the conditions surrounding the measurements and a new series of observations should be made, under more favorable conditions, whenever sufficient data for this purpose is not available.

Residuals, when sufficiently numerous, follow the same law of distribution as the true accidental errors. Consequently systematic errors and mistakes might be detected by a direct comparison of the actual distribution with the theoretical, as carried out in article thirty-four, provided the number of observations is very large. However, in most practical measurements, the residuals are not sufficiently numerous to fulfill the conditions underlying the law of errors, and a considerable difference between their actual and theoretical distribution is quite as likely to be due to this fact as to the presence of systematic errors. Whatever the number of observations, a close agreement between theory and practice is strong evidence of the absence of such errors but it is seldom worth while to carry out the comparison with less than one hundred residuals.

When the residuals are numerous and distributed in the same manner as the accidental errors, the average error of a single observation, computed by the formula

$$A = \frac{[\bar{r}]}{\sqrt{n(n-1)}},$$

and the mean error, computed by the formula

$$M = \sqrt{\frac{[rr]}{n-1}},$$

satisfy the relation

$$M = 1.253 A.$$

Also the formulæ

$$E = 0.8453 A \quad \text{and} \quad E = 0.6745 M$$

give the same value for the probable error of a single observation. When the number of observations is limited, exact fulfillment of these relations ought not to be expected, but a large deviation from them is strong evidence of the presence of systematic errors or mistakes. Unless the number of observations is very small, ten or less, the relations should be fulfilled within a few units in the second significant figure, as is the case in the numerical example worked out in article forty-two.

Obviously the arithmetical mean is independent of the order in which the observations are arranged in taking it, but the order of the residuals in regard to sign and magnitude depends on the order of the observations. When there are systematic errors and the observations are arranged in the order of progression of their

cause, the residuals will gradually increase or decrease in absolute magnitude in the same order; and, if the systematic errors are large in comparison with the accidental errors, there will be but one change of sign in the series. Thus, if the temperature is gradually rising while a length is being measured with a metallic scale and the observations are arranged in the order in which they are taken, the first half of them will be larger than the mean and the last half smaller, except for the variations caused by accidental errors. For the purpose of illustration, suppose that the observations are

1001.0; 1000.9; 1000.8; 1000.7; 1000.6; 1000.5; 1000.4.
The mean is 1000.7 and the residuals

$$+ .3; + .2; + .1; \pm .0; - .1; - .2; - .3$$

decrease in absolute magnitude from left to right, i.e., in the order in which the observations were made. There are five cases in which the signs of succeeding residuals are alike and one in which they are different; the former cases will be called *sign-follows* and the latter a *sign-change*. This order of the residuals in regard to magnitude and sign is typical of observations affected by systematic errors when they are arranged in conformity with the changes in surrounding conditions. Since such changes are usually continuous functions of the time, the required arrangement is generally the order in which the observations are taken.

Such extreme cases as that illustrated above are seldom met with in practice owing to the impossibility of avoiding accidental errors of observation and the complications they produce in the sequence of residuals. Generally the systematic errors that are not readily discovered and corrected before making further reductions are comparable in magnitude with the accidental errors. Consequently they cannot control the sequence in the signs of the residuals but they do modify the sequence characteristic of true accidental errors.

In any extended series of observations there should be as many negative residuals as positive ones, since positive and negative errors are equally likely to occur. After any number of observations have been made, the probability that the residual of the next observation will be positive is equal to the probability that it will be negative, since the possible number of either positive or negative errors is infinite. Consequently the chance that succeeding residuals

will have the same sign is equal to the chance that they will have different signs. Hence, if the residuals are arranged in the order in which the corresponding observations were made, the number of sign-follows should be equal to the number of sign-changes.

The residuals, computed from limited series of observations, seldom exhibit the theoretical sequence of signs exactly because they are not sufficiently numerous to fulfill the underlying conditions. Nevertheless, a marked departure from that sequence suggests the presence of systematic errors or mistakes and should lead to a careful scrutiny of the observations and the conditions under which they were made. If the disturbing causes cannot be detected and their effects eliminated, it is generally advisable to repeat the observations under more favorable conditions. The numerical example, worked out in article forty-two, may be cited as an illustration from practice. The observations were made in the order in which they are tabulated, beginning at the top of the first column and ending at the bottom of the fourth column. In the second and fifth columns we find ten positive and ten negative residuals. The number of sign-follows is ten and the number of sign-changes is nine. This is rather better agreement with the theoretical sequence of signs than is usually obtained with so few residuals. It indicates that the observations were made under favorable conditions and are sensibly free from systematic errors but it gives no evidence whatever that strictly constant errors are absent.

Although the foregoing criteria of accidental errors are only approximately fulfilled when the number of observations is limited, their application frequently leads to the detection and elimination of unforeseen systematic errors. The first method is rather tedious and of little value when less than one hundred observations are considered, but the last two methods may be easily carried out and are generally exact enough for the detection of systematic errors comparable in magnitude with the probable error of a single observation.

69. Probability of Large Residuals. — In discussing the distribution of residuals in regard to magnitude, the words large and small are used in a comparative sense. A large residual is one that is large in comparison with the majority of residuals in the series considered. Thus, a residual that would be classed as large in a series of very precise observations would be considered small in

dealing with less exact observations. Consequently, in expressing the relative magnitudes of residuals, it is customary to adopt a unit that depends on the precision of the measurements considered. The probable error of a single observation is the best magnitude to adopt for this purpose, since it is greater than one-half of the errors and less than the other half. If we represent the relative magnitude of a given error by S , the actual magnitude by Δ , and the probable error of a single observation by E ,

$$S = \frac{\Delta}{E}. \quad (105)$$

The relative magnitudes of the residuals may be represented in the same way by replacing the error Δ by the residual r . It is obvious that values of S less than unity correspond to small residuals and values greater than unity to large residuals in any series of observations.

In equation (13), article thirty-three, the probability that an error chosen at random is less than a given error Δ is expressed by the integral

$$P_{\Delta} = \frac{2}{\sqrt{\pi}} \int_0^{\sqrt{\pi} \frac{\omega}{k} \Delta} e^{-t^2} dt. \quad (13)$$

Equation (25), article thirty-eight, may be put in the form

$$E = \frac{\beta}{\sqrt{\pi}} \cdot \frac{k}{\omega},$$

where β is written for the numerical constant 0.47694. Hence, introducing (105),

$$\sqrt{\pi} \frac{\omega}{k} = \frac{\beta}{E} = \frac{\beta S}{\Delta},$$

and (13) becomes

$$P_s = \frac{2}{\sqrt{\pi}} \int_0^{\beta S} e^{-t^2} dt. \quad (106)$$

Obviously this integral expresses the probability that an error chosen at random is less than S times the probable error of a single observation. It is independent of the particular series to which the observations belong and its values, corresponding to a series of values of the argument S , are given in Table XII.

Since all of the errors in any system are less than infinity, P_{∞} is equal to unity. Hence the probability that a single error,

chosen at random, is greater than S times E is given by the relation

$$Q_s = 1 - P_s. \quad (v)$$

Now the residuals, when sufficiently numerous and free from systematic errors and mistakes, should follow the same distribution as the accidental errors. Hence, if n_s is the number of residuals numerically greater than SE and N is the total number in any series of observations, we should have

$$Q_s = \frac{n_s}{N}. \quad (vi)$$

Since the numerical value of P_s , and consequently that of Q_s depends only on the limit S and is independent of the precision of the particular series of measurements considered, the ratio $\frac{n_s}{N}$, corresponding to any given limit S , should be the same in all cases. Consequently, if N observations have been made on any magnitude and by any method whatever, n_s of them should correspond to residuals numerically greater than SE . Conversely, if we assign any arbitrary number to n_s , equation (vi) defines the number of observations that we should expect to make without exceeding the assigned number of residuals greater than SE . Hence, if N_s is the number of observations among which there should be only one residual greater than S times the probable error of a single observation, we have, by placing n_s equal to one in (vi), and substituting the value of Q_s from (v),

$$N_s = \frac{1}{Q_s} = \frac{1}{1 - P_s}. \quad (107)$$

The fourth column of the following table gives the values of N_s , to the nearest integer, corresponding to the integral values of the limit S given in the first column. The values of P_s in the second column are taken from Table XII, and those of Q_s in the third column are computed by equation (v).

S	P_s	Q_s	N_s
1	0.50000	0.50000	2
2	0.82266	0.17734	6
3	0.95698	0.04302	23
4	0.99302	0.00698	143
5	0.99926	0.00074	1351

To illustrate the significance of this table, suppose that 143 direct observations have been made on any magnitude by any method whatever. The probable error E of a single observation in this series may be computed from the residuals by equation (31) or (34). Then, if the residuals follow the law of errors, not more than one of them should be greater than four times as large as E . If the number of observations had been 1351, we should expect to find one residual greater than five times E , and on the other hand if the number had been only twenty-three, not more than one residual should be greater than three times E .

Although the probability for the occurrence of large residuals is small, and very few of them should occur in limited series of observations, their distribution among the observations, in respect to the order in which they occur, is entirely fortuitous. A large residual is as likely to occur in the first, or any other, observation of an extended series as in the last observation. Consequently the limited series of observations, taken in practice, frequently contain abnormally large residuals. This is not due to a departure from the law of errors, but to a lack of sufficient observations to fulfill the theoretical conditions. In such cases there are not enough observations with normal residuals to balance those with abnormally large ones. Consequently a closer approximation to the arithmetical mean that would have been obtained with a more extended series of observations is obtained when the abnormal observations are rejected from the series before taking the mean.

Observations should not be rejected simply because they show large residuals, unless it can be shown that the limit set by the theory of errors, for the number of observations considered, is exceeded. This can be judged approximately by comparing the residuals of the given observations with the numbers given in the first and last columns of the above table, but a more rigorous test is obtained by applying Chauvenet's Criterion, as explained in the following article.

70. Chauvenet's Criterion. — The probability that the error of a single observation, chosen at random, is less than SE is expressed by P_s in equation (106). Now, the taking of N independent observations is equivalent to N selections at random from the infinite number of possible accidental errors. Hence, by equation (7), article twenty-three, the probability that each of

the N observations in any series is affected by an error less than SE is equal to P_s^N . Since all of the N errors must be either greater or less than SE , the probability that at least one of them is greater than this limit is equal to $1 - P_s^N$. Placing this probability equal to one-half, we have

$$1 - P_s^N = \frac{1}{2},$$

or

$$P_s = (1 - \frac{1}{2})^{\frac{1}{N}}. \quad (\text{vii})$$

If the limit S is determined by this equation, there is an even chance that at least one of the N observations is affected by an error greater than SE .

Expanding the second member of (vii) by the Binomial Theorem

$$\begin{aligned} \left(1 - \frac{1}{2}\right)^{\frac{1}{N}} &= 1 - \frac{1}{N} \cdot \frac{1}{2} - \frac{N-1}{1 \cdot 2} \cdot \frac{1}{N^2} \cdot \frac{1}{4} - \frac{(N-1)(2N-1)}{1 \cdot 2 \cdot 3} \cdot \frac{1}{N^3} \cdot \frac{1}{8} - \dots \\ &\dots - \frac{(N-1)(2N-1) \dots \{(K-1)N-1\}}{1 \cdot 2 \cdot 3 \dots K \cdot N^K} \cdot \left(\frac{1}{2}\right)^K. \end{aligned}$$

The terms of this series decrease very rapidly and all but the first are negative. Consequently the sum of the terms beyond the second is small in comparison with the other two; and, whatever the value of N , $(1 - \frac{1}{2})^{\frac{1}{N}}$ is nearly equal to, but always slightly less than, $\frac{(2N-1)}{2N}$. Since P_s and S increase together, the limit T determined by the relation

$$P_T = \frac{2N-1}{2N} \quad (108)$$

is slightly greater than the limit S determined by (vii). Hence, if N independent direct observations have been made, the probability against the occurrence of a single error greater than

$$\Delta_T = TE \quad (109)$$

is greater than the probability for its occurrence. Consequently, if the given series contains a residual greater than Δ_T , the probable precision of the arithmetical mean is increased by excluding the corresponding observation.

Equations (108) and (109) express Chauvenet's Criterion for the rejection of doubtful observations. In applying them, the probable error E of a single observation is first computed from the residuals of all of the observations by either equation (31) or the first of equations (34) with the aid of Table XIV or XV. If any of the residuals appear large in comparison with the computed value of E , P_T is determined from (108) by placing N equal to the number of observations in the given series. T is then obtained by interpolation from Table XII, and finally Δ_T is computed by (109). If one or more of the residuals are greater than the computed Δ_T , the observation corresponding to the largest of them is excluded from the series and the process of applying the criterion is repeated from the beginning. If one or more of the new residuals are greater than the new value of Δ_T , the observation corresponding to the largest of them is rejected. This process is repeated and observations rejected one at a time until a value of Δ_T is obtained that is greater than any of the residuals.

When more than one residual is greater than the computed value of Δ_T , only the observation corresponding to the largest of them should be rejected without further study. The rejection of a single observation from the given series changes the arithmetical mean, and hence all of the residuals and the value of E computed from them. If r and r' are the residuals corresponding to the same observation before and after the rejection of a more faulty observation, and if Δ_T and Δ_T' are the corresponding limiting errors, it may happen that r' is less than Δ_T' , although r is greater than Δ_T . Hence the second application of the criterion may show that a given observation should be retained notwithstanding the fact that its residual was greater than the limiting error in the first application, provided an observation with a larger residual was excluded on the first trial.

To facilitate the computation of Δ_T , the values of T corresponding to a number of different values of N have been interpolated from Table XII and entered in the second column of Table XIII.

For the purpose of illustration, suppose that ten micrometer settings have been made on the same mark and recorded, to the nearest tenth of a division of the micrometer head, as in the first column of the following table.

Obs.	r	r'
2.567	+0.0118	
2.559	+0.0038	+0.0051
2.556	+0.0008	+0.0021
2.552	-0.0032	-0.0019
2.551	-0.0042	-0.0029
2.553	-0.0022	-0.0009
2.555	-0.0002	+0.0011
2.548	-0.0072	-0.0059
2.554	-0.0012	+0.0001
2.557	+0.0018	+0.0031
$x = 2.5552$ $x' = 2.5539$	$[\bar{r}] = 0.0364$ $E = 0.0032$ $T = 2.91$ $\Delta T = 0.0093$	$[\bar{r}'] = 0.0231$ $E' = 0.0023$ $T' = 2.84$ $\Delta T' = 0.0065$

The residuals, computed from the mean x , are given under r . The probable error E , computed from $[\bar{r}]$ by the first of equations (34), with the aid of Table XV, is 0.0032. The value of T corresponding to ten observations is 2.91 from Table XIII, and the limiting error ΔT is equal to 0.0093. Since this is less than the residual 0.0118, the corresponding observation (2.567) should be rejected from the series.

The mean of the retained observations, x_1' , is 2.5539, and the corresponding residuals are given under r' in the third column of the above table. The new value of the limiting error ($\Delta T'$), computed by the same method as above, is 0.0065. Since none of the new residuals are larger than this, the nine observations left by the first application of the criterion should all be retained.

71. Precision of Direct Measurements. — The first step in the reduction of a series of direct observations is the correction of all known systematic errors and the test of the completeness of this process by the criteria of article sixty-eight. In general, the systematic errors represent small variations of otherwise constant errors; and, in making the preliminary corrections, it is best to consider only this variable part, i.e., the corrections are so applied that all of the corrected observations are left with exactly the same constant errors. Thus, suppose that the temperature of a scale is varying slowly during a series of observations, and is never very near to the temperature at which the scale is standard. It is better to correct each observation to the mean temperature of the scale and leave the larger correction, from mean to standard

temperature, until it can be applied to the arithmetical mean in connection with the corrections for other strictly constant errors. This is because the systematic variations in the length of the scale are so small that the unavoidable errors in the observed temperatures and the adopted coefficient of expansion of the scale can produce no appreciable effect on the corrections to mean temperature. The effect of these errors on the larger correction from mean to standard temperature is more simply treated in connection with the arithmetical mean than with the individual observations.

Let o_1, o_2, \dots, o_n represent a series of direct observations corrected for all known systematic errors and satisfying the criteria of accidental errors. We have seen that the most probable value that we can assign to the numeric of the measured magnitude, on the basis of such a series, is given by the relation

$$x = o_m + c' + c'' + \dots + c^{(a)}, \quad (102)$$

where o_m is the arithmetical mean of the o 's, and the c 's represent corrections for strictly constant errors. If the c 's could be determined with absolute accuracy, or even within limiting errors that are negligible in comparison with the accidental errors of the o 's, the only uncertainty in the above expression for x would be that due to the accidental error of o_m . Hence, by equations (103), if E_x and E_m are the probable errors of x and o_m , respectively, we should have

$$E_x = E_m = 0.674 \sqrt{\frac{[rr]}{n(n-1)}}. \quad (110)$$

If we follow the usual practice and regard the probable error of a quantity as a measure of the accidental errors of the observations from which it is directly computed, equation (110) still holds when the accidental errors of the c 's are not negligible; but, as we shall see, E_x is no longer a complete measure of the precision of x in such cases.

In practice each of the c 's must be computed, on theoretical grounds, from subsidiary observations with the aid of physical constants that have been previously determined by direct or indirect measurements. For the sake of brevity the quantities on which the c 's depend will be called *correction factors*. Since all of them are subject to accidental errors, the computed c 's are affected by residual errors of indeterminate sign and magnitude.

When the probable errors of the correction factors are known the probable errors of the c 's may be computed by the laws of propagation of errors with the aid of the correction formulæ by which the c 's are determined.

Equation (102) gives x as a continuous sum of o_m and the c 's. Consequently, if we represent the probable errors of the c 's by E_1, E_2, \dots, E_q , respectively, we have by equation (76), article fifty-eight,

$$R_x^2 = E_m^2 + E_1^2 + \dots + E_q^2, \quad (111)$$

where R_x is the resultant probable error of x due to the corresponding errors of o_m and the c 's. To distinguish R_x from the probable error E_x , which depends only on the accidental error of o_m , we shall call it the *precision measure* of x .

Although equation (111) is simple in form, the separate computation of the E 's, from the errors of the correction factors on which they depend, is frequently a tedious process. Moreover several of the c 's may depend on the same determining quantities. Consequently the computation of x and R_x is frequently facilitated by bringing the correction factors into the equation for x explicitly, rather than allowing them to remain implicit in the c 's. Thus, if $\alpha, \beta, \dots, \rho$ represent the correction factors on which the c 's depend, equation (102) may be put in the form

$$x = F(o_m, \alpha, \beta, \dots, \rho). \quad (112)$$

Hence, by equation (81), article sixty,

$$R_x^2 = \left(\frac{\partial F}{\partial o_m} E_m\right)^2 + \left(\frac{\partial F}{\partial \alpha} E_\alpha\right)^2 + \dots + \left(\frac{\partial F}{\partial \rho} E_\rho\right)^2, \quad (113)$$

where E_α, E_β , etc., are the probable errors of α, β , etc.

For example, suppose that o_m represents the mean of a number of observations of the distance between two parallel lines expressed in terms of the divisions of the scale used in making the measurements. Let t_1 represent the mean temperature of the scale during the observations; L the mean length of the scale divisions at the standard temperature t_0 , in terms of the chosen unit; α the coefficient of expansion of the scale; and β the angle between the scale and the normal to the lines. Then, if the individual observations have been corrected to mean temperature t_1 before computing the mean observation o_m , the best approxima-

tion that we can make to the true distance between the lines is given by the expression

$$x = o_m L \{1 + \alpha(t_1 - t_0)\} \frac{1}{\cos \beta},$$

in which the correction factors L , α , β , t_1 , and t_0 appear explicitly as in the general equation (112). A more detailed discussion of this example will be found in article seventy-three.

If we represent the separate effects of the errors $E_m, E_\alpha, \dots, E_\rho$ on the error R_x by $D_m, D_\alpha, D_\beta, \dots, D_\rho$, respectively, we have

$$D_m = \frac{\partial F}{\partial o_m} E_m; \quad D_\alpha = \frac{\partial F}{\partial \alpha} E_\alpha; \quad \dots; \quad D_\rho = \frac{\partial F}{\partial \rho} E_\rho, \quad (114)$$

and (113) becomes

$$R_x^2 = D_m^2 + D_\alpha^2 + D_\beta^2 + \dots + D_\rho^2. \quad (115)$$

In some cases the fractional effects

$$P_m = \frac{D_m}{x}; \quad P_\alpha = \frac{D_\alpha}{x}; \quad \dots; \quad P_\rho = \frac{D_\rho}{x}$$

can be more easily computed numerically than the corresponding D 's. When this occurs, the fractional precision measure

$$P_x^2 = \frac{R_x^2}{x^2} = P_m^2 + P_\alpha^2 + P_\beta^2 + \dots + P_\rho^2 \quad (116)$$

is first computed and then R_x is determined by the relation

$$R_x = x \cdot P_x. \quad (117)$$

While equations (112) to (117) are apparently more complicated than (102) and (111), they generally lead to more simple numerical computations. Moreover the probable errors of some of the correction factors are frequently so small that they produce no appreciable effect on R_x . When either equation (115) or (116) is used, such cases are easily recognized because the corresponding D 's or P 's are negligible in comparison with D_m or P_m . Obviously the same condition applies to the E 's in equation (111), but the numerical computation of either the D 's or the P 's is generally more simple than that of the E 's in (111) because approximate values of o_m and the correction factors may be used in evaluating the differential coefficients in (114). The allowable degree of approximation, the limit of negligibility of the D 's, and some other

details of the computation will be discussed more extensively in the next article.

If the true numeric of the measured magnitude is represented by X , the final result of a series of direct measurements may be expressed in the form

$$X = x \pm R_x, \quad (118)$$

where x is the most probable value that can be assigned to X on the basis of the given observations, and R_x is the precision measure of x . In practice x may be computed by either equation (102) or (112), or the arithmetical mean of the individually corrected observations may be taken, and R_x is given by equations (111), (115), or (117), the choice of methods depending on the nature of the given data and the preference of the computer.

The exact significance of equation (118) should be carefully borne in mind, and it should be used only when the implied conditions have been fulfilled. Briefly stated, these conditions are as follows:

1st. The accidental errors of the observations on which x depends follow the general law of such errors.

2nd. A careful study of the methods and apparatus used has been made for the purpose of detecting all sources of constant or systematic errors and applying the necessary corrections.

3rd. The given value of x is the most probable that can be computed from the observations after all constant errors, systematic errors, and mistakes have been as completely removed as possible.

4th. The resultant effect of all sources of error, whether accidental errors of observation or residual errors left by the corrections for constant errors, is as likely to be less than R_x as greater than R_x .

The expressions in the form $X = x \pm E_x$, used in preceding chapters, are not violations of the above principles because, in those cases, we were discussing only the effects of accidental errors and the observations were assumed to be free from all constant errors and mistakes. Such ideal conditions never occur in practice. Consequently R_x should not be replaced by E_x in expressing the result of actual measurements in the form of equation (118), unless it can be shown by equation (115), and the given data that the sum of the squares of the D 's corresponding to all of the correction factors is negligible in comparison with D_m^2 .

In the latter case E_x and R_x are identical as may be easily seen by comparing equations (110), (111), and (115).

72. Precision of Derived Measurements. — When a desired numeric X_0 is connected with the numerics X_1, X_2, \dots, X_q of a number of directly measured magnitudes by the relation

$$X_0 = F(X_1, X_2, \dots, X_q),$$

the most probable value that we can assign to X_0 is given by the expression

$$x_0 = F(x_1, x_2, \dots, x_q), \quad (119)$$

where the x 's are the most probable values of the X 's with corresponding subscripts. Each of the component x 's, together with its precision measure, can be computed by the methods of the preceding article. The precision measure of x_0 may be computed with the aid of equation (81), article sixty, by replacing the E 's in that equation by the R 's with corresponding subscripts.

Sometimes the numerical computations are simplified and the discussion is clarified by bringing the direct observations and the correction factors explicitly into the expression for x_0 . If o_a, o_b, \dots, o_p are the arithmetical means of the direct observations, after correction for systematic errors, on which x_1, x_2, \dots, x_q respectively depend, and $\alpha, \beta, \dots, \rho$ are the correction factors involved in the constant errors of the observations, equation (119) may be put in the form

$$x_0 = \theta(o_a, o_b, \dots, o_p, \alpha, \beta, \dots, \rho). \quad (120)$$

The function θ is always determinable when the function F in (119) is given and the correction formulæ for the constant errors are known.

Representing the precision measure of x_0 by R_0 , and adopting an obvious extension of the notation of the preceding article, we have, by equation (81),

$$R_0^2 = \left(\frac{\partial\theta}{\partial o_a} E_a\right)^2 + \dots + \left(\frac{\partial\theta}{\partial o_p} E_p\right)^2 + \left(\frac{\partial\theta}{\partial \alpha} E_\alpha\right)^2 + \dots + \left(\frac{\partial\theta}{\partial \rho} E_\rho\right)^2. \quad (121)$$

Introducing the separate effects of the E 's,

$$D_a = \frac{\partial\theta}{\partial o_a} E_a; \dots; D_p = \frac{\partial\theta}{\partial o_p} E_p; D_\alpha = \frac{\partial\theta}{\partial \alpha} E_\alpha; \dots; D_\rho = \frac{\partial\theta}{\partial \rho} E_\rho, \quad (122)$$

(121) becomes

$$R_0^2 = D_a^2 + D_b^2 + \dots + D_p^2 + D_\alpha^2 + D_\beta^2 + \dots + D_\rho^2. \quad (123)$$

The fractional effects of the E 's are

$$P_a = \frac{D_a}{x_0}; \dots; P_p = \frac{D_p}{x_0}; P_\alpha = \frac{D_\alpha}{x_0}; \dots; P_\rho = \frac{D_\rho}{x_0},$$

and the fractional precision measure of x_0 is given by the relation

$$P_0^2 = \frac{R_0^2}{x_0^2} = P_a^2 + P_b^2 + \dots + P_p^2 + P_\alpha^2 + P_\beta^2 + \dots + P_\rho^2. \quad (124)$$

When the numerical computation of the P 's is simpler than that of the D 's, P_0 is first computed by equation (124) and then R_0 is determined by the relation

$$R_0 = x_0 P_0. \quad (125)$$

The expression of the final result of the observations and computations in the form

$$X_0 = x_0 \pm R_0$$

has exactly the same significance with respect to X_0 , x_0 , and R_0 that (118) has with respect to X , x , and R_x . It should not be used until all of the underlying conditions have been fulfilled as pointed out in the preceding article. Confusion of the precision measure R_0 with the probable error E_0 , and insufficient rigor in eliminating constant errors have led many experimenters to an entirely fictitious idea of the precision of their measurements.

When the correction factors are explicitly expressed in the reduction formulæ, as in equations (112) and (120), the only difference between the expressions for direct and derived measurements is seen to lie in the greater number of directly observed quantities, o_a , o_b , etc., that appear in the latter equation. The same methods of computation are available in both cases and the following remarks apply equally well to either of them.

For practical purposes, the precision measure R is computed to only two significant figures and the corresponding x is carried out to the place occupied by the second significant figure in R . The reasons underlying this rule have been fully discussed in article forty-three, in connection with the probable error, and need not be repeated here. In computing the numerical value of the differential coefficients in equations (113), (114), (121), and (122), the observed components, o_m , o_a , o_b , etc., and the correction factors, α , β , etc., are rounded to three significant figures, and those that affect the result by less than one per cent are neglected. This degree of approximation will always give R within

one unit in the second significant figure and usually decreases the labor of computation.

Generally the components $o_m, o_a, o_b, \text{etc.}$, represent the arithmetical means of series of direct observations that have been corrected for systematic errors. In such cases the corresponding probable errors $E_m, E_a, E_b, \text{etc.}$, can be computed, by equations in the form of (110), from the residuals determined by equations in the form of (103), with the aid of the observations on which the o 's depend. If the observations are sufficiently numerous, the computation of the E 's may be simplified by using formulæ depending on the average error in the form

$$E = 0.845 \frac{[\bar{r}]}{n \sqrt{n-1}}, \quad (34)$$

where $[\bar{r}]$ is the sum of the residuals without regard to sign and n is the number of observations. If the observations on which any of the o 's depend are not of equal weight, the general mean should be used in place of the arithmetical mean and the corresponding probable errors should be computed by equations (41), (42), or (44), depending on the circumstances of the observations.

The o 's in equation (120) are supposed to represent simultaneous values of the directly observed magnitudes. When any of these quantities are continuous functions of the time, or of any other independent variables, it frequently happens that only a single observation can be made on them that is simultaneous with the other components. In such cases this single observation must be used in place of the corresponding o in (120), and its probable error must be determined for use in equation (122). For the latter purpose, it is sometimes possible to make an auxiliary series of observations under the same conditions that prevailed during the simultaneous measurements except that the independent variables are controlled. The required E may be assumed to be equal to the probable error of a single observation in the auxiliary series. Consequently it may be computed by formulæ in the form,

$$E = 0.674 \sqrt{\frac{[rr]}{n-1}},$$

or

$$E = 0.845 \frac{[\bar{r}]}{\sqrt{n(n-1)}},$$

where n is the number of auxiliary observations, and the r 's are the corresponding residuals. In some cases this simple expedient is not available; and approximate values must be assigned to the E 's on theoretical grounds, depending on the nature of the measurements; or more or less extensive experimental investigations must be undertaken to determine their values more precisely.

Such investigations are so various in character and their utility depends so much on the skill and ingenuity of the experimenter, that a detailed general discussion of them would be impossible. They may be illustrated by the following very common case. Suppose that one of the components in equation (120) represents the gradually changing temperature of a bath. In computing x_0 we must use the thermometer reading o_i taken at the time the other components are observed. The errors of the fixed points of the thermometer and its calibration errors enter the equation among the correction factors α , β , etc., and do not concern us in the present discussion. In order to determine the probable error of o_i , the temperature of the bath may be caused to rise uniformly, through a range that includes o_i , by passing a constant current through an electric heating coil, or the bath may be allowed to cool off gradually by radiation. In either case the rate of change of temperature should be nearly the same as prevailed when o_i was observed. A series of corresponding observations of the time T and the temperature t are made under these conditions, and the empirical relation between T and t is determined graphically or by the method of least squares. The probable error of o_i may be assumed to be equal to the probable error of a single observation of t in this series, and may be computed by equation (94), article sixty-four.

Some of the correction factors α , β , etc., appearing as components in equations (112) and (120), represent subsidiary observations, and some of them represent physical constants. The subsidiary observations may be treated by the methods outlined above. When the highest attainable precision is desired, the physical constants, together with their probable errors, must be determined by special investigation. In less exact work they may be taken from tables of physical constants. Such tabular values seldom correspond exactly to the conditions of the experiments in hand and their probable errors are seldom given. Generally a considerable range of values is given, and, unless

there is definite reason in the experimental conditions for the selection of a particular value, the mean of all of them should be adopted and its probable error placed equal to one-half the range of the tabular values. The deviations of the tabular values from the mean are due more to differences in experimental conditions and in the material treated than to accidental errors. Consequently a probable error calculated from the deviations would have no significance unless these differences could be taken into account. The selection of suitable values from tables of physical constants requires judgment and experience, and the general statements above should not be blindly followed. In many cases the original sources of the data must be consulted in order to determine the values that most nearly satisfy the conditions of the experiments in hand.

In good practice the conditions of the experiment are usually so arranged that the D 's, in equation (123), corresponding to the direct observations o_a , o_b , etc., are all equal. None of the D 's corresponding to correction factors should be greater than this limit, but it sometimes happens that some of them are much smaller. Since R_0 is to be computed to only two significant figures, any single D which is less than one-tenth of the average of the other D 's may be neglected in the computation. If the sum of any number of D 's is less than one-tenth of the average of the remaining D 's they may all be neglected. A somewhat more rigorous limit of rejection can be developed for use in planning proposed measurements, but it is scarcely worth while in the present connection since the correction factors and all other quantities must be taken as they occurred in the actual measurements, and negligible D 's are very easily distinguished by inspection after a little experience.

After R_0 has been determined, x_0 may be computed by either equation (119) or (120). If (119) is used the x 's must first be determined by (102) or (112). Sometimes the computation may be facilitated by using a modification of (120), in which some of the correction factors appear explicitly while others are allowed to remain implicit in the x 's to which they apply. Such cases cannot be treated generally, but must be left to the ingenuity of the computer. Whatever formula is used, the observed quantities and the correction factors should be expressed by sufficient significant figures to give the computed x_0 within a few units in

the place occupied by the second significant figure of R_0 . Occasionally the total effect of one or more of the correction factors is less than this limit and may be neglected in the computation. For a single factor, say α , this is the case when $\frac{\partial F}{\partial \alpha} \alpha$ is less than $\frac{R_0}{10}$.

73. Numerical Example. — The following illustration represents a series of measurements taken for the purpose of calibrating the interval between the twenty-fifth and seventy-fifth graduations on a steel scale supposed to be divided in centimeters. The observations were made with a cathetometer provided with a brass scale and a vernier reading to one one-thousandth of a division. One division of the level on this instrument corresponds to an angular deviation of 3×10^{-4} radians, and the adjustments were all well within this limit. The steel scale was placed in a vertical position with the aid of a plumb-line, and, since a deviation of one-half millimeter per meter could have been easily detected, the error of this adjustment did not exceed 5×10^{-4} radians. Consequently the angle between the two scales was not greater than 8×10^{-4} radians, and it may have been much smaller than this. The temperature of the scales was determined by mercury in glass thermometers hanging in loose contact with them. The probable error of these determinations was estimated at five-tenths of a degree centigrade, due partly to looseness of contact and partly to an imperfect knowledge of the calibration errors of the thermometers.

Twenty independent observations, when tested by the last two criteria of article sixty-eight, showed no evidence of the presence of systematic errors or mistakes. Consequently the mean o_m , in terms of cathetometer scale divisions, and its probable error E_m were computed before the removal of constant errors. The following numerical data represents the results of the observations and the known calibration constants of the cathetometer.

Mean temperature of the steel scale, T	$20^\circ \pm 0^\circ.5$ C.
Mean temperature of the brass scale, t_1	$21^\circ.3 \pm 0^\circ.5$ C.
Mean of twenty observations on the measured interval in terms of brass scale divisions, o_m . .	50.0051 ± 0.0015 scale div.
Mean length, at standard temperature, of the brass scale divisions in the interval used, S . .	0.999853 ± 0.000024 cm.
Standard temperature of brass scale, t_0	$15^\circ.0$ C.
Coefficient of linear expansion of brass scale, α .	$(182 \pm 12) \times 10^{-7}$.
Angle between two scales, β , less than	8×10^{-4} rad.

The most probable value that can be assigned to the measured interval is given by the expression

$$x = o_m S \{1 + \alpha (t_1 - t_0)\} \frac{1}{\cos \beta}.$$

Since β is a very small angle, $\frac{1}{\cos \beta}$ may be treated by the approximate formulæ of Table VII, and the above expression becomes

$$x = o_m S (1 + \alpha t) \left(1 + \frac{\beta^2}{2}\right),$$

where

$$t = t_1 - t_0.$$

The quantity $S (1 + \alpha t)$ is very nearly equal to unity. Hence, neglecting small quantities of the second and higher orders, the correction due to the angle β is

$$\begin{aligned} o_m \frac{\beta^2}{2} &< 50 \times \frac{64}{2} \times 10^{-8}, \\ &< 0.000016. \end{aligned}$$

Since this is less than two per cent of the probable error of o_m , it is negligible in comparison with the accidental errors of observation. Consequently the precision of x is not increased by retaining the term involving β , and we may put

$$x = o_m S (1 + \alpha t). \quad (a)$$

The probable error of t_0 is zero, because the accidental errors of the temperature observations, made during the calibration of the brass scale, are included in the probable errors of S and α computed by the method of article sixty-five. Consequently the probable error of t is equal to that of t_1 , and we have

$$t = 6^\circ.3 \pm 0^\circ.5 \text{ C.}$$

In the present case equation (115) is the most convenient for computing the precision measure R_x of x . Only two significant figures are to be retained in the separate effects computed by equation (114). Consequently the factor $(1 + \alpha t)$ may be taken equal to unity, and the numerical values of o_m and S may be rounded to three significant figures for the purpose of this computation. Thus, taking o_m equal to 50.0, S equal to 1.00, and the other data as given above, we have

$$\begin{aligned}
 D_m &= \frac{\partial x}{\partial o_m} E_m = S (1 + \alpha t) E_m = & 1 \times E_m = 0.0015. \\
 D_s &= \frac{\partial x}{\partial S} E_s = o_m (1 + \alpha t) E_s = & 50 \times E_s = 0.0012. \\
 D_\alpha &= \frac{\partial x}{\partial \alpha} E_\alpha = o_m S t E_\alpha = & 50 \times 6.3 \times E_\alpha = 0.00038. \\
 D_t &= \frac{\partial x}{\partial t} E_t = o_m S \alpha E_t = & 50 \times 182 \times 10^{-7} \times E_t = 0.00046. \\
 & & D_m^2 = 225.0 \times 10^{-8} \\
 & & D_s^2 = 144.0 \times 10^{-8} \\
 & & D_\alpha^2 = 14.4 \times 10^{-8} \\
 & & D_t^2 = 21.2 \times 10^{-8} \\
 & & \underline{[D^2] = 404.6 \times 10^{-8}}
 \end{aligned}$$

Hence, by equation (115),

$$\begin{aligned}
 R_x^2 &= [D^2] = 404.6 \times 10^{-8}, \\
 R_x &= \sqrt{404.6 \times 10^{-8}} = 0.0020.
 \end{aligned}$$

For the purpose of computing x , it is convenient to put the given data in the form

$$\begin{aligned}
 o_m &= 50 (1 + 0.000102), \\
 S &= 1 - 0.000147, \\
 \alpha t &= 0.000115.
 \end{aligned}$$

Then, by equation (a),

$$x = 50 (1 + 0.000102) (1 - 0.000147) (1 + 0.000115),$$

and by formula 7, Table VII,

$$\begin{aligned}
 x &= 50 (1 + 0.000102 - 0.000147 + 0.000115) \\
 &= 50 (1 + 0.00007) \\
 &= 50.0035.
 \end{aligned}$$

This method of computation, by the use of the approximate formulæ of Table VII, gives x within less than one unit in the last place held, and is much less laborious than the use of logarithms.

Since the length S of the cathetometer scale divisions is given in centimeters, the computed values of x and R_x are also expressed in centimeters and our uncertainty regarding the true distance L between the twenty-fifth and the seventy-fifth graduations of the steel scale is definitely stated by the expression

$$L = 50.0035 \pm 0.0020 \text{ centimeters,}$$

at the temperature

$$T = 20^\circ.0 \pm 0^\circ.5 \text{ C.}$$

The above discussion shows that the precision of the result would not have been materially increased by a more accurate determination of T , t_1 , and α , since the effects of the errors of these quantities are small in comparison with that of the errors of o_m and S . The probable error of o_m might have been reduced by making a larger number of observations and taking care to keep the instrument in adjustment within one-tenth of a level division or less. But the given value of E_m is of the same order of magnitude as the least count of the vernier used, and, since each observation represents the difference of two scale readings, it would not be decreased in proportion to the increased labor of observation. Moreover, the terms D_m and D_s in the above value of R_x are nearly equal in magnitude, and it would not be worth while to devote time and labor to the reduction of one of them unless the other could be reduced in like proportion.

CHAPTER XI.

DISCUSSION OF PROPOSED MEASUREMENTS.

74. Preliminary Considerations. — The measurement of a given quantity may generally be carried out by any one of several different, and more or less independent, methods. The available instruments usually differ in type and in functional efficiency. A choice among methods and instruments should be determined by the desired precision of the result and the time and labor that it is worth while to devote to the observations and reductions.

Since the labor of observation and the cost of instruments increase more rapidly than the inverse square of the precision measure of the attained result, a considerable waste of time and money is involved in any measurement that is executed with greater precision than is demanded by the use to which the result is to be put. On the other hand, if the precision attained is not sufficient for the purpose in hand, the measurement must be repeated by a more exact method. Consequently the labor and expense of the first determination contributes very little to the final result and the waste is quite as great as in the preceding case. Sometimes the expense of a second determination is avoided by using the inexact result of the first, but such a saving is likely to prove disastrous unless the uncertainty of the adapted data is duly considered.

In general the greatest economy is attained by so planning and executing the measurement that the result is given with the desired precision and neglecting all refinements of method and apparatus that are not essential to this end. While these considerations have greater weight in connection with measurements carried out for practical purposes they should never be neglected in planning investigations undertaken primarily for the advancement of science. In the former case the cost of necessary measurements may represent an appreciable fraction of the expense of a proposed engineering enterprise and must be taken into account in preparing estimates. In the latter case there is no excuse for burdening the limited funds available for research with the expense

of ill-contrived and haphazard measurements. The precision requirements may be, and indeed usually are, quite different in the two cases, but the same process of arriving at suitable methods applies to both.

75. The General Problem. — In its most general form the problem may be stated as follows: Required the magnitude of a quantity X within the limits $\pm R$, X being a function of several directly measured quantities X_1, X_2 , etc.; within what limits must we determine the value of each of the components X_1, X_2 , etc.? In discussing this problem, all sources of error both constant and accidental must be taken into account. For this purpose the various methods available for the measurement of the several components are considered with regard to the labor of execution and the magnitude of the errors involved as well as with regard to the facility and accuracy with which constant errors can be removed.

After such a study, certain definite methods are adopted provisionally, and examined to determine whether or not the required precision in the final result can be attained by their use. As the first step in this process, the function that gives the relation between X and the components, X_1, X_2 , etc., is written out in its most complete form with all correction factors explicitly represented. Thus, as in article seventy-two, the most probable value of the quantity X may be expressed in the form

$$x_0 = \theta(o_a, o_b, \dots, o_p, \alpha, \beta, \dots, \rho), \quad (120)$$

where the o 's represent observed values of X_1, X_2 , etc., and $\alpha, \beta, \dots, \rho$, represent the factors on which the corrections for constant errors depend as pointed out in connection with equation (112), article seventy-one.

The form of the function θ , and the nature and magnitude of the correction factors appearing in it, will depend on the nature of the proposed methods of measurement. Since all detectable constant errors are explicitly represented by suitable correction factors, all of the quantities appearing in the function θ may be treated as directly measured components subject to accidental errors only. Hence the problem reduces to the determination of the probable errors within which each of the components must be determined in order that the computed value of x_0 may come out with a precision measure equal to the given magnitude R_0 . If all of the components can be determined within the limits set

by the probable errors thus found, without exceeding the limits of time and expense imposed by the preliminary considerations, the provisionally adopted methods are adequate for the purpose in hand and the measurements may be carried out with confidence that the final result will be precise within the required limits. When one or more of the components cannot be determined within the limits thus set without undue labor or expense, the proposed methods must be modified in such a manner that the necessary measurements will be feasible.

76. The Primary Condition. — The present problem is, to some extent, the inverse of that treated in articles seventy-one and seventy-two. In the latter case the given data represented the results of completed series of observations on the several component quantities appearing in the function θ , together with their respective probable errors. The purpose of the analysis was the determination of the most probable value x_0 that could be assigned to the measured magnitude and the precision measure of the result. In the present case approximate values of x_0 and the components in θ are given, and the object of the analysis is the determination of the probable errors within which each of the components must be measured in order that the value of x_0 , computed from the completed observations, may come out with a precision measure equal to a given magnitude R_0 .

If $D_a, D_b, \dots, D_p, D_\alpha, D_\beta, \dots, D_\rho$ represent the separate effects of the probable errors $E_a, E_b, \dots, E_p, E_\alpha, E_\beta, \dots, E_\rho$ of the components $o_a, o_b, \dots, o_p, \alpha, \beta, \dots, \rho$, respectively, we have, as in article seventy-two,

$$D_a = \frac{\partial \theta}{\partial o_a} E_a; \dots; D_p = \frac{\partial \theta}{\partial o_p} E_p; D_\alpha = \frac{\partial \theta}{\partial \alpha} E_\alpha; \dots; D_\rho = \frac{\partial \theta}{\partial \rho} E_\rho, \quad (122)$$

and the *primary condition* imposed on these quantities is given by the relation

$$R_0^2 = D_a^2 + D_b^2 + \dots + D_p^2 + D_\alpha^2 + D_\beta^2 + \dots + D_\rho^2. \quad (123)$$

The precision measure R_0 and approximate values of the components are given by the conditions of the problem and the proposed methods of measurement. The E 's, and hence also the D 's, are the unknown quantities to be determined. Consequently there are as many unknowns in equation (123) as there are different components in the function θ . Obviously the problem is indeterminate unless some further conditions can be imposed

on the D 's; for otherwise it would be possible to assign an infinite number of different values to each of the D 's which, by proper selection and combination, could be made to satisfy the primary condition (123).

77. The Principle of Equal Effects. — An ideal condition to impose on the D 's would specify that they should be so determined that the required precision in the final result x_0 would be attained with the least possible expense for labor and apparatus. Unfortunately this condition cannot be put into exact mathematical form since there is no exact general relation between the difficulty and the precision of measurements. However, it is easy to see that the condition is approximately fulfilled when the measurements are so made that the D 's are all equal to the same magnitude. For, the probable error of any component is inversely proportional to the square root of the number of observations on which it depends and the expense of a measurement increases directly with the number of observations. Consequently the expense W_a of the component o_a is approximately proportional to $\frac{1}{E_a^2}$ or, since $\frac{\partial \theta}{\partial o_a}$ is constant, to $\frac{1}{D_a^2}$. Similar relations hold for the other components. Hence, as a first approximation, we may assume that

$$W = \frac{A^2}{D_a^2} + \frac{A^2}{D_b^2} + \cdots + \frac{A^2}{D_\alpha^2} + \frac{A^2}{D_\beta^2} + \cdots, \quad (126)$$

where W is the total expense of the determination of x_0 , and A is a constant. By the usual method of finding the minimum value of a function of conditioned quantities, the least value of W consistent with equation (123) occurs when the D 's satisfy (123) and also fulfill the relations

$$\frac{\partial W}{\partial D_a} + K^2 \frac{\partial R_0^2}{\partial D_a} = 0,$$

$$\frac{\partial W}{\partial D_b} + K^2 \frac{\partial R_0^2}{\partial D_b} = 0,$$

$$\cdot \quad \cdot \quad \cdot \quad \cdot \quad \cdot$$

$$\frac{\partial W}{\partial D_\alpha} + K^2 \frac{\partial R_0^2}{\partial D_\alpha} = 0,$$

$$\frac{\partial W}{\partial D_\beta} + K^2 \frac{\partial R_0^2}{\partial D_\beta} = 0,$$

$$\cdot \quad \cdot \quad \cdot \quad \cdot \quad \cdot$$

where K is a constant. Introducing the expressions for R_0^2 and W in terms of the D 's, differentiating, and reducing, we have

$$D_a^2 = D_b^2 = \dots = D_\alpha^2 = D_\beta^2 = \dots = \frac{A}{K},$$

and by equation (123)

$$\frac{A}{K} = \frac{R_0^2}{N},$$

where N is the number of D 's in (123) or the equal number of components in the function θ . Consequently equation (123) is fulfilled and the condition of minimum expense is approximately satisfied when the components are so determined that the separate effects of their probable errors satisfy the relation

$$D_a = D_b = \dots = D_\alpha = D_\beta = \dots = \frac{R_0}{\sqrt{N}}. \quad (127)$$

Equation (127) is the mathematical expression of the *principle of equal effects*. It does not always express an exact solution of the problem, since A is seldom strictly constant; but it is the best approximation that we can adopt for the preliminary computation of the D 's and E 's. The results thus obtained will usually require some adjustment among themselves before they will satisfy both the preliminary considerations and the primary condition (123). We shall see that the necessary adjustment is never very great; and, in fact, that a marked departure from the condition of equal effects is never possible when equation (123) is satisfied.

Combining equations (122) and (127), we find

$$\left. \begin{aligned} E_a &= \frac{R_0}{\sqrt{N}} \cdot \frac{1}{\frac{\partial \theta}{\partial a}}; & E_\alpha &= \frac{R_0}{\sqrt{N}} \cdot \frac{1}{\frac{\partial \theta}{\partial \alpha}}; \\ E_b &= \frac{R_0}{\sqrt{N}} \cdot \frac{1}{\frac{\partial \theta}{\partial b}}; & E_\beta &= \frac{R_0}{\sqrt{N}} \cdot \frac{1}{\frac{\partial \theta}{\partial \beta}}; \\ & \dots & & \dots \end{aligned} \right\} \quad (128)$$

Hence, if the final measurements are so executed that the probable errors of the several components are equal to the corresponding values given by equations (128), the final result x_0 , computed by equation (120), will come out with a precision measure equal to

the specified R_0 , and the condition of equal effects (127) will be fulfilled.

In computing the E 's by equation (128), R_0 is taken equal to the given precision measure of x_0 and N is placed equal to the number of components in the function θ . The derivatives $\frac{\partial \theta}{\partial o_a}$ etc., are evaluated with the aid of approximate values of the components obtained by a preliminary trial of the proposed methods or by computation, on theoretical grounds, from an approximate value of x_0 and a knowledge of the conditions under which the measurements are to be made. Since only two significant figures are required in any of the E 's, the adopted values of the components may be in error by several per cent, without affecting the significance of the results. Moreover, any number of components, whose combined effect on any derivative is less than five per cent, may be entirely neglected in computing that derivative. Consequently the function θ frequently may be simplified very much for the purpose of computing the derivatives and this simplification may take different forms in the case of different derivatives. No more than three significant figures should be retained at any step of the process and sometimes the required precision can be attained with the approximate formulæ of Table VII.

Since equation (127) is an approximation, the E 's derived from equations (128) are to be regarded as provisional limits for the corresponding components. If all of them are attainable, i.e., if all of the components can be determined within the provisional limits, without exceeding the limit of expense set by the preliminary considerations, the solution of the problem is complete and the proposed methods are suitable for the work in hand.

78. Adjusted Effects. — Generally some of the E 's given by (128) will be unattainable in practice while others will be larger than a limit that can be easily reached. In other words, it will be found that the labor involved in determining some of the components within the provisional limit is prohibitive while other components can be determined with more than the provisional precision without undue labor. In such a case the provisional limits are modified by increasing the E 's corresponding to the more difficult determinations and decreasing the E 's that correspond to the more easily determinable components in such a way that the combined effects satisfy the condition (123).

The maximum allowable increase in a single E is by the factor \sqrt{N} . For, taking E_a for illustration,

$$\sqrt{N}E_a = R_0 \frac{1}{\frac{\partial \theta}{\partial o_a}} = E_a',$$

and consequently

$$D_a' = \frac{\partial \theta}{\partial o_a} E_a' = R_0.$$

Hence (123) cannot be satisfied unless all of the rest of the D 's are negligibly small. For example, if there are nine components, \sqrt{N} is equal to three. Consequently no one of the E 's can be increased to more than three times the value given by the condition of equal effects if (123) is to be satisfied. When, as is frequently the case, the number of components is less than nine, or when more than one of the E 's is to be increased, the limit of allowable adjustment is much less than the above. The extent to which any number of E 's may be increased is also limited by the difficulty, or impossibility, of reducing the effects of the remaining E 's to the negligible limit.

If the probable errors given by equations (128) can be modified, to such an extent that the corresponding measurements become feasible, without violating the condition (123), the proposed methods are suitable for the final determination of x_0 . Otherwise they must be so modified that they satisfy the conditions of the problem or different methods may be adopted provisionally and tested for availability as above.

Sometimes it will be found that the proposed methods are capable of greater precision than is demanded by equations (128). In such cases the expense of the measurements may be reduced without exceeding the given precision measure of x_0 by using less precise methods. But such methods should never be finally adopted until their feasibility has been tested by the process outlined above.

A discussion on the foregoing lines not only determines the practicability of the proposed methods, but also serves as a guide in determining the relative care with which the various parts of the work should be carried out. For, if the final result is to come out with a precision measure R_0 , it is obvious that all adjustments and measurements must be so executed that each of the com-

ponents is determined within the limits set by equations (128), or by the adjusted E 's that satisfy (123).

79. Negligible Effects.—In the preceding article it was pointed out that the availableness of proposed methods of measurement frequently depends on the possibility of so adjusting the E 's given by equations (128) that they are all attainable and at the same time satisfy the primary condition (123). Generally this cannot be accomplished unless some of the E 's can be reduced in magnitude to such an extent that their effect on the precision measure R_0 is negligible.

On account of the meaning of the precision measure, and the fact that it is expressed by only two significant figures, it is obvious that any D is negligible when its contribution to the value of R_0 is less than $\frac{R_0}{10}$. Thus, if R_1 is the value of the right-hand member of equation (123), when D_a is omitted, D_a is negligible provided

$$R_0 - R_1 < \frac{R_0}{10},$$

or

$$0.9 R_0 < R_1.$$

Squaring gives

$$0.81 R_0^2 < R_1^2,$$

and by definition

$$R_0^2 - R_1^2 = D_a^2.$$

Consequently

$$0.81 R_0^2 < R_0^2 - D_a^2,$$

and

$$D_a^2 < 0.19 R_0^2,$$

or

$$D_a < 0.436 R_0.$$

Hence, if D_a is less than $0.436 R_0$, it will contribute less than ten per cent of the value of R_0 . Since the true error of x_0 is as likely to be greater than R_0 as it is to be less than R_0 , a change of ten per cent in the value of R_0 can have no practical importance. Consequently D_a is negligible when it satisfies the above condition. However, the constant 0.436 is somewhat awkward to handle, and if D_a is very nearly equal to the limit $0.436 R_0$, the propriety of omitting it is doubtful. These difficulties may be avoided by adopting the smaller and more easily calculated limit of rejection given by the condition

$$D \equiv \frac{1}{3} R_0. \quad (129)$$

This limit corresponds to a change of about six per cent in the value of R_0 given by equation (123), and is obviously safe for all practical purposes. Since the above reasoning is independent of the particular D chosen, the condition (129) is perfectly general and applies to any one of the D 's in equation (123).

When two or more of the D 's satisfy (129) independently, any one of them may be neglected, but all of them cannot be neglected without further investigation for otherwise the change in R_0 might exceed ten per cent. This would always happen if all of the D 's considered were very nearly equal to the limit $\frac{R_0}{3}$.

However, by analogy with the above argument, it is obvious that any q of the D 's are simultaneously negligible when

$$\sqrt{D_1^2 + D_2^2 + \dots + D_q^2} \cong \frac{1}{3} R_0, \quad (130)$$

where the numerical subscripts 1, 2, . . . , q are used in place of the literal subscripts occurring in equation (123) in order to render the condition (130) entirely general. Thus D_1 may correspond to any one of the D 's in (123), D_2 to any other one, etc. By applying the principle of equal effects, the condition (130) may be reduced to the simple form

$$D_1 = D_2 = \dots = D_q \cong \frac{1}{3} \frac{R_0}{\sqrt{q}}. \quad (131)$$

If some of the D 's in (131) can be easily reduced below the limit $\frac{R_0}{3\sqrt{q}}$, the others may exceed that limit somewhat without violating the condition (130). However, equation (131) generally gives the best practical limit for the simultaneous rejection of a number of D 's, and all departures from it should be carefully checked by (130).

To illustrate the practical application of the foregoing discussion, suppose that the practicability of certain proposed methods of measurement is to be tested by the principle of equal effects developed in article seventy-seven. Let there be N components in the function θ , and suppose that q of them, represented by $\alpha_1, \alpha_2, \dots, \alpha_q$, can be easily determined with greater precision than is demanded by equations (128), while the measurement of the remaining $N - q$ components within the limits thus set would be very difficult. Obviously some adjustment of the E 's given by (128) is desirable in order that the labor involved in the various parts of the measurement may be more evenly balanced.

The greatest possible increase in the E 's corresponding to the $N - q$ difficult components will be allowable when the E 's of the q easy components can be reduced to the negligible limit. To determine the necessary limits, R_0 is taken equal to the given precision measure of x_0 , and the negligible D 's corresponding to the q easy components are determined by equation (131). Then by equations (122), the corresponding E 's will be negligible when

$$\left. \begin{aligned} E_1 &\cong \frac{1}{3} \frac{R_0}{\sqrt{q}} \cdot \frac{1}{\frac{\partial \theta}{\partial \alpha_1}}, \\ E_2 &\cong \frac{1}{3} \frac{R_0}{\sqrt{q}} \cdot \frac{1}{\frac{\partial \theta}{\partial \alpha_2}}, \\ &\dots \dots \dots \\ E_q &\cong \frac{1}{3} \frac{R_0}{\sqrt{q}} \cdot \frac{1}{\frac{\partial \theta}{\partial \alpha_q}} \end{aligned} \right\} \quad (132)$$

If these limits can be attained with as little difficulty as the previously determined E 's of the $N - q$ remaining components, the corresponding D 's may be omitted from equation (123) during the further discussion of precision limits.

Since q of the D 's have disappeared, the others may be somewhat increased and still satisfy the primary condition (123). The corresponding new limits for the E 's of the difficult components may be obtained from equations (127) and (128) by replacing N by $N - q$. If these new limits together with the negligible limits given by equations (132) can all be attained, without exceeding the expense set by the preliminary considerations, the proposed methods may be considered suitable for the final determination of x_0 with the desired precision. Otherwise new methods must be devised and investigated as above.

Equations (132) may also be used to determine the extent to which mathematical constants should be carried out during the computations. For this purpose the components $\alpha_1, \alpha_2, \dots, \alpha_q$, or part of them, represent the mathematical constants appearing in the function θ . The corresponding E 's, determined by equations (132), give the allowable limits of rejection in rounding the numerical values of the constants for the purpose of simplifying

the computations. Thus, suppose that the volume of a right circular cylinder of length L and radius a is to be computed within one-tenth of one per cent, how many figures should be retained in the constant π ? In this case

$$\begin{aligned}\theta(\alpha, \dots, \alpha, \dots) &= V = \pi a^2 L, \\ R_0 &= 0.001 V = 0.001 \pi a^2 L, \\ \frac{\partial \theta}{\partial \alpha} &= \frac{\partial V}{\partial \pi} = a^2 L; \quad q = 1, \\ \therefore E_\pi &= \frac{R_0}{3} \cdot \frac{1}{a^2 L} = \frac{0.001 \pi}{3} = 0.00105.\end{aligned}$$

If π is taken equal to 3.142 the error due to rounding is 0.00041 —. Since this is less than the negligible limit E_π , four significant figures in π are sufficient for the purpose in hand.

It sometimes happens that the total effect of one or more of the components in the function θ , on the computed value of x_0 , is negligible in comparison with R_0 . This will obviously be the case when

$$\frac{\partial \theta}{\partial \alpha} \alpha \equiv \frac{R_0}{3},$$

for a single component α or when

$$\left\{ \left(\frac{\partial \theta}{\partial \alpha_1} \alpha_1 \right)^2 + \left(\frac{\partial \theta}{\partial \alpha_2} \alpha_2 \right)^2 + \dots + \left(\frac{\partial \theta}{\partial \alpha_q} \alpha_q \right)^2 \right\}^{\frac{1}{2}} \equiv \frac{R_0}{3}$$

for q components. Thus, on the principle of equal effects, the components $\alpha_1, \alpha_2, \dots, \alpha_q$ will be simultaneously negligible when they satisfy the conditions

$$\left. \begin{aligned}\alpha_1 &\equiv \frac{1}{3} \cdot \frac{R_0}{\sqrt{q}} \cdot \frac{1}{\frac{\partial \theta}{\partial \alpha_1}}, \\ \alpha_2 &\equiv \frac{1}{3} \cdot \frac{R_0}{\sqrt{q}} \cdot \frac{1}{\frac{\partial \theta}{\partial \alpha_2}}, \\ &\dots \dots \dots \\ \alpha_q &\equiv \frac{1}{3} \cdot \frac{R_0}{\sqrt{q}} \cdot \frac{1}{\frac{\partial \theta}{\partial \alpha_q}}.\end{aligned} \right\} \quad (133)$$

Such cases frequently arise in connection with the components that represent correction factors.

80. Treatment of Special Functions. — During the foregoing argument, it has been assumed that the function θ in equation (120) is expressed in the most general form consistent with the proposed methods of measurement. Such an expression involves the explicit representation of all directly measured quantities, and all possible correction factors. Part of the latter class of components represent departures of the proposed methods from the theoretical conditions underlying them, and others depend upon inaccuracies in the adjustment of instruments. In practice it frequently happens that the general function θ is very complicated, and consequently that the direct discussion of precision as above is a very tedious process. Under these conditions it is desirable to modify the form of the function in such a manner as to facilitate the discussion.

Sometimes the general function θ can be broken up into a series of independent functions or expressed as a continuous product of such functions. Thus, it may be possible to express θ in the form

$$\left. \begin{aligned} x_{\theta} &= \theta (o_a, o_b, \dots, \alpha, \beta, \dots) \\ &= f_1 (a_1, a_2, \dots) \pm f_2 (b_1, b_2, \dots) \pm f_3 (c_1, c_2, \dots) \\ &\quad \pm \dots \pm f_n (m_1, m_2, \dots), \end{aligned} \right\} (134)$$

or in the form

$$\left. \begin{aligned} x_{\theta} &= \theta (o_a, o_b, \dots, \alpha, \beta, \dots) \\ &= f_1 (a_1, a_2, \dots) \times f_2 (b_1, b_2, \dots) \times f_3 (c_1, c_2, \dots) \\ &\quad \times \dots \times f_n (m_1, m_2, \dots), \end{aligned} \right\} (135)$$

where the a 's, b 's, \dots , and m 's represent the same components, $o_a, o_b, \dots, \alpha, \beta, \dots$, that appear in θ by a new and more general notation. The functions f_1, f_2, \dots, f_n may take any form consistent with the problem in hand, but the precision discussion will not be much facilitated unless they are independent in the sense that no two of them contain the same or mutually dependent variables. Sometimes the latter condition is impracticable and it becomes necessary to include the same component in two or more of the functions. Under such conditions the expansion has no advantage over the general expression for θ , unless the effect of the errors of each of the common components can be rendered negligible in all but one of the functions. It is scarcely necessary to point out that equations (134) and (135) represent different problems, and that if it were possible to expand

the same function θ in both ways, the component functions f_1, f_2, \dots, f_n would be different in the two cases.

For the sake of convenience let

$$\left. \begin{aligned} f_1(a_1, a_2, \dots) &= z_1, \\ f_2(b_1, b_2, \dots) &= z_2, \\ \cdot & \cdot \\ f_n(m_1, m_2, \dots) &= z_n. \end{aligned} \right\} \quad (136)$$

Then equation (134) may be written in the form

$$x_0 = z_1 \pm z_2 \pm z_3 \pm \dots \pm z_n, \quad (137)$$

and (135) may be put in the form

$$x_0 = z_1 \times z_2 \times z_3 \times \dots \times z_n. \quad (138)$$

First consider the case in which the function representing the proposed methods of measurement has been put in the form of (137). Since the precision measure follows the same laws of propagation as the probable error, the discussion given in article fifty-eight leads to the relation

$$R_0^2 = R_1^2 + R_2^2 + R_3^2 + \dots + R_n^2, \quad (139)$$

where R_0 is the precision measure of x_0 , and each of the other R 's represents the precision measure of the z with corresponding subscript. Hence, by the principle of equal effects, provisional values of the R 's may be obtained from the relation

$$R_1 = R_2 = R_3 = \dots = R_n = \frac{R_0}{\sqrt{n}}. \quad (140)$$

The R 's having been determined by (140), the corresponding probable errors of the a 's, b 's, etc., may be computed by the methods of the preceding articles with the aid of equations (136). If the provisional limits of precision thus found are not all attainable with approximately equal facility, the conditions of the problem may be better satisfied by moderately adjusted relative values of the probable errors as pointed out in article seventy-eight. Obviously the adjusted values must satisfy equation (139) if the value of x_0 computed by (137) is to come out with a precision measure equal to the given R_0 .

When the function representing the proposed methods can be put in the form of (138) the computation is facilitated by introducing the fractional errors

$$P_0 = \frac{R_0}{x_0}; \quad P_1 = \frac{R_1}{z_1}; \quad P_2 = \frac{R_2}{z_2}; \quad \dots; \quad P_n = \frac{R_n}{z_n}. \quad (141)$$

For, by the argument underlying equation (83), article sixty-two,

$$P_0^2 = P_1^2 + P_2^2 + P_3^2 + \dots + P_n^2, \quad (142)$$

and, by the principle of equal effects, provisional values of the P 's are given by the relation

$$P_1 = P_2 = P_3 = \dots = P_n = \frac{P_0}{\sqrt{n}}. \quad (143)$$

Since R_0 and approximate values of the components are given, P_0 can be computed with sufficient accuracy with the aid of (138) and the first of (141). Consequently provisional fractional limits for the components can be determined by (143), and the corresponding precision measures by the last n of equations (141). Beyond this point the problem is identical with the preceding case, except that the adjusted limits of precision must satisfy (142) in place of (139).

The methods developed in the preceding articles are entirely general and applicable to any form of the function θ , but they frequently lead to complicated computations. In the present article we have seen how the discussion can be simplified when the function θ can be put in either of the particular forms represented by (134) and (135). Many of the problems met with in practice cannot be put in either of these special forms, but it frequently happens that the treatment of the functions representing them can be simplified by a suitable modification or combination of the above general and particular methods. The general ideas underlying all discussions of the necessary precision of components have been discussed above with sufficient fullness to show their nature and significance. Their application to particular problems must be left to the ingenuity of the observer and computer.

81. Numerical Example. — As an illustration of the foregoing methods, suppose that the electromotive force of a battery is to be determined, and that the precision measure of the result is required to satisfy the condition

$$R_0 = \pm 0.0012 \text{ volts}, \quad (i)$$

within the limits $\pm \frac{R_0}{10}$, i.e., R_0 must lie between ± 0.0011 and ± 0.0013 volt. Preliminary considerations demand that the expense of the work shall be as low as is consistent with the required precision.

The given conditions are most likely to be fulfilled by some form of potentiometer method. Suppose that the arrangement of apparatus illustrated in Fig. 10 is adopted provisionally; and, to simplify the discussion, suppose that the various parts of the apparatus are so well insulated that leakage currents need not be considered. The generality of the problem is not appreciably affected by the latter assumption since the specified condition can be easily satisfied in practice within negligible limits. With what precision must the several components and correction factors be determined in order that equation (i) may be satisfied?

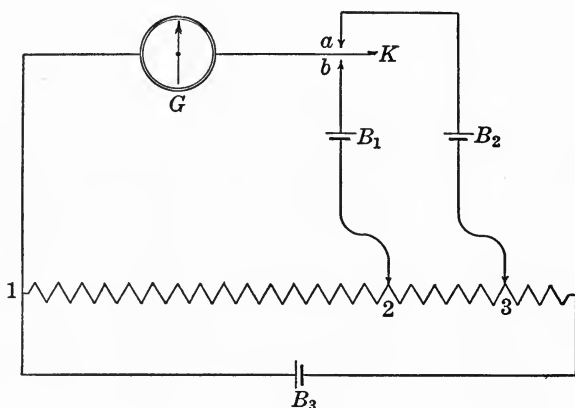

FIG. 10.

- Let V = e.m.f. of tested battery B_1 ,
 E_t = e.m.f. of Clark cell B_2 at time of observation,
 t = temperature of Clark cell at time of observation,
 R_1 = resistance between 1 and 2,
 R_2 = resistance between 1 and 3,
 I = current in circuit 1, 2, 3, B_3 , 1 when the key K is open,
 δ_1 = algebraic sum of thermo e.m.f.'s in the circuit 1, 2, b ,
 G , 1 when K is closed to b ,
 δ_2 = algebraic sum of thermo e.m.f.'s in the circuit 1, 3, a ,
 G , 1 when K is closed to a ,
 E_{15} = e.m.f. of Clark cell at temperature 15°C .,
 α = mean temperature coefficient of Clark cell in the neighborhood of 20°C .

When the sliding contacts 2 and 3 are so adjusted that the galvanometer G shows no deflection on closing the key K to either a or b ,

$$I = \frac{V + \delta_1}{R_1} = \frac{E_t + \delta_2}{R_2}.$$

Consequently

$$V = (E_t + \delta_2) \frac{R_1}{R_2} - \delta_1. \quad (\text{ii})$$

But

$$E_t = E_{15} \{1 - \alpha(t - 15)\}. \quad (\text{iii})$$

Hence

$$V = E_{15} \{1 - \alpha(t - 15)\} \frac{R_1}{R_2} + \delta_2 \frac{R_1}{R_2} - \delta_1. \quad (\text{iv})$$

The resistances R_1 and R_2 are functions of the temperature; but, since they represent simultaneous adjustments with the cells B_1 and B_2 and are composed of the same coils, the ratio $\frac{R_1}{R_2}$ is independent of the temperature. Thus, if R_t' and R_t'' represent the resistances of the used coils at t° C., and β is their temperature coefficient,

$$\frac{R_t'}{R_t''} = \frac{R_1(1 + \beta t)}{R_2(1 + \beta t)} = \frac{R_1}{R_2},$$

whatever the temperature t at which the comparison is made. This advantage is due to the particular method of connection and adjustment adopted, and is by no means common to all forms of the potentiometer method.

Under the conditions specified above, equation (iv) may be adopted as the complete expression for the discussion of precision. It corresponds to equation (120) in the general treatment of the problem. Suppose that the following approximate values of the components, which are sufficiently close for the determination of the capabilities of the method, have been obtained from the normal constants of the Clark cell and a preliminary adjustment of the apparatus or by computation from a known approximate value of V :

$$\left. \begin{aligned} E_{15} &= 1.434 \text{ volts; } \alpha = 0.00086; \\ t &= 20^\circ \text{ C.; } R_1 = 1000 \text{ ohms; } \\ R_2 &= 1310 \text{ ohms; } V = 1.1 \text{ volts.} \end{aligned} \right\} \quad (\text{v})$$

The thermoelectromotive forces δ_1 and δ_2 are to some extent due to inhomogeneity of the wires used in the construction of the instruments and connections. For the most part, however,

they arise from the junctions of dissimilar metals in the circuits considered. Suppose that the resistances R_1 and R_2 are made of manganin, the key K of brass, and that the copper used in the galvanometer coil and the connecting wires is thermoelectrically different. Both δ_1 and δ_2 would represent the resultant action of at least six thermo-elements in series. While these effects cannot be accurately specified in advance, their combined action would not be likely to be greater than twenty-five microvolts per degree difference in temperature between the various parts of the apparatus, and it might be much less than this. Obviously δ_1 and δ_2 are both equal to zero when the temperature of the apparatus is uniform throughout.

By equations (133), article seventy-nine, the correction terms depending on thermoelectric forces will be negligible in comparison with the given precision measure R_0 , when δ_1 and δ_2 satisfy the conditions

$$\delta_1 \cong \frac{1}{3} \cdot \frac{R_0}{\sqrt{q}} \cdot \frac{1}{\frac{\partial V}{\partial \delta_1}} \quad \text{and} \quad \delta_2 \cong \frac{1}{3} \cdot \frac{R_0}{\sqrt{q}} \cdot \frac{1}{\frac{\partial V}{\partial \delta_2}}$$

In the present case

$$R_0 = 0.0012 \text{ volt}; \quad q = 2;$$

$$\frac{\partial V}{\partial \delta_1} = -1; \quad \text{and} \quad \frac{\partial V}{\partial \delta_2} = \frac{R_1}{R_2} = 0.76$$

Consequently the above conditions become

$$\delta_1 \cong \frac{1}{3} \cdot \frac{0.0012}{\sqrt{2}} \cdot \frac{1}{-1} \cong \pm 0.00028 \text{ volt} \cong \pm 280 \text{ microvolts,}$$

$$\delta_2 \cong \frac{1}{3} \cdot \frac{0.0012}{\sqrt{2}} \cdot \frac{1}{0.76} \cong \pm 0.00037 \text{ volt} \cong \pm 370 \text{ microvolts.}$$

From the above discussion of the possible magnitude of the thermoelectromotive forces in the circuits considered, it is obvious that these limits correspond to temperature differences of approximately ten degrees between the various parts of the apparatus. Since the temperature of the apparatus can be easily maintained uniform within five degrees, the last two terms in equation (iv) are negligible within the limits of precision set in the present problem. Hence, for the determination of the required precision of the remaining components, the functional relation (iv) may be taken in the form

$$V = E_{15} \{1 - \alpha(t - 15)\} \frac{R_1}{R_2}. \quad (\text{vi})$$

By equation (123), article seventy-six, the primary condition for determining the necessary precision of the components is

$$R_0^2 = 144 \times 10^{-8} = D_1^2 + D_2^2 + D_3^2 + D_4^2 + D_5^2, \quad (\text{vii})$$

where

$$\left. \begin{aligned} D_1 &= \frac{\partial V}{\partial E_{15}} E_1; & D_2 &= \frac{\partial V}{\partial \alpha} E_2; & D_3 &= \frac{\partial V}{\partial t} E_3; \\ D_4 &= \frac{\partial V}{\partial R_1} E_4; & D_5 &= \frac{\partial V}{\partial R_2} E_5, \end{aligned} \right\} \quad (\text{viii})$$

and E_1, E_2, E_3, E_4, E_5 are the required probable errors of $E_{15}, \alpha, t, R_1,$ and $R_2,$ respectively.

For the preliminary determination of the E 's by the principle of equal effects, equation (127), article seventy-seven, becomes

$$D_1 = D_2 = D_3 = D_4 = D_5 = \frac{R_0}{\sqrt{N}} = \frac{0.0012}{\sqrt{5}} = \pm 0.00054. \quad (\text{ix})$$

Neglecting all factors that do not affect the differential coefficients by more than one unit in the second significant figure and adopting the approximate values of the components given in (v),

$$\left. \begin{aligned} \frac{\partial V}{\partial E_{15}} &= \frac{R_1}{R_2} = \frac{1000}{1310} = 0.76, \\ \frac{\partial V}{\partial \alpha} &= -E_{15}(t-15) \frac{R_1}{R_2} = -5.5, \\ \frac{\partial V}{\partial t} &= -E_{15} \alpha \frac{R_1}{R_2} = -0.00094, \\ \frac{\partial V}{\partial R_1} &= E_{15} \frac{1}{R_2} = 0.0011, \\ \frac{\partial V}{\partial R_2} &= -E_{15} \frac{R_1}{R_2^2} = -0.00083. \end{aligned} \right\} \quad (\text{x})$$

Hence, by combining (viii) and (ix), or directly from equations (128), article seventy-seven,

$$\left. \begin{aligned} E_1 &= \pm \frac{0.00054}{0.76} = \pm 0.00071 \text{ volt}, & (\text{a}) \\ E_2 &= \pm \frac{0.00054}{5.5} = \pm 0.000098, & (\text{b}) \\ E_3 &= \pm \frac{0.00054}{0.00094} = \pm 0^\circ.57 \text{ C.} & (\text{c}) \\ E_4 &= \pm \frac{0.00054}{0.0011} = \pm 0.49 \text{ ohm} & (\text{d}) \\ E_5 &= \pm \frac{0.00054}{0.00083} = \pm 0.65 \text{ ohm.} & (\text{e}) \end{aligned} \right\} \quad (\text{xi})$$

In practice the attainableness of these limits might be determined experimentally; but in the present case, as in most practical problems, general considerations based on theory and previous experience lead to equally trustworthy results. In the first place, it is obvious that the temperature of the Clark cell can be easily determined closer than $0^{\circ}.6$ C. Consequently the limit (c) is easily attainable and might possibly be reduced to a negligible quantity.

The constants of the normal Clark cell are known well within the limits (a) and (b). But it requires very careful treatment of the cell to keep E_{15} constant within the limit (a), and new cells, unless they are set up with great care and skill, are likely to vary among themselves and from the normal cell by more than 0.0007 volt. Consequently the limit (a) is somewhat smaller than is desirable in practical work of the precision considered in the present problem. On the other hand, the limit (b) is very rarely exceeded by either old or new cells unless they are very carelessly constructed and handled. Hence E_2 could probably be reduced to the negligible limit.

With a suitable galvanometer, the nominal values of the resistances R_1 and R_2 can be easily adjusted within the limits (d) and (e). But E_4 and E_5 must be considered practically as the precision measures of R_1 and R_2 . They include the calibration errors of the resistances, the errors due to leakage between the terminals of individual coils, and the errors due to nonuniformity of temperature as well as the errors of setting of the contacts 2 and 3, Fig. 10. The resultant of these errors can be reduced below the limits (d) and (e), but in the present case it would be convenient to have somewhat larger limits in order to reduce the expense of construction and calibration.

Hence, while all of the E 's given by equations (xi) are within attainable limits, the preliminary consideration of minimum expense would be more likely to be fulfilled if the limits (a), (d), and (e) were somewhat larger. Obviously the magnitude of these limits can be increased without violating the primary condition (vii) provided a corresponding decrease in the magnitudes of the limits (b) and (c) is possible.

By equation (131), article seventy-nine, the separate effects D_2 and D_3 will be simultaneously negligible if

$$D_2 = D_3 \cong \frac{1}{3} \frac{R_0}{\sqrt{q}} \cong \frac{1}{3} \frac{0.0012}{\sqrt{2}} \cong \pm 0.00028.$$

Hence, by equations (132), the errors of α and t will be negligible when

$$E_2 \equiv \pm \frac{0.00028}{5.5} \equiv \pm 0.000051, \quad (b')$$

and

$$E_3 \equiv \pm \frac{0.00028}{0.00094} \equiv \pm 0^\circ.30 \text{ C.} \quad (c')$$

Since these limits can be reached with much greater ease than the limits (a), (d), and (e), they may be adopted as final specifications and the corresponding D 's may be omitted during the determination of new limits for the components E_{15} , R_1 , and R_2 .

Under these conditions, equation (ix) becomes

$$D_1 = D_4 = D_5 = \frac{R_0}{\sqrt{N'}} = \frac{0.0012}{\sqrt{3}} = \pm 0.00069.$$

Hence the largest allowable limits for the errors of E_{15} , R_1 , and R_2 are

$$E_1 = \pm \frac{0.00069}{0.76} = \pm 0.00091 \text{ volt}, \quad (a')$$

$$E_4 = \pm \frac{0.00069}{0.0011} = \pm 0.63 \text{ ohm}, \quad (d')$$

$$E_5 = \pm \frac{0.00069}{0.00083} = \pm 0.83 \text{ ohm}. \quad (e')$$

While these limits cannot be quite so easily attained as (b') and (c'), they cannot be increased without violating the primary condition (vii). Consequently they satisfy the condition of minimum expense, so far as the proposed method is concerned, and may be adopted as final specifications.

The fractional errors corresponding to the specified precision measure of V and the above limiting errors of the components are

$$P_0 = \frac{R_0}{V} = \pm 0.0011 = \pm 0.11\%,$$

$$P_1 = \frac{E_1}{E_{15}} = \pm 0.00063 = \pm 0.063\%,$$

$$P_2 = \frac{E_2}{\alpha} = \pm 0.059 = \pm 5.9\%,$$

$$P_3 = \frac{E_3}{t} = \pm 0.015 = \pm 1.5\%,$$

$$P_4 = \frac{E_4}{R_1} = \pm 0.00063 = \pm 0.063\%,$$

$$P_5 = \frac{E_5}{R_2} = \pm 0.00063 = \pm 0.063\%.$$

Consequently in order to obtain a value of V that is exact within 0.11 per cent by the proposed method, α must be determined within 5.9 per cent, t within 1.5 per cent, and E_{15} , R_1 , and R_2 , each within 0.063 per cent. These limits are all attainable in practice under suitable conditions, as pointed out above. Hence the proposed method is practicable.

If the final measurements are so devised and executed that the above conditions are fulfilled, the precision of the result computed from them will be within the specified limits and the expense of the work will be reduced to the lowest limit compatible with the proposed method. The desired result might be obtained at less expense by some other method, but a decision on this point can be reached only by comparing the precision requirements and practicability of various methods with the aid of analyses similar to the above.

CHAPTER XII.

BEST MAGNITUDES FOR COMPONENTS.

82. Statement of the Problem. — The precision of a derived quantity depends on the relative magnitudes and precision of the components from which it is computed, as explained in Chapter VIII. Thus, if the derived quantity x_0 is given in terms of the components x_1, x_2, \dots, x_q by the expression

$$x_0 = F(x_1, x_2, \dots, x_q), \quad (144)$$

the probable error of x_0 is given by the expression

$$E_0^2 = S_1^2 E_1^2 + S_2^2 E_2^2 + \dots + S_q^2 E_q^2, \quad (145)$$

where the E 's represent the probable errors of the x 's with corresponding subscripts, and

$$S_1 = \frac{\partial F}{\partial x_1}; \quad S_2 = \frac{\partial F}{\partial x_2}; \quad \dots; \quad S_q = \frac{\partial F}{\partial x_q}. \quad (146)$$

The error E , corresponding to any directly measured component, is generally, but not always, independent of the absolute magnitude of that component so long as the measurements are made by the same method and apparatus. For example: the probable error of a single measurement with a micrometer caliper, graduated to 0.01 millimeter, is approximately equal to 0.004 millimeter, whatever the magnitude of the object measured so long as it is within the range of the instrument. Hence, when the methods and instruments to be used in measuring each of the components are known in advance, the probable errors E_1, E_2 , etc., can be determined, at least approximately, by preliminary measurements on quantities of the same kind as the components but of any convenient magnitude. Under these conditions the E 's on the right-hand side of equation (145) may be treated as known constants, and, since the S 's are expressible in terms of x_1, x_2 , etc., by equations (146), the value of E_0 corresponding to the given methods cannot be changed without a simultaneous change in the relative or absolute magnitudes of the components.

Since equation (144) must always be fulfilled, and since the value of x_0 is usually fixed by the conditions of the problem, a change in the magnitudes of the x 's is not always possible. But it frequently happens that the form of the function F is such that the relative magnitudes of the components can be changed through somewhat wide limits and still satisfy equation (144). Thus, if a cylinder is to have a specified volume, it may be made long and thin, or short and thick, and have the same volume in either case. Consequently it is sometimes possible to select magnitudes for the components that will give a minimum value of E_0 and at the same time satisfy equation (144).

The problem before us may be briefly stated as follows: Having given definite methods and apparatus for the measurement of the components of a derived quantity x_0 , what magnitudes of the components will give a minimum value to the probable error E_0 of x_0 and at the same time satisfy the functional relation (144)?

It can be easily seen that a practical solution of this problem is not always possible. In the first place the form of the function F may be such as to admit of but a single system of magnitudes of the components, and consequently the value of E_0 is definitely fixed by equation (145). In some cases there are no real values of the x 's that will satisfy both (144) and the conditions for a minimum of E_0 . When values can be found that satisfy the mathematical conditions they are not always attainable in practice. Finally the probable errors E_1, E_2 , etc., may not be independent of the magnitudes of the corresponding components or it may be impossible to determine them in advance of the final measurements.

When the E 's are not independent of the x 's it sometimes happens that the fractional errors

$$P_1 = \frac{E_1}{x_1}; \quad P_2 = \frac{E_2}{x_2}; \quad \dots; \quad P_q = \frac{E_q}{x_q} \quad (147)$$

are constant and determinable in advance. In such cases the problem may be solvable by putting (145) in the equivalent form

$$E_0^2 = S_1^2 P_1^2 x_1^2 + S_2^2 P_2^2 x_2^2 + \dots + S_q^2 P_q^2 x_q^2, \quad (148)$$

expressing the S 's in terms of the components by equations (146), and determining the values of the x 's that will render (148) a minimum subject to the condition (144).

aid of equation (145), but it is sometimes necessary to apply the well-known criteria of the calculus.

Dividing equation (145) by x_0^2 and putting

$$T_1 = \frac{S_1}{x_0} = \frac{1}{x_0} \frac{\partial F}{\partial x_1}; \quad T_2 = \frac{S_2}{x_0} = \frac{1}{x_0} \frac{\partial F}{\partial x_2}; \quad \dots; \quad T_q = \frac{S_q}{x_0} = \frac{1}{x_0} \frac{\partial F}{\partial x_q} \quad (150)$$

gives the expression

$$P_0^2 = \frac{E_0^2}{x_0^2} = T_1^2 E_1^2 + T_2^2 E_2^2 + \dots + T_q^2 E_q^2 \quad (151)$$

for the fractional error of x_0 . Since x_0 is a constant in any given problem the maxima and minima of P_0^2 correspond to the same values of the components as those of E_0^2 . Sometimes the form of the function F is such that the expression (151), when expanded in terms of the x 's, is much simpler than (145). In such cases it is much easier to determine the minima of P_0^2 than of E_0^2 . For this purpose the equations of condition (i) may be put in the form

$$\left. \begin{aligned} \frac{\partial P_0^2}{\partial x_1} - 2 \frac{K}{x_0} \frac{\partial F}{\partial x_1} &= 0, \\ \frac{\partial P_0^2}{\partial x_2} - 2 \frac{K}{x_0} \frac{\partial F}{\partial x_2} &= 0, \\ \dots &\dots \\ \frac{\partial P_0^2}{\partial x_q} - 2 \frac{K}{x_0} \frac{\partial F}{\partial x_q} &= 0, \end{aligned} \right\} \quad (152)$$

and by substitution and transposition we have

$$\left. \begin{aligned} T_1 \frac{\partial T_1}{\partial x_1} E_1^2 + T_2 \frac{\partial T_2}{\partial x_1} E_2^2 + \dots + T_q \frac{\partial T_q}{\partial x_1} E_q^2 &= K T_1, \\ T_1 \frac{\partial T_1}{\partial x_2} E_1^2 + T_2 \frac{\partial T_2}{\partial x_2} E_2^2 + \dots + T_q \frac{\partial T_q}{\partial x_2} E_q^2 &= K T_2, \\ \dots &\dots \\ T_1 \frac{\partial T_1}{\partial x_q} E_1^2 + T_2 \frac{\partial T_2}{\partial x_q} E_2^2 + \dots + T_q \frac{\partial T_q}{\partial x_q} E_q^2 &= K T_q. \end{aligned} \right\} \quad (153)$$

When the components are required to satisfy the condition (144) and a given constant value is assigned to x_0 , equations (153) lead to exactly the same results as equations (149). In fact either of these sets of equations can be derived from the other by purely algebraic methods when the S 's and T 's are expressed in terms of the x 's. In practice one or the other of the sets will be the simpler, depending on the form of the function F ; and the simpler form

can be more easily derived by direct methods as above than by algebraic transformation.

In some problems the magnitude of one or more of the components in the function F can be varied at will and determined with such precision that their probable errors are negligible in comparison with those of the other components. Variables that fulfill these conditions will be called *free components*. Since any convenient magnitude can be assigned to them, their values can always be so chosen that the condition (144) will be fulfilled whatever the values of the other components. Consequently the latter components may be treated as independent variables in determining the minima of E_0^2 or P_0^2 .

Under these conditions the E 's corresponding to the free components can be placed equal to zero, and either E_0^2 or P_0^2 can sometimes be expressed as a function of independent variables only by eliminating the free components from the S 's or the T 's with the aid of equation (144). When this elimination can be effected, the minimum conditions may be derived from equations (149) or (153), as the case may be, by placing K equal to zero and omitting the equations involving derivatives with respect to the free components. This is evident because the remaining components are entirely independent, and consequently the partial derivatives of E_0^2 or P_0^2 with respect to each of them must vanish when the values of the variables correspond to the maxima or minima of these functions. When the elimination cannot be accomplished, neither equations (149) nor (153) will lead to consistent results and the problem is generally insolvable.

In practice it frequently happens that the free components are factors of the function F , and are not included in any other way. Under these conditions they do not occur in the T 's corresponding to the remaining components, since the form of equations (150) is such that they are automatically eliminated. Consequently, in this case, the conditions for a minimum are given at once by equations (153) when K is taken equal to zero, since the derivatives with respect to the free components all vanish and the corresponding E 's are negligible. It is scarcely necessary to point out that the remarks in the paragraph following equations (149), except for obvious changes in notation, apply with equal rigor to equations (153), whether K is zero or finite. The values of the x 's derived from these equations should never be assumed to correspond to the minima of P_0^2 without further investigation.

84. **Special Cases.** — Suppose that the relation between the derived quantity x_0 and the measured components x_1 , x_2 , and x_3 is given in the form

$$x_0 = ax_1^{n_1} + bx_2^{n_2} + cx_3^{n_3}, \quad (\text{ii})$$

where a , b , c , and the n 's are constants. If the probable errors E_1 , E_2 , and E_3 of the x 's with corresponding subscripts are known, and independent of the magnitude of the components, what magnitudes of the components will give the least possible value to the probable error E_0 of x_0 ?

By equations (146),

$$S_1 = an_1x_1^{(n_1-1)}; \quad S_2 = bn_2x_2^{(n_2-1)}; \quad S_3 = cn_3x_3^{(n_3-1)}. \quad (\text{iii})$$

Consequently

$$\frac{\partial S_1}{\partial x_1} = an_1(n_1 - 1)x_1^{(n_1-2)}; \quad \frac{\partial S_2}{\partial x_1} = 0; \quad \frac{\partial S_3}{\partial x_1} = 0,$$

$$\frac{\partial S_1}{\partial x_2} = 0; \quad \frac{\partial S_2}{\partial x_2} = bn_2(n_2 - 1)x_2^{(n_2-2)}; \quad \frac{\partial S_3}{\partial x_2} = 0,$$

$$\frac{\partial S_1}{\partial x_3} = 0; \quad \frac{\partial S_2}{\partial x_3} = 0; \quad \frac{\partial S_3}{\partial x_3} = cn_3(n_3 - 1)x_3^{(n_3-2)}.$$

Substituting these results in equations (149) and dividing the first equation by S_1 , the second by S_2 , and the third by S_3 , the conditions for a minimum value of E_0^2 become

$$E_1^2 an_1(n_1 - 1)x_1^{(n_1-2)} = K,$$

$$E_2^2 bn_2(n_2 - 1)x_2^{(n_2-2)} = K,$$

$$E_3^2 cn_3(n_3 - 1)x_3^{(n_3-2)} = K.$$

Dividing the second and third of these equations by the first and transposing the coefficients to the second member gives the ratios of the components in the form

$$\left. \begin{aligned} \frac{x_2^{(n_2-2)}}{x_1^{(n_1-2)}} &= \frac{E_1^2 an_1(n_1 - 1)}{E_2^2 bn_2(n_2 - 1)}, \\ \frac{x_3^{(n_3-2)}}{x_1^{(n_1-2)}} &= \frac{E_1^2 an_1(n_1 - 1)}{E_3^2 cn_3(n_3 - 1)}. \end{aligned} \right\} \quad (\text{iv})$$

These two equations together with (ii) are theoretically sufficient for the determination of the best magnitudes for the three components x_1 , x_2 , and x_3 ; but it can be easily seen, from the form of the equations, that a solution is not practicable for all possible values of the n 's.

For example, if the n 's are all equal to unity, the ratios of the components given by (iv) are both indeterminate, each being equal to $\frac{0}{0}$. Consequently the problem has no solution in this case. This conclusion might have been reached at once by inspecting the value of E_0^2 given by equation (145), when the S 's are expressed in terms of the components. Thus, placing the n 's equal to unity in equations (iii) and substituting the results in (145), we find

$$E_0^2 = a^2 E_1^2 + b^2 E_2^2 + c^2 E_3^2.$$

Since E_0^2 is independent of the x 's it can have no maxima or minima with respect to the components.

When each of the n 's equals two, equations (iv) are independent of the x 's, and consequently the problem is not solvable. In this case (ii) becomes

$$x_0 = ax_1^2 + bx_2^2 + cx_3^2,$$

and (145) reduces to

$$E_0^2 = 4a^2 x_1^2 E_1^2 + 4b^2 x_2^2 E_2^2 + 4c^2 x_3^2 E_3^2.$$

Since these equations differ only in the values of the constant coefficients of the x 's, no magnitudes can be assigned to the components that will give a minimum value to E_0^2 , and at the same time satisfy the equation for x_0 .

If each of the n 's is placed equal to three, equation (ii) takes the form

$$x_0 = ax_1^3 + bx_2^3 + cx_3^3, \quad (\text{v})$$

and equations (iv) become

$$\left. \begin{aligned} \frac{x_2}{x_1} &= \frac{aE_1^2}{bE_2^2}, \\ \frac{x_3}{x_1} &= \frac{aE_1^2}{cE_3^2}. \end{aligned} \right\} \quad (\text{iv}')$$

In this case the problem can be easily solved when the numerical values of the coefficients and the E 's are known. As a very simple illustration, suppose that

$$a = b = c = 1, \quad \text{and} \quad E_1 = E_2 = E_3 = E,$$

then, by (iv') and (v),

$$[x_1^3 = x_2 = x_3 = \left(\frac{x_0}{3}\right)^{\frac{1}{3}},$$

and, by (145) and (iii),

$$E_0^2 = 9(x_1^4 + x_2^4 + x_3^4) E^2.$$

Since a decrease in the magnitude of one of the x 's involves an increase in that of one or both of the others, in order to satisfy equation (v), and since the fourth power of a quantity varies more rapidly than the third, it is obvious that the minimum value of E_0^2 will occur when the x 's are all equal. Consequently the above solution corresponds to a minimum of E_0^2 .

It can be easily seen that there are many other cases in which equations (ii) and (iv) can be solved, and also some others in which no solution is possible. The extension of the problem to functions in the same form as equation (ii), but containing any number of similar terms, involves only the addition of one equation in the form of (iv) for each added component. Obviously these equations hold for negative as well as positive values of the coefficients and exponents of the x 's.

As a second example, consider the functional relation

$$x_0 = ax_1^{n_1} \times x_2^{n_2}. \quad (\text{vi})$$

In this case the solution is more easily effected by the second method given in the preceding article. By equations (150)

$$T_1 = \frac{n_1}{x_1}; \quad T_2 = \frac{n_2}{x_2}. \quad (\text{vii})$$

Consequently

$$\begin{aligned} \frac{\partial T_1}{\partial x_1} &= -\frac{n_1}{x_1^2}; \quad \frac{\partial T_2}{\partial x_1} = 0; \\ \frac{\partial T_1}{\partial x_2} &= 0; \quad \frac{\partial T_2}{\partial x_2} = -\frac{n_2}{x_2^2}, \end{aligned}$$

and equations (153) reduce to the simple form

$$\frac{n_1}{x_1^2} E_1^2 = -K; \quad \frac{n_2}{x_2^2} E_2^2 = -K, \quad (\text{viii})$$

where E_1 and E_2 are the known constant probable errors of x_1 and x_2 . Eliminating K , we have

$$\frac{x_2^2}{x_1^2} = \frac{n_2}{n_1} \cdot \frac{E_2^2}{E_1^2}.$$

Consequently the problem is always solvable when n_1 and n_2 have the same sign. When they have different signs the solution is imaginary. Hence there are no best magnitudes for the components when the derived quantity is given as the ratio of two measured quantities.

The extension of this solution to functions involving any number of factors is obvious. When the exponents of all of the factors have the same sign the problem is always solvable but the best magnitudes thus found may not be attainable in practice. If part of the exponents are positive and others are negative the solution is imaginary.

85. Practical Examples.

I.

In many experiments the desired result depends directly upon the determination of the quantity of heat generated by an electric current in passing through a resistance coil. Let I represent the current intensity and E the fall of potential between the terminals of the coil. Then the quantity of heat H developed in t seconds may be computed by the relation

$$JH = IEt,$$

where J represents the mechanical equivalent of heat. If H is measured in calories, I in amperes, E in volts, and t in seconds, $\frac{1}{J}$ is equal to 0.239 calorie per Joule and the above relation becomes

$$H = 0.239 \cdot IEt. \quad (\text{ix})$$

Suppose that the conditions of the problem in hand are such that H should be made approximately equal to 1000 calories. Since the resistance of the heating coil is not specified it can be so chosen that I and E may have any convenient values that satisfy the relation (ix) when H has the above value. Obviously t can be varied at will, by changing the time of run, and (ix) will not be violated if suitable values are assigned to I and E . If the instruments available for measuring I , E , and t are an ammeter graduated to tenths of an ampere, a voltmeter graduated to tenths of a volt, and a common watch with a seconds hand, what are the best magnitudes that can be assigned to the components, i.e., what magnitudes of I , E , and t will give the computed H with the least probable error?

By comparing equations (ix) and (vi), it is easy to see that the present problem is an application of the second special case worked out in the preceding article when a third variable factor $x_3^{n_3}$ is annexed to (vi). H corresponds to x_0 , I to x_1 , E to x_2 , t to x_3 , and all of the n 's in (vi) are equal to unity. Consequently

the solution can be derived at once from three equations in the form of (viii) if suitable values can be assigned to the probable errors of the components.

With the available instruments, the probable errors E_i , E_e , and E_t of I , E , and t , respectively, will be practically independent of the magnitude of the measured quantities so long as the range of the instruments is not exceeded. Under the conditions that usually prevail in such observations the following precision may be attained with reasonable care:

$$E_i = 0.05 \text{ ampere; } E_e = 0.05 \text{ volt; } E_t = 1 \text{ second.}$$

The conditions for a minimum value of the probable error E_0 of H can be derived by exactly the same method that was used in obtaining equations (viii), or these equations may be used at once with proper substitutions as outlined above. Consequently the best magnitudes for the components are given by the simultaneous solution of (ix) and the following three equations,

$$\frac{E_i^2}{I^2} = -K; \quad \frac{E_e^2}{E^2} = -K; \quad \frac{E_t^2}{t^2} = -K$$

Eliminating K and substituting the numerical values of the probable errors we have

$$\frac{E}{I} = \frac{E_e}{E_i} = 1; \quad \frac{t}{I} = \frac{E_t}{E_i} = 20.$$

Consequently

$$E = I \quad \text{and} \quad t = 20 \cdot I. \quad (x)$$

Substituting these results and the numerical value of H in (ix) we have

$$1000 = 0.239 \times 20 \times I^3,$$

and hence

$$I = 5.94 \text{ amperes}$$

is the best magnitude to assign to the current strength under the given conditions. The corresponding magnitudes for the electromotive force and time found by (x) are

$$E = 5.94 \text{ volts and } t = 119 \text{ seconds.}$$

If the above values of the components and their probable errors are substituted in equation (151), the fractional error of H comes out

$$P_0^2 = \left(\frac{0.05}{5.94}\right)^2 + \left(\frac{0.05}{5.94}\right)^2 + \left(\frac{1}{119}\right)^2 = 212 \times 10^{-6},$$

and the probable error of H is given by the relation

$$E_0 = 1000 P_0 = \pm 15 \text{ calories.}$$

If any other magnitudes for the components, that satisfy equation (ix), are used in place of the above in (151), the computed value of E_0 will be greater than fifteen calories. Consequently the above solution corresponds to a minimum value of E_0 .

In order to fulfill the above conditions the resistance of the heating coil must be so chosen as to satisfy the relation

$$R = \frac{E}{I}.$$

Since our solution calls for numerically equal values of I and E , the resistance R must be made equal to one ohm.

It can be easily seen that small variations in the values of the components will produce no appreciable effect on the probable error of H , since the numerical value of E_0 is never expressed by more than two significant figures. Consequently the foregoing discussion leads to the following practical suggestions regarding the conduct of the experiment. The heating coil should be so constructed that the heat developed in the leads is negligible in comparison with that developed between the terminals of the voltmeter. The resistance of the coil should be one ohm. The current strength should be adjusted to approximately six amperes and allowed to flow continuously for about two minutes. Under these conditions the difference in potential between the terminals of the coil will be about six volts. The conditions under which I , E , and t are observed should be so chosen that the probable errors specified above are not exceeded.

If the above suggestions are carried out in practice the value of H computed from the observed values of I , E , and t by equation (ix) will be approximately 1000 calories, and its probable error will be about fifteen calories. A more precise result than this cannot be obtained with the given instruments unless the probable errors of I , E , and t can be materially decreased by modifying the conditions and methods of observation.

II.

A partial discussion of the problem of finding the best magnitudes for the components involved in the measurement of the strength of an electric current with a tangent galvanometer may

be found in many laboratory manuals and textbooks. Such discussions are usually confined to a consideration of the error in the computed current strength due to a given error in the observed deflection. On the assumption, tacit or expressed, that the effects of the errors of all other components are negligible it is proved that the effect of the deflection error is a minimum when the deflection is about forty-five degrees. Although the tangent galvanometer is now seldom used in practice it provides an instructive example in the calculation of best magnitudes since the general bearings of the problem are already familiar to most students.

In order to avoid unnecessary complications, consider a simple form of instrument with a compass needle whose position is observed directly on a circle graduated in degrees. Suppose that the needle is pivoted at the center of a single coil of N turns of wire, and R centimeters mean radius. Under these conditions the current strength I is connected with the observed deflection ϕ by the relation

$$I = \frac{HR}{2\pi N} \tan \phi,$$

where H is the horizontal intensity of a uniform external magnetic field parallel to the plane of the coil. In practice the plane of the coil is usually placed parallel to the magnetic meridian and H is taken equal to the horizontal component of the earth's magnetism.

N is an observed component but it can be so precisely determined by direct counting, during the construction of the coil, that its error may be considered negligible in comparison with those of the other components. Furthermore it can be given any desired value when an instrument is designed to meet special needs, and a choice among a number of different values is possible in most completed instruments. Consequently the quantity $\frac{1}{2\pi N}$ may be treated as a free component, represented by A , and the expression for the current strength may be written in the form

$$I = AHR \cdot \tan \phi. \quad (\text{xi})$$

Comparing this expression with the general equation (144) we note that I corresponds to x_0 , H to x_1 , R to x_2 , and ϕ to x_3 .

Since A is free, the components H , R , and ϕ are entirely independent; and any convenient magnitudes can be made to satisfy

(xi) by suitably choosing the number of turns in the coil. Consequently, as pointed out in article eighty-three with respect to functions containing a free component as a factor, the conditions for a minimum probable error of I are given by equations (153) with K placed equal to zero. By making the above substitutions for the x 's in equations (150) and performing the differentiations we have

$$T_1 = \frac{1}{H}; \quad T_2 = \frac{1}{R}; \quad T_3 = \frac{2}{\sin 2\phi}. \quad (\text{xii})$$

Consequently

$$\begin{aligned} \frac{\partial T_1}{\partial H} &= -\frac{1}{H^2}; & \frac{\partial T_2}{\partial H} &= 0; & \frac{\partial T_3}{\partial H} &= 0; \\ \frac{\partial T_1}{\partial R} &= 0; & \frac{\partial T_2}{\partial R} &= -\frac{1}{R^2}; & \frac{\partial T_3}{\partial R} &= 0; \\ \frac{\partial T_1}{\partial \phi} &= 0; & \frac{\partial T_2}{\partial \phi} &= 0; & \frac{\partial T_3}{\partial \phi} &= -\frac{4 \cos 2\phi}{\sin^2 2\phi}, \end{aligned}$$

and, if the probable errors of H , R , and ϕ are represented by E_1 , E_2 , and E_3 , respectively, equations (153) become

$$\frac{E_1^2}{H^3} = 0; \quad \frac{E_2^2}{R^3} = 0; \quad 8 E_3^2 \frac{\cos 2\phi}{\sin^3 2\phi} = 0. \quad (\text{xiii})$$

If E_1 and E_2 could be made negligible, as is tacitly assumed in most discussions of the present problem, the first two of equations (xiii) would be satisfied whatever the values of H and R . Consequently these components would be free and ϕ would be the only independent variable involved in equation (xi). Under these conditions the minimum value of the probable error of I corresponds to the value of ϕ derived from the third of equations (xiii). The general solution of this equation is

$$\phi = (2n - 1) \frac{\pi}{4},$$

where n represents any integer. But, since values of ϕ greater than $\frac{\pi}{2}$ are not attainable in practice, n must be taken equal to unity in the present case and consequently the best magnitude for the deflection is forty-five degrees. It is obvious that (xi) can always be satisfied when I has any given value, and ϕ is equal to forty-five degrees by suitably choosing the values of the free components N , H , and R .

If the fractional error of I is represented by P_0 and the T 's given by equations (xii) are substituted in (151),

$$\left. \begin{aligned} P_0^2 &= \frac{E_1^2}{H^2} + \frac{E_2^2}{R^2} + \frac{4E_3^2}{\sin^2 2\phi} \\ &= P_1^2 + P_2^2 + P_3^2, \end{aligned} \right\} \quad (\text{xiv})$$

where

$$P_1 = \frac{E_1}{H}; \quad P_2 = \frac{E_2}{R}; \quad \text{and} \quad P_3 = \frac{2E_3}{\sin 2\phi}$$

are the separate effects of the probable errors E_1 , E_2 , and E_3 , respectively. If both ends of the needle are read with direct and reversed current so that ϕ represents the mean of four observations, E_3 should not exceed $0^\circ.025$ or 0.00044 radians, and it might be made less than this with sufficient care. Consequently, when ϕ is equal to forty-five degrees,

$$P_3 = 0.00088.$$

By an argument similar to that given in article seventy-nine it can be proved that P_1 and P_2 will be simultaneously negligible when they satisfy the condition

$$P_1 = P_2 \cong \frac{1}{3} \frac{P_3}{\sqrt{2}} \cong 0.00021.$$

Hence, in order that the effects of E_1 and E_2 may be negligible in comparison with that of E_3 , H and R must be determined within about two one-hundredths of one per cent.

With an instrument of the type considered it would seldom be possible and never worth while to determine H and R with the precision necessary to fulfill the above condition. In common practice E_1 and E_2 are generally far above the negligible limit and it would be necessary to make both H and R equal to infinity in order to satisfy the first two of the minimum conditions (xiii). Hence there is no practically attainable minimum value of P_0 . This conclusion can also be derived directly by inspection of equation (xiv). P_0^2 decreases uniformly as H and R are increased, and becomes equal to P_3^2 when they reach infinity.

Although a minimum value of P_0 is not attainable, the foregoing discussion leads to some practical suggestions regarding the design and use of the tangent galvanometer. For any given values of E_1 , E_2 , and E_3 , the minimum value of P_3 occurs when ϕ is equal to forty-five degrees. Also P_1 and P_2 decrease as H and R increase. Consequently the directive force H and the radius

of the coil R should be made as large as is consistent with the conditions under which the instrument is to be used, and the number of turns N in the coil should be so chosen that the observed deflection will be about forty-five degrees.

The practical limit to the magnitude of R is generally set by a consideration of the cost and convenient size of the instrument. Moreover when R is increased N must be increased in like ratio in order to satisfy the fundamental relation (xi) without altering the observed deflection or decreasing the value of H . There is an indefinite limit beyond which N cannot be increased without introducing the chance of error in counting and greatly increasing the difficulty of determining the exact magnitude of R . Above this limit E_2 is approximately proportional to R , and, as can be easily seen by equation (xiv), there is no advantage to be gained by a further increase in the magnitude of R .

H can be varied by suitably placed permanent magnets, but it is difficult to maintain strong magnetic fields uniform and constant within the required limits. Even under the most favorable conditions, the exact determination of H is very tedious and involves relatively large errors. Consequently P_1^2 is likely to be the largest of the three terms on the right-hand side of equation (xiv). Under suitable conditions it can be reduced in magnitude by increasing H to the limit at which the value of E_1 begins to increase. However, such a procedure involves an increased value of N in order to satisfy equation (xi), and consequently it may cause an increase in E_2 owing to the relation between N and R pointed out in the preceding paragraph. In such a case the gain in precision due to a decreased value of P_1 would be nearly balanced by an increased value of P_2 .

In common practice the instrument is so adjusted that H is equal to the horizontal component of the earth's magnetic field at the time and place of observation. Unless H is very carefully determined at the exact location of the instrument, E_1 is likely to be as large as $0.005 \frac{\text{dyne}}{\text{cm}^2}$, and, since the order of magnitude of H is about $0.2 \frac{\text{dyne}}{\text{cm}^2}$, P_1 will be approximately equal to 0.025. Hence both P_2 and P_3 will be negligible in comparison with P_1 if they satisfy the relation

$$P_2 = P_3 \cong \frac{1}{3} \cdot \frac{P_1}{\sqrt{2}} \cong 0.0059.$$

Under ordinary conditions R and ϕ can be easily determined within the above limit. Consequently, in the supposed case,

$$P_0 = P_1 = 2.5 \text{ per cent,}$$

and it would be useless to attempt an improvement in precision by adjusting the values of N , R , and ϕ . With sufficient care in determining H , P_1 can be reduced to such an extent that it becomes worth while to carry out the suggestions regarding the design and use of the instrument given by the foregoing theory. But when the value of H is assumed from measurements made in a neighboring location or is taken from tables or charts the percentage error of I will be nearly equal to that of H regardless of the adopted values of R and ϕ . Under such conditions P_0 cannot be exactly determined but it will seldom be less than two or three per cent of the measured magnitude of I .

The above problem has been discussed somewhat in detail in order to illustrate the inconsistent results that are likely to be obtained in determining best magnitudes when the effects of the errors of some of the components are neglected. It is never safe to assume that the error of a component is negligible until its effect has been compared with that of the errors of the other components.

III.

Figure eleven is a diagram of the apparatus and connections commonly used in determining the internal resistance of a battery by the condenser method. G is a ballistic galvanometer, C a condenser, R a known resistance, K_1 a charge and discharge key, K_2 a plug or mercury key, and B a battery to be tested.

Let x_1 represent the ballistic throw of the galvanometer when the condenser is charged and discharged with the key K_2 open, and x_2 the corresponding throw when K_2 is closed. Then the internal resistance R_0 of the battery may be computed by the relation

$$R_0 = R \frac{x_1 - x_2}{x_2}. \quad (\text{xv})$$

Under ordinary conditions the probable errors of x_1 and x_2 cannot be made much less than one-half of one per cent of the observed throws when a telescope, mirror, and scale are used. On the other hand the probable error of R should not exceed one-tenth of one per cent if a suitably calibrated resistance is used and the

connections are carefully made. When these conditions are fulfilled, it can be easily proved that the effect of the error of R is negligible in comparison with that of the errors of x_1 and x_2 . Furthermore any convenient value can be assigned to R , such

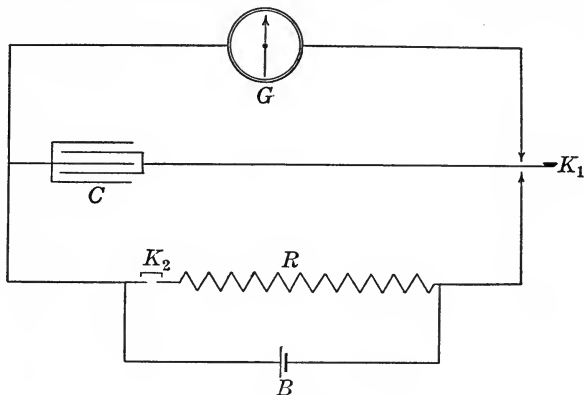

FIG. 11.

that (xv) will be satisfied whatever the values of x_1 and x_2 . Consequently R may be treated as a free component and the throws x_1 and x_2 as independent variables.

For the purpose of determining the magnitudes of the components R , x_1 , and x_2 that correspond to a minimum value of the fractional error P_0 of R_0 , we have by equations (150) and (xv)

$$T_1 = \frac{1}{x_1 - x_2}; \quad T_2 = -\frac{x_1}{x_2(x_1 - x_2)}. \tag{xvi}$$

Consequently

$$\frac{\partial T_1}{\partial x_1} = -\frac{1}{(x_1 - x_2)^2}; \quad \frac{\partial T_2}{\partial x_1} = \frac{1}{(x_1 - x_2)^2},$$

$$\frac{\partial T_1}{\partial x_2} = \frac{1}{(x_1 - x_2)^2}; \quad \frac{\partial T_2}{\partial x_2} = \frac{x_1^2 - 2x_1x_2}{x_2^2(x_1 - x_2)^2}.$$

Since x_1 and x_2 are independent, K must be taken equal to zero in the minimum conditions (153). Hence, dividing the first two equations by T_1 , we have

$$-\frac{1}{(x_1 - x_2)^2} E_1^2 - \frac{x_1}{x_2} \cdot \frac{1}{(x_1 - x_2)^2} E_2^2 = 0,$$

$$\frac{1}{(x_1 - x_2)^2} E_1^2 - \frac{x_1}{x_2} \cdot \frac{x_1^2 - 2x_1x_2}{x_2^2(x_1 - x_2)^2} E_2^2 = 0,$$

where E_1 and E_2 are the probable errors of x_1 and x_2 , respectively.

Multiply each of these equations by $-\frac{(x_1 - x_2)^2}{E_2^2}$ and they assume the simple form

$$\frac{x_1}{x_2} + \frac{E_1^2}{E_2^2} = 0, \quad (a)$$

$$\frac{x_1^3}{x_2^3} - 2\frac{x_1^2}{x_2^2} - \frac{E_1^2}{E_2^2} = 0. \quad (b)$$

Since E_1^2 and E_2^2 are always positive, it is obvious that there are no values of x_1 and x_2 that will satisfy both of these equations at the same time. Hence, when x_1 and x_2 can be varied independently, they cannot be so chosen that the fractional error P_0 will be a minimum. However, if x_2 is kept constant at any assigned value, P_0 will pass through a minimum when x_1 satisfies equation (a). On the other hand if any constant value is assigned to x_1 the minima and maxima of P_0 will correspond to the roots of equation (b).

In practice x_1 is the throw of the galvanometer needle due to the electromotive force of the battery when on open circuit; and it is very nearly constant, during a series of observations, when suitable precautions are taken to avoid the effects of polarization. Both x_1 and x_2 can be varied by changing the capacity of the condenser or the sensitiveness of the galvanometer, but their ratio depends only on the ratio of R_0 to R . Consequently, if any convenient magnitude is assigned to x_1 , the root of equation (b) that corresponds to a minimum value of P_0 gives the best magnitude for the component x_2 .

Since x_1 and x_2 are similar quantities, determined with the same instruments and under the same conditions, E_1 is generally equal to E_2 . Hence, if we replace the ratio $\frac{x_1}{x_2}$ by y , equation (b) becomes

$$y^3 - 2y^2 - 1 = 0. \quad (b')$$

The only real root of this equation is

$$y = 2.2056.$$

By equations (151) and (xvi)

$$P_0^2 = \frac{E_1^2}{(x_1 - x_2)^2} + \frac{x_1^2 E_2^2}{x_2^2 (x_1 - x_2)^2}.$$

Putting

$$E_1 = E_2 = E \quad \text{and} \quad \frac{x_1}{x_2} = y,$$

$$\frac{P_0^2}{E^2} = \frac{y^2 + y^4}{x_1^2 (y - 1)^2}.$$

Since x_1 is necessarily greater than x_2 , y cannot be less than unity. Under this condition it can be easily proved by trial that $\frac{P_0^2}{E^2}$ approaches a minimum as y approaches the value given above, provided any constant value is assigned to x_1 .

Equation (xv) may be put in the form

$$R_0 = R(y - 1),$$

and, by introducing the value of y given by the minimum condition (b'), we have

$$R = 0.83 R_0.$$

Consequently the greatest attainable precision in the determination of R_0 will be obtained when R is made equal to about eighty three per cent of R_0 . If R is adjusted to this value x_1 and x_2 will satisfy equation (b), whatever the magnitude of the capacity used, provided the observations are so made that E_1 and E_2 are equal.

When the internal resistance of the battery is very low it is sometimes impracticable to fulfill the above theoretical conditions because the errors due to polarization are likely to more than offset the gain in precision corresponding to the theoretically best magnitudes of the components. In such cases a high degree of precision is not attainable, but it is generally advisable to make R considerably larger than R_0 in order to reduce polarization errors.

86. Sensitiveness of Methods and Instruments.—The precision attainable in the determination of directly measured components depends very largely on the sensitiveness of indicating instruments and on the methods of adjustment and observation. The design and construction of an instrument fixes its intrinsic sensitiveness; but its effective sensitiveness, when used as an indicating device, depends on the circumstances under which it is used and is frequently a function of the magnitudes of measured quantities and other determining factors. Thus; the intrinsic sensitiveness of a galvanometer is determined by the number of windings in the coils, the moment of the directive couple, and various other factors that enter into its design and construction. On the other hand its effective sensitiveness as an indicator in a Wheatstone Bridge is a function of the resistances in the various arms of the bridge and the electromotive force of the battery used. An increase in the intrinsic sensitiveness of an instrument may cause an increase or a decrease in its effective sensitiveness,

depending on the nature of the corresponding modification in design and the circumstances under which the instrument is used.

By a suitable choice of the magnitudes of observed components and other determining factors it is sometimes possible to increase the effective sensitiveness of indicating instruments and hence also the precision of the measurements. On the other hand, as pointed out in Chapter XI, the precision of measurements should not be greater than that demanded by the use to which they are to be put. In all cases the effective sensitiveness of instruments and methods should be adjusted to give a result definitely within the required precision limits determined as in Chapter XI. Consequently the best magnitudes for the quantities that determine the effective sensitiveness are those that will give the required precision with the least labor and expense. The methods by which such magnitudes can be determined depend largely on the nature of the problem in hand, and a general treatment of them is quite beyond the scope of the present treatise. Each separate case demands a somewhat detailed discussion of the theory and practice of the proposed measurements and only a single example can be given here for the purpose of illustration.

Since the potentiometer method of comparing electromotive forces has been quite fully discussed in article eighty-one, it will be taken as a basis for the illustration and we will proceed to find the relation between the effective sensitiveness of the galvanometer and the various resistances and electromotive forces involved. Since the directly observed components in this method are the resistances R_1 and R_2 , the effective sensitiveness is equal to the galvanometer deflection corresponding to a unit fractional deviation of R_1 or R_2 from the condition of balance.

From the discussion given in article eighty-one it is evident that the potentiometer method could be carried out with any convenient values of the resistances R_1 and R_2 provided they are so adjusted that the ratio $\frac{R_1}{R_2}$ satisfies equation (ii) in the cited article.

The absolute magnitudes of these resistances depend on the electromotive force of the battery B_3 and the total resistance of the circuit 1, 2, 3, B_3 , 1 in Fig. 10. The effective sensitiveness of the method, and hence the accuracy attainable in adjusting the contacts 2 and 3 for the condition of balance, depends on the above

factors together with the resistance and intrinsic sensitiveness of the galvanometer.

Since R_1 and R_2 are adjusted in the same way and under the same conditions, the effective sensitiveness of the method is the same for both. Consequently only one of them will be considered in the present discussion, but the results obtained will apply with equal rigor to either. The essential parts of the apparatus and connections are illustrated in Fig. 12, which is the same as Fig. 10 with the battery B_2 and its connections omitted.

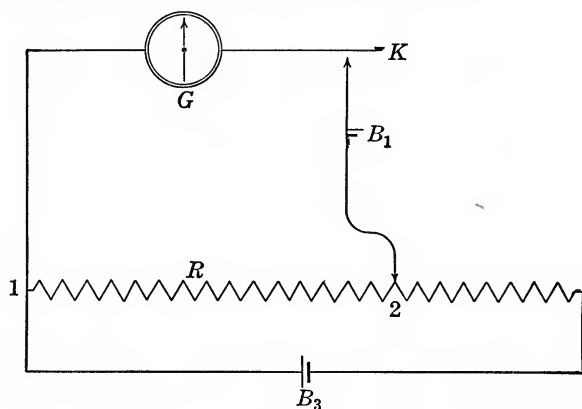

FIG. 12.

- Let
- V = e.m.f. of battery B_1 ,
 - E = e.m.f. of battery B_3 ,
 - R = resistance between 1 and 2,
 - W = total resistance of the circuit 1, 2, B_3 , 1,
 - G = total resistance of the branch 1, G , B_1 , 2,
 - I = current through B_3 ,
 - r = current through R ,
 - g = current through B_1 and G .

When the contact 2 is adjusted to the balance position

$$g = 0, \quad r = I, \quad \text{and} \quad I = \frac{E}{W} = \frac{V}{R}.$$

Consequently

$$V = E \frac{R}{W}. \quad (\text{xvii})$$

This is the fundamental equation of the potentiometer and must be fulfilled in every case of balance. Consequently E must be

chosen larger than V because R is a part of the resistance in the circuit 1, 2, B_3 , 1, and hence is always less than W . Equation (xvii) may then be satisfied by a suitable adjustment of R .

By applying Kirchoff's laws to the circuits 1, G , B_1 , 2, 1, and 1, 2, B_3 , 1, when the contact 2 is not in the balance position, we have

$$Rr - Gg = V,$$

and

$$Rr + (W - R)I = E.$$

But

$$r = I - g.$$

Hence

$$RI - (R + G)g = V,$$

and

$$WI - Rg = E.$$

Eliminating I and solving for g we find

$$g = \frac{WV - RE}{R^2 - WR - WG}. \quad (\text{xviii})$$

If D is the galvanometer deflection corresponding to the current g and K is the constant of the instrument

$$g = KD.$$

Most galvanometers are, or can be, provided with interchangeable coils. The winding space in such coils is usually constant, but the number of windings, and hence the resistance, is variable. Under these conditions the resistance of the galvanometer will be approximately proportional to the square of the number of turns of wire in the coils used. For the purpose of the present discussion, this resistance may be assumed to be equal to G since the resistance of the battery and connecting wires in branch 1, G , B_1 , 2, can usually be made very small in comparison with that of the galvanometer. The constant K is inversely proportional to the number of windings in the coils used. Consequently, as a sufficiently close approximation for our present purpose, we have

$$K = \frac{T}{\sqrt{G}},$$

where T is a constant determined by the dimensions of the coils, the moment of the directive couple, and various other factors depending on the type of galvanometer adopted. Hence, for any given instrument,

$$D = \frac{\sqrt{G}}{T} g. \quad (\text{xix})$$

The quantity $\frac{\sqrt{G}}{T}$ is the intrinsic sensitiveness of the galvanometer. It is equal to the deflection that would be produced by unit current if the instrument followed the same law for all values of g .

By equation (xix) and (xviii)

$$D = \frac{\sqrt{G}}{T} \cdot \frac{WV - RE}{R^2 - WR - WG}.$$

The variation in D due to a change dR in R is

$$\frac{\partial D}{\partial R} dR = -\frac{\sqrt{G}}{T} \cdot \frac{E(R^2 - WR - WG) + (WV - RE)(2R - W)}{(R^2 - WR - WG)^2} dR. \quad (xx)$$

When the potentiometer is adjusted for a balance, D is equal to zero and WV is equal to RE by equation (xvii). Hence, if δ is the galvanometer deflection produced when the resistance R is changed from the balancing value by an amount dR , equation (xx) may be put in the form

$$\delta = \frac{1}{T} \cdot \frac{V \sqrt{G}}{R^2 \left(1 - \frac{V}{E}\right) + RG} dR.$$

The fractional change in R corresponding to the total change dR is

$$P_r = \frac{dR}{R}.$$

Consequently

$$\delta = \frac{1}{T} \cdot \frac{V \sqrt{G}}{R \left(1 - \frac{V}{E}\right) + G} \cdot P_r \quad (xxi)$$

is the galvanometer deflection corresponding to a fractional error P_r in the adjustment of R for balance. The coefficient of P_r in equation (xxi) is the effective sensitiveness of the method under the given conditions. If this quantity is represented by S , equation (xxi) becomes

$$\delta = SP_r,$$

and

$$S = \frac{1}{T} \cdot \frac{V \sqrt{G}}{R \left(1 - \frac{V}{E}\right) + G} \quad (xxii)$$

All of the quantities appearing in the right-hand member of this equation may be considered as independent variables since equation (xvii) can always be satisfied, and hence the potentiometer

can be balanced, when R , V , and E have any assigned values, if the resistance W is suitably chosen.

If δ' is the smallest galvanometer deflection that can be definitely recognized with the available means of observation, the fractional error P_r' of a single observation on R should not be greater than $\frac{\delta'}{S}$. Since the precision attainable in adjusting the potentiometer for balance is inversely proportional to P_r' , it is directly proportional to the effective sensitiveness S . By choosing suitable magnitudes for the variables T , G , R , and E , it is usually possible to adjust the value of S , and hence also of P_r' , to meet the requirements of any problem.

From equation (xxii) it is evident that S will increase in magnitude continuously as the quantities T , R , and E decrease and that it does not pass through a maximum value. The practicable increase in S is limited by the following considerations: E must be greater than V , for the reason pointed out above, and its variation is limited by the nature of available batteries. Since E must remain constant while the potentiometer is being balanced alternately against V and the electromotive force of a standard cell, as explained in article eighty-one, the battery B_3 must be capable of generating a constant electromotive force during a considerable period of time. In practice storage cells are commonly used for this purpose and E may be varied by steps of about two volts by connecting the required number of cells in series. Obviously E should be made as nearly equal to V as local conditions permit.

When the potentiometer is balanced

$$\frac{V}{R} = \frac{E}{W} = I.$$

If R is reduced for the purpose of increasing the effective sensitiveness, W must also be reduced in like ratio, and, consequently, the current I through the instrument will be increased. The practical limit to this adjustment is reached when the heating effect of the current becomes sufficient to cause an appreciable change in the resistances R and W . With ordinary resistance boxes this limit is reached when I is equal to a few thousandths of an ampere. Consequently, if E is about two volts, R should not be made much less than one thousand ohms. Resistance coils made expressly for use in a potentiometer can be designed to carry a much larger

current so that R may be made less than one hundred ohms without introducing serious errors due to the heating effect of the current.

The constant T depends on the type and design of the galvanometer. In the suspended magnet type it can be varied somewhat by changing the strength of the external magnetic field, and in the D'Arsonval type the same result may be attained by changing the suspending wires of the movable coil. The effects of the vibrations of the building in which the instrument is located and of accidental changes in the external magnetic field become much more troublesome as T is decreased, i.e., as the intrinsic sensitiveness is increased. Consequently the practical limit to the reduction of T is reached when the above effects become sufficient to render the observation of small values of δ uncertain. This limit will depend largely on the location of the instrument and the care that is taken in mounting it. Sometimes a considerable reduction in T can be effected by selecting a type of galvanometer suited to the local conditions.

If the quantities T , R , V , and E are kept constant, S passes through a maximum value when G satisfies the condition

$$\frac{\partial S}{\partial G} = 0.$$

It can be easily proved by direct differentiation that this is the case when

$$G = R \left(1 - \frac{E}{V} \right). \quad (\text{xxiii})$$

Hence, after suitable values of the other variables have been determined as outlined above, the best magnitude for G is given by equation (xxiii). Generally this condition cannot be exactly fulfilled in practice unless a galvanometer coil is specially wound for the purpose; but, when several interchangeable coils are available, the one should be chosen that most nearly fulfills the condition. In some galvanometers T and G cannot be varied independently, and in such cases suitable values can be determined only by trial.

Since the ease and rapidity with which the observations can be made increase with T , it is usually advisable to adjust the other variables to give the greatest practicable value to the second factor in S , and then adjust T so that the effective sensitiveness

will be just sufficient to give the required precision in the determination of R .

As an illustration consider the numerical data given in article eighty-one. It was proved that the specified precision requirements cannot be satisfied unless R is determined within a fractional precision measure equal to ± 0.00063 . Allowing one-half of this to errors of calibration we have left for the allowable error in adjusting the potentiometer

$$P_r' = 0.00031.$$

If a single storage cell is used at B_3 , E is approximately two volts, and, with ordinary resistance boxes, R should be about one thousand ohms, for the reason pointed out above. This condition is fulfilled by the cited data; and, for our present purpose, it will be sufficiently exact to take V equal to one volt. Hence, by equation (xxiii), the most advantageous magnitude for G is about five hundred ohms; and, by equation (xxii), the largest practicable value for the second factor in S is

$$ST = \frac{V \sqrt{G}}{R \left(1 - \frac{V}{E}\right) + G} = 0.0224.$$

With a mirror galvanometer of the D'Arsonval type, read by telescope and scale, a deflection of one-half a millimeter can be easily detected. Consequently, if we express the galvanometer constant K in terms of amperes per centimeter deflection, we must take δ' equal to 0.05 centimeter; and, in order to fulfill the specified precision requirements, the effective sensitiveness must satisfy the condition

$$S = \frac{\delta'}{P_r'} = \frac{0.05}{0.00031} = 161.$$

Combining this result with the above maximum value of ST we find that the intrinsic sensitiveness must be such that

$$T = \frac{0.0224}{161} = 1.4 \times 10^{-4}.$$

Hence the galvanometer should be so constructed and adjusted that

$$G = 500 \text{ ohms,}$$

and

$$K = \frac{T}{\sqrt{G}} = 6.2 \times 10^{-6} \text{ amperes per centimeter deflection.}$$

D'Arsonval galvanometers that satisfy the above specifications can be very easily obtained and are much less expensive than more sensitive instruments. They are so nearly dead-beat and free from the effects of vibration that the adjustment of the potentiometer for balance can be easily and rapidly carried out with the necessary precision. Hence the use of such an instrument reduces the expense of the measurements without increasing the errors of observation beyond the specified limit.

CHAPTER XIII.

RESEARCH.

87. Fundamental Principles. — The word research, as used by men of science, signifies a detailed study of some natural phenomenon for the purpose of determining the relation between the variables involved or a comparative study of different phenomena for the purpose of classification. The mere execution of measurements, however precise they may be, is not research. On the other hand, the development of suitable methods of measurement and instruments for any specific purpose, the estimation of unavoidable errors, and the determination of the attainable limit of precision frequently demand rigorous and far-reaching research. As an illustration, it is sufficient to cite Michelson's determination of the length of the meter in terms of the wave length of light. A repetition of this measurement by exactly the same method and with the same instruments would involve no research, but the original development of the method and apparatus was the result of careful researches extending over many years.

The first and most essential prerequisite for research in any field is an idea. The importance of research, as a factor in the advancement of science, is directly proportional to the fecundity of the underlying ideas.

A detailed discussion of the nature of ideas and of the conditions necessary for their occurrence and development would lead us too far into the field of psychology. They arise more or less vividly in the mind in response to various and often apparently trivial circumstances. Their inception is sometimes due to a flash of intuition during a period of repose when the mind is free to respond to feeble stimuli from the subconscious. Their development and execution generally demand vigorous and sustained mental effort. Probably they arise most frequently in response to suggestion or as the result of careful, though tentative, observations.

A large majority of our ideas have been received, in more or less fully developed form, through the spoken or written discourse of their authors or expositors. Such ideas are the common

heritage of mankind, and it is one of the functions of research to correct and amplify them. On the other hand, original ideas, that may serve as a basis for effective research, frequently arise from suggestions received during the study of generally accepted notions or during the progress of other and sometimes quite different investigations.

The originality and productiveness of our ideas are determined by our previous mental training, by our habits of thought and action, and by inherited tendencies. Without these attributes, an idea has very little influence on the advancement of science. Important researches may be, and sometimes are, carried out by investigators who did not originate the underlying ideas. But, however these ideas may have originated, they must be so thoroughly assimilated by the investigator that they supply the stimulus and driving power necessary to overcome the obstacles that inevitably arise during the prosecution of the work. The driving power of an idea is due to the mental state that it produces in the investigator whereby he is unable to rest content until the idea has been thoroughly tested in all its bearings and definitely proved to be true or false. It acts by sustaining an effective concentration of the mental and physical faculties that quickens his ingenuity, broadens his insight, and increases his dexterity.

In order to become effective, an idea must furnish the incentive for research, direct the development of suitable methods of procedure, and guide the interpretation of results. But it must never be dogmatically applied to warp the facts of observation into conformity with itself. The mind of the investigator must be as ready to receive and give due weight to evidence against his ideas as to that in their favor. The ultimate truth regarding phenomena and their relations should be sought regardless of the collapse of generally accepted or preconceived notions. From this point of view, research is the process by which ideas are tested in regard to their validity.

88. General Methods of Physical Research. — Researches that pertain to the physical sciences may be roughly classified in two groups: one comprising determinations of the so-called physical constants such as the atomic weights of the elements, the velocity of light, the constant of gravitation, etc.; the other containing investigations of physical relations such as that which connects the mass, volume, pressure, and temperature of a gas.

The researches in the first group ultimately reduce to a careful execution of direct or indirect measurements and a determination of the precision of the results obtained. The general principles that should be followed in this part of the work have been sufficiently discussed in preceding chapters. Their application to practical problems must be left to the ingenuity and insight of the investigator. Some men, with large experience, make such applications almost intuitively. But most of us must depend on a more or less detailed study of the relative capabilities of available methods to guide us in the prosecution of investigations and in the discussion of results.

In general, physical constants do not maintain exactly the same numerical value under all circumstances, but vary somewhat with changes in surrounding conditions or with lapse of time. Thus the velocity of light is different in different media and in dispersive media it is a function of the frequency of the vibrations on which it depends. Consequently the determination of such constants should be accompanied by a thorough study of all of the factors that are likely to affect the values obtained and an exact specification of the conditions under which the measurements are made. Such a study frequently involves extensive investigations of the phenomena on which the constants depend and it should be carried out by very much the same methods that apply to the determination of physical relations in general. On the other hand, the exact expression of a physical relation generally involves one or more constants that must be determined by direct or indirect measurements. Hence there is no sharp line of division between the first and second groups specified above, many researches belonging partly to one group and partly to the other.

The occurrence of any phenomenon is usually the result of the coexistence of a number of more or less independent antecedents. Its complete investigation requires an exact determination of the relative effect of each of the contributory causes and the development of the general relation by which their interaction is expressed. A determination of the nature and mode of action of all of the antecedents is the first step in this process. Since it is generally impossible to derive useful information by observing the combined action of a number of different causal factors, it becomes necessary to devise means by which the effects of the several factors can be controlled in such manner that they can be studied

separately. The success of researches of this type depends very largely on the effectiveness of such means of control and the accuracy with which departures from specified conditions can be determined.

Suppose that an idea has occurred to us that a certain phenomenon is due to the interaction of a number of different factors that we will represent by A, B, C, \dots, P . This idea may involve a more or less definite notion regarding the relative effects of the several factors or it may comprehend only a notion that they are connected by some functional relation. In either case we wish to submit our idea to the test of careful research and to determine the exact form of the functional relation if it exists.

The investigation is initiated by making a series of preliminary observations of the phenomenon corresponding to as many variations in the values of the several factors as can be easily effected. The nature of such observations and the precision with which they should be made depend so much on the character of the problem in hand that it would be impossible to give a useful general discussion of suitable methods of procedure. Sometimes roughly quantitative, or even qualitative, observations are sufficient. In other cases a considerable degree of precision is necessary before definite information can be obtained. In all cases the observations should be sufficiently extensive and exact to reveal the general nature and approximate relative magnitudes of the effects produced by each of the factors. They should also serve to detect the presence of factors not initially contemplated.

With the aid of the information derived from preliminary observations and from a study of such theoretical considerations as they may suggest, means are devised for exactly controlling the magnitude of each of the factors. Methods are then developed for the precise measurement of these magnitudes under the conditions imposed by the adopted means of control. This process often involves a preliminary trial of several different methods for the purpose of determining their relative availability and precision. The methods that are found to be most exact and convenient usually require some modification to adapt them to the requirements of a particular problem. Sometimes it becomes necessary to devise and test entirely new methods. During this part of the investigation the discussions of the precision of measurements given in the preceding chapters find constant applica-

tion and it is largely through them that the suitability of proposed methods is determined.

After definite methods of measurement and means of control have been adopted and perfected to the required degree of precision, the final measurements on the factors, A, B, C, \dots, P , are carried out under the conditions that are found to be most advantageous. Usually two of the factors, say A and B , are caused to vary through as large a range of values as conditions will permit while the other factors are maintained constant at definite observed values. At stated intervals the progress of the variation is arrested and corresponding values of A and B are measured while they are kept constant. From a sufficiently extended series of such observations it is usually possible to make an empirical determination of the form of the functional relation

$$A = f_1(B); \quad C, D, \dots, P, \text{ constant.} \quad (\text{i})$$

On the other hand, if the form of the function f_1 is given as a theoretical deduction from the idea underlying the investigation, the observations serve to test the exactness of the idea and determine the magnitudes of the constants involved in the given function. By allowing different factors to vary and making corresponding measurements, the relations

$$\left. \begin{aligned} A &= f_2(C); \quad B, D, \dots, P, \text{ constant,} \\ \cdot &\quad \cdot \quad \cdot \quad \cdot \quad \cdot \quad \cdot \quad \cdot \quad \cdot \\ A &= f_n(P); \quad B, C, D, \dots, \text{ constant,} \end{aligned} \right\} \quad (\text{ii})$$

may be empirically determined or verified. As many functions of this type as there are pairs of factors might be determined, but usually it is not necessary to establish more than one relation for each factor. Generally it is convenient to determine one of the factors as a function of each of the others as illustrated above; but it is not necessary to do so, and sometimes the determination of a different set of relations facilitates the investigation.

During the establishment of the relation between any two factors all of the others are supposed to remain rigorously constant. Frequently this condition cannot be exactly fulfilled with available means of control, but the variations thus introduced can usually be made so small that their effects can be treated as constant errors and removed with the aid of the relations afterwards found to exist between the factors concerned. For this

purpose frequent observations must be made on the factors that are supposed to remain constant during the measurement of the two principal variables. If the variations in these factors are not very small all of the relations determined by the principal measurements will be more or less in error and must be treated as first approximations. Usually such errors can be eliminated and the true relations established with sufficient precision, by a series of successive approximations. However, the weight of the final result increases very rapidly with the effectiveness of the means of control and it is always worth while to exercise the care necessary to make them adequate.

When the functions involved in equations (i) and (ii), or their equivalents in terms of other combinations of factors, have been determined with sufficient precision, they can usually be combined into a single relation, in the form

$$\text{or } \left. \begin{array}{l} A = F(B, C, D, \dots, P), \\ F(A, B, C, D, \dots, P) = 0, \end{array} \right\} \quad \text{(iii)}$$

which expresses the general course of the investigated phenomenon in response to variations of the factors within the limits of the observations. Such generalizations may be purely empirical or they may rest partly or entirely on theoretical deductions from well-established principles. In either case the test of their validity lies in the exactness with which they represent observed facts. While an exact empirical formula finds many useful applications in practical problems it should not be assumed to express the true physical nature of the phenomenon it represents. In fact our understanding of any phenomenon is but scanty until we can represent its course by a formula that gives explicit or implicit expression to the physical principles that underlie it. Consequently a research ought not to be considered complete until the investigated phenomenon has been classified and represented by a function that exhibits the physical relations among its factors.

It is scarcely necessary to point out that a complete research as outlined above is seldom carried out by one man and that the underlying ideas very rarely originate at the same time or in the same person. The preliminary relations in the form of equations (i) and (ii) are frequently inspired by independent ideas and worked out by different men. The exact determination of any

one of them constitutes a research that is complete so far as it goes. The establishment of the general relation that comprehends all of the others and the interpretation of its physical significance are generally the result of a process of gradual growth and modification to which many men have contributed.

89. Graphical Methods of Reduction. — After the necessary measurements have been completed and corrected for all known constant errors, the form of the functions appearing in equations (i) and (ii), or other equations of similar type, and the numerical value of the constants involved can sometimes be determined easily and effectively by graphical methods. Such methods are almost universally adopted for the discussion of preliminary observations and the determination of approximate values of the constants. In some cases they are the only methods by which the results of the measurements can be expressed. In some other cases the constants can be more exactly determined by an application of the method of least squares to be described later. Usually, however, the general form of the functions and approximate values of the constants must first be determined by graphical methods or otherwise.

Let x and y represent the simultaneous values of two variable factors corresponding to specified constant values of the other factors involved in the phenomenon under investigation. Suppose that x has been varied by successive nearly equal steps through as great a range as conditions permit and that the simultaneous values x and y have been measured after each of these steps while the factors that they represent were kept constant. If all other factors have remained constant throughout these operations, the above series of measurements on x and y may be applied at once to the determination of the form and constants of the functional relation

$$y = f(x). \tag{iv}$$

This expression is of the same type as equations (i) and (ii). Consequently the following discussion applies generally to all cases in which there are only two variable factors. If the supposedly constant factors are not strictly constant during the measurements, the observations on x and y will not give the true form of the function in (iv) until they have been corrected for the effects of the variations thus introduced.

As the first step in the graphical method of reduction, the observations on x and y are laid off as abscissæ and ordinates on accurately squared paper, and the points determined by corresponding coördinates are accurately located with a fine pointed needle. The visibility of these points is usually increased by drawing a small circle or other figure with its center exactly at the indicated point. The scale of the plot should be so chosen that the form of the curve determined by the located points is easily recognized by eye. In order to bring out the desired relation, it is frequently necessary to adopt a different scale for ordinates and abscissæ. Usually it is advantageous to choose such scales that the total variations of x and y will be represented by approximately equal spaces. Thus, if the total variation of y is numerically equal to about one-tenth of the corresponding variation of x , the y 's should be plotted to a scale approximately ten times as large as that adopted for the x 's. In all cases the adopted scales should be clearly indicated by suitable numbers placed at equal intervals along the vertical and horizontal axes. Letters or other abbreviations should be placed near the ends of the axes to indicate the quantities represented.

The points thus located usually lie very nearly on a uniform curve that represents the functional relation (iv). Consequently the problem in hand may be solved by determining the equation of this curve and the numerical value of the constants involved in it. Sometimes it is impossible or inadvisable to carry out such a determination in practice and in such cases the plotted curve is the only available means of representing the relation between the observed factors. In all cases the deviations of the located points from the uniform curve represent the residuals of the observations, and, consequently, indicate the precision of the measurements on x and y .

The simplest case, and one that frequently occurs in practice, is illustrated in Fig. 13. The plotted points lie very nearly on a straight line. Consequently the functional relation (iv) takes the linear form

$$y = Ax + B, \tag{v}$$

where A is the tangent of the angle α between the line and the positive direction of the x axis, and B is the intercept \overline{OP} on the y axis. For the determination of the numerical values of the

constants A and B , the line should be sharply drawn in such a position that the plotted points deviate from it about equally in opposite directions, i.e., the sum of the positive deviations should be made as nearly as possible equal to the sum of the negative deviations. If this has been carefully and accurately done, the constant B may be determined by a direct measurement of the intercept \overline{OP} in terms of the scale used in plotting the y 's.

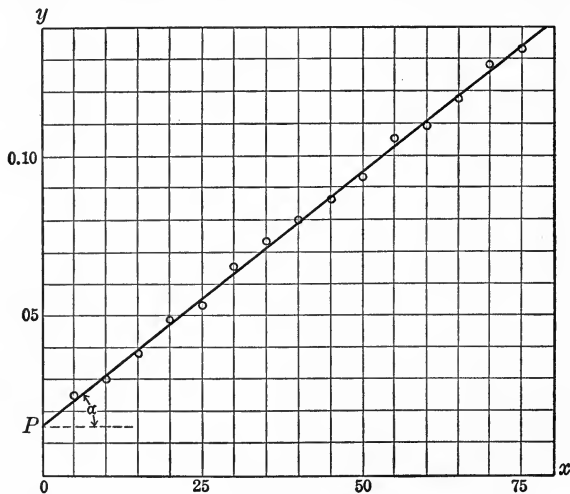

FIG. 13.

The constant A may be computed from measurements of the coördinates x_1 and y_1 of any point on the line, *not one of the plotted points*, by the relation

$$A = \frac{y_1 - B}{x_1}.$$

If the position of the line is such that the point P does not fall within the limits of the plotting sheet, the coördinates, x_1, y_1 and x_2, y_2 , of two points on the line are measured. Since they must satisfy equation (v),

$$y_1 = Ax_1 + B,$$

and

$$y_2 = Ax_2 + B.$$

Consequently

$$A = \frac{y_1 - y_2}{x_1 - x_2} \quad \text{and} \quad B = \frac{x_1 y_2 - x_2 y_1}{x_1 - x_2}.$$

The points selected for this purpose should be as widely separated as possible in order to reduce the effect of errors of plotting and

measurement. The accuracy of these determinations is likely to be greatest when the vertical and horizontal scales are so chosen that the line makes an angle of approximately forty-five degrees with the x axis. Space may sometimes be saved and the appearance of the plot improved by subtracting a constant quantity, nearly equal to B , from each of the y 's before they are plotted.

Many physical relations are not linear in form. Perhaps none of them are strictly linear when large ranges of variation are considered. Consequently the plotted points are more likely to lie nearly on some regular curve than on a straight line. In such cases the form of the functional relation (iv) is sometimes suggested by theoretical considerations, but frequently it must be determined by the method of trial and error or successive approximations. For this purpose the curve representing the observations is compared with a number of curves representing known equations. The equation of the curve that comes nearest to the desired form is modified by altering the numerical values of its constants until it represents the given measurements within the accidental errors of observation. Frequently several different equations and a number of modifications of the constants must be tried before satisfactory agreement is obtained.

When the desired relation does not contain more than two independent constants, it can sometimes be reduced to a linear relation between simple functions of x and y . Thus, the equation

$$y = Be^{-Ax}, \quad (vi)$$

represented by the curve in Fig. 14, is frequently met with in physical investigations. By inverting (vi) and introducing logarithms, we obtain the relation

$$\log_e y = \log_e B - Ax.$$

Hence if the logarithms of the y 's are laid off as ordinates against the corresponding x 's as abscissæ, the located points will lie very nearly on a straight line if the given observations satisfy the functional relation (vi). When this is the case, the constants A and $\log_e B$ may be determined by the methods developed during the discussion of equation (v). If logarithms to the base ten are used the above equation becomes

$$\log_{10} y = \log_{10} B - \frac{A}{M} x,$$

where M is the modulus of the natural system of logarithms. In this case the plot gives the values of $\log_{10} B$ and $\frac{A}{M}$ from which the constants A and B can be easily computed. When the plotted points do not lie nearer to a straight line than to any other curve,

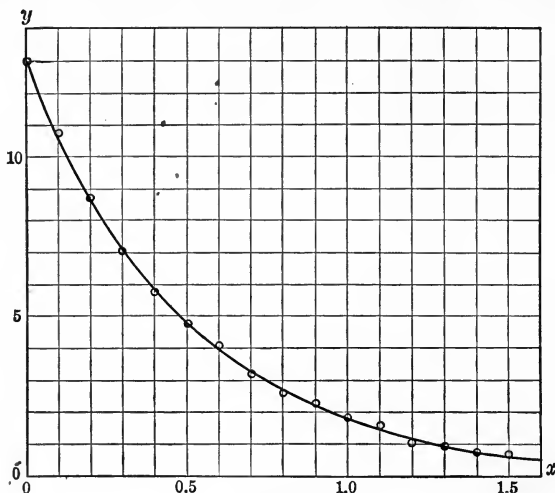

FIG. 14.

equation (vi) does not represent the functional relation between the observed factors and some other form must be tried. Many of the commonly occurring forms may be treated by the above method and the process is usually so simple that further illustration seems unnecessary.

The curve determined by plotting the x 's and y 's directly frequently exhibits points of discontinuity or sharp bends as at p and q in Fig. 15. Such irregularities are generally due to changes in the state of the material under investigation. The nature and causes of such changes are frequently determined, or at least suggested, by the location and character of such points. The different branches of the curve may correspond to entirely different equations or to equations in the same form but with different constants. In either case the equation of each branch must be determined separately.

The accuracy attainable by graphical methods depends very largely on the skill of the draughtsman in choosing suitable scales and executing the necessary operations. In many cases the errors

due to the plot are less than the errors of observation and it would be useless to adopt a more precise method of reduction. When the means of control are so well devised and effective that the constant errors left in the measurements are less than the errors of plotting it is probably worth while to make the reductions by the method of least squares, as explained in the following article.

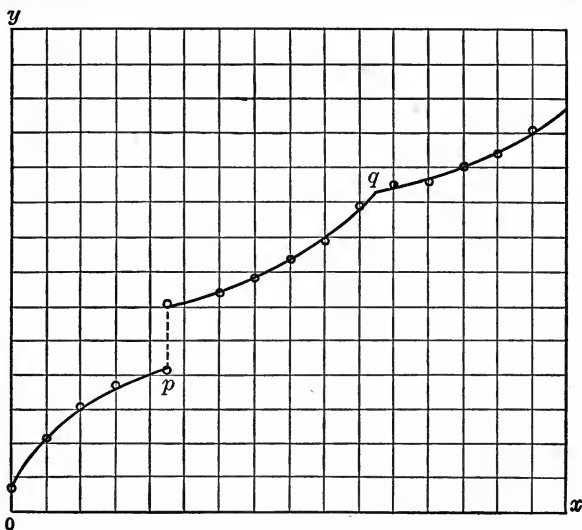

FIG. 15.

90. **Application of the Method of Least Squares.** — In the case of linear relations, expressible in the form of equation (v), the best values of the constants A and B can be very easily determined by applying the method of least squares in the manner explained in article fifty-one. However, as pointed out in the preceding article, very few physical relations are strictly linear when large variations of the involved factors are considered. Consequently a straight line, corresponding to constants determined as above, usually represents only a small part of the course of the investigated phenomenon. Such a line is generally a short chord of the curve that represents the true relation and consequently its direction depends on the particular range covered by the observations from which it is derived.

When the measurements are extended over a sufficiently wide range, the points plotted from them usually deviate from a straight line in an approximately regular manner, as illustrated in Fig. 16,

and lie very near to a continuous curve of slight curvature. Measurements of this type can always be represented empirically by a power series in the form

$$y = A + Bx + Cx^2 + \dots, \quad (\text{vii})$$

the number of terms and the signs of the constants depending on the magnitude and sign of the curvature to be represented.

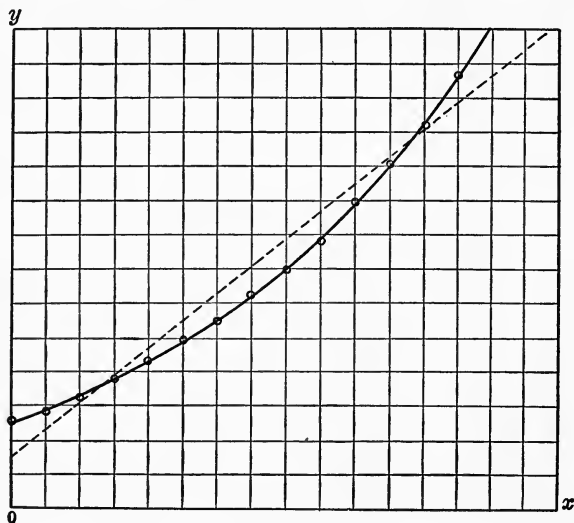

FIG. 16.

Since equation (vii) is linear with respect to the constants A , B , C , etc., they might be computed directly from the observations on x and y by the method of least squares. Usually, however, the computations can be simplified by introducing approximate values of the constants A and B . Thus, let A' and B' represent two numerical quantities so chosen that the line

$$y' = A' + B'x$$

passes in the same general direction as the plotted points, in the manner illustrated by the dotted line in Fig. 16. The difference between y and y' can be put in the form

$$y - y' = (A - A') + M_1(B - B') \frac{x}{M_1} + M_2C \frac{x^2}{M_2} + \dots, \quad (\text{viii})$$

where M_1 , M_2 , etc., represent numerical constants so chosen that the quantities $y - y'$, $\frac{x}{M_1}$, $\frac{x^2}{M_2}$, etc., are nearly of the same order

of magnitude. For the sake of convenience let

$$\left. \begin{array}{l} y - y' = s; \quad \frac{x}{M_1} = b; \quad \frac{x^2}{M_2} = c; \dots, \\ \text{and} \quad A - A' = x_1; \quad M_1(B - B') = x_2; \quad M_2C = x_3; \dots \end{array} \right\} \text{(ix)}$$

The quantities s, b, c , etc., may be derived from the observations, with the aid of the assumed constants A', B', M_1, M_2 , etc.; and x_1, x_2, x_3 , etc., are the unknowns to be computed by the method of least squares. After the above substitutions, equation (viii) takes the simple form

$$x_1 + bx_2 + cx_3 + \dots = s,$$

which is identical with that of the observation equations (53), article forty-nine. As many equations of this type may be formed as there are pairs of corresponding measurements on x and y .

The normal equations (56) may be derived from the observation equations thus established, by the methods explained in articles fifty and fifty-three. Their final solution for the unknowns x_1, x_2, x_3 , etc., may be effected by Gauss's method, developed in article fifty-four and illustrated in article fifty-five, or by any other convenient method. The corresponding numerical values of the constants A, B, C , etc., may then be computed by equations (ix). These values, when substituted in (vii), give the required empirical relation between x and y .

If a sufficient number of terms have been included in equation (vii), the relation thus established will represent the given measurements within the accidental errors of observation. The residuals, computed by equations (54), article forty-nine, and arranged in the order of increasing values of y , should show approximately as many sign changes as sign follows. When this is not the case the observed y 's deviate systematically from the values given by equation (vii) for corresponding x 's. In such cases the number of terms employed is not sufficient for the exact representation of the observed phenomenon, and a new relation in the same general form as the one already tested but containing more independent constants should be determined. This process must be repeated until such a relation is established that systematically varying differences between observed and computed y 's no longer occur.

The observation equations used as a basis for the numerical illustration given in article fifty-five were derived from the follow-

ing observations on the thermal expansion of petroleum by equations (viii) and (ix), taking

$$A' = 1000; \quad B' = 1; \quad M_1 = 10; \quad \text{and} \quad M_2 = 1000.$$

x temperature	y volume
degrees	cc.
0	1000.24
20	1018.82
40	1038.47
60	1059.31
80	1081.20
100	1104.27

The computations carried out in the cited article resulted as follows:

$$x_1 = 0.245; \quad x_2 = -1.0003; \quad x_3 = 1.4022.$$

Hence, by equations (ix)

$$A = 1000.245; \quad B = 0.89997; \quad C = 0.0014022,$$

and the functional relation (vii) becomes

$$y = 1000.245 + 0.89997 \cdot x + 0.0014022 \cdot x^2.$$

The residuals corresponding to this relation, computed and tabulated in article fifty-five, show five sign changes and no sign follows. Such a distribution of signs sometimes indicates that the observed factors deviate periodically from the assumed functional relation. In the present case, however, the number of observations is so small that the apparent indications of the residuals are probably fortuitous. Consequently it would not be worth while to repeat the computations with a larger number of terms unless it could be shown by independent means that the accidental errors of the observations are less than the residuals corresponding to the above relation.

Any continuous relation between two variables can usually be represented empirically by an expression in the form of equation (vii). However, it frequently happens that the physical significance of the investigated phenomenon is not suggested by such an expression but is represented explicitly by a function that is not linear with respect to either the variable factors or the constants involved. Such functions usually contain more than two independent constants and sometimes include more than two variable factors. They may be expressed by the general equation

$$y = F(A, B, C, \dots, x, z, \dots), \quad (154)$$

where A, B, C , etc., represent constants to be determined and y, x, z , etc., represent corresponding values of observed factors.

Sometimes the form of the function F is given by theoretical considerations, but more frequently it must be determined, together with the numerical values of the constants, by the method of successive approximations. In the latter case a definite form, suggested by the graphical representation of the observations or by analogy with similar phenomena, is assumed tentatively as a first approximation. Then, by substituting a number of different corresponding observations on y, x, z , etc., in (154), as many independent equations as there are constants in the assumed function are established. The simultaneous solution of these equations gives first approximations to the values of the constants A, B, C , etc. Sometimes the solution cannot be effected directly by means of the ordinary algebraic methods, but it can usually be accomplished with sufficient accuracy either by trial and error or by some other method of approximation.

Let A', B', C' , etc., represent approximate values of the constants and let $\delta_1, \delta_2, \delta_3$, etc., represent their respective deviations from the true values. Then

$$A = A' + \delta_1; \quad B = B' + \delta_2; \quad C = C' + \delta_3, \text{ etc.}, \quad (155)$$

and (154) may be put in the form

$$y = F \{ (A' + \delta_1), (B' + \delta_2), (C' + \delta_3), \dots, x, z, \dots \} \quad (x)$$

If the δ 's are so small that their squares and higher powers may be neglected, expansion by Taylor's Theorem gives

$$y = F(A', B', C', \dots, x, z, \dots) + \frac{\partial F}{\partial A} \delta_1 + \frac{\partial F}{\partial B} \delta_2 + \frac{\partial F}{\partial C} \delta_3 + \dots$$

By putting

$$\left. \begin{aligned} y - F(A', B', C', \dots, x, z, \dots) &= s; \\ \frac{\partial F}{\partial A} &= a; \quad \frac{\partial F}{\partial B} = b; \quad \frac{\partial F}{\partial C} = c, \text{ etc.}, \end{aligned} \right\} \quad (156)$$

and transposing, equation (xi) becomes

$$a\delta_1 + b\delta_2 + c\delta_3 + \dots = s. \quad (157)$$

As many independent equations of this type as there are sets of corresponding observations on y, x, z , etc., can be formed. The absolute term s and the coefficients a, b, c , etc., in each equation are computed from a single set of observations by the relations

(156) with the aid of the approximate values A', B', C' , etc. Since the resulting equations are in the same form as the observation equations (53), the normal equations (56) may be found and solved by the methods described in Chapter VII. The values of $\delta_1, \delta_2, \delta_3$, etc., thus obtained, when substituted in (155), give second approximations to the values of the constants A, B, C , etc.

The accuracy of the second approximations will depend on the assumed form of the function F and on the magnitude of the corrections $\delta_1, \delta_2, \delta_3$, etc. If these corrections are not small, the conditions underlying equation (xi) are not fulfilled and the results obtained by the above process may deviate widely from the correct values of the constants; but, except in extreme cases, they are more accurate than the first approximations A', B', C' , etc. Let A'', B'', C'' , etc., represent the second approximations. The corresponding residuals, r_1, r_2, \dots, r_n , may be computed by substituting different sets of corresponding observations on y, x, z , etc., successively in the equation

$$F(A'', B'', C'', \dots, x, z, \dots) - y = r, \quad (\text{xii})$$

where the function F has the same form that was used in computing the corrections $\delta_1, \delta_2, \delta_3$, etc. If these residuals are of the same order of magnitude as the accidental errors of the observations and distributed in accordance with the laws of such errors, the functional relation

$$y = F(A'', B'', C'', \dots, x, z, \dots) \quad (158)$$

is the most probable result that can be derived from the given observations.

Frequently the residuals corresponding to the second approximations do not satisfy the above conditions. This may be due to the inadequacy of the assumed form of the function F , to insufficient precision of the approximations A'', B'', C'' , etc., or to both of these causes.

If the form of the function is faulty, the residuals usually show systematic and easily recognizable deviations from the distribution characteristic of accidental errors. Generally the number of sign follows greatly exceeds the number of sign changes, when the residuals are arranged in the order of increasing y 's, and opposite signs do not occur with nearly the same frequency. Sometimes the nature of the fault can be determined by inspecting the order

of sequence of the residuals or by comparing the graph corresponding to equation (158) with the plotted observations. After the form of the function F has been rectified, by the above means or otherwise, the computations must be repeated from the beginning and the new form must be tested in the same manner as its predecessor. This process should be continued until the residuals corresponding to the second approximations give no evidence that the form of the function on which they depend is faulty.

When the residuals, computed by equation (xii), do not suggest that the assumed form of the function F is inadequate, but are large in comparison with the probable errors of the observations, the second approximations are not sufficiently exact. In such cases new equations in the form of (157) are derived by using A'' , B'' , C'' , etc., in place of A' , B' , C' , etc., in equations (156). The solution of the equations thus formed, by the method of least squares, gives the corrections δ_1' , δ_2' , δ_3' , etc., that must be applied to A'' , B'' , C'' , etc., in order to obtain the third approximations

$$A''' = A'' + \delta_1'; \quad B''' = B'' + \delta_2'; \quad C''' = C'' + \delta_3'; \text{ etc.}$$

These operations must be repeated until the residuals corresponding to the last approximations are of the same order of magnitude as the accidental errors of the observations.

Although an algebraic expression, that represents any given series of observations with sufficient precision, can usually be derived by the foregoing methods, such a procedure is by no means advisable in all cases. In many investigations, a graphical representation of the results leads to quite as definite and trustworthy conclusions as the more tedious mathematical process. Consequently the latter method is usually adopted only when the former is inapplicable or fails to utilize the full precision of the observations. In all cases the choice of suitable methods and the establishment of rational conclusions is a matter of judgment and experience.

91. Publication.—Research does not become effective as a factor in the advancement of science until its results have been published, or otherwise reported, in intelligible and widely accessible form. It is the duty as well as the privilege of the investigator to make such report as soon as he has arrived at definite conclusions. But nothing could be more inadvisable or untimely than the premature publication of observations that have not been thoroughly discussed and correlated with fundamental principles.

Until an investigation has progressed to such a point that it makes some definite addition to existing ideas, or gives some important physical constant with increased precision, its publication is likely to retard rather than stimulate the progress of science. On the other hand, free discussion of methods and preliminary results is an effective molder of ideas.

The form of a published report is scarcely less important than the substance. The significance of the most brilliant ideas may be entirely masked by faulty or inadequate expression. Hence the investigator should strive to develop a lucid and concise style that will present his ideas and the observations that support them in logical sequence. Above all things he should remember that the value of a scientific communication is measured by the importance of the underlying ideas, not by its length.

The author's point of view, the problem he proposes to solve, and the ideas that have guided his work should be clearly defined. Theoretical considerations should be rigorously developed in so far as they have direct bearing on the work in hand. But general discussions that can be found in well-known treatises or in easily accessible journals should be given by reference, and the formulæ derived therein assumed without further proof whenever their rigor is not questioned. However, the author should always explain his own interpretation of adopted formulæ and point out their significance with respect to his observations. Due weight and credit should be given to the ideas and results of other workers in the same or closely related fields, but lengthy descriptions of their methods and apparatus should be avoided. Explicit reference to original sources is usually sufficient.

The methods and apparatus actually used in making the reported observations should be concisely described, with the aid of schematic diagrams whenever possible. Well-known methods and instruments should be described only in so far as they have been modified to fulfill special purposes. Detailed discussion of all of the methods and instruments that have been found to be inadequate are generally superfluous, but the difficulties that have been overcome should be briefly pointed out and explained. The precautions adopted to avoid constant errors should be explicitly stated and the processes by which unavoidable errors of this type have been removed from the measurements should be clearly described. The effects likely to arise from such errors should be

considered briefly and the magnitude of applied corrections should be stated.

Observations and the results derived from them should be reported in such form that their significance is readily intelligible and their precision easily ascertainable. In many cases graphical methods of representation are the most suitable provided the points determined by the observations are accurately located and marked. The reproduction of a large mass of numerical data is thus avoided without detracting from the comprehensiveness of the report. When such methods do not exhibit the full precision of the observations or when they are inapplicable on account of the nature of the problem in hand, the original data should be reproduced with sufficient fullness to substantiate the conclusions drawn from them. In such cases the significance of the observations and derived results can generally be most convincingly brought out by a suitable tabulation of numerical data. An estimate of the precision attained should be made whenever the results of the investigation can be expressed numerically.

Final conclusions should be logically drawn, explicitly stated, and rigorously developed in their theoretical bearings. They express a culmination of the author's ideas relative to the investigated phenomena and invite criticism of their exactness and rationality. Unless they are amply substantiated by the observations and theoretical considerations brought forward in their support, and constitute a real addition to scientific knowledge, they are likely to receive scant recognition.

TABLES.

The following tables contain formulæ and numerical data that will be found useful to the student in applying the principles developed in the preceding chapters. The four figure numerical tables are amply sufficient for the computation of errors, but more extensive tables should be used in computing indirectly measured magnitudes whenever the precision of the observations warrants the use of more than four significant figures.

The references placed under some of the tables indicate the texts from which they were adapted.

TABLE I. — DIMENSIONS OF UNITS.

Units.	Dimensions.	
Fundamental.	Length, mass, time.	Length, force, time.
Length.....	[L]	[L]
Mass.....	[M]	[L ⁻¹ F T ²]
Time.....	[T]	[T]
Force.....	[LMT ⁻²]	[F]
Area.....	[L ²]	[L ²]
Volume.....	[L ³]	[L ³]
Density.....	[L ⁻³ M]	[L ⁻⁴ F T ²]
Angle.....	[LL ⁻¹]	[LL ⁻¹]
Velocity, linear.....	[LT ⁻¹]	[LT ⁻¹]
Velocity, angular.....	[T ⁻¹]	[T ⁻¹]
Acceleration, linear.....	[LT ⁻²]	[LT ⁻²]
Acceleration, angular.....	[T ⁻²]	[T ⁻²]
Momentum.....	[LMT ⁻¹]	[FT]
Moment of inertia.....	[L ² M]	[LFT ²]
Moment of momentum.....	[L ² MT ⁻¹]	[LFT]
Torque.....	[L ² MT ⁻²]	[LF]
Pressure.....	[L ⁻¹ MT ⁻²]	[L ⁻² F]
Energy, work.....	[L ² MT ⁻²]	[LF]
Power.....	[L ² MT ⁻³]	[LFT ⁻¹]

TABLE II. — CONVERSION FACTORS.

<i>Length Units.</i>		Logarithm.
1 centimeter (cm.)	= 0.393700 inch.....	1̄.5951654
“	= 0.0328083 foot.....	2̄.5159842
“	= 0.0109361 yard.....	2̄.0388629
1 meter (m.)	= 1000 millimeters.....	3.0000000
“	= 100 centimeters.....	2.0000000
“	= 10 decimeters.....	1.0000000
1 kilometer (km.)	= 1000 meters.....	3.0000000
“	= 0.621370 mile.....	1̄.7933503
“	= 3280.83 feet.....	3.5159842
1 inch (in.)	= 2.540005 centimeters.....	0.4048346
1 foot (ft.)	= 12 inches.....	1.0791812
“	= 30.4801 centimeters.....	1.4840158
1 yard (yd.)	= 36 inches.....	1.5563025
“	= 3 feet.....	0.4771213
“	= 91.4402 centimeters.....	1.9611371
1 mile (ml.)	= 5280 feet.....	3.7226339
“	= 1760 yards.....	3.2455127
“	= 1609.35 meters.....	3.2066497
“	= 0.868392 knot (U. S.).....	1̄.9387157
 <i>Mass Units.</i> 		
1 gram (g.)	= 1000 milligrams.....	3.0000000
“	= 100 centigrams.....	2.0000000
“	= 10 decigrams.....	1.0000000
“	= 0.0352740 ounce (av.).....	2̄.5474542
“	= 0.00220462 pound (av.).....	3̄.3433342
“	= 0.000068486 slug.....	5̄.8355997
1 kilogram (kg.)	= 1000 grams.....	3.0000000
1 ounce (oz.) (av.)	= 28.3495 grams.....	1.4525458
“	= 0.062500 pound (av.).....	2̄.7958800
“	= 0.0019415 slug.....	3̄.2881455
1 pound (lb.) (av.)	= 16 ounces (av.).....	1.2041200
“	= 453.5924277 grams.....	2.6566658
“	= 0.0310646 slug.....	2̄.4922655
1 slug (sg.)	= 32.191 pounds (av.).....	1.5077345
“	= 515.06 ounces (av.).....	2.7118545
“	= 14601.6 grams.....	4.1644003
1 short ton (tn.)	= 2000 pounds (av.).....	3.3010300
“	= 907.185 kilograms.....	2.9576958
“	= 62.129 slugs.....	1.7932955

TABLE II.—CONVERSION FACTORS (*Concluded*).

<i>Force Units.</i>		
The following gravitational units are expressed in terms of the earth's attraction at London where the acceleration due to gravity is 32.191 ft./sec. ² or 981.19 cm./sec. ²		
		Logarithm.
1 dyne	= 1.01917 milligram's wt.	0.0082469
“	= 0.00101917 gram's wt.	$\bar{3}$.0082469
“	= 2.2469×10^{-6} pound's wt.	$\bar{6}$.3515811
1 gram's wt.	= 981.19 dynes.	2.9917531
1 kilogram's wt.	= 1000 gram's wt.	3.0000000
“	= 98.119×10^4 dynes.	5.9917531
“	= 2.20462 pound's wt.	0.3433342
1 pound's wt.	= 0.45359 kilogram's wt.	$\bar{1}$.6566658
“	= 44.506×10^4 dynes.	5.6484189
1 pound's wt. (local)	= $g/32.191$ pound's wt. at London.	
	g = local acceleration due to gravity in ft./sec. ² .	
<i>Mean Solar Time Units.</i>		
1 second (s.)	= 0.016667 minute.	$\bar{2}$.2218487
“	= 0.00027778 hour.	$\bar{4}$.4436975
“	= 0.000011574 day.	$\bar{5}$.0634863
1 minute (m.)	= 60 seconds.	1.7781513
“	= 0.016667 hour.	$\bar{2}$.2218487
“	= 0.00069444 day.	$\bar{4}$.8416375
1 hour (h.)	= 3600 seconds.	3.5563025
“	= 60 minutes.	1.7781513
“	= 0.041667 day.	$\bar{2}$.6197888
1 day (d.)	= 86400 seconds.	4.9365137
“	= 1440 minutes.	3.1583625
“	= 24 hours.	1.3802112
1 mean solar unit	= 1.00273791 sidereal units.	0.0011874
<i>Angle Units.</i>		
1 circumference	= 360 degrees.	2.5563025
“	= 2π radians.	0.7981799
“	= 6.28319 radians.	0.7981799
1 degree (°)	= 0.017453 radian.	$\bar{2}$.2418774
“	= 60 minutes.	1.7781513
“	= 3600 seconds.	3.5563025
1 minute (')	= 2.9089×10^{-4} radians.	$\bar{4}$.4637261
“	= 0.016667 degree.	$\bar{2}$.2218487
“	= 60 seconds.	1.7781513
1 second (")	= 4.8481×10^{-6} radians.	$\bar{6}$.6855749
“	= 2.7778×10^{-4} degrees.	$\bar{4}$.4436975
“	= 0.01667 minute.	$\bar{2}$.2218487
1 radian	= 57.29578 degrees.	1.7581226
“	= 3437.7468 minutes.	3.5362739
“	= 206264.8 seconds.	5.3144251

TABLE III. — TRIGONOMETRICAL RELATIONS.

$$\begin{aligned} \sin \alpha &= \alpha - \frac{\alpha^3}{3!} + \frac{\alpha^5}{5!} - \dots (-1)^{n-1} \frac{\alpha^{2n-1}}{(2n-1)!} \\ &= \frac{1}{2i} (e^{i\alpha} - e^{-i\alpha}) \\ &= \sqrt{1 - \cos^2 \alpha} = \sqrt{\frac{1 - \cos 2\alpha}{2}} = \frac{1}{\operatorname{cosec} \alpha} \\ &= 2 \sin \frac{\alpha}{2} \cos \frac{\alpha}{2} = \frac{\cos \alpha}{\cot \alpha} = \frac{\tan \alpha}{\sec \alpha} \\ &= \frac{\tan \alpha}{\sqrt{1 + \tan^2 \alpha}} = \frac{1}{\sqrt{1 + \cot^2 \alpha}} = \cos \alpha \tan \alpha \\ &= \sin \beta \cos (\beta - \alpha) - \cos \beta \sin (\beta - \alpha) \\ &= \cos \beta \sin (\beta + \alpha) - \sin \beta \cos (\beta + \alpha). \end{aligned}$$

$$\sin \frac{1}{2} \alpha = \sqrt{\frac{1 - \cos \alpha}{2}}.$$

$$\sin 2\alpha = 2 \sin \alpha \cos \alpha = \frac{2 \tan \alpha}{1 + \tan^2 \alpha}.$$

$$\sin^2 \alpha = 1 - \cos^2 \alpha = -\frac{1}{2} (\cos 2\alpha - 1).$$

$$\sin (\alpha \pm \beta) = \sin \alpha \cos \beta \pm \cos \alpha \sin \beta.$$

$$\sin \alpha \pm \sin \beta = 2 \sin \frac{1}{2} (\alpha \pm \beta) \cos \frac{1}{2} (\alpha \mp \beta).$$

$$\sin^2 \alpha + \sin^2 \beta = 1 - \cos (\alpha + \beta) \cos (\alpha - \beta).$$

$$\sin^2 \alpha - \sin^2 \beta = \cos^2 \beta - \cos^2 \alpha = \sin (\alpha + \beta) \sin (\alpha - \beta).$$

$$\sqrt{1 + \sin \alpha} = \sin \frac{1}{2} \alpha + \cos \frac{1}{2} \alpha.$$

$$\sqrt{1 - \sin \alpha} = \pm (\sin \frac{1}{2} \alpha - \cos \frac{1}{2} \alpha).$$

$$\cos \alpha = 1 - \frac{\alpha^2}{2!} + \frac{\alpha^4}{4!} - \dots (-1)^n \frac{\alpha^{2n}}{2n!}$$

$$= \frac{1}{2} (e^{i\alpha} + e^{-i\alpha})$$

$$= \sqrt{1 - \sin^2 \alpha} = \sqrt{\frac{1 + \cos 2\alpha}{2}} = 2 \cos^2 \frac{1}{2} \alpha - 1$$

$$= 1 - 2 \sin^2 \frac{1}{2} \alpha = \cos^2 \frac{1}{2} \alpha - \sin^2 \frac{1}{2} \alpha$$

$$= \frac{1}{\sqrt{1 + \tan^2 \alpha}} = \frac{\cot \alpha}{\sqrt{1 + \cot^2 \alpha}} = \sin \alpha \cot \alpha$$

$$= \frac{\sin \alpha}{\tan \alpha} = \frac{\cot \alpha}{\operatorname{cosec} \alpha} = \frac{1}{\sec \alpha}$$

$$= \cos \beta \cos (\alpha + \beta) + \sin \beta \sin (\alpha + \beta)$$

$$= \cos \beta \cos (\beta - \alpha) + \sin \beta \sin (\beta - \alpha).$$

$$\cos \frac{1}{2} \alpha = \sqrt{\frac{1 + \cos \alpha}{2}}.$$

TABLE III.—TRIGONOMETRICAL RELATIONS (Continued).

$$\cos 2\alpha = 2\cos^2\alpha - 1 = 1 - 2\sin^2\alpha$$

$$= \cos^2\alpha - \sin^2\alpha = \frac{1 - \tan^2\alpha}{1 + \tan^2\alpha}.$$

$$\cos^2\alpha = 1 - \sin^2\alpha = \frac{1}{2}(\cos 2\alpha + 1).$$

$$\cos(\alpha \pm \beta) = \cos\alpha \cos\beta \mp \sin\alpha \sin\beta.$$

$$\cos\alpha + \cos\beta = 2\cos\frac{1}{2}(\alpha + \beta)\cos\frac{1}{2}(\alpha - \beta).$$

$$\cos\alpha - \cos\beta = -2\sin\frac{1}{2}(\alpha + \beta)\sin\frac{1}{2}(\alpha - \beta).$$

$$\cos^2\alpha + \cos^2\beta = 1 + \cos(\alpha + \beta)\cos(\alpha - \beta).$$

$$\cos^2\alpha - \cos^2\beta = \sin^2\beta - \sin^2\alpha = -\sin(\alpha + \beta)\sin(\alpha - \beta).$$

$$\cos^2\alpha - \sin^2\beta = \cos(\alpha + \beta)\cos(\alpha - \beta) = \cos^2\beta - \sin^2\alpha.$$

$$\sin\alpha + \cos\alpha = \sqrt{1 + \sin 2\alpha}.$$

$$\sin\alpha - \cos\alpha = \sqrt{1 - \sin 2\alpha}.$$

$$\sin^2\alpha + \cos^2\alpha = 1.$$

$$\sin^2\alpha - \cos^2\alpha = -\cos 2\alpha.$$

$$\tan\alpha = \alpha + \frac{1}{3}\alpha^3 + \frac{2}{15}\alpha^5 + \frac{17}{315}\alpha^7 + \dots \quad \pi > \alpha > -\pi$$

$$= \frac{1}{i} \frac{e^{i\alpha} - 1}{e^{i\alpha} + 1}$$

$$= \frac{\sin\alpha}{\cos\alpha} = \frac{\sin 2\alpha}{1 + \cos 2\alpha} = \frac{1 - \cos 2\alpha}{\sin 2\alpha}$$

$$= \sqrt{\frac{1 - \cos 2\alpha}{1 + \cos 2\alpha}} = \sqrt{\frac{1}{\cos^2\alpha} - 1} = \frac{\sin\alpha}{\sqrt{1 - \sin^2\alpha}}$$

$$= \frac{\sec\alpha}{\operatorname{cosec}\alpha} = \sqrt{\sec^2\alpha - 1} = \frac{1}{\sqrt{\operatorname{cosec}^2\alpha - 1}}.$$

$$= \frac{1}{\cot\alpha} = \cot\alpha - 2\cot 2\alpha$$

$$= \frac{\sin(\alpha + \beta) + \sin(\alpha - \beta)}{\cos(\alpha + \beta) + \cos(\alpha - \beta)} = \frac{\cos(\alpha - \beta) - \cos(\alpha + \beta)}{\sin(\alpha + \beta) - \sin(\alpha - \beta)}.$$

$$\tan 2\alpha = \frac{2\tan\alpha}{1 - \tan^2\alpha} = \frac{2\cot\alpha}{\cot^2\alpha - 1} = \frac{2}{\cot\alpha - \tan\alpha}.$$

$$\tan \frac{1}{2}\alpha = \frac{\tan\alpha}{1 + \sec\alpha} = \operatorname{cosec}\alpha - \cot\alpha.$$

$$\tan(\alpha \pm \beta) = \frac{\tan\alpha \pm \tan\beta}{1 \mp \tan\alpha \tan\beta} = \frac{\cos 2\beta - \cos 2\alpha}{\sin 2\beta \mp \sin 2\alpha}.$$

$$\tan\alpha \pm \tan\beta = \frac{\sin(\alpha \pm \beta)}{\cos\alpha \cos\beta}.$$

TABLE III. — TRIGONOMETRICAL RELATIONS (Concluded).

$$\begin{aligned} \cot \alpha &= \frac{1}{\alpha} - \frac{1}{3} \alpha - \frac{1}{45} \alpha^3 - \frac{2}{315} \alpha^5 - \dots \quad \pi > \alpha > -\pi \\ &= i \frac{e^{2i\alpha} + 1}{e^{2i\alpha} - 1} \\ &= \frac{\cos \alpha}{\sin \alpha} = \frac{\sin 2\alpha}{1 - \cos 2\alpha} = \frac{1 + \cos 2\alpha}{\sin 2\alpha} \\ &= \sqrt{\frac{1 + \cos 2\alpha}{1 - \cos 2\alpha}} = \frac{\cos \alpha}{\sqrt{1 - \cos^2 \alpha}} = \frac{\sqrt{1 - \sin^2 \alpha}}{\sin \alpha} \\ &= \frac{\operatorname{cosec} \alpha}{\sec \alpha} = \sqrt{\operatorname{cosec}^2 \alpha - 1} = \frac{1}{\sqrt{\sec^2 \alpha - 1}} \\ &= \frac{1}{\tan \alpha} = \tan \alpha + 2 \cot 2\alpha. \\ \cot 2\alpha &= \frac{1 - \tan^2 \alpha}{2 \tan \alpha} = \frac{\cot^2 \alpha - 1}{2 \cot \alpha} = \frac{\cot \alpha - \tan \alpha}{2}. \\ \cot \frac{1}{2} \alpha &= (1 + \sec \alpha) \cot \alpha = \frac{1}{\operatorname{cosec} \alpha - \cot \alpha}. \\ \cot(\alpha \pm \beta) &= \frac{1 \mp \tan \alpha \tan \beta}{\tan \alpha \pm \tan \beta} = \frac{\cot \alpha \cot \beta \mp 1}{\cot \beta \pm \cot \alpha}. \\ \cot \alpha \pm \cot \beta &= \frac{\sin(\beta \pm \alpha)}{\sin \alpha \sin \beta}. \end{aligned}$$

TABLE IV. — SERIES.

Taylor's Theorem.

$$\begin{aligned} f(x+h) &= f(x) + hf'(x) + \frac{h^2}{2!} f''(x) + \dots + \frac{h^n}{n!} f^{(n)}(x) + \dots \\ f(x+h, y+k, z+l) &= u + \left(h \frac{\partial}{\partial x} + k \frac{\partial}{\partial y} + l \frac{\partial}{\partial z} \right) u + \frac{1}{2!} \left(h \frac{\partial}{\partial x} + k \frac{\partial}{\partial y} + l \frac{\partial}{\partial z} \right)^2 u \\ &+ \dots + \frac{1}{n!} \left(h \frac{\partial}{\partial x} + k \frac{\partial}{\partial y} + l \frac{\partial}{\partial z} \right)^n u + \dots \end{aligned}$$

where

$$u = f(x, y, z).$$

Maclaurin's Series.

$$f(x) = f(0) + \frac{x}{1} f'(0) + \frac{x^2}{2!} f''(0) + \dots + \frac{x^n}{n!} f^{(n)}(0).$$

TABLE IV.—SERIES (Concluded).

Binomial Theorem.

$$(x + y)^m = x^m + \frac{m}{1} x^{m-1} y + \frac{m(m-1)}{2!} x^{m-2} y^2 + \dots \\ \dots + \frac{m(m-1) \dots (m-n+1)}{n!} x^{m-n} y^n,$$

when m is a positive integer, also when m is negative or fractional and $x > y$. When $x < y$ and m is fractional or negative the series must be taken in the form

$$(x + y)^m = y^m + \frac{m}{1} y^{m-1} x + \frac{m(m-1)}{2!} y^{m-2} x^2 + \dots \\ \dots + \frac{m(m-1) \dots (m-n+1)}{n!} y^{m-n} x^n.$$

Fourier's Series.

$$f(x) = \frac{1}{2} b_0 + b_1 \cos \frac{\pi x}{c} + b_2 \cos \frac{2\pi x}{c} + b_3 \cos \frac{3\pi x}{c} + \dots \\ + a_1 \sin \frac{\pi x}{c} + a_2 \sin \frac{2\pi x}{c} + a_3 \sin \frac{3\pi x}{c} + \dots$$

where

$$b_m = \frac{1}{c} \int_{-c}^{+c} f(x) \cos \frac{m\pi x}{c} dx, \\ a_m = \frac{1}{c} \int_{-c}^{+c} f(x) \sin \frac{m\pi x}{c} dx,$$

provided $f(x)$ is single valued, uniform, and continuous, and $c > x > -c$. For values of x lying between zero and c the function may be expanded in the form

$$f(x) = a_1 \sin \frac{\pi x}{c} + a_2 \sin \frac{2\pi x}{c} + a_3 \sin \frac{3\pi x}{c} + \dots,$$

where

$$a_m = \frac{2}{c} \int_0^c f(x) \sin \frac{m\pi x}{c} dx.$$

Also $f(x) = \frac{1}{2} b_0 + b_1 \cos \frac{\pi x}{c} + b_2 \cos \frac{2\pi x}{c} + b_3 \cos \frac{3\pi x}{c} + \dots,$

where

$$b_m = \frac{2}{c} \int_0^c f(x) \cos \frac{m\pi x}{c} dx.$$

General Series.

$$e^x = 1 + \frac{x}{1} + \frac{x^2}{2!} + \frac{x^3}{3!} + \dots + \frac{x^n}{n!}.$$

$$a^x = 1 + \frac{x \log a}{1} + \frac{(x \log a)^2}{2!} + \frac{(x \log a)^3}{3!} + \dots + \frac{(x \log a)^n}{n!}.$$

$$\log x = (x-1) - \frac{1}{2}(x-1)^2 + \frac{1}{3}(x-1)^3 - \dots + (-1)^{n-1} \frac{(x-1)^n}{n}; \quad 2 \geq x \geq 0.$$

$$\log x = \frac{x-1}{x} + \frac{1}{2} \left(\frac{x-1}{x} \right)^2 + \frac{1}{3} \left(\frac{x-1}{x} \right)^3 + \dots + \frac{1}{n} \left(\frac{x-1}{x} \right)^n; \quad x > \frac{1}{2}.$$

TABLE V. — DERIVATIVES.

U, V, W any functions; a, b, c constants.

$$\begin{array}{ll} \frac{\partial}{\partial x} x = 1; & \frac{\partial}{\partial x} U = a \frac{\partial U}{\partial x}. \\ \frac{\partial}{\partial x} (aU + bV + cW) = a \frac{\partial U}{\partial x} + b \frac{\partial V}{\partial x} + c \frac{\partial W}{\partial x}. & \\ \frac{\partial}{\partial x} UV = V \frac{\partial U}{\partial x} + U \frac{\partial V}{\partial x}; & \frac{\partial}{\partial x} \frac{U}{V} = \frac{V \frac{\partial U}{\partial x} - U \frac{\partial V}{\partial x}}{V^2}. \\ \frac{\partial}{\partial x} UVW = VW \frac{\partial U}{\partial x} + UW \frac{\partial V}{\partial x} + UV \frac{\partial W}{\partial x}. & \\ \frac{\partial}{\partial x} x^n = nx^{n-1}; & \frac{\partial}{\partial x} \frac{1}{x^n} = -n \frac{1}{x^{n+1}}. \\ \frac{\partial}{\partial x} \sqrt{x} = \frac{1}{2\sqrt{x}}; & \frac{\partial}{\partial x} U^n = nU^{n-1} \frac{\partial U}{\partial x}. \\ \frac{\partial}{\partial x} \log x = \frac{1}{x}; & \frac{\partial}{\partial x} \log aU = \frac{1}{U} \frac{\partial U}{\partial x}. \\ \frac{\partial}{\partial x} \log_a x = \frac{\log_a e}{x}; & \frac{\partial}{\partial x} a^x = a^x \log a. \\ \frac{\partial}{\partial x} a^b U = ba^b U \log a \frac{\partial U}{\partial x}; & \frac{\partial}{\partial x} e^{ax} = ae^{ax}. \\ \frac{\partial}{\partial x} e^{aU} = ae^{aU} \frac{\partial U}{\partial x}; & \frac{\partial}{\partial x} \sin x = \cos x. \\ \frac{\partial}{\partial x} \sin aU = a \cos aU \frac{\partial U}{\partial x}; & \frac{\partial}{\partial x} \cos x = -\sin x. \\ \frac{\partial}{\partial x} \tan x = \frac{1}{\cos^2 x} = \sec^2 x; & \frac{\partial}{\partial x} \cot x = \frac{-1}{\sin^2 x} = -\operatorname{cosec}^2 x. \\ \frac{\partial}{\partial x} \sec x = \tan x \sec x; & \frac{\partial}{\partial x} \operatorname{cosec} x = -\cot x \operatorname{cosec} x. \\ \frac{\partial}{\partial x} \log \sin x = \cot x; & \frac{\partial}{\partial x} \log \cos x = -\tan x. \end{array}$$

The following expressions for the derivatives of inverse functions hold for angles in the first and third quadrants. For angles in the second and fourth quadrants the signs should be reversed.

$$\begin{array}{ll} \frac{\partial}{\partial x} \sin^{-1} x = \frac{1}{\sqrt{1-x^2}}; & \frac{\partial}{\partial x} \cos^{-1} x = -\frac{1}{\sqrt{1-x^2}} \\ \frac{\partial}{\partial x} \tan^{-1} x = \frac{1}{1+x^2}; & \frac{\partial}{\partial x} \cot^{-1} x = -\frac{1}{1+x^2}. \end{array}$$

TABLE VI. — SOLUTION OF EQUATIONS.

The following algebraic expressions for the roots of equations of the second, third, and fourth degrees are in the form given by Merriman. (Merriman and Woodward, "Higher Mathematics"; Wiley and Sons, 1896.)

The Quadratic Equation.

Reduce to the form

$$x^2 + 2ax + b = 0.$$

Then the two roots are

$$x_1 = -a + \sqrt{a^2 - b}; \quad x_2 = -a - \sqrt{a^2 - b}$$

The Cubic Equation.

Reduce to the form

$$x^3 + 3ax^2 + 3bx + 2c = 0.$$

Compute the following auxiliary quantities:

$$B = -a^2 + b; \quad C = a^3 - \frac{3}{2}ab + c;$$

$$s_1 = (-C + \sqrt{B^3 + C^2})^{\frac{1}{3}}; \quad s_2 = (-C - \sqrt{B^3 + C^2})^{\frac{1}{3}}$$

Then the three roots are

$$x_1 = -a + (s_1 + s_2),$$

$$x_2 = -a - \frac{1}{2}(s_1 + s_2) + \frac{1}{2}\sqrt{-3}(s_1 - s_2),$$

$$x_3 = -a - \frac{1}{2}(s_1 + s_2) - \frac{1}{2}\sqrt{-3}(s_1 - s_2).$$

When $B^3 + C^2$ is negative the roots are all real but they cannot be determined numerically by the above formulæ owing to the complex nature of s_1 and s_2 . In such cases the numerical values of the roots can be determined only by some method of approximation.

The Quartic Equation.

Reduce to the form

$$x^4 + 4ax^3 + 6bx^2 + 4cx + d = 0.$$

Compute the following auxiliary quantities:

$$g = a^2 - b; \quad h = b^3 + c^2 - 2abc + dg; \quad k = \frac{4}{3}ac - b^2 - \frac{1}{3}d;$$

$$l = \frac{1}{2}(h + \sqrt{h^2 + k^3})^{\frac{1}{3}} + \frac{1}{2}(h - \sqrt{h^2 + k^3})^{\frac{1}{3}};$$

$$u = g + l; \quad v = 2g - l; \quad w = 4u^2 + 3k - 12gl.$$

Then the four roots are

$$x_1 = -a + \sqrt{u} + \sqrt{v + \sqrt{w}},$$

$$x_2 = -a + \sqrt{u} - \sqrt{v + \sqrt{w}},$$

$$x_3 = -a - \sqrt{u} + \sqrt{v - \sqrt{w}},$$

$$x_4 = -a - \sqrt{u} - \sqrt{v - \sqrt{w}},$$

in which the signs are to be used as written provided that $2a^3 - 3ab + c$ is a negative number; but if this is positive all radicals except \sqrt{w} are to be changed in sign.

The above expressions are irreducible when $h^2 + k^3$ is a negative number. In this case the given equation has either four imaginary roots or four real roots that can be determined numerically only by some method of approximation.

TABLE VII. — APPROXIMATE FORMULÆ.

In the following formulæ, α , β , δ , etc., represent quantities so small that their squares, higher powers, and products are negligible in comparison with unity. The limit of negligibility depends on the particular problem in hand. Most of the formulæ give results within one part in one million when the variables are equal to or less than 0.001.

1. $(1 + \alpha)^n = 1 + n\alpha$; $(1 - \alpha)^n = 1 - n\alpha$.
2. $(1 + \alpha)^2 = 1 + 2\alpha$; $(1 - \alpha)^2 = 1 - 2\alpha$.
3. $\sqrt{1 + \alpha} = 1 + \frac{1}{2}\alpha$; $\sqrt{1 - \alpha} = 1 - \frac{1}{2}\alpha$.
4. $\frac{1}{1 + \alpha} = 1 - \alpha$; $\frac{1}{1 - \alpha} = 1 + \alpha$.
5. $\frac{1}{(1 + \alpha)^n} = 1 - n\alpha$; $\frac{1}{(1 - \alpha)^n} = 1 + n\alpha$.
6. $\frac{1}{\sqrt[3]{1 + \alpha}} = 1 - \frac{\alpha}{3}$; $\frac{1}{\sqrt[3]{1 - \alpha}} = 1 + \frac{\alpha}{3}$.
7. $(1 \pm \alpha)(1 \pm \beta)(1 \pm \delta) \dots = 1 \pm \alpha \pm \beta \pm \delta \pm \dots$
8. $\frac{(1 \pm \alpha)(1 \pm \beta) \dots}{(1 \pm \delta)(1 \pm \epsilon) \dots} = 1 \pm \alpha \pm \beta \pm \dots \mp \delta \mp \epsilon \mp \dots$
9. $(x + \alpha)^2 = x^2 \left(1 + \frac{\alpha}{x}\right)^2 = x^2 + 2x\alpha$.

When the angle α , expressed in radians, is small in comparison with unity a first approximation gives

10. $\sin \alpha = \alpha$; $\sin(x \pm \alpha) = \sin x \pm \alpha \cos x$.
11. $\cos \alpha = 1$; $\cos(x \pm \alpha) = \cos x \mp \alpha \sin x$.
12. $\tan \alpha = \alpha$; $\tan(x \pm \alpha) = \tan x \pm \frac{\alpha}{\cos^2 x}$.

The second approximation gives

13. $\sin \alpha = \alpha - \frac{\alpha^3}{6}$; $\sin^2 \alpha = \alpha^2 \left(1 - \frac{\alpha^2}{3}\right)$.
14. $\cos \alpha = 1 - \frac{\alpha^2}{2}$; $\cos^2 \alpha = 1 - \alpha^2$.
15. $\tan \alpha = \alpha + \frac{\alpha^3}{3}$; $\tan^2 \alpha = \alpha^2 \left(1 + \frac{2}{3}\alpha^2\right)$.

(Kohlrausch, "Praktische Physik.")

TABLE VIII. — NUMERICAL CONSTANTS.

	Logarithm.
Base of Napierian logarithms: $e = 2.7182818 \dots\dots\dots$	0.4342945
Modulus of Napierian log.: $M = \frac{1}{\log e} = 2.30259 \dots\dots\dots$	0.3622157
Modulus of common log.: $\frac{1}{M} = \log e = 0.4342945 \dots\dots\dots$	$\bar{1}.6377843$
$\log_e x = M \log_{10} x$	
$\frac{\text{Circumference}}{\text{Diameter}}: \pi = 3.14159265 \dots\dots\dots$	0.4971499
$2\pi = 6.28318530 \dots\dots\dots$	0.7981799
$\frac{1}{\pi} = 0.3183099 \dots\dots\dots$	$\bar{1}.5028501$
$\pi^2 = 9.8696044 \dots\dots\dots$	0.9942998
$\sqrt{\pi} = 1.7724539 \dots\dots\dots$	0.2485749
$\frac{\pi}{4} = 0.7853982 \dots\dots\dots$	$\bar{1}.8950899$
$\frac{\pi}{6} = 0.5235988 \dots\dots\dots$	$\bar{1}.7189986$
$\omega =$ Precision constant; $k =$ Unit error; $A =$ Average error;	
$M =$ Mean error; $E =$ Probable error.	
$\frac{A\omega}{k} = 0.31831 \dots\dots\dots$	$\bar{1}.5028501$
$\frac{M\omega}{k} = 0.39894 \dots\dots\dots$	$\bar{1}.6009101$
$\frac{E\omega}{k} = 0.26908 \dots\dots\dots$	$\bar{1}.4298888$
$\frac{M}{A} = 1.25331 \dots\dots\dots$	0.0980600
$\frac{E}{A} = 0.84535 \dots\dots\dots$	$\bar{1}.9270387$
$\frac{E}{M} = 0.67449 \dots\dots\dots$	$\bar{1}.8289787$

TABLE IX. — EXPONENTIAL FUNCTIONS.

x	$\log_{10}(e^x)$	e^x	e^{-x}	x	$\log_{10}(e^x)$	e^x	e^{-x}
0.0	0.00000	1.0000	1.000000	5.0	2.17147	148.41	0.006738
0.1	0.04343	1.1052	0.904837	5.1	2.21490	164.02	0.006097
0.2	0.08686	1.2214	0.818731	5.2	2.25833	181.27	0.005517
0.3	0.13029	1.3499	0.740818	5.3	2.30176	200.34	0.004992
0.4	0.17372	1.4918	0.670320	5.4	2.34519	221.41	0.004517
0.5	0.21715	1.6487	0.606531	5.5	2.38862	244.69	0.004087
0.6	0.26058	1.8221	0.548812	5.6	2.43205	270.43	0.003698
0.7	0.30401	2.0138	0.496585	5.7	2.47548	298.87	0.003346
0.8	0.34744	2.2255	0.449329	5.8	2.51891	330.30	0.003028
0.9	0.39087	2.4596	0.406570	5.9	2.56234	365.04	0.002739
1.0	0.43429	2.7183	0.367879	6.0	2.60577	403.43	0.002479
1.1	0.47772	3.0042	0.332871	6.1	2.64920	445.86	0.002243
1.2	0.52115	3.3201	0.301194	6.2	2.69263	492.75	0.002029
1.3	0.56458	3.6693	0.272532	6.3	2.73606	544.57	0.001836
1.4	0.60801	4.0552	0.246597	6.4	2.77948	601.85	0.001662
1.5	0.65144	4.4817	0.223130	6.5	2.82291	665.14	0.001503
1.6	0.69487	4.9530	0.201897	6.6	2.86634	735.10	0.001360
1.7	0.73830	5.4739	0.182684	6.7	2.90977	812.41	0.001231
1.8	0.78173	6.0496	0.165299	6.8	2.95320	897.85	0.001114
1.9	0.82516	6.6859	0.149569	6.9	2.99663	992.27	0.001008
2.0	0.86859	7.3891	0.135335	7.0	3.04006	1096.6	0.000912
2.1	0.91202	8.1662	0.122456	7.1	3.08349	1212.0	0.000825
2.2	0.95545	9.0250	0.110803	7.2	3.12692	1339.4	0.000747
2.3	0.99888	9.9742	0.100259	7.3	3.17035	1480.3	0.000676
2.4	1.04231	11.023	0.090718	7.4	3.21378	1636.0	0.000611
2.5	1.08574	12.182	0.082085	7.5	3.25721	1808.0	0.000553
2.6	1.12917	13.464	0.074274	7.6	3.30064	1998.2	0.000500
2.7	1.17260	14.880	0.067206	7.7	3.34407	2208.3	0.000453
2.8	1.21602	16.445	0.060810	7.8	3.38750	2440.6	0.000410
2.9	1.25945	18.174	0.055023	7.9	3.43093	2697.3	0.000371
3.0	1.30288	20.086	0.049787	8.0	3.47436	2981.0	0.000335
3.1	1.34631	22.198	0.045049	8.1	3.51779	3294.5	0.000304
3.2	1.38974	24.533	0.040762	8.2	3.56121	3641.0	0.000275
3.3	1.43317	27.113	0.036883	8.3	3.60464	4023.9	0.000249
3.4	1.47660	29.964	0.033373	8.4	3.64807	4447.1	0.000225
3.5	1.52003	33.115	0.030197	8.5	3.69150	4914.8	0.000203
3.6	1.56346	36.598	0.027324	8.6	3.73493	5431.7	0.000184
3.7	1.60689	40.447	0.024724	8.7	3.77836	6002.9	0.000167
3.8	1.65032	44.701	0.022371	8.8	3.82179	6634.2	0.000151
3.9	1.69375	49.402	0.020242	8.9	3.86522	7332.0	0.000136
4.0	1.73718	54.598	0.018316	9.0	3.90865	8103.1	0.000123
4.1	1.78061	60.340	0.016573	9.1	3.95208	8955.3	0.000112
4.2	1.82404	66.686	0.014996	9.2	3.99551	9897.1	0.000101
4.3	1.86747	73.700	0.013569	9.3	4.03894	10938.	0.000091
4.4	1.91090	81.451	0.012277	9.4	4.08237	12088.	0.000083
4.5	1.95433	90.017	0.011109	9.5	4.12580	13360.	0.000075
4.6	1.99775	99.484	0.010052	9.6	4.16923	14765.	0.000068
4.7	2.04118	109.95	0.009095	9.7	4.21266	16318.	0.000061
4.8	2.08461	121.51	0.008230	9.8	4.25609	18034.	0.000055
4.9	2.12804	134.29	0.007447	9.9	4.29952	19930.	0.000050
5.0	2.17147	148.41	0.006738	10.0	4.34294	22026.	0.000045

Taken from Glaisher's "Tables of the Exponential Function," *Trans. Cambridge Phil. Soc.*, vol. xiii, 1883. This volume also contains a "Table of the Descending Exponential to Twelve or Fourteen Places of Decimals," by F. W. Newman.

TABLE X.—EXPONENTIAL FUNCTIONS.
Value of e^{x^2} and e^{-x^2} and their logarithms.

x	e^{x^2}	$\log e^{x^2}$	e^{-x^2}	$\log e^{-x^2}$
0.1	1.0101	0.00434	0.99005	$\bar{1}.99566$
0.2	1.0408	0.01737	0.96079	$\bar{1}.98263$
0.3	1.0942	0.03909	0.91393	$\bar{1}.96091$
0.4	1.1735	0.06949	0.85214	$\bar{1}.93051$
0.5	1.2840	0.10857	0.77880	$\bar{1}.89143$
0.6	1.4333	0.15635	0.69768	$\bar{1}.84365$
0.7	1.6323	0.21280	0.61263	$\bar{1}.78720$
0.8	1.8965	0.27795	0.52729	$\bar{1}.72205$
0.9	2.2479	0.35178	0.44486	$\bar{1}.64822$
1.0	2.7183	0.43429	0.36788	$\bar{1}.56571$
1.1	3.3535	0.52550	0.29820	$\bar{1}.47450$
1.2	4.2207	0.62538	0.23693	$\bar{1}.37462$
1.3	5.4195	0.73396	0.18452	$\bar{1}.26604$
1.4	7.0993	0.85122	0.14086	$\bar{1}.14878$
1.5	9.4877	0.97716	0.10540	$\bar{1}.02284$
1.6	1.2936×10	1.11179	0.77305×10^{-1}	$\bar{2}.88821$
1.7	1.7993×10	1.25511	0.55576×10^{-1}	$\bar{2}.74489$
1.8	2.5534×10	1.40711	0.39164×10^{-1}	$\bar{2}.59289$
1.9	3.6966×10	1.56780	0.27052×10^{-1}	$\bar{2}.43220$
2.0	5.4598×10	1.73718	0.18316×10^{-1}	$\bar{2}.26282$
2.1	8.2269×10	1.91524	0.12155×10^{-1}	$\bar{2}.08476$
2.2	1.2647×10^2	2.10199	0.79071×10^{-2}	$\bar{3}.89801$
2.3	1.9834×10^2	2.29742	0.50417×10^{-2}	$\bar{3}.70258$
2.4	3.1735×10^2	2.50154	0.31511×10^{-2}	$\bar{3}.49846$
2.5	5.1801×10^2	2.71434	0.19305×10^{-2}	$\bar{3}.28566$
2.6	8.6264×10^2	2.93583	0.11592×10^{-2}	$\bar{3}.06417$
2.7	1.4656×10^3	3.16601	0.68232×10^{-3}	$\bar{4}.83399$
2.8	2.5402×10^3	3.40487	0.39367×10^{-3}	$\bar{4}.59513$
2.9	4.4918×10^3	3.65242	0.22263×10^{-3}	$\bar{4}.34758$
3.0	8.1031×10^3	3.90865	0.12341×10^{-3}	$\bar{4}.09135$
3.1	1.4913×10^4	4.17357	0.67055×10^{-4}	$\bar{5}.82643$
3.2	2.8001×10^4	4.44718	0.35713×10^{-4}	$\bar{5}.55282$
3.3	5.3637×10^4	4.72947	0.18644×10^{-4}	$\bar{5}.27053$
3.4	1.0482×10^5	5.02044	0.95403×10^{-5}	$\bar{6}.97956$
3.5	2.0898×10^5	5.32011	0.47851×10^{-5}	$\bar{6}.67989$
3.6	4.2507×10^5	5.62846	0.23526×10^{-5}	$\bar{6}.37154$
3.7	8.8204×10^5	5.94549	0.11337×10^{-5}	$\bar{6}.05451$
3.8	1.8673×10^6	6.27121	0.53554×10^{-6}	$\bar{7}.72879$
3.9	4.0329×10^6	6.60562	0.24796×10^{-6}	$\bar{7}.39438$
4.0	8.8861×10^6	6.94871	0.11254×10^{-6}	$\bar{7}.05129$
4.1	1.9975×10^7	7.30049	0.50062×10^{-7}	$\bar{8}.69951$
4.2	4.5809×10^7	7.66095	0.21830×10^{-7}	$\bar{8}.33905$
4.3	1.0718×10^8	8.03011	0.93302×10^{-8}	$\bar{9}.96989$
4.4	2.5582×10^8	8.40794	0.39089×10^{-8}	$\bar{9}.59206$
4.5	6.2296×10^8	8.79446	0.16052×10^{-8}	$\bar{9}.20554$
4.6	1.5476×10^9	9.18967	0.64614×10^{-9}	$\bar{10}.81033$
4.7	3.9226×10^9	9.59357	0.25494×10^{-9}	$\bar{10}.40643$
4.8	1.0143×10^{10}	10.00615	0.98594×10^{-10}	$\bar{11}.99385$
4.9	2.6755×10^{10}	10.42741	0.37376×10^{-10}	$\bar{11}.57259$
5.0	7.2005×10^{10}	10.85736	0.13888×10^{-10}	$\bar{11}.14264$

TABLE XI. — VALUES OF THE PROBABILITY INTEGRAL.

$$P_{\Delta} = \frac{2}{\sqrt{\pi}} \int_0^t e^{-t^2} dt; \quad t = \sqrt{\pi} \omega \frac{\Delta}{k}.$$

<i>t</i>	<i>P</i> _Δ	Diff.	<i>t</i>	<i>P</i> _Δ	Diff.	<i>t</i>	<i>P</i> _Δ	Diff.	<i>t</i>	<i>P</i> _Δ	Diff.
0.00	0.00000	1128	0.50	0.52050	874	1.00	0.84270	411	1.50	0.96611	117
0.01	0.01128	1128	0.51	0.52924	866	1.01	0.84681	403	1.51	0.96728	113
0.02	0.02256	1128	0.52	0.53790	856	1.02	0.85084	394	1.52	0.96841	111
0.03	0.03384	1127	0.53	0.54646	848	1.03	0.85478	387	1.53	0.96952	107
0.04	0.04511	1126	0.54	0.55494	838	1.04	0.85865	379	1.54	0.97059	103
0.05	0.05637	1125	0.55	0.56332	830	1.05	0.86244	370	1.55	0.97162	101
0.06	0.06762	1124	0.56	0.57162	820	1.06	0.86614	363	1.56	0.97263	97
0.07	0.07886	1122	0.57	0.57982	810	1.07	0.86977	356	1.57	0.97360	95
0.08	0.09008	1120	0.58	0.58792	802	1.08	0.87333	347	1.58	0.97455	91
0.09	0.10129	1118	0.59	0.59594	792	1.09	0.87680	341	1.59	0.97546	89
0.10	0.11246	1116	0.60	0.60386	782	1.10	0.88021	332	1.60	0.97635	86
0.11	0.12362	1114	0.61	0.61168	773	1.11	0.88353	326	1.61	0.97721	83
0.12	0.13476	1111	0.62	0.61941	764	1.12	0.88679	318	1.62	0.97804	80
0.13	0.14587	1108	0.63	0.62705	754	1.13	0.88997	311	1.63	0.97884	78
0.14	0.15695	1105	0.64	0.63459	744	1.14	0.89308	304	1.64	0.97962	76
0.15	0.16800	1101	0.65	0.64203	735	1.15	0.89612	298	1.65	0.98038	72
0.16	0.17901	1098	0.66	0.64938	725	1.16	0.89910	290	1.66	0.98110	71
0.17	0.18999	1095	0.67	0.65663	715	1.17	0.90200	284	1.67	0.98181	68
0.18	0.20094	1090	0.68	0.66378	706	1.18	0.90484	277	1.68	0.98249	66
0.19	0.21184	1086	0.69	0.67084	696	1.19	0.90761	270	1.69	0.98315	64
0.20	0.22270	1082	0.70	0.67780	687	1.20	0.91031	265	1.70	0.98379	62
0.21	0.23352	1078	0.71	0.68467	676	1.21	0.91296	257	1.71	0.98441	59
0.22	0.24430	1072	0.72	0.69143	667	1.22	0.91553	252	1.72	0.98500	58
0.23	0.25502	1068	0.73	0.69810	658	1.23	0.91805	246	1.73	0.98558	55
0.24	0.26570	1063	0.74	0.70468	648	1.24	0.92051	239	1.74	0.98613	54
0.25	0.27633	1057	0.75	0.71116	638	1.25	0.92290	234	1.75	0.98667	52
0.26	0.28690	1052	0.76	0.71754	628	1.26	0.92524	227	1.76	0.98719	50
0.27	0.29742	1046	0.77	0.72382	619	1.27	0.92751	222	1.77	0.98769	48
0.28	0.30788	1040	0.78	0.73001	609	1.28	0.92973	217	1.78	0.98817	47
0.29	0.31828	1035	0.79	0.73610	600	1.29	0.93190	211	1.79	0.98864	45
0.30	0.32863	1028	0.80	0.74210	590	1.30	0.93401	205	1.80	0.98909	43
0.31	0.33891	1022	0.81	0.74800	581	1.31	0.93606	201	1.81	0.98952	42
0.32	0.34913	1015	0.82	0.75381	571	1.32	0.93807	195	1.82	0.98994	41
0.33	0.35928	1008	0.83	0.75952	562	1.33	0.94002	189	1.83	0.99035	39
0.34	0.36936	1002	0.84	0.76514	553	1.34	0.94191	185	1.84	0.99074	37
0.35	0.37938	995	0.85	0.77067	543	1.35	0.94376	180	1.85	0.99111	36
0.36	0.38933	988	0.86	0.77610	534	1.36	0.94556	175	1.86	0.99147	35
0.37	0.39921	980	0.87	0.78144	525	1.37	0.94731	171	1.87	0.99182	34
0.38	0.40901	973	0.88	0.78669	515	1.38	0.94902	165	1.88	0.99216	32
0.39	0.41874	965	0.89	0.79184	507	1.39	0.95067	162	1.89	0.99248	31
0.40	0.42839	958	0.90	0.79691	497	1.40	0.95229	156	1.90	0.99279	30
0.41	0.43797	950	0.91	0.80188	489	1.41	0.95385	153	1.91	0.99309	29
0.42	0.44747	942	0.92	0.80677	479	1.42	0.95538	148	1.92	0.99338	28
0.43	0.45689	934	0.93	0.81156	471	1.43	0.95686	144	1.93	0.99366	26
0.44	0.46623	925	0.94	0.81627	462	1.44	0.95830	140	1.94	0.99392	26
0.45	0.47548	918	0.95	0.82089	453	1.45	0.95970	135	1.95	0.99418	25
0.46	0.48466	909	0.96	0.82542	445	1.46	0.96105	132	1.96	0.99443	23
0.47	0.49375	900	0.97	0.82987	436	1.47	0.96237	128	1.97	0.99466	23
0.48	0.50275	892	0.98	0.83423	428	1.48	0.96365	125	1.98	0.99489	22
0.49	0.51167	883	0.99	0.83851	419	1.49	0.96490	121	1.99	0.99511	21
0.50	0.52050		1.00	0.84270		1.50	0.96611		2.00	0.99532	22
									∞	1.00000	

(Chauvenet, "Spherical and Practical Astronomy.")

TABLE XII.—VALUES OF THE PROBABILITY INTEGRAL.

$$P_s = \frac{2}{\sqrt{\pi}} \int_0^{sS} e^{-t^2} dt; \quad S = \frac{\Delta}{E}$$

S	0	1	2	3	4	5	6	7	8	9
0.0	.00000	.00538	.01076	.01614	.02152	.02690	.03228	.03766	.04303	.04840
0.1	.05378	.05914	.06451	.06987	.07523	.08059	.08594	.09129	.09663	.10197
0.2	.10731	.11264	.11796	.12328	.12860	.13391	.13921	.14451	.14980	.15508
0.3	.16035	.16562	.17088	.17614	.18138	.18662	.19185	.19707	.20229	.20749
0.4	.21268	.21787	.22304	.22821	.23336	.23851	.24364	.24876	.25388	.25898
0.5	.26407	.26915	.27421	.27927	.28431	.28934	.29436	.29936	.30435	.30933
0.6	.31430	.31925	.32419	.32911	.33402	.33892	.34380	.34866	.35352	.35835
0.7	.36317	.36798	.37277	.37755	.38231	.38705	.39178	.39649	.40118	.40586
0.8	.41052	.41517	.41979	.42440	.42899	.43357	.43813	.44267	.44719	.45169
0.9	.45618	.46064	.46509	.46952	.47393	.47832	.48270	.48605	.49139	.49570
1.0	.50000	.50428	.50853	.51277	.51699	.52119	.52537	.52952	.53366	.53778
1.1	.54188	.54595	.55001	.55404	.55806	.56205	.56602	.56998	.57391	.57782
1.2	.58171	.58558	.58942	.59325	.59705	.60083	.60460	.60833	.61205	.61575
1.3	.61942	.62308	.62671	.63032	.63391	.63747	.64102	.64454	.64804	.65152
1.4	.65498	.65841	.66182	.66521	.66858	.67193	.67526	.67856	.68184	.68510
1.5	.68833	.69155	.69474	.69791	.70106	.70419	.70729	.71038	.71344	.71648
1.6	.71949	.72249	.72546	.72841	.73134	.73425	.73714	.74000	.74285	.74567
1.7	.74847	.75124	.75400	.75674	.75945	.76214	.76481	.76746	.77009	.77270
1.8	.77528	.77785	.78039	.78291	.78542	.78790	.79036	.79280	.79522	.79761
1.9	.79999	.80235	.80469	.80700	.80930	.81158	.81383	.81607	.81828	.82048
2.0	.82266	.82481	.82695	.82907	.83117	.83324	.83530	.83734	.83936	.84137
2.1	.84335	.84531	.84726	.84919	.85109	.85298	.85486	.85671	.85854	.86036
2.2	.86216	.86394	.86570	.86745	.86917	.87088	.87258	.87425	.87591	.87755
2.3	.87918	.88078	.88237	.88395	.88550	.88705	.88857	.89008	.89157	.89304
2.4	.89450	.89595	.89738	.89879	.90019	.90157	.90293	.90428	.90562	.90694
2.5	.90825	.90954	.91082	.91208	.91332	.91456	.91578	.91698	.91817	.91935
2.6	.92051	.92166	.92280	.92392	.92503	.92613	.92721	.92828	.92934	.93038
2.7	.93141	.93243	.93344	.93443	.93541	.93638	.93734	.93828	.93922	.94014
2.8	.94105	.94195	.94284	.94371	.94458	.94543	.94627	.94711	.94793	.94874
2.9	.94954	.95033	.95111	.95187	.95263	.95338	.95412	.95485	.95557	.95628
3	.95698	.96346	.96910	.97397	.97817	.98176	.98482	.98743	.98962	.99147
4	.99302	.99431	.99539	.99627	.99700	.99760	.99808	.99848	.99879	.99905
5	.99926	.99943	.99956	.99966	.99974	.99980	.99985	.99988	.99991	.99993

TABLE XIII.—CHAUVENET'S CRITERION.

N	T	N	T	N	T
3	2.05	13	3.07	23	3.40
4	2.27	14	3.11	24	3.43
5	2.44	15	3.15	25	3.45
6	2.57	16	3.19	30	3.55
7	2.67	17	3.22	40	3.70
8	2.76	18	3.26	50	3.82
9	2.84	19	3.29	75	4.02
10	2.91	20	3.32	100	4.16
11	2.97	21	3.35	200	4.48
12	3.02	22	3.38	500	4.90

TABLE XIV. — FOR COMPUTING PROBABLE ERRORS BY FORMULÆ
(31) AND (32).

N	$\frac{0.6745}{\sqrt{N-1}}$	$\frac{0.6745}{\sqrt{N(N-1)}}$	N	$\frac{0.6745}{\sqrt{N-1}}$	$\frac{0.6745}{\sqrt{N(N-1)}}$
			40	0.1080	0.0171
			41	0.1066	0.0167
2	0.6745	0.4769	42	0.1053	0.0163
3	0.4769	0.2754	43	0.1041	0.0159
4	0.3894	0.1947	44	0.1029	0.0155
5	0.3372	0.1508	45	0.1017	0.0152
6	0.3016	0.1231	46	0.1005	0.0148
7	0.2754	0.1041	47	0.0994	0.0145
8	0.2549	0.0901	48	0.0984	0.0142
9	0.2385	0.0795	49	0.0974	0.0139
10	0.2248	0.0711	50	0.0964	0.0136
11	0.2133	0.0643	51	0.0954	0.0134
12	0.2029	0.0587	52	0.0944	0.0131
13	0.1947	0.0540	53	0.0935	0.0128
14	0.1871	0.0500	54	0.0926	0.0126
15	0.1803	0.0465	55	0.0918	0.0124
16	0.1742	0.0435	56	0.0909	0.0122
17	0.1686	0.0409	57	0.0901	0.0119
18	0.1636	0.0386	58	0.0893	0.0117
19	0.1590	0.0365	59	0.0886	0.0115
20	0.1547	0.0346	60	0.0878	0.0113
21	0.1508	0.0329	61	0.0871	0.0111
22	0.1472	0.0314	62	0.0864	0.0110
23	0.1438	0.0300	63	0.0857	0.0108
24	0.1406	0.0287	64	0.0850	0.0106
25	0.1377	0.0275	65	0.0843	0.0105
26	0.1349	0.0265	66	0.0837	0.0103
27	0.1323	0.0255	67	0.0830	0.0101
28	0.1298	0.0245	68	0.0824	0.0100
29	0.1275	0.0237	69	0.0818	0.0098
30	0.1252	0.0229	70	0.0812	0.0097
31	0.1231	0.0221	71	0.0806	0.0096
32	0.1211	0.0214	72	0.0800	0.0094
33	0.1192	0.0208	73	0.0795	0.0093
34	0.1174	0.0201	74	0.0789	0.0092
35	0.1157	0.0196	75	0.0784	0.0091
36	0.1140	0.0190	80	0.0759	0.0085
37	0.1124	0.0185	85	0.0736	0.0080
38	0.1109	0.0180	90	0.0713	0.0075
39	0.1094	0.0175	100	0.0678	0.0068

(Merriman, "Least Squares.")

TABLE XV.—FOR COMPUTING PROBABLE ERRORS BY FORMULÆ (34).

N	$\frac{0.8453}{\sqrt{N(N-1)}}$	$\frac{0.8453}{N\sqrt{N-1}}$	N	$\frac{0.8453}{\sqrt{N(N-1)}}$	$\frac{0.8453}{N\sqrt{N-1}}$
			40	0.0214	0.0034
			41	0.0209	0.0033
2	0.5978	0.4227	42	0.0204	0.0031
3	0.3451	0.1993	43	0.0199	0.0030
4	0.2440	0.1220	44	0.0194	0.0029
			45	0.0190	0.0028
5	0.1890	0.0845	46	0.0186	0.0027
6	0.1543	0.0630	47	0.0182	0.0027
7	0.1304	0.0493	48	0.0178	0.0026
8	0.1130	0.0399	49	0.0174	0.0025
9	0.0996	0.0332			
			50	0.0171	0.0024
10	0.0891	0.0282	51	0.0167	0.0023
11	0.0806	0.0243	52	0.0164	0.0023
12	0.0736	0.0212	53	0.0161	0.0022
13	0.0677	0.0188	54	0.0158	0.0022
14	0.0627	0.0167			
			55	0.0155	0.0021
15	0.0583	0.0151	56	0.0152	0.0020
16	0.0546	0.0136	57	0.0150	0.0020
17	0.0513	0.0124	58	0.0147	0.0019
18	0.0483	0.0114	59	0.0145	0.0019
19	0.0457	0.0105			
			60	0.0142	0.0018
20	0.0434	0.0097	61	0.0140	0.0018
21	0.0412	0.0090	62	0.0137	0.0017
22	0.0393	0.0084	63	0.0135	0.0017
23	0.0376	0.0078	64	0.0133	0.0017
24	0.0360	0.0073			
			65	0.0131	0.0016
25	0.0345	0.0069	66	0.0129	0.0016
26	0.0332	0.0065	67	0.0127	0.0016
27	0.0319	0.0061	68	0.0125	0.0015
28	0.0307	0.0058	69	0.0123	0.0015
29	0.0297	0.0055			
			70	0.0122	0.0015
30	0.0287	0.0052	71	0.0120	0.0014
31	0.0277	0.0050	72	0.0118	0.0014
32	0.0268	0.0047	73	0.0117	0.0014
33	0.0260	0.0045	74	0.0115	0.0013
34	0.0252	0.0043			
			75	0.0113	0.0013
35	0.0245	0.0041	80	0.0106	0.0012
36	0.0238	0.0040	85	0.0100	0.0011
37	0.0232	0.0038	90	0.0095	0.0010
38	0.0225	0.0037	100	0.0085	0.0008
39	0.0220	0.0035			

(Merriman, "Least Squares.")

TABLE XVI.—SQUARES OF NUMBERS.

<i>n</i>	0	1	2	3	4	5	6	7	8	9	Diff.
1.0	1.000	1.020	1.040	1.061	1.082	1.103	1.124	1.145	1.166	1.188	22
1.1	1.210	1.232	1.254	1.277	1.300	1.323	1.346	1.369	1.392	1.416	24
1.2	1.440	1.464	1.488	1.513	1.538	1.563	1.588	1.613	1.638	1.664	26
1.3	1.690	1.716	1.742	1.769	1.796	1.823	1.850	1.877	1.904	1.932	28
1.4	1.960	1.988	2.016	2.045	2.074	2.103	2.132	2.161	2.190	2.220	30
1.5	2.250	2.280	2.310	2.341	2.372	2.403	2.434	2.465	2.496	2.528	32
1.6	2.560	2.592	2.624	2.657	2.690	2.723	2.756	2.789	2.822	2.856	34
1.7	2.890	2.924	2.958	2.993	3.028	3.063	3.098	3.133	3.168	3.204	36
1.8	3.240	3.276	3.312	3.349	3.386	3.423	3.460	3.497	3.534	3.572	38
1.9	3.610	3.648	3.686	3.725	3.764	3.803	3.842	3.881	3.920	3.960	40
2.0	4.000	4.040	4.080	4.121	4.162	4.203	4.244	4.285	4.326	4.368	42
2.1	4.410	4.452	4.494	4.537	4.580	4.623	4.666	4.709	4.752	4.796	44
2.2	4.840	4.884	4.928	4.973	5.018	5.063	5.108	5.153	5.198	5.244	46
2.3	5.290	5.336	5.382	5.429	5.476	5.523	5.570	5.617	5.664	5.712	48
2.4	5.760	5.808	5.856	5.905	5.954	6.003	6.052	6.101	6.150	6.200	50
2.5	6.250	6.300	6.350	6.401	6.452	6.503	6.554	6.605	6.656	6.708	52
2.6	6.760	6.812	6.864	6.917	6.970	7.023	7.076	7.129	7.182	7.236	54
2.7	7.290	7.344	7.398	7.453	7.508	7.563	7.618	7.673	7.728	7.784	56
2.8	7.840	7.896	7.952	8.009	8.066	8.123	8.180	8.237	8.294	8.352	58
2.9	8.410	8.468	8.526	8.585	8.644	8.703	8.762	8.821	8.880	8.940	60
3.0	9.000	9.060	9.120	9.181	9.242	9.303	9.364	9.425	9.486	9.548	62
3.1	9.610	9.672	9.734	9.797	9.860	9.923	9.986	10.05	10.11	10.18	6
3.2	10.24	10.30	10.37	10.43	10.50	10.56	10.63	10.69	10.76	10.82	7
3.3	10.89	10.96	11.02	11.09	11.16	11.22	11.29	11.36	11.42	11.49	7
3.4	11.56	11.63	11.70	11.76	11.83	11.90	11.97	12.04	12.11	12.18	7
3.5	12.25	12.32	12.39	12.46	12.53	12.60	12.67	12.74	12.82	12.89	7
3.6	12.96	13.03	13.10	13.18	13.25	13.32	13.40	13.47	13.54	13.62	7
3.7	13.69	13.76	13.84	13.91	13.99	14.06	14.14	14.21	14.29	14.36	8
3.8	14.44	14.52	14.59	14.67	14.75	14.82	14.90	14.98	15.05	15.13	8
3.9	15.21	15.29	15.37	15.44	15.52	15.60	15.68	15.76	15.84	15.92	8
4.0	16.00	16.08	16.16	16.24	16.32	16.40	16.48	16.56	16.65	16.73	8
4.1	16.81	16.89	16.97	17.06	17.14	17.22	17.31	17.39	17.47	17.56	8
4.2	17.64	17.72	17.81	17.89	17.98	18.06	18.15	18.23	18.32	18.40	9
4.3	18.49	18.58	18.66	18.75	18.84	18.92	19.01	19.10	19.18	19.27	9
4.4	19.36	19.45	19.54	19.62	19.71	19.80	19.89	19.98	20.07	20.16	9
4.5	20.25	20.34	20.43	20.52	20.61	20.70	20.79	20.88	20.98	21.07	9
4.6	21.16	21.25	21.34	21.44	21.53	21.62	21.72	21.81	21.90	22.00	9
4.7	22.09	22.18	22.28	22.37	22.47	22.56	22.66	22.75	22.85	22.94	10
4.8	23.04	23.14	23.23	23.33	23.43	23.52	23.62	23.72	23.81	23.91	10
4.9	24.01	24.11	24.21	24.30	24.40	24.50	24.60	24.70	24.80	24.90	10
5.0	25.00	25.10	25.20	25.30	25.40	25.50	25.60	25.70	25.81	25.91	10
5.1	26.01	26.11	26.21	26.32	26.42	26.52	26.63	26.73	26.83	26.94	10
5.2	27.04	27.14	27.25	27.35	27.46	27.56	27.67	27.77	27.88	27.98	11
5.3	28.09	28.20	28.30	28.41	28.52	28.62	28.73	28.84	28.94	29.05	11
5.4	29.16	29.27	29.38	29.48	29.59	29.70	29.81	29.92	30.03	30.14	11
<i>n</i>	0	1	2	3	4	5	6	7	8	9	Diff.

(Merriman, "Least Squares.")

TABLE XVI. — SQUARES OF NUMBERS (Concluded).

<i>n</i>	0	1	2	3	4	5	6	7	8	9	Diff.
5.5	30.25	30.36	30.47	30.58	30.69	30.80	30.91	31.02	31.14	31.25	11
5.6	31.36	31.47	31.58	31.70	31.81	31.92	32.04	32.15	32.26	32.38	11
5.7	32.49	32.60	32.72	32.83	32.95	33.06	33.18	33.29	33.41	33.52	12
5.8	33.64	33.76	33.87	33.99	34.11	34.22	34.34	34.46	34.57	34.69	12
5.9	34.81	34.93	35.05	35.16	35.28	35.40	35.52	35.64	35.76	35.88	12
6.0	36.00	36.12	36.24	36.36	36.48	36.60	36.72	36.84	36.97	37.09	12
6.1	37.21	37.33	37.45	37.58	37.70	37.82	37.95	38.07	38.19	38.32	12
6.2	38.44	38.56	38.69	38.81	38.94	39.06	39.19	39.31	39.44	39.56	13
6.3	39.69	39.82	39.94	40.07	40.20	40.32	40.45	40.58	40.70	40.83	13
6.4	40.96	41.09	41.22	41.34	41.47	41.60	41.73	41.86	41.99	42.12	13
6.5	42.25	42.38	42.51	42.64	42.77	42.90	43.03	43.16	43.30	43.43	13
6.6	43.56	43.69	43.82	43.96	44.09	44.22	44.36	44.49	44.62	44.76	13
6.7	44.89	45.02	45.16	45.29	45.43	45.56	45.70	45.83	45.97	46.10	14
6.8	46.24	46.38	46.51	46.65	46.79	46.92	47.06	47.20	47.33	47.47	14
6.9	47.61	47.75	47.89	48.02	48.16	48.30	48.44	48.58	48.72	48.86	14
7.0	49.00	49.14	49.28	49.42	49.56	49.70	49.84	49.98	50.13	50.27	14
7.1	50.41	50.55	50.69	50.84	50.98	51.12	51.27	51.41	51.55	51.70	14
7.2	51.84	51.98	52.13	52.27	52.42	52.56	52.71	52.85	53.00	53.14	15
7.3	53.29	53.44	53.58	53.73	53.88	54.02	54.17	54.32	54.46	54.61	15
7.4	54.76	54.91	55.06	55.20	55.35	55.50	55.65	55.80	55.95	56.10	15
7.5	56.25	56.40	56.55	56.70	56.85	57.00	57.15	57.30	57.46	57.61	15
7.6	57.76	57.91	58.06	58.22	58.37	58.52	58.68	58.83	58.98	59.14	15
7.7	59.29	59.44	59.60	59.75	59.91	60.06	60.22	60.37	60.53	60.68	16
7.8	60.84	61.00	61.15	61.31	61.47	61.62	61.78	61.94	62.09	62.25	16
7.9	62.41	62.57	62.73	62.88	63.04	63.20	63.36	63.52	63.68	63.84	16
8.0	64.00	64.16	64.32	64.48	64.64	64.80	64.96	65.12	65.29	65.45	16
8.1	65.61	65.77	65.93	66.10	66.26	66.42	66.59	66.75	66.91	67.08	16
8.2	67.24	67.40	67.57	67.73	67.90	68.06	68.23	68.39	68.56	68.72	17
8.3	68.89	69.06	69.22	69.39	69.56	69.72	69.89	70.06	70.22	70.39	17
8.4	70.56	70.73	70.90	71.06	71.23	71.40	71.57	71.74	71.91	72.08	17
8.5	72.25	72.42	72.59	72.76	72.93	73.10	73.27	73.44	73.62	73.79	17
8.6	73.96	74.13	74.30	74.48	74.65	74.82	75.00	75.17	75.34	75.52	17
8.7	75.69	75.86	76.04	76.21	76.39	76.56	76.74	76.91	77.09	77.26	18
8.8	77.44	77.62	77.79	77.97	78.15	78.32	78.50	78.68	78.85	79.03	18
8.9	79.21	79.39	79.57	79.74	79.92	80.10	80.28	80.46	80.64	80.82	18
9.0	81.00	81.18	81.36	81.54	81.72	81.90	82.08	82.26	82.45	82.63	18
9.1	82.81	82.99	83.17	83.36	83.54	83.72	83.91	84.09	84.27	84.46	18
9.2	84.64	84.82	85.01	85.19	85.38	85.56	85.75	85.93	86.12	86.30	19
9.3	86.49	86.68	86.86	87.05	87.24	87.42	87.61	87.80	87.98	88.17	19
9.4	88.36	88.55	88.74	88.92	89.11	89.30	89.49	89.68	89.87	90.06	19
9.5	90.25	90.44	90.63	90.82	91.01	91.20	91.39	91.58	91.78	91.97	19
9.6	92.16	92.35	92.54	92.74	92.93	93.12	93.32	93.51	93.70	93.90	19
9.7	94.09	94.28	94.48	94.67	94.87	95.06	95.26	95.45	95.65	95.84	20
9.8	96.04	96.24	96.43	96.63	96.83	97.02	97.22	97.42	97.61	97.81	20
9.9	98.01	98.21	98.41	98.60	98.80	99.00	99.20	99.40	99.60	99.80	20
<i>n</i>	0	1	2	3	4	5	6	7	8	9	Diff.

TABLE XVII.—LOGARITHMS; 1000 TO 1409.

	0	1	2	3	4	5	6	7	8	9
100	0000	0004	0009	0013	0017	0022	0026	0030	0035	0039
101	0043	0048	0052	0056	0060	0065	0069	0073	0077	0082
102	0086	0090	0095	0099	0103	0107	0111	0116	0120	0124
103	0128	0133	0137	0141	0145	0149	0154	0158	0162	0166
104	0170	0175	0179	0183	0187	0191	0195	0199	0204	0208
105	0212	0216	0220	0224	0228	0233	0237	0241	0245	0249
106	0253	0257	0261	0265	0269	0273	0278	0282	0286	0290
107	0294	0298	0302	0306	0310	0314	0318	0322	0326	0330
108	0334	0338	0342	0346	0350	0354	0358	0362	0366	0370
109	0374	0378	0382	0386	0390	0394	0398	0402	0406	0410
110	0414	0418	0422	0426	0430	0434	0438	0441	0445	0449
111	0453	0457	0461	0465	0469	0473	0477	0481	0484	0488
112	0492	0496	0500	0504	0508	0512	0515	0519	0523	0527
113	0531	0535	0538	0542	0546	0550	0554	0558	0561	0565
114	0569	0573	0577	0580	0584	0588	0592	0596	0599	0603
115	0607	0611	0615	0618	0622	0626	0630	0633	0637	0641
116	0645	0648	0652	0656	0660	0663	0667	0671	0674	0678
117	0682	0686	0689	0693	0697	0700	0704	0708	0711	0715
118	0719	0722	0726	0730	0734	0737	0741	0745	0748	0752
119	0755	0759	0763	0766	0770	0774	0777	0781	0785	0788
120	0792	0795	0799	0803	0806	0810	0813	0817	0821	0824
121	0828	0831	0835	0839	0842	0846	0849	0853	0856	0860
122	0864	0867	0871	0874	0878	0881	0885	0888	0892	0896
123	0899	0903	0906	0910	0913	0917	0920	0924	0927	0931
124	0934	0938	0941	0945	0948	0952	0955	0959	0962	0966
125	0969	0973	0976	0980	0983	0986	0990	0993	0997	1000
126	1004	1007	1011	1014	1017	1021	1024	1028	1031	1035
127	1038	1041	1045	1048	1052	1055	1059	1062	1065	1069
128	1072	1075	1079	1082	1086	1089	1092	1096	1099	1103
129	1106	1109	1113	1116	1119	1123	1126	1129	1133	1136
130	1139	1143	1146	1149	1153	1156	1159	1163	1166	1169
131	1173	1176	1179	1183	1186	1189	1193	1196	1199	1202
132	1206	1209	1212	1216	1219	1222	1225	1229	1232	1235
133	1239	1242	1245	1248	1252	1255	1258	1261	1265	1268
134	1271	1274	1278	1281	1284	1287	1290	1294	1297	1300
135	1303	1307	1310	1313	1316	1319	1323	1326	1329	1332
136	1335	1339	1342	1345	1348	1351	1355	1358	1361	1364
137	1367	1370	1374	1377	1380	1383	1386	1389	1392	1396
138	1399	1402	1405	1408	1411	1414	1418	1421	1424	1427
139	1430	1433	1436	1440	1443	1446	1449	1452	1455	1458
140	1461	1464	1467	1471	1474	1477	1480	1483	1486	1489

(Bottomley, "Four Fig. Math. Tables.")

* TABLE XVIII. — LOGARITHMS.

	0	1	2	3	4	5	6	7	8	9	1	2	3	4	5	6	7	8	9
10	0000	0043	0086	0128	0170	0212	0253	0294	0334	0374	4	8	12	17	21	25	29	33	37
11	0414	0453	0492	0531	0569	0607	0645	0682	0719	0755	4	8	11	15	19	23	26	30	34
12	0792	0828	0864	0899	0934	0969	1004	1038	1072	1106	3	7	10	14	17	21	24	28	31
13	1139	1173	1206	1239	1271	1303	1335	1367	1399	1430	3	6	10	13	16	19	23	26	29
14	1461	1492	1523	1553	1584	1614	1644	1673	1703	1732	3	6	9	12	15	18	21	24	27
15	1761	1790	1818	1847	1875	1903	1931	1959	1987	2014	3	6	8	11	14	17	20	22	25
16	2041	2068	2095	2122	2148	2175	2201	2227	2253	2279	3	5	8	11	13	16	18	21	24
17	2304	2330	2355	2380	2405	2430	2455	2480	2504	2529	2	5	7	10	12	15	17	20	22
18	2533	2577	2601	2625	2648	2672	2695	2718	2742	2765	2	5	7	9	12	14	16	19	21
19	2788	2810	2833	2856	2878	2900	2923	2945	2967	2989	2	4	7	9	11	13	16	18	20
20	3010	3032	3054	3075	3096	3118	3139	3160	3181	3201	2	4	6	8	11	13	15	17	19
21	3222	3243	3263	3284	3304	3324	3345	3365	3385	3404	2	4	6	8	10	12	14	16	18
22	3424	3444	3464	3483	3502	3522	3541	3560	3579	3598	2	4	6	8	10	12	14	15	17
23	3617	3636	3655	3674	3692	3711	3729	3747	3766	3784	2	4	6	7	9	11	13	15	17
24	3802	3820	3838	3856	3874	3892	3909	3927	3945	3962	2	4	5	7	9	11	12	14	16
25	3979	3997	4014	4031	4048	4065	4082	4099	4116	4133	2	3	5	7	9	10	12	14	15
26	4150	4166	4183	4200	4216	4232	4249	4265	4281	4298	2	3	5	7	8	10	11	13	15
27	4314	4330	4346	4362	4378	4393	4409	4425	4440	4456	2	3	5	6	8	9	11	13	14
28	4472	4487	4502	4518	4533	4548	4564	4579	4594	4609	2	3	5	6	8	9	11	12	14
29	4624	4639	4654	4669	4683	4698	4713	4728	4742	4757	1	3	4	6	7	9	10	12	13
30	4771	4786	4800	4814	4829	4843	4857	4871	4886	4900	1	3	4	6	7	9	10	11	13
31	4914	4928	4942	4955	4969	4983	4997	5011	5024	5038	1	3	4	6	7	8	10	11	12
32	5051	5065	5079	5092	5105	5119	5132	5145	5159	5172	1	3	4	5	7	8	9	11	12
33	5185	5198	5211	5224	5237	5250	5263	5276	5289	5302	1	3	4	5	6	8	9	10	12
34	5315	5328	5340	5353	5366	5378	5391	5403	5416	5428	1	3	4	5	6	8	9	10	11
35	5441	5453	5465	5478	5490	5502	5514	5527	5539	5551	1	2	4	5	6	7	9	10	11
36	5563	5575	5587	5599	5611	5623	5635	5647	5658	5670	1	2	4	5	6	7	8	10	11
37	5682	5694	5705	5717	5729	5740	5752	5763	5775	5786	1	2	3	5	6	7	8	9	10
38	5798	5809	5821	5832	5843	5855	5866	5877	5888	5899	1	2	3	5	6	7	8	9	10
39	5911	5922	5933	5944	5955	5966	5977	5988	5999	6010	1	2	3	4	5	7	8	9	10
40	6021	6031	6042	6053	6064	6075	6085	6096	6107	6117	1	2	3	4	5	6	8	9	10
41	6128	6138	6149	6160	6170	6180	6191	6201	6212	6222	1	2	3	4	5	6	7	8	9
42	6232	6243	6253	6263	6274	6284	6294	6304	6314	6325	1	2	3	4	5	6	7	8	9
43	6335	6345	6355	6365	6375	6385	6395	6405	6415	6425	1	2	3	4	5	6	7	8	9
44	6435	6444	6454	6464	6474	6484	6493	6503	6513	6522	1	2	3	4	5	6	7	8	9
45	6532	6542	6551	6561	6571	6580	6590	6599	6609	6618	1	2	3	4	5	6	7	8	9
46	6628	6637	6646	6656	6665	6675	6684	6693	6702	6712	1	2	3	4	5	6	7	7	8
47	6721	6730	6739	6749	6758	6767	6776	6785	6794	6803	1	2	3	4	5	5	6	7	8
48	6812	6821	6830	6839	6848	6857	6866	6875	6884	6893	1	2	3	4	4	5	6	7	8
49	6902	6911	6920	6928	6937	6946	6955	6964	6972	6981	1	2	3	4	4	5	6	7	8
50	6990	6998	7007	7016	7024	7033	7042	7050	7059	7067	1	2	3	3	4	5	6	7	8
51	7076	7084	7093	7101	7110	7118	7126	7135	7143	7152	1	2	3	3	4	5	6	7	8
52	7160	7168	7177	7185	7193	7202	7210	7218	7226	7235	1	2	2	3	4	5	6	7	7
53	7243	7251	7259	7267	7275	7284	7292	7300	7308	7316	1	2	2	3	4	5	6	6	7
54	7324	7332	7340	7348	7356	7364	7372	7380	7388	7396	1	2	2	3	4	5	6	6	7

* From Bottomley's Four Figure Mathematical Tables, by courtesy of The Macmillan Company.

TABLE XVIII. — LOGARITHMS (Concluded).

	0	1	2	3	4	5	6	7	8	9	1	2	3	4	5	6	7	8	9
55	7404	7412	7419	7427	7435	7443	7451	7459	7466	7474	1	2	2	3	4	5	5	6	7
56	7482	7490	7497	7505	7513	7520	7528	7536	7543	7551	1	2	2	3	4	5	5	6	7
57	7559	7566	7574	7582	7589	7597	7604	7612	7619	7627	1	2	2	3	4	5	5	6	7
58	7634	7642	7649	7657	7664	7672	7679	7686	7694	7701	1	1	2	3	4	4	5	6	7
59	7709	7716	7723	7731	7738	7745	7752	7760	7767	7774	1	1	2	3	4	4	5	6	7
60	7782	7789	7796	7803	7810	7818	7825	7832	7839	7846	1	1	2	3	4	4	5	6	6
61	7853	7860	7868	7875	7882	7889	7896	7903	7910	7917	1	1	2	3	4	4	5	6	6
62	7924	7931	7938	7945	7952	7959	7966	7973	7980	7987	1	1	2	3	3	4	5	6	6
63	7993	8000	8007	8014	8021	8028	8035	8041	8048	8055	1	1	2	3	3	4	5	5	6
64	8062	8069	8075	8082	8089	8096	8102	8109	8116	8122	1	1	2	3	3	4	5	5	6
65	8129	8136	8142	8149	8156	8162	8169	8176	8182	8189	1	1	2	3	3	4	5	5	6
66	8195	8202	8209	8215	8222	8228	8235	8241	8248	8254	1	1	2	3	3	4	5	5	6
67	8261	8267	8274	8280	8287	8293	8299	8306	8312	8319	1	1	2	3	3	4	5	5	6
68	8325	8331	8338	8344	8351	8357	8363	8370	8376	8382	1	1	2	3	3	4	4	5	6
69	8388	8395	8401	8407	8414	8420	8426	8432	8439	8445	1	1	2	2	3	4	4	5	6
70	8451	8457	8463	8470	8476	8482	8488	8494	8500	8506	1	1	2	2	3	4	4	5	6
71	8513	8519	8525	8531	8537	8543	8549	8555	8561	8567	1	1	2	2	3	4	4	5	5
72	8573	8579	8585	8591	8597	8603	8609	8615	8621	8627	1	1	2	2	3	4	4	5	5
73	8633	8639	8645	8651	8657	8663	8669	8675	8681	8686	1	1	2	2	3	4	4	5	5
74	8692	8698	8704	8710	8716	8722	8727	8733	8739	8745	1	1	2	2	3	4	4	5	5
75	8751	8756	8762	8768	8774	8779	8785	8791	8797	8802	1	1	2	2	3	3	4	5	5
76	8808	8814	8820	8825	8831	8837	8842	8848	8854	8859	1	1	2	2	3	3	4	5	5
77	8865	8871	8876	8882	8887	8893	8899	8904	8910	8915	1	1	2	2	3	3	4	4	5
78	8921	8927	8932	8938	8943	8949	8954	8960	8965	8971	1	1	2	2	3	3	4	4	5
79	8976	8982	8987	8993	8998	9004	9009	9015	9020	9025	1	1	2	2	3	3	4	4	5
80	9031	9036	9042	9047	9053	9058	9063	9069	9074	9079	1	1	2	2	3	3	4	4	5
81	9085	9090	9096	9101	9106	9112	9117	9122	9128	9133	1	1	2	2	3	3	4	4	5
82	9138	9143	9149	9154	9159	9165	9170	9175	9180	9186	1	1	2	2	3	3	4	4	5
83	9191	9196	9201	9206	9212	9217	9222	9227	9232	9238	1	1	2	2	3	3	4	4	5
84	9243	9248	9253	9258	9263	9269	9274	9279	9284	9289	1	1	2	2	3	3	4	4	5
85	9294	9299	9304	9309	9315	9320	9325	9330	9335	9340	1	1	2	2	3	3	4	4	5
86	9345	9350	9355	9360	9365	9370	9375	9380	9385	9390	1	1	2	2	3	3	4	4	5
87	9395	9400	9405	9410	9415	9420	9425	9430	9435	9440	1	1	2	2	3	3	4	4	4
88	9445	9450	9455	9460	9465	9469	9474	9479	9484	9489	1	1	2	2	3	3	4	4	4
89	9494	9499	9504	9509	9513	9518	9523	9528	9533	9538	1	1	2	2	3	3	4	4	4
90	9542	9547	9552	9557	9562	9566	9571	9576	9581	9586	1	1	2	2	3	3	4	4	4
91	9590	9595	9600	9605	9609	9614	9619	9624	9628	9633	1	1	2	2	3	3	4	4	4
92	9638	9643	9647	9652	9657	9661	9666	9671	9675	9680	1	1	2	2	3	3	4	4	4
93	9685	9689	9694	9699	9703	9708	9713	9717	9722	9727	1	1	2	2	3	3	4	4	4
94	9731	9736	9741	9745	9750	9754	9759	9763	9768	9773	1	1	2	2	3	3	4	4	4
95	9777	9782	9786	9791	9795	9800	9805	9809	9814	9818	1	1	2	2	3	3	4	4	4
96	9823	9827	9832	9836	9841	9845	9850	9854	9859	9863	1	1	2	2	3	3	4	4	4
97	9868	9872	9877	9881	9886	9890	9894	9899	9903	9908	1	1	2	2	3	3	4	4	4
98	9912	9917	9921	9926	9930	9934	9939	9943	9948	9952	1	1	2	2	3	3	4	4	4
99	9956	9961	9965	9969	9974	9978	9983	9987	9991	9996	1	1	2	2	3	3	4	4	4

* TABLE XIX.—NATURAL SINES.

	0'	6'	12'	18'	24'	30'	36'	42'	48'	54'	1	2	3	4	5
0°	0000	0017	0035	0052	0070	0087	0105	0122	0140	0157	3	6	9	12	15
1	0175	0192	0209	0227	0244	0262	0279	0297	0314	0332	3	6	9	12	15
2	0349	0366	0384	0401	0419	0436	0454	0471	0488	0506	3	6	9	12	15
3	0523	0541	0558	0576	0593	0610	0628	0645	0663	0680	3	6	9	12	15
4	0698	0715	0732	0750	0767	0785	0802	0819	0837	0854	3	6	9	12	15
5	0872	0889	0906	0924	0941	0958	0976	0993	1011	1028	3	6	9	12	14
6	1045	1063	1080	1097	1115	1132	1149	1167	1184	1201	3	6	9	12	14
7	1219	1236	1253	1271	1288	1305	1323	1340	1357	1374	3	6	9	12	14
8	1392	1409	1426	1444	1461	1478	1495	1513	1530	1547	3	6	9	12	14
9	1564	1582	1599	1616	1633	1650	1668	1685	1702	1719	3	6	9	12	14
10	1736	1754	1771	1788	1805	1822	1840	1857	1874	1891	3	6	9	12	14
11	1908	1925	1942	1959	1977	1994	2011	2028	2045	2062	3	6	9	11	14
12	2079	2096	2113	2130	2147	2164	2181	2198	2215	2232	3	6	9	11	14
13	2250	2267	2284	2300	2317	2334	2351	2368	2385	2402	3	6	8	11	14
14	2419	2436	2453	2470	2487	2504	2521	2538	2554	2571	3	6	8	11	14
15	2588	2605	2622	2639	2656	2672	2689	2706	2723	2740	3	6	8	11	14
16	2756	2773	2790	2807	2823	2840	2857	2874	2890	2907	3	6	8	11	14
17	2924	2940	2957	2974	2990	3007	3024	3040	3057	3074	3	6	8	11	14
18	3090	3107	3123	3140	3156	3173	3190	3206	3223	3239	3	6	8	11	14
19	3256	3272	3289	3305	3322	3338	3355	3371	3387	3404	3	5	8	11	14
20	3420	3437	3453	3469	3486	3502	3518	3535	3551	3567	3	5	8	11	14
21	3584	3600	3616	3633	3649	3665	3681	3697	3714	3730	3	5	8	11	14
22	3746	3762	3778	3795	3811	3827	3843	3859	3875	3891	3	5	8	11	14
23	3907	3923	3939	3955	3971	3987	4003	4019	4035	4051	3	5	8	11	14
24	4067	4083	4099	4115	4131	4147	4163	4179	4195	4210	3	5	8	11	13
25	4226	4242	4258	4274	4289	4305	4321	4337	4352	4368	3	5	8	11	13
26	4384	4399	4415	4431	4446	4462	4478	4493	4509	4524	3	5	8	10	13
27	4540	4555	4571	4586	4602	4617	4633	4648	4664	4679	3	5	8	10	13
28	4695	4710	4726	4741	4756	4772	4787	4802	4818	4833	3	5	8	10	13
29	4848	4863	4879	4894	4909	4924	4939	4955	4970	4985	3	5	8	10	13
30	5000	5015	5030	5045	5060	5075	5090	5105	5120	5135	3	5	8	10	13
31	5150	5165	5180	5195	5210	5225	5240	5255	5270	5284	2	5	7	10	12
32	5299	5314	5329	5344	5358	5373	5388	5402	5417	5432	2	5	7	10	12
33	5446	5461	5476	5490	5505	5519	5534	5548	5563	5577	2	5	7	10	12
34	5592	5606	5621	5635	5650	5664	5678	5693	5707	5721	2	5	7	10	12
35	5736	5750	5764	5779	5793	5807	5821	5835	5850	5864	2	5	7	10	12
36	5878	5892	5906	5920	5934	5948	5962	5976	5990	6004	2	5	7	9	12
37	6018	6032	6046	6060	6074	6088	6101	6115	6129	6143	2	5	7	9	12
38	6157	6170	6184	6198	6211	6225	6239	6252	6266	6280	2	5	7	9	11
39	6293	6307	6320	6334	6347	6361	6374	6388	6401	6414	2	4	7	9	11
40	6428	6441	6455	6468	6481	6494	6508	6521	6534	6547	2	4	7	9	11
41	6561	6574	6587	6600	6613	6626	6639	6652	6665	6678	2	4	7	9	11
42	6691	6704	6717	6730	6743	6756	6769	6782	6794	6807	2	4	6	9	11
43	6820	6833	6845	6858	6871	6884	6896	6909	6921	6934	2	4	6	8	11
44	6947	6959	6972	6984	6997	7009	7022	7034	7046	7059	2	4	6	8	10

* From Bottomley's Four Figure Mathematical Tables, by courtesy of The Macmillan Company.

TABLE XIX. — NATURAL SINES (Concluded).

	0'	6'	12'	18'	24'	30'	36'	42'	48'	54'	1	2	3	4	5
45°	7071	7083	7096	7108	7120	7133	7145	7157	7169	7181	2	4	6	8	10
46	7193	7206	7218	7230	7242	7254	7266	7278	7290	7302	2	4	6	8	10
47	7314	7325	7337	7349	7361	7373	7385	7396	7408	7420	2	4	6	8	10
48	7431	7443	7455	7466	7478	7490	7501	7513	7524	7536	2	4	6	8	10
49	7547	7558	7570	7581	7593	7604	7615	7627	7638	7649	2	4	6	8	9
50	7660	7672	7683	7694	7705	7716	7727	7738	7749	7760	2	4	6	7	9
51	7771	7782	7793	7804	7815	7826	7837	7848	7859	7869	2	4	5	7	9
52	7880	7891	7902	7912	7923	7934	7944	7955	7965	7976	2	4	5	7	9
53	7986	7997	8007	8018	8028	8039	8049	8059	8070	8080	2	3	5	7	9
54	8090	8100	8111	8121	8131	8141	8151	8161	8171	8181	2	3	5	7	8
55	8192	8202	8211	8221	8231	8241	8251	8261	8271	8281	2	3	5	7	8
56	8290	8300	8310	8320	8329	8339	8348	8358	8368	8377	2	3	5	6	8
57	8387	8396	8406	8415	8425	8434	8443	8453	8462	8471	2	3	5	6	8
58	8480	8490	8499	8508	8517	8526	8536	8545	8554	8563	2	3	5	6	8
59	8572	8581	8590	8599	8607	8616	8625	8634	8643	8652	1	3	4	6	7
60	8660	8669	8678	8686	8695	8704	8712	8721	8729	8738	1	3	4	6	7
61	8746	8755	8763	8771	8780	8788	8796	8805	8813	8821	1	3	4	6	7
62	8829	8838	8846	8854	8862	8870	8878	8886	8894	8902	1	3	4	5	7
63	8910	8918	8926	8934	8942	8949	8957	8965	8973	8980	1	3	4	5	6
64	8988	8996	9003	9011	9018	9026	9033	9041	9048	9056	1	3	4	5	6
65	9063	9070	9078	9085	9092	9100	9107	9114	9121	9128	1	2	4	5	6
66	9135	9143	9150	9157	9164	9171	9178	9184	9191	9198	1	2	3	5	6
67	9205	9212	9219	9225	9232	9239	9245	9252	9259	9265	1	2	3	4	6
68	9272	9278	9285	9291	9298	9304	9311	9317	9323	9330	1	2	3	4	5
69	9336	9342	9348	9354	9361	9367	9373	9379	9385	9391	1	2	3	4	5
70	9397	9403	9409	9415	9421	9426	9432	9438	9444	9449	1	2	3	4	5
71	9455	9461	9466	9472	9478	9483	9489	9494	9500	9505	1	2	3	4	5
72	9511	9516	9521	9527	9532	9537	9542	9548	9553	9558	1	2	3	4	4
73	9563	9568	9573	9578	9583	9588	9593	9598	9603	9608	1	2	2	3	4
74	9613	9617	9622	9627	9632	9636	9641	9646	9650	9655	1	2	2	3	4
75	9659	9664	9668	9673	9677	9681	9686	9690	9694	9699	1	1	2	3	4
76	9703	9707	9711	9715	9720	9724	9728	9732	9736	9740	1	1	2	3	3
77	9744	9748	9751	9755	9759	9763	9767	9770	9774	9778	1	1	2	3	3
78	9781	9785	9789	9792	9796	9799	9803	9806	9810	9813	1	1	2	2	3
79	9816	9820	9823	9826	9829	9833	9836	9839	9842	9845	1	1	2	2	3
80	9848	9851	9854	9857	9860	9863	9866	9869	9871	9874	0	1	1	2	2
81	9877	9880	9882	9885	9888	9890	9893	9895	9898	9900	0	1	1	2	2
82	9903	9905	9907	9910	9912	9914	9917	9919	9921	9923	0	1	1	2	2
83	9925	9928	9930	9932	9934	9936	9938	9940	9942	9943	0	1	1	1	2
84	9945	9947	9949	9951	9952	9954	9956	9957	9959	9960	0	1	1	1	1
85	9962	9963	9965	9966	9968	9969	9971	9972	9973	9974	0	0	1	1	1
86	9976	9977	9978	9979	9980	9981	9982	9983	9984	9985	0	0	1	1	1
87	9986	9987	9988	9989	9990	9990	9991	9992	9993	9993	0	0	0	1	1
88	9994	9995	9995	9996	9996	9997	9997	9997	9998	9998	0	0	0	0	0
89	9998	9999	9999	9999	9999	1'000 nearly.	1'000 nearly.	1'000 nearly.	1'000 nearly.	1'000 nearly.	0	0	0	0	0

* TABLE XX. — NATURAL COSINES.

	0'	6'	12'	18'	24'	30'	36'	42'	48'	54'	1	2	3	4	5
0°	1'000	1'000	1'000	1'000	1'000	9999	9999	9999	9999	9999	0	0	0	0	0
	nearly.	nearly.	nearly.	nearly.	nearly.	nearly.	nearly.	nearly.	nearly.	nearly.					
1	9998	9998	9998	9997	9997	9997	9996	9996	9995	9995	0	0	0	0	0
2	9994	9993	9993	9992	9991	9990	9990	9989	9988	9987	0	0	0	1	1
3	9986	9985	9984	9983	9982	9981	9980	9979	9978	9977	0	0	1	1	1
4	9976	9974	9973	9972	9971	9969	9968	9966	9965	9963	0	0	1	1	1
5	9962	9960	9959	9957	9956	9954	9952	9951	9949	9947	0	1	1	1	2
6	9945	9943	9942	9940	9938	9936	9934	9932	9930	9928	0	1	1	1	2
7	9925	9923	9921	9919	9917	9914	9912	9910	9907	9905	0	1	1	2	2
8	9903	9900	9898	9895	9893	9890	9888	9885	9882	9880	0	1	1	2	2
9	9877	9874	9871	9869	9866	9863	9860	9857	9854	9851	0	1	1	2	2
10	9848	9845	9842	9839	9836	9833	9829	9826	9823	9820	1	1	2	2	3
11	9816	9813	9810	9806	9803	9799	9796	9792	9789	9785	1	1	2	2	3
12	9781	9778	9774	9770	9767	9763	9759	9755	9751	9748	1	1	2	3	3
13	9744	9740	9736	9732	9728	9724	9720	9715	9711	9707	1	1	2	3	3
14	9703	9699	9694	9690	9686	9681	9677	9673	9668	9664	1	1	2	3	4
15	9659	9655	9650	9646	9641	9636	9632	9627	9622	9617	1	2	2	3	4
16	9613	9608	9603	9598	9593	9588	9583	9578	9573	9568	1	2	2	3	4
17	9563	9558	9553	9548	9542	9537	9532	9527	9521	9516	1	2	3	4	4
18	9511	9505	9500	9494	9489	9483	9478	9472	9466	9461	1	2	3	4	5
19	9455	9449	9444	9438	9432	9426	9421	9415	9409	9403	1	2	3	4	5
20	9397	9391	9385	9379	9373	9367	9361	9354	9348	9342	1	2	3	4	5
21	9336	9330	9323	9317	9311	9304	9298	9291	9285	9278	1	2	3	4	5
22	9272	9265	9259	9252	9245	9239	9232	9225	9219	9212	1	2	3	4	6
23	9205	9198	9191	9184	9178	9171	9164	9157	9150	9143	1	2	3	5	6
24	9135	9128	9121	9114	9107	9100	9092	9085	9078	9070	1	2	4	5	6
25	9063	9056	9048	9041	9033	9026	9018	9011	9003	8996	1	3	4	5	6
26	8988	8980	8973	8965	8957	8949	8942	8934	8926	8918	1	3	4	5	6
27	8910	8902	8894	8886	8878	8870	8862	8854	8846	8838	1	3	4	5	7
28	8829	8821	8813	8805	8796	8788	8780	8771	8763	8755	1	3	4	6	7
29	8746	8738	8729	8721	8712	8704	8695	8686	8678	8669	1	3	4	6	7
30	8660	8652	8643	8634	8625	8616	8607	8599	8590	8581	1	3	4	6	7
31	8572	8563	8554	8545	8536	8526	8517	8508	8499	8490	2	3	5	6	8
32	8480	8471	8462	8453	8443	8434	8425	8415	8406	8396	2	3	5	6	8
33	8387	8377	8368	8358	8348	8339	8329	8320	8310	8300	2	3	5	6	8
34	8290	8281	8271	8261	8251	8241	8231	8221	8211	8202	2	3	5	7	8
35	8192	8181	8171	8161	8151	8141	8131	8121	8111	8100	2	3	5	7	8
36	8090	8080	8070	8059	8049	8039	8028	8018	8007	7997	2	3	5	7	9
37	7986	7976	7965	7955	7944	7934	7923	7912	7902	7891	2	4	5	7	9
38	7880	7869	7859	7848	7837	7826	7815	7804	7793	7782	2	4	5	7	9
39	7771	7760	7749	7738	7727	7716	7705	7694	7683	7672	2	4	6	7	9
40	7660	7649	7638	7627	7615	7604	7593	7581	7570	7559	2	4	6	8	9
41	7547	7536	7524	7513	7501	7490	7478	7466	7455	7443	2	4	6	8	10
42	7431	7420	7408	7396	7385	7373	7361	7349	7337	7325	2	4	6	8	10
43	7314	7302	7290	7278	7266	7254	7242	7230	7218	7206	2	4	6	8	10
44	7193	7181	7169	7157	7145	7133	7120	7108	7096	7083	2	4	6	8	10

N.B. — Numbers in difference-columns to be subtracted, not added.

* From Bottomley's Four Figure Mathematical Tables, by courtesy of The Macmillan Company.

TABLE XX. — NATURAL COSINES (Concluded).

	0'	6'	12'	18'	24'	30'	36'	42'	48'	54'	1	2	3	4	5
45°	7071	7059	7046	7034	7022	7009	6997	6984	6972	6959	2	4	6	8	10
46	6947	6934	6921	6909	6896	6884	6871	6858	6845	6833	2	4	6	8	11
47	6820	6807	6794	6782	6769	6756	6743	6730	6717	6704	2	4	6	9	11
48	6691	6678	6665	6652	6639	6626	6613	6600	6587	6574	2	4	7	9	11
49	6561	6547	6534	6521	6508	6494	6481	6468	6455	6441	2	4	7	9	11
50	6428	6414	6401	6388	6374	6361	6347	6334	6320	6307	2	4	7	9	11
51	6293	6280	6266	6252	6239	6225	6211	6198	6184	6170	2	5	7	9	11
52	6157	6143	6129	6115	6101	6088	6074	6060	6046	6032	2	5	7	9	12
53	6018	6004	5990	5976	5962	5948	5934	5920	5906	5892	2	5	7	9	12
54	5878	5864	5850	5835	5821	5807	5793	5779	5764	5750	2	5	7	9	12
55	5736	5721	5707	5693	5678	5664	5650	5635	5621	5606	2	5	7	10	12
56	5592	5577	5563	5548	5534	5519	5505	5490	5476	5461	2	5	7	10	12
57	5446	5432	5417	5402	5388	5373	5358	5344	5329	5314	2	5	7	10	12
58	5299	5284	5270	5255	5240	5225	5210	5195	5180	5165	2	5	7	10	12
59	5150	5135	5120	5105	5090	5075	5060	5045	5030	5015	3	5	8	10	13
60	5000	4985	4970	4955	4939	4924	4909	4894	4879	4863	3	5	8	10	13
61	4848	4833	4818	4802	4787	4772	4756	4741	4726	4710	3	5	8	10	13
62	4695	4679	4664	4648	4633	4617	4602	4586	4571	4555	3	5	8	10	13
63	4540	4524	4509	4493	4478	4462	4446	4431	4415	4399	3	5	8	10	13
64	4384	4368	4352	4337	4321	4305	4289	4274	4258	4242	3	5	8	11	13
65	4226	4210	4195	4179	4163	4147	4131	4115	4099	4083	3	5	8	11	13
66	4067	4051	4035	4019	4003	3987	3971	3955	3939	3923	3	5	8	11	14
67	3907	3891	3875	3859	3843	3827	3811	3795	3778	3762	3	5	8	11	14
68	3746	3730	3714	3697	3681	3665	3649	3633	3616	3600	3	5	8	11	14
69	3584	3567	3551	3535	3518	3502	3486	3469	3453	3437	3	5	8	11	14
70	3420	3404	3387	3371	3355	3338	3322	3305	3289	3272	3	5	8	11	14
71	3256	3239	3223	3206	3190	3173	3156	3140	3123	3107	3	6	8	11	14
72	3090	3074	3057	3040	3024	3007	2990	2974	2957	2940	3	6	8	11	14
73	2924	2907	2890	2874	2857	2840	2823	2807	2790	2773	3	6	8	11	14
74	2756	2740	2723	2706	2689	2672	2656	2639	2622	2605	3	6	8	11	14
75	2588	2571	2554	2538	2521	2504	2487	2470	2453	2436	3	6	8	11	14
76	2419	2402	2385	2368	2351	2334	2317	2300	2284	2267	3	6	8	11	14
77	2250	2233	2215	2198	2181	2164	2147	2130	2113	2096	3	6	9	11	14
78	2079	2062	2045	2028	2011	1994	1977	1959	1942	1925	3	6	9	11	14
79	1908	1891	1874	1857	1840	1822	1805	1788	1771	1754	3	6	9	12	14
80	1736	1719	1702	1685	1668	1650	1633	1616	1599	1582	3	6	9	12	14
81	1564	1547	1530	1513	1495	1478	1461	1444	1426	1409	3	6	9	12	14
82	1392	1374	1357	1340	1323	1305	1288	1271	1253	1236	3	6	9	12	14
83	1219	1201	1184	1167	1149	1132	1115	1097	1080	1063	3	6	9	12	14
84	1045	1028	1011	0993	0976	0958	0941	0924	0906	0889	3	6	9	12	14
85	0872	0854	0837	0819	0802	0785	0767	0750	0732	0715	3	6	9	12	15
86	0698	0680	0663	0645	0628	0610	0593	0576	0558	0541	3	6	9	12	15
87	0523	0506	0488	0471	0454	0436	0419	0401	0384	0366	3	6	9	12	15
88	0349	0332	0314	0297	0279	0262	0244	0227	0209	0192	3	6	9	12	15
89	0175	0157	0140	0122	0105	0087	0070	0052	0035	0017	3	6	9	12	15

N.B. — Numbers in difference-columns to be subtracted, not added.

* TABLE XXI.—NATURAL TANGENTS.

	0'	6'	12'	18'	24'	30'	36'	42'	48'	54'	1	2	3	4	5
0°	·0000	0017	0035	0052	0070	0087	0105	0122	0140	0157	3	6	9	12	14
1	·0175	0192	0209	0227	0244	0262	0279	0297	0314	0332	3	6	9	12	15
2	·0349	0367	0384	0402	0419	0437	0454	0472	0489	0507	3	6	9	12	15
3	·0524	0542	0559	0577	0594	0612	0629	0647	0664	0682	3	6	9	12	15
4	·0699	0717	0734	0752	0769	0787	0805	0822	0840	0857	3	6	9	12	15
5	·0875	0892	0910	0928	0945	0963	0981	0998	1016	1033	3	6	9	12	15
6	·1051	1069	1086	1104	1122	1139	1157	1175	1192	1210	3	6	9	12	15
7	·1228	1246	1263	1281	1299	1317	1334	1352	1370	1388	3	6	9	12	15
8	·1405	1423	1441	1459	1477	1495	1512	1530	1548	1566	3	6	9	12	15
9	·1584	1602	1620	1638	1655	1673	1691	1709	1727	1745	3	6	9	12	15
10	·1763	1781	1799	1817	1835	1853	1871	1890	1908	1926	3	6	9	12	15
11	·1944	1962	1980	1998	2016	2035	2053	2071	2089	2107	3	6	9	12	15
12	·2126	2144	2162	2180	2199	2217	2235	2254	2272	2290	3	6	9	12	15
13	·2309	2327	2345	2364	2382	2401	2419	2438	2456	2475	3	6	9	12	15
14	·2493	2512	2530	2549	2568	2586	2605	2623	2642	2661	3	6	9	12	16
15	·2679	2698	2717	2736	2754	2773	2792	2811	2830	2849	3	6	9	13	16
16	·2867	2886	2905	2924	2943	2962	2981	3000	3019	3038	3	6	9	13	16
17	·3057	3076	3096	3115	3134	3153	3172	3191	3211	3230	3	6	10	13	16
18	·3249	3269	3288	3307	3327	3346	3365	3385	3404	3424	3	6	10	13	16
19	·3443	3463	3482	3502	3522	3541	3561	3581	3600	3620	3	6	10	13	17
20	·3640	3659	3679	3699	3719	3739	3759	3779	3799	3819	3	7	10	13	17
21	·3839	3859	3879	3899	3919	3939	3959	3979	4000	4020	3	7	10	13	17
22	·4040	4061	4081	4101	4122	4142	4163	4183	4204	4224	3	7	10	14	17
23	·4245	4265	4286	4307	4327	4348	4369	4390	4411	4431	3	7	10	14	17
24	·4452	4473	4494	4515	4536	4557	4578	4599	4621	4642	4	7	10	14	18
25	·4663	4684	4706	4727	4748	4770	4791	4813	4834	4856	4	7	11	14	18
26	·4877	4899	4921	4942	4964	4986	5008	5029	5051	5073	4	7	11	15	18
27	·5095	5117	5139	5161	5184	5206	5228	5250	5272	5295	4	7	11	15	18
28	·5317	5340	5362	5384	5407	5430	5452	5475	5498	5520	4	8	11	15	19
29	·5543	5566	5589	5612	5635	5658	5681	5704	5727	5750	4	8	12	15	19
30	·5774	5797	5820	5844	5867	5890	5914	5938	5961	5985	4	8	12	16	20
31	·6009	6032	6056	6080	6104	6128	6152	6176	6200	6224	4	8	12	16	20
32	·6249	6273	6297	6322	6346	6371	6395	6420	6445	6469	4	8	12	16	20
33	·6494	6519	6544	6569	6594	6619	6644	6669	6694	6720	4	8	13	17	21
34	·6745	6771	6796	6822	6847	6873	6899	6924	6950	6976	4	9	13	17	21
35	·7002	7028	7054	7080	7107	7133	7159	7186	7212	7239	4	9	13	18	22
36	·7265	7292	7319	7346	7373	7400	7427	7454	7481	7508	5	9	14	18	23
37	·7536	7563	7590	7618	7646	7673	7701	7729	7757	7785	5	9	14	18	23
38	·7813	7841	7869	7898	7926	7954	7983	8012	8040	8069	5	10	14	19	24
39	·8098	8127	8156	8185	8214	8243	8273	8302	8332	8361	5	10	15	20	24
40	·8391	8421	8451	8481	8511	8541	8571	8601	8632	8662	5	10	15	20	25
41	·8693	8724	8754	8785	8816	8847	8878	8910	8941	8972	5	10	16	21	26
42	·9004	9036	9067	9099	9131	9163	9195	9228	9260	9293	5	11	16	21	27
43	·9325	9358	9391	9424	9457	9490	9523	9556	9590	9623	6	11	17	22	28
44	·9657	9691	9725	9759	9793	9827	9861	9896	9930	9965	6	11	17	23	29

* From Bottomley's Four Figure Mathematical Tables, by courtesy of The Macmillan Company.

TABLE XXI.—NATURAL TANGENTS (Concluded).

	0'	6'	12'	18'	24'	30'	36'	42'	48'	54'	1	2	3	4	5
45°	1'0000	0035	0070	0105	0141	0176	0212	0247	0283	0319	6	12	18	24	30
46	1'0355	0392	0428	0464	0501	0538	0575	0612	0649	0686	6	12	18	25	31
47	1'0724	0761	0799	0837	0875	0913	0951	0990	1028	1067	6	13	19	25	32
48	1'1106	1145	1184	1224	1263	1303	1343	1383	1423	1463	7	13	20	26	33
49	1'1504	1544	1585	1626	1667	1708	1750	1792	1833	1875	7	14	21	28	34
50	1'1918	1960	2002	2045	2088	2131	2174	2218	2261	2305	7	14	22	29	36
51	1'2349	2393	2437	2482	2527	2572	2617	2662	2708	2753	8	15	23	30	38
52	1'2799	2846	2892	2938	2985	3032	3079	3127	3175	3222	8	16	23	31	39
53	1'3270	3319	3367	3416	3465	3514	3564	3613	3663	3713	8	16	25	33	41
54	1'3764	3814	3865	3916	3968	4019	4071	4124	4176	4229	9	17	26	34	43
55	1'4281	4335	4388	4442	4496	4550	4605	4659	4715	4770	9	18	27	36	45
56	1'4826	4882	4938	4994	5051	5108	5166	5224	5282	5340	10	19	29	38	48
57	1'5399	5458	5517	5577	5637	5697	5757	5818	5880	5941	10	20	30	40	50
58	1'6003	6066	6128	6191	6255	6319	6383	6447	6512	6577	11	21	32	43	53
59	1'6643	6709	6775	6842	6909	6977	7045	7113	7182	7251	11	23	34	45	56
60	1'7321	7391	7461	7532	7603	7675	7747	7820	7893	7966	12	24	36	48	60
61	1'8040	8115	8190	8265	8341	8418	8495	8572	8650	8728	13	26	38	51	64
62	1'8807	8887	8967	9047	9128	9210	9292	9375	9458	9542	14	27	41	55	68
63	1'9626	9711	9797	9883	9970	0057	0145	0233	0323	0413	15	29	44	58	73
64	2'0503	0594	0686	0778	0872	0965	1060	1155	1251	1348	16	31	47	63	78
65	2'1445	1543	1642	1742	1842	1943	2045	2148	2251	2355	17	34	51	68	85
66	2'2460	2566	2673	2781	2889	2998	3109	3220	3332	3445	18	37	55	74	92
67	2'3559	3673	3789	3906	4023	4142	4262	4383	4504	4627	20	40	60	79	99
68	2'4751	4876	5002	5129	5257	5386	5517	5649	5782	5916	22	43	65	87	108
69	2'6051	6187	6325	6464	6605	6746	6889	7034	7179	7326	24	47	71	95	118
70	2'7475	7625	7776	7929	8083	8239	8397	8556	8716	8878	26	52	78	104	130
71	2'9042	9208	9375	9544	9714	9887	0061	0237	0415	0595	29	58	87	115	144
72	3'0777	0961	1146	1334	1524	1716	1910	2106	2305	2506	32	64	96	129	161
73	3'2709	2914	3122	3332	3544	3759	3977	4197	4420	4646	36	72	108	144	180
74	3'4874	5105	5339	5576	5816	6059	6305	6554	6806	7062	41	82	122	162	203
75	3'7321	7583	7848	8118	8391	8667	8947	9232	9520	9812	46	94	139	186	232
76	4'0108	0408	0713	1022	1335	1653	1976	2303	2635	2972	53	107	160	214	267
77	4'3315	3662	4015	4374	4737	5107	5483	5864	6252	6646	62	124	186	248	310
78	4'7046	7453	7867	8288	8716	9152	9594	0045	0504	0970	73	146	219	292	365
79	5'1446	1929	2422	2924	3435	3955	4486	5026	5578	6140	87	175	262	350	437
80	5'6713	7297	7894	8502	9124	9758	0405	1066	1742	2432	Difference-columns cease to be useful, owing to the rapidity with which the value of the tangent changes.				
81	6'3138	3859	4596	5350	6122	6912	7920	8548	9395	0264					
82	7'1154	2066	3002	3962	4947	5958	6996	8062	9158	0285					
83	8'1443	2636	3863	5126	6427	7769	9152	0579	2052	3572					
84	9'5144	9'677	9'845	10'02	10'20	10'39	10'58	10'78	10'99	11'20					
85	11'43	11'66	11'91	12'16	12'43	12'71	13'00	13'30	13'62	13'95					
86	14'30	14'67	15'06	15'46	15'89	16'35	16'83	17'34	17'89	18'46					
87	19'08	19'74	20'45	21'20	22'02	22'90	23'86	24'90	26'03	27'27					
88	28'64	30'14	31'82	33'69	35'80	38'19	40'92	44'07	47'74	52'08					
89	57'29	63'66	71'62	81'85	95'49	114'6	143'2	191'0	286'5	573'0					

* TABLE XXII.—NATURAL COTANGENTS.

	0'	6'	12'	18'	24'	30'	36'	42'	48'	54'					
0°	Inf.	573°0	286°5	191°0	143°2	114°6	95°49	81°85	71°62	63°66					
1	57°29	52°08	47°74	44°07	40°92	38°19	35°80	33°69	31°82	30°14					
2	28°64	27°27	26°03	24°90	23°86	22°90	22°02	21°20	20°45	19°74					
3	19°08	18°46	17°89	17°34	16°83	16°35	15°89	15°46	15°06	14°67					
4	14°30	13°95	13°62	13°30	13°00	12°71	12°43	12°16	11°91	11°66					
5	11°43	11°20	10°99	10°78	10°58	10°39	10°20	10°02	9°845	9°677					
6	9°5144	3572	2052	0579	9152	7769	6427	5126	3863	2636					
7	8°1443	0285	9158	8062	6996	5958	4947	3962	3002	2066					
8	7°1154	0264	9395	8548	7920	6912	6122	5350	4596	3859					
9	6°3138	2432	1742	1066	0405	9758	9124	8502	7894	7297					
10	5°6713	6140	5578	5026	4486	3955	3435	2924	2422	1929	1	2	3	4	5
11	5°1446	0970	0504	0045	9594	9152	8716	8288	7867	7453	74	148	222	296	370
12	4°7046	6646	6252	5864	5483	5107	4737	4374	4015	3662	63	125	188	252	314
13	4°3315	2972	2635	2303	1976	1653	1335	1022	0713	0408	53	107	160	214	267
14	4°0108	9812	9520	9232	8947	8667	8391	8118	7848	7583	46	93	139	186	232
15	3°7321	7062	6806	6554	6305	6059	5816	5576	5339	5105	41	82	122	163	204
16	3°4874	4646	4420	4197	3977	3759	3544	3332	3122	2914	36	72	108	144	180
17	3°2709	2506	2305	2106	1910	1716	1524	1334	1146	0961	32	64	96	129	161
18	3°0777	0595	0415	0237	0061	9887	9714	9544	9375	9208	29	58	87	115	144
19	2°9042	8878	8716	8556	8397	8239	8083	7929	7776	7625	26	52	78	104	130
20	2°7475	7326	7179	7034	6889	6746	6605	6464	6325	6187	24	47	71	95	118
21	2°6051	5916	5782	5649	5517	5386	5257	5129	5002	4876	22	43	65	87	108
22	2°4751	4627	4504	4383	4262	4142	4023	3906	3789	3673	20	40	60	79	99
23	2°3559	3445	3332	3220	3109	2998	2889	2781	2673	2566	18	37	55	74	92
24	2°2460	2355	2251	2148	2045	1943	1842	1742	1642	1543	17	34	51	68	85
25	2°1445	1348	1251	1155	1060	0965	0872	0778	0686	0594	16	31	47	63	78
26	2°0503	0413	0323	0233	0145	0057	9970	9883	9797	9711	15	29	44	58	73
27	1°9626	9542	9458	9375	9292	9210	9128	9047	8967	8887	14	27	41	55	68
28	1°8807	8728	8650	8572	8495	8418	8341	8265	8190	8115	13	26	38	51	64
29	1°8040	7966	7893	7820	7747	7675	7603	7532	7461	7391	12	24	36	48	60
30	1°7321	7251	7182	7113	7045	6977	6909	6842	6775	6709	11	23	34	45	56
31	1°6643	6577	6512	6447	6383	6319	6255	6191	6128	6066	11	21	32	43	53
32	1°6003	5941	5880	5818	5757	5697	5637	5577	5517	5458	10	20	30	40	50
33	1°5399	5340	5282	5224	5166	5108	5051	4994	4938	4882	10	19	29	38	48
34	1°4826	4770	4715	4659	4605	4550	4496	4442	4388	4335	9	18	27	36	45
35	1°4281	4229	4176	4124	4071	4019	3968	3916	3865	3814	9	17	26	34	43
36	1°3764	3713	3663	3613	3564	3514	3465	3416	3367	3319	8	16	25	33	41
37	1°3270	3222	3175	3127	3079	3032	2985	2938	2892	2846	8	16	23	31	39
38	1°2799	2753	2708	2662	2617	2572	2527	2482	2437	2393	8	15	23	30	38
39	1°2349	2305	2261	2218	2174	2131	2088	2045	2002	1960	7	14	22	29	36
40	1°1918	1875	1833	1792	1750	1708	1667	1626	1585	1544	7	14	21	28	34
41	1°1504	1463	1423	1383	1343	1303	1263	1224	1184	1145	7	13	20	26	33
42	1°1106	1067	1028	0990	0951	0913	0875	0837	0799	0761	6	13	19	25	32
43	1°0724	0686	0649	0612	0575	0538	0501	0464	0428	0392	6	12	18	25	31
44	1°0355	0319	0283	0247	0212	0176	0141	0105	0070	0035	6	12	18	24	30

Difference-columns not useful here, owing to the rapidity with which the value of the cotangent changes.

N.B.—Numbers in difference-columns to be subtracted, not added.

* From Bottomley's Four Figure Mathematical Tables, by courtesy of The Macmillan Company.

TABLE XXII. — NATURAL COTANGENTS (Concluded).

	0'	6'	12	18'	24'	30'	36'	42'	48'	54'	1	2	3	4	5
45°	r°	0°9965	0°9930	0°9896	0°9861	0°9827	0°9793	0°9759	0°9725	0°9691	6	11	17	23	29
46	.9657	9623	9590	9556	9523	9490	9457	9424	9391	9358	6	11	17	22	28
47	.9325	9293	9260	9228	9195	9163	9131	9099	9067	9036	5	11	16	21	27
48	.9004	8972	8941	8910	8878	8847	8816	8785	8754	8724	5	10	16	21	26
49	.8693	8662	8632	8601	8571	8541	8511	8481	8451	8421	5	10	15	20	25
50	.8391	8361	8332	8302	8273	8243	8214	8185	8156	8127	5	10	15	20	24
51	.8098	8069	8040	8012	7983	7954	7926	7898	7869	7841	5	10	14	19	24
52	.7813	7785	7757	7729	7701	7673	7646	7618	7590	7563	5	9	14	18	23
53	.7536	7508	7481	7454	7427	7400	7373	7346	7319	7292	5	9	14	18	23
54	.7265	7239	7212	7186	7159	7133	7107	7080	7054	7028	4	9	13	18	22
55	.7002	6976	6950	6924	6899	6873	6847	6822	6796	6771	4	9	13	17	21
56	.6745	6720	6694	6669	6644	6619	6594	6569	6544	6519	4	8	13	17	21
57	.6494	6469	6445	6420	6395	6371	6346	6322	6297	6273	4	8	12	16	20
58	.6249	6224	6200	6176	6152	6128	6104	6080	6056	6032	4	8	12	16	20
59	.6009	5985	5961	5938	5914	5890	5867	5844	5820	5797	4	8	12	16	20
60	.5774	5750	5727	5704	5681	5658	5635	5612	5589	5566	4	8	12	15	19
61	.5543	5520	5498	5475	5452	5430	5407	5384	5362	5340	4	8	11	15	19
62	.5317	5295	5272	5250	5228	5206	5184	5161	5139	5117	4	7	11	15	18
63	.5095	5073	5051	5029	5008	4986	4964	4942	4921	4899	4	7	11	15	18
64	.4877	4856	4834	4813	4791	4770	4748	4727	4706	4684	4	7	11	14	18
65	.4663	4642	4621	4599	4578	4557	4536	4515	4494	4473	4	7	10	14	18
66	.4452	4431	4411	4390	4369	4348	4327	4307	4286	4265	3	7	10	14	17
67	.4245	4224	4204	4183	4163	4142	4122	4101	4081	4061	3	7	10	14	17
68	.4040	4020	4000	3979	3959	3939	3919	3899	3879	3859	3	7	10	13	17
69	.3839	3819	3799	3779	3759	3739	3719	3699	3679	3659	3	7	10	13	17
70	.3640	3620	3600	3581	3561	3541	3522	3502	3482	3463	3	6	10	13	17
71	.3443	3424	3404	3385	3365	3346	3327	3307	3288	3269	3	6	10	13	16
72	.3249	3230	3211	3191	3172	3153	3134	3115	3096	3076	3	6	10	13	16
73	.3057	3038	3019	3000	2981	2962	2943	2924	2905	2886	3	6	9	13	16
74	.2867	2849	2830	2811	2792	2773	2754	2736	2717	2698	3	6	9	13	16
75	.2679	2661	2642	2623	2605	2586	2568	2549	2530	2512	3	6	9	12	16
76	.2493	2475	2456	2438	2419	2401	2382	2364	2345	2327	3	6	9	12	15
77	.2309	2290	2272	2254	2235	2217	2199	2180	2162	2144	3	6	9	12	15
78	.2126	2107	2089	2071	2053	2035	2016	1998	1980	1962	3	6	9	12	15
79	.1944	1926	1908	1890	1871	1853	1835	1817	1799	1781	3	6	9	12	15
80	.1763	1745	1727	1709	1691	1673	1655	1638	1620	1602	3	6	9	12	15
81	.1584	1566	1548	1530	1512	1495	1477	1459	1441	1423	3	6	9	12	15
82	.1405	1388	1370	1352	1334	1317	1299	1281	1263	1246	3	6	9	12	15
83	.1228	1210	1192	1175	1157	1139	1122	1104	1086	1069	3	6	9	12	15
84	.1051	1033	1016	0998	0981	0963	0945	0928	0910	0892	3	6	9	12	15
85	.0875	0857	0840	0822	0805	0787	0769	0752	0734	0717	3	6	9	12	15
86	.0699	0682	0664	0647	0629	0612	0594	0577	0559	0542	3	6	9	12	15
87	.0524	0507	0489	0472	0454	0437	0419	0402	0384	0367	3	6	9	12	15
88	.0349	0332	0314	0297	0279	0262	0244	0227	0209	0192	3	6	9	12	15
89	.0175	0157	0140	0122	0105	0087	0070	0052	0035	0017	3	6	9	12	14

N.B. — Numbers in difference-columns to be subtracted, not added.

TABLE XXIII. — RADIAN MEASURE.

	0'	6'	12'	18'	24'	30'	36'	42'	48'	54'	1	2	3	4	5
0°	0.0000	0017	0035	0052	0070	0087	0105	0122	0140	0157	3	6	9	12	15
1	0.0175	0192	0209	0227	0244	0262	0279	0297	0314	0332	3	6	9	12	15
2	0.0349	0367	0384	0401	0419	0436	0454	0471	0489	0506	3	6	9	12	15
3	0.0524	0541	0559	0576	0593	0611	0628	0646	0663	0681	3	6	9	12	15
4	0.0698	0716	0733	0750	0768	0785	0803	0820	0838	0855	3	6	9	12	15
5	0.0873	0890	0908	0925	0942	0960	0977	0995	1012	1030	3	6	9	12	15
6	0.1047	1065	1082	1100	1117	1134	1152	1169	1187	1204	3	6	9	12	15
7	0.1222	1239	1257	1274	1292	1309	1326	1344	1361	1379	3	6	9	12	15
8	0.1396	1414	1431	1449	1466	1484	1501	1518	1536	1553	3	6	9	12	15
9	0.1571	1588	1606	1623	1641	1658	1676	1693	1710	1728	3	6	9	12	15
10	0.1745	1763	1780	1798	1815	1833	1850	1868	1885	1902	3	6	9	12	15
11	0.1920	1937	1955	1972	1990	2007	2025	2042	2059	2077	3	6	9	12	15
12	0.2094	2112	2129	2147	2164	2182	2199	2217	2234	2251	3	6	9	12	15
13	0.2269	2286	2304	2321	2339	2356	2374	2391	2409	2426	3	6	9	12	15
14	0.2443	2461	2478	2496	2513	2531	2548	2566	2583	2601	3	6	9	12	15
15	0.2618	2635	2653	2670	2688	2705	2723	2740	2758	2775	3	6	9	12	15
16	0.2793	2810	2827	2845	2862	2880	2897	2915	2932	2950	3	6	9	12	15
17	0.2967	2985	3002	3019	3037	3054	3072	3089	3107	3124	3	6	9	12	15
18	0.3142	3159	3176	3194	3211	3229	3246	3264	3281	3299	3	6	9	12	15
19	0.3316	3334	3351	3368	3386	3403	3421	3438	3456	3473	3	6	9	12	15
20	0.3491	3508	3526	3543	3560	3578	3595	3613	3630	3648	3	6	9	12	15
21	0.3665	3683	3700	3718	3735	3752	3770	3787	3805	3822	3	6	9	12	15
22	0.3840	3857	3875	3892	3910	3927	3944	3962	3979	3997	3	6	9	12	15
23	0.4014	4032	4049	4067	4084	4102	4119	4136	4154	4171	3	6	9	12	15
24	0.4189	4206	4224	4241	4259	4276	4294	4311	4328	4346	3	6	9	12	15
25	0.4363	4381	4398	4416	4433	4451	4468	4485	4503	4520	3	6	9	12	15
26	0.4538	4555	4573	4590	4608	4625	4643	4660	4677	4695	3	6	9	12	15
27	0.4712	4730	4747	4765	4782	4800	4817	4835	4852	4869	3	6	9	12	15
28	0.4887	4904	4922	4939	4957	4974	4992	5009	5027	5044	3	6	9	12	15
29	0.5061	5079	5096	5114	5131	5149	5166	5184	5201	5219	3	6	9	12	15
30	0.5236	5253	5271	5288	5306	5323	5341	5358	5376	5393	3	6	9	12	15
31	0.5411	5428	5445	5463	5480	5498	5515	5533	5550	5568	3	6	9	12	15
32	0.5585	5603	5620	5637	5655	5672	5690	5707	5725	5742	3	6	9	12	15
33	0.5760	5777	5794	5812	5829	5847	5864	5882	5899	5917	3	6	9	12	15
34	0.5934	5952	5969	5986	6004	6021	6039	6056	6074	6091	3	6	9	12	15
35	0.6109	6126	6144	6161	6178	6196	6213	6231	6248	6266	3	6	9	12	15
36	0.6283	6301	6318	6336	6353	6370	6388	6405	6423	6440	3	6	9	12	15
37	0.6458	6475	6493	6510	6528	6545	6562	6580	6597	6615	3	6	9	12	15
38	0.6632	6650	6667	6685	6702	6720	6737	6754	6772	6789	3	6	9	12	15
39	0.6807	6824	6842	6859	6877	6894	6912	6929	6946	6964	3	6	9	12	15
40	0.6981	6999	7016	7034	7051	7069	7086	7103	7121	7138	3	6	9	12	15
41	0.7156	7173	7191	7208	7226	7243	7261	7278	7295	7313	3	6	9	12	15
42	0.7330	7348	7365	7383	7400	7418	7435	7453	7470	7487	3	6	9	12	15
43	0.7505	7522	7540	7557	7575	7592	7610	7627	7645	7662	3	6	9	12	15
44	0.7679	7697	7714	7732	7749	7767	7784	7802	7819	7837	3	6	9	12	15

(Bottomley, "Four Fig. Math. Tables.")

TABLE XXIII. — RADIAN MEASURE (Concluded).

	0'	6'	12'	18'	24'	30'	36'	42'	48'	54'	1	2	3	4	5
45°	0.7854	7871	7889	7906	7924	7941	7959	7976	7994	8011	3	6	9	12	15
46	0.8029	8046	8063	8081	8098	8116	8133	8151	8168	8186	3	6	9	12	15
47	0.8203	8221	8238	8255	8273	8290	8308	8325	8343	8360	3	6	9	12	15
48	0.8378	8395	8412	8430	8447	8465	8482	8500	8517	8535	3	6	9	12	15
49	0.8552	8570	8587	8604	8622	8639	8657	8674	8692	8709	3	6	9	12	15
50	0.8727	8744	8762	8779	8796	8814	8831	8849	8866	8884	3	6	9	12	15
51	0.8901	8919	8936	8954	8971	8988	9006	9023	9041	9058	3	6	9	12	15
52	0.9076	9093	9111	9128	9146	9163	9180	9198	9215	9233	3	6	9	12	15
53	0.9250	9268	9285	9303	9320	9338	9355	9372	9390	9407	3	6	9	12	15
54	0.9425	9442	9460	9477	9495	9512	9529	9547	9564	9582	3	6	9	12	15
55	0.9599	9617	9634	9652	9669	9687	9704	9721	9739	9756	3	6	9	12	15
56	0.9774	9791	9809	9826	9844	9861	9879	9896	9913	9931	3	6	9	12	15
57	0.9948	9966	9983	0001	0018	0036	0053	0071	0088	0105	3	6	9	12	15
58	1.0123	0140	0158	0175	0193	0210	0228	0245	0263	0280	3	6	9	12	15
59	1.0297	0315	0332	0350	0367	0385	0402	0420	0437	0455	3	6	9	12	15
60	1.0472	0489	0507	0524	0542	0559	0577	0594	0612	0629	3	6	9	12	15
61	1.0647	0664	0681	0699	0716	0734	0751	0769	0786	0804	3	6	9	12	15
62	1.0821	0838	0856	0873	0891	0908	0926	0943	0961	0978	3	6	9	12	15
63	1.0996	1013	1030	1048	1065	1083	1100	1118	1135	1153	3	6	9	12	15
64	1.1170	1188	1205	1222	1240	1257	1275	1292	1310	1327	3	6	9	12	15
65	1.1345	1362	1380	1397	1414	1432	1449	1467	1484	1502	3	6	9	12	15
66	1.1519	1537	1554	1572	1589	1606	1624	1641	1659	1676	3	6	9	12	15
67	1.1694	1711	1729	1746	1764	1781	1798	1816	1833	1851	3	6	9	12	15
68	1.1868	1886	1903	1921	1938	1956	1973	1990	2008	2025	3	6	9	12	15
69	1.2043	2060	2078	2095	2113	2130	2147	2165	2182	2200	3	6	9	12	15
70	1.2217	2235	2252	2270	2287	2305	2322	2339	2357	2374	3	6	9	12	15
71	1.2392	2409	2427	2444	2462	2479	2497	2514	2531	2549	3	6	9	12	15
72	1.2566	2584	2601	2619	2636	2654	2671	2689	2706	2723	3	6	9	12	15
73	1.2741	2758	2776	2793	2811	2828	2846	2863	2881	2898	3	6	9	12	15
74	1.2915	2933	2950	2968	2985	3003	3020	3038	3055	3073	3	6	9	12	15
75	1.3090	3107	3125	3142	3160	3177	3195	3212	3230	3247	3	6	9	12	15
76	1.3265	3282	3299	3317	3334	3352	3369	3387	3404	3422	3	6	9	12	15
77	1.3439	3456	3474	3491	3509	3526	3544	3561	3579	3596	3	6	9	12	15
78	1.3614	3631	3648	3666	3683	3701	3718	3736	3753	3771	3	6	9	12	15
79	1.3788	3806	3823	3840	3858	3875	3893	3910	3928	3945	3	6	9	12	15
80	1.3963	3980	3998	4015	4032	4050	4067	4085	4102	4120	3	6	9	12	15
81	1.4137	4155	4172	4190	4207	4224	4242	4259	4277	4294	3	6	9	12	15
82	1.4312	4329	4347	4364	4382	4399	4416	4434	4451	4469	3	6	9	12	15
83	1.4486	4504	4521	4539	4556	4573	4591	4608	4626	4643	3	6	9	12	15
84	1.4661	4678	4696	4713	4731	4748	4765	4783	4800	4818	3	6	9	12	15
85	1.4835	4853	4870	4888	4905	4923	4940	4957	4975	4992	3	6	9	12	15
86	1.5010	5027	5045	5062	5080	5097	5115	5132	5149	5167	3	6	9	12	15
87	1.5184	5202	5219	5237	5254	5272	5289	5307	5324	5341	3	6	9	12	15
88	1.5359	5376	5394	5411	5429	5446	5464	5481	5499	5516	3	6	9	12	15
89	1.5533	5551	5568	5586	5603	5621	5638	5656	5673	5691	3	6	9	12	15

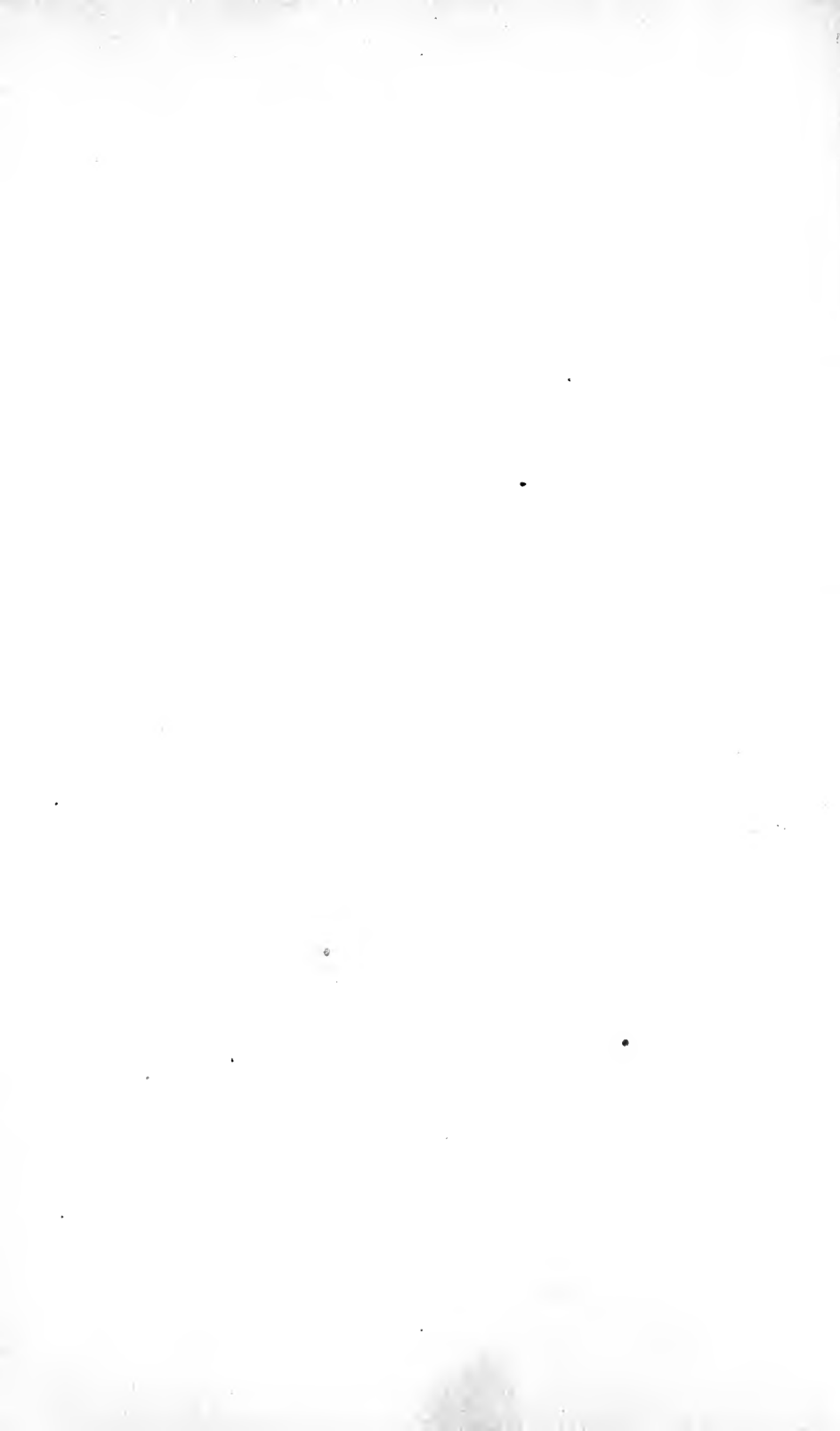

INDEX.

A.

- Absolute measurements, 5.
- Accidental errors, axioms of, 29.
 - errors, criteria of, 121.
 - errors, definition of, 26
 - errors, law of, 29, 35.
- Adjusted effects, 149.
- Adjustment of the angles about a point, 81.
 - of the angles of a plane triangle, 93.
 - of instruments, 15, 183.
 - of measurements, 21, 42, 63, 72.
- Applications of the method of least squares, 203.
- Arithmetical mean, characteristic errors of, 51.
 - mean, principle of, 29.
 - mean, properties of, 42.
- Average error, defined, 44.
- Axioms of accidental errors, 29.

B.

- Best magnitudes for components,
 - fundamental principles, 165.
 - general solutions, 167.
 - practical examples, 173.
 - special cases, 170.

C.

- Characteristic errors, defined, 44.
 - errors, computation of, 53, 57, 66, 71, 99, 101, 112, 114.
 - errors of the arithmetical mean, 51.
 - errors, relations between, 49.
- Chauvenet's criterion, 127.
- Computation checks for normal equations, 83.
- Conditioned measurements, 17.
 - quantities, determination of, 92.

- Constant errors, elimination of, 117.
 - errors, defined, 23.
- Conversion factor, defined, 3.
 - factor, determination of, 8.
- Correction factors, defined, 131.
- Criteria of accidental errors, 121.
- Criticism of published results, proper basis for, 117.
- Curves, use of, in reducing observations, 198.

D.

- Dependent measurements, 17.
- Derived measurements, defined, 12.
 - measurements, precision of, 135.
 - quantities, defined, 95.
 - quantities, errors of, 99.
 - units, 4.
- Dimensions of units, 5.
- Direct measurements, defined, 11.
 - measurements, precision of, 130.
- Discussion of completed observations, 117.
 - of proposed measurements, general problem, 145.
 - of proposed measurements, preliminary considerations, 144.
 - of proposed measurements, primary condition, 146.

E.

- Effective sensitiveness of instruments, 183.
- Equal effects, principle of, 147.
- Equations, observation, 74.
 - normal, 75.
- Error, average, 44.
 - fractional, 101.
 - mean, 46.
 - probable, 47.

Error, —*Continued.*

- unit, 31.
- weighted, 67.
- Errors, accidental, 26.
 - characteristic, 44.
 - constant, 23.
 - definition of, 18.
 - of adjusted measurements, 105.
 - of derived quantities, 99.
 - of multiples of a measured quantity, 98.
 - of the algebraic sum of a number of terms, 95.
 - of the product of a number of factors, 102.
 - percentage, 104.
 - personal, 25.
 - propagation of, 95.
 - systematic, 118.
 - systems of, 33.
- Examples, see Numerical examples.

F.

- Fractional error, defined, 101.
 - error of the product of a number of factors, 102.
- Free components, 169.
- Functional relations, determination of, 15, 195, 198, 203.
- Fundamental units, 4.

G.

- Gauss's method for the solution of normal equations, 84.
- General mean, 63.
 - principles, 1.
- Graphical methods of reduction, 198.

I.

- Independent measurements, 17.
- Indirect measurements, 11.
- Intrinsic sensitiveness of instruments, 183.

L.

- Law of accidental errors, 29, 35.
- Laws of science, 2.
- Least squares, method of, 72.

M.

- Mathematical constants, use of, in computations, 153.
- Mean error, defined, 46.
- Measurement, defined, 2.
- Measurements, absolute, 5.
 - adjustment of, 21, 42, 63, 72.
 - derived, 12.
 - direct, 11.
 - discussion of, 117, 144.
 - independent, dependent, and conditioned, 17.
 - indirect, 11.
 - precision of, 19, 130, 135.
 - weights of, 61.
- Method of least squares, applications of, 203.
 - of least squares, fundamental principles of, 72.
- Mistakes, 26.

N.

- Negligible components, 154.
 - effects, 151.
- Normal equations, computation checks for, 83.
 - equations, derivation of, 75.
 - equations, solution by determinants, 114.
 - equations, solution by Gauss's method, 84.
 - equations, solutions by indeterminate multipliers, 105.
 - equations, solution with two independent variables, 78.
- Numeric, defined, 2.
- Numerical examples:
 - Adjustment of angles about a point, 81.
 - Adjustment of angles of a plane triangle, 93.
 - Application of Chauvenet's criterion, 129.
 - Best magnitudes for components, 173, 175, 180.
 - Characteristic errors of direct measurements, 56, 70.

Numerical examples — *Continued.*

- Coefficient of linear expansion, 78.
- Discussion of proposed measurement, 157.
- Effective sensitiveness of potentiometer, 190.
- Errors of a derived quantity, 101.
- Fractional errors, 101.
- Precision of completed measurement, 140.
- Probable errors of adjusted measurements, 113, 115.
- Probable error of general mean, 69.
- Propagation of errors, 101.
- Solution of normal equations by Gauss's method, 88.
- Weighted direct measurement, 69.

O.

- Observation, defined, 15.
 - equations, 74.
 - standard, 62.
- Observations, record of, 16.
 - report of, 211.
 - representation of, by curves, 198.

P.

- Percentage errors, 104.
- Personal equation, 26.
 - errors, 25.
- Physical tables, use of, 138.
- Precision constant, 35.
- Precision of derived measurements, 135.
 - of direct measurements, 130.
 - of measurement, defined, 19.
- Precision measure, defined, 132.
- Preliminary considerations for selecting methods of measurement, 144.
- Primary condition, 146.
- Principle of the arithmetical mean, 29.
 - of equal effects, 147.
- Probability curve, 32.
 - function, 34.

Probability curve — *Continued.*

- function, comparison with experience, 40.
- integral, 37.
- of large residuals, 124.
- of residuals, 30.
- principles of, 28.
- Probable error, defined, 47.
 - error of adjusted measurements, 111, 112, 116.
 - error of the arithmetical mean, 53.
 - error of direct measurements, computation of, 54, 55, 57.
 - error of the general mean, 66, 68.
 - error of a single observation, 54, 68, 108.
 - error of a standard observation, 62.
- Propagation of errors, 95.
- Publication, 209.

R.

- Research, fundamental principles, 192.
 - general methods, 193.
- Residuals, defined, 27.
 - distribution of, 29.
 - probability of, 30, 124.

S.

- Sensitiveness of methods and instruments, 183.
- Separate effects of errors, 133, 135.
- Setting of instruments, 15.
- Sign-changes, defined, 123.
- Sign-follows, defined, 123.
- Significant figures, use of, 19, 58.
- Slugg, defined, 9.
- Special functions, treatment of, 155.
- Standard observation, defined, 62.
- Systematic errors, defined, 118.
- Systems of errors, 33.
 - of units, 7.

T.

- Tables, list of, ix.
- Transformation of units, 8.
- Treatment of special functions, 155.

U.

- Unit error, 31.
- Units, c.g.s. system, 7.
 - dimensions of, 5.
 - engineer's system, 7.
 - fundamental and derived, 4.
 - systems in general use, 7.
 - transformation of, 8.
- Use of physical tables, 138.
 - significant figures, 19, 58.

W.

- Weighted errors, 67.
 - mean, 63.
- Weights of adjusted measurements,
 - 105, 112, 114.
 - of direct measurements, 61.



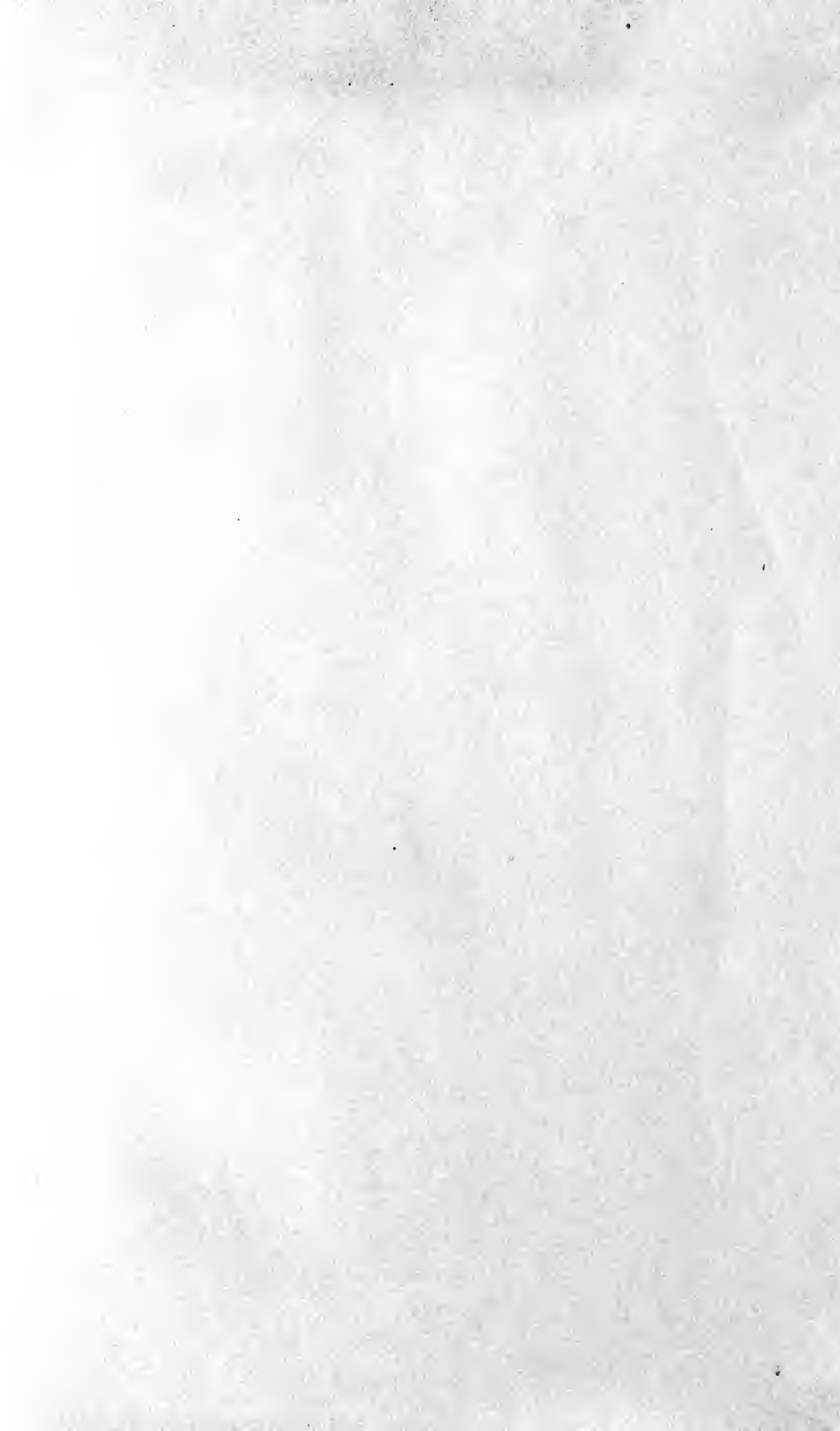

RETURN TO **CIRCULATION DEPARTMENT**
202 Main Library

LOAN PERIOD 1	2	3
HOME USE		
4	5	6

ALL BOOKS MAY BE RECALLED AFTER 7 DAYS

Renewals and Recharges may be made 4 days prior to the due date.

Books may be Renewed by calling 642-3405.

DUE AS STAMPED BELOW

SEP 04 1988

AUG 04 1989

Rec'd UCB A/M/S

AUG 17 1988

UNIVERSITY OF CALIFORNIA, BERKELEY
BERKELEY, CA 94720

FORM NO. DD6,

©s

GENERAL LIBRARY - U.C. BERKELEY



8000313835

THE UNIVERSITY OF CALIFORNIA LIBRARY

