

UC-NRLF



QB 26 363

LIBRARY
OF THE
UNIVERSITY OF CALIFORNIA.

Class



THE
THEORY OF STRUCTURES

BY

R. J. WOODS, M.E., M.INST.C.E.

FELLOW AND FORMERLY ASSISTANT PROFESSOR OF ENGINEERING,
ROYAL INDIAN ENGINEERING COLLEGE, COOPER'S HILL
AUTHOR OF 'THE STRENGTH AND ELASTICITY OF STRUCTURAL MEMBERS'

WITH 157 ILLUSTRATIONS



LONDON
EDWARD ARNOLD
1909

[All rights reserved]

TG 260
WG

GENERAL

UNIFORM WITH THIS VOLUME.

THE STRENGTH AND
ELASTICITY OF
STRUCTURAL MEMBERS.

By R. J. WOODS, M.E., M.Inst.C.E.

With 292 Illustrations.

Pp. xii. + 316. Demy 8vo, 10s. 6d. net.

SECOND EDITION, REVISED.

LONDON : EDWARD ARNOLD.

PREFACE.

THE favourable reception accorded to my book entitled 'The Strength and Elasticity of Structural Members' has induced me to write the present volume on 'The Theory of Structures.' This new volume, although self-contained and independent, forms a continuation of the previous one, suitable for more advanced students and draughtsmen engaged in structural design. The elementary principles and formulæ of the former volume are extended and utilised for the determination of the stresses in, and the design of, masonry and steel structures.

Experience in the practical design of structures, and the teaching of students, has convinced me of the great importance of numerical examples for presenting the methods of design in a clear and intelligible form. I have consequently devoted a large part of this book to the working out of practical examples, in the hope that it may form not only a useful text-book for Engineer students at the Universities and Technical Colleges, and those proceeding to the Examination for the Associate Membership of the Institution of Civil Engineers, but also that it may form a useful book of reference to Engineers and Architects engaged in the design of structures.

Chapter I. deals with principal stresses, and the ellipse of stress so far as to make clear the theory of earth pressure, and to explain the geometrical constructions for obtaining the thrust on retaining walls in Chapter II. In Chapter III., the stresses due to eccentric loading are considered, and the conditions of

stability of masonry structures fully analysed. Chapters IV. to VII. deal with girders of various types—girders with parallel chords, parabolic girders, and curved girders not parabolic. Numerical examples are given for each of these types, and the stresses obtained in the different members due to dead and live loads. These stresses are then utilised for the practical design of the members.

Chapter VIII. is devoted to the important subjects of wind pressure, portal bracing, and the design of high trestles, each of which is dealt with as a practical numerical example. In Chapters IX. and X. the maximum shearing forces and bending moments due to both dead and live loads are obtained for continuous girders, cantilever girders, suspension and stiffening girders.

In Chapter XI. the strength of riveted joints is considered, and numerous practical examples of the design of such joints are worked out.

Chapter XII. gives the design for a plate girder 60 feet span.

Chapter XIII. deals with the strength of columns and struts in cast iron, wrought iron, and steel, with several applications of the results to the actual design of struts. Chapter XIV. treats very fully of the design of arched ribs and braced arches. Numerical examples are taken, and the stresses obtained for dead and live loads.

The final chapter is devoted to the theory of reinforced concrete, an important branch of Structural Engineering. Examples of beams, T beams, floors, columns, and retaining walls have been fully worked out.

R. J. W.

ENGLEWOOD, ENGLEFIELD GREEN :

June 1909.

CONTENTS.

	PAGE
CHAPTER I.—COMPOUND STRESSES. PRINCIPAL STRESSES.	
Combination of a pair of stresses on planes at right angles	1
Given the principal stresses to determine the resultant stress on a third plane	3
Principal stresses. Definition	4
Axes of principal stress	4
Ellipse of stress. Given the principal stresses to determine the resultant stress on a third plane	5
Equal like principal stresses. Equal unlike principal stresses	6
Determination of the planes of principal stress, and the magnitude of principal stress on those planes	7
To determine the plane for which the obliquity of the resultant stress is the greatest possible	8
Conjugate stresses	10
To find the ratio of the intensities of two conjugate stresses whose common obliquity is given	10
CHAPTER II.—EARTH PRESSURE.	
Angle of repose. Coefficient of friction	13
Condition of equilibrium of a mass of earth	14
Pressure against a retaining wall with vertical back. Earth horizontal	15
Pressure against a retaining wall with vertical back. Surcharged with earth at a uniform slope	16
Retaining wall surcharged with earth at a uniform slope. Geometrical construction from ellipse of stress	18
Depth of foundations in earth	19
Numerical examples :—	
1. Retaining wall with vertical back. Earth horizontal. Magnitude and direction of resultant pressure	20
2. Retaining wall with vertical back. Surcharged. Magnitude and direction of resultant pressure	21
3 and 4. Determination of the least depth to which foundations must be sunk in earth	23
5. Magnitude and direction of resultant pressure on back of retaining wall found geometrically from ellipse of stress	24
Wedge theory of earth pressure explained	26
Maximum earth thrust according to wedge theory.	26

	PAGE
Resultant pressure on retaining wall, friction being taken into account	29
Graphic methods of determining maximum earth thrust from wedge theory :—	
Case I. Surface of earth horizontal	30
Case II. Surcharged retaining wall	31
Example. To find the resultant thrust on a retaining wall surcharged with earth at a uniform slope. Solved geometrically by the wedge theory	33
CHAPTER III.—STRESSES DUE TO ECCENTRIC LOADS.	
STABILITY OF MASONRY STRUCTURES :—	
Stress on a section or plane joint. Load non-axial	34
Reduction of strength due to non-axial loading	36
Neutral axis of stress	37
Limiting position of centre of pressure	37
" " " for rectangular joint	38
" " " for circular joint	39
Extreme intensities of stress for a rectangular section	40
Numerical examples of stresses for various sections due to eccentric loading	41-44
Conditions of stability of masonry structures	45
Moment of stability. External moment	45
Line of resistance	46
Limiting intensities of pressure	46
Frictional stability	47
Masonry dams	48
Approximate section for high dams	49
Numerical examples :—	
1. Stability of masonry pier due to wind pressure	49
2. " " " horizontal thrust	50
3. Stability of a masonry buttress	51
4. Limiting height for a masonry dam of trapezoidal section	53
" " " triangular section	54
5. Maximum intensity of pressure on base of a masonry dam trapezoidal in section	54
Shear on base of dam	55
6. Discussion regarding the maximum intensities of stress on base of a masonry dam	55
Height to which a masonry dam of triangular section may be built consistent with conditions of stability	57
Line of resistance for a masonry dam : (a) reservoir empty ; (b) reservoir full	59
CHAPTER IV.—WORKING STRESSES AND CROSS SECTIONAL AREAS. STRESSES IN GIRDERS WITH PARALLEL CHORDS BY METHOD OF COEFFICIENTS.	
Forms of girders. Chords and web	61
Loads on girders. Dead load. Live load	61

	PAGE
Counterbracing	62
Working stress. Launhardt's and Weyrauch's method	63
" " Dynamic method	63
" " Coefficient rule	64
Numerical examples for determining the working stress and sectional area of members	65
Stresses in web members of girders with parallel chords by method of coefficients.	68
Stresses in chord members by method of coefficients	68
Numerical examples for determining the stresses in girders with parallel chord by method of coefficients :—	
1. Warren girder. 100 feet span	69
2. Pratt girder. 104 feet span	70
3. Girder formed of isosceles triangular bracing with vertical ties from upper chord	72
4. Girder with web of double triangulation	76

CHAPTER V.—GIRDERS WITH PARALLEL CHORDS.
GENERAL METHOD.

Distribution of dead load	79
Stresses in bracing and chord members due to dead load	80
Numerical examples of stresses in girders with parallel chords due to dead load :—	
1. Pratt truss. General method of tabulation	81
2. " " 112 feet span	82
3. Warren girder. 120 feet span	83
4. Girder formed of triangular bracing with verticals which subdivide the bays of loaded chord members into half bays. Span 120 feet	85
5. Warren girder, 100 feet span, with web of double triangulation	86
6. Linville truss or girder with web of double triangulation of the Pratt type. Span 175 feet	87
7. Whipple truss. Span 240 feet	89

CHAPTER VI.—PARABOLIC GIRDERS.

Horizontal components of stress in chords is constant	91
No stress in diagonal braces when girder is fully loaded	92
Depths of parabolic girder at the panel points	92
Inclination of bays of polygonal chord and of diagonals	93
Maximum stress in chord members	94
" " web members for single triangulation	95
Stress in diagonal braces found graphically	96
Resultant stresses due to dead and live loads in diagonal braces and verticals	97
Stresses in web braces formed of double triangulation	98
Numerical example of parabolic girder. 150 feet span.	99

	PAGE
CHAPTER VII.—CURVED GIRDERS NOT PARABOLIC.	
Numerical example of curved girder, span 130 feet, for bridge to carry a single line of railway :—	
Dead load	101
Live load. Type of	102
Stresses due to dead load :—	
Chords	102
Braces	103
Verticals	103
Maximum bending moments due to live load found graphically .	104
Stresses due to live load :—	
Chords	107
Braces	108
Verticals	109
Wind load. Specification	110
Stresses due to wind load	111
Resultant stresses. Chords	112
" " Braces	112
" " Verticals	113
Design of members. Chords	113
" " Braces	115
" " Verticals	115
Connexion of braces to verticals and chords	117
Design of end post	117
CHAPTER VIII.—WIND PRESSURE. PORTAL BRACING. HIGH STEEL TRESTLES.	
Arrangement of lateral wind bracing	118
Specifications for wind pressure	119
Object of portal bracing	120
Example of wind bracing for a Pratt girder	120
Upper lateral system. Dead wind panel load	121
Overturning moment due to wind load. Reactions and stresses	121
Stresses due to wind load on train	121
Lower lateral system. Dead wind load	122
Computation of wind stresses in bracing	122
Resultant chord stresses	123
Design of portal bracing. Example I.	123
" " Example II.	125
Sway bracing	126
Steel trestles	126
Numerical example of railway viaduct formed of plate girders carried on steel trestles	
	127-135
Dead load stresses	128
Live load stresses	130
Stresses due to the sudden retardation of train	130
Wind loads	131

	PAGE
Stresses in columns due to wind	132
„ horizontal struts due to wind	133
Stress in diagonals	133
Overturning moment and moment of stability	134
Summary of maximum stresses. Columns	134
„ „ „ „ Diagonals	135
General design of members	135

CHAPTER IX.—CONTINUOUS GIRDERS.

Bending moment at any section of continuous girder loaded with uniform load	136
Graphic representation of bending moment	137
Theorem of three moments. Uniform loading	139
„ „ „ Concentrated loads	142
Reactions	142
Example of continuous girder of two unequal spans, with uniform loading	143
Example of continuous girder of three spans, with uniform loading	144
Example of continuous girder of two equal spans, loaded with concentrated loads	146
Reactions	147
Points of inflection	147
Maximum shearing forces and bending moments in a continuous girder due to live loads	148
Numerical example of continuous girder, 160 feet long, covering two spans of 80 feet	150
Determination of the maximum and minimum stresses in chords and braces of above example due to dead and live loads	151
Swing bridge	153
Continuous girder with supports not on the same level.	153
Numerical examples of continuous girders with piers not on the same level	154
Advantages and disadvantages of continuous girders	155

CHAPTER X.—CANTILEVER GIRDERS. SUSPENSION AND STIFFENING GIRDERS.

Object of hinges	156
Hinges in central span	157
„ side spans	158
Chain uniformly loaded	160
Approximate length of cable	161
Pressure on piers	162
Stiffening girder	162
Stiffening girder without central hinge. Maximum bending moments and shearing forces	163
Stiffening girder hinged at the centre. Maximum bending moments and shearing forces	164
Stiffening girder hinged at the centre. Maximum bending moments due to a single live load	166

CHAPTER XI.—DESIGN OF RIVETED JOINTS.

PAGE

Definitions. Lap and butt joints	169
Rules to be observed in designing joints	171
Strength of riveted joints	172
Multiple riveted joints	174
Strength of plates and rivets in riveted joints	174
Single riveted lap joint	174
" " butt joint with one cover	174
Double riveted lap joint	175
" " butt joint with single cover	175
Single riveted butt joint with two covers	175
Double riveted butt joint with two covers	175
Thickness of cover plates	176
Efficiency of riveted joints. Tensile, shear, compression	176
Group riveted joint of greatest economy	177
Numerical example of zig-zag double riveted butt joint with one cover	179
Jointing of two or more plates	180
Numerical examples of various riveted joints	180
Connexion of inclined brace of Pratt truss to gusset plate of chord	180
Connexion of vertical post to gusset plates of chord	182
Connexion of gusset plates to chords. Design of joints in top plate and side plates of chord	183
Angle splices	185
Plate girder. Riveting of web to flanges	185
Numerical examples for determining the pitch of rivets connecting angles to plate web	186

CHAPTER XII.—PLATE GIRDERS.

Numerical example for the design of a plate girder, span 60 feet, to carry a single line of railway	188-203
Working stresses	188
Dead and live loads specified	188
Weight of main girders	188
Spacing of cross girders	189
Main girder. Maximum bending moments due to dead load	189
" " " " " " " live load	190
" " " " " " " dead and live loads	191
Section of main girder	192
Length of plates	193
Thickness of web of main girder	195
Rivet pitch in flanges	196
Distance from support at which pitch may be doubled	197
Web splices	197
Joints in plates of upper and lower chords	198
" longitudinal angle irons	200

	PAGE
Stiffeners	201
Cross girder. Dead and live loads	202
Cross section of cross girder	202
Thickness of web of cross girder	203
Pitch of rivets connecting angles to web in cross girder	203
Attachment of cross girder to main girder	203

CHAPTER XIII.—COLUMNS AND STRUTS.

Short columns	205
Rankine's formula for strength of columns or struts	205
Values of constants for Rankine's formula	206
Gordon's formula for the strength of columns	206
Values of constants in Gordon's formula	207
Modification of above formulæ as depending on the method of fixing	207
Design of struts	208
Numerical examples for determining the safe load for struts of various cross sections	209
Design for the cross section of a vertical post of a girder	211
Euler's formula for long columns	212
Rankine's formula a modification of Euler's	213
Johnson's parabolic formula	214
Mr. T. H. Johnson's straight line formula	216
Columns with non-axial or eccentric loads	216
Numerical example of non-axial load on a strut of T-section	217

CHAPTER XIV.—ARCHED RIBS AND BRACED ARCHES.

Unbraced or rigid arch. Braced arch	219
Curve of pressures or linear arch	219
Bending moment and thrust in an arched rib	220
Example of a semicircular arch rib. To determine the position and value of the maximum bending moment	221
Arch with three hinges. Loads vertical	223
Braced arches. Two types	224
Stresses in a braced arch with three hinges	225
Numerical example of steel braced arch, 160 feet span. Stresses found graphically and checked by moments	225
Live load stresses in braced arch	228
To determine the distribution of live load necessary to produce maximum stresses of tension and compression in chord members	228
To determine the distribution of live load necessary to produce maximum tension and compression in diagonal braces	229
Distribution of live load that produces maximum compression and tension in verticals	230
Numerical example of steel braced arch with three hinges. Span 150 feet, rise 30 feet	231
Parabolic arch rib. Hinges at ends only	235
Reaction locus	236

	PAGE
Horizontal thrust	236
Bending moments	237
Temperature stresses	237
Numerical example of parabolic arched rib in which the reaction locus is plotted and bending moments obtained	237
Bending moments in above arched rib checked from the vertical and horizontal components of reactions	240
Temperature thrust	242
Shear in parabolic rib	242
Numerical example of shear in parabolic rib	244
 CHAPTER XV.—REINFORCED CONCRETE.	
Advantages of reinforced concrete	245
Working stresses	246
Adhesion	246
Shear reinforcement for web	246
Ratio of modulus of elasticity of steel to that of concrete	247
Notation	247
General theory for reinforced concrete beams neglecting the tensional resistance of concrete and assuming a straight line distribution of stress	247
Position of neutral axis	248
Moment of resistance	249
Numerical examples of the design of reinforced beams	251
„ example of floor slab reinforcement	258
Theory of reinforced beams assuming a parabolic distribution of stress for compression	254
Professor Talbot's formulæ for beams	255
Reinforced concrete floors	256
Formulæ for T-beams, assuming a straight line variation of compressive stress	257
Neutral axis in flange	258
„ „ web	258
Numerical examples of T-beams and floors	259
Beams reinforced for compression and tension	262
Reinforced columns	264
Numerical examples of reinforced columns	265
Bending and direct stress. Non-axial loads	265
Numerical examples of bending and direct stress due to eccentric loads	269
Design for reinforced concrete retaining wall	271
Horizontal reinforcement for retaining wall	271
Vertical reinforcement for retaining wall	274
Width of foundation of retaining wall	275
Reinforcement for counterforts of retaining wall	275
„ „ foundation slab of retaining wall	275



THE THEORY OF STRUCTURES.

CHAPTER I.

COMPOUND STRESSES—PRINCIPAL STRESSES.

1. Combination of a pair of simple longitudinal stresses in directions at right angles to one another.

Let $ABCD$ be a small rectangular block of material of unit thickness whose sides are perpendicular to the stresses f_1, f_2 .

To determine the intensities of the normal and tangential stresses on any inclined plane BD , the normal to which makes an angle θ with the direction of f_1 .

(a) LIKE STRESSES. (Both compression or both tension.)

Let f_n and f_t be the intensities of the normal and tangential stresses on the plane BD .

Consider the separate equilibrium of the parts into which the block is divided by the diagonal plane of section BD (Fig. 1).

The total stress on each of the faces AB and $CD = f_1 AB$.

The total stress on each of the faces BC and $AD = f_2 BC$.

Resolving perpendicular to BD for the normal stress,

$$f BD = f_1 AB \cos \theta + f_2 BC \sin \theta.$$

Therefore $f_n = f_1 \cos^2 \theta + f_2 \sin^2 \theta \dots\dots\dots(1).$

To get the tangential or shearing stress, resolve along BD

$$f_t BD = f_1 AB \sin \theta - f_2 BC \cos \theta.$$

Therefore $f_t = (f_1 - f_2) \sin \theta \cos \theta$
 $= \frac{(f_1 - f_2)}{2} \sin 2\theta \dots\dots\dots(2).$

If $f_1 = f_2$, then $f_n = f_1$; and $f_t = 0$.

From (2) we see that the tangential stress is a maximum when $\theta = 45^\circ$:

$$\text{Max. } f_t = \frac{f_1 - f_2}{2}.$$

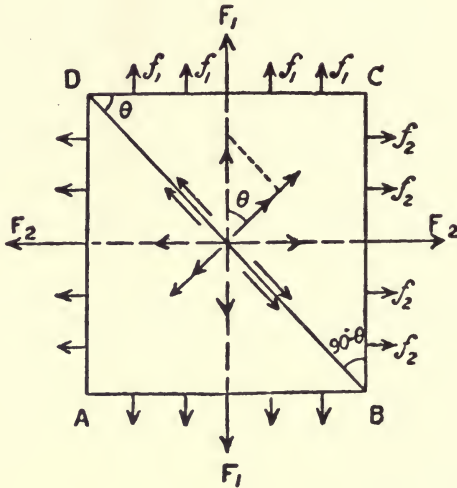

Fig. 1.

The normal stress on the same plane inclined at 45° is

$$\frac{f_1 + f_2}{2}.$$

(b) UNLIKE STRESSES. (One compression, the other tension.)

If the stresses f_1 and f_2 are of opposite sign, f_1 being a tension and f_2 a thrust (Fig. 2), then the intensity of the normal stress on BD is

$$f_n = f_1 \cos^2 \theta - f_2 \sin^2 \theta.$$

The intensity of the tangential stress on BD

$$f_t = (f_1 + f_2) \sin \theta \cos \theta = \frac{f_1 + f_2}{2} \sin 2\theta.$$

In this case, if the stresses are *equal intensity* f_1 , then on a plane *inclined at* 45° there is no normal stress. There exists only a tangential or shearing stress on the two planes inclined at 45°

to the axes along which the stresses act. The intensity of this shearing stress is

$$\frac{2f_1}{2} = f_1.$$

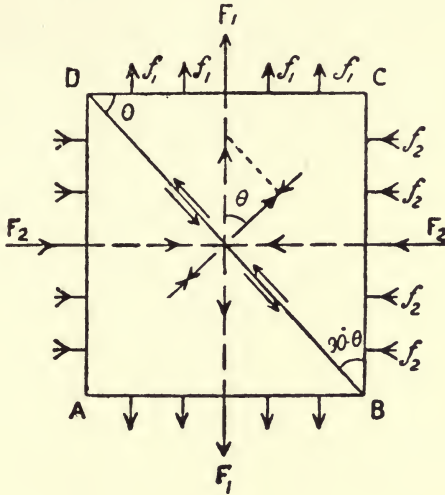

Fig. 2.

To find the magnitude and direction of the intensity of the resultant stress on the plane BD (Fig. 1). Like stresses.

Let f be the intensity of the resultant stress.

Then, since fBD is the resultant of $f_1 AB$ and $f_2 BC$ acting at right angles to each other,

$$\begin{aligned} fBD &= \sqrt{f_1^2 AB^2 + f_2^2 BC^2} \\ &= BD \sqrt{f_1^2 \cos^2 \theta + f_2^2 \sin^2 \theta}. \end{aligned}$$

Therefore $f = \sqrt{f_1^2 \cos^2 \theta + f_2^2 \sin^2 \theta} \dots\dots\dots(3).$

Let a be the angle which resultant stress makes with the direction of f_1 , then

$$\tan a = \frac{f_2 BC}{f_1 AB} = \frac{f_2 \sin \theta}{f_1 \cos \theta} = \frac{f_2}{f_1} \tan \theta \dots\dots\dots(4).$$

Unlike Stresses.—If the stresses f_1 and f_2 are of opposite sign—say $f_2 = -f_2$ —then

$$\tan a = -\frac{f_2}{f_1} \tan \theta;$$

that is, the resultant stress makes the same angle with the direction of f_1 , as in the case of like stresses, but lies on the opposite side of it.

2. Principal stresses.

Planes on which the stresses are *wholly normal* are called *planes of principal stress*, and the stresses themselves *principal stresses*.

Let AB and CD (Fig. 3) be a pair of rectangular planes through O upon which the stresses are wholly normal; they are the *planes of principal stress*; the stresses themselves are called the *principal stresses* at O , and their directions (OX , OY) are called the *axes of principal stress*. The axes of principal stress have the property that the intensity of stress along one of them is greater and along another is less than in any other direction. These are respectively called the axes of greatest and least principal stresses. The greatest principal stress is important to determine, as it measures the greatest intensity of stress which the material has to bear.

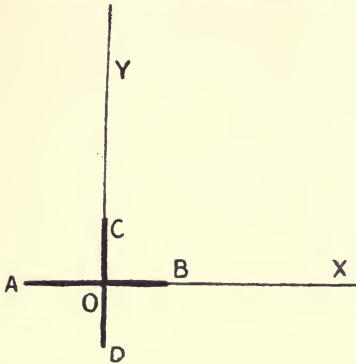

Fig. 3.

3. Ellipse of stress.

A state of stress in two dimensions can always be represented by an ellipse, the semi-axes of which are the principal stresses, and their directions the axes of stress.

Given a pair of principal stresses, f_1 and f_2 , acting at right angles to one another, to determine the magnitude and direction of the resultant stress on a plane whose normal is inclined to the direction of f_1 at an angle θ , in terms of the principal stresses.

The resultant stress may be found graphically as follows:—

In Fig. 4, OD and OB are the planes of principal stress and BD is the plane inclined at an angle θ to OD , the axis of f_1 .

On the perpendicular to the plane BD , set off OQ to represent f_1 , and OP to represent f_2 . Draw QM perpendicular to f_1 , and PR parallel to f_1 to meet QM in R . Describe circles with radii f_1 and f_2 from O as centre.

Then OR represents the resultant stress on the plane BD in magnitude and direction, and the locus of R is an ellipse.

Let f be the intensity of the resultant stress, and let a be the angle which its direction makes with the axis f_1 .

Now $OQ = f_1$; $OP = f_2$.

And $OM = OQ \cos \theta = f_1 \cos \theta$

$RM = OP \sin \theta = f_2 \sin \theta$.

Therefore $f = OR = \sqrt{f_1^2 \cos^2 \theta + f_2^2 \sin^2 \theta} \dots\dots\dots (5).$

And $\tan a = \frac{RM}{OM} = \frac{f_2}{f_1} \tan \theta \dots\dots\dots (6).$

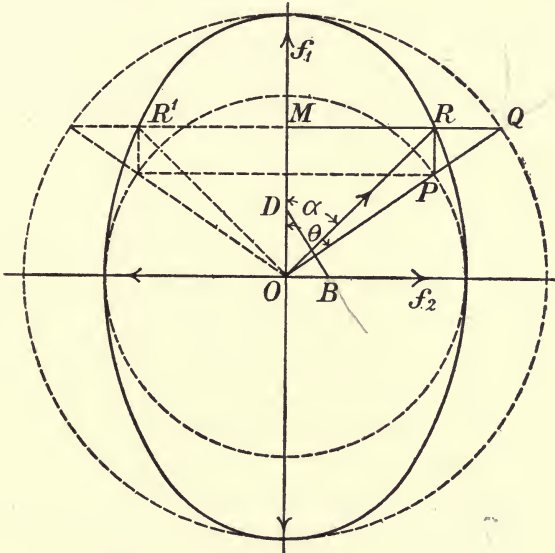

Fig. 4.

Equations (5) and (6) are the same as Equations (3) and (4)— OR represents the intensity of stress on the plane BD in magnitude and direction. In the limit, when the triangle ODB becomes very small, then D and B coincide with O .

Let x, y be the co-ordinates of R ,

then $x = RM = f_2 \sin \theta = f \sin a \dots\dots\dots (7).$

$y = OM = f_1 \cos \theta = f \cos a \dots\dots\dots (8).$

And $\frac{x}{f_2} = \sin \theta, -\frac{y}{f_1} = \cos \theta.$

Therefore $\frac{x^2}{f_2^2} + \frac{y^2}{f_1^2} = 1, \text{ and } \tan a = \frac{f_2}{f_1} \tan \theta.$

Thus R lies on an ellipse, called the ellipse of stress, with its axes ($2f_1$ and $2f_2$) lying in the planes of principal stress. The semi-axes are equal to the principal stresses. If the pair of stresses, f_1, f_2 , have opposite signs, then f_2 must be set off on the opposite side of O , and OR the radius vector of ellipse lies on the other side of OM .

If $f_1 = f_2$, OR is at right angles to BD , and the ellipse becomes a circle. Thus: (a) If a pair of principal stresses at a point be of *like* sign (both compression or both tension) and be *equal* in intensity, then the stress on any third plane through the point is of the same intensity and is normal to the plane (see Fig. 5); (b) If the pair of principal stresses be *unlike* (one tension and the other compression) and be of *equal* intensity ($f_1 = -f_2$), the resultant stress on any other plane is of the same intensity, but, since in this case $\tan a = -\tan \theta$, the line of action of the

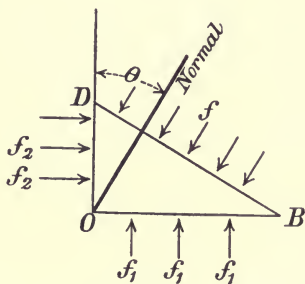

Fig. 5.

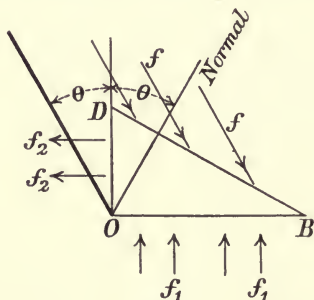

Fig. 6.

resultant stress makes the same angle with OM as the normal to the plane, but lies on the opposite side of OM to the resultant in case (a) (see Fig. 6).

4. To determine the planes of principal stress, and the magnitude of the principal stress on these planes.

Suppose f_1 and f_2 of the preceding article to be replaced by stresses of any magnitude and direction on two faces at right angles. Resolve these stresses into normal and tangential components. The tangential components must be equal. Let f_n and f_n^1 be the intensities of the normal components, and q the intensity of the equal tangential components on the two planes at right angles (Fig. 7). It is required to find a plane DB such that the stress on it is *wholly normal*, and to determine f the intensity of that stress. Let θ be the angle which BD makes with DO . Consider the equilibrium of the right prism DBO of unit thickness.

Resolving vertically, we get

$$f DB \cos \theta = q BO + f_n DO ;$$

that is, $f - f_n = q \tan \theta \dots\dots\dots(9).$

Resolving horizontally,

$$f - f_n^1 = q \cot \theta \dots\dots\dots(10).$$

Subtracting

$$f_n - f_n^1 = q (\cot \theta - \tan \theta) = 2q \cot 2 \theta.$$

Therefore

$$\tan 2 \theta = \frac{2q}{f_n - f_n^1} \dots\dots\dots(11).$$

Two values of θ satisfy this equation—that is, $\theta = \theta$ and $\theta = 90^\circ + \theta$. Thus there are two planes at right angles to each

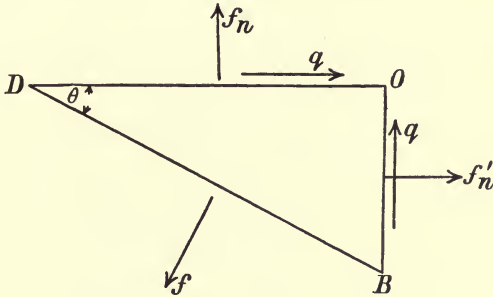

Fig. 7.

other on which the stress is wholly normal—that is, there are two principal planes.

The value of the principal stress on these planes is got by multiplying (9) and (10).

$$(f - f_n) (f - f_n^1) = q^2.$$

$$f^2 - f (f_n + f_n^1) + f_n f_n^1 - q^2 = 0.$$

The two roots of this equation give the two principal stresses, solving—

$$f = \frac{f_n + f_n^1}{2} \pm \frac{1}{2} \sqrt{(f_n - f_n^1)^2 + 4q^2} \dots\dots\dots(12).$$

From (12) it follows that the sum of the normal components of stress on any two rectangular planes is equal to the sum of the principal stresses.

5. To determine the plane BD , so that the resultant stress on it makes the greatest possible angle with the normal to the plane.

Let f_1 and f_2 be the principal stresses, both of the same sign, and f_1 greater than f_2 .

Then
$$f_1 = \frac{f_1+f_2}{2} + \frac{f_1-f_2}{2} \text{ an identity,}$$

and
$$f_2 = \frac{f_1+f_2}{2} - \frac{f_1-f_2}{2} \text{ an identity.}$$

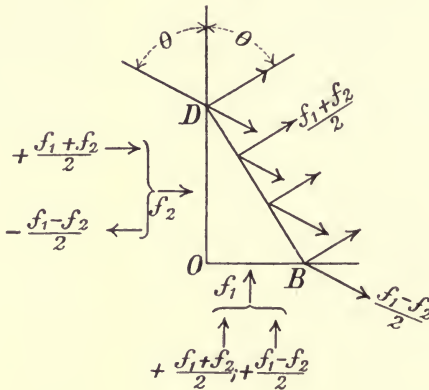

Fig. 8.

By Art. 3 the resultant stress due to the pair of *equal-like* principal stresses is of intensity $\frac{f_1+f_2}{2}$ and normal to BD . The stress on BD due to the *equal-unlike* principal stresses $\frac{f_1-f_2}{2}$ is of intensity $\frac{f_1-f_2}{2}$ inclined at an angle θ on the opposite side of the direction of f_1 (Fig. 8).

Compound these by the triangle of forces (Fig. 9). From O set off ON in the direction of the normal ONS to the plane to represent $\frac{f_1+f_2}{2}$. From N draw NR to represent $\frac{f_1-f_2}{2}$ in a direction parallel to OQ , making an angle 2θ with the normal ON . Then OR the third side of the triangle ONR , taken in the *reverse* order to the other two forces, will represent in magnitude and direction the intensity of the resultant stress on BD .

It can be seen that the angle $RON = \beta$ will be a *maximum* when NR is perpendicular to RO .

In this case, since the angle $ORN = 90^\circ$,

$$OR^2 = ON^2 - RN^2;$$

or,
$$f^2 = \left(\frac{f_1 + f_2}{2}\right)^2 - \left(\frac{f_1 - f_2}{2}\right)^2 = f_1 f_2.$$

Therefore $f = \sqrt{f_1 f_2}$(13).

Also $\sin \beta = \frac{f_1 - f_2}{f_1 + f_2}$(14),

and $\cos 2\theta = -\frac{RN}{ON} = -\frac{f_1 - f_2}{f_1 + f_2}$(15).

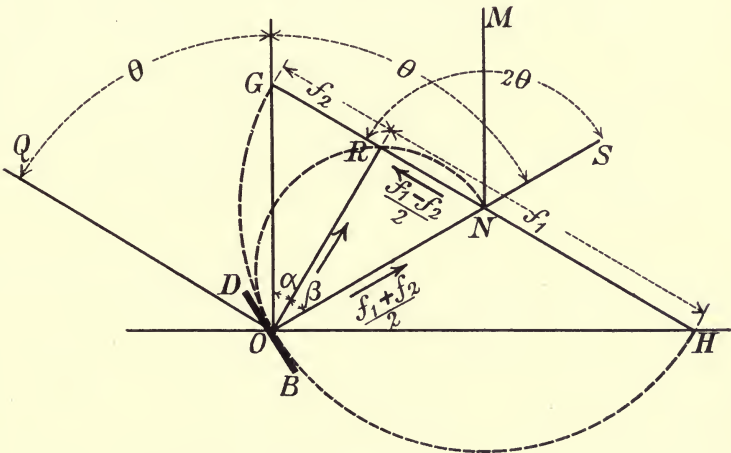

Fig. 9.

From Equations (7) and (8) $\tan \alpha = \frac{f_2}{f_1} \tan \theta$.

But from construction, OQ being parallel to NR ,

$$\alpha = 90 - \theta.$$

Therefore $\cot \theta = \frac{f_2}{f_1} \tan \theta$;

or, $\tan^2 \theta = \frac{f_1}{f_2}$

and $\tan \theta = \sqrt{\frac{f_1}{f_2}}$(16).

The value of θ , as determined from Equations (15) or (16), gives the position of the plane BD on which the stress makes the greatest possible angle with the normal to the plane.

Evidently if the angle GNS is bisected by NM , then NM is the direction of f_1 .

6. Conjugate stresses.

The *obliquity* of a stress is the angle between the direction of the stress, and the normal to the plane upon which it acts.

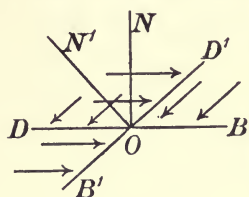

Fig. 10.

Two stresses are said to be *conjugate* when each stress acts upon a plane parallel to the direction of the other. Thus, in Fig. 10, DOB and $D'O'B'$ are two planes, the normals to which are respectively NO and $N'O$. The stress acting on the plane DOB at O is parallel to the plane $D'O'B'$, and its *obliquity* is the angle $D'ON$. If the stress on the plane $D'O'B'$ is parallel to the plane DOB , then its obliquity is the angle $D'ON'$. Thus, the conjugate stresses at any point in a strained solid have equal obliquities.

7. To find the ratio of the intensities of two conjugate stresses whose common obliquity is given. (Fig. 11.)

Let the angle β be the common obliquity; f_1 and f_2 the principal stresses. On the normal OM , set off $ON = \frac{f_1 + f_2}{2}$, and with N as centre, and radius $= \frac{f_1 - f_2}{2}$, describe a semi-circle cutting OM in the points M and S . Draw the line OR^1R , making an angle β with the normal ON , and intersecting the circle at R^1 and R ;

Join RN and R^1N .

Now the two triangles ONR and ONR^1 have each two sides which are the constant components $\frac{f_1 + f_2}{2}$ and $\frac{f_1 - f_2}{2}$ and have the common angle β . Thus OR and OR^1 are conjugate stresses, with a common obliquity β .

Draw the tangent OT and join NT . The angle NOT is the maximum value which the obliquity β can have, and corresponds to the case in which the ratio of the conjugate stresses is unity.

Let ϕ be the maximum value of β .

„ $r = OR$ be the greater of the two conjugate stresses.

„ $r_1 = OR^1$ be the lesser of the two conjugate stresses.

Draw NP perpendicular to and bisecting RR^1 .

$$\sin \phi = \frac{NT}{NO} = \frac{f_1 - f_2}{f_1 + f_2} \dots\dots\dots(17).$$

Now $r + r_1 = OR + OR^1 = 2OP = (f_1 + f_2) \cos \beta$,

and $rr_1 = OR \times OR^1 = OT^2 = ON^2 - NT^2$

$$= \left(\frac{f_1 + f_2}{2}\right)^2 - \left(\frac{f_1 - f_2}{2}\right)^2 = f_1 f_2.$$

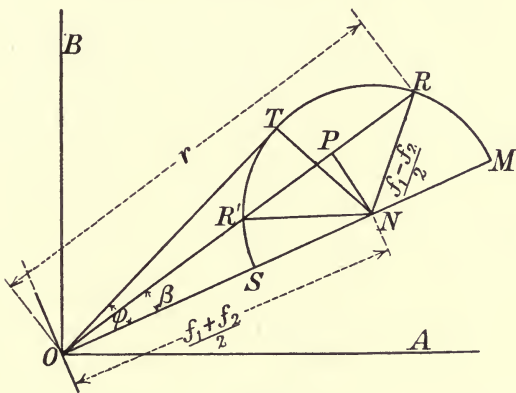

Fig. 11.

Again, since $NP = \left(\frac{f_1 + f_2}{2}\right) \sin \beta$.

Therefore

$$\begin{aligned} PR = PR^1 &= \sqrt{RN^2 - NP^2} = \sqrt{\left(\frac{f_1 - f_2}{2}\right)^2 - \left(\frac{f_1 + f_2}{2}\right)^2 \sin^2 \beta} \\ &= \frac{f_1 + f_2}{2} \sqrt{\left(\frac{f_1 - f_2}{f_1 + f_2}\right)^2 - \sin^2 \beta} = \frac{f_1 + f_2}{2} \sqrt{\sin^2 \phi - \sin^2 \beta} \\ &= \frac{f_1 + f_2}{2} \sqrt{\cos^2 \beta - \cos^2 \phi}. \end{aligned}$$

Hence $r = OP + RP = \frac{f_1 + f_2}{2} (\cos \beta + \sqrt{\cos^2 \beta - \cos^2 \phi})$,

and $r_1 = OP - RP = \frac{f_1 + f_2}{2} (\cos \beta - \sqrt{\cos^2 \beta - \cos^2 \phi})$.

$$\text{Therefore } \frac{r}{r_1} = \frac{\cos \beta + \sqrt{\cos^2 \beta - \cos^2 \phi}}{\cos \beta - \sqrt{\cos^2 \beta - \cos^2 \phi}};$$

$$\text{or, } \frac{r_1}{r} = \frac{\cos \beta - \sqrt{\cos^2 \beta - \cos^2 \phi}}{\cos \beta + \sqrt{\cos^2 \beta - \cos^2 \phi}} \dots\dots\dots(18).$$

The angle β may have any value between zero and ϕ . In the former limit the conjugate stresses are perpendicular to each other and become principal stresses. When the obliquity is the greatest possible, $\beta = \phi$, then R and R^1 coincide in T , and the limit of the ratio of the conjugate stresses becomes unity.

CHAPTER II.

EARTH PRESSURE.

8. Stability of earthwork—Rankine's theory.

Angle of repose.—The slope of a mass of loose dry earth thrown upon a horizontal plane will gradually slip until it finally attains a slope of equilibrium. The greatest inclination of the slope to the horizontal at which the earth will stand permanently is called the angle of repose, and is usually denoted by ϕ .

Angles of Repose.

Earth	Angle of repose ϕ	Weight per cube foot
	Degrees	Lbs.
Sand, dry	28 to 32	} 90 to 118
„ wet	26	
Earth, dry	28	} 100 to 120
„ wet	16	
Clay, dry	29	} 120 to 135
„ damp	18	
Gravel, clean	45	} 90 to 110
„ with sand	30	
Loose shingle	35 to 39	

Coefficient of friction.—In Fig. 12 imagine two small particles of earth pressed together by two normal stresses f , and let q the shear or tangential stress which will *just* cause one particle to slide on the other along the plane of separation.

Then the coefficient of friction

$$\mu = \frac{q}{f}$$

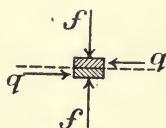

Fig. 12.

In Fig. 13 imagine two masses of earth enclosed, but free to

move along the plane AB . Let these be pressed together by the pressures F (intensity f) inclined to the normal at an angle θ .

F can be resolved into components— $F \cos \theta$ normal to AB and $F \sin \theta$ parallel to AB .

In order that the prism may be in equilibrium there must be a stress q on the vertical faces, the tangential component of which must be equal to that of f , *i.e.* $f \sin \theta$.

With reference to the plane AB the stability is unaffected by q , since its normal components balance one another, and its tangential components are at right angles to AB .

Hence, when slipping is just about to take place, and $\theta = \phi$

$$\mu = \frac{F \sin \phi}{F \cos \phi} = \tan \phi.$$

If the Fig. 13 is turned so that F becomes vertical, and represents the weight of the material, then AB is inclined at the angle of repose (ϕ) to the horizontal.

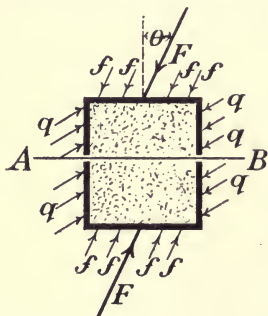

Fig. 13.

At every point in a mass of earth there is a tendency to slip along all planes except the planes of principal stress, and this slipping tendency *increases* with the obliquity of the resultant stress, but is independent of the magnitude of the stress.

9. Condition of equilibrium of a mass of earth.

Earth can only resist compressive forces, consequently the principal stresses at a point in a mass of earth must both be compressive. In

Chapter I., Art. 5, it has been shown that, if f_1 and f_2 be the principal stresses, both of the same sign, f_1 being greater than f_2 , and β be the maximum obliquity of the resultant stress,

then $\sin \beta = \frac{f_1 - f_2}{f_1 + f_2}$, Equation 14, Art. 5,

$$\therefore \frac{f_1}{f_2} = \frac{1 + \sin \beta}{1 - \sin \beta}.$$

But ϕ is the greatest value of β consistent with equilibrium,

$$\therefore \frac{f_1}{f_2} = \frac{1 + \sin \phi}{1 - \sin \phi}.$$

f_1 is the intensity of the vertical pressure.

f_2 is the intensity of the horizontal lateral pressure.

Hence, the necessary condition of equilibrium of a mass of earth is, that the ratio of the greater principal stress to the lesser shall not exceed

$$\frac{1 + \sin \phi}{1 - \sin \phi}.$$

That is,

$$\frac{f_1}{f_2} < \frac{1 + \sin \phi}{1 - \sin \phi},$$

and therefore

$$f_2 > f_1 \frac{1 - \sin \phi}{1 + \sin \phi}.$$

CASE I. . RETAINING WALL WITH A VERTICAL BACK, EARTH HORIZONTAL AND LEVEL WITH TOP OF WALL. (Fig. 14.)

Let H = height of wall.

„ w = weight of cubic foot of earth in lbs.

„ ϕ = angle of repose.

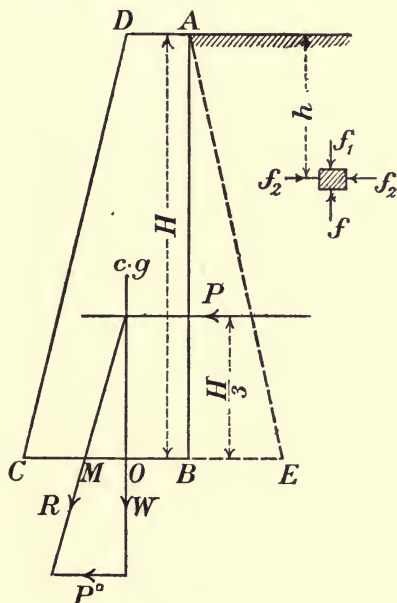

Fig. 14.

Consider one foot of length of the wall. Let h be the depth below the horizontal surface of a small prism of earth. The intensity of vertical pressure f_1 at that depth = wh lbs. Hence the intensity of the horizontal pressure.

$$f_2 = \frac{1 - \sin \phi}{1 + \sin \phi} \times wh \text{ lbs. per sq. ft.}$$

As ϕ is constant, f_2 is proportional to h .

Thus f_2 is zero at top, and increases uniformly to

$$f_2 = \frac{1 - \sin \phi}{1 + \sin \phi} wH \text{ at the bottom.}$$

Therefore the average intensity of pressure on wall

$$= \frac{1 - \sin \phi}{1 + \sin \phi} \frac{wH}{2}$$

and the total horizontal pressure per foot length of wall

$$P = \frac{1 - \sin \phi}{1 + \sin \phi} \cdot \frac{wH^2}{2}.$$

If BE be drawn to represent the horizontal pressure at B , *i.e.*

$$BE = \frac{1 - \sin \phi}{1 + \sin \phi} \cdot wH, \text{ and } E \text{ joined to } A, \text{ then } ABE \text{ gives the}$$

variation of the horizontal thrust. The total pressure P is represented by the area of the triangle ABE , and acts at a point $\frac{H}{3}$ above the base.

Let W = the weight of wall per foot of length, and let its line of action cut the base at O .

Let R , the resultant of P and W cut the base at M .

M must fall within the middle third of base.

Again, taking moments about M .

Since the Moment of Stability must be equal to or greater than the Overturning Moment,

$$W \times OM \text{ must be } \geq P \cdot \frac{H}{3}.$$

$$\text{That is } W \times OM \geq \frac{1 - \sin \phi}{1 + \sin \phi} \frac{wH^3}{6}.$$

CASE II. RETAINING WALL WITH VERTICAL BACK—SURCHARGED. (Fig. 15.)

A wall is said to be surcharged when the earth slopes up from the top of wall. The inclination of the earth to the horizontal cannot, of course, exceed the angle of repose. Let the inclination of earth surcharge = β . Consider a small paralleloiped $LMNO$ with vertical sides at a depth H . The intensity of vertical pressures on the sloping faces LM and NO is

$$r = wH \cos \beta \text{ lbs. per sq. ft.}$$

These pressures being vertical, and parallel to the faces LN and MO , the pressures r_1 on the vertical faces LN and MO must be parallel to LM and NO , that is, parallel to the surface slope.

r and r_1 are conjugate stresses.

In Chapter I., Art. 7, Equation 18, the ratio of the intensities of two conjugate stresses with a common obliquity β was found to be:—

$$\frac{r_1}{r} = \frac{\cos \beta - \sqrt{\cos^2 \beta - \cos^2 \phi}}{\cos \beta + \sqrt{\cos^2 \beta - \cos^2 \phi}}$$

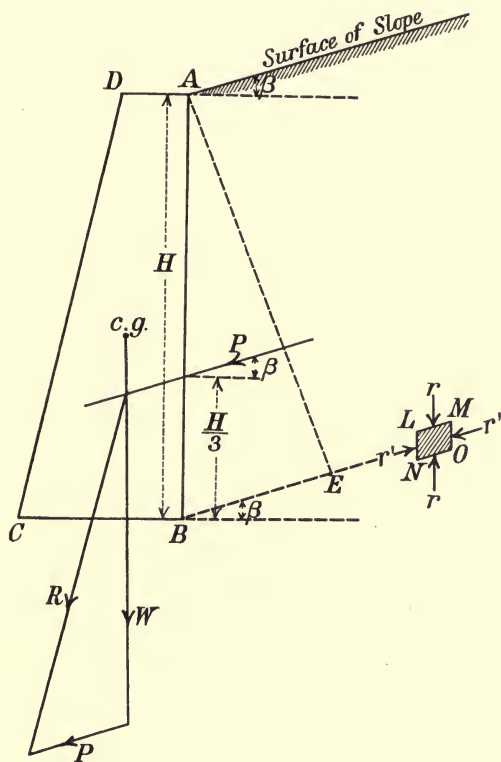

Fig. 15.

NOTE.—When $\beta = \phi$, $r_1 = r$.

Substituting for r its value $wH \cos \beta$.

$$\text{Pressure at base} = wH \cos \beta \cdot \frac{\cos \beta - \sqrt{\cos^2 \beta - \cos^2 \phi}}{\cos \beta + \sqrt{\cos^2 \beta - \cos^2 \phi}}$$

The construction is carried out according to Arts. 5 and 7, Chapter I., the figures of which should be referred to. We know that r the vertical conjugate pressure on a layer at depth $H =$

$wH \cos \beta$. Having got r , $\frac{f_1+f_2}{2}$ and $\frac{f_1-f_2}{2}$ can be got from

Fig. 11, Art. 7, and then the resultant thrust according to Fig. 9, Art. 5. Referring first to Fig. 11, Art. 7, draw BO parallel to the surcharge AM , and at any point O draw OM normal to the plane BO . $OM = H \cos \beta$. Draw OR vertical—that is, making an angle β with OM , and make $OR = OM$, then OR represents the vertical conjugate stress r , which is equal to $wH \cos \beta$. Draw OT making an angle ϕ with OM , and from any point L in OM describe an arc of a circle touching OT and cutting OR in Q . Draw RN parallel to QL , then

$$ON = \frac{f_1+f_2}{2}; \quad NR = \frac{f_1-f_2}{2}$$

Bisect the angle MNR by the line NS , then NS is the direction of the principal axis of ellipse of stress.

To determine the resultant stress at B , refer to Fig. 9, Art. 5. Draw BN_1 normal to the back of wall AB , and draw BG parallel

to NS . Set off $BN_1 = ON = \frac{f_1+f_2}{2}$. From N_1 set off $N_1G = N_1B$

and on N_1G mark off $N_1R_1 = NR = \frac{f_1-f_2}{2}$.

Then R_1B represents the pressure at B , which is equal to $w \times R_1B$.

The resultant thrust $P = \frac{w \cdot R_1B}{2} \cdot H$, is parallel to R_1B , and acts at $\frac{1}{3}H$ above base.

11. Depth of foundations in earth. (Fig. 17.)

Let $H =$ height of wall in feet.

„ $w =$ weight of earth per cubic foot.

„ $w_1 =$ weight of masonry per cubic foot.

„ $t =$ thickness of wall in feet.

„ $\phi =$ angle of repose.

„ $d =$ required depth of foundation.

When the wall has just stopped subsiding and the earth on each side is just on the point of heaving up, f_1 will be a maximum.

Therefore immediately below the wall we have

$$f_2 = f_1 \frac{1 - \sin \phi}{1 + \sin \phi}$$

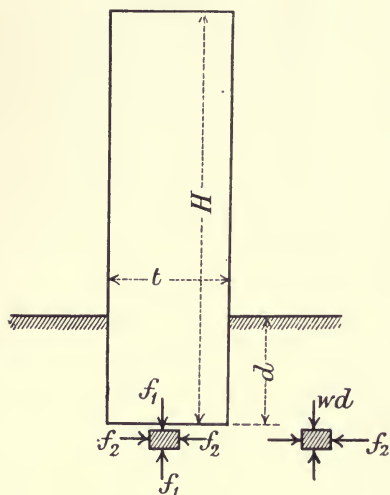

Fig. 17.

At the same level outside the foundation the horizontal pressure is a maximum, since the earth is on the point of heaving up.

$$\therefore wd = f_2 \frac{1 - \sin \phi}{1 + \sin \phi},$$

$$\therefore wd = f_1 \left(\frac{1 - \sin \phi}{1 + \sin \phi} \right)^2.$$

Now, considering one foot length of wall,

$$f_1 = \frac{w_1 H t}{t},$$

$$\therefore d = \frac{w_1 H}{w} \left(\frac{1 - \sin \phi}{1 + \sin \phi} \right)^2 \text{ feet,}$$

or if W = weight of wall per foot run

$$d = \frac{W}{wt} \left(\frac{1 - \sin \phi}{1 + \sin \phi} \right)^2 \text{ feet.}$$

EXAMPLES.

1. A retaining wall 14 feet high, with vertical back, of the section shown in Fig. 18, has to support a bank of earth the upper surface of which is horizontal and level with the top of wall. Determine the total pressure on one foot length of wall, also the direction of the resultant pressure on base.

The earth weighs 120 lbs. per cubic foot, and its angle of repose is 27° . The masonry weighs 140 lbs. per cubic foot.

$$f_1 = 14w = 14 \times 120 = 1680 \text{ lbs. per sq. ft.}$$

$$f_2 = f_1 \frac{1 - \sin \phi}{1 + \sin \phi} = 1680 \cdot \frac{0.546}{1.454} = 630.8 \text{ lbs. per sq. ft.}$$

$$\text{Average pressure} = \frac{f_2}{2} = 315.4 \text{ lbs. per sq. ft.}$$

$$\text{Total pressure } P = 315.4 \times 14 = 4416 \text{ lbs.}$$

$$\text{Weight of wall } W = 9 \times 7 \times 140 = 8820 \text{ lbs.}$$

The resultant R is got by compounding P and W ; it cuts the base within the middle third.

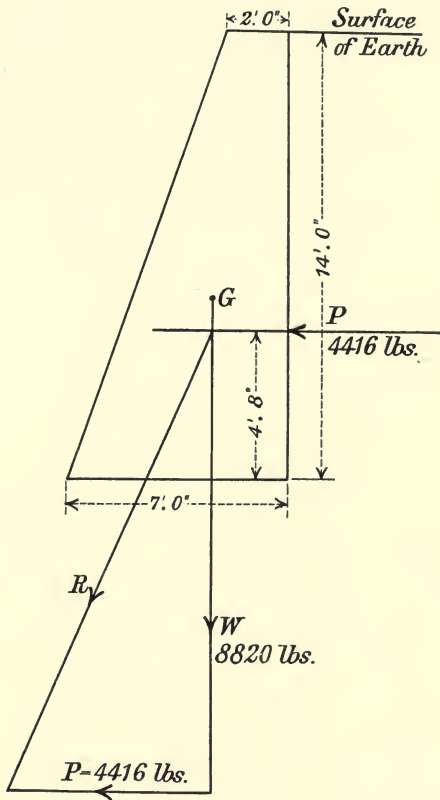

Fig. 18.

2. A retaining wall 20 feet high, with vertical back, of cross section as in Fig. 19, sustains an embankment of earth, the angle of surcharge being 20° . Weight of masonry 140 lbs. per cubic foot; weight of earth 120 lbs. per cubic foot; angle of repose 30° . Find the total thrust on the wall and the resultant pressure on the base.

Weight of wall $W = 12 \times 10 \times 140 = 16800$ lbs.

Data— $\beta = 20^\circ$; $\phi = 30^\circ$.

$w = 120$ lbs.; $H = 20$ feet.

$r = wH \cos \beta = 2078.4$ lbs. per sq. ft.

Now r_1 the conjugate pressure parallel to surface slope is got from Equation 18, Art. 7:—

$$\begin{aligned} \frac{r_1}{r} &= \frac{\cos \beta - \sqrt{\cos^2 \beta - \cos^2 \phi}}{\cos \beta + \sqrt{\cos^2 \beta - \cos^2 \phi}} \\ &= \frac{0.94 - 0.366}{0.94 + 0.366} = 0.44. \end{aligned}$$

$$\therefore r_1 = 2078.4 \times 0.44 = 914.5 \text{ lbs. per sq. ft.}$$

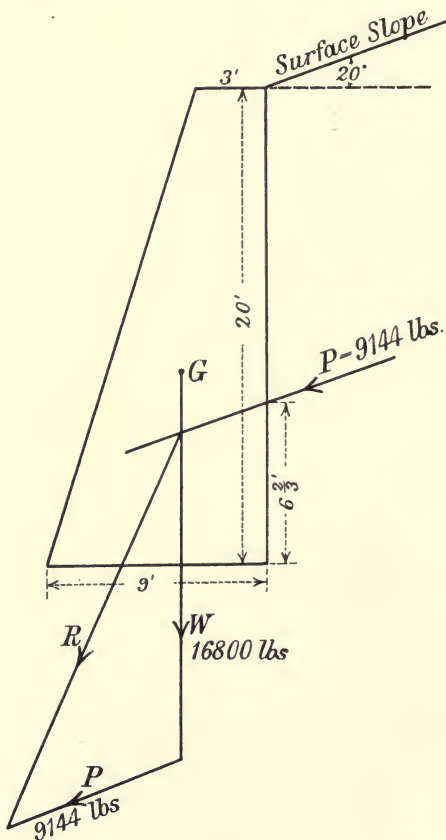

Fig. 19.

Average conjugate stress = 457.2 lbs. per sq. ft.

Total thrust per foot length of wall, parallel to the surcharge, is

$$P = 457.2 \times 20 = 9144 \text{ lbs.}$$

The resultant R got by compounding P and W cuts the base within the middle third.

3. A masonry wall weighing 140 lbs. per cubic foot is 24 feet high and 3 feet thick. The earth in foundation weighs 120 lbs. per cubic foot and the angle of repose is 30° . Determine the least depth of the foundation.

Take one foot in length of wall.

Let d = required depth of foundation.

f_1 = intensity of vertical pressure at bottom of foundation.

$$= \frac{24 \times 3 \times 140}{3} = 3360 \text{ lbs. per sq. ft.}$$

Intensity of vertical pressure at same depth outside the foundation—

$$= 120d;$$

$$\text{but} \quad \frac{120d}{f_1} = \left(\frac{1 - \sin \phi}{1 + \sin \phi} \right)^2.$$

$$\therefore \frac{120d}{3360} = \frac{1}{9}.$$

$$\therefore d = 3.1 \text{ feet.}$$

4. A concrete pillar 12 feet high and 3 feet square rests on base of concrete 5 feet square and 2 feet thick, and carries a load of 32 tons on top. Find the least depth of foundation necessary for a foundation in earth weighing 120 lbs. per cubic foot, the angle of repose being 28° .

Weight of concrete 150 lbs. per cubic foot.

The concrete pillar and base weighs

$$158 \times 150 = 23700 \text{ lbs.} = 10.5 \text{ tons.}$$

\therefore Total weight on bottom of foundation = 42.5 tons.

f_1 = intensity of vertical pressure at bottom of foundation

$$= \frac{42.5 \times 2240}{25} = 3808 \text{ lbs. per sq. ft.}$$

w_d = intensity of vertical pressure at same level but outside foundation

$$= 120 d.$$

$$\therefore \frac{120 d}{3808} = \left(\frac{1 - \sin \phi}{1 + \sin \phi} \right)^2 = 0.14.$$

$$d = \frac{3808}{120} \times 0.14 = 4.5 \text{ feet.}$$

5. *Example of retaining wall worked out from ellipse of stress according to Art. 10.*

A retaining wall, ABCD (Fig. 20), 20 feet high, with vertical back, is surcharged with earth, the surface slope being inclined at 20° . Determine the magnitude and direction of the resultant thrust on wall and the maximum intensity of pressure on the base.

Let top width = 2 feet. Bottom width = $\frac{4}{10} \cdot 20 = 8$ feet.

Weight of masonry per cubic foot = 140 lbs.

Weight of earth per cubic foot = 120 lbs.

Angle of repose of earth = $\phi = 32^\circ$.

The wall has been taken with vertical back so as to be slightly different from Art. 10, in which the back was sloping. The construction is the same.

Draw BO parallel to the surface slope. At any point O in BO draw OM perpendicular to BO . Draw OR vertical—that is, making an angle of 20° with OM , and make $OR = OM$. Draw OT , making an angle $\phi = 32^\circ$ with OM . At any point L in OM draw an arc tangent to OT , cutting OR in Q , join LQ , and draw RN parallel to LQ , meeting OM in N . Bisect the angle MNR by NS , then NS in the direction of the principal axis of stress.

Now draw BN_1 normal to back of wall and equal to ON , draw BG parallel to NS , and make $N_1G = BN_1$. Join N_1G , and make $N_1R_1 = NR$. Join R_1B , then R_1B represents the thrust at B in magnitude and direction. By scale $R_1B = 8$.

\therefore Thrust at $B = w \cdot R_1B = 120 \times 8 = 960$ lbs.,

and resultant thrust $P = \frac{w \cdot R_1B}{2} H$

$$= \frac{960}{2} \cdot 20 = 9600 \text{ lbs.}$$

$$= 4.3 \text{ tons,}$$

acting parallel to R_1B at a point $\frac{H}{3}$ above the base.

Weight of wall per foot run—

$$W = 5 \times 20 \times 140 = 14000 \text{ lbs.} = 6.25 \text{ tons.}$$

Compounding P and W we get R , the resultant thrust on base BC in magnitude and direction. This resultant cuts the base at the middle third nearest C , and its component normal to the base is 8 tons by scale.

The maximum stress at *C* is therefore by Art. 19, Chapter III.

$$\begin{aligned}
 f_1 &= \frac{2N}{\text{area of base}} \\
 &= \frac{2 \times 8}{8} = 2 \text{ tons per sq. ft.}
 \end{aligned}$$

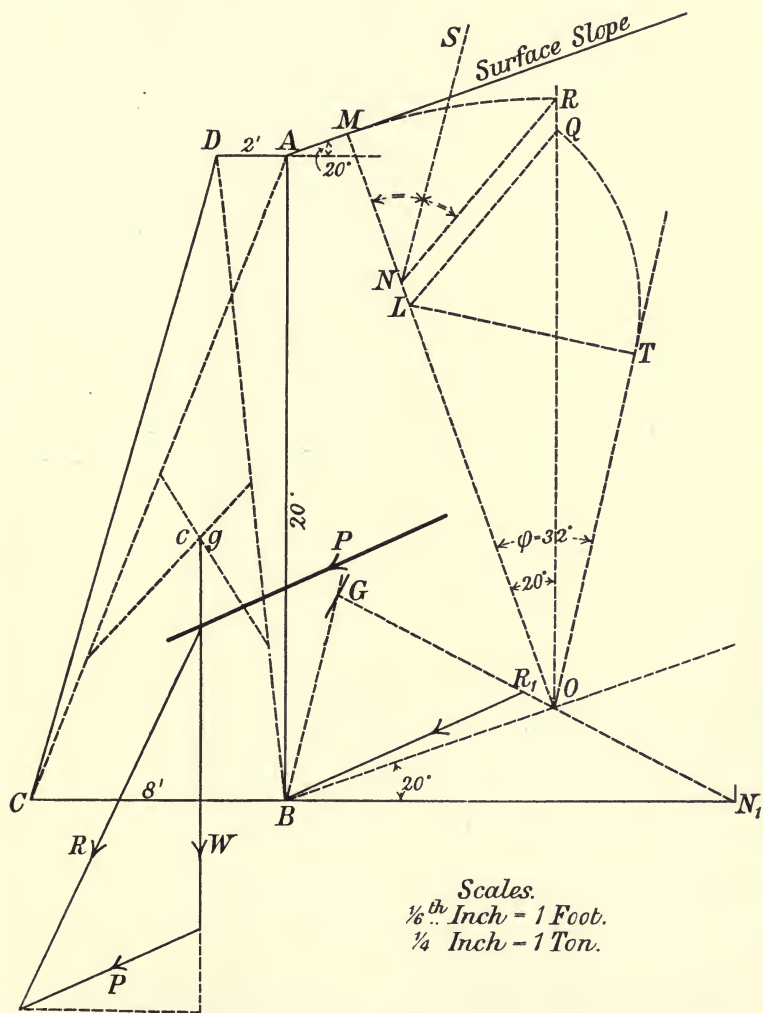

Fig. 20.

12. Wedge theory.

Suppose a mass of earth supported by a wall AB . If the wall be removed a wedge or prism of earth ABC will fall away, and ultimately take a slope BD , making an angle ϕ (the angle of repose of the earth) with the horizontal. (Fig. 21.)

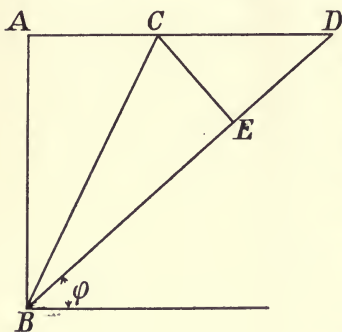

Fig. 21.

The prism ABD , if it were in one mass, will be in equilibrium without exerting any pressure on AB , because its tendency to slip down BD would be resisted by the friction of the surface.

If we take a prism ABC , the surface BC being inclined at an angle greater than ϕ , it will exert a pressure on the wall due to its weight, diminished by the friction on slope BC . A smaller prism than BAC will obviously exert less pressure, so that there must be some prism or wedge between AB and BD for which the pressure on the back of the wall is a maximum. It will be now proved that this maximum pressure occurs when the triangle $BAC =$ triangle BCE , where CE is at right angles to BD . If the back of the wall is not vertical AB is taken as a vertical plane at right angles to the plane of the paper.

13. Maximum earth thrust. Plane of rupture.

The algebraic determination of the maximum horizontal thrust is tedious, but the graphic application of the result is very simple.

Let Fig. 22 represent a retaining wall surcharged with earth sloping at an angle less than the angle of repose. Let $\phi =$ angle of repose, and θ the angle which plane of rupture makes with the natural slope of the earth BD . Considering the equilibrium of the wedge or prism BAC , the three forces acting on it are :

(1) W , the weight of the wedge ABC acting at its centre of gravity.

(2) The reaction P , which is equal to the pressure on the wall, acting at $\frac{AB}{3}$ from B . This pressure is assumed horizontal as the friction on AB is neglected.

(3) The reaction R_1 of the plane BC making an angle ϕ with the normal HN , and from the figure it can be seen that it makes an angle θ with the direction of W .

From the triangle of forces $P = W \tan \theta$.

\therefore Maximum horizontal thrust is

Area of triangle $ABC \times \tan \theta \times w$,

where $w =$ weight of cubic foot of earth.

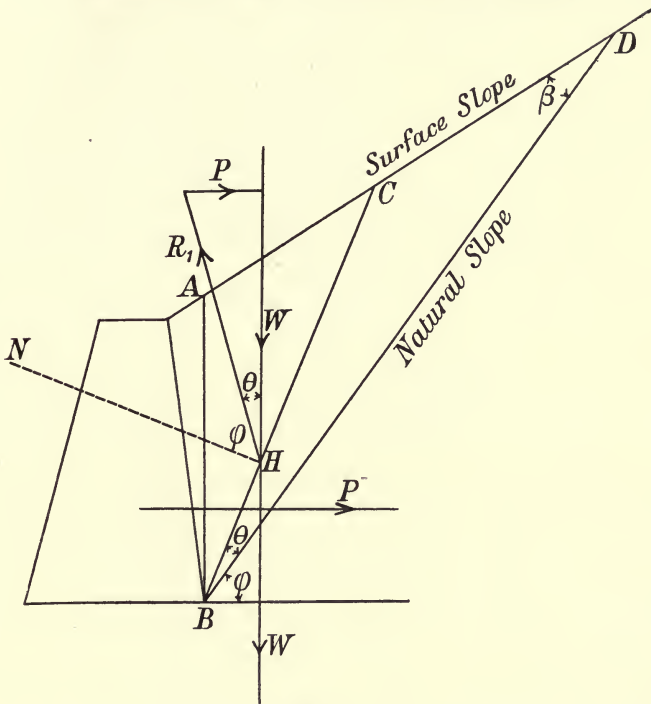

Fig. 22.

In Fig. 23 draw the triangles ABC and ABD . From A and C draw AF , CE perpendicular to BD , and draw BG also perpendicular to BD , to meet DA the surface slope produced in G .

Let $BG = c$, $BD = b$, $AF = a$, $CE = x$, which varies with θ .

Let angle $ADB = \beta$.

Then the horizontal thrust on $AB = w \times \text{area } ABC \times \tan \theta$

$$= w \left(\frac{ab}{2} - \frac{xb}{2} \right) \tan \theta = \frac{wb}{2} \cdot \frac{ax - x^2}{b - x \cot \beta}$$

Differentiating for a maximum—

$$(b - x \cot \beta) (a - 2x) + (ax - x^2 \cot \beta) = 0.$$

$$\therefore x^2 \cot \beta - 2bx - ab = 0 \dots\dots\dots(1).$$

This equation may be written :

$$ab - bx = x(b - x \cot \beta) = x \cdot BE.$$

That is, the triangle $BAC =$ the triangle BCE .

Hence, the horizontal earth thrust is a maximum when the area $BAC =$ area BCE .

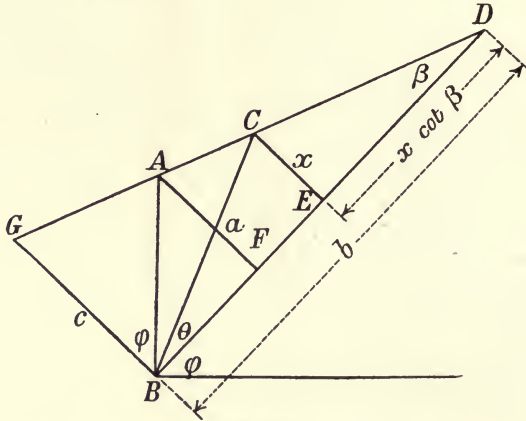

Fig. 23.

$$\begin{aligned} \text{Now, horizontal earth thrust} &= w \times \text{area } ABC \tan \theta \\ &= w \times \text{area } BCE \tan \theta \\ &= w \times \frac{x \cdot BE}{2} \times \frac{x}{BE} \\ &= \frac{wx^2}{2} \dots \dots \dots (2). \end{aligned}$$

Solving Equation (1) for x , we get

$$x = \frac{b - \sqrt{b^2 - ab \cot \beta}}{\cot \beta}.$$

The minus sign being taken, since $x \cot \beta$ cannot be greater than b . But $\cot \beta = \frac{b}{c}$.

\therefore Maximum horizontal thrust from (2)

$$P = \frac{w}{2} \{c - \sqrt{c(c-a)}\}^2.$$

According to Dr. Scheffler's theory the direction and magnitude of the thrust is modified by the friction on the plane AB . If the coefficient of friction = $\tan \phi$, then the component of

friction = $P \tan \phi$, and the resultant pressure on the vertical plane by his theory is represented by $P_1 = P \sec. \phi$ (Fig. 24).

The following formula for the maximum horizontal earth pressure on a vertical wall based on the Wedge Theory is proved in 'Strength and Elasticity of Structural Members' (Woods). It is easy of application and friction is taken into account — μ is the coefficient of friction for earth on earth and is assumed the same for earth on masonry.

Surface of earth level with top of wall :

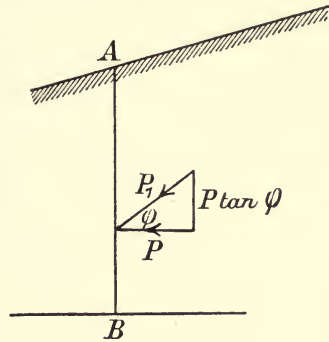

Fig. 24.

$$\text{Max. } P = \frac{wh^2}{2} \frac{1 + 3\mu^2 - 2\mu\sqrt{2(\mu^2 + 1)}}{(1 - \mu^2)^2}$$

14. To find the resultant pressure on the base of a retaining wall in magnitude, direction, and position, friction being taken into account.

Let t be the thickness of base (Fig. 25).

„ h be the height of wall.

„ d be the distance of the point where the resultant cuts the base from the outer edge of base.

„ P be the maximum pressure of the earth on wall acting at a height $\frac{h}{3}$ above base.

„ W_1 be the weight of the wall.

„ R be the resultant pressure on base of wall.

„ a be the angle which the direction of resultant makes with horizontal.

„ b be the distance of line of action of W_1 from outer edge of base.

„ μ be the coefficient of friction.

Then resolving horizontally and vertically,

$$R \cos a = P,$$

$$R \sin a = W_1 + \mu P.$$

Therefore $R^2 = P^2 + (W_1 + \mu P)^2 \dots \dots \dots (3),$

and $\tan a = \frac{W_1 + \mu P}{P} \dots \dots \dots (4).$

Taking moments about outer edge of base,

$$Rd \sin a = W_1 b + \mu Pt - P \frac{h}{3}$$

Therefore
$$d = \frac{W_1 b + \mu Pt - P \frac{h}{3}}{W_1 + \mu P} \dots\dots\dots (5).$$

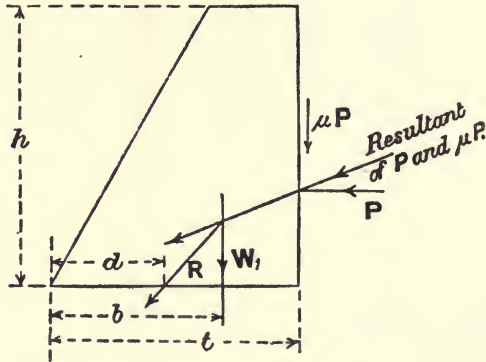

Fig. 25.

Equations (3), (4), (5) give the magnitude, direction, and position of the resultant pressure.

15. Graphic method of determining the earth thrust from wedge theory.

CASE I. SURFACE OF EARTH HORIZONTAL.

In Fig. 26 draw *BG* perpendicular to the natural slope of earth

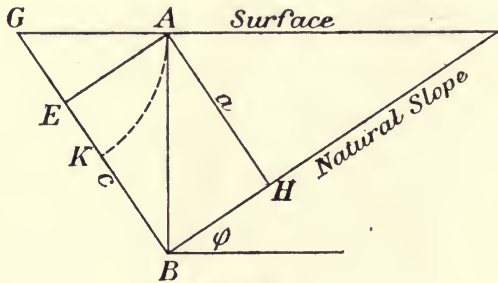

Fig. 26.

to meet the surface produced at *G*. With centre *G*, and radius *GA*, describe the arc *AK*, then

$$BK = c - \sqrt{c(c-a)}.$$

Draw AE perpendicular to GB , then

$$GK^2 = GA^2 = BG \times GE;$$

but

$$BG = c, \text{ and } GE = c - a,$$

$$\therefore GK = \sqrt{c(c-a)},$$

and

$$BK = c - \sqrt{c(c-a)}.$$

Hence

$$P = \frac{1}{2} w BK^2.$$

CASE II. SURCHARGED RETAINING WALL, THE SURFACE SLOPING AT AN ANGLE LESS THAN ϕ .

Draw a perpendicular from B to the natural slope, meeting the surface slope produced at G (Fig. 27). On BG describe a

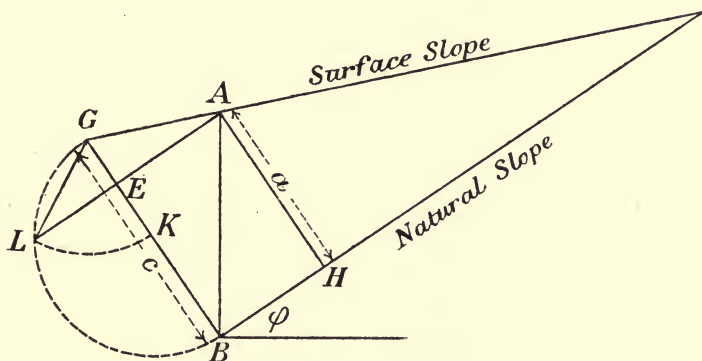

Fig. 27.

semi-circle. From A draw a perpendicular AEL to GB , cutting the semi-circle at L . With centre G , and radius GL , describe the arc LK cutting GB at K .

$$\text{Then } GK = GL = \sqrt{GB \times GE} = \sqrt{c(c-a)}.$$

$$\therefore BK = c - \sqrt{c(c-a)}.$$

Hence

$$P = \frac{w}{2} BK^2.$$

CASE III. SURCHARGED RETAINING WALL, THE SURFACE SLOPING AT AN ANGLE ϕ .

Fig. 28 represents this case, and we see that $c = a$; therefore $c - a = 0$.

$$\therefore c - \sqrt{c(c-a)} = c = BK.$$

Hence

$$P = \frac{w}{2} BK^2.$$

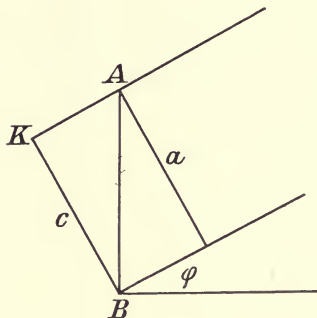

Fig. 28.

EXAMPLE.

Design a retaining wall 18 feet high, built of masonry weighing 140 lbs. per cubic foot. The weight of the earth is 120 lbs. per cubic foot, and the angle of repose 28° .

Assume a cross section for the wall $DBCE$ as in Fig. 29, the width at the top being 2 feet and at the base 8 feet.

The graphic construction for earth thrust is drawn according to Case II., and BK by scale measures 12.5 feet.

$$\begin{aligned} \therefore P &= \frac{w}{2} BK^2 = \frac{120}{2} \times 12.5^2 \\ &= 9375 \text{ lbs.} = 4.18 \text{ tons,} \end{aligned}$$

and

$$P_1 = P \sec. 28^\circ = 4.72 \text{ tons.}$$

$$\begin{aligned} \text{Weight per foot run of masonry acting at } S \\ &= 12600 \text{ lbs.} = 5.6 \text{ tons.} \end{aligned}$$

$$\begin{aligned} \text{Weight per foot run of earth wedge } DBA \\ &= 2280 \text{ lbs.} = 1.02 \text{ ton acting at } T. \end{aligned}$$

The total weight $W = 6.62$ tons acting at O the common centre of gravity.

Compounding P_1 and W , we find the direction and magnitude of R the resultant pressure on the base. It cuts the base within the middle third, the distance from the centre of base to centre of pressure being 1 foot.

$$R = 9.8 \text{ tons.}$$

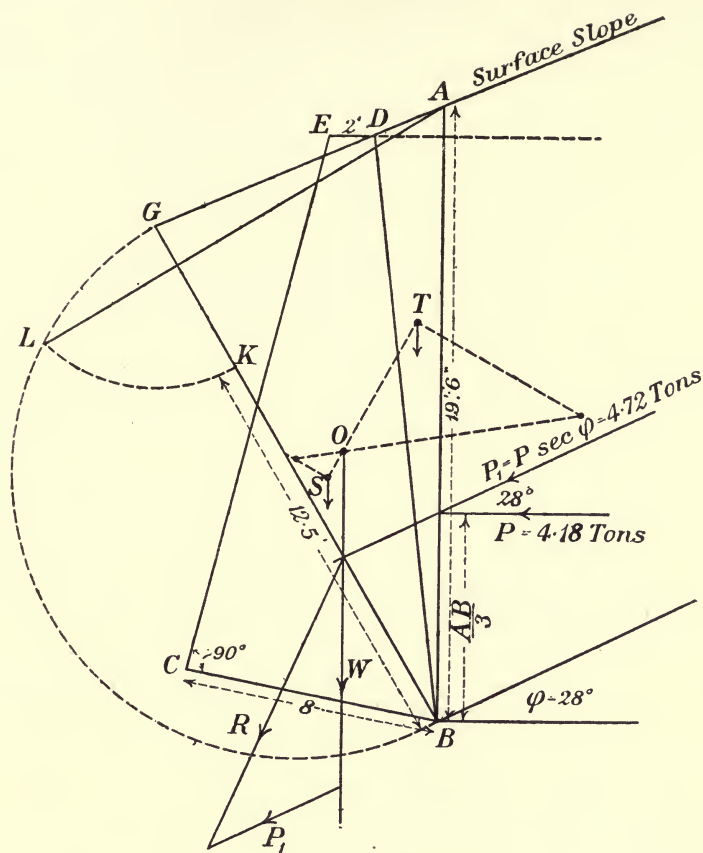

Scales
 $\frac{1}{6}^{th}$ Inch - 1 Foot
 $\frac{1}{6}^{th}$ Inch - 1 Ton.

Fig. 29.

Its component normal to the base = 9.4 tons.
 The maximum intensity of pressure at C by Equation 5, Art. 16—

$$f_1 = \frac{9.4}{8} + \frac{9.4 \times 1 \times 4}{\frac{1 \times 8^3}{12}}$$

$$= 1.17 + 0.9 = 2.07 \text{ tons per sq. ft.}$$

CHAPTER III.

STRESSES DUE TO ECCENTRIC LOADS—STABILITY OF MASONRY STRUCTURES.

STRESS AT A PLANE SECTION DUE TO NON-AXIAL LOADS.

16. Stress on a section or joint, the load being eccentric or non-axial.

Let AB (Fig. 30) represent the trace of a section on a plane at right angles to it, O being that of a line through its centre of area. Let F be the resultant force normal to the section, its line of action intersecting AB in N . The point of application of F must be on a centre line of the cross section. F is also the resultant *internal stress* developed at AB .

Let $ON = x_0$; that is, the distance from centre of area to centre of stress, commonly called the 'eccentricity' or 'deviation' of the load.

„ x_1 and x_2 be the distances from O to B and A respectively.

„ $A =$ area of the surface AB .

„ f_1 and f_2 be the intensities of stress at B and A respectively.

„ $I =$ the moment of inertia of the section about an axis through O at right angles to the plane of the figure, —that is, *at right angles to the plane containing the centre of area and point of application of load.*

„ $k =$ the corresponding radius of gyration.

Now the force F at N is equivalent to an equal F at O , and a couple whose moment is $M = Fx_0$.

(a) The intensity of stress due to F acting at centre of area O is $\frac{F}{A}$, uniformly distributed over the section.

(b) The intensity of the uniformly varying stress due to the bending moment $M = Fx_0$ on any line distant x from O is $\frac{Fx_0x}{I}$. At the edge B this = $\frac{Fx_0x_1}{I}$; and at $A = \frac{Fx_0x_2}{I}$. By the

principle of superposition the resultant stress is the algebraic sum of these two intensities. Compressive and tensile stresses are regarded as positive and negative respectively.

Hence, adding (a) and (b) we get :

Intensity of stress at edge B—

$$f_1 = \frac{F}{A} + \frac{Fx_0x_1}{I} \dots\dots\dots(1)$$

$$= \frac{F}{A} \left(1 + \frac{x_0x_1}{k^2} \right) \dots\dots\dots(2).$$

Intensity of stress at edge A—

$$f_2 = \frac{F}{A} - \frac{Fx_0x_2}{I} \dots\dots\dots(3)$$

$$= \frac{F}{A} \left(1 - \frac{x_0x_2}{k^2} \right) \dots\dots\dots(4).$$

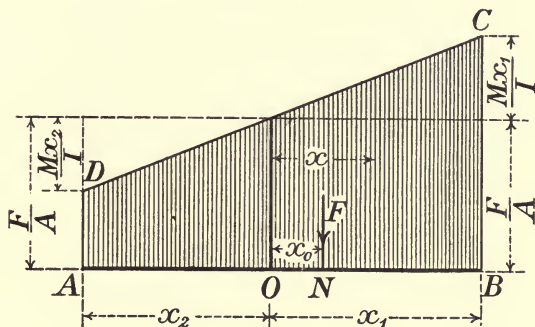

Fig. 30.

The distribution of stress is shown graphically in Fig. 30. The ordinates from AB are proportional to the stress at any point in the section. The maximum compressive stress is the ordinate BC at the edge B of the section nearest to the applied force F.

In symmetrical sections $x_1 = x_2$; and Equations (1) and (3) become

$$f_1 = \frac{F}{A} + \frac{Fx_0x_1}{I} \dots\dots\dots(5).$$

$$f_2 = \frac{F}{A} - \frac{Fx_0x_1}{I} \dots\dots\dots(6).$$

In any example the stresses f_1 and f_2 are compressive or tensile according as the results are positive or negative.

In the above the force F was a thrust. If the force is a pull or tensile then write $-F$ for F , and as before f_1 and f_2 will be tensile if negative and compressive if positive.

For a pulling force equations (5) and (6) become

$$f_1 = -\left(\frac{F}{A} + \frac{Fx_0x_1}{I}\right) \dots\dots\dots(7).$$

$$f_2 = +\frac{Fx_0x_1}{I} - \frac{F}{A} \dots\dots\dots(8).$$

If the resultant of the loading forces is a force R inclined to the section or joint, then F in the above equations is the component of R normal to AB .

The force F may act outside the section, as in a curved braced crane with suspended weight, or as in the case of a vertical post with fixed horizontal bracket which carries the load.

17. Strength reduced by non-axial loading.

The strength of a member depends on the *maximum*, not on the mean intensity of stress; hence the strength is reduced if the load is non-axial, owing to the unequal distribution of stress, in the ratio of the mean intensity of stress to the maximum intensity of stress—that is, in the ratio of

$$\begin{aligned} & \frac{F}{A} \\ & \frac{F}{A \left(1 + \frac{x_0x_1}{k^2}\right)} \\ & = \frac{1}{1 + \frac{x_0x_1}{k^2}}, \end{aligned}$$

and the safe working load is reduced in the same proportion for a deviation x_0 from the centre of area.

18. Neutral axis of stress.

With a non-axial load the distribution of stress is assumed to be a *uniformly varying* one—that is, the intensity of stress at any point in the section varies directly as the distance of that point from a fixed line in the plane of the section. This line is called the *neutral axis of the stress*, because at all points of that axis the normal intensity of stress is zero. In Fig. 30 the neutral axis of the stress lies beyond the boundary of the section, and the stress is of one sign all over the surface. If the neutral axis,

as in Fig. 31, falls within the section, it divides the section into two parts, on one of which there is tension and on the other compression. The ordinates of the shaded figure are proportional to the stress at any point in the section.

$$\begin{aligned} \text{Max. compressive stress } f_1 &= \frac{F}{A} + \frac{Mx_1}{I} \\ &= \frac{F}{A} \left(1 + \frac{x_0 x_1}{k^2} \right) \dots \dots \dots (9). \end{aligned}$$

$$\begin{aligned} \text{Max. tensile stress } f_2 &= \frac{Mx_2}{I} - \frac{F}{A} \\ &= \frac{F}{A} \left(\frac{x_0 x_2}{k^2} - 1 \right) \dots \dots \dots (10). \end{aligned}$$

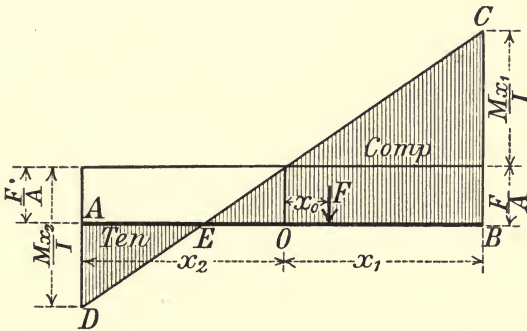

Fig. 31.

The position of the neutral axis or the point where the reversal of stress takes place is determined by the value of x_2 , which makes $f_2 = 0$ in Equations (4) or (10).

Thus let $x_n = OE$, Fig. 31.

Then for $f_2 = 0$,

$$\frac{x_0 x_n}{k^2} = 1,$$

or
$$x_n = \frac{k^2}{x_0} \dots \dots \dots (11).$$

19. Limiting value of x_0 , without reversing the sign of the stress.

It is necessary, especially in the case of masonry joints, to limit the value of x_0 , in order to ensure that at no part of the joint will the stress be tensile, as unaided by the introduction of steel no masonry joint can be depended on to resist tension.

This limiting value of x_0 is found by equating f_2 in Equation (6) to zero—

Or
$$\frac{F}{A} - \frac{Fx_0x_1}{I} = 0,$$

$$\therefore x_0 = \frac{I}{Ax_1} \dots\dots\dots(12).$$

RECTANGULAR JOINT.—Let Fig. 32 represent a rectangular section, with sides whose lengths are t and l parallel to OX and OY respectively.

Then $A = lt, x_1 = \frac{t}{2}, I_{YY} = \frac{lt^3}{12},$

where I_{YY} is the Moment of Inertia of section about axis through O perpendicular to XX containing the centre of area O , and N the point of application of load.

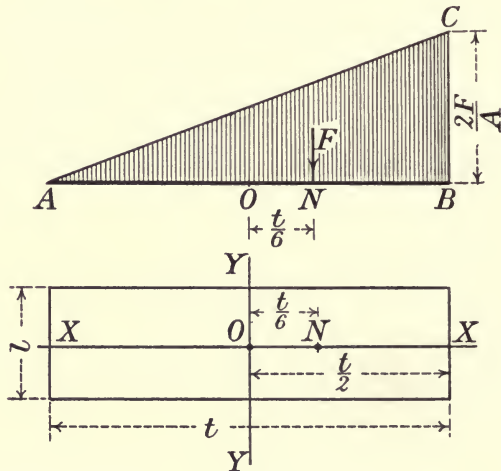

Fig. 32.

From (12)—

Limiting value of $x_0 = \frac{lt^3}{12 \times lt \times \frac{t}{2}}$
 $= \frac{t}{6} \dots\dots\dots(13).$

As x_0 may be on either side of O , we have from (13) that the resultant thrust must fall within the middle third of the joint in order that there may be no tensile stress on any part of the joint.

When $x_0 = \frac{t}{6}$, the value of the intensity of stress varies from $2\left(\frac{F}{A}\right)$ at the edge nearest the resultant to zero at the opposite edge (Fig. 32).

Again, when $x_0 = \frac{t}{3}$, the distance of N , the centre of pressure, from the nearest edge of section parallel to OY is

$$d = \frac{t}{3}.$$

If d is less than $\frac{t}{3}$, then a part only of the joint is available to resist pressure, and the breadth of this useful part is (Fig. 33)

$$t_1 = 3d,$$

and Equations (5) and (6) apply only to that part of the joint whose breadth is t_1 , x_0 and x_1 in these equations being then measured from an axis distant $\frac{t_1}{2}$ from the edge nearest F . So that, when $d < \frac{t}{3}$, that part of the area of joint to which (5) and (6) apply is

$$A_1 = 3dl,$$

and the maximum intensity of stress is

$$f_1 = 2 \frac{F}{A_1} \dots (14).$$

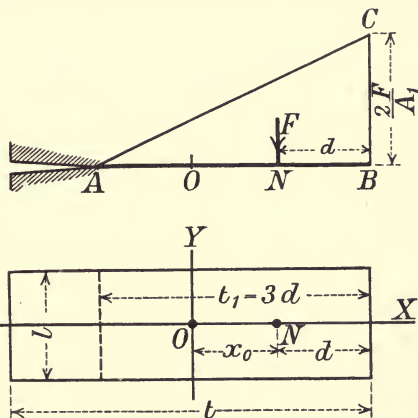

Fig. 33.

CIRCULAR SECTION.

Let D = diameter. Then for this section

$$A = \frac{\pi D^2}{4}, \quad x_1 = \frac{D}{2}, \quad I = \frac{\pi D^4}{64}.$$

Therefore by equation (12) $x_0 = \frac{D}{8} \dots \dots \dots (15).$

Hence the limit of deviation of the point of application of the resultant force from the centre to ensure stress of the same sign all over the circular section is $\frac{D}{8}$.

In a *hollow circular section* of outside diameter D and inside diameter D_1 the limit of deviation is

$$x_0 = \frac{D^2 + D_1^2}{8D} \dots\dots\dots(16).$$

20. Extreme intensities of stress for a rectangular section in terms of d , the distance of the centre of stress from the nearest edge of section.

The position of the centre of stress N is sometimes given by its distance from the nearest edge of the section or joint.

Let F = resultant normal pressure.

„ t = breadth of joint AB .

„ d = distance of centre of stress N from the edge B .

„ f_1 and f_2 the extreme intensities of stresses at edges B and A respectively.

From Equation (2), Art. 16,

$$f_1 = \frac{F}{A} \left(1 + \frac{x_0 x_1}{k^2} \right).$$

If the width of the joint at right angles to AB be unity,

Then $x_0 = \frac{t}{2} - d; x_1 = \frac{t}{2}; k^2 = \frac{t^2}{12}; A = 1 \times t.$

Therefore
$$f_1 = \frac{F}{A} \left(1 + \frac{\left(\frac{t}{2} - d \right) \frac{t}{2}}{\frac{t^2}{12}} \right)$$

$$= \frac{2F}{t} \left(2 - \frac{3d}{t} \right) \dots\dots\dots(17).$$

And
$$f_2 = \frac{F}{A} \left(1 - \frac{\left(\frac{t}{2} - d \right) \frac{t}{2}}{\frac{t^2}{12}} \right)$$

$$= \frac{2F}{t} \left(\frac{3d}{t} - 1 \right) \dots\dots\dots(18).$$

Let f be the average stress-intensity on the section—that is, $\frac{F}{t}$, then from (17)—

$$f_1 = 2f \left(2 - \frac{3d}{t} \right),$$

or
$$d = \frac{t}{3} \left(2 - \frac{f_1}{2f} \right) \dots\dots\dots(19).$$

Equation (19) gives the value of d , the *distance of the centre of pressure from the edge of section, where f_1 is the maximum stress-intensity, and f is the average stress-intensity on the section.*

As before, we get the limiting value of d , so that there shall be no tension on the section, but putting $f_2 = 0$.

To fulfil this condition we must have

$$d = \frac{t}{3}.$$

EXAMPLES.

1. A short T-iron, $5'' \times 4'' \times \frac{1}{2}''$, supports a thrust normal to the cross section of 10 tons acting at a distance of $\frac{3}{4}$ inch from the centre of area on the opposite side to flange. The point of application of thrust is on the centre line of the vertical leg. Determine the maximum and minimum intensities of stress.

Since the centre of area and point of application of load lie in the centre plane of the leg, we must use the moment of inertia about an axis through centre of area perpendicular to this plane—that is, parallel to the flange. Call this axis XX .

Then $I_{XX} = 5.77$ inch units ; $A = 4.25$ sq. in.

$$x_0 = \frac{3}{4} \text{ inch ; } F = 10 \text{ tons.}$$

The distance of the centre of area from upper edge of flange = 1.05 in.

$$\therefore x_2 = 1.05, \text{ and } x_1 = 4 - 1.05 = 2.95 \text{ in.}$$

From Equation (1). Intensity of stress at outer edge of leg—

$$\begin{aligned} f_1 &= \frac{F}{A} + \frac{Fx_0x_1}{I} \\ &= \frac{10}{4.25} + \frac{10 \times \frac{3}{4} \times 2.95}{5.77} \\ &= 2.35 + 3.8 = +6.15 \text{ tons per sq. in. compressive.} \end{aligned}$$

From Equation (3). Intensity of stress at upper edge of flange—

$$f_2 = 2.35 - 3.8 = -1.5 \text{ ton per sq. in. tensile.}$$

2. A short piece of I-beam, $12'' \times 6''$, weighing 44 lbs. per foot run, sustains a normal thrust of 50 tons acting at a distance of $1\frac{1}{2}$ in. from the centre of area on the centre line of the web. Determine the maximum and minimum intensities of stress.

The Moment of Inertia about axis through centre of area parallel to flange = 315.3 inch units.

$$A = 12.94, \text{ hence } k^2 = 24.3.$$

$$x_0 = 1\frac{1}{2} \text{ in. ; } x_1 = x_2 = 6 \text{ in.}$$

From Equation (2).

Maximum intensity of stress at outer edge of flange nearest the load—

$$\begin{aligned} f_1 &= \frac{F}{A} \left(1 + \frac{x_0 x_1}{k^2} \right) \\ &= \frac{50}{12.94} \left(1 + \frac{3 \times 6}{2 \times 24.3} \right) \\ &= \frac{25}{6.47} (1 + 0.37) \\ &= +5.3 \text{ tons per sq. in. compressive.} \end{aligned}$$

From Equation (4).

Minimum intensity of stress at outer edge of flange furthest from load—

$$\begin{aligned} f_2 &= \frac{F}{A} \left(1 - \frac{x_0 x_1}{k^2} \right) \\ &= \frac{25}{6.47} (1 - 0.37) \\ &= +2.4 \text{ tons per sq. in. compressive.} \end{aligned}$$

3. In Example No. 2, if the length of \mathbf{I} -beam is, say, 8 to 10 times the least width, which corresponds to a short column, determine what load it will carry with a deviation as before of $1\frac{1}{2}$ in., for a maximum stress intensity of 6 tons per sq. in.

$$f_1 = 6 = \frac{F}{12.94} (1 + 0.37).$$

$$\therefore F = \frac{12.94 \times 6}{1.37} = 56 \text{ tons.}$$

4. A mild steel bar of rectangular section, 3 ins. by 1 in., transmits a tensile force of 5 tons. The bar is cranked, so that the line of action of the load, though parallel to the axis of the bar, coincides with the middle of one of the smaller sides. Determine the maximum and minimum intensities of stress on a normal cross section.

$$A = 3 \text{ sq. in. ; } F = -5 \text{ tons ; } x_0 = \frac{3}{2} \text{ in. ; } x_1 = \frac{3}{2} \text{ in.}$$

Maximum intensity of stress—

$$\begin{aligned} f_1 &= \frac{-F}{A} \left(1 + \frac{x_0 x_1}{k^2} \right) \\ &= \frac{-5}{3} \left(1 + \frac{3 \times 3 \times 12}{2 \times 2 \times 9} \right) \\ &= \frac{-5}{3} (1 + 3) \\ &= -6.6 \text{ tons per sq. in. } \textit{tensile}. \end{aligned}$$

$$\begin{aligned} f_2 &= \frac{-5}{3} (1 - 3) \\ &= +3.33 \text{ tons per sq in. } \textit{compressive}. \end{aligned}$$

5. A braced curved crane carries a load of 8 tons suspended from the top, at a distance of 15 feet from centre of area of base. The horizontal section at the base is a hollow rectangle 18" \times 12" outside dimensions and 1 inch thick. Determine the extreme intensities of stress on the section, if the load hangs in the plane of the central principal axis parallel to the longer side.

$$A = 216 - 160 = 56 \text{ sq. in.}$$

$$\begin{aligned} I &= \frac{12 \times 18^3}{12} - \frac{10 \times 16^3}{12} \\ &= 2418.6 \text{ inch units} \end{aligned}$$

$$\therefore k^2 = 43.2 \text{ inch units.}$$

$$x_0 = 15 \times 12 = 180 \text{ in.}; \quad x_1 = 9 \text{ in.}$$

$$F = 8 \text{ tons.}$$

Hence, maximum intensity of stress, Equation (2)—

$$\begin{aligned} f_1 &= \frac{8}{56} \left(1 + \frac{180 \times 9}{43.2} \right) \\ &= \frac{1}{7} (1 + 37.5) \\ &= 5.5 \text{ tons per sq. in. } \textit{compressive}. \end{aligned}$$

Minimum intensity of stress, Equation (4)—

$$\begin{aligned} f_2 &= \frac{1}{7} (1 - 37.5) \\ &= -5.2 \text{ tons per sq. in. } \textit{tensile}. \end{aligned}$$

6. A short strut of I-section, 12" by 5", weighing 39 lbs. per foot run, area 11.47 sq. in., sustains a load of 20 tons, which through faulty design is carried at the outer edge of centre of flange,

instead of at the centre of area. Determine in what ratio the strut is weakened.

If the force acted at centre of area, the uniform stress all over section would be $\frac{F}{A}$.

As the force acts at a distance x_0 from centre of area,
Maximum intensity of stress

$$= \frac{F}{A} \left(1 + \frac{x_0 x_1}{k^2} \right).$$

Therefore strength is reduced in the ratio of

$$\frac{1}{1 + \frac{x_0 x_1}{k^2}}.$$

In example $x_0 = 6$ in., $x_1 = 6$ in.

k^2 about axis through centre of area parallel to flange, i.e., perpendicular to plane containing centre of area and load = 22.8 inch units.

Hence strength is reduced in ratio of

$$\begin{aligned} & \frac{1}{1 + \frac{36}{22.8}} \\ &= \frac{1}{2.57}. \end{aligned}$$

7. The vertical joint at crown of an arch ring is $1\frac{1}{2}$ ft. thick. The horizontal thrust H at the crown per foot of length of arch is 6 tons acting at a distance of 3 in. above the centre of area. Determine the maximum intensity of stress on the joint.

In this example $x_0 = 3$ in. = $\frac{1}{4}$ foot, $t = \frac{3}{4}$ foot.

$$I = \frac{1 \times t^3}{12} = \frac{27}{8 \times 12}$$

$$M = Hx_0 = 6 \times \frac{1}{4} \text{ foot tons.}$$

$$\begin{aligned} \therefore f_1 &= \frac{H}{t} + \frac{Hx_0^2}{I} \\ &= \frac{6 \times 2}{3} + \frac{6 \times \frac{1}{4} \times \frac{3}{4}}{\frac{27}{96}} \end{aligned}$$

$$= 4 + 4 = 8 \text{ tons per sq. ft.}$$

21. Stability of masonry structures.

The conditions of stability at a plane joint are :

I. That the portion of the structure above the joint shall not overturn.

II. That the maximum intensity of pressure at any point in the joint shall not exceed a certain limit known to be safe.

III. That the portion of the structure above the joint shall not slide along the surface of the joint.

As the two first conditions are dependent on the position of the centre of pressure, those conditions may be stated as :—

I. The centre of pressure must fall within certain limiting positions on the surface of the joint.

II. The angle between the direction of the resultant pressure and the normal to the joint must be less than the angle of friction.

It is well to note again with reference to Condition I. that, as no *tensile* stress is permissible at any point in the surface of a masonry joint, the limiting distance of the centre of pressure from the centre of area is :—

For a rectangular joint, $\frac{1}{8}$ the thickness of the joint.

Solid circular joint, $\frac{\text{Diameter}}{8}$.

Hollow circular joint of outside diameter D and inside diameter D_1 , $\frac{D^2 + D_1^2}{8D}$.

22. Consideration of the conditions of stability. Moment of stability—External moment.

CONDITION I.—Let Fig. 34 represent in section a portion of a pier or buttress, AB being the trace of one of the bed joints.

Let W = the weight of the structure above AB , its line of action intersecting AB in D .

„ P = resultant of the external forces acting on the part whose weight is W .

„ O be centre of area of AB , and C the centre of pressure.

„ x and y be the horizontal and vertical co-ordinates of E , the point of application of P , with reference to C .

„ θ and ϕ be the inclinations to the horizontal of AB and the direction of P respectively.

The horizontal and vertical components of P are :

$$P \cos \phi \text{ and } P \sin \phi.$$

Consider the moments of P and W round the *limiting position of the centre of pressure* which is nearest to the line of action of P .

This moment of W is usually called the '*moment of stability*,' and that of P the '*external moment*.'

For stability the moment of stability must be equal to or greater than the external moment.

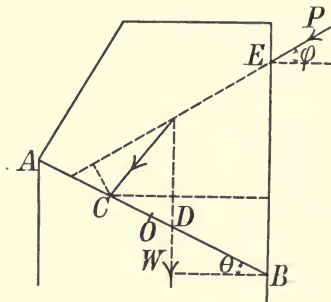

Fig. 34.

Taking moments about C :

The moment of P (which is equal to the algebraic sum of its component moments)

$$= P(y \cos \phi - x \sin \phi).$$

Moment of W

$$= W \cdot DC \cos \theta,$$

and stability requires that

$$W \cdot DC \cos \theta > P (y \cos \phi - x \sin \phi).$$

23. Line of resistance.

Let aa and bb be two joints of a masonry structure, at a distance ab apart.

Let c_1 be the centre of pressure of the joint aa , and let P_1 denote the amount and direction of the resultant force on that joint. By compounding P_1 with the weight of the block ab , the resultant P_2 is obtained acting on the joint bb through the centre of pressure c_2 .

Proceeding similarly, the centre of pressure and resultant at each successive joint below can be determined, and the stability of the structure examined.

The polygon $c_1, c_2, c_3, \&c.$, formed by joining the successive centres of pressure by straight lines is called the '*line of resistance*.'

CONDITION II.

24. The maximum intensity of pressure at any point of the joint shall not exceed the safe working strength of the material.

When the position of the centre of pressure is determined the maximum intensity of pressure can be computed by Equations (1) or (17).

25. Limiting intensities of pressure on earth foundations.

Rock, 8 to 12 tons per square foot.

Gravel and clay, 2 tons per square foot.

Loamy soil, 1 ton per square foot.

Good lime concrete, 3 to 4 tons per square foot.

CONDITION III.

26. The angle between the direction of the resultant pressure and the normal to the joint must be less than the angle of friction.

To satisfy this condition it is necessary that the tangential component of the resultant pressure shall not exceed the resistance of friction at the joint, which is the normal component of resultant multiplied by the coefficient of friction (or tangent of the angle of repose).

If ϕ is the angle of repose, then $\mu = \tan \phi$ is the coefficient of friction.

Let N and T be the normal and tangential components of the resultant thrust R ,

then T must not be greater than μN ;

that is, $\frac{T}{N}$ must not be greater than μ

or $\tan \theta$ „ „ „ „ μ ,

if θ is the angle between the direction of resultant thrust and the normal to joint. A factor of safety for frictional stability of $1\frac{1}{4}$ is usual, that is—

$\tan \theta$ must not exceed $\frac{4}{5} \tan \phi$,

or $\frac{4}{5}$ of ϕ is the limiting value of the angle of friction.

The following values may be taken for ϕ , the angle of repose ; and $\mu = \tan \phi$ (Rankine) :—

Surfaces	ϕ	$\mu = \tan \phi$
Dry masonry and brickwork .	31° to 35°	0·6 to 0·7
Masonry and brick with wet mortar	$25\frac{1}{2}^\circ$	0·47
Masonry with damp mortar . .	$36\frac{1}{2}^\circ$	0·74
Masonry on dry clay	27°	0·51
Masonry on moist clay	$18\frac{1}{4}^\circ$	0·33

27. Masonry dams.

It is most important to ensure that there is no tension on any horizontal section—that is, the resultant pressure must fall within the middle third.

The maximum intensity of compressive stress on any plane should not exceed 8 to 12 tons per square foot.

Maximum intensity of compressive stress. See Fig. 36, Example 6.

In Art. 20, Equation (17), we found an expression for the maximum intensity of compressive stress—

$$f_1 = \frac{2F}{t} \left(2 - \frac{3d}{t} \right) \dots\dots\dots(1),$$

which is the *vertical* intensity of stress due to a vertical force F acting on a horizontal joint of thickness t .

In the case of a dam, the resultant is inclined at an angle (θ) to the normal—that is, to the vertical if we are considering a horizontal joint.

Now, if we assume that the reacting stresses are parallel to the resultant, then the maximum intensity of compressive stress on horizontal plane,

$$= \frac{2R}{t} \left(2 - \frac{3d}{t} \right) \dots\dots\dots(2).$$

But, in order to obtain the real maximum intensity of compressive stress, we should consider a plane at right angles to the resultant, and this maximum value is from (2)—

$$\frac{2R}{t \cos \theta} \left(2 - \frac{3d}{t} \right) \dots\dots\dots(3).$$

If W is the weight of dam, then

$$R = \frac{W}{\cos \theta}.$$

Hence, maximum intensity of compressive stress on a plane perpendicular to R is

$$\frac{2W}{t \cos^2 \theta} \left(2 - \frac{3d}{t} \right) \dots\dots\dots(4).$$

If R acts at the middle third, *i.e.*, $d = \frac{t}{3}$, Equation (4) becomes

$$\frac{2W}{t \cos^2 \theta}.$$

Shear.—In a paper read before the Institution of Civil Engineers on the stresses in masonry dams, by Sir John Ottley and Dr. A. W. Brightmore, it was shown that the intensity of shear stress on the base was practically constant owing to the fixing of the dam at that level, but that on a horizontal section above the base the intensity of shear increases from zero at the inner face to a maximum at the outer face, so that the shear stresses

to be provided for are not necessarily those at the base, but at planes above the base near the outer profile.

Approximate section for high dams.

Molesworth's formula for high dams :—

If x = depth in feet below the top surface of a horizontal plane.

y = horizontal distance in feet from a vertical line through top inner edge of water face to outer edge of the down stream face.

z = horizontal distance in feet from the same vertical line to the edge of the inner or water face.

p = safe pressure in tons per square foot on masonry.

Then
$$y = \sqrt{\frac{0.05x^3}{p + 0.03x}}$$

and
$$z = \left(\frac{0.09x}{p}\right)^4.$$

From these equations the section of dam can be drawn, and the line of resistance drawn for reservoir empty and full.

These lines should fall within the middle third of all horizontal planes. Calculate the maximum intensity of compressive stress and if necessary modify the form of section.

The top width may be about 10 feet.

EXAMPLES.

1. *A masonry pillar, 4 feet diameter, is built of masonry weighing 140 lbs. per cubic foot. It is subjected to a wind pressure whose normal intensity is 50 lbs. per square foot. Determine the greatest safe height of the pillar.*

Assume that, owing to the convexity of the pillar, the effective wind pressure per square foot is *half* the normal intensity on a plane section through the axis of pillar.

Let h = height of pillar.

Effective wind pressure per square foot

$$= \frac{50}{2} = 25.$$

Weight of pillar

$$= W = \frac{22}{7} \times \frac{4^2}{4} \times 140h = 1760h \text{ lbs.}$$

Total effective wind pressure

$$= 25 \times h \times 4 \\ = 100h.$$

Taking moments about the *limiting* position of the centre of pressure, *i.e.*, $x_0 = \frac{d}{8}$,

$$100h \times \frac{h}{2} = W \frac{d}{8} = 1760h \times \frac{1}{2} = 880h.$$

$$\therefore h = 17.6 \text{ feet.}$$

2. A rectangular pier of masonry, 8 feet by 4 feet in section, and weighing 140 lbs. per cubic foot, is 10 feet high. It is subjected to a horizontal thrust of 2 tons applied at the top of the pier, normal to the short side. Investigate the stability of the joint at the top of the footings and calculate the greatest and least intensities of pressure.

Weight of pier is

$$W = \frac{8 \times 4 \times 10 \times 140}{2240} = 20 \text{ tons.}$$

Pressure $P = 2$ tons.

Let x_0 be the distance from centre of area to centre of pressure at the joint under consideration.

Then $Wx_0 = P \times 10$.

$$x_0 = \frac{20}{20} = 1 \text{ ft.}$$

The limiting value of x_0 is $\frac{1}{6} \cdot 8 = 1.33$ ft.

Therefore the condition that there shall be no tensile stress is satisfied. The normal component of the resultant pressure

$$= W = 20 \text{ tons.}$$

Hence maximum intensity of pressure

$$\begin{aligned} &= \frac{W}{A} + \frac{Wx_0x_1}{I} \\ &= \frac{20}{32} + \frac{20 \times 1 \times 4}{4 \times 8^3} \\ &\qquad\qquad\qquad 12 \\ &= \frac{20}{32} + \frac{15}{32} \\ &= 1.1 \text{ ton per sq. ft.} \end{aligned}$$

Minimum intensity of stress

$$\begin{aligned} &= \frac{20}{32} - \frac{15}{32} \\ &= 0.16 \text{ ton per sq. ft.} \end{aligned}$$

Frictional stability.

$$\begin{aligned}\tan \theta &= \frac{P}{W} = \frac{2}{20} = \frac{1}{10} \\ &= .1.\end{aligned}$$

By reference to table for values of $\tan \phi$ it will be seen that the condition of frictional stability is amply fulfilled.

3. *Stability of a detached buttress shown in Fig. 35.*

The thickness of buttress perpendicular to the paper is 4 feet. The loads applied to the buttress in the middle of the above thickness are:—

$P_1 = 3$ tons, acting vertically 1 foot 6 inches from the right hand top edge.

$P_2 = 12$ tons acting at a point 11 feet from the top inclined at 45° .

Weight of masonry 130 lbs. per cubic foot.

Joints AA_1 and BB_1 .

The weight of masonry above $AA_1 = 17.9$ tons.

The weight of masonry between AA_1 and $BB_1 = 21$ tons.

Centre of area of block above AA_1 is j , and centre of area of block between AA_1 and BB_1 is n .

To find m , the centre of pressure of the joint AA_1 .

In order to get the construction for resultants within limits of figure the horizontal and vertical components are taken.

The forces acting above AA_1 are the weight 17.9 tons (acting vertically through j), P_1 and P_2 .

First compound vertical weight 17.9 tons with the vertical force P_1 , by setting up $ab = 17.9$ tons on line of action P_1 , and setting down $cd = 3$ tons on vertical through j ; then the vertical through f is the line of action of resultant of weight 17.9 tons and P_1 . Produce this vertical to meet P_2 in g . From g draw gi and ih , the horizontal and vertical components of $gh = 12$ tons. From g set up vertically the length

$$gk = 17.9 \text{ tons} + 3 \text{ tons} + ih.$$

From k draw kl horizontal = gi .

Then lg is the resultant of all the forces acting above AA_1 , which when produced cuts AA_1 in m , the centre of pressure required. Its component normal to AA_1 is gk .

The point m lies within the middle third, and $\frac{kl}{kg}$ is evidently less than the limiting value $\frac{4}{5} \times 0.5$.

Centre of pressure r of joint BB_1 is found by combining the resultant lg of the forces acting on AA_1 with 21 tons, the weight of the block AB_1 acting vertically through n its centre of area.

Produce lg to intersect the vertical through n at o . From o set up $op = gk + 21$ tons; and from p draw pq horizontal $= gi$. Then go is the resultant of all the forces acting above BB_1 . Produce go to cut the joint BB_1 in r , which is the centre of pressure.

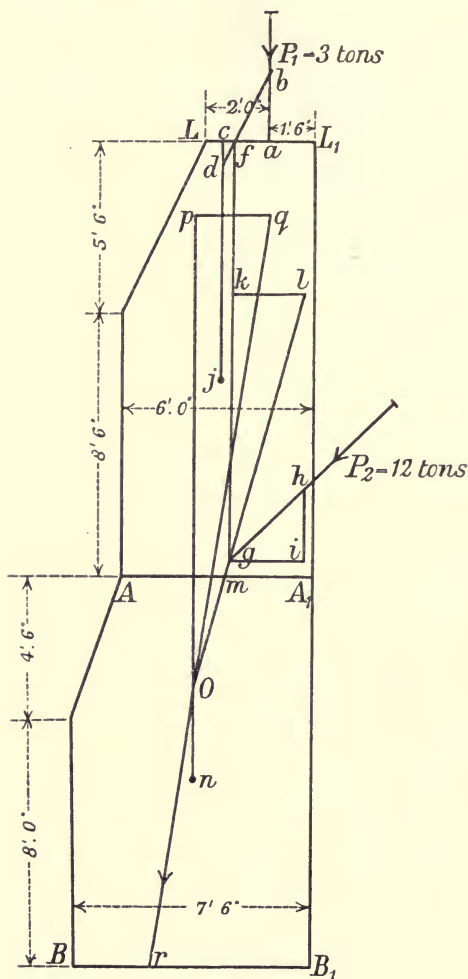

Fig. 35.

The normal component of resultant is go
 $= 3 + 12 \sin 45^\circ + 17.9 + 21$
 $= 50.4$ tons.

The centre of pressure r is at the middle third near the edge B . Hence, maximum intensity of compressive stress at B

$$\begin{aligned}
 &= \frac{2 \times 50.4}{7.5 \times 4} \\
 &= 3.36 \text{ tons per sq. ft.}
 \end{aligned}$$

4. *A masonry wall with vertical face is subjected to water pressure. The wall is trapezoidal in vertical section; the thickness at the top being t_2 , and the thickness at the bottom t_1 . If the water is level with the top of wall, determine the height h of the wall so that the resultant pressure will act at the outer middle third of the base.*

Let w = weight of cubic foot of water.

„ w_1 = weight of cubic foot of masonry.

„ ρ = specific gravity of the masonry = $\frac{w_1}{w}$.

Consider a strip of wall 1 foot long.

The section of wall can be divided up into a rectangle of area t_2h , and a triangle of area $\frac{t_1 - t_2}{2}h$.

The resultant water pressure is $\frac{wh^2}{2}$ acting at a height of $\frac{h}{3}$ above the base.

Taking moments about the outer middle third of t_1 , we get

$$\begin{aligned}
 \frac{wh^3}{6} &= w_1 \left\{ t_2h \left(\frac{2}{3}t_1 - \frac{t_2}{2} \right) + \frac{t_1 - t_2}{2}h \left[\frac{2}{3}t_1 - t_2 - \frac{1}{3}(t_1 - t_2) \right] \right\} \\
 &= \frac{w_1h}{6} (t_1^2 + t_1t_2 - t_2^2) = \frac{w\rho h}{6} (t_1^2 + t_1t_2 - t_2^2).
 \end{aligned}$$

Therefore $h^2 = \rho (t_1^2 + t_1t_2 - t_2^2)$ (1);
 or, if h and t_2 are given, then t_1 can be found from this equation.

To find the distance of the line of action of weight of wall from the vertical face.

Let x = distance required. Taking moments about inner edge of base.

Section	Area	Arm	Moment
Rectangular part . . .	t_2h	$\frac{t_2}{2}$	$h \frac{t_2^2}{2}$
Triangular part . . .	$\frac{t_1 - t_2}{2}h$	$t_2 + \frac{t_1 - t_2}{3}$	$\frac{h}{6}(t_1^2 + t_1t_2 - 2t_2^2)$
Whole area	$\frac{t_1 + t_2}{2}h$	x	$\frac{h}{6}(t_1^2 + t_1t_2 + t_2^2)$

$$\therefore x = \frac{t_1^2 + t_1 t_2 + t_2^2}{3(t_1 + t_2)}.$$

Triangular dam.

If $t_2 = 0$ in equation (1) of this example, the vertical section of the wall becomes a triangle of base t_1 and height h , and we get

$$h^2 = \rho t_1^2.$$

Therefore

$$h = t_1 \sqrt{\rho},$$

or

$$t_1 = \frac{h}{\sqrt{\rho}}.$$

5. *A masonry dam trapezoidal in section with a vertical face, height 20 feet, thickness at top 4 feet, thickness at base 12 feet, has to retain water level with the top. Determine the maximum intensity of pressure on the base. Weight of masonry 140 lbs. per cubic foot.*

Consider 1 foot length of wall.

To find distance of line of action of weight from vertical face take moments about inner edge of base.

Divide the section into a rectangle and triangle.

Area	Arm	Moment
80	2	160
80	20 3	533·3
160	x	693·3

$$\therefore x = \frac{693}{160} = 4\cdot3 \text{ feet.}$$

$$W = \text{weight of wall} = \frac{8 \times 20 \times 140}{2240} \\ = 10 \text{ tons.}$$

$$P = \text{water pressure acting at } \frac{h}{3} \text{ above base} \\ = \frac{wh^2}{2} = \frac{62\cdot5 \times 400}{2 \times 2240} \\ = 5\cdot6 \text{ tons.}$$

Let z = distance from line of action of W to centre of pressure.

Then

$$\frac{z}{\frac{h}{3}} = \frac{P}{W},$$

or

$$\frac{z}{20} = \frac{5.6}{10} = .56.$$

$$\therefore z = 3.7 \text{ feet.}$$

Therefore total distance from inner edge of base to centre of pressure

$$= 4.3 + 3.7 = 8 \text{ feet.}$$

Hence x_0 = eccentricity of load = $8 - 6 = 2$ feet = $\frac{\text{base}}{6}$.

The point of application of resultant is therefore at the middle third nearest the outer face.

Hence maximum intensity of stress (Art. 19)

$$= 2 \frac{W}{A} = \frac{2 \times 10}{12} = 1.66 \text{ ton per sq. ft.}$$

Shear.

The intensity of shear on base, which is practically uniform,

$$= \frac{5.6}{12} = 0.47 \text{ ton per sq. ft.}$$

Frictional stability.

If θ is the angle between resultant pressure and the normal to base

$$\tan \theta = \frac{3.7}{20} = 0.56,$$

which is less than $\frac{4}{3} \tan \phi$, and therefore safe.

6. *A masonry dam has a horizontal base 115 feet wide. It retains a depth of water of 150 feet. Assume that the weight of 1 foot in length of the dam is 500 tons, and that the resultant thrust acts at 45 feet from outer edge of base. Determine the maximum intensities of stress on the base. Fig. 36. Take 1 cubic foot of water to weigh $\frac{1}{8}$ of a ton.*

Consider 1 foot in length of the dam.

The total water pressure is

$$\frac{wh^2}{2} = \frac{1}{36} \frac{150^2}{2} = 312.5 \text{ tons.}$$

Horizontal component of resultant thrust = 312.5 tons.

Vertical component of resultant thrust = 500 tons.

Substituting in Formulas (18) and (19)—

$$\begin{aligned} \text{Maximum intensity of stress, } f_1 &= \frac{2W}{t} \left(2 - \frac{3d}{t} \right) \\ &= \frac{2 \times 500}{115} \left(2 - \frac{3 \times 45}{115} \right) \\ &= 7.18 \text{ tons per sq. ft.} \end{aligned}$$

$$\begin{aligned} \text{Minimum intensity of stress, } f_2 &= \frac{2W}{t} \left(\frac{3d}{t} - 1 \right) \\ &= \frac{2 \times 500}{115} \left(\frac{3 \times 45}{115} - 1 \right) \\ &= 1.5 \text{ ton per sq. ft.} \end{aligned}$$

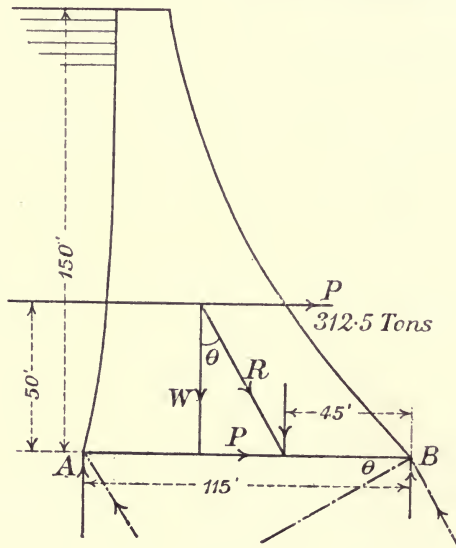

Fig. 36.

These are the *vertical* intensities at the outer edges of the horizontal base *B* and *A* respectively.

The *mean* intensity is $\frac{8.68}{2} = 4.34$ tons per sq. ft.

NOTE.—The *maximum intensity of pressure* is on a plane at right angles to the resultant *R*.

Resultant pressure = $\sqrt{500^2 + 312.5^2} = 589$ tons.

Maximum intensity of stress on a section at right angles to the resultant

$$= \frac{f_1}{\cos \theta}$$

where
$$\cos \theta = \frac{W}{\sqrt{W^2 + P^2}} = \frac{500}{589}$$

Hence,

The maximum stress intensity at $B = 7.18 \times \frac{589}{500}$
 $= 8.48$ tons per sq. ft.

The maximum stress intensity at $A = 1.5 \times \frac{589}{500}$
 $= 1.75$ ton per sq. ft.

Shear.—The intensity of shear on base is practically uniform and equals

$$\frac{312.5}{115} = 2.7 \text{ tons per sq. ft.}$$

28. To find the height to which a masonry dam of triangular section may be built consistent with the conditions of stability: (a) That the resultant pressure shall cut the base at $\frac{2}{3}$ of its thickness from the inner face; (b) That the limiting intensity of pressure shall not be exceeded.

Assume the water level with the top of the dam (Fig. 37).

Let h = height of dam.

„ t = thickness at base.

„ W = weight of masonry.

„ ρ = specific gravity of masonry.

„ R = resultant pressure on base.

„ f = limiting intensity of pressure.

„ w_1 = weight of one cubic foot of masonry
 $= \rho w$.

„ w = weight of one cubic foot of water.

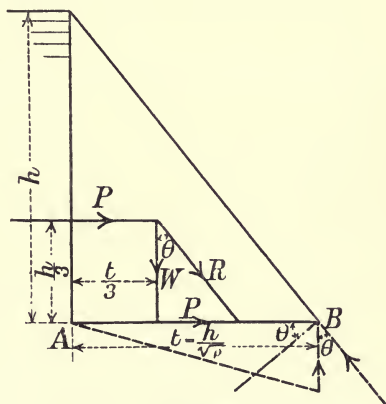

Fig. 37.

In the latter part of Example 4, page 54, it was shown that in the case of a triangular section in which condition (a) is fulfilled

$$t = \frac{h}{\sqrt{\rho}}$$

Assume that the stresses on base are parallel to the resultant, the maximum intensity of pressure will be on a plane at right angles to R , and if this intensity is f tons per square foot, then the intensity on the horizontal base $AB = f \cos \theta$.

Therefore average intensity of pressure on $AB = \frac{f \cos \theta}{2}$.

But average intensity of pressure on AB is

$$\begin{aligned} \frac{R}{AB} &= \frac{W}{h} \\ &= \frac{W \sqrt{\rho}}{h \cos \theta} \end{aligned}$$

$$\therefore \frac{f \cos \theta}{2} = \frac{W \sqrt{\rho}}{h \cos \theta}$$

or
$$\frac{f \cos^2 \theta}{2} = \frac{W \sqrt{\rho}}{h} \dots \dots \dots (1).$$

But

$$W = \frac{w_1 h^2}{2} \frac{1}{\sqrt{\rho}} = \frac{w h^2}{2} \sqrt{\rho},$$

and

$$\cos \theta = \frac{\frac{h}{3}}{\sqrt{\left(\frac{h}{3}\right)^2 + \left(\frac{h}{3 \sqrt{\rho}}\right)^2}} = \sqrt{\frac{\rho}{1 + \rho}}$$

Substituting for W and $\cos \theta$ in Equation (1)—

$$\frac{f \rho}{1 + \rho} = w h \rho.$$

Hence,

$$f = w h (1 + \rho),$$

or

$$h = \frac{f}{w(1 + \rho)}.$$

EXAMPLE.

A masonry dam, triangular in section, is 25 feet high (Fig. 38). Determine the thickness of base and draw the line of resistance for the two cases—(a) reservoir empty; (b) reservoir full. Find the maximum pressure on base. Specific gravity of masonry = $2\frac{1}{4}$.

Let t = thickness at any section of wall.

„ h = corresponding height.

$$\text{Thickness at base} = \frac{h}{\sqrt{\rho}} = \frac{25}{\sqrt{2\frac{1}{4}}} = \frac{50}{3} = 16 \text{ feet } 7\frac{1}{2} \text{ inches.}$$

Make the thickness at top 3 feet. If we draw a vertical through the outer edge of this 3 feet it cuts the sloping triangular line at a depth of 4 feet 6 inches below top.

Divide the remainder, the height, 20 feet 6 inches into 4 equal spaces, each 5 feet 1½ inch high; and we thus get 5 sections, including the base.

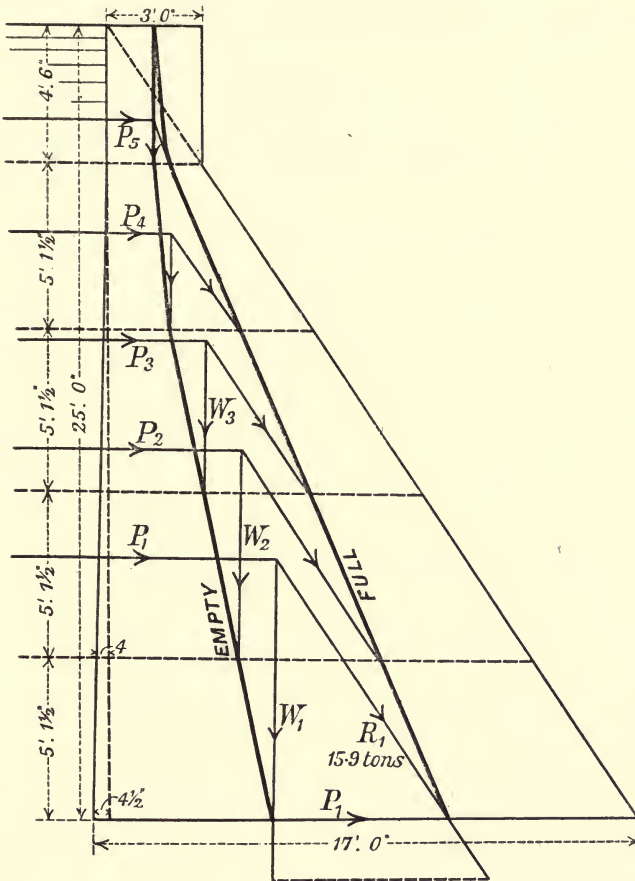

Fig. 38.

To find the different values of water pressures P , and the weights of masonry in order to get the resultants—

$$P = \frac{wh^2}{2} \text{ where } w = \text{weight of 1 cubic foot of water} = \frac{1}{36} \text{ ton.}$$

$$W = \frac{w_1 h^2}{2} \cdot \frac{1}{\sqrt{\rho}} = \frac{wh^2}{2} \sqrt{\rho}.$$

The ordinate at base from vertical line of triangle to inner face is $4\frac{1}{2}$ inches, making the total thickness of base = $16'7\frac{1}{2}" + 4\frac{1}{2}" = 17$ feet.

For the reservoir empty, the centre of pressure on any joint is got by drawing the vertical line through the centre of area of the masonry section above joint. For the reservoir full, the centre of pressure on any joint is got by finding the intersection of the resultant (of water pressure and weight of masonry above the joint) with the joint.

The water pressures act horizontally at a height of $\frac{h}{3}$ above the joint. The joints considered and the blocks of masonry into which they divide the section are numbered 1 to 5 from the base upwards.

Table of Dimensions, Weights, and Pressures.

Depth below surface	Thickness of base	Weight of masonry	Extra thickness from vertical	Water pressures
Ft. in.	Ft. in.	Tons	In.	Tons
4 6	3 0	$W_5 = 0.85$	$x_5 = 0$	$P_5 = 0.3$
9 $7\frac{1}{2}$	6 5	$W_4 = 2.42$	$x_4 = \frac{1}{2}$	$P_4 = 1.3$
14 9	10 0	$W_3 = 4.92$	$x_3 = 2$	$P_3 = 3.0$
19 $10\frac{1}{2}$	13 $5\frac{1}{2}$	$W_2 = 8.62$	$x_2 = 3\frac{1}{2}$	$P_2 = 5.5$
25 0	17 0	$W_1 = 13.42$	$x_1 = 4\frac{1}{2}$	$P_1 = 8.7$

Let f = maximum intensity of pressure on masonry at the outer toe—

$$f = hw(1 + \rho) = 25 \times \frac{1}{3} \times \frac{1}{8} (1 + 2\frac{1}{4}) = 2.27 \text{ tons per sq. ft.}$$

For the reservoir empty the maximum intensity of pressure is at inner toe—

$$= \frac{2W}{t} = \frac{2 \times 13.42}{17} = 1.57 \text{ ton per sq. ft.}$$

The average value of shear over base = $\frac{8.7}{17} = 0.52$ ton per sq. ft.

CHAPTER IV.

TYPES OF GIRDERS—WORKING STRESSES AND CROSS SECTIONAL AREAS—STRESSES IN GIRDERS WITH PARALLEL CHORDS BY METHOD OF COEFFICIENTS.

29. Chords and web. Forms of girders.

A girder consists of—

(a) An upper member arranged in a straight or polygonal line, and called the '*top chord*' or '*top flange*.'

(b) A lower member similarly formed and called the '*lower chord*' or '*lower flange*.'

(c) A series of members, either all inclined, or some vertical and others inclined, connecting the two chords, and forming with them a series of triangles. These are called the '*web*.'

A *girder of uniform depth* has both chords straight and parallel.

A *girder of variable depth* has usually the top chord curved or polygonal, and the bottom chord straight, the greatest depth being at the centre.

Girders of uniform depth belong to two principal classes:—

(a) Those in which the web-bars make alternately equal and opposite angles with the vertical, forming with the chords a system of *isosceles triangles*. This type is called a '*Warren girder*.'

(b) Those in which the web-bars are alternately vertical and inclined, forming with the chords a system of right-angled triangles. This type is called a '*Pratt Girder*' or '*N girder*.'

The portion of either chord comprised between two adjacent joints is called a '*bay*' or '*panel length*'; each corresponding division of the girder is called a '*panel*.'

30. Loads on girders.

(a) The *dead load* due to the weight of the main girders, cross girders, flooring, and lateral bracing; it is usually taken as a uniform load, and is considered either as equally distributed at

the joints of one chord, or as distributed at the joints of the two chords, each joint of the same chord carrying an equal load.

(b) The *live load* which travels over the bridge, such as a crowd of people or a train of vehicles.

There are two methods of considering the live load in the design of girder.

(a) *The equivalent uniform load.* To find the uniform load which is *equivalent* to the actual load draw the *maximum* bending moment diagram for the loads and then find the parabola which circumscribes or passes everywhere just outside this diagram. This parabola is the bending moment diagram of the equivalent uniform load.

(b) A typical live load is taken, consisting of a series of locomotive and wagon axle loads, and the maximum bending moments are found for different positions of the axle loads.

Both these methods are applied in the examples which follow.

31. Counterbracing.

For certain positions of the live load the ties or tension members of the web will be subject to compression. The *maximum* stress in a tension member of the web is the sum of the maximum tensile stresses due to dead and live loads. The *minimum* stress in the same member is the difference between the dead load tensile stress and the live load compressive stress, and if the live load compressive stress is greater than the dead load tensile stress, then, of course, the minimum stress is compressive.

The tie-bars in which this reversal of stress takes place must be *counterbraced* by inserting a second diagonal tie in the panel, crossing the first in the opposite direction. These panels in which two diagonals occur are said to be *counterbraced*, and the additional diagonal is called a *counterbrace*. Both these diagonals are tension members, one only being in action at a time; and the minimum stresses for these diagonals in a counterbraced panel are zero.

Counterbracing is also often done by bracing and stiffening the tie with extra material.

32. Working stress. Area of cross section of members.

The working stress is the maximum stress which a member will have to bear in actual practice when fully loaded, and should be a fraction only of the breaking strength. The factor by which the breaking strength is divided to get the working stress is called the '*factor of safety*.'

This method of determining the working stress is an empirical one. Wöhlers's experiments prove that the safety of a structure depends not on the maximum intensity of stress to which it is exposed, but on the *range of stress* and the number of repetitions of the range of stress. Thus, if a structure is subjected to a steady load, the working stress may be greater than when the structure is subject to a varying stress of one kind (tensile or compressive); and when the structure is subjected to alternate stress of opposite kinds (tensile *and* compressive) the working stress must be still less.

LAUNHARDT'S AND WEYRAUCH'S METHOD.

Let t be the *statical breaking strength*.

Then, if the piece be subjected to stresses which vary from a maximum S to a minimum S ,

Launhardt-Weyrauch formula gives—

$$\text{The breaking stress} = \frac{2}{3}t \left(1 + \frac{1}{2} \frac{\text{min. } S}{\text{max. } S} \right).$$

With a factor of safety of 3, we get

$$\text{Working stress} = \frac{2}{9}t \left(1 + \frac{1}{2} \frac{\text{min. } S}{\text{max. } S} \right) \dots\dots\dots(a).$$

The sectional area of the bar or member

$$= \frac{\text{the maximum load}}{\text{working stress}}.$$

DYNAMIC METHOD (Claxton Fidler).

If a bar or member of a structure is strained by an initial stress P , and an additional stress F be *suddenly* applied, which produces a deformation l , we get a stress strain diagram as in Fig. 39, in which the energy $P + F$ is represented by the area $ABEH$, and the work done on the bar is represented by the area $ABGC$. As these two areas must be equal, we get

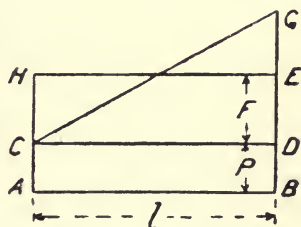

due to F

Fig. 39.

$$GE = ED = F,$$

and the *dynamically increased stress*

$$\begin{aligned} &= BG \\ &= BE + EG = \overline{P + F} + F \\ &= \text{statical stress} + \text{variation in stress}; \end{aligned}$$

or, denoting the initial stress $DB = P$ by min. S , and $BE = P + F$ by max. S ,

then GE , the variation in stress = max. S . - min. S .
that is :

$$\begin{aligned} \text{The maximum dynamically increased stress} \\ = \text{max. } S + (\text{max. } S - \text{min. } S). \end{aligned}$$

If, as before, t = statical breaking stress, and 3 = factor of safety,

$$\begin{aligned} & \text{Area of cross section of member} \\ &= \frac{\text{max. } S + (\text{max. } S - \text{min. } S)}{\frac{t}{3}} \\ &= \frac{3}{t} \{ \text{max. } S + (\text{max. } S - \text{min. } S) \} \dots\dots\dots (b). \end{aligned}$$

NOTE.—The maximum stress is the maximum static stress due to both dead and live loads.

In applying this formula, the variation of stress is more gradual in the *flange or chord* members of triangulated girders than in the other members, and for these it is usual to take *half the variation* only, thus :

$$\text{Flange area} = \frac{3}{t} \{ \text{max. } S + \frac{1}{2} (\text{max. } S - \text{min. } S) \} \dots\dots\dots (c).$$

ANOTHER RULE for determining the *maximum* stress in any member is to add to the dead load stress the maximum live load stress multiplied by a coefficient. This coefficient is 2 in all cases, except for the upper and lower chords of triangulated girders for which a coefficient of 1.5 may be used.

Thus, *cross sectional area of member*

$$= \frac{3}{t} (\text{dead load stress} + 2\text{-live load stress}) \dots\dots\dots (d).$$

EXAMPLES.

1. *The stresses in a mild steel member of a structure are as follows :—*

Stress due to dead load = 50 tons tension.

Stress due to live load coming from one side = 30 tons tension.

Stress due to live load coming from the other side = 10 tons compression.

Determine the working stress by Launhardt-Weyrauch method and the necessary cross sectional area of the member.

From (a)

$$\text{Working stress} = \frac{2}{9} t \left(1 + \frac{1}{2} \frac{\text{min. } S}{\text{max. } S} \right).$$

Take $t = 27$ tons per square inch ;

$$\text{Max. } S = 50 + 30 = 80.$$

$$\text{Min. } S = 50 - 10 = 40.$$

$$\begin{aligned} \text{Working stress} &= \frac{2 \times 27}{9} \left(1 + \frac{1}{2} \frac{40}{80} \right) \\ &= \frac{6 \times 5}{4} = 7\frac{1}{2} \text{ tons per square inch.} \end{aligned}$$

Cross sectional area

$$= \frac{80}{7\frac{1}{2}} = 10\frac{2}{3} \text{ square inches.}$$

2. *The stresses in one of the web-braces of a mild steel girder are :*

Stress due to dead load = 60 tons tension.

Stress due to live load—

Longer segment covered = 100 tons tension.

Shorter segment covered = 15 tons compression

Determine the cross sectional area of the member by dynamic method, equation (b), and by rule equation (d).

Max. $S = 160$ tons tension. Min. $S = 45$ tons tension.

Max. $S - \text{min. } S = 115$ tons.

$t = 27$ tons per square inch.

Area of cross section from equation (b).

$$= \frac{275}{9} = 30.6 \text{ square inches}$$

From equation (d)

Area of cross section

$$= \frac{60 + 2 \times 100}{9} = \frac{260}{9}$$

= 29 square inches.

3. *The stresses in a tension web-brace near the centre of a mild steel girder are as follows :—*

Stress due to dead load = 7 tons tension.

Stress due to live load—

Longer segment covered = 59 tons tension.

Shorter segment covered = 27 tons compression.

Should the brace have a counterbrace, and, if so, find the sectional area of the brace by dynamic method.

Max. $S = 66$ tons tension.

Min. $S = 20$ tons compression.

The panel must be counterbraced, since the compressive live load stress exceeds the dead load tensile stress.

If counterbraced by a second diagonal brace the min. $S = 0$. Hence, by equation (b), taking $t = 27$ tons per square inch,

$$\begin{aligned} \text{Area of cross section} &= \frac{66 + (66 - 0)}{9} \\ &= \frac{132}{9} = 14\frac{2}{3} \text{ square inches.} \end{aligned}$$

33. Stresses in girders with parallel chords.

METHOD OF COEFFICIENTS, THE LIVE LOAD BEING ASSUMED EQUALLY DISTRIBUTED AT PANEL POINTS.

The total stress in any member of a girder can be conveniently found by adding algebraically the partial stresses occurring in that member, due to the load at each panel point taken separately. The work may be arranged in tabular form as explained in the examples which follow. The method is according to notes taken from the late Professor Reilly.

Stresses in web members.

Let n = the number of equal bays or panel lengths in the girder.

„ W = load at a panel point.

„ a = the number of bays between the single load considered and the *left* support.

„ b = the number of bays between the same load and the *right* support.

„ θ = angle of inclination of bracing with horizontal.

Considering the single load W .

The shearing force on any vertical section to the left of W

$$= \frac{Wb}{n}.$$

The shearing force on any vertical section to the right of W

$$= \frac{Wa}{n}.$$

Now the shearing force F in any panel length is equal to the vertical component of the stress in the inclined brace in that panel, and the

$$\text{Stress in inclined brace} = F' \operatorname{cosec} \theta.$$

Thus, the numerical value of the partial stress in a brace to the *left* of the single load W is

$$f' = \frac{W \operatorname{cosec} \theta}{n} \cdot b \dots \dots \dots (1),$$

and in a brace to the *right* of the load W

$$f'' = \frac{W \operatorname{cosec} \theta}{n} \cdot a \dots \dots \dots (2).$$

For any given brace the stress due to each load on the same side of the brace is of the same sense ; but the stress due to a load on the other side of the brace is opposite in sense.

Thus, for the same brace f' , f'' *must have opposite signs*. The total stress in any one brace will then be the *algebraic sum*

$$\Sigma f' + \Sigma f'' \dots \dots \dots (3).$$

The first sum includes all the loads on the *right* of the brace and the second all the loads on the *left* of the brace. The girder, being usually symmetrical, the braces on the *left* of centre line will be considered, and compression will be indicated by a + sign ; tension by a - sign.

Thus f' will be + for struts, - for ties.
 f'' will be - for struts, + for ties.

Stress in any one brace due to dead load.

Let W_1 = dead load acting at each joint.

Then from Equations (1), (2), and (3) the stress

$$f_1 = + \frac{W_1}{n} \operatorname{cosec} \theta \{ \Sigma b - \Sigma a \} \dots \dots \dots (4).$$

Stress in any one brace due to live load only.

Let W_2 = live load acting at each joint.

Considering a brace in the *left hand* half of the girder the *maximum* stress in it occurs when all the joints to the *right* of the brace are each loaded by W_2 , the joints to the left of the brace being unloaded.

The value of this stress is

$$f_2 = \Sigma f' = \frac{W_2}{n} \operatorname{cosec} \theta \Sigma b \dots \dots \dots (5)$$

where the summation includes all the loaded joints on the *right* of a vertical section cutting the brace in question.

The sense of f_2 is *positive* or *negative* according as the brace is a *strut* or a *tie*.

The *minimum* stress occurs when the shorter segment only is loaded—that is, when all the joints to the *left* of the brace are loaded by W_2 ; its value is

$$f_2' = \Sigma f'' = \frac{W_2}{n} \operatorname{cosec} \theta \Sigma a \dots \dots \dots (6)$$

where the summation includes all the loads on the *left* of the brace.

The sense of f_2' is *positive* or *negative* according as the brace is a *tie* or a *strut*.

Resultant stresses due to both dead and live loads.

$$\left. \begin{aligned} \text{Maximum} &= f_1 + f_2 \\ \text{Minimum} &= f_1 + f_2' \end{aligned} \right\} \dots\dots\dots (7)$$

Signs being implied.

If the maximum and minimum are both of the same sign no counterbrace is required, if of opposite sign then a counterbrace is necessary.

34. Stress in the chord members due to dead and live loads.

The maximum stress in each member of the chords occurs when the span is fully loaded with both the dead and live loads. The amount of this stress for any one chord member or bay is the sum of the horizontal components of stress in all the inclined braces between the bay in question and the nearest support. The horizontal component of stress in an inclined brace is equal to the vertical component multiplied by $\cot \theta$.

Thus the maximum stress in any chord member is

$$\Sigma \left[\frac{W_1 + W_2}{n} \cot \theta \{ \Sigma b - \Sigma a \} \right] \dots\dots\dots (8),$$

where the sign of summation includes all the braces between the nearest support and the bay considered.

The stress in each member of the top chord is *compressive*, and in each member of the bottom chord *tensile* when the girder is simply supported at the two ends.

The application of this method is best illustrated by the examples which follow.

EXAMPLES.

1. A Warren girder of 100 feet span (Fig. 40), length of panel 10 feet, depth 10 feet, carries a uniform dead load of 0.6 ton per foot

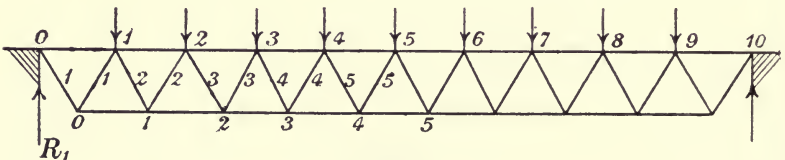

Fig. 40.

run, and a uniform live load of $1\frac{1}{2}$ ton per foot run, both supported at the joints of the top chord. Determine the maximum stress in each brace and chord member.

$$W_1 = 0.6 \times 10 = 6 \text{ tons.}$$

$$W_2 = 1\frac{1}{2} \times 10 = 15 \text{ tons.}$$

$$n = 10.$$

$$\theta = \tan^{-1} 2 = 63^\circ 26'.$$

$$\operatorname{cosec} \theta = 1.118; \cot \theta = 0.5.$$

$$\frac{W_1}{n} = \operatorname{cosec} \theta = 0.671; \frac{W_2}{n} \operatorname{cosec} \theta = 1.68;$$

$$\frac{W_1 + W_2}{n} \cot \theta = 1.05.$$

The stresses are most easily obtained by arranging the work in tabular form (see Table I., page 71).

In Fig. 40 the braces of each kind, viz. struts and ties, are numbered in order from the left to the centre of span. The first column of table contains those numbers for braces of *one* kind—*ties* are taken in the present example. Columns 2 to 10 contain the coefficients a , b , corresponding to the loaded joints 1 to 9 of the top boom. The signs prefixed are according to the sense of stress in the *ties*. The values of a are positive, since the load on the left of a tie produces positive or compressive stress on it, and those of b are negative since a load on the right produces negative or tensile stress in the same tie.

Column 11 gives $\Sigma b - \Sigma a$.

„ 12 „ Σb .

„ 13 „ Σa .

Column 14 gives f_1 (Equation 4), being the numbers in column 11 multiplied by $\frac{W_1}{n} \operatorname{cosec} \theta$.

Columns 15 and 16 are got by multiplying the numbers in columns 12 and 13 respectively by $\frac{W_2}{n} \operatorname{cosec} \theta$.

Column 17 gives the maximum stresses for *ties*, obtained from columns 14, 15, 16 by Equation (7), the value of the minimum stress only being given where it is of opposite sign to the maximum.

Column 18 gives the maximum stresses in *struts*, which are equal in value and opposite in sense to those in column 17, since the struts and ties, similarly numbered, meet at the same joint of the unloaded chord and are equally inclined in opposite directions.

Column 19 contains the horizontal components of stress in braces, being the numbers in column 11 multiplied by $\frac{W_1 + W_2}{n} \cot \theta$, Equation (8).

Columns 20, 21 give the maximum stress in each bay of the top and bottom chords, being the sum of the horizontal components of stress in all the inclined braces between the bay in question and the nearest support.

Thus *Bay 1-2 of top chord*. The braces between this bay and the left support are tie 1, strut 1, and tie 2.

$$\begin{aligned} \text{Hence stress in bay 1, 2} &= 2 \times 47.25 + 36.75 \\ &= 131.25 \text{ tons compression.} \end{aligned}$$

Bay 1-2, bottom chord.—The braces between this bay and left support are tie 1, strut 1, tie 2, and strut 2.

$$\begin{aligned} \text{Hence stress in bay 1-2} &= 2 \times 47.25 + 2 \times 36.75 \\ &= 168.00 \text{ tons tension.} \end{aligned}$$

Check by moments.

To find the stress in middle bay of top chord.

Take moments about the bottom joint 4.

$$\begin{aligned} M &= \frac{9}{2} (6 + 15) \text{ tons} \times 4\frac{1}{2} \text{ bays} - (6 + 15) \text{ tons} \left(\frac{1}{2} + 1\frac{1}{2} + 2\frac{1}{2} + 3\frac{1}{2} \right) \text{ bays} \\ &= 21 \left(\frac{81}{4} - 8 \right) = 257.25 \text{ bay tons.} \end{aligned}$$

$$\text{Stress} = \frac{M}{d} = \frac{M}{1 \text{ bay}} = 257.25 \text{ tons,}$$

which agrees with the tabular calculation.

2. *A Pratt girder, 104 feet span (Fig. 41), divided into 8 bays with depth $\frac{1}{10}$ of the span, carries a dead load of 4 tons and a live load of*

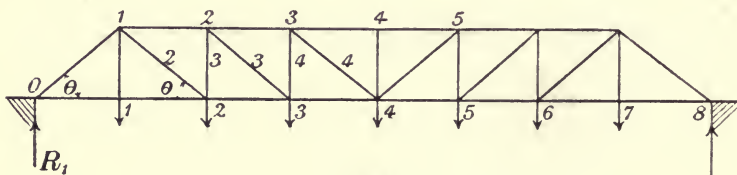

Fig. 41.

7.5 tons, both concentrated at the joints of the bottom chord. Determine the stress in each member of the bracing and chords.

From Fig. 41 it is seen that the first inclined brace is a strut, and Nos. 2, 3, 4 are ties. Consequently in the first line of Table II. the coefficients b are +, and in 2nd, 3rd, and 4th lines the coefficients a are + and b are -.

The vertical 1-1 is a tie, simply transmitting the load from joint 1 of the bottom chord to joint 1 of top chord. Verticals 3 and 4 are struts. Vertical 4-4 simply steadies the double bay 3-4-5 of top chord.

Data.— $W_1 = 4$ tons ; $W_2 = 7.5$ tons ; $n = 8$.

TABLE I.

No. of Brace	Coefficients for Ties due to Load at Joint No.									BRACES					CHORDS							
	1			2			3			Algebraic Sum of Coefficients	Sum of + Coefficients	Sum of - Coefficients	Sum of + Coefficients	TIES		STRUTS		Horizontal Components of Stresses in Braces	Maximum Stresses in Top Chord	Maximum Stresses in Bottom Chord	No. of Bay	
	1	2	3	4	5	6	7	8	9					Dead Load Stress	Live Load Stresses	Maximum Stresses	Maximum Stresses					Maximum Stresses
1	-9	-8	-7	-6	-5	-4	-3	-2	-1	-45	0	-30.2	-75.6	-	-	-105.8	+105.8	47.25	+47.25	-	94.50	0-1
2	+1	-8	-7	-6	-5	-4	-3	-2	-1	-35	+1	-23.5	-60.5	+1.7	-	-84.0	+84.0	36.75	+131.25	-	168.00	1-2
3	+1	+2	-7	-6	-5	-4	-3	-2	-1	-25	+3	-16.8	-47.0	+5.0	-	-63.8	+63.8	26.25	+194.25	-	220.50	2-3
4	+1	+2	+3	-6	-5	-4	-3	-2	-1	-15	+6	-10.1	-35.3	+10.0	-	-45.4	+45.4	15.75	+236.25	-	252.00	3-4
5	+1	+2	+3	+4	-5	-4	-3	-2	-1	-5	+10	-3.4	-25.2	+16.8	-	-28.6	+28.6	5.25	+257.25	-	262.50	4-5
Columns	1	2	3	4	5	6	7	8	9	10	11	12	13	14	15	16	17	18	19	20	21	22

Braces 4 and 5 will require counterbracing.

In order to allow for the increased stress due to the live load W_1 is taken = $2 \times 7.5 = 15$ tons.

$$\theta = \cot^{-1} \frac{\left(\frac{1}{8}\right)}{\left(\frac{1}{10}\right)} = \cot^{-1} 1.25 = 38^\circ 40'.$$

$$\text{Cosec } \theta = 1.6; \cot \theta = 1.25.$$

$$\frac{W_1}{n} \text{ cosec } \theta = \frac{4}{8} \times 1.6 = 0.8 \text{ ton}; \quad \frac{W_2}{n} \text{ cosec } \theta = \frac{15}{8} \times 1.6 = 3 \text{ tons.}$$

$$\frac{W_1 + W_2}{n} \cot \theta = \frac{19}{8} \times 1.25 = 2.97 \text{ tons.}$$

In Table No. II. the stresses are obtained and arranged in tabular form.

The verticals 3 and 4 meet the inclined braces 3 and 4 at joints 2 and 3 of the unloaded chord, hence

$$\begin{aligned} \text{Stress in vertical 3} &= \text{stress in inclined brace 3} \times \sin \theta \\ &= \frac{\text{stress in inclined brace 3}}{\text{cosec } \theta}, \end{aligned}$$

$$\text{and stress in vertical 4} = \frac{\text{stress in inclined brace 4}}{\text{cosec } \theta}.$$

Check by moments.

To find the stress in bay 3-4 of bottom chord.

Take moments about joint 3 of the top chord.

$$\begin{aligned} M &= \frac{7}{2} (4 + 15) \text{ tons} \times 3 \text{ bays} - (4 + 15) \text{ tons} (1 + 2) \text{ bays} \\ &= 19 \left(\frac{21}{2} - 3 \right) = 142.5 \text{ bay tons.} \end{aligned}$$

Then, since depth = 0.8 bay,

Stress in bay 3-4 bottom chord

$$= \frac{142.5}{.8} = -178.1 \text{ tons.}$$

3. A girder (Fig. 42), span 144 feet, divided into 6 bays by isosceles triangular bracing, depth $\frac{1}{10}$ of the span, carries a dead load of $\frac{1}{2}$ ton per foot run and a live load of 1 ton per foot run supported at the joints of bottom chord and at points midway between them. Determine the stress in each member of the bracing and chords.

In this form of girder the effective bay length is halved. The verticals are ties each transmitting the load carried at its foot to the top chord, the stress in each being $W_1 + W_2$.

TABLE II.

No. of Brace.	Coefficients for Diagonals due to Load at Joint No.							BRACING						CHORDS					
	1	2	3	4	5	6	7	Algebraic Sum of Coefficients	Sum of + Coefficients	Sum of - Coefficients	Dead Load Stress	Diagonals		Verticals	Horizontal Components of Stress in Diagonals	Stresses in Chord Members	Bottom Chord	Top Chord	
	Tons		Tons		Tons		Tons		Tons		Tons		Tons		Tons		Tons		
1	+7	+6	+5	+4	+3	+2	+1	+28	+28	0	+22.4	+84.0	0	+106.4	..	83.16	0.2	..	
2	+1	-6	-5	-4	-3	-2	-1	-20	+1	-21	-16.0	+3.0	-63.0	-79.0	..	142.56	2.3	1.2	
3	+1	+2	-5	-4	-3	-2	-1	-12	+3	-15	+9.6	+9.0	-45.0	-54.6	+34.12	178.20	3.4	2.3	
4	+1	+2	+3	-4	-3	-2	-1	-4	+6	-10	-3.2	+18.0	-30.0	+14.8	-9.25	190.08	-	3.4	

Stress on vertical 1, $1 = W_1 + W_2 = -19$ tons tension.

Diagonal 4 will require counterbracing.

As the load on girder acts at the joints of both top and bottom chords, the stress is different in each diagonal brace.

In Table III. the coefficients are taken for half-bays, and the sign prefixed to each is that of the stress in the brace to which it refers. Thus, since braces 1, 3, 5 are struts and 2, 4, 6 ties, the values of $2a$ are— and of $2b$ + in the first, third, and fifth lines of table, and in the second, fourth, and sixth lines these signs are reversed.

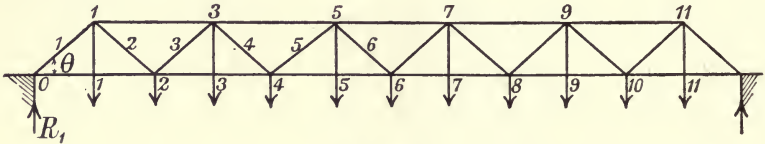

Fig. 42.

$$\text{Number of half-bays} = 2n = 12.$$

$$\text{Length of half-bay} = \frac{144}{12} = 12 \text{ feet.}$$

$$\text{Depth of girder} = \frac{144}{10} = 14.4 \text{ feet.}$$

$$\text{Inclination of diagonal braces } \theta = \tan^{-1} \frac{14.4}{12} = 50^{\circ}.12'.$$

$$\text{Cosec } \theta = 1.3; \cot \theta = 0.833.$$

$$\text{Dead load at each joint of half-bay} = 12 \times \frac{1}{2} = 6 \text{ tons} = W_1.$$

$$\text{Live load at each joint of half-bay} = 12 \times 1 = 12 \text{ tons.}$$

To allow for the increased stress due to live load

$$W_2 = 2 \times 12 = 24 \text{ tons.}$$

$$\frac{W_1}{2n} \text{ cosec } \theta = \frac{6}{12} \times 1.3 = 0.65.$$

$$\frac{W_2}{2n} \text{ cosec } \theta = \frac{24}{12} \times 1.3 = 2.6.$$

$$\frac{W_1 + W_2}{2n} \cot \theta = \frac{30}{12} \times 0.833 = 2.08.$$

Check by moments.

To find the stress in bay 5-7 of top chord.

Take moments about bottom joint 6.

$$\begin{aligned} M &= \frac{11}{2} (6 + 24) \text{ tons} \times 3 \text{ bays} \\ &\quad - (6 + 24) \text{ tons} \left(\frac{1}{2} + 1 + 1\frac{1}{2} + 2 + 2\frac{1}{2} \right) \text{ bays} \\ &= 30 \left\{ \frac{33}{2} - 7\frac{1}{2} \right\} = 270 \text{ bay tons.} \end{aligned}$$

TABLE III.

No. of Brace	BRACING											CHORDS																
	Coefficients for Inclined Braces due to Loads at Joint No.											Stress in Bays of Chords		No. of Bay		Horizontal Components of Stress												
	1	2	3	4	5	6	7	8	9	10	11	Bottom Chord	Top Chord	Bottom Chord	Top Chord													
1	+11	+10	+9	+8	+7	+6	+5	+4	+3	+2	+1	+66	+66	0	+42.9	+171.6	0	+214.5	137.3	-137.3	0-2	..				
2	+1	-10	-9	-8	-7	-6	-5	-4	-3	-2	-1	-54	+1	-55	-35.1	+2.6	-143.0	-178.1	112.3	+249.6	1-3	..		
3	-1	-2	+9	+8	+7	+6	+5	+4	+3	+2	+1	+42	+45	-3	+27.3	+117.0	-7.8	+144.3	87.4	-337.0	2-4	..		
4	+1	+2	+3	-8	-7	-6	-5	-4	-3	-2	-1	-30	+6	-36	-19.5	+15.6	-93.6	-113.1	62.4	+399.4	3-5	..
5	-1	-2	-3	-4	+7	+6	+5	+4	+3	+2	+1	+18	+28	-10	+11.7	+72.8	-26.0	84.5	-14.3	..	37.4	-436.8	4-6	..
6	+1	+2	+3	+4	+5	-6	-5	-4	-3	-2	-1	-6	+15	-21	-3.9	+39.0	-54.6	+58.5	+35.1	..	12.5	+449.3	5-7	..

Stress on each vertical bar = $W_1 + W_2 = -30$ tons tension.

Inclined braces 5 and 6 will require counterbracing.

Therefore stress = $\frac{270 \text{ bay tons}}{\text{depth in bays}} = \frac{270}{0.6} = 450 \text{ tons compression.}$

4. A girder of double triangulation (Fig. 43) of span 108 feet is divided into 9 bays by web-bracing inclined at 45° . The girder carries a dead load of 1 ton per foot run, and a live load $1\frac{1}{2}$ ton per foot run, both at the joints of bottom chord. Determine the stress in each member of the bracing and chords.

In Fig. 43 the two braces meeting at each joint of the unloaded chord are distinguished by the same number.

There are two systems of triangulation. For the bracing, the two systems must be considered as separate, whereas the chords must be taken as common to both systems. The joints of the loaded chord belong to each system alternately, and the two systems of bracing are numbered, the one with even figures, the other with odd figures. Hence in Table IV. the coefficients a and b for each brace are placed in the alternate columns, whose numbers are those of the bottom joints belonging to the same

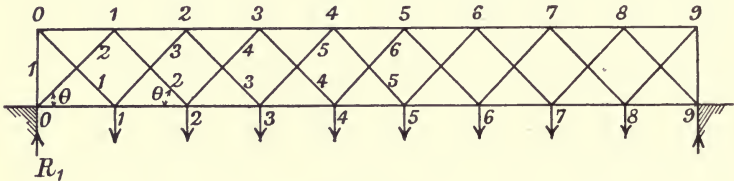

Fig. 43.

system as the brace, consequently in each horizontal row alternate columns are blank.

The coefficients are for tie braces only; and the signs prefixed are of the corresponding stresses in these members.

The stresses in the diagonal struts are equal and opposite in sense to those in the diagonal ties having the same number. The stresses in the bays of chords are obtained by successive addition of the horizontal components of stress in inclined braces. Thus, stress in bay 3-4 of bottom chord = stress in bay 2-3 + horizontal component of stress in brace 3 + horizontal component of stress in brace 5.

Stress in bay 4-5 bottom chord = stress in bay 3-4 + horizontal component of stress in brace 4 - horizontal component of stress in brace 6.

In this case the horizontal component of stress in brace 6 is subtracted, since the braces 4 and 6 are inclined in opposite directions, and the stresses in both are tensile.

TABLE IV.

No. of Brace	Coefficients for Ties due to Load at Joint No.								Algebraic Sum of Coefficients	Sum of - Coefficients	Sum of + Coefficients	TIES				Resultant Stresses	STRUSS
	1	2	3	4	5	6	7	8				Dead Load Stress	Live Load Stress		Resultant Stresses		
													Tensile	Compressive.			
1	-8	..7	-6	..5	-4	..3	-2	..1	-20	-20	..	Tons -37.8	Tons -113.2	Tons -151.0	Tons +107.2		
2	..1	..7	..6	..4	..4	..3	..2	..1	-16	-16	..	Tons -30.3	Tons -90.6	Tons -120.9	Tons +120.9		
32531	-11	-12	+1	Tons -20.8	Tons +5.7	Tons -88.7	Tons +88.7		
4	..	+25	..	-3	..	-1	-7	-9	+2	Tons -13.3	Tons +11.4	Tons -64.2	Tons +64.2		
5	+1	..	+3	..	-4	..	-2	..	-2	-6	+4	Tons -3.8	Tons +22.8	Tons -37.8	Tons +190.0		

No. of Brace	CHOORDS				No. of Member
	Stress in Chord Members				
	Top Chord		Bottom Chord		
	Horizontal Components of Stress				
	Tons	Tons	Tons	Tons	
1	106.4	+106.4	-85.2	0-1	
2	85.2	+276.8	-160.1	1-2	
3	58.6	106.4 + 2 x 85.2 = +276.8	85.2 + 106.4 + 58.5 = -282.6	2-3	
4	37.3	276.8 + 2 x 58.6 = +394.0	160.1 + 85.2 + 37.3 = -282.6	3-4	
5	10.7	394.0 + 2 x 37.3 = +468.6	282.6 + 58.6 + 10.7 = -351.9	4-5	
		468.6 + 2 x 10.7 = +490.0	351.9 + 37.3 - 10.7 = -378.5		

NOTE.—Tie No. 5 will require counterbracing.

In the example—

$$n = 9, \text{ length of bay} = \frac{108}{9} = 12 \text{ feet.}$$

The dead and live loads are :

$$W_1 = 12 \times 1 = 12 \text{ tons.}$$

$$W_2 = 12 \times 1\frac{1}{2} = 18 \text{ tons.}$$

To allow for increased stress due to live load

$$W_2 \text{ taken} = 2 \times 18 = 36 \text{ tons.}$$

$$\theta = 45^\circ; \text{ cosec } \theta = 1.414; \text{ cot } \theta = 1.$$

$$\frac{W_1}{n} \text{ cosec } \theta = \frac{12}{9} \times 1.414 = 1.89 \text{ ton.}$$

$$\frac{W_2}{n} \text{ cosec } \theta = \frac{36}{9} \times 1.414 = 5.66 \text{ tons.}$$

$$\frac{W_1 + W_2}{n} \text{ cot } \theta = \frac{48}{9} \times 1 = 5.32 \text{ tons.}$$

The stress in the vertical end post 1 is the vertical component of stress in the brace 1

$$\begin{aligned} &= \text{stress in tie 1} \times \sin \theta = 151 \times 0.707 \\ &= 106.76 \text{ tons.} \end{aligned}$$

Check by moments.

Stress in bay 4-5 of top chord = stress in bay 4-6 + stress in bay 3-5

$$= 2 \times \text{stress in bay 3-5.}$$

The reaction at *O* due to loads at joints 2, 4, 6, 8 is

$$R = \frac{(1 + 3 + 5 + 7) \text{ bays (48) tons}}{9 \text{ bays}}$$

$$= 85.3 \text{ tons.}$$

Taking moments about bottom joint 4.

$$M = 85.3 \text{ tons} \times 4 \text{ bays} - 48 \text{ tons} \times 2 \text{ bays}$$

$$= 245.2 \text{ bay tons.}$$

Since the depth of girder = 1 bay

$$\text{Stress in bay 3-5} = \frac{245.2}{1} = 245.2 \text{ tons compression.}$$

The stress in bay 4-6 of the top chord due to loads at 1, 3, 5, 7 is the same.

Therefore stress in bay 4-5 of top chord is

$$2 \times 245.2 = 490.4 \text{ tons.}$$

CHAPTER V.

GIRDERS WITH PARALLEL CHORDS—GENERAL METHOD— DEAD AND LIVE LOADS CONSIDERED SEPARATELY.

The stresses due to *dead load* only are considered in this chapter. For the stresses due to *live load* see Chapter VII., in which the live load stresses are worked out for a curved girder, the only differences between the two cases being that in the curved girder the depths vary, and the members of top chord member are inclined. In the parallel girders of this chapter both chords are *horizontal* and the depth is *constant*.

35. Dead load considered separately.

The dead load on a bridge consists of the weight of the two main girders, and the weight of the platform load, which includes the cross girders, stringers, flooring, rails, sleepers, and fastenings. One half the weight of *each* main girder is assumed to be distributed at the panel points of the upper chord, and one half at the panel points of the lower chord.

One half the platform load is taken as distributed at the panel points of the chord (upper or lower) which carries this load.

Let W = total weight of *one* main girder.

„ w = weight per foot run of platform load.

„ l = length of main girder.

„ n = number of panels.

Then, if the platform load is carried on the lower chord,

Weight at each panel point of the lower chord

$$W_1 = \frac{W}{2n} + \frac{wl}{2n} \dots\dots\dots(1).$$

Weight at each panel point of upper chord

$$W_2 = \frac{W}{2n} \dots\dots\dots(2).$$

Stresses in bracing and chord members due to dead load.

In parallel girders the stress in the chords or flanges is *horizontal*, consequently the *vertical* shearing force can only be

resisted by the vertical component of the stresses in the diagonal braces, and it is the horizontal components of the same stresses which produce the increment of chord stress at each panel point.

Bracing.—Let θ = inclination of inclined braces to horizontal.

First determine the shearing force in each panel. The shearing force in any panel is the vertical component of stress in the inclined brace in that panel.

The stress in the inclined brace = the shearing force \times cosec θ .

In Fig. 44, $S = V \text{ cosec } \theta$.

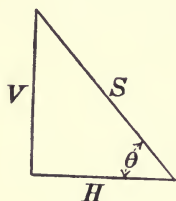

Fig. 44.

The stress in vertical is got by considering the vertical equilibrium of the forces acting on the joint at either of its ends.

Chord members or bays.

The horizontal component of stress in an inclined brace is equal to the vertical component of stress \times cot θ .

In Fig. 44, $H = V \cot \theta$.

The stress in any bay is the sum of the horizontal components of stress in all the inclined braces between one end of the girder and the bay in question.

Working from one end of girder towards the centre, at each panel point an increment of chord stress is added equal to the horizontal component of stress in the inclined brace or braces which meet the chord at that panel point.

The following examples illustrate the method. The results are tabulated, but with numerical examples the results can often be more conveniently written on a line diagram of the girder.

EXAMPLES.

1. A Pratt or N truss of 8 panels (Fig. 45) carries a load $\frac{1}{2}W_1$ at each panel point of the lower chord, and a load W_2 at the panel

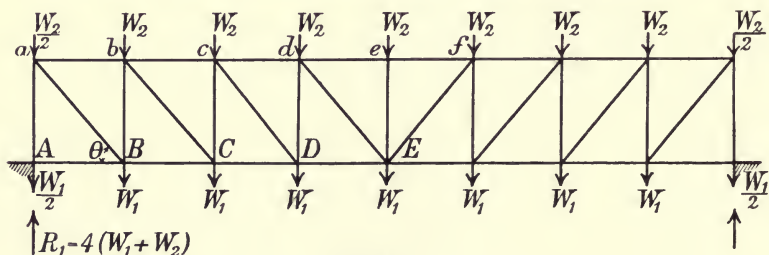

Fig. 45.

points of upper chord. Determine the stresses in bracing and chord members.

The diagonal members of bracing are ties ; the verticals are struts. The upper chord is in compression, and the lower chord in tension.

The stress in any vertical is the vertical component of stress in the diagonal brace to which it is joined at the upper chord plus the load W_2 on top of vertical. The girder being symmetrical, it is only necessary to find the stresses in one half.

Diagonal Brace	BRACING			
	Shearing Force = Vertical Components of Stress	Stress in Brace	VERTICALS	
			No.	Stress
aB	$3\frac{1}{2}(W_1 + W_2)$	$3\frac{1}{2}(W_1 + W_2) \operatorname{cosec} \theta$	aA	$3\frac{1}{2}W_1 + 4W_2$
bC	$2\frac{1}{2}(W_1 + W_2)$	$2\frac{1}{2}(W_1 + W_2) \operatorname{cosec} \theta$	bB	$2\frac{1}{2}W_1 + 3\frac{1}{2}W_2$
cD	$1\frac{1}{2}(W_1 + W_2)$	$1\frac{1}{2}(W_1 + W_2) \operatorname{cosec} \theta$	cC	$1\frac{1}{2}W_1 + 2\frac{1}{2}W_2$
dE	$\frac{1}{2}(W_1 + W_2)$	$\frac{1}{2}(W_1 + W_2) \operatorname{cosec} \theta$	dD	$\frac{1}{2}W_1 + 1\frac{1}{2}W_2$
			eE	W_2

Diagonal Brace	CHORDS			
	Horizontal Components of Stress	Stress	No. of Bay	
			Upper Chord	Lower Chord
		0	..	AB
aB	$3\frac{1}{2}(W_1 + W_2) \cot \theta$	$3\frac{1}{2}(W_1 + W_2) \cot \theta$	ab	BC
bC	$2\frac{1}{2}(W_1 + W_2) \cot \theta$	$6(W_1 + W_2) \cot \theta$	bc	CD
cD	$1\frac{1}{2}(W_1 + W_2) \cot \theta$	$7\frac{1}{2}(W_1 + W_2) \cot \theta$	cd	DE
eE	$\frac{1}{2}(W_1 + W_2) \cot \theta$	$8(W_1 + W_2) \cot \theta$	def	..

2. A Pratt truss (Fig. 46), 112 feet span, depth 12 feet, is divided into 12 panels, each of length 16 feet. The weight of the two main girders is 84 tons, and the weight of the platform load carried on the lower chord is 0.6 ton per foot run. Determine the dead load stresses in the bracing and chord members.

The girder being symmetrical, and symmetrically loaded only one half of the girder is shown in Fig. 46.

The weight of one main girder = $\frac{84}{2} = 42$ tons.

Assuming this weight to be equally distributed at the panel points of upper and lower chords.

Weight at each panel point of upper chord = $\frac{42}{2 \times 7} = 3$ tons.

Weight at each panel point of lower chord = 3 tons.

Platform load carried at panel points of lower chord

$$= \frac{wl}{2n} = \frac{0.6 \times 112}{2 \times 7} = 4.8 \text{ tons.}$$

Therefore total load at each panel point of upper chord = 3 tons; total load at each panel point of lower chord = 3 + 4.8 = 7.8 tons.

$$\operatorname{cosec} \theta = \frac{20}{12} = \frac{5}{3}. \quad \cot \theta = \frac{16}{12} = \frac{4}{3}.$$

Reaction at each support = $\frac{1}{2} (54.6 + 21) = 37.8$ tons.

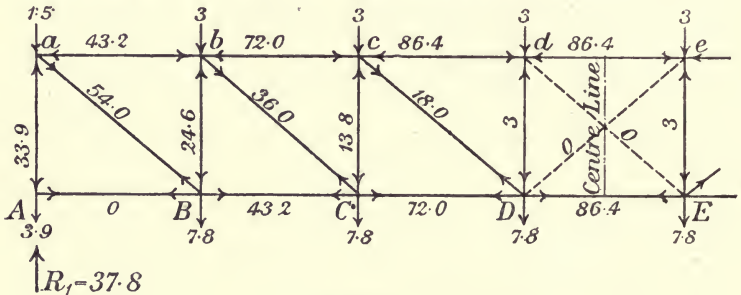

Fig. 46.

BRACING					CHORDS			
Inclined Brace	Shear Force Vertical Component of Stress	Stress in Inclined Brace	Verticals		Horizontal Components of Stress	Stress	Bay	
			No.	Stress			Upper Chord	Lower Chord
			Tons				Tons	
aB	32.4	$32.4 \times \frac{5}{3} = 54$	aA	$32.4 + 1.5 = 33.9$	$32.4 \times \frac{4}{3} = 43.2$	0	...	AB
bC	21.6	$21.6 \times \frac{5}{3} = 36$	bB	$21.6 + 3 = 24.6$	$21.6 \times \frac{4}{3} = 28.8$	43.2	ab	BC
cD	10.8	$10.8 \times \frac{5}{3} = 18$	cC	$10.8 + 3 = 13.8$	$10.8 \times \frac{4}{3} = 14.4$	72.0	bc	CD
dE	0	0	dD	$0 + 3 = 3$	0	86.4	cd	DE
						86.4	de	...

The stresses are obtained as shown in accompanying table, and are entered on the line diagram of girder (Fig. 46). The inclined

braces are in tension; the verticals in compression. The upper chord is in compression; the lower chord in tension.

3. A Warren girder bridge of 120 feet span (Fig. 47), with equilateral bracing and the lower chord divided into 8 bays each 15 feet long, carries a dead load consisting of the weight of two main girders 89.6 tons, and a platform load of 0.64 ton per foot run. Determine the stresses in bracing and chords.

The platform load is carried on the lower chord.

Weight of one main girder = $\frac{89.6}{2} = 44.8$ tons.

Load at each panel point of upper chord, Equation (2),

$$W_2 = \frac{44.8}{2 \times 8} = 2.8 \text{ tons.}$$

In distributing the loads each panel point is assumed to take the load on half a bay on each side of it. Hence, on the upper chord the load at joint $a = \frac{3}{4} 2.8 = 2.1$ tons, and at joint A the load is $\frac{1}{4} 2.8 = 0.7$ ton.

Load at each panel point of lower chord, Equation (1),

$$W_1 = \frac{44.8}{2 \times 8} + \frac{0.64 \times 120}{2 \times 8} = 7.6 \text{ tons.}$$

$$\theta = 60^\circ; \operatorname{cosec} \theta = 1.16; \cot \theta = 0.58.$$

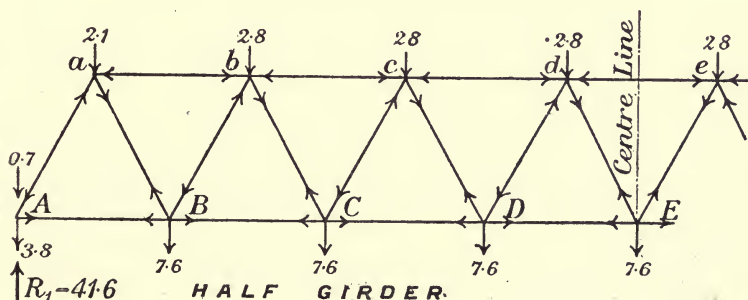

Fig. 47.

The stresses are obtained as shown in table.

If F = shearing force on a vertical section cutting any inclined brace, the stress in that brace is

$$F \operatorname{cosec} \theta.$$

And the stress in any bay of either chord is the sum of the horizontal components of stress of all the inclined braces between

the left support and the bay in question. The braces aA , bB , cC , dD sloping downwards towards the nearest support are struts; and the braces aB , bC , cD , dE sloping downwards towards the centre are ties. The upper chord is in compression, the lower chord in tension.

BRACING			CHORDS				
Inclined Brace	Shear Force Vertical Component of Stress	Stress in Brace	Horizontal Com- ponent of Stress in Brace	Lower Chord		Upper Chord	
				No.	Stress	No.	Stress
		Tons	Tons		Tons		Tons
aA	37.1	$37.1 \times 1.16 = 43.0$	$37.1 \times .58 = 21.5$	AB	21.5
aB	35.0	$35.0 \times 1.16 = 40.6$	$35.0 \times .58 = 20.3$	ab	41.8
bB	27.4	$27.4 \times 1.16 = 31.8$	$27.4 \times .58 = 15.9$	BC	57.7
bC	24.6	$24.6 \times 1.16 = 28.5$	$24.6 \times .58 = 14.3$	bc	72.0
cC	17.0	$17.0 \times 1.16 = 19.7$	$17.0 \times .58 = 9.9$	CD	81.9
cD	14.2	$14.2 \times 1.16 = 16.5$	$15.2 \times .58 = 8.2$	cd	90.1
dD	6.6	$6.6 \times 1.16 = 7.7$	$6.6 \times .58 = 3.8$	DE	98.9
dE	3.8	$3.8 \times 1.16 = 4.4$	$3.8 \times .58 = 2.2$	de	96.1

4. The main girders of a bridge, 120 feet span, are divided into six equal panel lengths of 20 feet by triangular bracing (Figs. 48 and 49). The depth of the girders is 12 feet. The weight of the two main girders is 96 tons, and the platform load weighs 0.6 ton per foot run. Determine the stresses in bracing and chords of one main girder.

In this example the two types of girder shown in half elevation in Figs. 48 and 49 are taken together, one being the inverted form of the other. The platform load in Fig. 48 is carried on the upper chord; in Fig. 49 it is carried on the lower chord.

The stresses in corresponding members of the bracing and chords for the two cases are equal in magnitude but opposite in sense.

The verticals subdivide the bays of the chord which carries the platform load into half bays, so that the length of the stringers is reduced.

$$\text{Weight of one main girder} = \frac{96}{2} = 48 \text{ tons.}$$

$$\text{Total load distributed on the chord not carrying the platform load} = \frac{48}{2} = 24 \text{ tons.}$$

$$\text{Total load distributed on the chord carrying the platform load} = 24 \text{ tons} + \frac{0.6 \times 120}{2} \text{ tons} = 60 \text{ tons.}$$

These loads are distributed on the assumption that each joint

takes half the load between the two adjoining joints on each side of it.

$$\operatorname{cosec} \theta = 1.3 ; \cot \theta = \frac{5}{6}$$

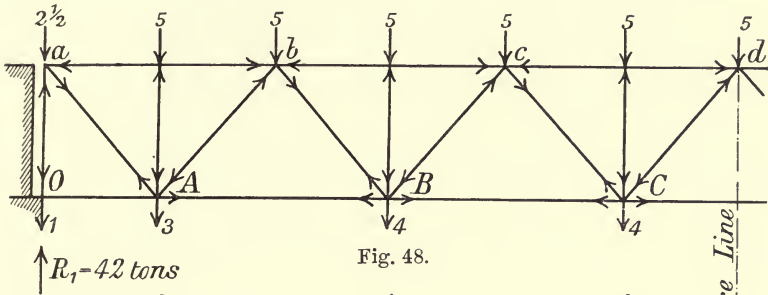

Fig. 48.

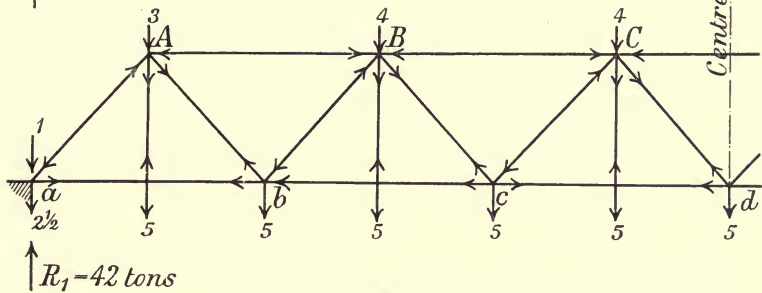

Fig. 49.

The stresses are worked out in table below.

BRACING			CHORDS		
Inclined Brace	Shear Force Vertical Component of Stress	Stress in Inclined Brace	Horizontal Components of Stress	No. of Bay	Stress
		Tons			Tons
<i>aA</i>	38.5	$38.5 \times 1.3 = 50.0$	$38.5 \times \frac{5}{6} = 32.1$	<i>ab</i>	32.1
<i>bA</i>	30.5	$30.5 \times 1.3 = 39.6$	$30.5 \times \frac{5}{6} = 25.4$	<i>AB</i>	57.5
<i>bB</i>	25.5	$25.5 \times 1.3 = 33.2$	$25.5 \times \frac{5}{6} = 21.3$	<i>bc</i>	78.8
<i>cB</i>	16.5	$16.5 \times 1.3 = 21.5$	$16.5 \times \frac{5}{6} = 13.8$	<i>BC</i>	92.6
<i>cC</i>	11.5	$11.5 \times 1.3 = 15.0$	$11.5 \times \frac{5}{6} = 9.6$	<i>cd</i>	102.2
<i>dC</i>	2.5	$2.5 \times 1.3 = 3.3$	$2.5 \times \frac{5}{6} = 2.1$	<i>CD</i>	104.3

Compressive stress in end vertical post = 41 tons.

Stress in verticals = 5 tons, compressive in Fig. 48, tensile in Fig. 49.

Stress in bay *OA*, Fig. 48, is nil.

Upper chord is in compression, lower chord is in tension. Braces sloping downward towards centre are in tension, those sloping upwards towards centre are in compression.

5. Fig. 50 represents the half elevation of a Warren girder with two series of triangulations. The span, 100 feet, is divided into 10 equal bays with web-bracing inclined at 45° . Weight of the two main girders is 96 tons. The platform load carried on the lower chord is 0.72 ton per foot run. Determine the stresses in bracing and chords.

In order to distinguish the two systems of triangulation, one is shown in thin lines; the other in thick lines.

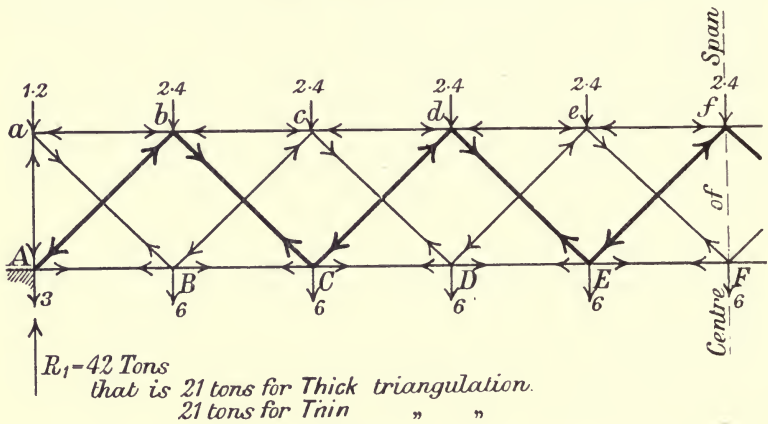

Fig. 50.

To determine the stresses in the bracing, the two systems of triangulation must be regarded as separate from one another. Hence to find the shear force on a vertical section cutting any thin line brace, only the loads on the thin line system must be considered, and similarly for the thick line system.

The stresses in the chords are due to both systems of bracing. Thus the stress in any bay is the sum of the horizontal components of stress in all the braces (thick and thin) between it and the support.

Weight of one main girder = 48 tons.

$$\text{Load at panel points of upper chord} = \frac{48}{2 \times 10} = 2.4 \text{ tons.}$$

Load at panel points of lower chord, Equation (1),

$$= \frac{48}{2 \times 10} + \frac{0.72 \times 100}{2 \times 10} = 6 \text{ tons.}$$

$$\theta = 45^\circ; \text{ cosec } \theta = 1.414; \text{ cot } \theta = 1.$$

BRACING			CHORDS				
Brace	Vertical Component of Stress V	Stress in Brace $V \times 1.414$	Horizontal Component of Stress $V \times 1$	Stress			
				Upper Chord		Lower Chord	
	Tons	Tons	Tons	Tons		Tons	
<i>aB</i>	19.8	27.0	19.8	<i>ab</i>	= 19.8	<i>AB</i>	= 18.0
<i>Ab</i>	18.0	25.5	18.0	<i>bc</i>	$19.8 + 18.0 + 15.6 = 53.4$	<i>BC</i>	$18.0 + 9.8 + 13.8 = 51.6$
<i>bC</i>	15.6	22.1	15.6	<i>cd</i>	$53.4 + 13.8 + 11.4 = 78.6$	<i>CD</i>	$51.6 + 15.6 + 9.6 = 76.8$
<i>Bc</i>	13.8	19.5	13.8	<i>de</i>	$78.6 + 9.6 + 7.2 = 95.4$	<i>DE</i>	$76.8 + 11.4 + 5.4 = 93.6$
<i>cD</i>	11.4	16.2	11.4	<i>ef</i>	$95.4 + 5.4 + 3.0 = 103.8$	<i>EF</i>	$93.6 + 7.2 + 1.2 = 101.8$
<i>Cd</i>	9.6	13.6	9.6				
<i>dE</i>	7.2	10.2	7.2				
<i>De</i>	5.4	7.6	5.4				
<i>eF</i>	3.0	4.3	3.0				
<i>Ef</i>	1.2	1.7	1.2				

6. A bridge, 175 feet span, the two main girders of which are formed of double triangulation of the Pratt or N type, and known as the Linville truss, carries a dead load of the weight of two main girders, 168 tons, together with a platform load of 0.64 ton per foot run, which is carried on the lower chord. Determine the stresses in bracing and chords.

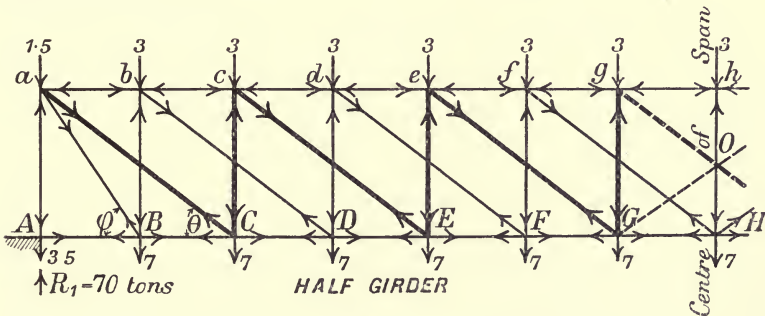

Fig. 51.

The half elevation of girder is shown in Fig. 51. Depth of girder 20 feet; number of panels 14, each 12.5 feet long.
 $\cot \theta = 1.25$; $\operatorname{cosec} \theta = 1.6$.

The brace *aB* in the first panel is at a different inclination ϕ to the others, and

$$\cot \phi = \frac{\cot \theta}{2} = \frac{1.25}{2} = 0.625.$$

Weight of one main girder = 84 tons.

Load at each panel point of upper chord = $\frac{84}{2 \times 14} = 3$ tons.



Load at each panel point of lower chord, Equation (1),

$$= \frac{0.64 \times 175}{2 \times 14} + \frac{84}{2 \times 14} = 7 \text{ tons.}$$

The two systems of triangulation are shown in Fig. 51; one drawn in thin lines, the other in thick lines.

In determining the stresses in the *bracing*, each component girder or system must be considered as separate from the other, and for the loads only which rest on its own panel points.

The stresses in the chords are due to both systems of bracing.

The stress in each vertical is the vertical component of stress in the brace which meets it at the top chord plus the load carried at its upper end.

The vertical component of stress in the inclined brace *aB* of first panel is the stress in the vertical *bB* to which it is connected at lower chord plus the load of 7 tons at foot of vertical

$$= 28 + 7 = 35 \text{ tons.}$$

The horizontal component of stress in the inclined brace *aB*

$$\begin{aligned} &= \text{vertical component} \times \cot \phi \\ &= 35 \times 0.625 = 21.9 \text{ tons.} \end{aligned}$$

BRACING					CHORDS			
Inclined Brace	Vertical Component of Stress V	Stress in Brace V x 1.6	Verticals		Horizontal Component of Stress V x 1.25	Stress	Upper Chord	Lower Chord
			No.	Stress				
	Tons	Tons		Tons		Tons		
<i>aB</i>	35	56			21.9	21.9		<i>BC</i>
<i>aC</i>	30	48	<i>aA</i>	$35 + 30 + 1\frac{1}{2} = 66\frac{1}{2}$	37.5	$21.9 + 37.5 = 59.4$	<i>ab</i>	<i>CD</i>
<i>bD</i>	25	40	<i>bB</i>	$25 + 8 = 28$	31.3	$59.4 + 31.3 = 90.7$	<i>bc</i>	<i>DE</i>
<i>cE</i>	20	32	<i>cC</i>	$20 + 3 = 23$	25.0	$90.7 + 25.0 = 115.7$	<i>cd</i>	<i>EF</i>
<i>dF</i>	15	24	<i>dD</i>	$15 + 3 = 18$	18.8	$115.7 + 18.8 = 134.5$	<i>de</i>	<i>FG</i>
<i>eG</i>	10	16	<i>eE</i>	$10 + 3 = 13$	12.5	$134.5 + 12.5 = 147.0$	<i>ef</i>	<i>GH</i>
<i>fH</i>	5	8	<i>fF</i>	$5 + 3 = 8$	6.3	$147.0 + 6.3 = 153.3$	<i>fg</i>	...
<i>gO</i>	0	0	<i>gG</i>	$0 + 3 = 3$	0	$153.3 + 0 = 153.3$	<i>gh</i>	...
			<i>hH</i>	$3 = 3$				

There is no stress in *AB* of lower chord.

7. Fig. 52 represents the half elevation of a Whipple truss, span 240 feet, divided into 20 bays, each 12 feet long. Depth 24 feet. If the weight of the two main girders is 192 tons and the platform load carried on lower chord weighs 0.7 ton per foot run, find the stresses in chords and bracing.

This girder is similar in form to the Linville truss in last example, except that there are sloping strut members at the ends.

Weight of one main girder = 96 tons.

Load at each panel point of upper chord = $\frac{96}{2 \times 20} = 2.4$ tons.

Load at each panel point of lower chord, Equation (1),

$$= \frac{96}{2 \times 20} + \frac{0.7 \times 240}{2 \times 20} = 6.8 \text{ tons.}$$

In this case $\theta = 45^\circ$; $\cot \theta = 1$; $\text{cosec} = 1.414$.

$$\cot \phi = \frac{1}{2} \cot \theta = \frac{1}{2}.$$

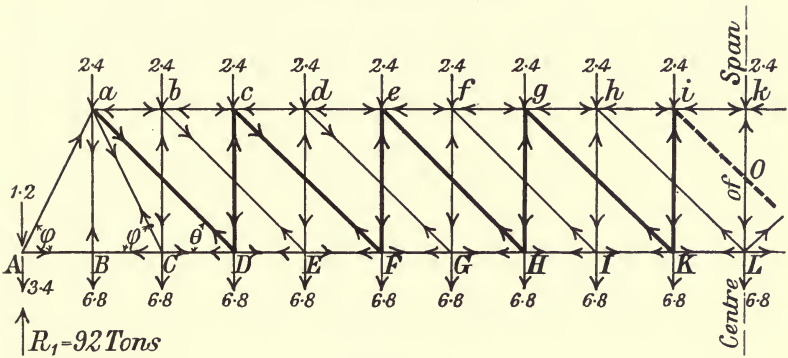

Fig. 52.

BRACING				CHORDS				
Inclined Brace	Vertical Component of Stress = V	Stress in Inclined Brace V x 1.414	Verticals		Horizontal Component of Stress V x 1	Stress	Upper Chord	Lower Chord
			No.	Stress				
aA	87.4	123.6		Tons	43.7*			AC
aC	41.4	58.6			20.7†			CD
aD	36.8	52.0	aB	= 6.8	36.8	43.7 + 20.7 =	64.4	DE
bE	32.2	45.6	bC	32.2 + 2.4 =	32.2	101.2 + 32.2 =	133.4	EF
cF	27.6	37.0	cD	27.6 + 2.4 =	27.6	133.4 + 27.6 =	161.0	FG
dG	23.0	32.5	dE	23.0 + 2.4 =	23.0	161.0 + 23.0 =	184.0	GH
eH	18.4	26.0	eF	18.4 + 2.4 =	18.4	184.0 + 18.4 =	202.4	HI
fI	13.8	19.5	fG	13.8 + 2.4 =	13.8	202.4 + 13.8 =	216.2	IK
gK	9.2	13.0	gH	9.2 + 2.4 =	9.2	216.2 + 9.2 =	225.4	KL
hL	4.6	6.5	hI	4.6 + 2.4 =	4.6	225.4 + 4.6 =	230.0	...
iO	0	0	iK	0 + 2.4 =	0	230.0 + 0 =	230.0	...
			kL	2.4				

* Horizontal component in aA = $87.4 \times \cot \phi = \frac{87.4}{2} = 43.7$ tons.

† Horizontal component in aC = $41.4 \times \cot \phi = \frac{41.4}{2} = 20.7$ tons.

As in last example, each system or separate girder with its own loads must be taken separately for finding the stresses in the braces, whereas both systems of bracing contribute to the stresses in the chords.

The vertical component of stress in first inclined brace aA = the sum of the vertical components of stress in aD , aC , and $aB = 36.8 + 41.4 + 9.2 = 87.4$ tons.

The chord stress in first bay ab of upper chord = sum of the horizontal components of stress in aA , aC and $aD = 43.7 + 20.7 + 36.8 = 101.2$ tons. The stress in all verticals is compressive, except that in aB which is tensile and equals 6.8 tons, the load at its foot.

The stresses required are worked out in table on preceding page.

CHAPTER VI.

PARABOLIC GIRDERS.

36. Parabolic girders.

In a parabolic girder the upper or compression chord is a polygon inscribed in a parabola, which is the curve of bending moment. The lower chord is straight, subject only to tension. The bracing, or web members, consists of verticals dividing the span into bays of equal length, together with either one set of diagonal braces, in each of which both compressive and tensile stress may occur, according to the position of the live load; or with two sets diagonal braces crossing one another, in which only tensile stress can occur.

Fig. 53 represents a girder of single triangulation; the form of the upper chord is that of the bending moment curve, the girder being uniformly loaded.

Let M = bending moment at a vertical section.

„ y = the ordinate of the axis of upper chord at the same section—that is, the ordinate of the moment curve.

„ F = shearing force on same section.

„ l = length of span.

„ ϕ = angle of inclination with the horizontal of that bay of upper chord cut by the section.

„ H = stress in that bay of the lower chord cut by section, which is also the horizontal component of the inclined stress in the curved chord; these two forming a couple with arm y , which constitutes the moment of resistance.

Then

$$M = Hy.$$

But M is proportional to the ordinate y of the moment curve. Hence H is constant.

Taking moments about the centre of upper chord, and calling y_c the centre ordinate or depth,

$$H = \frac{wl^2}{8y_c} \dots\dots\dots(1).$$

Again

$$F = \frac{dM}{dx} = H \frac{dy}{dx} = H \tan \phi,$$

but $H \tan \phi$ is the vertical component of stress in the bay of curved chord cut by section. Therefore this vertical component balances the shearing force, and the diagonal brace is unstrained.

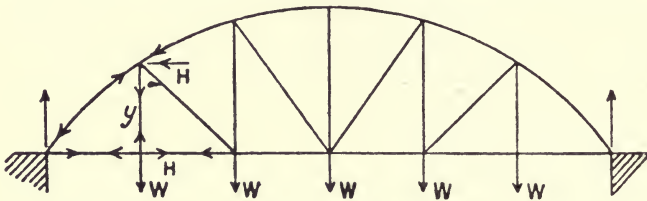

Fig. 53.

No stress, therefore, occurs in the diagonal braces of the web when the girder is uniformly loaded. Hence in such a girder subject only to a uniform dead load the diagonal bracing may be omitted.

The stress in the bay of curved chord at section

$$S = H \sec \phi \dots\dots\dots(2);$$

that is, the stress is proportional to the inclined length of the bay, since the horizontal length is constant.

37. Depths of girder at the panel points. Inclinations of bays of polygonal chord and diagonal braces.

Let n = number of equal bays in the straight chord.

„ y_c = depth of girder between the axes of chords at the centre of span in bay units.

„ y_r = the depth at the end of the r^{th} bay nearest the centre.

„ ϕ_r = the angle of inclination of the r^{th} bay of the polygonal chord with horizontal.

„ θ_r = inclination to the horizontal of diagonal r .

„ W = total of dead and live loads *per bay*, applied at each panel point of the straight chord.

A bay is taken as the unit of length.

The method of numbering the different members of the girder is clearly shown in Fig. 54. The following proofs are taken

generally for the r^{th} member of chords and bracing ; consequently the results can be applied to any member desired. These proofs are rather lengthy, but the formulæ derived are simple and easily applied.

The bending moment at the centre of the span is

$$M_c = \frac{Wn^2}{8} \text{ bay units} \dots\dots\dots(3).$$

The bending moment at the end of the r^{th} bay is

$$M_r = \frac{W}{2} r (n-r) \dots\dots\dots(4).$$

Now, the depths being proportional to the bending moments,

$$\frac{y_r}{y_c} = \frac{M_r}{M_c} = \frac{\frac{r(n-r)}{2}}{\frac{n^2}{8}} = 4 \frac{r(n-r)}{n^2}.$$

Therefore
$$y_r = 4 \frac{r(n-r)}{n^2} y_c \dots\dots\dots(5).$$

From this equation the depths of the girder at the end of each bay can be found when the central depth is given.

If H = horizontal component of stress in polygonal chord due to the dead and live loads covering the whole span,

The stress in bay r of the polygonal chord is

$$S_r = H \sec \phi_r.$$

Inclination of bays of polygonal chord.

Now,
$$\begin{aligned} \tan \phi_r &= \frac{y_r - y_{r-1}}{1 \text{ bay}} = \frac{1}{H} (M_r - M_{r-1}) \\ &= \frac{W}{2H} \{ r(n-r) - (r-1)(n-r+1) \} \\ &= \frac{W}{2H} (n-2r+1). \quad \text{Or since } H = \frac{Wn^2}{8y_c} \\ &= \frac{4}{n^2} (n-2r+1) y_c \dots\dots\dots(6), \end{aligned}$$

and
$$\sec \phi_r = \sqrt{1 + \tan^2 \phi_r}.$$

Inclination of diagonals.

$$\tan \theta_r = y_r$$

and
$$\sec \theta_r = \sqrt{1 + y_r^2}$$

38. Maximum stress in the members of a parabolic girder.

Chords.

Fig. 54 represents a parabolic girder with web of single triangulation.

The maximum stress in chords occurs when the whole span is fully loaded with dead and live loads. Also the horizontal component of stress in the chords is constant.

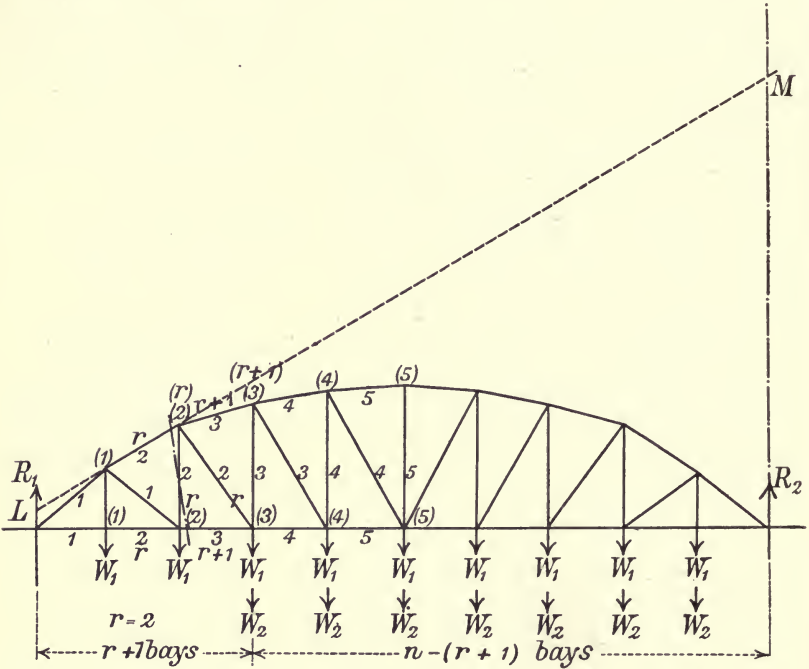

Fig. 54.

To find the maximum stress in any member of the polygonal chord, say, the r^{th} bay.

Produce the bay r of upper chord to meet the verticals drawn through the two supports at L and M , then

$$LM = l \sec \phi_r \dots\dots\dots(7),$$

where l = length of the girder.

But we have previously shown that the stress in bay r

$$S_r = H \sec \phi_r \dots\dots\dots(8).$$

Therefore, from (7) and (8) we see that the intercept LM repre-

sents the total stress in bay r of polygonal chord on the same scale that l represents the horizontal component,

$$H = \frac{wl^2}{8y_c},$$

w being the sum of the intensities of the uniform dead and live loads.

39. Web-bracing.

Let W_1 = dead load carried at each joint of the straight chord.

„ W_2 = live „ „ „ „ „ „ „

„ compressive and tensile stress be positive and negative respectively.

Dead load.

By Art. 36,

Stress in each diagonal brace = 0.

Stress in each vertical = $-W_1$ tension.

Live load.

To determine the maximum tension in diagonals r , and maximum compression in vertical r in left-hand half of the span.

Let F_r = vertical shearing force on left side of an approximately vertical section cutting the $(r+1)^{\text{th}}$ bay of straight chord, and the r^{th} vertical.

„ H_r, H_{r+1} = horizontal components of stress in the r^{th} and $(r+1)^{\text{th}}$ bays of the polygonal chord due to partial live load specified.

„ y_r, y_{r+1} = depths of girder at joints $r, r+1$ respectively.

Take a bay as the unit of length.

The maximum stresses required occur when the lower joint $r+1$ and all the joints to the right are loaded.

Then F_r = reaction at left support.

$$\begin{aligned} &= \frac{W_2}{n} \{ n - (r+1) + \dots + 1 \} \\ &= \frac{W_2}{2n} (n-r)(n-r-1) \dots \dots \dots (9). \end{aligned}$$

The horizontal component of stress in diagonal r

$$= \frac{M_r}{y_r} - \frac{M_{r+1}}{y_{r+1}} = F_r \left(\frac{r}{y_r} - \frac{r+1}{y_{r+1}} \right) \dots \dots \dots (10).$$

By Equation (5)

$$y_r = \frac{4}{n^2} r (n-r) y_c; \text{ and } y_{r+1} = \frac{4}{n^2} (r+1)(n-r-1) y_c.$$

Substituting these values in (10), and for F_r from (9) we get
Maximum horizontal component of stress in diagonal r

$$\begin{aligned} &= \frac{W_2}{2n} (n-r) (n-r-1) \cdot \left\{ \frac{1}{n-r} - \frac{1}{n-r-1} \right\} \frac{n^2}{4y_c} \\ &= -\frac{W_2 n}{8y_c} \dots\dots\dots(11). \end{aligned}$$

Maximum tensile stress in diagonal r

$$= -\frac{W_2 n}{8y_c} \sec \theta_r \text{ tension } \dots\dots(12).$$

The length of diagonal being proportional to $\sec \theta_r$, we see that the stress in any diagonal is proportional to its length, and that its horizontal component is constant and $= W_2 \frac{n}{8y_c}$.

To find the stress in diagonal r graphically.

Since the horizontal component of stress in the chords, when the girder is fully loaded with the live load, is

$$H = \frac{W_2 n^2}{8y_c}$$

we see from (11) that

The maximum horizontal component of stress in any inclined brace

$$= \frac{H}{n}.$$

Now the horizontal projection of any brace

$$= \frac{l}{n}.$$

Therefore, *the actual length of each brace represents the maximum stress in it, on the same scale that l represents the horizontal component of stress (H), the girder being fully loaded with the live load.*

Maximum compressive stress in vertical r .

Considering the vertical equilibrium of the segment on the left of an approximately vertical section cutting the vertical r and the r^{th} bay of polygonal chord.

Maximum compressive stress in vertical r

$$\begin{aligned} &= F_r - H_r \tan \phi_r \\ &= F_r \left\{ 1 - \frac{r}{y_r} \tan \phi_r \right\} \end{aligned}$$

Substituting for $\tan \phi_r$ from Equation (11), and for F_r from Equation (9).

Maximum compressive stress in vertical r

$$\begin{aligned}
 &= \frac{W_2}{2n} (n-r) (n-r-1) \left\{ 1 - \frac{n-2r+1}{n-r} \right\} \\
 &= \frac{W_2}{2n} (r-1) (n-r-1) \text{ compression } \dots\dots\dots(13).
 \end{aligned}$$

To find the maximum compressive stress in diagonal r , and the maximum tension in vertical r .

When all the joints of the straight chord are loaded by W_2 , the resultant stress in any brace is the algebraic sum of the maximum compressive and tensile stresses. Under such loading we have seen (Art. 36) that there is no stress in the diagonals, and that the tensile stress in each vertical is equal to the load carried at its foot.

Hence

Maximum compression in diagonal r + maximum tension in diagonal $r = 0$.

Therefore by Equation (12)

$$\text{Maximum compression in diagonal } r = \frac{W_2 n}{8y_c} \cdot \sec \theta_r.$$

Again,

Maximum tension in vertical r + maximum compression in vertical $r = -W_2$.

Therefore by Equation (13)

$$\begin{aligned}
 \text{Maximum tension in vertical } r &= -W_2 - \frac{W_2}{2n} (r-1) (n-r-1) \\
 &= -\frac{W_2}{2n} (r+1) (n-r+1) \text{ tension.}
 \end{aligned}$$

Resultant stresses due to both dead and live loads.

Diagonals

$$\frac{W_2 n}{8y_c} \sec \theta_r \text{ tension ; } \frac{W_2 n}{8y_c} \sec \theta_r \text{ compression.}$$

Verticals

$$+ \frac{W_2}{2n} (r-1) (n-r-1) - W_1 ; -\frac{W_2}{2n} (r+1) (n-r-1) - W_1.$$

On the *middle vertical* the stress is tensile, and is equal to the sum of the vertical components of the stresses in the two middle bays of the polygonal chord.

40. Case II.—Web with double triangulation.

In this form of web, in which there are *two* diagonals, crossing one another in each panel, both these diagonal braces are *ties*, and are unaffected by the dead load.

In Fig. 55 all the braces meeting at one joint of the polygonal chord have the same number as the joint, but the numbers of the new diagonals (which slope upwards towards the centre) are dashed. Thus r^1 is the number of the new diagonal meeting the upper joint r .

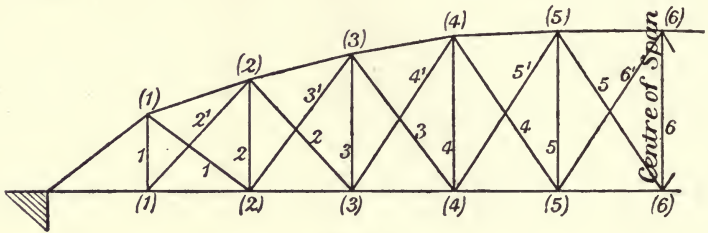

Fig. 55.

STRESSES DUE TO LIVE LOAD.

The maximum tension in diagonal r^1 , and maximum compression in vertical r , occur when the lower joint $(r-1)$ and all joints to the left are loaded with W_2 .

The maximum tension in diagonal r^1 can be shown to be

$$= -\frac{W_2 n}{8y_c} \sec \theta_r,$$

which is the same expression as that for the maximum tension in diagonal r , Equation (12), Art. 39.

So that the maximum tensile stress is the same for the two diagonals meeting at the same joint of polygonal chord.

The maximum compression in vertical r can be shown to be

$$= \frac{W_2}{2n} (r-1) (n-r-1) \text{ compression,}$$

which is the same expression as Equation (13), Art. 39.

Thus the compressive stress on any vertical is a maximum for that distribution of the live load causing maximum tension in either of the diagonals meeting at its upper extremity, and the magnitude of the compressive stress is the same for either condition of loading.

The maximum tension in any vertical due to the live load occurs when the girder is fully loaded, and is $= -W_2$.

STRESSES DUE TO DEAD LOAD.

On any diagonal $= 0$.

On any vertical $= -W_1$.

EXAMPLE.

A parabolic girder of single triangulation (Fig. 54, Art. 38), span 150 feet, divided into ten equal bays of 15 feet, carries a

dead load of 6 tons per bay and a live load of 15 tons per bay. The central depth is 20 feet. Determine (a) the depths at panel points 1, 2, 3, 4, and verify by differences; (b) the maximum stress (H) in the straight chord; (c) the maximum stresses in the second and fifth bays of the polygon chord; (d) the maximum stresses due to the live load occurring in first and fourth diagonals from one support.

Data : $l = 150$ feet ; $n = 10$; bay = 15 feet.

$$y_c = y_5 = 20 \text{ feet} = \frac{4}{3} \text{ bay.}$$

$$W_1 = 6 \text{ tons ; } W_2 = 15 \text{ tons.}$$

$$(a) \quad y_r = 4 \frac{y_c}{n^2} r (n - r). \text{ Equation (5). Art 37.}$$

Second Diffs.	First Diffs.	r	Depths
		1	$y_1 = 4 \times \frac{4}{3} \times \frac{1}{10^2} \times 1 \times 9 = 0.48 \text{ bay} = 7.2 \text{ feet}$
	5.6	2	$y_2 = 4 \times \frac{4}{3} \times \frac{1}{10^2} \times 2 \times 8 = 0.85 \text{ ,,} = 12.8 \text{ ,,}$
1.6	4.0	3	$y_3 = 4 \times \frac{4}{3} \times \frac{1}{10^2} \times 3 \times 7 = 1.12 \text{ ,,} = 16.8 \text{ ,,}$
1.6	2.4	4	$y_4 = 4 \times \frac{4}{3} \times \frac{1}{10^2} \times 4 \times 6 = 1.28 \text{ ,,} = 19.2 \text{ ,,}$
1.6	0.8	5	$y_5 = 4 \times \frac{4}{3} \times \frac{1}{10^2} \times 5 \times 5 = \frac{4}{3} \text{ ,,} = 20 \text{ ,,}$

$$(b) \quad H = \frac{Wn^2}{8y_c} = (6 + 15) \frac{10^2}{8 \times \frac{4}{3}} \text{ bay}$$

$$= \frac{6300}{32} = 196.87 \text{ tons.}$$

(c) To find S_2 and S_5 .

These stresses are a maximum when the girder is fully loaded with both dead and live loads.

$$\text{Now} \quad S_r = H \sec \phi_r$$

$$\text{and} \quad \sec \phi_r = \sqrt{1 + \tan^2 \phi_r}$$

$$= \sqrt{1 + (y_r - y_{r-1})^2}.$$

$$\text{Hence} \quad \sec \phi_2 = \sqrt{1 + (y_2 - y_1)^2} = \sqrt{1 + (0.85 - 0.48)^2}$$

$$= \sqrt{1 - 0.137} = 1.07,$$

$$\sec \phi_5 = \sqrt{1 + (y_3 - y_4)^2} = \sqrt{1.003}$$

$$= 1.0014.$$

Therefore

$$S_2 = 196.87 \times 1.07 = 210 \text{ tons.}$$

$$S_5 = 196.87 \times 1.0014 = 197 \text{ tons.}$$

(d) Let D_1, D_4 be the stresses in diagonals 1 and 4 respectively—

Then

$$\begin{aligned} D_r &= \pm \frac{W_2 n}{8y_c} \sec \theta_r \\ &= \pm \frac{15 \times 10}{8 \times \frac{4}{3}} \sec \theta_r = \pm \frac{450}{32} \sec \theta \\ &= \pm 14.06 \sec \theta_r. \end{aligned}$$

Now $\sec \theta_1 = \sqrt{1 + y_1^2} = \sqrt{1 + 0.48^2} = 1.109,$

$\sec \theta_4 = \sqrt{1 + y_4^2} = \sqrt{1 + 1.28^2} = 1.624,$

Therefore,

$$D_1 = \pm 14.06 \times 1.109 = \pm 15.6 \text{ tons.}$$

$$D_4 = \pm 14.06 \times 1.624 = \pm 22.7 \text{ tons.}$$

The stresses in cases (c) and (d) could be found at once graphically from the frame diagram; as in case (c) the constant horizontal component of stress is 196.87 tons, and in case (d) the constant horizontal component is 14.06 tons.

CHAPTER VII.

CURVED GIRDERS NOT PARABOLIC.

41. Curved girders not parabolic.

In various designs of girders one chord is curved, but its panel points do not lie on a parabolic curve. In these cases the methods of determining the stresses as explained for parabolic girders will not hold good.

The following example illustrates the method of determining the stresses for such a girder due to dead and live loads.

The live load in this case has been taken as a series of axle loads followed by a uniform load.

Example: Data.—Span 130 feet, divided into 8 equal bays, each 16·25 feet long, of the form shown in Fig. 56.

Table of heights at panel points.

B	C	D	E
19	22·4	24·4	25

The bridge is to carry a single line of railway.

LOADS.—*Dead load.*

The total dead load on the bridge is taken as 1·6 ton per foot run uniformly distributed. Of this total 0·7 ton per foot run is due to the weight of the platform, applied at the panel points of lower chord; and 0·9 ton per foot run due to the weight of the two girders and bracing assumed equally applied at the panel points of upper and lower chords.

Thus, at each panel point of the *lower* chord the dead load is

$$\frac{1}{2} (0\cdot7 + 0\cdot45) 16\cdot25 = 0\cdot575 \times 16\cdot25 = 9\cdot34 \text{ tons};$$

at each panel point of the *upper* chord

$$\frac{1}{2} (0\cdot45) 16\cdot25 = 0\cdot225 \times 16\cdot25 = 3\cdot66 \text{ tons.}$$

Live load.

The bridge is to be designed for a live load consisting of two type locomotives, and a train taken as a uniform load of 1.4 ton

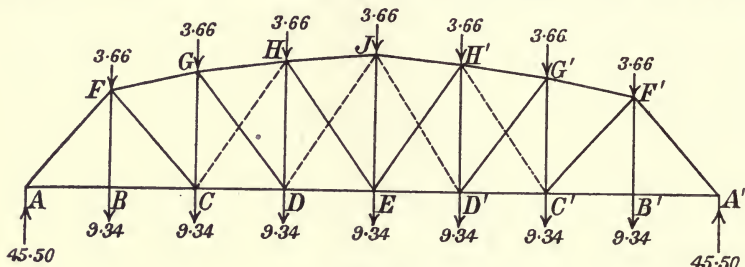

Fig. 56.

per foot run. Each axle of locomotive is assumed to carry 16 tons (Fig. 57).

TYPE OF LOCOMOTIVE.

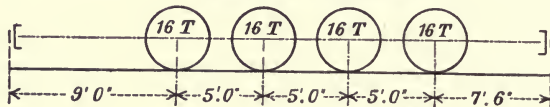

Fig. 57.

STRESSES DUE TO DEAD LOAD.

The distribution of dead load is shown in Fig. 56.

The inclination to horizontal of any one member of upper chord is denoted by ϕ .

The girder and loading being symmetrical, the stresses are tabulated for members on one side of the centre of span only.

Chords.

Panel Point	BM at Panel Point	Depth d	Horizontal Component of Stress $H = \frac{BM}{d}$	Lower Chord		Upper Chord	
				Member	Stress H	Member	Stress $H \sec \phi$
<i>F</i>	Foot-Tons 739.4	Feet 19	Tons 39	<i>AC</i>	39	<i>AF</i>	56
<i>G</i>	1267.5	22.4	57	<i>CD</i>	57	<i>FG</i>	58
<i>H</i>	1584.4	24.4	65	<i>DE</i>	65	<i>GH</i>	66
<i>J</i>	1700	25	68	<i>HJ</i>	68.2

Inclined braces.

The inclination of any one brace to the horizontal is denoted by θ . The horizontal component of stress in any inclined brace

is the difference between the horizontal components of stress in the chord members to right and left of it.

For values of H see table on preceding page.

Inclined Brace	H to Right	H to Left	Difference = Horizontal Component of Stress in Brace h	Total Stress in Inclined Brace $h \sec \theta$
	Tons	Tons	Tons	Tons
<i>FC</i>	57	39	18	27.5
<i>GD</i>	65	57	8	12.6
<i>HE</i>	68	65	3	5.4

These stresses are all tensile.

Verticals.

Considering the vertical equilibrium of the joint at foot of brace. The stress in vertical is equal to the vertical component of stress in inclined brace ($h \tan \theta$) minus the load carried at foot of vertical.

For values of h see last table.

The + sign denotes compression, the - sign denotes tension.

Vertical	<i>FB</i>	<i>GC</i>	<i>HD</i>	<i>JE</i>
$h \tan \theta$	+21.06	+11.04	{ +4.5 +4.5
Load at foot	-9.34	- 9.34	- 9.34	-9.34
Stress in vertical . . .	-9.34	+11.72	+ 1.70	-0.34

Two inclined braces meet at the foot of the centre vertical, in this case the load carried at foot of vertical is to be deducted from the sum of the two vertical components.

The vertical *FB* is a tie, and the stress in it is simply the load carried at its foot, 9.34 tons.

42. Live load stresses.

Maximum bending moments.

In order to determine the stresses in the various members of the girder due to the live load, it is necessary to determine first the maximum bending moments at the panel points. The following method is described in 'The Strength and Elasticity of

Structural Members,' page 128, and is briefly outlined here as applied to a practical example.

The live load is taken to consist of two locomotives (of which the type is shown in Fig. 57) followed by a uniform load of 1.4 ton per foot run.

As the bridge is to be designed for a single track, the axle loads for each girder are $\frac{16}{2} = 8$ tons, and the uniform load $\frac{1.4}{2} = 0.7$ ton per foot run. The axles are taken 5 feet apart, centre to centre; the distance between the two locomotives is $2 \times 7' 6'' = 15$ feet; and the distance from last axle to the head of the uniform load 9 feet.

In Fig. 58, AA^1 is the span, AA^1 is produced to A'' making $A'A''$ equal to the span, and on it are marked the panel points. First take the leading axle immediately over the right-hand support A' (Fig. 58) and draw the bending moment diagram as explained in 'The Strength and Elasticity of Structural Members,' pages 88 and 89. Calculate the moment of each successive load about A the left support, starting with the leading axle load, which is over the right support A' . Set these moments down to scale consecutively on the line Aa , drawn perpendicular to AA^1 . The moments are:—

	Tons	Feet	
$A m_1$	$= 8 \times 130$	$= 1040$	foot tons.
$m_1 m_2$	$= 8 \times 125$	$= 1000$,,
$m_2 m_3$	$= 8 \times 120$	$= 960$,,
$m_3 m_4$	$= 8 \times 115$	$= 920$,,
$m_4 m_5$	$= 8 \times 100$	$= 800$,,
$m_5 m_6$	$= 8 \times 95$	$= 760$,,
$m_6 m_7$	$= 8 \times 90$	$= 720$,,
$m_7 m_8$	$= 8 \times 85$	$= 680$,,
$m_8 a$	$= \frac{0.7 \times 76^2}{2}$	$= 2021.6$,,
		Total = 8901.6	,,

Join $A^1 m_1$ and draw a vertical through the second load to meet $A^1 m_1$ in 2, join $2 m_2$ and draw the vertical through third load to meet it in 3; join $3 m_3$ and draw a vertical through fourth load to meet it in 4, and so on to point 8. Join $8 m_8$ and from this line set down vertical ordinates $\frac{0.7x^2}{2}$ for any convenient values of x measured from P the head of the uniform load. We thus get the curved line $A^1 2348a$. Now join $A^1 a$ and the required moments at the panel points due to the train of loads *when the*

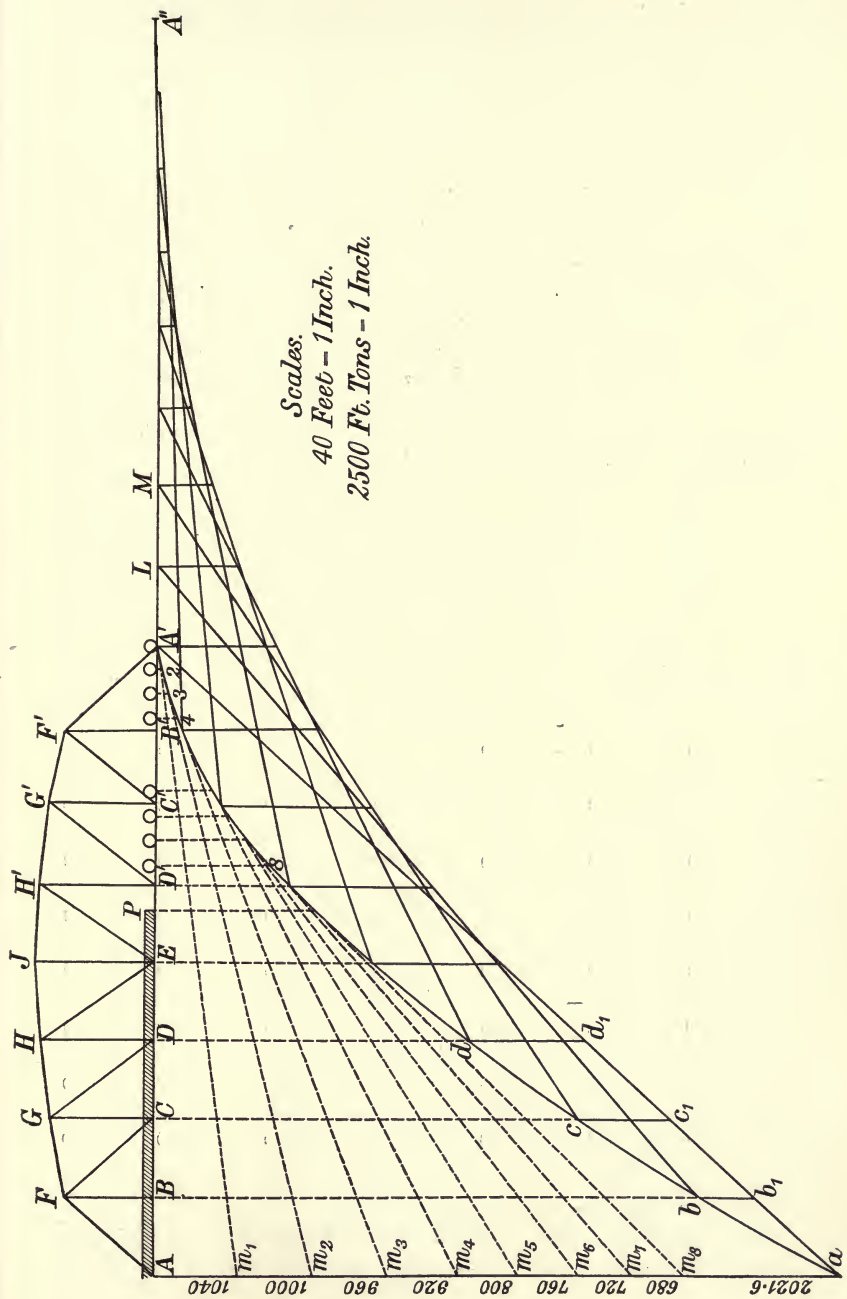

Scales.
 40 Feet - 1 Inch.
 2500 Ft. Tons - 1 Inch.

Fig. 58.

leading axle is at A^1 can be got by measuring the ordinates bb_1 , cc_1 , dd_1 , &c., between the base A^1a and the curved line A^12348a ; the ordinates being drawn vertically below the panel points of girder. That these intercepts between the straight line base and the curved line represent the bending moments is evident since the bending moment at any point is the moment of the reaction minus the moments of the loads.

$$M \text{ at } D = Dd_1 - Dd = dd_1.$$

Leading axle at B^1 .

Now suppose the girder to move forward to the right one panel length. L is the new position of A^1 and the span is represented by LB . As the train is assumed to remain stationary the leading axle is now one panel back from A^1 , that is, is at B^1 . Bb is the moment of the reaction at the right support and the moments of the loads about B are represented by the intercepts on Bb . Join Lb ; then the bending moments for train of loads leading axle being at B^1 are measured by the ordinates under the panel points, between the new base Lb and the curved line LA^1248b .

The curved line of moments for the downward forces serves for every position of the train of loads.

Leading Axle at	BENDING MOMENTS AT PANEL POINTS						
	B	C	D	E	D^1	C^1	B^1
A^1	750	1,150	1,500	1,650	1,680	1,430	825
B^1	700	1,250	1,625	1,800	1,850	1,500	1,000
C^1	750	1,350	1,750	2,000	1,750	<u>1,350</u>	<u>750</u>
D^1	750	1,375	1,675	1,750	<u>1,400</u>	<u>900</u>	440
E	950	1,200	1,450	<u>1,410</u>	<u>1,050</u>	700	350
D	660	950	<u>1,080</u>	<u>870</u>	660	450	220
C	460	<u>680</u>	<u>570</u>	460	350	230	120
B	<u>350</u>	<u>300</u>	250	200	150	100	50

Leading axle at C^1 .

Again, assume the girder to move forward another panel length so that A^1 comes to M . MC is now the span, and the

train being stationary the leading axle is over C^1 . The bending moments as before are got by measuring the ordinates vertically below the panel points from the new base M_c to the curved line of moments, MLA^{1248c} . This process is continued until the leading axle finally comes over the left support A —that is, the train has moved off the bridge.

The bending moments at the several panel points as obtained by scale for the different positions of the live load are given in the table on the preceding page, and the method of obtaining the stresses in the girder from these bending moments will now be explained.

43. Live load stresses.

Maximum stresses in chord members.

The maximum bending moments are taken from the previous table.

Thus, in column E the maximum moment is 2,000 feet tons.

In columns D and D^1 " " 1,850 " "

In columns C and C^1 " " 1,500 " "

In columns B and B^1 " " 1,000 " "

The girder being symmetrical, and the train liable to pass in either direction over the bridge, the maximum moments for corresponding panel points on each side of the centre are taken.

Table of stresses in chord members for the left half of girder ; corresponding members in the right hand half have like stresses. (Fig. 56.)

Panel Points	Bending Moment M	Panel Depth d	$H = \frac{M}{d}$	Chords			
				Lower	Stress H	Upper	Stress $H \text{ Sec } \phi$
	Ft. Tons	Feet	Tons		Tons		Tons
B, F	1,000	19	52.6	AC	52.6	AF	80.0
C, G	1,500	22.4	67.0	CD	67.0	FG	75.0
D, H	1,850	24.4	75.8	DE	75.8	GH	79.6
E, J	2,000	25	80.0	HJ	80.6

NOTE.—For girders with parallel chords d is constant and $\phi = 0$.

Maximum stresses in inclined braces.

The maximum tension in any inclined brace occurs when the leading axle is at the foot of the brace, the live load covering the longer segment of the bridge from the foot of the brace to the furthest support. The maximum compression in any brace occurs when the leading axle is under the head of the brace, the live load covering the shorter segment of girder to the nearest support.

The maximum horizontal component of stress in any inclined brace is the difference between the maximum horizontal components of stress in the chord members to left and right of it: thus,

The leading axle being taken at the foot of the brace,
The horizontal component of stress in brace

$$= \frac{\text{Moment at foot of brace}}{\text{depth at foot of brace}} - \frac{\text{Moment at head of brace}}{\text{depth at head of brace}}$$

In the accompanying table of stresses the bending moments are taken from the table (Art. 42, page 106) got from the bending moment diagram for live load.

Table of maximum stresses in inclined braces. (Fig. 56.)

	Inclined Brace	Leading Axle at	Horizontal Components of Stress in Braces		Total Stress in Brace $h \sec \theta$
			$\frac{M \text{ at foot}}{d \text{ at foot}}$	$\frac{M \text{ at head}}{d \text{ at head}} = h$	
Braces	F^1C^1	C^1	$\frac{1350}{22.4}$	$\frac{750}{19} = 20.8$	30
	G^1D^1	D^1	$\frac{1400}{24.4}$	$\frac{900}{22.4} = 17.2$	26.5
	H^1E	E	$\frac{1410}{25}$	$\frac{1050}{24.4} = 13.4$	20.8
Counterbraces	JD	D	$\frac{1080}{24.4}$	$\frac{870}{25} = 9.4$	17.6
	HC	C	$\frac{680}{22.4}$	$\frac{570}{24.4} = 7.1$	11.0
	GB	B	$\frac{350}{19}$	$\frac{300}{22.4} = 5.0$	7.2

NOTE.—For girders with parallel chords d is constant.

The above stresses are also those for corresponding braces of the other half of girder; thus the stress in GD is the same as in G^1D^1 . The stresses in braces are tensile.

The stress in JD is the compressive stress in HE .

“ “ HC “ “ “ “ GD .

“ “ GB “ “ “ “ FC .

A counterbrace JD must be used, since the compressive live load stress in HE (17.5 tons) is greater than the tensile dead load

stress in HE (5.4 tons). The compressive live load stress in GD is 11 tons, which is somewhat less than the tensile dead load stress in it, 12.6 tons; but as these stresses are so nearly equal it is advisable to introduce the counterbrace HC . The counterbrace GB is not necessary, as the dead load tensile stress in FC (27.4 tons) is much greater than the live load compressive stress in it (7.2 tons).

In the panels which are counterbraced, both diagonal braces are subject only to tension, one being in action at a time.

Verticals.

Resolving vertically at the intersection of vertical with top chord, the stress in any vertical is equal to the vertical component of stress in upper chord member on the side of vertical towards the centre of span *plus* the vertical component of stress in inclined brace at head of the vertical *minus* the vertical component of stress in chord member on the support side of vertical (Fig. 59).

The maximum stress in any vertical occurs when the brace at its head is transmitting its maximum stress, and the maximum horizontal components of stress in braces is taken from the previous table.

We must first find the horizontal components of stress in the chord members to right and left of each vertical due to the leading axle of train load at the foot of brace which meets the vertical in upper chord.

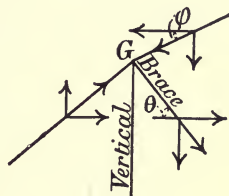

Fig. 59.

Leading Axle at	Horizontal Components of Stress in Chord Members			
	Member	$\frac{BM}{d} = H$	Member	$\frac{BM}{d} = H$
D'	G^1H^1	$\frac{1400}{24.4} = 57.4$	G^1F^1	$\frac{900}{22.4} = 40.2$
E	JH^1	$\frac{1410}{25} = 56.4$	H^1G^1	$\frac{1050}{24.4} = 43.0$
D	JH	$\frac{1080}{24.4} = 44.2$	JH^1	$\frac{870}{25} = 34.8$

The stress in the centre vertical is got by resolving vertically at J , and the stress in it is the vertical component of stress in counterbrace JD *minus* the sum of the vertical components of stress in JH and JH^1 .

The stress in the first vertical F^1B^1 is tensile, and is approximately half the weight of the greatest number of wheel loads that can be got on $A^1C^1 = \frac{1}{2} \times 5 \times 8 = 20$ tons tension.

Table of maximum compressive stresses in verticals. (Fig. 56.)

For horizontal components see the two previous tables. The vertical components are got by multiplying the horizontal components by the tangent of the angle of inclination of the member.

Member	Horizontal Component	Vertical Component	Member	Horizontal Component	Vertical Component	Member	Horizontal Component	Vertical Component
G^1H^1	57.4	+ 6.1	H^1J	56.4	+ 2.3	JD	9.4	+14.5
G^1D^1	17.2	+24.0	H^1E	13.4	+20.0	JH	44.2	- 1.8
G^1F^1	40.2	- 8.4	H^1G^1	43.0	- 5.3	JH^1	34.8	- 1.4
Max. stress in G^1C^1		+21.7 tons	Max. stress in H^1D^1		+17.0 tons	Max. stress in JE		+11.3 tons

44. Wind load.

One specification as applied to girders is :

Wind load to be calculated at the rate of $1\frac{1}{2}$ ton per 100 square feet of surface exposed, reckoned as follows:—

I. A train surface 12 feet 6 inches high multiplied by the length of the girder.

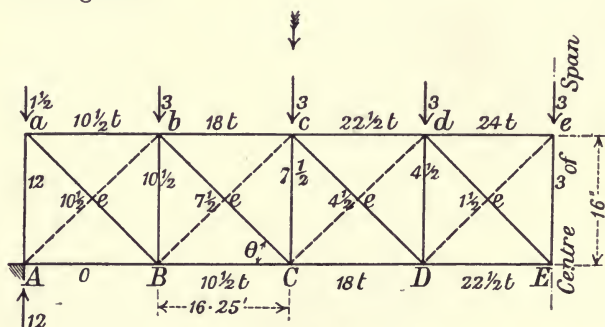

Fig. 60.

II. Surface of structure seen in elevation below rail level, and more than 12 feet 6 inches above rail.

III. For triangulated girders II. is to be doubled to provide for wind pressure on leeward girder.

Wind load to be treated as dead load.

In the present example the surface exposed may be taken at 2,600 square feet, which gives a wind load on the girder of 40 tons, say, 24 tons on the lower chord, 16 tons on the upper chord. The wind bracing is shown in plan in Fig. 60. The girders are assumed 16 feet apart centre to centre. The stresses in the chords and bracing are calculated as for an *N* or Pratt truss. There are cross diagonal braces as the wind may blow on either girder. One set of braces only being in action at a time.

Fig. 60 shows plan of bracing for lower chord. The stresses obtained from the shearing force in panel lengths are written on the diagram. Since $\theta = 45^\circ$ nearly,

$$t = \cot \theta = 1,$$

$$e = \operatorname{cosec} \theta = 1.414.$$

Wind load. Lower system of bracing. Stresses.

Chords		Braces		Cross Struts	
Member	Stress Tons	Member	Stress Tons	Member	Stress Tons
<i>ab, BC</i>	10.5	<i>Ba</i>	14.8	<i>Aa</i>	12
<i>bc, CD</i>	18	<i>Cb</i>	9.8	<i>Bb</i>	10.5
<i>cd, DE</i>	22.5	<i>De</i>	6.4	<i>Cc</i>	7.5
<i>de</i>	24	<i>Ed</i>	2.1	<i>Dd</i>	4.5
..	<i>Ee</i>	3

Wind load. Upper system of bracing. Stresses.

The load on upper system being $\frac{2}{3}$ of the load on lower system the stresses will be $\frac{2}{3}$ of the above stresses.

Chords		Braces		Cross Struts	
Member	Stress Tons	Member	Stress Tons	Member	Stress Tons
<i>AF</i>	7	<i>Ff</i>	7
<i>FG</i>	12	<i>Fg</i>	6.6	<i>Hh</i>	5
<i>GH</i>	15	<i>Gh</i>	4.2	<i>Gg</i>	3
<i>HJ</i>	16	<i>Hj</i>	1.4	<i>Jj</i>	2

The general calculation of wind stresses is more fully treated in the next chapter.

45. Total stresses.

In the tables of total stresses, which is used for the design of the different members, the live load stresses are in each case multiplied by 2, in order to allow for the sudden application of the load.

The dead load stresses are got from tables on pages 102 and 103, and the live load stresses from tables on pages 107 to 110.

For diagram of girder see Fig. 56, page 102.

Lower chord. Tension.

Member	<i>AC</i>	<i>CD</i>	<i>DE</i>
	Tons	Tons	Tons
Live load stress $\times 2$.	105	134	152
Dead load stress . .	39	57	65
Wind load stress . .	10.5	18	22.5
Total stress	154.5	209	239.5

Upper chord. Compression.

Member	<i>AF</i>	<i>FG</i>	<i>GH</i>	<i>HJ</i>
	Tons	Tons	Tons	Tons
Live load stress $\times 2$.	160	150	159.2	161.2
Dead load stress . .	56	58	66	68.2
Wind load stress . .	7	12	15	16
Total stress	223	220	240.2	245.4

Bracing and counterbracing. Tension.

Member	<i>FC</i>	<i>GD</i>	<i>HE</i>	<i>JD</i>	<i>HC</i>
	Tons	Tons	Tons	Tons	Tons
Live load stress $\times 2$.	60	53	41.6	35.2	22
Dead load stress . .	27.5	12.6	5.4
Total stress	87.5	65.6	47.0	35.2	22

Verticals (+ sign compression, - sign tension).

Member	FB	GC	HD	JE
Live load stress × 2	Tons - 40	Tons + 43.4	Tons + 34	Tons + 22.6
Dead load stress	- 9.34	+ 11.72	+ 1.7	- 0.34
Total stress	- 49.34	+ 55.12	+ 35.7	+ 22.26

46. Design of members.

UPPER CHORD. Compression.

Having drawn an approximate section (Fig. 61) it was found from Rankine's formula for columns :

$$\text{Total stress} = \text{load} = \frac{fA}{1 + a \frac{l^2}{k^2}}$$

that the working intensity of stress = 5.7 tons per square inch.

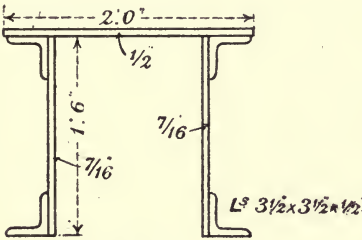

Fig. 61.

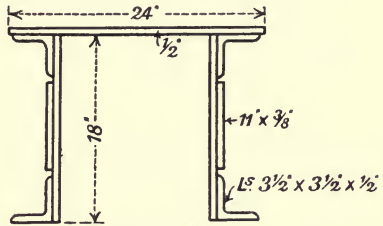

Fig. 62.

Member FG (Fig. 61).

Total stress = 220 tons.

$$\text{Area} = \frac{220}{5.7} = 38.6 \text{ square inches.}$$

Add 6 3/4-inch rivet holes in 1/2-inch plates and angles = 2.25 " "

Area required = 40.85 " "

Area provided—

1 top plate, 24" × 1/2" = 12 square inches.

2 side plates, 18" × 7/16" = 15.75 " "

4 angles, 3 1/2" × 3 1/2" × 1/2" = 13.00 " "

Total area provided = 40.75 " "

Members *GH* and *HJ* (Fig. 62).

One section will suit for these two members as the stresses are so nearly equal. Take *HJ*, which bears the greater stress.

Total stress = 245.4 tons.

$$\text{Area} = \frac{245.4}{5.7} = 43 \text{ square inches.}$$

Add rivets as in *FG* = 2.25 ,, ,,

Area required 45.25 ,, ,,

Area provided—

1 top plate, 24" × ½" = 12 square inches.

2 side plates, 18" × 7/16" = 15.75 ,, ,,

4 angles, 3½" × 3½" × ½" = 13.00 ,, ,,

2 outside side plates between

angles, 10½" × 3/8" = 8.00 ,, ,,

Total area provided = 48.75 ,, ,,

The general cross section is preserved throughout, the increased area required being got by the addition of outside plates between

the angles ; in this way the centre of gravity of the section is not altered and a constant distance is preserved between the side plates. This leads to simplicity in the design of verticals which are fixed between the side plates. If a greater sectional area were required, vertical side plates should be added inside of the full depth of the cross section.

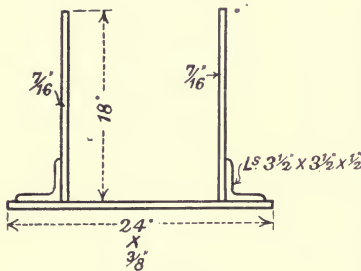

Fig. 63.

Plates should not be used of less thickness than 3/8 inch.

LOWER CHORD. Tension : Working stress 8 tons per square inch.

The section of lower chord must be similar to that of the upper chord ; the distance between the side plates in each case being the same so as to allow the verticals to fit between them.

Members *AC*, *CD*, *DE*.

The stress in *DE* is 239.5 tons. The cross section is shown in Fig. 63.

Total stress..... = 239.5 tons.

$$\text{Area} = \frac{239.5}{8} = 29.9 \text{ square inches.}$$

Add for rivet holes = 2.2 ,, ,,

Area required .. = 31.15 ,, ,,

Area provided—

1 bottom plate, $24'' \times \frac{3}{8}''$	= 9	square inches.
2 side plates, $18'' \times \frac{7}{16}''$	= 15.75	,, ,,
2 angles, $3\frac{1}{2}'' \times 3\frac{1}{2}'' \times \frac{1}{2}''$	= 6.50	,, ,,
Total area provided	= <u>31.25</u>	,, ,,

This section is the least that can be adopted for similarity of the upper and lower chords, and as the stresses in *AC* and *CD* are less than in *DE* it can be adopted throughout.

As stated before, if a larger cross section were required it should be got by the addition of side plates.

BRACES AND COUNTERBRACES. Tension.

Member	Stress <i>S</i>	Area = $\frac{S}{8}$	Add for Rivets	Area Required	Details
<i>FC</i>	87.5	10.9	1	11.9	2 plates $12'' \times \frac{1}{2}''$
<i>GD</i>	65.6	8.2	1	9.2	2 plates $12'' \times \frac{7}{16}''$
<i>HE</i>	47.0	6.0	1	7.0	2 plates $10'' \times \frac{3}{8}''$
<i>JD</i>	35.2	4.4	1	5.4	2 plates $8'' \times \frac{3}{8}''$
<i>HC</i>	22.0	2.8	1	3.8	2 plates $7'' \times \frac{3}{8}''$

The braces are riveted on to gusset plates, which are riveted inside the side plates of upper and lower chords (Fig. 65).

VERTICALS. Compression.

The section of verticals is of the form shown in Fig. 64 formed of one plate $14'' \times \frac{3}{8}''$ and 4 angle irons.

The width of the vertical must be the clear width between the gusset plates attached to the side plates of top and bottom chords. Thus :—

Width of top or bottom plate of chords	24 inches
Less 2 angles $3\frac{1}{2}'' + \frac{1}{2}''$ clearance at edge of plate	8 inches
2 side plates, each $\frac{7}{16}''$	$\frac{7}{8}$ inch
2 gusset plates, each $\frac{1}{2}''$	1 inch
Clearance for vertical to go in easily ..	$\frac{1}{8}$ inch
	<u>10 inches</u>
Total width of verticals =	14 inches

Vertical *GC*. Assume section as in Fig. 64. Apply Rankine's formula to get the area.

$$\begin{aligned} \text{Area required} &= \frac{\text{max. load}}{6} \left(1 + a \frac{l^2}{k^2}\right) \\ &= \frac{55 \cdot 12}{6} \left(1 + \frac{22 \cdot 4 \times 22 \cdot 4 \times 144}{30,000 \times 2 \cdot 1}\right) \\ &= 20 \text{ square inches app.} \end{aligned}$$

Area provided (Fig. 64) = 20.25 square inches.

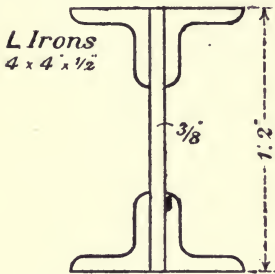

Fig. 64.

Verticals HD and JE.

If Rankine's formula be applied in the same manner it will be found that the following section gives ample area :—

- One plate 14" × $\frac{3}{8}$ ";
- 4 angle irons 4" × 3" × $\frac{3}{8}$ ".

Vertical FB is in *tension*, the stress in it being 49.34 tons, but since for practical construction it is advisable to keep all the verticals of the same form of section, this vertical may be formed

of one centre plate 14" × $\frac{3}{8}$ " and 4 angle irons 4" × 3" × $\frac{3}{8}$ ", the same as *HD* and *JE*, which is more than sufficient area, but gives uniformity of design.

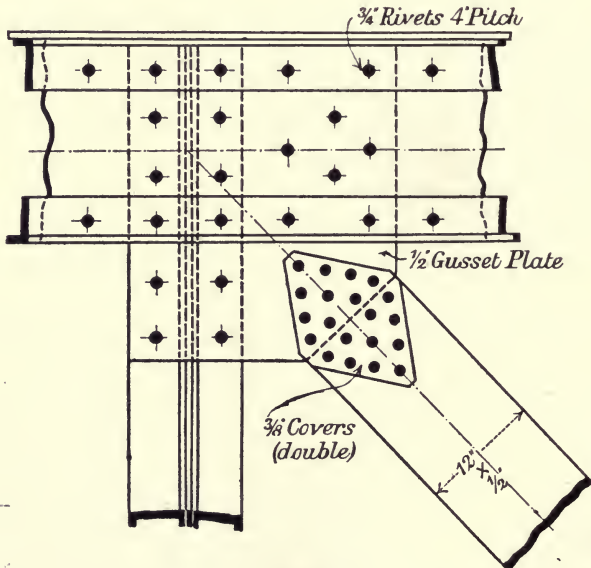

Fig. 65.

Connexion of brace and vertical to chord.

Fig. 65 shows the general arrangement of the connexion of one plate of brace and vertical to gusset plate and side plate of upper chord.

End sloping member FA.

This member is in compression. The most convenient design is to make it of such a section as to fit in between the vertical side plates of the upper and lower chords, as the verticals do.

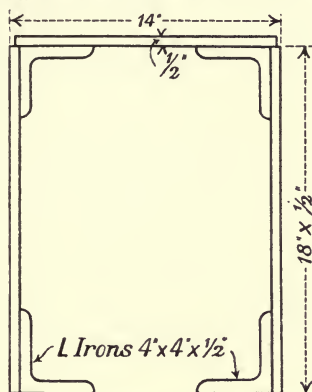

Fig. 66.

Fig. 66 shows a suitable cross section, the area of which has been got by the application of Rankine's formula :

Total stress = 223 tons ; least $k^2 = 39$; $l = 24.85$ feet.

Area = 40 square inches.

If more area is required, thicker side plates might be used, or two additional side plates might be placed between angle irons.

CHAPTER VIII.

WIND PRESSURE. PORTAL BRACING. HIGH STEEL TRESTLES.

47. Wind pressure. Lateral bracing.

The wind force on a bridge is provided for by means of an upper lateral system of bracing, attached to the upper chords of the vertical girders, and a lower lateral system attached to the lower chords. Thus, in the case of girders with horizontal chords, the lateral or wind girders are horizontal, and the chords of the main vertical girders form the chords of the lateral girders. The depth of the horizontal wind girders is equal to the distance apart of the vertical girders.

Since the lateral girders have the same chords as the vertical girders, in order to determine the resultant stresses in the latter we must add the wind stresses to the dead and live load stresses.

The form of the lateral bracing is usually of the same form as the vertical girders, either of the Pratt or Warren type, as the case may be.

Arrangement of bracing.

The wind loads are assumed horizontal, equally distributed at the panel points. As the wind pressure may act in either direction on a bridge, the stresses in the lateral or horizontal system of bracing may be reversed.

Fig. 67 shows the plan of horizontal bracing for a bridge of 4 panels. If the wind blows in the direction of the arrows, the inclined braces shown in full lines will be in tension; but if the wind loads are reversed, then these same braces will be in compression. In order to avoid this reversal of stress the panels are

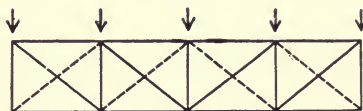

Fig. 67.

counterbraced, a second diagonal as shown in dotted lines being introduced in each panel length. When the wind acts in the direction of arrows, the inclined braces in full lines are in tension,

those shown dotted being unstressed. When the wind pressure is reversed then the dotted diagonal braces are tension and the full line diagonals are unstressed. Hence the diagonals are subject to tension only.

48. Methods of estimating wind pressure.

In practice the estimate of wind pressure to be allowed for in the design of a bridge varies a good deal. In America the general practice seems to be to assume a pressure of about 50 lbs. per square foot of exposed surface for the unloaded bridge; but with a train on the bridge a pressure of 30 lbs. per square foot on the exposed area of bridge and train, the wind load on train being treated as a moving load.

The exposed area in the case of triangulated girders is twice the area of the surface of girder as seen in elevation, so as to provide for wind pressure on the leeward girder.

The train surface is taken 10 feet high, the top of it being assumed 12 feet 6 inches and the bottom 2 feet 6 inches above rail level.

Thus, as a preliminary calculation, with a train on the bridge, taking 10 square feet per foot run as the area of truss exposed, and 10 square feet as the area of train surfaces per foot run, we get:

(a) A dead load of $30 \times 10 = 300$ lbs. per foot run of bridge.

(b) A live load of $30 \times 10 = 300$ " " " "

If (a) is assumed as equally distributed between upper and lower horizontal systems, we have

On the lateral system of upper chord

A dead load of 150 lbs. per foot run of girder,

On the lateral system of lower chord

A dead load of 150 lbs. per foot run of girder

plus a live load of 300 lbs. per foot run of girder.

The wind loads on the horizontal system of upper or unloaded chord may be taken as equally distributed on the windward and leeward sides, or as acting entirely on the windward side. For the loaded chord they are taken wholly on the windward side.

Government of India.

The Government of India rules are:—

For bridge unloaded.—A wind pressure of 56 lbs. per square foot on the full surface of both girders.

For bridge loaded.—A wind pressure of 34 lbs. per square foot on (a) the train surface taken 10 feet high—that is, from 2 feet to 12 feet above rail level, and (b) on the surface of both girders outside the train.

This is taken as a static load.

Wind load is not taken into consideration in areas of main members unless it exceeds 25 per cent. of the dead, live and impact.

49. Portal bracing.

The object of the portal bracing is to transmit the reactions of the upper wind bracing to the abutments and to stiffen the end posts against vibrations. In calculating the stresses in portal bracing and end posts, the latter are assumed to be fixed at their lower ends, the connexions of the end cross girder being made sufficiently rigid to secure this result.

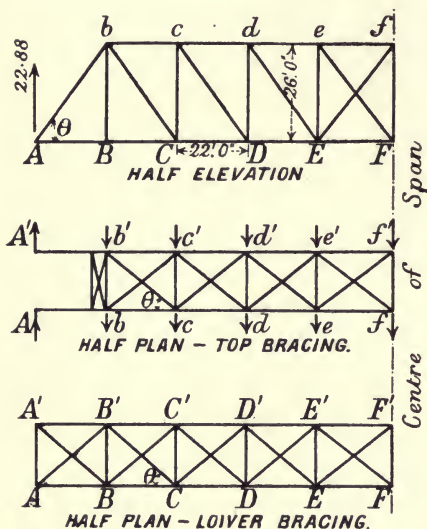

Fig. 68.

girders. The stresses in the members of portal bracing are quickly found by the method of sections.

A much fuller treatment of this subject is to be found in 'Modern Framed Structures,' by Johnson, Turnlaure, and Bryan, which I have consulted.

EXAMPLES.

1. A lattice bridge of the Pratt type, as shown in half elevation in Fig. 68, span 220 feet, is divided into ten equal bays of 22 feet each. Depth 26 feet, centre to centre of chords. Width between girders 16 feet.

The half plans of wind bracing for upper and lower chords are shown in Fig. 68, and, as explained before, only one diagonal brace is stressed.

Length of each diagonal brace and end post

$$= \sqrt{22^2 + 26^2} = 34 \text{ feet.}$$

UPPER WIND BRACING. DEAD PANEL LOAD.

Loading.—For the upper wind bracing the bridge is taken as unloaded—that is, no train on the bridge, and the wind load on this upper system is taken as

$\frac{1}{2}$ {Twice the area of elevation of one girder} at 50 lbs. per sq. ft.

Approximately, the area of exposed surface in elevation of one girder = 1,560 square feet.

Hence, total wind pressure per foot run of bridge

$$= \frac{3120 \times 50}{220 \times 2240} = 0.32 \text{ ton.}$$

Wind pressure per foot run of *upper* chord = $\frac{0.32}{2} = 0.16 \text{ ton.}$

Therefore, panel wind load for *upper* chord

$$= 0.16 \times 22 = 3.52 \text{ tons} \dots\dots\dots(1).$$

OVERTURNING MOMENT FOR BRIDGE.

Reactions.—*Corresponding stresses in end posts and chords.*

(a) The overturning moment of these wind forces about lower chord is

$$8 \times 3.52 \times 26 = 732.16 \text{ feet tons,}$$

which must be balanced by a reaction couple at *each* end of the span. The value of each of these abutment wind reactions is therefore

$$\frac{732.16}{2 \times 16} = 22.88 \text{ tons,}$$

acting upwards on the leeward girder and downwards on the windward girder. Thus, as in elevation of girder (Fig. 68) the reaction at the ends of the leeward girder is increased by 22.88 tons, and the corresponding compressive stress in the inclined post is

$$22.88 \operatorname{cosec} \theta = \frac{22.88 \times 34}{26} = 30 \text{ tons.}$$

Corresponding tensile stress in lower chord is

$$22.88 \cot \theta = 19.4 \text{ tons.}$$

The compressive stress in upper chord is also 19.4 tons. These stresses are uniform throughout the chords, as, excepting the end inclined post, there is no stress in the diagonals.

(b) *Stresses due to wind load on train. Live load.*

Assuming the train surface exposed as 10 square feet per foot run and the wind pressure as 34 lbs. per square foot, then the wind load on train is 340 lbs. per lineal foot. Assume this load to act at a height of 11 feet above the plane of lower wind bracing.

Therefore wind load for one panel length

$$= \frac{340 \times 22}{2240} = 3.34 \text{ tons} \dots\dots\dots(2)$$

and reaction at leeward end of cross girder is

$$\frac{3.34 \times 11}{16} = 2.3 \text{ tons.}$$

Hence the effect of the overturning action of wind on train is to produce a load of 2.3 tons per panel of lower chord downward on the leeward girder, and the stresses are obtained as for a live load of 2.3 tons per panel. For the windward girder the stresses are of the same value as for the leeward girder, with reversed sign.

DEAD WIND LOAD ON LOWER CHORD BRACING.

In addition to the live load due to wind on the moving train, there is a dead wind load which may be taken at 34 lbs. per square foot over an exposed area of about 6½ square feet per lineal foot of girder

$$= 6\frac{1}{2} \times 34 = 221 \text{ lbs.} = \frac{1}{10} \text{ ton per lineal foot.}$$

That is, a dead panel load of $= \frac{2.2}{10} = 2.2$ tons per lineal foot (3).

Wind Bracing. Stresses (Fig. 68).

The top lateral system is a horizontal Pratt girder of 8 panels supported at the ends by the portal struts. The dead wind load carried at each upper panel point is 3.52 tons, Equation (1). The lower lateral system consists of a horizontal Pratt girder of 10 panels, for which the panel dead load is 2.2 tons, and the panel live load is 3.34 tons, Equations (3) and (2).

The length of diagonals $= \sqrt{22^2 + 16^2} = 27.2$ feet.

$$\text{cosec } \theta = \frac{27.2}{16} = 1.7.$$

If F is the shear in any panel length, the stress in diagonal in that panel

$$= F \text{ cosec } \theta.$$

Top Lateral Stresses—Tensile.

Member	Shear	Stress
	Tons	Tons
b^1c	$3\frac{1}{2} \times 3.52 = 12.3$	$12.3 \times 1.7 = 21$
c^1d	$2\frac{1}{2} \times 3.52 = 8.8$	$8.8 \times 1.7 = 15$
d^1e	$1\frac{1}{2} \times 3.52 = 5.3$	$5.3 \times 1.7 = 9$
e^1f	$\frac{1}{2} \times 3.52 = 1.8$	$1.8 \times 1.7 = 3$

In determining the section of the braces the area required may be small; but as the braces are long and require stiffness angles should be used. In this case all the diagonal braces might be angle bars $6'' \times 3\frac{1}{2}'' \times \frac{3}{8}''$.

Lower Lateral Stresses—Tensile.

Member	Dead Load		Live Load	
	Shear	Stress	Shear	Stress
	Tons		Tons	
A'B	$4\frac{1}{2} \times 2.2 = 9.9$	$9.9 \times 1.7 = 16.8$	$3.34 \times \frac{45}{10} = 15.0$	$15 \times 1.7 = 25.5$
B'C	$3\frac{1}{2} \times 2.2 = 7.7$	$7.7 \times 1.7 = 13$	$3.34 \times \frac{36}{10} = 12.0$	$12 \times 1.7 = 20.4$
C'D	$2\frac{1}{2} \times 2.2 = 5.5$	$5.5 \times 1.7 = 9.4$	$3.34 \times \frac{28}{10} = 9.4$	$9.4 \times 1.7 = 16.0$
D'E	$1\frac{1}{2} \times 2.2 = 3.3$	$3.3 \times 1.7 = 5.6$	$3.34 \times \frac{21}{10} = 7.0$	$7 \times 1.7 = 12.0$
E'F	$\frac{1}{2} \times 2.2 = 1.1$	$1.1 \times 1.7 = 1.9$	$3.34 \times \frac{12}{10} = 5.0$	$5 \times 1.7 = 8.5$

The total stress in lower lateral system is the dead load stress plus live load stress plus impact allowance.

Chord stresses due to wind.

The chord stresses due to wind loads are got by adding the components of the stresses in diagonal braces along the chords, as previously explained in the chapter on girders with parallel chords.

The resultant stresses in the chord members of the main vertical girders are then obtained by combining the stresses due to dead load, live load, wind load on girder, wind load on train, and the overturning effect of wind on bridge and train.

Design of portal bracing.

The outline of a design for portal bracing is shown in Fig. 69.

The inclined length of the end posts is 34 feet. The vertical depth of this bracing, in order to allow a clear headroom of 15 feet above rail level, is 8 feet, which gives a depth in the plane of the inclined end posts of 10 feet 6 inches. The wind load on top laterals at each panel point =

3.52 tons. The wind force on one side of portal bracing at top is

equal to the reaction due to all the wind loads—that is,

$$= 4 \times 3.52 = 14.08 \text{ tons.}$$

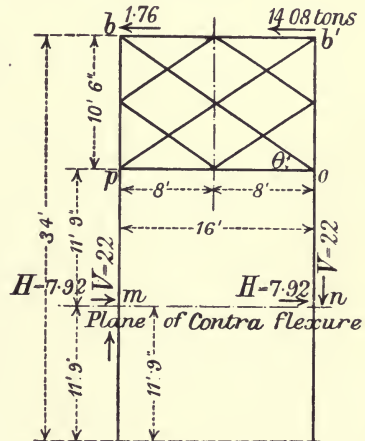

Fig. 69.

On the other side of portal bracing at top there is half a panel load

$$= \frac{3.52}{2} = 1.76 \text{ ton.}$$

It is assumed that the end posts are *fixed* at their lower ends by the end cross girder connexions; also that the plane of contraflexure *mn* is midway between the bottom of portal bracing and the foot of the end posts. Thus *m* and *n* are points in inflection.

The reactions *H* and *V* may be considered as applied at the points of inflection *m* and *n*, at which points the bending moment is zero.

The horizontal reactions at *m* and *n* are generally assumed equal.

$$\text{Hence } H = \frac{14.08 + 1.76}{2} = 7.92 \text{ tons.}$$

The vertical reactions are got by taking moments about *m* or *n*.

$$V = \frac{15.84 \times 22\frac{1}{4}}{16} = 22 \text{ tons.}$$

Stress in top horizontal strut, b¹b.

Taking moments about point *o* in lower strut,

$$\begin{aligned} \text{Stress} &= \frac{14.08 \times 10.5 + 7.92 \times 11.75}{10.5} \\ &= 14.08 + \frac{7.92 \times 11.75}{10.5} \\ &= 14.08 + 8.8 \\ &= 22.9 \text{ tons compressive.} \end{aligned}$$

Stress in lower horizontal strut, op.

Taking moments about *b¹*.

$$\begin{aligned} \text{Stress} &= \frac{7.92 \times 22.25}{10.5} \\ &= 16.8 \text{ tons compressive.} \end{aligned}$$

Stress in diagonals

$$\begin{aligned} &= \frac{V}{4} \operatorname{cosec} \theta = \frac{22}{4} \times 1.8 \\ &= 9.9 \text{ tons.} \end{aligned}$$

End posts.

The maximum bending moment in the end posts

$$\begin{aligned} &= H \times 11.75 \\ &= 7.92 \times 11.75 \\ &= 93.06 \text{ feet tons.} \end{aligned}$$

The compression in mp is 22 tons = V .

The tension in no is 22 tons = V .

There is no direct stress in pb and ob^1 .

The area of the end post must be designed to resist the combined compressive stress due to the maximum bending moment *plus* the direct stress V *plus* the stresses due to dead and live loads.

2. Portal bracing.

Where the headroom above rail level is restricted a very common form of portal bracing is shown in Fig. 70.

Let the inclined length of the end post be 34 feet and the depth of the portal bracing at junction with end posts be 8 feet, the width between end posts being 16 feet.

Take, as in last example, a wind force of 14.08 tons at hip b .

The plane of contraflexure is assumed half way between the foot of posts and bottom of the portal bracing fixing at o .

As before, assuming the horizontal components H as equal, we have

$$2H = 14.08.$$

$$\therefore H = 7.04 \text{ tons.}$$

To get V , take moments about m or n .

$$\therefore V = \frac{14.08 \times 21}{16} = 18.48 \text{ tons.}$$

Stress in ot

$$\begin{aligned} &= V \operatorname{cosec} \theta = 18.48 \operatorname{cosec} 45^\circ \\ &= 18.48 \times 1.414 = 26.1 \text{ tons tension.} \end{aligned}$$

Stress in pt

$$= 26.1 \text{ tons compression.}$$

Stress in sr . Moments about t .

$$\text{Stress in } sr = \frac{7.04 \times 21 - 18.48 \times 8}{4} = 0.$$

Therefore, also, stress in rb and $sb^1 = 0$.

Stress in bt . Moments about o .

$$\text{Stress in } bt = \frac{14.08 \times 8 + 7.04 \times 13}{8}$$

$$= 14.08 + \frac{7.04 \times 13}{8}$$

$$= 25.52 \text{ tons compression.}$$

Stress in $b't$

$$= \frac{7.04 \times 13}{8} = 11.44 \text{ tons tension.}$$

Maximum bending moments in the end post

$$= 7.04 \times 13 = 91.52 \text{ foot tons.}$$

The direct compression in $mp = V = 18.48$ tons.

The direct tension in $no = \bar{V} = 18.48$ tons.

The members bb^1 , pt , and ot might each be formed of two angle bars $6'' \times 3\frac{1}{2}'' \times \frac{3}{8}''$, spaced $\frac{1}{2}$ inch apart.

The other members, br , rs , and sb^1 might be formed of two angle bars $3\frac{1}{2}'' \times 3\frac{1}{2}'' \times \frac{3}{8}''$.

Connexions made by $\frac{1}{2}$ -inch gusset plates.

Sway bracing.

The bracing between verticals of main girders may be lighter than the portal bracing. Fig. 71 shows two simple forms, in which the top and bottom horizontal members may be of some such section as

2 angles $4'' \times 3'' \times \frac{3}{8}''$ separated by a $\frac{3}{8}$ -plate 1 foot to 9 inches deep,

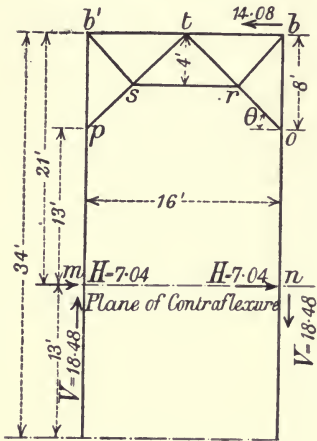

Fig. 70.

the diagonal braces being Tee bars or angle bars $6'' \times 3'' \times \frac{3}{8}''$, riveted to the top and bottom $\frac{3}{8}''$ plates.

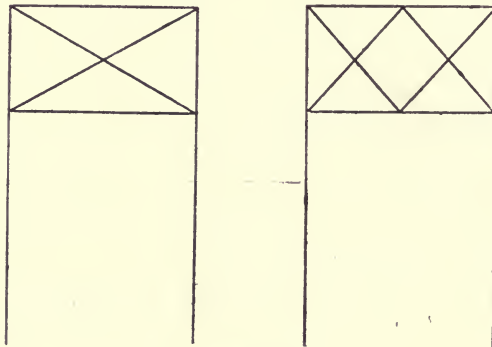

Fig. 71.

50. Steel trestles.

Steel trestles are now greatly used as piers for bridging over deep valleys. The general type of such a bridge is shown in elevation in Fig. 72, and a transverse section showing one trestle is given in Fig. 74. The girders are usually plate girders. The

trestles are braced together longitudinally in pairs so as to form towers. The tower spans are usually 30 or 40 feet, and the intermediate spans 60 feet. The length of the intermediate spans depends partly on the height of pier, but chiefly on the weight that can be conveniently dealt with in erection by overhanging. For a single line of rails the towers consist of four columns, braced longitudinally and transversely; the longitudinal bracing is required to resist the longitudinal force parallel to the rails, due to the sudden application of the brakes to a moving train; the transverse bracing is to resist wind pressure. In order to increase the lateral stability of the trestles against overturning the columns are built to a batter of about 1 to 6—that is, 1 horizontal to 6 vertical. The amount of batter necessary is determined from the condition that the trestles should not require to be anchored, so as to secure them against overturning—that

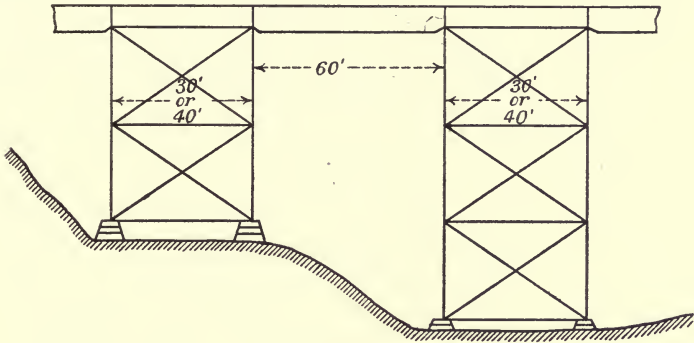

Fig. 72.

is, there should be no tension at the base of the windward column. If the bridge is on a curve, the centrifugal force should be taken into account. The determination of the stresses in a high bridge trestle will best be explained by an example.

Example.

Let a railway viaduct consist of a series of plate girders, the length of the tower spans being 40 feet, and the length of the intermediate spans between towers 50 feet. Height of trestles 72 feet, divided up by bracing into 3 tiers or sections each 24 feet high. Batter of columns transversely 1 in 6. Width at top, 10 feet. Width at base, 34 feet. Depth of girders, 5 feet.

Fig. 73 shows longitudinal elevation of one 40-foot tower span. Fig. 74 gives a transverse elevation showing one trestle.

The stresses in the members are to be calculated for the following loads: Dead load, live load, wind pressure on girder,

train, and towers, and the longitudinal force due to the sudden retardation of moving train.

DEAD LOAD STRESSES.

Weight *per foot run* of 50 feet span = 660 lbs. (girders) + 540 lbs. (floor and permanent way)
= 1200 lbs.

Weight *per foot run* of 40 feet span = 600 lbs. (girders) + 540 lbs. (floor and permanent way)
= 1140 lbs.

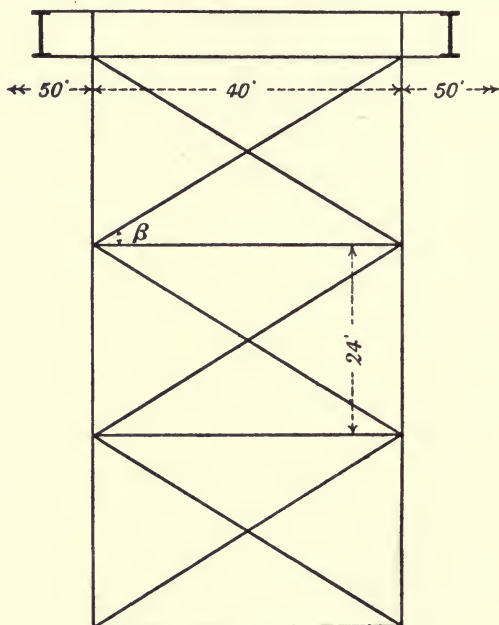

Fig. 73.

The weight of one tower with longitudinal and transverse bracing may be assumed as about 48 tons.

The dead load at top of *each* column due to girders

= the sum of the reactions of the 40 feet and 50 feet girders

$$= \frac{570 \times 20 + 600 \times 25}{2240}$$

= 12 tons.

The dead load due to weight of one 24 feet length of column at each apex

$$= \frac{48}{4 \times 3} = 4 \text{ tons.}$$

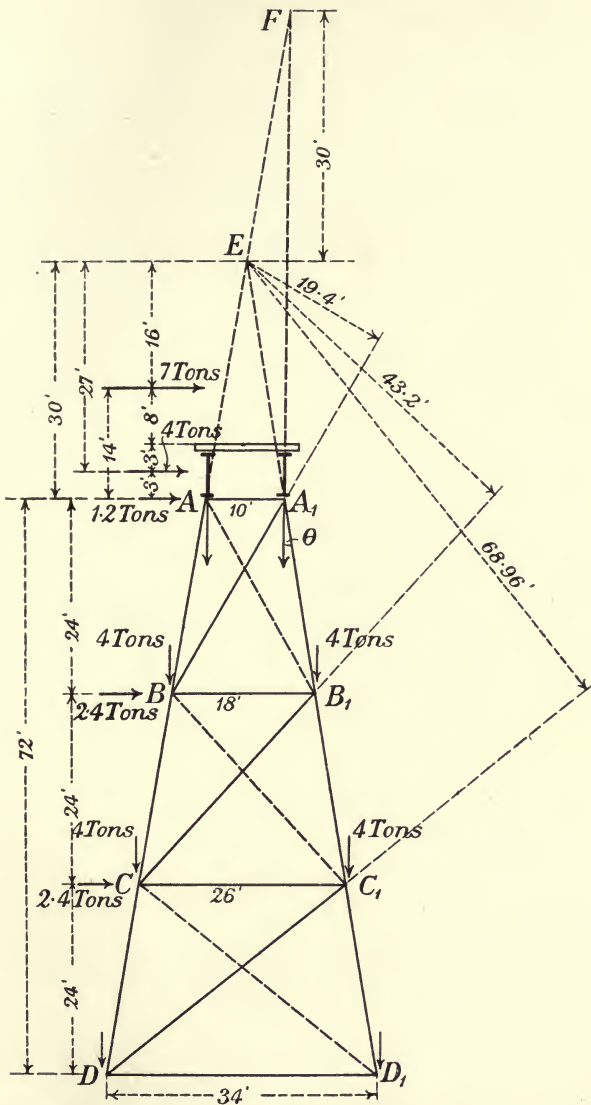

Fig. 74.

Let θ = inclination of the column to vertical.
 Vertical height of one length of column = 24 feet.
 Inclined length of column = $\sqrt{24^2 + 4^2} = 24.33$ feet.

$$\sec \theta = \frac{24.33}{24} = 1.0137.$$

$$\tan \theta = \frac{1}{6}.$$

Dead load stresses. + sign denotes compression, - sign denotes tension.

$$AB = A_1B_1 = +12 \sec \theta = +12 \times 1.0137 = +12.17 \text{ tons.}$$

$$BC = B_1C_1 = +(12+4) \times 1.0137 = +16.2 \text{ tons.}$$

$$CD = C_1D_1 = +(12+8) \times 1.0137 = +20.3 \text{ tons.}$$

$$AA_1 = +12 \tan \theta = +\frac{12}{6} = +2 \text{ tons.}$$

$$BB_1 = +\frac{16}{6} = +2.7 \text{ tons.}$$

$$CC_1 = +\frac{20}{6} = +3.3 \text{ tons.}$$

There is no stress in diagonal members due to the symmetrical vertical loads.

LIVE LOAD STRESSES.

The live load due to the weight of the heaviest train load which can be concentrated on the spans may be taken as 50 tons at the top of each column.

Live load stress in column

$$\begin{aligned} &= +50 \sec \theta = +50 \times 1.014 \\ &= +50.7 \text{ tons.} \end{aligned}$$

Live load stress in top transverse strut AA_1

$$\begin{aligned} &= 50 \tan \theta = \frac{50}{6} \\ &= +8.34 \text{ tons.} \end{aligned}$$

The stress in diagonal transverse braces is zero, as in the case of dead load.

LONGITUDINAL FORCE DUE TO THE SUDDEN APPLICATION OF BRAKES TO MOVING TRAIN.

Stresses.

The longitudinal horizontal force acting at the top of the tower is

The maximum weight due to train on trestle \times coefficient of friction

$$= 50 \times \frac{1}{5} = 10 \text{ tons}$$

assuming the coefficient of friction as $\frac{1}{5}$.

The longitudinal diagonal bracing must be designed to resist this force.

To determine the stresses in columns and diagonals of longitudinal bracing the following data are necessary :—

Distance apart longitudinally at tower trestles = 40 feet.

Inclined length of one section of column = 24·33 feet.

Length of diagonal = $\sqrt{24\cdot33^2 + 40^2} = 46\cdot8$ feet.

If β = inclination to horizontal of diagonals,

Stress in longitudinal diagonals of tower

$$= -10 \times \sec \beta.$$

$$= -10 \times \frac{46\cdot8}{40}$$

$$= -11\cdot7 \text{ tons.}$$

Stress in columns.

$$AB = A_1B_1 = 10 \tan \beta = 10 \times \frac{24\cdot33}{40} = 6\cdot08 \text{ tons.}$$

$$BC = B_1C_1 = 2 \times 6\cdot08 = 12\cdot16 \text{ tons.}$$

$$CD = C_1D_1 = 3 \times 6\cdot08 = 18\cdot24 \text{ tons.}$$

WIND STRESSES.

There are two cases to consider (a) when the structure is loaded with train and (b) when the structure is unloaded.

Case (a).—The surface of the train exposed to the wind is assumed as 10 square feet per lineal foot, and the depth of girder and floor is taken as 6 feet.

The wind pressure is taken as 34 lbs. per square foot.

Thus, we have in this case a horizontal force of 340 lbs. per lineal foot acting at a height of 8 feet above base of rail, a horizontal force of 34 lbs. per square foot on the girders and floor, and a horizontal force assumed at $\frac{1}{10}$ of a ton per foot of vertical height of columns.

Case (b).—For the structure unloaded the horizontal force of wind is taken as 50 lbs. per square foot on the girders and floor, and a horizontal force of $\frac{1}{6}$ ton per foot of vertical height of columns.

Consider Case (a) : one trestle.

Wind pressure on train acting 8 feet above base of rail

$$= \frac{34 \times 10}{2240} \times \frac{50 + 40}{2} = 7 \text{ tons.}$$

Wind pressure on girders and floor (6 feet deep) acting 3 feet above top of column

$$= \frac{34 \times 6}{2240} \times \frac{50 + 40}{2} = 4 \text{ tons.}$$

Wind pressure at top panel point of column

$$= \frac{1}{10} \times \frac{24}{2} = 1.2 \text{ ton.}$$

„ „ at first panel point below top

$$= \frac{1}{10} \times 24 = 2.4 \text{ ton.}$$

„ „ at second panel point below top

$$= \frac{1}{10} \times 24 = 2.4 \text{ tons.}$$

Wind stresses in columns.

To find the stress in any division of the column take moments about the opposite apex; thus, for the stress in AB take moments about A_1 , and for the stress in B_1C_1 take moments about C .

The lever arms are :

$$10 \cos \theta = 9.86 \text{ feet.}$$

$$18 \cos \theta = 17.75 \text{ „}$$

$$26 \cos \theta = 25.6 \text{ „}$$

$$34 \cos \theta = 33.5 \text{ „}$$

$$\text{Stress in } AB = -\frac{7 \times 14 + 4 \times 3}{9.8} = -11.15 \text{ tons.}$$

$$\text{„ } A_1B_1 = +\frac{7 \times 38 + 4 \times 27 + 1.2 \times 24}{17.75} = +22.7 \text{ tons.}$$

$$\text{„ } BC = -22.7 \text{ tons.}$$

$$\begin{aligned} \text{„ } B_1C_1 &= +\frac{7 \times 62 + 4 \times 51 + 1.2 \times 48 + 2.4 \times 24}{25.6} \\ &= +29.41 \text{ tons.} \end{aligned}$$

$$\text{„ } CD = -29.41 \text{ tons.}$$

$$\begin{aligned} \text{„ } C_1D_1 &= +\frac{7 \times 86 + 4 \times 75 + 1.2 \times 72 + 2.4 \times 48 + 2.4 \times 24}{33.5} \\ &= +34.7 \text{ tons.} \end{aligned}$$

When the wind acts from the other side the stresses would be

$$\begin{aligned} A_1B_1 &= -11.15; \quad AB = +22.7; \quad B_1C_1 = -22.7; \quad BC = +29.41; \\ C_1D_1 &= -29.41; \quad CD = +34.7. \end{aligned}$$

Stresses in horizontal struts.

For AA_1 take moments about F , the point where windward column produced meets vertical through A_1 .

$$\text{Stress in } AA_1 = +\frac{7 \times 46 + 4 \times 57 + 1.2 \times 60}{60} = +10.4 \text{ tons.}$$

For BB_1 , CC_1 , DD_1 take moments about E , the point in which the two columns produced meet.

$$\begin{aligned} \text{Stress in } BB_1 &= + \frac{7 \times 16 + 4 \times 27 + 1.2 \times 30 + 2.4 \times 54}{54} \\ &= + 7.1 \text{ tons.} \end{aligned}$$

$$\begin{aligned} \text{,, } CC_1 &= + \frac{7 \times 16 + 4 \times 27 + 1.2 \times 30 + 2.4 \times 54}{78} + 2.4 \\ &= + 7.3 \text{ tons.} \end{aligned}$$

When the wind acts from the other side the stresses in horizontal struts would be the same.

Stress in diagonals.

Take moments about E , the point in which the two columns produced meet. Fig. 74.

Let θ = angle of inclination of column to vertical.

Let θ_1 , θ_2 , θ_3 be the angles of inclination to vertical of BA_1 , CB_1 , DC_1 respectively, then $\tan \theta = \frac{1}{6}$, $\theta = 9^\circ 27'$; $\theta_1 = 30^\circ 15'$; $\theta_2 = 42^\circ 30'$; $\theta_3 = 51^\circ 20'$; $\theta_1 - \theta = 20^\circ 48'$; $\theta_2 - \theta = 33^\circ 3'$; $\theta_3 - \theta = 41^\circ 53'$.

The lever arms are found by calculation to be :

$$\text{Arm of } BA_1 = 19.4 \text{ feet.}$$

$$\text{,, } CB_1 = 43.2 \text{ ,,}$$

$$\text{,, } DC_1 = 68.96 \text{ ,,}$$

$$\text{Stress in } BA_1 = - \frac{7 \times 16 + 4 \times 27 + 1.2 \times 30}{19.4} = - 13.2 \text{ tons.}$$

$$\begin{aligned} \text{,, } CB_1 &= - \frac{7 \times 16 + 4 \times 27 + 1.2 \times 30 + 2.4 \times 54}{43.2} \\ &= - 8.9 \text{ tons.} \end{aligned}$$

$$\begin{aligned} \text{,, } DC_1 &= - \frac{7 \times 16 + 4 \times 27 + 1.2 \times 30 + 2.4 \times 54 + 2.4 \times 78}{68.96} \\ &= - 8.32 \text{ tons.} \end{aligned}$$

The stresses could also be got by equating to zero the sum of the vertical components of stress in the three inclined members of panel; thus, for the stress in CB_1 we get

$$CB_1 \cos \theta_2 + CB \cos \theta + C_1 B_1 \cos \theta = 0.$$

$$\begin{aligned} \text{Stress in } CB_1 &= -(C_1 B_1 \cos \theta + CB \cos \theta) \sec \theta_2 \\ &= -(29 - 22.4) 1.3566 \\ &= - 8.9 \text{ tons.} \end{aligned}$$

When the wind acts from the other side the dotted diagonals would be stressed, and the stresses would be

$$B_1 A = -13.2 \text{ tons; } C_1 B = -8.9 \text{ tons; } D_1 C = -8.32 \text{ tons.}$$

Overturning moment and moment of stability.

In order that there may be no tension at the foot of windward column, the moment of the vertical loads must be greater than the moment of the wind forces.

For train on:

$$\begin{aligned} \text{Moment of stability} &= (100 + 24 + 16) \frac{34}{2} \\ &= 2380 \text{ foot tons.} \end{aligned}$$

$$\begin{aligned} \text{Overturning moment about } D_1 &= 7 \times 86 + 4 \times 75 + 1 \cdot 2 \times 72 + 2 \cdot 4 \times 48 + 2 \cdot 4 \times 24 \\ &= 1161 \cdot 2 \text{ foot tons,} \end{aligned}$$

so that this condition of stability is amply ensured with train on.

With the train off:

$$\begin{aligned} \text{Moment of stability} &= 680 \text{ foot tons,} \\ \text{Overturning moment} &= 559 \text{ ,, ,,} \end{aligned}$$

and the condition of stability is still fulfilled.

The least distance apart of the columns at base can be obtained as a preliminary calculation by dividing the overturning moment of the wind by half the vertical load on trestle.

SUMMARY.

Table of Maximum Stresses.

Impact is taken as equal to the live load stress.

Columns.

Member	AB A_1B_1	BC B_1C_1	CD C_1D_1
	Tons	Tons	Tons
Dead load	+12·17	+16·2	+20·3
Live load	+50·7	+50·7	+50·7
Impact	+50·7	+50·7	+50·7
Longitudinal	+ 6·08	+12·16	+18·24
Wind	+22·7	+29·41	+34·7
Total	+142·35	+159·17	+174·64

Horizontal transverse strut, AA_1 .

$$\begin{aligned} \text{Dead load} &+ 2 \cdot 0 \text{ tons} \\ \text{Live load} &+ 8 \cdot 34 \text{ ,,} \\ \text{Impact} &+ 8 \cdot 34 \text{ ,,} \\ \text{Wind} &+ 10 \cdot 4 \text{ ,,} \\ \hline \text{Total..} &\underline{\underline{29 \cdot 08 \text{ tons}}} \end{aligned}$$

Transverse diagonals.

These diagonals are in tension due to the wind forces; the full line diagonals (Fig. 74) being in action when wind blows from the left; the dotted diagonals being stressed when wind blows from the right.

Stress in BA_1 , and $B_1A = -13.2$ tons.

„ „ CB_1 , and $C_1B = -8.9$ „

„ „ DC_1 , and $D_1C = -8.32$ „

There is no stress in these diagonals due to vertical loads, and the minimum stress in each is zero.

Longitudinal diagonal braces.

Stress in each of the longitudinal diagonal braces due to tractive force or sudden retardation of train by brakes is
 -11.7 tons.

General design of members.

Columns may be built up of angles and plates, or formed of channel irons or I beams, connected by flats or lattice bracing.

In the example the columns might consist of :

2 channels $15'' \times 4'' \times 41.9$ lbs. per foot.

2 flats $18'' \times \frac{1}{2}''$.

Area 42.7 square inches.

The *diagonals* which are in tension require rigidity.

The longitudinal diagonals are 46.8 feet long, and the longest transverse diagonal is 38.4 feet.

In section all the diagonals should consist of some such section as 4 angles $4\frac{1}{2}'' \times 3'' \times \frac{1}{2}''$, spaced $12''$ to $15''$ apart, forming a latticed box girder with lattice bracing of bars $2\frac{1}{2}'' \times \frac{1}{2}''$ on the 4 sides.

The *horizontal struts* would be of similar design.

The unit stress should be determined from the column formula, having first found the ratio of $\frac{l}{k}$.

CHAPTER IX.

CONTINUOUS GIRDERS.

51. Uniform loads.

When a girder is supported at more than two points it is said to be continuous. When loaded a portion of each span near the supports is bent convex upwards, the upper fibres being in tension, and the lower fibres in compression. The central portion of each span is bent concave upwards, the upper fibres being in compression, and the lower fibres in tension just as in a loaded girder supported at two points. At the points of contrary flexure, or points of inflection, the curvature changes sign, the bending moment is zero, and consequently the flange stresses are zero.

52. To find the bending moment at any section of a span of a continuous girder loaded with a uniform load.

Let l_1 be the length of the span 1—2 (Fig. 75).

„ w_1 be weight of the uniform load per foot run.

„ x be the abscissa of any section K referred to support 1 as origin.

„ M_1 and M_2 be the moments of the elastic forces at the supports 1 and 2 respectively.

„ M be the bending moment at K .

„ F be the shearing force at K .

„ F_1 be the shearing force on a section in span 1—2, infinitely near to and on the right of support 1.

„ F_2' the shearing force on a section in the span 1—2, infinitely near to and on the left of support 2.

Considering the separate equilibrium of the portion $(l_1 - x)$ of the span, we get

$$F_2' (l_1 - x) - M_2 - \frac{w_1 (l_1 - x)^2}{2} - M = 0,$$

or
$$M = -M_2 + F_2' (l_1 - x) - \frac{w_1 (l_1 - x)^2}{2} \dots \dots \dots (1).$$

Again, considering the whole span, we have

$$F_2' l_1 + M_1 - M_2 - \frac{w_1 l_1^2}{2} = 0,$$

or
$$F_2' = \frac{M_2 - M_1}{l_1} + \frac{w_1 l_1}{2} \dots\dots\dots (2).$$

Substituting in (1) for F_2' its value from (2),

$$\begin{aligned} M &= -M_2 + (M_2 - M_1) + \frac{w_1 l_1^2}{2} - (M_2 - M_1) \frac{x}{l_1} - \frac{w_1 l_1 x}{2} \\ &\quad - \frac{w_1}{2} (l_1^2 - 2l_1 x + x^2) \\ &= -M_1 - (M_2 - M_1) \frac{x}{l_1} + \frac{w_1 x}{2} (l_1 - x) \dots\dots\dots (3) \\ &= -M_1 - (M_2 - M_1) \frac{x}{l_1} + m \end{aligned}$$

where m is the bending moment at the section K for a span l_1 similarly loaded, but merely supported at the ends.

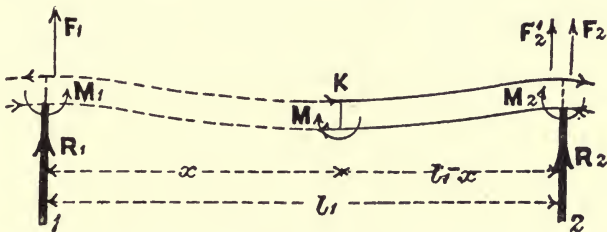

Fig. 75.

The shearing force at K is

$$F = F_2' - w_1(l_1 - x) \dots\dots\dots (4),$$

which for $x = 0$, gives by Equation (2)

$$\begin{aligned} F_1 &= F_2' - w_1 l_1 \\ &= \frac{M_2 - M_1}{l_1} - \frac{w_1 l_1}{2} \dots\dots\dots (5). \end{aligned}$$

From these equations the bending moment and shearing force at any section of the span can be found, when the moments at each extremity of the span are known.

The maximum value of M at any section intermediate between

the points of inflection occurs where the shearing force F changes sign, its position being got by solving for x in the equation

$$F = 0,$$

or by Equations (2) and (4)

$$\frac{M_2 - M_1}{l_1} + \frac{w_1 l_1}{2} - w_1 (l_1 - x) = 0;$$

hence,
$$x = \frac{l_1}{2} - \frac{1}{w_1 l_1} \{M_2 - M_1\} \dots \dots \dots (6).$$

The substitution in Equation (3) of the value of x obtained from (6) will give the *maximum bending moment occurring between the points of inflection.*

The positions of the points of inflection are got by solving for x in the equation

$$M = 0;$$

or
$$-M_1 - (M_2 - M_1) \frac{x}{l_1} + \frac{w_1 x}{2} (l_1 - x) = 0 \dots \dots \dots (7).$$

53. Graphic representation of the bending moment at any section of a given span.

Let 1 and 2 be the supports of span 1—2 (Fig. 76) of length l_1 .

Then by last article the bending moment at any section distant x from the left support 1 is :

$$\begin{aligned} M &= m - M_1 - (M_2 - M_1) \frac{x}{l_1} \\ &= m - \left\{ M_1 + (M_2 - M_1) \frac{x}{l_1} \right\} \end{aligned}$$

where m is the bending moment at the section for a span l_1 similarly loaded, *but merely supported at the ends.*

In upper diagram of Fig. 76 let 1P2 be drawn to represent the bending moment diagram supposing 1—2 a supported girder, and on the same scale draw the verticals 1A and 2B to represent the pier moments M_1 and M_2 respectively. Join AB. Then ordinates to 1P2 correspond to values of m , and ordinates to the line AB correspond to values of $M_1 + (M_2 - M_1) \frac{x}{l_1}$ in above equation.

The actual bending moment at any point in the span 1—2 as shown in lower diagram of Fig. 76, is represented by the difference of the ordinates to the curve 1P2 and the straight line AB at the same point.

In the lower diagram 1a and 2b drawn perpendicular to 1—2

represent the pier moments M_1 and M_2 at 1 and 2 respectively. The ordinate fd at abscissa x represents

$$\left\{ -M_1 + (M_2 - M_1) \frac{x}{l_1} \right\}$$

and dg represent m .

Thus the ordinate fg represents M , the bending moment at x .

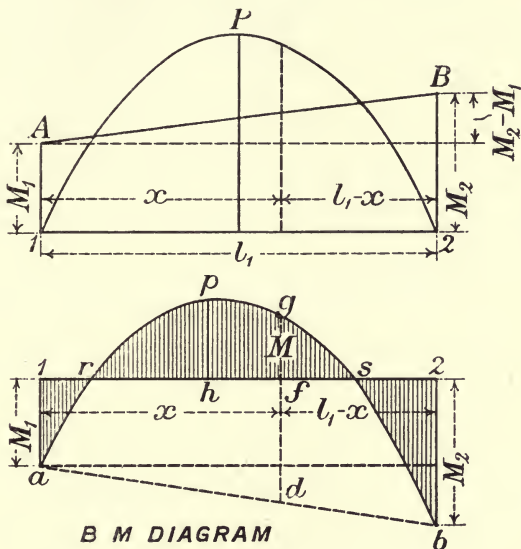

Fig. 76.

The parabola can be drawn independently by finding $x = 1h$ the section of maximum bending moment from Equation 6, Art. 52, and substituting this value of x in equation

$$M = -M_1 - (M_2 - M_1) \frac{x}{l_1} + \frac{w_1 x}{2} (l_1 - x).$$

Draw hp vertical to represent the corresponding value of M ; then p is the vertex of parabola.

The points of inflection are at r and s where $M = 0$.

The bending moment at any section is represented by the ordinate of the shaded area.

54. Theorem of three moments.

To determine a relation between the *bending moments at any three consecutive supports* of a uniform and uniformly loaded

continuous girder resting on a number of supports, all of which are on the same level.

Let 1, 2, 3 be three consecutive supports on the same level for a continuous girder over any number of spans (Fig. 77).

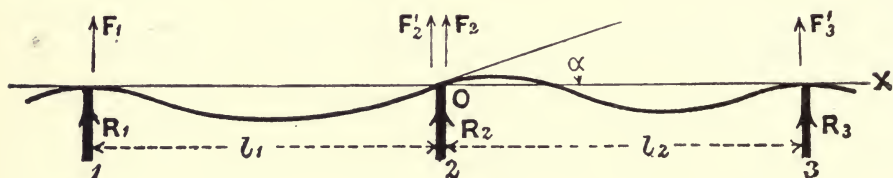

Fig. 77.

Let l_1 = length of span 1—2.

„ l_2 = length of span 2—3.

„ w_1, w_2 = loads per unit of length on the spans 1—2, 2—3, respectively.

„ R_1, R_2, R_3 be the reactions at supports 1, 2, 3, respectively.

„ M_1, M_2, M_3 be the bending moments at 1, 2, 3, respectively.

„ F_1 be the shear on a section in span 1—2, very close to support 1.

„ F_2' be the shear on a section in span 1—2, very close to support 2.

„ F_2 be the shear on a section in span 2—3, very close to support 2.

„ F_3' be the shear on a section in span 2—3, very close to support 3.

„ a be the angle which the tangent to the girder at 2 makes with the horizontal.

Take O at support 2 as origin, and 2—3 as the axis of x .

Consider the span 2—3. The bending moment at any point (x, y) is

$$EI \frac{d^2y}{dx^2} = M = M_2 + F_2 x - \frac{w_2 x^2}{2} \dots \dots \dots (1)$$

at support 3 ; $x = l_2$ and $M = M_3$.

Therefore
$$M_3 = M_2 + F_2 l_2 - \frac{w_2 l_2^2}{2} \dots \dots \dots (2).$$

Integrating Equation (1),

$$EI \frac{dy}{dx} = M_2 x + \frac{1}{2} F_2 x^2 - \frac{w_2 x^3}{6} + C$$

when $x = 0, \frac{dy}{dx} = \tan \alpha$; hence $C = EI \tan \alpha$.

Therefore

$$EI \left(\frac{dy}{dx} - \tan a \right) = M_2 x + \frac{1}{2} F_2 x^2 - \frac{w_2 x^3}{6}.$$

Integrating again,

$$EI (y - x \tan a) = \frac{1}{2} M_2 x^2 + \frac{1}{6} F_2 x^3 - \frac{w_2 x^4}{24}.$$

There is no constant of integration, for when $x = 0$; $y = 0$.

Again, when $x = l_2$; $y = 0$, hence,

$$-EI \tan a = \frac{1}{2} M_2 l_2 + \frac{1}{6} F_2 l_2^2 - \frac{w_2 l_2^3}{24}.$$

Substituting for F_2 its value from (2), we get

$$-EI \tan a = \frac{M_3 l_2}{6} + \frac{M_2 l_2}{3} + \frac{w_2 l_2^3}{24} \dots \dots \dots (3).$$

Similarly for the span 1—2, we get by substituting $-\tan a$ for $\tan a$,

$$EI \tan a = \frac{M_1 l_1}{6} + \frac{M_2 l_1}{3} + \frac{w_1 l_1^3}{24} \dots \dots \dots (4).$$

Hence by adding (3) and (4),

$$(M_1 + 2M_2) l_1 + (M_3 + 2M_2) l_2 + \frac{1}{4}(w_1 l_1^3 + w_2 l_2^3) = 0 \dots \dots (5).$$

This relation is called the *theorem of the three moments*. If there are n supports, we get $n - 2$ equations connecting the corresponding bending moments, and two other equations are given by the conditions of support at the ends. Thus, if the girder is merely supported at the ends, $M_1 = 0$ and $M_n = 0$; if an end is fixed $\frac{dy}{dx} = 0$ at that support. From the values of M_1, M_2, \dots, M_n thus obtained we can determine the bending moment at any section of a given span.

The section of maximum bending moment is got by making $\frac{dM}{dx} = 0$; and the points of inflection by solution of the equation

$$M = 0.$$

Thus considering span 2—3,

$$M = M_2 + F_2 x - \frac{w_2 x^2}{2},$$

$$\frac{dM}{dx} = F_2 - w_2 x = 0.$$

Therefore

$$x = \frac{F_2}{w_2},$$

and max. bending moment = $M_2 + \frac{F_2^2}{2w_2}$.

For concentrated loads, the theorem of three moments becomes

$$(M_1 + 2M_2) l_1 + (M_3 + 2M_2) l_2 + \sum \frac{W_1 x_1}{l_1} (l_1^2 - x_1^2) + \sum \frac{W_2 x_2}{l_2} (l_2^2 - x_2^2) = 0,$$

where W_1 and W_2 are the loads in the two spans l_1 and l_2 respectively, and x_1 and x_2 the distances of those loads to the supports at the extremities of the span under consideration. If there are a number of loads in one span take the algebraic sum of the moments, *i.e.* $\sum Wx$.

55. Reactions.

The reaction at any support is the sum of the shearing forces on each side of that support. This is evident if we consider the separate equilibrium of the *very small* portion of the girder between the sections on which F_2 and F_2' act; the reaction R_2 , which is equal and opposite to the pressure on the support, must for equilibrium be equal to the sum of the shearing forces, thus

$$R_2 = F_2 + F_2' \dots \dots \dots (6).$$

and at any support n $R_n = F_n + F_n' \dots \dots \dots (7).$

At the two extreme ends, where the girder is merely supported, the reaction is equal to the shearing force.

To find the reaction R_2 at support 2 (Fig. 77).

Consider the equilibrium of the span 2—3. Taking moments about support 3, we get

$$M_3 = F_2 l_2 - \frac{w_2 l_2^2}{2} + M_2,$$

or
$$F_2 = \frac{M_3 - M_2}{l_2} + \frac{w_2 l_2}{2} \dots \dots \dots (8).$$

Again, considering the span 1—2,

$$M_1 = F_2' l_1 - \frac{w_1 l_1^2}{2} + M_2,$$

or
$$F_2' = \frac{M_1 - M_2}{l_1} + \frac{w_1 l_1}{2} \dots \dots \dots (9).$$

Therefore, by adding (8) and (9),

$$R_2 = \frac{M_1 - M_2}{l_1} + \frac{M_3 - M_2}{l_2} + \frac{w_1 l_1}{2} + \frac{w_2 l_2}{2} \dots \dots \dots (10);$$

and generally at any intermediate support n separating the spans l_{n-1} and l_n ,

$$R_n = \frac{M_{n-1} - M_n}{l_{n-1}} + \frac{M_{n+1} - M_n}{l_n} + \frac{w_{n-1} l_{n-1}}{2} + \frac{w_n l_n}{2} \dots \dots (11).$$

If there are r supports, 1, 2, 3, ..., r , with spans l_1, l_2, \dots, l_{r-1} , and the girder is free over the supports 1 and r , then evidently

$$R_1 = F_1 = \frac{M_2}{l_1} + \frac{w_1 l_1}{2}, \dots \dots \dots (12),$$

and

$$R_r = F_r' = \frac{M_{r-1}}{l_{r-1}} + \frac{w_{r-1} l_{r-1}}{2} \dots \dots \dots (13).$$

Thus, having found the values of the moments at each support by the equation of the theory of three moments, the reactions can be at once obtained.

EXAMPLES.

1. Find the bending moment at the middle support of a continuous girder of two unequal spans, the left one of length 60 feet, and the right one of length 40 feet. The dead load on each girder is 1 ton per foot run. The live load of 2 tons covers only the 60 feet span. Find also the reactions at each support.

Adopting the notation of previous articles,

$$l_1 = 60 \text{ feet, } l_2 = 40 \text{ feet,}$$

$$w_1 = 3 \text{ tons per foot run, } w_2 = 1 \text{ ton per foot run.}$$

Equation of three moments is

$$(M_1 + 2M_2)l_1 + (M_3 + 2M_2)l_2 = -\frac{1}{4}(w_1 l_1^3 + w_2 l_2^3),$$

but as in this case $M_1 = M_3 = 0$, we get

$$8M_2(l_1 + l_2) = -w l_1^3 - w_2 l_2^3$$

$$800M_2 = -3 \times 216000 - 64000$$

$$M_2 = -890 \text{ foot tons.}$$

Taking moments about support 2, or from (12), Art. 55,

$$R_1 = \frac{-890}{60} + \frac{3 \times 60}{2}$$

$$= 75.17 \text{ tons.}$$

By Equation (10), Art. 55, putting $M_1 = 0$, $M_2 = -890$, $M_3 = 0$,

$$R_2 = \frac{890}{60} + \frac{890}{40} + \frac{3 \times 60}{2} + \frac{1 \times 40}{2}$$

$$= 147.08 \text{ tons.}$$

Taking moments about support 2, or by Equation (13), Art. 55,

$$R_3 = \frac{-890}{40} + \frac{1 \times 40}{2}$$

$$= -2.25 \text{ tons.}$$

To verify the results.—The total load on girder = 220 tons,

and the sum of the reactions should be equal to this total load, that is

$$R_1 + R_2 + R_3 = w_1 l_1 + w_2 l_2,$$

$$75 \cdot 17 + 147 \cdot 08 - 2 \cdot 25 = 180 + 40,$$

or $220 = 220,$

which shows that R_1, R_2, R_3 are correct.

2. *A continuous girder of three spans has two equal end spans of 240 feet and a centre span of 150 feet; the supports are level and the girders are free over the abutment piers, and are assumed to be of uniform section. The fixed load carried by each girder is $\frac{1}{2}$ ton per foot, and the moving load is 1 ton per foot. Calculate the bending moments over the two central supports when the left end span only is covered by the moving load, and then determine the maximum positive bending moment occurring on a section in that span. Find also the reactions at each support.*

Adopting the notation of previous articles, we have

$$l_1 = 240 \text{ feet, } l_2 = 150 \text{ feet, } l_3 = 240 \text{ feet,}$$

$$w_1 = 1\frac{1}{2} \text{ ton per foot, } w_2 = w_3 = \frac{1}{2} \text{ ton per foot,}$$

$$M_1 = M_4 = 0.$$

Equation of three moments for spans 1—2, 2—3, is

$$(M_1 + 2M_2)l_1 + (M_3 + 2M_2)l_2 = -\frac{(w_1 l_1^3 + w_2 l_2^3)}{4}.$$

Substituting the numerical values above, we get

$$8M_2(240 + 150) + 4M_3 \times 150 = -\frac{3}{2} \times 240^3 - \frac{1}{2} \times 150^3,$$

or $5 \cdot 2M_2 + M_3 = -37372 \cdot 5 \dots\dots\dots (A).$

For spans 2—3, 3—4, similarly

$$5 \cdot 2M_3 + M_2 = -14332 \cdot 5 \dots\dots\dots (B).$$

Solving for M_2 from Equations (A) and (B), we get

$$26 \cdot 04M_2 = -180004 \cdot 5,$$

or $M_2 = -6912 \cdot 6 \text{ foot tons,}$

and $M_3 = -37372 \cdot 5 - 5 \cdot 2 \times -6912 \cdot 6$
 $= -1427 \text{ foot tons.}$

Maximum positive bending moment, span 1—2.

At any section distant x from support 1 the bending moment is

$$M = M_1 + F_1 x - \frac{wx^2}{2} \dots\dots\dots (C).$$

At support 2, where $x = l_1, M = M_2,$ and

$$M_2 = M_1 + F_1 l_1 - \frac{w_1 l_1^2}{2},$$

or $F_1 = \frac{M_2 - M_1}{l_1} + \frac{w_1 l_1}{2} \dots\dots\dots (D).$

Substituting in (C),

$$M = M_1 + (M_2 - M_1) \frac{x}{l_1} + \frac{w_1 x}{2} (l_1 - x) \dots \dots \dots (E);$$

but since $M_1 = 0$, $M = M_2 \frac{x}{l_1} + \frac{w_1 x}{2} (l_1 - x)$

$$= \frac{3}{4} x (240 - x) - \frac{x}{240} \times 6912 \cdot 6;$$

this will have its maximum positive value when $\frac{dM}{dx} = 0$, that is

$$180 - \frac{3}{2} x - 28 \cdot 8 = 0,$$

or $x = 100 \cdot 8$ feet from support 1.

The *maximum* value of M required is

$$M = \frac{3}{4} \times 100 \cdot 8 \times 139 \cdot 2 - 100 \cdot 8 \times 28 \cdot 8$$

$$= +7620 \cdot 5 \text{ foot tons.}$$

Reactions. Using the notation of Art. 55, we have

$$M_1 = M_4 = 0.$$

Taking moments about support 2,

$$R_1 = F_1 = \frac{M_2 - M_1}{l_1} + \frac{w_1 l_1}{2} = \frac{-6912}{240} + \frac{3}{4} \times 240$$

$$= \underline{151 \cdot 2 \text{ tons.}}$$

Taking moments about support 1,

$$F'_2 = \frac{M_1 - M_2}{l_1} + \frac{w_1 l_1}{2} = \frac{+6912}{240} + \frac{3}{4} \times 240 = 208 \cdot 8 \text{ tons.}$$

Taking moments about support 3,

$$F_2 = \frac{M_3 - M_2}{l_2} + \frac{w_2 l_2}{2} = \frac{+5485}{150} + \frac{1}{4} \times 150 = 74 \cdot 1 \text{ tons,}$$

and $R_2 = F_2 + F'_2 = 74 \cdot 1 + 208 \cdot 8 = \underline{282 \cdot 9 \text{ tons.}}$

Taking moments about support 2,

$$F'_3 = \frac{M_2 - M_3}{l_2} + \frac{w_2 l_2}{2} = \frac{-5485}{150} + \frac{1}{4} \times 150 = 0 \cdot 9 \text{ ton.}$$

Taking moments about support 4,

$$F_3 = \frac{M_4 - M_3}{l_3} + \frac{w_3 l_3}{2} = \frac{+1427}{240} + \frac{1}{4} \times 240 = 65 \cdot 9 \text{ tons,}$$

and $R_3 = F_3 + F'_3 = 65 \cdot 9 + 0 \cdot 9 = \underline{66 \cdot 8 \text{ tons.}}$

Taking moments about support 3,

$$R_4 = F'_4 = \frac{M_3 - M_4}{l_3} + \frac{w_3 l_3}{2} = \frac{-1427}{240} + \frac{1}{4} \times 240 = -5 \cdot 9 + 60 = \underline{54 \cdot 1 \text{ tons.}}$$

To verify the accuracy,

$$R_1 + R_2 + R_3 + R_4 = 151.2 + 282.9 + 66.8 + 54.1 = 555,$$

which must be equal to

$$w_1 l_1 + w_2 l_2 + w_3 l_3 = 360 + 75 + 120 = 555.$$

Again, the sum of the shears at the supports *in any one span* should be equal to the total load on that span. Thus for span 2—3 on which the total load is $w_2 l_2 = 75$ tons, we have

$$F_2 + F'_3 = 74.1 + 0.9 = 75 \text{ tons.}$$

The shearing force diagram is shown in Fig. 78.

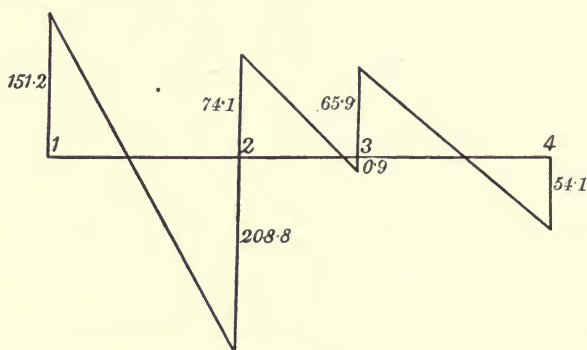

Fig. 78.

56. Concentrated loads.

Considering as before two consecutive spans of length l_1 and l_2 , resting on three supports 1, 2, 3 all on the same level, the theorem of three moments becomes

$$M_1 l_1 + 2M_2(l_1 + l_2) + M_3 l_2 + \frac{W_1 x_1}{l_1}(l_1^2 - x_1^2) + \frac{W_2 x_2}{l_2}(l_2^2 - x_2^2) = 0 \quad (1)$$

where W_1 and W_2 are the loads in the two spans l_1 and l_2 respectively, the load W_1 being distant x_1 from support 1, and W_2 distant x_2 from support 2.

For several loads on each span the above equation becomes

$$M_1 l_1 + 2M_2(l_1 + l_2) + M_3 l_2 = -\sum \frac{W_1 x_1}{l_1}(l_1^2 - x_1^2) - \sum \frac{W_2 x_2}{l_2}(l_2^2 - x_2^2) \quad (2)$$

TWO EQUAL SPANS.

Case I. Load W_1 on first span 1—2, distant x_1 from support 1. Let l = length of span.

∴ M_1, M_2, M_3 be the moments at supports 1, 2, 3 respectively.

∴ R_1, R_2, R_3 be the reactions at supports 1, 2, 3 respectively.

From Equation (1), since $M_1 = M_3 = 0$,

$$4 M_2 l = -W_1 \frac{x_1}{l} (l^2 - x_1^2).$$

Therefore, $M_2 = -\frac{W_1 x_1}{4l^2} (l^2 - x_1^2) \dots \dots \dots (3)$

Taking moments about support 2,

$$R_1 l = M_2 + W_1 (l - x_1).$$

$$\therefore R_1 = +\frac{W_1}{l} (l - x_1) - \frac{W_1 x_1}{4l^2} (l^2 - x_1^2) \dots \dots \dots (4)$$

Similarly, $R_3 = \frac{M_2}{l} = -\frac{W_1 x_1}{4l^3} (l^2 - x_1^2) \dots \dots \dots (5)$

Since $R_1 + R_2 + R_3 = W_1$

$$\begin{aligned} \therefore R_2 &= W_1 - R_1 - R_3 \\ &= \frac{W_1 x_1}{l} + \frac{W_1 x_1}{2l^3} (l^2 - x_1^2) \dots \dots \dots (6) \end{aligned}$$

From Equations (4), (5), (6) we see that for a load on the first span

- R_1 is always positive,
- R_2 is always positive,
- R_3 is always negative.

For a load W_2 on second span 2—3, distant x_2 from pier 3,

$$\begin{aligned} R_1 &= -\frac{W_2 x_2}{4l^3} (l^2 - x_2^2), \\ R_2 &= \frac{W_2 x_2}{l} + \frac{W_2 x_2}{2l^3} (l^2 - x_2^2), \\ R_3 &= \frac{W_2}{l} (l - x_2) - \frac{W_2 x_2}{4l^3} (l^2 - x_2^2). \end{aligned}$$

Hence for a load on the second span 2—3, R_1 is always negative.

POINTS OF INFLECTION.

For any section at distance x from support 1, between support 1 and the load W_1 ,

$$M = R_1 x,$$

and since R_1 is always positive, this moment must be always positive.

For a section distant x from support 1, between the load W_1 and support 2,

$$M = R_1 x - W_1 (x - x_1).$$

Substituting for R_1 its value in Equation 4

$$\begin{aligned} M &= \left\{ \frac{W_1}{l} (l - x_1) - \frac{W_1 x_1}{4l^3} (l^2 - x_1^2) \right\} x - W_1 (x - x_1) \\ &= W_1 x_1 \left(1 + \frac{5x}{4l} - \frac{x x_1^2}{4l^3} \right) \dots \dots \dots (7) \end{aligned}$$

At the points of inflection $M = 0$,

$$\therefore 1 - \frac{5x}{4l} - \frac{xx_1^2}{4l^3} = 0,$$

or
$$x = \frac{4l^3}{5l^2 - x_1^2} \dots\dots\dots (8).$$

In Equation (8), if $x_1 = 0$, $x = \frac{4}{5}l$;

if $x_1 = l$, $x = l$;

so that for a load in the first span, the inflection point must be situated somewhere in the length $\frac{l}{5}$ measured from support 2 towards support 1.

57. Maximum shearing forces and maximum bending moments in a continuous girder due to live load.

In order to determine the maximum and minimum stresses in the web and chord members of a continuous girder, it is necessary to know what distribution of the live load causes (a) the greatest positive and negative shearing forces, and (b) the greatest positive and negative bending moments.

MAXIMUM SHEARS.

By Art. 56 we have seen that for all loads on the left-hand span 1—2 the reaction R_1 is positive and R_3 negative.

For all loads on the right-hand span 2—3, R_1 is negative.

Let F = shearing force on a section K in span 1—2 (Fig. 79).

Then, if we take the shear on any section as being equal in magnitude and opposite in sense to the resultant force at the section

$$F = -(R_1 - \Sigma W_1)$$

where ΣW_1 represents all the loads on left of section.

From the above it can be seen at once that—

The maximum negative shear on any section K in the left-hand span 1—2 occurs when live load extends from the section K to the middle support 2, the right-hand span 2—3 being unloaded (Fig. 79).

The maximum positive shear at the same section occurs when the live load covers the portion of left-hand span between section K and left support 1, and also covers the second span 2—3 (Fig. 79)

MAXIMUM MOMENTS.

The bending moment at any section distant x from left support 1 is

$$M = R_1x - \Sigma W(x - x_1).$$

In Art. 56 it was shown that for two equal spans R_1 is always positive for all loads on left-hand span 1—2, also that the inflection point, where M is zero (and consequently the bending moment passes from a positive to a negative value), is always situated in the end $\frac{1}{5}$ th of the span 1—2 nearest support 2.

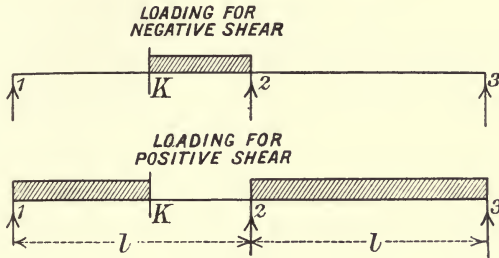

Fig. 79.

Thus for any section on the portion $\frac{4}{5}l$ measured from 1, the bending moment due to any load W is always *positive*, whereas the bending moment on a section between $\frac{4}{5}l$ and support 2 may be either positive or negative. There are thus two separate cases to consider.

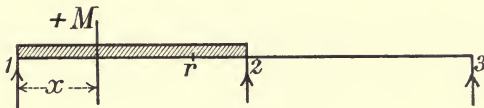

Fig. 80.

I. *A section between left support 1 and point of inflection r .*

Maximum positive moment.—For all loads on left span 1—2, R_1 is positive.

For all loads on right span 2—3, R_1 is negative.

Thus all loads on left span produce a positive bending moment on all sections to left of r .

And all loads on right span produce a negative bending moment on all sections to left of r .

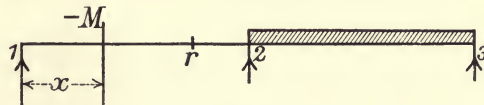

Fig. 81.

Hence, maximum positive bending moment on any section to left of r is produced when live load covers the left span 1—2, and the maximum negative bending moment at any section to left of r occurs when live load covers the right span 2—3 (Figs. 80 and 81).

II. A section between $x = \frac{4}{5}l$ and support 2.

From Equation (8), Art. 56, the position of load for zero bending moment is given by

$$x_1 = l \sqrt{5 - \frac{4l}{x}} \dots\dots\dots(9)$$

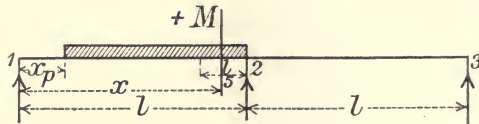

Fig. 82.

From Equation (7) it is seen that if x is greater than $\frac{4}{5}l$, which is the case we are considering, that

Bending moment is positive if $x_1 > l \sqrt{5 - \frac{4l}{x}}$

Bending moment is negative if $x_1 < l \sqrt{5 - \frac{4l}{x}}$

and we have seen that

Bending moment is negative for all loads on span 2—3, since R_1 is then negative.

Equation (9) gives the limiting value of x_1 —, call it x_p . Hence, maximum positive moment on the section occurs when live load covers the portion of span 1—2 between x_p and support 2, span 2—3 being unloaded (Fig. 82).

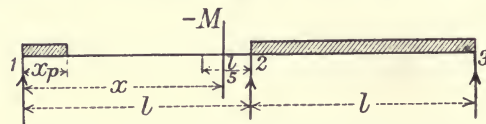

Fig. 83.

Maximum negative moment on the section occurs when live load covers only the portion x_p of span 1—2, and the whole of the span 2—3 (Fig. 83).

EXAMPLE.

A continuous girder 160 feet long of the form shown in Fig. 84 is built over two equal spans of 80 feet. The length of each panel is 16 feet and depth 9 feet. If the dead load per panel point is $7\frac{1}{2}$ tons and the panel live load is 15 tons, both carried on the top chord, determine the stresses in the inclined web members, and in the bays IJ of upper chord and CD of lower chord.

The half-loads at the end panel points G and G' only affect the stresses in the end posts, so may be omitted. If the loads

were carried on bottom chord, GH and GA would be superfluous. As regards the centre load, we see from Equations (4) and (5), Art. 56, if $x_1=l$ that R_1 and $R_3 = 0$, and from Equation (6) that $R_2=W_1=15$ tons; consequently this centre load can be neglected in the calculation of stresses, as it affects only the central post.

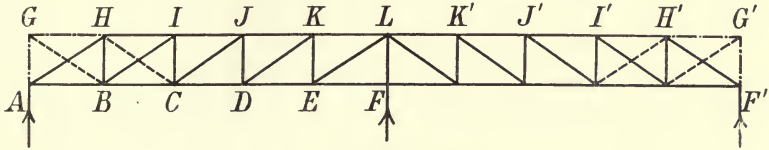

Fig. 84.

Inclined braces.—The maximum and minimum stresses in inclined braces are got from the maximum and minimum shears.

$$\text{Stress} = F \operatorname{cosec} \theta,$$

θ being the angle which the member makes with the horizontal, To get the shears, the reactions must first be calculated from Equations (4), (5), (6), Art. 56, for each separate load, then the total reaction is the sum of the partial reactions due to any loads on girder.

Table of Reactions.

Load at	H	I	J	K	K'	J'	I'	H'
R_1	+ 11·28	+ 7·74	+ 4·56	+ 1·92	- 1·08	- 1·44	- 1·26	- 0·72
R_2	+ 4·44	+ 8·52	+ 11·88	+ 14·16	+ 14·16	+ 11·88	+ 8·52	+ 4·44
R_3	- 0·72	- 1·26	- 1·44	- 1·08	+ 1·92	+ 4·56	+ 7·74	+ 11·28

To find the maximum positive and negative shears for HC or IB .

Maximum negative shear in HC or IB occurs when joints I, J, K are loaded (Art. 57).

$$\text{From the table of reactions } R_1 = 7\cdot74 + 4\cdot56 + 1\cdot92 \\ = 14\cdot22$$

$$\therefore F_1 = -14\cdot22 \text{ tons.}$$

Maximum positive shear in HC or IB occurs when all the other joints are loaded; I, J, K being unloaded

$$R_1 = 6\cdot78, \\ F_2 = -(6\cdot78 - 15) = +8\cdot22 \text{ tons.}$$

The remainder of the following table is got in the same manner.

The dead load is half the live load; therefore dead load shears

are half the live load shears when the girder is fully loaded with live load.

$$\text{Stress in inclined brace} = F \operatorname{cosec} \theta,$$

$$\operatorname{cosec} \theta = 2.04.$$

Table of Stresses in Inclined Braces.

Member	Live Load Shear		Shear due to Live Load Covering Whole Girder	Dead Load Shear	Maximum Shear	Minimum Shear	Max. Stress	Min. Stress
	Negative	Positive						
<i>GB</i>	-25.5	+ 4.5	- 21	- 10.5	- 36	- 6	- 73.4	- 12.2
<i>HC</i>	- 14.2	+ 8.2	- 6	- 3	- 17.2	+ 5.2	- 35.1	+ 10.6
<i>JC</i>	- 6.48	+ 15.48	+ 9	+ 4.5	+ 19.98	- 1.98	+ 40.8	- 4.04
<i>KD</i>	- 1.92	+ 25.92	+ 24	+ 12	+ 37.92	+ 10.08	+ 77.4	+ 20.6
<i>LE</i>	- 0	+ 39	+ 39	+ 19.5	+ 58.5	+ 39	+ 119.3	+ 79.6

- sign tension, + sign compression.

Stresses in upper and lower chords.

Members *IJ* (top chord) and *CD* (lower chord).

IJ.—The maximum positive moment for *IJ* due to live load occurs when the left span is fully loaded as in Fig. 80, then

$$R_1 = 25.5 \text{ tons,}$$

and with centre of moments *C*

$$M = 25.5 \times 32 - 15 \times 16$$

$$= + 576 \text{ foot tons.}$$

The maximum negative moment for *IJ* due to live load occurs when the right-hand span is fully loaded.

Then $R_1 = -4.5$ tons.

$$M = -4.5 \times 32 = -144 \text{ foot tons.}$$

Hence, when live load covers the whole girder

$$M = + 576 - 144 = + 432.$$

Therefore, for dead load $M = \frac{+ 432}{2} = + 266.$

Maximum moment = $+ 266 + 576 = + 842$ foot tons.

Minimum moment = $+ 266 - 144 = + 122$ foot tons.

Maximum stress = $+ \frac{842}{9} = + 93.5$ tons compression.

Minimum stress = $+ \frac{122}{9} = + 13.5$ tons compression.

Member *CD* lower chord.

Centre of moments *J*.

Maximum positive moment

$$= 25.5 \times 48 - 16(1+2) 15 \\ = +504 \text{ foot tons.}$$

Maximum negative moment

$$= -4.5 \times 48 \\ = -216 \text{ foot tons.}$$

∴ Live load covering whole girder $M = +288$ foot tons.

Hence, dead load moment $M = +144$ foot tons.

Maximum moment $= +144 + 504 = +648$.

Minimum moment $= +144 - 216 = -72$.

Maximum stress $= -\frac{648}{9} = -72$ tons tension.

Minimum stress $= +\frac{72}{9} = +8$ tons compression.

A positive moment causes tension in the lower chord.

A negative moment causes compression in the lower chord.

The positive sign + is used for compression; the negative sign - for tension.

In the same way the maximum and minimum stresses in the other chord members can be got at once.

The greatest positive bending moment due to live load at the point L over centre support is zero. The greatest negative bending moment at L due to live load is when the whole girder is covered.

In the case of a *swing bridge* the stresses are found very much on the same lines as above, but the depth at centre is usually greater than at the ends, giving a sloping top chord.

58. Supports not on the same level.

One of the drawbacks to the use of continuous girders is the change in the value of the stress due to the settlement of one of the masonry piers, or the expansion and contraction of iron piers.

The general equation for two consecutive spans of a continuous girder with piers at different levels is

$$M_1 l_1 + 2M_2(l_1 + l_2) + M_3 l_2 \\ = \frac{w_1 l_1^3}{4} - \frac{w_2 l_2^3}{4} - 6EI \left(\frac{h_2 - h_1}{l_1} + \frac{h_2 - h_3}{l_2} \right) \dots \dots (1)$$

where l_1 and l_2 are the lengths of the spans 1—2, 2—3 respectively,

w_1 and w_2 the uniform load per unit of length on l_1 and l_2 ,

h_1, h_2, h_3 the heights of the piers 1, 2, 3 respectively above a fixed horizontal datum.

If we omit the loading, we get the equation for two consecutive spans,

$$M_1 l_1 + 2M_2(l_1 + l_2) + M_3 l_2 = -6EI \left(\frac{h_2 - h_1}{l_1} + \frac{h_2 - h_3}{l_2} \right) \dots \dots (2),$$

from which we obtain the increase or diminution of the bending moments at the piers due to an alteration of level of supports; and from these moments the consequent alteration is the value of the pier reactions, and the stresses in members of girder.

Thus, if a continuous girder of two spans l_1 and l_2 rests freely on two end supports which are on the same level, and the central support settles through a vertical height of h_0 , find the alteration in the bending moment at this support.

By Equation (2), since $M_1 = M_3 = 0$, and as in this case h_0 is a settlement

$$h_2 - h_1 = -h_0; \quad h_2 - h_3 = -h_0.$$

$$\begin{aligned} \text{Hence, } 2M_2(l_1 + l_2) &= -6EI \left(\frac{-h_0}{l_1} + \frac{-h_0}{l_2} \right) \\ &= +6EI h_0 \frac{(l_1 + l_2)}{l_1 l_2}. \end{aligned}$$

$$\text{Therefore, } M_2 = + \frac{3EI h_0}{l_1 l_2} \dots \dots \dots (3).$$

This expression gives the diminution in the amount of the negative bending moment at support 2 due to the sinking of the centre support.

If the spans are of equal length l ,

$$M_2 = + \frac{3EI h_0}{l^2} \dots \dots \dots (4).$$

EXAMPLES.

1. Two equal spans of 20 feet are spanned by a girder the cross-section of which consists of a steel joist 18" x 7" weighing 75 lbs. per foot and two flats 10" x 5/8" riveted to each flange. Area of cross-section, 47.06 square inches; moment of inertia, 3128 inch units. If the central support settles 0.10 inch, determine the bending moment at this support. The girder carries a uniform load of 1 ton per foot run.

For two equal spans with level supports

$$\begin{aligned} M_2 &= - \frac{wl^2}{8} = - \frac{1 \times 400}{8} \\ &= -50 \text{ foot tons} = -600 \text{ inch tons.} \end{aligned}$$

Moment due to settlement from Equation (4), $E = 13,000$ tons per square inch.

$$M_2 = + \frac{3 \times 13000 \times 3128 \times 0.1}{400 \times 144}$$

$$= + 212 \text{ inch tons.}$$

Thus at central pier

$$M_2 = -600 + 212 = -388 \text{ inch tons.}$$

2. If a continuous girder crosses four equal spans of length l , and the central pier settles through a height h_0 , find the increase in the moment over the support 2 due to this settlement.

From Equation (2), since $M_1 = M_5 = 0$,

$$4M_2 + M_3 = -\frac{6EIh_0}{l^2},$$

$$M_2 + 4M_3 + M_4 = +\frac{12EIh_0}{l^2},$$

$$M_3 + 4M_4 = -\frac{6EIh_0}{l^2},$$

$$\therefore M_2 = -\frac{18EIh_0}{7l^2}, \quad M_3 = +\frac{30EIh_0}{7l^2},$$

$$R_1 = \frac{M_2}{l} = -\frac{18EIh_0}{7l^3}.$$

M_2 being negative, is the increase of moment at support 2 due to settlement?

R_1 is the negative reaction at pier 1 due to the settlement.

59. Advantages and disadvantages of continuous girders.

In the case of separate spans the bending moment is greatest near the centre, whereas in the continuous girder the maximum bending moments occur near the supports, also the average value of the bending moment is less; thus there is a saving in the flange material, and the heavier sections are placed over the supports, which means that a portion of the weight is removed from the centre towards the supports.

The disadvantages of continuity are chiefly due to the effect of rolling loads which alter the positions of the points of inflection, and portions of the span are subjected to bending moments which change in sign and amount, the members there being exposed to stresses which are alternately tensile and compressive, especially when the dead load on the bridge is light as compared with the live load. Another disadvantage of continuous girders is that settlement in the supports also causes the points of inflection to change, and may considerably alter the stresses calculated on the assumption that all the supports are level. The Moment of Inertia I is not constant; it is subject to variation.

CHAPTER X.

CANTILEVER GIRDERS—SUSPENSION AND STIFFENING GIRDERS.

60. The disadvantages of continuous girders are removed if hinges are introduced at the points of contrary flexure. The bridge is then composed of cantilevers and suspended girders; and there is no ambiguity regarding the stresses. The advantage of the continuous girder is preserved, and its chief disadvantage is avoided.

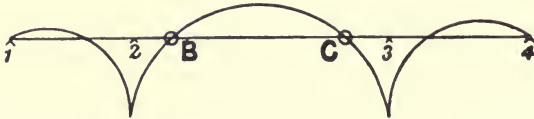

Fig. 85.

In Fig. 85 let 1, 2, 3, 4 be the points of support :

(a) The hinges may be introduced in the central span at *B* and *C*, then these points become the points of contrary flexure; and the portion *BC* may be treated as an independent girder supported at the ends by the cantilever arms *2B* and *3C*. In this case the side spans must be anchored down at 1 and 4, as the

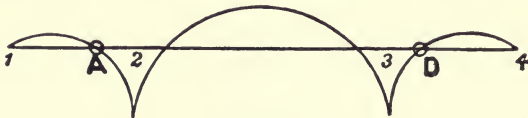

Fig. 86.

reactions at these points may become negative—that is, the girders may exert a lifting force.

The line *BC* becomes the datum line for the bending moment diagram.

(b) The hinges may be introduced in the side spans at *A* and *D* (Fig. 86). In this case the reactions at 1 and 4 are always

positive, as the girders cannot exert any lifting force at these points.

NOTE.—The hinges may be placed in the central span or in the side spans, but *not* in both.

61. CASE A. Hinges in the central span (Fig. 87).

I. Uniform load of intensity w per foot run.

Let R_1, R_2, R_3, R_4 be the reactions at the points of support 1, 2, 3, 4 respectively.

Assume the spans symmetrical.

Let l_1 be the length of each of the two side spans.

„ a be the distance from support 2 to the first hinge B .

„ b be the distance between the hinges B and C .

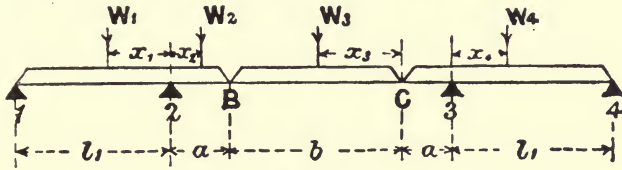

Fig. 87.

Now treat the portion BC as an independent girder supported at the ends. The stresses in it are those due to its own loads only. $1B$ and $4C$ can also be treated as independent girders loaded with their own loads, and the weights at the ends B and C equal to the reactions at these points due to the load on the girder BC .

The bending moments at piers 2 and 3 are

$$M_2 = M_3 = -\frac{wa^2}{2} - \frac{wb}{2} a = -\frac{w}{2} (a^2 + ab).$$

To find R_2 , take moments about pier 2,

$$R_1 l_1 - \frac{wl_1^2}{2} + \frac{wa^2}{2} + \frac{wb}{2} a = 0,$$

$$R_1 = \frac{wl_1}{2} - \frac{w}{2} \left(\frac{a^2 + ab}{l_1} \right).$$

To find R_1 , take moments about pier 1,

$$-R_2 l_1 + \frac{wl_1^2}{2} + wa \left(l_1 + \frac{a}{2} \right) + \frac{wb}{2} (l_1 + a),$$

$$R_2 = \frac{w}{2} (l_1 + 2a + b) + \frac{w}{2} \left(\frac{a^2 + ab}{l_1} \right).$$

$$R_1 = R_4 \text{ and } R_2 = R_3 \text{ from symmetry.}$$

II. Concentrated loads.

A load W_1 on the side span 1—2 distant x_1 from pier 2.

A load W_2 on the cantilever arm 2B distant x_2 from pier 2.

A load W_3 on the suspended girder distant x_3 from hinge C.

A load W_4 on the side span 3—4 distant x_4 from pier 3.

$$\text{Load at } B = \frac{W_3 x_3}{b}; \quad \text{Load at } C = W_3 \left(\frac{b - x_3}{b} \right).$$

Bending moment at pier 2,

$$M_2 = W_2 x_2 + W_3 x_3 \frac{a}{b}.$$

Bending moment at pier 3,

$$M_3 = W_3 \left(\frac{b - x_3}{b} \right) a.$$

To find R_1 , take moments about 2,

$$R_1 l_1 = W_1 x_1 - W_2 x_2 - \frac{W_3 x_3}{b} a = W_1 x_1 - M_2.$$

To find R_4 , take moments about 3,

$$R_4 l_1 = W_4 x_4 - W_3 \left(\frac{b - x_3}{b} \right) a = W_4 x_4 - M_3.$$

To find R_2 , take moments about 1,

$$R_2 l_1 = W_1 (l_1 - x_1) + W_2 (l_1 + x_2) + \frac{W_3 x_3}{b} (l_1 + a).$$

To find R_3 , take moments about 4,

$$R_3 l_1 = W_3 \left(\frac{b - x_3}{b} \right) (l_1 + a) - W_4 (l_1 - x_4).$$

We see in both the cases considered, that

$$\begin{aligned} R_1 \text{ and } R_4 \text{ may be negative,} \\ R_2 \text{ and } R_3 \text{ are always positive.} \end{aligned}$$

The pier moments are determined solely by the loads on the span containing the hinges, *i.e.* the central span.

62. CASE B. Bridge hinged in the side spans.

Let B and C be the hinges in this case (Fig. 88).

The portions 1B and 4C may be considered as independent girders supported at the ends, and the part BC as an independent girder supported at 2 and 3, carrying its own loads, and in addition the weights at B and C equal to the reactions at these points due to the loads on 1B and 4C.

$$\text{Let } 1B = a_1; \quad B2 = b_1; \quad 2-3 = l_2; \quad 3C = b_2; \quad C4 = a_2.$$

(1) *A uniform load of intensity w per foot run.*

Taking 1B and 4C as independent girders,

$$R_1 a_1 = \frac{w a_1^2}{2} \quad \therefore R_1 = \frac{w a_1}{2}$$

$$R_4 a_2 = \frac{w a_2^2}{2} \quad \therefore R_4 = \frac{w a_2}{2}$$

R_1 and R_4 are always positive; there can be no lifting force at 1 or 4, consequently no anchorage will be needed at these points.

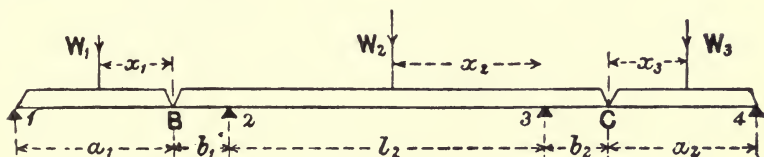

Fig. 88.

Taking BC as an independent girder,

$$\text{Load at } B = w a_1 - R_1 = \frac{w a_1}{2};$$

$$\text{Load at } C = \frac{w a_2}{2}.$$

Taking moments about pier 3,

$$R_2 l_2 = \frac{w a_1}{2} (b_1 + l_2) + w b_1 \left(\frac{b_1}{2} + l_2 \right) + \frac{w l_2^2}{2} - \frac{w b_2^2}{2} - \frac{w a_2}{2} b_2 = 0.$$

If $a_1 = a_2$, and $b_1 = b_2$,

$$R_2 = \frac{w}{2} (a_1 + 2b_1 + l_2).$$

The bending moment at pier 2,

$$M_2 = -\frac{w a_1}{2} b_1 - \frac{w b_1^2}{2}.$$

Bending moment at any section distant x from pier 2,

$$M_x = R_2 x - \frac{w a_1}{2} (b_1 + x) - w b_1 \left(\frac{b_1}{2} + x \right) - \frac{w x^2}{2}.$$

(2) *Concentrated loads.*

A load W_1 on 1B distant x_1 from B.

A load W_2 on the span 2—3 distant x_2 from 3.

A load W_3 on 4C distant x_3 from C.

In this case we get the reactions

$$R_1 = \frac{W_1 x_1}{a_1},$$

$$R_4 = \frac{W_3 x_3}{a_2}.$$

$$\text{Load at } B = W_1 - R_1 = W_1 \left(1 - \frac{x_1}{a_1}\right);$$

$$\text{Load at } C = W_3 - R_4 = W_3 \left(1 - \frac{x_3}{a_2}\right).$$

Taking moments about pier 3,

$$R_2 l_2 = W_1 \left(1 - \frac{x_1}{a_1}\right) (b_1 + l_2) + W_2 x_2 - W_3 \left(1 - \frac{x_3}{a_2}\right) b_2.$$

Taking moments about pier 2,

$$R_3 l_2 = W_3 \left(1 - \frac{x_3}{a_2}\right) (b_2 + l_2) + W_2 (l_2 - x_2) - W_1 \left(1 - \frac{x_1}{a_1}\right) b_1.$$

These equations give R_2 and R_3 .

The bending moments at piers 2 and 3 are

$$M_2 = -W_1 \left(1 - \frac{x_1}{a_1}\right) b_1,$$

$$M_3 = -W_3 \left(1 - \frac{x_3}{a_2}\right) b_2.$$

Here, again, we see that the moments at the piers are determined solely from the loads on the spans containing the hinges.

63. Suspension bridges.

In a suspension bridge the platform is suspended by steel rods from link or wire rope cables, which pass over towers built on piers, and are securely anchored down at the ends.

When a chain of uniform weight per foot of length is suspended and hangs freely it takes the form of a *catenary curve*.

In practice, however, the loads are usually suspended from the cables by rods placed at equal distances apart, and the load is assumed to be uniform per horizontal foot run of span. The curve of the cable or chain is then a *parabola*.

64. Chain uniformly loaded per foot run of span.

Let AOB , Fig. 89, be the chain suspended at A and B .

„ w = uniform load per foot run of span.

„ l = length of span.

„ d = dip or depth of lowest point of curve below horizontal AB .

Take O the lowest point of chain as origin.

Let x, y be the co-ordinates of any point P of the chain.

The portion OP of the chain is kept in equilibrium by :

- (1) The weight wx , acting at R , the middle point of OQ .
- (2) The tension at P , acting tangentially to the chain.
- (3) The horizontal tension H at O .

These three forces must meet in the same point R , and PQR is a triangle of forces.

Therefore

$$\frac{y}{x} = \frac{wx}{H}$$

or

$$y = \frac{wx^2}{2H} \dots \dots \dots (1),$$

which is the equation to a *parabola* with its vertex at O .

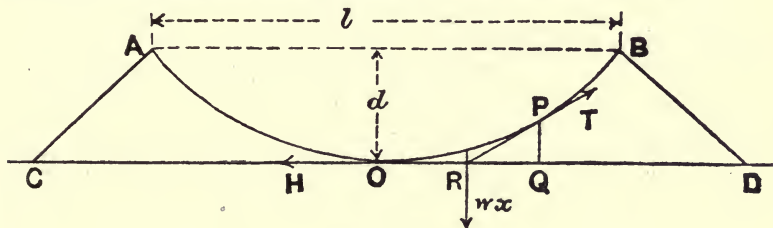

Fig. 89.

From (1)
$$H = \frac{wx^2}{2y} \dots \dots \dots (2).$$

Let T = tension at P , then

$$T^2 = (wx)^2 + H^2 = w^2x^2 + \frac{w^2x^4}{4y^2}.$$

Therefore

$$T = wx \sqrt{1 + \frac{x^2}{4y^2}} \dots \dots \dots (3).$$

This equation gives the tension at any point of the chain.

At the ends A and B , where $x = \frac{l}{2}$; $y = d$: we get from Equations (2) and (3)

$$H = \frac{wl^2}{8d},$$

$$T = \frac{wl}{2} \sqrt{1 + \frac{l^2}{16d^2}} = \frac{wl}{8d} \sqrt{16d^2 + l^2}.$$

The approximate length of cable is

$$l + \frac{8d^2}{3l}.$$

65. Pressure on the piers.

In Fig. 89 AOB is the main chain or cable, AC and BD are the side chains or backstays which are anchored down at C and D . There are two methods of carrying the chain over the piers.

(a) The main chain and backstays may be continuous, and pass over smooth rounded saddles.

(b) The main chain and backstays may be separate, each secured to a saddle free to move horizontally on the top of pier.

Let T_1 = tension on main chain at B .

„ T_2 = tension on backstay at B .

„ a_1 = inclination to the horizontal of main chain at B .

„ a_2 = inclination to the horizontal of backstay at B .

„ R = vertical pressure on pier.

CASE A.—The tensions T_1 and T_2 are practically equal.

Then
$$R = T_1(\sin a_1 + \sin a_2),$$
 and there is a horizontal force
$$= T_1(\cos a_1 - \cos a_2);$$
 if $a_1 = a_2$, then
$$R = 2T_1 \sin a_1,$$
 and there is no horizontal force.

CASE B.—The resultant pressure on pier will always be vertical,

$$R = T_1 \sin a_1 + T_2 \sin a_2.$$

66. Stiffening girder.

When a moving load passes over a suspension bridge the shape of the cables becomes deformed. The object of the stiffening girder is to distribute the load uniformly over the cables, so that they may not be distorted.

Fig. 90 shows a stiffening girder. The booms or chords must be designed to take tension and compression. It may be a single girder extending from tower to tower, or it may consist of two girders hinged at the centre; the latter is the better method as it counteracts the stresses due to changes of temperature.

67. Single girder without central hinge. Uniform live load.

When the live load comes on to the bridge, the stiffening girder distributes the load uniformly to the cable, and if the load is light in comparison with the weight of the cable, the latter will keep its parabolic shape, and thus the stresses in the suspenders will be equal.

In Fig. 90 A and B are the supports, and suppose the bridge loaded over the portion $BC = x$, with a live load of intensity w per lineal foot.

Let l = span.

„ P = pull on each suspender.

„ p = uniform upward pull of the suspenders per lineal foot.

„ R_1 and R_2 be the reactions at B and A respectively, due to the partial load.

Now on the assumption that the weight is transmitted through the suspenders,

$$pl = wx,$$

or
$$p = \frac{wx}{l} \dots\dots\dots(1).$$

Applying the conditions of equilibrium,

$$R_1 + R_2 + pl - wx = 0.$$

$$\therefore R_1 + R_2 = 0.$$

Taking moments round B ,

$$R_2 l + \frac{pl^2}{2} - \frac{wx^2}{2} = 0.$$

Therefore

$$R_2 = -\frac{wx}{2l} (l-x),$$

and

$$R_1 = -R_2 = \frac{wx}{2l} (l-x) \dots\dots\dots(2).$$

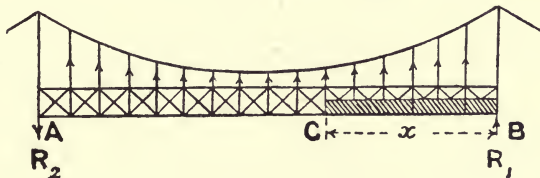

Fig. 90.

The reactions are therefore equal and opposite, and are a maximum when $x = \frac{l}{2}$; their maximum value being $\frac{wl}{8}$. Thus, the maximum shearing force at the supports occurs when the live load covers half the span.

The shearing force at any section in the loaded segment distant x_1 from the right support is

$$F = R_1 + px_1 - wx_1.$$

Substituting for R_1 and p their values from (1) and (2),

$$F = \frac{w(l-x)}{l} \left(\frac{x}{2} - x_1 \right) \dots\dots\dots(3),$$

when

$$x_1 = \frac{x}{2}, \quad F = 0.$$

It can be similarly shown that the shearing force is zero at the middle of the unloaded segment.

Again, from (3) we see when

$$x_1 = x, \quad F = -R_1.$$

Thus, the magnitude of the shearing force at the head of the live load is equal to that of either reaction, and the absolute maximum shearing force equal to $\frac{wl}{8}$ occurs when the live load covers half the span.

Bending moment.—The bending moment at any section of the loaded segment distant x_1 from the right support is

$$\begin{aligned} M &= R_1 x_1 + \frac{p x_1^2}{2} - \frac{w x_1^2}{2} \\ &= \frac{w(l-x)}{2l} (x x_1 - x_1^2) \dots \dots \dots (4). \end{aligned}$$

From (4) we see that

$$M = 0, \text{ when } x_1 = 0 \text{ and when } x_1 = x.$$

M is a max. when $x_1 = \frac{x}{2}$, that is, where $F = 0$,

$$\text{Max. } M = \frac{w(l-x)}{8l} x^2.$$

To find the absolute maximum as the load advances, equate

$$\frac{d}{dx} (lx^2 - x')$$

to zero, which gives $x = \frac{2}{3}l$.

Therefore absolute maximum bending moment

$$= \frac{wl^2}{54},$$

and occurs when the live load covers two-thirds of the span.

Similarly by considering the unloaded segment, the maximum bending moment occurs also at its middle section, its absolute maximum value being

$$= -\frac{wl^2}{54},$$

and occurs when the live load covers one-third of the span.

68. Stiffening girder hinged at the centre.

The hinge at centre provides for contraction and expansion, and thus counteracts the stresses due to changes of temperature. As in the last case the cable is assumed to remain parabolic in

shape, with its vertex at the middle when the span is partially loaded, and consequently all the suspenders are subject to an equal stress. Again, owing to the hinge, there is no bending moment at the middle.

Taking the same notation as in the last case, let R_1 and R_2 be the reactions at the right and left supports; w the intensity of the live load; and p the uniform upward pull of the suspenders.

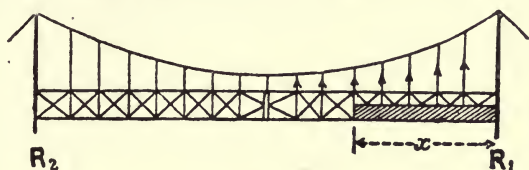

Fig. 91.

Let the live load, as in Fig. 91, cover a portion x of the right half span.

Then for equilibrium, we have

$$R_1 + R_2 + pl - wx = 0,$$

and taking moments about the hinge,

$$R_1 \frac{l}{2} + p \frac{l^2}{8} - \frac{wx}{2} (l-x) = 0,$$

$$R_2 \frac{l}{2} + \frac{pl^2}{8} = 0.$$

From these three equations we get

$$p = \frac{2wx^2}{l^2},$$

$$R_1 = \frac{w}{2l} (2xl - 3x^2),$$

$$R_2 = -\frac{w}{2l} x^2.$$

R_1 is a maximum when $x = \frac{l}{3}$; and max. $R_1 = \frac{wl}{6}$.

R_2 is a maximum when $x = \frac{l}{2}$; and max. $R_2 = -\frac{wl}{8}$.

The shearing force at the front of load

$$\begin{aligned} F &= R_1 + px - wx \\ &= \frac{w}{2l^2} (4x^3 - 3x^2l). \end{aligned}$$

This is a maximum when $x = \frac{l}{2}$, and is equal to $\frac{wl}{8}$.

Maximum bending moments.

The maximum bending moment occurs at the section where $F = 0$.

At any section of the loaded segment distant x_1 from the right support

$$F = R_1 + px_1 - wx_1 \dots\dots\dots(1),$$

$$M = R_1x_1 + \frac{px_1^2}{2} - \frac{wx_1^2}{2} \dots\dots\dots(2).$$

If $F = 0$, then from (1)

$$x_1 = \frac{R_1}{w-p} = \frac{(2xl - 3x^2)l}{2(l^2 - 2x^2)},$$

and

$$M = \frac{1}{2} \frac{R_1^2}{w-p} = \frac{w(2xl - 3x^2)^2}{8(l^2 - 2x^2)} \dots\dots\dots(3).$$

For *max. M*, differentiating and equating to zero, we get

$$(l^2 - 2x^2)(l - 3x) + x^2(2l - 3x) = 0,$$

or

$$3x^3 - 3l^2x + l^3 = 0;$$

$$x = 0.4l$$

is an approximate solution.

Substituting in (3),

$$\text{Max. positive } M = \frac{wl^2}{53} \text{ (app.)}$$

For the left-hand half of the span, at a section distant x_2 from the left support,

$$F = R_2 + px_2 = -\frac{wx^2}{2l} + \frac{2wx^2}{l^2}x^2 \dots\dots\dots(4),$$

$$M = R_2x_2 + \frac{px_2^2}{2} \dots\dots\dots(5).$$

From (4) we see, when $F = 0$, $x_2 = \frac{l}{4}$,

and

$$M = -\frac{wx^2}{16}.$$

Therefore, max. negative bending moment = $-\frac{wl^2}{64}$.

69. Maximum bending moments due to a single live load.

To find the positions of the load for maximum bending moments in a stiffening girder jointed at the centre.

The pull in the hangers is uniform, and the bending moment

diagram is a parabola $AFLB$ with central ordinate $\frac{pl^2}{8}$, if p is the uniform pull per unit of length.

The bending moment diagram for the load is a triangle.

The bending moment on stiffening girder at any section is the difference of the lengths of the ordinates of triangle and parabola at the section.

Maximum positive bending moment for a given position of load = DC. Hence, we have to find for what position of load DC is a maximum.

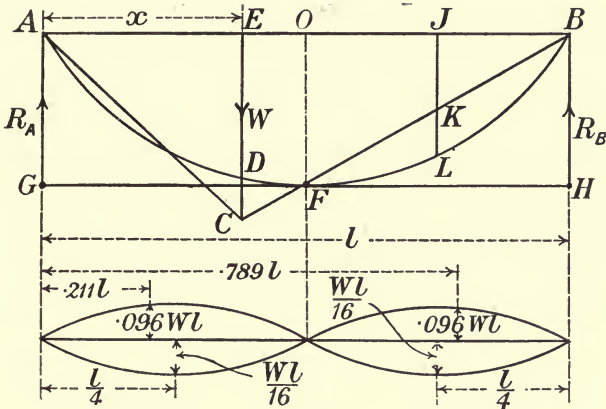

Fig. 92.

Let x be the distance of load W from A .

$$\text{Now } EC = R_A x = \frac{W(l-x)x}{l}; \quad ED = \frac{px(l-x)}{2},$$

$$\text{and } OF = EC \frac{l}{2(l-x)} = \frac{Wl(l-x)x}{2l(l-x)} = \frac{Wx}{2},$$

$$\therefore \frac{pl^2}{8} = \frac{Wx}{2}, \text{ or } p = W \frac{4x}{l^2}.$$

$$\text{Hence, } DC = EC - ED = \frac{Wx(l-x)}{l} \left(1 - \frac{2x}{l}\right)$$

$$= \frac{Wx(l-x)(l-2x)}{l^2}$$

$$= \frac{W}{l^2} (2x^3 - 3x^2l + xl^2) \dots \dots \dots (1),$$

$$\text{and } \frac{dDC}{dx} = \frac{W}{l^2} (6x^2 - 6xl + l^2) = 0 \text{ for max.}$$

$$\therefore x = \frac{3 \pm \sqrt{3}}{6} l,$$

$$x = 0.789l \text{ or } 0.211l,$$

and from (1) Max. $M = 0.096 Wl$.

Maximum negative bending moment is evidently when the load W is at the centre of span, and the value of this maximum negative bending moment is KL ; the vertical intercept at $x = \frac{3}{4}l$, i.e. half way between central hinge and support B .

In this case, with load at centre,

$$\frac{pl^2}{8} = \frac{Wl}{4}, \text{ or } p = \frac{2W}{l}.$$

$$\begin{aligned} \text{Hence, } KL &= JL - JK = \frac{pl}{4} \cdot \frac{3}{4}l - \frac{1}{2} \frac{Wl}{4} \\ &= \frac{Wl}{8} \left(\frac{3}{2} - 1 \right) \\ &= \frac{Wl}{16}. \end{aligned}$$

The bending moment diagram is shown in Fig. 92.

CHAPTER XI.

DESIGN OF RIVETED JOINTS.

70. Definitions. Lap and butt joints.

In a *lap joint* one plate overlaps the other, and they are connected by one or more rows of rivets.

In a *butt joint* the plates are kept in the same plane, and the joint is covered on one or both sides by a *cover plate*, which is riveted to the plates.

The lap joint is objectionable, owing to the straining forces on the two plates not being in the same line, thus forming a couple, which weakens the joint by bending (Fig. 95).

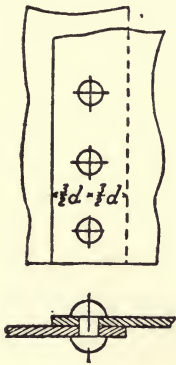

Fig. 93.

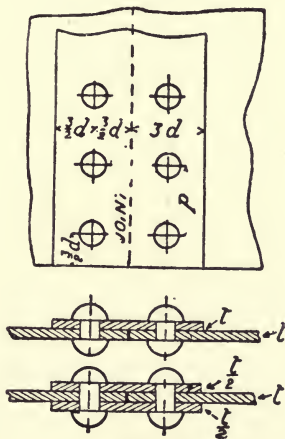

Fig. 94.



Fig. 95.

The butt joint is the one generally used, and is the more effective joint, owing to its symmetry and the absence of eccentric stresses.

Single riveting is when there is only one line of rivets in a lap joint, or one line on *each* side of the joint in a butt joint.

Double riveting, when there are two lines of rivets in the lap, or two lines on *each* side of the joint in a butt joint.

Fig. 93 shows a single-riveted lap joint; Fig. 94 a single-riveted butt joint; Figs. 96 to 99 show double-riveted lap and butt joints.

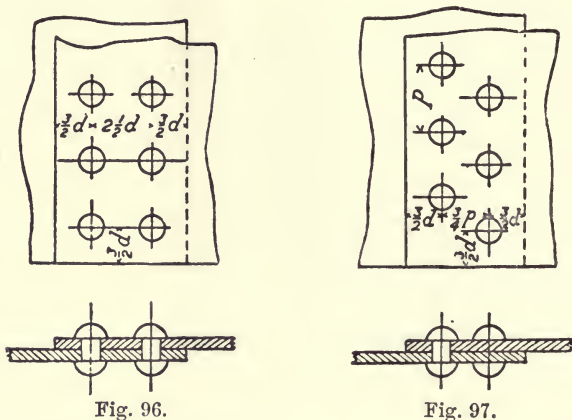

In *chain riveting* the rivets in the several rows are opposite to one another (Figs. 96 and 98).

In *zig-zag riveting* the rivets in one row alternate with the spaces in next row (Figs. 97 and 99).

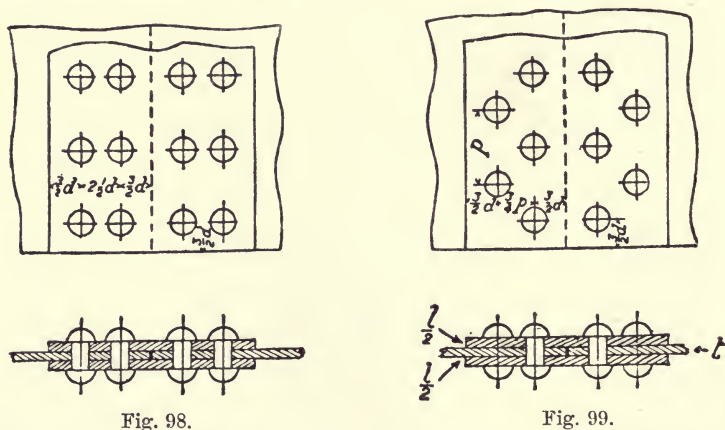

The *pitch* is the distance from centre to centre of the rivets in one row.

The *lap* is the distance at right angles to the joint, between the

edges of two overlapping plates; or, in the case of a butt joint, the distance between the joint and the end of the cover plate.

A rivet is in *single shear* when shearing can take place only on *one* cross section of the rivet, as in lap joints and in butt joints with one cover plate (Figs. 93 and 94).

A rivet is in *double shear* when shearing can take place on two cross sections, as in butt joints with two cover plates.

71. Rules to be observed in designing joints.

Diameter of rivets for given plates.

Let t = thickness of plate in inches.

„ d = diameter of rivet in inches.

The following rule is sometimes used: $d = 2t$ for plates under $\frac{1}{2}$ " ; $d = 1\frac{1}{2}t$ for plates of $\frac{1}{2}$ " and over.

Professor Unwin gives the simple rule which should be adopted :

$$d = 1.2 \sqrt{t}.$$

In girder work the rivets ought, if possible, to be of one size throughout, or at most two sizes. In structural ironwork of this class rivets $\frac{3}{4}$ " and $\frac{7}{8}$ " are most generally used. Field rivets, which have to be riveted up by hand when the girder is in position, should never exceed $\frac{3}{4}$ " diameter, on account of the difficulty of driving tight rivets of larger size by hand.

Minimum pitch.—The pitch of the rivets, as will be seen presently, is found by equating the shearing strength of the rivets to the tensile strength of the net area of the plate, but the distance between the edges of the rivet holes should *never be less than* the diameter of the rivet. This gives the *minimum pitch* = $2d$.

In boiler-work the pitch of the rivets is necessarily close, but in *girder-work* the pitch is practically *never less than* three diameters.

A maximum pitch of 6" should not be exceeded, as it is advisable to keep the plates close to prevent the entrance of water.

The distance from the centre of rivet hole to the edge of a plate should not be *less than* $1\frac{1}{2}d$. This leaves a clear diameter of rivet between the edge of hole and edge of plate. This minimum distance is, in practice, increased to $1\frac{1}{2}d + \frac{1}{16}$, and in girder-work is usually $2d$. It should be noted that the diameter of the hole is $\frac{1}{16}$ of an inch larger than the diameter of the rivet, to allow the latter to enter when hot.

The *grip* of a rivet—that is, the distance between its heads—is the thickness of the plates to be joined by it, *plus* $\frac{1}{2}$ of an inch for each joint between the plates to allow for uneven surfaces,

which prevents very close contact. The maximum grip of a rivet should not exceed *four times the diameter of the rivet*.

72. Strength of riveted joints.

Take, for simplicity, the case of a single-riveted lap joint. Consider a strip of such a joint of width equal to the pitch (Fig. 100). As each rivet supports such a strip, the results obtained applied to the joint as a whole.

- Let p = pitch of rivets.
- „ d = diameter of rivet.
- „ t = thickness of plates.
- „ l = distance from centre of rivet to edge of plate.
- „ f_t = tensile resistance of plates.
- „ f_s = shearing resistance of rivets.
- „ f_c = crushing resistance.
- „ T = resistance of a strip of the joint of width p .

Such a joint, if in tension, may fail in four ways :

- (1) The rivet may shear (Fig. 101). The area resisting shear

$$= \frac{\pi d^2}{4}.$$

The resistance to shear is

$$T = f_s \frac{\pi d^2}{4} \dots\dots\dots(1).$$

- (2) The plate may tear along the line of minimum section (Fig. 102). The area of either plate on this line is $(p - d) t$. The resistance to tension is

$$T = f_t (p - d) t \dots\dots\dots(2).$$

- (3) The plate and rivet may be crushed (Fig. 103), and this will render the joint loose. The area of plate or rivet supporting the pressure = dt ; this area is called the *bearing area*, and the pressure upon it the *bearing pressure*. The resistance to crushing is

$$T = f_c dt \dots\dots\dots(3).$$

- (4) The plate may break in front of the rivet (Fig. 104). The portion of plate in front of the rivet may be considered as a beam of length d , and depth = $\frac{1}{2}(l - d)$. Suppose the pull T to be replaced by two parts $\frac{T}{2}$ each acting half way between the centre and edge of the rivet.

This gives a bending moment of $\frac{Td}{8}$, and equating this to the moment of resistance

$$\frac{Td}{8} = f_t Z = \frac{f_t t \left(l - \frac{d}{2} \right)^2}{6};$$

or
$$T = f_t t \frac{(2l-d)^2}{3d} \dots\dots\dots(4).$$

Fig. 100.

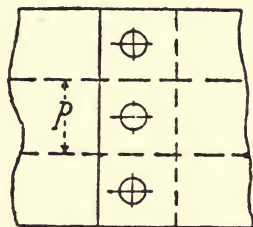

Fig. 101.

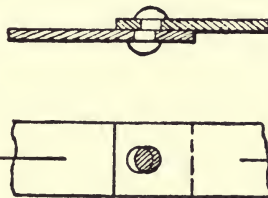

Fig. 102.



Fig. 103.



Fig. 104.



The resistances to shearing, tearing, crushing, or breaking should be equal.

When the rivets are in double shear Equation (1) becomes

$$T = f_s \frac{\pi d^2}{2}.$$

73. Resistance of multiple riveted joints.

When there are more than two rows of rivets parallel to the joint in each plate it is called *multiple riveted*.

Let T = total longitudinal force, transmitted through the joint.

„ n = number of rivets required in each plate joined—that is, the total number through the joint if a lap joint, or the number on each side of the joint in a butt joint.

Then, assuming that T is *uniformly distributed among the n rivets*, n must be such that

$$T = \begin{cases} nf_s \frac{\pi d^2}{4} & \text{for rivets in single shear ;} \\ nf_s \frac{\pi d^2}{2} & \text{for rivets in double shear ;} \end{cases}$$

and $T = n f_c d t$; for crushing

also if b = breadth of plate,

m = number of rivets in one transverse row,

the tensile resistance of the net section of the plate is $f_t (b - m d) t$, and it is necessary that the number m , and the dimensions b , t , should be such that $T = f_t (b - m d) t$.

74. Tensile shearing and crushing strength of plates and rivets in riveted joints.

Tensile strength of iron and steel plates (unperforated) f_t .

Wrought iron, 18 to 22 tons per sq. in.

Steel, 28 to 32 „ „ „

Shearing strength f_s is approximately $\frac{4}{5} f_t$.

Crushing strength f_c is approximately $2 f_s$.

Safe working stresses for steel.

$$f_t = 7 \text{ to } 8 \text{ tons per sq. in.}$$

$$f_s = 5 \text{ to } 6 \text{ „ „ „}$$

$$f_c = 10 \text{ to } 12 \text{ „ „ „}$$

75. CASE I.—SINGLE-RIVETED LAP JOINT. SINGLE-RIVETED BUTT JOINT WITH ONE COVER (Figs. 93 and 94).

In both these cases the rivets are in single shear.

Diameter of rivet: $d = 1.2 \sqrt{t}$,

where t = thickness of plate.

Pitch.—Equate the tearing resistance to the shearing resistance:

$$(p - d) t f_t = \frac{\pi d^2}{4} f_s = 0.785 d^2 f_s.$$

$$p = 0.785 \frac{d^2}{t} \cdot \frac{f_s}{f_t} + d.$$

The lap must be at least 3 times the diameter of the rivet.

CASE II. DOUBLE-RIVETED LAP JOINT (Figs. 96 and 97).
DOUBLE-RIVETED BUTT JOINT WITH SINGLE COVER.

Since there are two rivets to each strip of width equal to the pitch,

$$T = \frac{\pi d^2}{2} f_s.$$

$$T = 2f_c dt.$$

Diameter : $d = 1.2\sqrt{t}.$

Pitch.—Equating tearing and shearing resistances :

$$(p - d)tf_t = \frac{\pi d^2}{2} f_s.$$

$$p = 1.57 \frac{d^2}{t} \frac{f_s}{f_t} + d.$$

In *chain-riveted* joints the distance between pitch lines (centre lines of each row of rivets) should be $2\frac{1}{2}$ to 3 diameters, and the lap should therefore be $5\frac{1}{2}$ to 6 diameters.

In *zig-zag-riveted* joints (Figs. 97 and 99) the distance between the pitch lines is usually $\frac{3}{4}$ pitch, so that lap should be

$$3 \text{ to } 4 \text{ diameters} + \frac{3}{4} \text{ pitch.}$$

CASE III.—SINGLE-RIVETED BUTT JOINT WITH TWO COVERS (Fig. 94).

The rivets are in double shear, and the shearing resistance

$$= \frac{\pi d^2}{2} f_s.$$

Crushing resistance $= f_c dt.$

Diameter : $d = 1.2\sqrt{t}.$

Pitch.—To determine the pitch the tearing resistance must be equated to the shearing resistance or crushing resistance which ever is *least*—in this case probably the crushing resistance :

$$(p - d)tf_t = f_c dt.$$

CASE IV.—DOUBLE-RIVETED BUTT JOINT WITH TWO COVERS (Figs. 98 and 99).

With this joint there are two rows of rivets in double shear, and

$$T = f_s \pi d^2.$$

$$T = 2f_c dt.$$

Diameter : $d = 1.2\sqrt{t}.$

Pitch.—The shearing and crushing resistances must first be calculated, and the tearing resistance equated to the *least* of these.

Lap.—In chain-riveted joints distance between pitch lines $2\frac{1}{2}$ to 3 diameters.

Lap = 6 diameters.

Zig-zag-riveted joints. Distance between pitch lines = $\frac{3}{4}$ pitch.

Lap = 3 to 4 diameters + $\frac{3}{4}$ pitch.

76. Thickness of cover plates.

The thickness of the cover plates must be such that the strength of their *net section* is at least equal to that of the net section of the plates to be joined.

If T is the stress, b the breadth of plate, m the number of rivets in transverse row nearest joint,

t_1 = thickness of each cover plate,

$$2t_1(b - m_1d)f_t \geq T,$$

or

$$t_1 \geq \frac{T}{2(b - m_1d)f}$$

The usual proportions are :

With one cover plate, thickness = $1\frac{1}{8}$ of the plate thickness.

With two cover plates, thickness of each = $\frac{5}{8}$ of the plate thickness.

77. Efficiency of riveted joints.

The efficiency of a joint is the ratio of the strength of the joint to the strength of an equal width of the solid plate.

Taking as before a strip of the joint of width equal to the pitch p , we get the different efficiencies as follows:—

Double-riveted lap joint. (See Case II., Art. 75).

For plate in tension. Efficiency = $\frac{(p-d)f_t}{ptf_t} = \frac{p-d}{p}$.

For rivet in shear. Efficiency = $\frac{2\pi d^2 f_s}{4ptf_t}$.

For rivet in compression. Efficiency = $\frac{2f_c dt}{ptf_t} = \frac{2f_c d}{pf_t}$.

The efficiency is the smallest of these values.

Generally, the efficiency for rivet in shear = $\frac{N\pi d^2 f_s}{4ptf_t}$, where N is the number of rivets in a pitch length.

Double-riveted butt joint with two covers. (See Case IV., Art. 75).

For tension of the plate, Efficiency = $\frac{(p-d)}{p}$.

For shear of rivet, Efficiency = $\frac{\pi d^2 f}{p t f_t}$.

For compression of rivet, Efficiency = $\frac{2 f_c d}{p f_t}$.

78. Group-riveted joints.

Joints are sometimes made by a group of rivets, so arranged that as little as possible of the original resistance of the unperforated plate is lost at the joint. The arrangement of the rivets is called *group riveting*.

In order to get the stress uniformly distributed over the plate the centre of gravity of the group of rivets must lie on the axis of the piece, the axis being the line joining the centres of gravity

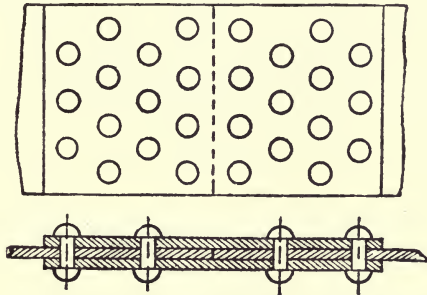

Fig. 105.

of the cross sections. When two plates not in line are to be riveted, as in the bracing and the flange of a girder, the centre of gravity of the group ought to lie on the intersection of the axes of the two plates.

79. Group-riveted joint of greatest economy.

In an ordinary group-riveted joint (Fig. 105) the net section of the plate is its gross section diminished by all the rivet holes in the transverse row nearest to the end of the cover plate. By adopting the form shown in Fig. 106 the loss of section may be reduced to that due to one rivet hole only.

Consider, for example, a joint for which calculation gives $n = 6$ rivets required on each side of joint.

A single rivet is placed in the line *aa* on the axis of the plate, diminishing the section by one rivet hole, and on the net section

we have the whole stress T . Now, assuming that the stress T is equally distributed between the 6 rivets in the group the leading rivet transmits $\frac{T}{6}$ to the cover plates, so that the stress on the net section at bb is $\frac{5}{6}T$. A second rivet may, therefore, be placed at bb without diminishing the resistance of the joint. At section cc the stress is $\frac{1}{2}T$, so that one more rivet may be placed at that section.

At cc the stress in the cover plates will be equal to T .

The distances ab, bc are usually $\frac{3}{4}$ of the transverse pitch.

The strength of the joint is approximately equal at all the sections and may be taken as

$$(b-d) f_t . t.$$

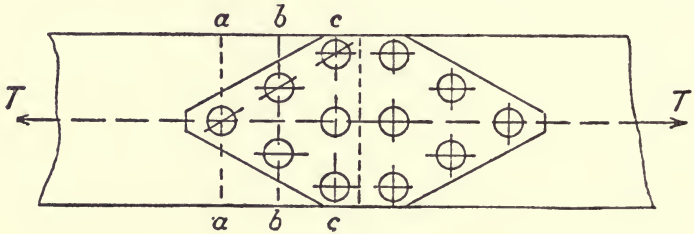

Fig. 106.

The thickness of the cover plates must be such that the resistance of their net section at the transverse row of rivets cc nearest to the joint is at least equal to the stress T .

Let t_1 = required thickness of each cover plate ;

„ m_1 = number of rivets in row cc ; then

$$2t_1(b-m_1d) \cdot f_t \geq T,$$

or

$$t_1 \geq \frac{T}{2(b-m_1d)f_t}$$

The width of the cover plates is tapered uniformly as in Fig. 106.

EXAMPLE.

Determine the dimensions of a zig-zag double-riveted butt joint with one cover for jointing two boiler plates $\frac{3}{8}$ inch thick (Fig. 105).

Take $f_t = 8$ tons per sq. in.

$f_s = 6$ „ „ „

$f_c = 12$ „ „ „

There are two rivets in each strip of a width equal to the pitch.

Diameter : $d = 1.2\sqrt{t} = \frac{3}{8}$ inch.

As the rivet holes are about $\frac{1}{16}$ inch larger than the diameter of rivet, the value of d is for calculation taken $\frac{1}{16}$ inch greater than diameter of rivet.

Hence d for calculation = $\frac{13}{16}$ inch.

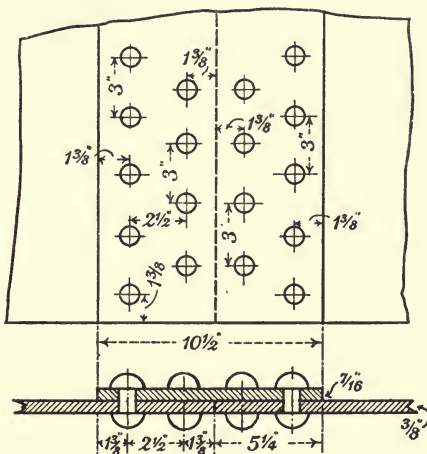

Fig. 107.

Pitch.

$$\begin{aligned} \text{Shearing resistance} &= 2 \frac{\pi d^2}{4} f_s = 1.04 \times 6 \\ &= 6.24. \end{aligned}$$

$$\begin{aligned} \text{Crushing resistance} &= 2 f_c d t = \frac{2 \times 12 \times 13 \times 3}{16 \times 8} \\ &= 7.3. \end{aligned}$$

Equate the tearing resistance to the shearing resistance which is least,

$$\begin{aligned} (p-d)t f_t &= 6.24 \\ p &= \frac{8.68}{3} = 2.89 \\ &= 3 \text{ inches, say.} \end{aligned}$$

Lap, or distance from joint to edge of cover plate,

$$\begin{aligned} l &= \frac{1}{4}d + \frac{3}{4}p + \frac{1}{4}d \\ &= \frac{1}{8} + 2\frac{1}{2} + \frac{1}{8} = 5\frac{1}{4} \text{ inches.} \end{aligned}$$

Cover plate.

$$\begin{aligned} \text{Width} &= 2l = 10\frac{1}{2} \text{ inches.} \\ \text{Thickness} &= \frac{1}{8}t = \frac{7}{16} \text{ inch.} \end{aligned}$$

Efficiency.

For tension of the plate $= \frac{p-d}{p} = 0.73$, or 73 per cent.

For shear of rivets $= \frac{\frac{p}{\pi d^2} f_s}{p t f_t} = \frac{62.4}{9} = 0.7$ or 70 per cent.

80. Joints for two or more plates.

When several plates have to be riveted together their joints are arranged in consecutive steps as in Fig. 108; so that one pair of cover plates is sufficient for the whole series of joints. The



Fig. 108.

number of rivets between any two consecutive joints must be determined from the stress. An example is worked out in Art. 81, Fig. 113.

81. Example of various riveted joints in a girder design.

At a panel point in the upper chord of a Pratt truss (Fig. 109) the following calculations and figures give the number of rivets required and their distribution for:

- (a) Connexion of inclined brace to gusset plate.
- (b) Connexion of vertical post to gusset plate and upper chord.
- (c) Connexion of gusset plate to upper chord and vertical.
- (d) Joint in top plate, side plates, and angles of upper chord.

The cross section of upper chord is shown in Fig. 111, and the section of vertical in Fig. 110. The elevation showing connexion of brace and vertical to upper chord is shown in Fig. 109.

The gusset plates, to which the inclined braces are attached, come inside the side plates of chord; the vertical post fits in between the gusset plates, and goes close up to the underside of the top plate of chord.

In the case of '*field rivets*'—that is, rivets put in on the work during erection—an addition of 10 per cent. is usually made to the calculated number of rivets required, as they may not be so securely driven as the shop rivets.

- (a) CONNEXION OF INCLINED BRACE TO GUSSET PLATE (Fig. 109).

The inclined brace consists of *two* plates $16'' \times \frac{1}{2}''$, one fastened to each gusset plate.

Total tensile stress in inclined brace = 140 tons.
 Therefore tensile stress in *each* plate of brace = 70 tons.
 Diameter of rivets $\frac{7}{8}$ inch. Area = 0.6 sq. in.
 Working stresses.—Shear 6 tons per sq. in.
 Bearing 12 tons per sq. in.

Let N = number of rivets required to connect tie plate to gusset plate.

Two cover plates should be used at the joint.
 First compare the bearing and shear strengths.

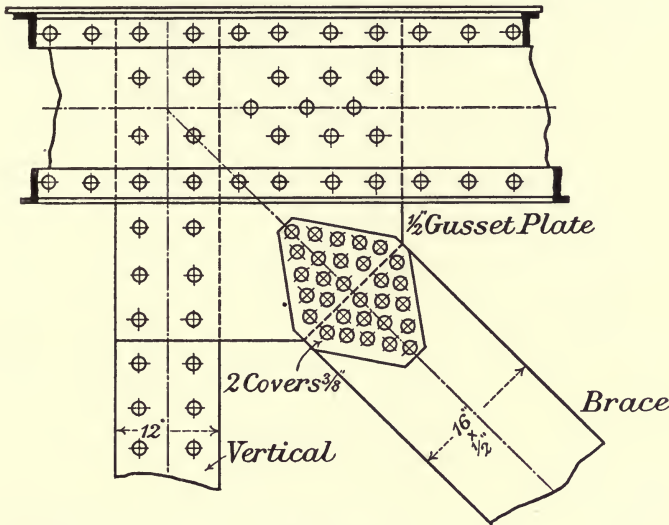

Fig. 109.

Bearing strength of one $\frac{7}{8}$ inch rivet in $\frac{1}{2}$ inch plate
 $= \frac{7}{8} \times \frac{1}{2} \times 12 = 5.25$ tons.

Shear strength of $\frac{7}{8}$ inch rivet in *double* shear
 $= 2 \times 0.6 \times 6 = 7.2$ tons.

The bearing strength being *least* must be used.
 Therefore number of rivets required :

$$N = \frac{70}{5.25} = 13.4,$$

adding 10 per cent. for field rivets. Total number = 15.

Thus 15 rivets are required on *each* side of the joint between gusset plate and brace plate, arranged as in Fig. 109, so that the strength of the plate is weakened only by one rivet hole.

The width of brace is 16 inches, so that with 5 rivets in the

row nearest joint, we get 2 inches between each of the outer rivets and the edge of plate, and a 3-inch pitch.

The distance from joint to nearest row of rivets 2 inches, and the distance between each row of rivets $2\frac{1}{2}$ inches.

Cover plates.

Each cover plate is weakened by 5 rivet holes.

The plate is weakened by one rivet hole.

The joint strength of the covers should be at least equal to the strength of the plate.

Hence, if t = thickness of one cover plate

$$2t(16 - 5 \times \frac{7}{8}) = (16 - \frac{7}{8})\frac{1}{2},$$

$$t = \frac{121}{372} = 0.33$$

$$= \frac{3}{8} \text{ inch (say).}$$

(b) CONNEXION OF VERTICAL POST TO GUSSET PLATES AND SIDE PLATES TOP CHORD (Fig. 109).

The cross section of vertical is shown in Fig. 110.

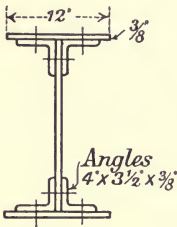

Fig. 110.

The total compressive stress in vertical = 90 tons.

The rivets are in single shear.

Shear strength of one $\frac{7}{8}$ " rivet = $0.6 \times 6 = 3.6$ tons.

Therefore number of rivets required

$$= \frac{90}{3.6} = 25;$$

as these are *field rivets*, add 10 per cent.

Total number required = 28.

As the vertical is riveted on 2 sides to the gusset plate and side plate of chord, the number of rivets on each side of the vertical

$$= \frac{28}{2} = 14.$$

See Fig. 109.

(c) CONNEXION OF GUSSET PLATES TO UPPER CHORD AND VERTICALS.

Considering the equilibrium of the gusset plates, there ought to be as many rivet *sections* connecting it to the vertical and chord as there are rivet sections joining the brace to the gusset plate.

Thus, $2 \times 15 = 30$ rivets are required.
31 rivets are shown in Fig. 109.

(d) DESIGN OF JOINTS IN TOP PLATE AND SIDE PLATES OF CHORD (Figs. 112 and 113).

The total stress in chord member = 400 tons.

The cross section of chord is shown in Fig. 111.

Top plate.—If we use a single cover plate for the joint in top plate, the rivets are in single shear, and the shear strength of one rivet

$$= 0.6 \times 6 = 3.6 \text{ tons.}$$

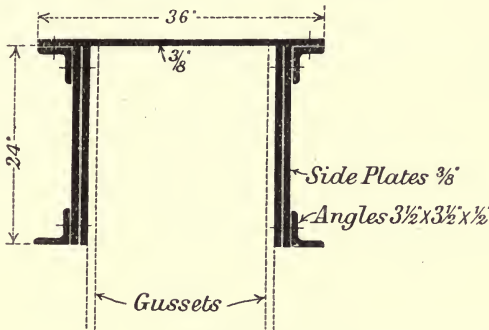

Fig. 111.

The sectional area of chord is

$$\begin{aligned} \text{Top plate } 36 \times \frac{3}{8} &= 13.5 \text{ sq. in.} \\ 4 \text{ side plates } 24 \times \frac{3}{8} &= 36.0 \text{ ,,} \\ 4 \text{ angles } 3\frac{1}{2} \times 3\frac{1}{2} \times \frac{1}{2} &= 13.0 \text{ ,,} \\ \text{Total area} &= \underline{\underline{62.5}} \text{ ,,} \end{aligned}$$

Then, assuming the total stress to be distributed in each plate in proportion to its area,

Stress transmitted by top plate is

$$\frac{13.5}{62.5} 400 = 86.4 \text{ tons.}$$

Let N = number of rivets required on *each* side of the joint, then

$$N = \frac{86.4}{3.6} = 24 + 10 \text{ per cent.} = 26 \text{ (Fig. 112.)}$$

If two cover plates had been used, then, the rivets being in double shear, we must first compare the bearing and shearing strength.

$$\begin{aligned} \text{Bearing strength of } \frac{7}{8} \text{ rivet in } \frac{3}{8} \text{ plate} \\ = 12 \times \frac{7}{8} \times \frac{3}{8} &= 3.93. \end{aligned}$$

$$\begin{aligned} \text{Shear strength (double shear)} \\ = 2 \times 0.6 \times 6 &= 7.2 \text{ tons.} \end{aligned}$$

Since bearing strength is *least*, number of rivets required would have been

$$N = \frac{86.4}{3.93} = 22 + 10 \text{ per cent.} = 24.$$

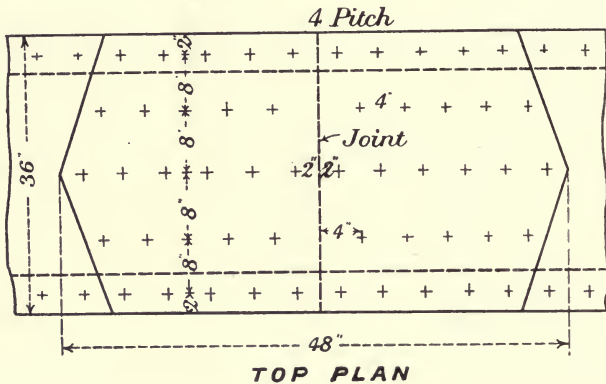

Fig. 112.

Side plates.—Grouped joints with two covers (Fig. 113).
Stress transmitted by one side plate

$$\begin{aligned} & \frac{36}{4} \cdot 400 = \frac{9}{62.5} \cdot 400. \\ & = 57.6 \text{ tons.} \end{aligned}$$

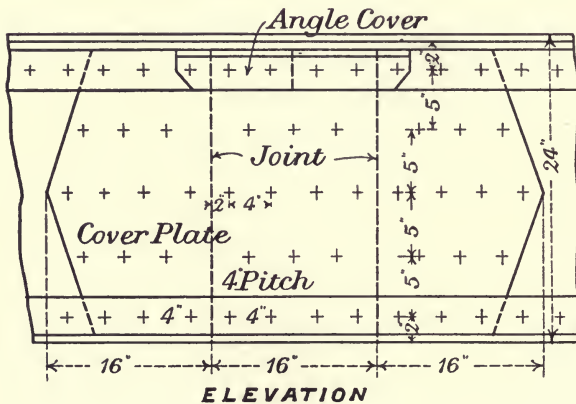

Fig. 113.

Let N = number of rivets required between each joint, and between outside joints and end of cover plates.

Then, since the rivets are in double shear, and the plates are $\frac{3}{8}$ inch thick, we have as before the bearing strength 3.93 tons less than the shear strength 7.2 tons.

Therefore
$$N = \frac{57.6}{3.93} = 14.6 + 10 \text{ per cent.} = 16.$$

In Fig. 113, 18 rivets have been used between the joints for symmetry, and in order not to alter the general pitch of 4 inches.

Angles.

The angles should be spliced by means of an angle splice about $3'' \times 3'' \times \frac{5}{8}''$.

Stress transmitted by *one* angle

$$\begin{aligned} & \frac{13}{4} \\ &= \frac{13}{62.5} \cdot 400 = 20.8 \text{ tons.} \end{aligned}$$

Number of rivets required on each side of joint of angles

$$= \frac{20.8}{3.6} = 6 \text{ nearly.}$$

That is, 3 on the vertical limb and 3 on the horizontal limb of angle.

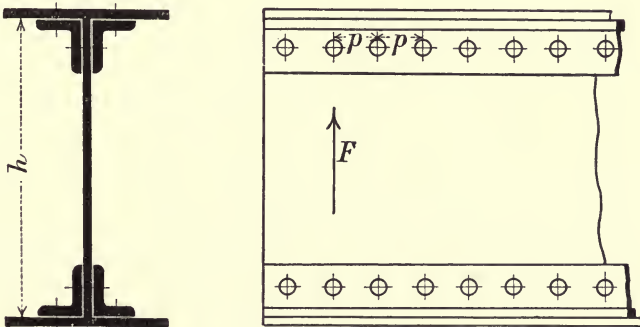

Fig. 114.

82. Plate girder. Riveting of web to flanges.

Fig. 114 gives cross section and elevation of plate girder, showing flanges and web connected by angle irons riveted to them.

To find the pitch of the rivets.

If two vertical sections of the girder are taken at a distance x apart, the total shear on the length x must be equal to the

difference of the normal stresses in the flange at these two sections,

$$= H_1 - H_2 = \frac{M_1 - M_2}{h},$$

and this increment of flange stress must be transmitted by the rivets.

Let N = number of rivets in one foot of length,

„ R = least resistance of one rivet.

„ h = depth of girder.

Then
$$NRx = \frac{M_1 - M_2}{h} \dots\dots\dots(1),$$

or
$$NRh = \frac{M_1 - M_2}{x};$$

but the rate of increase of bending moment $\frac{dM}{dx} = F$

where F is the shearing force.

Hence,
$$NR = \frac{F}{h},$$

or
$$N = \frac{F}{Rh} \dots\dots\dots(2).$$

If p = pitch in inches, then $N = \frac{12}{p}$,

Hence, from (2)

$$\frac{12}{p} = \frac{F}{Rh},$$

that is,
$$\left. \begin{aligned} Fp &= 12Rh, \text{ where } h \text{ is in feet} \\ \text{or, } Fp &= Rh, \text{ where } h \text{ is in inches} \end{aligned} \right\} \dots\dots\dots(3).$$

If p comes out too small, that is, less than three times the diameter of rivet—the web plate must be thickened, or larger angles must be used to take two rows of rivets.

The number of rivets in a short length of x feet can be found if desired, from Equation (1), where M_1 and M_2 are foot tons, h feet and R tons.

EXAMPLES.

1. A girder 30 feet long, 2 feet 3 inches deep, is loaded with a uniform load of 2 tons per foot run. Thickness of web $\frac{1}{2}$ inch. If the rivets are $\frac{3}{4}$ inch diameter, find the pitch of the rivets connecting angles to web near the supported ends.

Assume working stresses :

Shear 6 tons per sq. in.

Bearing 12 tons per sq. in.

Shearing force, F , at ends = $\frac{30 \times 2}{2} = 30$ tons.

As there are two angles, each rivet connecting web to angles is in double shear, and it is first necessary to determine which is *least*, the bearing strength or shearing strength.

Shear strength of one rivet (double shear) = $2 \times 0.44 \times 6 = 5.28$ tons.

Bearing strength of rivet on web plate = $\frac{3}{4} \times \frac{1}{2} \times 12 = 4.5$ tons.

The bearing strength being least must be used in calculation for R .

From (3)

$$p = \frac{Rh}{F} = \frac{4.5 \times 27}{30} = 4.05.$$

Pitch = 4 inches.

2. A cross girder for a bridge carrying two lines of rails is 27 feet long and 24 inches deep; it carries four concentrated loads, each weighing 30 tons; the two loads on one side of the centre of span being symmetrical with the two on the other side. Determine the pitch of the angle rivets if the diameter of rivet is $\frac{7}{8}$ inch.

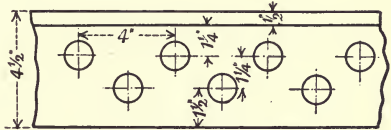

Fig. 115.

Thickness of web = $\frac{1}{2}$ inch.

Assume same working stresses as in last example.

Rivets in double shear.

Shear strength of one rivet = $2 \times 0.6 \times 6 = 7.2$ tons.

Bearing strength of rivet on web plate = $\frac{7}{8} \times \frac{1}{2} \times 12 = 5.25$ tons.

Least $R = 5.25$ tons.

Shearing force at ends, $F = 2 \times 30 = 60$ tons.

From (3)

$$p = \frac{5.25 \times 24}{60} = 2.1 \text{ inches.}$$

This pitch is too small for a single line of rivets.

Therefore we must use angles $4\frac{1}{2}'' \times 4\frac{1}{2}'' \times \frac{1}{2}''$ with two rows of rivets placed zig-zag (Fig. 115).

Now, as there are *two* rivets in each pitch,

$$p = \frac{2Rh}{F} = \frac{2 \times 5.25 \times 24}{60} = 4.2 \text{ inches.}$$

Pitch = 4 inches.

A $4\frac{1}{2}$ inch angle is the *least* possible for two rows of rivets.

CHAPTER XII.

PLATE GIRDERS.

83. Plate girders.

A plate girder consists of horizontal flange plates connected to a thin vertical web plate by angle irons at the top and bottom, which are riveted to both web and flanges. The flanges are assumed to bear the whole of the bending stress, and the web is taken as resisting the shearing stress.

An example will best illustrate the method of determining the stresses, and the design of the members.

Design a plate girder bridge, span 60 feet, for a single line of railway. The two main girders to be 16 feet apart centre to centre, the track being carried on cross girders. Material mild steel.

Working stresses :

Tension	$7\frac{1}{2}$	tons per sq. in.
Compression ..	$6\frac{1}{2}$	” ” ”
Shear	6	” ” ”
Bearing	12	” ” ”

The dead load means the total dead weight of the structure complete.

The live load to consist of two type locomotives, followed by a train of wagons taken as a uniform load of 1·2 ton per foot run. The type locomotive consists of 4 axle loads, each of 14 tons, spaced 5 feet apart, giving a wheel base of 15 feet.

Depth of main girders.—The depth is usually taken from $\frac{1}{10}$ to $\frac{1}{8}$ of the span. In this case the depth is taken as 5 feet 6 inches.

Weight of main girders.—*Total dead load.*

For the approximate weight of girders

Professor Unwin's rule is :

$$W_1 = \frac{Wl r}{C_s - l r}$$

where W_1 = the weight of main girder.

W = total distributed load in tons (excluding W_1).

s = stress per square inch on flange at centre.

l = length in feet.

C = a coefficient—1400 for plate girders.

r = ratio of span to depth.

Professor Johnson gives the following rule for single track railway bridges :

$$\text{Plate girders } w \dots = 9l + 120,$$

$$\text{Lattice girders } w \dots = 7l + 200,$$

where l = span in feet, w = dead load per foot run in lbs.

The weight of each main girder in this example may be taken as approximately 18 tons.

The weight of the platform load, including cross girders, flooring, permanent way, &c., is taken at 0.6 ton per foot run of bridge.

The total dead load carried by one main girder is therefore

$$18 + 0.3 \times 60 = 36 \text{ tons.}$$

Spacing of cross girders.

The cross girders are usually placed 6 to 9 feet apart. The distance apart should be a multiple of the pitch of the riveting of flanges of main girder—that is, of 6 inches (see *Rivet pitch in flanges*). They may be spaced as shown below (Fig. 116).

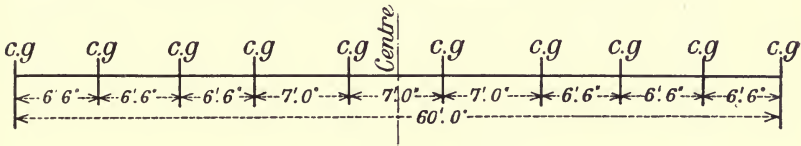

Fig. 116.

The joint of web of main girder is at the centre, so that a cross girder attachment does not come at the joint.

Main Girder.

MAXIMUM BENDING MOMENTS.

Dead load.

The maximum bending moment is at the centre,

$$= \frac{Wl}{8} = \frac{36 \times 60}{8} = 270 \text{ foot tons} = 3240 \text{ inch tons,}$$

and the bending moment curve is a parabola with centre ordinate

$= \frac{Wl}{8}$. The bending moment at any section distant x from support

$$= \frac{w}{2} (l - x)x$$

$$= 0.3(60 - x)x \dots\dots\dots(1).$$

Live load.

The maximum moments due to live load were found graphically at sections 5 feet apart as explained in Art. 42, Chapter VII., and

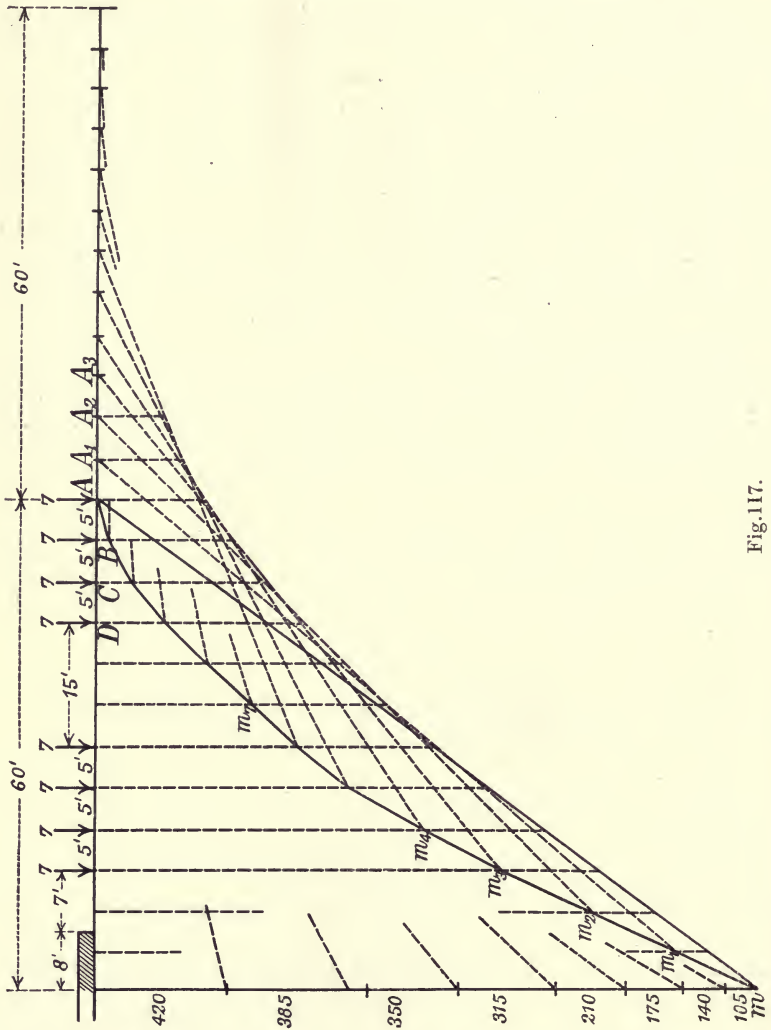

Fig. 117.

outlined here in Fig. 117. As the total axle loads are each 14 tons, the axle load for each main girder is 7 tons.

The leading axle is placed at one end of the span, and the polygonal line of moments (Am_4m) for the loads is drawn. Join

Am, then the bending moments for the leading axle at *A* are got by measuring the vertical intercepts at every 5 feet of span between the base *Am* and the polygonal line of moment. Next, suppose the bridge to move forward 5 feet, the train remaining stationary; then for the leading axle at *B* the intercepts are measured from the base *A₁m₁*, and so on till the train has passed off the bridge. The bending moments were all tabulated, and the maximum moments for corresponding sections in each half the girder were picked out. It is necessary to take the maximum moments in corresponding sections on each side of centre, because the train may travel in either direction over the span.

The following table gives the maximum bending moments :—

Maximum bending moments for live load.

Sections	5	10	15	20	25	30	feet
<i>B.M.</i> . .	155	275	350	400	440	425	ft. tons

In order to allow for *impact*, due to the sudden application of the live load, the stresses due to this load are to be multiplied by 2, or what is the same thing, the bending moments may be doubled, as the stresses are obtained from these moments. From Equation (1).

Maximum bending moments due to dead load.

Sections	5	10	15	20	25	30	feet
<i>B.M.</i> . .	83	150	203	240	263	270	ft. tons

Maximum bending moments due to dead and live loads.

Sections	5	10	15	20	25	30	feet
Live load . .	155	275	350	400	440	425	ft. tons
Impact . .	155	275	350	400	440	425	„ „
Dead load . .	83	150	203	240	263	270	„ „
Totals . .	393	700	903	1,040	1,143	1,120	„ „

SECTION OF MAIN GIRDER.

Lower chord.

This chord being in tension, it is necessary to deduct the rivet holes from the section of each angle iron and plate, so as

to get the *net section*. The area of section is got from the formula

$$M = H \cdot d = fAd.$$

$$\therefore A = \frac{M}{fd}.$$

Where A is the area required, M = bending moment, f = working stress, d = depth.

The maximum bending moment from above table = 1143 foot tons.

The greatest *net sectional area required* is

$$A = \frac{1143 \times 12}{7\frac{1}{2} \times 66} = 27.7 \text{ sq. in.}$$

Use $4'' \times 4'' \times \frac{1}{2}''$ angle irons and $\frac{3}{4}$ inch rivets.

Take only the area of the leg of angle iron which is attached to the chord plates.

Area of two angle legs less 2 rivet holes

$$= 2 \times 4 \times \frac{1}{2} - 2 \times \frac{3}{4} \times \frac{1}{2} = 3.25 \text{ sq. in.}$$

Area of three plates $18'' \times \frac{1}{2}''$

less 6 rivet holes

$$= 3 \times 18 \times \frac{1}{2} - 6 \times \frac{3}{4} \times \frac{1}{2} = 24.75 \text{ ,, ,,}$$

$$\text{Total area provided} = \underline{\underline{28}} \text{ ,, ,, (Fig. 118).}$$

Upper chord.

The greatest sectional area *required* is

$$A = \frac{1143 \times 12}{6\frac{1}{2} \times 66} = 32 \text{ sq. in.}$$

This being the compression boom, no allowance is made for rivet holes, the gross section of the angles and plates being taken.

The width of the chord is taken as $\frac{1}{40}$ span = $\frac{60}{40} = 1\frac{1}{2}$ foot.

Use as for lower chord angles $4'' \times 4'' \times \frac{1}{2}''$ and plates 18 inches wide.

Area of angle legs attached to chord

$$= 2 \times 4 \times \frac{1}{2} = 4 \text{ sq. in.}$$

Area of two plates $18'' \times \frac{1}{2}''$

$$= 2 \times 18 \times \frac{1}{2} = 18 \text{ ,, ,,}$$

Area of one plate $18'' \times \frac{9}{16} = 10 \text{ ,, ,,}$

$$\text{Total area provided} = \underline{\underline{32}} \text{ ,, ,, (Fig. 118).}$$

CURVE OF BENDING MOMENT.—LENGTH OF PLATES.

The curve of maximum bending moments due to both dead and live loads (Fig. 119) is drawn by setting up ordinates at every

5 feet of span equal to the maximum bending moments due to dead and live loads including impact. The upper curve is for the top chord ; it is repeated below for the lower chord.

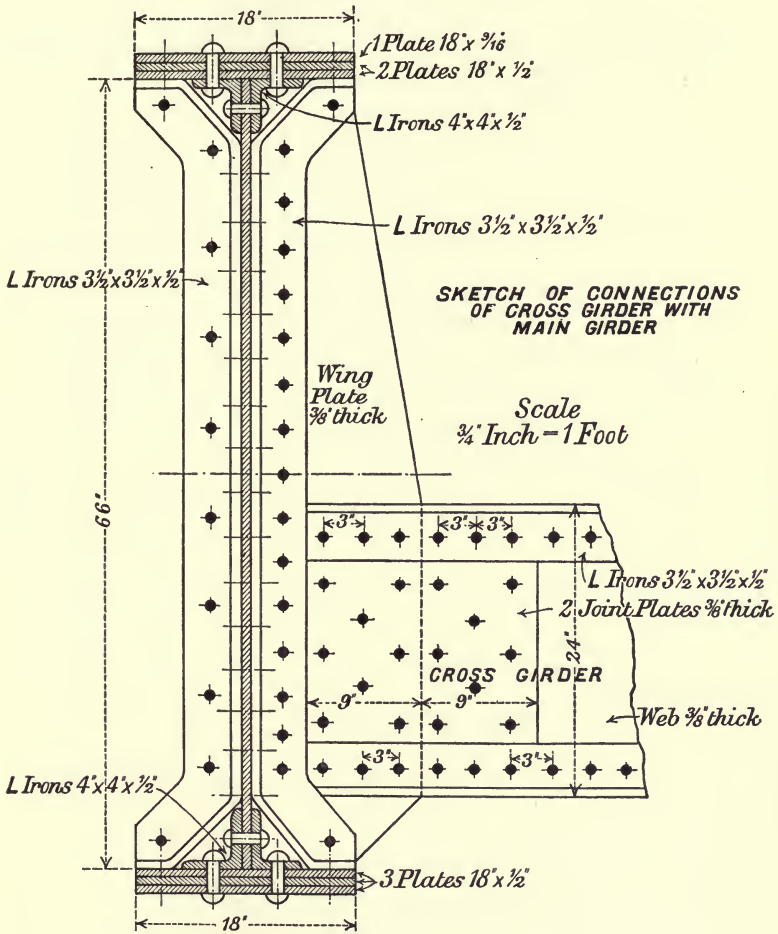

Fig. 118.

Lower chord.

The moment of resistance of the net section of the two angle irons is

$$3.25 \text{ sq. in.} \times 66 \times 7\frac{1}{2} = 1609 \text{ inch tons.}$$

$$= 134 \text{ foot tons.}$$

To represent this on the bending moment diagram set down a rectangle of height

$$\frac{134}{900} = 0.15 \text{ in.}$$

The moment of resistance of the net section of each plate is

$$\frac{24 \cdot 75}{3} \times 66 \times 7 \frac{1}{2} = 4084 \text{ inch tons.}$$

$$= 340.3 \text{ foot tons.}$$

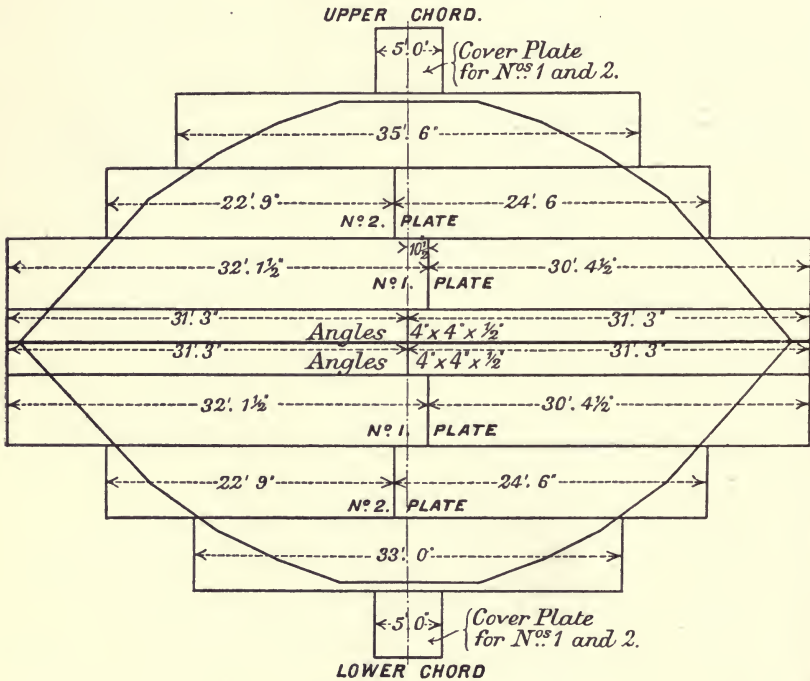

Scales.
 Horizontal $\frac{1}{5}$ Inch = 1 Foot.
 Vertical 1 Inch = 900 Ft. Tons

Fig. 119.

Set down in succession 3 rectangles, each of height

$$\frac{340.3}{900} = 0.37 \text{ in.}$$

The last rectangle reaches a little below the *B. M* curve, as the net area of the chord section = 28 square inches is slightly in excess of the area required.

Upper chord.

The moment of resistance of the section of angle irons is

$$\frac{4 \text{ sq. in} \times 66 \times 6\frac{1}{2}}{12} = 143 \text{ foot tons.}$$

On bending moment diagram set up a rectangle of height

$$\frac{143}{900} = 0.16 \text{ in.}$$

The moment of resistance of each of the two plates $18 \times \frac{1}{2}$ is

$$\frac{9 \times 66 \times 6\frac{1}{2}}{12} = 322 \text{ foot tons.}$$

Set up two rectangles, each of height

$$\frac{322}{900} = 0.36 \text{ in.}$$

The moment of resistance of one plate $18 \times \frac{9}{16}$ is

$$\frac{10.1 \times 66 \times 6\frac{1}{2}}{12} = 360 \text{ foot tons.}$$

Height of rectangle = $\frac{360}{900} = 0.4 \text{ in.}$

Length of plates.

The rectangles are closed by vertical lines representing the ends of the plates. These must come outside the *B.M* curve, and are usually taken about 9 inches beyond the curve, so as to overlap two or three rivets outside the curve.

The angle irons $4'' \times 4'' \times \frac{1}{2}''$ will have to extend about 15 inches beyond the centres of bearing, so that their total length is the full length of the girder—that is, 62 feet 6 inches. They will have a joint at the centre of span. Number 1 plate of the upper and lower chords must be of the same length as the angle irons. Plates Nos. 1 and 2 are so long they will require to be jointed near the centre. The position of the joints is got from Fig. 121, where it is found that in order to suit the pitch and number of rivets, 21 inches is required between the joints of these two plates, thus the joints come $10\frac{1}{2}$ inches on each side of centre of girder. The lengths of the different plates and the various joints are shown in Fig. 119; and details of the joints for plates and angle irons in Figs. 121 and 122.

Plates and angles as used can be had from 30 to 40 feet long.

Thickness of web.

The maximum live load shearing force at the end of span occurs when the leading axle is just about to pass off the bridge.

The loads would then be as shown in Fig. 117, and maximum live load shear

$$= \frac{7\{60 + 55 + 50 + 45 + 30 + 25 + 20 + 15\} + \frac{0.6 \times 8^2}{2}}{60}$$

$$= \frac{2119.2}{60} = 35.3 \text{ tons.}$$

Maximum dead load shear

$$= \frac{36}{2} = 18 \text{ tons.}$$

Total vertical shear = live load shear + impact + dead load shear

$$= 35.3 + 35.3 + 18$$

$$= 88.6 \text{ tons.} \dots \dots \dots (1).$$

Therefore, if the working shear stress is 6 tons per square inch, the net section of the web must be

$$\frac{88.6}{6} = 14.8 \text{ sq. in.}$$

If we assume a 3-inch pitch for the vertical riveting of the web, the number of rivet holes will be 22, approximating to 20 inches of depth. The net depth of web will then be 66 - 20 = 46 inches. If t = thickness of web,

$$46t = 14.8 \text{ sq. in.}$$

$$t = \frac{14.8}{46} = 0.32 \text{ in.}$$

$$= \frac{7}{16} \text{ inch (say).}$$

The web will be made of this thickness for the full length of the girder.

Rivet pitch in flanges.

From Equation (3), Art. 82,

$$p = \text{pitch} = \frac{Rh}{F} \dots \dots \dots (2).$$

To find R the least resistance of one rivet compare the bearing and shearing resistances.

The bearing resistance of $\frac{3}{4}$ -inch rivet in $\frac{7}{16}$ -inch plate is

$$\frac{3}{4} \times \frac{7}{16} \times 12 = 3.9 \text{ tons.}$$

The shearing resistance of a $\frac{3}{4}$ -inch rivet, the rivets being in double shear, is

$$\frac{2\pi d^2}{4} \times f_s = 2 \times 0.44 \times 6 = 5.28 \text{ tons.}$$

The bearing resistance being *least* must be taken.

$$F \text{ by Equation (1) } = 88.6 \text{ tons.}$$

Substituting in Equation (2)

$$p = \frac{3.9 \times 66}{88.6} = 3,$$

that is, 3-inch pitch for the riveting of angles to web.

For the riveting of angles to the flange plates, the pitch may be 6 inches, giving 4 rivets per foot in two rows.

To find the distance from one support at which the pitch of the rivets connecting angles to web may be doubled.

At a section 22 feet from either support, the maximum live load shear occurs when the leading axle is over the section, the longer segment of the span being loaded with the live load.

There will then be 6 axle loads on the span, and

$$\begin{aligned} \text{Max. live load shear} &= \frac{7(38 + 33 + 28 + 23 + 8 + 3)}{60} \\ &= 15.5 \text{ tons.} \end{aligned}$$

$$\begin{aligned} \text{Max. dead load shear at same section} \\ &= 18 - 0.3 \times 22 \\ &= 11.4 \text{ tons.} \end{aligned}$$

$$\begin{aligned} \therefore \text{Max. shear with impact} \\ &= 2 \times 15.5 + 11.4 = 42.4 \text{ tons} \end{aligned}$$

By Equation (3), Art. 82,

$$\begin{aligned} p = \text{pitch} &= \frac{Rh}{F} \\ &= \frac{3.9 \times 66}{42.4} = 6 \text{ inches.} \end{aligned}$$

Therefore the pitch may be changed to 6 inches at a distance of 22 feet from either support, but as there will be a large excess of rivet strength in the neighbourhood of this point, the pitch may be changed at a point rather nearer the support, say, at $x = 20$ feet.

Vertical joint of web.—Web splices.

Steel plates with sheared edges can be obtained $\frac{7}{16}$ inch thick up to 6 feet wide in lengths of 35 feet. Hence only one vertical joint at the centre will be required for this girder.

The joint is shown in Fig. 120, which shows the upper half of joint only, the lower half being similar. The rivets going through the angle irons are not available for the joint. The vertical pitch is taken as 4 inches.

In calculating the number of rivets in any one horizontal row it is assumed that each row transmits the longitudinal stress due to flexure on the section of that strip of web whose edges are midway between the row in question and the row above and below. The intensity of stress on the section of a strip varies as its distance from the neutral surface, which in this case practically coincides with the centre of depth.

First row.

Width of strip = $7\frac{1}{2}$ inches.

Intensity of stress at centre of strip = $\frac{3.0}{3} \times 6\frac{1}{2} = 6$.

Limiting resistance of strip = $6 \times 7\frac{1}{2} \times \frac{7}{16} = 19.7$ tons.

The rivets are in double shear, and the bearing resistance 3.9 tons is least.

\therefore Number of rivets in first row will be

$$\frac{19.7}{3.9} = 5 \text{ on each side of the joint.}$$

Second row.

Width of strip = $3\frac{1}{2}$ inches.

Intensity of stress = $\frac{3.4}{3} \times 6\frac{1}{2} = 4\frac{1}{2}$.

Limiting resistance of second strip = $4\frac{1}{2} \times 3\frac{1}{2} \times \frac{7}{16} = 8.4$.

Number of rivets required = $\frac{8.4}{3.9} = 3$ on each side of the joint.

4 rivets are used instead of 3 for convenience in size of joint bar.

Third row.

Width of strip = 4 inches.

Intensity of stress = $\frac{3.0}{8} \cdot 6\frac{1}{2} = 4$.

Limiting resistance of third strip = $4 \times 4 \times \frac{7}{16} = 7$.

Number of rivets required = $\frac{7}{3.9} = 2$ on each side.

As not less than 2 rivets on each side of the joint are advisable, the remainder of the vertical riveting can be as in Fig. 120.

Thickness of joint plates and bars.—The net sectional area of the joint plates and bars along the vertical line containing most rivet holes must be at least equal to the net section of the web plate along the same line—that is,

$$2 \times \frac{3}{8} (22 - 6 \times \frac{3}{4}) + 2 \times \frac{3}{8} (7\frac{1}{2} - \frac{3}{4}) > \frac{7}{16} (33 - 8 \times \frac{3}{4}),$$

a condition amply fulfilled in this case.

Joints of the upper and lower chords.

Only one joint is required in each of the chords. These joints are near the centre of span (see Fig. 119).

The length of the cover plates and the number of rivets required on each side of a joint are to be determined thus:—

The shearing resistance of one rivet, it being in single shear, is

$$6 \times \frac{\pi d^2}{4} = 6 \times 0.44 = 2.64 \text{ tons,}$$

and its bearing resistance in a $\frac{1}{2}$ -inch plate is

$$12 \times \frac{1}{2} \times \frac{3}{4} = 4.5 \text{ tons.}$$

The shearing resistance being least is to be taken as the working resistance of one rivet.

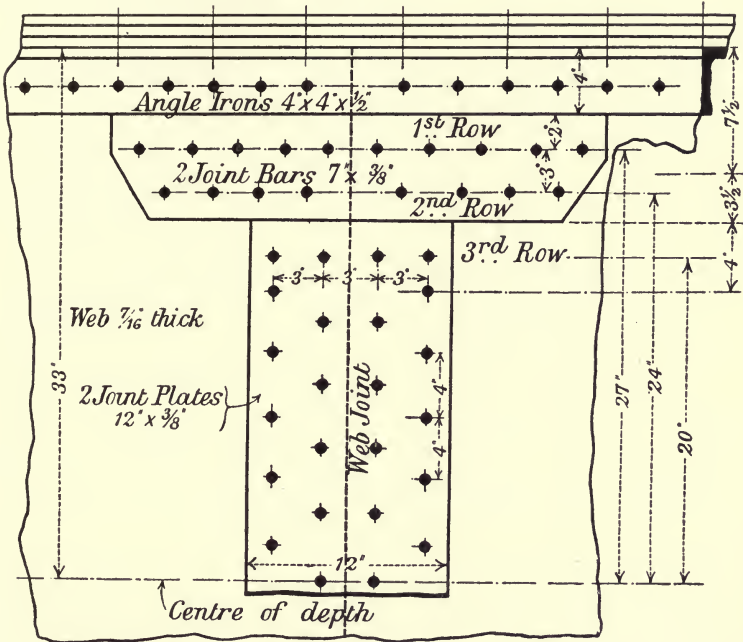

HALF ELEVATION OF WEB JOINT.

Fig. 120.

The number of rivets required for the joint of one plate (on each side of the joint) \times the working resistance of one rivet must be equal to the working resistance of the plate itself.

Therefore the number of rivets required for each joint of top chord is

$$\frac{18 \times \frac{1}{2} \times 6\frac{1}{2}}{2.64} = 23,$$

and for the bottom chord is

$$\frac{(18 - 2 \cdot \frac{3}{4}) \times \frac{1}{2} \times 7\frac{1}{2}}{2.64} = 24.$$

Fig. 121 shows the arrangement of the joint, which is similar both for the upper and lower chords. The cover plates are of the same thickness and sectional area as the plates joined. The joints are grouped, so that one cover plate covers the joints of the two plates. The plates break joint so that the cross section of the cover plate need only be equal to that of one of the plates joined. To fulfil this condition it is necessary to have 24 rivets through the lap between two successive joints, and also between each end of the cover plate and the nearest joint.

Jointing of longitudinal angle irons.

These angle irons must have a joint at the centre of span, making their length about 31 feet 3 inches.

Cross sectional area of one angle is

$$\frac{1}{2} (4 + 3\frac{1}{2}) = 3.75 \text{ sq. in.}$$

Net sectional area deducting 2 rivet holes $\frac{3}{4}$ -inch in diameter is

$$\frac{1}{2} (7\frac{1}{2} - 2 \times \frac{3}{4}) = 3 \text{ sq. in.}$$

JOINT FOR PLATES 1 AND 2 AT CENTRE OF SPAN.

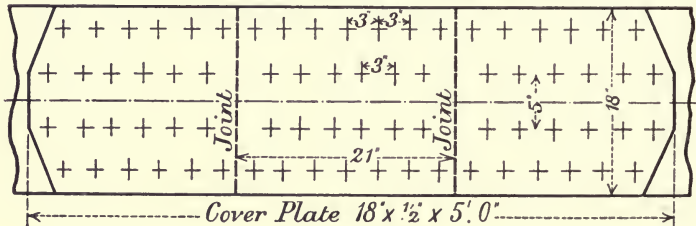

Fig. 121.

The rivets are in single shear, considering the joint of one angle iron only. The shearing resistance, 2.64 tons, is less than the bearing resistance. Therefore shearing resistance \times number of rivets on one side of the joint must be equal to the limiting compressive resistance of the cross section, or the limiting tensile resistance of the net section, whichever is greater, so as to make the joints in upper and lower chords alike. Limiting compressive resistance of cross section is

$$6\frac{1}{2} \times 3.75 = 24.38 \text{ tons.}$$

Limiting tensile resistance of net section is

$$7\frac{1}{2} \times 3 = 22.5 \text{ tons.}$$

Hence number of rivets required is

$$\frac{24.38}{2.64} = 8$$

on each side of the joint—4 in each limb.

The joint is made by riveting a bent cover plate or wrapper inside the hollow of the angle iron (Fig. 122).

The net section of the wrapper must be at least 3 square inches, that being the net section of the angle iron.



Fig. 122.

Try a wrapper $3\frac{1}{4}'' \times 3\frac{1}{4}'' \times \frac{1}{16}''$ and deduct two $\frac{3}{4}''$ rivets

$$\frac{1}{16} (3\frac{1}{4} + 2\frac{9}{16} - 2 \cdot \frac{3}{4}) = 3 \text{ sq. in.}$$

The length of wrapper must be such as to take 4 rivets on each limb.

STIFFENERS.

The web of the main girder requires stiffening so as to resist buckling. The stiffeners are usually angle or Tee irons, spaced at a distance apart near the supports of half the depth of the girder and near the centre of span, at distances of about three-quarters the depth of girder. In no case should the distance apart be greater than the depth of girder.

In the present example the vertical angle irons and wing plates of each cross girder attachment (Fig. 118) serve to stiffen the web effectively in the spaces adjoining them; so that if two stiffeners are placed in each of the first cross girder spaces from the supports and one in the centre of each of the other cross girder spaces it should suffice.

The stiffeners may be taken of Tee section 6 inches by 3 inches by $\frac{3}{8}$ inches.

Cross Girder.

Live load.

From the accompanying sketch (Fig. 123), which shows three

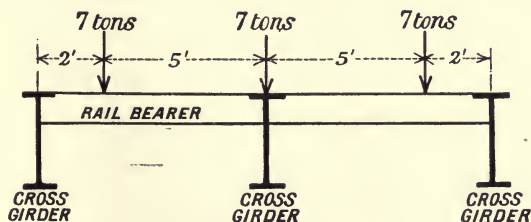

Fig. 123.

adjacent cross girders, we find the maximum live load that can

come on one cross girder under one rail; the axle load on each wheel of the locomotive being taken as before 7 tons, with axles 5 feet apart. This maximum live load which is equal to the reaction at centre cross girder

$$= 7 + \frac{2 \times 7 \times 2}{7} = 11 \text{ tons.}$$

Fig. 124 shows the distribution of the live load on cross girder, 11 tons on each rail.

Dead load.

The dead load has been taken as 0.6 ton per foot run of main girder. Therefore the total dead load on one cross girder is

$$0.6 \times 7 = 4.2 \text{ tons.}$$

Max. live load bending moment = $11 \times 5\frac{1}{2} = 60\frac{1}{2}$ foot tons.

Max. dead load bending moment = $\frac{4.2 \times 16}{8} = 8.4$ foot tons.

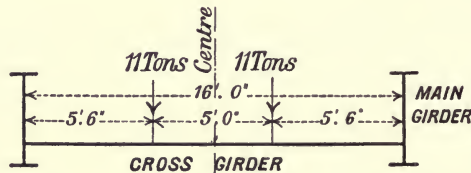

Fig. 124.

Total maximum bending moment with impact is

$$\begin{aligned} 2 \times 60\frac{1}{2} + 8.4 &= 129.4 \text{ foot tons.} \\ &= 1552.8 \text{ inch tons.} \end{aligned}$$

Cross section.—Take the depth equal to 2 feet and the diameter of rivets $\frac{3}{4}$ inch.

Upper chord.—Compression.

$$\begin{aligned} \text{Required area} &= \frac{M}{fh} = \frac{1552.8}{6\frac{1}{2} \times 2 \times 12} \\ &= 10 \text{ sq. in.} \end{aligned}$$

Use angle irons $3\frac{1}{2} \times 3\frac{1}{2} \times \frac{1}{2}$.

The area of two legs of angles attached to chord
 $= 2 \times 3\frac{1}{2} \times \frac{1}{2} = 3.5$ sq. in.

Area of 2 plates $9'' \times \frac{3}{8} = 2 \times 9 \times \frac{3}{8} = 6.75$ „ „

Area provided = 10.25 „ „

Lower chord.—Tension.

$$\begin{aligned} \text{Net sectional area required} &= \frac{1552.8}{7\frac{1}{2} \times 2 \times 12} \\ &= 8.7 \text{ sq. in.} \end{aligned}$$

Net area of legs of angles attached to chord

$$= 2\left\{3\frac{1}{2} - \frac{3}{4}\right\}\frac{1}{2} = 2.75 \text{ sq. in.}$$

$$\text{Net area of 2 plates } 9'' \times \frac{7}{16} = 2\left\{9 - 2 \times \frac{3}{4}\right\} \frac{7}{16} = \frac{6.50}{16} \text{ ,, ,,}$$

$$\text{Net area provided} = \underline{9.25} \text{ ,, ,,}$$

Thus, the maximum cross sections at centre are :

Upper chord, 2 angles, $3\frac{1}{2}'' \times 3\frac{1}{2}'' \times \frac{1}{2}''$; 2 plates $9'' \times \frac{3}{8}''$.

Lower chord, 2 angles, $3\frac{1}{2}'' \times 3\frac{1}{2}'' \times \frac{1}{2}''$; 2 plates $9'' \times \frac{7}{16}''$.

The length of the plates can be found by drawing the bending moment diagram exactly as in Fig. 119.

Web.

$$\text{Max. live load shear} = 11 \text{ tons.}$$

$$\text{Max. dead load shear} = 2.1 \text{ tons.}$$

$$F = \text{total shear including impact} = 2 \times 11 + 2.1 \\ = 24.1 \text{ tons.}$$

Net depth of web deducting 5 rivet holes (see Fig. 118)

$$= 24 - 5 \cdot \frac{3}{4} = 20\frac{1}{4} \text{ inches,}$$

$$\text{then } t = \frac{F}{hf_s} = \frac{24.1}{20\frac{1}{4} \times 6} \\ = 0.2 \text{ in.} = \frac{1}{4} \text{ inch ;}$$

but, as it is not advisable to use any plate less than $\frac{3}{8}''$, take thickness of web = $\frac{3}{8}''$.

Pitch of rivets connecting angles to web.

As in Equation (2), Art. 82, if N = number of rivets per foot run,

R = least resistance of one rivet,

$$N = \frac{F}{Rh}.$$

Shearing resistance of one rivet in double shear

$$= 2 \times 0.44 \times 6 = 5.28 \text{ tons.}$$

Bearing resistance of $\frac{3}{4}$ -inch rivet in $\frac{3}{8}$ -inch plate

$$= 12 \times \frac{3}{8} \times \frac{3}{4} = 3.4 \text{ tons,}$$

$$\therefore N = \frac{24.1}{2 \times 3.4} = 3.6$$

$$= 4 \text{ rivets per foot.}$$

Therefore the pitch is 3 inches.

Attachment of cross girder to main girder.

Fig. 118 shows detail of this attachment. It is necessary to determine the number of rivets on each side of the vertical joint between the web of cross girder and the wing plate of the main girder, which are equal thickness.

Max. shearing force at end as above = 24.1 tons.

Least resistance of a $\frac{3}{4}$ -inch rivet in $\frac{3}{8}$ -inch plate = 3.4 tons.

Therefore the number of rivets required, considering the shearing force only, is

$$\frac{24.1}{3.4} = 8.$$

But, owing to the bending action which must exist at the end of cross girder, it is advisable to increase this number by, say, 50 per cent. As seen, 6 have been added, making 14 rivets, which forms a convenient group. The same number of rivets are required to fasten the wing plate to the vertical angle irons of the main girder and to connect these angles to the web.

Rail bearers between cross girders may be small built-up girders or rolled steel joists.

CHAPTER XIII.

COLUMNS AND STRUTS.

84. Short columns.

If a load P acts along the axis of a short column, the ratio of whose length to diameter is small, usually not greater than 5 to 1, the column will fail by direct crushing. The relation between the crushing load and the stress produced is

$$f = \frac{P}{A}$$

where P = the crushing load.

A = area of cross section.

f = intensity of compressive stress, or crushing strength per unit of area.

Columns of medium length fail partly by crushing and partly by bending.

Long columns fail wholly by bending.

85. Formulæ for the strength of columns or struts.

Several formulæ are in use for ascertaining the strength of columns ; they are derived partly from theory and partly from the results of experiments.

For the proof or method of obtaining these formulæ refer to 'Strength and Elasticity of Structural Members,' Chapter X., by the author.

Rankine's formula for columns of medium length. Column hinged or pivoted at the ends.

Load axial.

$$p = \frac{P}{A} = \frac{f}{1 + a \frac{l^2}{k^2}} \dots \dots \dots (1)$$

where a is a constant depending on the material.

A is the area of cross section.

l is the length of the column or strut.

k is the radius of gyration of cross section with respect to the axis about which the resistance to bending is least, namely, the axis about which I the Moment of Inertia is least.

$$k^2 = \frac{I}{A}.$$

In applying this formula it is well to note that if f in above formula is taken as the ultimate compressive stress, then P is the *breaking load*, and the safe load is got by dividing P by a suitable factor of safety. For a *steady* load, this factor of safety should be 4 or 5 for wrought iron or steel; 6 for cast iron; and 10 for timber.

On the other hand if f is taken as the *safe* compressive stress for a short length of the material, then P is the safe load; and p is the working stress per square inch; where l , k , and A are in inch units. The following table gives *safe* values for f , and the values of the constant a for different materials:—

Material	f Tons per square inch	a
Wrought iron . . .	4 to 5	$\frac{1}{5000}$
Mild steel	6 to 7	$\frac{1}{7500}$
Cast iron	6 to 7	$\frac{1}{1600}$
Timber	$\frac{1}{2}$	$\frac{4}{3000}$

Rankine's formula applies to columns for which the ratio $\frac{l}{k}$ lies between 25 and about 150.

Gordon's formula.

This formula, which is similar to Rankine's, is

$$p = \frac{P}{A} = \frac{f}{1 + c \frac{l^2}{b^2}} \dots \dots \dots (2),$$

where b , the *least* breadth of the section, is used instead of k , the least radius of gyration. The constant c depends *both* on the material and on the type of section.

The following table gives the values of c in Gordon's formula.

The value of f is the same as for Rankine's.

Material	Section	Value of c
Wrought iron . . .	L. T. H. I. channel and hollow square	$\frac{1}{300}$
	Hollow round	$\frac{1}{900}$
	Solid round	$\frac{1}{550}$
	Solid rectangular	$\frac{1}{700}$
Mild steel	Built up of plates, angles, &c.	$\frac{1}{400}$
	Hollow round	$\frac{1}{625}$
	Solid round	$\frac{1}{350}$
Cast iron	Solid rectangular	$\frac{1}{600}$
	Hollow round	$\frac{1}{200}$
Timber	Solid round	$\frac{1}{100}$
	Solid round or rectangular	$\frac{1}{62}$

86. Length of strut as affected by method of fixing.

In Rankine's and Gordon's formulæ, as given in Equations (1) and (2), both ends of the column or strut are taken as pivoted, and l is the length of the column between the supports, Fig. 125 (a).

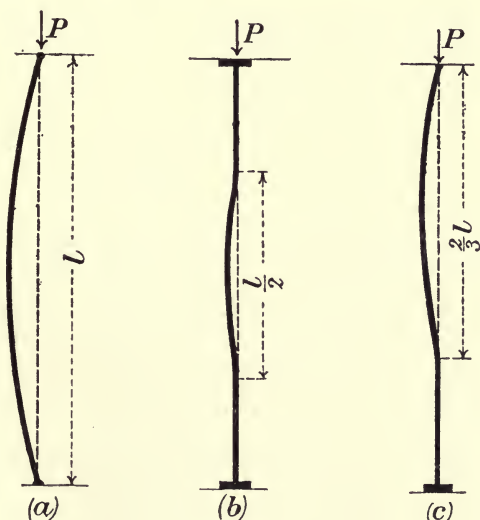

Fig. 125.

If both ends of the column are *fixed*, Fig. 125 (b), the load which it will carry before bending is the same as for a strut of half the length pivoted at the ends, and we must substitute $\frac{l}{2}$ for l . If

one end of the column is fixed and the other end pivoted, Fig. 125 (c), we must substitute $\frac{2}{3}l$ for l .

Rankine's formulæ for these three cases are:

Both ends of column pivoted.

$$p = \frac{P}{A} = \frac{f}{1 + a \frac{l^2}{k^2}} \dots \dots \dots (3).$$

Both ends fixed.

$$p = \frac{P}{A} = \frac{f}{1 + \frac{a}{4} \frac{l^2}{k^2}} \dots \dots \dots (4).$$

One end fixed, the other end pivoted.

$$p = \frac{P}{A} = \frac{f}{1 + \frac{4}{9} a \frac{l^2}{k^2}} \dots \dots \dots (5).$$

The values of f and a being as in previous table.

In all these cases the resultant load P should coincide with the axis of the column.

87. Design of strut members.

From Rankine's formula—

$$p = \frac{P}{A} = \frac{f}{1 + a \frac{l^2}{k^2}}$$

we get

$$\text{Area required} = \left(1 + a \frac{l^2}{k^2}\right) \frac{\text{max. load}}{f} \dots \dots \dots (1).$$

Now the safe stress f is usually specified, and the maximum load, length of strut, and constant ' a ' are given. First assume an approximate cross section, the area of which is somewhat greater than $\frac{\text{max. load}}{f}$.

For this assumed cross section the value of k^2 is calculated, and the area required obtained from (1). If the area assumed is slightly greater than the area required it will suit. If too small or much too great a new cross section should be assumed and the area again calculated till a satisfactory agreement is obtained.

Another method.—Having found k^2 , calculate f and see if it agrees with or is slightly less than the specified unit stress, and if so, a section is designed.

Example.

The compression chord of bridge is 20 feet long with fixed ends, design a suitable cross section for a safe stress of 6 tons per square inch. The axial compressive stress is 348 tons.

From Equation (1).

$$\text{Area required} = \left(1 + \frac{1}{30000} \frac{l^2}{k^2}\right) \frac{348}{6}.$$

Since the factor in brackets is greater than 1, in order to get an approximate section take

$$\text{Area} = \frac{348}{5\frac{1}{2}} = 63 \text{ sq. in.}$$

Assume a cross section of box shape similar in form to Fig. 111, Art. 81, consisting of :

One top plate 24 inches by $\frac{5}{8}$ inch.

Two side plates 21 inches by $\frac{5}{8}$ inch.

Four angles $4\frac{1}{2}$ inches by 4 inches by $\frac{5}{8}$ inch.

The area of which is 61 square inches.

For this section the least $I = 3860$, and least $k^2 = 63.3$.

Therefore

$$\begin{aligned} \text{Area required} &= \left\{1 + \frac{1}{30000} \cdot \frac{20^2 \times 12^2}{63.3}\right\} \frac{348}{6} \\ &= \frac{1.03 \times 348}{6} = 59.8 \text{ sq. in.} \end{aligned}$$

Sixty-one square inches have been provided in the section assumed, and this so closely approximates to the area required that it can be taken. If there had been any marked difference in the areas a new cross section should be assumed and recalculated. Generally after the first trial it is easy to see how the cross section should be altered so as to bring it correct.

EXAMPLES.

1. A mild steel column or strut is I-shaped in cross section, 12 inches deep, flanges 6 inches wide, and weighs 54 lbs. per foot run. The length is 14 feet. Find the safe load it will carry if the ends are flat and well fixed.

Rankine's formula for pivoted ends is

$$p = \frac{P}{A} = \frac{f}{1 + a \frac{l^2}{k^2}},$$

where $a = \frac{1}{7500}$; k = least radius of gyration.

As the ends are fixed for l substitute $\frac{l}{2}$, then

$$p = \frac{P}{A} = \frac{f}{1 + \frac{a}{4} \frac{l^2}{k^2}}$$

For calculating the *safe* load f may be taken as 6 tons per square inch, and from table of sections $A = 15.88$ square inches; least $k = 1.33$ inch units.

$$\begin{aligned} \therefore P &= \frac{6 \times 15.88}{1 + \frac{1}{30000} \cdot \left(\frac{14 \times 12}{1.33}\right)^2} \\ &= 62\frac{1}{4} \text{ tons.} \end{aligned}$$

2. The cross section of a mild steel column is composed of a steel joist 14" deep, flanges 6" wide, weighing 57 lbs. per foot run, with a flat 12" \times $\frac{1}{2}$ " riveted to each flange. Length, 18 feet. One end is fixed, the other end pivoted. Determine what safe load it will carry. Fig. 126.



Fig. 126.

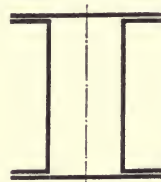

Fig. 127.

Since one end of the column is fixed and the other end free, for l in Rankine's general formula write $\frac{3}{4}l$;

then

$$P = \frac{fA}{1 + \frac{4a}{9} \left(\frac{l}{k}\right)^2}$$

$A = 28.75$ square inches; $f = 6$ tons per square inch; least $k = 2.45$ inch units.

$$\begin{aligned} \therefore P &= \frac{6 \times 28.75}{1 + \frac{1}{16875} \left(\frac{18 \times 12}{2.45}\right)^2} \\ &= 118 \text{ tons.} \end{aligned}$$

3. The cross section of a mild steel column as in Fig. 127 consists of two channel sections 12" \times 3 $\frac{1}{2}$ ", weighing 26.1 lbs. per foot run, and two flats each 14" \times $\frac{1}{2}$ "; length, 24 feet. If both ends are taken as pivoted, determine what load it will carry with safety. $A = 29.35$ square inches.

In order that the flats should extend $\frac{1}{4}$ inch at each end beyond the edges of flanges the distance between channels should be $6\frac{1}{2}$ inches, and least $k = 4.14$ inch units.

$$P = \frac{fA}{1 + \frac{a^2}{k^2}}, \quad a = \frac{1}{7500},$$

$$\begin{aligned} \therefore P &= \frac{6 \times 29.35}{1 + \frac{1}{7500} \left(\frac{24 \times 12}{4.14} \right)^2} \\ &= 108 \text{ tons.} \end{aligned}$$

4. The vertical post of a bridge consists of 4 angle irons $6'' \times 4'' \times \frac{1}{2}''$, Fig. 128, braced together with lattice bracing $\frac{1}{2}$ inch thick. The angles are well riveted to the top and bottom chords, and the post may be taken as fixed at the ends. Determine the safe load. Length, 16 feet.



Fig. 128.

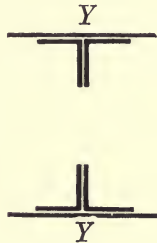

Fig. 129.

For fixed ends
$$P = \frac{fA}{1 + \frac{a^2}{4} \left(\frac{l}{k} \right)^2}.$$

$A = 19$ square inches ; least $k = 2.91$ inch units.

$$\begin{aligned} \therefore P &= \frac{6 \times 19}{1 + \frac{1}{30000} \left(\frac{16 \times 12}{2.91} \right)^2} \\ &= 99.5 \text{ tons.} \end{aligned}$$

5. Design the cross section for a vertical post of a girder 18 feet long, the total stress being 110 tons. The section to consist of 4 angles and 2 plates as in Fig. 129. The angles are connected by diagonal bracing $\frac{1}{2}$ inch thick, which may be neglected in calculation. The post is strongly riveted to the side plates of chords, and may be considered fixed at the ends.

It will be first necessary to assume a section, and see if it fulfils the requirements ; if not, it may have to be slightly altered.

Rankine's formula is

$$p = \frac{P}{A} = \frac{f}{1 + \frac{a l^2}{4 k^2}}; f = 6 \text{ tons per sq. in.}$$

$$\therefore \text{Area required} = \left(1 + \frac{a l^2}{4 k^2}\right) \frac{\text{load}}{6}.$$

Now $1 + \frac{a l^2}{4 k^2}$ will be somewhat greater than 1, hence, if we divide the load by 5, we shall get an approximate area.

$$\text{Approximate area} = \frac{110}{5} = 22 \text{ sq. in.}$$

Assume a section consisting of 4 angles $3\frac{1}{2}'' \times 3\frac{1}{2}'' \times \frac{3}{8}''$, and two plates $12'' \times \frac{1}{2}''$.

$$\begin{aligned} \text{This area} &= 4 \times 2.485 + 2 \times 12 \times \frac{1}{2} \\ &= 21.94 \text{ sq. in.} \end{aligned}$$

Moment of Inertia of one angle $3\frac{1}{2}'' \times 3\frac{1}{2}'' \times \frac{3}{8}'' = 2.80$.

Distance of its centre of area from centre line YY = 1.25 in.

Hence the least Moment of Inertia of cross section which is about YY

$$\begin{aligned} &= 4 (2.8 + 2.485 \times 1.25^2) + 2 \times \frac{\frac{1}{2} \cdot 12^3}{12} \\ &= 171.12 \text{ inch units.} \end{aligned}$$

$$\therefore \text{Least } k^2 = \frac{171.12}{21.94} = 7.8.$$

$$l^2 = 46656.$$

Therefore, safe working stress

$$\begin{aligned} p &= \frac{6}{1 + \frac{1}{30000} \left(\frac{46656}{7.8} \right)} \\ &= \frac{6}{1 + 0.2} = 5 \text{ tons per sq. in.} \end{aligned}$$

$$\therefore \text{Area required} = \frac{110}{5} = 22 \text{ sq. in.}$$

which is almost exactly the area provided, *i.e.* 21.94 square inches. The section chosen will therefore suit.

88. Euler's formula for long columns.

Ratio of $\frac{l}{k}$ greater than about 160. Euler's formula, which is applicable only to columns where the ratio of length to diameter is great, so that the column fails by buckling, is

$$P = \frac{\pi^2 EI}{l^2} \dots\dots\dots(6).$$

where P is the limiting load which the strut can support.

E Young's modulus of elasticity.

I the *least* Moment of Inertia of the cross section about an axis through the centre of area of the section.

l the length of *pivoted* strut or column.

This equation is for very long struts under ideal conditions of initial straightness, perfectly axial load, and a perfectly homogeneous material, conditions difficult to fulfil in actual practice.

If p is the breaking stress,

A is the area of cross section,

then
$$p = \frac{P}{A}, \text{ and } I = Ak^2;$$

hence
$$p = \frac{\pi^2 E}{\left(\frac{l}{k}\right)^2} \dots\dots\dots(7),$$

with a factor of safety of 5 for mild steel or wrought iron.

$$\text{Working stress} = \frac{p}{5} = \frac{\pi^2 E}{5 \left(\frac{l}{k}\right)^2}.$$

89. Fixed ends.

If the strut is *fixed* at both ends, the load which it will stand before yielding is the same as for a strut of half the length pivoted at the ends ; so for l in (6) substitute $\frac{l}{2}$

If the ends are fixed

$$P = \frac{4\pi EI}{l^2} \dots\dots\dots(8).$$

If one end fixed and the end pivoted, for l write $\frac{3}{4}l$.

$$P = \frac{9\pi^2 EI}{4l^2} \dots\dots\dots(9).$$

90. Modification of Euler's formula.

Rankine's formula is a modification of Euler's formula. For *very short columns*, if f is the crushing strength of the material, and A the area of cross section,

$$\text{Breaking load} = fA.$$

For *very long columns*, according to Euler,

$$\text{Breaking load} = \frac{\pi^2 EI}{l^2}.$$

Then the formula

$$P = \text{breaking load} = \frac{fA}{1 + fA \frac{l^2}{\pi^2 EI}} \dots\dots (10)$$

may be taken as true for columns of all lengths in practice, because in this formula l is *small*, the denominator is 1 (app.) and

$$P = fA.$$

When l is *great* we can neglect 1 in the denominator, and

$$P = \frac{\pi^2 EI}{l^2}.$$

And $I = Ak^2$, where k is the least radius of gyration of the section, hence from (10)

$$P = \frac{fA}{1 + a \frac{l^2}{k^2}}$$

where $a = \frac{f}{\pi^2 E}$; but, if a is calculated from Euler's formula, we get values which make the strut too strong, as in practice ideal straightness, symmetrical loading, and symmetry of elasticity do not exist, hence the formula is treated as empirical and the constants f and a are determined for experiment.

91. Johnson's parabolic formula.

Professor J. B. Johnson has deduced the formula

$$p = \frac{P}{A} = f - b \left(\frac{l}{k} \right)^2 \dots\dots\dots (11).$$

When p is the buckling stress,

f is the 'elastic limit' stress in compression of the material.

$$b \text{ a constant} = \frac{f^2}{4\pi^2 E}.$$

If a curve is plotted (Fig. 130 (1)), representing Euler's formula when applied to wrought iron columns, with ratios of l to k as abscissæ and buckling stresses as ordinates, then Professor Johnson's formula

$$p = f - b \left(\frac{l}{k} \right)^2$$

is the equation to a parabolic curve, tangential to Euler's curve, where $\frac{l}{k} = 150$, and with its apex at the elastic limit of the metal.

Fig. 130 (2).

WROUGHT IRON COLUMNS.

Pin ends $\frac{l}{k} \leq 170$; $p = 34000 - 0.67 \left(\frac{l}{k}\right)^2$.

Flat or fixed ends . . . $\frac{l}{k} \leq 210$; $p = 34000 - 0.43 \left(\frac{l}{k}\right)^2$.

MILD STEEL COLUMNS.

Pin ends $\frac{l}{k} \leq 150$; $p = 42000 - 0.97 \left(\frac{l}{k}\right)^2$.

Flat ends $\frac{l}{k} \leq 190$; $p = 42000 - 0.62 \left(\frac{l}{k}\right)^2$.

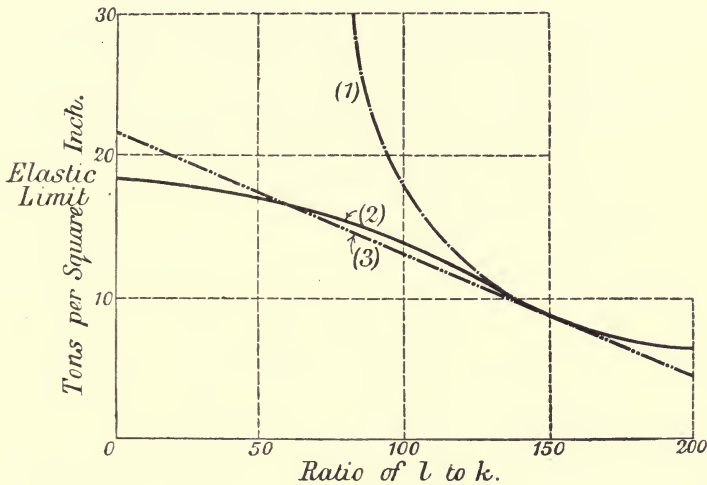

Fig. 130.

CAST IRON COLUMNS.

Round ends $\frac{l}{k} \leq 70$; $p = 60000 - \frac{25}{4} \left(\frac{l}{k}\right)^2$.

Flat ends $\frac{l}{k} \leq 120$; $p = 60000 - \frac{9}{4} \left(\frac{l}{k}\right)^2$.

TIMBER—FLAT OR FIXED ENDS.

Yellow pine $\frac{l}{d} \leq 60$; $p = 3300 - 0.7 \left(\frac{l}{d}\right)^2$.

White oak $\frac{l}{d} \leq 60$; $p = 3500 - 0.8 \left(\frac{l}{d}\right)^2$.

For timber *d* is the least lateral dimension.

The *working stress* must not exceed $\frac{p}{n}$, where $n = 4$ to 5 for wrought iron or steel, 6 for cast iron, and 10 for timber.

92. Mr. T. H. Johnson's straight line formula.

This formula is of the form

$$p = \frac{P}{A} = a - b \left(\frac{l}{k} \right)$$

where a and b are empirical constants. It is the equation to a straight line tangential to Euler's curve. (Fig. 130 (3).)

The formula is simple, and easy of application. The objection to it is that for short columns it gives too high a value of P .

WROUGHT IRON COLUMNS.

$$\text{Hinged ends} \dots \dots \dots \frac{l}{k} \leq 178 ; p = 42000 - 157 \frac{l}{k}.$$

$$\text{Flat ends} \dots \dots \dots \frac{l}{k} \leq 218 ; p = 42000 - 128 \frac{l}{k}.$$

MILD STEEL COLUMNS.

$$\text{Hinged ends} \dots \dots \dots \frac{l}{k} \leq 159 ; p = 52500 - 220 \frac{l}{k}.$$

$$\text{Flat ends} \dots \dots \dots \frac{l}{k} \leq 195 ; p = 52500 - 179 \frac{l}{k}.$$

CAST IRON COLUMNS.

$$\text{Hinged ends} \dots \dots \dots \frac{l}{k} \leq 09.6 ; p = 80000 - 537 \frac{l}{k}.$$

$$\text{Flat ends} \dots \dots \dots \frac{l}{k} \leq 121.6 ; p = 80000 - 438 \frac{l}{k}.$$

OAK.

$$\text{Flat ends} \dots \dots \dots \frac{l}{k} \leq 128 ; p = 5400 - 28 \frac{l}{k}.$$

A suitable factor of safety must be applied to p to get the safe working stress.

93. Columns with non-axial loads.

As stated before the line of action of the resultant load P should coincide with the axis of the column. This condition can be attained with pin joints, but when the column is fixed at the ends by large flange joints it is difficult to secure this condition of axial load.

For non-axial loads the strength of the column must be calculated by Art. 16, Chap. III.

For *short struts* we have, as in the case of a section subject to bending and thrust (Art. 16, Chap. III.),

$$f_1 = \frac{P}{A} \left(1 + \frac{x_0 x_1}{k^2} \right).$$

$$\therefore P = \frac{f_1 A}{1 + \frac{x_0 x_1}{k^2}} \dots \dots \dots (1).$$

This gives the safe load *P* for a given safe compressive stress *f*₁.
Struts of medium length.

In this case we equate the maximum compressive stress due to bending and thrust to the safe working stress got from column formula.

Thus maximum compressive stress due to bending and thrust (Art. 16, Chap. III.)

$$= \frac{P}{A} \left(1 + \frac{x_0 x_1}{k^2} \right),$$

and, by equating this to *p*, the safe working stress from column formula, we have

$$p = \frac{P}{A} \left(1 + \frac{x_0 x_1}{k^2} \right),$$

or,

$$P = \frac{pA}{1 + \frac{x_0 x_1}{k^2}} \dots \dots \dots (2).$$

This equation gives the safe load *P*, producing a given safe intensity of stress *p*.

Where *x*₀ is the distance of load *P* from centre of area

*x*₁ is the distance from centre of area of cross section to edge of section nearest the load,

k is the radius of gyration about an axis through the centre of area, perpendicular to the plane containing the centre of the area and the centre of pressure (point of application of load), as in Art. 16, Chap. III.

EXAMPLE.

A strut 12 feet long is of T-section 6" × 4" × ½". Find the safe load it will carry (a) if the load is axial, (b) if the load acts 1½ inch from the centre of area on opposite side to flange and on the central axis YY. Fig. 131.

Take both ends as fixed.

$$k_{XX} = 1.13; \quad k_{YY} = 1.35.$$

$$A = 4.75 \text{ sq. in.}$$

Distance of centre of area from upper edge of flange = 0.97 in.

CASE (a). Least $k = 1.13$.

$$p = \frac{P}{A} = \frac{f}{1 + \frac{1}{30000} \left(\frac{l}{k}\right)^2}$$

$$= \frac{6}{1 + \frac{1}{30000} \left(\frac{144}{1.13}\right)^2}$$

$$= 3.9 \text{ tons per sq. in.}$$

Hence safe load

$$P = 3.9 \times 4.75 = 18\frac{1}{2} \text{ tons.}$$

CASE (b).—In this case the point of application of load is on the axis YY . Hence we must use in our calculation k_{XX} , being the radius of gyration about axis through centre of area, perpendicular to the plane containing centre of area and point of application of load.

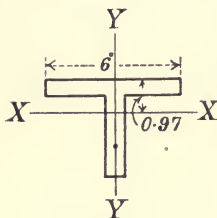

Fig. 131.

Since $k_{XX} = 1.13$, therefore, as before,

$$p = 3.9 \text{ tons per sq. in.}$$

Also $x_0 = 1\frac{1}{2}$ in, $x_1 = 4 - 0.97 = 3.03$ in.

$$\therefore 1 + \frac{x_0 x_1}{k^2} = 1 + \frac{1\frac{1}{2} \times 3.03}{1.13^2}$$

$$= 4.5.$$

Therefore safe load from Equation (2)

$$= \frac{3.9 \times 4.75}{4.5}$$

$$= 4.1 \text{ tons.}$$

NOTE.—If the load had been non-axial, and on the axis XX , then we should *first* have had to find p , using k_{YY} as this is now the radius of gyration about axis perpendicular to the plane containing centre of area and load—*then using this new value of p and k_{YY} .*

$$\text{Safe load} = \frac{pA}{1 + \frac{x_0 x_1}{k^2}}$$

CHAPTER XIV.

ARCHED RIBS AND BRACED ARCHES.

94. Steel arched ribs.

Steel arches are subdivided into two classes, *i.e.* (*a*) the unbraced or rigid arch, consisting of two flanges with a solid web like a plate girder; and (*b*) the braced arch, consisting of two chords or ribs braced together by lattice bracing.

95. Curve of pressures or linear arch.

Suspended and arch systems.—When a chain hangs under a distributed load of uniform intensity per unit of span it assumes the shape of a parabola, similar to that of the bending moment curve for a beam or girder similarly loaded. There is a *tension* at each point of the chain, the horizontal component of which is constant. Further, if the load, instead of being uniformly distributed, consists of a series of loads hanging at intervals the chain will take up a shape corresponding to the bending moment diagram, and the bending moment at any point is proportional to the depth of the chain below the line of supports.

If, now, we suppose the chain inverted and stiffened we get an arch, and the same principles apply except that we have *compression* or thrust at each point of the arch instead of tension.

The curve of pressure is the curve to which the resultant pressure at each point is tangential. It is a funicular polygon of the forces which act on the arch, and is the bending moment curve drawn to a definite scale for a similarly loaded horizontal beam of the same span.

If the curve of pressure or linear arch coincides with the axis of the rib, the thrust on any normal cross section is axial, and consequently of uniform intensity.

But the arch being incapable of adjusting itself to the bending moment curve for variable loading, there is bending produced where the curve of pressures does not coincide with the axis of

arch, and at these sections we have a bending moment and shearing stress, as well as a thrust.

An arched rib should be hinged at the springings and the crown in order to provide for its expansion and contraction due to changes of temperature. If the rib is not hinged it will undergo bending stresses due to each change of temperature. In the two hinged arch the hinges are placed at the supports only.

96. Bending moment and thrust in an arched rib.

Vertical loads.—Consider an arched rib hinged at the crown and the abutments. If the load be uniformly distributed, the curve of equilibrium or funicular polygon will be a parabola which must pass through the hinges at crown and springings. If, in addition to this uniform load, the arch be subjected to the action of a live load, the equilibrium curve or curve of pressures will be altered. Let $ADCB$ (Fig. 132) be the axis of rib; it should

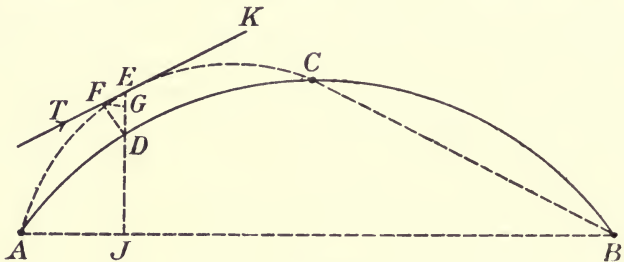

Fig. 132.

be a parabolic curve as representing the equilibrium curve for a uniform load. Let the rib be hinged at A , B , and C .

Under the uniform load the curve of pressures coincides with the axis of rib, and the thrust on any cross section is axial and of uniform intensity. Now, if the right half of arch is acted on by a live load, the curve of pressures will assume some such position $AECB$, and the only points at which the thrust is axial are A , C , and B . At all other sections of the arch there is a bending moment as well as a thrust.

Draw a vertical line JDE , cutting the axis of the rib at D and the curve of pressure at E .

Draw EK a tangent at E to the curve of pressure, and call T the thrust at E , its line of action being along the tangent EK . Draw DF perpendicular to the tangent EK and FG perpendicular to DE .

Then T at E is equivalent to a parallel force T at D and a couple whose moment is

$$M = T \times DF.$$

The horizontal component of T is

$$H = T \cos FDE = T \frac{DF}{DE}.$$

Therefore $M = T \times DF = H \times DE = H(JE - JD)$.

Thus the bending moment at D is equal to the constant horizontal component of thrust multiplied by the vertical intercept between the axis of rib and the curve of pressure at that point.

This formula is perfectly general, and applies whether the arched rib is hinged or not hinged.

Again, the force T at D (the centre of area of the cross section of rib) may be resolved into components parallel and perpendicular to the normal section at D ; the parallel component is the shearing stress; the perpendicular component produces a uniform compressive stress which has to be combined with the stress due to bending moment. Thus the thrust, shear, and bending moment at any section are easily found when the funicular has been drawn.

EXAMPLE.

A semi-circular arched rib, hinged at the crown and springing, carries a uniform load of w lbs. per foot of horizontal length. Find the position and value of the maximum bending moment.

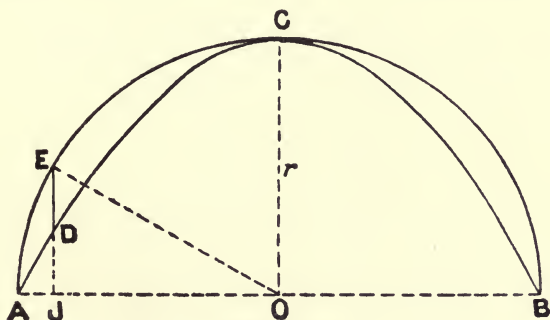

Fig. 133.

In Fig. 133 let $AECB$ be the axis of the circular rib of radius r . The load being uniform, the line of pressures will be the parabola $ADCB$, passing through the hinges A , C , and B . It has been shown that the bending moment at any point E of the rib is

$$M = H \times DE$$

where H is the horizontal thrust.

In order to find the maximum bending moment it is first necessary to determine the maximum value of DE .

Take O the centre of circle as origin, and let us find the value of x (OJ) for which ED is a maximum.

$$\text{Now,} \quad \begin{aligned} JE &= \sqrt{r^2 - x^2}, \\ JD &= r \left(1 - \frac{x^2}{r^2}\right). \end{aligned}$$

$$\text{Therefore} \quad DE = \sqrt{r^2 - x^2} - \frac{1}{r}(r^2 - x^2).$$

Differentiating and equating to zero for a maximum,

$$\frac{-x}{\sqrt{r^2 - x^2}} + \frac{2x}{r} = 0,$$

$$\frac{1}{r^2 - x^2} = \frac{4}{r^2},$$

$$x = \frac{r\sqrt{3}}{2}.$$

Substituting in the equation for DE we get

$$\text{Max. } DE = \frac{r}{4}.$$

The direction of the thrust T at A is a tangent to the parabola at that point. This tangent can be at once got by producing OC to a point K , making $CK = CO$, and then joining KA . Now as $OC = OA = r$, the tangent at A makes an angle θ with the horizontal AO such that

$$\tan \theta = \frac{2r}{r} = 2,$$

$$\text{and} \quad \sin \theta = \frac{2}{\sqrt{5}}; \quad \cos \theta = \frac{1}{\sqrt{5}}.$$

$$\text{Resolving vertically, } \frac{2}{\sqrt{5}} T = wr,$$

$$\text{therefore} \quad T = \frac{wr\sqrt{5}}{2}.$$

Horizontal thrust

$$H = T \cos \theta = \frac{wr\sqrt{5}}{2} \cdot \frac{1}{\sqrt{5}} = \frac{wr}{2} = \frac{W}{4},$$

where W = total weight on the arch.

Therefore maximum bending moment

$$= H \times \text{max. } DE = \frac{wr}{2} \cdot \frac{r}{4} = \frac{wr^2}{8}.$$

97. Arch with three hinges. Loads vertical.

The hinges are placed at the ends and at the crown. At these three points the bending moment is zero, therefore the linear arch passes through the centre of each hinge.

In Fig. 134 let ACB be the rib, hinged at A , B , and C , and suppose W the load acting at a distance x from A , the left support. Then, since there is no load on BC , the pressure at C and the reaction R_1 at B must be equal and opposite, their lines of action being along BC . Join BC and produce it to meet the line of action of W in D , join AD ; this must be the line of action of the other reaction R_2 at A . These reactions may be found graphically by taking the vertical PQ to represent W , and drawing lines PO and QO parallel respectively to R_1 and R_2 . If OS be drawn horizontal, we get H the horizontal component, and V_1 , V_2 ,

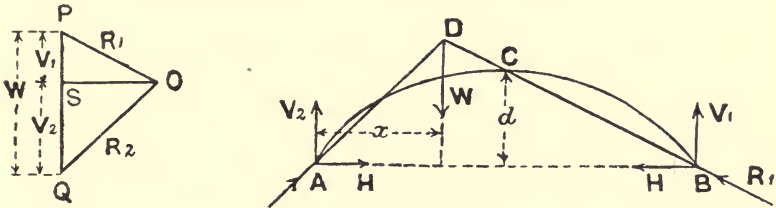

Fig. 134.

the vertical components of R_1 and R_2 . The load being vertical the horizontal components of the two reactions must be equal.

Let V_1 and V_2 be the vertical components. Then if $l = \text{span}$

$$\begin{aligned} V_1 + V_2 &= W, \\ V_2 l - W(l - x) &= 0, \\ V_2 \frac{l}{2} - Hd - W\left(\frac{l}{2} - x\right) &= 0, \end{aligned}$$

where H is the horizontal component and d the rise of arch at the crown.

From these equations

$$\begin{aligned} V_2 &= \frac{W(l-x)}{l}, \\ V_1 &= \frac{Wx}{l}, \\ H &= \frac{Wx}{2d}. \end{aligned}$$

The values of V_1 and V_2 are the same as the vertical reactions for a horizontal girder of the same span loaded in the same way.

The reactions due to a number of loads can be found by adding together the respective values of V_1 , V_2 , and H found for each load, or they may be found graphically. When the reactions have been obtained, the stresses in the different members may be found either analytically or graphically as in the case of an ordinary truss.

98. Professor Ewing gives the following method for finding the bending moments :—

The linear arch must pass through the centre of each hinge. Draw the axis of rib, then draw the bending moment diagram for the given loads considered as acting on a beam of span AB . If this diagram passes through the third hinge, it is the true linear arch; if not, alter the scale of the bending moment diagram, drawn on the base AB , so as to make it pass through C the third hinge. This can be done by first drawing it to any scale, and then reducing all the ordinates in the ratio of the central height of axis of rib to the central ordinate of the bending moment diagram.

The linear arch having been thus drawn, the vertical distance between it and the axis of rib gives on the same scale the bending moment. The thrust T is found from the known form of the linear arch and the known values of the loads. Thus the stress at any section of the rib is found. The loads may be symmetrical or unsymmetrical.

This method may also be applied to the case of a chain with hinged stiffening girder.

99. Braced arches.

The braced arch is usually one of two types—(a) The trusses are spandril braced with horizontal top chord which carries the roadway, and a parabolic rib, as in Fig. 135 (a). This is the form of steel arch bridge built at Clifton, Niagara. Span 840 feet. (b) The upper chord is horizontal and carries the roadway, the lower chord is curved (usually parabolic), and the chords are connected by vertical and diagonal bracing, Fig. 135 (b). This is the form of the Zambesi arched bridge built near the Victoria Falls. Span 500 feet.

Usually braced arched bridges are built with 3 hinges, viz. hinges at each abutment and at the crown. When hinged at the crown, the hinge is placed in the lower chord.

Three hinges are used as the stresses are more easily and more accurately obtained, and temperature stresses are eliminated; but in the two large arched bridges above mentioned, the Clifton bridge and the Zambesi bridge, only two hinges were used, one at

each abutment, probably to ensure more lateral stability and rigidity.

With regard to the stresses, it has already been shown in the chapter on parabolic girders that for a uniform dead load there is no stress in the bracing, so that the bracing between the two chords of the arch, as in the Clifton bridge type (a), or between the parabolic chord and horizontal member, as in the Zambesi bridge type (b), is only affected by the live load.

100. Stresses in a braced arch with three hinges.

In Art. 97 it was explained how to obtain the abutment reactions for a single load W . It was there shown that if a and b (Fig. 134) are the hinges at the abutments, and if a single

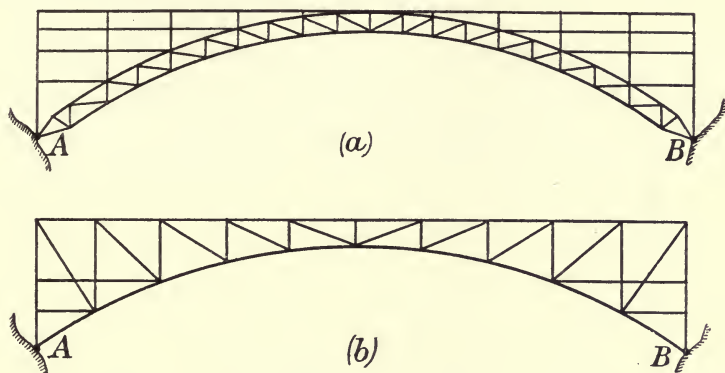

Fig. 135.

load W is placed at a panel point distant x from a , then the vertical components of the reactions are

$$V_a = \frac{W(l-x)}{l}; \quad V_b = \frac{Wx}{l}.$$

And the horizontal components are each equal to

$$H = \frac{Wx}{2d}.$$

When these reactions are known we can find the stresses due to W in each member. If we perform the same operation for each weight, and tabulate the stresses, we can determine the maximum stresses of each kind produced in every member of the arch, or more simply we can find the reactions at the abutments and determine the stresses graphically from the stress diagram.

Example.—Let Fig. 136 represent a steel braced arch 160 feet span, divided into 8 panels, each 20 feet long. It carries a dead

load of 12 tons at each panel point. The arch is hinged at the crown and abutments. Find the stresses in each member of the arch. The lower or curved chord is *not* parabolic. An example of a similar braced arch with parabolic lower chord is given in Art. 102.

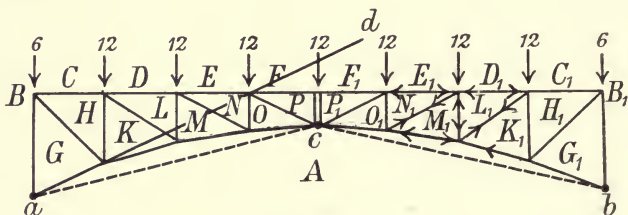

Fig. 136.

The half panel loads B_1C_1 and BC may be omitted, and at the end add a half panel load to the compression in each end vertical. The total load omitting these is 84 tons. Draw a vertical line (Fig. 137) and on it set off C_1C to represent 84 tons; then starting from C_1 mark off $C_1D_1, D_1E_1, \dots DC$, each equal to 12 tons.

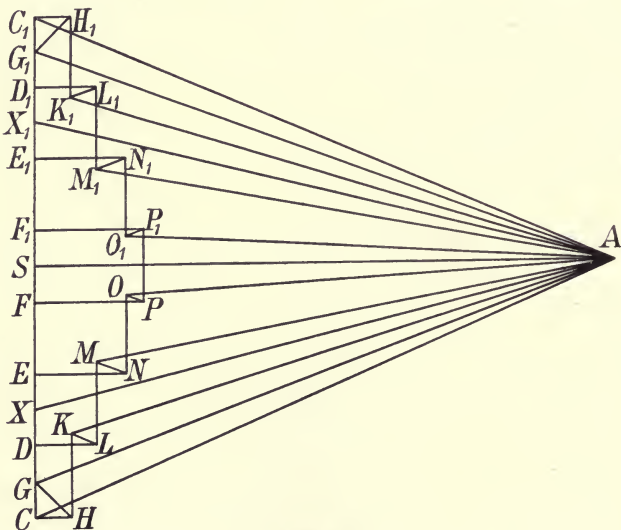

Fig. 137.

Now each half of the arch is loaded with 42 tons. Considering the left half of arch, the proportion of this vertical load carried by the abutment at a is 18 tons, and at the crown c , 24 tons. Similarly for the right hand half of the arch we have the

vertical reaction at $b = 18$ tons, and at the crown c , 24 tons. Hence, from C_1 mark off $C_1X_1 = 18$ tons, $X_1X = 48$ tons, and $XC = 18$ tons.

From X_1 and X draw lines parallel to bc and ac (Fig. 137), then A is the pole and AX_1 represents the reaction of right half of arch on left half, and XA that of the left half of arch on the right half. Join C_1A and CA , then C_1A is the resultant reaction at the right abutment b , and CA is the resultant reaction at the left abutment a . The horizontal line AS is the horizontal component H of the reactions at the abutments, and also the stress on the hinge at crown of arch. Having found the abutment reactions the stresses are got by the stress diagram (Fig. 137).

101. Stresses obtained by moments.

The stresses in the braced arch may be obtained by moments when the abutment reactions have been found. As an example let it be required to check the stresses in members EN and AM (Fig. 136) as found from the stress diagram.

Through a (Fig. 136) draw ad parallel to CA (Fig. 137), then ad represents the direction of the abutment reaction at a .

To find the stress in EN.—Take moments about the intersection of MN and MA (Fig. 136). Consider the equilibrium of the portion of arch to left of NO . The external forces acting on it are the abutment reaction at a , equal to 108 tons, and the two vertical loads CD and DE , each equal to 12 tons. (The half panel load was omitted in stress diagram.)

The perpendicular arm from abutment reaction to centre of moments is 8.2 feet, and NO equals 10 feet.

Hence,

$$S_{EN} \times 10 = 108 \times 8.2 - 12(40 + 20).$$

$$S_{EN} = 16.5 \text{ tons.}$$

Stress in AM.—The centre of moments is the intersection of MN and EN .

Forces	Arm	Moment
108	8.25	891
12	20	240
S_{AM}	12.75	$S_{AM} \times 12.75$

$$S_{AM} \times 12.75 = 891 + 240 = 1131 \text{ foot tons.}$$

$$S_{AM} = 88.7 \text{ tons.}$$

These results agree closely with the stresses as found by stress diagram.

102. Live load stresses.

In order to determine the maximum tension and compression in any particular member it is first necessary to ascertain which panel points must be loaded in order to produce these maximum stresses.

CHORD MEMBERS.

Upper chord. Member cd (Fig. 138).

Consider a single load W .

Take a section YY_1 , cutting the three members cd , cD , CD . Then the point about which to take moments in order to determine the stress in cd is D , the point of intersection of the other two members.

Join AD and produce it to meet the direction of the hinge reaction R_1 (which acts in the direction MF) in o . If the vertical

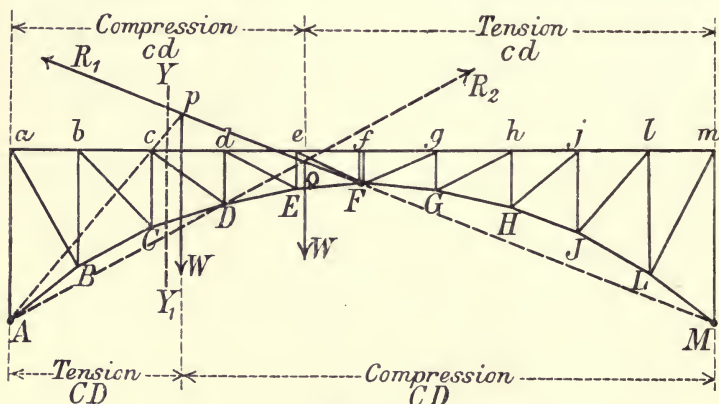

Fig. 138.

load W is placed so that its line of action passes through o , it can produce no stress in cd . For if W acts through o , it must be balanced by its reactions acting in directions Ao and Mo .

Thus, the portion of the arch YY_1F is acted on by the forces W and R_1 , which are equivalent to a single resultant R_2 acting in the direction oA which passes through D the centre of moments; consequently there is no bending moment at D and no stress in cd .

If W is placed anywhere on the right of o ; for all positions to the right of F , its effect is along R_2 in direction FA ; and for all positions between F and o along directions of R_2 lying between oA and FA , and consequently below D . The moment of the force is clockwise, tending to extend cd which is in tension.

For any position of W between YY_1 and o , the direction of

R_2 is above D , and produces a moment round D which is counter clockwise, and therefore cd is in *compression*. If W is placed to the left of YY_1 , R_1 is the resultant of W and R_2 , acting on YY_1F in direction FM , its moment round D is counter clockwise and cd is in *compression*. Thus the member cd is in *tension* for all positions of the load W to the right of o , and in *compression* for all positions of W to the left of o .

For clearness the sense of the stress in cd for different positions of the load W is shown in upper part of Fig. 138.

Lower chord. Member CD (Fig. 138).

Join A to c , the centre of moments for CD , and produce Ac to meet R_1 in p . Then, as before, if the line of action of W passes through p , there is no stress in CD , and that if W is placed in any position to the right of p , then CD is in *compression*, and if W is placed in any position to the left of p , then CD in *tension*. The maximum tensile stress in CD will be when the portion of platform from a to p is fully loaded, the portion pm being unloaded; and the maximum compressive stress in CD will be when mp is fully loaded and ap is unloaded.

It should be noticed that the panel point e , which is the centre of moments for the member EF lies on the opposite side of R_1 to the other centres of moments a, b, c, d ; consequently all loads to the left of EF will cause *compressive stress* in EF ; therefore EF will be in compression for loads at all the joints, and the maximum compression in EF will occur when the live load covers the whole platform.

For clearness the sense of the stress in CD for different positions of the load W is shown in lower part of Fig. 138.

DIAGONAL BRACES.—These should be taken separately. Consider aB and cD (Fig. 139).

Diagonal brace aB.—Take a vertical section cutting the three members ab, aB, AB ; then the centre of moments for aB is S_1 , the intersection of ab and AB . Produce AS_1 , to meet R_1 in P_1 ; if the line of action of W passes through P_1 , there can be no moment about S_1 and no stress in aB .

If W is placed on the right of F , the resultant of W and R_1 will be in direction FA , and if placed between F and P_1 the resultant will be in some direction between FA and P_1A , in either case it passes below S_1 , produces a clockwise moment, and causes compression in aB .

If W is placed between P_1 and the vertical section cutting ab , the resultant R_2 must pass above S_1 , its moment is counter clockwise, causing *tension* in aB . The sense of the stress in diagonal aB for different positions of the load W is shown in upper part of Fig. 139.

Diagonal brace cD.—The centre of moments is S_3 ; P_3 is the intersection of S_3A with R_1 . If the load W is placed anywhere to the right of P_3 it must as above cause *compression* in cD , and if placed between P_3 and the section YY_1 will cause *tension* in cD . When the load is placed to the left of YY_1 the resultant force on YY_1F is R_1 , and as its direction passes below S_3 its moment is clockwise and causes *compression* in cD .

There are thus two points where the stress changes, one at P_3 , the other between c and d . The sense of the stress in cD is shown in upper part of Fig. 139 for different positions of the load W .

Thus, the *maximum tension* in diagonal cD occurs when the portion of platform between section YY_1 and P_3 is loaded, the

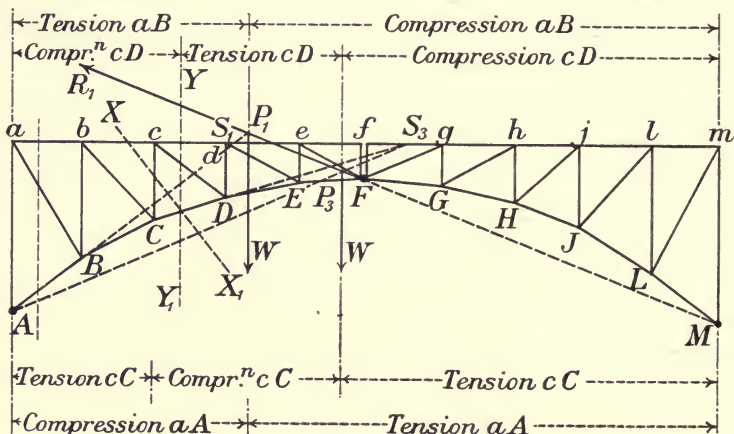

Fig. 139.

remainder of the span being unloaded; and the *maximum compression* in cD occurs when the whole span is loaded with the exception of the portion between YY_1 and P_3 , which should be unloaded.

For some of the diagonals near centre the point P may fall below the hinge F , in which case P is no longer a point of division between loads which produce stresses of opposite sense, and the section YY_1 alone marks the division.

VERTICALS.—The section taken, XX_1 , must be inclined so as to cut the vertical. The centres of moments and the load limits are the same for the vertical and the diagonal brace which meet at the top chord, such as cC and cD . The loading that produces compression in a diagonal brace produces tension in the vertical, and *vice versa*.

The sense of the stress in verticals aA and cC corresponding to the position of load W is shown in lower part of Fig. 139.

EXAMPLE.

A braced steel arch, as in Fig. 140, is hinged at the crown and the two abutments. The span is 150 feet, and the rise 30 feet. The top chord is horizontal, and is divided into 10 equal bay lengths of 15 feet. The lower chord is parabolic, and is connected to the upper horizontal chord by vertical and diagonal bracing. The depth of central vertical is 6 feet, and that of the end verticals 36 feet.

If the dead load per panel is 35 tons, and the live load per panel is 15 tons, determine the stresses in cd , CD , cD , and cC .

Tensile stresses are denoted by negative sign and compressive stresses by positive sign. The half panel loads at a and m may be omitted, as they are carried direct by the end verticals. Having found the stresses in all the members, add a half panel load to the compression in each end vertical.

Reactions.—As in Art. 102 it was shown that the maximum tension and compression in members is produced by different loadings, it is convenient to first make a tabular statement of the vertical and horizontal components of the reaction at the left abutment due to live load at each panel point separately.

Vertical and Horizontal Reactions at A		
Load at	V_a	$H = \frac{Wx}{2d}$
	Tons	Tons
l . . .	$\frac{1 \times 15}{10} = 1.5$	$\frac{15 \times 15}{60} = 3.75$
k . . .	$2 \times 1.5 = 3.0$	$2 \times 3.75 = 7.50$
h . . .	$3 \times 1.5 = 4.5$	$3 \times 3.75 = 11.25$
g . . .	$4 \times 1.5 = 6.0$	$4 \times 3.75 = 15.00$
f . . .	$5 \times 1.5 = 7.5$	$5 \times 3.75 = 18.75$
e . . .	$6 \times 1.5 = 9.0$	$4 \times 3.75 = 15.00$
d . . .	$7 \times 1.5 = 10.5$	$3 \times 3.75 = 11.25$
c . . .	$8 \times 1.5 = 12.0$	$2 \times 3.75 = 7.50$
b . . .	$9 \times 1.5 = 13.5$	$1 \times 3.75 = 3.75$
All joints loaded	67.5	93.75

LIVE LOAD.—STRESSES IN UPPER CHORD MEMBER cd .

Maximum tension.—According to Art. 102 (Fig. 138) the maximum tension in cd occurs when the joints f to l are loaded with live load, the other joints being unloaded.

Therefore $V_a = 1.5 + 3.0 + 4.5 + 6.0 + 7.5 = 22.5$ tons,
 and $H = 3.75 + 7.50 + 11.25 + 15.00 + 18.75 = 56.25$ tons.

Considering the forces to the left of the section YY cutting *cd*, *cD*, and *CD*, and taking moments about *D*, we have

$$S_{cd} \times 10.8 = 22.5 \times 45 - 56.25 \times 25.2 = -405.0.$$

$$\therefore S_{cd} = -37.5 \text{ tons tension} \dots\dots\dots(1).$$

Maximum compression.—The maximum compression in *cd* occurs when joints *b* to *e* are loaded with the live load, the other joints being unloaded (Art. 102, Fig. 138).

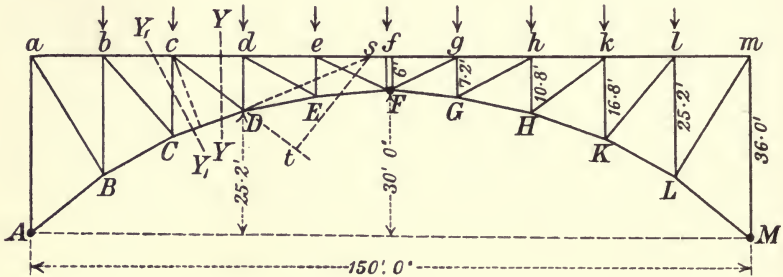

Fig. 140.

For this loading

$$V_a = 9.0 + 10.5 + 12.0 + 13.5 = 45 \text{ tons.}$$

$$H = 15.00 + 11.25 + 7.50 + 3.75 = 37.5 \text{ tons.}$$

Taking moments about the lower joint *D*,

$$S_{cd} \times 10.8 = 45 \times 45 - 37.5 \times 25.2 - 15(30 + 15) = 2025 - 945 - 675 = +405.$$

$$\therefore S_{cd} = +37.5 \text{ tons compression} \dots\dots\dots(2).$$

From (1) and (2) we see that the sum of the maximum tension and maximum compression is zero, therefore when *all* the joints are loaded with the live load the stress in *cd* is zero, and consequently the *dead load stress is also zero* as all the joints are loaded with the dead load.

DIAGONAL *cD*.

Maximum tension.—By Art. 102 (Fig. 139) the maximum tension in *cD* occurs when joints *d* and *e* are loaded.

Hence $V_a = 9 + 10.5 = 19.5$ tons,
 and $H = 15.00 + 11.25 = 26.25$ tons.

Moments must be taken about s , the intersection of cd and CD (Fig. 140).

By proportion we find $ds = 27$ feet, therefore $as = 72$ feet.

To find st the perpendicular from s to cD , the angle dcD is

$$\tan^{-1} \frac{10.8}{15} = \theta, \text{ say,}$$

then $st = 42 \sin \theta = 24.5$ feet.

Taking moments of the forces on left of the section YY about s , we have

$$S_{cd} \times 24.5 = 26.25 \times 36 - 19.5 \times 72 \\ = -468.$$

$$\therefore S_{cd} = -19.1 \text{ tons tension} \dots\dots\dots(3).$$

Maximum compression.—The maximum compression in diagonal cD occurs when joints b, c, f, g, h, k , and l are loaded (Fig. 139).

Hence $V_1 = 13.5 + 12.0 + 7.5 + 6.0 + 4.5 + 3.0 + 1.5 \\ = 48$ tons,

and $H = 3.75 + 7.50 + 18.75 + 15.00 + 11.25 + 7.50 + 3.75 \\ = 67.5$ tons.

Taking moments as before about s (Fig. 140),

$$S_{cd} \times 24.5 = 67.5 \times 36 - 48 \times 72 + 15(57 + 42) \\ = 2430 - 3456 + 1485 \\ = +459.$$

$$\therefore S_{cd} = +18.7 \text{ tons compression} \dots\dots\dots(4).$$

From (3) and (4) we see that when all the joints are loaded with the live load there is no stress in the diagonal cD , and consequently the dead load stress in diagonal cD is zero.

LOWER CHORD. MEMBER CD .

From Art. 102 (Fig. 138), the maximum compression in CD occurs when joints d to l are loaded and from table of reactions we have as before

$$V_a = 42 \text{ tons, and } H = 82.5 \text{ tons.}$$

The perpendicular arm from c on $CD = 15.6$ feet.

Taking moments of the forces on left of section YY about c , the intersection of cd and cD , we get

$$S_{cd} \times 15.6 = 82.5 \times 36 - 42 \times 30 \\ = +1710.$$

$$\therefore S_{cd} = +109.6 \text{ tons compression} \dots\dots\dots(5).$$

The maximum tension in CD occurs when joints b and c are loaded, in which case

$$V_a = 25.5 \text{ tons, and } H = 11.25 \text{ tons.}$$

Taking moments as before about c ,

$$\begin{aligned} S_{CD} \times 15.6 &= 11.25 \times 36 - 25.5 \times 30 + 15 \times 15 \\ &= 405 - 765 + 225 \\ &= -135. \end{aligned}$$

$$\therefore S_{CD} = -8.6 \text{ tons tension} \dots \dots \dots (6).$$

When all the joints are loaded with the live load, the maximum stress in lower chord member CD is from 5 and 6,

$$+109.6 - 8.6 = +101 \text{ tons compression} \dots \dots \dots (7).$$

Check.—When all the joints are loaded with live load we have seen that there is no stress in the diagonals; consequently the horizontal component of stress in any member of the parabolic or lower chord is equal to H .

Therefore $S_{CD} = H \sec \beta$

where β = angle that the member CD makes with the horizontal,

$$\text{but } \tan \beta = \frac{10.8}{27}, \text{ hence } \sec \beta = 1.076,$$

$$\text{and } H \text{ from table of reactions} = 93.75 \text{ tons.}$$

Therefore $S_{CD} = 93.75 \times 1.076 = +101$ tons compression, which is the same value as in Equation (7).

Dead load stress.—The dead load stress in lower member CD can be found at once from above, since the ratio of dead load to live loads is $\frac{3.5}{15} = \frac{7}{3}$.

$$\begin{aligned} \text{Hence, dead load stress in } CD &= \frac{7}{3} \times 101 \\ &= +232 \text{ tons compression.} \end{aligned}$$

$$\begin{aligned} \text{Therefore maximum stress in } CD &= 232 + 109.6 \\ &= 341.6 \text{ tons compression.} \end{aligned}$$

$$\begin{aligned} \text{Minimum stress in } CD &= 232 - 8.6 \\ &= 223.4 \text{ tons compression.} \end{aligned}$$

VERTICAL cC .

Consider the inclined section Y_1Y_1 cutting bc , cC , and CD . As explained in Art. 102 (Fig. 139) the maximum compression in vertical cC occurs when the joints c , d , and e are loaded.

From table of reactions we get for this loading,

$$V_a = 31.5, \text{ and } H = 33.75 \text{ tons.}$$

Taking moments about s of the forces on left of section,

$$\begin{aligned} S_{cC} \times 42 &= 31.5 \times 72 - 33.75 \times 36 \\ &= +1053. \end{aligned}$$

$$\therefore S_{cC} = +25.07 \text{ tons compression} \dots \dots \dots (8).$$

The maximum tension in vertical cC occurs when the joints b , f , g , h , k , and l are loaded (Art. 102, Fig. 139).

From table of reactions

$$V_a = 36 \text{ tons, and } H = 60 \text{ tons.}$$

Taking moments round s , we get

$$\begin{aligned} S_{cC} \times 42 &= 36 \times 72 - 60 \times 36 - 15 \times 57 \\ &= 2592 - 2160 - 855 \\ &= -423. \end{aligned}$$

$$\therefore S_{cC} = -10.07 \text{ tons tension} \dots \dots \dots (9).$$

From (8) and (9) we see that when *all the joints are loaded* with live load the stress in vertical cC is

$$\begin{aligned} &+ 25.07 - 10.07 \\ &= +15 \text{ tons compression,} \end{aligned}$$

which is equal to the panel load.

Dead load stress.

It follows that the dead load stress in vertical must be equal to the dead panel load—that is, 35 tons compression.

Therefore maximum stress in vertical cC is

$$+ 35 + 25.07 = + 60.07 \text{ tons compression,}$$

and minimum stress in vertical cC is

$$+ 35 - 10.07 = + 24.93 \text{ tons compression.}$$

103. Parabolic arch rib, hinged at ends.

A steel arch rib is a girder in the form of an arch, with the radial depth usually constant. The chords, consisting of plates and angles, are connected either by a continuous plate web or by vertical and diagonal bracing.

The Niagara and Clifton steel arch, already alluded to, is an example of this class of structure. The span is 840 feet and the rise 150 feet to centre of arch, depth 26 feet. The two parallel chords are connected by vertical and diagonal bracing.

The following method is due to Professor Charles E. Greene, and for fuller details the reader is referred to his book on 'Trusses and Arches Analysed and Discussed by Graphical Methods,' and 'Higher Structures,' by Merriman and Jacoby.

In Fig. 141 A and B are the hinged ends. AHB the axis of rib.

Consider a single load W , distant OG from the centre of span.

Let c = the half span = OB .

„ k = rise of arch.

„ b = $OG = nc$, a fraction of the half span.

„ y_o = ordinate to the load polygon at point of application of load W .

In the case of the three-hinged arch, the reactions pass through the abutment hinges and the hinge at crown. But in the case of the two-hinged arch the reactions pass through the abutment hinges and the locus of the point C , the intersection of the directions of the reactions for a load placed at any point.

The locus of the point C is found from the equation

$$y_o = \frac{32}{c} k \frac{c^2}{5c^2 - b^2}, \text{ and since } b = nc$$

$$= \frac{32}{5(5 - n^2)} k \dots \dots \dots (1).$$

This formula is applicable to points on either side of the centre O . From (1) the locus curve of C can be plotted, and the directions of the reactions found graphically for W at any point

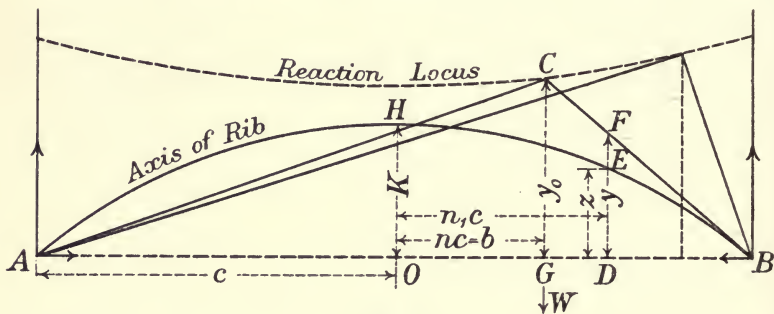

Fig. 141.

by connecting the abutment hinges with the point where the line of action of W cuts the curve.

At the centre $b = 0, y_o = \frac{32}{5} k.$

At the ends $b = c, y_o = \frac{32}{0} k.$

Horizontal thrust.—The horizontal thrust at each hinge must be the same, since the sum of the horizontal forces acting on the arch must be zero. Taking moments about B and A,

$$V_A = \frac{W(c-b)}{2c}; V_B = \frac{W(c+b)}{2c} \dots \dots \dots (2),$$

but $\frac{H}{V_A} = \frac{c+b}{y_o}.$

Therefore $H = V_A \frac{c+b}{y_o} = W \frac{c^2 - b^2}{2cy}$

or substituting for y_o its value in (1)

$$H = \frac{1 - n^2}{2} \cdot \frac{5(5 - n^2)}{32} \cdot \frac{c}{k} W \dots \dots \dots (3).$$

H being the horizontal thrust at abutment due to any load W placed at a distance, nc , from the centre of span.

The formula applies to a load placed on either side of the centre.

From Equations (2) and (3) the components of the reactions due to each load can be found, and the results added for those loads which acting together cause a maximum stress in any given member. The stresses in the member can then be found by taking moments of the forces on one side of the section cutting it.

Bending moments.

It has been shown in Art. 96 that

$$M = H(y-z) \dots\dots\dots(4).$$

Where in this case

M = bending moment at any point of span, due to a load W distant nc from centre of span.

y = ordinate DF to inclined line of load polygon at point of bending moment M .

z = ordinate DE to axis of arch at point of bending moment M , n_1c from centre of span.

Having found y_0 from Equation (1), the values of y can be obtained by proportion. The ordinate z is proportional to the product of the segments into which it divides the span.

$$z = (1 + n_1) c (1 - n_1) c \frac{k}{c^2}$$

$$= (1 - n_1^2) k \dots\dots\dots(5).$$

Temperature stresses.

A change of temperature affects values of H , but not of V_A or V_B . The arch is usually designed for some standard temperature.

If e is the coefficient of expansion,

t° is the rise of temperature above standard ;

then
$$H_t = \frac{15 EI_c t e}{8 k^2} \dots\dots\dots(6).$$

For a fall of t° in temperature, t is negative and H outward.

$$H_t = - \frac{15 EI_c t e}{8 k^2} \dots\dots\dots(7).$$

here I_c = Moment of Inertia at crown.

104. Example of parabolic arched rib.

Fig. 142 represents a parabolic arched rib 150 feet span, 30 feet rise, divided into 10 equal panel lengths of 15 feet each. The dead load is 32 tons per panel, and the live load 16 tons per panel.

Live load.

Determination of y_0 and H .

To plot the reaction locus it is necessary to find the different values of the ordinate y_0 for different positions of panel load by

Equation (1). Then get H from Equation (3). It is only necessary to calculate y_0 and H for half the span, as at corresponding points equally distant from the centre they have the same values, since n^2 is positive whether n is positive or negative.

Live panel load $W = 16$ tons ; $\frac{c}{k} W$ (Equation (3)) = 40 ; $k = 30$.

Table I.

Position of W	$n = \frac{b}{c}$	$\frac{32}{5(5-n^2)}$ = $y_0 \div k$	y_0	$\frac{1-n^2}{2} \cdot \frac{5(5-n^2)}{32}$	$\frac{c}{k} W$	H
At 1 or 9	0.8	1.468	44.04	0.123	40	4.92
2 or 8	0.6	1.379	41.38	0.232		9.28
3 or 7	0.4	1.322	39.67	0.318		12.72
4 or 6	0.2	1.293	38.80	0.372		14.88
5	0	1.280	38.40	0.391		15.64

$$y_0 \text{ at ends} = \frac{32}{20} \cdot 30 = 48.$$

The ordinates y_0 are plotted in Fig. 142 from the line AB , and the dotted curve LM thus obtained is the reaction locus.

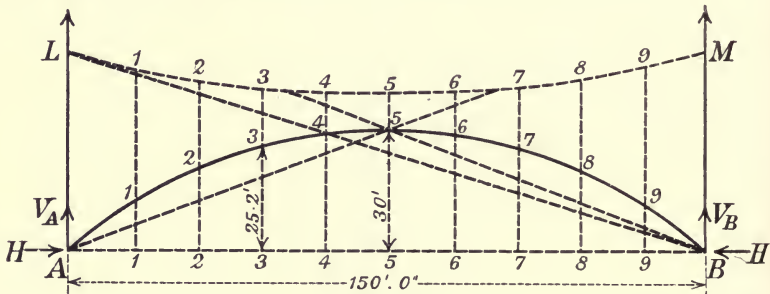

Fig. 142.

When all the panel points are loaded with live load
 $H = \{ 15.64 + 2(14.88 + 12.72 + 9.28 + 4.92) \}$
 $= 99.24$ tons.

As the dead panel load is double the live panel load,
 The horizontal component of reaction due to dead load is
 $H = 198.48$ tons.

Bending moments.

$$M = H(y - z) = kH \left(\frac{y}{k} - \frac{z}{k} \right).$$

To find y and z the panel load must be placed at each point of division and for convenience of reference a table made.

$\frac{y}{k}$ is got at once by proportion from $\frac{y_0}{k}$; thus, if the load is at division 6, the load polygon being a triangle $\frac{y}{k}$ will be successively from the left $\frac{1}{6}, \frac{2}{6}, \frac{3}{6} \dots$ of $\frac{y_0}{k}$; and from the right $\frac{1}{4}, \frac{2}{4} \dots$ of $\frac{y_0}{k}$.

From (5) $\frac{z}{k} = (1 - n_1^2)$, where $n_1 c$ is the distance of ordinate z from the centre.

To exemplify the method of determining the bending moments due to a single panel load at one division of the arch, let us find the bending moments due to $W = 16$ tons placed at division 6.

From Table I., $\frac{y_0}{k}$ at 6 = 1.293,

$$H = 14.88,$$

and

$$\therefore kH = 446.4.$$

Table II.

Values of M due to load $W = 16$ tons at division 6.

Division	$\frac{y}{k}$	n_1	$\frac{z}{k}$	$\frac{y}{k} - \frac{z}{k}$	kH	M
1	.2155	.8	.36	-.1445	..	- 64.6
2	.4310	.6	.64	-.209	..	- 93.3
3	.6465	.4	.84	-.1935	..	- 87.4
4	.8620	.2	.96	-.098	446.4	- 43.6
5	1.0775	.0	1.00	+.0775	..	+ 34.6
6	1.2930	.2	.96	+.333	..	+ 148.7
7	.9696	.4	.84	+.1296	..	+ 57.8
8	.6464	.6	.64	+.0064	..	+ 2.8
9	.3232	.8	.36	-.0368	..	- 16.5

In order to make a complete table of bending moments, which is done as in Table II. for the load at each panel point in succession, it is only necessary to take the panel load at the divisions on one side of the centre, as necessarily the load on the other side at equidistant points from the centre will give the same values but in the *reverse* order.

Table III.—Bending Moments.

—	1	2	3	4	5	6	7	8	9
W on 1	+163·2	+98·4	+44·2	+2·4	-27·4	-45·6	-51·6	-46·8	-28·8
2	+91·2	+205·2	+102·0	+20·4	-38·2	-75·6	-90·0	-81·6	-52·8
3	+30·0	+91·2	+183·4	+66·0	-21·4	-78·0	-104·4	-99·6	-64·6
4	-16·5	+2·8	+57·6	+148·7	+34·4	-43·6	-87·4	-93·3	-64·6
5	-49·2	-60·0	-33·6	+30·0	+129·8	+30·0	-33·6	-60·0	-49·2
6	-64·6	-93·3	-87·4	-43·6	+34·4	+148·7	+57·6	+2·8	-16·5
7	-64·6	-99·6	-104·4	-78·0	-21·4	+66·0	+183·4	+91·2	+30·0
8	-52·8	-81·6	-90·0	-75·6	-38·2	+20·4	+102·0	+205·2	+91·2
9	-28·8	-46·8	-51·6	-45·6	-27·4	+2·4	+44·2	+98·4	+163·2

The total bending moment at any panel point due to several loads is the sum of the partial moments at that panel point due to each load.

105. Calculation of moments from the vertical and horizontal components of reactions.

As a check on the above table of moments, or as a separate method of determining the bending moments, the following method is useful:—Referring to Fig. 142, we can find the loading which produces the maximum bending moment at any point of division by drawing lines through the hinges and the point of division. These lines produced to cut the reaction locus show at once what loads produce maximum moment. It will be seen that the line joining *B* to 4 is the first to touch the locus curve, and is tangential to it. Hence for any point of division between 1 and 4 the maximum positive bending moment is due to loads at 1, 2, 3, and 4, and the maximum negative moment is due to loads at 5, 6, 7, 8, 9.

For section 5 at the crown the maximum positive bending moment is due to loads at 4, 5, and 6; and the maximum negative moment is due to loads at 1, 2, 3, 7, 8, 9.

To determine the bending moments it is convenient first to make a table of the vertical and horizontal components of reactions for the live panel load of 16 tons.

The values of *H* are repeated from Table I.

V_A and V_B are found from Equation (2), Art. 103.

Table IV.

Load at	V_A	V_B	H
1	14.4	1.6	49.2
2	12.8	3.2	9.82
3	11.2	4.8	12.72
4	9.6	6.4	14.88
5	8.0	8.0	15.64
6	6.4	9.6	14.88
7	4.8	11.2	12.72
8	3.2	12.8	9.28
9	1.6	14.4	4.92

Division 3.—The ordinate to 3 from $AB = 25.2$ feet.

As stated before, the maximum positive bending moment at 3 occurs when points 1 to 4 are loaded with live load.

From Table IV. for this loading,

$$\begin{aligned} V_A &= 48 \text{ tons, } H = 41.8 \text{ tons.} \\ \therefore M_3 &= 48 \times 45 - 41.8 \times 25.2 - 16(1+2)15 \\ &= 2160 - 1053 - 720 \\ &= +387 \text{ foot tons.} \end{aligned}$$

To check this by table of bending moments No. III., add the bending moments in division 3 due to W on 1, 2, 3, and 4, and we get

$$M_3 = 387.2 \text{ foot tons.}$$

The maximum negative moment at 3, due to loads 5 to 9,

$$\begin{aligned} &= 24 \times 45 - 57.44 \times 25.2 \\ &= -367.4 \text{ foot tons.} \end{aligned}$$

On adding the negative moments in division 3 of Table III. we find the sum = -367 foot tons ;

when *all* the panel points are loaded with live load

$$\begin{aligned} \text{Max. } M &= 72 \times 45 - 99.24 \times 25.2 - 16 \times 45 \\ &= 20 \text{ foot tons nearly.} \end{aligned}$$

This is the difference between the maximum positive and maximum negative moments, which serves as a check.

Division 5 at crown.—As explained, the loading for maximum positive bending moment is when points 4, 5, and 6 are loaded. The corresponding components of reactions are

$$V_A = 24 \text{ tons ; } H = 45.4 \text{ tons.}$$

Hence

$$\begin{aligned} M_5 &= 24 \times 75 - 45.4 \times 30 - 16 \times 15 \\ &= +198 \text{ foot tons.} \end{aligned}$$

From Table No. III. the sum of the positive moments in division 5 for load at 4, 5, and 6 is 198.6 foot tons, which checks.

The maximum negative moment at 5 or crown is due to loads at 1, 2, 3, 7, 8, 9,

for which loading $V_A = 48$; $H = 53.8$.

$$M_5 = 48 \times 75 - 53.8 \times 30 - 16(2 + 3 + 4)15 \\ = 174 \text{ foot tons,}$$

which checks with Table No. III.

Temperature thrust.

If this arch was designed for a standard temperature of 60° and that the variation of temperature was likely to be 80° , find the maximum thrust if

$$I_c = 180000 \text{ inch units.}$$

$$e = .000007.$$

$$E = 13000 \text{ tons per sq. in.}$$

$$k = 30 \text{ feet} = 360 \text{ inches.}$$

From (6) and (7)

$$H_t = \pm \frac{15EI_c t e}{8k^2} \\ = \pm \frac{15 \times 13000 \times 180000 \times 80 \times 7}{1000000 \times 8 \times 360 \times 360} \\ = \pm 19 \text{ tons.}$$

106. Shear parabolic rib.

In the case of a hinged rib, having a parabolic curve for neutral axis, when loaded all over with a *uniform load* there is no shear in the bracing, and the thrust is tangential to the parabolic curve.

For a load W placed in any position on the rib (Fig. 143) we have (a) a vertical reaction V_1 at the left abutment, and (b) a horizontal thrust H . The vertical force that must be combined with H to have a resultant reaction tangential to parabola at abutment is evidently $H \tan \theta = H \frac{2k}{c}$.

Call this force F_1 . It corresponds to the vertical reaction at abutment due to a uniform load on a beam.

Consequently, if

V = shear at left abutment due to a load W ,

V_1 = vertical abutment reaction on the left due to load W ,

F_1 = vertical reaction at either abutment necessary to combine with horizontal thrust H , due to any load W , in order to have the resultant reaction at the abutment tangential to the parabolic rib axis,

$$V = V_1 - F_1 = W \frac{c \pm b}{2c} - \frac{2kH}{c} \dots \dots \dots (8).$$

Fig. 144 shows the shear diagram. The ordinates from AB to $CEFH$ represent the shear due to W . The ordinates to the straight line DG represent the vertical force to be combined with horizontal thrust for tangential thrust.

Example.—To determine the shear at sections *midway* between the points of division of the parabolic rib in Fig. 142 or 143.

Call W the load, so as to make the results generally applicable (in example $W = 16$ tons).

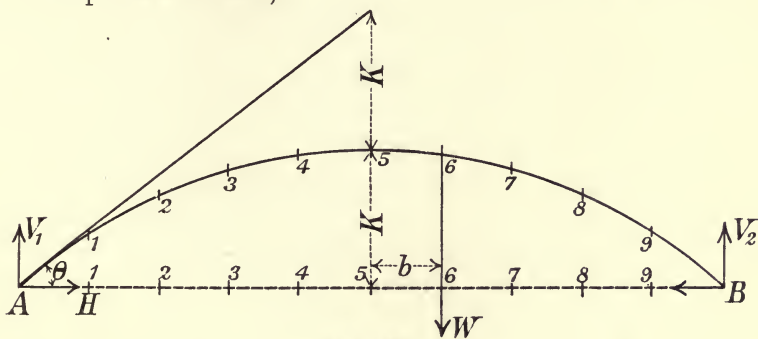

Fig. 143.

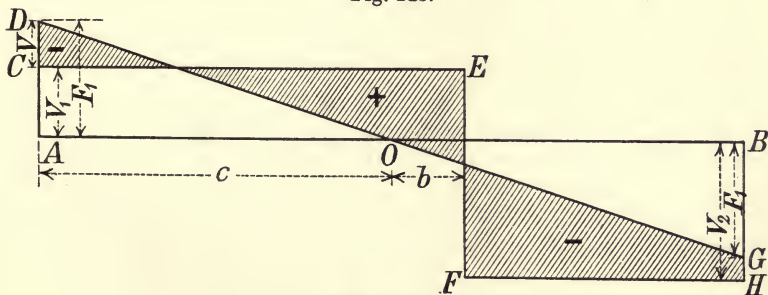

Fig. 144.

From Equation (8)

$$V = V_1 - \frac{2kH}{c}$$

Substituting for H from equation (3)

$$\begin{aligned} V &= V_1 - \frac{2k}{c} \left\{ \frac{1-n^2}{2} \cdot \frac{5(5-n^2)}{32} \right\} \frac{c}{k} W \\ &= V_1 - 2 \left\{ \frac{1-n^2}{2} \cdot \frac{5(5-n^2)}{32} \right\} W. \end{aligned}$$

The values of $\frac{1-n^2}{2} \cdot \frac{5(5-n)^2}{32}$ are given in Table I.

The details of calculation for W at division 6 will be given. For

W at other points the calculation will be similar. Table V. gives the final results for W at each point of division. It will be seen that the calculations need only be made for half the span. The figures for the other half being the same, but in *reverse* order with opposite sign. Having found F_1 at the ends, F at any other point can be got from the slope of the inclined uniform shear line which passes through the centre of span.

For W at division 6,

$$V_1 = 0.4W ; V_2 = 0.6W.$$

From Table I. $H = 0.372 \frac{c}{k} W$.

$$\therefore F_1 = 2 \times 0.372W \\ = 0.744 W.$$

F at middle of first division, $A-1 = \frac{9}{10} F_1 = 0.67$.

Each succeeding ordinate at mid-division diminishes by

$$\frac{F_1}{5} = \frac{0.744W}{5} = 0.149W.$$

Values of V for W at division 6.

Mid. space	1	2	3	4	5	6	7	8	9	10	—
V_1	+·4	+·4	+·4	+·4	+·4	+·4	-·6	-·6	-·6	-·6	$\times W$
F	+·67	+·52	+·37	+·22	+·07	-·07	-·22	-·37	-·52	-·67	$\times W$
$V = V_1 - F$	-·27	-·12	+·03	+·18	+·33	+·47	-·38	-·23	-·08	+·07	$\times W$

The following table gives values of V for W at each point of division.

Table V.

$V = SW$, values of S .

Spaces	1	2	3	4	5	6	7	8	9	10
W on 1	+·679	-·272	-·223	-·174	-·125	-·075	-·026	+·023	+·072	+·121
2	+·382	+·475	-·432	-·339	-·246	-·154	-·061	+·032	+·125	+·218
3	+·128	+·255	+·382	-·491	-·364	-·236	-·109	+·018	+·145	+·272
4	-·07	+·08	+·23	+·38	-·47	-·33	-·18	-·03	+·12	+·27
5	-·204	-·048	+·108	+·264	+·420	-·420	-·264	-·108	+·048	+·204
6	-·27	-·12	+·03	+·18	+·33	+·47	-·38	-·23	-·08	+·07
7	-·272	-·145	-·018	+·109	+·236	+·364	+·491	-·382	-·255	-·128
8	-·218	-·125	-·032	+·061	+·154	+·246	+·339	+·432	-·475	-·382
9	-·121	-·072	-·023	+·026	+·075	+·125	+·174	+·223	+·272	-·679

The panel load W being known, the shear can be found at once from the above table for any distribution of the loads desired.

CHAPTER XV.

REINFORCED CONCRETE.

107. Reinforced concrete.

Concrete possesses a relatively high compressive strength, but is weak in tensile strength. It is cheap, practically fireproof, and protects steel embedded in it from corrosion.

Steel is capable in resisting great tensile and shearing stress, but when exposed to the air it soon rusts; and when exposed to high temperatures is liable to expand and distort.

For all structural members, such as beams, subject to both tension and compression, the two materials can be combined with advantage. Steel rods are embedded in the concrete near the tension edge of the beam, and the tensile stresses are carried by them. The concrete takes the compression, and forms a protection for the steel from the effects of heat and atmosphere. Reinforced concrete is now used largely in modern designs for beams, girders, columns, bridges, retaining walls, floors, tanks, pile work, &c.

The concrete is usually composed of cement, sand, and broken stone in the proportions 1 : 2 : 4 or 1 : 2½ : 5. The cement should be up to the British standard specification, the sand should be clean and sharp, and the size of the stones from ¾ inch to 1½ inch according to the description of work. The concrete should be thoroughly mixed, first dry, then wet, and deposited rather wet so as not to require much ramming.

108. Compressive strength of concrete. Working stresses for concrete and steel.

The R.I.B.A. Reinforced Concrete Committee recommend the following:—

If concrete is of such a quality that its crushing strength is from 2400 to 3000 lbs. per square inch after 28 days, and if the

steel has a breaking tensile strength of not less than 60,000 lbs. per square inch.

Concrete in compression in beams subject to bending	600 lbs. per sq. in.
Concrete in columns under simple compression	500 " " "
Concrete in shear in beams	60 " " "
Adhesion of concrete to steel	100 " " "
Steel in tension	15,000 " " "

Adhesion.—The force of adhesion between concrete and plain steel may be taken as $\frac{1}{3}$ of a ton per square inch, or 250 lbs. per square inch. Assuming a factor of safety of 4, we get a working stress of 60 lbs. per square inch.

As regards the cross sectional area, it is better to use bars of small area, as their perimeter is proportionately greater than a lesser number of large bars giving the same total area of section. They can also be bent into position more easily.

Bars are not usually used of more than $1\frac{1}{4}$ " to $1\frac{1}{2}$ " diameter. For increasing the adhesive force several special forms of bars are in use, such as the twisted bar and the indented bar. With these the working stress for adhesion may be taken at from 100 to 120 lbs. per square inch.

Shearing Reinforcement of web.

Various methods have been adopted for reinforcing the web with steel. In one method the horizontal bars are bent up near the supports, or separate inclined rods are used attached to the horizontal ones. The 'Kahn' bar is a special form in which the horizontal bar is cut into strips at the ends, and these are bent upwards.

Another form of reinforcement consists of vertical 'stirrups' or thin bars of steel looped round the horizontal bars having their ends bent out at the top so as to grip the concrete. These stirrups are also used in combination with inclined bars. The distance apart of the stirrups varies from about $\frac{1}{2}$ to $\frac{3}{4}$ the depth of beam.

Other forms of reinforcement are by means of expanded metal, or by rods formed into truss shape.

Without reinforcement in the concrete the working stress for shear is about 25 to 30 lbs. per square inch. With reinforcement the working stress may be taken at 60 lbs. per square inch. The working shear stress for steel 12,000 lbs. per square inch.

Distance apart of the steel bars.

There should be a clear distance of *at least* $1\frac{1}{2}$ diameters between the bars; and the same between the outside bars and the surface of the concrete.

Modulus of elasticity.

The average value of the modulus of elasticity of good concrete is about 2,000,000 lbs. per square inch; that of mild steel 30,000,000 lbs. per square inch. Hence the ratio of the modulus of elasticity of the steel to that of the concrete may be taken as 15 to 1.

This ratio may be assumed to be the same for both compression and tension.

109. Reinforced concrete beams.*Notation.*

Let E_s be the modulus of elasticity of the steel.

„ E_c „ „ „ „ „ concrete.

„ r „ „ ratio of E_s to E_c .

„ A_s „ „ cross sectional area of the steel.

„ b „ „ breadth of beam.

„ d „ „ depth from compressive edge of beam to steel.

„ p „ „ ratio of area of steel to area of beam above the

steel, i.e., $\frac{A_s}{bd}$.

„ y_1 „ „ depth from compressive edge to neutral axis.

„ f_s „ „ the stress per square inch for steel.

„ f_c „ „ „ „ „ concrete.

Assumptions.

As in the ordinary theory of bending, it is assumed (a) that the section of beam which is plane before bending remains plane after bending; (b) the resultant compressive stress is equal to the resultant tensile stress.

From (a) it follows that the strains or deformations of the fibres at a section of beam are proportional to their distances from the neutral axis.

110. Ordinary theory neglecting the tensional resistance of the concrete. Straight line distribution of stress.

It is assumed that the whole of the tensile stress is taken by the steel reinforcement, and that for the concrete 'stress is proportional to strain,' which means that the intensity of stress on any fibre of a cross section of a beam is proportional to the distance of the fibre from the neutral axis. The intensities of stress in the concrete up to the working stresses vary as the ordinates to a straight line.

The law of variation of the modulus of elasticity is uncertain, and in assuming a straight line distribution of stress up to the

working stresses, *i.e.*, E_c constant, the error involved must be very small and is on the side of safety.

Position of neutral axis.

Since the deformations or strains vary as the distances from the neutral axis, we see from Fig. 145 that:

$$\frac{\text{Strain in steel}}{\text{Strain in outside fibre of concrete}} = \frac{d - y_1}{y_1}$$

$$\begin{aligned} \therefore \frac{d - y_1}{y_1} &= \frac{\frac{f_s}{E_s}}{\frac{f_c}{E_c}} = \frac{E_c}{E_s} \frac{f_s}{f_c} \\ &= \frac{f_s}{r f_c}, \text{ where } r = \frac{E_s}{E_c} \dots \dots \dots (1). \end{aligned}$$

$$\therefore \frac{y_1}{d} = \frac{1}{1 + \frac{f_s}{r f_c}} \dots \dots \dots (2).$$

This gives the position of neutral axis when f_s and f_c are known.

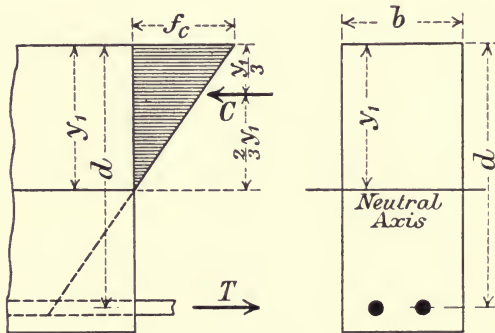

Fig. 145.

To find position of neutral axis when the size of the steel bars—that is, A_s is given.

f_s may be assumed uniform, since the sectional area of bars is small.

Now, since the resultant compression is equal to the resultant tension (Fig. 145),

we have $\frac{1}{2} f_c y_1 b = f_s A_s = f_s p b d \dots \dots \dots (3).$

Since $p = \frac{A_s}{b d}$

Therefore from Equation (3)

$$p = \frac{f_c}{f_s} \cdot \frac{y_1}{2d}$$

Eliminating $\frac{f_c}{f_s}$ by Equation (1),

$$p = \frac{y_1}{2d} \left\{ \frac{y_1}{r(d-y_1)} \right\} = \frac{y_1^2}{2dr(d-y_1)}$$

$$\therefore y_1^2 + 2dpr y_1 - 2d^2 pr = 0.$$

$$\therefore y_1 = -dpr \div \sqrt{2d^2 pr + (dpr)^2},$$

or

$$\frac{y_1}{d} = pr \left(\sqrt{1 + \frac{2}{pr}} - 1 \right) \dots \dots \dots (4).$$

From this equation the position of neutral axis can be found.

From (4) it is seen that $\frac{y_1}{d}$ increases as p or r increases.

Table of values of $\frac{y_1}{d}$, for $r = \frac{E_s}{E_c} = 15$.

$p = \frac{A_s}{bd}$	$\frac{y_1}{d}$
·005	·32
·008	·384
·010	·418
·015	·483
·020	·53

Moment of resistance.

The resultant compression acts at the centre of area of the triangle of stress, that is $\frac{y_1}{3}$ from the compressive edge of the

beam. The arm of the couple T and C is therefore $d - \frac{y_1}{3}$.

$$\therefore M_R = C \left(d - \frac{y_1}{3} \right) = \frac{1}{2} f_c b y_1 \left(d - \frac{y_1}{3} \right) \dots \dots \dots (5),$$

or

$$M_R = T \left(d - \frac{y_1}{3} \right) = f_s A_s \left(d - \frac{y_1}{3} \right) \dots \dots \dots (6)$$

$$= f_s p b d \left(d - \frac{y_1}{3} \right).$$

The lesser of the two values of M_R should be taken. For equilibrium the moment of resistance must be equal to the maximum

bending moment of the external forces. For a given bending moment, f_c and f_s can be determined from Equations (5) and (6).

Thus,

$$f_c = \frac{2M}{by \left(d - \frac{y_1}{3} \right)}$$

$$f_s = \frac{M}{pbd \left(d - \frac{y_1}{3} \right)}$$

Having found f_c and f_s , we have from Equation (1)

$$\frac{y_1}{d} = \frac{1}{1 + \frac{r f_s}{f_c}}$$

and from (3)

$$\frac{y_1}{d} = \frac{2p f_s}{f_c}$$

$$\therefore p = \frac{1}{2 \frac{f_s}{f_c} \left(1 + \frac{f_s}{r f_c} \right)} \dots \dots \dots (7).$$

To determine the moment of resistance of a beam, when the dimensions and area of reinforcement are given, the position of neutral axis is first found from (4); then the ratio of $\frac{f_s}{f_c}$ from (2).

If this ratio is less than the ratio of the working stress on the steel to the working stress on the concrete, the reinforcement is in excess and the moment of resistance must be determined from f_c the working stress on the concrete. If $\frac{f_s}{f_c}$ is equal to or greater than this ratio, the Equation (6) containing f_s must be used.

Shear. If F is the vertical shearing force the vertical intensity of shear stress = $\frac{F}{b \left(d - \frac{y_1}{3} \right)}$.

EXAMPLES.

1. A reinforced concrete beam is 8 inches broad, and 12 inches deep to the centre of the reinforcement. If the working stress for the concrete is 600 lbs. per square inch, determine $p = \frac{A_s}{bd}$, so that the intensity of stress in the steel may be about 10,000 lbs. per square inch, also the position of the neutral axis. Assume $r = \frac{E_s}{E_c} = 15$.

If the span of the beam is 16 feet, determine what uniformly distributed load it will safely carry.

From Equation (7)

$$p = \frac{1}{\frac{2 \times 10000}{600} \left(1 + \frac{10000}{15 \times 600}\right)}$$

$$= \frac{27}{1900} = 0.014.$$

Let the tension reinforcement consist of three $\frac{3}{4}$ -inch steel rods. Then,

$$A_s = 3 \times 0.442 = 1.326.$$

$$bd = 8 \times 12 = 96.$$

$$\therefore p = \frac{1.326}{96} = 0.0138.$$

Position of neutral axis.

From Equation (4)

$$y_1 = 12 \times 0.0138 \times 15 \left(\sqrt{1 + \frac{2}{0.0138 \times 15}} - 1 \right)$$

$$= 5.64 \text{ inches.}$$

Moment of resistance or safe bending moment considering the concrete is from Equation (5).

$$M_R = \frac{600}{2} \times 8 \times 5.64 (12 - 1.88)$$

$$= 136984 \text{ inch lbs.}$$

$$= 11415.4 \text{ foot lbs.}$$

The stress in the steel from Equation (6) is

$$f_s = \frac{M_R}{A_s \left(d - \frac{y_1}{3} \right)} = \frac{136984}{1.326 \times 10.12}$$

$$= 10.2 \text{ lbs. per sq. in.}$$

The span being 16 feet, let W = total uniformly distributed load. Then $\text{Max. } BM = \frac{Wl}{8} = \frac{W \times 16}{8}$.

$$\therefore \frac{W \times 16}{8} = 11415.4 \text{ foot lbs.}$$

$$\therefore W = 5707.7 \text{ lbs.}$$

2. *Design a reinforced concrete beam 14 feet span, to carry a uniformly distributed load of 500 lbs. per foot run; if the working strengths of the concrete and steel are 600 and 10,800 lbs. per square inch respectively.*

Assume

$$r = \frac{E_s}{E_c} = 15.$$

By Equation (7)

$$p = \frac{1}{\frac{2 \times 10800}{600} \left(1 + \frac{10800}{15 \times 600}\right)}$$

$$= 0.0126.$$

From Equation (4)

$$\frac{y_1}{d} = 0.0126 \times 15 \left(\sqrt{1 + \frac{2}{0.0126 \times 15}} - 1 \right)$$

$$= 0.456$$

From Equation (6)

$$M_R = f_s p b d \left(d - \frac{y_1}{3} \right).$$

$$\therefore M_R = 10800 \times 0.0126 b d \left(d - \frac{0.456 d}{3} \right)$$

$$= 136.1 \times 0.848 b d^2$$

$$= 115.4 b d^2 \text{ inch lbs. ; } b \text{ and } d \text{ being in inches.}$$

The maximum bending moment = $\frac{Wl}{8}$

$$= \frac{500 \times 14 \times 14 \times 12}{8} \text{ inch lbs.}$$

$$= 147000 \text{ inch lbs.}$$

Equating Max. BM to M_R

$$115.4 b d^2 = 147000.$$

$$b d^2 = \frac{147000}{115.4} = 1273.8.$$

Take $b = 8$ inches.

$$\text{Then } d^2 = \frac{1273.8}{8} = 159.2.$$

$$\therefore d = 12.6, \text{ say } 13 \text{ inches.}$$

$$A_s = 0.0126 (8 \times 13) = 1.31 \text{ sq. in.}$$

$$\text{The area of a } \frac{3}{4}\text{-inch bar} = 0.442 \text{ sq. in.}$$

Hence, use three steel bars $\frac{3}{4}$ -inch diameter—that is, 1.326 square inches (Fig. 146).

$$y_1 = 0.456 \times 13 = 6 \text{ inches.}$$

3. A floor slab of reinforced concrete is 6 inches thick and 7 feet 6 inches span. The slab is reinforced with steel bars $\frac{1}{2}$ -inch diameter, spaced 4 inches apart centre to centre, and $1\frac{1}{2}$ inches from the lower

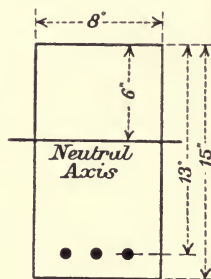

Fig. 146.

edge. If the load on the floor is 320 lbs. per square foot (including the weight of the floor), determine the stresses in the steel reinforcement and in the concrete. Find also the maximum intensity of shear stress.

The length of span, $l = 90$ inches.

Depth of floor, $d = 6 - 1\frac{1}{2} = 4\frac{1}{2}$ inches.

Take a breadth of slab, $b = 12$ inches.

Reinforcement.

Since in every 12 inches breadth of slab there are 3 bars each 0.196 square inch in sectional area,

$$p = \frac{A_s}{bd} = \frac{3 \times 0.196}{12 \times 4.5} = 0.0109.$$

Position of neutral axis.

From Equation 4, Art. 110,

$$\frac{y_1}{d} = pr \left(\sqrt{1 + \frac{2}{pr}} - 1 \right)$$

$$\therefore y_1 = 4.5 \times 0.0109 \times 15 \left(\sqrt{1 + \frac{2}{0.0109 \times 15}} - 1 \right) \\ = 1.95 \text{ inch,}$$

and $d - \frac{y_1}{3} = 4.5 - 0.65 = 3.85$ inches;

$$\text{also max. } M = \frac{wl^2}{8} = \frac{320}{12} \times \frac{8100}{8}$$

$$= 27000 \text{ inch lbs. on each foot of breadth.}$$

Hence, from Equation 5, Art. 110,

$$f_c = \frac{2M}{by_1 \left(d - \frac{y_1}{3} \right)} = \frac{2 \times 27000}{12 \times 1.95 \times 3.85}$$

$$= 600 \text{ lbs. per square inch.}$$

From Equation 6, Art. 110,

$$f_s = \frac{M}{A_s \left(d - \frac{y_1}{3} \right)} = \frac{27000}{3 \times 0.196 \times 3.85}$$

$$= 11927 \text{ lbs. per square inch.}$$

$$\text{Max. shearing force} = F = \frac{320 \times 7\frac{1}{2}}{2}$$

$$= 1200 \text{ lbs}$$

Max. intensity of shear stress

$$= \frac{F}{b\left(d - \frac{y_1}{3}\right)} = \frac{1200}{12 \times 3.85}$$

$$= 26 \text{ lbs. per square inch.}$$

111. Theory assuming a parabolic distribution of stress for compression, and neglecting the tensional resistance in concrete.

The stress strain curve for concrete is practically a straight line up to the safe working stress allowable; consequently the design of beams is in practice usually worked out as in Art. 110, assuming a straight line distribution of stress; but as the stress strain curve is sometimes assumed to be parabolic, the following theory is given in which failure is assumed to take place by the crushing of the concrete, the stress in the steel being within the elastic limit. The stress curve is a parabola with its vertex on the compression edge.

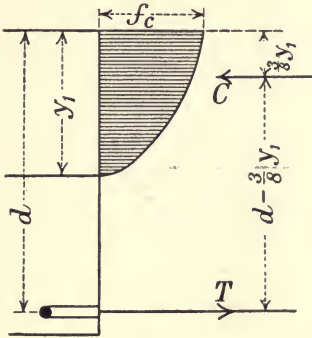

Fig. 147.

Position of neutral axis.

Let y_1 be the depth of neutral axis below the compression edge. Then the stress diagram being a parabola, its area is $\frac{2}{3} f_c y_1$ and the depth of its centre of area below compression edge is $\frac{2}{3} y_1$. Now, on the assumption that plane sections remain plane after bending,

$$\frac{d - y_1}{y_1} = \frac{\frac{f_s}{E_s}}{\frac{f_c}{E_c}} = \frac{f_s E_c}{f_c E_s} = \frac{f_s}{r f_c}$$

$$\therefore y_1 = d \left(\frac{1}{1 + \frac{f_s}{r f_c}} \right) \dots \dots \dots (1).$$

And

$$\frac{f_s}{f_c} = r \frac{(d - y_1)}{y_1} \dots \dots \dots (2).$$

Since total compression is equal to the total tension

$$A_s f_s = p b d f_s = \frac{2}{3} f_c y_1 b.$$

$$\therefore p f_s = \frac{2}{3} \frac{f_c y_1}{d}.$$

Substituting from (1)

$$p = \frac{2}{3} \frac{1}{\frac{f_s}{f_c} \left(1 + \frac{f_s}{rf_c}\right)} \dots\dots\dots (3).$$

Substituting for $\frac{f_s}{f_c}$ from (2)

$$\begin{aligned} p &= \frac{2}{3} \frac{1}{\frac{r(d-y_1)}{y_1} \left(1 + \frac{d-y_1}{y_1}\right)} \\ &= \frac{2}{3} \frac{y_1^2}{r(d-y_1)d} \\ \therefore y_1^2 &= \frac{3}{2} prd^2 - \frac{3}{2} prdy_1 \\ \therefore \left(\frac{y_1}{d}\right)^2 + \frac{3}{2} pr \frac{y_1}{d} - \frac{3}{2} pr &= 0. \end{aligned}$$

$$\therefore \frac{y_1}{d} = -\frac{3}{4} pr + \sqrt{\left(\frac{3}{4} pr\right)^2 + \frac{3}{2} pr},$$

or
$$\frac{y_1}{d} = \frac{3}{4} pr \left\{ \sqrt{1 + \frac{8}{3rp}} - 1 \right\} \dots\dots\dots (4),$$

which gives y_1 , the position of the neutral axis.

Ultimate resisting moment for the concrete.

$$\begin{aligned} M_R &= C(d - \frac{3}{8}y_1) \\ &= \frac{2}{3} f_c y_1 b (d - \frac{3}{8}y_1) \dots\dots\dots (5). \end{aligned}$$

Having found M_R for the concrete, it should be seen if the stress in the steel reinforcement is within the elastic limit ;

thus
$$f_s = \frac{M_R}{A_s(d - \frac{3}{8}y_1)} \dots\dots\dots (6).$$

112. Professor Talbot has worked out the following formula based on the parabolic distribution when the maximum compressive stress in the concrete has not reached its ultimate value :—

λ_c = deformation per unit of length at outside compressive edge of concrete.

λ_c^1 = ultimate deformation per unit of length at crushing.

f_c = intensity of stress at outside compressive edge of concrete.

f'_c = ultimate intensity of stress at crushing.

$$q = \frac{\lambda_c}{\lambda_c^1}.$$

x = distance from the compressive edge to the centre of area of compressive stress.

When f_c the stress at the compressive surface is less than f'_c the ultimate stress, the locus of the vertex of the parabola is above the compressive surface,

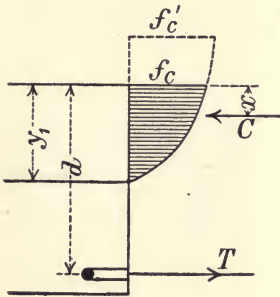

Fig. 148.

and $\frac{f_c}{f'_c} = (1 - \frac{1}{2}q)2q \dots\dots\dots (1).$

Position of neutral axis.

$$\frac{y_1}{d} = \sqrt{\frac{2pr}{1 - \frac{q}{3}} + \frac{p^2r^2}{(1 - \frac{q}{3})^2}} - \frac{pr}{1 - \frac{q}{3}} \quad (2).$$

Centre of area of parabola of stress.

$$\frac{x}{y_1} = \frac{4-q}{12-4q} \dots\dots\dots (3).$$

Average ordinate of parabola.

$$\frac{1 - \frac{q}{3}}{2 - q} = f_c \frac{3 - q}{3(2 - q)},$$

Hence moment of resistance for the concrete is

$$M_R = C(d - x) = \frac{3 - q}{3(2 - q)} f_c y_1 b (d - x).$$

Moment of resistance for steel:

$$M_R = T(d - x) = f_s A_s (d - x) = f_s p b d (d - x).$$

And if the bending moment M is given, f_c and f_s can be found by writing M for M_R .

For ordinary working conditions q may be taken = $\frac{1}{4}$.

113. Reinforced concrete floors.

A floor of reinforced concrete consists of reinforced concrete slabs formed in one monolithic mass with reinforced concrete beams (Fig. 149).

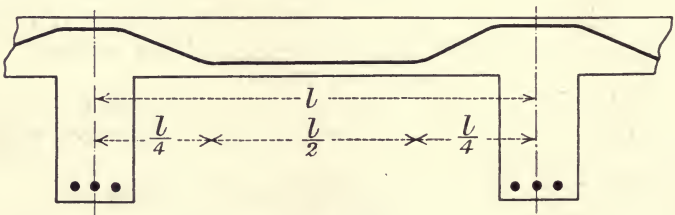

Fig. 149.

The slabs may be considered as fixed at the ends, and as for fixed beams the bending moment is positive at the centre and

negative at the ends over the supports. Hence the reinforcement, which at the centre is near the lower surface, should over the supports be placed near the upper surface. This is usually done by bending the reinforcing rods upward as in Fig. 149.

The maximum bending moment at the centre and supports is usually taken as

$$\text{Max. } M = \frac{wl^2}{12}.$$

The width of slab to be taken as forming the flange of T-beam should not exceed $\frac{3}{4}$ of the distance between the centre lines of beams.

114. T-beams. Assuming a straight line variation of compressive stress, and neglecting the tensional resistance of the concrete.

The width of the upper flange b_1 forming the floor (Fig. 150) should for calculation not exceed $\frac{3}{4}$ of the distance between centre to centre of beams.

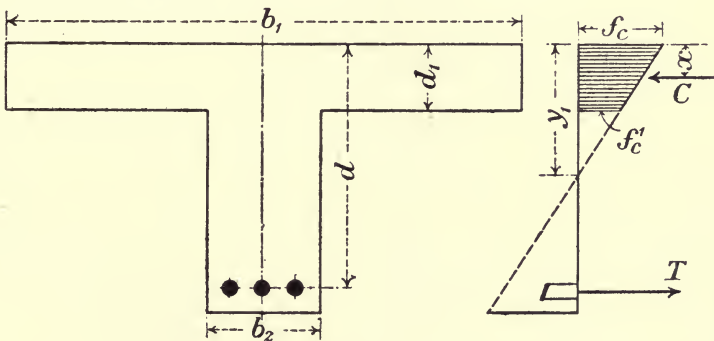

Fig. 150.

The thickness d_1 of the floor slab should first be got by considering the portion between the two beams or ribs as a slab, with its reinforcing bars transverse to the beam (Fig. 149). (See Example 3, Art. 110.)

The depth d of beam or rib is usually taken from $\frac{1}{12}$ th to $\frac{1}{15}$ th of the span.

Let b_1 = width of flange of T.

„ d_1 = thickness of flange.

„ b_2 = width of web.

„ d = depth from top of flange to centre of reinforcement.

„ y_1 = depth of neutral axis from top of flange.

„ x = depth of centre of area of compressive stress from top of flange.

There are two cases to consider, according as d_1 is greater than or less than y_1 , the distance of neutral axis from upper compressive edge of flange.

115. CASE I.—The neutral axis in the flange.

I.e. y_1 less than d_1 .

This case is the same as for rectangular beams, and the formula of Art. 110 can be used, except that b_1 , the width of flange, should be substituted for b .

$$p = \frac{A_s}{b_1 d}$$

116. CASE II.—Neutral axis in the web.

I.e. y_1 greater than d_1 .

It is sufficiently accurate to neglect the small compressive resistance of the web of T-beams.

Let f_c = intensity of compressive stress at top of flange.

„ f_c^1 = „ „ „ „ at bottom of flange.

From stress-strain diagram, Fig. 150 :

$$\frac{y_1}{d - y_1} = \frac{\frac{f_c}{E_c}}{\frac{f_s}{E_s}} = \frac{r f_c}{f_s} \dots\dots\dots(1).$$

Again,
$$\frac{f_c^1}{f_c} = \frac{y_1 - d_1}{y_1} \dots\dots\dots(2).$$

$$\therefore \frac{f_c + f_c^1}{2} = f_c \frac{(2y_1 - d_1)}{2y_1} = \frac{f_c}{y_1} \left(y_1 - \frac{d_1}{2} \right) \dots\dots\dots(3).$$

This is the mean compressive stress on flange.

Hence, since $C = T$,

$$\frac{f_c}{y_1} \left(y_1 - \frac{d_1}{2} \right) b_1 d_1 = f_s A_s \dots\dots\dots(4).$$

Eliminating $\frac{f_s}{f_c}$, we get

$$y_1 = \frac{b_1 d_1^2 + 2rd A_s}{2(b_1 d_1 + r A_s)} \dots\dots\dots(5),$$

which gives the position of the neutral axis.

The distance x of the centre of area of trapezium of stress from the top of flange is

$$x = \frac{d_1}{3} \cdot \frac{f_c + 2f_c^1}{f_c + f_c^1}.$$

Substituting from (1) we get

$$x = \frac{d_1}{3} \cdot \frac{3y_1 - 2d_1}{2y_1 - d_1} \dots \dots \dots (6).$$

Moment of resistance.

For the concrete

$$M_R = C(d-x) = \frac{f_c}{y_1} \left(y_1 - \frac{d_1}{2} \right) b_1 d_1 (d-x) \dots \dots (7).$$

For the steel

$$M_R = A_s f_s (d-x) \dots \dots \dots (8).$$

For a given bending moment M , which must be equal to the moment of resistance, we can determine f_c and f_s .

EXAMPLES.

1. T-beam, flange 40 inches wide and 4 inches thick ; depth to reinforcement 18 inches ; width of web 9 inches. Determine the reinforcement for beam or rib and the safe bending moment for working stresses $f_c = 500$ lbs. per square inch ; $f_s = 12,000$ lbs. per square inch. Assume $r = 15$.

From (1)

$$\frac{y_1}{d-y_1} = \frac{r f_c}{f_s}$$

$$\therefore \frac{d-y_1}{d} = \frac{1}{1 + \frac{r f_c}{f_s}}$$

$$\therefore d-y_1 = \frac{18}{1 + \frac{15 \times 500}{12000}} = 11.25 \text{ inches.}$$

$$y_1 = 18 - 11.25 = 6.75 \text{ inches.}$$

From (4)

$$\frac{500}{6.75} (6.75 - 2) 40 \times 4 = 12000 A_s.$$

$$\therefore A_s = 4.7 \text{ sq. in.}$$

Take 4 bars $1\frac{1}{4}$ inch diameter.

From (6)

$$x = \frac{4 \cdot 3 \times 6.75 - 8}{3 \cdot 2 \times 6.75 - 4} = 1.7 \text{ inches.}$$

From (8). Safe bending moment

$$M = 12000 \times 4.7 \times 16.3 = 919320 \text{ inch lbs.}$$

$$= 76610 \text{ foot lbs.}$$

2. A floor 4 inches thick is supported on reinforced concrete beams 6 feet apart centre to centre, the span being 25 feet. The

floor slab with the beams form T-beams. If the floor is to carry a load of 180 lbs. per square foot, determine the reinforcement. Assume $r = 15$. Working stresses: concrete, compression 600 lbs. per square inch; steel, tension 14,000 lbs. per square inch.

The effective width of the slab should not exceed $\frac{3}{4}$ of the distance apart of the beams centre to centre.

Therefore, width of slab, $b_1 = \frac{3}{4} \times 6 = 4\frac{1}{2}$ feet = 54 inches.

Weight of one square foot of slab, taking the weight of concrete at 150 lbs. per cubic foot is 50 lbs. Weight of beam, say, 10 lbs. per square foot.

Total weight per square foot

$$= 180 + 60 = 240 \text{ lbs.}$$

$$\text{Max. } M = \frac{wl^2}{12} = \frac{240 \times 6 \times 25^2}{12} \text{ foot lbs.}$$

$$= 900000 \text{ inch lbs.}$$

From (1)

$$\frac{d - y_1}{y_1} = \frac{f_s}{rf_c}$$

$$\begin{aligned} \therefore d - y_1 &= d \left\{ \frac{1}{1 + \frac{rf_c}{f_s}} \right\} \\ &= d \left\{ \frac{1}{1 + \frac{15 \times 600}{14000}} \right\}. \end{aligned}$$

Take $d = 15$ inches.

Then,

$$y_1 = 15 - 9 = 6 \text{ inches.}$$

From (6)

$$x = \frac{4}{3} \cdot \frac{18 - 8}{12 - 4} = \frac{40}{24} = 1.67 \text{ inch.}$$

From (8)

$$M = A_s f_s (d - x).$$

$$900000 = A_s \times 14000 \times 13.33.$$

$$\therefore A_s = \frac{900000}{14000 \times 13.33}$$

$$= 4.8 \text{ sq. in.}$$

Say, 6 rods 1 inch diameter.

3. A floor 28 feet span is constructed as in Fig. 149. The floor slab is 5 inches thick and the beams are 7 feet apart centre to centre. The reinforcement of each beam near the lower edge consists of six

steel bars 1 inch diameter placed in two rows of 3 bars. If the load on floor is 120 lbs. per square foot, determine the maximum stresses per square inch in the concrete and steel. Assume $d = \frac{\text{span}}{14}$; $r = 15$.

Loading.—If the weight of floor and beams is assumed to be 70 lbs. per square foot, then

Total load = 7 (70 + 120) = 1330 lbs. per lineal foot.

Referring to Fig. 150, Art. 114,

Width of slab to be taken as acting with the beams

$$= b_1 = \frac{3}{4} \cdot 7 = 5.25 \text{ feet} = 63 \text{ inches.}$$

$$d_1 = 5 \text{ inches.}$$

$$d = \frac{28 \times 12}{14} = 24 \text{ inches.}$$

$$b_2 = 12 \text{ inches.}$$

$$A_s = 6 \times 0.785 = 4.71 \text{ sq. in.}$$

NOTE.— d is the depth from top edge of floor to the centre of reinforcement—that is, midway between the two rows of steel bars. As the centre of the reinforcement may be taken to be 4 inches from the lower edge of beams, we get the depth of the vertical leg of beam to be $28 - 5 = 23$ inches.

$$\begin{aligned} \text{Maximum bending moment} &= \frac{wl^2}{8} \\ &= \frac{1330}{12} \times 784 \times 144 \\ &= \frac{\quad\quad\quad}{8} \\ &= 1564080 \text{ inch lbs.} \end{aligned}$$

Position of neutral axis.

From Equation (5), Art. 116,

$$\begin{aligned} y_1 &= \frac{b_1 d_1^2 + 2rdA_s}{2(b_1 d_1 + rA_s)} \\ &= \frac{63 \times 25 + 2 \times 15 \times 24 \times 4.71}{2(63 \times 5 + 15 \times 4.71)} \\ &= 6.44 \text{ inches.} \end{aligned}$$

From Equation (6), Art. 116,

$$\begin{aligned} x &= \frac{5}{3} \cdot \frac{19.32 - 10}{12.88 - 5} \\ &= 1.97 \text{ inches,} \end{aligned}$$

and

$$d - x = 24 - 1.97 = 22.03 \text{ inches.}$$

Stress on concrete.

From Equation (7), Art. 116,

$$\begin{aligned} f_c &= \frac{My_1}{\left(y_1 - \frac{d_1}{2}\right)b_1d_1(d-x)} \\ &= \frac{1564080 \times 6.44}{3.94 \times 63 \times 5 \times 22.03} \\ &= 368 \text{ lbs. per sq. in.} \end{aligned}$$

Stress in steel.

From Equation (8), Art. 116,

$$\begin{aligned} f_s &= \frac{M}{A_s(d-x)} \\ &= \frac{1564080}{4.71 \times 22.03} \\ &= 15093 \text{ lbs. per sq. in.} \end{aligned}$$

Maximum shearing force at ends

$$= F = \frac{1330 \times 28}{2} = 18620 \text{ lbs.}$$

Maximum intensity of shear stress

$$\begin{aligned} &= \frac{F}{b_2(d-x)} = \frac{18620}{12 \times 22.03} \\ &= 71 \text{ lbs. per square inch.} \end{aligned}$$

In many books diagrams are given which facilitate the calculations, as in 'Principles of Reinforced Concrete,' by Turneure and Maurier, which I have consulted.

117. Beams with reinforcement for compression and tension, neglecting the tensile resistance of the concrete.

This form of reinforcement is not economical, but where the dimensions of the beam are limited, double reinforcement may be necessary in order to get a beam of sufficient strength.

Let A_s^1 = area of the steel for compression reinforcement.

„ f_s^1 = intensity of compressive stress in compressive reinforcement.

„ $p_1 = \frac{A_s^1}{bd}$.

„ d_1 = depth from upper compressive edge of concrete to centre of the compressive reinforcement.

„ C_s = resultant stress in steel compressive reinforcement.

„ C = resultant compressive stress in the concrete.

„ x = depth from upper compressive edge of concrete to the resultant of C and C_s .

Position of neutral axis.

Assume the compressive stress in the concrete to vary as the ordinates to a straight line.

From the stress strain diagram

$$\frac{d - y_1}{y_1} = \frac{\frac{f_s}{E_s}}{\frac{f_c}{E_c}} = \frac{f_s}{rf} \dots \dots \dots (1),$$

where $r = \frac{E_s}{E_c}$;

also
$$\frac{y_1 - d_1}{y_1} = \frac{f_s'}{rf_c} \dots \dots \dots (2).$$

$$\therefore f_s = rf_c \left(\frac{d}{y_1} - 1 \right),$$

and
$$f_s' = rf_c \left(1 - \frac{d_1}{y_1} \right).$$

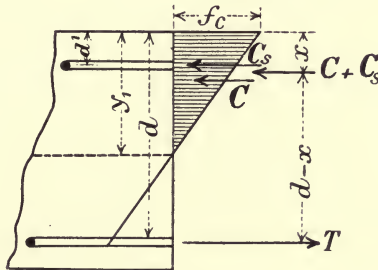

Fig. 151.

The total compression in concrete, $C = \frac{1}{2} f_c b y_1$

„ „ „ steel, $C_s = f_s' A_s' = f_s' p_1 b d$
 $= rf_c p_1 b d \left(1 - \frac{d_1}{y_1} \right).$

$$\therefore \frac{C_s}{C} = \frac{2 p_1 d r (y_1 - d_1)}{y_1^2} \dots \dots \dots (3).$$

But, since total compression is equal to the total tension,

$$C + C_s = T;$$

or,
$$\frac{1}{2} f_c b y_1 + rf_c p_1 b d \frac{(y_1 - d_1)}{y_1} = f_s A_s$$

$$= rf_c \frac{(d - y_1)}{y_1} p b d.$$

$$\therefore \frac{y_1^2}{d^2} + 2r(p + p_1) \frac{y_1}{d} - 2r \left(p + \frac{p_1 d_1}{d} \right) = 0.$$

$$\frac{y_1}{d} = r(p + p_1) \left\{ \sqrt{1 + \frac{2 \left(p + p_1 \frac{d_1}{d} \right)}{r(p + p_1)^2}} - 1 \right\}$$

which gives the position of the neutral axis.

Taking moments about T ,

$$(C + C_s)(d - x) = C_s(d - d_1) + C \left(d - \frac{y_1}{3} \right)$$

$$\frac{C + C_s}{C} x = \frac{y_1}{3} + \frac{C_s}{C} d_1.$$

The ratio of C_s to C is known from Equation (3), therefore x is known.

Moment of resistance.

$$M = f_s A_s (d - x) \text{ for tensile reinforcement,}$$

or $M = \frac{1}{2} f_c b y_1 \left(d - \frac{y_1}{3} \right) + f_s^1 p_1 b d (d - d_1)$ for compressive reinforcement.

118. Columns in which the ratio of length to least width does not exceed 15 to 18.

Let f_s = intensity of stress in the steel.

„ f_c = „ „ „ concrete.

„ A_s = area of cross section of steel.

„ A_c = „ „ „ concrete.

$$\text{„ } r = \frac{E_s}{E_c}.$$

„ λ = compression per unit of length.

Then, as long as there is perfect adhesion between the concrete and steel,

$$\lambda = \frac{f_c}{E_s}; \text{ and } \lambda = \frac{f_c}{E_c}.$$

$$\therefore \frac{f_s}{E_s} = \frac{f_c}{E_c},$$

or $f_s = \frac{E_s}{E_c} f_c = r f_c.$

Let P = total load carried by the reinforced column, then

$$P = f_s A_s + f_c A$$

$$= f_s \left(A_s + \frac{A_c}{r} \right) \dots \dots \dots (1),$$

or $= f_c (r A_s + A_c) \dots \dots \dots (2).$

EXAMPLE.—Determine the safe load for a concrete column rectangular in cross section $16'' \times 10''$, and reinforced with 4 steel bars each 1" in diameter (Fig. 152). The working compressive stress in the concrete f_c being taken as 500 lbs. per square

inch, $r = \frac{E_s}{E_c} = 15$.

$$A_s = 4 \times 0.785 = 3.14 \text{ sq. in.}$$

$$A_c = 160 - 3.14 = 156.86 \text{ sq. in.}$$

From Equation (2)

$$P = 500 (15 \times 3.14 + 156.86) \\ = 101980 \text{ lbs.} = 50 \text{ tons.}$$

From (1)

$$f_s = \frac{101980}{3.14 + \frac{156.86}{15}} = 7500 \text{ lbs. per sq. in.}$$

The vertical steel bars are usually bound at intervals of about one foot with thick wire or thin rods (Fig. 152).

EXAMPLE II.—The area of cross section of a column is 160 square inches, and the load to be carried is 80,000 lbs. If the working stress in the concrete is 400 lbs. per square inch, find the area of steel. Assume $r = 15$.

From (2)

$$80000 = 400 \{15A_s + (160 - A_s)\} \\ = 400 (14A_s + 160).$$

$$A_s = \frac{160}{56} = 2.86 \text{ sq. in.}$$

Take 4 bars 1 inch diameter.

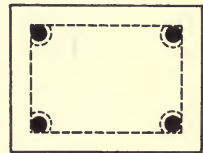

Fig. 152.

119. Bending and direct stress. Non-axial loads.

When the centre of stress does not coincide with the centre of area of cross section the distribution of stress over the surface is unequal, and it is assumed that the stress is a *uniformly varying* one. When the cross section as in reinforced concrete is composed of two materials, concrete and steel, Fig. 153 (a), which have different values of E (assume $E_s = rE_c$ as before), then the steel area may be replaced by an area of concrete equal to r times the area of the steel, placed in the plane of the steel reinforcement, Fig. 153 (b). This area may be called the equivalent area, or section of concrete equivalent in resistance to the actual section.

Thus, if A_c is the area of the concrete,

A_s „ „ „ „ steel;

then the equivalent area is

$$A_c + rA_s \dots \dots \dots (1).$$

If I is the Moment of Inertia of the equivalent area about an axis through the centre of area parallel to the side b ,

I_c the Moment of Inertia of concrete about same axis,

I_s „ „ „ „ steel „ „

then $I = I_c + rI_s \dots \dots \dots (2).$

CASE I.—COMPRESSION OVER THE WHOLE SECTION.

Let AB , Fig. 154, represent the trace of a surface on a plane at right angles to it, O being that of a line through its centre of area.

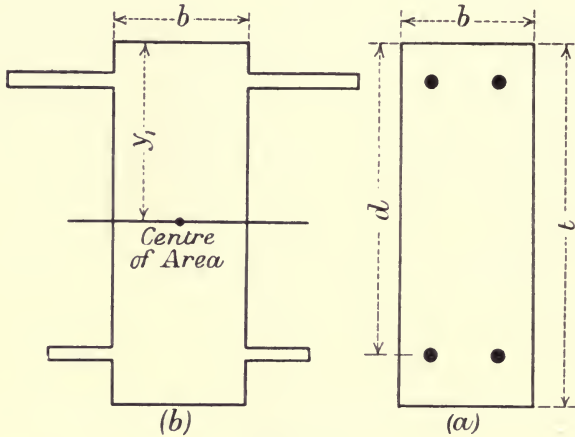

Fig. 153.

Let F be the resultant force *normal* to the surface, its line of action intersecting AB in M . F is also the resultant of the *internal stress* developed on AB .

If the line of action of the resultant force is inclined to the normal, then F is the normal component of the resultant.

Let OM , the distance from centre of stress to centre of area = y_o .

„ t = total depth or thickness of the section.

„ f_c = max. stress BC .

„ f_c^1 = min. stress AD .

„ y_1 = distance from B , the edge of section where max. stress occurs, to the centre of area O .

Let A_s = area of reinforcement nearest to the edge where max. stress occurs.

„ f_s = intensity of stress on A_s .

„ A_s^1 = area of reinforcement nearest the edge where min. stress occurs.

„ f_s^1 = intensity of stress on A_s^1 .

„ d = distance from edge of max. stress to centre of reinforcement near edge of min. stress.

„ d_1 = distance from edge of max. stress to centre of reinforcement nearest that edge.

„ I = Moment of Inertia of the equivalent area about an axis through O at right angles to the plane of the paper.

The stress represented by $ABCD$ may be taken as made up of two parts, viz. (a) a uniform stress $AGHB$ due to F at O , the intensity of which is $\frac{F}{A}$, and (b) a uniformly varying stress $GDCH$ due to a bending moment $M = Fy_0$, represented by the triangular figures CJH (compressive) and DGJ (tensile). Compressive and tensile stresses are regarded as positive and negative respectively.

The intensity of this uniformly varying stress = $\frac{My}{I} = \frac{Fy_0y}{I}$ on any fibre distant y from O .

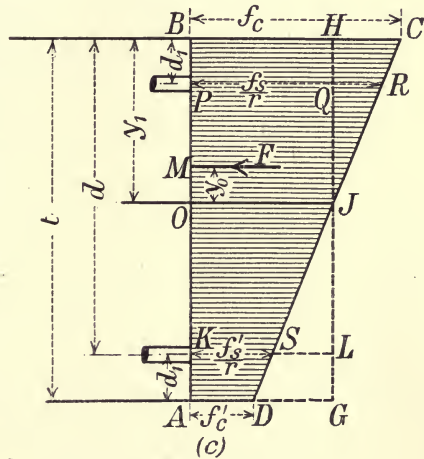

Fig. 154.

To determine y_1 , the distance of the centre of area from B .

From (1)

$$A = bt + r(A_s + A_s^1),$$

hence by moments

$$Ay_1 = bt \frac{t}{2} + rA_s d_1 + rA_s^1 d,$$

or

$$y_1 = \frac{bt^2 + 2rA_s d_1 + 2rA_s^1 d}{2bt + 2r(A_s + A_s^1)} \dots \dots \dots (3).$$

Moment of Inertia.

From (2)

$$I = I_c + I_s = \frac{b}{3} \left\{ y_1^3 + (t - y_1)^3 \right\} + A_s(y_1 - d_1)^2 + A_s^1(d - y_1)^2 \dots (4).$$

These formulæ simplify considerably if the two reinforcements are of equal area.

In this case $y_1 = \frac{t}{2}$

and $I = \frac{bt^3}{12} + 2A \left(\frac{t}{2} - d_1 \right)^2,$

Now, from Fig. 154,

$$OJ = \frac{F}{A}, PR = \frac{f_s}{r}, KS = \frac{f_s^1}{r}, \text{ and } M = F \cdot y_o,$$

$$\therefore f_c = BC = BH + HC = \frac{F}{A} + \frac{My_1}{I} \dots \dots \dots (5).$$

$$\frac{f_s}{r} = PR = PQ + QR = \frac{F}{A} + \frac{M(y_1 - d_1)}{I}$$

$$\therefore f_s = r \left\{ \frac{F}{A} + \frac{M(y_1 - d_1)}{I} \right\} \dots \dots \dots (6).$$

also $\frac{f_s^1}{r} = KL - LS = \frac{F}{A} - \frac{M(d - y_1)}{I},$

$$\therefore f_s^1 = r \left\{ \frac{F}{A} - \frac{M(d - y_1)}{I} \right\} \dots \dots \dots (7).$$

$$f_c^1 = AD = AG - GD = \frac{F}{A} - \frac{M(t - y_1)}{I} \dots \dots \dots (8).$$

Since F = resultant internal stress,

$$F = \frac{1}{2}(f_c + f_c^1)bt + f_s A_s + f_s^1 A_s^1 \dots \dots \dots (9).$$

The stresses are compressive or tensile according as the value obtained is positive or negative; thus, if f_c^1 is negative there must be some tension on the section, and if f_s^1 is negative, this reinforcement must be in tension.

EXAMPLES.

1. A reinforced concrete beam is 9 inches wide and 20 inches deep. The reinforcement both above and below consists of 2 steel rods 1 inch diameter imbedded at a depth of 2 inches. The normal component of the resultant force on a section is 60,000 lbs., acting

at a distance of 2 inches from the centre of area. Determine the maximum and minimum intensities of stress in the concrete and the intensities of stress in the steel.

Data.— $F = 60,000$ lbs.; $y_o = 2$ in.; $d_1 = 2$ in.; $t = 20$ in.;
 $\bar{d} = 18$ in.

$$A_s = A_s^1 = 1.57 \text{ sq. in.}$$

Since the reinforcement is symmetrical in area and position both above and below

$$y_1 = \frac{t}{2} = 10 \text{ in.},$$

and
$$I = \frac{9 \times 20^3}{12} + 2 \times 1.57 (10 - 2)^2$$

$$= 6200.$$

$$M = Fy_o = 60000 \times 2 = 120000 \text{ inch lbs.}$$

$$A = bt + 2rA_s$$

$$= 180 + 2 \times 15 \times 1.57$$

$$= 227 \text{ sq. in.}$$

From (5)

$$f_c = \frac{F}{A} + \frac{My_1}{I}$$

$$= \frac{60000}{227} + \frac{120000 \times 10}{6200}$$

$$= 264.3 + 193.5 = +457.8 \text{ lbs. per sq. in. compression.}$$

From (8)

$$f_c^1 = \frac{F}{A} - \frac{M(t - y_1)}{I}$$

$$= 264.3 - 193.5 = +70.8 \text{ lbs. per sq. in. compression.}$$

From (6)

$$f_s = 15 \left\{ 264.3 + \frac{120000 (10 - 2)}{6200} \right\}$$

$$= 3964.5 + 2322.6$$

$$= +6287.1 \text{ lbs. per sq. in. compression.}$$

From (7)

$$f_s^1 = 15 \left\{ 264.3 - \frac{120000 (18 - 10)}{I} \right\}$$

$$= 3964.5 - 2322.6$$

$$= +1641.9 \text{ lbs. per sq. in. compression.}$$

2. If in last example the normal compound of resultant is 50,000 lbs., distant 5 inches from the centre of area, determine the intensities of stress in the concrete and steel.

$$M = 50000 \times 5 = 250000 \text{ inch lbs.}$$

From (5)

$$\begin{aligned} f_c &= \frac{50000}{227} + \frac{250000 \times 10}{6200} \\ &= 220.3 + 403.3 \\ &= 623.6 \text{ lbs. per sq. in. compression.} \end{aligned}$$

From (8),

$$\begin{aligned} f_c^1 &= 220.3 - 403.3 \\ &= -183 \text{ lbs. per sq. in. tension.} \end{aligned}$$

f_s and f_s^1 can be obtained from Equations (6) and (7), or from the stress diagram (Fig. 155) as follows:—

By Proportion, let $BN = l$; $BA = t$.

$$\frac{l}{t-l} = \frac{f_c}{f_c^1} = \frac{623.6}{183},$$

$$\therefore \frac{l}{t} = \frac{623.6}{806.6},$$

$$\therefore l = \frac{20 \times 623.6}{806.6} = 15.46 \text{ inches.}$$

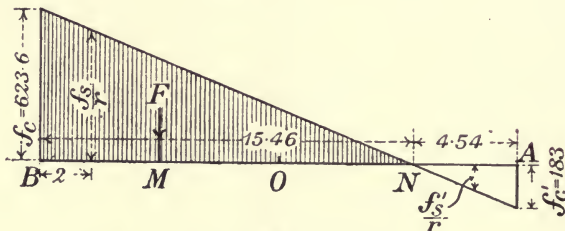

Fig. 155.

$$\frac{\left(\frac{f_s}{r}\right)}{f_c} = \frac{13.46}{15.46},$$

$$\begin{aligned} \therefore f_s &= \frac{15 \times 623.6 \times 13.46}{15.46} \\ &= 8140 \text{ lbs. per sq. in. compression.} \end{aligned}$$

$$\frac{\left(\frac{f_s^1}{r}\right)}{f_c^1} = \frac{2.54}{4.54},$$

$$\begin{aligned} \therefore f_s^1 &= -\frac{15 \times 183 \times 2.54}{4.54} \\ &= 1536 \text{ lbs. per sq. in. tension.} \end{aligned}$$

The area of concrete under compression = 9×15.46
= 139.14 sq. in.

3. An arch is 22 inches deep and is reinforced with 3 rods 1 inch diameter to each foot of width, both above and below. The rods are imbedded to a depth of 2 inches. If for one foot width of arch the normal component of resultant thrust on a section is 80,000 lbs., acting at a distance of 4 inches from the centre of area, determine the maximum intensity of compressive stress on the section. Assume $r = 15$.

$$\begin{aligned} A &= bt + 2rA_s \\ &= 12 \times 22 + 2 \times 15 \times 2 \cdot 36 \\ &= 335 \text{ sq. in.} \end{aligned}$$

$$\begin{aligned} I &= \frac{12 \times 22^3}{12} + 2 \times 2 \cdot 36 (11-2)^2 \\ &= 11030. \end{aligned}$$

$$y_1 = \frac{22}{2} = 11 \text{ inches.}$$

$$M = 80000 \times 4 = 320000 \text{ inch lbs.}$$

From (5)

$$\begin{aligned} f_c &= \frac{80,000}{335} + \frac{320000 \times 11}{11030} \\ &= 238 \cdot 8 + 319 \cdot 4 = +558 \cdot 2 \text{ lbs. per sq. in. compression.} \end{aligned}$$

120. Retaining wall.

EXAMPLE.

A reinforced concrete retaining wall with counterforts, 18 feet high, sustains an earth bank weighing 125 lbs. per cubic foot. The top of earth is horizontal, and the angle of repose is 30° . Counterforts 10 feet apart centre to centre.

Design the wall. Working stresses for concrete and steel 600 and 12,000 lbs. per square inch respectively.

Horizontal reinforcement.

The pressure at bottom of wall from Rankine's formula = 750 lbs. per square foot. The resultant pressure acting at $\frac{1}{3}$ of the height from base = 6750 lbs.

The span for the centre slab will be taken 10 feet.

Taking a strip 1 foot high and 10 feet long, design a beam to carry a load of 750 lbs. per square foot.

The slab being partially fixed at the ends

$$M = \frac{750 \times 10^2 \times 12}{12} = 75000 \text{ inch lbs.} \dots\dots(1).$$

From Equation (7), Art. 110,

$$p = \frac{1}{\frac{2 \times 12000}{600} \left(1 + \frac{12000}{15 \times 600}\right)}$$

$$= 0.0107 \dots \dots \dots (2).$$

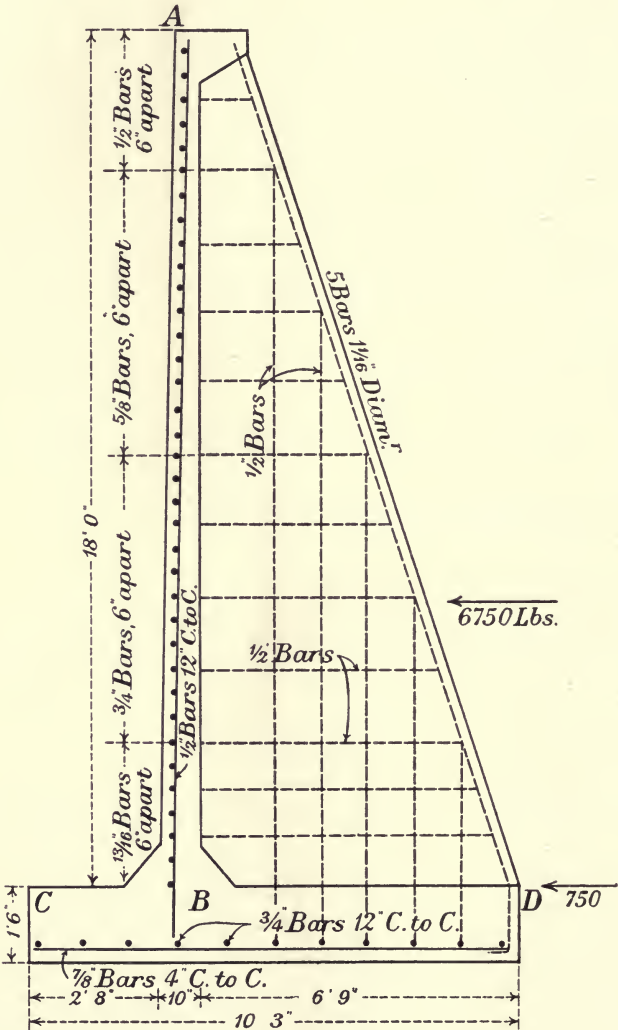

Fig. 156.

From Equation (4), Art. 110,

$$\begin{aligned} \frac{y_1}{d} &= 0.0107 \times 15 \left(\sqrt{1 + \frac{2}{15 \times 0.0107}} - 1 \right) \\ &= 0.43, \\ \therefore y_1 &= 0.43d \dots\dots\dots (3). \end{aligned}$$

Now, $M = f_s p b d \left(d - \frac{y_1}{3} \right),$

$$\begin{aligned} \therefore 75000 &= 12000 \times 0.0107 \times 12d \left(d - \frac{0.43d}{3} \right) \\ &= 12000 \times 0.0107 \times 12 \times .86d^2 \dots\dots\dots (4). \\ d &= 7\frac{1}{2} \text{ inches.} \end{aligned}$$

This is the effective depth. If the reinforcement is embedded 2 inches the total depth or thickness of wall is $9\frac{1}{2}$ inches, say 10 inches.

Area of reinforcement per foot height = pbd
 $= 0.0107 \times 7\frac{1}{2} \times 12 = 0.96$ sq. in.

Say, rods $\frac{1}{4}$ " diameter placed 6 inches apart.
 This reinforcement may be used for a height of 3 feet.

At 6 feet from bottom of wall, i.e. 12 feet from top, the pressure is 500 lbs. per square foot.

$$M = \frac{500 \times 10^2 \times 12}{12} = 50000 \text{ inch lbs.}$$

As before, $p = 0.0107,$
 $y_1 = 0.43d,$

and $M = 50000 = 12000 \times 0.0107 \times 12 \times 0.86d^2.$

Effective depth = $d = 6\frac{1}{4}$ inches.

Area of reinforcement per foot of height
 $= 0.0107 \times 6\frac{1}{4} \times 12 = 0.81$ sq. in.

Say, $\frac{3}{8}$ -inch rods 6 inches apart.

This reinforcement may be placed for the 6 feet of wall between 9 feet and 15 feet from top.

If the rods are embedded for $1\frac{3}{4}$ inch, the total depth or thickness of wall will be $6\frac{1}{4} + 1\frac{3}{4} = 8$ inches.

At 6 feet from top of wall the pressure is 250 lbs. per square foot.

As before, $p = 0.0107.$
 $y_1 = 0.43d.$
 $M = \frac{wl^2}{12} = \frac{250 \times 10^2 \times 12}{12}$
 $= 25000$ inch lbs.

and $25000 = 12000 \times 0.0107 \times 12 \times 0.86d^2$

Effective depth $d = 4\frac{3}{8}$ inches.

Total depth or thickness = $6\frac{1}{2}$ inches.

Area of reinforcement *per foot of height*

$$= 0.0107 \times 4\frac{3}{8} \times 12 = 0.56 \text{ sq. in.}$$

Say, $\frac{5}{8}$ -rods 6 inches centre to centre.

This reinforcement may be placed in the 6 feet of wall between 3 feet and 9 feet from top. Above this, for the top 3 feet use $\frac{1}{2}$ -inch rods 6 inches apart centre to centre.

Vertical reinforcement.

Vertical rods $\frac{1}{2}$ -inch diameter and 12 inches centre to centre should be placed behind the horizontal reinforcement, extending from the top of wall into the base to take up any stress due to settlement.

As the wall between counterforts is taken as a slab fixed at the ends, some additional reinforcement is necessary near back of wall to provide for the negative bending moments at these supports, as shown in Fig. 157.

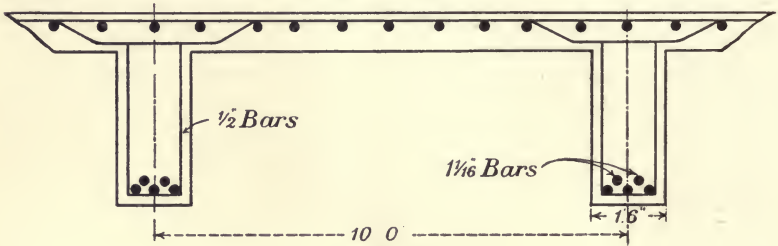

Fig. 157.

The thickness of wall at about 1 foot from the top may be 4 inches, the last foot in height being corbelled out to a thickness of 1 foot or 1 foot 6 inches at top.

Width of foundation.

Assume the bottom slab to project in front of the wall 2' 8".

Take moments about the outer middle third of bottom of base.

The overturning moment of the resultant pressure on back

$$= 6750 \times 7.5 = 50625 \text{ foot lbs.}$$

The moment of stability is the moment of the weight of filling, as the moment of weight of concrete is small and may be neglected.

Let l = projection of slab at back of wall = BD ,

then weight of filling per foot run = $125 \times 18 \times l$ lbs.

Moment of stability is

$$125 \times 18 \times l \left\{ \frac{2}{3} (l + 3.5) - \frac{l}{2} \right\}$$

Equating the moment of stability to the overturning moment we get,

$$BD = l = 6' 9'' \text{ (app.)}.$$

The total width of foundation slab is therefore 10 feet 3 inches.

Counterforts.—*Determination of the necessary reinforcements.*

The counterforts are 10 feet apart centre to centre. They may be considered as cantilevers.

The bending moment on counterfort where it joins the foundation slab is :

$$\begin{aligned} \overline{6750 \times 10} \times 6 &= 405000 \text{ foot lbs.} \\ &= 4860000 \text{ inch lbs.} \end{aligned}$$

The total thickness or depth = $6' 9'' + 10'' = 7' 7''$.

If the reinforcement is kept 3 inches from back of counterfort the effective depth $d = 7' 4'' = 88$ inches.

If p be taken 0.004,

then $y_1 = 0.3d$; and if $f_s = 14000$ lbs. per sq. in.,

From Equation (6), Art. 110,

$$\begin{aligned} M &= 4860000 = f_s A_s \left(d - \frac{y_1}{3} \right) \\ &= 14000 A_s (d - 0.1d) \\ &= 14000 A_s \times 0.9 \times 88, \\ \therefore A_s &= 4.4 \text{ sq. in.} \end{aligned}$$

Say, 5 rods $1\frac{1}{8}$ inch diameter.

These tension rods should be bent back transversely at the bottom and anchored to the reinforcement of floor slab, so as to get a good bond between the counterfort and the floor.

The counterforts will be 18 inches wide.

As shown in Fig. 156, some vertical rods $\frac{1}{2}$ -inch diameter should be placed in the counterforts to take shear and to ensure a proper bond between the floor and wall. Horizontal bars $\frac{1}{2}$ -inch diameter should also be placed in the counterforts, so as to bond them securely to the vertical wall.

Foundation slab.

The total width of base = $10' 3''$.

The weight W_1 of the earth per lineal foot above the floor

$$= 125 \times 18 \times 6\frac{3}{4} = 15187 \text{ lbs.}$$

The weight W_2 of the concrete = 6200 lbs. (app.).

The resultant thrust on back of wall is 6750 lbs.

The thrust on wall was combined graphically with the weight W_1 of the earth, and the resultant of these was combined with the weight W_2 of the concrete, and the final resultant was found to cut the base exactly at the middle third nearest the outer toe of slab.

Consequently, the maximum pressure at C

$$\begin{aligned} &= \frac{2(W_1 + W_2)}{10\frac{1}{4}} \\ &= \frac{2(15180 + 6200)}{10\frac{1}{4}} \\ &= 4172 \text{ lbs.} \end{aligned}$$

Since the pressure at D is zero, the stress diagram is a triangle and the maximum pressure at B can be found by Proportion, thus maximum pressure at B

$$= 4172 \cdot \frac{6\frac{3}{4}}{10\frac{1}{4}} = 2746 \text{ lbs.}$$

Hence from C to B the upward pressure under cantilever varies from 4172 lbs. to 2746 lbs. The upward pressure on floor BD varies from 2746 lbs. to zero. The total upward force on CB is therefore

$$\frac{4172 + 2746}{2} \times 3\frac{1}{2} = 12106.5 \text{ lbs.}$$

Moment about outer toe

$$\begin{aligned} M &= 12106.5 \times 1\frac{3}{4} = 21186.4 \text{ foot lbs.} \\ &= 254237 \text{ inch lbs.} \end{aligned}$$

Taking $p = 0.01$; by Art. 110 $\frac{y_1}{d} = 0.42$. 17

Let $f_s = 12000$ lbs. per sq in.

Since we are considering 1 foot of width, $b = 12$ inches,

$$\begin{aligned} \therefore M &= 254237 = f_s p b d \left(d - \frac{y_1}{3} \right) \\ &= 12000 \times 0.01 \times 12 \times 0.86 d^2. \end{aligned}$$

Effective depth $d = 14.3$ inches, say, 15 inches.

The total depth may be taken as 18 inches.

$$A_s = p b d = 0.01 \times 12 \times 15 = 1.80 \text{ sq. in.}$$

Use 3 bars $\frac{7}{8}$ -inch diameter—that is, $\frac{7}{8}$ -inch bars 4 inches centre to centre—for the transverse reinforcement.

The longitudinal reinforcement may be $\frac{3}{4}$ -inch rods 12 inches centre to centre.



UNIVERSITY OF CALIFORNIA LIBRARY

THIS BOOK IS DUE ON THE LAST DATE
STAMPED BELOW

MAR 3 1916

APR 19 1916

OCT 14 1919

13 Dec 30 CT

REC'D

NOV 29 1960

30m-1,15

~~Woods~~
Woods

Woods

195111

TG260

W6

4777 24

