

UC-NRLF



B 3 756 522

TRACTOR ENGINES

E. F. HALLOCK

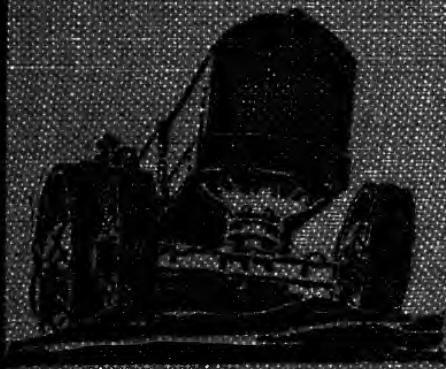

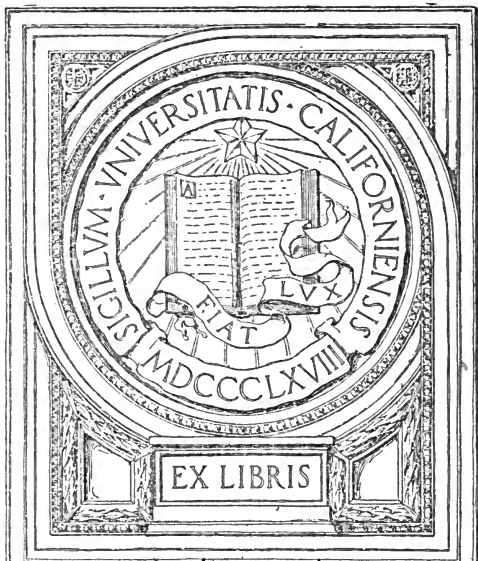

EX LIBRIS

University of California

TL 233
H28

THIS BOOK IS DUE ON THE LAST DATE
STAMPED BELOW

JUN 13 1975
JUN 26 REC'D

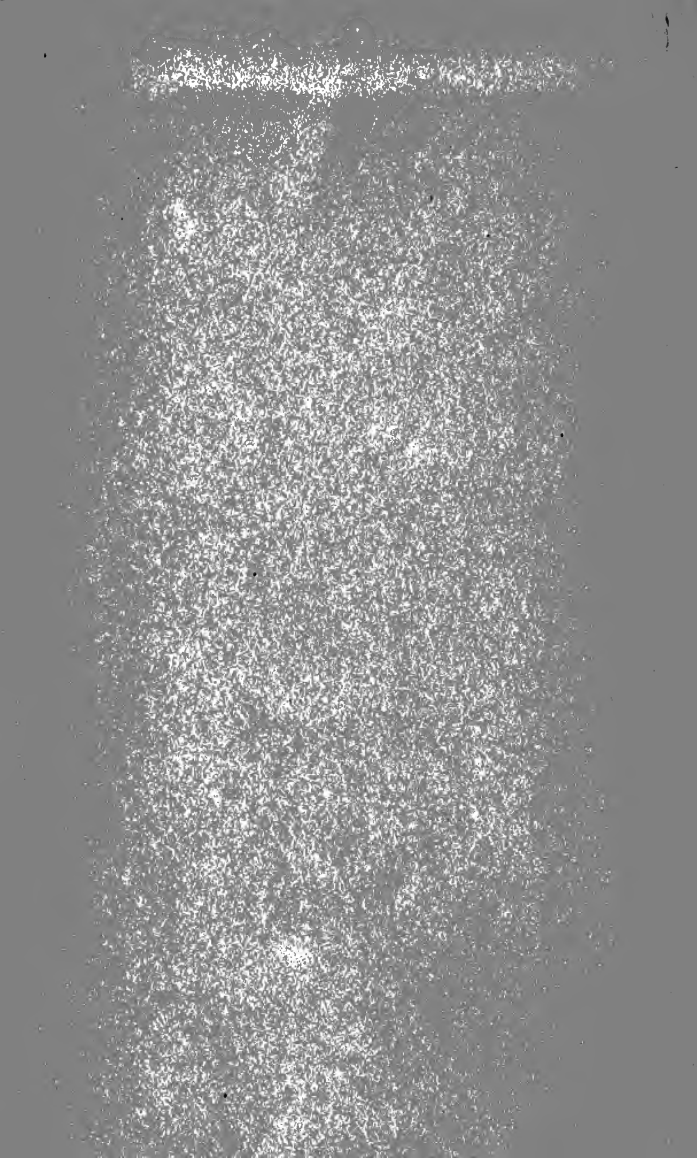





TRACTOR ENGINES

BY

EDWARD F. HALLOCK

OVER 140 ILLUSTRATIONS

A Complete Course of Lessons on the Construction
and Economical Operation of the Tractor
Engine; Adjustments and Repairs
Made Easy; How To
Acquire Maximum
Efficiency

1920

AMERICAN AUTOMOBILE DIGEST
CINCINNATI

COPYRIGHT, 1920
EDWARD ROSENTHAL
CINCINNATI, OHIO

CONTENTS.

	PAGE
CHAPTER I.	
Engine Principles.....	1
CHAPTER II.	
Features of Construction.....	13
CHAPTER III.	
Major Engine Parts.....	43
CHAPTER IV.	
Valves and Valve Mechanism.....	83
CHAPTER V.	
About the Fuel System.....	107
CHAPTER VI.	
Lubrication of the Engine.....	149
CHAPTER VII.	
Cooling	176
CHAPTER VIII.	
Care of the Cooling System.....	187
CHAPTER IX.	
Ignition System.....	193
CHAPTER X.	
Care of Ignition System.....	215
CHAPTER XI.	
Engine Troubles.....	228

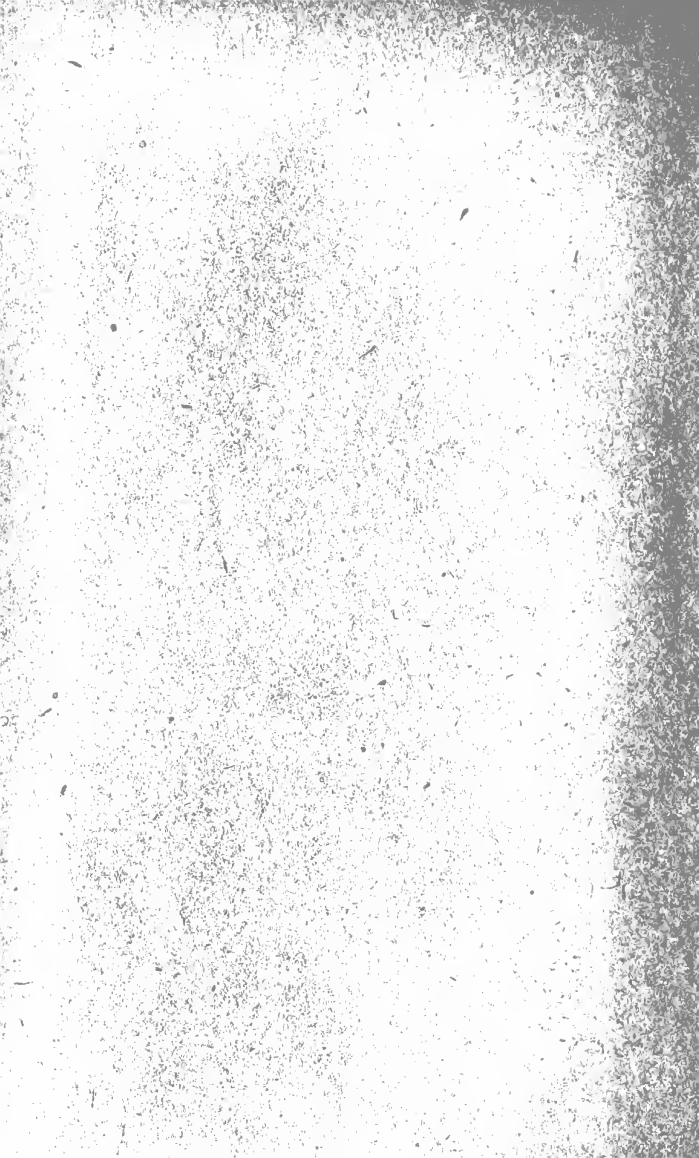

FOREWORD.

WITH the thought in mind that a clear conception of the principles involved in the operation of a piece of machinery helps considerably in the matter of keeping the apparatus in proper running condition, this little book on tractor engines has been prepared.

First consideration throughout each of the various chapters has been given to a complete exposition of the basic principles on which the matter treated with depends for its functioning; with these principles firmly implanted in the mind of the reader, we have felt better able to make plain to him the points of divergence in various constructions, and particularly the means and the methods of effecting adjustments and repairs.

It will be found, therefore, that each chapter is a separate article, quite capable of standing alone and dealing exhaustively with the subject matter in hand. This arrangement, we have felt, makes for coherence and clarity to the end that the progress of the student tractor operator or owner is furthered.

EDWARD F. HALLOCK.

NEW YORK, December 7, 1919.



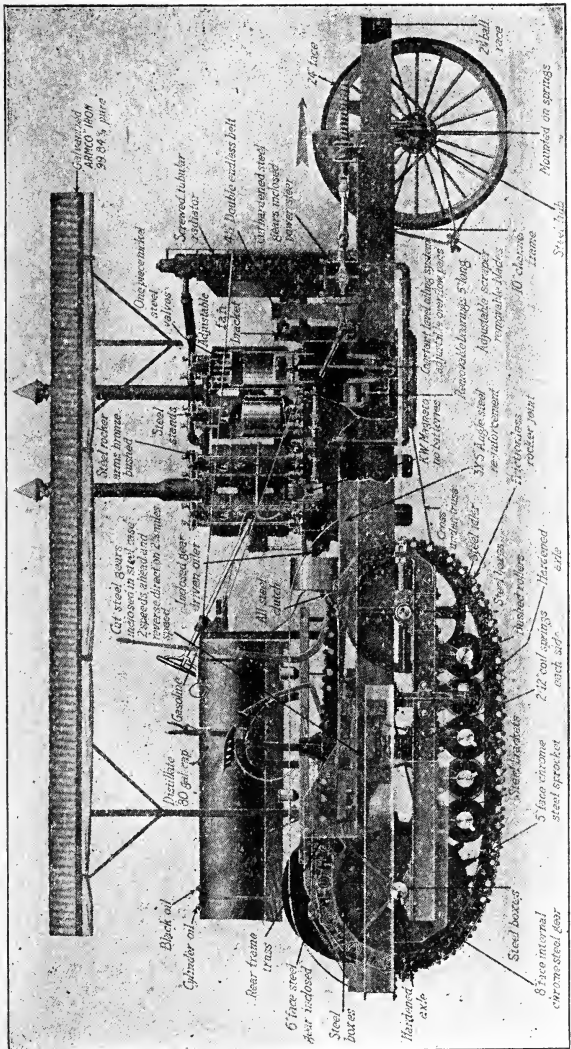

Galvanized
ARPCO IRON
93 3/4 x 3/4 pipe

One piece metal
steel valves

Screwed tubular
oscillator

4 1/2 Double endless belt
stir hardened steel
gears, enclosed
power shaft

Adjustable
bracket

24" face

Mounted on springs
Steel hub

Steel rocker
arms bronze
bushed

Steel
stands

Carton level oiling system
adjustable
new double bearings 5 long
Adjustable scraper
removable blades
10 clearance
frame

6 W Magneto
re-rotary

3/8 S Angle steel
re-tubercment

2 1/2 inch brass
Steel roller
Steel rollers
Horned
cable

Cast steel gears
inclosed in steel case
2 speeds, direct and
reverse direct on 2 1/2 miles
speed

Gasoline
30 gal. cap.

Increased gear
driver roller

All steel
clutch

Steel boxes
2-12 coil springs
each side

5 face chrome
steel sprocket

Black oil

Cylinder oil

Rear frame
truss

6 face steel
air inclosed

Steel
boxes

Horned
cable

Steel boxes

8 face internal
chrome steel gear

Typical Tractor of today sectioned to show engine parts.



CHAPTER I.

Engine Principles.

Basic Principles on Which Engine Operation Depends; Necessary Components and Cycle of Operations of the Practical Motor.

BROADLY speaking, the engine employed for the operation of any tractor is a "heat engine"—a machine for taking energy in the form of heat and converting it into useful work, which is just another way of saying mechanical energy.

The effect which heat—considering it now as a rise in temperature—has on a congregation of people is much the same as it exerts on matter in general. If, for instance, we have a crowd of folks huddled together under low temperature conditions, and we suddenly elevate the temperature greatly, the individual members of the group are going to get as far away from each other as the degree of temperature demands—in other words, until each one obtains a fair measure of comfort. In so doing, it will be appreciated that the mass will spread out over a greater area—it will expand, in other words—the expansion of the whole being due to the individual movement of the many people who make up the group.

We find that matter, be it solid, liquid or gaseous as to state, acts exactly the same under the effect of heat or change in temperature. Heat a bar of iron, for instance, and all the individual molecules will exert themselves, and the result will be the expansion of the bar exhibited as an

increase in length, width and depth—in other words, an increase in volume.

Expansion, of course, entails movement, and movement is mechanical energy. The heat we have put into the bar of metal, therefore, is not lost; but it is converted into mechanical energy and the metal bar is, in reality, a heat engine.

If now we take such a bar and hold one end fast against all movement and to the other end we attach a rod pivoted to the bar and with its other end journaled on a crank, as shown by Figure 1, it will plainly be seen that if we heat

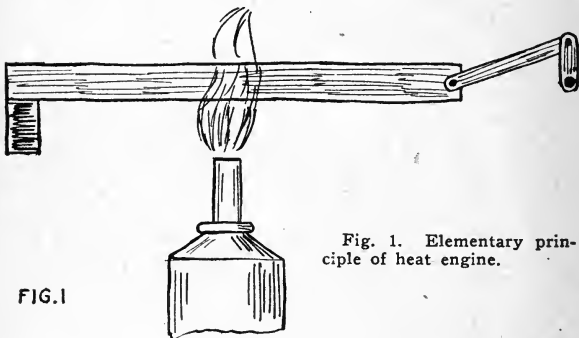

FIG.1

Fig. 1. Elementary principle of heat engine.

the bar to such an extent that it expands a distance equal to the throw or travel of the crank, the crank will be turned, imparting rotary motion to the crankshaft. It is also conceivable that mounted on that shaft we can have a fly-wheel or balance wheel which will store up sufficient energy to carry the crank over the "dead center," so that when the flame is removed and the bar begins to cool off, and thereby to contract again and return to its original size, it will carry the crank back once again, imparting rotary motion to the shaft. We therefore obtain con-

tinuous rotary motion simply by applying the flame at the proper time and withdrawing it when the outer end of the stroke is reached.

With such a simple heat engine there must be encountered considerable loss of energy. There is no means, for instance, of preventing direct heat loss by radiation; at the same time there is an indirect loss due to the fact that we are taking advantage of the longitudinal expansion of the metal only—its expansion in the other two directions takes place at the same relative rate as the elongation under the change in temperature; but the potential power from this breadth and depth expansion which entails the use of heat to engender it, is lost to us.

It is not hard to appreciate, therefore, that despite its beautiful simplicity, such an engine must be very inefficient. Other drawbacks are the element of time, for it needs a considerable interval to raise the temperature of a piece of metal, depending on the material itself and its thermal capacity, its weight, size and shape and the flame employed, and the length of bar necessary to obtain sufficient enlargement under any reasonable temperature change in order to make a practical machine.

In order to make a practical heat engine which will be sufficiently efficient to make its use desirable from an economic standpoint, the expanding medium we use must be capable of great expansion on a comparatively limited change in temperature; must be capable of undergoing this expansion with the utmost rapidity; and must be of such nature that the forces obtained from its expansion in all three directions are capable of being resolved into a single force acting in one direction without mechanical complication.

Let us consider for a moment the action of

gases under heat. We find that if we have a vessel containing one quart of any true gas at atmospheric pressure and 0 degrees Centigrade, and the vessel employed is gas tight and perfectly flexible, and we heat the gas to 1 degree C., it has expanded $1/273$ of its original volume—in other words we now have in the vessel $1.1/273$ quarts of gas. And for each increase of 1 degree C. the gas will expand $1/273$ of its volume at 0 degrees C. If, then, we heat the gas up to 273 degrees C. we will have added $273/273$ of a quart to the vessel—that is, we will have added another quart of gas to the original quart, or will have doubled its volume.

We have considered in the above that there has been no change in pressure—it has remained at atmospheric pressure throughout.

The example given is simply a concrete way of expressing a well-known law of physics, known as the Law of Charles. Given any true gas, its volume will increase by $1/273$ of its volume at 0 degrees Centigrade for every increase of 1 degree C., considering constant pressure throughout the change.

If in the case of the vessel given above, instead of being flexible it was perfectly tight and inflexible so that it could not increase in capacity, and we heated the air from 0 degrees C., and at atmospheric pressure to 273 degrees C we would have, at the latter temperature, two quarts of air forced into a one-quart vessel. Naturally, its pressure would be increased, and whereas the pressure was approximately 15 pounds to the square inch at the lower temperature and smaller volume, it would be approximately 30 pounds to the square inch at the increased temperature.

In other words, had we taken the original quart of gas and without change of temperature com-

pressed it into a half-quart vessel, we would have similarly doubled the pressure. In the instance given above, however, by increasing the temperature instead of holding it constant, we doubled the quantity of gas contained in a vessel without enlarging the vessel; and consequently we doubled its pressure.

This concretely expresses a second law of physics bearing on the behavior of gases, the Law of Boyle: The pressure of a gas varies inversely as its volume, considering constant temperature.

We find that a gas will fulfill the conditions

ASSEMBLY OF PISTON, CONNECTING ROD, AND CRANK

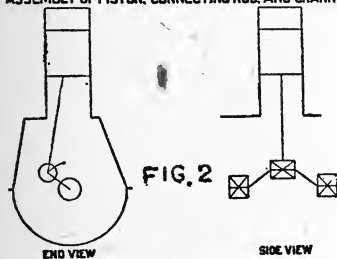

Fig. 2. The heat engine resolved into its simplest elements.

set forth above for an expansive medium for employment in a practical heat machine. Contrasted with solids and liquids, its rate of expansion per degree of temperature rise is great; at the same time, unlike the solid, it can be so confined

in a vessel that width and breadth expansion are impossible, the expansion in these directions being resolved into increased length under the heat, which is distinctly to our advantage.

Our simplest engine using a gas as the expanding medium, then, would take the form shown in Figure 2. Here we have a cylindrical vessel provided with a loose-fitting plug made just snug enough in the smooth bore of the cylinder to prevent leakage of the gas past the sides; yet sufficiently loose to permit of free up and down movement of the plug itself, which in the engine

we are pleased to call the "piston." Connecting the piston to the crank on the shaft, whereby the latter is set in motion, is a rod called the "connecting rod." The arrangement is such that every time the piston moves outward in its cylinder bore, the crank is turned, and every time it moves back, the crank is carried back, giving rotary motion to the shaft. In order to carry the crank past the dead center at each end of the piston stroke, a balance or flywheel is mounted on the shaft, which stores up sufficient energy to carry on the motion when the crank has reached its dead center.

Reference to the sketch will indicate that a quantity of air is trapped in the space above the piston in the cylinder. If, now, we apply a torch or some other source of heat to the outside of the cylinder, the trapped air within will be warmed. Air, of course, is a gas—or rather a mixture of gases—and it will accordingly follow the laws for expansion of gases under heat set forth above, with the result that pressure is created within the cylinder in exact accordance with the increase in temperature of the air within. The increase goes on until such time as the pressure on the piston becomes sufficiently great to cause it to move outward, turning the crank and setting the engine in motion.

Such, in fact, is the principle on which the hot-air engine operates. It is a slow-moving, low-powered, inefficient engine; to obviate its faults, speed of action, whereby considerably greater power is obtained with the use of the same amount of machinery, is essential.

In the internal combustion engine, therefore, instead of applying our heat to the outside of the cylinder as a means of elevating the temperature of the gases within, we intimately mix

the fuel we are using with the air which is serving as the expanding medium, in exactly the proper proportions to form a combustible mixture. When we ignite this mixture the burning of the fuel occurs almost instantaneously; there is a sudden rise and a great rise in temperature so that the air expands, causing pressure on the piston almost immediately.

In order to make a practical internal combustion engine, therefore, we must provide a cylinder, piston and crankshaft assembly exactly as indicated above; but we must also provide a means of getting a fuel charge into the cylinder at the proper time and mixed with the proper quantity of air to form an explosive mixture. Also we must provide a means of getting rid of the burned gases after they have fully expanded and performed their work on top of the piston.

We have, leading into the cylinder—or rather into the combustion chamber, which is the space in the cylinder above the piston when the latter is at top stroke, in which chamber the actual burning of the gases takes place—an intake pipe by means of which the mixture of gas (vaporized gasoline or kerosene in the case of the tractor engine) and air is introduced into the chamber at exactly the proper time. This passage is closed by means of a little valve shaped like a manhole, and provided with a stem by means of which the valve can be raised from its seat and the passage opened for the reception of the gases at the proper instant. This valve closes tight against leakage of the pressure at all other times and is normally held firmly to its seat by a strong spring. It is called the “inlet” valve or “intake” valve.

Also provided is a second passage closed by a similar valve, which is opened at the proper time for the expulsion of the burned gases, and kept tightly closed against all leakage at all other times. It is called the "exhaust" valve.

In diagrams in Figure 3, the placing of these valves and passages and the action of these valves in effecting the inlet and exhaust of the gases at exactly the proper time with relation to the piston stroke are indicated. In diagram A,

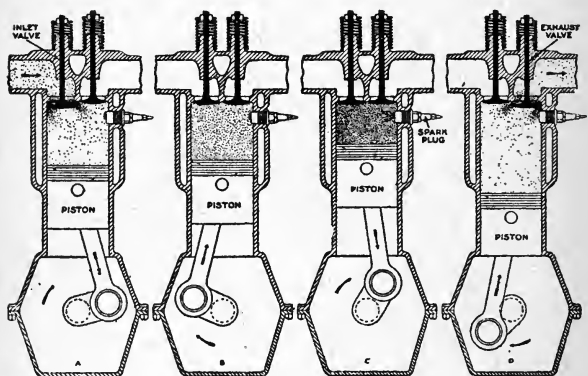

FIG. 3

Fig. 3. Indicating the four strokes in the cycle of operations of the tractor engine.

as can be plainly seen, the piston is traveling downward, and in doing so is acting like the plunger of a suction pump, creating a partial vacuum behind it. The inlet valve has been opened, and this suction created by the piston is relied upon to pull into the cylinder a full charge of mixture of proper proportions for firing from a mixing valve or a carburetor, as the case may be.

When the piston reaches bottom stroke so that no more charge can be drawn into the cylinder, the inlet valve is closed and the cylinder becomes a closed chamber. As the piston comes up, carried on by the energy stored up in the revolving flywheel, the charge is compressed. Just about the time when the piston reaches its top center and the compression is greatest, as shown in diagram *C*, an electric spark is caused to jump the gap of the spark plug, and from this spark the mixture takes fire, burns, expands, creates pressure within the cylinder which drives the piston down, imparts energy to the crankshaft and to the flywheel; whereby power is obtained.

It will be seen that on the compression stroke of the piston and on the power stroke, both intake and exhaust valves have been kept tightly closed; this, of course, is to prevent the escape of the fuel charge on the compression stroke and of the forces of combustion on the power stroke; such loss would mean reduced pressure on the piston and loss of power.

On the next upstroke of the piston, as shown in diagram *D*, the exhaust valve is opened; and since on the power stroke all the energy has been taken from the expanding gases, they are blown out by the ascending piston through the exhaust valve, thereby clearing the cylinder for the reception of a charge of fresh mixture. Immediately the piston reaches its top center after expulsion of the gases, the inlet valve is opened again and the cycle of operations is repeated, whereby continuous action is obtained.

It will be seen that in the accomplishment of one complete cycle, the piston has made four complete strokes lengthwise of the cylinder. It went down once on the inlet or suction stroke;

up once on the compression stroke; down again on the power stroke, and up once again on the exhaust stroke. From the fact that four such piston strokes are necessary, an engine operating on this principle is called a "four-stroke-cycle" engine, or in more common parlance, a four-stroke engine. There are internal combustion engines which operate on other cycles; there is one, for instance, which accomplishes its entire function in two strokes of the piston. But for tractor service engines operating on any but the four-stroke-cycle have made no progress, however serviceable they may be in other fields, so that a description of their operation in a book dealing strictly with modern tractor engine practice will serve no useful purpose.

The reader, in going over the diagrams picturing the cycle of operations, will also notice that in going through one complete cycle the crankshaft made two complete revolutions. There is, then, one power stroke to each four piston strokes with a single cylinder engine of this type, and the flywheel must be so proportioned as to carry the piston through three idle strokes after each power stroke before the piston is again in position to impart power to the engine crankshaft.

If we were to actuate the valves directly from the crankshaft, it must be evident that each valve would open once for each revolution of the crankshaft. As a matter of fact, as we can prove for ourselves by referring once again to the diagrams, the inlet valve opens only once for each two revolutions of the crankshaft, and the exhaust valve has a similar movement. The exhaust valve is open for one-half of one revolution, the inlet valve for the second half of the same revolution, while for the second revolution both are shut tight.

It would not do, obviously, to open them directly from the crankshaft; we must interpose a second shaft timed to rotate at half the speed of the crankshaft in order to obtain the proper motion of our valves relative to the piston travel. The arrangement of this shaft, which we call the "camshaft," is indicated in Figure 4. It will be seen that a gear wheel is mounted on the crankshaft, engaging with a second gear of twice the diameter of the crankshaft gear mounted on the camshaft, the relative sizes being such that the camshaft rotates at half crankshaft speed.

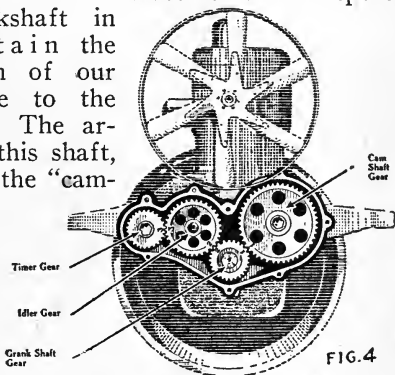

Fig. 4. Showing how the camshaft is driven at half crankshaft speed.

ing with a second gear of twice the diameter of the crankshaft gear mounted on the camshaft, the relative sizes being such that the camshaft rotates at half crankshaft speed.

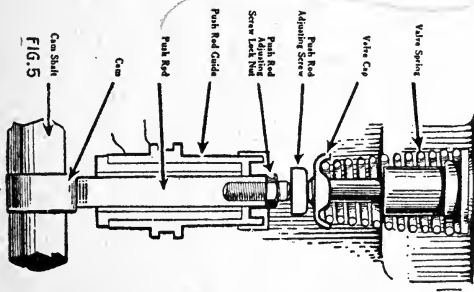

Fig. 5. Action of cam in opening the valve.

On the camshaft is mounted an irregularly-shaped wheel—a wheel with a hill on it and called a cam—for each valve. Every time the

hill on the cam comes around, it raises the valve push-rod (see Figure 5), which in turn pushes up against the bottom of the valve stem and elevates the valve against the action of the valve spring. When the hill passes, the valve spring returns the valve to its seat. Where the valves are of the overhead or "valve-in-head" type, the push-rod is longer and transmits its motion to a rocker arm or lever which bears down against the valve stem, opening the valve at the proper time.

Naturally, the hill on the cam is exactly proportioned to start opening the valve at the proper time and to hold it open just long enough; and the cams are so set on the camshaft as to time their performance correctly with the piston travel.

CHAPTER II.

Features of Construction.

Wherein Multi-Cylindered Engines Excel for Tractor Work and the Standard Types Offered.

IN the preceding chapter we have gained an insight into the basic principles upon which the tractor engine operates. In the employment of these basic principles, all tractor engines are identical—in their details of construction, however, they differ radically from one another. It is the purpose of the second chapter to go fully into modern tractor engine construction, indicating the functions of the various parts and indicating clearly wherein one engine differs from the next and the reasons therefor.

We have had under consideration so far only such engines as employ a single cylinder. It must be evident that on a vehicle like a tractor, where smooth progress is desirable, the production of power in "jerks" such as we have seen results from the single-cylinder construction, is by no means ideal. It would be far better, for instance, if instead of obtaining only one power stroke for each two revolutions of the crankshaft, we could obtain two power strokes; still better if we were able to get four power strokes, or one for each half revolution of the crankshaft. That means that we would obtain one power stroke for every 180 degrees of crankshaft movement.

It is quite impossible, of course, to obtain such desirable results from a single-cylinder en-

gine performing on the four-stroke cycle. It is quite possible, however, to arrange two such cylinders, or four such cylinders, to impart impulses to a single crankshaft; and by properly arranging the crankthrows, and the cams, to cause these cylinders to deliver their power to the crankshaft at different times.

Such is the trend of modern tractor engine practice; single-cylinder engines which once were almost universally used for tractor work are fast becoming obsolete; the two-cylinder engine still persists on several well-known makes of tractors, but even it is giving way at the present time to the four and six-cylinder types which have made such great headway in the automobile field and which are fast becoming standard in the tractor industry.

The four-cylinder engine is by far the most popular at the present writing, there being very few engines of a greater number of cylinders; and since the flexibility which we demand in the passenger automobile is by no means essential to tractor service, it seems altogether likely that four cylinders will be the accepted standard of the future tractor engine. It is worthy of note that in only a single instance has a greater number of cylinders than six been adopted—that is, in the case of the Common Sense tractor produced on the Pacific Coast and which employs a Herschell-Spillman engine with eight cylinders.

Indicative of the fact that for all the progress made toward the multi-cylinder engine, the single-cylinder type is not as yet a dead issue, nor its production confined to the smallest manufacturers, are the accompanying photographs of typical engines of that type produced by two of the largest tractor builders in the country.

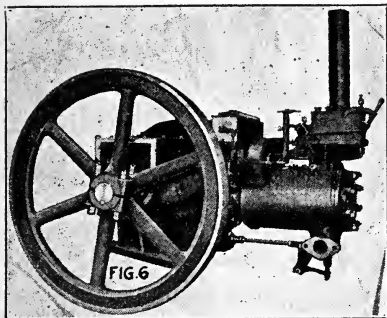

Fig. 6. Single-cylinder horizontal engine on 18-35 Rumely.

Figure 6 represents the single-cylinder horizontal engine employed on the model 18-35 tractor produced by the Advance-Rumely Tractor Co., La Porte, Ind., which has given a re-

markable account of itself over past years, while Figure 7 pictures a somewhat similar type of engine, which is used on the 10-20 Mogul tractor produced by the International Harvester Corporation.

It will be noted in the case of the latter that the valves are placed in the cylinder head, and that the engine is "hopper" cooled. A modified "T"-head cylinder arrangement prevails in the case of the Rumely engine.

Not always, in the case of the single-cylinder engine, is the horizontal cylinder arrangement adhered to. Take, for instance, the *Beeman* garden tractor, which is a small hand-

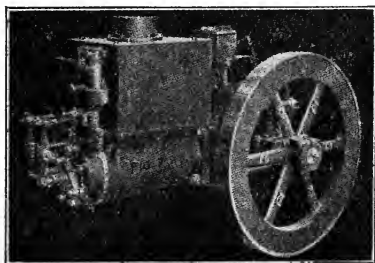

Fig. 7. Mogul 10-20 single-cylinder engine.

operated machine, and a vertical cylinder engine of this type is employed.

Two-cylinder tractor engines, which still are commonly met with throughout the industry, come in three different forms as to the arrangement of the cylinders. The most commonly met with is the "opposed" cylinder type, with two horizontal cylinders facing each other on a single crankcase. Such an engine is pictured in diagrammatic form in Figure 8, with the various

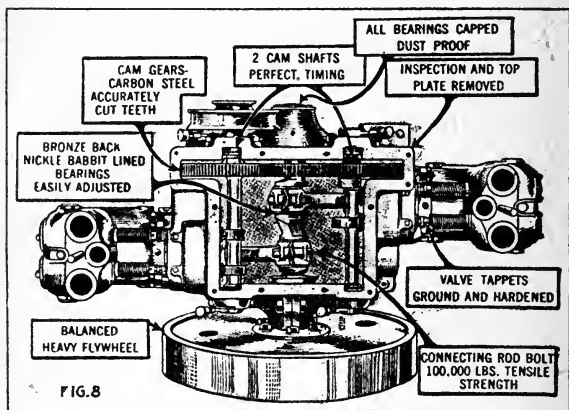

Fig. 8. Two-cylinder opposed engine of the Bull Tractor.

parts indicated for the convenience of the reader. The engine in the figure is the one employed on the Bull tractor, a three-wheeled type which is held in great respect.

The real virtue of a two-cylinder engine of this type is the close approach to perfect balance which the arrangement of the various parts permits. It will be appreciated that with the single-cylinder engine the sudden stopping and starting

of the piston at each end of its stroke entails considerable vibration, which is registered on the entire tractor mechanism. With a view of eliminating this fault to the greatest possible degree, makers of this type of engine attach counterweights to the crankshaft at points opposite the crankpin in order to balance the weight of the reciprocating members—the piston and connecting rod assembly. This arrangement is clearly indicated in Figure 9, which shows a crankshaft and piston assembly from an engine of this type.

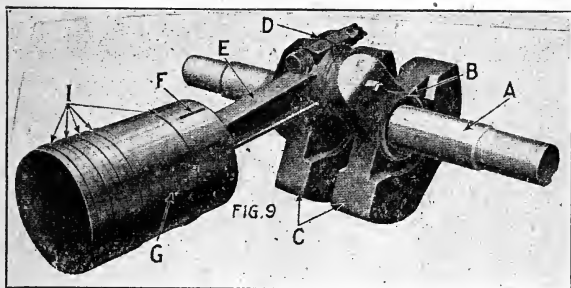
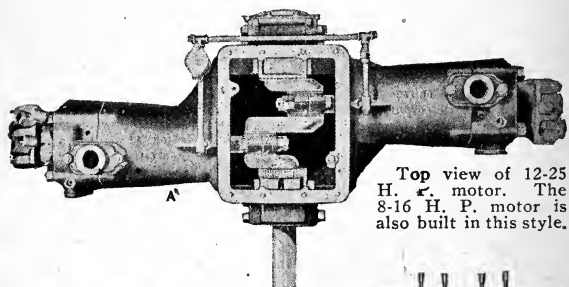

Fig. 9. Counterbalanced single-cylinder crankshaft (Mogul 10-20).

In practice, however, it has been found impossible to achieve perfect balance of the reciprocating members by means of rotating counterweights, and while the latter do a measure of good, the results obtained are by no means perfect. If, however, we apply to the crankshaft, exactly opposite the crank, a reciprocating mass exactly equal and similar to the piston and connecting rod, the vibrations set up by this balancing mass will exactly counterbalance those engendered by the piston movement, and smooth operation of the engine will be promoted.

As can be seen by the illustration (Figure 8)

in the two-cylinder opposed engine, the piston and connecting rod of the second cylinder are so arranged as to take the place of this counterbalancing mass, the crankthrows being set at 180 degrees apart. Hence, the vibratory forces



Top view of 12-25 H. P. motor. The 8-16 H. P. motor is also built in this style.

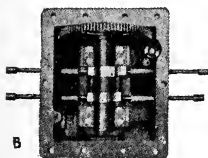

Cam case on 12-25 H. P. motor.

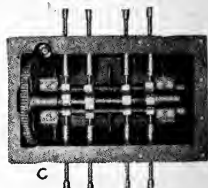

Cam case on 25-50 H. P. motor.

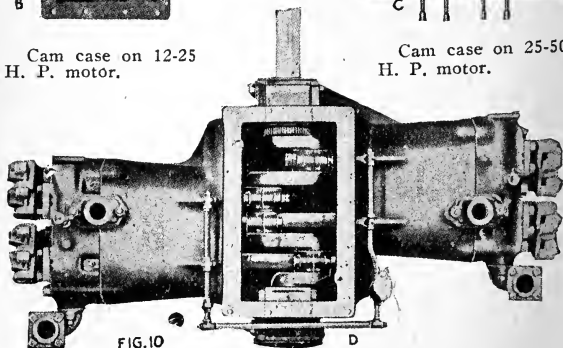

FIG. 10

Top view of 25-50 H. P. motor. The 18-36 and 40-80 H. P. motors are also built in this style. Note how narrow this four-cylinder motor is and how strong in construction.

Fig. 10. Some views which emphasize the features of Avery engines.

set up by one piston occur at exactly the same time, are equal to and in the opposite direction from those established by the other one, so that they neutralize each other, and perfectly smooth operation is the result. It can plainly be seen that the use of counterbalances on the crankshaft of such an engine is needless.

In Figure 10 are shown similar views of the Avery tractor engine of the opposed type in both two-cylinder and four-cylinder types. The main points of divergence between the Bull and Avery two-cylinder engines are the employment of L-head cylinders with direct acting thrust valves on the former, as against the I-head cylinder with valves in the head by the latter; also in the Avery a single camshaft is employed to time the action of all four valves, while in the Bull engine the employment of two camshafts is indicated.

In connection with the Avery tractor it may be said that this manufacturer has adhered to the opposed type of engine for many years and developed that type to a point of refinement that is hard to improve upon. In the four-cylinder Avery job still another source of vibration is eliminated. It will be noticed that in the two-cylinder engine the cylinders are "staggered" slightly, due to the arrangement of the throws on the crankshaft. Because of this staggering it is evident that the pull of one rod on the crankshaft, due to the piston stoppage, is delivered at a different place from the pull of the other rod and is opposite in direction. This will cause the crankshaft to act somewhat like a lever, influencing it to rotate in a longitudinal plane about a center midway between the points of attachment of the two rods to the shaft. Since there is a reversal of movement of the pistons twice

for each revolution of the shaft, and since such reversal will cause a tendency for the longitudinal rotation of the shaft to reverse also, we have a source of an annoying vibration which is very evident at high engine speeds.

If, now, we note the arrangement of the crankthrows on the four-cylinder engine, we find that those on the two outside cylinders are on the same plane, while those on the two inside cylinders are 180 degrees away, both rods, in fact, attaching to the same pin. If we consider the action of the two outside pistons

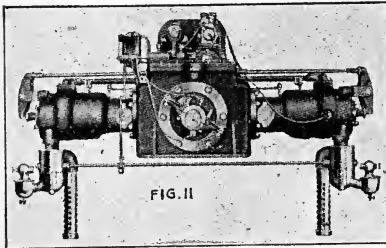

Fig. 11. Ingeco engine of the opposed type.

at the moment of reversal, we find that both are acting in the same direction, so that if the shaft were fulcrumed on a center the resulting forces would

counterbalance each other and would not tend to cause rotation of the shaft in a longitudinal plane as with the two-cylinder engine. Likewise, the forces which would tend to cause such rotation from the inside cylinders are exactly counterbalanced. At the same time, the two pistons on one cylinder block exactly balance those on the other block, so that all reciprocating forces are balanced, and an engine which is perfectly balanced under all conditions results.

In Figure 11 is shown a photograph of still another opposed two-cylinder engine, which is fitted to the Ingeco tractor. It also is of the

overhead valve type and its chief claim to novelty is in the fitting of two carburetors, whereby the necessity for a long intake manifold entailing condensation under cold weather conditions is done away with. Figure 12 gives a side view of the two-cylinder Avery engine making plain the use of long manifolds. In the illustration a double-bowl carburetor is shown, one bowl serving for gasoline and the other for kerosene; the shift from the lighter to the

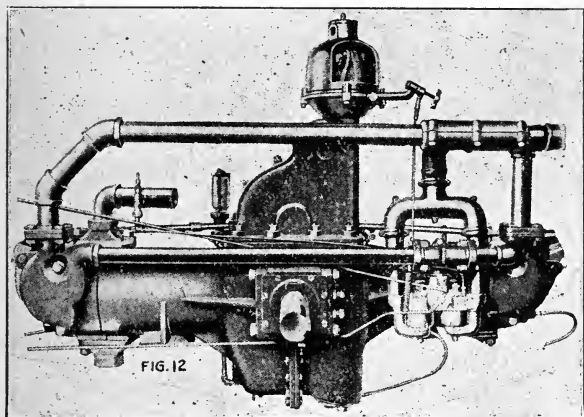

Fig. 12. Side view of the Avery double-cylinder type.

heavier fuel is made when the engine has become sufficiently warmed up to handle the kerosene properly.

It cannot be denied that the double-cylinder horizontal engine has certain advantages in the way of compactness over the opposed type, and these advantages have led to its adoption in preference to the opposed engine by several tractor manufacturers. These advantages are

mainly a greater facility with which the various fuel, water, oil and exhaust connections can be made and the fact that such a cylinder arrangement permits of the two cylinders being cast together in a single block, making for rigidity and lessened cost of production.

Such an engine is the Titan 10-20, used on one of the International Harvester models. It is pictured in Figure 13 and like the Avery, is of

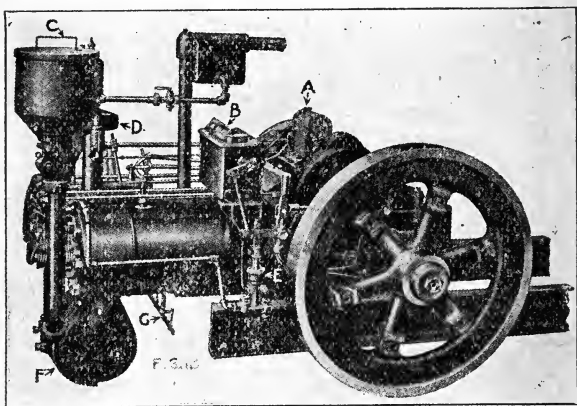

Fig. 13. Engine of Titan 10-20.

the overhead valve type. The chief drawback to such an engine is the inability to obtain perfect balance, or even a close approach to perfect balance, if the firing intervals are made equal. In order to bring about the latter condition, for instance, on a two-cylinder engine, it is evident that we will want one power impulse for each crankshaft revolution, or 360 degrees of crankshaft movement. That means that both pistons must be attached to the same pin or to pins on the same plane, so that they will travel together,

for if they were mounted 180 degrees apart, as in the case of the two-cylinder opposed type, it is evident that rotating the shaft 360 degrees after the first cylinder has fired will result in the second piston being at the bottom of its stroke and in no position to fire. The only way to have it in position to fire 360 degrees after the first cylinder is to mount it on the same pin, and this is the practice usually followed.

This practice, however, gives us two reciprocating masses

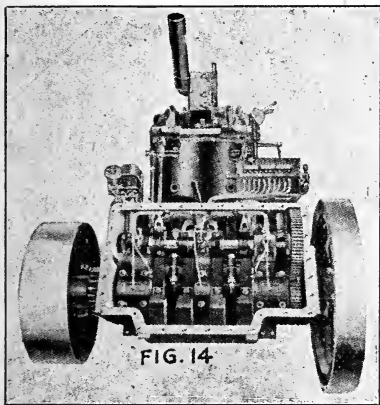

Fig. 14. A Rumely two-cylinder horizontal type where balance has been sacrificed to obtain even firing intervals.

w o r k i n g
in unison and
not opposing
each other,
and it is evi-
dent, there-
fore, that the
vibration en-
tailed will be
twice as great
as in the case
of a single-
cylinder en-
gine with the
same recipro-
cating masses
and turning
up at the

same speed. The means taken to offset this condition, of course, are the attachment of counter-balance weights to the crankshaft, as shown by Figure 14, which illustrates a Rumely engine of this type. The inability to obtain perfect balance by this method has been made clear before; it is evident that such an engine, due to its tendency to vibrate badly, is suitable for low rotative speeds only.

In the Rumely 14-28 engine the other alternative has been taken and even firing intervals

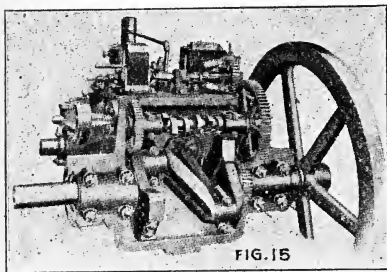

Fig. 15. Crank-case with cover removed from Rumely 14-28 engine.

have been sacrificed in order to attain an engine of better balance. In this case the crank-throws are set 180 degrees apart so that one cylinder fires 180 degrees

after the other, and then there is a complete crankshaft revolution with no power impulse. With this arrangement, which is shown in Figure 15, it is evident that the reciprocating mass of one piston almost exactly counterbalances the other; there is a slight difference at certain points in the stroke due to the difference in rate of acceleration and deceleration which results from the angularity of the con-

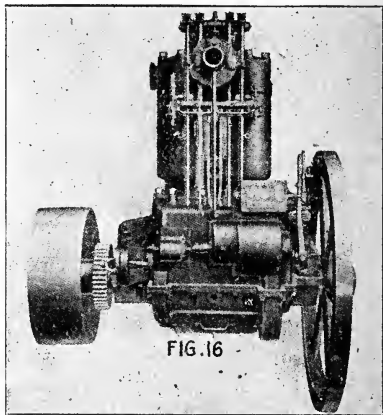

Fig. 16. Top view of the 14-28 Rumely motor.

necting rods; however, balance in the line of the cylinder axii is almost perfect.

It will be seen, however, that whereas with the opposed type of engine it was simply necessary to stagger the cylinders slightly to give clearance, the side by side arrangement of the cylinders in this case makes the points of attachment of the two rods quite far apart—much further than in the case of the opposed type. Considering longitudinal balance with relation to the crankshaft, therefore, the engine is greatly at a disadvantage. This fact has been offset in the engine under consideration by the attachment of counterweights on opposite ends of the crankshaft and 180 degrees apart. The vibrations created by these counterbalances tend to offset those created by the piston movement and give a smooth-running motor.

While the irregular firing of this engine is by no means the ideal condition, in practice it has not been found to work out greatly to the disadvantage of the unit as a whole. That this is so is attributable to the fact that the flywheel used is sufficiently heavy to carry the engine shaft over at substantially constant speed, storing up the energy from the two power strokes on the first revolution and giving it back to the shaft on the second revolution when there is no power stroke. The two cylinders fire, of course, 180 degrees apart, there being a lapse of 360 degrees after the second one fires before the first one fires again. X

The peculiarities of tractor design and the total lack of standardization prevailing throughout the industry have given rise to many constructions which either never were common with the automobile engine, or at least never survived the experimental stage. One of these is

the four-cylinder engine, with the cylinders all in a line and placed horizontally instead of vertically.

The virtue of an engine of this type is, of course, the fact that it lends itself readily to proper placement in the frame of the tractor without bringing any of the machine too high; at the same time it makes an engine which is very accessible, since not only the valve mechanism, which is generally exposed and located on top of the cylinders, but also the bearings can

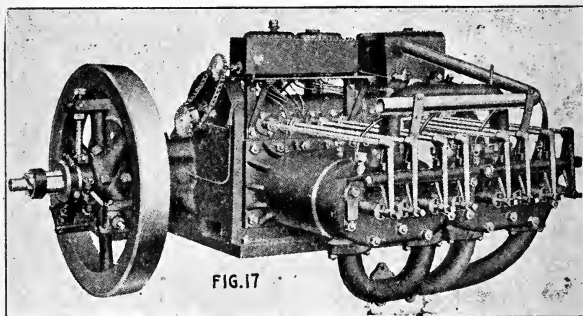

Fig. 17. Four-cylinder horizontal engine of Aultman-Taylor 30-60 model.

be reached in a jiffy when it comes time to effect adjustments or repairs.

That this is so is made evident by Figure 17, in which is illustrated the engine of the Aultman-Taylor 30-60 tractor. The facility with which any part of the valve mechanism can be reached—as will be seen, the valve-in-head arrangement is adhered to—the ease with which the cylinder heads can be removed from the two cylinder blocks and the otherwise generally accessible location of the engine parts and accessories are plainly obvious.

Figure 18, on the other hand, gives a very fair indication of the facility with which every bearing in the engine can be reached, giving ample room for relining, taking up on slack bearings or withdrawing the entire piston and connecting rod assembly when it is necessary to refit piston rings, renew the pistons or otherwise correct faults or improve the operation of the engine. The base or crankcase casting of the engine is split diagonally, as shown, and simply

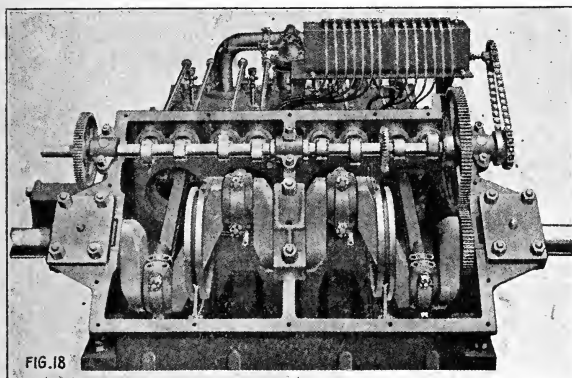

Fig. 18. Showing the accessibility of the internal mechanism of Aultman-Taylor 30-60 engine.

undoing the cap screws with which it is fastened in place discloses the entire inner working mechanism of the engine, and it all can be reached from above; it is not even necessary to drain the crankcase of the oil, as would be necessary with the vertical cylinder engine.

The crankshaft employed is of the three-bearing type which is commonly met with on four-cylinder engines, both horizontal and vertical cylinder types; and it will be seen that the

two outside crankthrows are on a plane, and the two inside on a plane 180 degrees away. The effect is that we have perfectly even firing intervals, one cylinder firing at each half revolution of the crankshaft, or at each 180 degrees; while at the same time we have a very close approximation of perfect balance. It will be seen, for instance, that the reciprocating masses of the two inner cylinders are opposed to the reciprocating masses of the two outer cylinders, so that except for a slight difference in piston velocities at certain crank positions, due to the angularity of the connecting rods, both weights and velocities are equal on the two sets, but the direction of movement of one set is opposite that of the other, so that balance is obtained. Considering longitudinal balance, the effect of the two front-cylinder reciprocating masses is exactly counteracted by that of the two rear ones, so that vibration from this score is done away with.

As tractor design progresses toward some accepted standard—and such progress has been marked over the past three years—the vertical cylinder type of four-cylinder engine, following closely automobile practice, comes more and more into its own. In fact, even the six-cylinder vertical cylinder type is making some progress.

Doubtless there will always be quite some difference between the tractor engine and the accepted automobile standard; difference which results from their different fields of employment and the widely divergent duties they are called upon to perform. Chief among these differences will be the weight, since it can easily be believed that the tractor engine will, for at least some time to come, represent a heavier construction for equal power output than the automobile type—this difference being due to the fact that the trac-

tor engine operates normally at three-quarters load constantly throughout the day—it is essentially a constant-duty engine and, as such, probably always will be of the moderate speed type and rather rugged in construction.

The automobile engine, on the other hand, is called upon to deliver power at only one-quarter its rated capacity throughout the greater part of the day; but for brief intervals it may be taxed to its limit or to any extent between maximum and minimum power development possibilities. It is essentially a variable load engine, and since the vehicle it is used in connection with must be capable of high speed and rapid acceleration, light weight, in conjunction with great power, is a prime essential. Quite as a matter of course, the automobile designer has gone to high rotational speeds in order to satisfy these conditions.

Flexibility and quick pick-up, on the other hand, are not required of the farm tractor—what is wanted is a slow, steady pull with great durability. Hence we can logically expect that power for power, the tractor engine will be weightier and slower-moving than the automobile engine.

There are but a handful of tractor engines which violate this condition. First and foremost comes the Moline Universal, which employs a four-cylinder engine of the high-speed type which is comparatively light in weight, but withal very rugged in construction. Second is the Fordson, also employing an engine which turns over at a speed comparable with the average automobile engine. But perhaps the most noticeable exception to the rule is the Common Sense tractor, which is a Coast production and which employs an eight-cylinder V-type engine, following exactly automobile engine practice.

That ruggedness and heavy weight are the

rule, however, is made plain in some of the vertical cylinder engines pictured herewith. Figure 19, for instance, illustrates the four-cylinder vertical engine employed on the Emerson-Brantingham (Reeves) tractor, rated at 40 horse-power, for belt work. Indicative of ruggedness is the five-bearing crankshaft, a construction which has all but disappeared from automobile practice, and the employment of separately-cast cylinders.

The value of the latter construction on tractor work is not to be minimized. The tractor engine

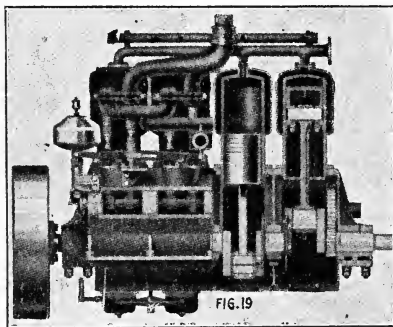

Fig. 19. Cross section of E-B (Reeves) 40-65 kerosene motor.

operates under totally different conditions from the automobile engine and the fact that its work is of the hardest, and long continued; that its temperatures run high and lubrication is

therefore difficult; and that sufficient attention is, unfortunately, not always paid to the necessity of keeping the air washer in prime condition, so that no grit will get into the cylinders, results in more frequent scoring of one or more cylinders, necessitating either replacement or reboring. With the individually-cast cylinders the correction can be made at greatly reduced cost, and in much less time than when the cylinders are cast in a single block, necessitating the removal of re-

placement of the entire block in accordance with the amount of damage done.

This construction quite naturally gives a particularly long engine; much longer than an engine of the same cylinder dimensions but with the cylinders cast in pairs or in block. But this additional length is not an altogether bad feature. It gives much greater clearance within the engine, greatly facilitating the removal and the replacement of the piston and connecting rod assemblies, etc. At the same time, considering again the high prevailing temperatures, it is a well-known fact that the individually cast cylinders make possible the employment of cooling jackets of substantially equal cooling capacity at all points around the cylinder, so that warping of the cylinders resulting in misalignment of the working parts and greatly increased wear is, to a greater or less extent, done away with.

In the engine under consideration, the cylinder heads are cast with the cylinders and are not separable; and the valve arrangement is of the L-head type. The sectional view of the two forward cylinders clearly indicates the symmetry of the water jackets as pointed out above. The cylinders are provided with flanges at the lower ends and through these flanges pass the cylinder hold-down bolts by means of which the cylinders are held firmly in place on the crankcase casting. In tractor practice, due, of course, to the fact that reduced weight is not of prime importance, the crankcase is, in almost all cases, formed of cast-iron instead of aluminum, which is usually employed on automobile engines. This fact is of greater importance in the case of an engine fitted with individually-cast cylinders than is so with the cast-in-block type, for the very good reason that with the latter the cylinder block

itself acts as a stiffening truss to give rigidity to the entire engine structure; while in the latter case this function must be performed in its entirety by the crankcase casting, together with the crankcase lower half.

It will be noticed also that the individually-cast cylinder construction necessitates the employment of separate manifolds for the introduction of the mixture into the cylinders, for the exhaust of the spent gases from the cylinders and for the intake of the water to the jackets and the outlet of the water from the jackets to the radiator.

From this standpoint the construction is not equal to the cast-in-block arrangement wherein it is perfectly possible to mold the entire set of gas and water passages so as to

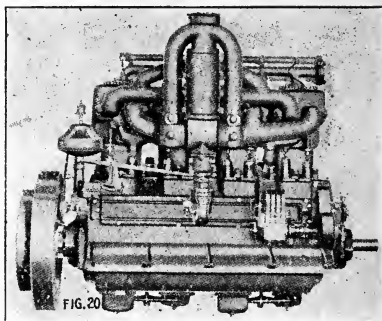

Fig. 20. $7\frac{1}{4} \times 9$, four-cylinder Twin City oil engine. Valve side.

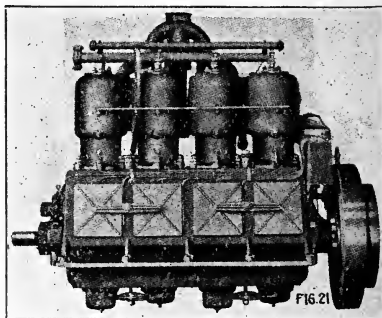

Fig. 21. $7\frac{1}{4} \times 9$ four-cylinder Twin City oil engine.

be incorporated within the single casting. While the casting of such a block is quite a costly operation, machining is simplified, assembly greatly simplified, and the number of parts greatly reduced, so that in the final analysis the cast-in-block construction is undoubtedly the cheaper.

In Figures 20 and 21 are illustrated two views of the Twin-City oil engine as employed on one of these famous tractors. It will immediately be noted that the construction of this engine is not greatly different from that of the Reeves engine just described, the most noticeable differ-

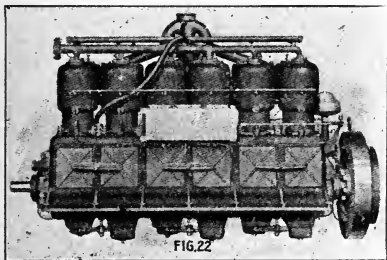

Fig. 22. 7 1/4 x 9 six-cylinder oil engine.

ence being found in the arrangement of the manifolds. The peculiar arrangement, as indicated on the Twin-City engine, has been adopted primarily with a

view of facilitating the burning of heavy fuel such as kerosene; the arrangement is such that some of the exhaust heat is utilized to effect full vaporization of the heavy and less volatile ends of the fuel so that a mixture which is readily ignited and burns to completion is supplied to the engine cylinders. As will be pointed out in the chapter bearing on carburetion, it is in the arrangement of the passages to effect this purpose that are discovered one of the chief lines of divergence in tractor engine practice.

It was noted before that six-cylinder engines were commonly met with in tractor work and

the Twin-City line is one of several in which this type of engine is employed. The Twin-City Six is illustrated in Figure 22 and will immediately be recognized as exactly the engine described above with the addition of two more cylinders. It is because the individually-cast cylinder arrangement makes possible the expansion of a four-cylinder engine into a six-cylinder job in this manner with the use of parts which are interchangeable, with a very few exceptions,

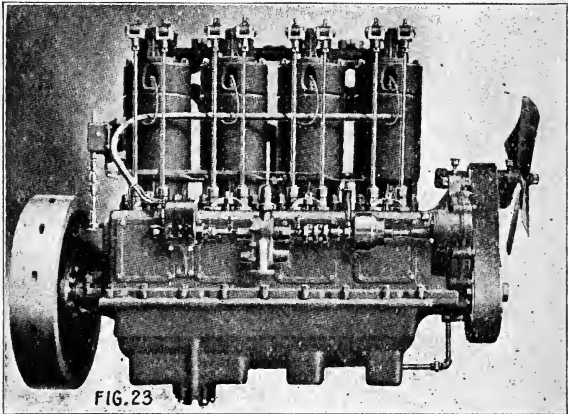

Fig. 23. The Tracklayer Motor is the valve-in-head type, long established as the most powerful design of gas motor. It is built along simple lines to stand the test of work and time.

with those of the four-cylinder engine that many tractor manufacturers prefer this construction. All of the parts on this six-cylinder engine, for instance, with the exception of the crankshaft, crankcase, camshaft and manifolds, are perfectly adapted to the four-cylinder engine. The crankshaft, of course, is of the 120 degree type, and is mounted on seven bearings.

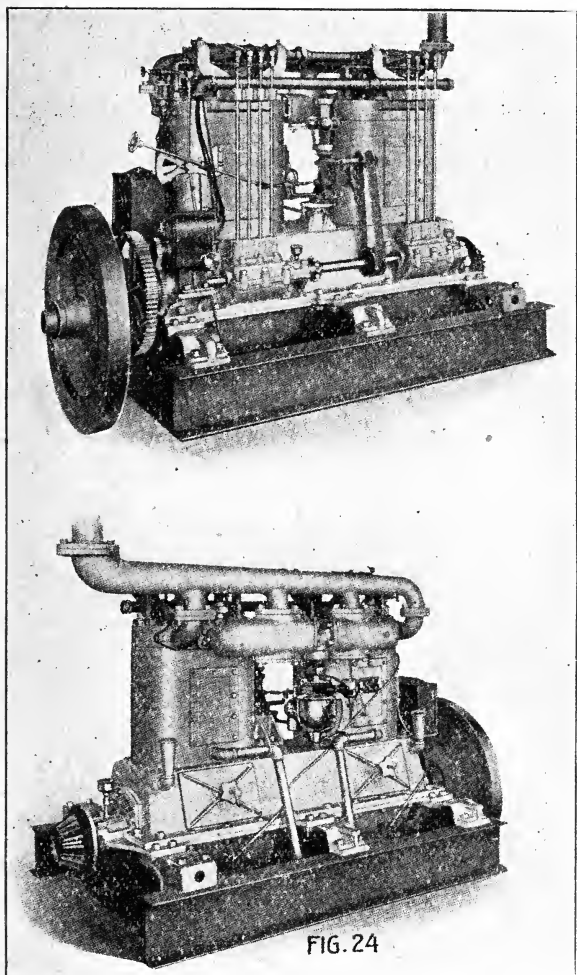

FIG. 24

Fig. 24. Two views of the Flour City engine.
Above—Showing camshaft side of motor.
Below—Showing manifold side of motor.

Still another example of the individually cast cylinder arrangement on a four-cylinder vertical motor is given in Figure 23. This is the Best Tracklayer engine employed on the larger of the two models put out by the C. L. Best Tractor Co. and is of clean-cut rugged construction. It will be noticed that the valve arrangement is of the valve-in-head type and that unlike the Reeves and Twin-City engines, the cylinder heads are cast separately and held in place by hold-down bolts or cap screws. This not only facilitates

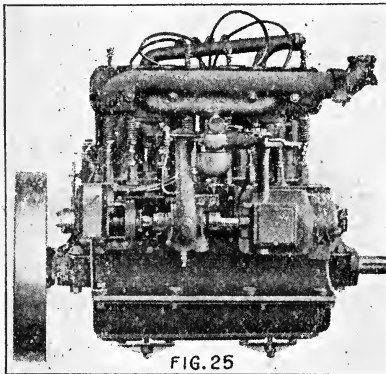

Fig. 25. The cylinders of the Neverslip engine are cast in pairs.

work incidental to the removal of carbon when this operation is necessary, but it also makes the frequently necessary task of valve grinding very much easier.

As a compromise, not a few manufacturers of four-cylinder engines prefer

to employ the cast-in-pair cylinder construction. Figure 24 illustrates both sides of the Flour City tractor engine which is of this type. It gives a very clean-cut engine, even despite the fact that outside manifolds are necessary, while at the same time the close-coupling of the two pairs of cylinders makes possible the employment of a three-bearing crankshaft instead of the five-bearing type called for by the individually-

cast arrangement, and adds materially to the stiffness of the construction, while at the same time reducing production costs. In cases where the cast-in-pair practice is adopted it is usual to include in the line of engines a two-cylinder model, a four-cylinder model and a six-cylinder model, all using the same cylinder blocks.

Like the Best engine, the Flour City engine is of the valve-in-head type, and is novel in that very large inspection plates are provided on both sides of the cooling jackets by means of which

cleaning of the cooling system can be effected to the entire satisfaction of the operator.

Another example of the pair-cast type is illustrated in Figure 25. This is the

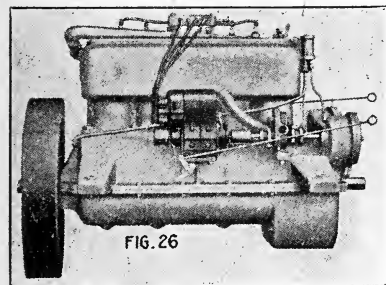

Fig. 26. Kermath engine used in Light-foot tractor.

engine employed on the Neverslip tractor, made by the Monarch Tractor Co., Hartford, Wis. It differs from the Flour City job materially, being of the L-head type with valves, manifolds, magneto, pump and governor all mounted on the one side of the engine.

The clean-cut, staunch design made possible by the cast-in-block arrangement is well illustrated in Figure 26, which pictures the four-cylinder Kermath engine employed on the smaller tractor put out by the Monarch Tractor Co. under the style Lightfoot. The engine, which is of the L-head type, is remarkably free

from complication in so far as external apparatus is concerned, which, of course, is distinctly a desirable feature.

Contributing greatly to this end is the fact that the single block casting, coupled with the L-head valve arrangement, makes it quite

a simple matter to enclose the valve mechanism entirely by means of a side plate or two as is indicated in Figure 27, giving a view of one of the Aultman-Taylor engines. In the illustration the forward valve-enclosing plate has been removed, disclosing the valve stems, springs and tappet mechanism of the two forward cylinders. Such enclosure is, of course, desirable from the standpoint of cleanliness, which means reduced wear; as well as from the standpoint of better lubrication of this important part of the engine mechanism. In most cases, for instance, the tappets and the valve stems are lubricated by an oil mist conducted into the valve

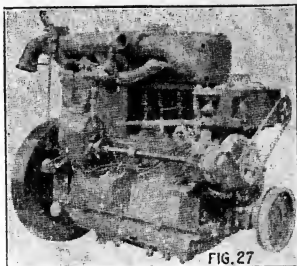

Fig. 27. 15 H. P. motor used by Aultman-Taylor.

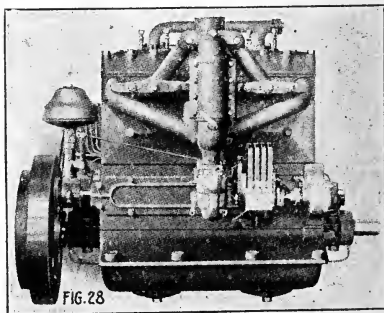

Fig. 28. 6 1/4 x 8, four-cylinder Twin City oil engine. Valve side.

chamber from the crankcase through suitable drillings or through holes bored in the hollow tappets, providing a sufficient amount of oil for the purpose. This, too, means reduced wear and higher efficiency.

Contrasting the Twin City engine shown in Figure 28 with those illustrated in Figures 20 and 21 shows clearly the trend of design. The 6¼ by 8 inch engine shown in the last figure is a later production and incorporates many features of design not found in the earlier types, such, for instance, as the enclosed valves, the block-cast cylinders and the separable cylinder head. Quite naturally, the over-all length of the engine, due to the compact cylinder arrangement, is greatly reduced, as a comparison of the two types offered by Twin City clearly indicates.

It might be well to point out at this stage that the manufacturer of the Twin City line of tractors is one of the most progressive in the industry. The later models of the Twin City tractors, which are giving a remarkable account of themselves in the field, and especially at the tractor demonstrations throughout the country, are so far in advance as to be equipped with "double" valves; that is, two inlet valves and two exhaust valves to the cylinder, closely following aviation engine practice. Thereby greater area is obtained than is possible with the single valve arrangement, and the flow of the gases is correspondingly facilitated. This, in turn, results in a marked power increase and cooler operation; not the least important improvement in the operation, however, and one that is immediately apparent and highly important, is the fact that these engines will throttle down and idle on kerosene fuel in a manner that leaves but little to be desired. It is lamentable, but true, that

this much cannot be said for all kerosene engines employed in modern tractor construction.

Also reflecting modern practice to a marked degree is the engine illustrated in two views in Figure 29, employed on the Emerson-Branting-

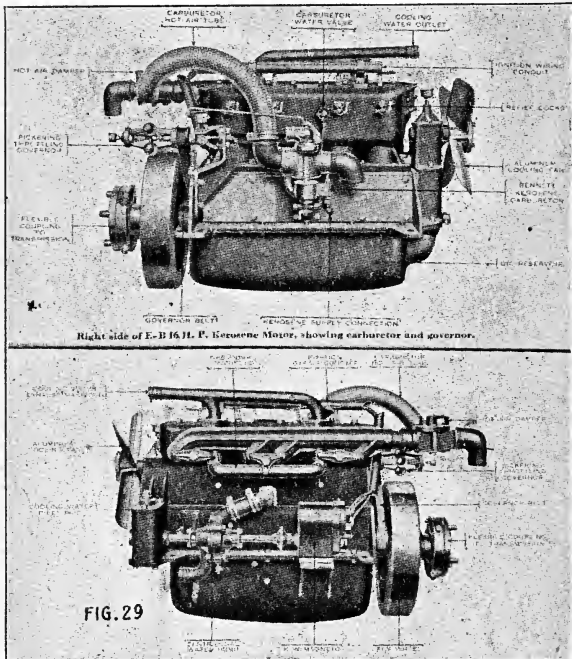

Figure 29. Emerson-Brantingham Engine.

Above—Right side of E-B 16 H. P. kerosene motor, showing carburetor and governor.

Below—Left side of E-B 16 H. P. kerosene tractor, showing magneto, pump and manifolds.

ham 16. It will be seen, in the lower view, that the valves are fully enclosed by a single plate, the valve arrangement being of the L-head type.

One of the factors which has contributed greatly to the rapid advancement of the automobile was the coming of the parts specialist—the manufacturer with plant equipped to make motors,

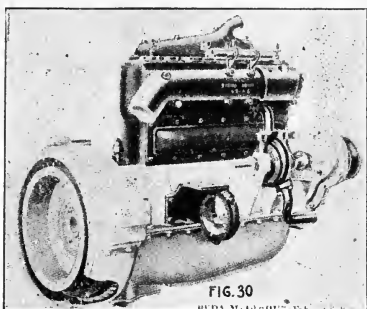

Fig. 30. Buda Model "HU" (exhaust side) $4\frac{1}{4}$ in. x $5\frac{1}{2}$ in. (107.94 x 139.66 MM.)

and who concentrated on motors and developed an engine that matched the best; similarly the manufacturer who specialized on transmissions, axles, carburetors, magnetos, etc., etc. These specialists could well afford to employ the best of talent in their particular lines, talent that the average automobile manufacturer could not begin to hire; as a result, the industry as a whole progressed by leaps and bounds.

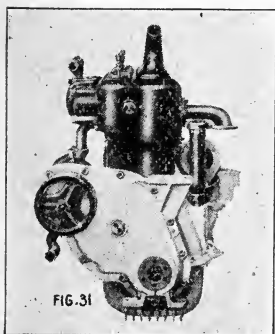

Fig. 31. Buda Model "HU" (end view) $4\frac{1}{4}$ in. x $5\frac{1}{2}$ in. (107.94 x 139.66 MM.)

It is not hard to predict that the entrance of the specialist into the field of tractor production will have a similar elevating effect. At the present stage of the industry, the special manufacturer of engines adapted particularly for tractor service has gained a firm footing and tractor engine design is making

marked progress.

One of the most important stock engine manufacturers is the Buda Co., of Harvey, Ill. — well known also as automobile engine manufacturers—

and one of its typical tractor engine offerings is illustrated in Figures 30 and 31. It is a four-cylinder, block-cast, L-head job, clearly reflecting the best that automobile engine practice affords and is being successfully used by dozens of tractor manufacturers. Its clean-cut appearance and apparent simplicity are its major appeal.

Figures 32 and 33 illustrate the Waukesha engine, which is another of the stock engine jobs which is a big factor in the industry. It

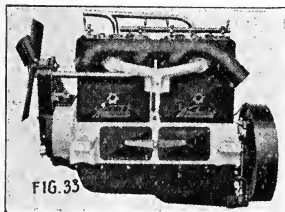

Fig. 33. Waukesha Motor used in the Nilson Senior.

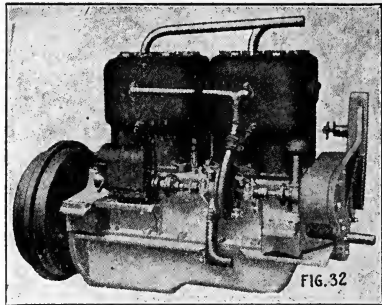

Fig. 32. Waukesha tractor engine.

also is a four-cylinder, L-head engine with the valves fully enclosed; the cylinders, however, are cast in pairs instead of in a single block, as was the case with the Buda engine.

Some of the other stock tractor engines of prominence are the Climax, Wisconsin, Buffalo, Beaver, Erd, Gile, Doman, Westman and Midwest.

CHAPTER III.

Major Engine Parts.

**Their Construction, Functions, Care and Repair
Fully Described.**

WHILE with some automotive engines in applications other than tractor work, material other than cast-iron or semi-steel may be used for cylinder construction, in tractor practice these materials only are employed. The reasons are not hard to find; the material—semi-steel is cast-iron with a certain proportion of steel added to give it toughness—is easily cast, easily machined, and when suitably designed and treated in manufacture will resist any tendency to warp under the heat and will carry all strains imposed upon it. It has still another, and an all-important virtue. This is the fact that there is present in cast-iron a certain proportion of graphite in combination with the metal itself. Under rubbing action the smooth cylinder bore assumes a high polish and a tough film forms which resists wear to a remarkable degree.

In almost all cases, as was made plain in the preceding chapter, the cylinder cooling jacket is cast integral with the cylinder itself and the modern tendency is to form all cylinders in a single casting with integral jackets and manifolds. The removable cylinder head, however, bolted to the top of the cylinder casting is taking on a significance it never had before, and many manufacturers are incorporating it in their designs. Such a cylinder casting with removable

head is shown in Figure 34, from one of the Rumely models.

In the past it has been common practice to rough-bore the cylinders and ream them to a finish, which although not perfectly smooth, soon assumed a polish under the piston action. This practice, however, is fast giving way to the grinding process, which leaves the cylinders with highly polished and perfectly true round walls, greatly facilitating fitting the pistons with the proper clearance and checking any tendency for oil pumping and gas "blow-by" when the engine

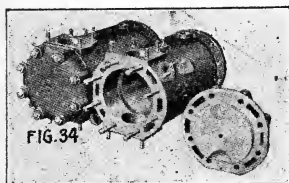

Fig. 34. Rumely cylinders and cylinder head.

is in operation. With a large number of the stock engine manufacturers, it is also common practice to "weather" the cylinders for some months after the first machining operation. This means that the cylinders

are allowed to age in the open, which has the effect of relieving any internal strains set up as a result of the casting process and the machining process, and which entail warping of the cylinders and wear.

Care of the Cylinders.—Provided the engine is treated with a fair degree of consideration, especially as to proper lubrication, the wear on the cylinders will be comparatively slight and altogether negligible for the first season or two. When the cylinders do show signs of wear, provided it is even throughout the length of the bore, and on all sides—such a condition is very rare because of the variation in piston pressure against the walls at different parts of the stroke—

correction can be effected by fitting oversize pistons supplied by the manufacturer a few thousandths of an inch larger than the ordinary piston.

To fit the new pistons properly it will be necessary to take the engine down and lap the cylinders with an expanding lap, which can be very easily made as illustrated in Figure 35, from one of the old pistons. The abrasive material for this work is a mixture of very finely ground glass and machine oil. It should be used sparingly. The proper lapping motion is a combined twist and up - and - down stroke throughout the entire length of the cylinder,

so that all parts of the walls will be evenly ground; the lap should be turned from time to time to bring new surfaces into contact. The lap should be kept expanded and working until the force required to turn

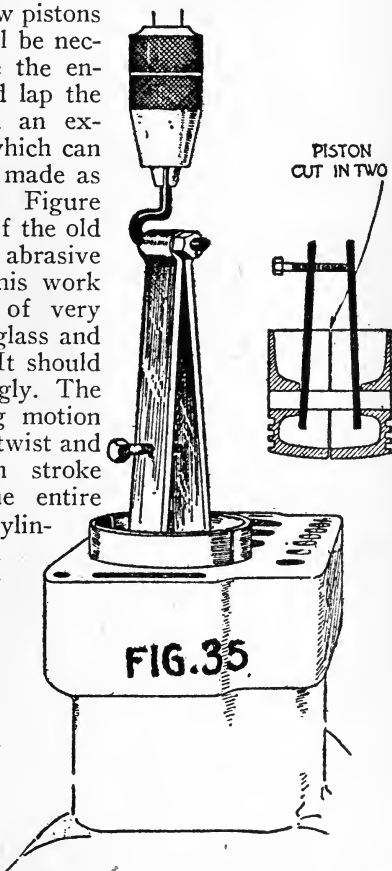

Fig. 35. Illustrating construction and use of an expanding lap for conditioning the cylinder bores after wear.

or move the lap is practically constant throughout the stroke. This shows that the cylinder is perfectly round. Care should be taken to see that all cylinder wall scores have been removed.

Where the cylinder walls are badly worn or are scored, due to lack of adequate lubrication, or the presence of some abrasive like sand, which has damaged the cylinder wall surface, reboring and fitting oversize pistons are necessary. Reboring a cylinder is a job which calls for special tools and for a practiced machinist to operate them in order to turn out creditable work. It is highly inadvisable for the average tractor owner or operator to undertake this work himself. The

best plan is to send the cylinder, or the cylinder block, as the case may be, to the nearest service station of the tractor manufacturer or to some compe-

tent tractor repairman who will make a proper job of it. The Avery cylinder can be readily relined as shown in Figure 36.

It sometimes happens that the piston pin will work loose and will chisel a slot in one or both sides of the cylinder wall too deep to be removed by reboring. Less frequently a piston ring will break and produce a like result, the sharp broken edge chiseling a groove in the wall. In such an instance a recently-developed welding process, called the Lawrence process, is invoked to fill up the groove, the excess metal then being ground

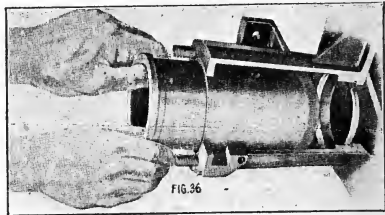

Fig. 36. Cylinder cut out to show how the Avery inner cylinder wall may be removed.

flush and lapped to a surface true with the balance of the cylinder wall. This also is a job for the expert; when it is employed, unless the cylinders are badly worn, it is usually not necessary to fit oversize pistons.

In the case of a cracked cylinder, due to neglect in winter, with consequent freezing of the cooling water and cracking of the cooling jacket, welding is the accepted means of effecting a permanent repair. Care should be exercised in the selection of a competent welder for this work, as a man who is inexperienced in handling his torch will warp the cylinder or the block out of shape and ruin it for further use. A good welder, however, can make a very satisfactory repair even on a very badly cracked cylinder.

There are several compounds now on the market for mixing with the cooling water which are adapted to harden on contact with the air and thus cement any cracks in the cooling system through which they are carried by the water. Any one of these compounds which is free from solid matter may be employed as a temporary means of repairing a cracked cylinder jacket when it is not convenient to take the engine down for welding; in fact, in many instances this method of repair has been found so satisfactory as to preclude the necessity of a permanent repair.

With any tractor engine it will be necessary to remove the accumulation of carbon from the walls of the combustion chamber, the valve heads and the tops of the pistons once or twice during the season. The tendency to deposit carbon is a chronic ailment with which all internal combustion engines are afflicted to varying degrees, depending on operating conditions, fuel used, proportioning of the mixture, condition of the engine—especially as to piston and piston ring

fit,—character and grade of oil used for lubrication, etc.

When all is said and done, the best method of removing the carbon is to take the engine down far enough to get at the deposit, and then scrape it off with special carbon-scraping tools made up for this purpose and so shaped that the blunt knife edge can be worked into every nook and corner and the last trace of the troublesome carbon deposit removed.

With engines equipped with separable cylinder heads this is not a hard job at all, for by unbolt-

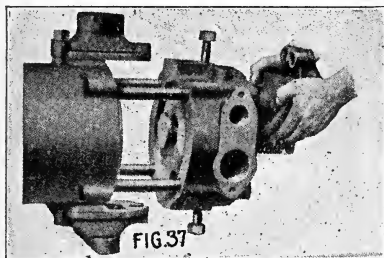

Fig. 37. Avery separable cylinder head.

nary paraphernalia, such as water manifolds, ignition cables, etc., and after draining the cooling system — the entire combustion chamber is exposed.

Under any circumstances it will be found that the employment of a steel wire brush, or a piece of steel wool, will considerably aid in removal of the deposit unless it be of the "tacky" kind; then hard scraping is the only resort. Where the cylinder heads are not separable, it is sometimes possible to employ flexible wire carbon scrapers, getting at all parts of the combustion chamber through the valve cap openings, and finally blowing the accumulation of carbon flakes out of the cylinder with an air blast. Of course, on an engine of this type, if an oxygen burning apparatus is available, a much

cleaner job can be effected by burning than by attempting to scrape through the valve cap holes, which at best is a makeshift method.

After thoroughly scraping the piston tops and combustion chamber walls, in the case of the separable head engine, before replacing the head casting, see that there is no carbon on the valve seats and make sure that the cylinder head gasket is in good condition. Replace the gasket in proper position; it is best to put it back without shellac. Replace the cylinder head casting and bolt it down in place, making sure to draw up gradually on the bolts all around the casting so as to distribute the strain evenly. Never tighten up to the limit on one bolt with the others all loose; take a few bites on each and work them in rotation until all are drawn up snugly.

With the engine all assembled, run it for a while to warm the jackets thoroughly, and then apply the wrench to the cylinder head bolts again and draw them up, taking up all the slack which has developed due to expansion under the heat.

Like the cylinders, the pistons are also made of cast-iron and are carefully turned down to a size which permits of a slight clearance between the piston and the cylinder wall. This clearance varies with different engines, but it can generally be accepted as one-thousandth of an inch for each inch of diameter of the piston, the clearance being measured on the skirt of the piston; the skirt is the lower section. As a rule, the clearance at the top of the piston will be somewhat larger than this, due to the fact that the top of the piston is subjected directly to the heat of the burning gases and becomes considerably hotter than the skirt, and as a result expands more.

The function of the clearance is quite obvious. The piston, not being water-cooled like the cylin-

der walls, will reach a higher temperature under operative conditions than the latter and will consequently increase in diameter at a more rapid rate than will the cylinder bore. The clearance is left so that the piston, even when heated up to maximum temperature, will always fit loosely enough in the bore to slide freely, with no tendency to bind or seize. Regardless of the tem-

perature attained, however, some clearance is always present between the piston and the cylinder wall.

That being the case, it is apparent that there will be a tendency for the gases to rush past the piston through this space on the compression and power strokes; also for the air in the crankcase to rush up into the combustion chamber on the intake stroke. In order to counteract this tendency

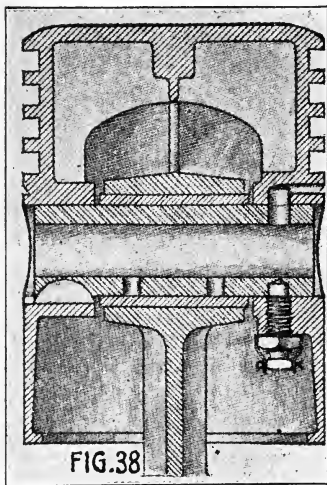

Fig. 38. Section of piston showing ring slots, bosses, webs, piston pin and connecting rod eye.

for the gases to rush past the piston, the pistons are slotted, as shown in Figure 38, and into these slots, which are of uniform depth all around the piston, are fitted expandable rings, called piston rings.

The piston rings are cast-iron rings, generally eccentric in form and slotted or split at the narrowest point. The rings are turned down to the

exact diameter of the cylinder bore on the outside before slotting. When slotted, therefore, they expand slightly and can be sprung into position in the slots on the piston. With most tractor engines, three rings are fitted, although in some cases four and even five are employed. Their peculiar shape and the character of the metal makes them springy and resilient, and the gradually increasing section from the split or slot to the largest section diametrically opposite it insures equal tension at all points on the periphery of the ring.

In position on the piston and with the piston in the cylinder, the rings expand outward against the cylinder wall, closing up the clearance space left between the piston and the cylinder wall, and thereby prevent the loss of the gases and the blow-by of air. The rings also take a good part of the wear, distribute the oil on the cylinder walls, and check the passage of oil past the piston and into the combustion chamber in excess; they tend to cushion the "cant" or "slap" of the piston at each end of its stroke due to reversal of motion and the angle of the connecting rod.

The lower ring is usually called the "wipe" ring, due to the fact that it scrapes off the excess oil from the cylinder wall and returns it to the crankcase chamber. Where the wipe ring is fitted below the piston pin, it usually is positioned quite low on the piston, so that it just overruns the counterbore at the lowest part of the cylinder bore—the counter bore is the tapered section of the bore so formed as to facilitate replacement of the pistons by compressing the rings and preventing them from catching or jamming. The reason for the wipe ring overrunning the counterbore is so that the oil it carries down will have ample passageway back to the crank-

case chamber and will not be returned to the upper part of the cylinder wall by the upward movement of the piston.

Where the wipe ring is positioned above the piston pin, and in a few instances where it is located well down on the skirt, this same function is performed in another manner. Immediately below the wipe ring is turned an oil relief groove, generally triangular in cross-section. The oil scraped off by the wipe ring collects in this relief groove and is returned to the crankcase chamber through a series of holes which carry it to the inside of the hollow piston.

The piston is provided with two bosses on the inside, into which is fitted a hollow steel pin called the piston pin or "wrist" pin, and which serves to connect the piston to the upper end of the connecting rod. The pin is made of comparatively soft steel, but very tough in nature, so that it is well adapted to stand up under the constant shock encountered under the explosions without becoming brittle and snapping, due to crystallization. But as the piston pin must also take a certain amount of heavy bearing wear, due to the oscillation of the rod with the engine in operation, it is obvious that its outer surface, must be well adapted to resist this wear. Consequently, the pin, after being rough shaped to size, is "case hardened"—that is, it is subjected to a heat treating process which leaves the outer shell very hard and wear-resisting to a depth of from two to five thousandths of an inch; then the pin is finished to exact size by grinding. This hard shell takes the bearing wear, while the tough core carries the brunt of the explosive pressure.

In some instances, the pin is clamped fast in the upper end of the "eye" of the connecting rod and allowed to find a bearing in the piston bosses;

in other cases, the pin is made fast in the bosses by pinning or by a set-screw or other means of locking and the bearing is in the eye of the rod. In the latter case the eye is always bushed with a bronze bushing which takes the wear. In the first case, however, as a rule the bosses are not bushed, since the cast-iron material of the boss provides a fine wearing surface. In a few instances, bronze bushes are fitted to the bosses.

Internally, most pistons are provided with webs radiating from the piston head, and the function of these webs is not so much to provide additional strength and support to the piston head, although they do stiffen up the bosses, as it is to assist in the radiation of the piston head heat to the air in the crankcase chamber and thereby maintain the piston at a moderate working temperature. In some cases, also, the piston skirts are provided with oil grooves—just shallow slots—which serve to hold a quantity of lubricant and distribute it evenly over the cylinder wall surface.

Care and Repair of Pistons.—The pistons, like the cylinders, are subject to wear. As was mentioned under the section dealing with cylinder repair, the usual practice is to replace them with new oversize pistons when they show wear to an excessive degree or when scored, or when either of these two ailments have affected the cylinder bore. This is necessary to secure a proper fit.

When the wear is not excessive, correction can be made by removing the piston pin and detaching the connecting rod and then heating each piston to a cherry red and allowing it to cool very slowly. The heat should be applied evenly and the temperature mentioned should not be exceeded; if the piston is cooled too quickly it will warp out of shape. If properly done, the effect will be to expand the pistons slightly, and

they will be enough larger than they were originally to permit of lapping down to a proper fit in the cylinders.

The lapping is accomplished in the same manner as described above, with the exception that in this case the piston is lapped right into the cylinder it is intended to use it in. The ground glass and oil mixture is used sparingly and lapping is continued until when dry and clean the piston moves easily throughout the length of its stroke without any tendency to stick or bind; nor will it bind when twisted around. After being perfectly fitted, it will be necessary to fit new rings to the piston.

The piston ring grooves are likely to be worn after long use. In such a case, it will be found that the pistons themselves are no doubt badly worn so that replacement is necessary. It never pays to attempt to true up a ring slot by turning it true to a larger size in the lathe. The best plan is to get a new piston and fit standard size rings to it in the manner outlined below.

Piston Rings.—The piston rings will wear both on their peripheries and on the upper and lower edges, so that they will become a “sloppy” fit in the ring grooves. This will not only permit of the escape of the compressed gases on the compression and power strokes, but will also permit the oil working past the rings—or rather in behind the rings and then up above them. As a matter of fact, this sloppy condition of the rings causes them actually to assist in elevating the oil, for on the downward stroke of the piston the rings work to the top of the grooves, leaving all the space represented by the original clearance left in fitting, and the subsequent wear, below the under side of the ring, the lower edge of which serves to scrape the oil from the cylinder walls

and carry it through this space to the pocket in behind the ring. When the piston starts on its up stroke, the ring shifts to the bottom of the slot, leaving the space at the top through which the oil is pumped by the ring movement and deposited on the cylinder walls above the ring to work up eventually into the combustion chamber, as indicated in Figure 39.

As a rule, when the engine is taken down, unless it has seen unusually severe service, wear with the cylinders and pistons will not be apparent, or at least so appreciable as to make repairs necessary. This, however, is not so in the case of the piston rings. They will show wear in two ways; the periphery which contacts with the cylinder wall may be streaked with black lines

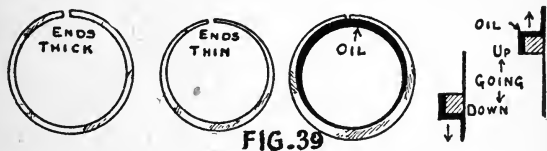

FIG.39

Types of piston rings showing how oil works upward.

Fig. 39. Showing oil pocket behind piston rings and how "sloppy" ring fit assists in oil pumping.

running in a vertical direction, showing that the fit is poor and that the ring has not been in contact with the cylinder wall all the way around, so that the gases have "blown by" the rings, leaving the black marks, or else the upper and lower sides of the ring may be worn so that the rings are a loose fit in the ring grooves on the piston. In the former case, unless the blow-by can be traced to the use of incorrect grade of oil which has not had sufficient body to maintain a perfect piston ring seal under the heat, thereby preventing the escape of the gases, replacement of the rings with the new ones will be necessary.

Sometimes, where it is found that even the fitting of new rings does not effect a cure, it is well to increase the pressure per unit of ring surface on the cylinder wall, and this is done by the very simple process of fitting rings with a groove, similar to an oil groove, all around the periphery which cuts down the surface in actual contact with the wall. As the total ring pressure, or tension, is the same and the surface over which it is distributed is smaller, it stands to reason that the unit pressure is increased and the ring will hold the gases to better advantage.

The cost of new piston rings is so low that when it is necessary to remove the rings from the ring slots for any reason whatsoever, it scarcely will be worth while to replace the old ones; it is much better to fit new rings all around. Such being the case, there is scant reason for wasting time endeavoring to remove the rings whole; they are very brittle and can be broken and readily removed.

If, however, it is desired to remove the rings without breaking them, provide short strips of

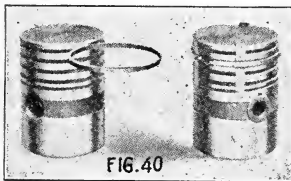

Fig. 40. Fitting and removing piston rings.

sheet brass or steel, about 22 or 24 gauge, one-half inch wide. With a screwdriver lift the end of the ring and slip one of these metal slips under it, as indicated in Figure 40, working it around to the back with the aid of the screwdriver. Do the same with one of the other slips, using the remaining slips to carry the ends of the ring. For the top ring, the use of the metal slips may be dispensed with

if you work gently and do not force the ring too hard with the screwdriver; but for the lower rings they are necessary in order to bridge the upper ring slots, so that the rings will not slip into them when they are being removed.

Be careful in removing the rings, to so mark them that they can be returned to the same ring grooves. After removal, if the ring slots in the piston are not worn, clean out the carbon deposit with a blunt screwdriver, or, better still, with a

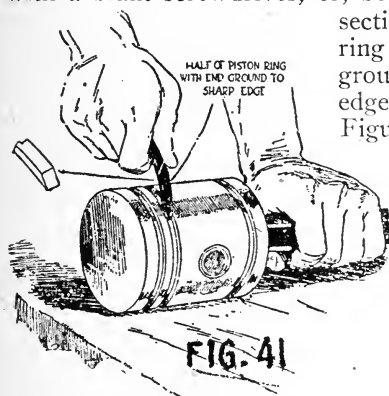

Fig. 41. Cleaning ring grooves with sharpened section of broken ring.

section of a broken ring which has been ground off to a chisel edge as indicated in Figure 41. Where

the rings are a sloppy fit in the grooves it is essential that they be replaced with new ones which should be properly fitted. A good way to gauge the fit is indicated

in Figure 40. Take the new ring and fit it into the slot as shown. If it is a proper fit, there will be just an appreciable play at the outer edge of the ring diametrically opposite the point of contact with the piston; if there is more than just an appreciable shake or movement, try another new ring to this slot which may prove a better fit. The ring should be rolled all the way around in the slot and the fit determined at several points. If it is found that the ring is too snug a fit, rig up a trimming board, as indi-

cated in Figure 42, covering down a perfectly true, smooth piece of board with very fine sandpaper. The ring can be rubbed down to a proper

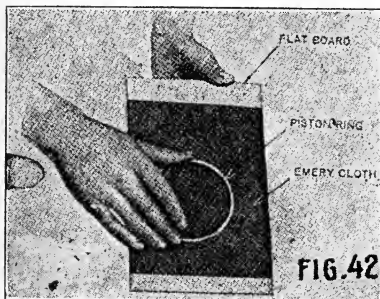

Fig. 42. Trimming board and method of using it to secure proper ring fit in groove.

fit on this, provided that the pressure is exerted evenly on all sides of the ring, so as not to cut more off one side than the other and so disturb the parallelism of the edges. After a ring has been fitted to a slot, mark it so that you will be sure and place it in the proper slot. When very close fitting is desired, filing on a special ring-holding board made up with a few brads to hold the ring compressed, as indicated in Figure 43, is efficacious.

New rings will be so large as to diameter, that when compressed, fully closing the gap, they either will not fit into the cylinder bore at all, or else when they do enter it they will not leave a proper joint clearance. The fit of the rings to the cylinder bore can be determined (Fig. 44) by putting a piston without rings and from which the piston pin and connecting rod have been detached into the cylinder bore and pushing it

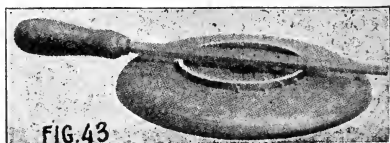

Fig 43. Filing board for close fitting of ring.

After a ring has been fitted to a slot, mark it so that you will be sure and place it in the proper slot. When very close fitting is desired, filing on a special ring-holding board made up with a few brads to hold the ring compressed, as indicated in Figure 43, is efficacious.

far enough into the cylinder to leave room beneath it for a piston ring. The ring should be sprung into this space, if possible, and the gap clearance measured with a feeler gauge.

The clearance should be just about $.005$ of an inch. If too small, hold the ring between blocks of soft wood in a vise, so as not to mar the edges, and file off enough of the metal on the ends of the rings to leave this clearance, using a very fine mill-cut file for this work. If a feeler gauge is not at hand, it is well to remember that the thickness of a piece of ordinary newspaper is $.003$ of an inch, so that if a double thickness is used to determine the clearance the result will be entirely satisfactory. Naturally, the rings should be fitted to the cylinders they are to work in; not all to the same cylinder.

Care must be taken not to break the rings in placing them back on the pistons. The bottom ring should be put on first, using the four little metal strips to bridge the upper ring slots and facilitate the manipulation of the ring. After the rings are placed on the piston, try them again to make sure that they work freely, as a tight ring may cause a scored cylinder; and even if that is escaped, it is bound to leak and forestall our purpose in placing it on the piston. Finally, slip

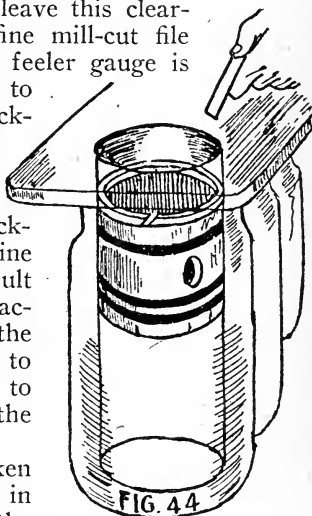

Fig. 44. Method of determining correct piston ring gap clearance.

the rings around so that the slots or joints do not fall in line; it is well, before replacing the pistons in the cylinders, to space the joints at an angle of 120 degrees with each other. This will tend to check leakage.

After new rings have been fitted, it will take a run of at least several hours for them to have worked into a perfect fit to the cylinder walls, and it is well to see to it that the engine has plenty of oil during this period. At the end of that time the compression of the engine should have improved considerably.

The connecting rod (Figure 45) in all modern tractors is a very substantial drop forging, made usually of vanadium steel or alloy steel of one sort or another, which is adapted to provide the

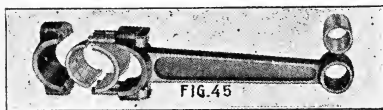

Fig. 45. Typical connecting rod disassembled.

greatest degree of toughness under the work encountered. It must be remembered that the connecting rod, like the

wrist pin, carries the full brunt of the explosion, and that, moreover, it is subjected to a whipping action and to pressure at an angle which taxes its strength to the utmost.

It is obviously necessary to provide the greatest degree of strength with the least possible weight, and in order to accomplish this purpose, not only has the engineer gone to the best of material, but he also has gone to the best possible sectional shape to provide rigidity—the I-beam. The rod as at present designed, is in reality an I-beam girder, tapering from top to bottom, and provided with a split bearing holder

at the lower end, the cap being bolted to the rod proper by either two or four special steel bolts. It has been usual in tractor practice to line the big end or crank pin bearing with babbitt metal, which is poured into the rod while



Fig. 46. Jig for babbitting connecting rod.

molten and with a mandrel of substantially the same diameter as the crankpin in place. A jig for pouring such a bearing is indicated in Fig. 46.

When the metal has cooled, the mandrel is removed, the rough parts of the casting smoothed out and the bearing split with a saw along the plane of the bearing cap face. Then the bearing surface is finished perfectly, first by reaming and afterward by blueing and scraping to a perfect finish.

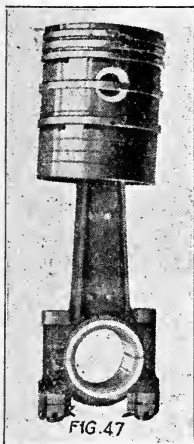

Fig. 47. Typical piston and connecting rod assembly for tractor.

Babbitt metal is used for the bearing surfaces in both main bearings and connecting rod bearings, first, because it stands up well under the friction and the constant pounding due to the explosions; and second, because it provides a measure of safety. If, for instance, the bearing should

become hot, due to lack of oil or some other cause, instead of expanding and seizing the bearing pin as a bronze bearing would do, and cutting the pin surface badly, and at the same time severely

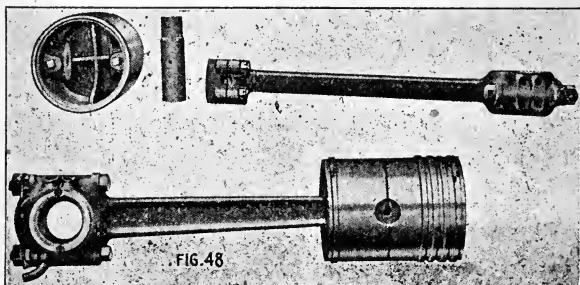

Fig. 48. Detail of piston, piston pin and connecting rod of Aultman-Taylor tractor.

straining the shaft, the babbitt bearing simply melts and runs out, leaving the bearing perfectly free. It immediately begins to give audible evidence in the shape of a heavy pound, that something is wrong, and the operator is warned of the necessity of shutting down the engine and making the necessary repairs. In the case of the bronze bearing under similar circumstances, the pin would be so badly damaged that even if the shaft were not sprung by the severe strain imposed by the seizure, regrinding of the pin to bring it back to a perfectly smooth bearing surface would be necessary; that, of course, entails removal of the crankshaft.

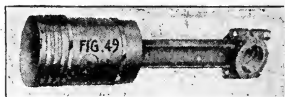

Fig. 49. Piston and connecting rod of Rumely tractor.

As might be expected the crankshaft as the member which carries the full load developed by each of the cylinders, is made of drop-forged steel of special analysis for toughness; generally chrome nickel steel, which resists crystallization well, or vanadium steel, which also presents a

measure of protection from this score, is employed. After being roughly forged, the shaft is trimmed down to approximate shape and the pins for both main and crankpin bearings either



Fig. 50. Three-bearing crankshaft for four-cylinder engine.

machined to a finish or, as in latter day practice, ground to a perfect surface. The

number of bearings used will, of course, depend entirely on the type of engine employed, the number of cylinders used, etc., as was made perfectly plain in the preceding chapter. The bearings themselves are practically the same as the crankpin bearings, being split with a bolted-on cap and lined with babbitt metal.

In realization that, after all, pouring a bearing is not a job to be undertaken by the layman—especially when it comes to fitting—many tractor engine manufacturers are giving up the poured babbitt bearing in favor of the shell type of bearing. Here we have a bronze shell of exactly proper diameter to fit the bearing holder; this bronze shell does not take the wear, but simply serves as a support for the babbitt wearing surface with which it in turn is lined and which

provides the actual bearing surface. The bronze shell is riveted, or screwed, solidly in place in the bearing holder,



Fig. 51. Two-bearing crankshaft on Avery four-cylinder opposed engine.

the rivet or screw heads being countersunk below the bearing surface so that there is no chance of their coming in contact with the pin surface.

With this type of bearing, replacement of the bearing is greatly facilitated, for it is simply necessary to remove and discard the worn shell and fasten the new one firmly in place. Since



Fig. 52. Counterbalanced crankshaft on two-cylinder vertical engine.

the shells are made on the limit system, the shells fit properly in place and fitting is reduced to a minimum. It will even be found that the actual fitting of the bearing by blueing and scraping after the shells have been put in place, is reduced to a minimum, and we not only get a better fitting bearing when all the work is done, but we also accomplish the work in a very short space of time.

At one end, the crankshaft is provided with a spur gear, which is sometimes formed integral with the shaft and in other cases is formed separate and keyed, pinned or otherwise firmly fastened in place. This gear meshes with a second gear twice its size, also fastened firmly to the camshaft, the two comprising the timing gear train; the relation is such that the camshaft revolves at half the crankshaft speed for the proper operation of the valves, as indicated in the first chapter.

The camshaft, like the crankshaft, is



Fig. 53. Rumely crank case construction showing main bearings.

drop-forged of alloy steel, and the cams are ground to exactly the proper contour, at the same time the bearing pins are trued up and ground to a proper finish. Generally, considering a four-cylinder vertical engine, the camshaft will be supported in three bearings, two of which will be of greater diameter than the maximum lift of the cams, so that the bearing, which is not split as with the mainshaft bearings, can be

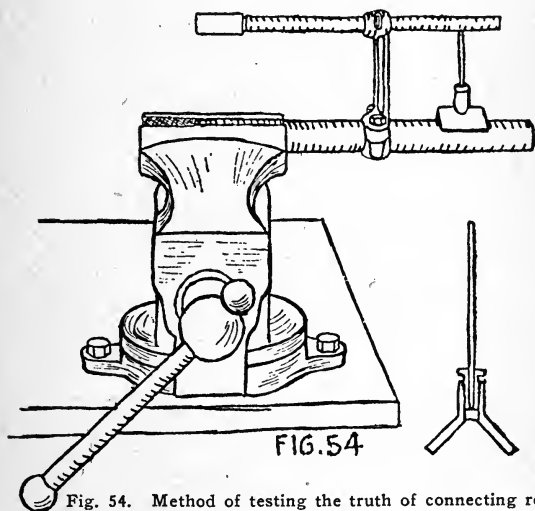

Fig. 54. Method of testing the truth of connecting rod.

slipped over the cams into place. With the third bearing at the front end, it is not necessary to provide such a large diameter, since the shell need not be slipped over the cams. These bearing shells are generally of bronze.

Repairs to Connecting Rods, Etc.—When making a general overhaul of the engine, it is well to check up on the alignment of the connecting rods, especially if the engine has been productive

of an elusive knock. The rod may be sprung so that the piston is crowded at an angle with the cylinder bore, or it may be twisted so that the piston pin does not lie in the same plane as the crankpin. The proper method of testing the rod for these defects is indicated in Figure 54. A mandrel of the same size as the crankpin is supported in a vise and the rod is clamped tightly to this by means of the crankpin bearing. A second mandrel of a diameter the same as the piston pin is clamped in place in the eye at the upper end of the connecting rod. These mandrels should be sufficiently long for their parallelism to be tested. The illustration shows an easily made and convenient gauge for testing their parallelism. By sighting along the mandrels it is easy to determine whether there is a twist in the rod, so that the mandrels do not lie in the same plane. If either test shows the rod to be out of truth, it can readily be sprung back by bending cold, simply by applying pressure in the proper direction on the mandrel through the connecting rod eye.

Piston Pin.

—The piston pin itself will give evidence of wear after long use and looseness in the bushings provided for it in the piston bosses will give rise to a sharp metallic click or knock. In

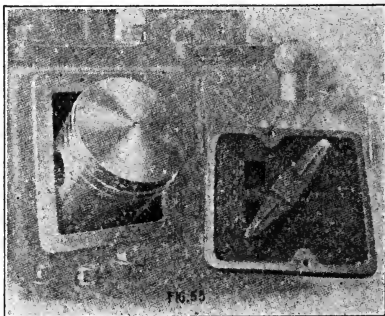

Fig. 55. Removing piston and rod assembly through inspection opening on Best engine.

such a case, it will be necessary to replace the piston pin with a new one, and in some cases to rebush the cylinder bosses. Try the new pin in the bosses, and if it is a good, snug fit with no play, rebushing will not be required. If, however, it is loose, the old bushings can either be reamed out to take an oversize pin which is a comparative simple operation, or they can be drifted out with a drift slightly smaller in diameter than the outside measurement of the bushing, care being taken to hold the piston firmly on a soft wood saddle while the bushing is being

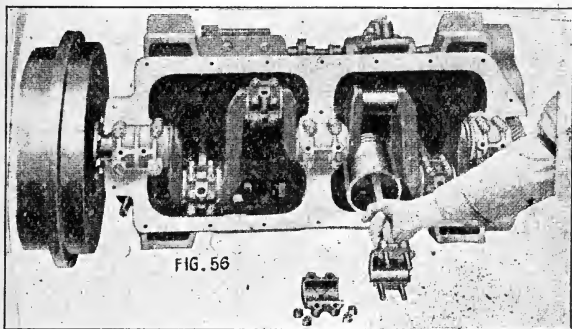

Fig. 56. Lower crank case removed, showing main bearings, connecting rod and bearing, and the ease with which piston is removed in Waukesha engine.

driven out. The new bushings can be pressed into place by means of a press or a vise, care being taken to pad the jaws of the press with a soft wood block so as to mar neither the piston nor the bushing. It will be necessary to ream the new bushings to take the new piston pin, even though it is not oversize. Extreme care should be taken to clamp the pin firmly in the eye of the connecting rod so as to guard against its working loose and scoring the cylinder walls.

Where the pin is locked in the bosses and bears in the rod eye, only one bushing at this point is necessary.

Mainshaft and Crankpin Bearings.—Both the mainshaft and crankpin bearings are adjustable. Evidence of looseness comes in the form of a heavy pound or knock, which should be heeded and the engine stopped immediately. In case a crankpin bearing is suspected of being at fault, drain the oil from the engine and remove the plate from the bottom of the crankcase, which

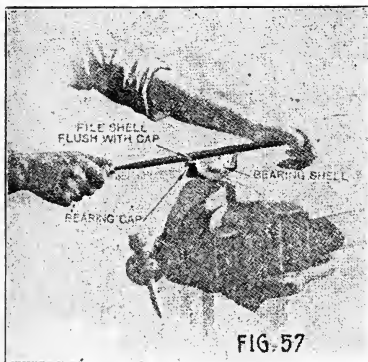

Fig. 57. Method of adjusting bearing by filing off cap slightly.

will expose the connecting rods in the case of a vertical cylinder engine (Figure 56). Sometimes the rods can be reached through inspection plates in the crankcase. Taking a firm hold on the crankpin bearing each rod can be tested in turn for looseness. In case appreciable play is detected, take off the crankpin bearing cap, hold it in a vise and draw file the ends (Fig. 57), taking very little metal off and making sure to take it off evenly all around and just as much from one side as from the other.

Where the bearing is "shimmed" for adjustment (Figure 58), removal of a thin shim on either side will generally suffice, no filing being necessary.

will expose the connecting rods in the case of a vertical cylinder engine (Figure 56). Sometimes the rods can be reached through inspection plates in the crankcase. Taking a firm hold on the crankpin bearing each rod can be

Replace the cap, being sure that the punch marks correspond, and tighten up the crankpin bearing bolts until the bearings fit the pin snugly. Test the tightness of the bearing by turning

the engine over with the starting handle.

In the ordinary course of events, provided the engine has received decent treatment and

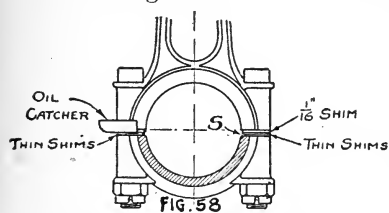

FIG. 58. Shimmed bearing.

care, especially as to correct lubrication, it will be necessary to take up on all the crankpin bearings slightly once every couple of months. Proceed as above, being careful not to get the bearings too tight, as in that case they will cut out rapidly. After adjusting the bearings, it is well to idle the engine for a couple of hours before taking the tractor into the field to run the bearings in to a good fit. Do not forget to lock the crankpin bearing bolt nuts when the bearings have been properly fitted and set up.

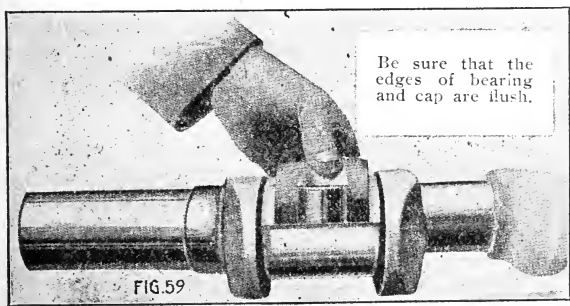

Fig. 59. Rough spotting to determine where bearing surface is high.

In case the wear is too great to be taken up by the above method, or in case of bearing failure, the rod will have to be rebabbitted. To do a worth while job of repouring a bearing requires not only proper equipment in the way of a jig, but also experience in bearing pouring. The best advice that can be given in a case of this sort, is to send the rod or rods off to the nearest service station or the nearest competent repairman, who will rebabbitt the bearing at small cost.

With the rod relined with new babbitt, it is

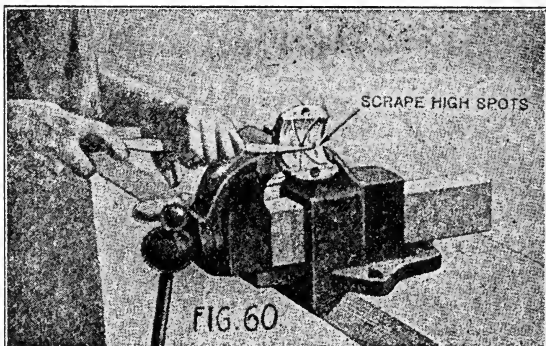

Fig. 60. Illustrating correct method of scraping a bearing after "spotting" to determine the high spots.

not a difficult job for the man with patience and a limited amount of mechanical skill to spot and scrape in the bearing to a good fit on the crankpin. Coat the surface of the crankpin with a very thin film of Prussian blue; the thinner the better, and it should be spread perfectly even. After thoroughly coating the pin, mount the bearing on it, clamping it firmly, but not so tightly in place that it cannot be turned; be sure and apply it to the pin in the same position as

it will be used in the engine when reassembled (Fig. 59). Then turn the bearing around a couple of times, undo the bolts and remove it. It will be found that all the high spots on the bearing surface will show up in blue both on the upper half and the lower half. Now hold the bearing in the vise, as shown in Fig. 60, and with a good, sharp bearing scraper scrape a small amount of metal off these high spots, and in fact from the area just around them. When both top and cap have been scraped, reclamp bearing on the pin after spreading out the blue again, and take another impression. If the scraping has been carefully done, the blue this time will cover a much larger surface.

Scrape down the high spots again, being more careful to take only a small amount of metal off. Use the flat of the scraper blade and give it a twisting diagonal stroke in order to avoid ridging the comparatively soft bearing metal. After several repetitions of this process, the blued area will be found to very nearly cover the bearing surface, provided the scraping has been discreetly done. Then wipe bearing and pin clean, smear it well with lubricating oil and adjust it to a snug fit as indicated above. If it is found, when it comes time to set up the bearing, that when the bolts are screwed up tight the bearing grips the pin too tightly, cut several shims of very thin brass—.002 to .004 of an inch—and place an equal number of these on each side of the bearing between the two halves to provide a correct adjustment when the bearing bolt screws are pulled up tight.

In every case when it is found necessary to reline a bearing, the pin should be carefully examined for roughness or ridges; it is well also to test it for roundness with a micrometer

or a good pair of calipers if these instruments are at hand. If the pin is at all rough, do not attempt to fit a new bearing on it until it has been smoothed up and put in good condition again. If this precaution is not observed, all the trouble and expense of putting in the new bearing will come to naught, for it will quickly be cut out again, making a repetition of the task necessary. An experienced machinist can take a pin that is not too badly scored and file it to approximate condition, finishing it off by lapping with a clamp and very fine abrasive. The best plan, however, is to send the crankshaft that is found to be scored as to the bearing pins to the service station and have it reground and put in first-class shape again.

In connection with the above, one of the leading tractor manufacturers says:

"Fitting connecting rod bearings is very important, and you should know that the rods fit properly at all times. Do not allow them to run loose and 'pound.' It is important to keep connecting rods tight and well-oiled at all times. Bearings are constructed so that shims can be removed to take up the wear. When bearings are worn so badly that all shims have been removed it is then necessary to use new bearings.

"The one-half bearing grooved for oil must be fitted in lower one-half of connecting rod shell.

"The first operation is to fit the shells tight in the connecting rod and the connecting rod cap so they will have a full bearing back of the shell. About the best way to get a good fit is to place the shell on the crankshaft and then tap the cap to place, as shown in Fig. 61.

"The next operation is to get a good bearing fit to the crank. To do this, it is best to use lamp black to 'paint' the pin or crankshaft, then

set half of bearing on pin and work back and forth; the lamp black will show the high places or where bearing needs to be scraped. Keep this operation up until the bearings show a nice even fit all over the surface before you put the rods on the crankshaft to stay.

"The connecting rod bolts should be drawn up tight, when the bearings are properly fitted and bolts drawn up as tightly as possible, the connecting rod bearings should almost sustain the weight

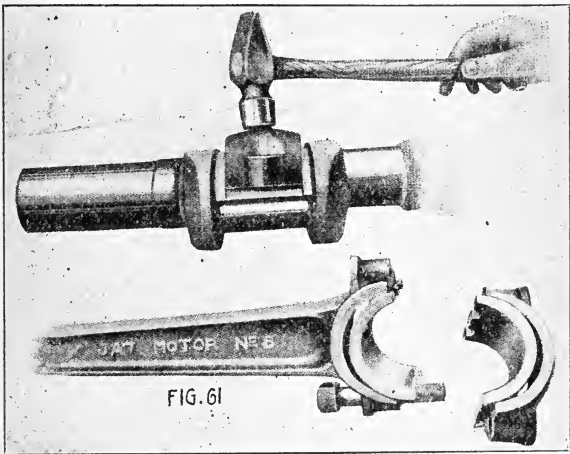

Fig. 61. Fitting bearing shell to rod bearing.

of the rod. If the cylinder is off and the rod raised to the top it should just 'ease' down of its own weight. If it drops easily and loosely it has not been fitted close enough. If the cylinder is not off, test it by turning fly-wheel.

"If the rod will not fall of its own weight, not enough shims have been used. *Do not* back the nut off until the rod will drop, but put in more

shims. The bolts should be *tight*, and edges of bearings should be in close contact with shims. It pays to fit the bearings properly.

“Every morning take off inspection plate and examine the bearings and oil level, and see that the connecting rod bolts are tight. Remember the old adage, ‘A stitch in time saves nine.’ It is mighty true with a motor. A little neglect may cause an expensive break.”

To take up on the mainshaft bearings, take off the three babbitted caps from the mainshaft bearings and clean the bearing surface with gasoline.

Apply Prussian blue or red lead to the crankshaft bearing surfaces, which will enable you, in fitting the caps, to determine whether a perfect bearing surface is obtained.

Place the rear cap in position and tighten it up as much as possible without stripping the bolt threads. When the bearing has been properly fitted, the crankshaft will permit moving with one hand. If the crankshaft cannot be turned with one hand, the contact between the bearing surfaces is evidently too close, and the cap requires shimming up, one or two brass liners usually being sufficient. In case the crankshaft moves too easily with one hand, the shims should be removed and the steel surface of the cap filed off, permitting it to set closer.

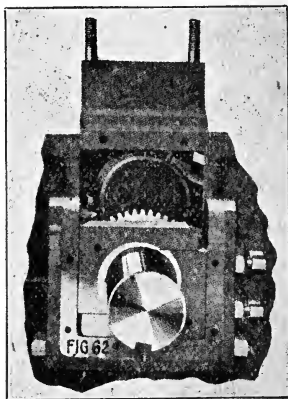

Fig. 62. Showing simple means of adjusting Avery mainshaft bearings.

After removing the cap, observe whether the blue or red "spottings" indicate a full bearing the length of the cap. If "spottings" do not show a true bearing, the babbitt should be scraped and the cap refitted until the proper results are obtained.

Lay the rear cap aside and proceed to adjust the center bearing in the same manner. Repeat the operation with the front bearing, with the other two bearings laid aside.

When the proper adjustment of each bearing has been obtained, clean the babbitt surface carefully and place a little lubricating oil on the bearings, also on the crankshaft; then draw the caps up as closely as possible—the necessary shims, of course, being in place. Do not be afraid of getting the cap bolts too tight, as the shim under the cap and the oil between the bearing surfaces will prevent the metal being drawn into too close contact. If oil is not put on the bearing surfaces, the babbitt is apt to cut out when the motor is started up before the oil in the crankcase can get into the bearing.

It must be remembered that after scraping, the bearings will not be a snug fit on the pins, but will touch only at the high spots; if the scraping has been carefully done these high spots will be very numerous, spread all over the bearing surfaces, and naturally be comparatively small. After the bearing has been run in for a couple of hours, provided it is given plenty of oil, it should wear down to a perfect fit on the pin, which should eliminate any tendency for it to bind.

After long use, especially if the crankcase oil has not been changed at frequent intervals, the bearing surface will contain embedded gritty matter which will act as an abrasive and lap the bearing pin somewhat. In order to correct this

condition, it will be necessary to scrape the surface of the bearings, spot them in and refit them to proper alignment.

Crankshaft.—Aside from truing up the bearing pins as outlined under the last heading, the only repair that is ever called for by the crankshaft is to test it out for true running between centers or on knife edges. If it is found to be sprung, unless the spring is comparatively slight it should be discarded and replaced with a new shaft. A slight spring can be taken out, but as special jigs are necessary, the shaft should be returned to the factory or to the nearest service station for this treatment.

Camshaft.—Repairs to the camshaft are infrequent, since it is not subjected to hard wear. After several seasons' use, sufficient looseness may be detected in the camshaft bearings to make rebushing desirable; this is a simple matter of drifting out the old bushings and pressing in new ones, much as the piston pin bushings in the piston bosses were refitted. It sometimes happens also that the camshaft becomes sprung, generally as a result of being hit with a broken connecting rod or some similar mishap. If not too badly sprung, this fault can be corrected by blocking the shaft between two wooden blocks and applying pressure with a lever or jack at the high point to bring it back to shape; if badly sprung, and especially if the cams show appreciable wear, it is a better plan to replace the camshaft with a new one.

Tools and Their Use.—To properly care for a piece of machinery, certain tools are necessary in order to do the job quickly and correctly.

One of the chief causes of serious tractor troubles is that the adjusting or repairing is not

done when it should be done, and very often on account of the lack of proper tools or not knowing what tools to have on hand.

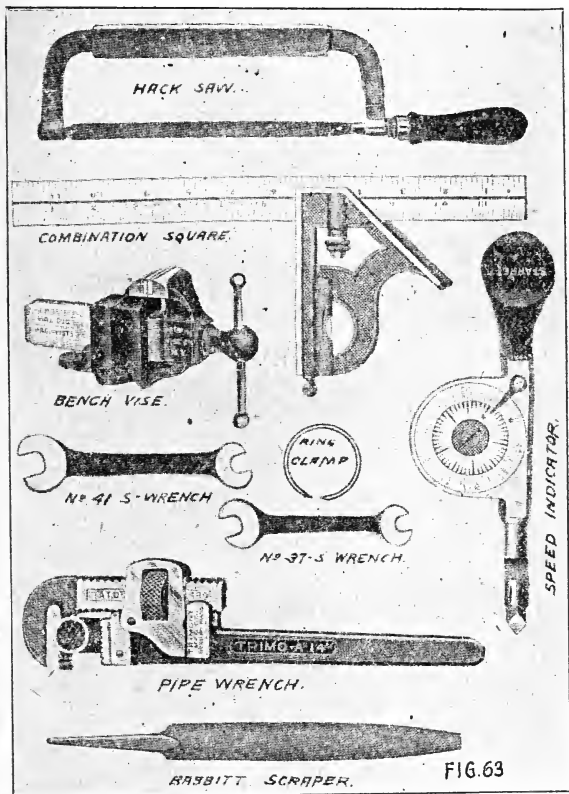

Fig. 63. Useful tools for tractor operators.

The following list of tools will be found about all that are necessary for doing all kinds of adjusting and repairing on your tractor, and from

time to time one will get other handy and useful tools:

- One 1½-pound ball pene hammer.
- One screwdriver, 10-inch.
- Two ¾-inch flat cold chisels, and
- One-fourth round nose chisel.
- Two oil groove chisels.
- No. 41 S wrench (semi-finish).
- No. 37 S wrench (semi-finish).
- 8-inch crescent wrench.
- 12-inch monkey wrench.
- 18-inch pipe wrench.
- Two round punches, ⅛-inch and ¼-inch.
- Hack saw frame and 10-inch blades.
- Pair tinner's snips.
- Carpenters' bit brace.
- Flat files, such as 10 and 14-inch.
- Half-round file (14-inch).
- Round file (½-inch).
- Combination square with 18-inch blade.
- Pair of good pliers.
- A carpenters' pinch-bar.
- One 10-inch and 14-inch babbitt scraper.
- Two pieces of ½-inch square hemp packing,
18 inches long.
- Two spring clamp rings.
- Carborundum stone.
- Soldering iron and solder.
- A whisk broom.
- A good bench vise.

The oil groove chisels are for cutting oil grooves in bearings, and you should own two of them, one with about ⅛" cutting edge and 3-16" on the other, so that grooves can be cut proper size in both large and small bearings.

The No. 41 S wrench fits standard size nuts of ⅞" and 1", and the No. 37 fits ⅝" and

$\frac{3}{4}$ " nuts, these four sizes being standard, and you will find most of the bolts and nuts on your tractor about that size. The 8" crescent wrench will take all sizes from $\frac{5}{8}$ " down as well as cap screws. The 18" pipe wrench is about right, since it will take all sizes of pipe used on your tractor.

The hack saw is a very handy tool when doing all kinds of repair work where a saw can be used.

A pair of tinner's snips are necessary when making new shims for bearings, etc.

Flat files can be purchased in all sizes to suit the needs. A half-round and a round file will be found very useful when enlarging bolt holes, etc., about implements.

The combination square with 18-inch blade will be found very handy when lining and squaring up bearings for babbitting, etc.

A short carpenter's pinch-bar will be used very much around the farm and on the outfit.

When babbitting bearings the most important tools for such work are your babbitt scrapers. A set of good scrapers can be made out of a 10-inch and a 14-inch half-round file by grinding off all the teeth on an emery wheel and then finish up smooth on a grindstone. Be careful when grinding on emery wheel so as not to draw the temper out of edge of file by allowing to get too hot. Continually dip file in water to keep it cool while grinding. The flat side should be ground out hollow, since in such shape it will sharpen easily and quickly.

The carborundum stone is for the purpose of keeping the edges of your scraper sharp so it will cut babbitt. You will find that a sharp scraper will cut babbitt and also brass very easily.

When dull it is almost impossible to touch it by scraping. You should make a case for your scraper out of paper, cloth or wood, so as to protect its edge when not in use.

The two pieces of half-inch square hemp packing are used to make a tight joint around shafts or hubs of gear when babbitting, and the spring clamp rings are used to hold the hemp up tight in place.

A soldering iron and some solder are very useful when mending oil cans, pipes, and such parts as can be repaired by soldering. The flux used when soldering is commercial muriatic acid with as much zinc put into it as it will dissolve, and have all surface to be soldered clean and bright.

A whisk broom is one of the handiest articles with which to keep a tractor clean. It will be found that if the operator will from time to time brush off all the dirt and trash which settles on a tractor he will be able to keep it clean with a very small amount of time spent with the whisk broom. For the purpose of wiping up grease and oil, old gaudy sacks cut up, or cotton waste should be used.

A bench vise attached to the rear platform of tractor will be found handy all the time and should be one of the tools first purchased.

The equipment for handling lubricants for tractor use are as follows:

The can in which hard oil is carried on the tractor for all hard oil compression cups should not be larger than five or ten-pound capacity, and should have a tight cover, one which will keep out all grit and dirt.

When taking out grease to fill a grease cup, use a short paddle which can be carried in the

grease can and remove the grease from on top of grease in can. Do not dig a hole in the center of the grease and continue it to the bottom of pail or can. By digging out the middle and having such a cavity in grease, helps to collect grit and trash which may fall into can unnoticed and thus get mixed with the grease, and thus goes into a bearing, where it does a great amount of harm, even more than the operator believes possible. Keep grease clean.

The can in which you carry gas engine cylinder oil should be about two or three gallon capacity. A five-gallon can is too clumsy and hard to handle. In a short time more oil will be spilled than the cost of two or three smaller cans. Keep the can closed up tight with a screw top or corked with a cork of solid material such as wood or lead. Never use a corn cob, as it breaks up easily and drops into the oil can; from there it gets into the lubricator and stops it up, thus again causing considerable delay and possibly damage.

Keep your oiling equipment clean. A small funnel with a medium fine screen should be used when drawing oil from the barrel into the can, so as to catch all chips from the bearings which get into a barrel when tapping for faucet, and also can be used when filling lubricator on tractor. Keep the funnel clean so no dirt gets into oil by first lodging on funnel.

The oil which is taken out of the splash basin of your motor from time to time can be filtered through a filter. Take a fifteen or twenty-gallon can or barrel and cut several small holes in its bottom and fill about half full of cotton waste or gunny sacks. The oil is poured into top of can and passes slowly through filter and is caught in another receiver below filter. This oil can

be used for gear oil or on other machinery. Never use it in motor again.

Whenever a man visits a tractor, and he looks inside of the tool-box and sees a heap of scrap iron, broken bolts, nuts, earth and tools mixed together, and then glances at the oil-handling equipment and sees an oil can wide open covered with dirt, and grease can without a cover and jammed into all kinds of shapes, he will not need to look over the tractor to tell just what kind of shape it is in. An operator can be judged by the appearance of the oiling equipment and tool-box.

CHAPTER IV.

Valves and Valve Mechanism.

How They Differ and the Advantages of Each Type—Proper Care and Adjustment.

TAKEN all in all, there is no system of the several which go to make the complete tractor engine that is of more importance to the correct functioning of the motor than the valve system. As a matter of cold fact, it is doubtful if there is any other feature of engine design that has been given as much careful consideration and experimental work as has the design and the arrangement of the various parts which have to do with the functioning of the valves.

We have alluded, in chapters ahead, to various valve arrangements; particularly the L-head and the valve-in-head types. In all, there are five distinct valve arrangements commonly employed in internal combustion engine work, as follows: T-head, in which the cylinder is provided with two cylinder pockets so that in cross section it resembles a Capital T, one valve being located in each of these pockets. Such a construction gives a very accessible engine; however, it entails the use of two camshafts, while at the same time the presence of cylinder pockets to any greater degree than is absolutely necessary is by no means desirable. This is due to the fact that the pocket provides additional surface for the radiation and loss of the heat of the explosion, which, as we learned in the first chapter, is the real source of our power, and the efficiency of the engine is impaired as a consequence. Also

the presence of a pocket, or two pockets, considerably retards the speed with which full combustion of the fuel charge can be effected, and by so doing we have a second cause of power loss.

The second type is the L-head type, with both valves positioned in a single cylinder pocket and operated from a single camshaft. This arrangement has the virtue of compactness and extreme simplicity, as to valve operating mechanism, and for these reasons it is typical of present-day tractor engine practice. The single pocket is not a great drawback and many manufacturers consider the accessibility and the simplicity which it gives rise to of greater importance than the slight power increase which can be attained by eliminating the pocket altogether.

The third system, and the one which at the present time is making the greatest progress in the tractor industry, is the valve-in-head type, in which both the valves are located in the cylinder head and operated by means of long push rods and tilting levers or rocker arms from a single camshaft. The virtue of this system is that it provides a combustion chamber which is a very close approach to the ideal spherical shape; there are no pockets in the cylinder and the combustion chamber presents less wall area for heat radiation in proportion to capacity than with any other type; at the same time, the location of the spark plug is such that we obtain the fastest possible speed of the flame—rapid flame propagation, as we term it—with no pocket of dead or partially dead gas to retard it.

It has the disadvantage of introducing some complication into the valve operating mechanism; more parts to wear and need adjustment. But in the modern valve-in-head engine, these

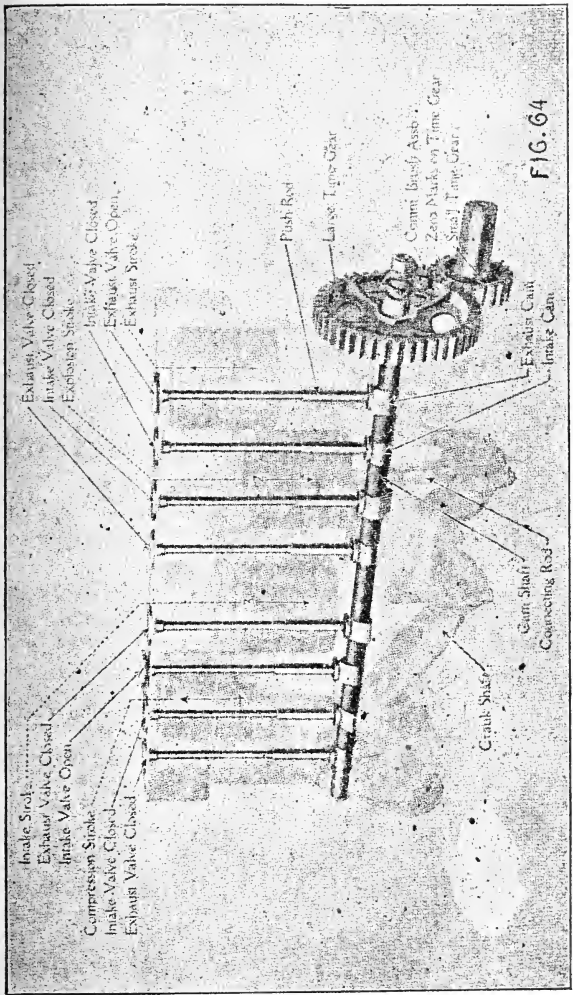

Fig. 64. Showing assembly of cylinders, crankshaft, pistons with camshaft and valve mechanism on a four-cylinder engine.

little points have been so well worked out that no trouble on the score of wear and lack of adjustment are chargeable against the valve-in-head engine, provided it is given at least as good treatment as any of the other types.

The two other types are by no means a factor in the tractor industry and we will dismiss them with a word. They are the F-head system with a single valve—the inlet—located in the cylinder head, and the exhaust valve located in the single cylinder pocket; and the Knight sleeve valve type, in which the functions of the valves are performed by two sliding sleeves surrounding the piston. In the F-head type, we can obtain very large valve areas with a very small cylinder pocket, much larger than can be obtained with the L-head type, and also much larger than can be obtained with the valve-in-head type. An engine with this valve arrangement, therefore, is particularly powerful despite the presence of the small valve pocket; however, the complication of the valve mechanism has stood in the way of the development of the type for tractor service, although in automobile application it is making marked progress. The Knight engine is not used for tractor service.

In Figure 64 the assembly of the cylinders, pistons, crankshaft, etc., with the camshaft and the valve mechanism on a typical four-cylinder engine of the vertical L-head type indicates clearly the relation of the various parts and the functioning of each. The valve proper, which is pictured in Figure 65, is made of tungsten steel in most modern motors, although quite a few manufacturers employ a cast-iron head with a steel stem welded in place. The cast-iron stands the heat well, which is of great importance, especially in the case of the exhaust valve, which

is constantly subjected to the intense heat of the exhaust gases; tungsten steel has been found even more efficacious from the heat-resisting standpoint, while at the same time the all-steel valve is not particularly subject to warping.

The valve head is shaped like a manhole and has a beveled edge which seats on a similarly shaped seat formed in the cylinder, so that when the valve is closed no leakage can occur around the seat and through the port, provided the valve is in good condition. The valve is ground to a gas-tight fit with the cylinder seat when the en-

gine is assembled at the factory.

The valve is positioned, with relation to the port which it controls, by means of a valve stem guide in which the stem of the

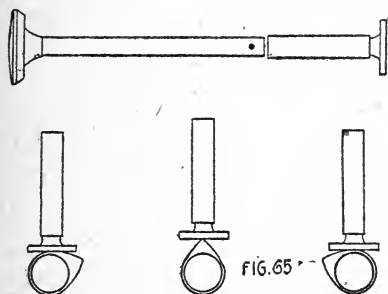

Fig. 65. Showing the valve and cam follower assembly and how the cam follower is actuated by the cam.

valve finds a bearing. This guide is usually formed of cast-iron similar to the cylinder, and in fact in some instances, is formed integral with the cylinder casting. The usual practice, however, is to make the guide separate and press it into place, so that when wear occurs the ill results occasioned by it can be remedied by removing the worn guide and fitting a new one.

It will be seen that the cam does not act directly against the bottom of the valve stem; a mushroom-shaped cam follower, push rod or tappet, as it is variously called, is interposed

between the cam and the valve stem and it finds its bearing in a tappet guide formed in the shelf on the upper half of the crankcase. These cam followers are also case hardened to prevent rapid wear.

The shape of the valve tappet is not always the same. In some engines the tappet is fitted with a roller which bears on the cam to reduce wear and noise.

The valve stem is surrounded by a valve spring, helical in shape, which bears against the under side of the valve pocket in the cylinder, being centered by the valve stem guide, and which is held on the stem by means of a washer and a short key or pin passing through a hole in the lower end of the valve stem. Other locking arrangements, such as horseshoe washers, fitting into recesses on the valve stems, are sometimes used.

This spring is sufficiently strong to return the valve rapidly to its seat when the cam follower rides off the hill on the cam. It is also sufficiently strong to prevent the exhaust valve opening under the suction or reduced atmospheric pressure in the cylinder on the inlet stroke.

Due to the arrangement of the crank throws on the crankshaft, it is not possible to fire the cylinders in exact rotation starting with number one—which is always the cylinder at the timing gear end of the engine—and working back in numerical order. On the four-cylinder engine shown in Figure 64 the firing order is 1, 2, 4, 3. Just what is happening in each of the cylinders when any particular one is firing is made plain by reading across in the following tabulation. Reading down shows the order of the strokes in any one cylinder :

Cylinder No. 1	No. 2	No. 4	No. 3
Power	Compression	Intake	Exhaust
Exhaust	Power	Compression	Intake
Intake	Exhaust	Power	Compression
Compression	Intake	Exhaust	Power

In other words, when cylinder No. 1 is firing, No. 2 is on the compression stroke getting ready to fire next. No. 4 is on the intake stroke and No. 3, having just fired, is exhausting.

In Figure 64 cylinder No. 2 is shown on the power stroke and naturally both valves will be closed. Reference to the tabulation will show that No. 1 should be on the exhaust stroke and it will be evident that the exhaust valve on No. 1 cylinder is raised in the figure. No. 3 should be on the intake stroke; the lifted inlet valve in the illustration proves the correctness, while No. 4 should be on the compression stroke with both valves closed; it is found to be so.

There is one other possible firing order on a four-cylinder engine with this type of crankshaft, and, in fact, it is the more commonly met with. It is 1, 3, 4, 2.

In the preceding chapter it was pointed out that the time of opening and closing of the valves was of great importance. While in seeking to obtain an insight into the principles of the engine it is well to consider that the valves open and shut exactly on the top and bottom dead centers, as the case may be, and remain open exactly one piston stroke up or down or 180 degrees of crankshaft movement; as a matter of fact in the practical engine such is not the case by a large margin.

As a rule, the inlet valve does open, or begin to open, when the piston is very near the top dead center just starting down on its intake stroke.

The downward travel of the piston is completed in a very short space of time—a fraction of a second—when the engine is turning over at its rated speed and in order for the new charge of gas to enter the cylinder through the inlet piping in sufficient quantity to fill the cylinder, its velocity through the constricted passages must be high.

It is true that all bodies in motion acquire momentum—that is, a tendency to persist in motion. The momentum is measured by the velocity at which the body is traveling multiplied by the weight of the body. It follows that a cannon ball weighing only a pound but traveling at very high speed can have a momentum numerically as great as a locomotive weighing thousands of pounds more than the cannon ball but traveling at a greatly reduced pace.

And so it is with our column of incoming mixture; its weight is only a little bit, but its speed is very high, so that the momentum it has acquired during the intake stroke is appreciable. We find it worth while to take advantage of this momentum by holding the inlet valve open for a brief interval after the piston has passed bottom dead center, the momentum of the rapidly moving gas column carrying more fuel into the cylinder and giving us a fuller charge.

Just how much “lag” is given the closing of the inlet valve with relation to the bottom dead center depends upon the size and the speed of the engine, the size of the valves and the design of the inlet port and gas passages. It varies considerably in different engines.

In a comparatively few instances this same principle is applied in the case of the exhaust valve; it is held open for a brief interval after top dead center is passed so that the momentum

of the gases passing through the exhaust piping will aid in clearing the cylinder and will tend to create a partial vacuum behind it which helps to pull in the fresh gas charge when the inlet valve is opened. Sometimes the inlet valve actually begins to open before the exhaust valve is fully closed, but this is rarely encountered in anything except very high speed racing engines, since it tends to make the engine hard starting and interferes with smooth operation when throttled down for low speed and idling. As a rule, as was said before, the exhaust valve is designed to close on top dead center and the inlet valve to open just at that point or a shade afterward.

But it is of very great value to thoroughly clear the cylinder of all the burned gases after the power stroke. And it is true also that as the piston starts down on the power stroke the effective pressure of the gases drops off very rapidly, so that when the crank is nearing the bottom dead center the pressure is not really worth while taking advantage of. It is found much better, in the way of smooth operation and economy, to open the exhaust valve while the piston has considerable distance still to travel on the power stroke so as to give ample time for the spent gases to escape; this also tends to make for cooler running, since the lower section of the cylinder is not exposed to such intensely hot gases. The "lead" which the exhaust valve opening is given on the bottom dead center varies greatly in engines of different design just as the "lag" given the inlet valve opening varies.

The timing of the valves is a matter with which the tractor owner or operator has practically nothing to do. The timing determined on by the factory engineer is brought about by the

design of the cams themselves, the mounting of the cams with respect to each other on the camshaft and the mesh of the timing gear wheels. This latter point is important to the owner, since if the engine is taken apart and the timing gear mesh disturbed, it is important that in putting the engine together again they be properly meshed or else none of the valves on the engine will be timed to open or close at the proper time with relation to the piston travel.

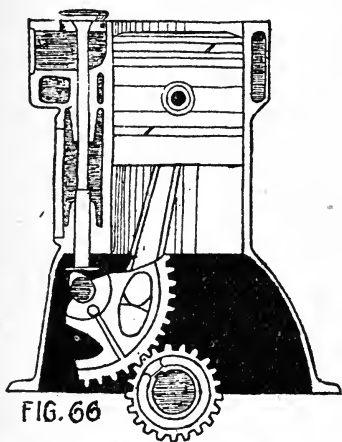

Fig. 66. Method of meshing timing gears to time engine correctly.

a punch mark. The proper mesh of the gears is accomplished when the punch-marked tooth is caused to mesh with the punch-marked hollow on the camshaft gear. Once this relation is established, all the valves on all the cylinders will be perfectly timed, for it will be remembered that all the cams are forged integral with the camshaft.

It is well, in taking the engine apart, to make

The exact setting of these timing gears is indicated both in Figure 64 and in Figure 66. It will be found that on the larger camshaft wheel there is a punch mark on the wheel rim adjacent one of the hollows into which the teeth of the pinion fit. On the crankshaft pinion one tooth will be similarly marked with

sure that the timing gears are punched. If not, punch-mark them as outlined above before unmeshing them so that they can be put back in proper mesh. This applies to other gears as well.

A point that should be borne in mind is that there is always a clearance left between the lower end of the valve stem and the upper surface of the push rod or tappet; this point is made clear by referring to Figure 65. The reason for this clearance is that the valve stem is going to expand under the heat and if it were in actual contact with the tappet, due to this expansion, the head would be raised slightly from the cylinder seat and this would result in leakage. It is highly important that there be a clearance at this point and also important that the clearance be maintained within certain definite limits. If it is too small, the expansion, especially in the case of the exhaust valves, which get tolerably hot, will be sufficient to wipe it out, and the valves will ride on the tappets and leak. If it is too large, the tappet will not come in contact with the valve stem as quickly as it should and the valve will open late as a consequence. By the same token, when the valve is being closed, the tappet will reseat the valve too quickly so that the valve will not stay open as long as it should and a loss of power and a tendency for the engine to overheat will be one result; noisy operation due to the slap of the tappets against the ends of the valve stems will be another annoying result.

The tappet clearance, as it is called, should be between $1/16$ and $1/32$ of an inch, preferably as close to the smaller dimension as possible. It will vary on different engines, but this is a fair average. It is measured by inserting a slip of metal of the proper thickness between the tappet

top and the valve stem (Figure 67). The clearance is properly adjusted when the engine leaves the factory, but it will be affected both by wear of the tappet, cam and valve stem, causing enlargement, naturally, and by valve grinding, which lowers the valve with relation to the cylinder and causes a diminishing of the clearance.

Attention to Valves—The valves require more or less regular attention. It is essential that they

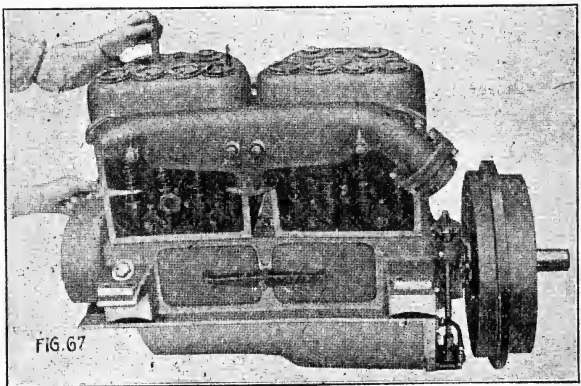

Fig. 67. Adjusting tappet clearance on Waukesha engine.

seat properly in the cylinder seats in order to prevent leakage of the compressed gases on the compression stroke and the explosive pressure on the power stroke, for leakage means impaired power and loss of snap and "pep" in the operation of the engine.

Valve grinding on any engine is not a difficult matter. To accomplish it, first drain the engine, then remove the cylinder head in the same manner as indicated for carbon removal under cylinder repairs, exposing the top or heads

of the valves where possible. On the left side of the engine will be found two valve covers; pressed steel plates held in place with two thumb screws. They should be removed, exposing the valve springs and upper ends of the cam followers. Now with a valve lifting tool, with fork placed under the valve stem and chain or link fulcrum adjusted so that you get a good purchase (Figure 68), lift the valve spring, holding down the valve head. Holding the spring in the raised position, pull out the pin passing

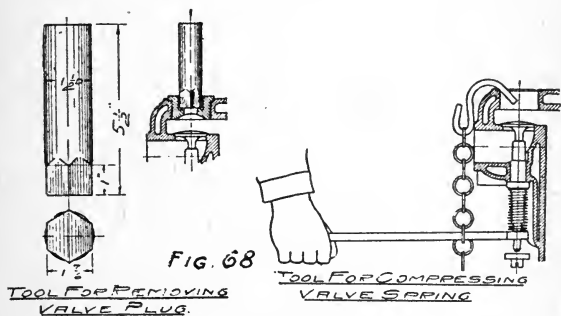

Fig. 68. Tools for removing valve cups and valves.

through the lower portion of the valve stem and which holds the valve spring washer on the stem. Release the spring and lift out the valve which will then be free.

It is well to remove all the valves at once; they are numbered, and the cylinder seats are numbered to correspond, so that no difficulty will be experienced in getting them back in proper order. Now take some coarse valve grinding paste and apply a thin coating of it evenly all around the bevel surface of the valve and replace it in position. Then with a valve grinding tool, which is a brace-like tool with a head pro-

vided with two prongs which are adapted to fit into the two holes formed in the valve head (sometimes the head is slotted to take a screw-driver bit) rotate the valve back and forth from a quarter to a half revolution, Figure 69. Do not rotate it to the full revolution, as it is apt to cause scratching of the valve and its seat. After half a dozen twists of this nature, lift the valve from its seat and put it in another position and repeat the operation.

Continue this process for a while, then wash off the valve, wipe off the seat and note the condition. When the valve is right, the bevel surface should show a ring of contact with the seat extending entirely around the valve, of oxidized silver appearance, free from pit marks and black lines and free from scratches and ridges. The seat should also be free from pits and scratches. When this result has been achieved, wash off the coarse paste and apply the fine or finishing paste and grind for a while to remove any slight marks resulting from the use of the coarse paste.

When all the valves have been ground in, put them back in the cylinder and proceed to put on the valve springs, washers and pins by the same method as they were removed. Then replace the cover plates and the cylinder head, water pipe and plug cables.

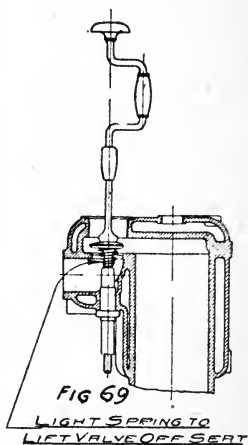

Fig. 69. Method of grinding valve to seat.

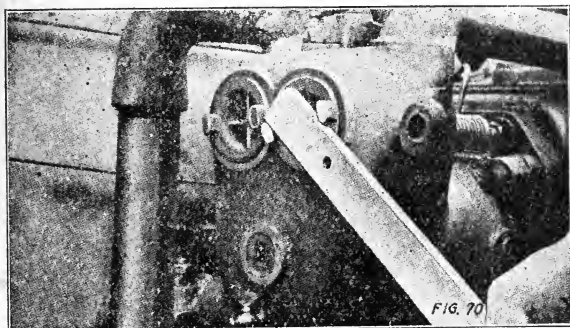

Fig. 70. Valve grinding shown in picture. 1st. Remove valve plug, by using a short flat bar.

Care should be taken in grinding in the valves to see to it that none of the grinding paste gets into the cylinders or the valve stem guides. If only a little paste is used at a time, and washing off the valve and valve seat is carefully done, there will be no trouble on this score. An-

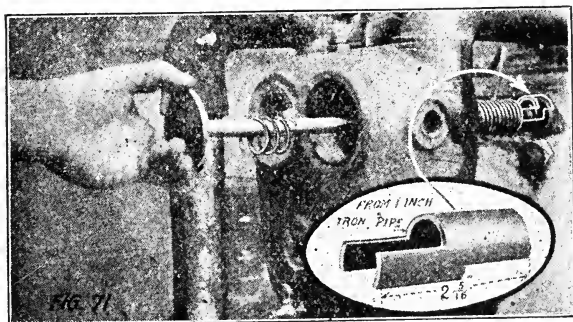

Fig. 71. 2d. Remove valve spring by turning engine over until the spring is compressed to its utmost. Place a short piece of gas pipe (sawed as per illustration) between the spring and crank case to hold spring in a compressed condition, then turn motor over until the key can be removed from the valve stem. It is not necessary to remove the spring when grinding.

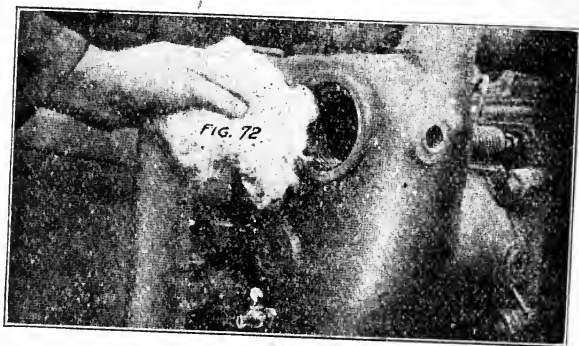

Fig. 72. 3d. Put waste in the hole to catch any valve grinding compound or sediment that may drop.

Another point to watch is to make sure that the valve is entirely free from the cam when you are grinding. Sometimes the valve will be slightly raised by the cam, when, of course, all the grinding in the world will not put the valve in good condition, since it is simply rotating on the valve stem and not on its seat.

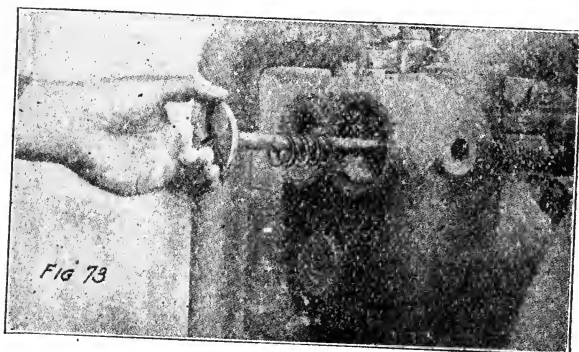

Fig. 73. 4th. Put a spring on valve stem. 5th. Put the grinding compound on the valve; don't put on too much at a time.

Figures 70 to 74 illustrate the method to follow in an engine with horizontal cylinders and heads not removable, while Figure 75 shows the method to pursue with a valve-in-head engine.

If the valves are very badly ridged and the valve seats are in poor condition, reseating must

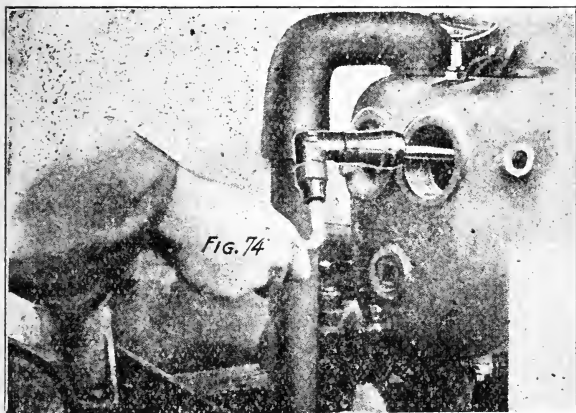

Fig. 74. 6th. Use a wide-faced screwdriver-shaped iron, in a common brace. 7th. Press valve against valve seat and give a turn to the right, release pressure, then press again and turn to the left. Keep this up until a good seat is made. 8th. When the grinding is finished, remove the valve and clean away all the valve grinding compound so it does not get down into the combustion chamber and get to cutting the cylinder rings or piston.

be resorted to. A reseating tool can be obtained at any supply store; it is simply a tapered reamer. Care should be exercised in using it not to take too deep a cut, which may affect the clearance between the valve stem and the tappet and make shortening the valve stem necessary. A valve truing tool is made for putting the valves into good condition; it acts in a manner similar

to the reseating tool except that instead of fitting into the seat and being turned around, the valve fits into the tool and is rotated against several cutting edges which correctly bevel it. After reseating the cylinder seats and trimming down the valves properly, they must be ground in to a perfect fit as indicated above, since the cutting tools do not leave them in condition to seat perfectly.

If a good, true lathe is handy, there is no need

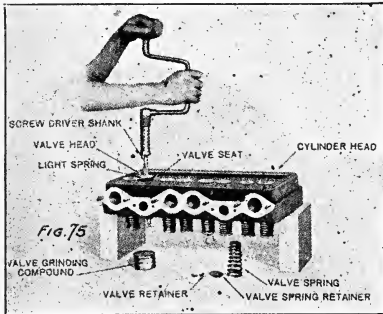

Fig. 75. Grinding valves on "valve-in-head" engine.

for using a special tool to trim down the valves, since they can be mounted in the chuck of the lathe and rebeveled with little or no trouble. Care should be exercised to set the slide rest on

the lathe to the correct angle to insure a perfect fit of the bevel surface on the valve with the bevel of the cylinder seat; care should also be used not to mar the valve stems when mounting them in the lathe chuck.

If, when the valves have been removed, it is found that the head is warped so badly that trimming down the valve will not bring it into proper shape, the best plan is to discard it and replace it with a new valve. Sometimes it will be found that the head is not perfectly true with the stem. This can generally be corrected by replacing the valve in the cylinder, making sure that it is off

the cam, and giving it a good sharp whack in the middle, using a soft drift of brass or mild rolled steel to take the actual hammer blow and protect the cylinder against damage should the hammer aim be poor. Where the valve stem is found to be badly bent, it is best to insert a new valve and not to bother with the old one, as it is very likely to stick in its guide and render the cylinder inoperative. When grinding the valves and before

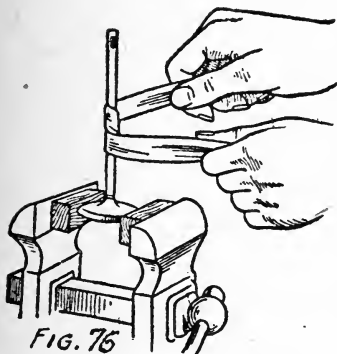

Fig. 76. Method of polishing the valve stems.

replacing them, remove all the carbon deposit from both the upper and lower sides of the valve head and clean the valve stem, removing any carbonized oil and roughness with a strip of emery cloth used as shown in Figure 76. The emery cloth should be carefully used so as not to take

too much off the valve stems, for it is essential that they be a comparatively tight fit in the valve stem guides. There should just be freedom enough for them to slide up and down easily without any tendency to stick; the looseness should not be appreciable.

If any of the valve springs are found to be weak and not of the same length as the average spring, it is well to replace the poor ones with new springs. A weak spring, especially on an exhaust valve, will have a tendency to cause the engine to lag and run unsteadily, the cause of which sluggish action is difficult to locate.

Generally, valve grinding and carbon removal are done at the same time, since both will be necessary at about the same intervals, and both require disassembling the engine to about the same degree. It is well, therefore, to count on grinding in the valves each time the engine is taken down for carbon removal.

While the method of checking up on the timing of the valves will differ with every individual make of engine, as indeed the timing of the valves will differ, if the method to be followed in any one engine is applied to other makes, the tractor operator will not be far from wrong. It is a fact that with most engines the timing of the valves with relation to the crankshaft is indicated by distinct markings on the flywheel which show exactly when a valve should open and close, and give indication of wrong timing in case loss of power cannot be attributed to any other cause. The following method applies to the Twin City tractor engine and indicates clearly the procedure on similar motors:

Markings on the Flywheel—The diagram, Figure 77, shows the points at which the valves in one cylinder open and close. It must always be remembered that it takes two complete revolutions to complete a four-cycle phase.

Now suppose the center mark on the flywheel is in line with the pointer located on the center line of the motor. By rotating the flywheel to the right, the first mark indicates the point at which the exhaust valve just closes.

The next mark is the point

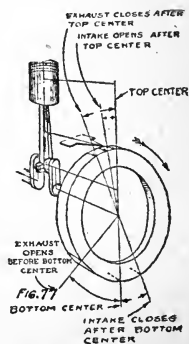

Fig. 77. Timing engine by flywheel markings (Twin City).

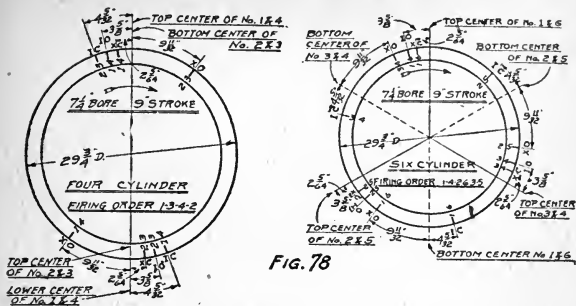

FIG. 78

Fig. 78. Timing diagrams for Twin City engines.

at which the intake valve is just commencing to open and remains open (which is the suction stroke) until the intake closing mark is reached, which is located past bottom dead center or opposite the intake opening mark. Continuing to rotate compresses the charge until the top center mark is reached, when the electric spark ignites the charge.

When starting a motor the spark is retarded or takes place after piston is on top center, but when motor is up to speed and the maximum power is required, the spark takes place before top center is reached, which is the advance posi-

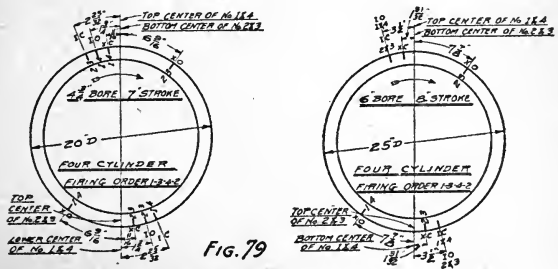

FIG. 79

Fig. 79. Timing diagrams for Twin City engines.

tion. This can be done because the high speed makes it possible to reach top center and past before the gas is really ignited and expanded:

Advancing the spark too far will make the motor pound, which is caused by the explosion taking place too early and the full force is applied when the piston is still compressing the charge.

Continuing to rotate until the next point is reached is the exhaust just commencing to open. This will remain open until the exhaust closing point is again reached.

To place any one piston at the top center, rotate the flywheel until the intake closes and the center mark on the flywheel next reached will bring that piston in the top center position.

The position of the marks on the flywheel, measuring along the circumference, is as follows:

	I. C. 40 & 60	I. C. 25	I. C. 15
Intake opens past top center.....	$3\frac{5}{8}$	$3\frac{1}{2}$	$1\frac{3}{4}$
Intake closes past lower center..	$4\frac{5}{32}$	$3\frac{1}{2}$	$2\frac{25}{32}$
Exhaust opens before lower center	$9\frac{11}{32}$	$7\frac{7}{8}$	$6\frac{9}{16}$
Exhaust closes after top center..	$2\frac{5}{64}$	$1\frac{31}{32}$	$\frac{11}{16}$

These are illustrated graphically in Figures 78 and 79.

EXACT SETTING OF VALVE FOR PROPER TIMING ON MOTOR OF BULL TRACTOR.

Set so that exhaust valve opens 36° before center.

Set so that exhaust valve closes 8° after center.

Set so that intake valve opens 14° after center.

Set so that intake valve closes 20° after center.

INCHES ON FLYWHEEL.

$$36^\circ = 8\frac{5}{32} \text{ inches.} \quad 8^\circ = 1\frac{13}{16} \text{ inches.}$$

$$14^\circ = 3\frac{3}{16} \text{ inches.} \quad 20^\circ = 4\frac{17}{32} \text{ inches.}$$

Time of opening or closing, stated as before and after center, refers to direction of motor rotation.

All opening and closing distances shown should be measured on flywheel rim only and from center arrow.

Never remove flywheel from crankshaft without marking position so you will get it back just as it was before removed.

Crankshaft and camshaft gears are marked and set as follows:

Short or R. H. shaft set to marks Nos. 1.

Long or L. H. shaft set to marks Nos. 2 (Figure 80).

After the valve grinding operation, of course, it always will be necessary to readjust the valve

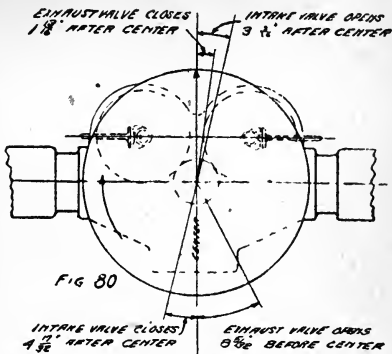

Fig. 80. Timing of Bull tractor engine.

tappet clearance to bring it back to the manufacturer's specifications. Like the valve timing checking, the method to be followed in effecting this adjustment will depend to

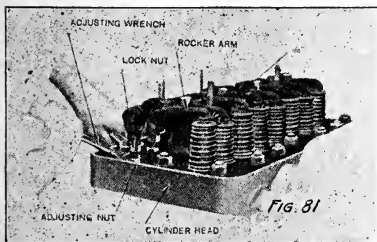

Fig. 81. Adjusting push rods on overhead valve engine.

a greater or less extent on the type of engine, and especially on the type of valve arrangement employed.

Figure 67 indicates clearly the method to be followed in effecting the adjustment on an L-head engine, a rule or stick being employed to determine the position of the piston with relation to the stroke and a feeler gauge used to determine the proper clearance. The adjustment of the tappets is made by opening the locknut holding the tappet adjusting screw in place on top of the tappet and unscrewing the screw slightly to take up some of the clearance in case of wear, or screwing it down in case the adjustment is too tight. Figure 81 shows how the adjustment is made in the case of an overhead valve engine, the picture illustrating the method of adjustment used in the case of the Case 10-18 model.

CHAPTER V.

About the Fuel System.

Some Thoughts on the Fuel Burned in Tractor Engines and the Means for Obtaining Best Results.

WHILE in the automobile field we find that gasoline is the universal fuel, and that practically every make of car and truck is adapted to burn this light hydrocarbon fuel and none other, this standardization of fuel is by no means apparent in the tractor industry.

The reason is not hard to find. The tractor engine, operating as it does on almost full load throughout the entire day, consumes considerable fuel (Fig. 82); if, then, we employ a low-cost fuel as against a high-cost one, other things being equal, the cost of operation of the tractor is greatly reduced.



Fig. 82. The gasoline tank tells the story. Exact relative size of gasoline and oil fuel tanks on the 14-28 Oil Pull Tractor.

As has been repeatedly pointed out in the case of the tractor engine, flexibility is not required to anywhere near the same extent as with the automobile engine; the use of kerosene, therefore, is not at all objectionable, always provided the means for handling it are sufficiently well carried out so the engine will idle while hitches are being made, and other adjustment effected preparatory

to starting in on the hard work, and immediately pick up and carry the full load without faltering or loading up.

Where kerosene has failed as a motor fuel for tractor service, the fault has been that idling was generally followed by bad operation, due to the reduction of temperatures, so that when the throttle was opened to give the full load, the heavy fuel was not properly handled.

An internal combustion tractor motor to perform the function of burning kerosene in the most successful and advantageous manner must embody in its design and construction the following elements:

1. A double carburetor with one side connected to the gasoline supply tank, which can be properly adjusted and used for starting and heating up the engine.

2. The other carburetor connected to the kerosene or distillate supply tank and properly adjusted so that the intake air lines to the motor may be instantaneously switched from communication with one carburetor to the other, as the circumstances may require.

3. The pipe lines from the kerosene or distillate tank must be through some portion receiving heat from the exhaust that will raise the temperature of this low-grade fuel to a point not above 90 degrees F., nor below 75 degrees F.

4. The kerosene carburetor must have its inlet connected to a housing around the exhaust pipe so that when the exhaust pipe becomes heated the air passes into the carburetor at a temperature not below 80 degrees.

5. With the air and the fuel at the respective temperatures above given, meeting in the carburetor, the mixture is readily formed.

6. The mixture thus formed must be turned into gas (air-charged kerosene is not yet a gas). Therefore, in traveling through the intake pipe, it must be brought into contact with the surfaces of the intake pipe, made hot on the exhaust pipe (called a gasifier—Figure 83). Passing over these heated corrugated surfaces in a circular path and finally traveling upwards into the cylinder, the centrifugal action throws the heavier particles of kerosene against the heated wall, and

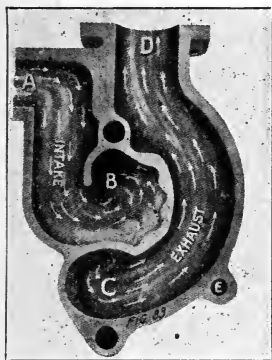

Fig. 83. Cross-section of the Avery gasifier.

A—Fuel mixture coming from carburetor and entering gasifier.

B—Fuel mixture thoroughly gasified and entering cylinder.

C—Exhaust coming from cylinder.

D—Exhaust exit.

E—Fuel heater.

the heat transforms the kerosene-charged air into a dry gas which will instantaneously fire and burn quickly and completely.

7. In the passage-way between the gasifier and the intake valve, a valve must be provided through which outside air can be taken in, which will temper this gas mixture and reduce the temperature of it, and thereby prevent the loss through expansion due to the temperature required to gasify the mixture.

8. Provision for injecting water (Fig. 85) with the kerosene and low-grade fuels is necessary to prevent carbon deposits and knocking due to preignition. It is not necessary to start the water for a few minutes, and under some conditions of temperature very little water is required. When preignition

takes place, water is required, but only just in sufficient quantity to prevent the knock. Too much water is indicated by a white vapor through the exhaust of the engine.

9. The thermo-syphon system of circulating

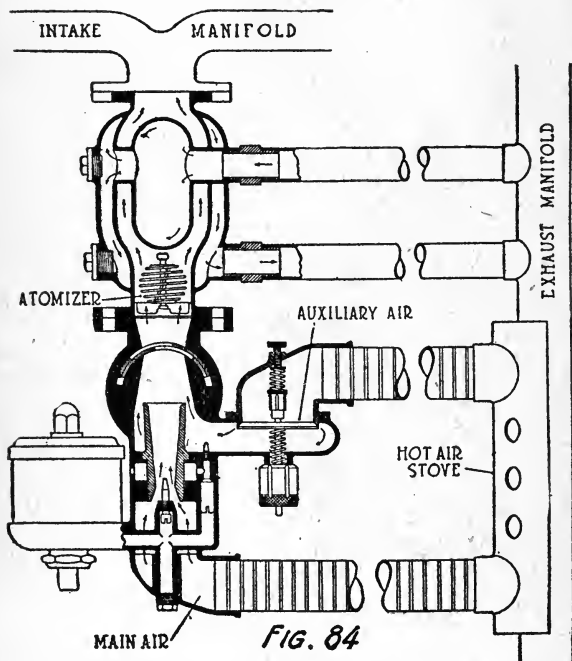

Fig. 84. Section through Buckeye-Deppé Integrator, showing carburetor arrangement for heating the fuel and air and the mechanical atomizer in the form of a whirling fan placed above the special center-opening throttle.

the cooling water is beneficial in the matter of burning kerosene, because it automatically starts the water circulating as soon as sufficient heat has been generated within the engine for burning the heavy fuel. A circulating pump is not

so desirable, because at certain seasons of the year the cooling water is circulated too fast for the temperature prevailing and keeps the temperature of the water too low for good operation, causing condensation in the cylinders; and when the mixture is not thoroughly gasified, or becomes condensed, passage of the fuel by the pistons is sure to be the result.

While kerosene is greatly used in the tractor field, its increasing price, bringing it well up

into the price class with the lighter gasoline, coupled with the fact that certain difficulties have resulted in a good many installations, because the principles on which the proper operation of a kerosene engine depended have not been fully understood, have resulted in many tractor engineers retaining the gasoline fuel in preference to the kerosene.

Both gasoline and kerosene are more or

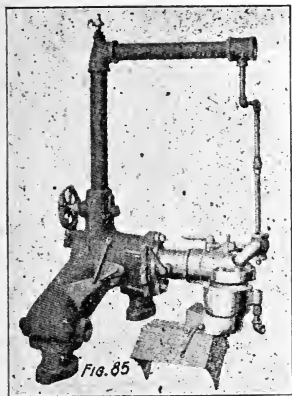

Fig. 85. Aultman-Taylor heavy fuel carburetor showing water injection apparatus.

less volatile liquids obtained from the distillation of crude petroleum. This heavy, black, smelly oil, which is drawn from wells which flourish in several parts of the United States and in many foreign countries, is put into a still and the temperature raised until certain of the lighter constituents contained in the crude oil boil off.

The first vapors to pass off are too light for use as motor fuel, and the general process is to

condense them and pass them back into the still, where they assist in breaking up the heavier constituents, producing the lighter hydro-carbons which are adaptable for internal combustion engine use. After all the light vapors have passed off, the temperature is elevated slightly and boiling again takes place, and we have another yield of vapor which, when condensed in a cooling coil outside the still, is found to possess a boiling point somewhat higher than the first fraction to come over on the starting process.

This process of boiling off all the liquid that will distill at a given temperature and collecting the condensed liquid, then elevating the temperature slightly, causing the next fraction to distill over and piping the distillate into another tank, is continued until nothing is left in the still except residue. Roughly, the process yields gasoline, naphtha, benzine, kerosene, distillate, heavy fuel oil, light lubricating oils, medium lubricating oils, heavy lubricating oils, petroleum jelly, paraffin wax or asphaltum, when the crude oil is of asphalt instead of paraffin base.

This classification is very rough. As a matter of actual fact, the number of liquids with different boiling points that can be separated from the crude oil is almost indefinite, so that any one of the above-mentioned oils really consists of a large number of oils of different boiling points, with these boiling points falling within a given range.

Good gasoline will consist of liquids with boiling points between 100 degrees F. and 350 degrees F.; its specific gravity—weight of a cubic inch of gasoline at a given temperature compared with an equal volume of water at the same temperature—or its Baumé reading, which gives a similar comparison by another standard or scale,

has no bearing on its value as a fuel, a point which the average operator finds it hard to believe.

What we really want in a gasoline motor fuel is one which will vaporize readily; that is, one in which the whole body of the fuel will vaporize within a comparatively short temperature range. We can have such a fuel, and its gravity as given by Baumé reading may be 56 degrees; but provided the boiling points of its various constituents are within a comparatively short temperature range, and the maximum temperature is not so high as to preclude ready vaporization of the fuel at ordinary temperatures, it will be a good fuel.

If, on the other hand, we have a fuel made up of one distillate—say, for instance, kerosene with high boiling point and low gravity—and some other hydro-carbon such as first comes over from the still with very low boiling point and high Baumé test, the average or mean Baumé test of the two mixed together may stand as high as 70 or 75 degrees Baumé and the fuel will not be as good for motor use as the first with lower Baumé test. The reason is easily found; the lighter portion of the fuel will vaporize readily, making the engine easy to start, but will leave behind the heavier portion of the fuel, not so readily vaporized, which will be troublesome.

It is readily seen, therefore, that it is fallacious to attempt to judge the quality of gasoline by the specific gravity or Baumé tests, either of which tests are carried out with an instrument called a hydrometer, differently graduated in accordance with which standard is adopted. The only reliable test to determine the value of a fuel is the distillation test, which gives the range of the

boiling points of the constituents of which the fuel is composed.

In the case of kerosene fuel, we have not the real need to worry over the distillation curve or any other form of test, for it is a fact that any engine adapted to handle kerosene properly will work well with any kerosene which the present market affords.

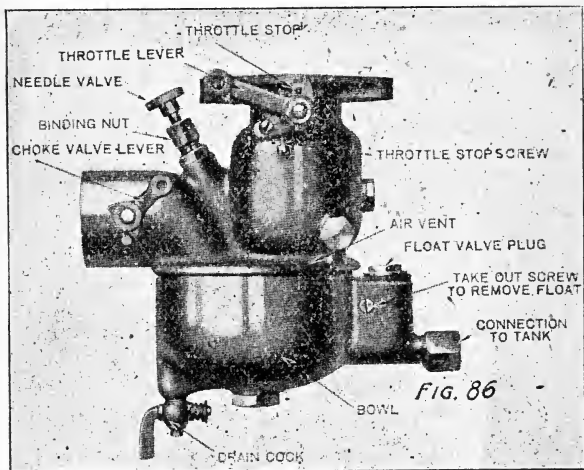

Fig. 86. Carburetor from Case 10-18 tractor.

While, as indicated above, there are some special conditions to be taken into consideration when kerosene is the fuel used, in the broadest sense the principles upon which the vaporization of the fuel depends does not vary. With either fuel in tractor application, we employ a carburetor (Figure 86) to assist in the operation.

The purpose of the carburetor is three-fold. It is a fact that no substance, be it air or solid, will take fire and burn until converted into the

gaseous state. The quicker the substance is converted into the form of a gas, the more rapid will the combustion be. It stands to reason, therefore, that in order to obtain very rapid combustion of our fuel we must convert it to a state where it will be very rapidly transformed into a true gas which will readily take fire and in burning liberate the desired quantity of heat to accomplish the work on the top of the piston.

That is the primary function of the carburetor. It is so arranged that it divides the liquid into an infinite number of very fine particles; breaks it up, pulverizes or atomizes it so that the fuel, being held in suspension in the air after emerging from the carburetor where it has undergone this treatment, is in fine condition to be readily converted into a true gas. This result is brought about in very much the same manner as perfume is sprayed from an atomizer. In the carburetor there is a nozzle which corresponds to the spray nozzle of the atomizer, and the rush of air across the orifice of this nozzle occasioned by the suction of the cylinders when the pistons are going down on their intake strokes, causes the fuel to flow from this nozzle in the form of a fine spray, which is taken up by the passing air column and carried into the cylinders.

It is also a fact, that any substance which is burning combines in definite proportions with oxygen gas which is present in the air. For complete combustion of any fuel a given amount of this gas must be supplied for a given amount of the fuel; if the oxygen is drawn from the air a fixed amount of the air sufficient to supply the required amount of oxygen must be supplied or else the combustion will not be complete.

It so happens that with gasoline, in order to supply sufficient oxygen, 16 times as much air

by weight is required as of gasoline. Such a mixture of gasoline and air, with the fuel thoroughly vaporized, would be the theoretically perfect mixture. There is present in the air, however, an inert or inactive gas called nitrogen, which retards the speed with which the mixture will burn, and in order to counteract the slowing up effect of this inert gas it is necessary to supply a greater amount of fuel than one part to sixteen, and so the usual carburetor, when in good adjustment, is set to supply approximately ten times as much air by weight as of fuel; this is the practical ideal mixture, while the 16 to 1 mixture is the theoretical ideal one.

The second function of the carburetor is to proportion the amount of fuel to air to maintain this correct mixture throughout every condition of speed and power. If the carburetor does not maintain this mixture correct, it is evident that at some speeds we will have a mixture with an excess of fuel present which will be slow-burning, sluggish and wasteful of fuel and we will not get full power from the engine. At other speeds we will get a mixture with an excess of air, which also will be slow-burning and from which we will not get sufficient heat and pressure to cause the engine to develop full power, while at other speeds we will get a perfect mixture and the engine will perform well.

The modern carburetor has been developed to a point where it will maintain this most necessary constancy of mixture proportions throughout the entire speed range of the engine, giving us flexible operation, economy from the fuel standpoint and maximum power—but above all, perfectly steady and reliable operation, with no tendency for the engine to falter, stop or stall.

The carburetor is one other important func-

tion to perform which is sometimes overlooked. It incorporates in its makeup a shutoff valve applied to the passage, by which the mixture leaves the carburetor and finds its way to the intake manifold, through which it is conducted to the cylinder. This is the throttle valve, and its purpose is to control the amount of mixture delivered to the cylinders and consequently the power developed by the engine and the speed or pulling ability of the engine.

It will be well, perhaps, to give some thought to basic principles on which carburetors as a whole depend. In order to eliminate complications, for the present, let us consider that the throttle valve is missing and that the carburetor consists of a simple nozzle or jet protruding into an air passage connected with the cylinders. If we neglect the friction of the air piping, it is evident that the amount of air which will pass through the pipe will be proportional to the speed of the engine. In other words, the engine acts as a pump; at a given number of revolutions per minute it will pump a certain amount of air, depending on the piston displacement; at double that speed it will pump very nearly twice as much air.

The force which is actually causing the air to flow into the cylinders is the pressure of the atmosphere. The pistons are drawing the air out of the manifold, reducing the pressure in the manifold from about 15 pounds per square inch, or atmospheric pressure, to something less than that amount, depending on the speed of the engine. Let us suppose that at the lower speed cited in the case above, the pressure in the manifold was reduced to 10 pounds per square inch; then at the air opening on the carburetor we have an effective pressure of five pounds per square inch, causing the air to enter and flow

through the tubing or piping to the cylinders. If now we double the speed of the engine we still further decrease the pressure in the manifold, let us say, to five pounds per square inch, so that we have a pressure of ten pounds per square inch forcing the air through the piping; and naturally its flow will be somewhere near double the rate at lower speed and approximately twice as much will pass through in a given time.

This reduced air pressure in the manifold is important, as is also its variation with the speed of the engine. In the nozzle which projects into the air pipe we have the fuel, the level controlled so that it stands just at the top of the jet. When the air pressure is reduced in the manifold, since we have the pressure of the atmosphere acting on the other end of the fuel line leading to the nozzle, we naturally have a pressure exerted to force the fuel out of the nozzle into the manifold where it mixes with the rapidly moving air column. The fuel is atomized by passing through a comparatively fine nozzle, sometimes of special shape. This atomization is furthered by the rapid movement of the air column.

Naturally, at higher speeds, with the manifold pressure reduced, we are going to have more pressure action on the liquid column, tending to cause it to flow at faster pace and in greater quantity into the manifold. If the laws governing the flow of air through tubing under reduced pressure and those governing the flow of liquids through nozzles under reduced pressure were the same, it is evident that from this simple arrangement we would get a constant mixture of gasoline and air at all speeds.

Such, however, is not the case. The flow of liquid through the nozzle increases more rapidly with the falling off in manifold pressure than the

flow of the air through the pipe so that at high speeds we get a mixture with an excess of fuel, or, as we say, an over-rich mixture.

If, therefore, we adjust the fuel nozzle so as to give us the correct mixture at low speeds, it is evident that at high speeds we are going to get a rich mixture. If, on the other hand, we adjust it to give us the correct mixture at high speeds, at low speeds the mixture is going to be

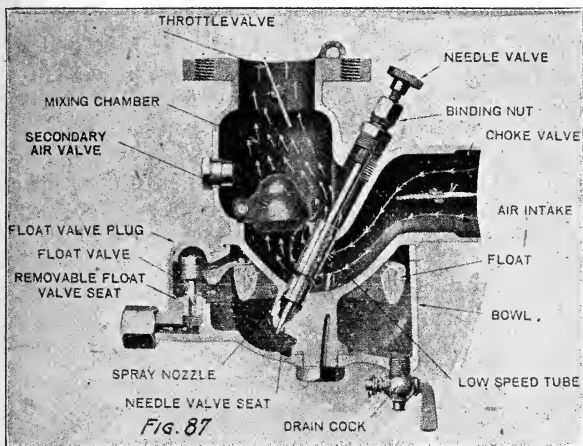

Fig. 87. Sectional view of carburetor.

lean—there will not be enough fuel for the amount of air supplied. This result is due to the difference in flow between the air and the liquid columns under the differing manifold pressures.

If we bear this relation distinctly in mind, we will not have the slightest difficulty in thoroughly grasping the construction and the principles of operation of the carburetor applied to almost any tractor engine. One from a Case 10-18

tractor is shown in cross-sectional form to make its construction plain, in Figure 87. The fuel enters from the tube leading from the tank at the point marked "Float valve" and flows down into the bowl of the carburetor. In this bowl there is a cork float in the shape of a ring to which is attached a small lever hinged or fulcrumed to the top of the float chamber. The other arm of this lever is arranged to press against the gasoline intake needle. As the float rises with the level of the incoming gasoline, it gradually brings the lower or pointed end of this needle into contact with a valve seat, clearly indicated in the figure, and closes off the gasoline so that no more can enter the bowl. This float mechanism is so arranged as to maintain a constant level of the fuel in the float chamber at all times.

The air enters the carburetor through a horizontal passage on the side marked "Air intake," and this passage is bent downward to form a well, and at the same time its diameter is decreased so that at the deepest section of the well the area of the passage is at a minimum. Just at this point is located a needle valve passing through the well and closing the gasoline passage between the well and the float chamber. Normally, this valve is opened just enough to provide sufficient gasoline for full power operation of the engine. The needle valve, however, permits of very accurate regulation of the amount of fuel which can enter the air passage from the float chamber.

Coming up from the well, the air passage broadens out again and takes a vertical path, and just where it enters into the comparatively broad mixing chamber is placed a hinged valve, called the secondary air valve. It will be appreciated that this valve will be fully closed, due to its

own weight, which is carefully proportioned to the conditions obtaining on the Case engine, so that the passage of the air is stopped or nearly stopped.

Reference to the diagram will show that the needle valve proper is surrounded with a cylindrical passage or air bypass, by means of which a certain limited quantity of air can pass into the mixing chamber from the well even with the secondary air valve closed. When the suction on the manifold increases, due to increased work being done by the engine, as when the throttle is opened, the air valve opens automatically, permitting an increased amount of air to enter the mixing chamber.

The float valve is so arranged that it maintains the mixture exactly at the proper level to permit a slight overflow into the well, maintaining a puddle when the engine is not in operation. Considering now that the engine is cold, the operator will turn the engine over and the entering air will rush through the well at very high velocity, due to the constricted passage. The high velocity, however, entails a drop in pressure, so that at the spray nozzle controlling the entrance of the fuel into the well we will have a partial vacuum formed. The flow of gasoline into the well will, therefore, be started automatically the instant the engine is turned over, and the amount flowing will depend on the velocity of the air and the suction which it creates in the constricted passage.

The entering air will impinge on top of the puddle and supply the excess amount of gasoline to air mixture in order to provide a rich mixture for starting while the engine is cold; after the first few revolutions, however, the well will be sucked dry and all the gasoline supplied will

come through the needle valve and the spray nozzle. But at the spray nozzle the air passage, considering low speeds, is greatly narrowed, forcing the air to assume very high speeds through the cylindrical bypass around the needle valve. The high velocity entails great suction so that sufficient gasoline is drawn through the needle valve in order to provide the constant mixture for low throttle operation.

The opening of the secondary air valve proportions the amount of air flowing directly into the mixing chamber to the amount flowing through the bypass, and consequently regulates the suction on the needle valve in exact accordance with the amount of air flowing to provide just the correct gasoline flow to determine a constant mixture.

From the carburetor the mixture passes into the inlet manifold, which is a branched pipe leading the mixture to the intake port on each cylinder; the amount of mixture entering the manifold is controlled by the throttle valve, which is simply a disc of brass of a diameter substantially equal to the internal diameter of the mixture passage in the carburetor and mounted on a horizontal spindle which when turned by the lever sets the disc either to close the passage or open it, or to give any desired intermediate opening as required by the operating conditions and the amount of power it is desired to take from the engine. As a matter of fact, the throttle valve never comes to a fully closed position when the carburetor is in correct adjustment; there is always a slight opening maintained by a screw adjusted stop on the throttle lever so that even when the throttle control lever is fully closed, sufficient fuel will pass the valve to keep the engine running at low speed—idling, as it is termed.

A second butterfly valve is placed in the air intake pipe on the carburetor; it is called a choke valve and is operated by a lever. Normally, with the engine running, regardless of speed, this valve stands fully open and is held so by a spring. In starting, however, especially in chilly weather, it is desirable to provide a rich mixture; considerably richer than the running mixture, because with cold air the gasoline is harder to convert into a true gas; less of it is so converted and more must be supplied to make up for the

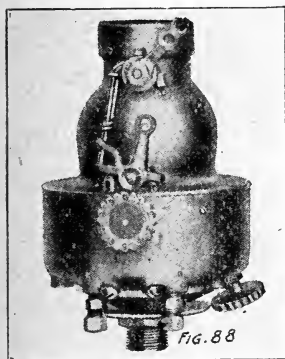

Fig. 88. The Linga Vaporizer.

deficiency. Instead of supplying more gasoline by opening the needle valve further, the choke valve is partially closed so that less air is supplied, which also has the effect of reducing the atmospheric pressure in the mixing chamber of the carburetor so that there is a large flow of fuel into the well, the combined strangulation of the air and increased flow of gasoline giving the necessary rich mixture for starting.

The cup or bowl of the Linga carburetor (shown in Figures 88 and 89) has three compartments—for gasoline, kerosene and water. Each compartment has a float.

The gasoline, which is used for starting, and the kerosene are both supplied to the engine through a common opening controlled by the fuel needle valve (8). The water is fed through the water needle valve (11).

To change from gasoline to kerosene, or the reverse, it is only necessary to tilt the fuel switch (12) from one side to the other. When tilted to the right it holds the kerosene needle (10) down on its seat, which closes the opening between the kerosene compartment and the fuel needle valve. In this position the gasoline needle (9) is lifted and gasoline is admitted to the fuel needle valve.

If the fuel switch (13) is tilted to the left the gasoline passage closes and that of kerosene opens. If the switch (13) is placed in a vertical or middle position the vaporizer will feed a mixture of half gasoline and half kerosene.

The kerosene needle valve has a stronger spring than the gasoline needle, so ordinarily the kerosene passage will remain open and close the gasoline passage. For starting

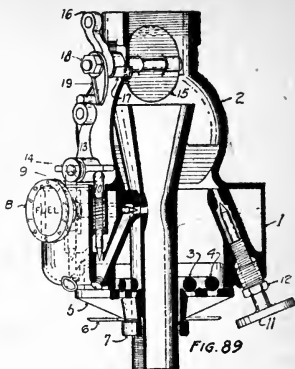

Fig. 89. Sectional view of Linga Vaporizer.

Linga Vaporizer Parts.

1. Bowl with three compartments.
2. Vaporizer Body.
3. Auxiliary Air Valve.
4. Auxiliary Air Valve.
5. Valve Cage.
6. Drip Bell.
7. Nut.
8. Fuel Needle Valve.
9. Switch Needle.
10. Switch Needle.
11. Water Needle Valve.
12. Packing Nut.
13. Fuel Switch.
14. Fuel Switch Nut.
15. Throttle Valve.
16. Throttle Lever.
17. Throttle Stud.
18. Throttle Nut.
19. Connecting link or throttle lever shoulder.
20. Spring.
21. Spring.
22. Float Valve Screw.
23. Float Needle.
(Bronze Balls are used on some sizes).
24. Float Arm.
25. Float.
26. Stud.
27. Compression Coupling.
28. Throttle Screw.
29. Drain Cock.

on gasoline the fuel switch must be tilted to the right and held there by fastening the thumb nut.

The air intakes are at the bottom. The initial air (about one-fifth of the total) is drawn through the nozzle tube in the center. This is the hot air taken from a jacket around the exhaust pipe. The fuel is drawn into this hot air jet and evaporated.

The auxiliary air is admitted through the two annular slots around the center tube. The valves are two annular rings of such weights as will insure the best running of the engine at high and low speed.

The governor on the engine acts directly on the butterfly valve of the carburetor. You will notice a little projection or shoulder fastened to the butterfly valve lever by means of a nut. When the engine is running idle or empty the butterfly valve or throttle closes and this little shoulder strikes the fuel switch, tilting it just a trifle and thus admitting a small amount of gasoline with the kerosene. Thus the full flexibility of the engine is preserved.

The carburetor is very simple. After removing the hot air intake, the bowl of the carburetor can be removed by turning off the large thumb screw at the bottom. A screwdriver is the only tool required to remove the floats and valves to allow cleaning the fuel passages.

The Rumely carburetor used on the Model 14-28 tractor is very simple, and is free from floats, springs and internal automatic mechanism or complicated parts, requiring frequent adjustment, or changing to suit damp or dry weather. It consists simply of a vertical tube of peculiar internal shape, surrounded by three divided chambers for kerosene, water and gasoline, each having a needle valve. Below the fuel cham-

bers the throttle valve is placed, which is coupled direct to the governor and accurately measures and proportions each charge of mixed fuel, air and water that goes into the cylinders.

The gasoline chamber is used only in starting, and as it has no other use, there are no automatic means for getting gasoline into it. A bronze plunger pump working off the camshaft lifts kerosene and water to the carburetor, the surplus draining back through overflow pipes.

A jacket on the exhaust pipe heats the intake air with means for regulating the amount of heat. This is necessary in cold weather only.

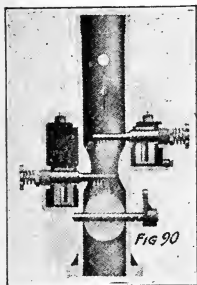

Fig. 90. Sectional view of 14-28 carburetor.

The air first goes through a cleaner where the dust and grit are removed, and then enters the top of the carburetor, passes through the venturi and mixes with the kerosene and water, the relative quantity of each being regulated by the governor controlled throttle valve located in the lower part of the carburetor. From here the mixture goes direct to the combustion chamber of the motor to be consumed.

In appearance it is merely a cylindrical tube surrounded by the fuel chambers. In outward appearance it follows general lines of carburetor construction, as practiced by builders of internal combustion engines. The internal construction, however, of the 14-28 carburetor, is radically different from that of carburetors of other builders, as Figure 90 fully explains.

Figure 90 shows a cross-section of the 14-28 carburetor. It will be noted that the central

cylindrical passage has a restricted portion forming a venturi tube. The oil fuel nozzle is located in the under portion of the venturi, while the water nozzle is located above.

Due to the peculiar shape of this passage and the relation of the nozzles to it, the proper quantity and proportions of fuel and water are *automatically* fed to the engine at all times, regardless of load.

The action of the engine piston produces a partial vacuum in the carburetor passage, and this relative vacuum in the zone marked *A* varies with the load, so that the *correct proportion of fuel is always exactly suited to the existing load.*

In the zone above the venturi marked *B*, a relatively strong vacuum prevails during the heavy loads, but decreases very rapidly as the load is reduced. At the low loads the vacuum is reduced to such an extent in this zone that no water is fed.

Thus we have a means whereby the fuel mixture is *automatically fed under governor control in correct proportions at all loads*—the water being automatically supplied in correct proportions for the higher loads only and none at all being admitted for the light loads.

The Secor-Higgins carburetor used on the 18-35 and 30-60 Rumely OilPull sizes, as may be seen in Figure 91, is divided into upper and lower sections, the upper section being again divided into three compartments. The compartment farthest to the right is for the kerosene, the middle one for water and the one farthest to the left for gasoline. All open into the lower section.

The lower section is the mixing chamber. In the bottom of this are three rectangular openings. The two openings on the left hand side admit air to the mixing chamber; the one on

the right is the opening to the manifold through which the mixture of kerosene, water and air passes directly into the cylinder. A plate which is controlled by the governor slides back and forth over these openings. The openings in this plate are arranged so that when it is pulled to the right the outlet to the cylinder is made smaller, while the air inlet is also reduced to a

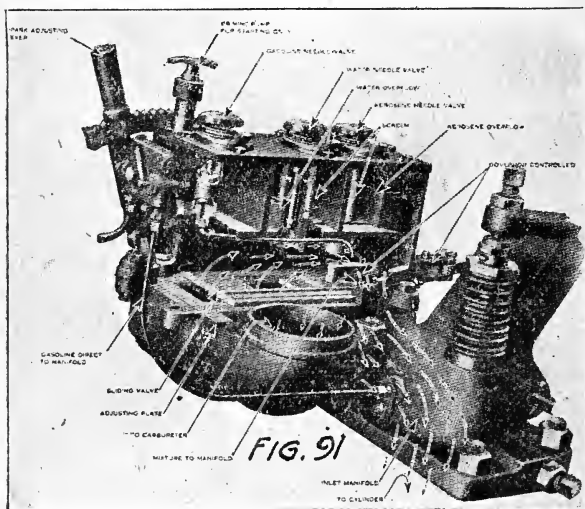

Fig. 91. Secor-Higgins carburetor, another automatic type used by Rumely.

lesser extent through the uncovering of the opening at the left hand of plate.

Needle valves in the kerosene and water chambers control the maximum amount of fuel and water to be fed. These need be set only once at full load, and the carburetor under governor control then takes care of the adjustment for all other loads.

As a general rule, with the tractor engine the fuel is gravity fed from the tank to the carburetor, the tank being located well above the level of the carburetor, so that there is little chance of failure even when the machine is working on a steep incline. While with most tractors of the kerosene burning type two separate tanks are provided, one for the small amount of gasoline needed in order to facilitate starting and to run the engine long enough to warm it up to a point where it will handle the kerosene fuel, in some instances, as for instance the Case, a double compartment tank is provided, the smaller compartment being

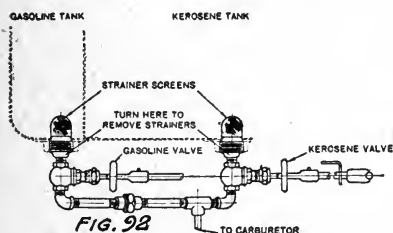

Fig. 92. Fuel connections and strainers on Case 10-18.

used for the gasoline. The arrangement of the Case tank is made very plain by Figure 92.

It will be seen that the connections are such that the kerosene can be shut off at will and the engine run on gasoline; likewise the latter can be shut off and the engine operated on the kerosene. The usual practice is to shut off the kerosene and switch on the gasoline a few moments before shutting down at the completion of the day's work so that the gasoline will have a chance to fill the carburetor bowl in preparation for an easy start next morning.

In almost every instance a strainer of one sort or another is included in the fuel line to prevent passage of sediment into the carburetor, where it is bound to clog up the nozzle and affect the running of the engine. The arrangement of the two

strainers on the Case fuel supply line—one for the gasoline tank and the other for the kerosene tank—is indicated in the figure. It is important that they be cleaned frequently.

Carburetor Adjustment.—The proper adjustment of the carburetor is, of course, a matter which will have to be determined for each individual make of carburetor and engine as well. There are no hard and fast rules for effecting adjustment which will fit all cases, or even a majority of cases. If we study the following

principles, however, we will find that they apply to all carburetors, all engines, and all fuels common to tractor practice, and will aid us much in carrying out the terse directions generally given for carburetor adjustment in the tractor instruction book furnished by the manufacturer.

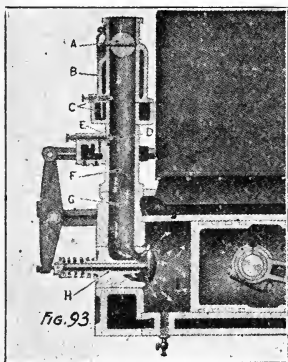

Fig. 93. Cross section of patented Mogul mixer and cylinder, showing adjustments.

wherein the fuel supply is adjustable by means of a needle valve, is to bring the needle valve gently, but fully, to its seat so as to shut off all the flow through the jet or nozzle. Care should be exercised in effecting this, not to jam the valve down on its seat and cause deformation of either the needle or the seat, as if this is done it will be almost impossible to attain a correct adjustment of the carburetor without replacing the parts

with new and perfect ones. Then turn the needle back one or two turns—depending on the carburetor and the size of the engine—and turn the engine over to start it, priming the cylinders if necessary.

Where priming is not necessary it will be well to close the choke valve on the carburetor to provide a good rich mixture for starting. With the engine running, even though it is running badly,

do not attempt to obtain a final adjustment on the carburetor until the whole mechanism has warmed up. Be sure that the choke valve is opened again immediately after the engine has started, for if it is held closed the over-rich mixture supplied will choke the engine and cause it to stop.

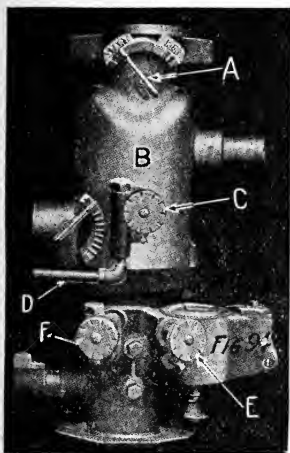

Fig. 94. View of kerosene mixer and water injector, showing adjusting devices.

After thoroughly warming up the engine, retard the spark fully and open the throttle sufficiently to allow the governor to control the engine speed. Then adjust the needle valve carefully, first to limit the amount of gasoline supplied, noting the effect on the operation of the engine. Continue until the speed begins to fall off, and then turn the other way until the smoothest possible running is obtained.

Now close the throttle, and advance the spark quarter way. The engine should run evenly and

at low speed, well throttled down. The speed can be regulated by resetting the stop screw on the throttle lever.

If the engine shows a tendency to backfire or "pop" in the carburetor when the throttle is opened quickly, it is evidence of a lean mixture, which should be corrected by opening the needle valve very slightly until this tendency is no longer apparent.

If the engine is hard to start and will not idle, or knocks as if afflicted with carbon or spark knock when the throttle is opened quickly, it is further evidence of lean mixture and should be corrected by opening the needle valve adjustment slightly. Rich mixture will make itself apparent by the presence of black smoke issuing from the exhaust, which is characterized by a pungent odor, unmistakable to the trained engine operator. Blue smoke, on the other hand, has nothing whatever to do with the carburetor adjustment, resulting solely from an overabundance of lubricating oil. Likewise a white haze issuing from the exhaust, in the case of a kerosene-burning engine, indicates that the supply of water through the injector is slightly too much for the amount of fuel being burned and the load being carried, and the water supply should be cut down slightly.

Further evidence of a rich mixture is sluggish action of the engine, which sometimes is accompanied by a heavy pound which is quite irregular and which, therefore, can readily be distinguished from a bearing knock; and by a marked tendency for the engine to overheat, causing boiling away of the cooling water. The best way to verify the conclusion that the mixture is over-rich is to turn off the fuel with the throttle set to produce an engine speed slightly under the governed

speed of the engine; if the engine picks up speed after a minute or two, due to lowering of the fuel level in the carburetor and consequent weakening of the mixture, it is evident that the mixture has been too rich, and correction should be made by closing the needle valve slightly to provide good operation as outlined in the tests above.

Repairs.—If it is found impossible to obtain a satisfactory setting of the carburetor, it is likely that the device is out of order and in need of some slight repairs. The first thing to look for is correctness of the fuel level. In most tractor carburetors the fuel level is correct when the fuel just rises enough

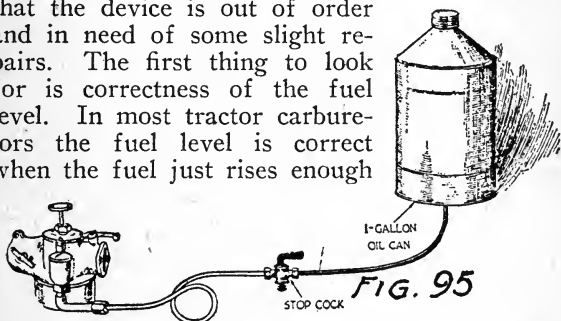

Fig. 95. Simple means of determining the correct adjustment of the float in the carburetor.

to overflow the shoulder surrounding the nozzle in the mixing chamber so that the well is full of fuel for starting. If the level does not reach this point, hard starting and the inability of the engine to idle will be the result due to weak mixture. The float lever should be bent very slightly and the carburetor tested to see if the correct level has been attained; this may have to be repeated several times in order to effect a cure. Figure 95 shows a hook up for testing the level.

If the fuel level is much above this point, we will have a sluggish engine due to rich mixture. It may be caused either by wear of the gasoline

inlet valve pin or its seat, causing leakage, so that the operation of the float does not stop the flow of gasoline into the carburetor bowl. The correction is to fit new valve needle and seat and so adjust with the float as to permit of the correct fuel level being attained. A bit of dirt on the valve seat will have the same effect. The float may have become "water-logged"; that is, it may have absorbed so much of the fuel that it has lost some of its buoyancy and will no longer close the valve fully. In this case replacement with a new float affords the best cure, and care should be taken to see to it that the float is coated with shellac varnish (except where alcohol is used as fuel) to protect it from the action of the fuel causing a repetition of the trouble.

The adjustment of the float operating lever may be such that it does not close the needle valve quickly enough so that a higher level than correct is attained. Correction is made by bending the lever away from the float slightly to permit earlier closing of the needle valve.

The carburetor may have dirt or grit in it which will stop up the jet or nozzle, retarding the fuel flow, or it may have a drop or two of water, which will have the same effect. In this case it is well to take the carburetor off and clean it thoroughly. Then remove the gas line from the tank and blow through it to clean out thoroughly, making sure at the same time that the sediment bulb is clean and free from water. To prevent recurrence of the trouble, drain a teacupful of gasoline from the sediment bulb on the tank frequently to prevent dirt from reaching the carburetor, and at least once a week drain the carburetor by means of drain cock provided on bottom of the bowl; this will wash it out

thoroughly and eliminate any sediment or water which has escaped through the sediment bulb and strainer provided on the bottom of the fuel tank.

Wear of the needle valve and its seat will result in a condition where it is no longer possible to obtain a correct carburetor adjustment. In such a case, the proper thing to do is to replace the worn parts with new ones. Likewise wear of the throttle disc will prevent idling of the engine unless the mixture is altogether too rich for good operation under full load conditions. The disc clearance should be about .008 of an inch with the disc closed; if it is appreciably more than that, replace it with a new disc. The clearance of the throttle spindle should be no more than .005 of an inch; where it is greater it will permit of air leaking in to thin the mixture, producing irregular operation and inability to throttle the engine down. This is also the case if any of the joints of the intake manifold or intake piping are not tight; there are several of them in some instances. In most cases they are made tight with copper asbestos gaskets.

To detect leakage at these points, start the engine and have it running with the throttle closed as far as possible. Squirt lubricating oil from a hand oil can around the joint. In case of leakage, the oil will be sucked into the manifold at the place where such leakage occurs. Correction can be made by tightening the hold-down nuts by means of which the manifolds are held in place, or in the case of a bad leak, by replacing the gaskets with new ones and setting the hold-down nuts up tight.

Doubtless it will prove helpful to the operator, regardless of the make of machine, to digest the following complete instructions for the care of the fuel system, which have been prepared

to cover the Twin City line, which is one of many equipped with the Bennett carburetor:

Fuel from the small gasoline tank flows to the carburetor by gravity.

Fuel after being placed in the main supply tank is pumped from there to the overflow cup, above the motor, and flows from the cup to the motor by gravity. After switching to the main supply tank, if the pump does not bring fuel to the overflow cup, look for the following causes:

Empty supply tank.

Leak in pipe between pump and tank.

Dirt under check valves.

Pump needs repacking.

A fuel strainer is placed in the pipe line where it joins the carburetor. This should be opened occasionally and the dirt, if any, removed.

There are two check valves located in the line leading from the fuel tank to the pump, and in case of trouble these should be examined.

If the pump gradually fails to pump and discharges a stream of bubbles into the overflow cup, it indicates that there is a leak in the pipe line between the pump and the tank, or that the tank is empty.

Leaks in the pipe line are easily caused by fittings working loose, and in such a case they should be unscrewed and the threads covered with shellac or common laundry soap; then re-assemble. Care should be taken not to strain valves or checks in screwing them together.

In case the pump is not working tighten the gland which forces the packing around the plunger. Never use any sticky or gritty material for packing. Drop a little lubricating oil around the plunger after the gland is tightened. Do not force this gland too tight or it will bind the plunger and break the pump from its fastenings.

If the fuel leaks around the pump plunger, the pump should be repacked. In placing the new packing, unscrew the cap, lift the gland out of the pump barrel and remove all the old packing, replacing it with new. Common laundry soap is a good lubricant for this purpose, and it is well to mix a little of it with the new packing. After replacing the gland, screw the cap down fairly tight; then loosen it until you are sure the pump plunger works freely.

A good method of packing the pump is to make two rings of No. 315 3/16-inch Anchor brand braided packing and place in the packing space and fill up the rest with lamp-wicking.

The fuel supply must be kept clean. If the pump suddenly starts and then stops pumping, it indicates that there is dirt coming through the check valves. Any dirt that happens to get into the fuel tank is liable to be drawn up into the check valves or carburetor and cause trouble. To prevent dirt or water from getting into the fuel, it should be filtered through chamois skin, or, in any case, should be strained through a fine screen.

If there is plenty of fuel in the overflow cup and the engine misses, first throwing out black smoke when the needle valve is opened far enough so that it will run at all, and then popping back through the carburetor, and no adjustment of the fuel valve will stop it, the indications are that there is dirt in the pipe leading from the overflow cups to carburetor, which has clogged the needle valve or supply pipe, so that the fuel does not flow into the carburetor fast enough to keep up the supply. Dirt may also lodge in the carburetor float valve. This usually causes the carburetor to overflow and drip from the bottom. The only remedy for this

is to take the pipes and carburetor apart and clean them.

If the exhaust has a weak muffled sound, and shows black smoke, too much fuel is being fed through the carburetor. If it back-fires or coughs back through the carburetor, the mixture is not rich enough and needs more fuel.

To adjust the enclosed type Bennett carburetor (Fig. 96). Turn fuel needle "A" clockwise as far as possible, and then unscrew about one full turn. Start motor, and by screwing air valve "B" clockwise, let as much air in as possible without making the

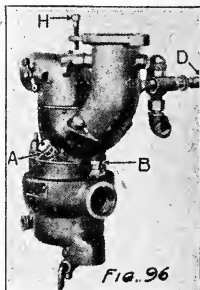

Fig. 96. Shows the enclosed type of Bennett carburetor as used on the Twin City $4\frac{3}{4} \times 7$ motors.

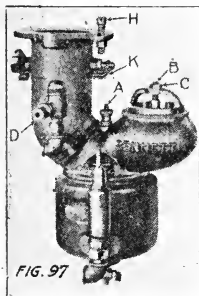

Fig. 97. Shows the open type as used on all Twin City motors except the $4\frac{3}{4} \times 7$ size.

motor miss or backfire. Do not open water needle "D" unless engine is using kerosene.

To adjust the open type Bennett carburetor (Fig. 97). Open fuel needle two full turns, and when motor is running cut down to $1\frac{1}{2}$ turns. It will not be necessary to touch the air valve, but in case the motor smokes too much and the fuel is cut down to good running, loosen nut "C" and use a screwdriver to turn screw "B"

clockwise. This will supply more air.

It may be necessary to give a little more fuel, but for best economy the carburetor should be

adjusted to use as little fuel and as much air as possible.

TO USE KEROSENE AS FUEL.

There are two fuel tanks used in the operation of Twin City Motors.

One is a small tank for gasoline, mounted higher than the motor from which the fuel flows by gravity to the carburetor, and the other is a large tank from which the fuel is pumped to a glass overflow cup and thence flows to the carburetor by gravity.

The engine must be started on gasoline. After the bowl of the carburetor is hot, shut off the gasoline and turn kerosene into the carburetor.

After the kerosene starts into the engine, it will sputter and choke, and the fuel needle valve will have to be opened one-quarter turn on the open type, and one full turn on the enclosed type.

After the engine runs a little there may be heard a metallic knocking or pounding, which is caused by preignition. In order to eliminate this the water injector valve should be opened and a little water sprayed into the intake pipe. This will cut down the heat, and the knocking will cease.

It will be necessary to retard the spark from that used for gasoline.

The engine will operate best on kerosene when the least possible water is injected. Just keep the adjustment so that the engine will not knock.

It is advisable to shift the carburetor back on to gasoline when the motor is idle a great deal, as the bowl of the carburetor will not continue to be hot unless some load is kept on the engine.

Caution.—Be sure and turn off water valve when engine is not running.

It is a good plan to shut off both fuel pipes,

drain carburetor, and leave drain open when the engine is not running, as this gives the float a chance to dry out and prevents water getting into the fuel, if the water valve should be left or leaks.

The hot air jacket around the bowl of the carburetor must be kept clean, as the successful operation of the carburetor depends upon this.

ALCOHOL.

The use of alcohol as a fuel for the internal combustion engines is very clean and no carbon whatever is caused from it. If a carbon deposit forms in the combustion chamber, it is from using too much lubricating oil and not from the alcohol.

All that is necessary to equip Twin City motors to burn alcohol, is to raise the compression of the motor by putting in longer pistons, and to replace the carburetor float with another which has a specially prepared coating instead of the shellac.

Gasoline is used to start the motor, but after the bowl of the carburetor is warmed up, alcohol can be used.

From eight to nine per cent more power can be obtained with alcohol than with gasoline, although about eleven per cent more alcohol will be used than kerosene, and thirty-eight per cent more than gasoline, for the same load. That is, it will take 4.8 gallons of gasoline, 6 gallons of kerosene or 6.7 gallons of alcohol for the same time and load.

The better the grade of alcohol, the less it will take and the economy in the use of one grade over the other will be all the way up to ten per cent.

The gravity of a good grade of denatured alcohol is .809, which is $7\frac{3}{4}$ pounds to the gallon, about the same as kerosene.

NAPHTHA.

Naphtha is used in the same way as kerosene, but the amount used will be a little more than gasoline and a little less than kerosene for the same load,—that is, 4.8 gallons of gasoline, 5.18 gallons of naphtha or 6 gallons of kerosene for the same full load for the same unit of time.

A COMPARISON OF FUELS.

A comparison of fuel consumption of various fuels, when the engine is working under full load, is given in the table below, taking gasoline as 1.

	Gals.	Specific Gravity
Gasoline	1.00	.7449
Naphtha	1.07	.7639
Kerosene	1.24	.8098
Alcohol	1.38	.809

INSTRUCTIONS FOR BURNING KEROSENE WITH CLAPPER VAPORIZER, USED ON BULL TRACTOR (FIGURE 98—A-B-C.)

Always start the motor on gasoline and adjust the needle valve in carburetor to handle the full load as though you intended to run on gasoline, and as soon as the vaporizer chamber is warmed from the exhaust, switch from gasoline to kerosene. There is no other adjustment necessary. In working the motor to its maximum capacity, it may be necessary to open the needle valve in carburetor about one-quarter turn, which you would necessarily have to do with gasoline.

With the use of kerosene in extreme loads, or when there is a "metallic click" in cylinder, use a small amount of water, the amount vary-

CLAPPER KEROSENE VAPORIZER.

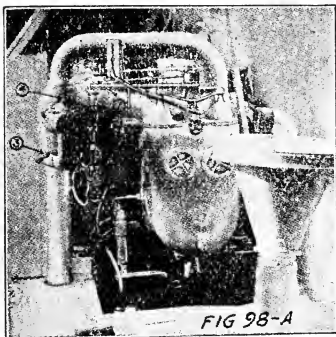

Plate No. 1.

- No. 1—Water spray valve.
 No. 2—3-way valve.
 No. 3—Carburetor drain.
 No. 4—Carburetor needle valve.
 Single adjustment for kerosene the same as gasoline.

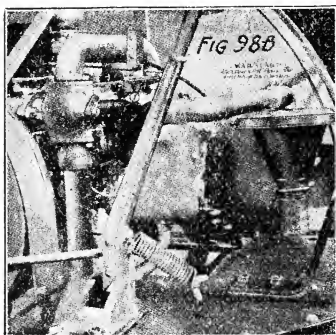

Plate No. 2.

Side view of Clapper Kerosene Vaporizer showing simplicity of construction. Positively no moving parts. Unquestionably the greatest improvement of the age for the successful burning of kerosene.

If motor stops when burning kerosene and stands for any length of time, switch 3-way valve on to gasoline and open pet-cock (No. 3, Plate 1) to drain off the kerosene. Prime cylinders before again trying to start.

Operate tractor under load at least five minutes before attempting to switch to kerosene.

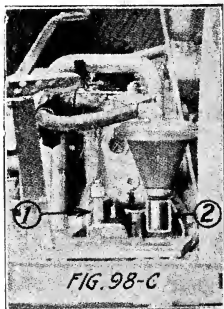

Plate No. 3.

Always keep glass jar in place. Empty out-as often as necessary (No. 2, Plate 3).

To fill oil reservoir, remove plug in filling pipe (No. 1 in Plate 3). Fill to within three inches of top. Be sure to screw plug in tight to avoid sucking air.

ing to the load. When running idle or you stop the motor, always shut off the water. It is advisable to shut off the kerosene line before you stop the motor to allow the carburetor to fill up with gasoline ready for starting again.

You will get more power and better results with a retarding spark on kerosene than gasoline, due to the perfect vapor and more heat units—simply pull magneto spark control rod back until, from the sound and power developed, you have the proper range for igniting the charge.

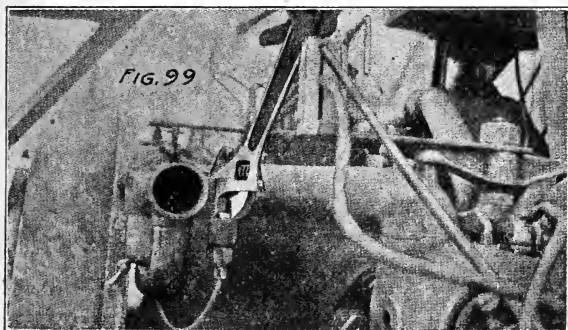

Fig. 99. Adjusting leaky carburetor.

A leaky carburetor is the result of dirt in the inlet valve, preventing the float needle from seating properly.

To remove this, remove plug from over the float needle (Fig. 99) and work the needle in the inlet valve up and down several times, pressing it to its seat each time and turning it. This will remove any foreign matter that may have gathered there and allow the float needle to seat itself.

If this does not stop the leak, float is too high and should be set lower.

Once a season, the float should have a coat of shellac. It will take but a moment, as it dries very rapidly. (Have float dry before putting on shellac.)

There may be sediment in the bottom of the bowl of the carburetor. Remove the bowl and clean it out.

One of the most important points in connection with the operation of the tractor engine is to keep grit and dust from reaching the bearing surfaces, such, for instance, as the cylinder walls, main and connecting rod bearings, etc. It is obvious that any dirt carried in through the air inlet on the carburetor will be brought into direct contact with the cylinder walls, which are, of course, covered with a layer of oil sufficiently "tacky" to catch the grit and hold it. Rapid wear of the wall surfaces can, therefore, be expected.

But more than this—the oil from the cylinder walls is carried down, in part, by the downward movement of the piston and a generous measure of the grit reaches the crankcase chamber where, in the case of the engine equipped with a circulating lubricating system, it will enter the oil supply to be circulated, and recirculated, to the engine bearing surfaces.

It is only to be expected, therefore, that an engine not protected in the best possible manner from the entrance of grit, as above pointed out, will wear out more quickly and give far greater trouble, calling for frequent repairs, than one adequately protected from such dust. There are very few tractors now on the market, therefore, on which the engines are not equipped with some device for freeing the air entering the carburetor from contamination so that nothing but pure, clear air is taken into the cylinders.

These air filters or air washers, as they are variously called, are built to operate on three distinct principles. The simplest is nothing more nor less than a filter, all the air entering the cylinder being caused to pass first through a filtering medium such as a piece of felt cloth by means of which the dust is eliminated. Perhaps the best-known device of this sort is the Orem motor protector, in which the filtering felt is stretched over the surface of a wire netting cylinder from the interior of which air for the carburetor supply is drawn; all the air reaching the interior must pass through the cloth.

It is evident that strangulation of the air, or any impediment to its free entry into the carburetor, will result in a falling off in power; as the filter cloth does offer some resistance, its area must be made sufficient to cut this resistance to a minimum. In the Orem device, this area has been figured with relation to the amount of air a given engine will handle in a minute, under full load operation.

Furthermore, unless some means were taken to prevent such action, after a few moments of operation under extreme dust conditions, the filter cloth would become so clogged as to partially strangle the air passage. In the Orem device this is prevented by the simple expedient of setting the cylinder upright, or in a vertical position, whereby the vibration of the engine itself is employed to cause the dust to drop off the outside surface of the filter cloth into a collecting funnel, from which it can be emptied from time to time as occasion demands. The device also serves as a regulator for the temperature of the incoming air. This is effected by connecting the outer cylinder to the air stove on the exhaust pipe whereby heated air is brought

to the device. A regulating shutter is provided, however, so that cold air can be introduced to bring down the temperature of this air during the hot summer months when particularly high heat is not required.

The second type separates the dust from the air on the centrifugal principle. The entering air is caused to take up a very rapid swirling or rotary motion by the form of the passageway into the cleaner; due to their great weight in comparison with the weight of the air itself, the dust particles are thrown to the outer wall of the case, where they are caused to settle out by gravity. The well-cleansed air is drawn from the center of the device, a point which the heavy dust particles cannot reach because of the effect of the centrifugal force acting on them due to their rapid circular motion.

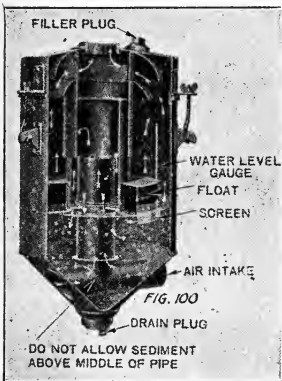

Fig. 100. A typical tractor air washer.

By far the most popular type of cleaner, however, is the air washer, one of which is shown in the accompanying illustration (Fig. 100). In this type all the entering air is caused to bubble up through a quantity of water, which collects the dust and dirt and leaves the air absolutely clean. Perhaps the effectiveness of the device as an air cleaner is only partially responsible for the popularity of the air washer; the other big point in its favor is the fact that it humidifies the enter-

ing air and acts, to a certain extent, to smooth out the action of the engine and eliminate the formation of carbon deposit.

A sectional view of a typical air washer such as is fitted to the popular Case tractor is given in Figure 100. It comprises a cylindrical vessel partially filled with water, the level being indicated by a glass sight on one side of the casing. The air enters through a central pipe running about half way up into the chamber; but the air finds itself, not in the housing, but in a smaller inverted cylinder placed over the air intake pipe. This second or inner chamber is attached to a metal float which rises and falls with the water level in the air washer, and the only passage for the air out of the chamber is past the bottom of the inverted cup, over the lower surface of the float and up along the sides. The top of the air washer housing is attached to the carburetor air intake, so that immediately the engine is turned over, some of the air is exhausted, and we have a partial vacuum formed sufficient to cause the air to bubble through the water, finding its way from the inner to the outer compartment; and in passing through the water it is freed of its dust and dirt.

The arrangement of the inner chamber on a float is a very simple means of insuring that the air must pass through a given depth of water, regardless of the quantity of water in the air washer. In other words, provided that the water level is maintained so that it can be seen through the sight gauge, the suction necessary to draw the air through the air washer will always be the same. The level of the water cannot be brought too high, for if it should be brought above the air intake pipe, it simply will overflow and run off; it should never be allowed to evap-

orate to a point where the level cannot be seen in the sight gauge, however, as then the desirable features of the device are impaired and dirt will be carried into the engine cylinders.

It is well to remove the drain plug from the bottom of the device frequently and wash out the sediment that has collected. The best plan is to fill the washer to capacity with clean water every day, making sure that the water filler plug on top of the device is replaced tightly. If the plug is not replaced, the washer might just as well be off the engine for all the good it will do.

In the case of the dry types of air cleaners, it is well to bear in mind that cleaning the sediment trap should never be attempted with the engine running. To do so means that the dirt stirred up in the process will be drawn in large quantities into the cylinders to the detriment of the engine.

CHAPTER VI.

Lubrication of the Engine.

Why One Oil Will Not Do for All Types. Factors Affecting the Oil Used.

BETWEEN tractor success and tractor failure; between a farm power machine which runs well and delivers its power smoothly, economically and reliably and one which is spasmodic in its performance, unable to stand up to its work, unreliable and troublesome, there lies a very narrow chasm—a film of oil perhaps .003 of an inch in thickness, sometimes more and oftentimes considerably less.

This oil film, quite regardless of the amount of work or kind of work the tractor is called upon to do, regardless also of temperature conditions both inside and outside the engine; and notwithstanding other operative conditions which may tend, at times, to destroy it, must be maintained religiously. Even momentary failure of the oil film at any one of a score of vital points in the power plant will mean: first, loss of power output and irregular operation; second, and even more annoying, excessive wear; eventual breakdown and stoppage; troublesome and costly repairs.

Broadly speaking, the oil film serves the same purpose in a plain bearing as do the steel balls in the ball-type anti-friction bearing. It separates the rubbing surfaces, keeping them out of actual metallic contact and replaces the rubbing friction, which otherwise would be set up between the metal surfaces in contact, with greatly lessened friction between the liquid particles

themselves and between the liquid particles and the metallic surfaces of the bearings, just as in the ball or roller bearing the greatly lessened rolling friction between the balls or rollers and the raceways is substituted for the rubbing friction of the plain bearing surfaces.

Points in the engine (Figure 101) at which it

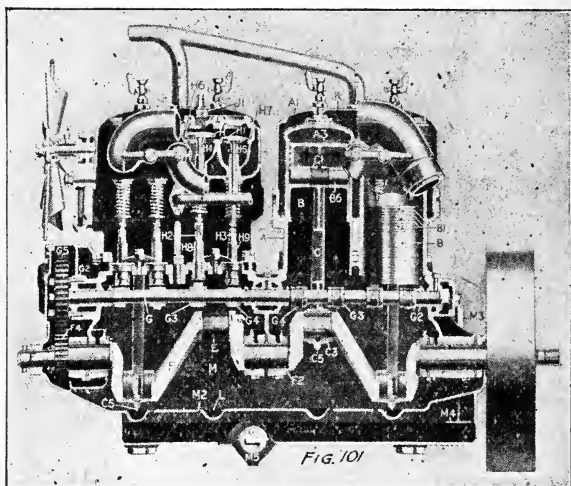

Fig. 101. Section through typical tractor engine, showing points where oil is necessary.

is essential that this oil film be maintained for the purpose of reducing friction, and the power loss and wear which it entails, are the mainshaft, crankpin, piston pin and camshaft bearings; the cylinder walls for lubrication of the cylinders themselves, the pistons and piston rings; the cams, cam followers and cam follower guides; the timing gear mesh and, where used, the timing gear idler wheel bearing.

Wholly aside from its function of reducing sliding friction between the piston and the cylinder wall, the oil film on the latter performs another and a highly important service. Expanding packing rings, called piston rings, are fitted to the pistons as a means of filling the clearance space which must be left between the piston and cylinder walls in order to provide room for excess expansion of the piston over and above the increase in diameter of the cylinder bore due to the fact that the piston operates normally at considerably higher temperature than the cylinder walls.

This will readily be appreciated when it is considered that the cylinder walls themselves are directly cooled by the water circulating system, whereas the head of the piston is cooled only by means of heat being conducted to the piston skirt and transferred from that point through the oil film to the cylinder walls for absorption by the cooling medium. These rings, which are applied to the piston, must be so fitted as to leave a working clearance in the ring slot; were this not the case they would be likely to stick in the ring slot, preventing their expansion against the cylinder walls and thereby defeating their own purpose.

Rings, for the most part, are eccentric in form; that is, the outer or bearing surface is not struck from the same center as the inner circle. The slot or joint is formed at the thinnest portion of this eccentric ring, this for the purpose of providing approximately uniform tension against the cylinder walls at every point on the ring circle. A moment's thought will make it evident that since the ring slot provided in the piston for the reception of the ring is of uniform depth, while the ring itself is of tapering form, there is

going to be a cavity or pocket between the bottom of the ring slot and the ring itself at its narrower portions.

This fact taken into consideration with the clearance left for free movement of the ring in its slot, makes it possible for the highly compressed gases above the piston to work through this clearance, in behind the ring, and then out again at the bottom, escaping to the crankcase chamber.

The second purpose of the lubricant on the cylinder walls, then, is quite obvious. It must serve to set up an oil seal adapted to fill this clearance and prevent the gases from working in behind the piston ring and making good their escape. And by the way it performs this second function, taking into consideration also its efficiency as a lubricant, so is an oil judged proper or improper for tractor engine use.

Any oil, to be of service either as a lubricant or to maintain this desired piston ring seal, must be capable of thorough and even distribution to every point in the engine where a lubricant is required through the system of distribution provided by the engine designer. In determining the proper lubricant for the engine, therefore, our first consideration will be an analysis of the system of lubrication employed.

Speaking generally, all tractor engine lubricating systems can be classified under five separate distinct headings. Perhaps the simplest is the plain splash system illustrated in Figure 102. In this system the fresh oil is contained in a reservoir absolutely distinct and separate from the crankcase and is fed to the crankcase in exactly the proper amount to maintain a constant level in the crankcase itself. The oil feed is accomplished by means of a plunger pump which is ad-

justable, as to plunger stroke, so that the oil feed can be adjusted to meet the operating conditions.

Oil dippers or splashers on the lower ends of the connecting rods dip into the oil and splash the lubricant up in the form of a fine spray, projecting it to the cylinder walls for the lubrication of the cylinders, pistons and piston rings and to wells provided over the mainshaft, camshaft and piston pin bearings, and in most instances to a well under the mainshaft timing gear. Some of the spray is projected to the cams themselves, the cam followers, and in some cases to the valve stems for their lubrication.

Two methods are employed for conducting the oil into the crankpin bearings; the more usual

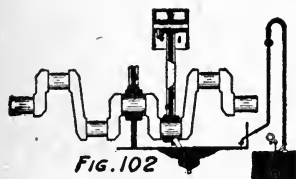

Fig. 102. Splash system.

is to drill through the connecting rod bearing cap just in front of the splasher, so that the impact of the rod with the oil drives the oil into the bearing; the less usual method is to drill

and counterbore two small holes in the connecting rod bearing upper half at each side of the rod proper by means of which a quantity of oil is enabled to reach the crankpin bearing.

This system is known as the "all loss system," for the reason that none of the oil, after use, is returned to the reservoir; all the oil pumped into the crankcase is either used or thrown off by the action of the engine.

In order to provide efficient and even distribution of the oil throughout the crankcase chamber, insuring a copious supply to every bearing and rubbing surface, it is essential that the oil splashed by the connecting rod dip be

thoroughly atomized or broken up into a form where it is readily carried or floated on the trapped air to the parts requiring lubrication. An oil of proper body to lend itself readily to such thorough atomization, therefore, is a prime requisite with any system where the connecting rod dip or splash is relied upon for the oil distribution within the engine itself. Such an oil must be of medium or light body. An oil too heavy in body will not be so finely divided under the connecting rod impact and this condition is particularly emphasized under winter conditions when any oil shows a tendency to thicken up or to increase in viscosity.

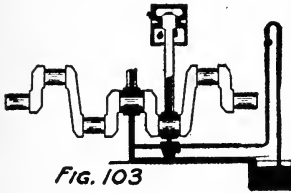

Fig. 103

Fig. 103. Splash circulating system.

Another point in connection with the "all loss" system is fact that the oil in the crankcase is constantly being built up, as to body and quality, by the addition of the

fresh oil supplied by the pump or mechanical oiler, as the case may be. Obviously, therefore, an oil of lighter body can be used more effectively than is the case where the whole oil reserve is circulated and contaminated by the admixture of fuel and carbon sediment.

The second lubricating system is the splash circulating system illustrated in Figure 103. In this system the bottom of the crankcase forms an oil reservoir from which the oil is pumped, usually by a gear pump and less frequently by a plunger pump or the centrifugal action of the engine flywheel, either to dipper troughs, located one under each connecting rod, or to open wells over the mainshaft bearings from which the

overflowing oil supplies the dipper troughs. Suitably placed orifices in the dipper troughs serve to maintain the oil level constant so that the connecting rod dip is always the same.

It will be seen that in this instance it is not essential that the quantity of oil supplied by the pump be regulated to coincide with that used in the lubrication of the engine. As a matter of fact, the flow is always considerably in excess of what the engine is using, and this excess overflows from the dipper troughs back to the reservoir for re-circulation by the pump. The cylinder walls, pistons and piston rings and all the

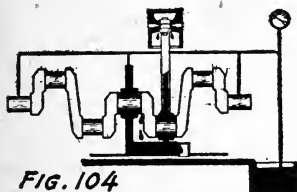

FIG. 104

Fig. 104. Force feed and splash system.

various bearing surfaces are lubricated by the connecting rod splash exactly as with the plain splash system.

Obviously, in order to provide for thorough atomization of the oil and consequent

thorough and even distribution, an oil of light or medium body should be used. On the other hand, due to the fact that the oil is constantly being circulated and subjected to wear and tear in the engine itself, as a result of its usage and re-usage, in order to provide maximum lubrication an oil of heavier body is required than with the splash, "all loss" system. The splash circulating system by its nature is best adapted for handling a medium bodied oil.

Third in line comes the force feed and splash system illustrated in Figure 104. Here we have the oil contained in a crankcase reservoir exactly as with the splash circulating system, and forced by a gear or plunger pump to each of the main-

shaft bearings under pressure, and in some instances also to the camshaft bearings. As a rule, in order to maintain the pressure approximately constant regardless of variations in engine speed, a safety valve or by-pass is placed in the oil header and set to permit any excess oil delivered by the pump to be projected onto the timing-gear train for lubrication of these gears.

The oil bleed from the mainshaft bearings serves to maintain a constant level in the dipper troughs which, as with the splash circulating system, are equipped with properly placed overflow orifices so that too high a level cannot be reached. With the exception of the mainshaft bearings—rarely the camshaft bearings—and the timing-

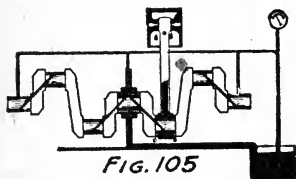

FIG. 105

Fig. 105. Force feed system.

gear train, the distribution of the lubricant to the various surfaces is exactly the same as with the splash circulating system. The conditions encountered in this system being so nearly identical with those on the splash circulating system, it is evident that this system also will operate at its best when a medium bodied lubricant is employed.

In the fourth system of lubrication the connecting rod splash is done away with. It is called the force feed system and is illustrated in Figure 105. As with the force feed and splash system, the oil is fed by pump pressure to each of the mainshaft bearings and sometimes to the camshaft bearings. An oil by-pass is incorporated in the system to maintain the pressure approximately constant. From the mainshaft bearings the oil is conducted either through drill-

ings in the crank-webs or through the hollow crankshaft to the crankpin bearings under pump pressure.

The oil bleed from the crankpin bearings is projected in the form of a very fine spray to the cylinder walls for the lubrication of the cylinders, piston and piston rings; and to the piston pin bearings, the cams, the cam followers and, in some cases, to the camshaft bearings, where these are not taken care of under pressure. The excess oil, draining back from the crankcase chamber walls, reaches the reservoir and is re-circulated by the pump.

Here we have a condition where the more important bearings are

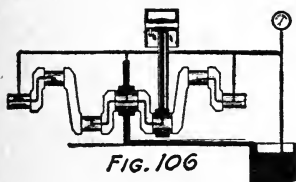

Fig. 106. Full force feed system.

important bearings are fed directly under pressure from the pump; it is also apparent that since the oil spray results from the oil being projected through the very small annular passage on either side

of the crankpin bearing under pump pressure, augmented by centrifugal force, we have a positive means of finely dividing or atomizing the oil so that the use of a heavier lubricant than that best adapted for splash distribution, is made possible. The force feed system, where the oil pump is submerged in the reservoir so that there will be no question as to the pump drawing a full supply when the engine is started and the oil is chilled, is preeminently adapted to handle medium heavy-bodied and heavy-bodied oils.

There is not a great deal of difference between the force feed lubrication system and the full force feed system (Figure 106.) The pressure

line is carried one step further and the oil is led up from the crankpin bearings to the piston pin bearings by means of an oil pipe attached to the side of the connecting rod, so that the piston pin bearing is also fed under pressure. The oil bleed from the crankpin bearings, however, is relied on for the lubrication of the cylinder walls, pistons and piston rings, cams; generally also the camshaft bearings and the cam followers. A by-pass and oil pressure regulator, as a rule, takes care

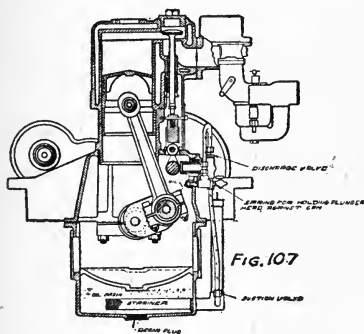

FIG. 107. Splash circulating system as applied to the All-Work tractor engine.

of the timing-gear lubrication. Obviously, the full force feed system is likewise adapted to the distribution of a heavy-bodied lubricant.

It was pointed out before that there are many little points of diversion in lubricating systems which would

seem, at first sight, to make them fall without bounds, so to speak, with regard to these five classifications. Take, for instance, the type wherein a mechanical oiler is used, the oil being forced to each of the bearings and to the cylinder walls under pressure. This can be classified as a force feed system in which a series of pumps—one for each oil lead, in fact—is substituted for the single pump used on the orthodox system. It is not a circulating system, however, since the oil is not returned to the reservoir. Such a system can be used for the distribution

of either heavy, medium-bodied and light-bodied lubricants, but the necessity of using exposed oil leads demands a lubricant of sufficient fluidity for efficient distribution under winter temperatures.

It must be considered that the details in the arrangement of these systems will greatly affect the choice of the lubricant as to body. For instance, as was pointed out before, an oil pump submerged in the lubricant is better adapted to

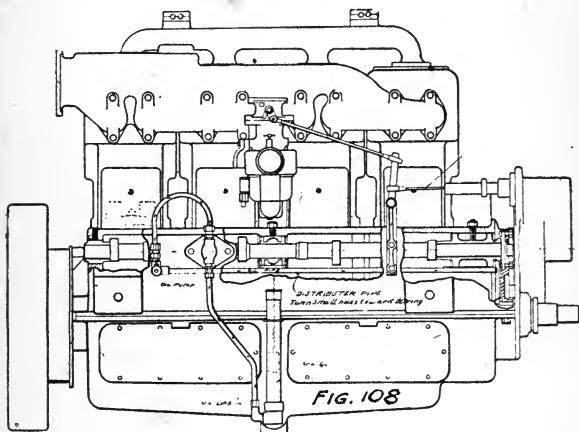

Fig. 108. Arrows show course oil takes from oil reservoir through the motor on All-Work tractor.

handle a heavier oil than an elevated pump; and this condition is greatly emphasized under winter temperatures. Likewise a submerged gear pump is better adapted to handle a congealed or thickened oil than a plunger pump, which depends on suction for its initial charge. On the other hand, an elevated plunger pump is better adapted to function properly, except at low temperatures, than an elevated gear pump, since the latter can-

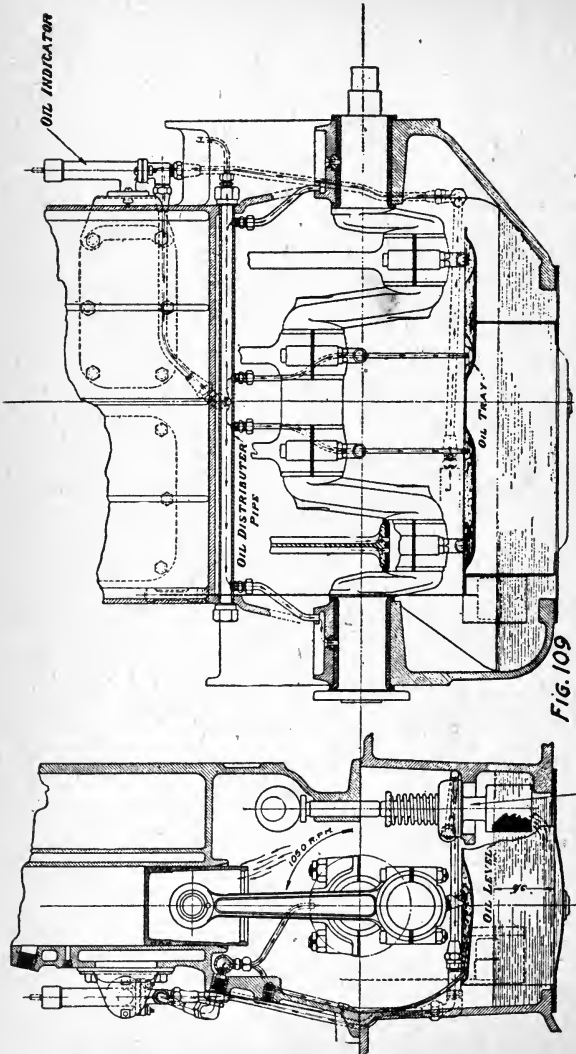

Fig. 109

Fig. 109. Engine lubrication on Case 10-18 tractor, splash circulating system.

not be packed tight enough to insure its being primed sufficiently after a stop of considerable duration, to circulate the oil immediately the engine is started.

Where conditions tending toward irregular pump action are encountered in the lubricating system, in order to insure that degree of positive action which is essential to correct motor performance and power production, we naturally are going to use a lighter grade of oil, which is easier to move, than the general analysis of the lubricating system as applied, would seem to call for.

Having analyzed the system of lubrication and determined from its general type, and from the details of its construction, which is the proper grade of oil for use with it, our next step will be to analyze the engine construction with the view of determining whether the oil, as recommended, will properly perform its functions. For instance, not all tractor engine designers are of the same opinion as to piston material and piston clearance; nor are all of them sold on the eccentric piston ring as against the concentric type which eliminates, to a greater or less extent, the oil cavity or pocket behind the ring.

We will find, therefore, that one engine when cool will have a greater piston clearance than another, and while it is the object of every tractor engine designer to bring this clearance as close as is consistent with free piston movement and a high factor of safety against piston seizure, still even at normal operative temperatures we are going to find a great divergence in the amount of piston clearance between engines of different design and different manufacture.

Nor are all production methods identical. One manufacturer will produce his cylinders by

a double-rough-cut-and-ream finished method, whereas another will produce a fine cylinder wall finish by the grinding method.

The oil, as determined, must be of a grade which not only will lend itself to perfect distribution through the oiling system, but will also maintain the proper piston ring seal at normal operative temperatures with mechanical clearances as encountered in the particular engine under consideration.

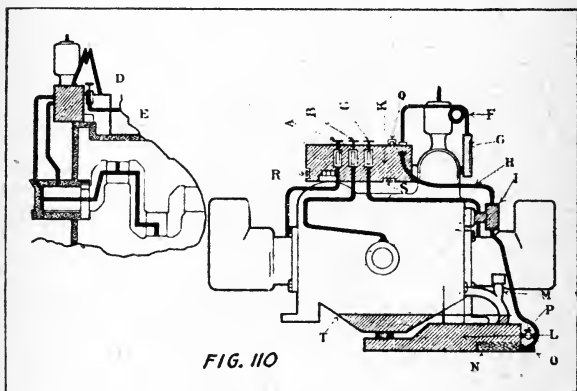

FIG. 110

Fig. 110. The Big Bull force feed circulating oiling system forces the oil through a hollow crank shaft and delivers it to the inside of the connecting rod bearings. Reduces the amount of oil used and is a positive feed, so long as there is oil in the reservoir. The operator can see the oil flow all the time from his seat.

Considering the bad effects of non-maintenance of this piston ring seal, let us assume that we have the engine with one of the pistons up nearly at the top of its compression stroke. Above the piston we have, then, a more or less wet mixture of gasoline and kerosene vapor and air compressed to approximately 60 pounds per

square inch, depending on the compression ratio of the engine and the position of the crankpin.

Since the piston ring seal is not being properly maintained, some of this wet mixture will work down past the pistons, "blow by" the rings and the gasoline or kerosene, either of which is a first-class solvent of the mineral lubricating oil, will wash the lubricant from the cylinder walls, further aggravating the situation, and paving the way for increased "blow-by" on the next compression stroke.

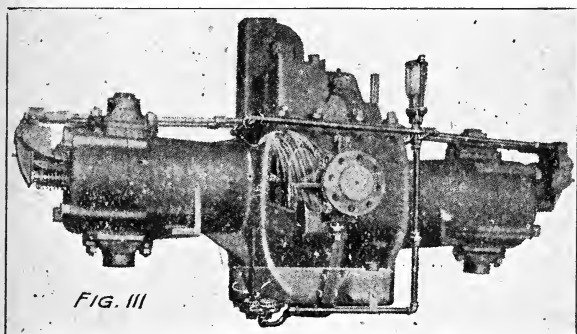

Fig. 111. Splash circulating system as modified by Avery.

In the meantime we have lost to the crankcase chamber from the combustion chamber a quantity of fuel—a certain portion of the heat units which we were counting on to develop full power from the engine. More than that, we have reduced the compression, due to this loss, and since the power that the internal combustion engine is capable of developing is dependent almost directly upon the compression pressure, within limits, we have in this another source of reduced power output or loss in efficiency. Still a third

source is the lack of effective lubricant on the cylinder walls, which increases the piston friction, causing a power loss and a tendency to overheat, as well as a tendency for rapid wear of the pistons, piston rings and the cylinder walls.

Let us neglect for a moment the amount of mixture which has escaped down into the crankcase chamber, and let us consider that we have turned the engine over past its top dead center and that it is now on its power stroke. We now have above the piston a quantity of intensely hot gases at very high pressure. The temperature

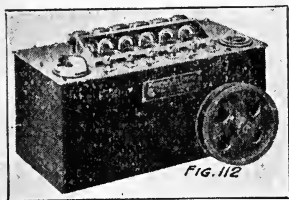

Fig. 112. Force-feed lubricator.

range will be between 2000° to 3000° F., while the pressure will be, roughly, four times the compression pressure, or somewhere in the neighborhood of 250 pounds per square inch. These gases are made up largely

of that inert constituent of the atmosphere—nitrogen—and of the products of combustion of the hydro-carbon fuel, which are carbon-dioxide, carbon-monoxide and water vapor. There will be traces of other gases, which we need not take into consideration.

The escape of these gases past the piston has two effects. One is, of course, to cause a reduction in working pressure on top of the piston—our real source of power—and consequently we have still another cause of power loss as a result of the breaking down of the piston ring seal. The second effect will be greatly to augment the temperature of the piston and cylinder walls, due to the passage of these intensely hot gases

through the clearance space. Here again we have a condition which tends to increase friction and reduce power output.

Let us now look into the crankcase chamber and see what has happened there. On the compression stroke we brought down a quantity of vaporized fuel, which quickly condensed in the crankcase chamber and mixed with the oil, reducing its body and impairing, to a greater or less extent, its lubricating efficiency. In aggravated cases, the body of the oil will fall off sufficiently to im-

pair seriously the lubrication of the engine bearings and we will have increased friction between all the moving surfaces and a tendency for the

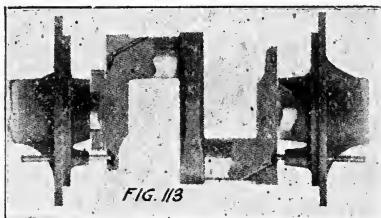

Fig. 113. Crank shaft, showing how the oil is carried to the bearings on Leader tractor engine.

b e a r i n g s t o r o u g h e n u p i n s e r v i c e .

On the power stroke the escaping gases carried down with them a quantity of water vapor which has also condensed in the cooler crankcase chamber; and being heavier than the oil it has been deposited at the bottom of the oil reservoir or else, due to favorable oil temperature conditions, has formed an emulsion with the oil. In the former case the water will naturally settle in the oil pump—usually the lowermost point in the reservoir—and in case of a cold snap will freeze up, locking the pump, resulting in a condition which will cause breakage of the oil pump-shaft if the engine is started without first being warmed up. In the second case, the mixture of

oil and water is not conducive to proper lubrication.

There is still another effect which we have not considered. Let us now turn the engine over until the piston is on the intake stroke. We then have reduced pressure in the combustion chamber above the piston and atmospheric pressure in the crankcase chamber, and since the oil is not of the character needed to maintain proper piston ring seal, we are going to get a "blow-by" in the other direction, and this upward "blow-by" is going to carry a quantity of the lubricant up into the combustion chamber where, being slow burning, it is going to tend to produce carbon deposit. This is a condition which must not be lost sight of.

It will be seen, therefore, that the condition as to piston clearance, and the ability of the lubricant to maintain an effective piston ring seal, is going to be second in importance in the determination of the proper grade of lubricant only to the system of lubrication itself. Other factors which must be taken into serious consideration are the normal operative temperatures of the engine; the cylinder arrangement, the valve arrangement; the engine speed; climatic conditions, etc.

It is a fact, however, that each of these factors is so interlinked and influenced by some or all of the others, that it takes an experienced automotive engineer, who is not only thoroughly grounded as to tractor engine design and practice, but who also has had broad practical experience with tractor operation in the field, to size up the situation as regards any particular engine and make an oil determination on a scientific basis. And at that, such a man must also be thoroughly equipped with a knowledge of the

characteristics as well as the character of the various grades of lubricating oils he has under consideration.

For the average tractor owner or operator to try and judge the quality and lubricating value of one oil as against another by so-called oil tests, which are, at best, mere guess-work as he applies them, is foolhardy. With lubricants, as with other commodities, quality counts, and quality cannot be obtained without careful attention to detail in process and procedure at the oil refinery; and this very carefulness, which is the tractor owner's safeguard as to lubricating value, means, of course, increased cost. It could not be otherwise.

Every reputable oil manufacturer maintains a corps of highly trained technicians, who make a sufficient number of both physical and chemical tests in a fully equipped laboratory and under conditions which assure the utmost in accuracy to determine uniformity of product and to eliminate even slight variations in the character of their products from day to day.

These tests, however, are by no means a measure of the lubricating value of an oil. The value of an oil as a lubricant depends, first, upon the stocks from which it is made and the process or processes employed in the refining of these stocks; and second, upon the process or processes employed in combining these stocks. Upon these two features alone depends the character of the lubricant and no tests which it is within the power of the average oil user to make can determine them.

The safest and best course for the tractor operator is to buy the best oil the market offers, quite regardless of the cost, and to use the particular grade of that oil for his tractor engine

which the oil manufacturer has specified for this purpose. If this plan is followed, the tractor owner will find that the recommendation offered him by the oil manufacturer has been determined only after careful analysis of his engine construction by a lubricating engineering staff, every member of which not only knows tractor engines from front to rear and also "crosswise," but also is thoroughly versed in what the lubricants, as recommended, will and will not do and the reasons therefor.

DETAILED CARE OF LUBRICATING SYSTEMS.

There is not a great deal that need be said with regard to the care of the lubricating systems which fall under the circulating classification. The principal point to bear in mind is to keep the reservoir well filled, as indicated by the level gauge, so as to be sure that the engine has plenty of oil.

For the benefit of readers in doubt as to which grade of oil to use, a chart is appended covering most tractors on the market at present. This chart has been carefully prepared by experienced lubrication engineers and the user will do well in following it to the letter. But in doing so, see to it that you obtain the best lubricant that the market affords; it is well worth the additional cost.

With circulating systems, frequent draining of the system and refilling with fresh oil is essential for the reason that there always will be a certain amount of fuel admixture which will impair the quality of the oil and its value as a lubricant; also a certain amount of sedimentation, particles of metal, carbon and grit drawn in through the breather pipe.

Where kerosene is used as fuel, the best plan is to drain the reservoir after every 25 hours of service, draining while the engine is still warm, so as to carry out the last trace of sediment.

Where the fuel is gasoline, once in 50 hours is generally sufficient for draining.

Do not flush out the crankcase with kerosene after draining, as some of the kerosene will be trapped in the dipper troughs or other basins in

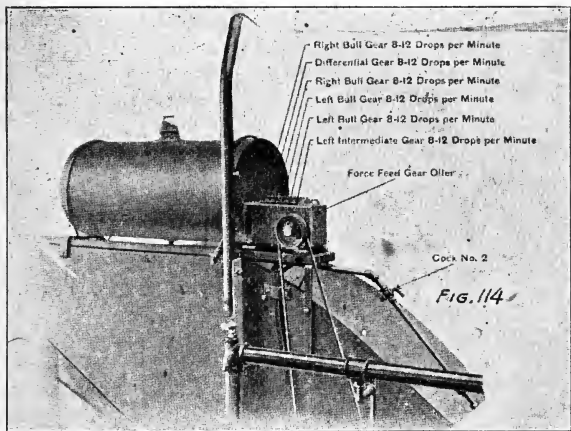

Fig. 114. Adjustment of mechanical oiler on the Aultman-Taylor tractor.

the engine and will remain to impair the quality of any fresh oil added. The best plan is to drain, wash out with a quart of fresh oil, and then refill the system with new oil.

When the oil pan can be removed from the bottom of the engine so that all points can be reached and mopped out, the system can safely be washed out with kerosene—not otherwise, however.

The care and adjustment of systems employing the force feed mechanical lubricator can be gathered from the following excerpts from manufacturers instruction books dealing with the subject:

DIRECTIONS FOR DETROIT FORCE-FEED OILER.
(Figure 115.)

Be sure the tank, or reservoir, is perfectly clean before filling with oil the first time. Any

foreign substance is apt to injure your engine's bearings.

Be sure to strain your oil before filling the tank—always.

To fill, unscrew the filler cap "A" and pour in the oil.

Amount of oil in tank is shown by the position of the pointer. If

it points to "EMP" the tank is empty; if it points to "FULL" the tank is full. Different levels are indicated by the different positions of the pointer.

Regulation of each feed is accomplished by adjusting the button "C" in front of that feed.

When the small stop or projection with the zero mark (0) on the bottom of "C" is against and on the right-hand side of the stop/pin so that the zero mark is in line with the mark "D" no oil is being fed.

To feed, turn the button to the left, or in a

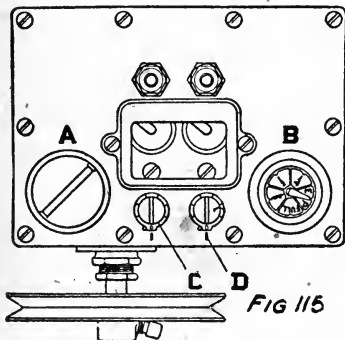

Fig. 115. Adjustments on Detroit oiler.

counter clockwise direction. One complete turn to the left opens the feed to full capacity.

To decrease the feed, turn to the right, or in a clockwise direction.

The regulating buttons are slotted for a screw-driver, coin or other flat piece of metal, as the adjustment is purposely made stiff.

Once the feeds are adjusted, no further regulation is necessary.

It is not necessary to turn off the feeds every time the engine stops. The force feed oiler starts and stops automatically with the engine.

To adjust the feed of oiler to your engine: Every engine is different from every other engine and no absolute rules can be laid down as to the exact quantity of oil required for your engine.

If your engine is new, pour about a quarter of a teacup of oil through the spark plug hole on each cylinder and turn the engine over by hand several times to be sure the cylinder and rings are thoroughly lubricated before starting. Pour oil in each crankcase, too.

The best way to do this is to feed plenty of oil at first. Take one feed at a time and very slowly and gradually cut down the amount of oil fed to the one bearing until you have found the least amount of oil that will give adequate and perfect lubrication. After one feed is adjusted, the others can be regulated in the same way.

Great care will have to be taken in this process not to feed so little oil that a bearing is burned out or a crankshaft, piston or cylinder scored. Overheating and squeaking are signs of too little lubricating oil being fed.

Blue smoke at the exhaust indicates too much

lubricating oil to the cylinder. Black smoke indicates too much gasoline.

ADJUSTING OILER ON BULL TRACTOR. (Figure 116.)

Do not close off feed valves on lubricator until the motor has run several days, and then with caution.

All inside parts of motor are lubricated with a six-way force-feed oiler.

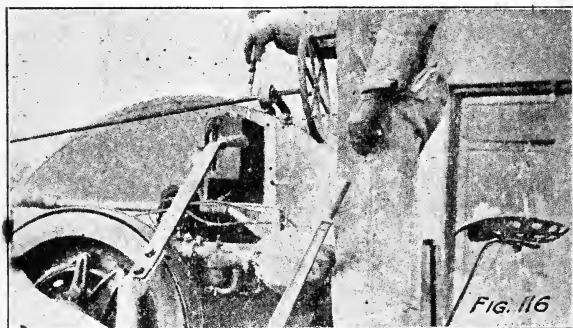

Fig. 116. Adjusting mechanical oiler.

Before starting motor, be sure this oiler is filled with good clean oil, and turn oiler by hand to see that it pumps freely.

Always keep oil in the crankcase up to level with drain cock on the flywheel side of crankcase, but never above the level.

After motor starts be sure that every pipe is feeding properly. You will find pipes running to cylinders, main bearings and connecting rod bearings.

After the engine has been run several days

and the journals are well seated, adjust the feed pipes, as follows:

Front cylinder, four to five drops; rear cylinder, leave wide open. Main bearings, four to five drops, leave connecting rod bearing feeds wide open.

Each feed pipe has a separate adjustment. If lead pipes overflow, the motor should be stopped and the pipes cleaned out at once.

WHAT OIL TO USE IN YOUR TRACTOR.

	SUMMER	WINTER
Acme	Medium heavy	Medium
Albert Lea	Medium heavy	Medium
Allis-Chalmers	Medium heavy	Medium
Allis-Chalmers (General Purpose)...	Medium	Medium
All Work	Heavy	Medium
American	Medium heavy	Medium
Appleton	Medium heavy	Medium
Atlas	Medium heavy	Medium
Aultman-Taylor	Heavy	Medium
Aultman-Taylor (22-45)	Medium heavy	Medium
Aultman-Taylor (15-30) (Waukesha)	Medium heavy	Medium
Automotive	Medium heavy	Medium
Auto-Tiller	Medium	Light medium
Avery	Heavy	Medium
Avery (5-10 H.P.)	Medium	Medium
Bates Steel Mule	Heavy	Medium
Bean Track-Pull	Medium	Medium
Beaver (Brantford, Canada)	Medium heavy	Medium
Beeman Garden Tractor	Medium	Medium
Belt Rail	Medium heavy	Medium
Besser	Medium heavy	Medium
Best	Heavy	Medium
Big Bull	Heavy	Medium
Blue "J"	Medium heavy	Medium
Buckeye (Ohio)	Heavy	Medium
Cleveland	Medium heavy	Medium
Coleman	Heavy	Medium
Common Sense	Medium heavy	Medium
C. O. D.	Medium heavy	Medium
Craig	Medium heavy	Medium
Creeping Grip	Medium heavy	Medium
Cultitractor	Medium heavy	Medium
Dakota	Medium heavy	Medium
Depue	Medium heavy	Medium
Eagle	Medium heavy	Medium
Elgin	Heavy	Medium
Fageol	Medium heavy	Medium
Farm Horse	Heavy	Medium
Fitch Four Drive	Medium heavy	Medium
Flour City	Heavy	Medium
Fordson	Medium	Medium
Frick	Heavy	Medium

	SUMMER	WINTER
Galloway	Heavy	Medium
Gehl	Medium heavy	Medium
Gile	Medium heavy	Medium
Gilson (12-25)	Heavy	Medium
Gilson (15-30)	Medium heavy	Medium
Graham	Medium heavy	Medium
Grain Belt	Medium heavy	Medium
Gray	Medium heavy	Medium
Hart Parr	Heavy	Medium
Heider	Medium heavy	Medium
Hession	Heavy	Medium
Hicks	Heavy	Medium
Hollis	Medium heavy	Medium
Holt Caterpillar	Heavy	Medium
Holt Caterpillar (Model 45)	Medium heavy	Medium
Huber	Medium heavy	Medium
Ideal (Brantford, Canada)	Medium heavy	Medium
Illinois	Heavy	Medium
Indiana	Medium	Medium
International 8-16	Medium	Medium
International 15-30	Medium heavy	Medium
Junior Ideal (Brantford, Can.)	Medium heavy	Medium
K. C. Prairie Dog	Medium heavy	Medium
Keck-Gonnerman	Medium heavy	Medium
La Crosse	Heavy	Medium
Lang	Heavy	Medium
Lauson	Medium heavy	Medium
Leader	Medium heavy	Medium
Liberty	Heavy	Medium
Lightfoot	Medium heavy	Medium
Little Giant	Medium heavy	Medium
Maxim	Heavy	Medium
Minneapolis	Heavy	Medium
Mogul (I. H. Co.)	Medium heavy	Medium
National	Medium heavy	Medium
Neverslip (20-12)	Heavy	Medium
Neverslip (30-18, 10-6)	Medium heavy	Medium
New Age	Medium heavy	Medium
Nilson	Medium heavy	Medium
Oil Pull (20-40) (Rumely Co.)	Medium heavy	Medium
Oil Pull (12-20, 16-30) (Rumely Co.)	Medium heavy	Medium
Oil Pull (Rumely Co.)	Heavy	Medium
Parrett	Medium heavy	Medium
Pioneer	Heavy	Medium
Plow Man	Medium heavy	Medium
Porter	Medium heavy	Medium
Port Huron	Heavy	Medium
Reed	Medium heavy	Medium
Royer	Heavy	Medium
Russell	Medium heavy	Medium
Russell (Giant)	Heavy	Medium
Sandusky	Medium heavy	Medium
Short Turn	Heavy	Medium
Square Turn 18-35	Heavy	Medium
Standard	Medium heavy	Medium
Stinson	Medium heavy	Medium
Stone	Medium heavy	Medium
Strite	Heavy	Medium
Titan (I. H. Co.)	Medium heavy	Medium
Topp-Stewart	Medium heavy	Medium
Townsend	Heavy	Medium

	SUMMER	WINTER
Turner	Medium heavy	Medium
Trenam	Medium heavy	Medium
Trundaar	Medium heavy	Medium
Twin City	Heavy	Medium
Twin City (Model 16).....	Medium heavy	Medium
Twin City (Model 12-20).....	Medium heavy	Medium
Uncle Sam.....	Medium heavy	Medium
Velie	Heavy	Medium
Victory	Medium heavy	Medium
Wallis Cub (Junior).....	Medium heavy	Medium
Ward	Medium heavy	Medium
Waterloo Boy.....	Medium	Medium
Whitney	Medium heavy	Medium
Wichita	Medium heavy	Medium
Wisconsin	Heavy	Medium
Yankee	Heavy	Medium
Yuba	Medium heavy	Medium
Yuba (Model 12).....	Medium	Medium

CHAPTER VII.

Cooling.

Why It Is Necessary and Various Ways in Which It Is Carried Out.

IT is necessary to waste some of the heat generated by the combustion of the gases in the engine cylinders in order to bring the working temperature of these cylinders down to a point where we can maintain a film of oil between the piston and cylinder walls and also in order to prevent the temperature from mounting so high as to cause warping and weakening of the metal or even melting.

There is another reason, and a highly important one, for cooling the cylinders. Let us consider that the piston is on the intake stroke and that the various parts of the engine are intensely hot. Immediately the cool incoming gas strikes the hot walls it is heated and, naturally, rapid expansion takes place in accordance with the degree to which the gas is heated. This expansion, of course, tends to fill up the space and to prevent more gas from entering the cylinder so that we do not get a full cylinder charge, and naturally the power of the engine falls off. The engineer describes this condition by saying that the "volumetric efficiency" of the engine is impaired.

If, however, we keep the engine cylinder stone cold, which would permit us to crowd in the largest fuel charge, we have an equally bad effect and we lose power from three causes: First,

that to keep the cylinder cold we must take away a very large portion of the heat generated by the combustion of the gases, and every unit of heat taken means a loss of power; second, the chilled cylinder does not further the complete vaporization of the fuel, and it was pointed out before that vaporization is necessary for any body to take fire and burn; thirdly, all those parts that are not vaporized before the fuel is ignited must be vaporized by the heat liberated when the vaporized parts take fire, which means that the rate of combustion will be slow and the power developed will be impaired as a result.

Besides, it being necessary for a substance to be vaporized for combustion to take place, it is also necessary to raise it to its critical temperature—that is, the point at which it will take fire whether a flame is present or not. A match applied to a sheet of newspaper, first converts a small portion of the paper into a gas and raises the temperature of this gas above its critical temperature. The combustion of this gas gives heat enough to gasify the adjacent paper and heat up the new gas, and so the flame travels slowly along until the whole paper is consumed. If, however, we were to place the sheet of paper in a very hot oven, where there was plenty of air and elevate the temperature to a point sufficient to gasify the paper and ignite its gas the whole sheet would burst into flame simultaneously—we would have very rapid combustion.

In the cylinder of the gas engine we simply substitute the gasoline mixture for the newspaper. When the cylinder is cold, the igniting spark must raise a small quantity of the mixture to a point beyond the critical temperature, so that it ignites and the flame so started travels through the mixture. But its spread or travel is com-

paratively slow and the power developed is lessened as a result.

If now, we heat the gases up to a point more nearly approaching their critical temperature, we not only insure thorough vaporization, but we also make it easier for the flame to travel once it is started by the electric spark, and we get very rapid combustion and greater power from the same amount of fuel.

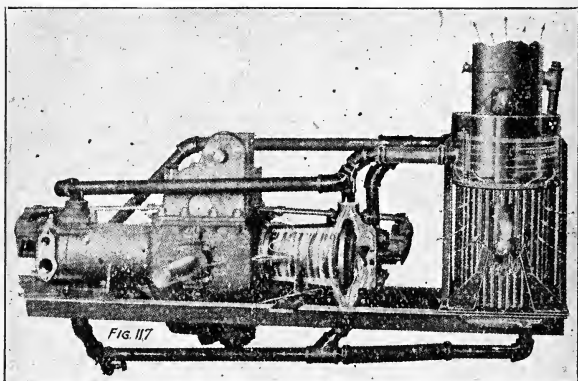

Fig. 117. Thermo-syphon cooling system—solid arrows show water circulation; broken arrows, exhaust and air circulation. No water pump or fan is used on the Avery tractor.

Here, then, we have two contradictory conditions, one calling for cooling of the cylinder in order to give a power increase, and the other calling for heating of the cylinder in order to effect the same result. In order to strike the best possible balance and obtain best results, it is apparent that a compromise is necessary. Indeed, the present internal combustion engine is a compromise in many respects besides this.

All considered, best results from the engine

are obtained when the cylinder walls are maintained at a temperature in the neighborhood of 200 to 225 degrees F. In other words, where water cooling is adhered to, as in the case of practically all tractor engines, the temperature of the cooling water emerging from the cylinder jackets should be in the neighborhood of 200 degrees F. to obtain best results from the engine.

The cooling system of a typical engine is detailed in Figure 117. The cylinders are surrounded with a jacket which is cast integral with the cylinder block, and passages at the top of the cylinder block casting lead to the head casting to conduct the water to a similar jacket provided in the latter (Figure 118-A).

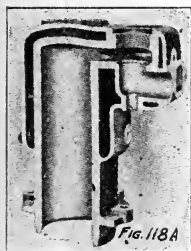

Fig. 118-A. Section showing cylinder jacket.

Water, like other substances, expands when heated, except between the very narrow limits explained in the first chapter, which obviously does not enter into our present consideration. If we had a cubic inch of water and heated it, it would occupy a space larger than one cubic inch at the higher temperature; but its weight would be the same, so that its weight for a unit of volume in the second case must be less than in the first. In other words, the density or specific gravity of water decreases when the water is heated, and since an object of less density than water will float on water, it stands to reason that there will be a tendency for heated water to rise in and float on the top of a body of water at lower temperature.

If, then, we have the cylinder jacket of the engine filled with water and the water adjacent

the cylinder walls becomes heated, the tendency will be for this warmer water to work to the top of the jacket. An outlet pipe is arranged at the topmost front portion of the cylinder head casting and this outlet is attached by means of a section of rubber hose to a tank formed on top of the radiator. The radiator is composed of an upper and a lower tank connected together by a series of vertical copper tubes arranged in rows from front to rear of the radiator; the tubes are passed through a large number of copper plates arranged one on top of another and spaced a short distance apart. The purpose of these plates is not so much to support the tubes as it is to increase the radiating surface providing a great area for contact with the air, just as with a house-warming radiator, the radiating surface is increased by increasing the number of coils of pipe or by providing castings with large surface. It is evident, then, that as the water discharged from the engine into the top header passes downward through these tubes, it will be cooled, giving up some of its heat to the tubes from which it is transferred to the flanges and the air, and in order to insure this transfer of heat, a fan is generally mounted behind the radiator and belted to a pulley wheel attached to the front end of the crankshaft or to some other convenient shaft. This fan creates a suction which draws the air through the passages of the radiator between the flanges and the vertical tubes. In the case of the Avery tractor, pictured herewith, the draught is created by the engine exhaust, no fan being used.

From the lower header of the radiator, another pipe is arranged which conducts the water to a point on the right side of the engine near the middle, where the water enters at the lowest point in the engine water jacket, becomes heated again, rises and continues the circulation.

We call such a system which circulates the water by virtue of the natural tendency for the water to rise when heated and sink when cooled, the natural circulation system or "thermo-syphon system." It has a couple of points of advantage over the system in which the water is circulated by an engine pump; the biggest point in its favor is the fact that it eliminates the pump and the complication which attends its installation and use. Another point in its favor is that the water does not begin to move until it becomes heated, so that the cylinders reach their working temperature more quickly when the engine is started from cold. Larger inlet and outlet water piping is required than with the pump system, due to the fact that the force causing circulation is limited.

It will be noticed that the connections between the engine and the radiator are made with rubber hose of the proper size clamped in place with suitable hose clamps to insure against the hose slipping off and against leakage at the joints. The use of the rubber hose is not so much for the purpose of simplifying attachment and detachment as it is to protect the radiator from the vibration when the engine is in operation which, were metal pipe used, would be transmitted to the radiator and soon cause rupture of the joints.

It is necessary to keep the radiator full of water at all times. Filling is accomplished by taking off the radiator cap and pouring in clean water, preferably rain water or soft water; use hard well water only when none other can be obtained and replace with soft water at first opportunity. Screw the radiator cap back firmly in place when the radiator is filled, to guard against its working off. There is a small over-

flow pipe or tube leading from inside the filler neck on the radiator down the rear right side of the device to a point beneath the pan. This is to provide for expansion of the water which always takes place when the water is heated and which would burst the radiator if means were not taken to get rid of the excess. It also serves to permit the escape of any steam generated in the engine jackets with the engine in operation.

The amount of cooling surface of the radiator

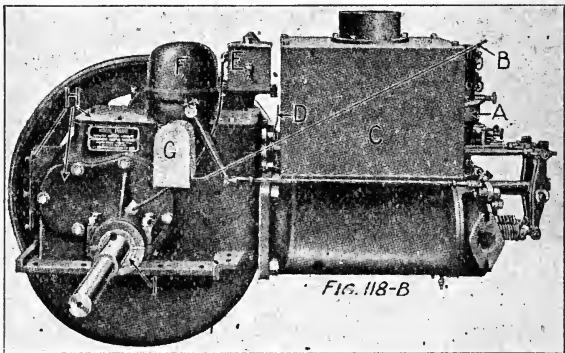

Fig. 118-B. Hopper cooling on Mogul 10-20.

and the water capacity of the system have been so proportioned to the amount of heat it is necessary to get rid of as to maintain the engine cylinders at or near their proper working temperature at all times.

In Figure 118-B is pictured a Mogul 10-20 engine equipped also with a thermo-syphon system, but of very much simpler design. As a matter of fact, it consists simply of a large box or hopper surrounding the single-cylinder of this engine and which takes the place of the water jacket. This box is filled with water and serves

at once as water jacket, water tank and radiator. The heated water simply rises to the top of the hopper and is cooled on contact with the air. The capacity of the hopper is comparatively large so that fairly good cooling is obtained; no fan or forced draught is used.

While the simple hopper system is well adapted to function perfectly on such low-powered engines as the one described above, when we come

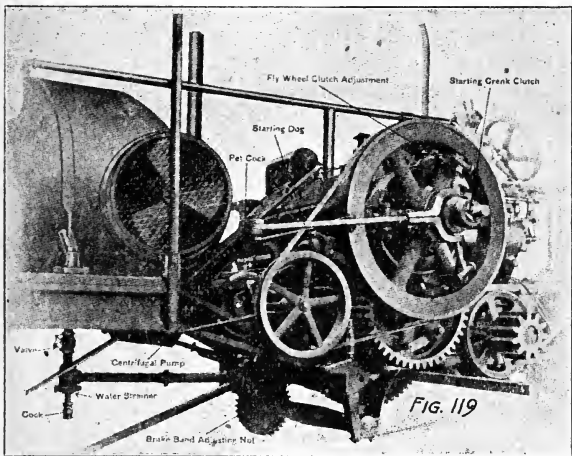

Fig. 119. Pump system on Aultman-Taylor.

to engines of high power more adequate means of cooling must be provided. As a matter of fact, at the present time the manufacturers who are relying on thermo-syphon circulation of the cooling water are greatly in the minority. Most tractor engineers feel that an engine running constantly at nearly full load like the tractor engine, and where temperatures are bound to be high, needs forced water circulation quite as well

as forced oil circulation, and the result is that pump cooling is coming more and more to the fore.

The pump system differs from the simpler thermo-syphon system in one particular only. That is in the employment of a pump—generally of the centrifugal or impeller type—to draw the water from the bottom of the radiator and force it through the cylinder jackets. The centrifugal pump is employed because of its simplicity—it being devoid of valves and checks—and the fact that in case of pump failure the pump offers no impediment to the circulation of the water by the thermo-syphon system, so that the engine will be reasonably well cooled. Figure 119 shows the pump system applied to a typical tractor, the Aultman-Taylor.

There are two other details in connection with tractor engine cooling that it is well to note. The first is the employment of oil in the cooling system instead of water, which is carried out in the case of some of the larger Rumely jobs; and the second is the employment of a water temperature regulator for maintaining the water jackets always at uniform temperature at which the fuel is best handled, a practice which is being introduced by the Case people and which closely follows what has been found best in automobile practice.

The use of oil in the Rumelys determines slightly higher cylinder jacket temperatures than can be maintained with water because of its comparatively low boiling point, bringing the cylinder temperature up to a point which is practically the ideal. At the same time, the oil being non-freezing at any climatic temperatures encountered in this country at least, there is not the slightest need of draining the engine cooling

system during the cold weather and no danger of freezing and damaging the mechanism.

The device used on the Case for temperature control is a simple little thermostat which regulates a by-pass valve, as shown in Figure 120. The thermostat itself comprises a little metal cylinder, corrugated to make it flexible and extensible as to length, to one end of which is attached the rod which actuates the by-pass valve. This cylinder is half filled with a very volatile liquid which when heated expands, creating sufficient pressure within the cylinder to cause it to elongate, moving the rod and actuating the valve.

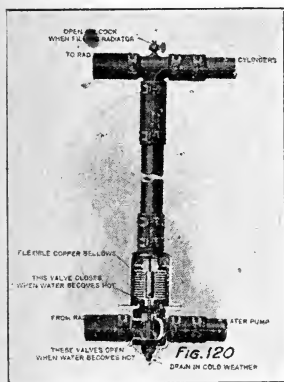

Fig. 120. Syphon regulator showing path of circulation.

It will be seen, by reference to the figure, that the circulating system between the engine jackets and the radiator is "short-circuited" by a by-pass pipe and the thermostat cylinder is placed in this pipe. The arrangement is such that when the water

is cold, the thermostat closes the passage from the radiator to the engine pump and opens the by-pass pipe into the pump intake so that the water does not circulate through the radiator at all, but simply passes through the by-pass.

Naturally, there being only a slight amount of water in circulation, it heats up very quickly and the engine attains its normal operating temperature in no time. As the water heats up, the

thermostat expands and allows more and more cool water to be drawn into the system from the radiator; and it is so set that it will proportion the feed between the two in such a manner as to feed water at a constant temperature to the engine throughout the day and quite regardless of operating conditions and loads carried.

CHAPTER VIII.

Care of the Cooling System.

**Any Leaks That Develop in the Water System
Should be Stopped Immediately.**

IF leaks are at the hose joints, tightening the clamps or replacing the rubber hose with new hose will effect a cure. The hose should be replaced every season with new hose anyway, because the action of the hot water tends to rot it, causing the inner lining to peel off, and the circulation of the peelings will carry them, in time, to the top header of the radiator, where they are likely to block one or more of the tubes, causing partial stoppage of the circulation.

From time to time the drain cock provided at the lowermost point in the radiator, where the water passes out to the cylinder jackets, should be opened and the water drained from the system; the system should be flushed out with fresh water, which will have the effect of cleaning out the rust and any sediment due to the use of hard water. It is well, once in every month, to put a pound of washing soda into the radiator and leave it there for a day or so, permitting the free circulation of the hot soda solution. This will free any scale formed on the inside walls of the cylinder jackets and in the radiator itself as a result of the use of hard water, and will also help loosen any accumulation of rust; the system should then be thoroughly flushed out, preferably by removing the hose connections and turning a hose first through the radiator and then through

the engine jackets. This will carry off any sediment and leave the system perfectly clean.

The fan belt should be kept perfectly tight by means of the adjusting screw provided in the fan bracket. Take up the slack in the fan belt until the fan begins to drag when turned by hand.

There are two gaskets, one on the inlet nipple flange and the other on the outlet nipple flange, to which the connections to the radiator are attached, which will leak occasionally unless the stud screws holding them to the cylinder castings are drawn up tightly. Leakage of water from the cylinder head gasket should be corrected immediately by drawing up on the hold-down bolts by means of which the head casting is fastened to the cylinder block, which will have the effect of compressing the gasket and stopping the leak.

Never put any solid or any liquid containing a solid substance in the radiator to stop leakage. There are several radiator compounds on the market intended for this purpose, which are liquids of a special nature, which solidify or get gummy when they are mixed with warm water and brought into contact with the air. These substances are perfectly safe for use in the cooling system to correct small leaks, and they will actually act to prevent the formation of scale at the same time, when used in accordance with the manufacturer's directions.

Overheating of the engine as evidenced by boiling of the water and poor operation of the motor as a whole may be caused by a variety of troubles. The presence of excessive carbon deposit in the combustion chamber and on top of the pistons will cause it, the cure being to remove the carbon as directed in a previous chapter.

Racing the engine is a frequent cause; running with the spark retarded; poor spark; in-

sufficient oil, use of poor oil or the use of oil of a grade unsuited to the engine will cause overheating; improper carburetor adjustment, giving either too lean or too rich a mixture and thereby causing slow burning, which exposes a greater area of the cylinder walls to the heat; fan blades bent, belt broken or slipping; improper circulation due to clogged or jammed radiator tubes, leaky connections or too little water in system.

The correction for most of these is apparent or has already been explained. Those having to do with the ignition system will be explained fully in a later chapter dealing with this important system.

The repair of a leaky radiator, provided it is not badly broken by a smashup or some similar mishap, is a job that is best left to a mechanic who has specialized in work of this sort unless the man undertaking the job has had quite some experience in the manipulation of soldering tools. The first thing to do is to remove the radiator from the tractor, which is done by disconnecting the hose connections to the engine and undoing the bolts which fasten the radiator brackets to the frame.

With the radiator off, the next step is to locate the leak or leaks. This is done by plugging up the inlet and outlet passages of the radiator, using large cork stoppers if they can be had of ample size, or potatoes in case stoppers are not handy. Then with a tire pump, force air into the radiator through the overflow pipe, at the same time submerging the radiator in a tub of water. The bubbles caused by the escaping air will indicate the place where the radiator is leaking; it should be marked for identification when the radiator is removed from the water. Next place the radiator on a work bench and heat the

tubes around the leak with a blow-torch. When they are just a little hotter than the boiling point of water, ordinary acid soldering solution, made by treating muriatic (hydrochloric) acid with pure zinc, is poured through the fins all over the leaky tubes to thoroughly clean their surfaces.

Then melt a ladleful of solder, which should be ordinary half in half

plumbers' solder, and after blocking the radiator up from the bench sufficiently to be able to hold another ladle

beneath it, pour the solder

through the fins and over the tubes, catching it in the

empty ladle, as shown by the sketch (Figure 121).

Then turn the radiator over and repeat the operation, pouring through in

the opposite direction. Apply more of the soldering solution and heat once again with the

torch until the solder melts and runs into the leaks, sealing them against further leakage.

Before putting the radiator back on the tractor, it is best to test it once again to make sure that

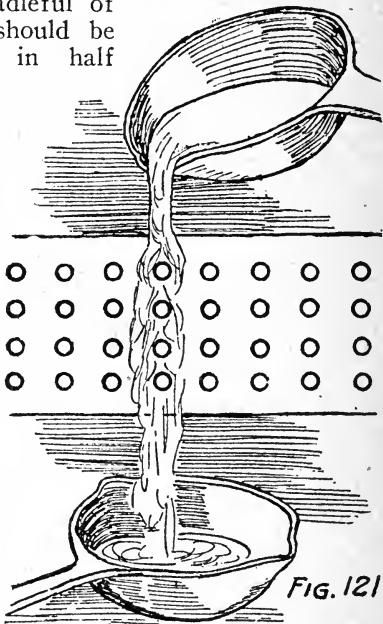

FIG. 121

Fig. 121. Method of repairing vertical tube radiator.

Apply more of the soldering solution and heat once again with the torch until the solder melts and runs into the leaks, sealing them against further leakage. Before putting the radiator back on the tractor, it is best to test it once again to make sure that

all the leaks have been soldered up. In case a tube is jammed, the best plan is to cut it off an inch above and below the cloture and sweat a new piece of tube of the correct length and diameter in place of the piece that has been removed.

During winter weather some precautions must be taken to protect the radiator from freezing, especially when the tractor is left standing with the engine shut off. Freezing of the water in the radiator is bound to cause the tubes to burst and leak, and if the water freezes in the engine jackets, the jacket itself will burst in nine cases out of ten and it will be necessary to have it welded to effect a repair. In some cases of radiator freezing the rupture will be so bad that it will be necessary to replace the radiator with a new one. It is well, therefore, to take the simple precautions necessary to guard against such a contingency.

If the tractor is used only occasionally during the winter months, the best plan is to pour hot water into the cooling system when starting out. This will facilitate starting of the engine. Cover the lower portion of the radiator with a piece of cardboard, so that the cooler water at the bottom of the radiator will not freeze. At the end of the day, drain the cooling system thoroughly by opening the drain cock, letting the engine idle while the water is running out, in order to provide sufficient heat to dry the jackets thoroughly.

If the tractor is used a great deal throughout the winter, the best plan is to use a non-freezing solution in the cooling system. There are several substances which can be mixed with the cooling water and which will have the desired effect of lowering its freezing point. Quite the most commonly used is wood or denatured alcohol. A 20

per cent solution of alcohol and water does not freeze until a temperature of 15 degrees F. is reached; a 30 per cent solution freezes at 8 degrees below zero, and a 50 per cent solution at 15 degrees below. Glycerine and calcium chloride are sometimes used instead of the alcohol.

The trouble with alcohol is that its boiling point is quite a bit lower than that of water, so that it evaporates quickly, and it is therefore necessary to replenish the supply from time to time in order to guard against freezing. The glycerine, on the other hand, attacks the rubber hose connections, causing swelling and peeling, while the calcium chloride forms an alkali solution which sets up electrolytic action between the copper radiator tubes and the solder, causing them to corrode, which, of course, is not at all desirable. There are several compounds on the market intended to prevent freezing of the cooling water and which are said to be free from any of these defects.

During the last year or so it has become quite common practice to drain the water from the cooling system and fill it up with kerosene during the winter months. This practice will work out to advantage in cases where the tractor is used often but not driven very hard and is stopped frequently. For very hard plugging the use of kerosene is not to be recommended, for the simple reason that its specific heat—its capacity to absorb heat—is only about one-half that of water while its conductivity of heat is only about one-third that of water. It is evident that it has not the capacity for carrying away enough of the heat from the cylinders to provide for proper cooling if the engine is run all out for long intervals.

CHAPTER IX.

Ignition System.

How the Spark Is Produced and Controlled to Obtain the Desired Results.

IN order to ignite the mixture in the cylinder of the engine, a spark which is hot enough to raise the gas adjacent to its critical temperature and thereby set fire to it is essential. The simplest way of producing a spark in the cylinder of an engine at exactly the time required to ignite the mixture is to make use of the electric current, which in its action is practically instantaneous.

To thoroughly comprehend the operation of the ignition system we must start right at the beginning and learn something of the nature of the electric current and its generation. We all know what a magnet is—a common horseshoe magnet such as the schoolboy uses for a plaything. Let us consider its properties for a minute. It is nothing more than a simple bar of steel, bent in the shape of a horseshoe and magnetized, and it has the property of attracting things made of iron and steel, and to a lesser degree, manganese and nickel. More careful examination of the properties of the magnet reveal that the action of the two ends is not the same and we have come to know one end as the North or Positive end of the magnet and the other one the South or Negative pole. We have discovered that issuing from the North pole there are certain lines of magnetic force which

spread apart somewhat in the air and then converge again and enter the South pole of the magnet. It is these lines of magnetic force—their exact nature is quite unknown to us—which give the magnet the property of attracting substances susceptible to magnetic influence.

Let us consider that we have such a magnet (Figure 122) and that it is a very strong one, which means that there are a whole lot of magnetic lines of force crowded into a very small space between the two poles. Let us suppose, also, that we have a loop of wire like a hoope

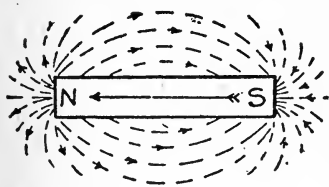

BAR MAGNET
AND
LINES OF FORCE
FIG. 122

Fig. 122. Typical magnets illustrating lines of magnetic force or the magnetic field set up between the poles.

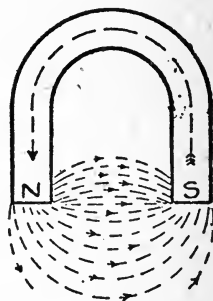

HORSESHOE MAGNET
AND
LINES OF FORCE

—a complete circle, in other words. We hold the hoope in one hand and the magnet in the other and we move the loop in so that the wire on one side of the loop enters between the poles of the magnet and crosses or cuts every one of the lines of magnetic force traveling between these poles. While we are actually moving the wire through the field of magnetic force and actually cutting lines of force, there is a current of electricity generated in the wire and flowing through it. And furthermore, the faster we cut

the lines of force—that is, the greater number of lines cut in a given interval of time—the greater will be the strength of the current.

Now let us suppose that we have carried the loop all the way in and have reversed the motion and are bringing it out again; it is then cutting the lines of force in the opposite direction, and while it is actually moving, there is a current generated in the wire. But this time, due to the reversal of the direction in which the lines of force are cut, the current flows in the opposite direction to which it was flowing in the first instance. If now we keep the coil of wire moving in and out, we will have a current flowing as long as there is movement, and it will reverse itself each time the direction of motion is reversed and we have what we term an “alternating” current. If it were always flowing in the same direction we would call it a direct current.

The important thing to bear in mind is that there must be a complete circuit for the current to flow through—if we open the loop of wire the current stops immediately, regardless of the movement of the coil—and that the current flows only while the lines of magnetic force are actually being cut. It makes no difference whether we move the magnet or move the coil; provided the motion is such that lines of force are cut by the wire, we set up a current of electricity in the loop. It is a fact, also, that both can be held still and by decreasing and increasing the strength of the magnet, we cause the lines of force themselves to move, and in so moving to cut the coil of wire and get the same effect—but always to get a current lines of force must be cut by the wire loop. This latter principle should be borne distinctly in mind, as it is all-

important to a thorough understanding of the ignition system.

The current generated by the simple apparatus we have described would be so slight as to be imperceptible and incapable of measurement except by the finest of instruments. Since the current strength depends upon the number of lines of force which we cut in a given interval of time, it is obvious that there are three ways of increasing its strength:

1. Increase the speed of the moving part, whether it is the magnet, the coil or the field itself.

2. Increase the number of lines of force, or in other words, the strength of the magnet.

3. Increase the number of turns of wire on the coil, for it is obvious that two loops will cut twice as many lines of force in a given interval of time as one loop.

Here we have concretely stated the elements of a practical dynamo. If we employ field magnets of great strength, and if we employ a large number of turns of wire on the revolving armature, and if, furthermore, we rotate the armature at high speed, we produce a current at fairly high pressure or voltage.

But even so, it takes very high electrical pressure to force a current to jump over even the smallest air gap. If the wire in a circuit be broken and the ends separated by even the slightest distance, for instance, the current is immediately interrupted and does not jump the gap and produce a spark except at the very instant when the break occurs. And we can bring the two ends together just as close as we care to, without making them actually touch, and the current flow will not be re-established.

In order to get the current to jump a gap of

sufficient length to ignite the mixture in our cylinders, therefore, we have to resort to special means to increase the pressure far and above the voltage that can be created directly by a dynamo such as we have described above of a size to be applicable to the tractor engine. There are two methods of accomplishing this. The first is to make use of an induction coil or a transformer coil, and its operation will not be hard to comprehend, provided we have grasped the fundamental principles of the dynamo just described.

Let us go back once again to our loop of wire and consider that we have current flowing through it. It is a peculiar fact that whenever current flows through a conductor such as a wire, all around that wire we create a field of magnetic lines of force exactly as we have lines of magnetic force issuing from the magnet. Any wire with electric current flowing through it, therefore, is in reality a magnet, and the strength of the magnet will depend upon the strength of the current flowing through it, and the number of turns of wire on the coil. Now, if we coil the wire up into a helix, which is a coil like an exhaust valve spring, having all the layers insulated from each other, and inside that coil we place a core made of soft iron wire, the lines of magnetic force engendered by the passage of the current will flow through that core and one end will become a North pole and the other a South pole and the lines of force from the North pole will bulge out around the coil on all sides and bend in again to meet the South pole while current is flowing through that coil.

If we pass more current through the coil the lines of force will bulge out further, like a barrel, and if we suddenly stop the flow by breaking

the circuit, they will very quickly collapse in toward the coil and then stop flowing. But the big point to bear in mind is that varying the strength of the field by making and breaking the circuit will cause that magnetic field to move quickly away from and toward the coil.

Now let us say that we have such a coil with one end attached to the dynamo terminal or to one pole of a battery of dry cells and the other end grounded so that the circuit is complete. And supposing on top of that coil, but fully insulated from it, we wind another coil consisting of a very large number of turns of very fine wire and we fasten one end of this second coil to the spark plug terminal and the other end we ground. Then we have substantially a complete circuit, the only break in it, provided the plug is screwed into place in the cylinder, is the spark gap in the plug. By "grounding," we mean attaching the wire to the metal part of the machinery so that the machine itself, such as the engine frame, becomes part of the circuit. All ignition circuits are grounded in this way.

Supposing now that we have the dynamo running so that current is flowing through the first coil, which we will call our primary coil; then the magnetic field set up around this primary coil will completely envelop the second coil, which we will call our secondary coil. If now we suddenly break the dynamo or primary circuit, causing a sudden stoppage of the current flow, the magnetic field issuing from the primary circuit will suddenly collapse, cutting all of the very many turns of wire on the secondary coil so that we have an abundance of lines of force moving at very rapid rate and cutting a great number of wires—every condition favorable for the production of high electrical pressure, and conse-

quently we can take from the coil, just at the instant the primary circuit is broken, current at sufficiently high pressure to jump the spark plug gap and return to the grounded end of the secondary circuit through the metal parts of the engine.

This arrangement of the primary and secondary circuits is shown in detail in Figure 123, except that a battery of dry cells is substituted for the dynamo in order to make the operation clear.

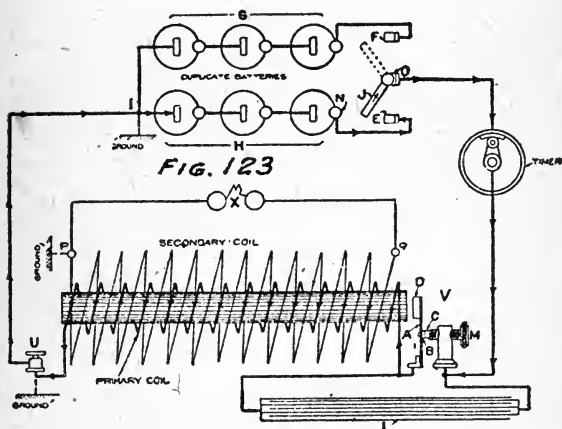

Fig. 123. Construction of conventional induction coil used for ignition purposes.

The primary circuit is represented by the heavy line and the arrows indicate the direction of flow. Considering the switch at E and F closed, the current starts and flows through the timer, which is also considered to be making contact and completing the circuit, to the binding post M. Thence through the contact C to spring contact B and through the heavy coil around the soft iron core and out to the grounded terminal

U. Thence through the metal parts back to the grounded terminal of the battery at I. It was said that when the current is flowing through the primary, the core really becomes a magnet. Such being the case, it attracts the little piece of soft iron D mounted on the contact spring A and in pulling it it separates the contacts B and C and breaks the circuit. The magnetic field immediately disappears and the spring draws the armature back and the contacts again meet and re-establish the circuit and the same thing occurs all over again. The spring keeps on vibrating, alternately making and breaking the circuit, first building up and then destroying the magnetic field around the primary coil, keeping it in constant agitation so that it is continually causing lines of magnetic force to be cut at a very rapid rate and consequently, in the secondary coil shown in lighter line on top of the primary, there is generated a current at very high pressure or voltage.

From one of the secondary terminals, the plug cable leads to the spark gap X, which in the case of the ignition coil is the terminal on the spark plug, while the other secondary terminal is grounded so that the current jumps the gap to the grounded terminal on the spark plug and makes its way back through the metal parts of the engine to the grounded secondary spark coil terminal. It will be understood from what we have said of the nature of the secondary current, that extra precautions must be taken to prevent its escape, since its pressure is so high that unless well insulated it will pass to the metal parts of the tractor and complete the secondary circuit without bothering to cross the spark plug gap, and in such a case the cylinder will miss fire, since there is no spark occurring in it to set fire

to the mixture. For this reason, the secondary wiring leading from the high-tension terminals of spark coils to the spark plug terminals are made of very heavily insulated ignition wiring and care should be taken in case replacement is necessary to use secondary wiring for the plug cables. The primary wiring, on the other hand, which carries the current at low pressure, need not be so heavily insulated, since the voltage is not sufficient to cause it to jump an air gap or break down the insulation.

When we start the flow of electric current, it acquires a certain amount of momentum in a manner somewhat similar to bodies which are in movement. When we come to stop it suddenly it offers some resistance and tends to persist in its forward movement. If, then, we open the contact points B and C, the primary current flowing through the circuit, due to this momentum, tends to keep on flowing and this continued flow is evidenced as a blue spark across the air gap which is formed between the points. The spark is undesirable from two standpoints. In the first place, it causes burning and pitting of the contact points, and in order to resist the heat of the spark it is necessary that these points be made of heat-resisting metal. In days before the war, platinum was the metal invariably used, but owing to its scarcity at present, tungsten and tungsten alloys are being used with very good results.

The second bad effect of this spark across the points is that just so long as a spark is present, current must be flowing, as it is the current which is the cause of the spark. It will be remembered that to set up an intense current in the secondary we said it was necessary to cut the greatest number of lines of force possible with

the coil in the shortest interval of time—in other words, it is necessary to destroy the primary magnetic field as quickly as possible. It is desirable, therefore, to eliminate this spark so that the current in the primary circuit will stop short and the field will be instantly destroyed.

To do this, and eliminate the spark, we make use of a special little device called a condenser, which is connected up to both of the contact points on the circuit breaker, so that when the points open it in reality bridges the gap left between them. It is indicated by the letter L in Figure 123. The condenser is composed of alternate layers of tinfoil and paraffin paper which serves to insulate one tinfoil layer from the next. Every second layer of tinfoil is brought out on one side of the condenser, all being fastened together and connected to a terminal, and every second layer is treated in the same manner on the other side of the instrument, so that one terminal is completely insulated from the other. The device, therefore, offers no path for the current.

It has, however, the singular property of being able to absorb electrical current and the amount it will absorb depends upon the area of the tinfoil used in its construction. When the contact points are opened, the onrush of the current, due to its inertia, causes it to flow into the condenser, charging it, and checking the tendency of the current to flow across the points and cause a spark. When the contact points come together again, the condenser is discharged through the primary circuit, helping to establish the circuit again.

To use a crude analogy, it acts in a manner similar to the air dome or chamber used on a fire engine. If the fireman suddenly turns off the hose nozzle with the pump in operation, the

water, due to its inertia and the action of the pump, is forced into this air chamber compressing the air above it. If this chamber were not provided, the water would burst the hose just as in the electric system the inertia of the current will cause it to jump the gap between the opening contacts when no condenser is provided to absorb the current. When the fireman opens the nozzle again, the air pressure forces the water out of the dome through the hose, helping to re-establish the flow of water and give a good, strong stream.

We find that with a plain coil without a condenser, the spark is very weak—altogether too weak to jump the plug gap in the engine cylinder and that sparking at the circuit breaker soon causes the points to burn and wear away. With the condenser in the circuit, we get a fine hot spark with none of this trouble.

There generally is a separate spark coil used for each cylinder. They are very compact, the condenser being embodied right in the coil, which is protected with a wax composition insulation and which has the little electromagnetic circuit breaker mounted right on top of the coil unit. There are only three terminals on the coil, because, since one end of the primary coil and one end of the secondary are grounded as described above, to simplify the construction, the grounded ends of the coils are connected together inside the insulation and only one ground wire serving for both primary and secondary coils is brought out to the metal contact.

It is necessary, of course, to pass the magnetic current through the proper coil at exactly the instant the spark is required in the particular cylinder which is at the top of its compression stroke and ready to fire. For this purpose we

use a little rotary switch called a timer, which is mounted on the front end of the camshaft so that the rotary contact member revolves at half the speed of the crankshaft. The timer (Figure 124) consists of a ring of fiber insulating material in which are embedded four short segments of brass mounted diametrically opposite one another. Contact is established between these segments and four screw terminals or binding posts mounted on the outside of the timer.

The rotary contact member comprises a lever fitted with a comparatively large roller at one end, the lever being pivoted to a fulcrum attached to the end of the camshaft by means of a screw thread and lock nut. At the

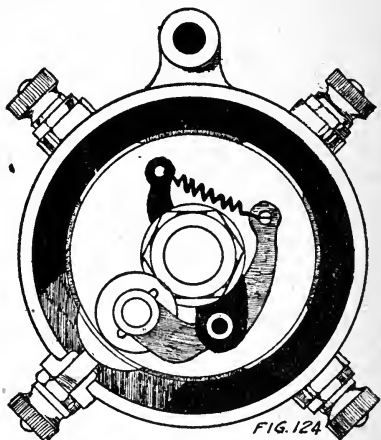

Fig. 124. Construction of typical timer or commutator.

other end of the lever is a helical spring anchored to a projection on the fulcrum arm, the arrangement being such that the spring keeps the roller constantly in contact with the inner side of the fiber ring on which are placed the brass contact segments. The ring is held stationary, although it is adapted to turn through a short arc, so that when the engine is in operation the roller makes one complete circuit of the ring for every two revolutions of the crankshaft and makes contact

with each of four segments once. A metal cover provided with an oiler is fitted to the commutator to keep out the dirt and keep in the light machine oil which is used for lubrication.

It will be seen that the rotary contact maker is not insulated from the camshaft—in other words, it is “grounded” to the engine. Each time it makes contact with one of the segments, therefore, the coil to which this segment is attached is also grounded, so that the primary circuit is completed, current flows through that particular coil, but not through any of the others, since they are not grounded and the circuit is not complete, and the circuit breaker vibrates and we get current from the secondary coil which is conducted from the proper terminal in the middle row of terminals on the back of the coil box to the spark plug in the cylinder ready to fire. It jumps the gap, ignites the mixture, returns through the metal of the engine and through the timer to the ground wire which, it will be remembered, is attached to the grounded terminals of both primary and secondary circuits.

Figure 125 gives a cross-sectional view of a typical spark plug screwed into the cylinder and also indicates the path of the secondary current. N represents the high tension terminal on the coil from which the current passes immediately the timer establishes contact to the terminal on top of the plug. It then flows down through the central electrode, as indicated by the arrows, jumps the spark gap—two gaps are indicated in the plug illustrated—to the grounded electrode which is attached to the spark plug shell. As the shell is screwed into the metal cylinder, the current is grounded and travels back to the grounded secondary coil winding through the metal parts of the engine.

The plug consists of an outer shell of steel or brass adapted to screw-into the plug hole in the cylinder, an inner insulator generally made of porcelain, special stone composition or mica and through which runs the central or insulated electrode, and a compression nut and packing or gasket by means of which the various parts are

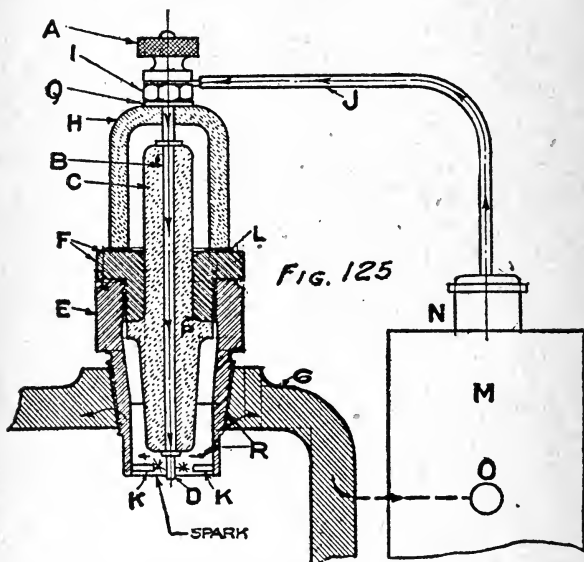

Fig. 125. Construction of a typical spark plug.

held together so as to correctly insulate the central electrode and at the same time make the construction perfectly gas-tight and prevent loss of compression. The illustration shows a special type of plug provided also with an outer insulating shell, adapted to keep moisture from the main insulator and thus prevent short-circuiting of the plug, for it is a fact that with the high-

tension secondary current, moisture either on the plugs, the coil or the wiring will result in the current taking the easiest way back to ground and it will become short-circuited and will fail to pass through the plug and across the spark gap and missing will be the result.

To go back to the case of the burning newspaper which was used as an illustration in one of the previous chapters: if we light one corner of it with a match, it takes some little time for the flame to spread and set the whole paper in flames. In the mixture in the cylinder we are igniting the gas at just one corner—in the little cylinder pocket in which the valves are mounted, to be exact—and it takes an appreciable interval of time for the entire body of gas to become ignited and develop its greatest heat and consequently the greatest pressure on top of the cylinder. In order to obtain maximum power from the engine, it is necessary that we should apply this maximum pressure or push on the top of the piston just as, or very shortly after, it starts on its down stroke. If we have a slow-speed engine, the travel of the piston is comparatively slow, and if we ignite the gas just as the piston reaches the top of its stroke, the very rapid travel of the flame results in our obtaining the maximum pressure very nearly at the top of the stroke and we obtain full power.

With a high-speed engine, however, the piston travel is exceedingly fast, and if we wait to ignite our gas at the very top of the piston travel the piston will be quite some distance down before the flame has spread all through the mixture and developed the maximum pressure. We will have only a portion of the working stroke to travel and cannot, therefore, take full advantage of the pressure we have developed; moreover, a

large portion of the cylinder wall will be exposed to the intensely hot gases at the moment of maximum pressure, and as a result we will have a tendency for the engine to overheat.

We overcome this condition on a high-speed engine by a little dodge which we call advancing the spark. That is, we cause the spark to occur in the cylinder while the piston is still coming up on the compression stroke, and the amount we advance it gives just sufficient time for the full expansion of the gases to take place while the piston is still coming up, so that when it reaches the top we have developed the full pressure, and consequently we get greater power, greater speed and a cooler running engine.

It stands to reason that a tractor engine is neither a high-speed engine nor a low-speed one, but is a variable speed engine, partaking of the characteristics of both. As a consequence, we must so arrange things that we can cause the spark to occur early when running at high speed and late at low speed to get the best results from our engine, regardless of conditions. And so we have, on the modern tractor engine, a variable spark controlled by a spark control lever near the operator, by means of which the operator can cause the spark in the cylinders to occur at the proper time to meet the conditions called for by the speed of the engine.

This variation is brought about by rotating the body of the timer through a slight arc, this being accomplished by means of rods and levers attached to the spark control lever. If, for instance, we rotate the timer body in a clockwise direction or in the direction opposite to the rotation of the camshaft, we are bringing the contacts up to meet the rotating contact maker and the contact will be established earlier in the

stroke—this we call advancing the spark; when we rotate the timer body in the same direction as the camshaft rotates, the spark will occur later and we call this retarding the spark. The arc through which the timer can be rotated is slight, only about 10 to 12 degrees, which corresponds to 20 to 24 degrees of crankshaft movement; this is because that much advance is sufficient to accomplish the purpose at the highest speeds and further advance is harmful to the engine; it

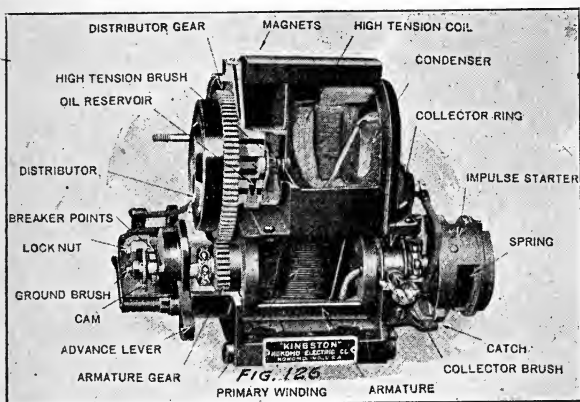

Fig. 126. Magneto and impulse starter.

likewise is not advisable to retard the spark further than is allowed for by this limited arc.

The second method of increasing the electrical pressure to a point where it will jump the plug gap is based upon exactly the same principles as outlined above; but the entire apparatus, instead of being made up in the form of separate units, is included in a single instrument which is called a magneto (Figure 126).

The device comprises a set of strong electro-

magnets, the bars being horseshoe-shaped and made of special steel, rich in magnetic properties, so as to obtain the maximum effect (Figure 127). Arranged to rotate in the magnetic field

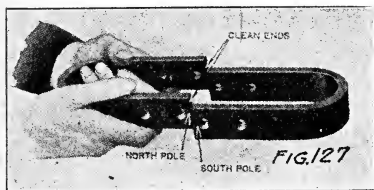

Fig. 127. Testing magnets of a magneto.

set up by these magnets in a manner to take advantage of the greatest number of lines of force, is an armature made of soft iron. Wound on this armature is a coil comprising a comparatively large number of turns of fairly heavy wire. One end of this coil is "grounded" to the armature itself and the other end is brought out to a screw on the end of the armature shaft by means of which it is carried to a circuit breaker. The arrangement is such that the contact of the circuit breaker touches grounded contact located on the breaker disc, so that ordinarily the circuit is complete, and when the armature is rotated the current generated in the coil flows to ground through the circuit breaker and thence back to the grounded terminal of the coil. But twice during each revolution of the armature shaft a little cam (Figure 128) on the

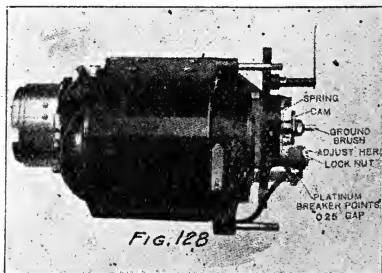

Fig. 128. Magneto breaker points.

breaker housing is brought into contact with the lever of the circuit breaker, lifting it from contact with the grounded contact, and thereby interrupting the circuit exactly as was done with the electro-magnetic circuit breaker described in conjunction with the induction coil. The only difference is that there is but a single break in the case of the magneto. A condenser is shunted across the breaker points exactly the same as with the coil and it serves the same purpose; it checks the flow of current immediately and stops arcing at the breaker points.

From what we know of the performance of the current, it is not hard to see that all around the coil on the armature, we are going to have set up a second magnetic field during the interval when the breaker points are closed and the current is flowing through the coil, because the coil itself is cutting lines of force. Nor is it hard to see that interruption of the current flow by breaking the points apart with the cam action is going to result in a sudden collapse of this second magnetic field twice during each revolution of the magneto armature.

This coil on the armature, therefore, corresponds exactly to our primary coil in the case of the induction coil, and we call it the primary coil of the magneto. Over it we wind a secondary coil comprising a very large number of turns of very fine wire; one end of the secondary we ground to the armature, the connections corresponding exactly to the coil connections, and the other we take to a rotary arm on a distributor (Figure 129) which is built right in with the magneto. This rotary arm turns as the armature rotates, the gearing depending on the number of cylinders on the engine, and the arrangement is such that each time the breaker

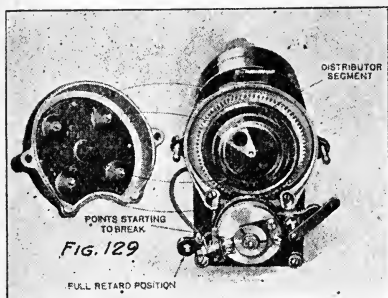

Fig. 129. Distributor construction.

Each segment has a cable leading to a plug, and the connections are made in accordance with the firing order of the engine (Figure 130).

In order to advance and retard the spark, as we did in the case of the coil ignition system, we rotate the breaker box slightly; rotation in the direction opposite to the rotation of the arma-

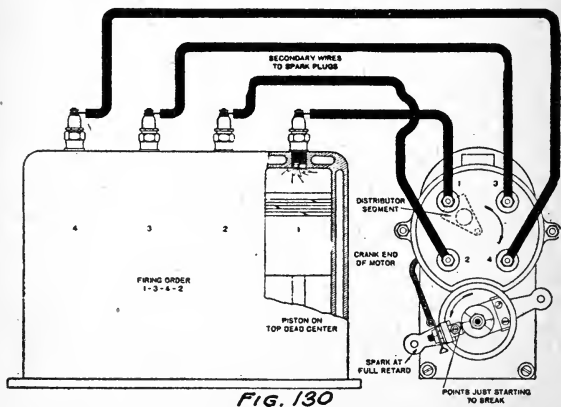

FIG. 130

Fig. 130. How magneto is wired in accordance with engine firing order.

ture results in earlier opening of the breaker points and advance in the time of sparking; rotation in the same direction as the armature retards the spark.

In the case of slow-running engines, where we cannot turn them over fast enough to assure rapid movement of the armature and the production of a good hot spark, the armature is fitted with a special coupling through which it is driven and which we call an impulse starter. It is simply a little device which stops rotation of the armature at some point in its revolution and holds it until the piston is in proper position for the spark to pass, the meantime winding up a spring. Immediately the proper piston position is attained, a trip releases the armature and the spring gives it a very quick turn over the point where the breaker opens, and we have a good, hot spark for starting.

There is one other system of ignition used on a few tractors which is interesting, although not frequently met with at the present time. This we call low tension or "make-and-break" ignition, for the reason that the current is not stepped up to a point where it will jump a gap in the cylinder. In fact, in the cylinder, the sparking points are brought together just before the spark is desired and the current flow is established, and then very quickly separated at the instant the spark is required, with the result that in separating, due to the inertia of the current as described above, the current tends to jump the widening gap and we obtain a spark. Naturally, since a spark across these contacts is just what we want, no condenser is used with this system.

The mechanical arrangement of the system as applied to the Rumely tractor is made per-

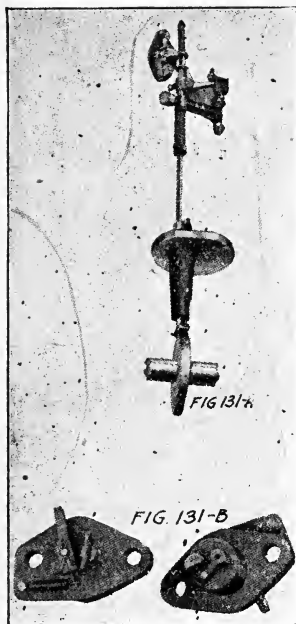

Fig. 131. Low tension igniter on Rumely tractor.

fectly plain in Figure 131. A cam actuates a rod whereby the points are first brought together in the cylinder and then very rapidly separated when the rod tappet drops off the hill of the cam at the instant the spark is wanted. The electrical circuit is very simple; either a low-tension magneto is used and connected directly to the insulated spark plug terminal, the other side being grounded, or else a set of dry cells is employed, in which case the voltage is increased slightly by running the current through an inductance coil, which is a

single coil of very heavy wire wound over a soft iron core. The inductive effect of the field set up by this coil on the coils themselves gives rise to 'self-induction,' whereby the higher voltage necessary to produce an effective spark is obtained.

CHAPTER X.

Care of Ignition System.

THE high-tension magneto is one which furnishes a jump spark without the use of a spark coil. In a magneto of this kind, the armature, in addition to serving the purpose of an ordinary armature, also acts as a coil, or step-up transformer, and with its interrupter and distributor forms a complete ignition system, the only outside parts being the spark plugs.

On account of the K. W. Magneto being of this compact type, eliminating coils, batteries, extra wiring and trouble of shortage, it was chosen as part of the equipment of the "Twin City" motors.

K. W. Magneto, Model HK. By oscillating the breaker box, as shown in Figure 132, the

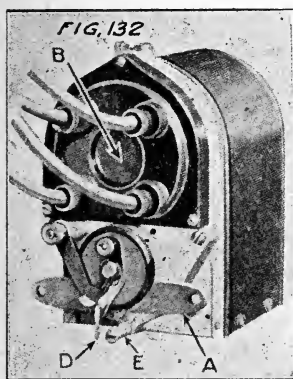

Fig. 132. K-W magneto.

spark is advanced or retarded. Full retard is when the spring is almost touching the spider marked E. When this spring touches the spider, the circuit is grounded, and this stops the motor. It is well for the operator to remove the circuit breaker once a week or more and clean out any surplus oil, then oil the wick in the

roller on the upper contact arm with two or three drops of good sewing machine oil. Make sure that the contact points are clean, and that no oil has lodged on them.

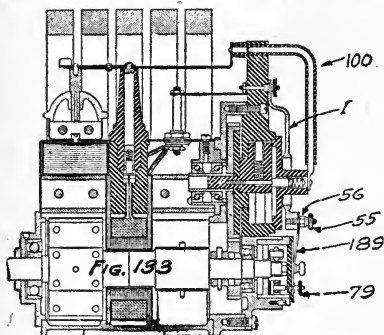

Fig. 133. Cross-section of K-W magneto, model H-K.

Oil on the breaker points is an insulation, and will cause hard starting and probable missing at low speed. In replacing the circuit breaker box, be sure that the contact spring No. 189 has been properly replaced, and that nut No. 79 is tight (Figure 133).

Once a week place a few drops of oil in each of the three bearings. One oiler is located on each side of the rotor shaft and one bearing on the distributor shaft.

At least once a week look at the distributor and see that it is free from carbon dust. This is accomplished by removing the high-tension cable marked 100 and the spider marked No. 1.

K. W. Magneto, Model TK. To set the Model TK is much the same as the HK. It is not necessary to remove the

Oil on the breaker points is an insulation, and will cause hard starting and probable missing at low speed. In replacing the circuit breaker box, be sure that the contact

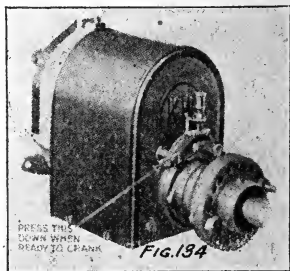

Fig. 134. Impulse starter on K-W magneto.

distributor cover, as a sight glass is provided at "A" through which a small hole locates the position of the distributor brush.

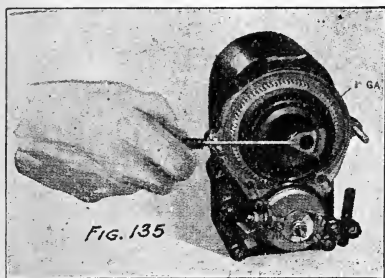

Fig. 135. Testing magneto.

The motor is stopped when projector "D" touches screw "E."

The breaker box is the same.

To time the magneto.

1. Have piston in cylinder

No. 1 at highest point of compression, which is firing position. Have rocker arm "A" (Figures 137-138) horizontal as shown. 2. Shift magneto around until distributor brush "B" touches segment "S," thus connecting with cylinder No. 1. 3. Shift magneto slowly by hand to the right until contacts "P" are just beginning to separate.

This is the firing point of the magneto, and must occur when the piston is at highest point of firing stroke. It will be found that the magneto will have to be

advanced slightly from this setting on account of the impulse starter. Rotate the magneto to



Fig. 136. Filing breaker points.

the right several holes. The impulse starter should trip just as the top center mark on fly-wheel passes center point on engine for about one inch. At this point secure magneto with the two bolts through the coupling flange.

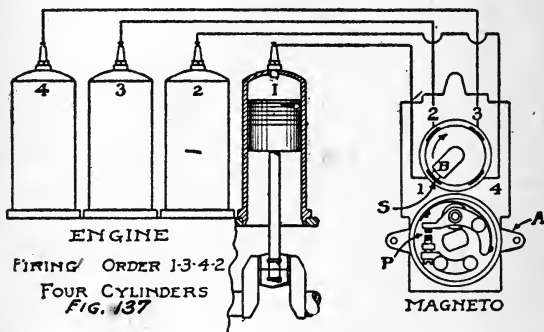

Fig. 137. Timing K-W magneto to a four-cylinder engine.

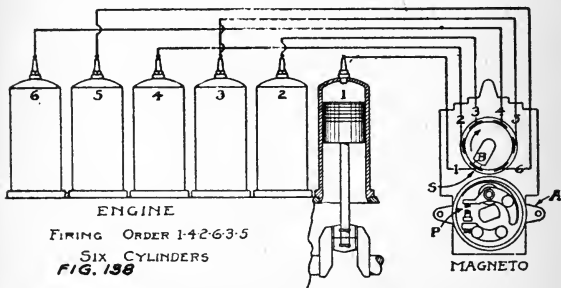

Fig. 138. Timing K-W magneto to a six-cylinder engine.

4. When one cylinder is all right, proceed to connect the others, as shown in the diagram. The firing order is 1, 3, 4, 2 on the four-cylinder motors, and 1, 4, 2, 6, 3, 5 on the six-cylinder motors.

5. Replace parts on the magneto and start the engine to test the setting. See that all nuts and connections are tight, especially nuts 55 and 56, Figure 133. Also see that retainer spring No. 189 has been replaced. To advance shift coupling against direction of rotation. To retard shift coupling with direction of rotation.

Finding which cylinder misses. Open priming cups one at a time. Watch for the flame shooting out, and listen for the sharp report. The cylinder that only hisses and makes no report is the one at fault. The missing might be from the following causes:

1. Too much water when running on kerosene.
2. Too much fuel.
3. Crack in porcelain of spark plug.
4. Poor porcelain in spark plug.
5. Spark plug gap out of adjustment.
6. Valve or tappet sticking.
7. Wire leakage.
8. Magneto trouble.

(1) Usually when the cylinder stops firing from the first cause, a white smoke emerges from the priming cup, and by closing the water valve and changing to gasoline the trouble can be remedied.

(2) Adjustment of the fuel valve and allowing more air will remedy this.

(3) and (4) Change spark plugs by placing the supposedly defective one in a cylinder that is firing.

(5) Gap should be about 1-32".

(6) Remove the valve or tappet and with a fine emery cloth smooth the surface and oil well before replacing.

(7) Remove the wire and hold about $\frac{1}{8}$ " from the cylinder (Figure 139). If there is no spark, remove the wire from its fastenings, but first test out the magneto by placing a wire

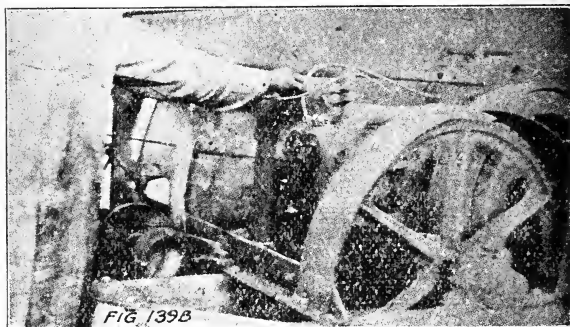
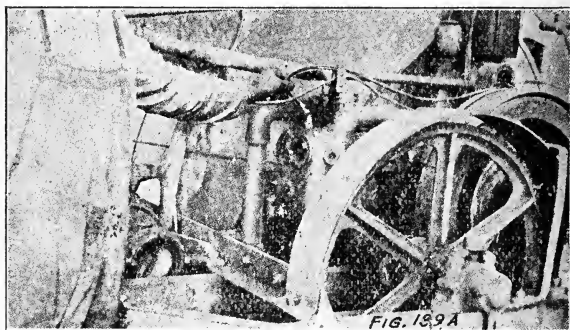

Fig. 139. Detailed method of testing spark plug.

in the defective wire connection on magneto and hold close to some part of the motor. If this shows a spark, then there must be a breakage in the insulation around the wire.

(8) There are two places where the trouble

may be remedied. One is the breaker box and the other the distributor. If these two places are well cleaned, and the trouble has not been located, there might be dirt lodged in between the magnets. Clean this out thoroughly, and if this does not remedy the trouble, the magneto should be removed and shipped back to the factory. It is well for the operator to have an extra breaker box. In this way he would eliminate a

TO TEST SPARK. (See Fig. 139.)

Remove high tension wire from spark plug. Hold it one-fourth of an inch away from the plug. When the engine is turned over with the switch turned onto the batteries there should be a spark. If not, test the batteries.

Do not under any circumstances when testing spark allow the end of the clip on the high tension wires to be more than $\frac{1}{4}$ of an inch from some metal as when you do and the motor is running there is a re-action sets in which is extremely hard on the coil.

If there is a spark, remove the spark plug. Attach the wire the same as though the plug was in place. Lay it on the cylinder. (See cut.) If there was a spark when the first test was made there should be one now. (Have spark plug gap set as per instructions under spark plugs.) If no spark appears at the gap, the chances are that there is a broken porcelain.

CAUTION—At no time should the wires touch the cylinders nor be allowed to get water soaked, as this will cause a short circuit. If a spark appears at the gap and the cylinder does not fire it is reasonable to assume that the cylinder has, (a) too much lubricating oil in the combustion chamber, (b) is wet or (c) does not get the proper mixture of gas, (d) engine has lost compression.

lot of lost time in testing this part of the magneto out by simply removing the old one and slipping the extra one on.

Spark Plugs.—The spark plugs, perhaps, will require more attention than any other part of the ignition system. They will require cleaning from time to time, because carbon is bound to form in any engine burning a hydrocarbon as fuel, and is bound to be troublesome in a case where the engine is over-oiled or where the car-

buretor is adjusted to supply too rich a mixture. This carbon will deposit on the inside of the shell covering the insulator, and since carbon is a good conductor of electrical current, will, in time, present an easier path for the flow of the current than the plug gap, and missing will be the result.

To test for a short-circuited plug, have the engine running at the speed at which the miss is most noticeable. Take a wooden-handled screwdriver and touch the blade to the terminal of the first plug and to the metal of the engine at the same time. This will short-circuit it and there will be no spark. If this plug has been missing, this will have no effect on the operation of the engine; if, however, this happens to be a good cylinder, the miss will be emphasized. Do this with all the cylinders in turn until the one is located where the short-circuiting has no effect on the operation. Remove this plug and replace it with another known to be in good condition and the trouble will disappear.

If a plug is badly short-circuited, it can be tested by laying it on the cylinder with the plug cable attached and seeing if a spark jumps the gap. If it does, the plug is O. K. If not, it needs attention. This test is not conclusive, however, because it is a well-known fact that the spark will jump the gap easier in the open air than under the conditions encountered in the cylinder; it may show a spark on the outside and still fail to function in the engine, which causes quite a bit of annoyance to the inexperienced operator.

One of the larger spark plug makers has brought out a little spark plug cleaner which should be in every tool kit. It is a small glass jar shaped like a chemist's test tube, flared at

the open end, where a rubber collar is fitted of a size adapted to fit the shell screw of the plug. In the jar are a couple of dozen steel needles. The plug is screwed into this jar, which should be half filled with gasoline, and violently

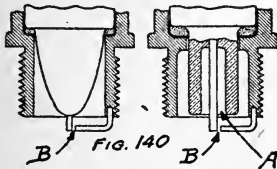

Fig. 140. Spark plug gaps.

agitated for a few moments. The combined action of the gasoline and the pricking action of the needles which come in contact with the entire surface of the insulator, act to clean the

carbon off in a jiffy, leaving the plug perfectly clean.

In the absence of such a device, unscrew the compression nut and remove the porcelain or mica insulator. Clean the carbon off with fine sandpaper or emery cloth; clean inside of the shell. It is a good plan to examine the porcelain insulator for cracks, discarding it if it shows any, and replacing the old one with a new insulator, which the maker is prepared to supply. It is well also to put in new compression washers when cleaning the plugs, as the old ones lose their life. Set up the compression nut firmly to prevent leakage. Always adjust the plug gap (Figures 140 and 141) to .025 or .030

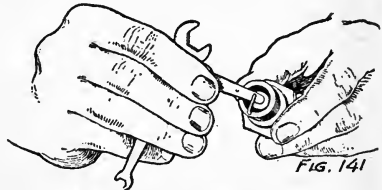

Fig. 141. Method of ascertaining correct adjustment of plug gap with a "feeler" gauge.

of an inch and adjust all the plugs the same. It is well to use one make of plug throughout the cylinders; it makes replacement and handling easier.

Ignition Coils.—The ignition coils as used are perfectly adjusted at the factory, and this adjustment should not be disturbed except to install new contact points or to reduce the gap between the points, which naturally will increase with wear.

If the contact points are found to be burned or pitted, they should be filed flat with a magneto file and then the adjusting thumbnut should be turned down so that with the vibrator spring held down, the gap between the points will be a trifle less than $1/32$ of an inch. Then set the lock nut so that this adjustment cannot be disturbed. Do not bend or hammer on the vibrators, as this will most certainly affect the operation of the cushion spring of the vibrator bridge and reduce the efficiency of the unit.

With the vibrators properly set, if any particular cylinder fails or seems to develop weak action, change the position of the unit supplying the spark to this cylinder, substituting one of the other units for it. If the unit is really at fault, the cylinder which operated badly before will now function properly, but the one with the bad unit will show poor operation. The first symptom of a defective coil unit is the buzzing of the vibrator with no spark at the plug (Figure 142).

Remember that a loose wire connection, faulty spark plug, damp ignition cable or a faulty timer may cause irregularity in the running of the engine. These are points that must be considered before laying the blame on the coil.

When the vibrators on the coils are not properly adjusted, more current is required to make and break the contact between the points, and as a result, when the engine is turned slowly by hand to start, there will not be sufficient current

generated by the magneto to operate the vibrators and hard starting will ensue. Do not allow the contact points to become ragged. If they are in poor shape they are very likely to stick and cause

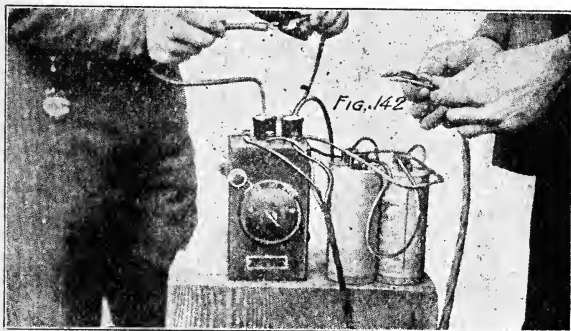

TESTING COIL.

Attach wires to four good strong dry cells as shown in cut.

Wind the red and yellow wires together, making one wire out of the two.

Hold the two high tension cables $\frac{1}{4}$ of an inch apart.

Throw switch on to batteries.

Strike the green wire smartly against the united red and yellow wire.

If the coil is good, there will be a strong spark jump the gap between the two high tension cables.

CAUTION—Do not mistake a damp coil for a defective one. Do not mistake a set of poorly insulated wires which are shorting for a defective coil.

NEVER USE MORE THAN SIX DRY CELLS.

NOTE—In case your coil gets wet or if you are having trouble and think it is in the coil, do not write the factory or send for an expert, but take the coil off, put it in a WARM oven and thoroughly dry it out.

Now, test your coil as instructed, connected to good dry cells and if it then refuses to work, it is time to call for help.

Be sure that it is properly wired, as per the wiring instructions pertaining to this particular magneto.

Fig. 142. Detailed method of testing ignition coil.

unnecessary difficulty in starting and are apt to cause an occasional miss when the engine is running.

In order to determine which cylinder is missing without resorting to the use of a screwdriver to short-circuit the plugs open the throttle until the engine is running at a fairly lively clip and then hold down the vibrators on the two outside coils. Do this with the fingers just preventing the vibrators from buzzing. This will stop two cylinders from firing. If the remaining two fire regularly it is evident that they are not at fault and that the miss must have come from one or the other of the cylinders you have put out of commission. Now relieve No. 4 and hold down the other three; if the engine continues to run, the trouble will be with No. 1. In this manner, all the cylinders can be tested in turn and the missing one located. Do not forget that Coil 4 leads to Cylinder 3 and Coil 3 to Cylinder 4. When the missing cylinder has been located, examine both spark plug and vibrator as well as the wiring.

Commutator or Timer. — The commutator should be kept clean and well oiled with light machine oil at all times. If ignition trouble is experienced which cannot be traced to the plugs or the coils, examine first the wiring leading to the commutator. In case this is chafed and is making contact with some metal part of the tractor, the primary circuit will be short-circuited and we will have a continual buzz of one or more of the vibrators; sometimes the contact will be made intermittently, with the result that the cylinder affected will fire at the wrong time. This is a dangerous condition, and it is highly advisable when this wiring shows wear, to discard it, and put in all new wire, being careful to follow care-

fully the wiring arrangement between the coils and the commutator. If one cylinder persists in missing, and there is no buzzing of the vibrator on that particular cylinder, it is evident that the commutator brush is not making contact on that particular segment, or else the wire to that coil from the commutator is broken inside the insulation. Test for the latter by removing the wire from the commutator terminal and touching to any metal part of the car. If the vibrator buzzes, the trouble is in the commutator; if there is no buzz, the wire is probably broken and should be replaced with a new one.

If misfiring occurs when running at high speed, inspect the commutator. The surface of the ring around which the roller travels should be clean and smooth, so that the roller makes a perfect contact at all points. If the roller fails to make a good contact on any one of the four segments, the corresponding cylinder will not fire. Clean these surfaces if dirty. In case the fiber, segments and roller are badly worn, the most satisfactory remedy is to replace them with new parts. The spring should be strong enough to ensure a good, firm contact between the roller and the segments.

CHAPTER XI.

Engine Troubles.

Their Causes and Remedies.

THE following suggestions may be of assistance in locating and remedying engine troubles. These suggestions are made to enable the operator to effect emergency repairs in the field. In all but the simplest cases we recommend that the trouble be submitted to a competent repairman for correction.

The points under the following subheadings have been arranged, in so far as possible, in related groups.

For example, under the subheading "Engine Refuses to Start," points 2 to 4, inclusive, deal with Ignition; points 7 and 8 with Compression, and points 5 and 9 with Fuel.

It is recommended, in every case of trouble, that the operator look for the simplest cases and apply the simplest remedies first, working up progressively through the more complex.

ENGINE REFUSES TO START.

CAUSES OF TROUBLE.

1. Ignition switch off.
2. Broken electrical circuit.
3. Interrupted electrical circuit.
4. Fouled or broken spark plug.
5. Insufficient gasoline supply.
6. Poor carburetion.

REMEDIES.

1. Turn switch to starting position.
2. Examine wiring for break. See that connections at magneto and spark plug terminals are clean and tight.
3. Lack of insulation may cause a ground connection or a short-circuit. Rewind defective wiring with tape or renew wiring.
4. Clean foul plug; replace cracked plug.
5. Test for gasoline supply at carburetor by flooding. Replenish supply in gasoline tank.
6. Mixture too lean or too rich. Adjust carburetor for correct mixture.

CAUSES OF TROUBLE.

7. Poor compression.

REMEDIES.

7. Test compression by hand-cranking.

(a) The piston rings may be gummed or stuck in their recesses. After a run, while the engine is still warm, introduce about two tablespoonfuls of kerosene through the priming cocks of each cylinder and allow it to remain over night. This will free the rings.

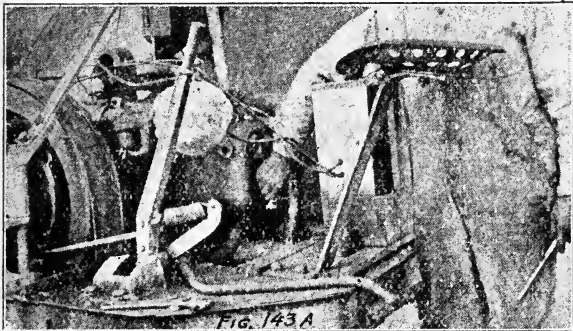

A—Open the pet cock in the end of the cylinder and blow out any oil by turning the engine over.

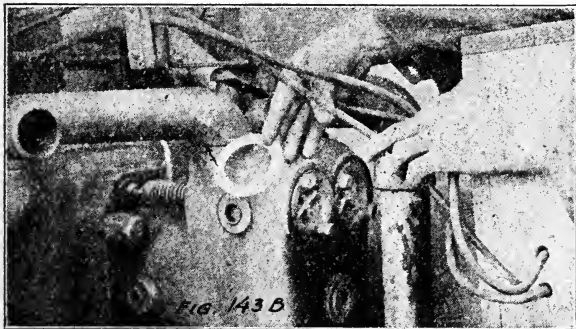

B—Look for a leaky intake manifold gasket.

Fig. 143. Tracing troubles.

CAUSES OF TROUBLE.

13. Worn or broken piston rings.

REMEDIES.

line is indicated. Further, the jet of carburetor may be clogged, in which case remove and clean jet.

13. Renew worn or broken rings. Use correct oil—an oil which will form a perfect piston ring seal.

ENGINE MISFIRING.

1. Carbon on spark plugs.
 2. Insufficient gasoline supply.
 3. Fuel mixture too "lean."
 4. Fuel mixture too "rich."
 5. Valve stuck.
 6. Intake manifold leaks.

1. Clean or replace plugs. Select correct oil to meet requirements of engine. Adjust carburetor for correct mixture.

2. Replenish supply. See that "shut-off" cock in gasoline line is wide open and that there are no leaks.

3. Too much air; too little gasoline.

4. "Rich" mixture will be indicated by misfiring in the cylinders.

5. Clean valve stem with kerosene.

6. Examine for air leaks and repair.

ENGINE STOPS.

1. Ignition switch off.
 2. Broken electrical circuit.
 3. Contact in timer poor.
 4. Insufficient spark.

1. Turn switch on.

2. Examine terminals for loose connections. Examine wiring for poor insulation or break.

3. Clean and make adjustments for strong contact.

4. (a) Magneto demagnetized. Have remagnetized.

(b) Spark plug points improperly adjusted. Adjust gap between spark plug points to a space of about the thickness of a postcard. Too wide or too small a gap will interfere with proper ignition.

5. Replenish supply and note that carburetor float chamber is full.

5. No gasoline.

ENGINE OVERHEATING.

1. Over-retarded spark.
 2. Incorrect timing of valves.
 3. Throttled exhaust.
 4. Clogged muffler.
 5. Clogged radiator.

1. After starting, spark should be advanced as far as possible at all times unless engine labors.

2. The correction of this trouble should be left to a competent garageman.

3. See that exhaust passages are clean and that exhaust valves raise sufficiently.

4. Disconnect and clean out soot and products of incomplete combustion.

5. Introduce cleaning compound into radiator and allow it to circulate while car is running from 50 to 100 miles. Then wash out thoroughly with clean water. Drain and refill.

CAUSES OF TROUBLE.

6. Deficient water circulation.
7. Fan not working.
8. Racing of engine on low gear.
9. Continued use of low gear.
10. Lack of oil, or incorrect oil.
11. Incorrect carburetion.

REMEDIES.

6. (a) Test for clogging of radiator or water jackets.
(b) Test for clogging of water hose.
7. Lubricate bearings; tighten belt.
8. Partially close throttle, thereby decreasing speed of engine.
9. Use low gear *only when necessary*.
10. Fill lubricating system with correct grade of oil.
11. Adjust carburetor for correct mixture.

ENGINE KNOCKS.

1. Spark advanced too far.
2. Carbon deposit.
3. Fuel mixture too "rich."
4. Loose bearings.
5. Worn bearings.
6. Loose flywheel.
7. Engine labors.
8. Carburetor float leaking.

1. Retard spark advance lever on quadrant of steering wheel to prevent premature ignition.
2. Results in preignition. Remove accumulated carbon from combustion chamber and make sure that piston rings are free in their recesses. Use correct oil.
3. Reduce gasoline feed by adjusting carburetor.
4. Have engine bearings fitted properly and tightened.
5. Refit, or, if necessary, renew bearings.
6. Make flywheel fast to shaft.
7. Change to lower gear.
8. Remove and repair float.

EXPLOSIONS IN MUFFLER.

1. Over-retarded spark.
2. Insufficient spark.
3. Fuel mixture too weak.
4. Exhaust valve stuck.

1. Advance spark for earlier ignition.
2. (a) Magneto demagnetized. Remove and have remagnetized.
(b) Spark plug defective. Renew plug.
(c) Spark plug points improperly adjusted. Adjust gap between spark plug points to a space about the thickness of a post-card.
3. Too much air; too little gasoline. An unconsumed fuel charge is forced into muffler and this charge is fired by a subsequent charge. Adjust or clean carburetor so that proper fuel mixture for complete combustion is admitted into combustion chamber.
4. Remove valve cap and free valve in guide. Regrind valve if necessary. See that spring has proper strength.

OVERHEATED EXHAUST PIPE.

1. Over-retarded spark.
2. Clogged muffler.

1. Advance spark for earlier ignition.
2. Disconnect muffler and remove soot and products of incomplete combustion.



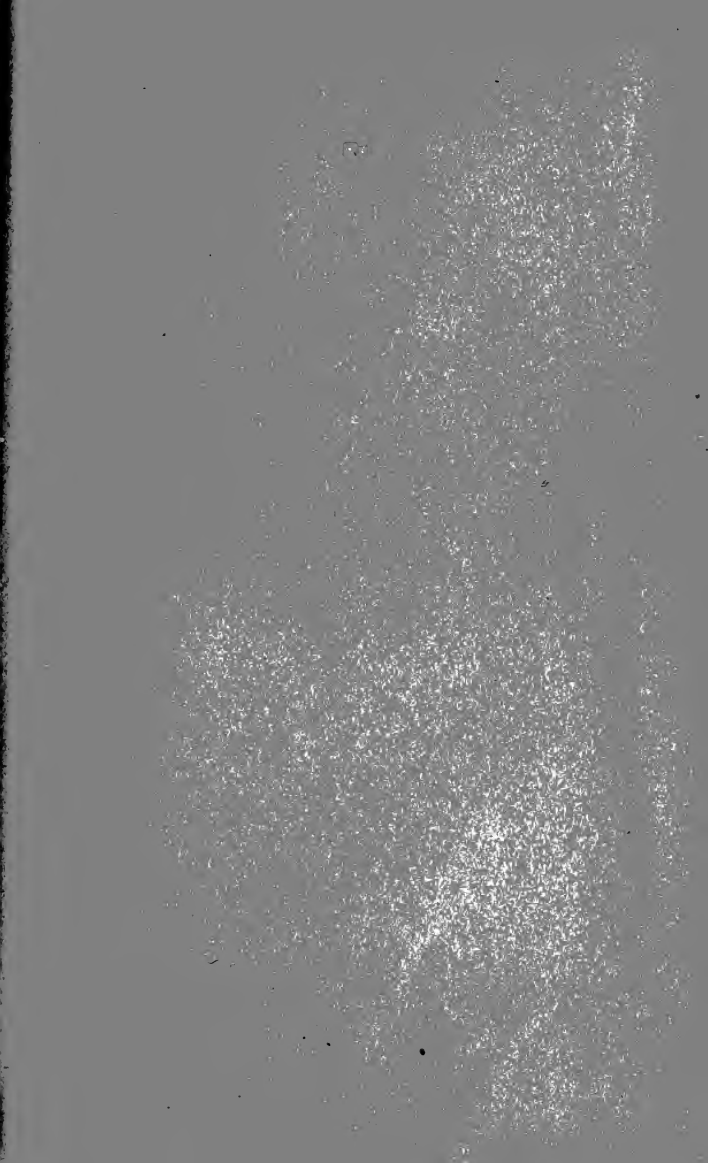

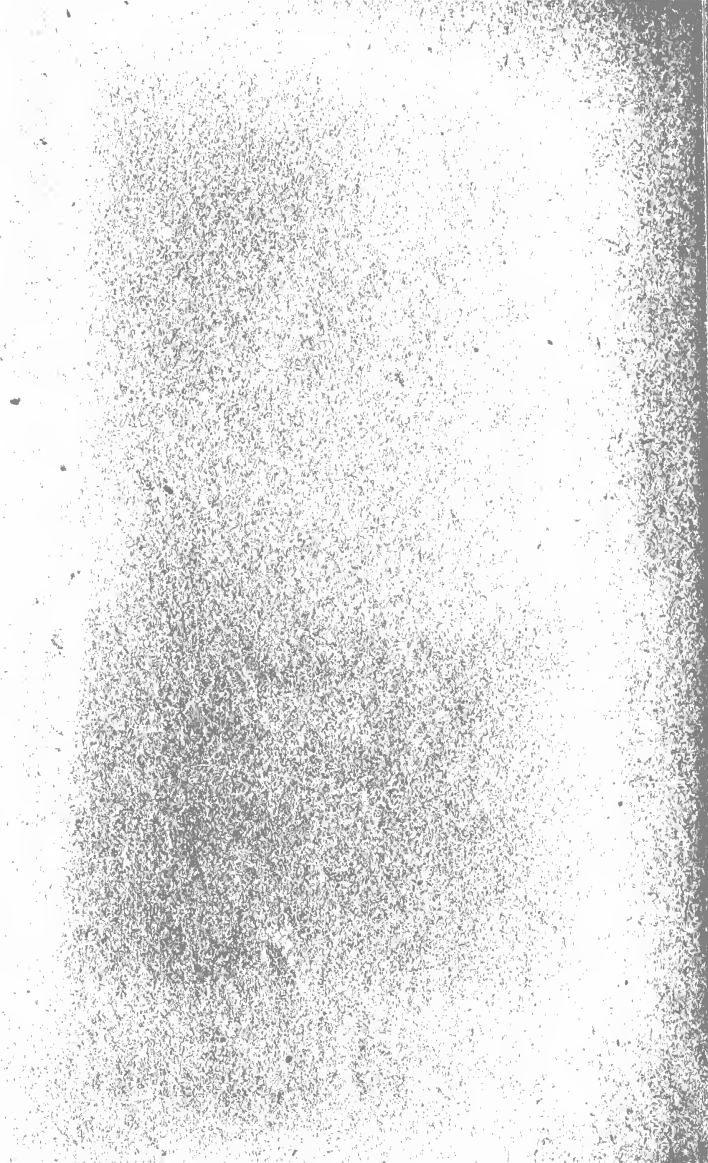





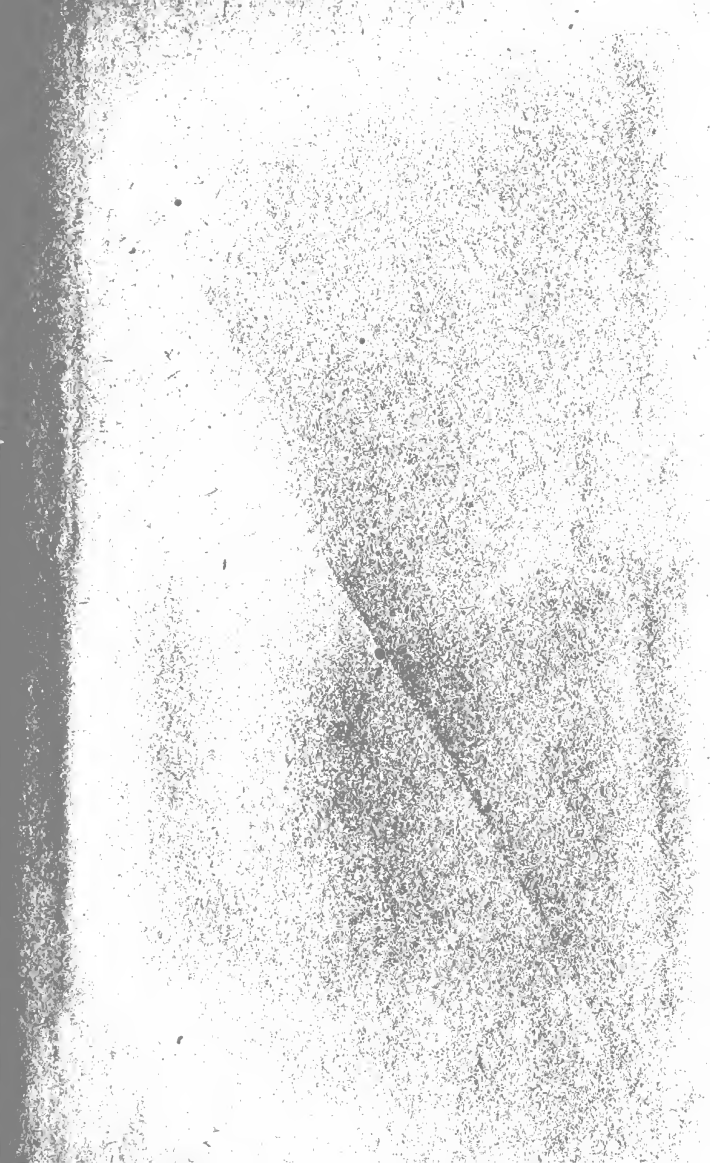

FEB 15 '84

APR 12 '84

477		TL233
Hallock, E.F.		H28
Tractor engines.		

PHYSICAL
SCIENCE
LIBRARY

TL233
H28

UNIVERSITY OF CALIFORNIA LIBRARY



3 1175 00483 7681

