

BRAND SECURITY FOR PHOTOGRAPHY

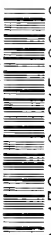

3 1761 01215183 3





TRAITÉ
DE
GÉOMÉTRIE DESCRIPTIVE.

OUVRAGES DE L'AUTEUR.

- DISCOURS** sur l'art du Trait et la Géométrie descriptive 1 fr. 25 c.
TRAITÉ DE PERSPECTIVE, contenant les Tracés pour les Tableaux plans et courbes, les Bas-Reliefs et les Décorations théâtrales, avec une Théorie des effets de perspective; 1 vol. in-4°, avec atlas in-folio de 45 planches, dont 8 doubles..... 40 fr.
RECHERCHES sur les surfaces réglées tétraédrales symétriques..... 4 fr.
MÉMOIRE sur l'appareil de l'arche biaise, suivi d'une analyse des principaux Ouvrages publiés sur cette question et d'une réponse à des critiques sur l'enseignement de la Stéréotomie à l'École Polytechnique. (Extrait des *Annales du Conservatoire des Arts et Métiers*.)..... 2 fr.



L'Auteur et l'Éditeur de cet Ouvrage se réservent le droit de le traduire ou de le faire traduire en toutes langues. Ils poursuivront, en vertu des Lois, Décrets et Traités internationaux, toutes contrefaçons, soit du texte, soit des gravures, et toutes traductions, faites au mépris de leurs droits.

Le dépôt légal de cet Ouvrage (II^e Partie) a été fait à Paris, et toutes les formalités prescrites par les Traités sont remplies dans les divers États avec lesquels la France a conclu des conventions littéraires.

Tout exemplaire du présent Ouvrage qui ne porterait pas, comme ci-dessous, la signature de l'Éditeur, sera réputé contrefait. Les mesures nécessaires seront prises pour atteindre, conformément à la loi, les fabricants et les débitants de ces exemplaires.

TRAITÉ

DE

GÉOMÉTRIE DESCRIPTIVE,

PAR JULES DE LA GOURNERIE,

MEMBRE DE L'INSTITUT, INSPECTEUR GÉNÉRAL DES PONTS ET CHAUSSÉES,
EXAMINATEUR DE SORTIE A L'ÉCOLE POLYTECHNIQUE,
PROFESSEUR DE GÉOMÉTRIE DESCRIPTIVE AU CONSERVATOIRE DES ARTS ET MÉTIERS.

Les Mathématiques ont des inventions très subtiles, et qui peuvent beaucoup servir tant à contenter les curieux qu'à faciliter tous les arts et diminuer le travail des hommes.

DESCARTES (*Discours de la Methode*).

SECONDE ÉDITION.

DEUXIÈME PARTIE. — ATLAS DE 52 PLANCHES.

PARIS,
GAUTHIER-VILLARS, IMPRIMEUR-LIBRAIRE
DE L'ÉCOLE POLYTECHNIQUE, DE L'ÉCOLE CENTRALE DES ARTS ET MANUFACTURES,
SUCCESSEUR DE MALLET-BACHELIER,
Quai des Augustins, 55.

1880

(Tous droits réservés.)

QA
501
L35
1880
A-ins
pic. 2

24030
4/12

AVERTISSEMENT.

Les tailles ou hachures que l'on voit sur un grand nombre de figures ont différentes significations. Sur les quinze premières Planches, elles indiquent des ombres propres ou des ombres portées.

Les *Planches XXIV, XXV, XXVI et XXVII* sont consacrées à l'étude d'une surface d'ombre. La partie de cette surface qui limite l'ombre est indiquée par des hachures. Sur la *fig. 254*, les hachures indiquent l'étendue occupée par l'ombre dans une section de la surface.

Les surfaces représentées sont, en général, considérées comme recouvrant des corps : on a mis des hachures sur les sections planes auxquelles ces corps sont limités. Par exception, les surfaces représentées sur les *fig. 288, 306, 307, 310 et 311* sont considérées comme de simples feuilles ; pour distinguer leurs deux faces, on a supposé que l'une était blanche et l'autre noire : cette dernière est indiquée par des hachures.

Sur la *fig. 194*, des tailles ont été mises sur la partie coupée du mur de la cheminée. Aux *fig. 272 et 273*, la section du terrain est indiquée par de petites tailles.

Sur les figures consacrées à la démonstration des théorèmes et à l'explication des constructions, on ne considère sur les surfaces que les lignes représentées, et, par suite, les parties de ces lignes qui ne dépassent pas les plans coordonnés sont toujours en trait plein. A cette catégorie appartiennent les *fig. 237, 242, 243, 244, 264, 276, 282, 296, 297, 300, 302, 303, 305, 317, 318 et 319*.

TABLE DES FIGURES.

Planches	Figures	Articles du texte.	Planches	Figures.	Articles du texte	
I.....	183.....	322, 323		230, 231.....	436, 440	
	184.....	379, 380		232.....	437	
	185.....	324		233.....	443	
II.....	186.....	381		234.....	446, 447, 449, 472, 474, 475	
	187.....	429, 430		XXI.....	235.....	448
III.....	188-190.....	325-329		236.....	452, 739-740	
	191-193.....	328		237.....	453, 454, 487	
	194.....	329		238.....	442	
IV.....	195.....	326		239, 240.....	462, 463	
	196.....	330, 331		241.....	510	
	197.....	335		XXII.....	242.....	455, 456
V.....	198.....	332-335		243.....	456	
	199, 200.....	382-391		244, 245.....	457-460, 463, 476	
VI.....	201, 202.....	388-391		246, 247.....	478, 479	
	203.....	397-399		XXIII.....	248.....	467, 468
	204.....	485		249.....	502, 521	
VII.....	205.....	486		250.....	467	
	206.....	336-341		251-253.....	521	
	207, 207 <i>a</i>	586		XXIV.....	254.....	491
VIII.....	208, 209.....	392-396		255.....	488-494, 517, 521	
	210.....	681		256.....	493 (note)	
	211.....	586		257.....	439, 491	
IX.....	212.....	342-350		258.....	367	
	213.....	351-355		XXV.....	259, 260.....	492
X.....	214.....	451		XXVI, XXVII.....	261, 262.....	493-501, 505-507, 511-520, 526, 527, 531, 532, 541
	215.....	356-369		263.....	507	
	216.....	369		XXVIII.....	264.....	510 (note)
XI.....	217, 218.....	370-376, 435		265, 266.....	521	
	219.....	373-375		267.....	522 (note)	
	220.....	676		268, 269.....	626, 627	
XII.....	221.....	400-403, 406-409		XXIX.....	270.....	597, 598
	222.....	412-416		271.....	601	
	223, 224.....	416, 417, 419		272.....	548-551, 564-565	
XIII.....	225.....	410		273.....	552-554, 557, 558	
	226.....	420, 602		XXX, XXXI.....	274, 275.....	559-563
	227.....	422-424				
XIV.....	228.....	426-428				
	229.....	433				

Planches	Figures.	Articles du texte	Planches.	Figures	Articles du texte.	
XXXII.....	276.....	588-590	XLII.....	302.....	} 682-687, 692, 693, 697, 698	
	277.....	607, 609		303.....		688, 690
	278.....	613		304.....		694, 695, 702, 703
	279.....	591, 592		305.....		699-701
	280.....	587	XLIII.....	306.....		705, 706
XXXIII.....	281.....	610-612		307.....	707-709	
	282.....	593-596, 600		308, 309.....	715-717	
	283.....	615	XLIV.....	310.....	723-726	
	284.....	621, 622	XLV.....	311.....	719-721	
	285.....	611		312.....	727	
XXXIV, XXXV.	286, 287.....	577-579		313.....	710-714	
XXXVI.....	288.....	603-606, 608, 613	XLVI, XLVII ..	314, 315.....	729-731, 736, 737	
XXXVII.....	289.....	614	XLVIII.....	316.....	735-738	
	290.....	609	XLIX.....	317.....	749-754	
	291.....	680		318.....	752-754	
	292.....	625		319.....	755-757	
	293.....	633	L.....	320.....	} 738-762, 764, 765, 767-773	
	294.....	644		320 <i>a</i>		753
	295.....	678	LI.....	321.....	} 761, 762, 764-766 774	
XXXVIII.....	296.....	658-661, 663, 667	LII.....	322.....		744
	297.....	645-647		323.....	745	
XXXIX.....	298.....	649-655		324.....	763	
XL.....	299.....	664-666, 668		325.....	746	
	300.....	662				
	301.....	671-675				
	301 <i>a</i>	674 (note).				

Fig 183.

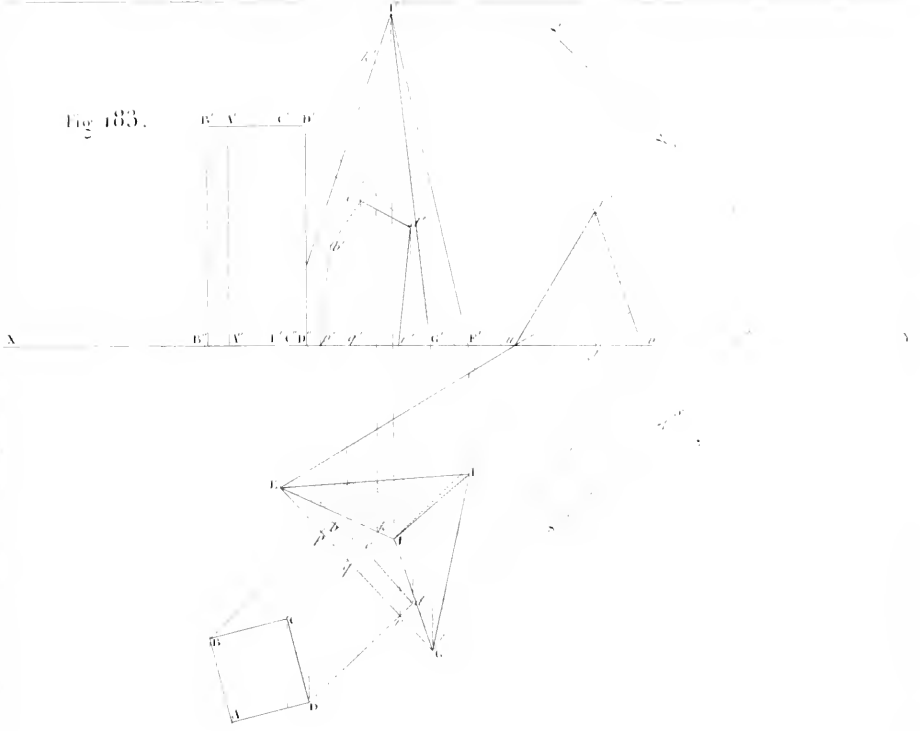

Fig 184.



Fig. 185.

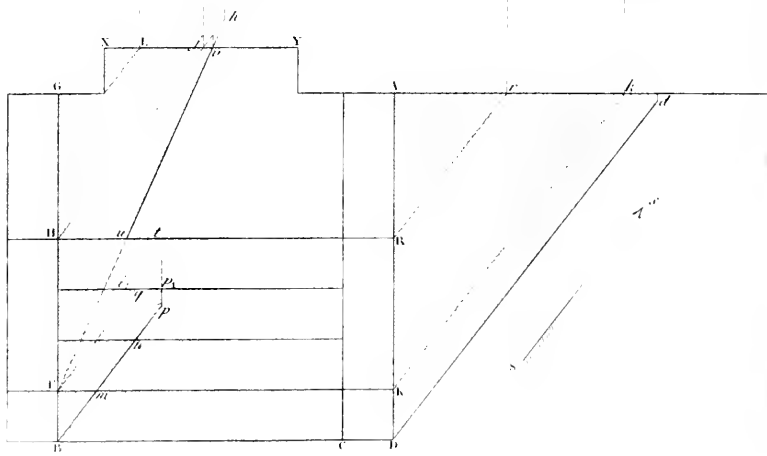
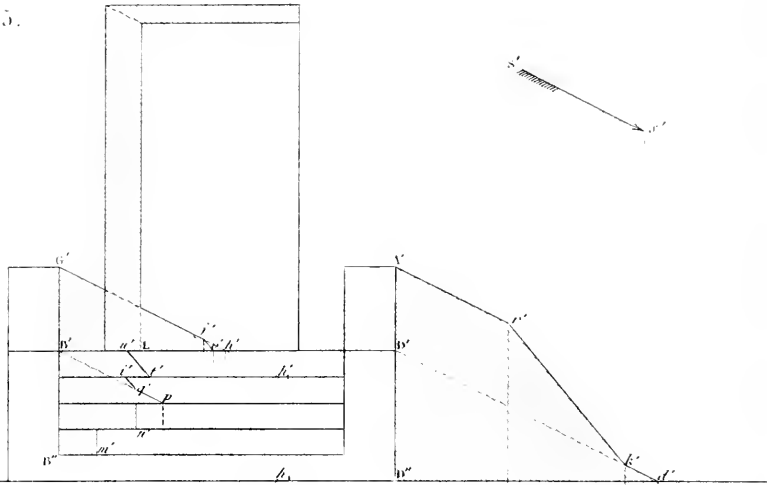

Fig. 186.

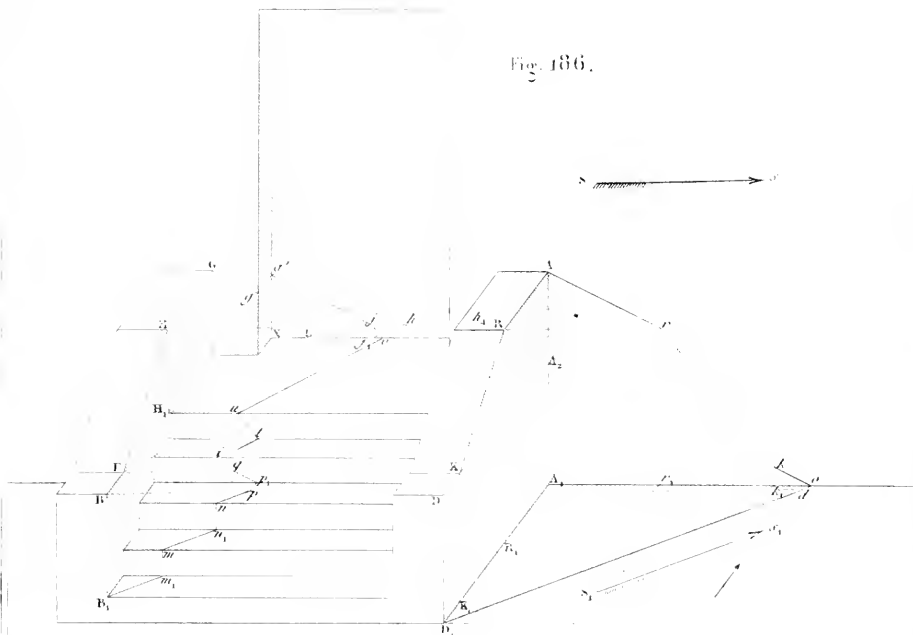

Fig. 187.

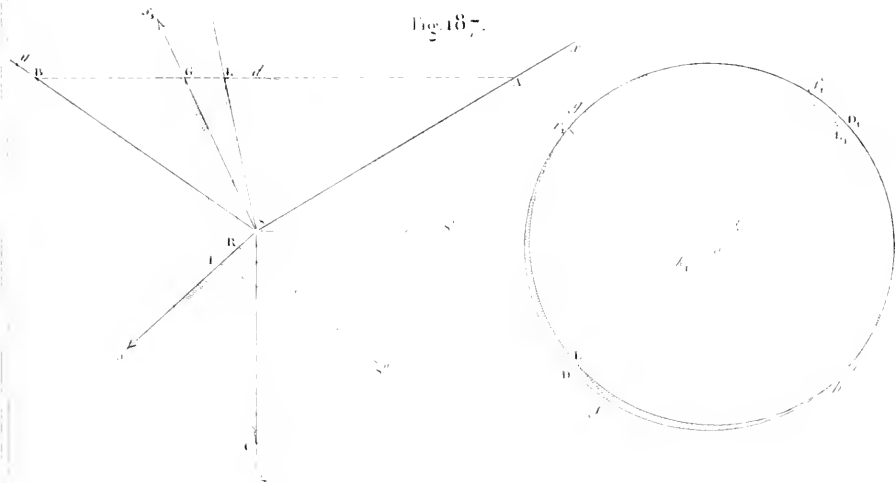

Fig. 189.

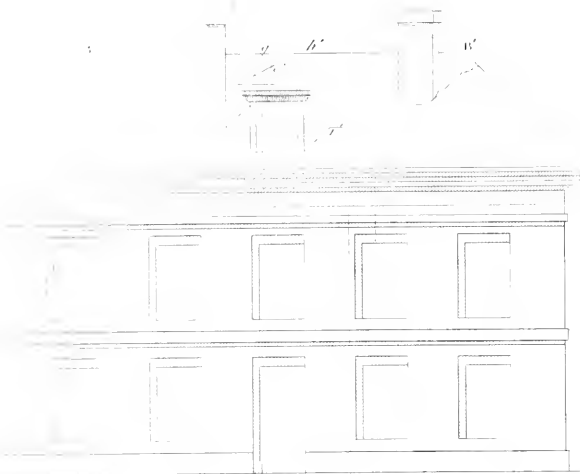

Fig. 190.

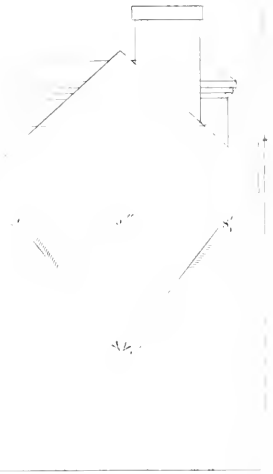

Fig. 188.

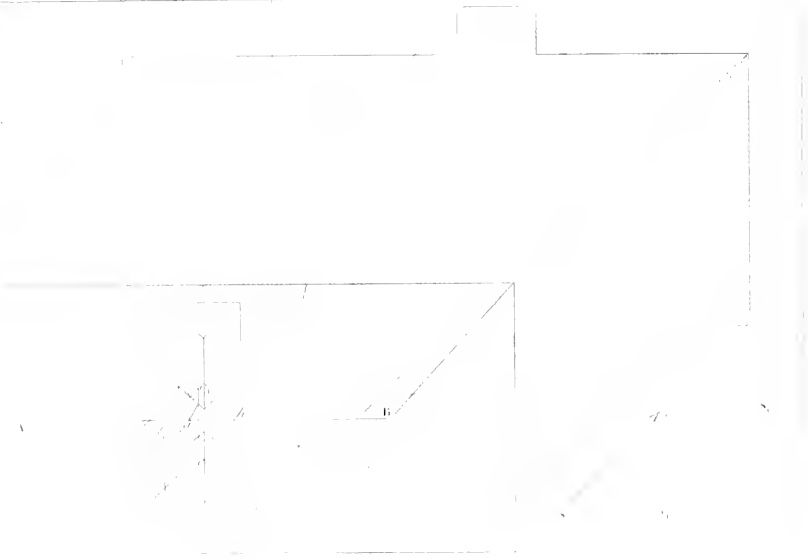

Fig. 102.

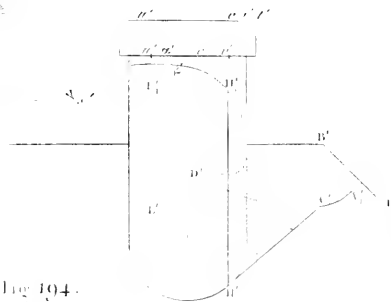

Fig. 104.

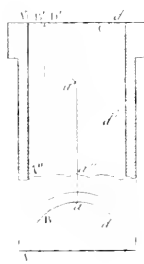

Fig. 101.

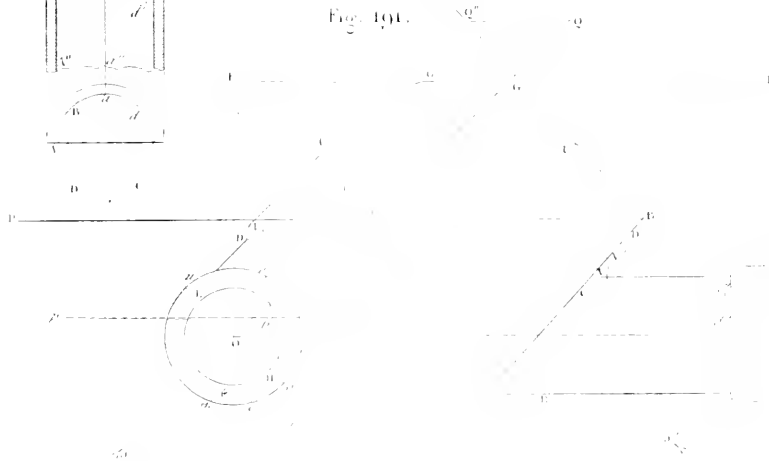

Fig. 105.

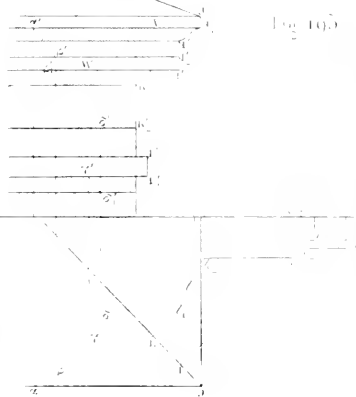

Fig. 103.

Fig. 196.

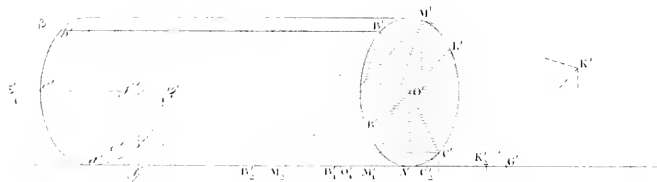

Fig. 197.

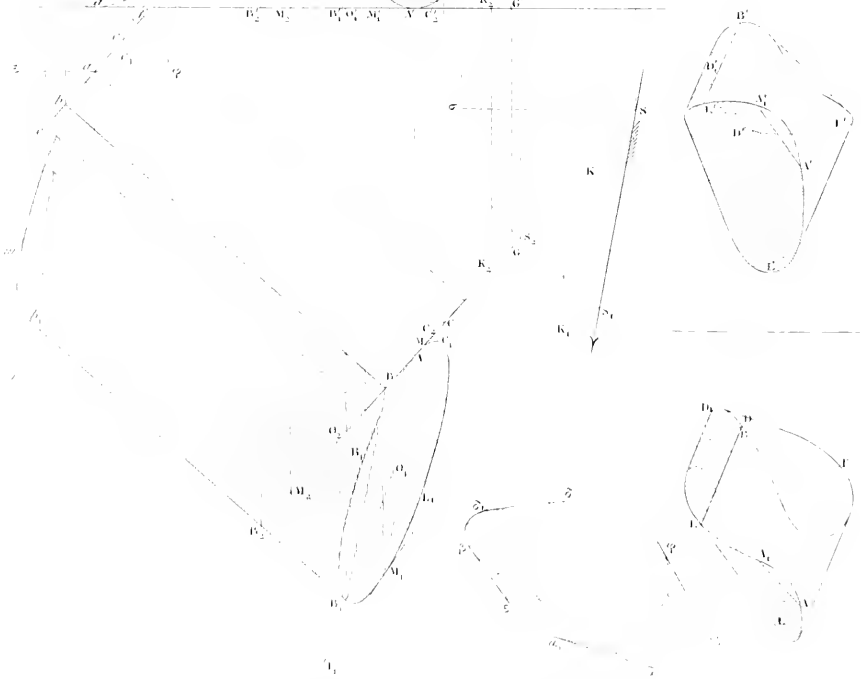

Fig. 108.

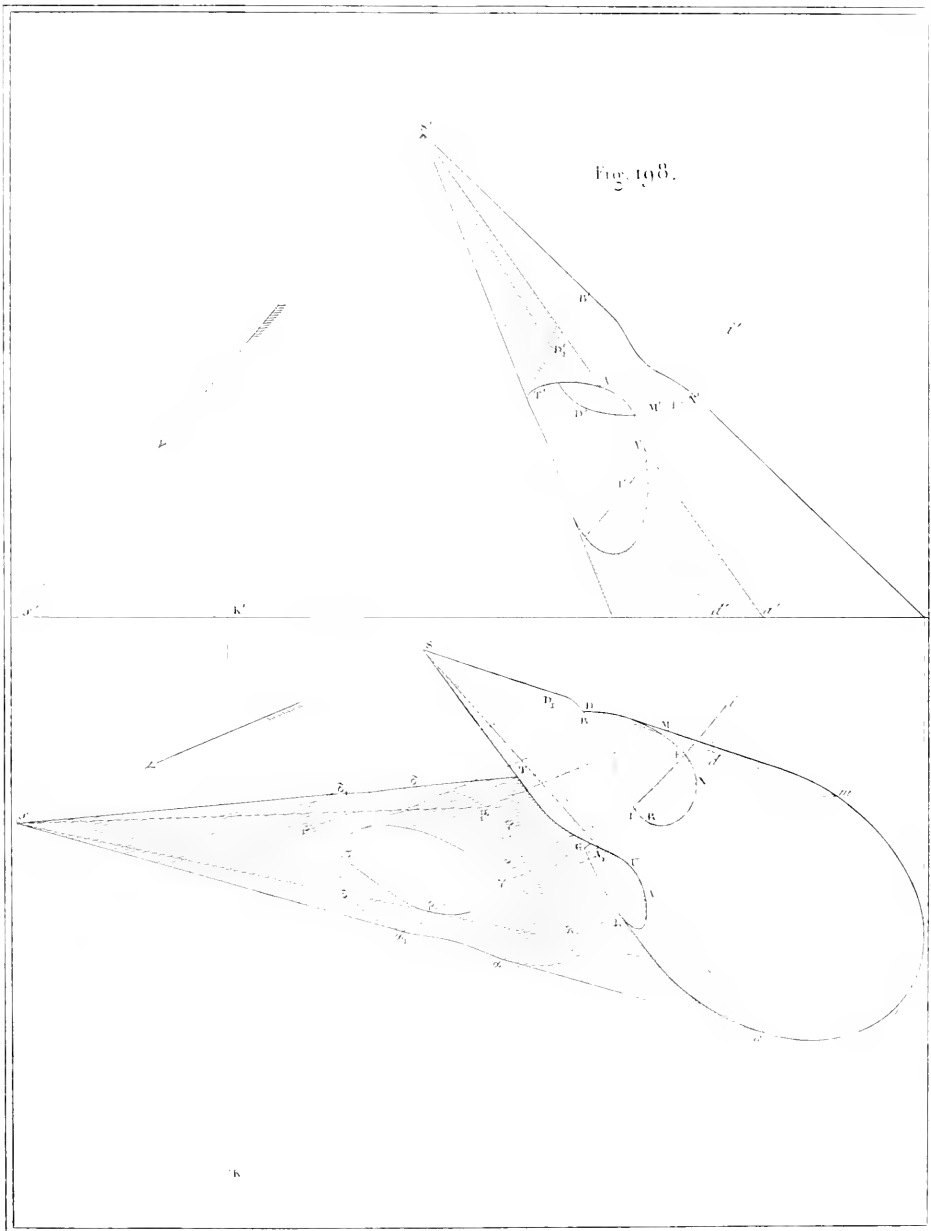

Fig. 201.



Fig. 199.

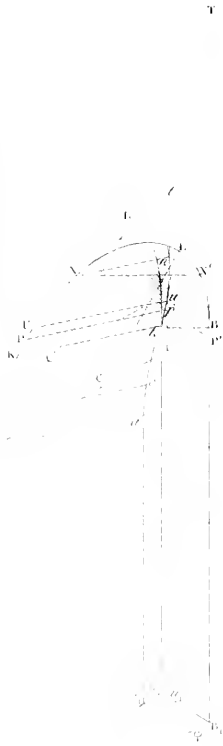

Fig. 202.

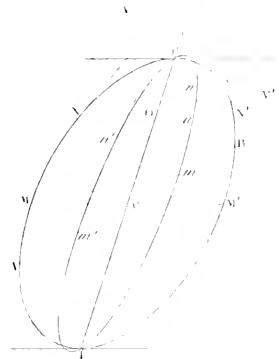

Fig. 200.

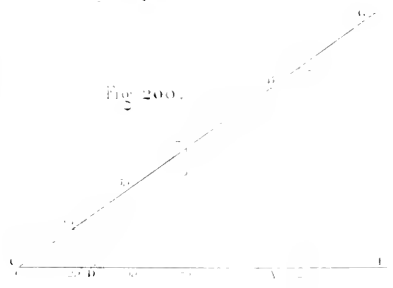

Fig. 206.

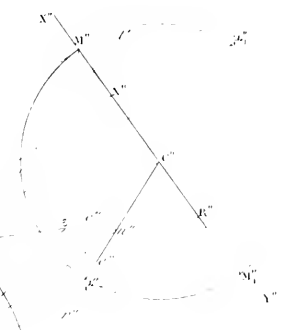
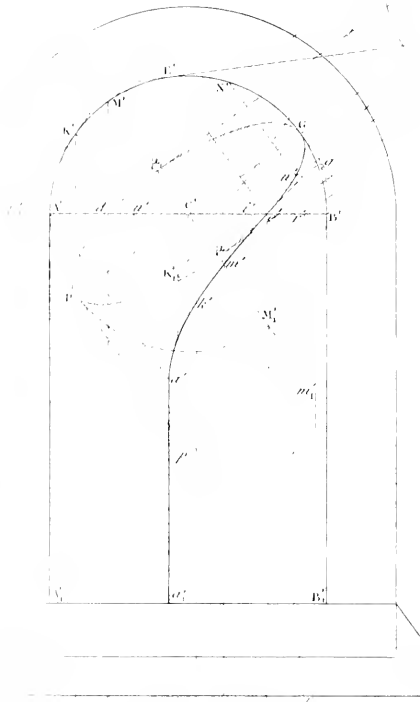

Fig. 207.

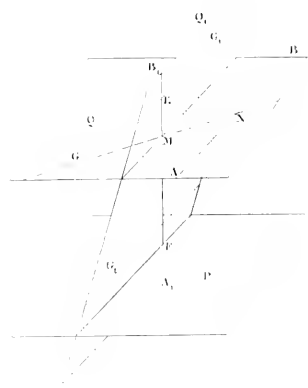

Fig. 207. a.

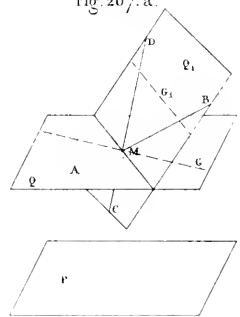

Fig. 208.

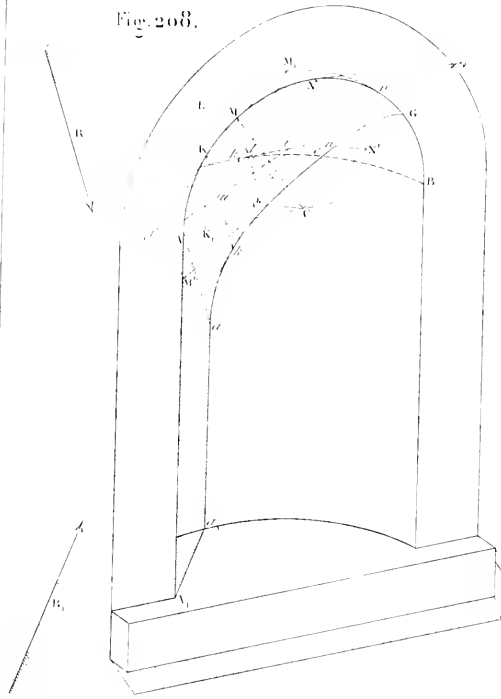

Fig. 210.

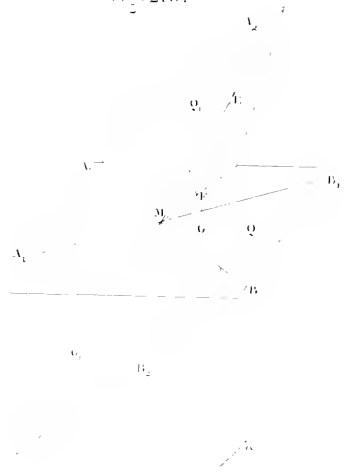

Fig. 211.

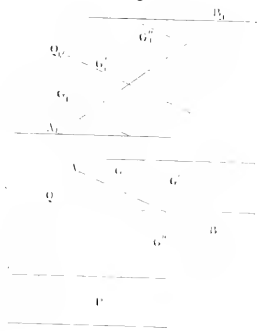

Fig. 209.

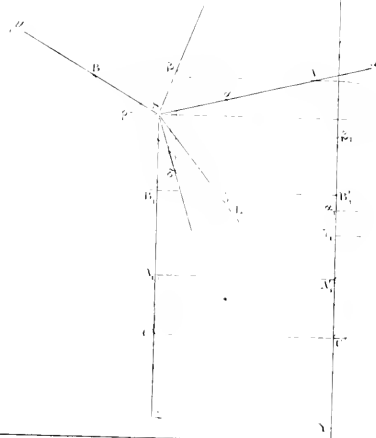

Fig. 202.

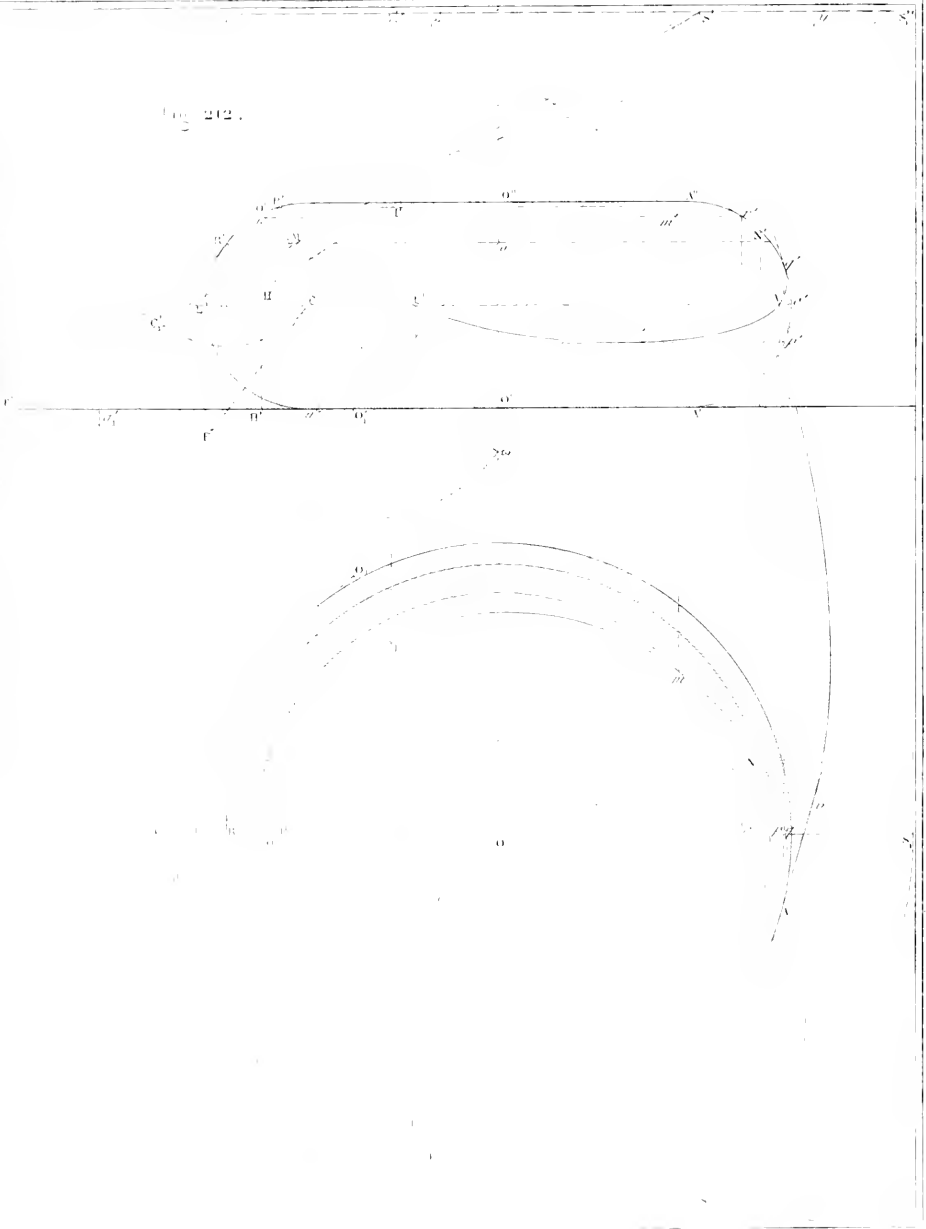

Fig. 213.

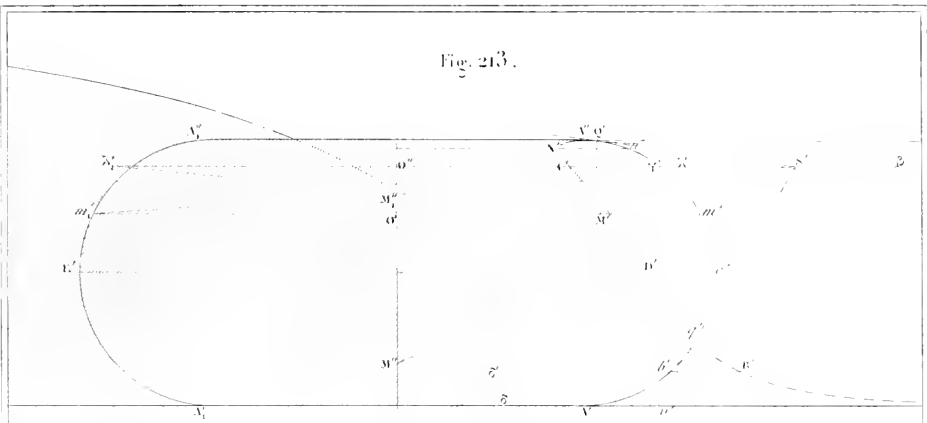
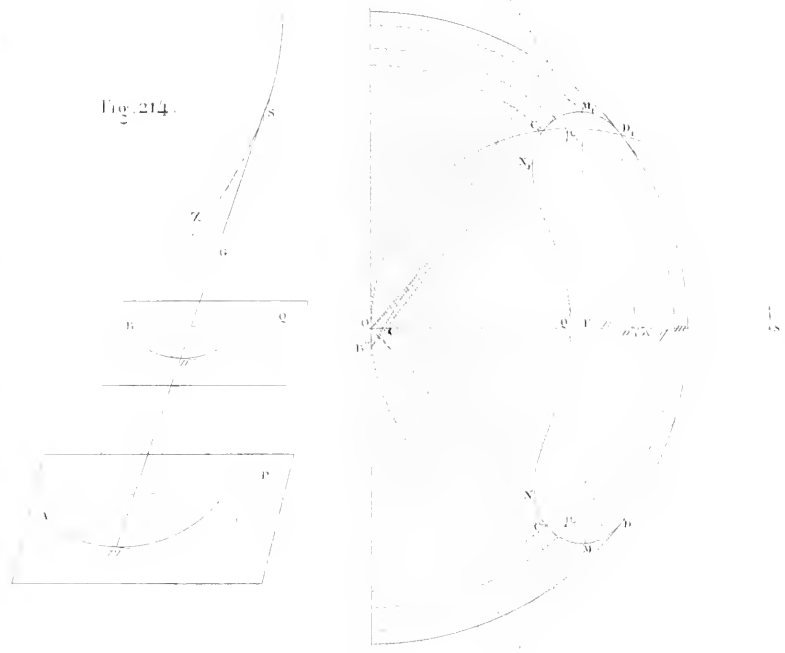
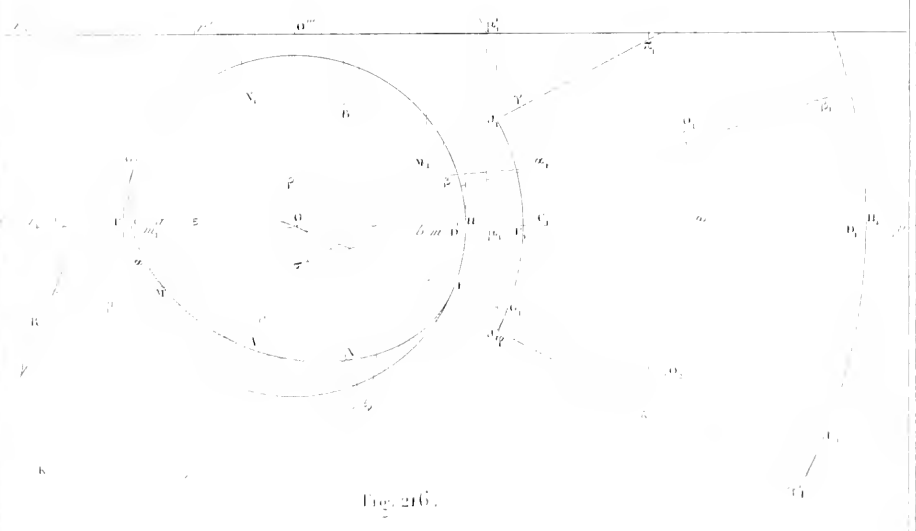
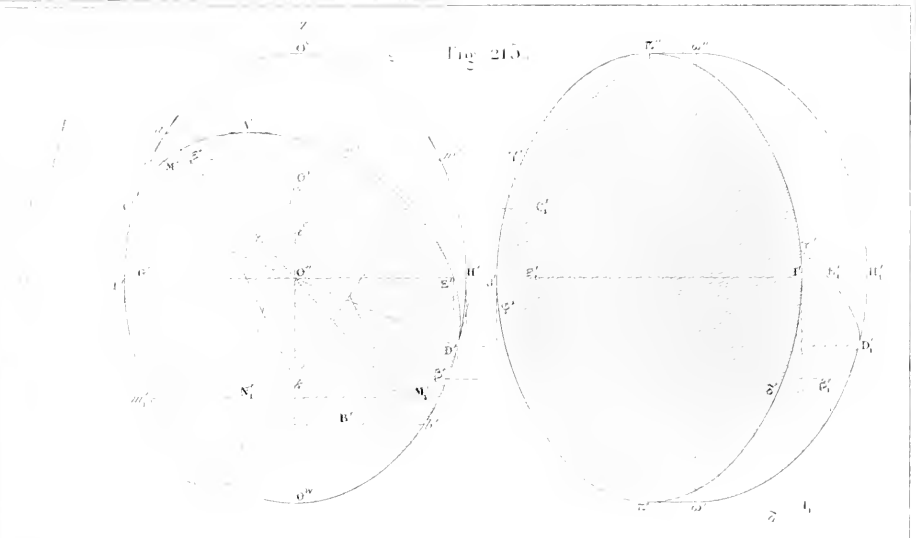

Fig. 214.





α_1 α_2 α_3 α_4 α_5 α_6 α_7 α_8 α_9 α_{10} α_{11} α_{12} α_{13} α_{14} α_{15} α_{16} α_{17} α_{18} α_{19} α_{20} α_{21} α_{22} α_{23} α_{24} α_{25} α_{26} α_{27} α_{28} α_{29} α_{30} α_{31} α_{32} α_{33} α_{34} α_{35} α_{36} α_{37} α_{38} α_{39} α_{40} α_{41} α_{42} α_{43} α_{44} α_{45} α_{46} α_{47} α_{48} α_{49} α_{50} α_{51} α_{52} α_{53} α_{54} α_{55} α_{56} α_{57} α_{58} α_{59} α_{60} α_{61} α_{62} α_{63} α_{64} α_{65} α_{66} α_{67} α_{68} α_{69} α_{70} α_{71} α_{72} α_{73} α_{74} α_{75} α_{76} α_{77} α_{78} α_{79} α_{80} α_{81} α_{82} α_{83} α_{84} α_{85} α_{86} α_{87} α_{88} α_{89} α_{90} α_{91} α_{92} α_{93} α_{94} α_{95} α_{96} α_{97} α_{98} α_{99} α_{100}

Fig. 217.

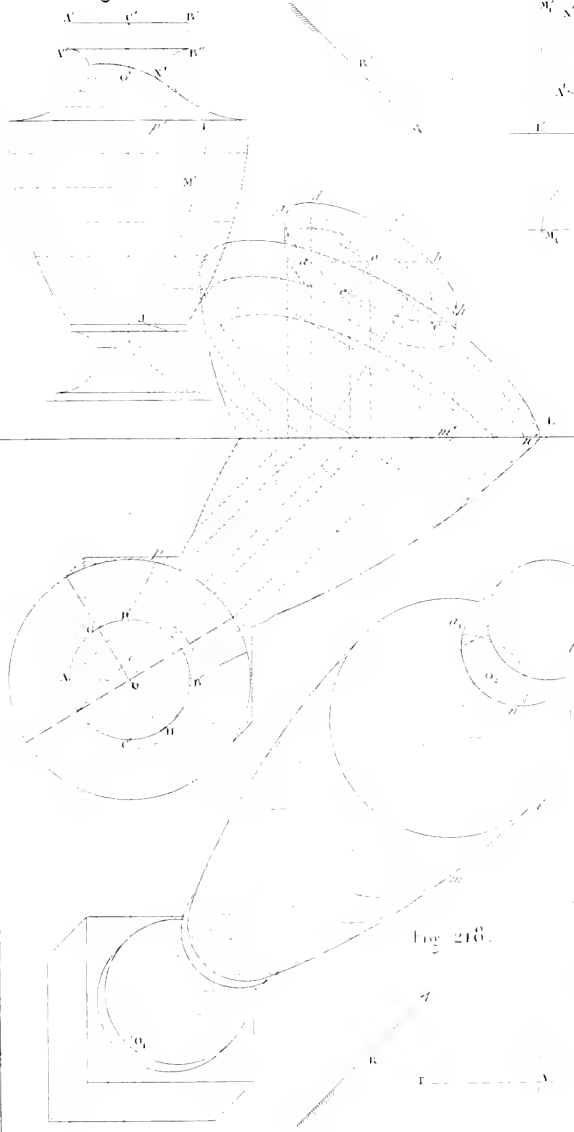

Fig. 220.

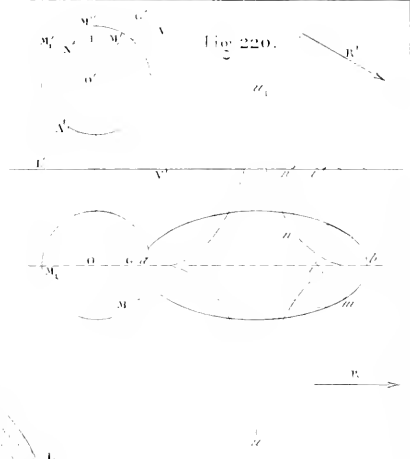

Fig. 210.

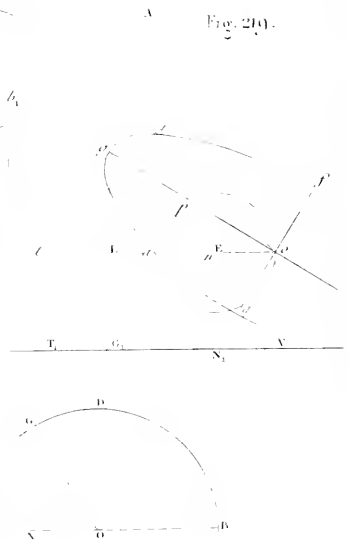

Fig. 210.



Fig. 221.

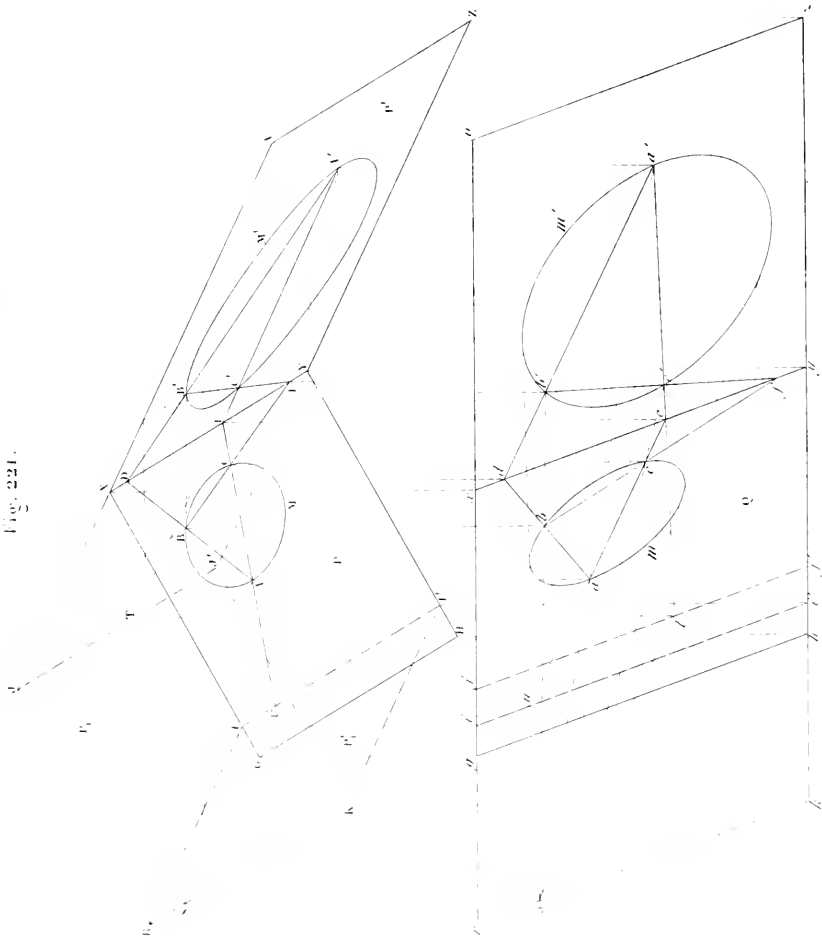

Fig. 222.

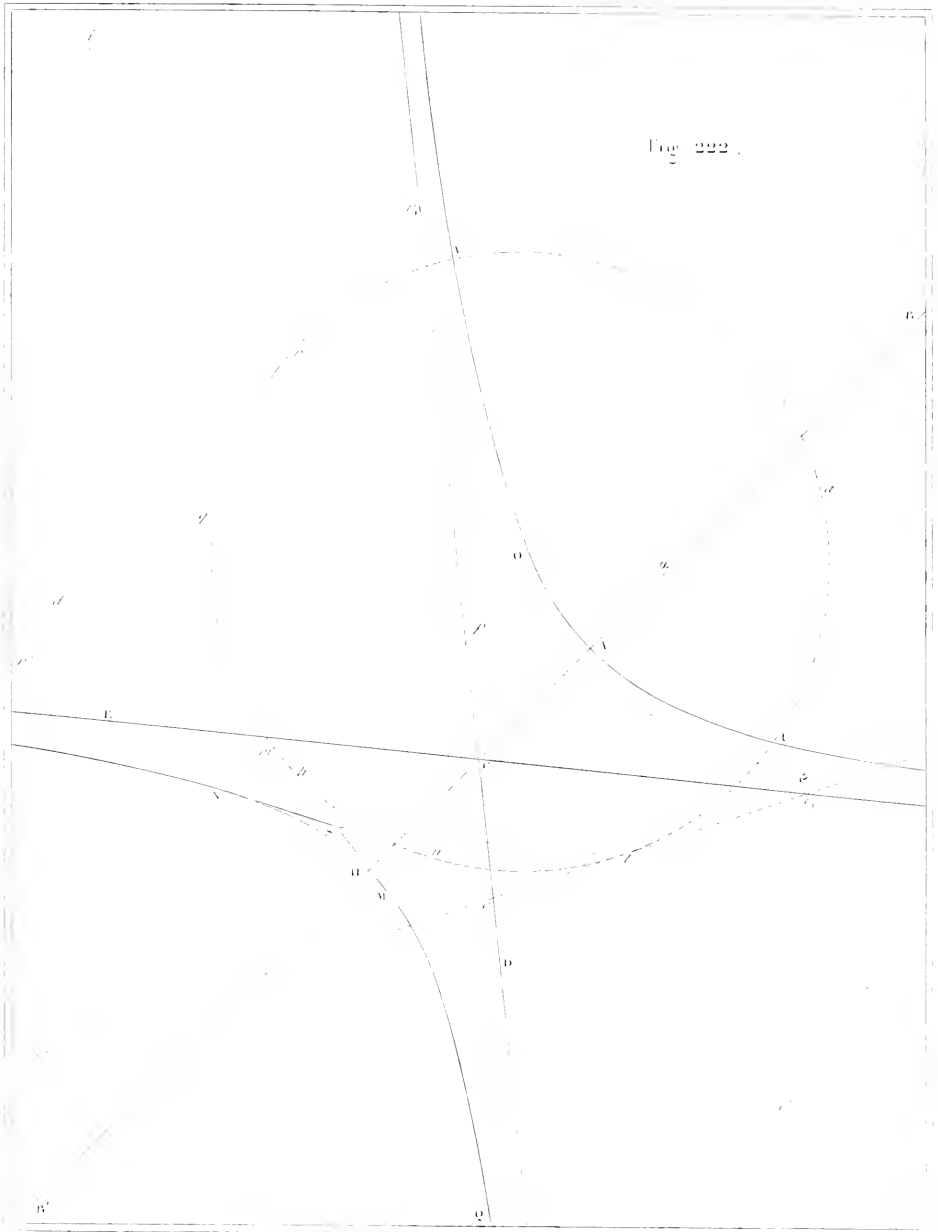

Fig. 223.

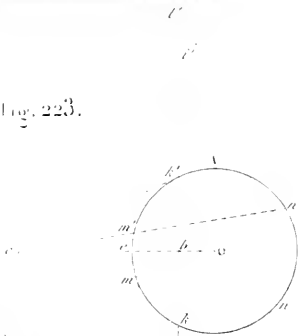

Fig. 224.

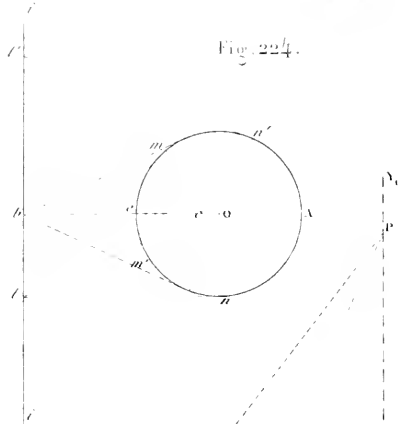

Fig. 225.

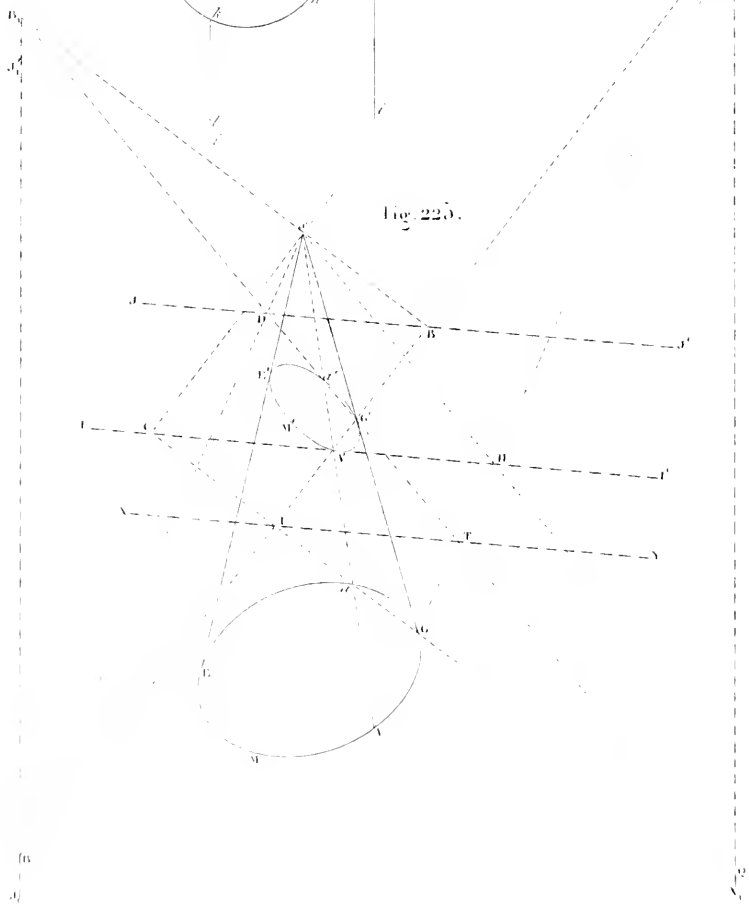

Fig. 226.

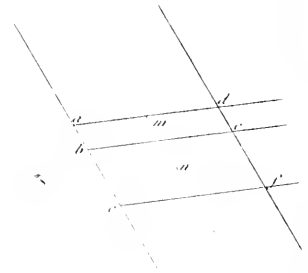
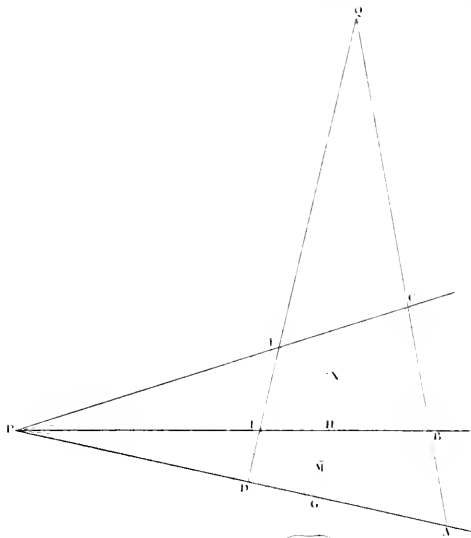

Fig. 227.

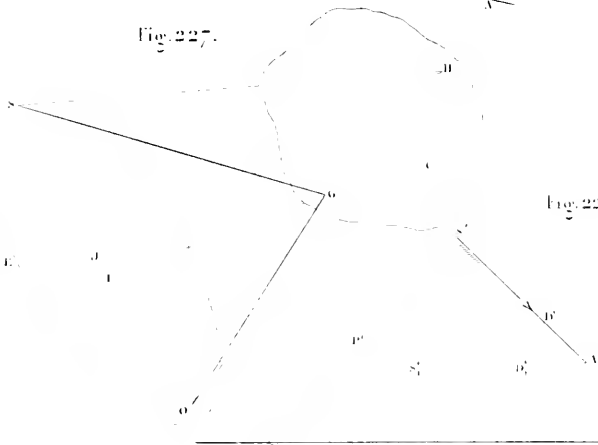

Fig. 228.

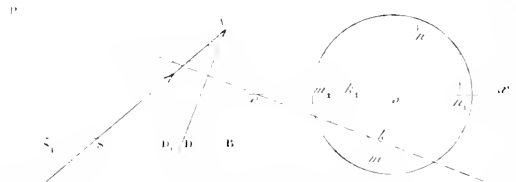
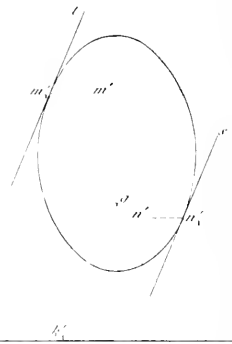

Fig. 229.

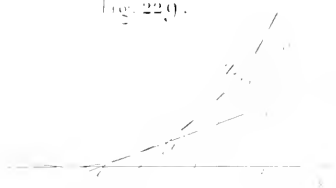

Fig. 231.

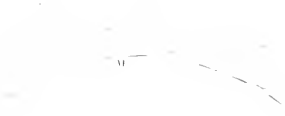

Fig. 233.

Fig. 230.

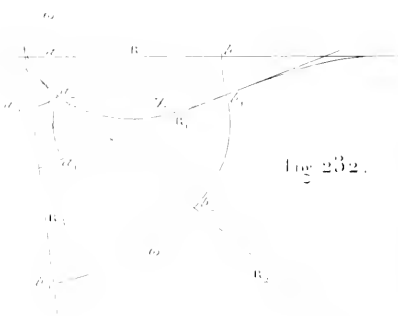
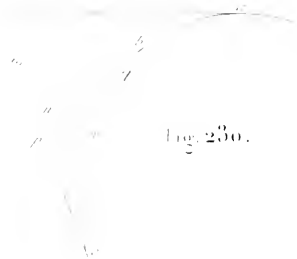

Fig. 232.



Fig. 235.

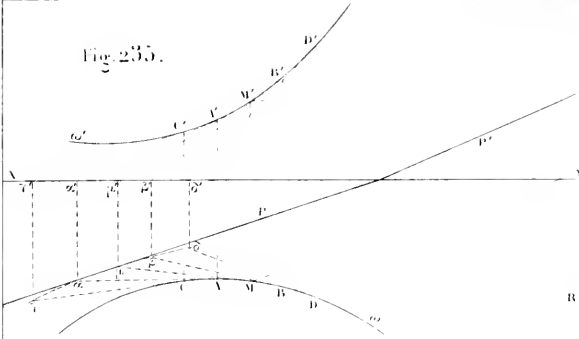

Fig. 236.

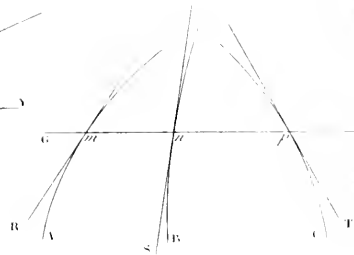

Fig. 237.

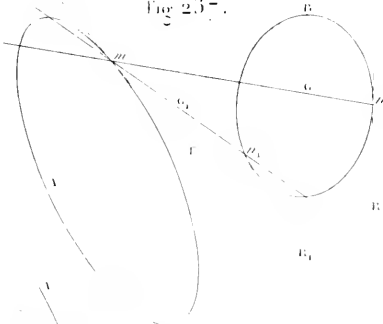

Fig. 238.

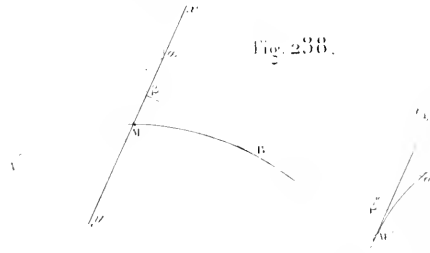

Fig. 239.

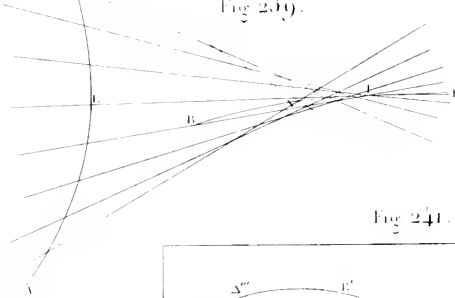

Fig. 240.

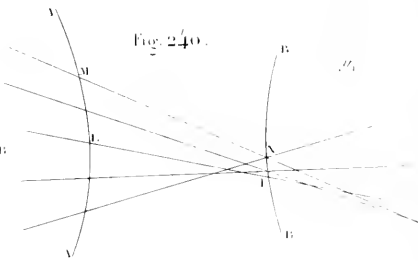

Fig. 241.

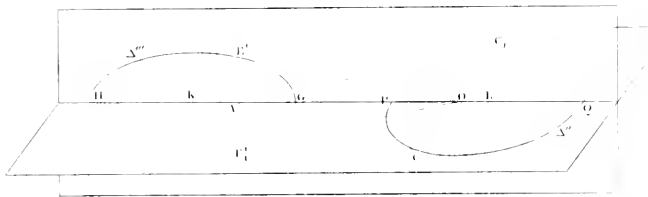

Fig. 242.

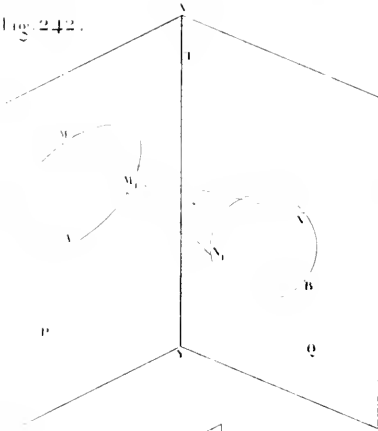

Fig. 243.

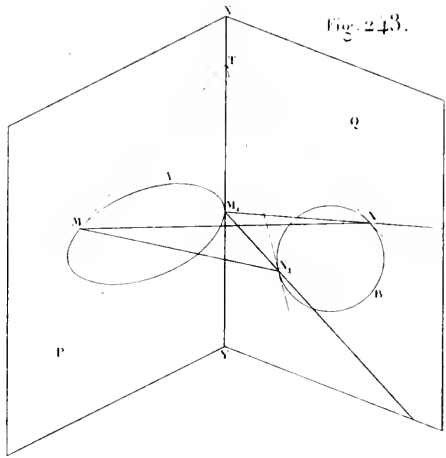

Fig. 244.

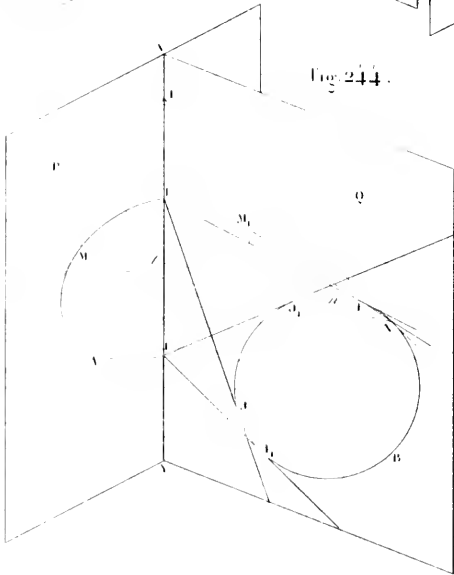

Fig. 245.

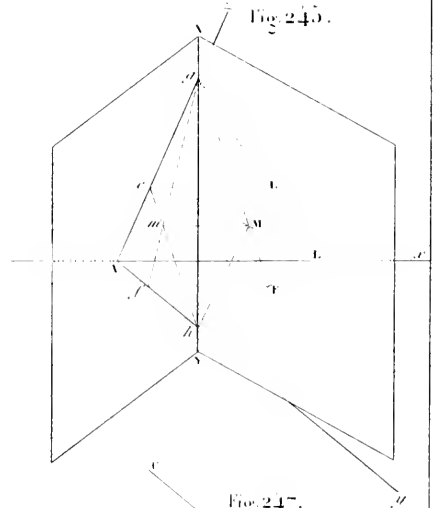

Fig. 246.



Fig. 247.

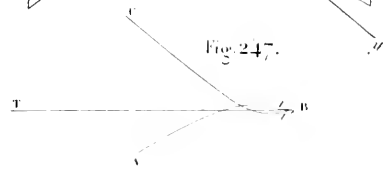

Fig. 248.

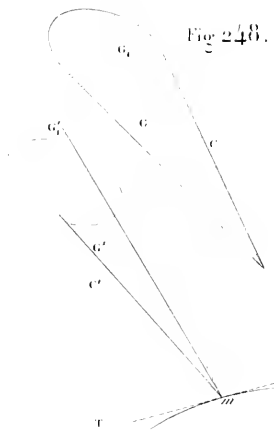

Fig. 249.

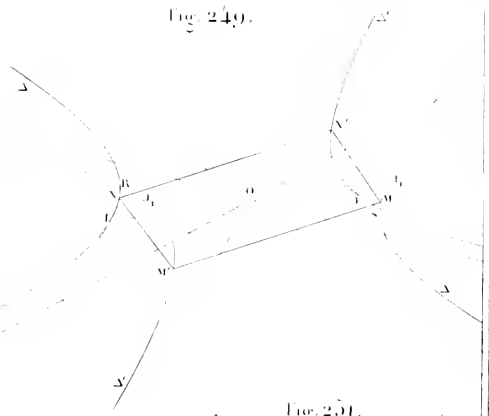

Fig. 250.

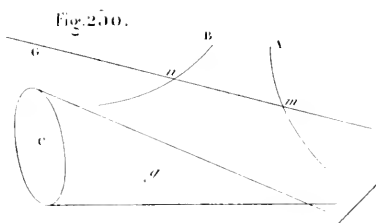

Fig. 251.

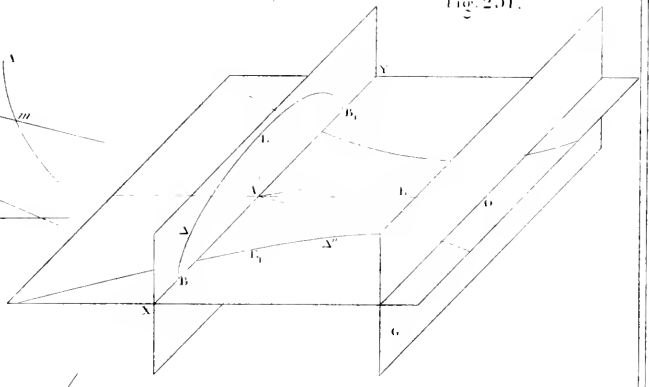

Fig. 252.

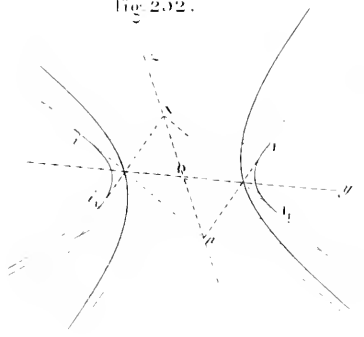

Fig. 253.

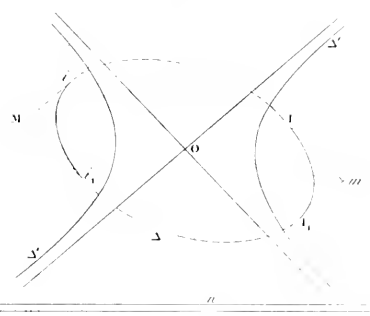

Fig. 254.



Fig. 255.

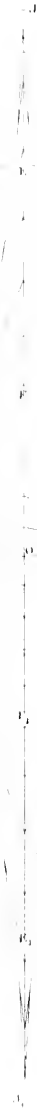
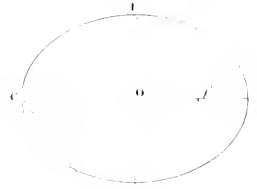

Fig. 256.



D.

C.

O.

F.

E.

B₁.

B.

257.

B.

Fig. 258.



Fig. 259.

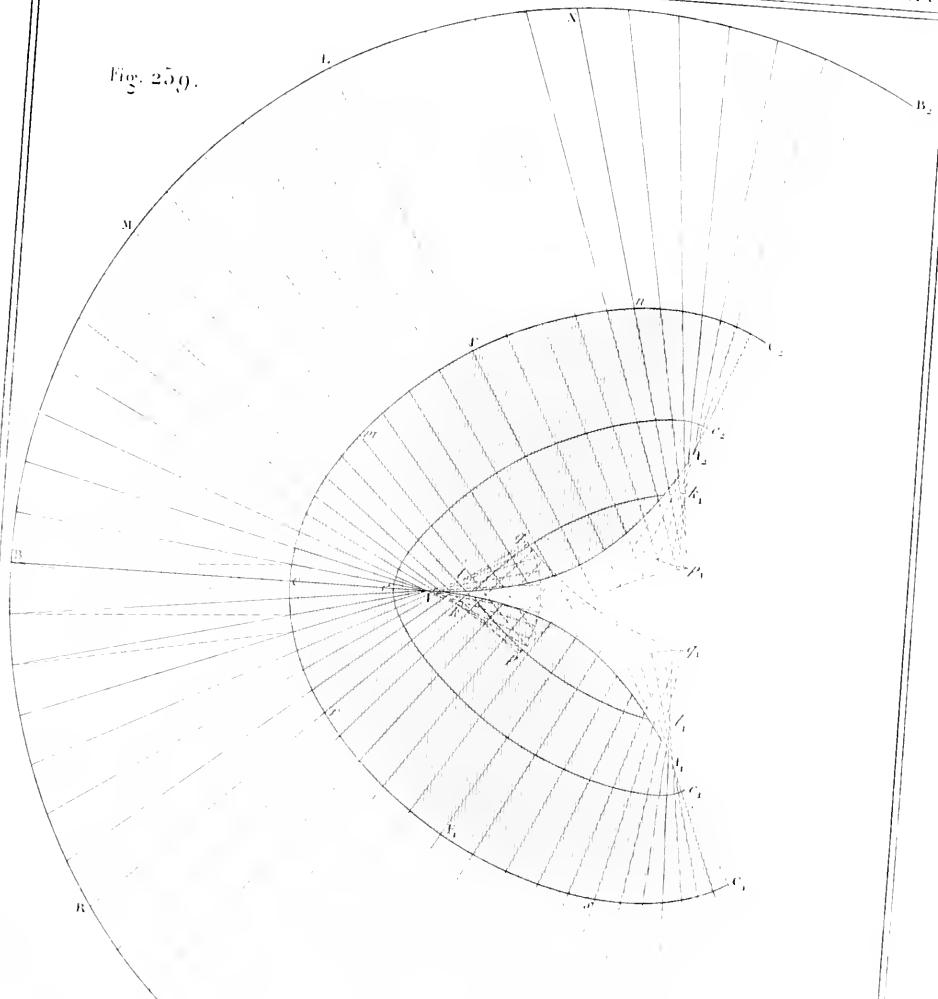
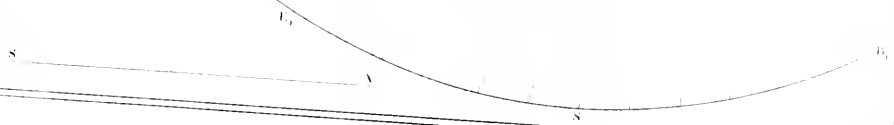

Fig. 260.



ϵ' ϵ_1 ϵ_2

Fig. 202.

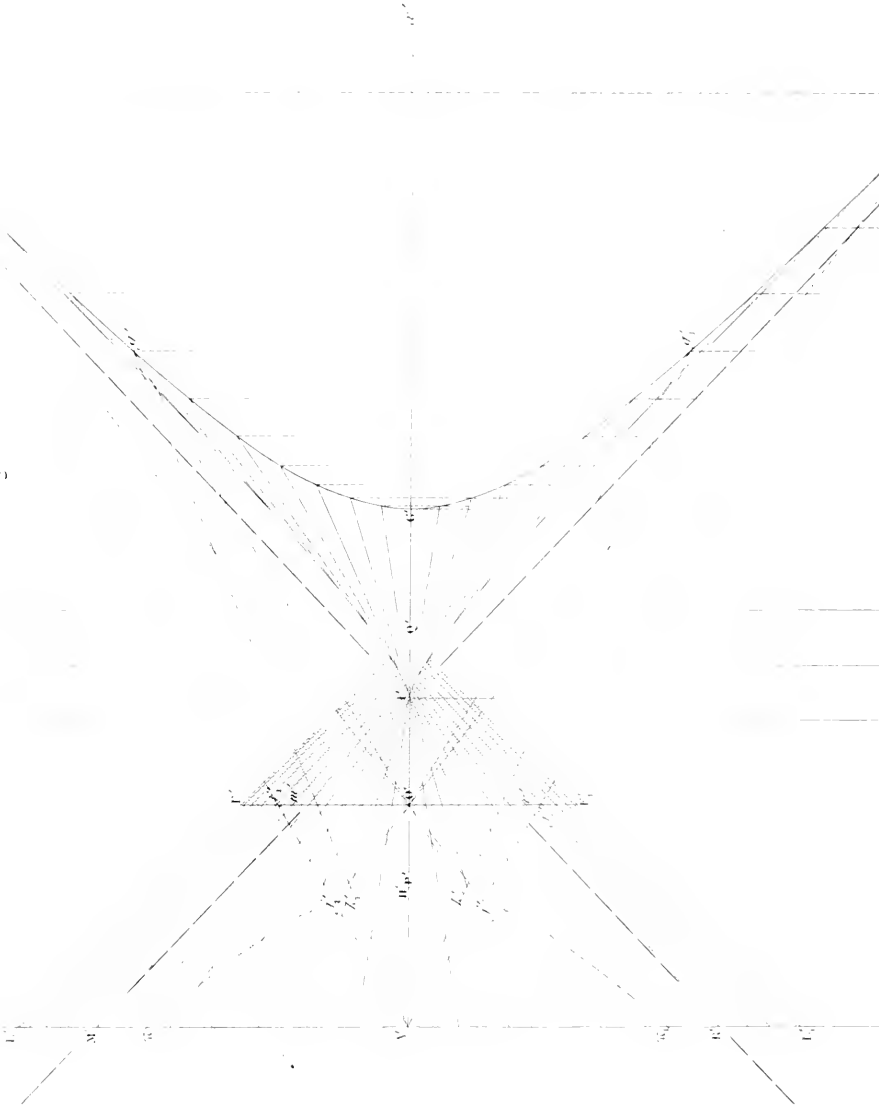

Fig. 264.

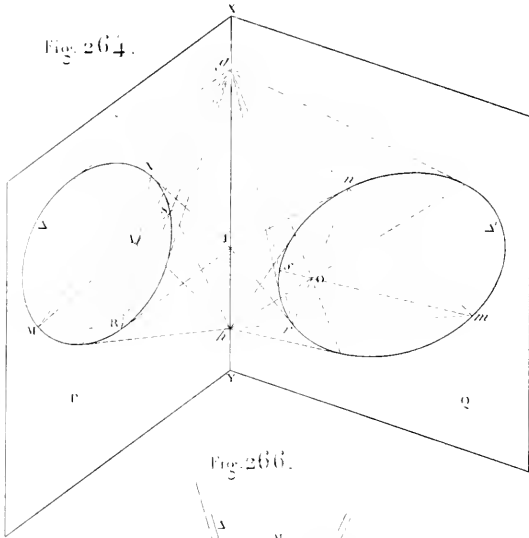

Fig. 265.

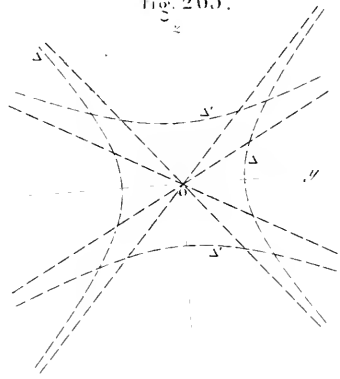

Fig. 266.

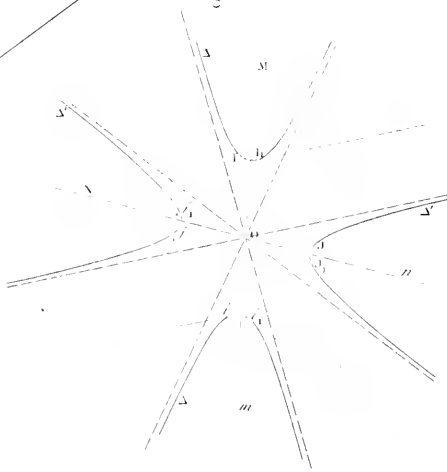

Fig. 267.

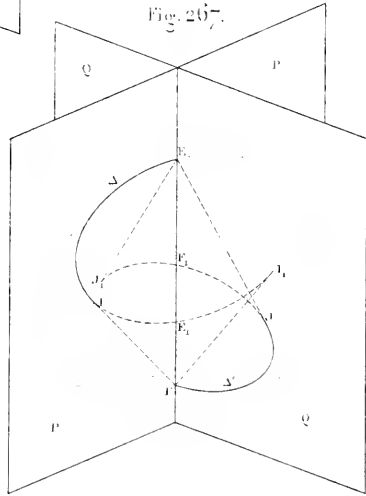

Fig. 268.

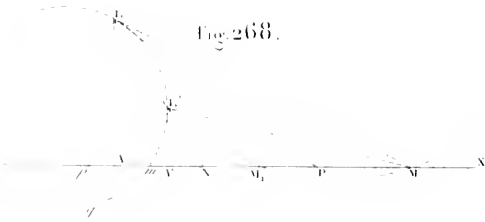

Fig. 269.

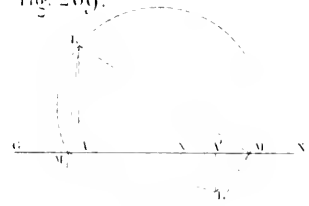

Fig. 270.

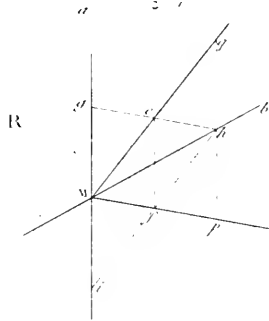

Fig. 271.

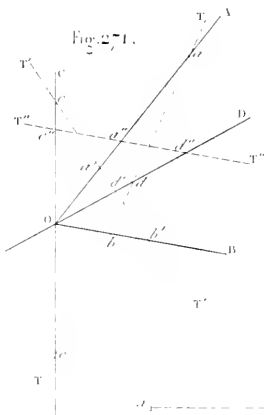

Fig. 272.

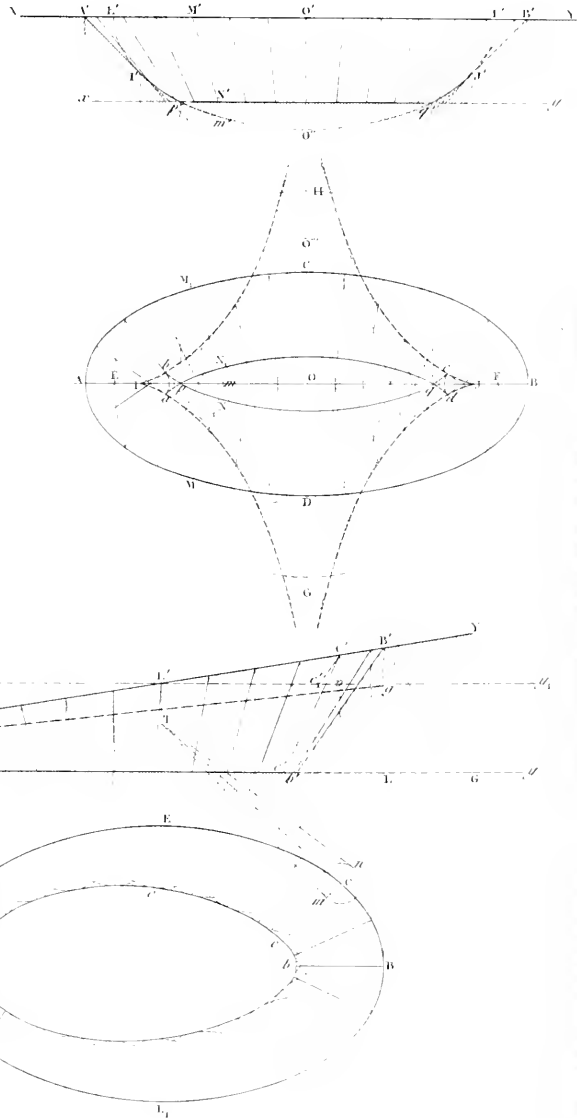

Fig. 273.

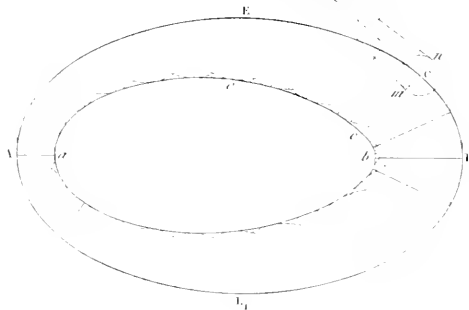



Fig. 270.

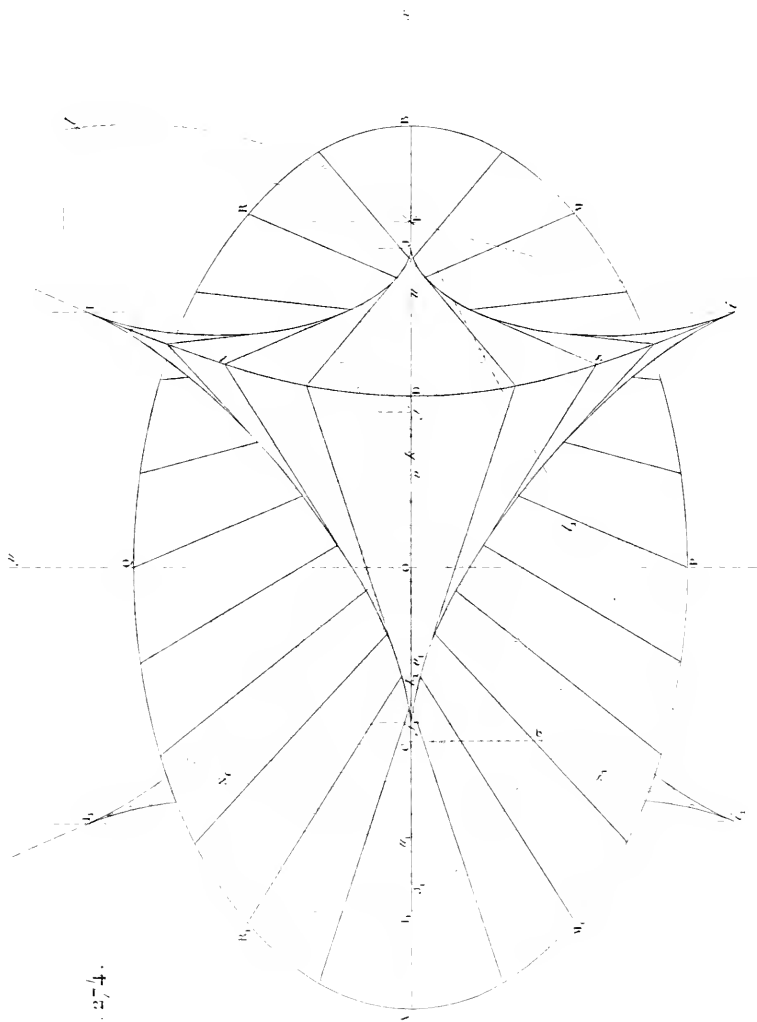
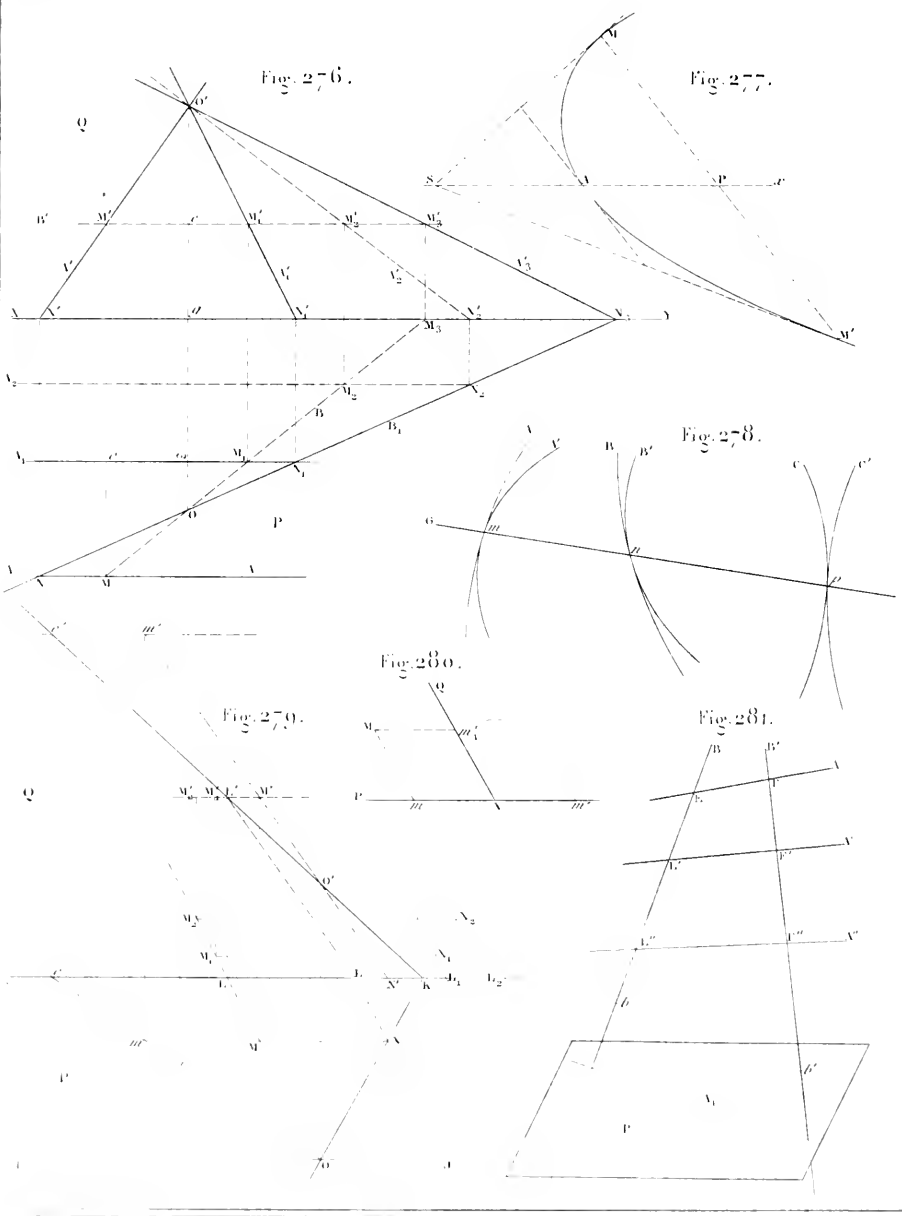

Fig. 274.



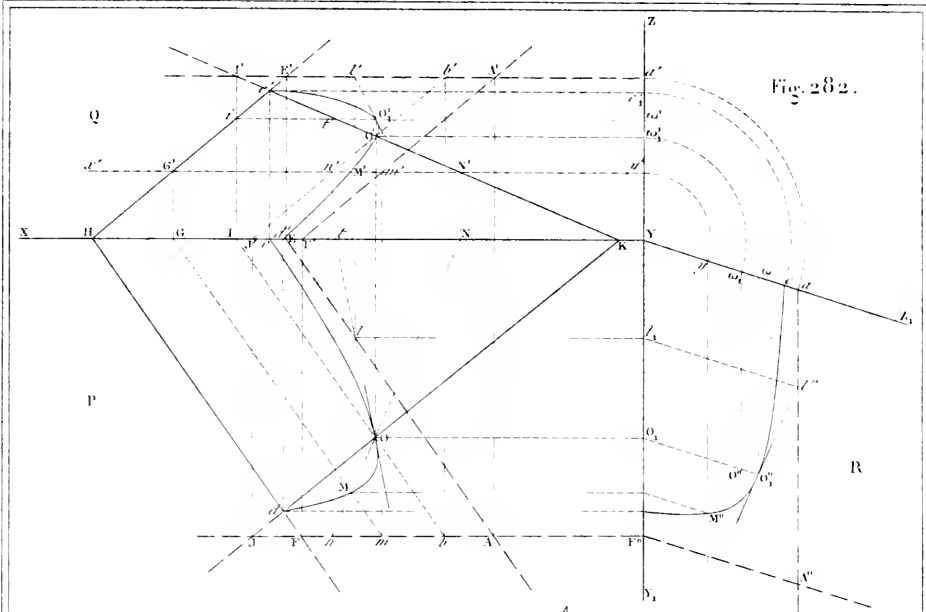

Fig. 282.

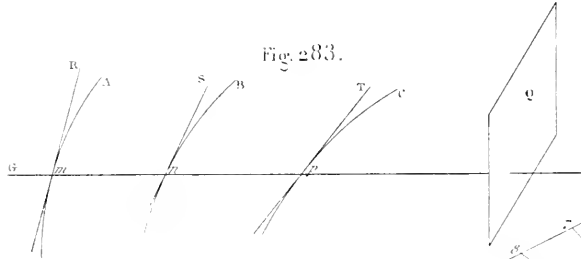

Fig. 283.

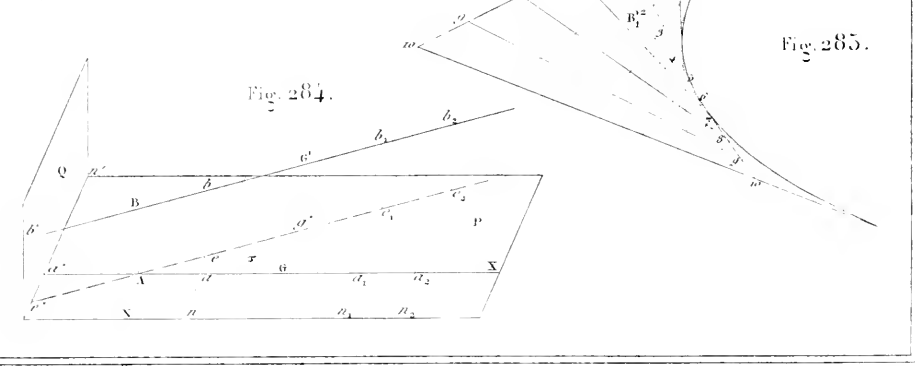

Fig. 284.

Fig. 285.

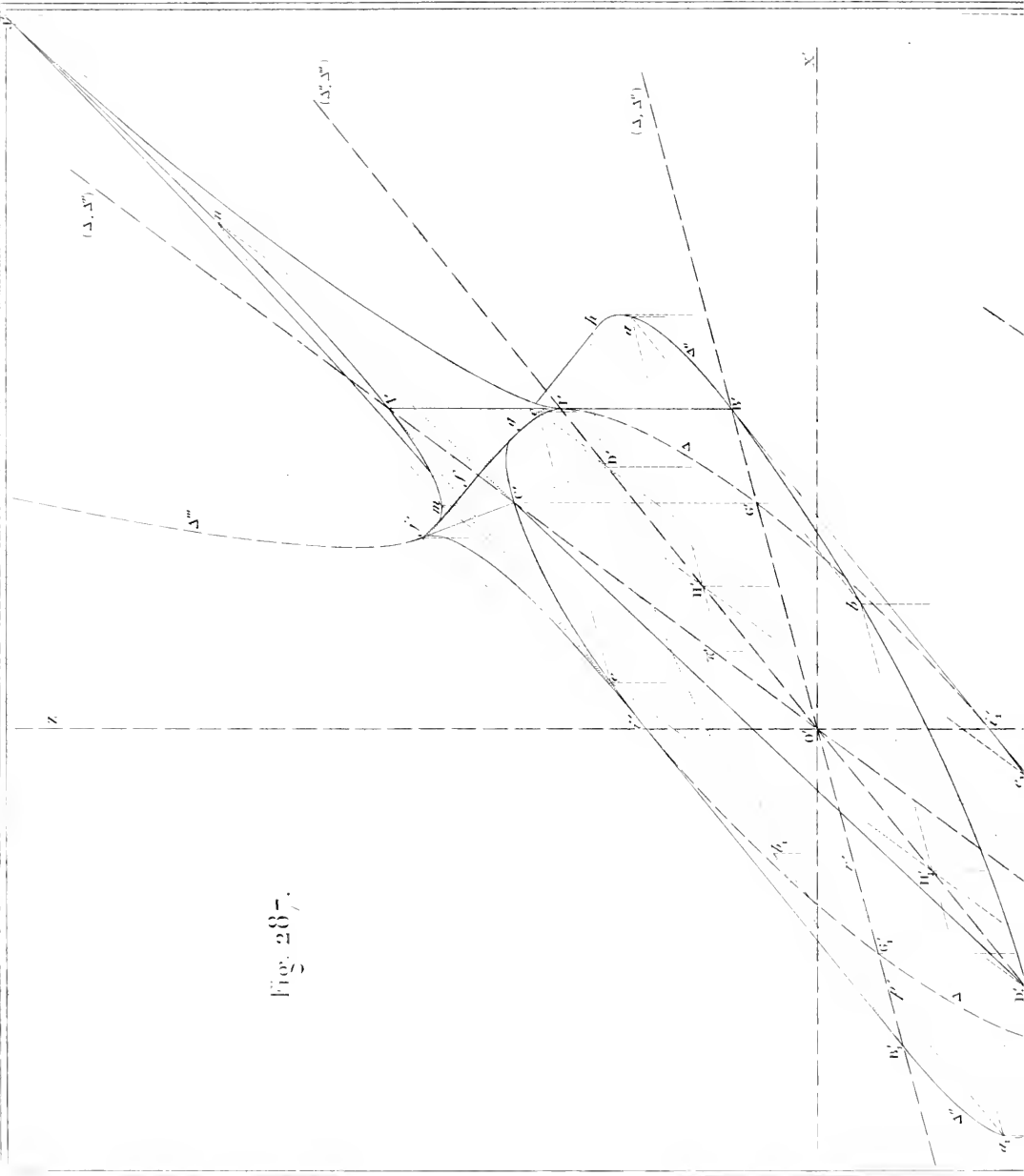

Fig. 287.

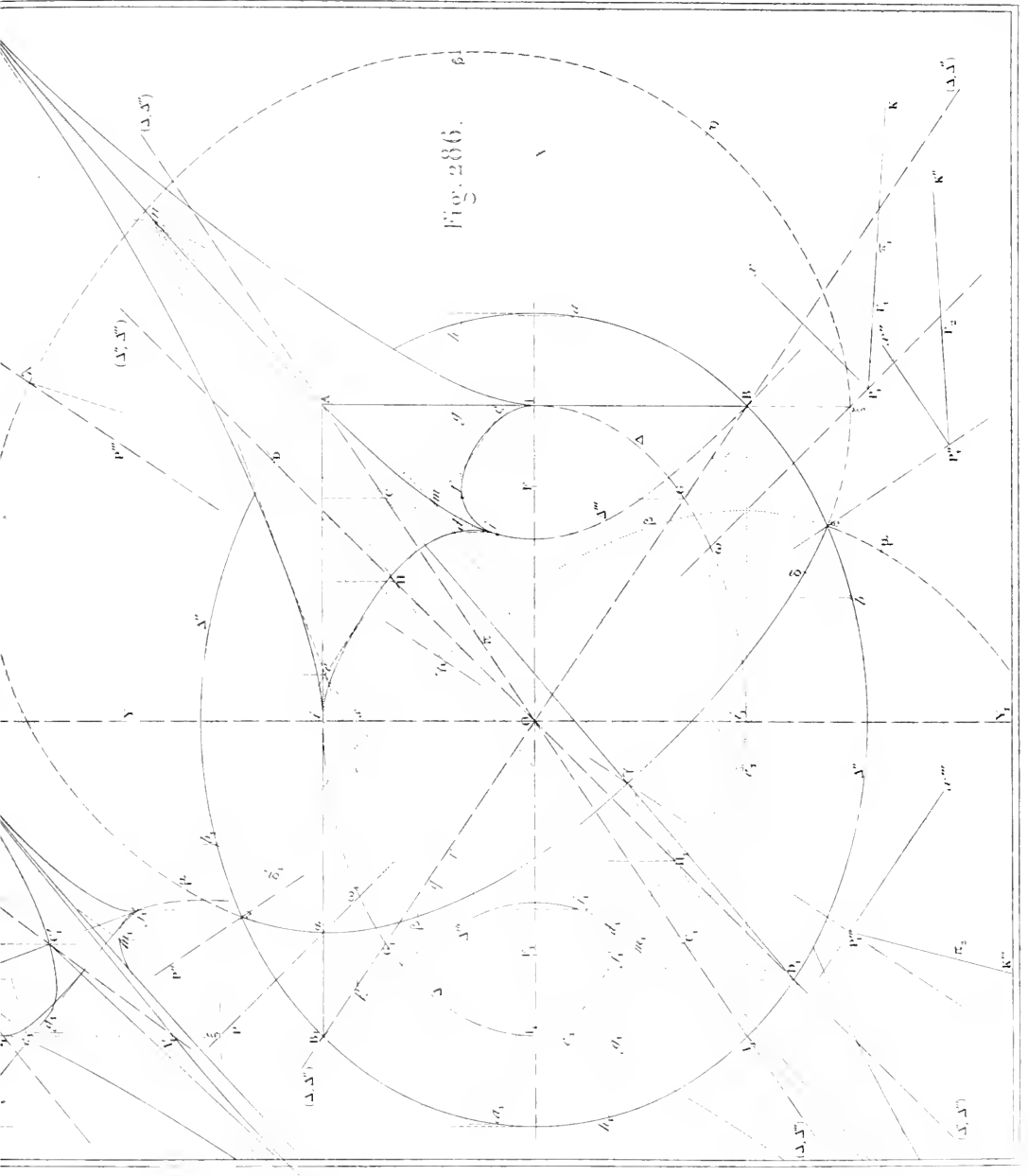

Fig. 286.

α'

α''

Fig. 283.

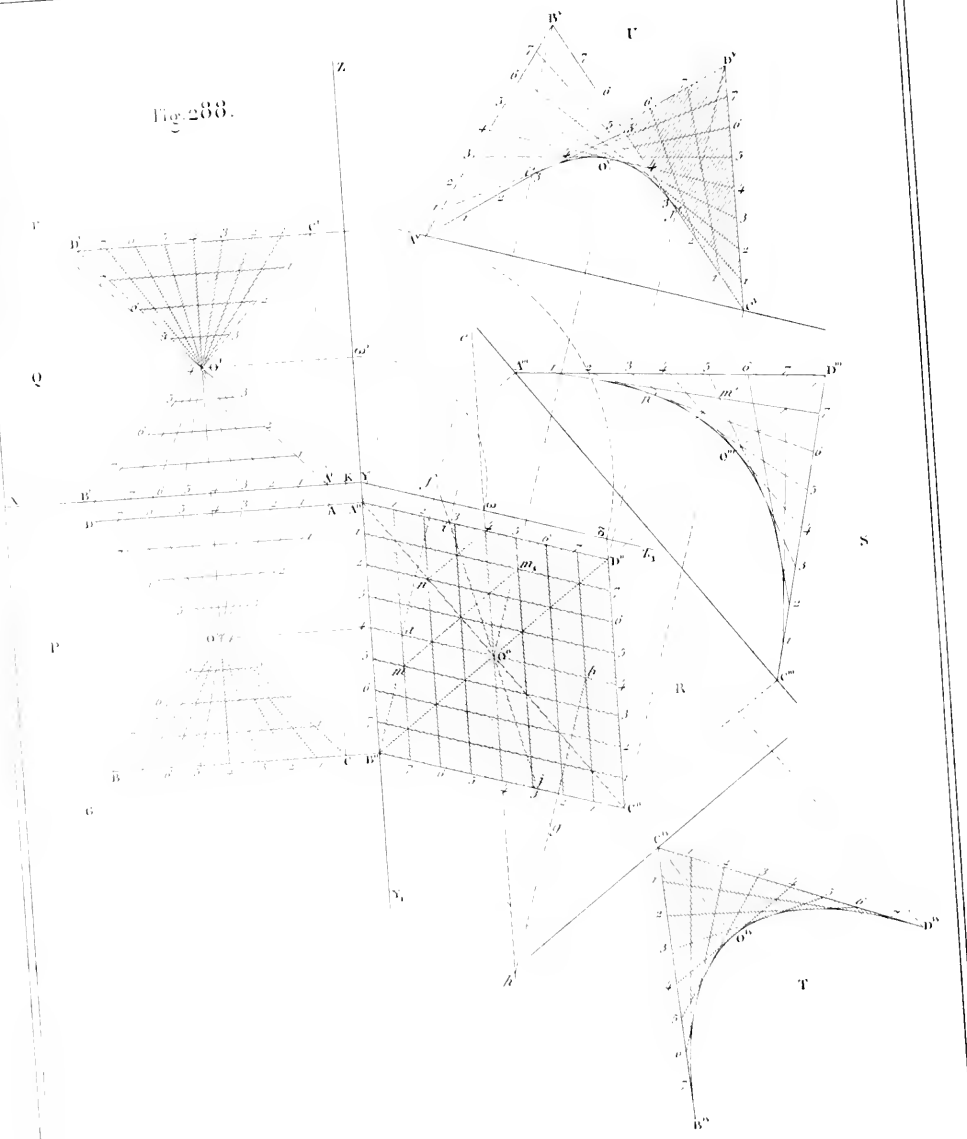

Fig 200.

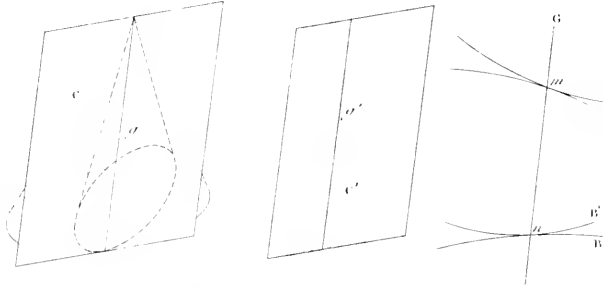

Fig. 200.

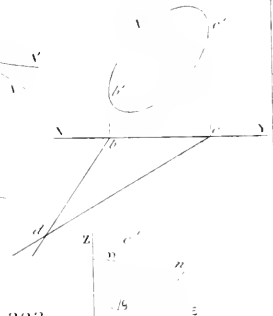

Fig 201.

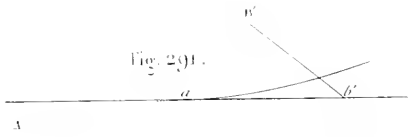

Fig 202.



Fig 203.

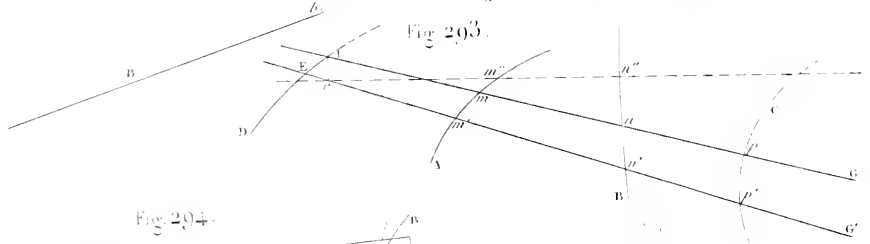

Fig 204.

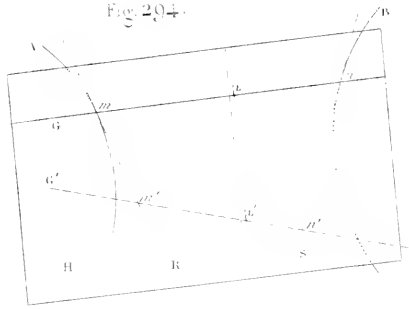

Fig 205.

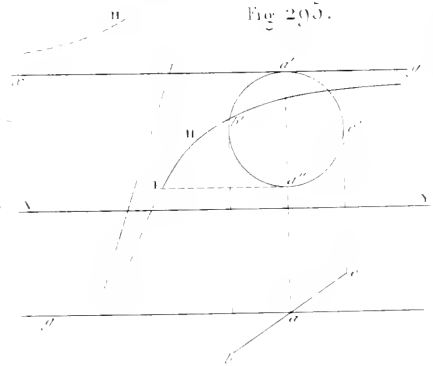
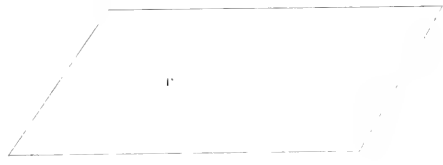
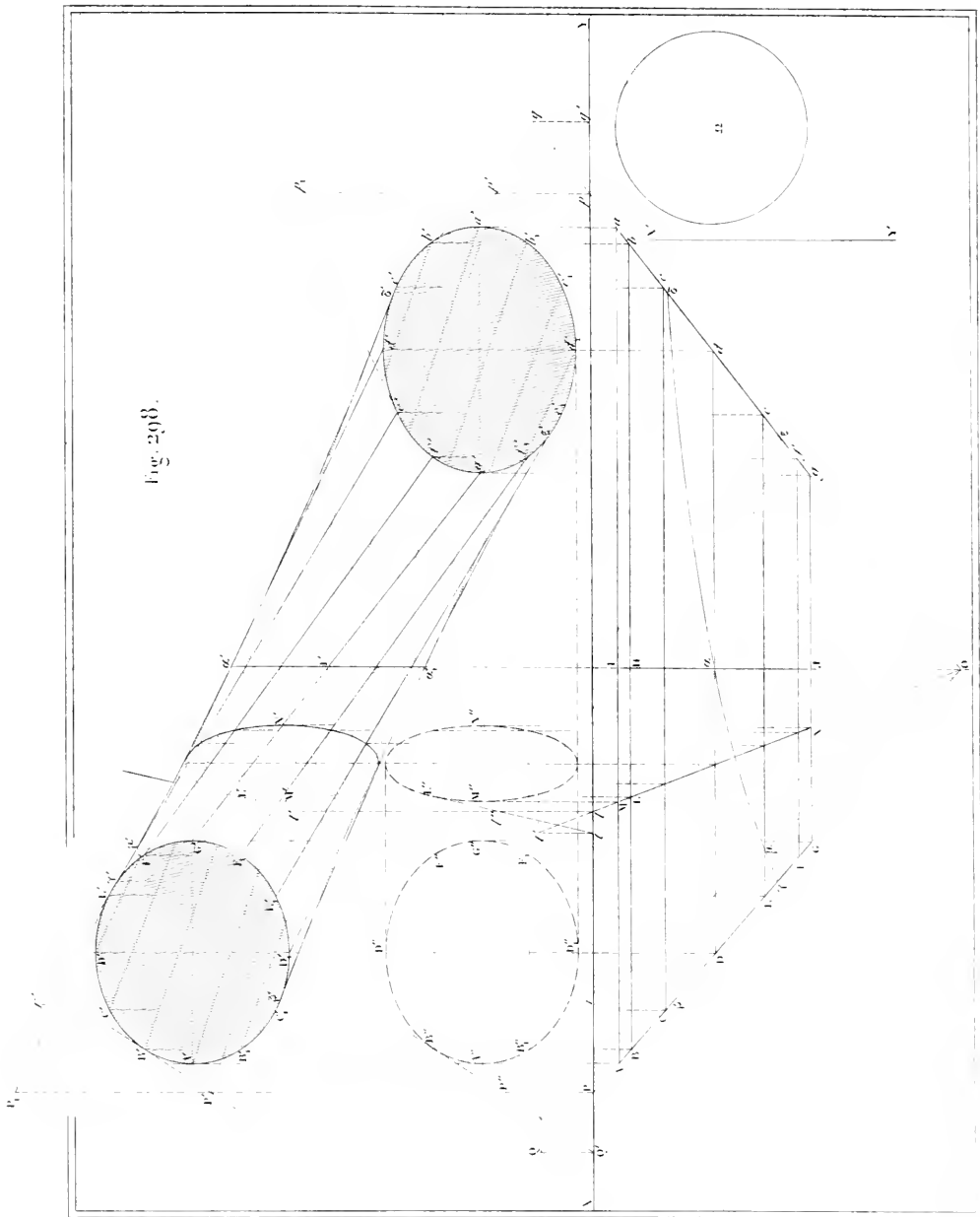
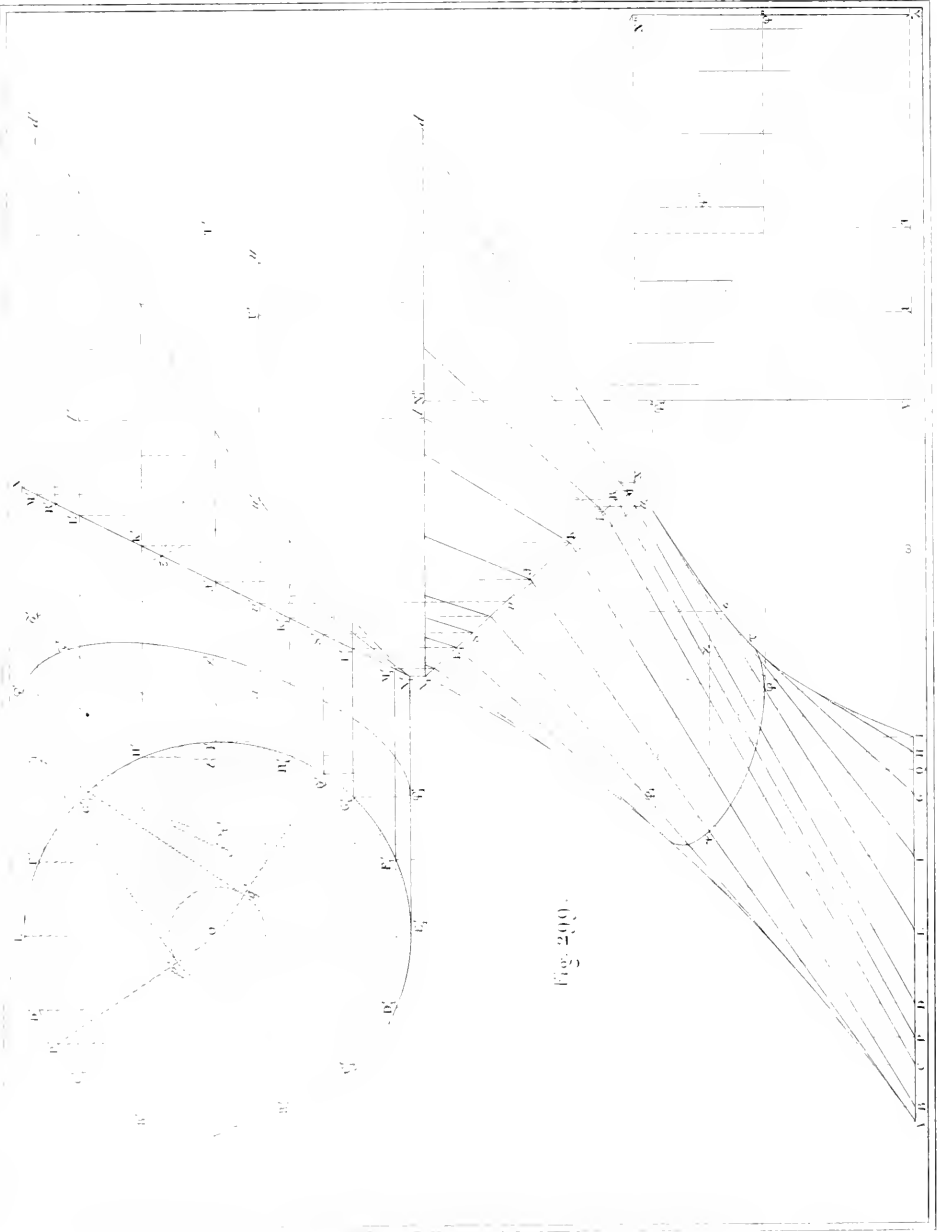

Fig. 208.





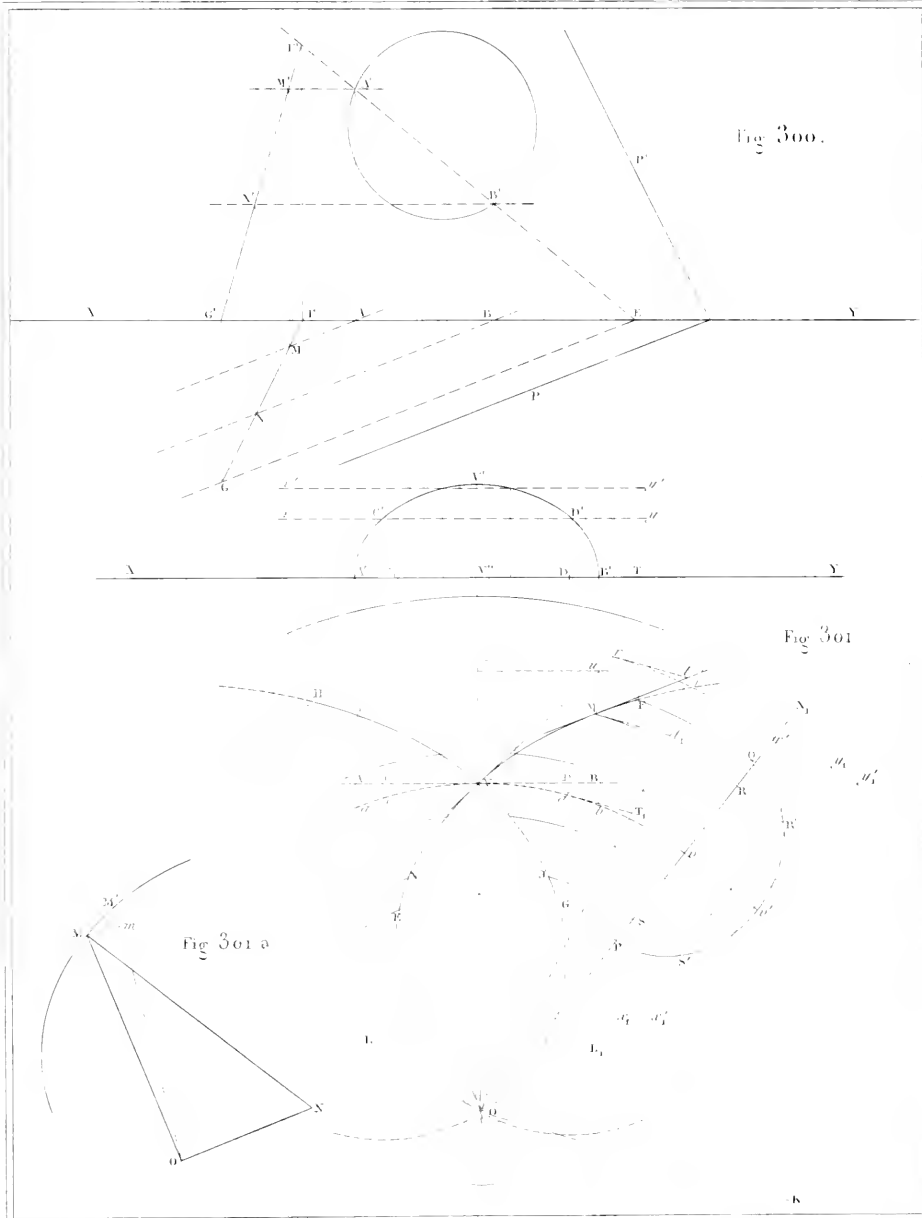

Fig 300.

Fig 301

Fig 301 a

Fig. 306.

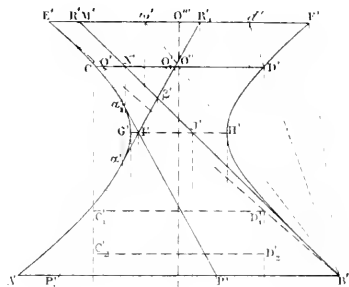

Fig. 307.

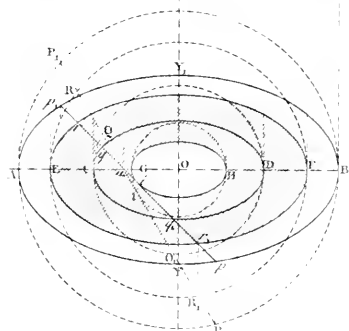
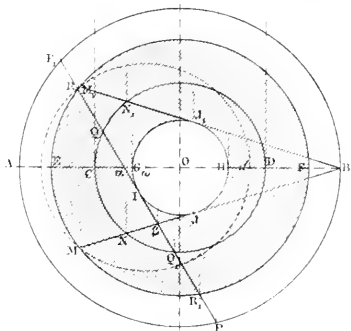
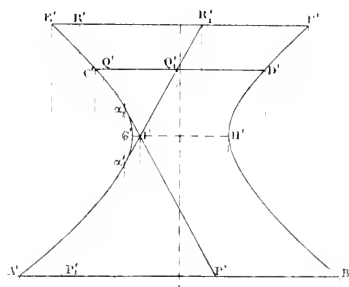

Fig. 308.

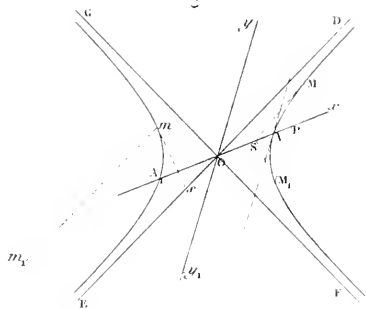
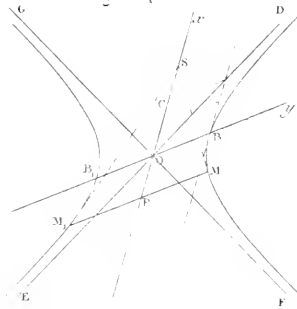

Fig. 309.



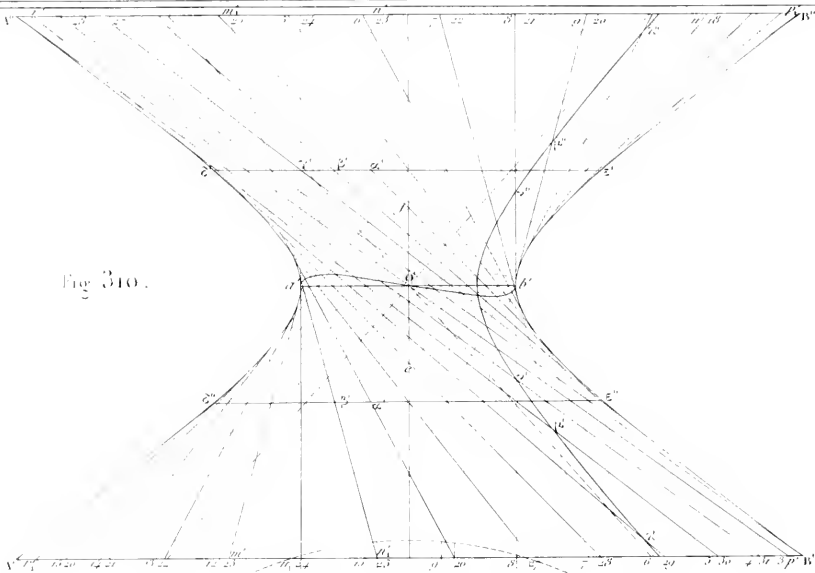
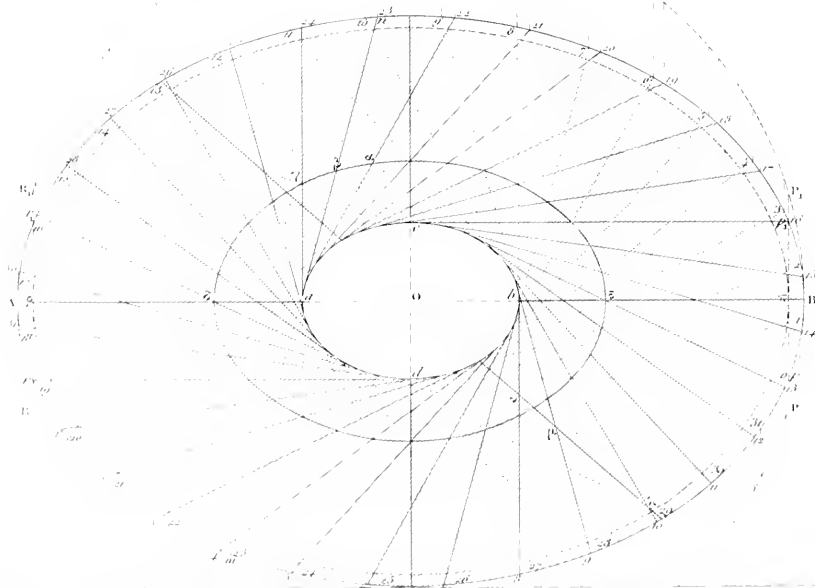

Fig. 310.



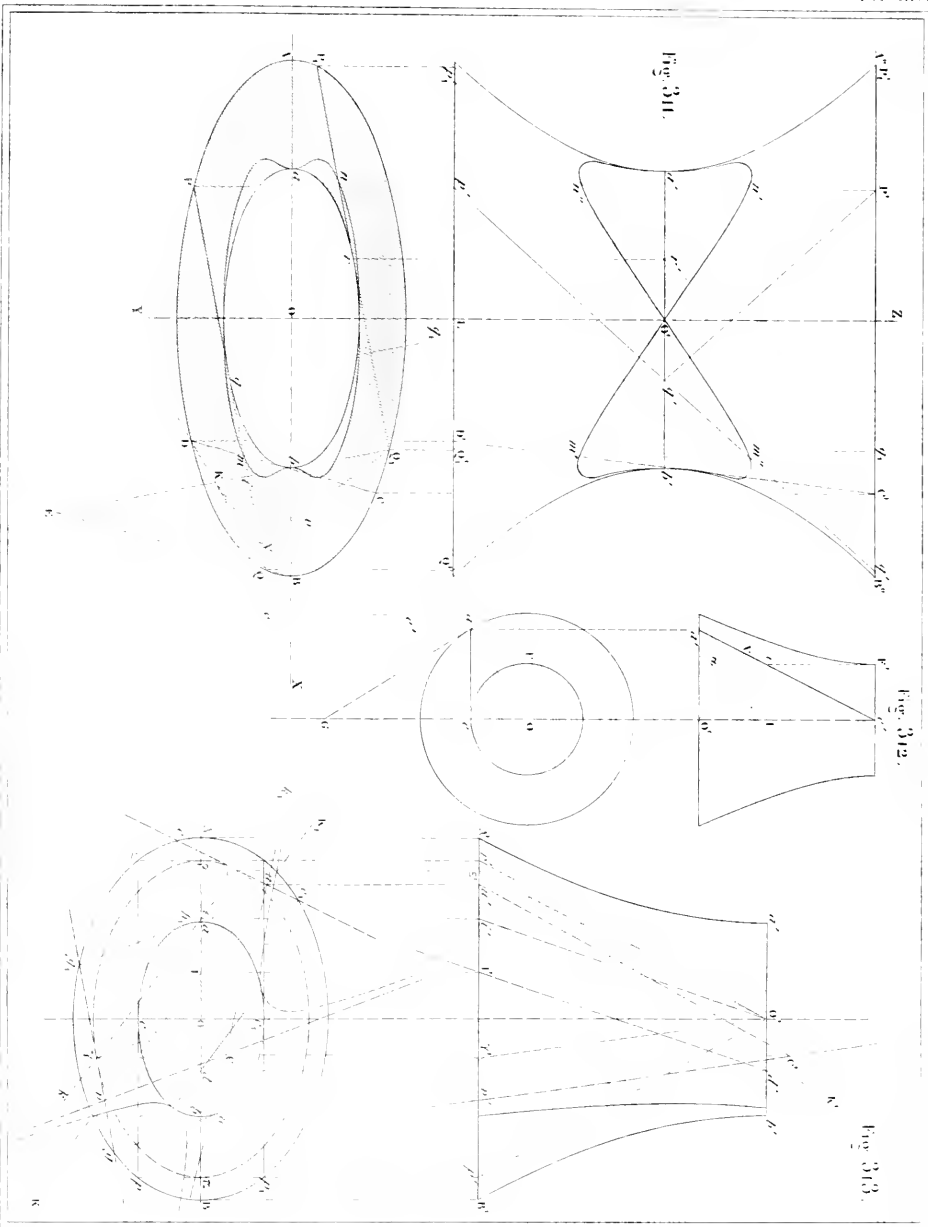
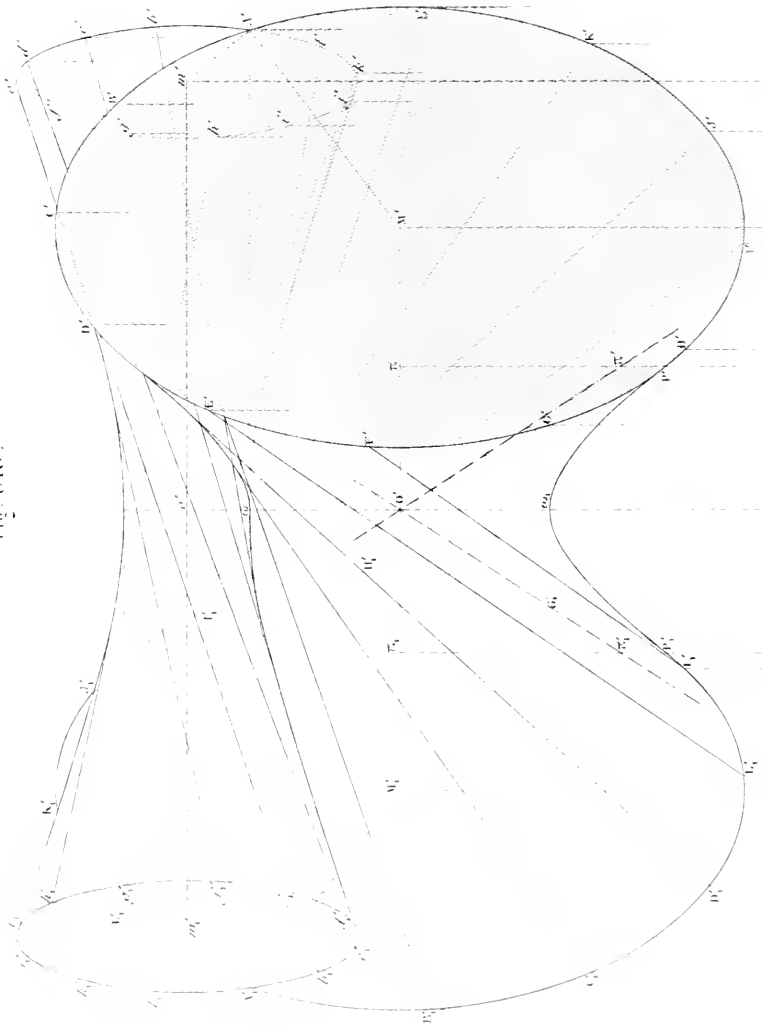

Fig. 365.



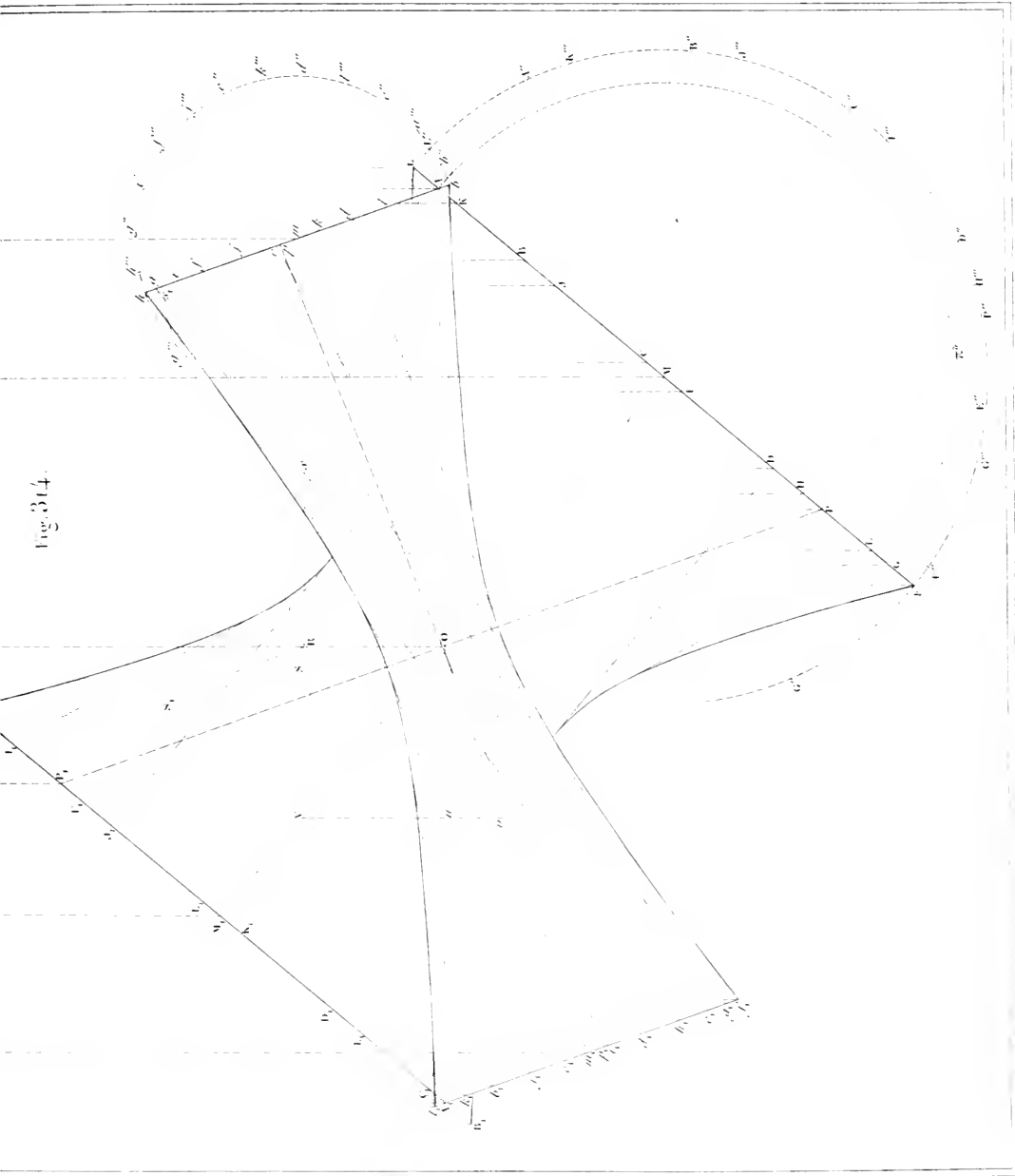

Fig. 316.

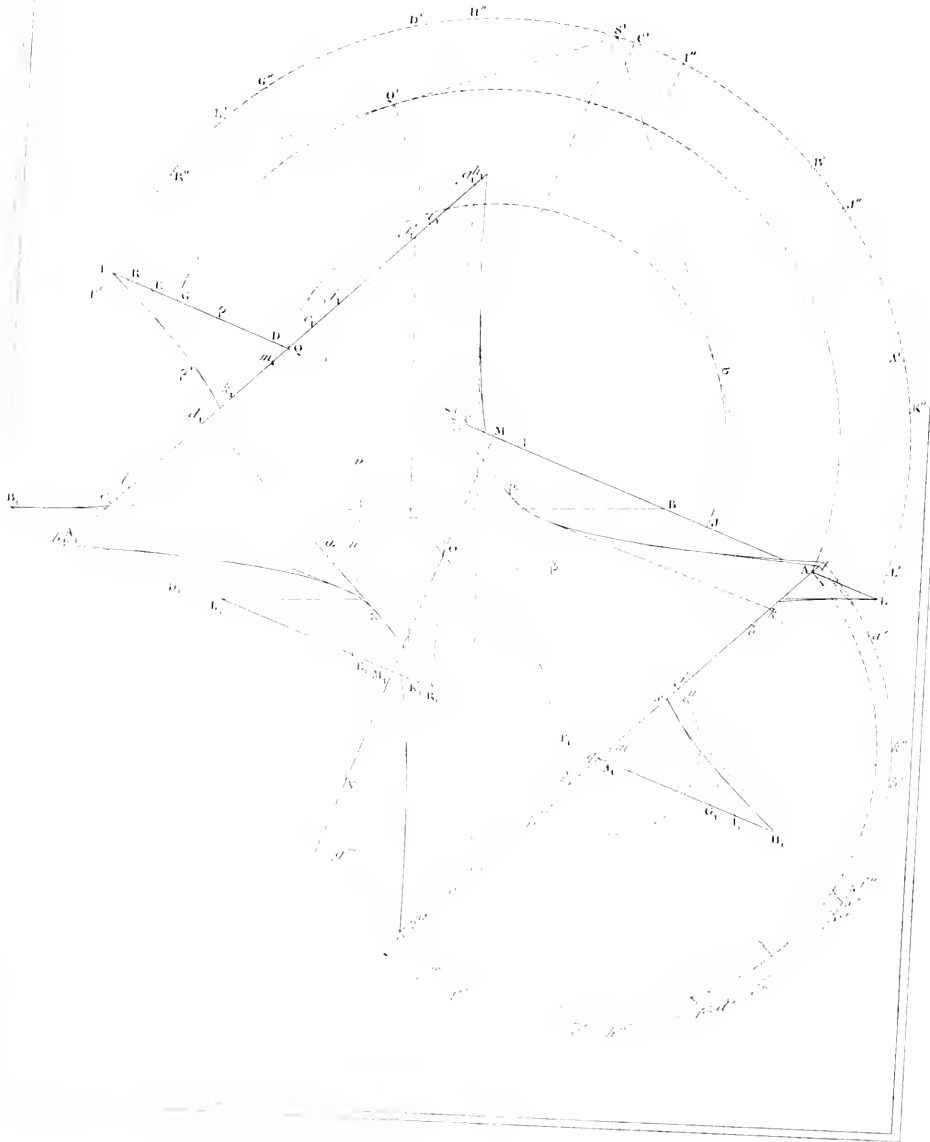

Fig. 317.

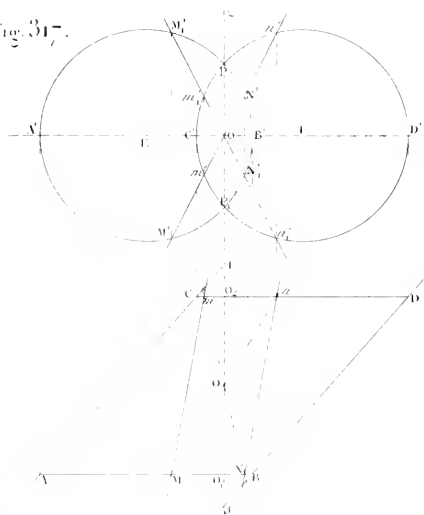

Fig. 318.

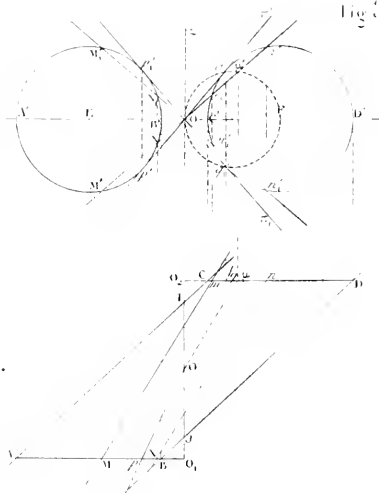

Fig. 319.

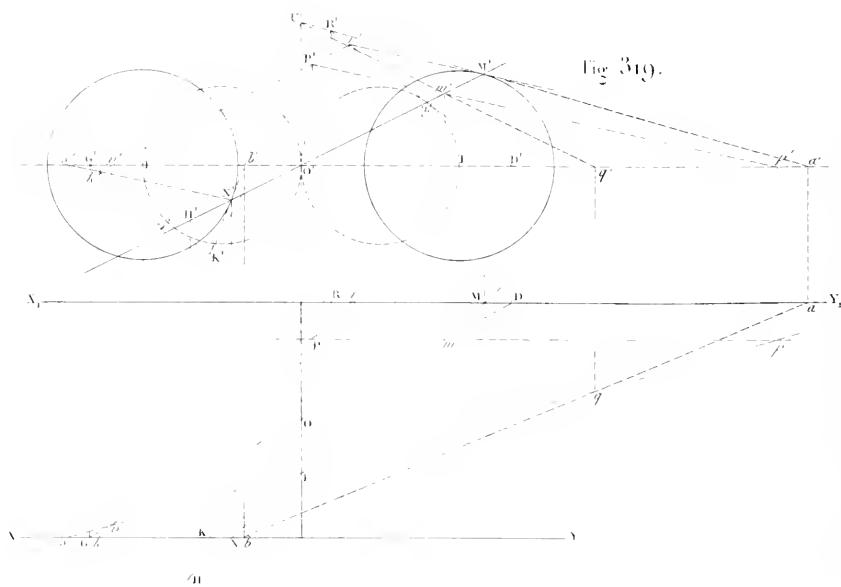

Fig. 320.

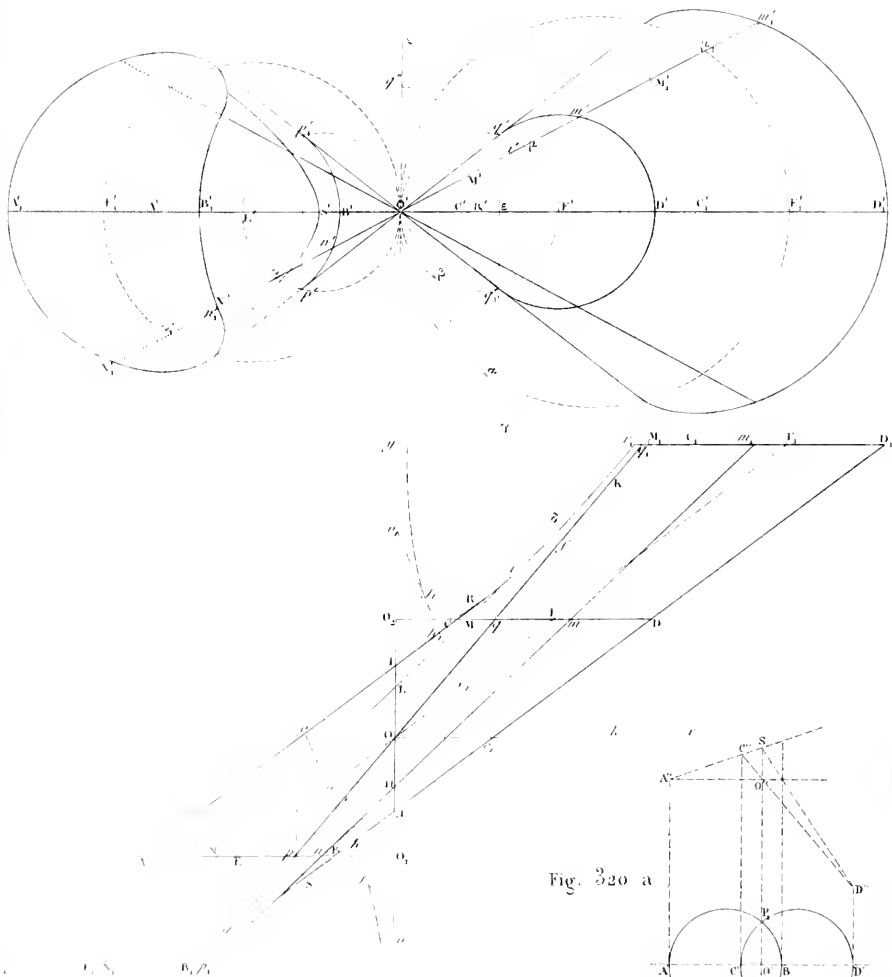

Fig. 320 a

Fig. 321.

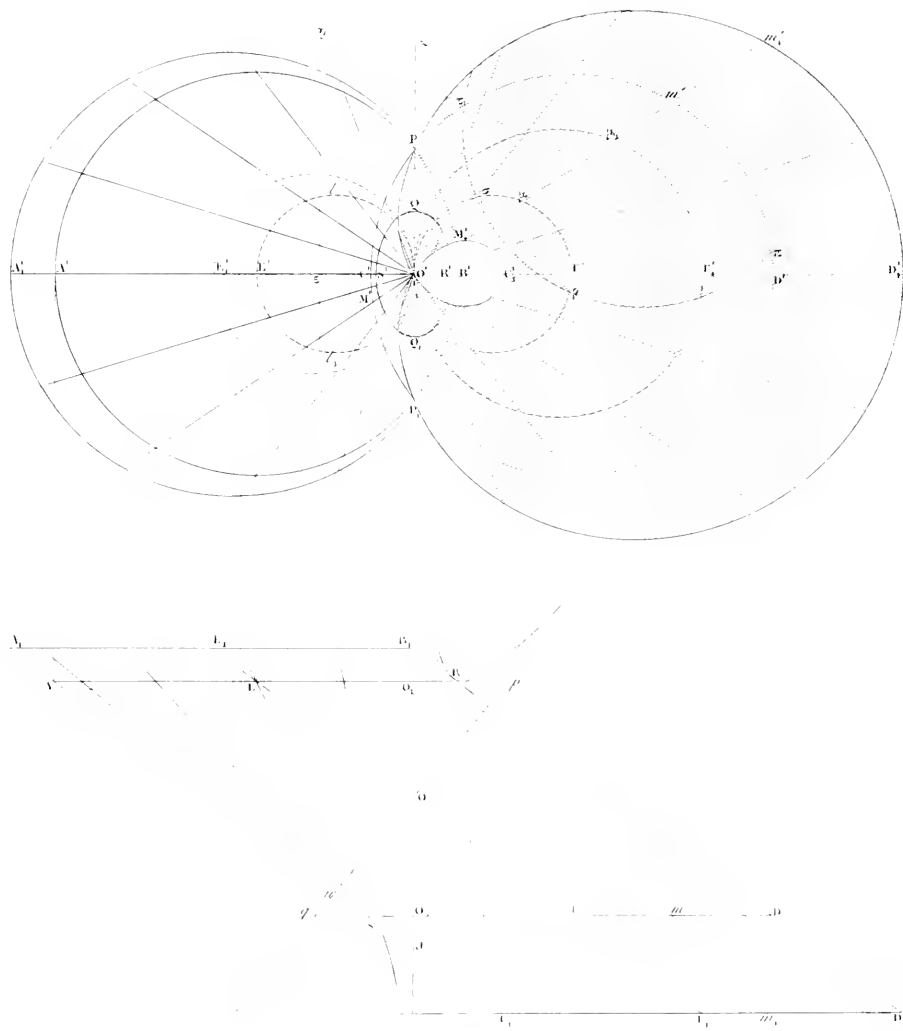

Fig. 322.

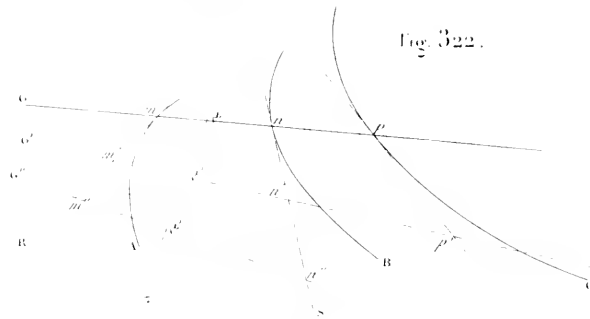

Fig. 323.

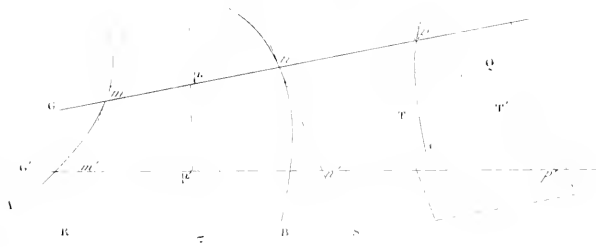

Fig. 324.

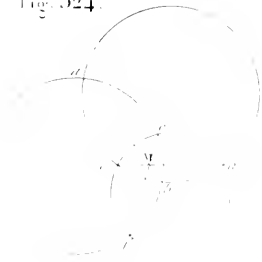
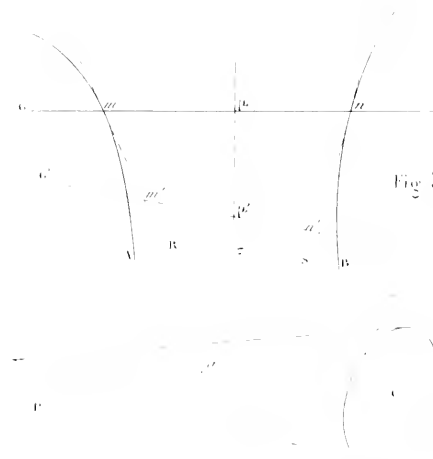

Fig. 325.





QA
501
L35
1880
Atlas
ptie.2

La Gournerie, Jules de
Traité de géométrie

PeasSci

PLEASE DO NOT REMOVE
CARDS OR SLIPS FROM THIS POCKET

UNIVERSITY OF TORONTO LIBRARY

