





Drawn by T. Webster from a sketch by M. Mawe.

T. Woolnoth Sculp.

*View of Negroes washing for Diamonds at Mandango
on the River Sigitonhonha in Cerro do Frio. Brazil.*

MINERALS

TRAVELS

IN THE

INTERIOR OF BRAZIL,

PARTICULARLY IN THE

GOLD AND DIAMOND DISTRICTS
OF THAT COUNTRY,

BY AUTHORITY OF THE PRINCE REGENT OF PORTUGAL;

INCLUDING

A VOYAGE TO THE RIO DE LA PLATA,
AND AN HISTORICAL SKETCH OF THE REVOLUTION OF BUENOS AYRES.

ILLUSTRATED WITH ENGRAVINGS.

By JOHN MAWE,

AUTHOR OF "THE MINERALOGY OF DERBYSHIRE."

LONDON:

PRINTED FOR LONGMAN, HURST, REES, ORME, AND BROWN,
PATERNOSTER-ROW.

1812.



164009

SMITHSONIAN
NOV 2 - 1953
LIBRARY

Strahan and Preston,
Printers-Street, London.

TO
HIS ROYAL HIGHNESS
THE PRINCE REGENT OF PORTUGAL,
PRINCE OF BRAZIL, &c. &c. &c.

SIR,

UNDER the sanction of Your Royal Highness, I performed the Travels in your dominions of Brazil, of which the following is a Narrative: in obedience to the command with which Your Royal Highness honoured me on my departure from Rio de Janeiro, I now submit it to the Public.

Unbiassed either by partiality or prejudice, I have endeavoured to give a clear and faithful relation of what I have seen. In describing the present state of Mining and Agriculture in your dominions, I have taken the liberty to suggest some improvements, which, in my humble opinion, would tend to increase the revenue of Your Royal Highness, and multiply the resources of the country. These are the princi-

pal grounds on which I rest my hope, that the work, notwithstanding its imperfections, will be found not unworthy of being patronized by a Prince, whose happiness consists in promoting that of his subjects.

On this occasion I cannot but express the deep regret I feel at the decease of that excellent member of Your Royal Highness's cabinet, the Condé de LINHARES, whose goodness and greatness of mind encouraged every pursuit tending to the public advantage, with a zeal which true patriotism alone could inspire. Had he lived, I might have presumed on his receiving these pages with that kind and friendly partiality which ever distinguished his conduct towards me. Bereft of that Nobleman's protection, I stand unsupported before Your Royal Highness, to whose patronage I submit this work, as a testimonial of the high respect with which I have the honour to be

Your Royal Highness's most obliged

and most humble servant,

JOHN MAWE.

CONTENTS.

CHAP. I.

VOYAGE to Cadiz, and thence to the Rio de la Plata. — Misfortunes at Monte Video. — Character of the Inhabitants. — Trade. — Geological Remarks . . . Page 1

CHAP. II.

Journey to Barriga Negra. — Geology of the Country. — Limestone, and Mode of burning it. — Horned Cattle. — Peons. — Horses. — Defective State of Agriculture. — Manners of the Inhabitants. — Dress. — Wild Animals. — Monte-Video taken by the British. — My Return thither 18

CHAP. III.

Expedition against Buenos Ayres. — Causes of its Failure. — Account of the Population of the Country, and of the various Classes which compose it 35

CHAP. IV.

Voyage to St. Catherine's. — Description of that Island, and of the Coast in its Vicinity. — Arrival at Santos, and Journey thence to St. Paul's 45

CHAP. V.

Description of St. Paul's. — System of Farming prevalent in its Neighbourhood. — Excursion to the Gold-Mines of Jaragua. — Mode of working them. — Return to Santos 67

CHAP. VI.

Coasting Voyage from Santos to Zapitiva, and Journey thence to Rio de Janeiro . . . 88

CHAP. VII.

Description of Rio de Janeiro. — Trade. — State of Society. — Visit to the Prince Regent's Farm at Santa Cruz 97

CHAP. VIII.

Journey to Canta Gallo Page 111

CHAP. IX.

Description of Canta Gallo.— Of the Gold-washing of Santa Rita.— Account of the supposed Silver-Mine 120

CHAP. X.

Permission obtained to visit the Diamond Mines.— Account of a pretended Diamond presented to the Prince Regent.— Journey to Villa Rica 137

CHAP. XI.

Origin and present State of Villa Rica.— Account of the Mint.— Visit to the City of Mariana.— Excursion to the Fazendas of Barro and Castro, belonging to His Excellency the Condé de Linhares 171

CHAP. XII.

Journey from Villa Rica to Tejuco, the Capital of the Diamond District. 202

CHAP. XIII.

Visit to the Diamond Works on the River Jigitonhonha.— General Description of the Works.— Mode of Washing.— Return to Tejuco.— Visit to the Treasury.— Excursion to Rio Pardo.— Miscellaneous Remarks 219

CHAP. XIV.

Some Account of the Districts of Minas Novas and Paracatù.— Of the large Diamond found in the River Abaitè 238

CHAP. XV.

Observations on Tejuco and Cerro do Frio 247

CHAP. XVI.

General View of Minas Geraes 267

CHAP. XVII.

Brief Notices on the Capitaniae of Bahia, Pernambuco, Seara, Maranham, Para, and Goyaz 280

CHAP. XVIII.

Geographical Description of the Capitania of Matto Grosso . . . Page 292

CHAP. XIX.

Account of the Capitania of Rio Grande . . . 316

CHAP. XX.

General Observations on the Trade from England to Brazil . . . 322

APPENDIX . . . 337



TRAVELS, &c.

CHAP. I.

Voyage to Cadiz and thence to the Rio de la Plata.—Misfortunes at Monte Video.—Character of the Inhabitants.—Trade.—Geological Remarks.

A TRAVELLER who ventures to present his Narrative to the Public, is generally encouraged by the conviction that it contains novel and interesting information. This is my case; and I beg leave, before I begin my story, briefly to state the subject of it to the Reader, in order that he may perceive the grounds on which it claims his attention.

In the year 1804, I was induced to undertake a voyage of commercial experiment, on a limited scale, to the Rio de la Plata. On my arrival at Monte Video, the ship and cargo were seized; I was thrown into prison, and afterwards sent into the interior, where I was detained until the taking of that place by the British troops under Sir Samuel Auchmuty. I afterwards obtained leave to accompany the army under General Whitelocke, which was sent against Buenos Ayres, and I rendered such services to the expedition as my two years' residence in the country enabled me to perform. At the termination of that expedition, I went to Rio de Janeiro. A letter of introduction to the Viceroy of Brazil,

which was given me by the Portugueze ambassador at London, gained me the notice and protection of his brother, the Condé de Linhares, who had then just arrived with the rest of the Court, and who recommended me to the Prince Regent, as a person devoted to mineralogical pursuits, and desirous of exploring the ample field for investigation which his rich and extensive territories presented. His Royal Highness was graciously pleased to further my views, not only by granting me letters to the public functionaries of the various places I wished to visit, but by ordering an escort of soldiers, and every other necessary provision for performing the journey. I had the more reason to be grateful for this munificent patronage, because I knew that a decree existed prohibiting all foreigners from travelling in the interior of Brazil, and that no other Englishman had ever begun such an undertaking with those indispensable requisites to its success, the permission and sanction of the Government.

Observations, made, in the course of these Travels, on the country and on its inhabitants, constitute the main part of the volume now offered to the public. Whatever be their faults or their merits, they relate to a subject at present extremely interesting, both in a political and a commercial point of view; they profess to develop the physical resources of a colony which, through recent changes, is likely to become an empire; and in part, to portray the character of a nation which is now the most ancient, and has ever been the most faithful, ally of Great Britain.

In the year before-mentioned, pursuant to my design of visiting the Rio de la Plata, I obtained His Majesty's licence to go thither in a vessel (my own property by a bottomry-bond) under Spanish colours, a precaution rendered necessary by our being at war with France, and by the hourly expectation of a rupture with Spain. My licence was, strictly speaking, a special one, "protecting all I had on board the Spanish vessel, if, in case of a rupture with Spain, she should be taken by any of our ships of war, priva-

“teers,” &c. I sailed on the first of August 1804, and after a fair voyage arrived at Cadiz. It there became necessary to conform to the colonial regulations of the government, which require that all articles of merchandize sent to South America be landed and entered at the Custom-House, where, on payment of a fee, they receive the necessary marks to make them pass for produce or manufactures of the mother-country. During my stay in this port occurred that unfortunate capture of the homeward-bound frigates by the British squadron off Cape Finisterre; which, as may naturally be supposed, rendered the situation of an Englishman in Cadiz extremely embarrassing. War soon broke out between the two countries, and this port was rigorously blockaded. In addition to the ills which befel me in consequence, I was near falling a victim to the plague which was then raging, and which swept away almost a fourth part of the inhabitants of Cadiz, of Gibraltar, and of other places in that region. The effects of this awful scourge were visible in every social circle; almost in every family; and perhaps the despondency caused by witnessing them, contributed to extend its fatal sway. I still shudder to remember, that of a party of strangers, amounting to five (myself included), who took coffee together one Saturday evening in perfect health, I, on the Monday-week following, was the sole survivor. The progress of the disorder was so rapid, that three of them died on the fourth day. It would be tedious to detail the particulars of my own case; but a short account of it will not perhaps be without its use to those who may, at any future time, be exposed to similar danger.

The first symptoms I felt were extreme lassitude, heaviness, and tremor, accompanied with a considerable degree of fever, which I first observed while on my way to dine with a friend. I returned to my lodgings and took a grain of calomel, as had been my daily custom for some time. This precaution had been suggested to me by a skilful chemist in London, who furnished me with a quantity of that medicine, to be regularly taken whenever

I was exposed to contagion of any kind. Believing, however, that my complaint was only a bad cold, I took some tea and retired to bed, but passed a restless night. In the morning while at breakfast, among the Spanish family with whom I lodged, my appearance, and aversion to food, excited the apprehensions of the lady of the house, a humane and (to use an expressive family-phrase) a *motherly* woman, who assured me that I had the plague. Unwilling to believe her, though continually growing worse, I increased my dose of calomel and took tea very copiously. In the afternoon of the day following I wrote to the worthy Mr. Duff, the consul-general, requesting him to send Dr. Fife, an English physician, who, on visiting me, confirmed what my hostess had said, adding however that the symptoms were favourable. He prescribed no medicines, but ordered me to take tamarinds and hot mint tea at intervals in large quantities. After a third restless night, I found my pulse was above 130, and the fourth day brought the crisis of my disorder. At night I was suddenly seized with extreme sickness, which lasted the longer, by reason of the great quantities of liquid I had taken; a profuse perspiration ensued, and did not abate until I was reduced from a robust habit of body to a state of extreme meagreness and debility. I now recovered rapidly, and in six days was enabled to visit my friends. Dr. Fife assured me that the favourable turn of my illness was owing to the calomel I had previously taken, and added, that if I had doubled the dose on the first appearance of the symptoms, there would, probably, have been no occasion for his attendance.

War being now formally declared, the port of Cadiz was blockaded with greater rigour than ever, and I had many difficulties to encounter in preparing to continue my voyage. The ill conduct of my captain threw additional obstacles in my way, and gave me doubts respecting his character and experience, which in the sequel proved but too well-founded. At length the cargo, having passed the Custom-House conformably to the understood

conditions, was safely embarked, and in the latter end of March 1805 we sailed. Our crew consisted wholly of Genoese and Catalans, with the exception of the pilot, a Biscayan, and one good Portuguese sailor. As might naturally be expected, we were detained by one of the blockading squadron, the *Amphion*, an officer belonging to which, accompanied me to the Admiral, Sir John Orde, who, after examining my papers, treated me with every civility, and gave me a certificate directing all ships of war, &c. of his squadron not to molest us, but to render us, if necessary, all the assistance in their power. This protection was of service to us some days afterwards, when we were boarded by the *Mercury* frigate, but, on exhibition of our documents, immediately permitted to proceed. On another occasion, however, it availed us but little; we were detained by a cutter privateer from Guernsey, manned by a set of ruffians, whose captain, after occupying me for two hours with his insults and menaces, at length suffered me to pursue my voyage. It is scarcely necessary to advert to another detention within four leagues of Santa Cruz in Teneriffe, by the Tartar lugger, also from Guernsey, unless for the sake of contrasting the handsome treatment I experienced from its commander, with the brutal conduct of the other Guernsey-man.

We touched at Santa Cruz solely for the purpose of taking in water, having sailed from Cadiz with a strong Levant or easterly wind, which, as it was a rare advantage, did not allow us time to lay in a stock for the voyage. During our short stay here, I was permitted, after undergoing an examination, to collect some geological specimens; they were all of the volcanic species, intermixed with olivin and augite.

Continuing our course to the southwards, we had for some days a strong trade wind, but were afterwards exposed to a succession of those calms which frequently prevail between the 7th and 2d degrees of latitude north of the line. The tediousness of these delays was in some degree diverted by immense shoals of bonitos,

albicores, and flying-fish ; numbers of the latter frequently darted against our sails and fell on board ; they afforded excellent eating. The quantity of bonitos we caught filled all our empty barrels, and as our ballast was salt, we easily preserved them. Their flesh being coarse and dry, cannot be relished without good sauce, and for this reason we threw away all except the choice parts. Our attention was constantly engaged by the numbers of these lively fish swimming and darting in all directions, and by the efforts of the poor defenceless flying-fish to avoid them. The latter, leaping out of the water for safety, frequently fell into their pursuers' mouths, which were ever erect and open to receive their prey. At night the vivid phosphorescent appearance of these countless shoals, ever in quick motion, bore a near resemblance to that of a fire-brand whirled violently about. They attended our course for twelve or fourteen days, and at length forsook us, much to our regret, as they had so long constituted our sole amusement.

Wearied and exhausted by frequent calms under a vertical sun, we were at length relieved by a breeze ; and crossing the line at longitude 23° W. had a favourable passage to the mouth of the great river Plata, our entrance into which we were enabled to judge from the muddy colour of the water and from numerous flights of sea-birds, long before we saw land.

Our passage was impeded by a strong south-west gale, in these parts called a Pampero, which blew for several days, and obliged us to lay the vessel to during the whole time ; we shipped so much water that our boats were hourly in danger of being washed away, and, owing to the stupid carelessness of a Genoese sailor, our cabin was at one time half-filled. The gale at length ceased ; a breeze sprung up to the eastward, and we made all possible sail : after running a south-west course for two days, we found soundings at thirty-five fathoms water, and on the second day following at noon, saw the high land of Maldonado at a distance of about nine leagues, and the Isle of Lobos four or five leagues ahead. Passing through the chan-

nel which divides them, we encountered a strong breeze, and soon afterwards found ourselves in a very critical situation ; a dark night, a heavy and increasing gale of wind, the violent uncertain currents of the river, the English bank to the south, and the Isle of Flores to the west-north-west. The captain knew nothing of the navigation, and I was obliged to command instead of advising. I caused the vessel to be laid to, under the smallest and most manageable sail possible ; kept the lead continually going and wore the vessel every two hours. The night was one of the most dreadful I ever witnessed ; the moon was over-cast by heavy black clouds pouring torrents of rain, accompanied with terrible lightning and loud thunder ; the waves, owing to the shallowness of the water (seven and eight fathoms), appeared like breakers. At daylight our prospect was not much bettered ; a dense fog hindered us from seeing at all beyond the vessel, and the conflict of the wind with the current rendered the waves still more boisterous. In the course of the morning the thunder moderated, but the stormy rain continued ; no object was distinctly visible ; hidden rocks and sand-banks lay on each side of us ; and we were approaching a channel not a mile wide, rendered more formidable by a strong and ever-shifting current. In consequence of incessant exertion I was in a most exhausted state, but the captain and crew were incapable of affording me a moment's respite ; danger seemed to have deprived them of their reason, and they looked on all that passed with a fearful and senseless apathy. I had often had occasion to observe the intrepid constancy and activity of British seamen in similar emergencies, and I could not but be struck with the contrast. We shipped several heavy seas which had the appearance of broken-water, and hence it again became necessary to keep the lead continually going. At eleven A. M., on finding that we shoaled our water extremely fast, being already in four fathom and over very hard ground, I was convinced that we were at the head of the English bank, and therefore immediately wore on

the other tack toward the island of Flores. The fog prevented us from taking a meridional observation, but at three P. M. it cleared, and to our great joy we saw Monte Video before us at four leagues distance. Our seamen now took heart, and began to be more expert; we made all sail, but, the wind gradually declining, and a strong current setting directly from the harbour, we were obliged in the evening to let go our anchor about two leagues outside the port. Night set in, accompanied by heavy gusts of wind, which required me to be constantly upon deck, as Spanish seamen know nothing that belongs to an anchor-watch, and heartily grudge the care and labour that it demands. Hence they did not fail to bestow ill-natured sneers and gibes on me and my nation for the trouble I caused them, in calling them up to let go another anchor, little reflecting that had it not been ready ere they left the deck, we should in all probability have been wrecked. Another twenty-four hours of unfavourable weather ensued, and on the day following we entered the harbour of Monte Video.

The hardships I experienced in reaching this ill-fated port, were a fit prelude to the misfortunes that awaited me there. We were bound for Buenos Ayres, but my captain, who in London and at Cadiz had assured me that he had the experience of a pilot in the Rio de la Plata, proved totally ignorant of its navigation, and urged this circumstance as his reason for putting into Monte Video. Happy should I have been, if this had been the only instance of his ignorance; he gave an ill-judged and blundering report of me to the governor, and the sailors affirmed that I was an Englishman, declaring at the same time that we had passed an English squadron under Spanish colours. This statement was enough to whet the avarice of the governor, who, notwithstanding I had served the colony, in bringing a cargo which was then much wanted, and every article of which had paid legal duty in Cadiz, ordered me to be thrown into prison. I was placed in close confinement on board a wretched sloop of war; and though my health was much

impaired in consequence of exertion during the voyage, I was denied every comfort, except such indulgences as the officers, who lived on shore, could at times clandestinely allow. Unprovided with letters of recommendation to any person in the town, and destitute of the means of making myself known, I had the mortification to see the property I had brought with me seized, and my papers taken away to be searched and examined. I was enjoined to make declarations, and to give evidence against myself, to men whose sole wish was to find a pretext for criminating me. After three or four examinations, it was found that I had sailed from Cadiz with a cargo of goods, marked, manifested, and duly registered, as Spanish ; nor could any circumstance be discovered as a ground of accusation against me, but the strong suspicion that I was an Englishman, and on that account could not be too harshly treated. I had no lenity to expect from the governor, nor indeed from any of his advisers, who were, for the most part, men of the lowest order, refugees from Old Spain in consequence of criminal prosecutions. The rest of his associates were the captains and officers of two Spanish privateers, all Frenchmen, whose natural prejudices, no doubt, contributed to foment his antipathy against me. My sole reliance was on the consignee of the cargo, who at length arrived from Buenos Ayres ; but instead of clearing up the affair, he joined my persecutors, knowing that if he gave security he should have the cargo delivered to him. This favourable opportunity he failed not to embrace ; he sold the property, and withheld the proceeds under the pretext, that he could not pay them over to me while I remained a prisoner. This conduct to one who had depended on him for support, and who relied on his continually delusive promises of assistance, proves him to be one of those mean and spiritless beings whose station in society is mid-way between the simpleton and the knave.

My confinement would probably have been long, but for the good services of a Lîmenian who attended me during my illness in Cadiz, and who came over in the vessel with me. He was the only person I

was permitted to see ; and he interested himself so much in my behalf, that an old gentlewoman with whom he had formed an acquaintance, determined, on hearing my story, to procure my liberation, and never rested until she had procured two bondsmen to answer for my appearance when called for.

The treatment I experienced, while in prison, is one of the many instances of oppression which disgraced the administration of the governor, Pasqual Ruis Huidobro. It is well known that his political conduct was entirely subservient to the interests of the French, and that he lost no opportunity of evincing his attachment to their cause. As a further proof of this, I may state, that he caused all the captured English seamen to be confined in the prison, and, although its spacious court was doubly grated and guarded, he debarred them the use of it, and ordered them to be shut up night and day in a small room, the door of which was never opened except when victuals were given them.

Aware of his severity, and knowing that I was the only prisoner at large, I was very circumspect, and strove to guard my conduct and discourse against artful misconstruction ; but I had the misfortune to incur his displeasure at a moment when I least suspected it, by a very trivial, and certainly unintentional offence. Some written papers had been stuck up in various parts of the town, by order of Government, inviting foreign seamen to enter the service. Returning home at midnight from a visit, I observed one of these placards ; the rain, which was pouring very fast, had partly detached it from the wall, and it was blown to and fro by the wind. Curious to examine the contents of a paper that had attracted the attention of many persons in the course of the day, I took it down and carried it home with me ; this was observed by an old Spaniard of the name of Dias, who gloried much in having it in his power to injure me, though a perfect stranger to him, and unconscious of having done any thing to excite his malice. At the instance of this man an order was issued by the governor for my arrest ; I was roused from my bed by the

officers, and again hurried to prison. What charges were brought against me I could learn only by report; they were vague and indefinite, and no opportunity of answering them was allowed me. After a close confinement of six weeks, during which period my case was laid before the Viceroy of Buenos Ayres, I was again suffered to be at large on payment of a fee of three hundred dollars. It was to the humane exertions of my advocate, seconded by those of the Lime-nian and the lady before-mentioned, that I owed this mitigation of my captivity, and I gratefully acknowledge that they made every provision in their power to render my situation comfortable.

During my stay at Monte Video another adventure befel me, which had well nigh cost me my life; I am induced to relate it, by reason of the insight it gives into the character of a certain class of the people. I had gone on a shooting excursion to the promontory opposite Monte Video, with my much-valued friend Captain Collet, owner of two or three large American ships, and M. Godefroy, a merchant, resident in the town. After some hours sport we met a party of four Spaniards, among whom were Mr. Ortega, the consignee of Captain Collet, and a person called Manuel d'Iago. Our friend M. Godefroy had some conversation with them at a short distance from us, and on his return gave us to understand that D'Iago had said it would not cost him above five hundred dollars to send a pair of bullets through me, and that had I been alone he would not have scrupled to do it. For this blood-thirsty insinuation I was at a loss to conjecture any motive, nor knew I the man, except by report, which designated him as a captain of militia, extremely rigorous in his treatment of the unfortunate English, whenever his turn to mount guard at the prison subjected them to his authority.

We pursued our diversion; he and his party meanwhile arrived at the Signal-house, about three miles above us, where they took refreshment. Some space of time afterward we observed a horse-soldier ride down towards us, who on approaching eyed us with a

look of great suspicion. I had some little talk with him, having frequently seen him there before. He returned directly to the Guard-house, and an hour afterwards five blandengues, or horse-soldiers, sallied from the place at full speed, and, surrounding us, demanded our arms at the peril of our lives. Each of us obeyed, by surrendering his fowling-piece, M. Godefroy at the same time enquiring the cause of this extraordinary treatment; but they ordered him to be silent, and to march on along with us, or they would tie him on horse-back. We were conducted to the Guard-house, and delivered (the officer being absent) to the corporal on guard, a fiery old Spaniard, who ordered us into an inner room and placed two sentinels at the door. The fellow was so stifled by passion, that we could not get an answer from him; at every moment he was drawing a long sabre which hung at his side, and venting his fury in the most abusive language. After a full half-hour of expostulation on our part, and menace on his, M. Godefroy obtained a hearing from him, and, declaring that he was a merchant, married and actually settled in Monte Video, begged to know by what authority and under what pretext he was imprisoned. The corporal, on learning this, sent a soldier to the officer on guard, and while waiting his return, related that D'Iago had described us as Englishmen belonging to a privateer, who had landed with an intention to blow up the powder-magazines, kill bullocks, and plunder the natives. It was evident from his manner that he was very willing to believe this account, and that by treating us with severity he hoped to display his zeal for the service, and obtain promotion. M. Godefroy's testimony being at length attended to, another soldier was dispatched to D'Iago's party, who were not yet embarked, with notice that one of us affirmed himself to be a resident in Monte Video. This they did not contradict, but persisted in their accusations of the rest of our party; Mr. Ortiga denied any knowledge of Captain Collet, probably imagining that, in case of our conviction, he should benefit by the cargoes which the latter had consigned to him; and for

me, whom they denounced as a spy, no punishment in their opinion could be too ignominious. On the return of the soldier, the corporal thought proper to release M. Godefroy, who took our boat to cross the port to Monte Video with the intention of procuring an order for our liberation; but they had scarcely sailed when a gust of wind arose, and as he and the two boys he had with him could not manage the sails, they were nearly overset, and after considerable danger were picked up by a ship in the road. Meanwhile Captain Collet and I remained in strict custody, and at every syllable of complaint we uttered, the corporal brandished his sabre over our heads, roared out for the guard, and vociferated the most opprobrious language against the English. Thus threatened at every moment with assassination, we withdrew into a corner of the room, and quietly waited until the officer on guard arrived, when we were conducted in great form, between two men with drawn swords, into the room where he sat to receive us. Nothing could exceed my joyful surprise at recognizing in the officer an excellent and worthy friend, whom I had often visited at his chacara or farm, and who had given me repeated proofs of his liberal disposition and intelligent mind. His surprize exceeded mine; for instead of plunderers or spies, such as report had described us, he found an American merchant and a prisoner at large under bail. He was deeply grieved and ashamed at the treatment we had met with, liberated us immediately, mounted us on his own horses, and appointed a trusty person to attend us to Monte Video, where we arrived at eight in the evening. The disappointment of the corporal appeared as deep as his rage had been violent; and the recollection of his conduct operated on us as a warning against persons of his class, who rarely see an opportunity of doing mischief to a stranger without a strong inclination to avail themselves of it.

During the time I was at large, I had leisure to acquire some knowledge of Monte Video. It is a tolerably well-built town, standing on a gentle elevation at the extremity of a small peninsula,

and is walled entirely round. Its population amounts to between 15,000 and 20,000 souls. The harbour, although shoal, and quite open to the pamperos, is the best in the Rio de la Plata; it has a very soft bottom of deep mud. When the wind continues for some time at north-east, ships drawing twelve feet water are frequently a-ground for several days, so that the harbour cannot be called a good one for vessels above three hundred or four hundred tons.

There are but few capital buildings; the town in general consists of houses of one story, paved with brick, and provided with very poor conveniences. In the square is a cathedral, very handsome, but awkwardly situated; opposite to it, is an edifice divided into a town-house or cabildo, and a prison. The streets, having no pavement, are always either clouded with dust or loaded with mud, as the weather happens to be dry or wet. In seasons of drought the want of conduits for water is a serious inconvenience, the well, which principally supplies the town, being two miles distant.

Provisions here are cheap and in great abundance. Beef in particular is very plentiful, and, though rarely fat or fine, makes excellent soup. The best parts of the meat may, indeed, be called tolerable, but they are by no means tender. The pork is not eatable. Such is the profusion of flesh-meat, that the vicinity for two miles round, and even the purlieus of the town itself, present filthy spectacles of bones and raw flesh at every step, which feed immense flocks of sea-gulls, and in summer breed myriads of flies, to the great annoyance of the inhabitants, who are obliged at table to have a servant or two continually employed in fanning the dishes with feathers, to drive away those troublesome intruders.

Of the character of the inhabitants of Monte Video, I am perhaps not qualified to speak impartially, having been treated with unmerited harshness, deprived of my property, and repeatedly persecuted on the most groundless suspicion. These abuses, however, are solely chargeable on the governor and on the persons immediately under his influence; and I am bound in fairness to avow that

I did not perceive any disposition in the generality of the people to injure or oppress me. From individuals in the town I received all the assistance which disinterested benevolence could afford to a person in my critical situation; and were I, from the impulse of gratitude, to judge of the whole by a part, I should say, that the inhabitants of Monte Video, particularly the Creolians, are humane and well disposed, when not actuated by political or religious prejudices. Their habits of life are much the same with those of their brethren in Old Spain, and seem to proceed from the same remarkable union of two opposite but not incompatible qualities, indolence and temperance. The ladies are generally affable and polite, extremely fond of dress, and very neat and cleanly in their persons. They adopt the English costume at home, but go abroad usually in black, and always covered with a large veil or mantle. At mass they invariably appear in black silk, bordered with deep fringes. They delight in conversation, for which their vivacity eminently qualifies them, and they are very courteous to strangers.

The chief trade of Monte Video consists in hides, tallow, and dried beef; the two former of these articles are exported to Europe, and the latter is sent to the West Indies, especially to the Havannah. Coarse copper from Chili in square cakes is sometimes shipped here, as well as a herb called *Matté* from Paraguay, the infusion of which is as common a beverage in these parts as tea is in England.

The inhabitants were by no means opulent before the English took the garrison, but through the misfortunes of the latter at Buenos Ayres, and the losses of our commercial adventurers by ill-judged and imprudent speculations, they were considerably enriched. The great prospects indulged in England, before the expedition to the Plata, of immense profits by trade to that river, have generally ended in ruin; very few, indeed, of the speculators have escaped without considerable loss. Property, once litigated, might be considered in a fair way for confiscation; and in case of its having been deposited until certain questions were decided,

restitution was generally obtained at the loss of one half. It frequently happened that goods detained in the Custom-houses or lodged in private stores in the river were opened, and large quantities stolen. The party on whom suspicion seemed most reasonably to fall was the consignee, who, even with a few cargoes, was generally observed to get rich very rapidly. Not contented with the profits accruing from his commission, he seldom scrupled to take every advantage which possession of the property afforded him, of furthering his own interests at the expence of his correspondent. The dread of a legal process could be but a slight check upon him, for in the Spanish courts of justice, as well as in others, a native and a stranger are seldom upon equal terms. Other circumstances have concurred to enrich the inhabitants of Monte Video. It is a fact which I afterwards ascertained, that the English exported thither, goods to the amount of a million and a half sterling, a small portion of which, on the restoration of the place to the Spaniards, was re-shipped for the Cape of Good Hope and the West Indies; the remainder was for the most part sacrificed at whatever price the Spaniards chose to give. As their own produce advanced in proportion as ours lowered in price, those among them who speculated gained considerably. The holders of English goods sold their stock at upwards of fifty per cent. profit immediately after the evacuation of the place.

The climate of Monte Video is humid. The weather, in the winter months (June, July, and August), is at times boisterous, and the air in that season is generally keen and piercing. In summer the serenity of the atmosphere is frequently interrupted by tremendous thunder-storms, preceded by dreadful lightning, which frequently damages the shipping, and followed by heavy rain which sometimes destroys the harvest. The heat is troublesome, and is rendered more so to strangers by the swarms of mosquitoes, which it engenders in such numbers that they infest every apartment.

The town stands on a basis of granite, the feldspar of which is for the most part of an opaque milk-white colour, in a decom-

posing state ; in some places it is found of a flesh-red colour and crystallized. The mica is generally large and foliated, in many places imperfectly crystallized. It is obvious that the excessive quantity of mud in the harbour and throughout the banks of the river cannot have been formed from this stratum. The high mount on the opposite side of the bay, which is crowned with a Light-house, and gives name to the town, is principally composed of clay-slate in laminæ perpendicular to the horizon. This substance appears much like basalt in texture, but its fracture is less conchoidal ; it decomposes into an imperfect species of wakké, and ultimately into ferruginous argil. Beds of clay, from which flows much water, are observable in various parts of the mountain.

The vicinity of Monte Video is agreeably diversified with low gently-sloping hills, and long valleys watered by beautiful rivulets ; but the prospects they afford are rarely enlivened by traces of cultivation ; few enclosures are seen except the gardens of the principal merchants. The same defect appears in a north-east direction from the town, where similar varieties of hill, valley, and water prevail, and seem to want only the embellishment of sylvan scenery to complete the landscape. Some wood, indeed, grows on the margin of the Riachuelo, which is used for the building of hovels and for fuel. There is a pleasant stream about ten leagues from Monte Video called the Louza, the banks of which seem to invite the labour of the planter, and would certainly produce abundance of timber*. It is to be remarked that the almost entire want of this article here, occasions great inconvenience and expence : wood for mechanical purposes is extremely scarce, and planks are so dear that hardly one house with a boarded floor is to be found.

* Here I found mint, caraway, and many other aromatic herbs, growing wild in the greatest luxuriance. The stratum of vegetable earth was at least two yards thick.

CHAP. II.

Journey to Barriga Negra.—Geology of the Country.—Limestone, and Mode of burning it.—Horned Cattle.—Peons —Horses.—Defective State of Agriculture.—Manners of the Inhabitants.—Dress.—Wild Animals.—Monte Video taken by the British.—My Return thither.

ON the arrival of General Beresford's expedition in the river, I was again ordered into close confinement, but my advocate obtained permission for me to be sent into the interior, under a stipulation not to approach within forty leagues of Monte Video. This removal seemed for the moment to shut out all hope of obtaining my liberty, and at the same time threatened to expose me to fresh dangers, but I derived some consolation from the generous offers of shelter and protection made to me by a worthy Spaniard named Don Juan Martinez, whose establishment, not more than fifty leagues from the lake of Meni, was situated at the full distance prescribed in the orders respecting me. A retreat so remote and unfrequented offered few amusements to relieve the tediousness of banishment, but it at least afforded the prospect of a wider range for mineralogical observation, and of ampler leisure to attend to this my favourite pursuit.

In the course of the journey thither, my attention was principally engaged by the wild and solitary aspect of the country. About twenty-five leagues north-east from Monte Video, I observed an irregular ridge of granite mountains in a direction nearly north and south, and the country from this distance gradually assumes a rugged appearance. Mica is very common upon the road, and in some places quartz; on one hill I gathered several detached crystals of the latter substance. The ravines of these stony wilds and the wooded margins of the rivers afford shelter to many ferocious animals,

such as jaguars, here called tygers, lions, and ounces. Here are also great numbers of wild dogs which breed in the rocks, and at times make great havoc among the young cattle. The farms in this district, for the most part, include tracts of land from twenty to thirty miles in length by half that extent in breadth, watered by pleasing streams. Vast herds of cattle are bred upon them; it is calculated that each square league sustains 1500 or 2000 head.

At the distance of about forty leagues from Monte Video, in the direction above mentioned, the range of hills gradually lessens and disappears; the country opens finely on the left, and is intersected by numerous rivulets. After crossing several of these we arrived at the head of a little brook called Polancos, which a few miles below, assumes the name of Barriga Negra. It there receives several small streams, and in the course of ten leagues is augmented by the confluence of some others; becoming thus a considerable river, about as large as the Trent at Gainsborough, it is denominated Godoy, but on passing into the Portugueze territories it changes its name to that of Zebolyati and flows into the Lagun Meni. Near the junction of two rivulets, that form the Barriga Negra, stands the great lime-kiln of my friend, in whose house I took up my residence, and was received with that kindness and sincere hospitality which in an instant dispelled every doubt from my mind, and excited in me sentiments of gratitude that were every day more deeply impressed in my heart.

Having become thoroughly domesticated in my new abode, I began to take excursions into the surrounding district and the parts beyond it. The country in general may be termed stony and mountainous, though its inequalities do not exceed those of Derbyshire. No traces of either volcanic or alluvial matter are to be found; the solid rock frequently appears on the surface, and in many places projects in masses of various sizes. The mountains and rocks are of granite; no veins of metallic substance have hitherto been discovered, but fine red and yellow jasper, chalcedony, and quartz, are not unfre-

quently found loose on the surface. Some fossils of the asbestos kind and some very poor oxides of iron are likewise to be met with occasionally. The bases of many of the conical granite mountains are overlaid with (apparently) primitive lime-stone of an obscure blue colour, in laminae; I found in this substance many capillary veins of calx-spar, and sometimes crystals of pyrites. In one part of the vicinity there is a plain about half a mile square, on the surface of which are found large quantities of white lime-stone in nodules; it is of a very close texture, but being considered inferior in quality to the other species it is never converted into lime. The summits of these mountains are no where calcareous, excepting those of one ridge, the singular appearance of which induced me to trace it as far as was practicable. The lime-stone on these summits is of a close compact kind, united to transparent quartz in a tabular form, standing, as it were, in laminae perpendicular to the horizon, and thus presenting to the view a number of upright slabs somewhat similar to the grave-stones in a country church-yard. This singular ridge apparently commences at a mountain of very unusual form, and, extending about two miles, in which it crosses two or three valleys, terminates in a ravine of considerable depth. No vestige of calcareous crystallization appeared in this lime-stone*. It is singular to remark, that the cavities formed by the laminae afford refuge for reptiles, particularly rattle-snakes; the person employed by Mr. Martinez in getting the stone destroyed upwards of twenty-seven serpents of that species in the course of a few weeks.

The lime-stone is loosened by the wedge and lever, and brought away in large slabs to the kilns, where it is broken into fragments of a convenient size, and burnt with wood. The kilns are capacious, but so badly constructed that the process of calcination is very

* At a small town called Minas, ten leagues from Maldonado, I was informed that there was a lead mine in lime-stone. A piece of that substance was sent to me; it was flesh-coloured, granular, and close in texture.

slow and tedious. The lime, when slaked, is measured, put into sacks made of green hides, and sent in large carts, drawn by oxen, principally to Colonia, Monte Video, and Buenos Ayres.

Barriga Negra is distant about 160 miles north-east from Monte Video, about 120 from Maldonado, and 90 from the town of Minas. The country around it is mountainous, well watered, and not destitute of wood. The banks of the streams are thickly covered with trees, rarely, however, of large size, for the creeping plants, interweaving with the shoots, check their growth and form an impenetrable thicket. Here are numbers of great breeding estates, many of which are stocked with from 60,000 to 200,000 head of cattle. These are guarded principally by men from Paraguay called Peons, who live in hovels built for the purpose at convenient distances. Ten thousand head are allotted to four or five Peons, whose business it is to collect them every morning and evening, and once or twice a month to drive them into pens where they are kept for a night. The cattle by this mode of management are soon tamed; a ferocious or vicious beast I never saw among them. Breeding is alone attended to; neither butter nor cheese is made, and milk is scarcely known as an article of food. The constant diet of the people, morning, noon, and night, is beef, eaten almost always without bread, and frequently without salt. This habitual subsistence on strong food would probably engender diseases, were it not corrected by copious draughts of an infusion of their favourite herb *Matté*, which are frequently taken.

The dwellings of the Peons are in general very wretched, the walls being formed by a few upright posts interwoven with small branches of trees, plastered with mud inside and out, and the roof thatched with long grass and rushes. The door is also of wicker-work, or, in its stead, a green hide stretched on sticks and removeable at pleasure. The furniture of these poor hovels consists of a few scalps of horses, which are made to serve for seats; and of a

stretched hide to lie upon. The principal if not the sole cooking utensil is a rod or spit of iron stuck in the ground in an oblique position, so as to incline over the fire. The beef when spitted on this instrument is left to roast until the part next the fire is supposed to be done enough, then a twist is given to the rod, which is occasionally repeated, until the whole is cooked. The juices of the meat, by this mode of roasting, help to mend the fire, and indeed the people seem to think that they are fit for nothing else. The meat, which is naturally poor and coarse, being thus dried to a cake, bears little affinity to the boasted roast beef of England. Fuel, in some parts, is so extremely scarce that the following strange expedient is resorted to for a supply. As the mares in this country are kept solely for breeding, and are never trained to labour, they generally exceed the due proportion; a flock of them is frequently killed, and their carcasses, with the exception of the hides and tails, are used as firing.

The Peons are chiefly emigrants from Paraguay, and it is a singular fact that, among the numbers that are here settled, very few women are to be found. A person may travel in these parts for days together without seeing or hearing of a single female in the course of his journey. To this circumstance may be attributed the total absence of domestic comfort in the dwellings of these wretched men, and the gloomy apathy observable in their dispositions and habits. It is true that the mistress of an estate may occasionally visit it for a few months, but she is obliged during her stay to live in great seclusion, on account of the dreadful consequences to be apprehended from being so exposed.

The dexterous mode in which the Peons catch their cattle, by throwing a noose over them has been frequently detailed, but certainly no description can do full justice to their agility. They throw with equal precision and effect, whether at full gallop or at rest. Their method of catching horses by means of balls attached to

leather thongs, is similar to the former but more unerring; scarcely an instance has been known of its failure, except in those frequent trials which are requisite to acquire perfect skill in the practice.

They have a very singular and simple way of training mules and horses to draw light carts, coaches, &c. No harness is made use of; a saddle or pad is girted on, and a leather thong is fastened to the girth on one side, so that the animal moving forward, with his body in a rather oblique direction, keeps his legs clear of the apparatus which is attached to him, and draws with a freedom and an agility that in a stranger excite great surprise. A similar contrivance is used in the catching of cattle. The Peon fastens one end of his lazo (or noosed thong) to the girth of his horse, who soon learns to place himself in such an attitude as to draw the ox which his rider has caught, and even should the latter dismount, he keeps the thong on the stretch.

The horses in this country are very spirited, and perform almost incredible labour. They seldom work longer than a week at a time, being then turned out to pasture for months together. Their sole food is grass, and the treatment they meet with from their masters is most harsh and unfeeling. They are frequently galloped until their generous fire is spent, and they drop through exhaustion and fatigue. The make of the bridle is alone sufficient to torture the animal, being of the heavy Spanish fashion. They are never shod. The girths of the saddles are of a curious construction; they are generally formed of shreds of green hide, or of the sinew of the neck; the middle part is twenty inches broad, terminated at each end by an iron ring. One of these ends is made fast to the saddle by its ring; to the other side of the saddle is attached a third ring and a pliable strap, which, being passed through it and the girth-ring three or four times, affords the rider great purchase, and enables him to gird the saddle very tight, which is thus kept so firm in its place that a crupper is unnecessary, and indeed is never used.

Trained horses are here from five to seven dollars each ; horned cattle, in good condition, by the herd of a thousand at two dollars a head ; mares at three rials (1s. 6d. sterling) each. Sheep are very scarce and never eaten ; they are kept by some families merely for the sake of their wool, which is made into fleeces for bedding. It is worthy of remark that in the remote parts of the interior, where no settlements have been made, the cattle are found of a dark dirty brown colour, except on a small part of the belly, which is white, but when they become domesticated they produce breeds of a lighter colour, with hides beautifully spotted and variegated. The fine herds bred in many parts of this district have often tempted the Portuguese to make predatory incursions, and the country being accessible by fine open passes to the frontier, as well as to the north side of the Plata, these violations of territory have been carried on to a very serious extent. So frequent were they at one period that it became necessary to appoint a military force to parade the boundaries and to defend the Spanish settlements against these inroads.

In taking a general view of the country, a stranger cannot but observe, with regret, that while nature has been profuse in her blessings, the inhabitants have been neglectful in the improvement of them. Here is, for instance, abundance of excellent clay and plenty of wood on the margin of the rivers, yet it is rare to meet with an inclosure, even for a kitchen garden, much more so for a corn-field. They generally choose their grounds for tillage by the bank of a rivulet, so as to have one side or sometimes two sides bounded by it ; the remainder is fenced in the most clumsy and bungling manner imaginable. Ploughing is performed by the help of two oxen yoked to a crooked piece of wood, about four inches in diameter, and pointed at the end. After the ground has been rooted up, the wheat is sown, without any previous attempt to clear it from noxious seeds. While it grows up, it is never weeded ; so that wild oats, poppies, and other pernicious herbs, thriving among

it in thick luxuriance, obstruct the sun's rays and hinder it from ripening kindly. Indian corn, beans, melons, &c. are all treated in a similar way. The wheat, when ripe, is cut down with sickles and gathered into heads or sheaves. A circular pen of from 40 to 60 yards in diameter is then formed with rails and hides; in the centre of this enclosure is placed a quantity of about 100 or 200 quarters of wheat in the straw. The pile is so formed as to have the ears on the outside as much as possible. A small quantity is pulled down towards the circumference of the circle, and a herd of about twenty mares are driven in, which, being untamed, are easily frightened and made to gallop round. At this pace they are kept by means of whips for four or five hours, until the corn is trod out of the ears, and the straw is completely reduced. Another parcel of the sheaves is then pulled down, and a fresh herd of mares is let in, and this operation is repeated until the whole heap is reduced, and the straw is broken as small as chaff. In this state it is left until a brisk wind happens to rise; and then the winnowing is performed by emptying baskets of the mixed grain and chaff at an elevation of eight feet from the ground. While the chaff is borne away by the current of air, the grain falls, and at the close of the operation, is sewed up in green hides. In this state it is sent to the sea-ports, where a considerable quantity of biscuit is prepared for shipping. It is obvious, that by the above mode of separating the grain, a considerable quantity must be lost by abrasion, and by mixture with a large portion of earth which cannot be blown away by the wind.

The climate and soil are equally favourable for the growth of grapes, apples, peaches, and in short every species of fruit belonging to the temperate zone, but these are known here only as rarities. That inestimable root, the potatoe, would thrive abundantly, if once introduced; but, though much has been said in recommendation of it, the people remain totally averse to this or any other proposal for improving their means of subsistence, and seem to wish for nothing beyond the bare necessaries of life. Indeed the state of

society among them weakens: those ties which naturally attach men to the soil on which they are accustomed to subsist. The Peons, brought from Paraguay in their infancy, grow up to the age of manhood in a state of servitude, uncheered by domestic comfort; at that period they generally wander in search of employment toward the coast, where money is in greater plenty. They are for the most part an honest and harmless race, though equally as liable, from the circumstances of their condition, to acquire habits of gambling and intoxication*, as the higher classes of the people, numbers of whom fall victims to those seductive vices. The various evils hence resulting are multiplied by the lax administration of the laws; even in case of murder the criminal has little to fear if he can escape to a distance of twenty or thirty leagues; he there lives in obscurity, probably for

* Such is their excessive propensity to gambling, that they frequently carry cards in their pocket, and, when an opportunity occurs, form parties, and retire to a convenient place, where one of them spreads his pancho or mantle on the ground, in lieu of a table. When the loser has parted with his money, he will stake his clothes, so that the game generally continues until one of them goes away almost naked. This bad practice often leads to serious consequences. I once observed a party playing in the neighbourhood of a chapel after mass had been said, when the clergyman came and kicked away the cards in order to put an end to the game. On this one of the Peons rose up, and retiring a few paces, thus accosted the intruder: "Father, I will obey you as a priest; but" (drawing his knife) "you must beware how you molest our diversion." The clergyman knew the desperate character of these men too well to remonstrate, and retired very hastily not a little chagrined.

On another occasion a party of Peons were gambling with a Spanish corporal in the prison-yard, when a dispute arising, the latter drew his sword on his unarmed antagonist, and wounded him so severely in the arm, that he was obliged to undergo amputation the day following.

It is usual for a Peon who has been fortunate at play, to go to Monte Video and clothe himself anew in the shop of a slop-seller. While the man is looking out the articles he calls for, he deliberately places his dollars on the counter, in separate piles, assigning each to its destined purpose. He then retires to a corner, and attires himself; an unfortunate comrade invariably attends him, who examines his cast clothes, and, if better than his own, puts them on. After passing a few days in idleness, he sets out on his return home, where he appears in his new dress.

the remainder of his life, without ever being brought to justice. I know not whether this want of vigilance in the magistracy be not a temptation for the numerous refugees who seek shelter here, such as European Spaniards, who have deserted from the service or have been banished for their crimes. These wretches, loaded with guilt, flee into the interior, where they seldom fail to find some one or other of their countrymen who is willing to give them employment, though frequently at the peril of his life. By the corrupt example of these refugees, the innocent Creolian is soon initiated in vice, and becomes a prey to all those violent passions which are engendered and fostered by habitual intoxication.

The common dress of the people is such as might be expected from their indolence and poverty. They generally go without shoes and stockings; indeed as they rarely go on foot, they have seldom occasion for shoes. Some of them, particularly the Peons, make a kind of boots from the raw skins of young horses, which they frequently kill for this sole purpose. When the animal is dead, they cut the skin round the thigh, about eighteen inches above the gambrel; having stripped it, they stretch and dress it until it loses the hair and becomes quite white. The lower part, which covered the joint, forms the heel, and the extremity is tied up in a bunch to cover the toes. These boots, when newly finished, are of a delicate colour, and very generally admired. The rest of their apparel consists of a jacket, which is universally worn by all ranks, and a shirt and drawers made of a coarse cotton cloth brought from the Brazils. Children run about with no dress but their shirts until their fifth or sixth year. Their education is very little attended to, and is confined to mere rudiments; a man who is able to read and write, is considered to have all the learning he can desire.

Among the many natural advantages which this district possesses, are the frequent falls in the rivulets and larger streams, which might be converted to various mechanical purposes, if the population were more numerous and better instructed. Some of these streams, as

was before stated, join the various branches of the Godoy, and flow into the lake Meni; those on the other side the mountains in a northerly direction empty themselves principally through the Riachuelo and the St. Lucia, into the Plata.

The want of cultivation in this vast territory may be inferred from the numbers and varieties of wild animals which breed upon it. Tigers, ounces, and lions are common. The former are heavy sluggish animals; their chief prey is the young cattle, which they find in such abundance that they rarely attack a man. Hence little danger is to be apprehended from them by any person travelling on horseback*, unless when inadvertently approaching the haunt of a female with young. The ounce has the same character, and the lion is considered less vicious than either. There is an animal of the pig kind, called the pig of the woods, which has an aperture on its back, whence it emits a most intolerable stench

* Among the many daring and active feats performed by the Peons, one of the most extraordinary of late years, was the capture of a tiger by a female of that tribe. She was a mulatto-woman, brought up in the vicinity of Barriga Negra. She was accustomed at an early age to ride horses, and prided herself in doing offices which belonged to the stronger sex, such as catching cattle with the noose, killing them, &c. Her form was masculine, and she became so inured to men's work, that she was hired as a Peon, and fulfilled that office much to the satisfaction of her employers. She was noted for selecting spirited horses, and for riding them at full speed. One day on her return from labour, as she was passing a rivulet, she observed a large tyger at no great distance. Surprized that the animal did not steal away, as is generally the case when he sees a person mounted, she drew nearer, still keeping her horse's head from him, so as to be ready to gallop off if he should make a spring. He was still inattentive and motionless; the woman observing this, and thinking he ailed something, after some minutes' pause backed her horse until she came within twenty yards of him, loosening at the same time her noose from the saddle, which she threw most dexterously over his neck, and immediately galloped away with him to a considerable distance. Whether ill or not before, she knew he must now be dead; she therefore alighted, flayed him, and carried home the skin as a trophy. The animal was above the ordinary size, and not smaller than a calf of six weeks old. This exploit was long the talk of the neighbourhood, and I have heard the woman herself relate it.

when closely pursued. If on killing the animal, the part be instantaneously cut out, the flesh affords good eating, but should that operation be neglected, even for a short period, the taint contaminates the whole carcase. The domestic pigs are by no means good; they feed so much upon beef that their flesh is very hard and coarse. There is an animal of the opossum kind, about the size of a rabbit, called a zurilla, the skin of which is streaked black and white, and is considered of some value. When attacked, it ejects a fetid liquor, which is of so pungent a nature, that if it falls on any part of the dress of its pursuers, there is no possibility of getting rid of the stench but by continual exposure to the weather for some months. The zurilla is very fond of eggs and poultry, and sometimes enters a house in quest of its prey; the inhabitants immediately hasten out and leave their unwelcome visitant in quiet possession as long as she chooses to stay; well aware that the slightest attempt to drive her out, would expose them to an ejection from the premises for ever. Eagles both of the grey and blue species, as well as other birds of prey, are found here in great numbers. Here are also parroquets in immense flocks, pigeons, great red-legged partridges, small partridges, wild ducks, and wild turkies. Ostriches of a large species are very numerous; they are so fleet and active that even when well mounted I could never get near them but by surprise; the stroke of their wing is said to be inconceivably strong.

Here are considerable herds of small deer, which in this fine country would afford the sportsman excellent diversion, but unfortunately the dogs are good for nothing, as there is no attention paid to the preservation of the breed. The rivers produce tortoises and other amphibious animals, but they are chiefly noted for a variety of singularly ugly fish, which afford tolerable but by no means good eating.

During a residence of six months in this remote district, as a prisoner at large, or in fact as a welcome guest at the house of a most hospitable man, my life passed away in an equable tenour, un-

interrupted by those vicissitudes that elsewhere befel me, and therefore a narrative of it is little calculated to interest the Reader. Rather than occupy his attention by relating my various hopes and disappointments as the prospect of liberation became more or less favourable, I have chosen to present him with the result of some general observations on the country, made during the daily excursions which I enjoyed through the liberality of my friend. The longer I resided in his house, the greater was his kindness to me in allowing me those indulgences, and the more did he and his family strive to render my exile agreeable. An event at length occurred which at once delighted and distressed me, because while it afforded me hopes of immediate deliverance, it destroyed for a time the harmony which so long subsisted between me and my protector. I allude to the taking of Monte Video by the British troops under Sir Samuel Auchmuty.

On hearing of the surrender of the place, I solicited Mr. Martinez to liberate me, as I thought myself no longer a prisoner. He seemed much astonished at this, and gave me to understand that I continued a prisoner, because, not being actually at Monte Video, I was still in the power and under the jurisdiction of the Viceroy of Buenos Ayres. This worthy man's mind was so distracted by the fall of the town, and by the disgrace of the Spanish arms, that he secluded himself from society, and avoided all communication with me. Under these circumstances I was advised to attempt my escape, but I felt great repugnance at the idea of thus wounding the feelings of a man who had humanely released me from confinement, and had ever treated me as a brother. Averse to such an act of ingratitude, I intreated his amiable wife to intercede for me, and to suggest that, on returning to Monte Video, it might be in my power to be of service to him. But he rejected the proposal in the most vehement manner, and forbade any one to talk to him on the subject. I now thought that my liberty was unreasonably denied me, and as I saw no probability of obtaining it but through my own

exertions, I determined at all events to make the attempt. After deliberating for some days, and consulting with two men who had frequently mentioned the subject to me, I decided on my plan of escape, and gave them six ounces of gold to provide horses and every thing necessary. On the appointed night, all was in readiness, the horses were saddled, and the men waiting to escort me. This moment was one of the most melancholy in my life; I reflected with compunction that, while striving to regain my freedom, I was apparently abusing the confidence of a man of honour who had done all in his power to merit my friendship. Agitated by these emotions, and oppressed by a sadness which the thick gloom of the night rendered more heavy, I was walking to and fro in the neighbourhood, on the spot appointed for my guides to meet me, when a voice, to which I was familiar, accosted me. The person was very near me, but owing to the extreme darkness I could not see him. He asked me what I was doing there. I replied, "only walking about." "Don Juan," said he, "you are going to escape to night." I answered, "indeed I am not." He replied, "you are; and the men whom you have chosen for your guides are to murder you, to seize your money, and to bury you in a ravine about a league distant. The man in whom you have most confided has a knife concealed in his saddle, with which he is to give you the fatal blow." This so staggered me that I was unable, at the moment, to make any answer. I felt confident that no one knew of my intended departure, except the two men and myself. On asking, "how do you know this?" he replied, "I overheard them talking of it." He added, "you know they are both gamblers, and one of them killed two men last year." Ere I had recovered my surprise, so as to speak again, the man went away. While meditating on the choice of evils, namely, whether to run the risk of being murdered and thrown into a ravine, or to abandon my design and remain a prisoner, one of my hired Peons came to inform me that the horses were waiting. I told him I had a violent pressure at my stomach

and could not ride. He treated this very lightly, and urged me with great earnestness to mount at all events. Considering at this moment that money was of little value in comparison with my life and liberty, I offered to give him two ounces of gold if he would perform a piece of service for me, which I would explain to him through my room window at midnight. He still used every argument to persuade me immediately to set out, but finding that I persisted in alledging my indisposition as an excuse, he at length acceded to my proposal. Having reached my chamber, I wrote to a magistrate in Monte Video, who, I knew, would, if he had survived the assault of the town, send an order for my liberation. Having finished writing, the man appeared at the window according to agreement; I gave him the letter, charged him to convey it to Monte Video, and presenting him with two ounces of gold, promised him another ounce if he should bring me an answer. He departed unknown to any of our good family, and on the fifth day following, in the forenoon, returned, to my inexpressible joy, with a paper signed by Sr. Francisco Juanico, the magistrate to whom I had written, stating that I was free, and ought immediately to proceed thither. On receiving this welcome intelligence I hastened to Mr. Martinez, and joyfully embracing him, gave him the paper to read; after examining its contents, he observed, that it was nothing official, but would avail me as a reasonable pretext for going away, to which he cordially acquiesced. He immediately ordered three Peons and a trusty old Creolian to accompany me, with twenty-five horses, that we might perform the journey with greater expedition. The best dinner was provided which the time would allow, and while partaking of it I received the sincerest congratulations on my liberation from my worthy host and his amiable lady. I then took an affectionate leave of every branch of this good family, expressing my warm acknowledgments of the many obligations they had conferred on me. Having joined my guides, we each mounted a horse, and, at three in the afternoon, set off at full speed, driving

the rest of the cattle before us. My first horse bore me forty miles, and I changed him at ten o'clock. The night was fine, and after a rapid but pleasant journey, we forded the river St. Lucia and halted at two in the morning, half way on the route to Monte Video. At the house, into the corral of which our horses were driven for the purpose of changing them, I procured a slight repast of dried figs, after which we again mounted and travelled tolerably fresh until six in the morning, when we were again obliged to change, having proceeded about one hundred English miles. Our horses now began to lose their generous spirit, and were very much distressed. As our progress became slower and our changes more frequent, my anxiety increased, because I was aware there were Spanish parties scouring the country about Monte Video, and stopping the passage of all provisions from the interior. To avoid suspicion I rode in the dress of a Peon, with the lazo coiled up and hung at my saddle. At eleven o'clock the heat of the day became oppressive, and our horses flagged exceedingly. To add to my distress I had a violent hæmorrhage from the nose, and could obtain no water to drink or wash with, so that, through thirst and the coagulation of blood, I was nearly suffocated. On arriving within twelve miles of Monte Video our horses were nearly worn out; but no rest could be allowed for either them or the men. At noon we reached an English picquet-guard on the outposts; after the usual questions I was conducted by a soldier to the officer, to whom having explained some particulars, I rode to General Lumley's tent, and afterwards into the town.

No language can describe my emotions on beholding an English flag on that tower in which I had been so often confined, and on seeing English soldiers in possession of a place where I had experienced so much injustice and oppression. The joy I felt made me forget my fatigue and the dangers I had passed through. I rode up to my friend's house; all was barricadoed, and I feared the worst might have happened; but on advancing to the window I observed

one of the ladies, who instantly recognized me. All the family welcomed me most cordially, and invited me to dinner, after which I went, in my Peon's disguise, to visit some of my friends. On taking possession of Mr. Martinez's house, I found my chests, &c. undisturbed, and in the same condition as when I left them on going into the country.

CHAP. III.

Expedition against Buenos Ayres.—Causes of its Failure.—Account of the Population of the Country, and of the various Classes which compose it.

WHEN the expedition against Buenos Ayres was ready to sail, I obtained General Whitelocke's permission to go with the army under the hope of recovering the property I had in that city, and offered my service to the commissary-general, whom I accompanied. On our arrival at the place of disembarkation I was surprized to learn that the army was totally destitute of guides, and almost equally so of Peons, whose assistance was highly desirable in catching and driving cattle for the subsistence of the troops. The commander in chief, whom I met with on the beach, expressed great chagrin at the false information he had received on this and other particulars. He had been led to expect a landing-place where the men would not wet their shoes;—here they were up to the breasts in water: he had been told that guides would offer themselves in whole troops on this side the river;—not one was to be seen. Early on the morning after we had landed, I was requested by an officer to assist in obtaining guides, and the difficulty we had in the search fully exposed the oversight which had been committed in neglecting to secure a number at Monte Video. Some useful persons there had offered themselves, and only required to be ostensibly pressed into the service in order to avoid the ignominy which might have awaited them had they openly volunteered. After much trouble an aged negro was found, who was compelled to guide the army on its way to Buenos Ayres. The difficulties that occurred on the march in passing swamps, fording rivers, &c. have been already

laid before the public, in the report of General Whitelocke's trial, and I believe the evidence recorded in that statement will bear me out in saying, that these difficulties were in great part attributable to the glaring omission above-stated. Previous to our advance to Quilmes, a place four leagues distant from Buenos Ayres, the commissary-general requested me to undertake the management of the few Peons we had, in order to procure provisions for the troops. In this service I found myself of some use, though no exertion could repair the neglect which was observable in a department so essential to the army. The enemy drove the cattle away wherever they could, and our Peons found the duty extremely harrassing and perilous, for they were frequently chased by the Spaniards and driven within our marching columns. A small detachment of riflemen was sent out to cover their excursions, and the service was afterwards more effectually performed. On our arrival at Quilmes, after many disagreeable encounters, the soldiers were excessively fatigued; upwards of two hundred of them could march no farther. The centre division, commanded by General Whitelocke, quitted this place without any person conversant with the country to act as guide, and on halting, after a march of four or five hours, they found that, instead of having followed the route of the advanced division, under General Crawford, they had taken a circuit to the left, and were almost as far from Buenos Ayres as when they set out. I accidentally met the General while I was riding about giving directions to the Peons; and on speaking with him he expressed great irritation and disappointment at the situation in which he found himself. The next morning the division advanced, and crossing the Riachuelo, joined that of General Crawford, about four in the afternoon, when we were informed of the skirmish that had taken place, and of the cannon that had fallen into our hands.

It is by no means improbable that the fate of the expedition was decided by the delay which took place in the junction of the centre with the advanced division; for, had they joined the day

before, they would most probably have entered the town immediately, while part of the enemy's forces were out of it, and unprepared. This delay, though short, gave the latter time to entrench and fortify their streets, and to post themselves in the most advantageous stations.

During the few days we were in possession of the suburbs I was requested to take charge of the Pulperias (houses where liquor is sold), in order to prevent the soldiers from getting intoxicated. I had a serjeant and a small party of soldiers under my directions, and placed sentinels where I thought proper. While engaged in this service I had it in my power to render assistance to many families who had fled hither from the town for refuge. Many of the houses I found filled with females, almost frightened to death; to these I gave such protection as my influence over the soldiery enabled me to offer, and supplied them with provisions by means of the Peons.

It was afterwards determined to enter the town; the misfortunes attending that rash attempt are too notorious to need repetition here. A capitulation was signed by our chiefs, and an armistice took place during the fulfilment of the terms. In fact the situation of our army was so critical, that they were obliged to accede to the conditions dictated by the enemy, or perhaps eventually to become prisoners at discretion. The restoration of Monte Video was the stipulation most to be regretted, for every principle of good policy required us to keep that town to the last extremity, nay some of the best-informed among the Spaniards were of opinion, that our army should have been contented with the possession of the north side of the Plata, without venturing any farther, because we should thus have commanded the trade of the interior, and Buenos Ayres would in the end have found it necessary to come to terms of accommodation highly to our advantage*.

* It is with great regret that I mention the ill-requital which the Peons met with from our army. They had been promised great rewards for their activity in driving cattle and securing provisions during the march, and for their great services as messengers. After the

After the army had reembarked for Monte Video, I remained a few days to forward some business for the commissary, and to attend to my own. It was gratifying to me to find that the services I had an opportunity of rendering to those families that had taken refuge in the suburbs during the siege were not forgotten; they all strove which should be foremost in testifying their acknowledgments by every polite attention which it was in their power to shew me.

My short stay at Buenos Ayres did not afford me time to make any geological researches; indeed the country behind it, being a vast plain, without any traces of rock, did not offer much scope for such an undertaking. With the exception of a part of the bank near the mole, which is of granite, I scarcely found an indurated substance during the whole route. Judging from the shells and other marine productions which are occasionally found in the Pampas, I should conclude that those extensive level districts have formed, at some period, the bottom of the river, and that they have been left dry by the progressive precipitation of matter and the deepening of the Rio de la Plata in its present channel through a long course of ages. A circumstance which seems to support this conjecture is, that the land continually gains upon the river, and that at those times, when the wind blows from the Pampas, a considerable extent of the bank on the side of Buenos Ayres is left dry.

capitulation was signed, as they were accompanying a waggon full of our wounded from the corrals of Miserere to the Retiro, a place assigned for our re-embarkation, they were met and recognized, in their disguise, by a party of Spaniards, who, suffering the waggon to pass, carried these unfortunate men to prison. Hearing of this I made repeated applications to the Commissary-general to induce him to procure their liberation; he assured me that he had represented the matter to the Commander-in-chief, who had promised to attend to it. The men, however, never were liberated; some were executed, and others condemned to hard labour. Thus not only were they disappointed of their reward, but abandoned in their hour of need by the men on whose good faith they had relied, and whose cause they had zealously served. The Commander-in-chief might have obtained their discharge by making a spirited remonstrance, but he omitted to do so, and was very generally accused for this unfeeling neglect; the Spaniards themselves spoke with indignation of our inhumanity in leaving these poor men to be punished as traitors.

The population of Buenos Ayres and its immediate suburbs, exclusive of the country in its vicinity, has been ascertained to amount to upwards of sixty thousand souls. The proportion of females to males is said to be as four to one, but if we take into consideration that many men are almost daily arriving from Europe, as well as from the South American provinces, and that under the old government neither the militia nor the marine was recruited from the mass of the population, we shall find reason to conclude that the proportion of the sexes is not so unequal. In the interior the excess of males is very great, for as the lands are granted in large tracts only, and but poorly cultivated, there is no encouragement for the labouring classes to marry and settle upon them. The poor are compelled to remain single from the very bare resources on which they depend for subsistence, and are accustomed to consider the married state as fraught with heavy burthens and inevitable misfortunes. It is not uncommon to find estates larger than an English county with hardly more than a hundred labourers upon them, who subsist upon the sale of a little corn, which each is permitted to grow for himself, but only to such an extent as a single man can plough.

The various races which compose the population are as follow ;

1. Legitimate Spaniards or Europeans. In Buenos Ayres there are about three thousand ; in the interior the number is very trifling, except in Potosi, which, being a mining country, contains many.
2. Creoles ; legitimate descendants from Spaniards or Europeans.
3. Mestizos, the offspring of European and Indian parents.
4. Indians, almost all of whom have some mixture of Spanish blood.
5. Brown mixtures of Africans and Europeans.
6. Mulattos of various degrees.

All these races intermix without restraint, so that it is difficult to define the minor gradations or to assign limits to the ever-multiplying varieties. Few families are entirely exempt from characteristics of

Indian origin, physical as well as moral. It is well known that in the Spanish colonies little regard is now paid to purity of blood; the various regulations for preserving the races distinct have gradually become obsolete. This may be regarded as a momentary evil; but may it not be conducive in the long-run to the good of society, by concentrating the interests of the various classes, which in remaining separate might one day endanger the stability of the government, as has been the case in the French colony of St. Domingo?

In describing the orders of society in Buenos Ayres, it is necessary to premise that I mean to class them, not by degrees of birth, rank, or profession, but by the relative estimation in which they stand in point of property or public usefulness.

According to this scale, the first which comes under consideration is the commercial class. Every person belonging to it, from the huckster at the corner of the street, to the opulent trader in his warehouse, is dignified by the appellation of merchant, yet few individuals among them can lay just claim to that title, as they are wanting in that practical knowledge so essential in commercial dealings. They are averse to all speculation and enterprise; the common routine of their business is to send orders to Spain for the articles they need, and to sell by retail at an exorbitant profit; beyond this they have hardly a single idea, and it has been said that their great reason for opposing a free trade with foreign nations is a consciousness of their own mercantile inexperience. The more considerable houses are almost all branches of some European establishment; few of the Creoles have any regular trade. Those among them however who engage in it are much more liberal in their transactions than the old Spaniards, and are observed to make less rapid fortunes, for their manly and independent character makes them spurn a miserable economy, and disdain to assume that church-going hypocrisy which must be practised twice or thrice a-day by those who would enrich themselves through the patronage of the opulent families. Among the inferior tradesmen, those who gain most are the pulperos, the ware-

housemen, and the shop-keepers. The pulperos retail wine, brandy, candles, sausages, salt, bread, spices, wood, grease, brimstone, &c. Their shops are generally lounging-places for the idle and dissipated of the community. In Buenos Ayres there are about seven hundred of them, each more or less in the interest of some richer individual. The warehousemen sell earthen and glass ware, drugs, various articles of consumption, and some goods of home-manufacture, wholesale and retail. The shop-keepers amount to nearly six hundred in number ; they sell woollen cloths, silks, cotton goods of all sorts, hats, and various other articles of wearing apparel. Many of them make considerable fortunes, those especially who trade to Lima, Peru, Chili, or Paraguay, by means of young men whom they send as agents or factors. There is another description of merchants, if such they may be called, who keep in the back-ground and enrich themselves by monopolizing victuals, and by forestalling the grain brought to market from the interior, much to the injury of the agricultural interest.

The second class of inhabitants consists of the proprietors of estates and houses. They are in general Creoles, for few Europeans employ their funds in building, or in the purchase of land, until they have realised a fortune to live upon, which commonly takes place when they are far advanced in life, so that their establishments pass immediately into the hands of their successors. The simple landholders derive so little revenue from their possessions, that they are generally in debt to their tradesmen ; their gains are but too commonly engrossed by the monopolists, and having no magistrate to represent them, they find themselves destitute of effectual resources against wrong and extortion. So defective and ill-regulated are the concerns of agriculture in this country, that the proprietor of an estate really worth 20,000 dollars can scarcely subsist upon it.

Under the class of landed proprietors I may reckon the cultivators, here called *quinteros* or *chacareros*, who grow wheat, maize,

and other grain. These men are so depressed and impoverished that, notwithstanding the importance of their calling, and the public usefulness of their labours, they are ranked among the people of least consequence in society.

The third class is composed of handicraftsmen, such as masons, carpenters, tailors, and shoe-makers, who, although they work hard and receive great wages, seldom realise property. The journeymen are usually people of colour; the masters for the most part Genoese, and universally foreigners, for the Spaniards despise these trades, and cannot stoop to work along with negroes or mulattos. Many of the lower orders derive subsistence from these and other employments of a similar nature; here are lime-burners, wood-cutters, tanners, curriers, &c. The free porters constitute a numerous body of men; they ply about the streets to load and unload carts, and carry burdens, but they are so idle and dissolute, that no man can depend on their services for a week together; when they have a little money, they drink and gamble, and when pennyless, they sometimes betake themselves to pilfering. These habits have long rendered them a public nuisance, but no corrective measures have hitherto been taken, nor does there appear, on the part of the higher orders, any disposition to reform them.

Persons employed in public offices may be comprehended under the fourth class. The best situations under Government are held by native Spaniards; those of less emolument by Creoles; the former are regarded as mere sinecures, and the persons enjoying them are considered as in no way serviceable to the community except by spending their large salaries within it.

The fifth class is the militia or soldiery. Previous to the invasion of the English, the officers were not much noted for military science, or for that ardour which leads to the acquisition of it; their chief ambition was to obtain commands in towns and villages, especially those on the Portuguese frontier, where they

might enrich themselves by smuggling. The privates were ill-disciplined, badly dressed, and badly paid. The effective force which the crown of Spain maintained in these possessions was one regiment of the line, which was to consist of 1200 men, but was reduced to less than half; one regiment of dragoons amounting to 600, two of cavalry called blandengues, 600 each, and one or two companies of artillery. With the exception of the blandengues, all the troops were originally sent from the Peninsula, but not having for the last twenty years been recruited from thence, their ranks were gradually filled by natives. By eminence they were called veterans, but they have been of late disbanded, and their officers have passed to the command of the new corps which were formed on the English invasion. The force of these corps may be estimated at nine thousand men.

The sixth class is the clergy, in number about a thousand. The seculars are distinguished by their learning, honour, and probity from the friars, who are in general so grossly ignorant and superstitious, that they render no real service to the public in any way, but rather tend to disturb the minds of the honest and well-disposed.

Every observation I was able to make gave me a favourable idea of the general character of the people: they are tractable, prudent, and generous; and doubtless, had they been under a milder and more beneficent government than that of the Spaniards, they might have become a model to other colonies; but it is lamentable to add, that in points of morality they cannot be considered as much superior to the other inhabitants of America. This is attributable to the want of a proper system of education for youth, to the pernicious example afforded by the vices of the Europeans, and, in a word, to the prevalence of an intolerant system, which, by aiming to make men what they cannot be, cause them to become what they ought not to be. The excessive rigour exercised by the ministers of worship as well as by the government, for

the suppression of immorality, defeats its own end ; it is like the unskilful practice of a physician, which, directed solely against the external symptoms, aggravates instead of removing the disease. Thus, while open profligacy is discountenanced in Buenos Ayres, libertinism of a more dangerous kind is connived at, if not tolerated ; the peace of the most respectable private families is liable to be destroyed by votaries of seduction, who respect neither the purity of female virtue, nor the sacred rights of matrimony. This evil pervades all classes of society, and is the source of domestic disputes, which often lead to serious consequences.

In thus attempting to describe the state of Buenos Ayres as I found it in the year 1807, I have purposely avoided all discussions of a political nature, and have declined entering into a detail of the events which led to the present struggles of the people for independence. Circumstanced as I then was, I had no means of procuring correct and impartial information on the subject, but since my return I have been favoured with a communication, containing a brief history of the Revolution, by a gentleman whose official situation at Buenos Ayres afforded him the amplest opportunities of observing its rise and progress. This communication interested me so much that I solicited and obtained permission to annex it to this work in a detached form, and I submit it to the public under the impression that its authentic character, and the spirit of moderation which it breathes, will ensure to it a candid and favourable reception*.

* See Appendix A.

CHAP. IV.

Voyage to St. Catherine's. — Description of that Island, and of the Coast in its Vicinity. — Arrival at Santos, and Journey thence to St. Paul's.

ON my return to Monte Video, I lost no time in putting in execution my purposed voyage to Rio de Janeiro ; and as advices had arrived, stating that considerable difficulty might attend the entrance of an English ship into that port, I bottomried a Portuguese vessel, called the *Vencedor*, and was joined by a party of gentlemen whose business required them to visit the capital of Brazil.

In the beginning of September 1807, we had just embarked our stock for this voyage, when an order for the immediate evacuation of Monte Video by our troops was unexpectedly issued. As it had been generally believed that a prolongation of the time for giving up the place had been agreed on, the greatest hurry and confusion prevailed in embarking the troops and stores, as well as the baggage of individuals. About mid-day the whole was on board ; a signal-gun was then fired for the Spanish troops to enter, and about three in the afternoon we had the mortification to behold their flag hoisted on the ramparts of this important military post and commercial depôt, which the British forces had, a short period before, so bravely and so dearly won.

Having still some purchases to make, I returned on shore, with two of my friends, about four o'clock, but we had soon reason to repent of our temerity, for on passing the mole we were noticed as enemies and threatened severely, so that we found it necessary to pass into the more private streets in order to avoid the malignant

and hostile taunts of those very men who had of late expressed themselves our friends and well-wishers. Desirous of expediting our several affairs as much as possible, we separated, and I was not able to rejoin my companions until eight in the evening. I found them in great anxiety for my safety; the Spaniards had fired a feu-de-joie from the citadel and fort St. Joseph, and were now preparing for bonfires * and illuminations, and my friends, though they did their utmost to avoid the riotous crowds that paraded the town, had several narrow escapes from being plundered and stripped by the soldiery. We all got safely on board by ten o'clock, congratulating each other on having happily avoided the dangers to which our rash confidence in the amicable disposition of the inhabitants had exposed us.

On the 11th of September we sailed from the Rio de la Plata; the vessels bound for the Cape of Good Hope were then nearly out of sight, and as we beheld them we felt a melancholy but proud delight in reflecting that, after such grievous and unexpected reverses, our brave countrymen were once more within their wide undisputed empire, the ocean. After a voyage, in which nothing worth relation occurred, we made the island of St. Catherine's on the 29th, at sunrise, and were delighted with a grand and pictureque view of its conical rocks rising abruptly from the sea, embellished with the lofty mountains of Brazil, covered with wood in the back-ground. This sublime scenery interested us the more from the contrast it formed with the extensive and woodless plains of Buenos Ayres. This island is situated in 27 and 29° south latitude, and is separated from the continent by a strait, in some places not half a league wide.

* One mode which they adopted for displaying their triumph over their late conquerors was singular enough; they collected all the sign boards belonging to the English warehouses and shops, and made a bonfire of them. A great quantity of these boards were from the pulperias, the masters of which had been obliged to have on them the following inscription, painted in large characters, "Licensed to sell liquor."

Entering the port of St. Catherine's by the north, we passed several islands, on one of which, westward of the entrance, stood the respectable fort of Santa Cruz. After running a few miles in shoal water, we sailed into a narrow passage guarded by two forts, which forms the harbour. From the anchorage, and more particularly from the landing-place, which is at the bottom of a verdant slope of about five hundred yards, the town has a most beautiful appearance, and the perspective is nobly crowned by its fine cathedral. The green is interspersed with orange-trees, and forms an agreeable parade. Immediately on entering the town, we discerned in its general appearance, and in the manners of its inhabitants, a striking superiority over those which we had of late visited. These houses are well built, have two or three stories, with boarded floors, and are provided with neat gardens, well stocked with excellent vegetables and flowers. The town consists of several streets, and may contain from five thousand to six thousand inhabitants. It is a free port. The produce of the island consists in rice, maize, mandioca, coffee of excellent quality, oranges, perhaps the finest in the world, and a variety of other fruits. Sugar and indigo are likewise produced, but in small quantities. A profusion of the finest flowers indicates the genial nature of its climate; the rose and the jessamin are in bloom all the year round.

The surface of the island is varied with mountains, plains, and in some places swamps; here is found a stratum of excellent red clay, which is manufactured into jars, culinary vessels, large water-pots, &c. which are exported in considerable quantities to the Plata and to Rio de Janeiro. The lands capable of cultivation are under considerable improvement; a great extent of them was formerly covered with large trees, but as great quantities have of late years been cut down and used for ship-building, good timber may now be considered scarce. They grow flax here of a very fair quality, of which the fishermen make their lines, nets, and cordage. The sea hereabouts produces an abundant variety of excellent fish, and some

fine prawns ; so large is the supply to the market, that a quantity of fish, sufficient to dine a dozen persons, may be had for a shilling. Meat is much the same in quality as at Monte Video, being rather hard and lean ; its general price is about three halfpence per pound. Pigs, turkies, ducks, poultry, and eggs, as well as fine vegetables and excellent potatoes, are plentiful and cheap :

The trade of this place is inconsiderable, as the produce does not much exceed the consumption of the inhabitants, who are in general far from rich. It affords an agreeable retirement to merchants who have discontinued business, masters of ships who have left off going to sea, and other persons, who, having secured an independence, seek only leisure to enjoy it. Few places are better calculated for such a purpose than this ; it is enlivened by the numerous coasting-vessels from Bahia, Pernambuco, and other ports, bound for the Plata, which frequently touch here ; and it is amply provided with artisans of all descriptions, such as tailors, shoemakers, tin-workers, joiners, and smiths. The inhabitants in general are very civil and courteous to strangers ; the ladies are handsome and very lively, their chief employment is making of lace, in which they display great ingenuity and taste.

The mountains of the interior, and the rocks on the coast, are of primitive granite. Close to the fort, on the left hand of the entrance to the harbour, is a vein of grüstein in various states of decomposition, which ultimately migrates into clay of a superior quality to that generally found in the valleys. The soil in the interior, being rather humid, is surprisingly fertile. It consists principally of a rich vegetable decomposition, on which shrubs and plants grow in great luxuriance. Myrtles appear in all parts, and a most beautiful variety of the passion-flower is found in equal abundance. Here is also a profusion of roses, pinks, rosemary, &c.

The animals are chiefly opossums, monkeys, and armadillas ; there are various serpents, among which is the beautiful corral snake. Of birds, there are cranes, hawks, parrots, of various species,

humming birds and toucans, the latter of every variety in great numbers.

The climate is serene and wholesome, its solstitial heats being moderated constantly by fine breezes from the south-west and north-east, which are the winds that generally blow here ; the latter prevails from September to March, and the former from April to August, so that a voyage to the north, during one half of the year is slow and tedious.

The island is divided into four parishes : 1st, Nossa Senhora de Dereito ; 2d, St. Antonio ; 3d, Laguno ; and 4th, Riberon. The divisions of the opposite part of the continent are likewise under the jurisdiction of the governor of St. Catherine's, who is subject, in certain cases, to the captaincy of St. Paul's, and in others to the Government of Rio de Janeiro. These divisions, are 1st, St. José ; 2d, St. Miguel ; and 3d, Nossa Senhora de Rosario ; the entire population of the island and its dependencies amounts to about 30,000 souls.

Of the fortresses which defend this island the most considerable is Santa Cruz before-mentioned ; there are four others, Porto Groed, Ratonés, Estreito, and Conceção. Off the former there is safe anchorage for a fleet of men of war, and the harbour which it protects may be entered by ships of 300 tons, if not of a heavy draught of water. Ships passing the channel are required to send a boat on shore at Santa Cruz before they proceed.

To the west of the island, on the opposite coast, is an almost inaccessible barrier of lofty mountains, thickly covered with trees and underwood. At a small port in the vicinity, called Piripi, which has a very pretty river, an immense quantity of fish is caught, dried, and exported. They are extremely fat, and very soon become rancid.

On the continent, opposite the town of St. Catherine's, stands the pleasant village of St. José, the inhabitants of which are principally occupied in sawing timber into planks, making bricks, and growing rice. The net gains of a poor family here are incredibly small, but

the necessaries of life are cheap, and they have few incentives to curtail their present enjoyments for the sake of improving their future fortunes. Near this village is a lovely vale called Picada, thickly studded with white cottages, embosomed in orange-groves and plantations of coffee. The gently-sloping hills which enclose this spot, give a picturesque effect to the bold rugged scenery beyond them. This valley, and others contiguous to it, form the extremities of the territory habitable by the Portugueze, for on the land to the westward, though at considerable distance, dwell the Anthropophagi, here called Boogres. These savages live entirely in the woods, in wretched sheds made of palm-branches, interwoven with bananas. Their occupation is chiefly hunting with bows and arrows, but they frequently employ these weapons in hostilities against their neighbours. A party of them will sometimes way-lay a Portugueze, whose residence is solitary; they have even been known to attack and destroy whole families. No regard to humanity seems indeed to be paid by either party in their encounters; they are mutually bent on a war of extermination.

There is much low swampy land in the island, over which causeways, supported by piles, are made to a considerable extent. These lands, on account of their humidity, are very favourable to the growth of rice. The palm-trees, seen at intervals in every direction, have a very pleasing effect.

Our stay at St. Catherine's was prolonged by some unforeseen circumstances, and we had time to take various excursions into the interior of the island and to the adjacent continent. On one of these occasions I happened to be absent, but the adventures which attended it being rather amusing, I am tempted to relate them in the words of one of my friends who formed the party. "Having hired horses and negroes we set out early in the morning for the river Tavarinha. The road for three leagues lay through thick woods, along which we passed without any material accident, and arrived at the end of our journey about two in the afternoon. We dined

with Captain Leones, who entertained us very hospitably, and would have persuaded us to prolong our visit, but we determined to return that evening over the mountains. We travelled for a league through a level well-cultivated country, clothed with orange-groves and coffee-plantations, and tolerably populous. At sunset we arrived at the foot of the mountains, and began to ascend a steep and dangerous road, in the intricacies of which we were soon bewildered, and had great difficulty to regain the most beaten path, which led homewards. Night suddenly overtook us, and we had still three hours journey over the mountains, without guide or attendant, along a perfectly alpine road, winding on the edge of horrible precipices. In this part of the journey two of us, having advanced a little, the rest of the party were suddenly alarmed by a dreadful shriek which excited great apprehension lest some one should have been precipitated down the gulph, but we were agreeably undeceived soon after by the whole of the party joining us. We now heard a noise like hammers, which proceeded from persons beating cotton, and in a little time arrived at a house where, on enquiry, we were informed that the town was ten miles distant. We were proceeding, when a voice cried out in English, "but will not you stop and have some grog?" It may easily be imagined that to be thus suddenly hailed with one of the most familiar phrases of our native English, while benighted in a strange land, operated like an electric shock upon us; we immediately alighted at the house whence the voice seemed to proceed, and found a Mr. Nunney, the English interpreter, who furnished us with a guide; we now continued our way with greater confidence, and reached the town about midnight. This Mr. Nunney, as we afterwards learnt, receives a dollar per diem during the stay of every English or American ship that touches at this port, whether his services are wanted or not, and by these means, with the profits of the sales of provisions which he makes to such ships, he has acquired a little fortune and a pretty estate. His profits, indeed, are

exorbitant, for he charges the articles 100 per cent. higher than they can be procured at from any other dealer in the place."

While at the town of St. Catherine's, we visited some of the gardens with which its vicinity is embellished. They are laid out with great taste, particularly one belonging to the vicar, another in the estate of the late excellent and able General Soares de Coimbra, and a third the property of Colonel Gama. At Barragros, near the village of St. José, we visited a gentleman of the name of Caldwin, who collects and preserves insects. He showed us his grounds, which occupy a space of eighty-five fathoms along the beach, and extend a mile inland, containing orangeries, coffee, rice, and mandioca, in a fine state of culture. These well-watered plantations, together with a neat house and garden, he offered to sell for a thousand crusados (about 125l. sterling).

This was not the only instance we remarked of the low value of landed property here. About two miles from the town of St. Catherine's, a neat house, a small orangery and ground clear of brush wood, capable of forming a pretty plantation, was offered at 100 dollars. An excellent house, in one of the best situations in the environs of the town, with a garden of about two acres well and tastefully planted, was offered to be sold for 400l. sterling. The building of the house must alone have cost 500l. and it was in perfect condition. In short, money appeared so valuable, that a large landed estate might be purchased for a mere trifle.

Our excursions to the main land were not confined to the districts immediately within the jurisdiction of St. Catherine's. Proceeding northward from St. José we entered some fine bays, the shores of which were studded with houses pleasantly situated amid bananerias, orangeries, and plantations of rice, coffee, and mandioca. After having passed several well-peopled parishes, we arrived at Armasão, a village at the extremity of a bay about nine leagues distant from St. José, and four leagues north of Santa Cruz. This village is a

fishing station for whales, which were formerly very numerous on this coast, and in the bays that indent it. The fishery is farmed by government to a company under the superintendance of a Captain Mor* and a number of inferior officers. About 150 negroes are employed on this station, but the number of whales now caught is not so great as formerly, when the average was three or four hundred in a season. Their conveniences for flinching or cutting up the fish are extensive and well-contrived. Several fine piers project from the shore into eighteen to twenty feet depth of water, on which are erected capstans, cranes, and other requisite machinery. Hither all the fish caught on the coast are brought. The boiling-house, tanks, &c. are far superior to any thing of the kind at Greenland dock, and indeed to all similar establishments in Europe. To give an idea of their magnitude, it is sufficient to say, that in one range there are twenty-seven very large boilers, and places for three more. Their tanks are vast vaults, on some of which a boat might be rowed with ease. We obtained a view of these great works through the civility of the commander of the place, Captain Iacinth St. George, who lives here in a princely style, and possesses a very considerable property, which he diffuses with great public spirit and liberality. All who have visited Armasão can bear witness to his affability and urbanity to strangers.

We crossed this peninsula by a mountainous road of four leagues to the Bay of Dos Ganchos, commonly known by the name of Tejucos. Here land is of little or no value; any one may take as much as he pleases of what is unappropriated, provided he make a proper application for it to the government. We passed two sugar plantations with conveniences for making rum; and observed numerous huts interspersed in the vicinity. The contrary side of this peninsula forms the bay before named. The poor cottages of the people here present a curious picture of rural irregularity; some are built on

* Captain Major.

the summit of conical mountains, the passage to which is frequently obstructed by clouds ; others stand on the sides of gentle acclivities ; but the greater number of them is situated almost in contact with the ocean, which often flows to their very doors. The bay is from two to three leagues across, and extends about the same distance inland ; it is well-sheltered, and affords good anchorage, and fine situations for loading timber, with which the mountainous country around is thickly clothed, and large quantities of which are felled and embarked for Rio de Janeiro and the Plata. Canoes are made here, at a cheaper rate and in greater numbers than in any other part of Brazil. The inhabitants grow rice in considerable quantities, as well as some coffee and sugar, but such is their indolence and poverty that they use only hand-mills, consisting of two horizontal rollers, in manufacturing the latter article.

Into this bay fall several streams formed by the mountain torrents and springs, and two tolerable rivers, the less called Inferninho, and the larger Tigreno. They both flow through low swampy land, subject to inundation, and overgrown with mangroves and an immense variety of trees. The insalubrity of this tract might be corrected by clearing away the underwood and draining the soil, but the arduousness of such an undertaking might deter a more active and skilful people than this. In the rainy season it is inundated to a great extent, and in summer it is infested with terrible swarms of mosquitos and burachala flies, which render it almost uninhabitable.

Along the beach of this bay I found the shell of the murex genus, which produces that beautiful crimson dye, so valued by the ancients. It is here called purpura, and to my great surprise, its use is in some degree known to the natives, one of whom shewed me some cotton fringe, dyed with an extract of it, though ill-prepared. The shell is about the size of the common whelk, and contains a fish, on whose body appears a vesicle full of a pale yellow, viscid, purulent substance, which constitutes the dye. The mode of

extracting it, is to break the shell carefully with a hammer, so as not to crush the fish, and then let out the liquor in the vesicle with a lancet or other sharp instrument. I for greater convenience used a pen, and immediately wrote my initials, &c. on a handkerchief; the marks in half an hour after were of a dirty green colour, and on being exposed to the air a few hours longer, changed to a most rich crimson. The quantity produced by each animal is very small, but quite sufficient for such an experiment. The best time for making it, is when the animal is in an incipient state of putrescency. I have not a doubt that if a sufficient quantity of them were taken, and the dyeing matter, when extracted, were liquified in a small degree with gum-water, a valuable article of commerce might be produced. At least the trial is worth making. The liquid is a perfect substantive dye, and of course resists the action of alkalies.

On the rocks, and in greater abundance on the trunks of old trees, I observed a variety of lichens, some of which produced tints of several shades of colours. The continual decomposition of vegetables here adds greatly to the richness of the soil; it is not uncommon to find trees lying on the ground with their interior substance entirely decomposed, and a great diversity of plants growing on them in high luxuriance. Among the numerous tribes of birds that frequent this region, the aquatic afford good eating, as do also the smaller parrots. The woods are filled with monkeys; and on the banks of the rivers are found capivaras in considerable numbers.

In coasting along this shore it is customary for strangers to visit the chief person in command at every station, whatever may be his degree or rank; he, on being requested, will furnish guides, and afford every assistance in his power. I always experienced the greatest attention and civility from these gentlemen, and have reason to believe that they uniformly pay the same regard to all who visit them for permission to see the country.

Ten leagues north of this place is the fine and capacious harbour of Groupus, with its handsome town; the anchorage is

equally good as in that of Dos Ganchos. The inhabitants here pursue the same mode of living as their neighbours in Tejuços. They have a fine climate, and a soil which yields a hundred-fold for whatever is sown or planted in it, and is noted for its delicious fruits. The cotton of which their common clothes are made is grown, spun, and woven among them; they build their own houses, and form their own canoes, which they are dexterous in managing, and prefer to boats. It may indeed be said that every man is more or less an artizan, but I am sorry to observe that they prefer ease to care and industry, and are by no means so good husbandmen as those of Tejuço. This bay, as far as I could observe, during my short visit to it, presents to the view greater diversity of hills, valleys, and plains than the one before-mentioned. Both are esteemed fine fishing-ground during the whale-season, which is from December to June.

From hence to the northward is the fine harbour of San Francisco, in the bay of the same name. It has three entrances defended by forts; that to the south is most frequented. The land here is very flat for several miles, and the rivers which intersect it are navigable for canoes as far as the base of the great chain of mountains, where a public road, begun at incredible labour and expence, leads over that almost impassable barrier. This road will soon be a work of national importance to Brazil, as through it the finest district in that country, and indeed one of the finest in the world in point of climate, the rich plain of Corritiva, will be connected with the ocean. The ridge of mountains is more than four thousand feet above the level of the sea, and there is a regular ascent for twenty leagues from their inland base, to Corritiva. On this fertile tract are fed large herds of cattle for the supply of Rio de Janeiro, St. Paul's, and other places; here are also bred mules in great numbers. Its soil and air are so genial, that olives, grapes, apples, peaches, and other fruits grow to as rich a maturity as in Europe, though they are here almost in a wild state. It is divided into many parishes, but

its population is small, compared with its extent; a circumstance rather surprising, since every necessary of life is here so cheap and in such great plenty. Its distance from the coast and from the chief towns, and the hitherto bad road, may have contributed to deter settlers; it is principally occupied as a breeding district, and supports no more inhabitants than what are barely competent to manage and tend the cattle, which are chiefly purchased by private dealers, and sometimes by commissioners from government, who come hither occasionally for the purpose. The road from hence to the city of St. Paul's, distant about 80 leagues, is tolerably inhabited, especially in the vicinity of Sorricaba, something more than half way, which is a great mart for mules and horses. Near this place is a well-wooded country called Gorosuava, abounding with fine limestone, where a considerable quantity of rich iron ore is found. How deplorable is it that the people should yet have to learn the application of such valuable resources!

The neighbourhood of Corritiva is watered by fine rivers, which flow into the Parana. Many of the streams produce gold, particularly the Rio Verde; and one called the Tibigi is rich in diamonds, as the few good families in its vicinity have reason to remember with gratitude. More to the westward it is dangerous to travel, since in that direction live the Anthropophagi, who were driven from these boundaries a few years ago. The country to the north is very full of wood.

The cattle at Corritiva sell at various prices; oxen, much fatter and in better condition than those of Rio de la Plata or of Rio Grande de St. Pedro, may be bought for about 12s. or 15s. a head. The horses are in general finer than those of Spanish America; mules for the pack-saddle sell at about 40s., and those for riding at from three to six pounds. There is, however, great fluctuation in the prices, owing to the occasional scarcity as well as the occasional abundance of money.

But to return from this digression to San Francisco. The chief occupations of the inhabitants are the cutting of timber, and other labours connected with ship-building. Vessels of large dimensions, and a number of small craft for coasters, have been built here by merchants of Rio de Janeiro, Bahia, and Pernambuco. When this trade is brisk, there is a great demand for the various classes of artisans whom it requires, and many negroes are employed. The wood used is so strong, and holds the iron so firmly, that ships built of it endure many years, and are in greater esteem with the Portuguese and Spaniards than those built in Europe. On this account, the harbour of San Francisco is likely to become of considerable value to Brazil; and as it is connected with Corritiva, the cattle of which have been found superior to Rio Grande, there is every probability that at no distant period the Portuguese navy will be here supplied with salt provisions. This must, however, depend on the completion of the great road over the mountains, to which the present administration have laudably directed their attention, with a degree of zeal commensurate to the importance of the work in a national point of view.

I must not omit noticing another production in this district, which will rise in utility and value as the port of St. Francisco improves. Toward the north there are woods of fine large pines, exceedingly hard, tough, and full of resin. They constitute a singular variety of the genus *Pinus*; the boughs branch off from the upper part of the tree only, and have tussocks of leaves at each extremity. A tree eighty feet high, for instance, will appear without branches to the height of about fifty-five feet, the branches there extend horizontally in every direction, with leaves at their extremities, the lowest and largest to a distance of fourteen or fifteen feet from the stem, and the higher ones gradually diminishing in length towards the top, which ends in a tuft of leaves as a crown for the whole. These trees are very picturesque, and indeed beautiful; they grow to a sufficient size to

serve as masts for ships of two or three hundred tons ; I was told there were much larger ones to be found.

Resuming our voyage, we left San Francisco, and, passing the port of Cananea, arrived near the entrance of the harbour of Santos. The coast along which we sailed is low and flat, and on its verge are some poor fishing-huts, which rather add to the dreariness of its appearance. It is covered with lofty trees, which also fringe the mountainous scenery beyond it. Several rivers occur, of little note in geography, but highly advantageous to the settlers, as they pass the very doors of the dwellings, and afford easy means for the transport of produce from the interior. On nearing Santos, we passed several bold rocks, called the Alcatrases, and a ledge or reef on which the sea broke furiously. The main land is very elevated and mountainous, so much so that the low grounds which extend from its base are scarcely perceptible from the heights next beyond them.

The harbour of Santos has a safe entrance, and is very secure ; it is a strait, having the island of St. Vincent to the left, for the extent of half a mile, when it takes a different direction. Here is situated the port, which has good anchorage, with regular soundings towards the shore, which shoals gradually. The currents and eddies cause some inconvenience, and the high land occasions much variation in the winds, which perplexes mariners on their entrance into the narrows, but as the water is not deep, and the current far from strong, a ship is safe the moment her anchor is let go, and by means of a boat and kedge she may be placed in any situation the pilot chooses. The part called the narrows is defended by two forts, on passing which there is a kind of lagoon of three or four leagues in length, almost full of mangroves, terminated by the town of Santos, one of the oldest European settlements in Brazil. In common with St. Paul's, it owes its origin to the first shipwreck on the island of St. Vincent. The river or lagoon has three or four fathoms water and a muddy bottom. Santos is a place of considerable trade, being the store-house of the great captaincy of St. Paul's, and the resort of many

vessels trading to the Rio de la Plata. It is tolerably well built, and its population, consisting chiefly of merchants, shop-keepers, and artificers, amounts to six or seven thousand souls. The situation is by no means healthy, as the country around it is low, woody, and frequently deluged with rain, by reason of the high mountains in its vicinity, which impede the passage of the clouds. Several rivulets flowing from the foot of these mountains intersect the land in various directions, and unite in one great river a little above the town of Santos. The rice of this district, which is grown in great quantities, is considered the best in Brazil, and the bananas are equally noted.

From this port the Spanish territories, as well as Rio Grande, receive a great proportion of their sugar, coffee, rum, rice, mandioca, indigo, &c.; in return they bring hides and tallow, which are generally exported hence to Europe. The Portugueze send much of their produce to the Spanish colonies, and are generally ill paid, but the shortness of the voyage, and the want of other markets, tempt many young men to speculate, notwithstanding the heavy duties and the numberless petty obstacles with which their neighbours have impeded and encumbered this commerce. A Spaniard in his own country rarely allows even a shadow of justice to a Portugueze; he uses a thousand artifices for procrastinating the decision of a cause at issue between them, till the latter, when his patience is completely exhausted, finds that he is likely to derive nothing from the contest but immense piles of law-papers, frequently written on the most trivial points in litigation, and paid for at an exorbitant price. If he persevere after all this disappointment, it generally happens that another alcalde or judge is appointed, and then the business is laid on the shelf. The injured Portugueze, after so much waste of time and money, is threatened with worse consequences, and frequently is obliged to leave the country in ruin and disgust.

As Santos is the embarking place of St. Paul's, its intercourse with that town is very considerable. In the course of a day several

hundred mules frequently arrive, loaded with the produce of the country, and return with salt, iron, copper, earthen wares, and European manufactures. For the traffic of its immediate vicinity, it has the convenience of water-carriage, its river being navigable about twenty miles, up to Cuberton, where an officer with a guard of soldiers is stationed to receive the King's duties for the repair of the roads and other public purposes.

The governor of Santos being subject, in all cases, to the governor of St. Paul's, we applied to him for permission to go thither, which was immediately granted. It was now eight in the evening, and we were without an asylum for the night. I had several letters of recommendation, not one of which procured us any civility, and we found that the inhabitants were far from being courteous to strangers. We were willing to impute this to want of convenient accommodations, but it may be generally observed, that along the whole coast the same shyness prevails, while in the interior the people vie with each other in acts of hospitality. Perhaps in all countries this duty is most practised where the occasions for its exercise most rarely occur.

Being unable to procure a bed at Santos, we were obliged to engage a canoe to convey us up the river to Cuberton, where we arrived at two in the morning, and were introduced into the guard-house for a lodging. The corporal being called up, accommodated us as well as he was able; we lay down on the softest planks we could find, and made pillows of our portmanteaus, but though much wearied we found ourselves little disposed to sleep on so uneasy a couch. At sunrise, when we got up, an extraordinary and busy scene presented itself; before the guard-house was a large space of ground enclosed by the storehouse and other outbuildings, and here above a hundred mules were led out to be harnessed and loaded; the gentleness and tractability of these fine large animals pleased us much, and the expertness of their masters, particularly of the negroes, in placing and replacing the burdens, was truly surprising.

From the good corporal, who was commanding-officer here, we received every attention, and much more civility than we had reason to expect from the experience we had of the unaccommodating disposition of the people in Santos, in much better circumstances than himself. He procured us a good breakfast, and furnished us with saddle mules for our journey, at the rate of ten shillings each, the distance being eight leagues. Having obtained a guide we mounted, and proceeded about half a mile, when we reached the foot of the stupendous mountains we had to cross. The road is good and well paved, but narrow, and on account of the rugged acclivities is cut in a zig-zag direction, with very frequent and abrupt turnings continually on the ascent. The trains of loaded mules which we met on their way to Santos rendered the passage disagreeable, and at times dangerous. In many places the road is cut through the solid rock for several feet, in others along the perpendicular sides, and it leads frequently over the tops of conical mountains, along the edge of precipices, down which the traveller is liable to be thrown into an impervious thicket full thirty yards below. These dangerous places are secured by parapets. After ascending for an hour and a half, during which time we made innumerable turnings, we arrived at a resting place, near which, at a spot a little lower than the road, we found water. This place, as our guide informed us, was only half-way to the summit; we were astonished at the intelligence, as the clouds were already so far below us that they obstructed our prospect. During our progress hither, we observed that the mules travel as quick on an ascent as on level ground; they much excel the horse in uneven roads with sharp turnings, and still more so in bad roads.

To attempt the geology of mountains so covered by vegetable matter would be a difficult task; the component parts of those along which we passed appeared to be granite, and frequently soft crumbling ferruginous sand-stone. Some picturesque streams bursting from their high sources form fine cascades, and in crossing

the road force their way through many detached and round masses of granite. The woods are so thick in every part, except where the mules tread, that no soil can be seen; the branches of the trees in some places meet and form an arbour over the road, which shades the traveller from the heat of the sun, and shelters him from rain.

After resting for about twenty minutes we again mounted and resumed our ascent. The road presented at times four or five zig-zags above us at one view, and gave us fresh reason for astonishment at the completion of a work so fraught with difficulties. The millions of crowns which must have been expended in clearing the woods and thickets in its course, and in cutting through the solid rock for a considerable distance, as well as in paving it through the whole extent of the ridge, afford no mean idea of the enterprising spirit of the Brazilians. Few public works, even in Europe, are superior to it; and if we consider that, as the district through which it passes, is but thinly inhabited, the labour bestowed on it must have been purchased most dearly, we shall hardly find one in any country so well completed under similar disadvantages.

In three hours we reached the summit, a plain of considerable extent, the lowest estimated height of which is six thousand feet. The surface is chiefly composed of quartz covered with sand. The sea, though distant twenty miles, seemed to us as if it washed the foot of the mountains; the level part of the coast and the port of Santos below us came not within the angle of vision. While we enjoyed this sublime prospect, we were refreshed by a cool breeze, which renewed our strength and spirits, and enabled us to pursue our journey with alacrity. Advancing about a mile and a half, we came to a part of the road which was cut several feet deep through the rock, and observed in this quarter many small streams which, though contiguous to the sea, all flow in a south-west course to an immense distance, and, uniting, form the great river Corrientes, which joins the

Plata. This circumstance will sufficiently explain the form of this mighty ridge of mountains, namely, that the highest and steepest side fronts the sea, and that the other shelves more gradually and with more frequent outlets to the plains of the interior. This part of the road is lined by fine trees and large thickets on both sides. The heavy rains of the season (December) had damaged it in various parts; the readiest mode of repairing these breaks is to cut down several trees, about seven inches diameter, place them across, and fasten them down with hooked stakes. The mules which travel these rugged declivities, though far more hardy than horses, frequently fall victims to fatigue; we observed some dead by the way-side. In the course of our route we passed several parties of negroes and some of Indians, working at repairs in the road, or making new branches from it. Some of them I noticed with swellings in the neck, though very different from those I have observed in Derbyshire and other mountainous countries. In the case of these Indians not only there appeared that protuberance from the glands commonly called a wen, but lumps of from half an inch to three inches in diameter hung from it in an almost botryoidal form.

After crossing several rivulets and passing a few houses, we arrived at a tolerable inn, belonging to an officer of militia, where we were soon provided with plenty of milk, coffee, and fowls. It is distant sixteen or twenty miles from St. Paul's, and may be considered as half-way between that town and Santos. The owner, who was much surprised to see Englishmen, treated us with every civility, and procured us a change of saddle-mules. While they were preparing, he shewed us a tract of land in front of his house, tolerably well-cleared, where we took an hour's shooting. We then proceeded through a much more open country, which bore the traces of former cultivation, and seemed of late to have been much neglected. As we drew nearer St. Paul's, the road improved, and was enlivened by a greater number of habitations in its vicinity.

We passed two convents, which had the air of convenient houses, and were distinguished by large crosses erected before them. The land was watered by several fine streams; in one part we observed a quarry of ferruginous grit-stone, but we had not leisure to make much mineralogical research. St. Paul's, although on an elevated site, is not observed at any great distance in this direction. In its immediate neighbourhood the river runs parallel to the road, which it sometimes partially overflows, and covers with sand. To our left we saw a large astallage, or inn, where numbers of mules are unloaded, and travellers commonly pass the night. It consists of a very large shed, supported upon upright pieces of timber, with separate divisions for receiving the cargoes or burdens of the mules, each traveller occupying as many as his goods require; and there is a piece of ground, of about a hundred yards in circumference, planted with small upright stakes at ten or fifteen feet distance, to which the bridles of the mules are tied while they are fed, saddled, and loaded. These astallages are common in all parts of Brazil.

On entering the town, although we had expected much from its being the capital of the district, and the residence of the governor, yet we were struck with the neat appearance of its houses, stuccoed in various colours; those in the principal streets were two or three stories high. Having arrived an hour or two before sun-set, we walked to the house of a gentleman, to whom we had a letter of recommendation, but he being absent, we were obliged to pass the night at the astallage, where our mules had been put up. It was a miserable abode. The next morning we breakfasted with our friend, and were conducted by him to the governor, Brigadier General Orte, who honoured us with an invitation to dinner, permitted a perishable cargo of my friend's property, which was lying at Santos, to be unloaded, and gave us a general welcome to his palace. We had the good fortune to

find that two of His Excellency's aides-de-camp, men of excellent character, had been educated in England. They assisted us in obtaining lodgings, rendered us every service that we stood in need of, and shewed an earnest desire to make our stay as agreeable as possible.

CHAP. V.

Description of St. Paul's. — System of Farming prevalent in its Neighbourhood. — Excursion to the Gold Mines of Jaragua: — Mode of working them. — Return to Santos.

ST. PAUL'S is situated on a pleasing eminence of about two miles in extent, surrounded on three sides by low meadow land, and washed at the base by rivulets, which almost insulate it in rainy weather; it is connected with the high-land by a narrow ridge. The rivulets flow into a pretty large stream called the Tieti, which runs within a mile of the town in a south-west direction. Over them there are several bridges, some of stone and others of wood, built by the late governor. The streets of St. Paul's, owing to its elevation (about 50 feet above the plain), and the water which almost surrounds it, are in general remarkably clean; the material with which they are paved, is lamillary grit-stone, cemented by oxide of iron, and containing large pebbles of rounded quartz, approximating to the conglomerate. This pavement is an alluvial formation containing gold, many particles of which metal are found in the chinks and hollows after heavy rains, and at such seasons are diligently sought for by the poorer sort of people.

This city was founded by the Jesuits, who were probably tempted by the gold mines in the vicinity, more than by the salubrity of its air, which however is not excelled by any on the whole continent of South America. The medium of the thermometer here is between 50 and 80 degrees; in a morning I have observed it at 48, and even lower, though I was not there in the winter months. The rains are by no means heavy or of long continuance, and the thunderstorms are far from being violent. The cold in the evenings was

frequently so considerable that I was obliged to shut my doors and windows, put on more clothes, and have a pan of embers in the room, there being no chimneys.

Here are several squares, and about thirteen places of religious worship, namely, two convents, three monasteries, and eight churches, the greater part of which, as well as of the whole town, is built of earth. The mode of erecting the walls is as follows: a frame is constructed of six moveable planks placed edge-wise, opposite each other, and secured in this position by cross-pieces bolted with moveable pins. Earth is put in by small quantities, which the workmen beat with rammers and occasionally moisten with water to give it consistency. Having filled the frame or trough, they remove it and continue the same operation till the whole shell of the house is completed, taking care to leave vacancies and put in the window-frames, door-frames, and beams as they proceed. The mass in course of time becomes indurated, the walls are pared perfectly smooth inside, and take any colour the owner chooses to give them; they are generally enriched with very ingenious devices. This species of structure is durable; I have seen some houses thus built that have lasted two hundred years, and most of them have several stories. The roofs are made to project two or three feet beyond the wall, in order to throw off the rain to a distance from the base; spouts might be a more effectual preservative against wet, but their use is little known here. They cover their houses with gutter-tiles, but though the country affords excellent clay and plenty of wood, very few bricks are burnt.

The population of this place amounts to full fifteen thousand souls: perhaps nearer twenty thousand; the clergy, including all ranks of religious orders, may be reckoned at five hundred. They are in general good members of society, free from that excessive bigotry and illiberality which is the reproach of the neighbouring colonies, and their example has so beneficial an effect on the rest of the inhabitants, that I may presume to say, no stranger will be mo-

lested while he acts as a gentleman, and does not insult the established religion. His Excellency the Bishop is a most worthy prelate, and were the inferior orders in his diocese to follow his steps in cultivating the sciences, and diffusing useful information, they would command greater respect from their flocks, and by that means further the interests of the religion they profess. Priests, so ignorant, can hardly escape contempt.

No endemial diseases at present prevail here. The small-pox formerly, and indeed of late, made great havoc among the inhabitants, but its progress has been checked by the introduction of vaccine inoculation. Professors attended at a large hall belonging to the governor, to which the public were invited, and the operation was performed gratis. It is to be hoped that the credit of this preventative will make its way among the people here, for they are not competent to enter into the merits of that controversy which injured it in Europe.

Here are few manufactures of any consequence; a little coarse cotton is spun by the hand, and woven into cloth, which serves for a variety of wearing apparel, sheets, &c. They make a beautiful kind of net-work for hammocks, which are fringed with lace, and form an elegant piece of furniture, being slung low, so as to answer the purpose of sofas. The ladies are particularly fond of using them, especially when the heat of the weather disposes them to ease and indolence. The making of lace is a general employment for females, some of whom excel in it. The shop-keepers here are a numerous class, who, as in most colonial towns, deal in almost every thing, and sometimes make great fortunes. Here are few doctors of medicine, but many apothecaries; some silver-smiths, whose articles are equally indifferent both in metal and workmanship; tailors and shoe-makers in great numbers; and joiners, who manufacture very beautiful wood, but are not so moderate in their charges as the former classes of tradesmen. In the out-skirts of the city live a number of Creolian Indians, who make earthen-ware for

culinary purposes, large water-jars, and a variety of other utensils ornamented with some taste. The greatest proportion of the inhabitants consists in farmers and inferior husbandmen, who cultivate small portions of land, on which they breed large stocks of pigs and poultry for sale. With these the market is generally well-supplied, and in the fruit-season is also stored with pines, grapes, peaches, guavas, bananas, a few apples, and an enormous quantity of quinces.

Esculent plants are grown in great profusion and variety. Here is a favourite bulbous root called the Cara, which is equal to the best potatoe, and even more farinaceous; it grows to about five inches in diameter, and affords excellent food either boiled or roasted. Here are fine cabbages, sallad-herbs, turnips, cauliflowers, artichokes, and potatoes; the latter, though very good, are little used; the sweet potatoe is in greater request among the natives. Maize, beans, green-peas, and every species of pulse flourish amazingly. Fowls are cheap; we bought some at three-pence and sixpence each; small pigs from one to two shillings, and fitches of bacon, cured after the mode of the country, at about two-pence per pound. Turkeys, geese, and ducks are abundant, and reasonable in price; the latter are of the Muscovy breed, enormously large, some weighing ten or fourteen pounds. Here is a singular breed of cocks; they resemble the common English in plumage and shape, but they crow very loud, and continue their last note for a minute or two. When their voice is good, they are much esteemed, and are sent for as curiosities from all parts of Brazil. The cattle are in general good, considering that so little attention is paid to feeding them; when their pastures are full of grass, they are tolerably fat, but when otherwise they become lean. A drove may be bought at 24s. or 30s. a head; beef at about a penny or three-halfpence per pound. The curriers have a singular method of blackening cow-hides and calf-skins: when they have prepared them for that operation, they search for some mud-hole at the bottom of a ferruginous stratum,

a ditch for instance ; with the mud they cover that side of the skin required to be stained ; and they prefer this material to the solution of copperas, probably with reason, as the sulphate of iron formed by the decomposed pyrites acts more mildly in this state than when applied in the common way.

The horses are very fine, and in general docile ; when well trained they make excellent chargers. Their size is from $12\frac{1}{2}$ to $14\frac{1}{2}$ hands, and they vary in price from three pounds to twelve. Mules, as we have before observed, are considered more useful beasts of burden. The breed of sheep is quite unattended to, and mutton is rarely or never eaten. Here is a very fine and large breed of goats, whose milk is generally used for domestic purposes. The dogs are very indifferent, and of no distinct race.

In my walks round the city, I had frequent opportunities of examining the singular succession of horizontal strata, that form the eminence on which it stands. They lie in the following order : — first, one of red vegetable earth of variable depth, impregnated with oxide of iron ; below that, sand and adventitious matter of different shades of colour, as ochre-red, brown, and dusky yellow, together with many rounded pebbles, which indicate it to be of rather recent formation ; it varies in depth from three to six feet, or perhaps to seven, and its lower part is uniformly yellow : under this is a bed of exceedingly fine clay of various colours, but for the most part purple ; the white and yellow is the purest in quality ; it is interveined with thin layers of sand in various directions. Then succeeds a stratum of alluvial matter, which is very ferruginous ; it rests on a half-decomposed substance, apparently migrating from a granite, in which the proportion of feld-spar exceeds that of the quartz and mica *. The whole is incumbent on compact granite. The

* Probably the colouring matter arises from decomposition of the mica ; I have frequently observed a mass of granite having its surface decomposed into a red clay, in which the particles of mica were hardly perceptible, while the compact rock below contained a very fair proportion of that substance.

sides of the mount are steep, and in some places nearly perpendicular*.

The fertility of the country around St. Paul's may be inferred from the quantities of produce, with which, as I have stated, its market is supplied. About a century ago, this tract abounded with gold; and it was not until they had exhausted it by washing, that the inhabitants thought of employing themselves in husbandry. As they did so more from necessity than from choice, they were tardy in pursuing those improvements which other nations have made in this noble art, and, pining at the disappearance of the precious mineral, considered their new occupation as vile and degrading. Indeed throughout the whole of Brazil, the husbandmen have ever been considered as forming a class greatly inferior in point of respectability to the miners; and this prejudice will in all likelihood subsist until the country shall have been drained of its gold and diamonds, when the people will be compelled to seek in agriculture a constant and inexhaustible source of wealth.

I shall attempt to describe the system of farming which at present prevails in the neighbourhood of St. Paul's. It has been elsewhere observed that, in this extensive empire, land is granted in large tracts, on proper application; and we may naturally suppose that the value of these tracts depends more or less on their situation. It therefore becomes the first object of a cultivator, to look out for unoccupied lands as near as possible to a large town; good roads and navigable rivers are the desiderata next in point of consequence which he attends to. When he has made choice of a situation, he applies to the governor of the district, who orders the proper officers to mark out the extent required, generally a league or a league and a half square, sometimes more. The cultivator then purchases as many negroes as he can, and commences his operations by erecting habi-

* In one part of the town is found a beautiful species of decomposed granite, consisting of extremely white feld-spar, quartz, and very little mica.

tations for them and himself, which are generally miserable sheds, supported by four posts, and commonly called ranchos. His negroes are then directed to cut down the trees and brushwood growing on the land, to such an extent as he thinks they will be able to manage. This done, they set fire to all they have cut, as it lies on the ground. Much of the success of his harvest depends on this burning; if the whole be reduced to ashes he expects a great crop; if, through wet weather, the felled trees remain only half burnt, he prognosticates a bad one. When the ground is cleared, the negroes dibble it with their hoes, and sow their maize, beans, or other pulse; during the operation they cut down any thing very much in the way, but never think of working the soil. After sowing as much seed as is thought requisite, they prepare other ground for planting cassada, here called mandioca, the root of which is generally eaten as bread by all ranks in Brazil. The soil * for this purpose is rather better prepared; it is raked up in little round hillocks, not unlike mole-hills, about four feet asunder; into which are stuck cuttings from branches of the plant, about an inch thick and six or eight long; these soon take root, and put forth leaves, shoots, and buds. When enough has been planted for the entire consumption of the farm, the owner, if he is rich enough, prepares means for growing and manufacturing sugar. He first employs a carpenter to cut wood, and build a mill with wooden rollers for crushing the canes, by means of water if a stream is at hand, if not, by the help of mules. While some of the negroes are assisting the carpenter, others are employed in preparing ground in the same way as for mandioca. Pieces of cane containing three or four joints, and in length about six inches, cut from the growing stem, are laid in the earth nearly horizontally, and are covered with soil to the depth of about four inches. They shoot up rapidly, and in three months have a bushy appearance not unlike flags; in twelve or fifteen

* Mandioca requires a dry hot soil, of a sandy nature.

months more they are ready for cutting. In rich virgin soil it is not uncommon to see canes twelve feet high and astonishingly thick.

The Indian corn and pulse are in general ripe in four months or eighteen weeks. The average return is two hundred for one; it is a bad harvest when it falls short of one hundred and fifty.

The mandioca is rarely ready to take up in less than eighteen or twenty months; if the land be suitable, it then produces from six to twelve pound weight per plant*. They grow very little indigo in this neighbourhood, and what they have is of indifferent quality. Their pumpkins are of enormous size, and sometimes are served up as table-vegetables, but more frequently given as food to the horses. Melons here are scarcely palatable.

In no branch of husbandry are the farmers so defective as in the management of cattle. No artificial grasses are cultivated, no enclosures are made, nor is any fodder laid up against the season of scarcity. The cows are never milked regularly; they seem to be considered rather as an incumbrance to a farm than a valuable part of the stock. They constantly require salt, which is given them once in fifteen or twenty days, in small proportions. Their dairies, if such they may be called, are managed in so slovenly a manner, that the little butter that is made becomes rancid in a few days, and the cheese is good for nothing. In this essential department they are deplorably deficient; rarely indeed is there to be seen a farm with one convenience belonging to it. For want of proper

* This generous root requires but little preparation to make it serve as a substitute for bread. When taken out of the ground they wash and scrape it clean, and then rasp it on a coarse grater of iron or copper, press the juice from it, and place it on a hot surface, a shallow copper-pan for instance, four or five feet in diameter, or a clay one, with a brisk fire underneath; while drying it is constantly stirred, and when the moisture is completely evaporated, it is immediately fit for use. If preserved from wet, it will keep good a long time. In broths and soups it becomes gelatinous, and affords rich nourishment; it is particularly good when eaten with cheese. The wild or spurious mandioca, called Ipé, is little inferior, when roasted, to fine chesnuts. The Portugueze introduce it at table, boiled as well as roasted.

places in which to store their produce, they are obliged to lay it in promiscuous heaps ; and it is not uncommon to see coffee, cotton, maize, and beans, thrown into the corners of a damp shed, and covered with a green hide. One half is invariably spoiled by mould and putridity, and the remainder is much deteriorated, through this idle and stupid negligence.

They feed their pigs on Indian corn in a crude state ; the time for confining them to fatten is at eight or ten months old ; and the quantity consumed for the purpose is eight or ten Winchester bushels each. When killed, the lean is cut off the sides as clean as possible, the fat is cured with very little salt, and in a few days is ready for market. The ribs, chine-bone, and lean parts are dried for home consumption.

The farm-houses are miserable hovels of one story, the floor neither paved nor boarded, and the walls and partitions formed of wicker-work plastered with mud, and never under-drawn. For an idea of the kitchen, which ought to be the cleanest and most comfortable part of the dwelling, the reader may figure to himself a filthy room with an uneven muddy floor, interspersed with pools of slop-water, and in different parts fire-places formed by three round stones to hold the earthen pots that are used for boiling meat ; as green wood is the chief fuel, the place is almost always filled with smoke, which, finding no chimney, vents itself through the doors and other apertures, and leaves all within as black as soot. I regret to say that the kitchens of many opulent people are in not much better condition.

It may well be imagined that in a country like this, a stranger finds the greatest comfort and enjoyment out of doors. The gardens in St. Paul's, and its vicinity, are laid out with great taste, and many of them with curious elegance. The jasmine is every where a favourite tree, and in this fine climate bears flowers perennially, as does the rose. Carnations, pinks, passion-flowers, cocks-combs, &c. grow in great plenty ; one of their most estimable shrubs is the

Palma Christi, which gives fruit the first year, and yields abundance of castor-oil, which all families possess in such quantity, that no other sort is burnt.

Bees are by no means uncommon ; they are easily domesticated, and, I believe, are perfectly harmless. Their honey is pleasant ; the wax, particularly that generally sold, which is taken from their nests in old forest-trees, is very foul, but might be purified by a very simple process. The woods contain a great variety of animals of the monkey kind, and also beasts of prey, some of which have tolerably good fur. Among these may be classed a peculiar species of the otter. Insects are numerous, but the mosquitos are not so offensively so as in the Rio de la Plata. The animalculum, called the niagua or jigger, is troublesome ; it beds itself under the nails of the toes, and sometimes of the fingers, but it may easily be banished by extracting it and its bag of eggs with a needle, and filling the cavity with calomel or snuff, for fear any should have remained. Reptiles, I was told, were very numerous, but I saw few, except toads, which in the evenings crawl upon the foot paths, and even infest the streets of the city. The sorococo or jararraca (serpents) are said to be very dangerous.

The woods produce large and durable timber, well calculated for building. Of their trees, all of which retain their Indian names, some yield very fine gums. The jacarandá, called in England rose-wood, is here very common. Many of their shrubs bear beautiful flowers, and are very aromatic. Among the innumerable creeping plants which clothe the soil of their uncleared lands, there are some distinguished as infallible antidotes to the bite of venomous reptiles ; one in particular, called the corazão de Jesu *, is universally esteemed.

Beyond the plain which nearly encircles St. Paul's, the country is hilly, or rather mountainous. Had the period of my stay been

* Its leaf is shaped like a heart.

longer, I should have devoted some time to a geological tour in that district; but having urgent reasons to hasten my departure for Rio de Janeiro, I had leisure to take only one excursion of this kind. The governor invited me to visit the old gold-mines of Jaragua, the first discovered in Brazil, which were now his property, together with a farm in their vicinity, distant about twenty-four miles from the city. We travelled along a tolerable, and in some places, fine road, in a southerly direction, for twelve miles, and crossed the Tieti. This river is here considerably larger and deeper than in the neighbourhood of St. Paul's; it has an excellent wooden bridge, free from toll. On its banks there are some situations truly enviable; fine rich virgin lands covered with timber, and capable of producing, not only the necessaries, but the luxuries of life, in a hundredfold degree, if properly cultivated. It was melancholy to behold a territory, which, for its teeming soil and genial climate, deserves to be called a paradise, neglected and solitary like that of Eden after the fall; while its infatuated possessors, like the offspring of Cain, hungering for gold, kept aloof from the rich feast which nature here spread before them.

After travelling onward four leagues, we arrived at the ancient mines of Jaragua, famed for the immense treasures they produced nearly two centuries ago, when at the ports of Santos and St. Vincent, whence the gold was shipped for Europe, this district was regarded as the Peru of Brazil. The face of the country is uneven and rather mountainous. The rock, where it is exposed, appears to be primitive granite, inclining to gneiss, with a portion of hornblende, and frequently mica. The soil is red, and remarkably ferruginous, in many places apparently of great depth. The gold lies, for the most part, in a stratum of rounded pebbles and gravel, called *cascalhão*, immediately incumbent on the solid rock. In the valleys, where there is water, occur frequent excavations, made by the gold-washers, to a considerable extent, some of them fifty or a hundred feet wide, and eighteen or twenty deep. On many of the

hills, where water can be collected for washing, particles of gold are found in the soil, little deeper than the roots of the grass.

The mode of working these mines, more fitly to be denominated washings, is simple, and may be easily explained :

Suppose a loose gravel-like stratum of rounded quartzose pebbles and adventitious matter, incumbent on granite, and covered by earthy matter of variable thickness. Where water of sufficiently high level can be commanded, the ground is cut in steps, each twenty or thirty feet wide, two or three broad, and about one deep. Near the bottom a trench is cut to the depth of two or three feet. On each step, stand six or eight negroes, who, as the water flows gently from above, keep the earth continually in motion with shovels, until the whole is reduced to liquid mud and washed below. The particles of gold contained in this earth descend to the trench, where, by reason of their specific gravity, they quickly precipitate. Workmen are continually employed at the trench to remove the stones, and clear away the surface, which operation is much assisted by the current of water which falls into it. After five days' washing, the precipitation in the trench is carried to some convenient stream, to undergo a second clearance. For this purpose wooden bowls are provided, of a funnel shape, about two feet wide at the mouth, and five or six inches deep, called *gamellas*. Each workman standing in the stream, takes into his bowl five or six pounds weight of the sediment, which generally consists of heavy matter, such as oxide of iron, pyrites, ferruginous quartz, &c. of a dark carbonaceous hue. They admit certain quantities of water into the bowls, which they move about so dexterously, that the precious metal, separating from the inferior and lighter substances, settles to the bottom and sides of the vessel. They then rinse their bowls in a larger vessel of clean water, leaving the gold in it; and begin again. The washing of each bowlful occupies from five to eight or nine minutes; the gold produced is extremely variable in quantity, and in the size of its particles, some of which are so

Drawn by Alonzo from a sketch by W. Howe.

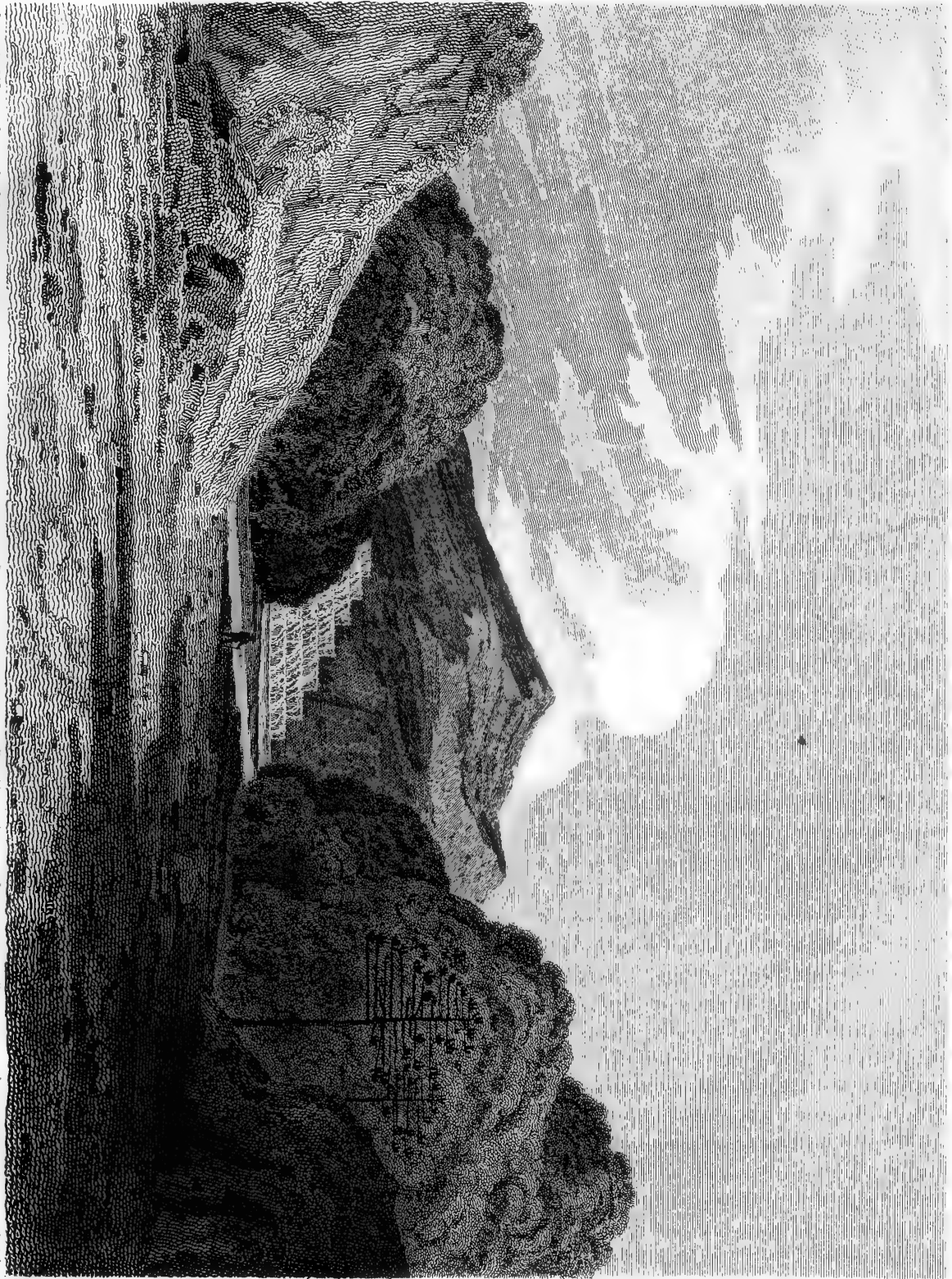

Borringers Sculp.

(View of the Gold Washing at Panapa near Mount Pauls.)



minute, that they float, while others are found as large as peas, and not unfrequently much larger. This operation is superintended by overseers, as the result is of considerable importance. When the whole is finished, the gold is borne home to be dried, and at a convenient time is taken to the permutation office, where it is weighed, and a fifth is reserved for the Prince. The remainder is smelted by fusion with muriate of mercury, cast into ingots, assayed, and stamped according to its intrinsic value, a certificate of which is given with it; after a copy of that instrument has been duly entered at the mint-office, the ingots circulate as specie.

My attention was strongly engaged by the immense debris or refuse of old washings, which lay in numberless heaps, and contained various substances that gave me strong hope of finding some interesting and valuable specimens of tourmalines, topazes, and other crystallizations, and also a rich series of rocks, which might form the geognostics of the country. So strongly was I prepossessed with this hope, that I really fancied I had within my reach some of the finest mineral products of Brazil. Early one morning, before the sun became too hot for work, I set out accompanied by two or three men, with iron crows and hammers, whom I had engaged to assist me. We broke up immense quantities of quartzose and granite-like matter in various stages of decomposition, and others of a ferruginous kind, but after pursuing the operation for three whole days, until my hands could no longer wield the hammer, I was obliged to give up the search as fruitless; not a grain of gold did I find, nor any thing of the nature of crystallization, except some miserable quartz, a little cubic and octaëdral pyrites, and some very poor manganese! In short the substances presented so little novelty, and were in themselves so ordinary, that I hesitated whether I should carry them with me to St. Paul's. This disappointment at the first gold mines I had seen, not a little dejected me.

In company with the Governor and his lady, I now took a survey of the farm; we walked and rode through extensive plantations,

the productions of which, as well as the mode of culture pursued, were similar to those I have already described. Our next recreation was hunting the deer. Let not the reader imagine that I am going to lead him a chase through miles of country with a pack of hounds and a joyous company of horsemen; the mode of hunting in Brazil affords no such diversion. Three or four men go out armed with guns and attended by two or three dogs; the men separate and wait in some open place; meanwhile the dogs quest among the plantations and thickets; if they find, they drive the game out, which the hunters immediately shoot. The deer are small, and of the fallow kind; but their flesh is not esteemed.

The wild animals of this district are chiefly monkeys, sloths, a variety of the porcupine, and opossums. These, and other predatory beasts, make great havoc among the poultry. Of the feathered tribe there are not many varieties; I shot several becassinias and beautiful lapwings* with red horns on each pinion, about half an inch in length. Here are great numbers of parrots and parroquets.

The vampire-bat, so often described by travellers, is a most formidable foe to the horses and mules. If he gets access to them in the night, he fixes on the neck-vein, above the shoulder, and sucks it to such a degree as to leave the animal almost covered with blood, fanning with his wings all the while he retains his hold, in order (as it should seem) to lull the pain caused by his bite.

The garden has a bed of fine potatoes, which were planted three or four years ago by Mr. Quarten, from Gibraltar. They are suffered to grow and reproduce themselves from season to season, none being taken up unless when wanted for food. Cabbages and other vegetables for the table grow in abundance.

* In the Spanish territories they are called *disperteros* (awakeners), on account of the noise they make when disturbed in the night. A flock of them in any plantation answers the purpose of an alarm-bell against thieves.

This farm has the advantage of very fine timber in its neighbourhood, and when the improvements, begun by the governor, are completed, it will be well provided with water, brought from a distance of six miles, in sufficient quantities to wash the hills, and to work the machinery of a sugar-mill. On the estate were employed about fifty negroes, and half that number of free Indians; the latter ate at their master's expence, and earned about sixpence a day; but they appeared far less laborious and handy than the negroes. They were clearing grounds and making walks in a wood, which when finished will render the place a most agreeable summer-retreat.

Among the many marks of kindness with which the governor honoured me, I must not omit his repeated assurances, that in the event of war between our respective countries, which was then talked of, he would not detain me. After remaining here five days, which were rendered as agreeable as possible by the polite civilities of my host, we set out on our return in the order in which we came: the governor and his lady in a carriage drawn by four mules, his aide-de-camp and myself on horseback, and six dragoons in front, the guard always allowed to an officer of his rank. We arrived at St. Paul's without any material occurrence.

This city is seldom visited by foreigners. The passes to it from the coast are so singularly situated, that it is almost impossible to avoid the guards who are stationed in them, to inspect all travellers and merchandize passing into the interior. Soldiers of the lowest rank on these stations have a right to examine all strangers who present themselves, and to detain them and their property, unless they can produce passports. I and my friends in our way hither were thrice obliged to exhibit our licence from the governor of Santos, which was attested. Our appearance at St. Paul's excited considerable curiosity among all descriptions of people, who seemed by their manner never to have seen Englishmen before; the very children testified their astonishment, some by running away, others by counting our fingers, and exclaiming, that we had the same number

as they. Many of the good citizens invited us to their houses, and sent for their friends to come and look at us. As the dwelling we occupied was very large, we were frequently entertained by crowds of young persons of both sexes, who came to the door to see how we ate and drank. It was gratifying to us to perceive that this general wonder subsided into a more social feeling; we met with civil treatment every where, and were frequently invited to dine with the inhabitants. At the public parties and balls of the governor we found both novelty and pleasure; novelty at being much more liberally received than we were in the Spanish settlements, and pleasure at being in much more refined and polished company.

The dress of the ladies abroad, and especially at church, consists of a garment of black silk, with a long veil of the same material, trimmed with broad lace; in the cooler season black cassimere or baize. In the same veil they almost always appear in the streets, though it has been partially superseded by a long coat of coarse woollen, edged with velvet, gold lace, fustian, or plush, according to the rank of the wearer. This coat is used as a general sort of undress, at home, in their evening walks, and on a journey, and the ladies, whenever they wear it, appear in round hats. The appellation of Paulista is considered by all the females here as a great honour; the Paulistas being celebrated throughout all Brazil for their attractions, and their dignity of character. At table they are extremely abstemious; their favourite amusement is dancing, in which they display much vivacity and grace. At balls and other public festivals they generally appear in elegant white dresses, with a profusion of gold chains about their necks, their hair tastefully disposed and fastened with combs. Their conversation, at all times sprightly, seems to derive additional life from music. Indeed the whole range of their education appears to be confined to superficial accomplishments; they trouble themselves very little with domestic concerns, confiding whatever relates to the inferior departments of the household to the negro or negra cook, and leaving all other matters

to the management of servants. Owing to this indifference, they are total strangers to the advantages of that order, neatness, and propriety, which reign in an English family; their time at home is mostly occupied in sewing, embroidery, and lace-making. Another circumstance repugnant to delicacy is, that they have no mantua-makers of their own sex; all articles of female dress here are made by tailors. An almost universal debility prevails among them, which is partly attributable to their abstemious living, but chiefly to want of exercise, and to the frequent warm-bathings in which they indulge. They are extremely attentive to every means of improving the delicacy of their persons, perhaps to the injury of their health.

The men in general, especially those of the higher rank, officers, and others, dress superbly; in company they are very polite and attentive, and shew every disposition to oblige; they are great talkers and prone to conviviality. The lower ranks, compared with those of other colonial towns, are in a very advanced state of civilization. It were to be wished that some reform were instituted in their system of education; the children of slaves are brought up during their early days with those of their masters; they are play-mates and companions, and thus a familiar equality is established between them, which has to be forcibly abolished when they arrive at that age, at which one must command and live at his ease, while the other must labour and obey. It has been said, that by thus attaching the slave to his master, in early youth, they ensure his future fidelity, but the custom seems fraught with many disadvantages, and ought at least to be so modified as to render the yoke of bondage less galling by the recollection of former liberty.

The religious processions here are very splendid, grand, and solemn; they have a striking effect, by reason of the profound veneration and enthusiastic zeal manifested by the populace. On particular occasions of this kind all the inhabitants of the city attend, and the throng is frequently increased by numbers of the neigh-

houring peasantry for several leagues round. The balconies of those houses, which command the best views of the spectacle, are crowded with ladies in their gala dresses, who consider the day as a kind of festival; the evening is generally concluded by tea and card-parties or dances.

We found very little difficulty in accommodating ourselves to the general mode of living at St. Paul's. The bread is pretty good, and the butter tolerable, but rarely used except with coffee for breakfast, or tea in the evening. A more common breakfast is a very pleasant sort of beans, called feijones, boiled or mixed with mandioca. Dinner, which is usually served up at noon or before, commonly consists of a quantity of greens boiled with a little fat pork or beef, a root of the potatoe kind, and a stewed fowl, with excellent sallad, to which succeeds a great variety of delicious conserves and sweet-meats. Very little wine is taken at meals; the usual beverage is water. On public occasions, or when a feast is given to a large party, the table is most sumptuously spread; from thirty to fifty dishes are served up at once, by which arrangement a succession of courses is obviated. Wine circulates copiously, and toasts are given during the repast, which usually occupies two or three hours, and is succeeded by sweet-meats, the pride of their tables; after coffee the company pass the evening in dancing, music, or cards.

I may here observe, that neither in St. Paul's nor in any other place which I visited, did I witness any instance of that levity in the females of Brazil, which some writers alledge to be the leading trait in their character. I allude to the custom which has been said to prevail among them, of throwing flowers from the balconies on such of the passers-by as they take a fancy to, or of presenting a flower or a nosegay to their favourites, as a mark of partiality. The circumstance which seems to have given rise to such an ill-founded conjecture is this: flowers are here considered an indispensable part of the female head-dress, and when a stranger is introduced to a lady, it is nothing more than an act of common courtesy for

her to take one from her hair to present to him. This elegant compliment he is expected to return in the course of the visit, by selecting a flower from the profuse variety which adorn the garden, or the balcony, and presenting it to her.

One singular custom I must not omit to notice, that of throwing artificial fruit, such as lemons or oranges, made very delicately of wax and filled with perfumed water. On the two first days of Lent, which are here celebrated with great festivity, persons of both sexes amuse themselves by throwing these balls at each other; the lady generally begins the game, the gentleman returns it with such spirit that it seldom ceases until several dozens are thrown, and both parties are as wet as if they had been drawn through a river. Sometimes a lady will dexterously drop one into the bosom of a gentleman, which will infallibly oblige him to change his linen, as it usually contains three or four ounces of cold water. On these days of carnival the inhabitants parade the streets in masks, and the diversion of throwing fruit is practised by persons of all ages. It is reckoned improper for men to throw at each other. The manufacture of these missiles, at such periods, affords no inconsiderable occupation to certain classes of the inhabitants; I have been informed that in the capital of Brazil many hundreds of people derive a temporary subsistence from the sale of them. The practice (as I can testify) is very annoying to strangers, and not unfrequently engenders quarrels which terminate seriously.

During our stay here an unpleasant report was circulated, that the port of Lisbon was shut against the English, and that war was daily expected to be declared between the two powers. Had it not been for the kindness of the governor in offering to permit our departure before he should receive orders to the contrary, we should have felt ourselves in a very disagreeable predicament. But news soon arrived that His Royal Highness the Prince Regent had left Portugal with all the court, and that they were embarked for the

Brazils, under the escort of a British squadron, dispatched by Sir Sidney Smith. This intelligence was most joyfully received by the Brazilians; they considered, indeed, that the occupation of Portugal by the French was a disaster very likely to ensue, but they consoled themselves with the hope of receiving a Prince, in whose praise every tongue was eloquent, and to whose cause every heart was loyal. The Brazilian empire was considered as established; and the worthy bishop consecrated the auspicious era by ordaining daily prayers in the cathedral, to invoke from Divine Providence the safe arrival of the Royal Family. News of their having touched at Bahia arrived in about ten days, and was welcomed by every demonstration of public joy, processions, fire-works, &c. Hoping every day to hear of their arrival at Rio de Janeiro, I made all ready for my departure, and devoted the few remaining days to a second excursion to the gold-mines, and to some farewell visits among my friends in the vicinity of St. Paul's. The governor and many of the principal inhabitants gave us parting invitations, and by their urbanity rendered the last hours we passed with them at once delightful and melancholy. Some of the latter accompanied us two leagues on our way, and on separating testified the warmest wishes for our welfare.

I never recall to mind the civilities I received at this city without the most grateful emotions, in which those will best sympathize who have known what it is to visit a remote city in a strange country, where, according to the narratives of preceding travellers, nothing prevailed but barbarism and inhospitality, and where they have been agreeably undeceived. It may easily be supposed that I found it difficult to reconcile the character of the Paulistas, such as I beheld it, with the strange accounts of their spurious origin, quoted by modern geographers. These accounts, founded on the suspicious testimony of the jesuits of Paraguay, and at variance with the best Portuguese historians, have been of late most ably confuted by an

enlightened member of the Royal Academy of Sciences at Lisbon*. He fully exposes the inconsistencies of *Vaissette* and *Charlevoix*, in ascribing the origin of St. Paul's to a band of refugees, composed of Spaniards, Portuguese, Mestizos, Mulattos and others, who fled hither from various parts of Brazil, and established a free-booting republic; and he satisfactorily shews that the first settlers were Indians of Piratininga and Jesuits, and that the city from its first foundation never acknowledged any other sovereignty than that of Portugal. The veracity of this account is further supported by the predominant character of the Paulistas, who, far from inheriting the obloquy which an ancestry of rogues and vagabonds would have entailed upon them, have long been famed throughout all Brazil for their probity, their industry, and the mildness of their manners †.

* Fr. Gaspar da Madre de Deos.

† I may also add their public spirit in resenting injuries done to individuals, and in supporting the cause of the oppressed; a singular instance of which I have often heard related. Some seventy years ago one of their governors, who was a nobleman, had an intrigue with the daughter of a mechanic. The whole town espoused the cause of the injured female, and compelled the governor, at the peril of his life, to marry her.

CHAP. VI.

Coasting Voyage from Santos to Zapitiva, and Journey thence to Rio de Janeiro.

WE left St. Paul's at ten in the morning, and took the same road to Santos by which we had come, there being no other, fit to travel. On the following day, before noon, we arrived at Cuberton, where we were detained by rain, until four in the afternoon. About seven we arrived at Santos, and as we were provided with a letter of introduction to a judge, and another to a merchant, we relied on a kinder welcome than we had met with on our first visit, the more so as we came from St. Paul's. We were, however, deceived. The judge received us coldly, and when I asked him where the person lived to whom our other letter was addressed, he seemed quite rejoiced at the opportunity for shewing us out of his house. The merchant was as frigid as the judge, and made us a paltry excuse. We then repaired to an apothecary, from whom we had experienced some acts of attention, and who had attended one of our friends, who, having left St. Paul's in a bad state of health, had waited here three weeks for a passage to Rio de Janeiro. After telling him our situation, and stating that the wet weather prevented us from passing the night in our canoe, he kindly offered us his shop-floor for a lodging, it being the only place under cover he had to spare. We commissioned him to offer four dollars to any of his neighbours who would admit us for the night, but he said it would be of no avail, as the people of Santos were proverbially notorious for their want of hospitality. The great influx of strangers and renegadoes from all nations into this and other towns on the coast, had completely steeled the hearts of the people against those claims on their good-

will, which the inhabitants of the interior, less frequently imposed upon, are ever ready to acknowledge and to satisfy.

Thus disappointed, we resolved not to wait at Santos for a ship, but to proceed to Rio de Janeiro, along the coast, in a canoe. Having hired one we embarked, and after rowing all night in a strait between the continent and the island of St. Omar, which forms one of the passages to Santos from sea, we arrived by sun-rise at Bertioga, situated at the north end of that island. It is a village, consisting of some tolerably good buildings, erected for the convenience of the Captain Mor and his attendants, who superintend a fishing establishment here, similar to that near St. Catherine's, and belonging to the same company, but very much inferior in point of extent and capacity. At both places the most expert of the negroes are employed in dressing whalebone, which is a considerable article of commerce, though smaller and less valuable than that of the Greenland whale. Along the coast which we passed, are several fine bays, where, in the best times of the fishery, large quantities of whales were annually caught. The buildings for boiling the blubber and storing the oil were conveniently situated

The fine harbour of Bertioga is well sheltered from all winds, and the town itself, being situated at the foot of a hill, is protected from the inclemencies of the weather, and is at times inconveniently warm. The basis of the hill is primitive granite, composed of hornblende, feld-spar, quartz, and mica. Fine springs of water, bursting from various parts, give variety to the scenery, and an agreeable freshness to the air. Though the place bore the appearance of poverty, we observed no signs of want; the sea affords great plenty and variety of eatable fish, and the soil produces pulse, of various sorts, and rice, quantities of which we saw loading in boats for Santos. The people with whom we had to treat used us civilly, and seemed anxious to anticipate and to gratify all our requests. As the Captain Mor was ill, he could not render us any assistance in procuring

a passage for St. Sebastian ; we were therefore obliged to hire the canoe to go forward.

A strong current setting in-shore detained us until midnight ; we then took advantage of a calm which succeeded, and rowed away for a headland to the eastward, near which we arrived about sun-rise, after a most laborious passage. The shore was quite solitary, with the exception of two very miserable huts, at which we could procure no better a breakfast than muscles. The face of the country is low and sandy, covered with underwood and groups of trees, and watered by rivulets from a range of mountains apparently about two leagues distant.

A breeze springing up about mid-day, we again embarked, but after contending with both elements for four hours, we were obliged again to take to our oars, in order to reach Porto Unya before sunset, which, with considerable exertion, we effected. At this place we observed a large plantation, belonging to a religious society at Santos, who hence derive a great part of their maintenance. After waiting till two in the morning for a change either of wind or current, we got out of port and proceeded on our voyage to Rio de Janeiro. We rowed against the wind till day-light, and then found ourselves near a bluff headland with steep rocks, forming a good harbour for boats, called Toque Toque, where we arrived about nine o'clock, having passed several conical islands, which are not laid down in any chart that I have hitherto seen. Off the point of Toque Toque, extends the fine island of St. Sebastian ; the strait between it and the main affords an excellent passage, and a good harbour for ships of war.

The wind still blowing fresh against us, we rested awhile, and were amused by watching some fishermen haul their nets ashore with large draughts of cavelhos in them. These fish weigh from fifteen to twenty pounds each, and are caught in great numbers along this coast.

Passing point Toque Toque at noon, we entered the strait of St. Sebastian. Its width is about three leagues, the land on both sides is bold and steep, and being well cultivated has a very grand and rich appearance. The varied foliage of the trees, and the different shades of verdure in the enclosures, combined with the romantic situations of the houses dispersed among them, presented a view worthy the ablest pencil; we had full leisure to enjoy it, for the wind being still adverse, our progress depended on the toil of our wearied boatmen. Several vessels, going the contrary way, passed us at full sail, the crews of which added to our chagrin by ironically wishing us a pleasant voyage. At four in the afternoon we arrived at the town of St. Sebastian, situated on a low tract of ground about three hundred yards from the beach. The inhabitants, amounting to two or three thousand, are an indigent and not very industrious people; they subsist chiefly on fish, which was the only food we could procure during the three days we staid among them. There are some inconsiderable plantations in the neighbourhood, where a little indigo is made, and some tolerably good tobacco is grown. This town is noted (and formerly was much more so) for its very large canoes scooped out of the solid timber; some of them I have seen of almost incredible dimensions. The civil government is entrusted to a Captain Mor, whose authority is supported by a garrison of ten or fifteen soldiers under the command of an ensign. At the house of the latter we took up our abode, while waiting for an opportunity to hire a large canoe to carry us to Zapitiva, near Rio de Janeiro. The people with whom we had to bargain, used every petty means to thwart and impose upon us, and our host shewed no disposition to protect us against their chicanery, so that we encountered many vexatious delays ere we could accomplish our purpose.

This place is by no means a desirable, or indeed, a tolerable residence for a stranger; it is exposed to all the inconveniences peculiar to low and sandy situations; the hot unwholesome weather, sel-

dom refreshed by a breeze, tends to multiply the immense swarms of mosquitos, which constitute one of the plagues of the Torrid Zone. The neighbouring island, on the contrary, being more elevated, has the advantage of a freer air, and is therefore less annoyed by these troublesome insects. It has the reputation of producing the best sugar, rum, and pulse, as well as the finest cattle in all Brazil, and these advantages, joined to its convenient situation, must render a plantation upon it highly valuable. In common with the opposite shore, and the rocks observable in various parts of the straits, it appears to be composed of the same primitive granite I have before described. Near the town of St. Sebastian's, I found some large pieces of basalt, which, when struck, emitted a very clear sound; I saw also some fragments of lime-stone, but these probably were part of some vessel's ballast, which had been thrown overboard in the bay, and washed ashore.

Having at length hired a canoe, we embarked for a village about five miles distant, called Bayro, where we arrived safe, and staid all night at the house of a fisherman, who undertook the charge of our navigation until we should arrive at Zapitiva. Bayro is a pretty but poor village, built near the beach, and is chiefly noted as being the place where most of the earthen-ware used at Rio de Janeiro is made. The clay for this purpose appears to be a decomposition of feld-spar. Here is a large convent, well built, and finely situated.

About nine in the morning, we embarked in our canoe, which was forty feet long, covered with an awning, and rowed by six men. In the afternoon we arrived at Porcos, a fine, bold, conical island, with good anchorage, but no port. Its coasts abound with excellent fish. Here was stationed a guard of soldiers to prevent contraband trade, and to give information respecting it; the officer, an ensign, made us welcome to all he had, and treated us with great kindness during our short stay. Leaving this place at two in the morning, we rowed through an archipelago of islets, and arrived at Porto

Negro, within four leagues of Isle Grande, and the morning following reached a bay in that island. The land is in general very high and irregular; in the interior it is well wooded, and contains some excellent iron ore which is very little known. Its coasts are but partially inhabited. The strait which separates it from the main land is an excellent harbour in all its extent, and was the rendezvous of some English privateers during our war with Spain. The country in its vicinity is well clothed with large timber, and appears very fruitful, but is thinly peopled by a set of men, whose manners and pursuits denote them to be outcasts from society. In the evening we entered a fine bay, and procured some refreshment at a house on the beach, where we intended to pass the night, but a plan had been laid to rob us, and we were obliged, on discovering it, to re-imbark before day-break, much rejoiced at having narrowly escaped the loss of our property and our lives. Pursuing our course among the many islands, with which this part of the coast is studded, we passed the beautiful and fertile island of Madeira, and, at noon, crossed two wide bays. A favourable breeze now, for the first time, sprung up, which lasted until we arrived at Zapitiva, and here ended our romantic canoe-voyage.

I would strongly recommend to every traveller, pursuing a similar course, the expediency of providing himself with a soldier commissioned to attend him, and to protect his person and property against the evil-minded persons, who prowl about the coast in search of plunder, and greedily seek every opportunity of securing, by fraud or force, the property of defenceless passengers. We had more than once occasion to rue the neglect of this precaution.

At Zapitiva, we met with excellent accommodations. The owner of the house at which we put up, furnished us with a plentiful supper of fish, fowls, coffee, and excellent sweet-meats, which we relished the more from having for eight days subsisted wholly on fish. Our lodgings were tolerably comfortable, and were rendered more so by the earnestness with which every one in the family strove to please

us. At sun-rise next morning, after diverting myself with shooting a few horned plovers on the beach, I took a survey of the romantic scenery around. Here are a few poor houses, and some plantations of indigo, sugar, and pulse. The beach is lined with fine aloes, and presents an interesting view of several islets in front of the bay, the most conspicuous of which is Madeira, before-mentioned. In another direction is seen that of Isle Grande. Four leagues distant from Zapitiva is Santa Cruz, formerly the property of the Jesuits, and now the royal farm of the Prince Regent of Portugal, of which I shall have occasion, in the sequel, to speak more at large.

After settling with our host, we hired mules to carry us to Rio de Janeiro, distant forty miles. Owing to the weight of our baggage, we travelled but slowly: this, however, we did not regret, as the fatigues of our coasting-voyage rendered us rather averse to violent exertion. Proceeding through a low sandy country, covered with wood, for about three leagues, we skirted the boundary of the Prince's farm, which encloses some of the finest and most fertile plains in South America, and gives employment to upward of fifteen hundred negroes. We soon afterwards reached the main road, which in general is very good, but the lands about it are little cleared, and seem almost destitute of cultivators. In the course of twenty miles, we saw only one house that deserved the name of a plantation; the only dwellings by the way-side were miserable huts and dram-shops, exhibiting deplorable symptoms of sloth and poverty. Before sun-set we halted at a kind of inn, where our mules were turned out to grass, and a supper was provided for us of fowls, milk, and coffee. The house, though pleasantly situated on an eminence among orange-groves and coffee-trees, was miserably deficient in those conveniences which its exterior had announced. The room where we supped was lighted by a small poor lamp, (here being no candles,) and the floor was so uneven, that our table stood on only two of its four legs. Tired with this cheerless gloom, we ordered our beds to be unpacked, and retired to rest. The want of candle-

light is a serious inconvenience to travellers in all parts of Brazil, and no one ought to undertake a journey without an ample provision of candles, with the necessary implements for using them. Snuffers are articles of luxury, very rarely to be met with, except as curiosities. I need not add that beds are an equally indispensable part of a traveller's equipage.

We resumed our journey at an early hour next day, along an excellent road in the middle of a valley, formed by lofty mountains. After travelling about three miles, we came to a house, called the Panedera (bake-house), which is reckoned half way between Zapitiva and the capital. From this place the road gradually becomes more enlivened by dwellings and plantations, (but many of the former are wretched hovels erected for the sale of bacon, corn, liquors, &c.) and by numbers of countrymen bringing produce from every part of the south-west, even from the far districts of Goyazes, Coritiva, Cuyaba, St. Paul's, and Mato Grosso. It is not uncommon to see eight hundred or a thousand mules passing and repassing in the course of a day, besides numerous droves of fine cattle for the use of the city. Our heavy-laden and weary mules travelled so slowly, that we did not come within sight of Rio de Janeiro, until about three in the afternoon. On reaching the eminence, which commanded the first prospect of this fine city, our joyful sensations banished every feeling of fatigue. One of the party, who had advanced a few paces, rode back as fast as his mule could go, exclaiming, "the English flag." We hastened onward, and beheld one of the most welcome sights that ever greeted the eyes of a traveller, with a remembrance of his native country — a squadron of our men of war at anchor in the bay, which had recently escorted the court of Portugal to an asylum in their own dominions, beyond the reach of their foes. We no longer felt uneasy at the thought of entering a large city inhabited by strangers; we knew that the name of Englishman would be a passport among them, and we anticipated something of that delight which is connected with the near prospect

of home. I, who had for eighteen months lingered in exile, and beheld each setting sun close another day of almost hopeless captivity, enjoyed this evening scene with indescribable emotion; it was here, that for the first time since my landing in South America, I had just reason to promise myself a night's repose in freedom, safety, and peace.

We soon reached the suburbs, which are very large and pleasant, being agreeably interspersed with gardens and pleasure grounds. About five o'clock we halted in the vicinity of Campo St. Anna, at an inn, or rather hostelry for cattle, whence, having secured our baggage in the miserable stall allotted to us, we sallied forth in search of the friends who left us at St. Catherine's. Accustomed, as we long had been, to rude and solitary scenes, we were forcibly struck with the opulence of this city, displayed in its magnificent buildings and regular streets. While engaged in anxious enquiries after our friends, we accidentally met with one of them, who, with unspeakable joy, conducted us to the rest, and the evening was passed most agreeably in relating over several encounters, and in asking and answering innumerable questions. Returning to our inn at midnight, we remained with our luggage until morning, when we carted it up to the house of our friends in Rua Pescadores.

During our journey from Zapitiva to Rio Janeiro, we had not much leisure for geological observation. The stratum, in the course of the route, is composed of primitive granite, like that before described. In some parts we observed large stones, approximating to basalt, and in other parts we found fine clay. Nearer to the capital, and particularly in the environs of St. Cristoval, the Prince's country-palace, the stratum has a gneiss-like appearance, and produces some fine specimens of feld-spar. In the precincts of the city, there is an extensive flat, covered with mangroves, and over-flowed by the tide. At the foot of the mountains which bound it, are quarries of granite, large blocks of which are raised for building purposes, as well as for paving the streets of the city.

CHAP. VII.

Description of Rio de Janeiro.—Trade.—State of Society.—Visit to the Prince Regent's Farm at Santa Cruz.

RIO DE JANEIRO has been so often described by former travellers, that, were I to confine myself to the supply of what they have omitted, or to the correction of their mis-statements, my task would be speedily performed, but, as I have uniformly chosen to write freely from my own observations rather than follow the track of others, I shall trespass on the reader with a more detailed account than he might perhaps require. It will, however, be recollected that the period at which I visited this capital being a political æra in the annals of Brazil, is sufficiently interesting to excuse if not to justify me in the attempt to improve upon descriptions of an earlier date, though at the risk of a little repetition.

The finest view of the city is from the harbour, whence its lofty eminences crowned with convents, and the hills in its environs, interspersed with villas and gardens, have a rich and magnificent appearance. The royal palace skirts the beach, and is seen to great advantage from the principal landing-place, which is within sixty yards of its doors. This palace, though small, is the residence of the Prince Regent and the royal family: the mint and the royal chapel form parts of the structure. Parallel with the beach runs the main street, consisting of noble buildings, called Rua de Dereito, from which the minor streets branch off at right angles, and are intersected by others at regular distances.

Some idea of the extent of the city may be formed from the population, which, including the negroes, (its most numerous portion,)

is estimated at a hundred thousand souls : the dwellings are generally of one story only.

The numerous convents and churches are well built, and rather handsome ; the cathedral, now nearly finished, is in a superior style of architecture. The streets were formerly incommoded by latticed balconies, which had a very heavy appearance and obstructed the circulation of the air, but they have been taken away by order of Government. The greatest nuisances now remaining are those which arise from the custom of persons of all ranks on horseback to ride on the foot-paths, and from the preposterous hanging of shop and house doors, which all open outward into the street, to the great annoyance of foot-passengers : I may also add the frequent pools of stagnant water which, from the lowness of the site, cannot without much labour be drained away, and which, through the heat of the weather, emit the most putrid exhalations. Water for the use of the city flows from the hills through aqueducts, and is distributed to several fountains in various public places. It is to be regretted that there are not more of these for the supply of the inhabitants, numbers of whom live a mile distant from any of them, and are obliged to employ persons continually in carrying water : many of the poorer classes earn a living by selling it. The fountains in dry weather are frequently so crowded, that the carriers have to wait for hours before they can be supplied. The water is good, and, when kept in large jars, drinks cool and pleasant. The inns and public houses are almost destitute of accommodations, and so very uncomfortable that a stranger will not reside in them if he can find a friend to take him in. House-rent in general is equally high as in London, owing, it should seem, to the dearness of building materials and the high price of masonry. Timber in particular is unaccountably scarce, considering the quantity which grows in almost every part of Brazil ; even fire-wood is dear. Provisions are in general plentiful, but not very choice in quality : the beef is very indifferent, and indeed bad ; the pork is better, and, if the feeding were properly attended to, might

be rendered fine; mutton is almost unknown, as the natives will not eat it*; the poultry of every description are excellent, but they are very dear. Pulse and vegetables of all kinds are very abundant, and the fish-market is not ill supplied. Turtles are frequently caught, as well as a great variety of fish; here are abundance of very fine large prawns. The oysters and muscles, though not equal to ours, are very tolerable.

Owing to its low situation, and the general filthiness of its streets, Rio de Janeiro cannot be called healthful. Improvements are now making which will in part remedy these evils; but other causes tend to increase the insalubrity of the air, and to spread contagious distempers, the principal of which are the large importations of negroes from Africa, who commonly land in a sickly state, the consequence of close confinement during a hot voyage. It is much to be regretted that the city was not originally built on the plan of those in the Netherlands, with canals for brigs and small vessels, which might then have been unloaded at the doors of the warehouses: such an improvement would have also greatly tended to the cleanliness and salubrity of the town.

The police is by no means ill regulated; and, from the attention which has been paid to it since the arrival of the court, there is every hope that it will be placed on a footing equally respectable with that of any European capital. The prisons are loathsome, and require the benevolent genius of a Howard to reform them altogether. One great step in favour of humanity has been gained: the inquisition has been abolished, and with it the spirit of persecution, so that no one can now be offended for his religious tenets, unless he openly insult the established religion.

* By way of experiment, I had some killed, and it was acknowledged by those who tasted it to be excellent; but some strange prejudice or other deters the inhabitants from introducing it at their tables.

This city is the chief mart of Brazil, and especially of the provinces of Minas Geraes, St. Paul's, Goyazes, Cuyaba and Corritiva. The mining districts, being most populous, require the greatest proportion of consumable goods, and in return send the most valuable articles of commerce; hence innumerable troops of mules are continually travelling to and from those districts; their common burden is about three cwt. each, which they carry to the almost incredible distance of 1500 or 2000 miles. Their homeward freight consists chiefly of salt for the consumption of the cattle, and iron for the working of the mines.

No colonial port in the world is so well situated for general commerce as Rio de Janeiro. It enjoys, beyond any other, an equal convenience of intercourse with Europe, America, Africa, the East Indies, and the South Sea islands, and seems formed by nature as a grand link to connect the trade of those great portions of the globe. Commanding also, as the capital of a rich and extensive territory, resources of immense amount and value, it seemed to require only the presence of an efficient government to give it political importance, and this advantage it has now gained by becoming the chosen residence of the court of Portugal. The benefits resulting from this great event had but just begun to display themselves at the period to which this narrative refers, and the commercial relations of Rio de Janeiro, though considerably augmented, were still but in their germ. I shall proceed to state them according to the best information I was then able to procure.

The imports hither from the River Plate, and from Rio Grande de St. Pedro, consist in immense quantities of dried beef, tallow, hides, and grain. Those from the United States are chiefly salt provisions, flour, household furniture, pitch, and tar. The North Americans generally send cargoes of these articles on speculation, and, as the market for them is fluctuating and not to be depended on, they frequently take them to other ports. Their provisions are commonly

sent to the Cape of Good Hope. They bring European merchandize, which they exchange for specie wherewith to trade to China, and also take in necessaries on their voyages to the South Seas.

From the western coast of Africa, Rio de Janeiro imports wax, oil, sulphur, and some woods. The negro trade has been restricted to the kingdom of Angola by a decree of the Prince Regent, who has declared his intention of abolishing it altogether as soon as possible.

The trade to Mozambique is trivial; but, since the capture of the Isle of France by the British has cleared that coast from French privateers, it may be expected to increase. It affords many valuable products, such as gold-dust, brought from the interior, ivory, of which the Prince monopolizes the largest sort, ebony and other fine woods, drugs, oil, excellent columbo-root, and an abundance of various gums, particularly of the gum meni. The whale-fisheries on the coast have proved a source of riches to many speculators.

The intercourse of this port with India, in common with Mozambique, has been much annoyed by the privateers of the Isle of France, and will therefore, in all probability, flourish equally by their suppression. A voyage thither and back is performed with great expedition: one large ship of eight hundred tons sailed, loaded at Surat, and returned within the space of seven months. A voyage to China seldom occupies a longer period. The trade thither will no doubt be revived, and it is not improbable that this port may at no great distance of time become an entrepôt for India goods destined for Europe.

Rio de Janeiro is conveniently situated for supplying a great variety of necessaries to the Cape of Good Hope and to New South Wales; indeed, of late years, English manufactures have been sold here so cheap that it has been found more advantageous to ship them hence for those colonies than from home. Ships going on the South Sea whale-fishery touch here, and lay in large stocks of spirituous liquors, wine, sugar, coffee, tobacco, soap, and live stock.

The imports from the mother-country consist chiefly in wine and oil. From Sweden some iron is occasionally brought: it is preferred to English iron for mules' shoes, on account of its greater ductility.

The exports consist principally of cotton, sugar, rum, ship-timber, various fine cabinet-woods, hides, tallow, indigo, and coarse cotton cloths, in immense quantities, for clothing the Peons in the provinces of the River Plate. Among the more precious articles of export may be enumerated gold, diamonds, topazes of various colours, amethysts, tourmalines (that are frequently sold for emeralds), chrysoberyls, aqua-marinas, and wrought jewelry.

This market has been greatly overstocked with English manufactures, in consequence of the sanguine speculations to which our merchants were incited by the late emigration. The supply exceeded the demand in a tenfold degree, and the excess gave rise to auctions where goods were sold at unprecedentedly reduced prices. In proportion as English merchandize lowered, that of Brazil rose in value, and so great was the demand for it, owing to the numerous vessels waiting for cargoes, that within a year after the arrival of the Prince Regent, every article of produce was doubled. Gold quickly disappeared; for the monied Portuguese, perceiving the avidity and impolitic eagerness with which the English forced their goods upon them, cautiously withheld their specie, and, by the alternative of barter, got rid of their own produce at a very high price, and obtained our merchandize almost at their own valuation. The losing party in this unequal traffic, though they had chiefly to blame their own imprudence in engaging in it, were loud in their complaints and remonstrances against the Portuguese merchants. A treaty of commerce was concluded, by which the duties on English, and indeed all foreign merchandize, which had been 25 per cent., were reduced to 15 per cent. ad valorem. A judge was appointed to attend solely to the concerns of the English, and to see justice done them: he was intitled the Judge Conservador of the English nation. The person who now fills this important office is one of the most enlightened and upright of

men ; his official conduct, of which I have seen much, has secured him the respect of all parties, and has done credit to the choice of the Prince Regent, confirmed by the approval of His Excellency Lord Strangford. Further to cultivate and extend the interests of commerce, His Royal Highness has established a Board of Trade, in which are some experienced and intelligent men, to whose consideration every particular case, and every new regulation, is referred. One of the members of this Board, Dr. Lisboa, has greatly distinguished himself by his zeal for the English nation, displayed in various publications on commerce, particularly in one dated May 1810, which contains a fund of solid argument on the principles laid down and acknowledged by our most celebrated statesmen and political writers. It is to be hoped that the diffusion of views so liberal, under the auspices of ministers, will banish that narrow-minded jealousy with which certain opulent individuals of the Brazilian capital regard the English merchants, whom they stigmatize as intruders ; and that the general interests of commerce in this thriving colony will gain, through fair competition, what they have heretofore lost through overstocked markets.

The business of the custom-house, although still shackled with many troublesome and tedious regulations, especially with regard to small articles, has been considerably simplified ; and, in all cases where a stranger finds himself at a loss how to proceed, he is sure to have every difficulty explained, and every obstacle removed, by appealing to the judge who presides over this department. The liberality and disinterestedness of this excellent officer are the more generally felt and acknowledged, from the inconveniences with which his situation might enable him to embarrass the trade, if he were inclined to a more rigorous execution of the laws.

In mentioning the advantages which have resulted to the English merchants from the liberality of the persons in office, I ought not to omit stating that much has been effected through the exertions of the British minister, who, while pursuing that conciliatory and moderate

line of conduct, which gained him the esteem of the Prince Regent, ever firmly upheld the interests of his nation, and in all deliberations concerning them reserved to himself the casting vote. With respect to individuals, it is true that he declined to be troubled on every trivial occasion, and scrupulously discountenanced every covert attempt at monopoly or speculation, from whatever quarter it came: but in great questions he acted with promptitude and decision; nor was he averse to use his influence in favour of a private individual, when a candid and manly appeal was made to him. Considering the peculiar circumstances attending his embassy, and also the jarring interests he had to reconcile, Lord Strangford has conducted himself in a way highly honourable to his talents and character; and in continuing to merit the confidence of his own court, has secured that of the Prince Regent and all his ministers. The treaty of commerce lately concluded is a proof of the harmony which subsists between them, and may be regarded on our part as the most advantageous that, in the existing posture of affairs, could have been procured.

The harbour is easy of entrance and egress, generally speaking, at all times, as there is a daily alternation of land and sea breeze, the former blowing until about noon, and the latter from that hour until sun-set. Ships find here every conveniency for repairing, heaving down, &c., but it is to be hoped that docks will soon be formed, which will render the latter troublesome and dangerous operation unnecessary. There is an anchorage-duty paid, which forms an item in the bill of port-charges.

Of the state of society in Rio de Janeiro, what I have to observe differs little from the description of the Paulistas already given. The same habits and manners prevail at both places, allowing for some slight variation, caused by the greater influx of strangers to the capital. The Portugueze are in general rather punctilious and reserved in admitting a foreigner to their family parties; but having once received him, they are open and hospitable. The ladies are affable and courteous to strangers, extremely fond of dress, but less

proud than those of other nations. In their mixed assemblies the utmost gaiety prevails, and is seasoned by that finished politeness for which the Portugueze are generally distinguished. The conversation of the best-bred men, however, is more lively than instructive; for education is here at a low ebb, and comprehends a very limited course of literature and science. It is proper to add that, since the arrival of the court, measures have been adopted for effecting a thorough reform in the seminaries, and other institutions for public instruction; and that the Prince Regent, in his solicitude for the good of his subjects, has zealously patronized every attempt to diffuse among them a taste for useful knowledge. Under his auspices, the college of St. Joaquim has undergone considerable improvement: a lectureship on chemistry has been instituted, to which our countryman, Dr. Gardner, has been nominated by His Royal Highness; and it is to be hoped that from this appointment may be dated the introduction of experimental philosophy in that establishment.

Resuming my narrative, I am bound in gratitude to state that the reception I met with here exceeded my most sanguine hopes, and far more so any individual pretensions on which I could ground them. I must attribute it to the letter of introduction to the Viceroy, with which the Portuguese ambassador in London honoured me on my departure thence, and which I presented to the ambassador's noble relative, the Condé de Linhares, minister for foreign affairs. This distinguished statesman shewed me every attention, and granted me every privilege I could ask, so that, through his kind condescension, all went well with me. I may state this without incurring the imputation of vanity, since it is only one among the numerous proofs he has given of his disposition to serve the English by every means in his power.

A few weeks after my arrival, I solicited permission of His Excellency the Condé de Linhares to work an iron mine at Guáraceaba, representing at the same time the immense advantages which might

accrue to the state from such an experiment, by opening its own resources for the supply of that useful metal. He in part assented to the proposal, but expressed a wish that I should previously devote a few days to an inspection of the Prince's farm at Santa Cruz, and on my return make a report of the state in which I found it. While preparing for my journey, it was intimated to me as the Prince's particular desire, that I should endeavour to establish a dairy on the principle of those in England, and direct the people in the management of it, to which I readily assented. Being provided with horses and a soldier to attend me, I set out on the journey, accompanied by a gentleman named Paroissien, whose amiable disposition and scientific pursuits rendered him a very useful companion. After about fifty miles hard riding, we arrived at the farm about six in the evening, much fatigued. The accommodations we met with, fully explained to me the motive of His Royal Highness's minister in enquiring into the state of his domain. Having presented my official letters, I was obliged to wait until ten o'clock before the slightest refreshment could be procured; not a dish of coffee was to be had; the only fare set before us was some lean beef half-boiled, certainly the worst I had ever tasted in Brazil. The mulatto who attended us engaged to have breakfast ready by seven next morning; we were in readiness at the hour, and though told it was coming immediately, we waited three hours, when just as we were ordering out the horses to Rio to avoid being famished, the repast was announced, with an excuse that it could not come sooner, because no milk could be procured.

I then took a survey of the establishment and rode over the grounds. The house, I was informed, was once a convent of Jesuits, who possessed also the extensive tract of land attached to it, which they managed much better than their successors, if we may judge by the remains of their undertakings. The edifice is neither large nor grand: it is built in a quadrangular form, with an open court in the centre, and galleries inside to the first and second floors. The

apartments are thirty-six in number, very small, having been adapted to the use of the brotherhood, and since their departure only in a slight degree altered and decorated for the reception of the Royal Family, as their summer residence. In front of the house, to the southward, extends one of the finest plains in the world, two leagues square, watered by two rivers navigable for small craft, and bounded by fine bold rocky scenery, embellished in many parts with noble forest trees. This plain is clothed with the richest pasture, and supports from seven to eight thousand head of cattle. A considerable part of it lies low, and abounds with bogs which might easily be laid dry and rendered cultivable by proper drainage. The park occupies in its entire extent upwards of one hundred square miles, a territory almost as large as some of the late principalities of Italy, and capable, by its proximity and connection with the capital both by land and water, of being rendered one of the most productive and populous in Brazil. Under the present system of management it is in a progressive state of deterioration; two small corners, the best of the land, one about half a league square and the other more than a league square, have been already, through disingenuous artifices, sold off, and the rest may in no long time be sacrificed to men whose cupidity stimulates them to depreciate its value, unless proper means are used to thwart their nefarious designs.

The negroes on this estate, including all descriptions, amount to about fifteen hundred in number. They are in general a very excellent class of men, tractable and gentle in their dispositions, and by no means deficient in intellect. Great pains have been taken to enlighten them, they are regularly instructed in the principles of the Christian faith, and have prayers publicly read to them morning and evening, at the commencement and close of their day's labour. Plots of ground, at their own choice, are assigned to each, and two days in the week, besides the incidental holidays, are allowed them to raise and cultivate produce for their own subsistence; the rest of their time and labour is devoted to the service of His Highness.

The system of management, however, is so bad, that they are half-starved, almost destitute of clothing, and most miserably lodged; their average earnings do not amount to a penny per day each. A reform in the establishment might have been easily effected on the arrival of the Prince Regent, but it will now be very difficult, as the abuses have been tacitly sanctioned by the indifference of those whose duty and interest it was to correct them. In this extent of fine ground scarcely an inclosure is made; the cultivated lands are full of weeds, and the coffee-plantations are little better than a mere coppice-wood, in which the wild shrubs grow higher than the coffee-trees. The cattle are most deplorably neglected, and there is not upon the whole premises a horse fit for the meanest beggar to ride. Such was the state in which I found this rich and extensive district, which seems to have been destined by nature for the introduction of improvements that might produce, through the influence of high example, an entire change in the agricultural system of Brazil.

A short time after I had taken up my residence at Santa Cruz the Prince came down, and on the day succeeding his arrival honoured me with a visit, after which I frequently rode out with His Royal Highness. He one day did me the honour to express a wish that I would undertake to govern the farm; this proposal I begged leave to decline on the ground of my inability to render such an employ compatible with my other concerns, suggesting at the same time the superior service I could render by working the iron mine. Notwithstanding this, the Prince, on the day following, gave me a paper, containing an offer of the whole direction of the estate and stating the terms. The repetition of the proposal not a little embarrassed me; I was aware that, by refusing, I might probably debar myself from the prospect of any future favour, yet I anticipated enough of difficulty in the undertaking to make me decline it at all events. This dilemma occasioned me much uneasiness, and in order to remove it I applied to Sir Sidney Smith, who was then on a visit to Santa Cruz, requesting him to explain to His Royal Highness the

circumstances which rendered it impossible for me to settle in Brazil, and to tender him the offer of my services during my stay. After some further deliberation, however, I was induced to accept the appointment, by way of trial, for a few months, under the express stipulation that I should act *without control*. On entering upon my charge I began by making such new arrangements as appeared conducive to the end for which I was appointed, but I soon perceived that instead of being principal intendant, I had a superior, who held me accountable to him for my proceedings, and manifested a fixed determination to thwart them, as innovations on the established course of things. But this was not the only inconvenience; it was expected that I should purchase whatever was wanted on my own credit; but I quickly discovered, that instead of being reimbursed, according to agreement, I was trifled with and at length in part defrauded. The person to whom I allude was one of the managers of the Prince's household; he had conceived a rooted hatred against the English, and could not bear that one of that nation should interfere in a concern over which he claimed authority, and hold a situation where real services might induce a comparison unfavourable to those specious ones which he contented himself with rendering. I will not detail the petty artifices and mean indirect insults which this man employed, to disgust me with the situation, when he found I would not submit to be his servile drudge; suffice it to say that, perceiving no chance of obtaining that discretionary power, which alone could enable me to be essentially useful, I peremptorily refused to act any longer. Alarmed at this determination, he at first strove to overawe and then conciliate me, but I had seen too much of his conduct to be duped by this stratagem, or to suppose that any cordiality could in future subsist between us. Imagining himself armed with Royal power, he attempted to play the tyrant, but the reception he met with quickly forced him to resume his natural character, that of a cringing sycophant. I did not hesitate to send in my resignation, and he had

the mortification to find that the means he had employed to embarrass and enslave me, restored me to liberty.

In the letter which announced my determination to give up the employ, I thought proper to omit stating to His Excellency Don Rodrigo the reasons that led me to this step,. Had that nobleman been apprised of the disagreeable circumstances in which I was placed, he would, I am confident, have done his utmost to remove them, but I deemed it beneath me to remonstrate, seeing that while this man remained I was to be considered as serving the Prince's servant and not the Prince. A condition so degrading must ever deter any Englishman from undertaking to execute the excellent and enlightened plans which His Royal Highness's ministers have projected, for improving the agriculture of Santa Cruz; for who would submit to the dictates of an underling, whose arrogance and obstinacy are continually interrupting and frustrating those plans?

On my return to Rio de Janeiro, the Prince sent for me, and desired me again and again to return to Santa Cruz; I contented myself with a simple excuse; for that was not a time, nor was I in a place to enter into explanations. It is well known, that a system of intrigue prevails near His Royal Highness's person, which often tends to counteract representations on matters of the greatest importance.

CHAP. VIII.

Journey to Canta Gallo.

SOME time after my return from Santa Cruz, a circumstance of a singular nature took place, which occasioned me to undertake a journey to a district called Canta Gallo, distant about forty leagues from the capital, and one of the latest discovered in this part of Brazil. Two men reported that they had there found a mine of silver, and brought to the mint a quantity of earthy matter reduced to powder, from which was smelted a small ingot of that metal. This report being officially laid before His Excellency Don Rodrigo, I was solicited to go to Canta Gallo and investigate the business on the spot, the two men being ordered to meet me there. Before I proceed to relate the result of my inquiry, I shall briefly describe whatever I observed worthy of note in the course of the journey.

Being provided with a passport, and also a sketch of the route, taken from a MS. map in the archives, I departed from Rio on the 10th of April 1809, accompanied by Dr. Gardner, the gentleman already mentioned as lecturer on chemistry at the college of St. Joaquim. Having to pass to the bottom of the harbour, towards the north, we embarked in a small vessel, and being favoured with a strong sea breeze, ran down to the entrance of the fine river Macacu, which we reached after a five hours' sail. The wind then dying, our boatmen took to their oars, and proceeding up the river we reached a house called Villa Nova, where numbers of market-boats for Rio were waiting for the land-wind and the turn of the tide. After taking some refreshment here, we rowed onward until the river became so narrow that the vessel frequently touched the bank on

each side, and the men were obliged to push her along with poles. At day-break we reached Porto dos Caxhes, a place of great resort from the interior, being the station where the mules discharge their loads of produce from the many plantations in the neighbourhood. The town consists of several poor houses, and of stores where goods are deposited for embarkation. The stratum hereabouts is primitive granite, covered with fine strong clay. Leaving this place, we proceeded for some distance and came to a large swamp, which we navigated in a canoe, with very little difficulty, and shortly afterwards arrived at the village of Maccacu. It stands on a small eminence in the midst of a fine plain, watered by a considerable stream, over which there are two good bridges. Though almost at the base of the chain of mountains that forms a barrier along the coast, the neighbourhood affords some fine situations; the land in general consists of a strong clay, but appears much worn out. The commander, Colonel José, to whom I introduced myself, gave me a very polite reception, as did also the brethren of the convent, to whom I paid a visit. I passed the night at the house of the Escrivano, a worthy gentleman, whose hospitality I still remember with peculiar gratitude, because it seemed to proceed, not from a cold sense of duty, but from the impulse of a warm and generous heart.

On the following day, being accommodated by the colonel with a horse and guide, I proceeded along the winding banks of the river, which in many places present most beautiful views. Here was more cultivated land than I expected to see; but the sugar-plantations, and, in general, the low pasture-grounds, are quite neglected. We passed several farms belonging to convents, which, from their apparent condition, and the accounts we received, do little more than maintain the negroes and incumbents upon them. There was rarely a milch cow to be met with; pigs and poultry were equally scarce. The population of these fine valleys is deplorably thin and poor; there was a general sickliness in the looks of the women and children we met with, which may be imputed to their miserable diet and

inactive life. I ought to state that the manners of the people here are mild and gentle ; we were every where treated with civility, and all our enquiries were answered with the most friendly marks of respect and attention.

The air, as we drew nearer the mountains, was fresh and indeed cold. Towards evening we arrived at a farm belonging to a convent of nuns in Rio de Janeiro, where we were kindly accommodated for the night. This place is most agreeably situated, and might, under skilful and industrious management, be rendered a paradise. It has excellent clay ; fine timber ; a good fall of water, which forms a beautiful rivulet, and runs into a navigable river within one hundred yards of the house ; a fine extent of arable land, and a still finer of pasture, which peculiarly qualifies it for dairy farming. It is distant only one day's journey from Port Caxhes, whence there is a navigable communication with the metropolis. What a scene for an enterprising agriculturist ! At present all is neglected : the house, the out-buildings, and other conveniences are in a state of decay, and the people who manage the land appear, in common with the animals that feed upon it, to be half famished.

The next morning we proceeded eastward, and crossing the stream, which was at least sixty yards broad and full three feet deep, rode along the farther margin, which is rather more elevated, and presents a view of some fine plains, stretching from thence to the base of the mountains. Journeying in that direction we reached the fine plantation of Captain Ferrera, who received us very politely, and shewed us every attention. This place, bounded by the alpine ridge behind it, is the extreme point to which the river Maccacu is navigable. It is six or seven leagues from the village of that name. The estate maintains about one hundred negroes, who are chiefly employed in raising sugar, cotton, and coffee ; but to me the situation appeared much better calculated for growing grain and feeding cattle, as the weather is at times cold, the evenings are frequently attended with heavy dews, and owing to the proximity of

the mountains, here are frequent rains, accompanied by thunder and lightning. Numbers of fine springs burst forth from various parts of the hills, and form rivulets with falls, which, as here is plenty of fine timber, afford every means for working machinery. The owner lives in opulence, and is so humane and liberal to his people, that they seem to revere him as a father. We were much pleased with the air of domestic comfort and contented industry, which we observed among them on visiting their dwellings in the evening. Some of the negro-children were at play ; others of more advanced age were assisting the women to pick cotton ; and the men were scraping and preparing mandioca. Their cheerfulness was not at all interrupted by our approach, nor did they betray any uneasy feeling of constraint in the presence of their superiors. In lieu of candles, which are seldom to be met with but in the capital, they burn oil, extracted from the bean of the palm, or from a small species of ground-nut, here called meni.

About noon, on the following day, horses being provided, and a soldier appointed for our guide, we left the fazenda, accompanied by its hospitable owner, Captain Ferrera, who conducted us half a league on our way. The river, along which we passed in an easterly direction, bursts through vast masses of rock with great force, and in some parts forms considerable falls. The Captain, ere we parted, led me to a water-course, in which were found pieces of granite covered with manganese in a botryoidal form. After crossing the river twice, we arrived at what is called the first register, or searching-house, distant about two miles from the fazenda. This station is guarded by a corporal and a private soldier, who are charged with the receipt of various tolls, and are empowered to search passengers, in order to prevent the smuggling of gold-dust. After shewing my passport, I took leave of Captain Ferrera, who made me promise to pay him a longer visit on my return.

We had been warned of the badness of the roads, and were by no means agreeably deceived in them, for we were nearly four hours

in going the next six miles. At the close of day, after a laborious and dangerous passage through abrupt ravines, and along the sides of steep hills, our guide announced that we were in sight of the second register, where it was proposed that we should pass the night. On arriving we found it a most miserable place, inhabited by five or six soldiers under the command of a serjeant. This good man gave us a hearty welcome, and with the assistance of his comrades, cooked us a supper of fowls, and regaled us with whatever else their scanty store afforded. We were not without music to our repast, for the house is built on the edge of a roaring torrent, which, bursting through a ravine, has washed away every thing except some huge masses of rock. A bit of ground, about ten yards square, is all the garden these poor people have, and even this is much neglected, for the guards here are so often changed, that no one thinks of adding to the comforts and conveniences of an abode, which others are to enjoy.

At day-break, we found that our mules had strayed into a wood adjoining, but as the road was stopped, we were under no apprehension of losing them, for the thickets on each side were impervious. This occurrence gave me an opportunity of seeing more of these remote regions, and certainly the imagination of Salvator Rosa himself never pictured so rude a solitude. On one side rose the great barrier of mountains, which we had yet to cross, covered to their summits with trees and underwood, without the smallest trace of cultivation ; on the other lay the broken country, between this ridge and the plain, presenting the same wild features of sylvan scenery. The miserable hut, at which we lodged, partook of the savage character of the neighbourhood, and seemed formed for the abode of men cut off from all intercourse with their fellows. On our return we were provided with a breakfast of coffee and eggs ; as to milk, there was no possibility of procuring any ; a cow would have been considered here as an incumbrance, nor would any one of the six idle soldiers

have given himself the trouble of milking her, though they all had been dying of hunger.

On resuming our journey, we entered on a road still more steep and rugged than that which we had passed. We were often obliged to dismount and lead our mules up almost perpendicular passes, and along fearful declivities. In some places, the thick foliage of the trees, and that of the underwood, which grew higher than our heads, sheltered us from the sun, and indeed scarcely admitted the light. Not a bird did we see, nor the trace of any living thing, except some wild hogs. We passed several bare granite rocks of a gneiss-like formation.

In journeying to the next station, we observed nothing worthy of note except a small saw-mill, worked by an overshot wheel, of very clumsy construction. The frame, which contains a single saw of very thick iron, moves in a perpendicular direction; at every stroke, a boy brings the timber up, by pulling a cord attached to a crank that moves the cylinder on which it rests. How readily, thought I, would the meanest Russian peasant improve this machine!

We proceeded on our way up an ascent so precipitous, that we were obliged to walk more than ride; after two hours toiling along the side of a granite mountain, in which we observed some beds of fine clay, we reached the summit, from whence we saw the bay of Rio de Janeiro, the sugar-loaf mountain, and the city itself, to all appearance not more than four or five leagues distant from us, though, in reality, more than twenty. At this elevation, which we may state to be at four or five thousand feet above the level of the sea, the air was sharp and keen; the thermometer stood at 58°. Continuing in a north-easterly direction, we passed two poor solitary farms, and entered upon a range of scenery tremendously grand, composed of bare abrupt conical mountains, with immense waterfalls in every direction. At the close of day, we arrived at a farmhouse, called Fazenda do Moro Quemado, the manager of which

received us hospitably, and accommodated us for the night. The weather was so cold, that a double supply of bed-clothes scarcely produced sufficient warmth; in the morning the thermometer was at 48° Fahrenheit. After the heavy dew cleared away, we took a view of the grounds, in company with the manager; they appeared well-suited for a grazing-farm, but the temperature of the atmosphere is too severe for growing the common produce of the country; particularly cotton, coffee and bananas, which are frequently blasted. I was informed that some wheat has been grown here, though the people are quite unacquainted with the European method of farming. Indian corn, for the feed of hogs, is the staple article. This plantation is infested by ounces, which at times prey upon young cattle; the manager, who is a great hunter, keeps dogs, though of a poor race, for the express purpose of destroying them, which is thus practised:—When the carcass of a worried animal has been found, or when an ounce has been seen prowling about, the news is soon proclaimed among the neighbours, two or three of whom take fire arms loaded with heavy slugs, and go out with the dogs in quest of the animal, who generally lurks in some thicket, near the carcass he has killed, and leaves so strong a scent, that the dogs soon find. When disturbed he retreats to his den, if he has one, the dogs never attempting to fasten on him, or even to face him, but, on the contrary, endeavouring to get out of his way, which is not difficult, as the ounce is heavy and slow of motion. If he caves, the sport is at an end, and the hunters make up the entrance; but he more commonly has recourse to a large tree, which he climbs with great facility; here his fate is generally decided, for the hunters get near enough to take a steady aim, and seldom fail to bring him down, one of them reserving his fire to dispatch him, if required, after he has fallen. It generally happens, that one or two of the dogs are killed in coming too near, for even in his dying struggles, a single stroke of his paw proves mortal. The skin is carried home as a trophy, and the neighbours meet and congratulate each other on the occasion.

This farm, in the hands of an experienced and skilful agriculturist, might be managed so as to produce amazing returns. Its soil is wet, adapted to the growth, not only of Indian corn, but of wheat, barley, potatoes, &c. and it is so well irrigated, by numerous mountain streams, that the pastures are always luxuriant. Here are fine falls of water, and abundance of excellent timber, so that corn-mills might be erected at little more expence than what would arise from the purchase of mill-stones. Connected with the nun's farm below, this establishment might be rendered one of the most complete and advantageous in Brazil.

Leaving Moro Quemado at noon, and descending on the other side of the ridge of mountains, we passed through an unequal tract, formed of hills and ravines. Onward the land appeared finer, and the timber of a superior growth, but there were few cultivated spots, and not many houses. The first extensive fazenda we reached was that of Manuel José Pereira, a native of the Azores, who managed his agricultural concerns much better than the other farmers whom we visited. We were shewn a large field of Indian corn, ready for cutting; the quantity that had been sown was about eleven fanegas, or bushels, and the produce was estimated at fifteen hundred bushels, about one hundred and fifty for one. This was an ordinary crop; in good years the harvest yields two hundred for one. The corn, as before stated, is chiefly consumed in the fattening of pigs; the quantity requisite for this purpose is six or seven bushels each, and the time, ten or twelve weeks. The curing of bacon is performed by cutting all the lean from the flitches, and sprinkling them with a very little salt. This food has the peculiar effect of giving greater solidity to the fat, which of itself is not liable to putrefaction.

Though the owner of this farm has occupied it not more than five years, and has had only the assistance of his two sons, and six negroes, he has brought it into a very fair state of cultivation. In his coffee plantation we observed five thousand trees in full bearing, and the rest of his grounds were in an equally prosperous condition.

His expences, indeed, are light, and the only difficulties he has had to contend with, have been the bad roads, which are now much amended. The example of this man, it is to be hoped, will stimulate the emulation of his neighbours ; for it has fully shewn the unbounded liberality with which nature here crowns the labours of the agriculturist.

On our way hence to the place of our destination, we passed through some forests of fine full-grown trees ; one which had fallen, I had the curiosity to measure ; it was full seventy-six inches in diameter, at the thick end, and above twenty-five yards in length. Such a piece of timber I had never before seen. Within about three miles from Canta Gallo, we arrived at an excellent farm belonging to the Senhor Tenente, or treasurer of the district, who treated us very hospitably, and invited us to visit him on our return. Our reception at Canta Gallo was highly gratifying ; the Governor, and all the principal inhabitants, overjoyed to see Englishmen in these remote parts, treated us with great cordiality and friendship ; a dinner was provided, at which they testified to us the great respect they entertained for our nation, as being the great ally of a Prince whom they adored.

CHAP. IX.

*Description of Canta Gallo.—Of the Gold-washing of Santa Rita.
—Account of the supposed Silver-Mine.*

CANTA GALLO, though so near the seat of government, was not known until about twenty years ago. It is situated in the midst of a fine well-wooded country, abounding in springs, and intersected by narrow valleys and ravines. The bottoms of some of these ravines formerly contained gold, which was accidentally discovered by some grimperos * from Minas Geraes, in the course of their searches about the great river Paraiba, and the Rio Pumba. The richness of these beds of gold, and the fertility of the circumjacent country, attracted numbers of adventurers, who placed themselves under the direction of an able chieftain, named Mão de Luva, on account of his having lost one hand, and his wearing a stuffed glove in its place. The band soon amounted to two or three hundred persons, who washed every part in the neighbourhood worth washing, before they were discovered. Being very determined men, they lived free of control, and bade defiance to the laws. It was not until about three years after their first settlement, that the existing government was apprised of them; when, alarmed at the report of their numbers, which was doubtless exaggerated, they sent out spies to discover their rendezvous. This, after much time and great difficulty, was effected; the spies, in wandering through the solitary woods and fastnesses in the neighbourhood, were attracted

* A name given to those persons who go about the country seeking gold-washings, and do not give notice, or solicit a grant when they discover any. They are considered and treated as smugglers.

toward the place, by the crowing of a cock :— hence the name of *Canta Gallo*, which was subsequently given to it. They introduced themselves as smugglers, who wished to belong to the fraternity, and after living there some time, found means to give information to government, at Rio de Janeiro, who issued proclamations, offering pardon if the whole body would surrender. This measure was ineffectual ; the grimperos were well provided with fire-arms, and determined to defend themselves as long as any gold could be found. In a year or two afterwards, the washings began to fail, and thus the great bond of interest which united them being loosened, some deserted the place, and the rest became less vigilant in taking measures for their defence. The government seized this favourable opportunity of reducing them ; a considerable force was assembled in the vicinity, with orders to make an attack at a certain fixed day, which was known to be celebrated by the grimperos as a festival in honour of some saint. At the expected time, while they were engaged at a great banqueting, and too much occupied with their wine to think of their arms, which had been laid aside, (the flints having been secretly taken out,) about a hundred soldiers rushed in among them ; those who were sober enough flew to their arms, exclaiming, “ We are sold ! we are betrayed ! treason ! treason ! ” The contest was short ; the soldiers seized the ringleaders, who were either sent to Africa, or imprisoned for life ; of the rest, some were taken prisoners, others fled, but were pursued for years afterwards, and a few fell in the attack.

The Government, having thus become masters of this territory, and imagining it to be as rich in gold as when the grimperos first settled there, issued many injudicious regulations, oppressed the natives beyond example, built registers in various parts, to prevent contraband, and filled the whole neighbourhood with guards. The numerous settlers, whom the supposed richness of the place afterwards attracted, soon found that the cream had been skimmed by the smugglers, and by degrees turned their attention to agriculture, a

less precarious subsistence than mining. So little gold is at present found, that His Highness's fifth scarcely pays the officers and soldiers appointed to receive it. There are some situations alike favourable to mining and farming; with a small capital, a man may here turn both pursuits to account, if he can bring himself to conform to the customs of the place. The land is strong and good; its various inequalities present spots adapted to the growth of almost every description of produce. In the valleys, and on the sides of the mountains, the soil, in some parts, consists of strong clay, but more generally of a fine, rich, vegetable mould. The rock, or solid stratum, which appears at various depths below it, is granite, composed of feld-spar, hornblende, quartz, mica, and frequently garnets. When found in a decomposing state, it is denominated *pizarra*. No metallic substances, except gold and oxides of iron, appear; the former, which is found in the interjacent bed of *cascalhão*, exists only in grains; I examined a considerable quantity, but could not discover a single particle in a crystallized state.

The country appears to be very poorly stocked with cattle; no cows are kept for milking, nor is any attention here paid to the production of an article of diet, so essential to the subsistence of a poor family; a few goats are kept, and the only milk used is that which they yield. The common food of the inhabitants is as follows;—for breakfast, a kind of kidney beans, called *feijones*, boiled, and afterwards mixed with the flour of Indian corn; for dinner, *feijones* boiled with a little fat pork and some cabbage leaves, and a sort of pudding, made by pouring the water from the pork on a plate of the *farinha*, which is eaten with the hand, and much relished; for supper, some poor vegetables, also boiled up with fat pork. Fowls, which are bred here in great numbers, are generally cut to pieces and stewed for table. Wine is rarely used, even among the higher ranks, but here are fruits in great abundance, particularly bananas and oranges, which form a considerable part of the general diet.

Very little sugar is grown here: the principal articles of produce sent to the capital are corn, bacon, fowls, jaracanda, or rose-wood, and ipecacuanha. In many parts of the neighbourhood is found a tree, the bark of which has been successfully used as a substitute for the quinquina of Peru.

In one of the frequent excursions I took in the neighbourhood of Canta Gallo, previous to my journey to the reputed silver mine, I obtained some information respecting the half-civilized aborigines of the district from a man who employs himself in procuring ipecacuanha, and is a kind of chief among them. They reside in the woods, in a most miserable condition; their dwellings, some of which I saw, are formed of boughs of trees, bent so as to hold a thatch or tiling of palm-leaves; their beds are made of dry grass. Having little idea of planting or tillage, they depend for subsistence almost entirely on their bows and arrows, and on the roots and wild fruits which they casually find in the woods. The chief above-mentioned brought about fifty of these Indians to pay me a visit, which was not a little gratifying to me, as it afforded an opportunity of examining their features, and of conversing with the few among them who could speak a little of the Portuguese language. The dress of the men consisted of a waistcoat and a pair of drawers; that of the women, of a chemise and petticoat, with a handkerchief tied round the head, after the fashion of the Portuguese females. They bore the general characteristics of their race, the copper-coloured skin, short and round visage, broad nose, lank black hair, and regular stature, inclining to the short and broad-set. Being desirous to see a proof of their skill and precision in shooting, of which I had heard much, I placed an orange at thirty yards distance, which was pierced by an arrow from every one who drew his bow at it. I next pointed out a banana-tree, about eight inches in circumference, at a distance of forty yards; not a single arrow missed its aim, though they all shot at an elevated range. Interested by these proofs of their archery, I went with some of them into a wood to see them shoot at birds;

though there were very few, they discovered them far more quickly than I could ; and, cautiously creeping along until they were within bow-shot, never failed to bring down their game. The stillness and expedition with which they penetrated the thickets, and passed through the brush-wood, were truly surprising ; nor could any thing have afforded me a more satisfactory idea of their peculiar way of life. Their bows are made of the tough fibrous wood of the Iri, six or seven feet long, and very stout ; their arrows are full six feet long, and near an inch in diameter, pointed with a piece of cane cut to a feather edge, or with a bone, but of late more frequently with iron. They are loathsome in their persons, and in their habits but one remove from the anthropophagi ; for they will devour almost any animal in the coarsest manner, for instance, a bird unplucked, half-roasted, with the entrails remaining*. They are not of a shy or morose character, but have a great aversion to labour, and cannot be brought to submit to any regular employment. Rarely is an Indian to be found serving as a domestic, or working for hire, and to this circumstance may be ascribed the low state of agriculture in the district ; for as the farmers, when they begin the world, have seldom funds sufficient to purchase negroes at Rio, their operations are for a long time very confined, and frequently languish for want of hands. What benefits would result to the state, and how much would the general cause of humanity be served, if these Indians were civilized and domesticated ! A tribe of idle and unsettled savages would be converted into useful and productive labourers ; the whole face of the district would be improved ; the roads which at present connect

* Ere they departed, I saw an instance of that dangerous excess to which the passions of savages are liable when once excited ; for, on presenting a few bottles of liquor, there was a general strife for them, and the person, man or woman, who first obtained one, would have drunk the whole of its contents, had it not been forcibly taken away. It is very unsafe to give them ardent spirits, for when intoxicated it is necessary to confine them. If preference is given to one, the rest are insolent and unruly until they obtain the same marks of favour.

it with the capital would be cleared of the thousand inconveniences which now encumber them, and new ones* would be opened for the more expeditious conveyance of its produce.

During my stay at Canta Gallo I undertook a journey to the gold-washing at Santa Rita, distant about five leagues, in a north-east direction. After passing the uneven country in the immediate neighbourhood of the village, we arrived at the Rio Negro, a considerable stream formed by many rivulets, which empties itself into the Paraíba; on crossing it †, we entered upon a fine open country, the fertility of which was evident from the luxuriant growth of the tobacco and other plants: but it lay in a state of almost total neglect, and the families thinly scattered upon it appeared in the lowest condition of indolence and misery. We proceeded a league farther, through a tract entirely destitute of inhabitants, and arrived about two in the afternoon at Santa Rita. The proprietor of the works received us very kindly, and conducted us through them while dinner was preparing. The washing is in a deep ravine, bounded at one end by an abrupt hill, and open at the other to the plain. The vegetable earth appeared extremely rich, being clothed with luxuriant verdure, and the hills on each hand covered with trees of all sizes. The stratum of cascalhão, which lies under a bed of soil four or five feet deep, is very thin and uneven, being no where more than two feet thick, and in many parts not more than seven or eight inches. The incumbent soil is removed at great labour and expence, being dug out and carried away in bowls; and the cascalhão is conveyed with great care to a convenient place for water, where it is washed by the most expert among the miners, in a way similar to

* I was well informed that a few hundred pounds, judiciously employed, would defray the expence of making a good road from Canta Gallo to Porto dos Caxhes, which loaded mules might travel in two days.

† The mode of crossing a river with horses or mules in these parts, is to tie one to the canoe, and drive him into the water; the rest follow.

that practised at the mines of Jaragua. The proportion of gold produced was moderate: I was informed that it paid the master at the rate of from fourteen pence to two shillings per day for each negro, which is a large profit, as the daily subsistence of one costs somewhat less than a penny.

The sides of the ravine towards the top were bare, and of different shades of colour, being tinged by the water which flows from the vegetable matter above: in the bottom, on the surface that was yet unworked, lay some huge, half-rounded, amorphous masses. In the parts which had been worked, I observed two or three substances of the same kind, which being too large to be moved, the earth which imbedded them had been cut away, and they appeared like detached nodules. On breaking a fragment from one of them with my hammer, I was much surprised to find it a calcareous substance, a solid mass composed of hexagonal crystals, with a small portion of brilliant crystals of specular iron ore. I presented this fragment to the proprietor, informing him that it was limestone, at which he was truly astonished, having never before heard of stone lime*; nor would he believe me until I proved it by calcination. The mountains, as I afterwards found, are of the same substance.

As I stood observing the heavy operation of cutting and carrying away the surface to get at the cascalhão, it occurred to me that much time and labour might be saved by arching the work with brick; but, on suggesting the idea, I was informed that the sole or bottom was quite decomposed, and subject to much water.

There is reason to suppose that the stratum of limestone, below the earth in the bottom of the valley, is of very modern formation, and that, if not too thick to cut through, there might be found, between it and the granite stratum underneath, a bed of cascalhão of prior formation, much richer in gold than the upper stratum.

* The little lime which they use here is made of shells, and is brought from Porto dos Caxhes.

After having investigated these works, we took an excursion of seven or eight miles, chiefly over a rich plain abounding with the finest timber. On the margins of the rivulets which we crossed, I observed that the moss was incrustated, somewhat like the tuffa at Matlock; and, on more particular examination, I found a stratum of tuffa in all the valleys, a few inches below the surface, which, as I conjecture, must have proceeded from the deposition of calcareous matter by the overflowings of the streams after heavy rains. The hills even at this distance were composed of the same sparry limestone as at the gold-washing. It is much to be wished that the value of this material were duly appreciated at the capital, where the cost of the wood used in burning shells into lime exceeds the price at which lime brought from Santa Rita might be delivered, if proper roads were made for its conveyance from this district to Porto dos Caxhes. Such an undertaking highly deserves the attention of His Highness's ministers; the benefits likely to result from it are incalculable, and the expence attending it would be trifling; for in no part of the globe are roads made so cheaply, or public works of any kind done on such moderate terms, as in Brazil.

This fine but almost uninhabited district produces spontaneously many valuable articles of commerce, which run to waste for want of hands to cultivate and gather them. Here is found that celebrated variety of the palm-tree, the long, serrated, lancet-formed leaves of which are composed of innumerable fibres, that rival silk both in fineness and strength. I bought some fishing-lines made of them for a mere trifle; and I have no doubt that, if proper means were employed to propagate the growth of the trees, this valuable substance might be produced in as great plenty, and at as cheap a rate, as flax is in England. I laid before His Highness's ministers a project for using it as a substitute for that article in the manufacture of fine cordage, and I shewed by experiment that it was fully adequate to the purpose.

We remained two days at Santa Rita and its vicinity, and on the third, set out on our return, taking the same route by which we came. In some parts we observed numerous flocks of birds, particularly parrots, and a few fine wild-hens of the wood, and these were the only objects that engaged our attention. We reached Canta Gallo without having met with any monstrous serpents, or any other uncommon sights which travellers usually see or fancy in a strange country.

After a few days' rest, I set out, accompanied by a guide, to the supposed silver-mine, notice having previously been sent to the men to prepare them for my coming. We travelled for about two miles through a deep valley, and arrived at a rapid stream called Macáca, which runs between two almost perpendicular mountains of very inconsiderable height, along one of which the road leads for about a mile and a half. Having passed this gloomy and dangerous ravine, we proceeded half a league farther, and halted at a neat farm-house called Machada, with a portion of good and well-cultivated land around it, which looked like a garden in the wilderness. The owner, a native of the Azores, received us very politely, and introduced us to his lady, who, with her blooming family of daughters, was engaged in needle-work on materials of their own spinning. The neatness of their dress, and the general air of propriety and comfort in the apartment where they sat, strongly reminded me of my country; and when they regaled us with liquor made from the fruits of their own farm, the image of our domestic scenes in rural life was complete: I could almost have fancied myself transported from the rugged wilds of Brazil to the smiling vales of England.

We left this peaceful abode; and, advancing for six miles through thickets and forests, and over some plain land, we reached a farm called St. Antonio, belonging to a widow named Dona Ana, who is noted throughout the country for making excellent butter and cheese. The dwelling is of two stories, and neat, but very inconvenient. The

good lady gave me a hearty repast of milk, and we entered into some conversation respecting her dairy, in which I learned that she knew no other mode of making butter than that of agitating the cream in a jar or bottle; and her notions of cheese-making were equally defective. In looking about the grounds for an hour, while our mules rested, I noticed an excellent fence, formed by planting a strong thorny shrub, that seemed of very rapid and luxuriant growth. The few cows that were grazing in the inclosures appeared to be of a superior breed, but were not managed with either method or foresight. The principal produce of the farm is Indian corn, and a little cheese; the latter is only made occasionally, when there happens to be a sufficient supply of milk for the purpose.

We were here shewn various samples of earthy matter, wrapped very carefully in paper, and preserved with great secrecy, under the names of platina, silver, &c. They proved to be merely small crystals of brilliant iron ore, and pyrites.

Proceeding a league over a fine country, we reached the Rio Grande, a stream as large as the Derwent at Derby, which we crossed in a canoe, our mules swimming after us as usual. We passed several groupes of Aborigines, and occasionally saw many of their huts and places of abode. The road now led along the bases of some huge bold mountains of granite, from whose summits rushed fine cascades of water. The low ground was interspersed with fragments of the same rock, lying in heaps in every direction. In many places the grass was so tall that it reached above the skirts of my saddle, and, the weather being wet, rendered me very uncomfortable. After a laborious, and latterly a slow progress, we arrived by sun-set at the house of Father Thomas de Nossa Senhora da Concepção, who kindly accommodated us for the night.

The house was new, and neatly built, containing only four rooms, with boarded floors; a convenience very rarely to be met with in these parts. It is absolutely encircled with fine streams, abounding with water-falls, which render the roads to it at all times indifferent,

and in wet weather almost impassable. The father, an intelligent and industrious man, informed me that he took up that land about four years since, that he had only one negro, and had no funds wherewith to carry on his undertaking, except seven or eight pounds per annum, which he gained by his profession as a clergyman; this he expended in hiring those who chose to work. He shewed me his garden, which was full of fine coffee-trees, and was kept in the neatest order; his fields were covered with Indian corn; his live-stock consisted of a good milch cow, a number of pigs, and one mule. On asking him how he disposed of his produce, he told me that dealers came and purchased it on the spot. The whole of the sezmara, or plantation, with the stock upon it, he valued at four hundred pounds sterling, and said that he had no doubt he could obtain that price for it. These were clear data for calculating the profits of farming, when managed with prudence and industry. Here is a man who, having begun with little or nothing, finds himself, at the end of four years, worth four hundred pounds; a snug independency in these parts, and not more than his exertions and perseverance deserved. Father Thomas lived more comfortably than any person I had hitherto met with in the district: he was economical, but not parsimonious; liberal in his sentiments, frank and communicative in his conversation, and polite in his manners.

Here I was met by the discoverers of the reputed silver-mine, who came to conduct me to it. We set out on foot, and, after walking about six miles over mountains impassable for mules, fording rivulets, and passing thickets that left me scarcely a single article of dress untorn, we arrived at the miserable hut of these poor men; a perfect contrast to the neat dwelling of Father Thomas. Never in my life was I so exhausted by fatigue; I lay down, unable to go any further, and rested for about an hour, when, being somewhat recovered, I accompanied the men, along the edge of a beautiful stream, to the foot of the mountain, where they shewed me a hole which they had dug, about two feet deep, and informed me that the

sand it contained at the bottom abounded with grains of silver. Having ordered a quantity to be taken out, I proceeded to examine the base of the mountain, which I found to be of granite-like gneiss, with garnets, and small crystals of pyrites. Near this place the margin of the rivulet contained rounded stones and sand, but no where was there to be found any metallic substance, except the one above-mentioned. Indeed, the very idea of silver appearing here in dust or grains, as gold does, would be preposterous, and contradictory to every principle of nature, as, in such a state, it would probably have been attacked by the sulphur in the pyrites, so as to have assumed the form of a sulphuret.

I returned in a most wearied and exhausted state to Father Thomas's, where, after some needful repose, I proceeded to examine the sand and stones I had collected at the supposed silver-mine, but no particle of metal was to be found. I then ordered the men to produce their samples, which I examined both by the blow-pipe and by acids, but no silver appeared. After equivocating very much, they acknowledged that they had rubbed and beaten substances to powder, and when they found specular iron ore they thought it was silver. In one of the samples there certainly was silver, but it appeared to have been filed probably from an old buckle or spoon, or rubbed on a stone and mixed with a pulverized substance. The farce could no longer be carried on: I charged them, in a most determined manner, with imposture, which, after some hesitation, they confessed: an officer who was with me would have secured them, but I restrained him; for, having obtained a confession, I was unwilling to bring them to punishment, or to render them more miserable than they already were by having them sent to the army. Perhaps that would have been doing them a greater service than setting them at liberty; for they were too lazy to work, and would, no doubt, return to their old habits of prowling about, and subsisting on the credulity of the public by spreading fallacious reports about mines, precious stones, &c. Such impositions are not uncommon in South America: I have known instances in which copper-filings, mixed with earth and after-

wards washed, have been produced as samples, in order to enhance the value of land, or to serve some other sinister purpose. A passion for mining is fatally prevalent among some of the lower orders of the people: by deluding them with prospects of becoming speedily rich, it creates in them a disgust for labour, and entails want and wretchedness upon them. Even among the few families of this district, I observed some examples of its effects; those who devoted themselves wholly to mining were in general badly clothed and worse fed, while those who attended to agriculture alone were well provided with every necessary of life.

Having concluded the affair, I took leave of Father Thomas, and returned to Santa Gallo, where I prepared my papers for a report respecting it, as the Condé de Linhares had desired me. During the remainder of my stay I collected specimens of the different species of wood which the neighbourhood produces. The following is a list of them:

Venatico — excellent timber.

Cedar — good and durable.

Pereiba — hard and good.

Olio — very solid, and of a peculiar fragrance.

Cabiuna.

Jaracanda — cabinet-wood variegated, black and yellow. —

This is called rose-wood in England: but the best sorts, as it appears to me, have not hitherto been imported.

Jaracatang.

Ubatang.

Palms — many varieties, among which is the iri, before described. Its wood is unrivalled for strength and elasticity.

Garfuana — the bark of which, as I was informed, affords a yellow dye.

Embey — a creeping plant. The stems are used instead of cords, and often made into bridles.

Many species of thorny trees.

Most of the above-named species of woods are of large growth, and well calculated for ship-building. It is remarkable that this district produces none of the dye-wood called Brazil wood.

Here are innumerable fruit-trees and shrubs which I have omitted to particularize. Tobacco is cultivated in some parts, and is always manufactured into roll by uniting the leaves with each other, and twisting them with a winch. By this operation the juice is expressed, and, after a short exposure to the atmosphere, the colour of the tobacco changes from green to black.

Of wild animals, ounces are the most common; they are met with of various colours, some black and brown-red. Tapirs or antas are not unfrequent, but I saw only the footsteps of some of them. Wild hogs breed here in great numbers, and also long-bearded monkeys; the latter, when asleep, snore so loud as to astonish the traveller. The most formidable reptiles are the corral snake, the surrocuco, the surrocuco-tinga, and the jararaca, all said to be mortally venomous, none of which I ever saw on the journey, except a small one of the former species.

The prevailing method of clearing and cultivating the land here, is precisely similar to that practised in the neighbourhood of St. Paul's. After the timber and underwood have been cut down and burnt (often very imperfectly), the women negroes dibble the seed; in about six weeks a slight weeding is performed, and then the ground is let alone till harvest. The seed-time begins in October and lasts to November; the maize is ripe in four or five months. The next year they commonly sow beans on the corn land, which they then let lie, and proceed to clear new ground. It is not common to molest the land from which they have had two crops in succession, before eight or ten years have elapsed.

The sugar-cane and mandioca require from fourteen to eighteen months. Coffee planted by shoots bears fruit in two years, and is in perfection in five or six years. Cottons and palma christi, raised from seed, bear the first year.

Transplanting is only practised with tobacco; engrafting is little known and rarely attempted.

The Indian corn is ground by a horizontal water-wheel, which acquires great velocity from the rush of water upon it. On the upper end is fixed the mill-stone, which makes from fifty to sixty revolutions in a minute. They have likewise a mode of pounding the corn into flour, by a machine called a sloth. Near a current of water a large wooden mortar is placed, the pestle of which is mortised into the end of a lever twenty-five or thirty feet long, resting upon a fulcrum at five-eighths of its length. The extremity of the shorter arm of this beam is scooped out, so as to receive a sufficient weight of water to raise the other end, to which appends the pestle, and to discharge itself when it has sunk to a given point. The alternate emptying and filling of this cavity cause the elevation and fall of the pestle, which take place about four times per minute. This contrivance surpasses all others in simplicity, and in a place where the waste of water is of no consequence it completely answers its purpose.

Having finished my affairs at Canta Gallo, I set out on my return to the capital, accompanied for about a league of the road by the worthy governor, the captain, the treasurer, and almost all the inhabitants. During a residence of about fifteen days among these excellent men, my table had been sumptuously supplied without cost, and I had been treated with a degree of respect far exceeding my expectations or merits. I took leave of them with regret, wishing most sincerely that it might be in my power to be of service to them at court, by making representations in their favour.

I arrived at Moro Quemado at night, after a journey of thirty-four miles*, and on the next day, in good time, reached the house

* In one part of the road we passed a nest of insects (called mirabunde) which are extremely troublesome to cattle, and cause the mules to be very violent and unruly. They attack with great pertinacity, and pursue to a considerable distance; we took a devious route to get rid of them, but I was followed by some which stung me as painfully as an irritated wasp could have done. There is a singular variety of them having a horny pointed proboscis, with which they pierce most keenly and give intolerable pain.

of my worthy friend Captain Ferrera. Being now less pressed for time, I took a more leisurely survey of his establishment, particularly of his sugar-work and distillery, both which are very ill conducted. When I saw the furnaces for heating the coppers in the latter, I freely told the Captain, that they could not have been constructed on a worse plan, but I received for answer, that no better was known. It would indeed be extremely difficult to introduce improvements into this or any other parts of the distillery, for every thing is left to the management of the negroes. When I asked any question concerning the process, the owner professed his ignorance of it, and sent for one of the African foremen to answer me. With this man I reasoned respecting the excessive quantity of fuel consumed to no purpose, and proposed a method for saving it, as well as for correcting the disagreeable taste of the rum, caused by the empyreuma, which was, to re-distil it with an equal quantity of water, taking care previously to clean out the still; but he only laughed at me, and signified that his certainly must be the best method, for he had learned it of an old sugar-maker. Thus it is, that from the indifference of the owners to their own interest, things are suffered to go on in the same routine, being left to the direction of men who shrink from a temporary increase of labour, even when it promises them a lasting advantage. This aversion to improvement I have often observed among the inhabitants of Brazil; when, for instance, I have questioned a brick-maker, a sugar-maker, a soap-boiler, or even a miner, his reasons for conducting his concerns in such an imperfect manner, I have been almost invariably referred to a negro for answers to my interrogatories.

Some parts of this estate are said to contain gold, and at the time of my visit, Captain Ferrera was negotiating for permission from Government to work them. I presented to him a drawing of a plan for washing the cascalhão in a manner superior to that commonly practised, and explained to him the use of grinding or stamping those concrete masses frequently found in it, which generally con-

tain particles of gold, but being too hard to be crushed by the hand, are thrown aside among the debris.

In this fazenda, as in most others, the conveniences for storing the produce are so very poor and imperfect that the weevil soon gets into the corn, and the cotton, coffee, and other produce are liable to be deteriorated in a thousand ways. The stabling too is bad, and the cattle are deplorably neglected; indeed the only part of the live stock that seems to be tolerably well attended to, is the swine. In the dwelling-house I observed a total inattention to domestic comfort; its general appearance confirmed a remark which I had often heard made, that the owners of estates here dislike to live upon them, and considering their residence as only temporary, make shift with poor accommodations.

The tract of land belonging to the farm is full two miles square, and though still susceptible of great improvement, has not been wholly neglected; the parts already cleared have produced many valuable crops, and the rest will no doubt in a few years be brought to an equally promising state of cultivation.

Having staid two days with Captain Ferrera, I set out on the morning of the third for Porto dos Caxhes, where I arrived at two o'clock, after a journey of thirty miles, and was delayed some time, as the river was crowded with vessels, laden with ship-timber, for the capital. As soon as the navigation became sufficiently open, I embarked in a large boat, of about ten tons burthen, and rowing all night to the mouth of the river, sailed with a land wind, and arrived at Rio de Janeiro about noon. My first care was to inform His Excellency the Minister of my return, after which I employed two days in drawing up my journal for his inspection. He received it in the handsomest manner, and laid it before His Royal Highness, who was pleased to signify, that my description of the country, through which I had travelled, merited his approbation.

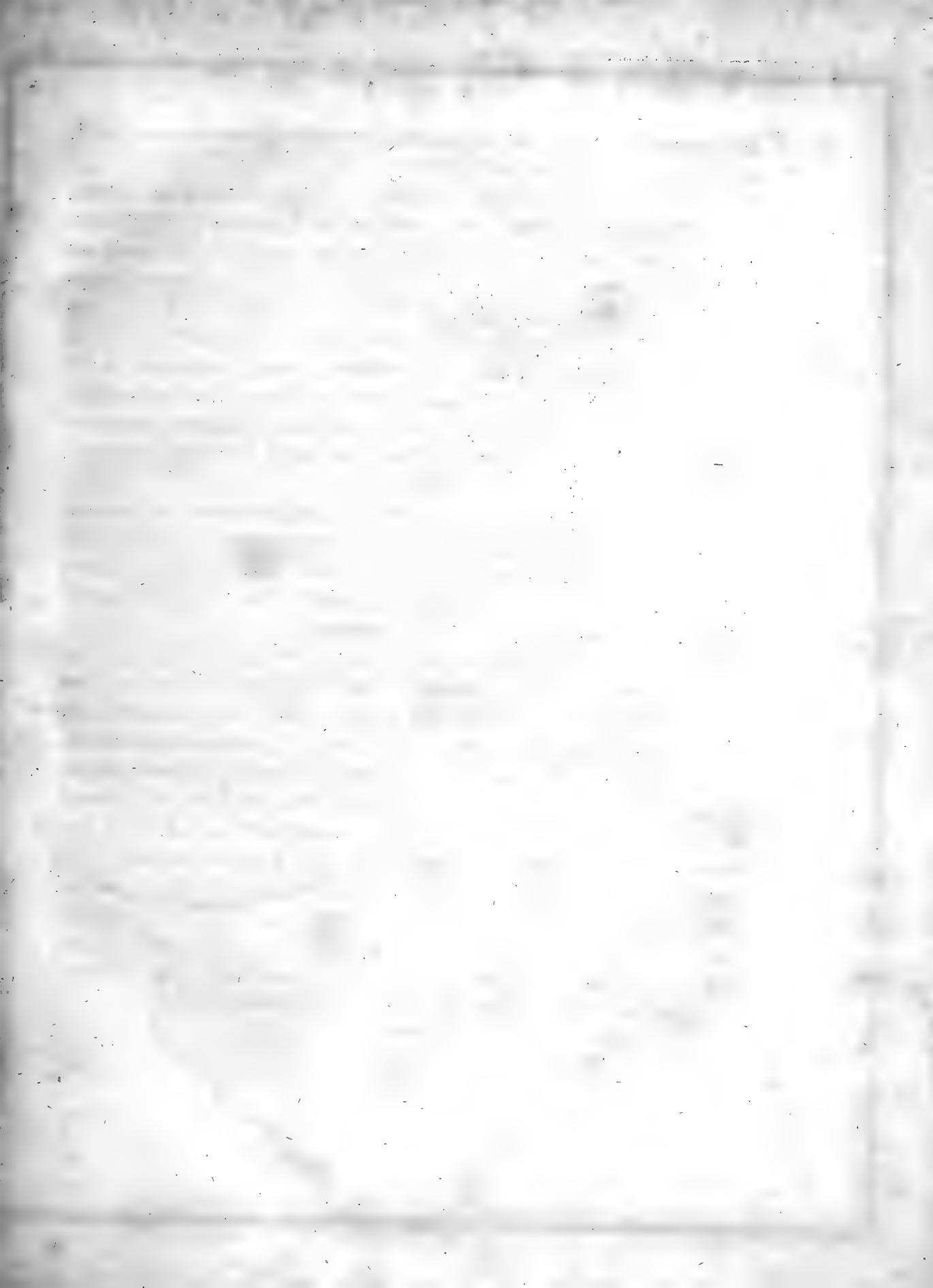

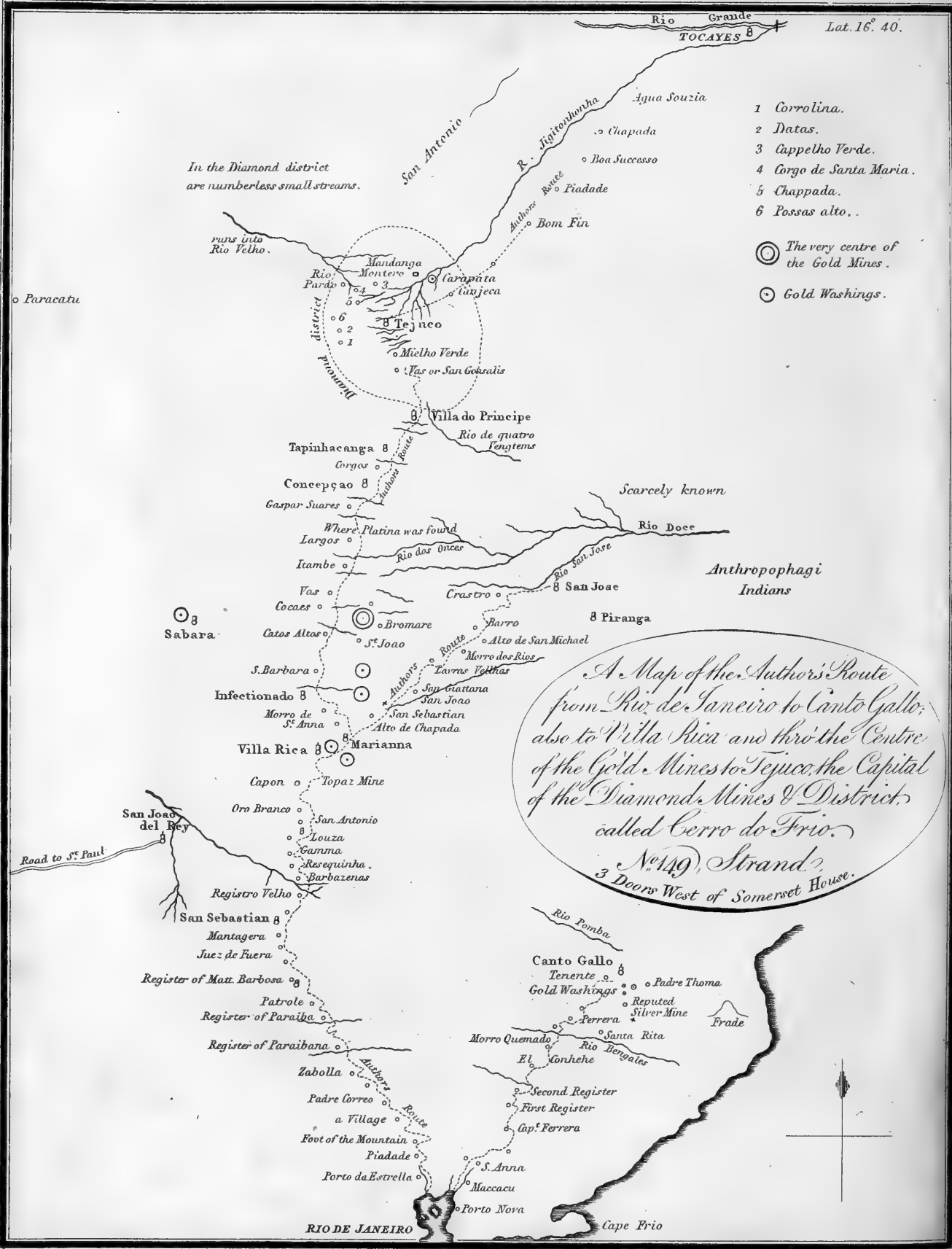

- 1 Corrolina.
 - 2 Datas.
 - 3 Cappelho Verde.
 - 4 Corgo de Santa Maria.
 - 5 Chappada.
 - 6 Possas alto.
- ⊙ The very centre of the Gold Mines.
- Gold Washings.

*A Map of the Author's Route
from Rio de Janeiro to Canto Gallo;
also to Villa Rica and thro' the Centre
of the Gold Mines to Tejuco, the Capital
of the Diamond Mines & District,
called Cerro do Frio.
No. 149, Strand,
3 Doors West of Somerset House.*

CHAP. X.

Permission obtained to visit the Diamond Mines. — Account of a pretended Diamond presented to the Prince Regent. — Journey to Villa Rica.

AFTER I had thoroughly recovered from the fatigues of my late journey, I solicited His Royal Highness for permission to go and explore the diamond mines of Serra do Frio. This favour had never as yet been granted to a foreigner, nor had any Portuguese been permitted to visit the district where the works are situated, except on business relative to them, and even then, under restrictions which rendered it impossible to acquire the means of giving an adequate description of them to the public. Through the kind mediation of the Condé de Linhares, the permission was granted, and my passports and letters of recommendation were speedily made out. Lord Strangford used his influence to further my undertaking, and it was through his goodness in recommending me that I obtained admission to the archives, for the purpose of examining all the manuscript maps, and of copying from any of them whatever might be necessary to guide me in my route. It may here be proper to observe, that the most eligible mode of travelling in the interior of Brazil, especially on such an excursion as I had undertaken, is to procure orders from the government, and an escort of soldiers, who have a right, under such orders, to require proper relays of mules from all persons who reside on or near the road. The Condé de Linhares intimated to me, that I might select any two soldiers I thought proper, and while I was deliberating on the choice, a singular occurrence took place, which was the means of furnishing me with two men of the corps of miners, who were

appointed to attend me, under an injunction on the part of His Excellency that their future promotion would depend entirely on the report which I should give of their conduct after my return. I am happy to say that their services merited every commendation.

The occurrence to which I allude was this:—A free negro of Villa do Principe, about nine hundred miles distant, had the assurance to write a letter to the Prince Regent, announcing that he possessed an amazingly large diamond which he had received from a deceased friend some years ago, and which he begged he might have the honour to present to His Royal Highness in person. As the magnitude which this poor fellow ascribed to his diamond was such as to raise imagination to its highest pitch, an order was immediately dispatched to the commander of Villa do Principe, to send him forthwith to Rio de Janeiro, he was accommodated with a conveyance and escorted by two soldiers. As he passed along the road, all who had heard the report hailed him as already honoured with a cross of the order of St. Bento, and as sure of being rewarded with the pay of a general of brigade. The soldiers also anticipated great promotion; and all persons envied the fortunate negro. At length, after a journey which occupied about twenty-eight days, he arrived at the capital, and was straightway conveyed to the palace. His happiness was now about to be consummated, in a few moments the hopes which he had for so many years indulged would be realized, and he should be exalted from a low and obscure condition to a state of affluence and distinction; such no doubt were the thoughts which agitated him during the moments of suspense. At length he was admitted into the presence; he threw himself at the Prince's feet, and delivered his wonderful gem; His Highness was astonished at its magnitude; a pause ensued; the attendants waited to hear the Prince's opinion, and what he said they seconded. A round diamond nearly a pound in weight filled them all with wonder; some ready calculators reckoned the millions it was worth; others found it difficult to numerate the sum at which it would be valued,

but the general opinion of His Highness's servants was, that the treasury was many millions of crowns the richer. The noise which this occurrence created among the higher circles may be easily conceived; the general topic of remark and wonder was the negro's offering. It was shewn to the ministers, among whom an apprehension, and even a doubt, was expressed that a substance so large and round might not prove a real diamond; they, however, sent it to the treasury under a guard, and it was lodged in the deposit of the jewel-room.

On the next day, the Condé de Linhares sent for me, and related all the circumstances which had come to his knowledge respecting this famous jewel, adding, in a low tone of voice, that he had his doubts about its proving a genuine diamond. His Excellency directed me to attend at his office in a few hours, when letters from himself and the other ministers to the Treasury should be given me *, for permission to see this invaluable gem, in order to determine what it really was. Readily accepting a charge of so interesting a nature, I prepared myself, and attended at the hour appointed, when I received the letters, which I presented at the Treasury to an officer in waiting. I was led through several apartments, in which much business seemed to be transacting, to the grand chamber, where presided the treasurer, attended by his secretaries. Having my letters in his hand, he entered into some conversation with me relative to the subject; I was then shewn through other grand apartments hung with scarlet and gold, and ornamented with figures as large as life, representing justice holding the balance. In the inner room, to which we were conducted, there were several strong chests with three locks each, the keys of which were kept by three different officers, who were all required to be present at the opening. One of these chests being

* No person can be permitted to see the diamonds in the Treasury without a joint order from the ministers to that effect.

unlocked, an elegant little cabinet was taken out, from which the treasurer took the gem, and in great form presented it to me. Its value sunk at the first sight, for before I touched it I was convinced that it was a rounded piece of crystal. It was about an inch and a half in diameter. On examining it, I told the governor it was not a diamond, and to convince him I took a diamond of five or six carats and with it cut a very deep nick in the stone. This was proof positive; a certificate was accordingly made out, stating, that it was an inferior substance of little or no value, which I signed.

Other boxes were now unlocked, from one of which they shewed me two large slabs of diamond, each a full inch on the superficies, and about the eighth of an inch in thickness, of a very bad brown colour. When found, they formed one entire piece, which, being amorphous, was not known to be a diamond, until the administrator or chief of the working party, after keeping it by him many days, had recourse to the old experiment of placing it on a hard stone and striking it with a hammer. The result of this experiment is, that if the substance resist the blow, or separate in laminæ, it must be a diamond; the latter was the case in the present instance, and the man having thus made two diamonds from one, transmitted them to the intendant.

The river Abaité, from whence these pieces came, has produced one of an octaëdral form, which weighs seven-eighths of an ounce Troy, and is perhaps the largest diamond in the world. It was found about twelve years ago by three men who were under sentence of banishment for high crimes; but on presenting this valuable gem to the then Viceroy, they were pardoned and rewarded. It is now in the private possession of the Prince Regent.

I was afterwards favoured with a sight of the remaining diamonds in the Treasury; they appeared to be in quantity about four or five thousand carats. The largest did not generally exceed eight carats, except one of a fine octaëdral form, full seventeen. Among

the few coloured diamonds, one of the smallest was a beautiful pink, one a fine blue, and several of a green tinge; the yellow were the most common and least esteemed.

Having now finished my business, I took my leave of the treasurer, with thanks for his polite attention, and on my return home wrote a letter to the Condé de Linhares, stating the result of my visit. It was no agreeable task for a stranger to have to announce that a substance which had been considered as an inestimable addition to the treasures of the state, was in reality, though singular in its appearance, of very trifling value, and this too in a letter which was to be laid before the Prince. His Highness, however, was prepared for the intelligence, and was too noble-minded to manifest any chagrin at the disappointment. The poor negro who had presented it was of course deeply afflicted by this unwelcome news; instead of being accompanied home by an escort, he had to find his way thither as he could, and would, no doubt, have to encounter the ridicule and contempt of those who had of late congratulated him on his good fortune:

When I had nearly completed my preparations for the journey, Mr. Goodall, a most respectable merchant, expressed a desire to accompany me to Villa Rica, which I readily acceded to, as he was a most agreeable companion. Lord Strangford having procured him passports from the ministers, he was enabled to join me without delay. On the 17th of August 1809, we set out on a journey which no Englishman had ever before undertaken, nor had any ever yet been permitted to pass the barrier of alpine mountains that stretch along the coast.

Having embarked in a large market-boat with our retinue, which consisted of the two soldiers before-mentioned, and my servant, a most trusty negro-boy, we made sail at mid-day with a sea-breeze, and run down the bay about six leagues, where we passed the island of Governador and various others, one of which was the beautiful Cocoa-nut island. Proceeding along the strait, formed by it and

another of similar extent, we crossed a fine open bay, and arrived at the mouth of the Moremim, a picturesque river which presents in its serpentine course a great variety of beautiful scenery. It was now sun-set; the weather was mild and serene, and we paused awhile to enjoy one of the finest rural prospects which we had ever seen in Brazil — a fine romantic fore-ground, enriched by the vivid foliage of the woods on the banks of the stream, and contrasted by the bold outline of the mountains in the distance, among which we noticed that singular chain of perpendicular rocks, called the Organ-pipe mountains, from their resemblance in form and position to the front of the instrument alluded to. Having advanced two leagues up the river we arrived at a village on its margin, called Porto da Estrella, a place of great stir and bustle, on account of the hourly arrival of numerous droves of mules laden with produce from the interior. Here are some poor dwellings, and a number of large storehouses for the reception of the produce. The muleteers, being provided with bedding and cooking utensils, never leave their cattle, so that good inns are to them unnecessary. We were shewn into the best in the place, which was as dirty and inconvenient as can possibly be imagined. I shall forbear to detail the discomforts of the night, and merely observe that they were such as to make us early stirrers in the morning. Our soldiers procured us mules, but owing to the great bustle of loading and unloading, we were not in travelling order until ten o'clock. We now proceeded about three leagues along the low land, having the range of mountains on our left, and passing the village of Piadade entered on a beautiful plain at their base. We stopped at a house at which the Prince Regent had passed three nights for the benefit of the air; but not being able to procure refreshment there, we passed on and began our ascent along an excellent paved road, extending five miles on a very steep elevation along the sides and over the ridges of the mountains. Having rested awhile at the half-way house, which we had been near an hour in gaining, we toiled on, relieving ourselves

at times by turning to take a view of Rio de Janeiro, and the bay, which from this lofty eminence appeared to great advantage. With some difficulty we reached the summit, which, as I supposed, is four thousand feet above the level of the sea ; the atmosphere was at least ten degrees colder than on the plain.

Our next halting place was a small village called Corgo Seco, situated in a most rugged and uneven district, with not half an acre of level ground in any part of its vicinity. Having taken some refreshment here, we proceeded to Belmonte, a beautiful spot, situated by the edge of a rapid stream, which washes the base of an immense mountain of granite on the left. We journeyed along this stream until we reached a station called Padre Correo, from the name of its owner. It consists of a house and chapel, with a handsome area in front. The father maintains a large establishment of negroes, many of whom are employed in beating out mules' shoes from the cool Swedish iron, after they have been forged into form. For these articles there is a considerable demand, as the unwrought material pays no duty on this side the river Paraiba, while on the other it is taxed full 100 per cent., which is also the case with salt. The great consumption of these necessary articles has probably induced Government to lay these heavy duties upon them, but certainly every principle of good policy furnishes an argument against the measure. Padre Correo received us very hospitably, afforded us an asylum for the night, and assisted us in regulating our baggage by supplying a pair of cane panniers for one of the mules, which proved very serviceable. Before sun-rise we were awakened by the clatter of hammers in the forges ; the weather was dewy, and so cold that my thermometer was down at 46°. We passed some time in viewing the garden, which was in tolerable order, and contained some fine peach trees in blossom. Our host informed us, that he had a good plantation a few miles distant, but his chief concern was the selling of corn and shoes for the use of the mules.

Leaving this station we skirted the Piabunha, a river abounding in falls, which flows into the Paraiba. Among the hills and dales which we traversed, we at times observed farm-houses and plantations; but the road, farther on, was quite confined by continual wood-scenery. After proceeding about twenty miles we reached Zabolla, a tolerable establishment, consisting of a house of two stories, a small chapel, and a sugar-engine, in an unfinished state, situated in the bottom of a valley. The owner, Captain José Antonio Barbosa, was a Portuguese of the old school; he seemed much vexed that His Royal Highness had permitted strangers to travel the country, and treated us with a constrained civility which shewed that he thought we were come about no good. His conversation ran continually against the operations of Government in laying taxes upon rum and other commodities; and though he tasted the sweets of office, being part-renter of the lucrative ferry of Paraiba, which post he obtained through the interest of a very worthy gentleman in Rio de Janeiro, yet he had all the acerbity of a disappointed place-hunter. His self-interested and narrow-minded views were but too plainly directed to one object, monopoly; the mere mention of the Prince Regent's liberality in permitting strangers to reside in Brazil appeared to torture him, and in short, so much of the snarler did he display while discussing this topic, that no character could have more forcibly reminded us of the dog in the manger. It is, however, but fair to add, that while indulging in severe reflections on strangers, he did not forget the duties of hospitality: before we went to rest, he invited us to partake of a family supper, consisting of a boiled duck smothered in rice, and a stewed pullet, to which sat down eight people, including ourselves. Having thanked our host for his kindness, we retired to the apartments allotted to us. My bed was so uneasy that I was obliged to sit up during most of the night, having no alternative, for as the clay floor was neither boarded nor paved, I could not venture to throw the bed-clothes

upon it, and sleep there. Never did mortal hail day-break with greater satisfaction ; but my agreeable feelings were soon damped by one of those little vexatious accidents which in some states of mind are more hard to bear than real misfortunes. I had placed my thermometer in a *wind-door* or air-hole (for the aperture was not glazed) ; a stupid fellow, in fastening the bridle of a mule to one of the bars, threw down the instrument and broke it. Luckily I had another, therefore the loss was not so grievous.

Our soldiers having, with their wonted alacrity, provided mules, we set out at an early hour, and entered upon a much more level road than that of the preceding day. We passed along several valleys, the surface of which presented clay and decomposed granite, in some places more ferruginous than in others. There are numerous sheds all the way for the refreshment of travellers and their cattle. This day's journey being only sixteen miles, we soon completed it, arriving about noon at the ferry of Paraibuna. This river, though as wide as the Thames at Westminster, is unnavigable, by reason of the large rocks which impede its course. The ferry-boat arriving, we got into it with all our mules, and were conveyed with oars and setting poles to the other side, where we found a register for the examination of passengers, their passports, and property. The place is guarded by a few old soldiers, under the command of a lieutenant, who, though in ill health, shewed us every attention. Our soldiers got us a dinner cooked at a *vend**, kept by a young man originally from Oporto ; we took tea and supped with the commandant, who assigned to us an apartment in the Register. He

* This name is given to what we should call a huckster's shop, where various articles, such as liquors, Indian corn, and sometimes sugar, are sold. Though they profess to answer the purpose of inns, they are destitute of conveniences ; travellers who carry their beds and cooking utensils with them, generally prefer lodging in a rancho or astallage. Shelter from rain and night air is the only convenience which a lodging in these districts can be expected to afford.

was very civil, and seemed highly pleased to see us, frequently exclaiming, "Os Ingleses son grande gente," (the English are a great nation). We were gratified by this and other national compliments which he paid us, and not less so by the respect which every one who came to visit us testified for our country, as being in alliance with a Prince to whom they were enthusiastically devoted.

The Register is a substantial edifice of wood, built on posts to preserve it from the overflows of the river, which frequently inundate the sandy flat on which it stands. It contains a few rooms, which serve as barracks for the guards, and has a handsome gallery fronting the ferry. The station is low, and in summer is said to be very hot and unhealthy; a circumstance which, joined to the indolence and poverty of the inhabitants, may sufficiently account for the general appearance of debility observable among them. The little employment they have arises chiefly from the passengers who frequent this great thoroughfare, and from the numerous troops of mules which are continually arriving on their way to, as well as from, the interior. The barges of the ferry are as fine vessels as any I ever saw used for the purpose; and indeed they ought to be, for a considerable toll is paid, not only for every mule, or other beast of burden, but for every person crossing the river. The annual amount collected yields, no doubt, a handsome profit to the renters; but it might be considerably augmented if a regular road were opened to Canta Gallo, which is only eighteen leagues distant.

Being informed that our next day's journey would be an arduous one, on account of the hilly district through which we should have to pass, we retired to rest betimes, and were stirring at an early hour. We mounted fresh mules, and proceeded along a good road through a rugged and thinly peopled district; in the course of five leagues, we passed over seven very high granite mountains, and eight smaller ones, and at length reached the ferry of the Paraiba, a river considerably larger than the Paraibuna. At the Register belonging to it, which is more extensive and better guarded than the former,

all goods are examined and weighed, paying duty according to their weight, whatever be their kind, quality, or value. This regulation bears very unequally upon different articles ; salt, for instance, pays nearly cent. per cent. iron and lead about the same ; while woollens, cottons, and other light goods do not, on an average, exceed eight or ten per cent.

The commandant of the Register offered us every assistance, and was kind enough to provide us a fresh mule for our baggage. The short time we staid here did not allow much leisure for observation ; and, indeed, there was little of novelty to observe. The situation of the Register is pleasant ; the country around is well wooded and fertile, though mountainous. The river is almost destitute of fish.

We proceeded about a league and a half further, through thick woods, and arrived at a place named Rosina de Negra, where we halted for the night. Our next day's journey presented the same varieties of hill and ravine as those we had already passed. In one part of the road we observed a kind of barracks, consisting of an astallage and some ranchos or huts, where an officer and about twenty horse-soldiers are stationed ; they patrol the road, and are authorised to stop travellers, and make the strictest search of those whom they suspect of having gold-dust or diamonds concealed. Proceeding two leagues, we arrived at the Register of Matthias Barbosa, situated in the midst of an almost impervious wood. It was built about sixty or seventy years ago, by the gentleman whose name it bears, and who was an ancestor of the noble family of Sousa.

This register is a large oblong building, with two great doors at each end, through which all travellers, with their mules, are required to pass. On entering, they stop, and deliver their passports to a soldier for examination by the commander, who, if he judges that a correct account is given of the property, suffers them to proceed : but if any grounds of suspicion occur, the mules are unloaded, and

all the contents of their cargoes are examined with the strictest scrutiny. In these examinations it not unfrequently happens that a negro has been suspected of swallowing a diamond; in which case, he is shut up in a bare room until such time as the truth can be proved. The command of this station is entrusted to a major. The inner part of the building consists of apartments for the officers, ranchos for the soldiers, cells for the confinement of suspected persons, and stabling for the mules. In the yard there are numerous posts, to which the cattle are tied while loading or unloading. There is also a vend for the accommodation of travellers.

Leaving this place, we proceeded through an extensive tract of wood, in which we occasionally observed a few deer, but no birds, except now and then a green parrot or a wood-pecker. The road, as far as the eye could reach, was bounded on each hand by close continuous thickets, and rarely enlivened by traces of habitation. Those persons who live by the way-side are commonly of the lowest order of people, who settle there with the view of selling refreshments to travellers, and corn for the mules; they are in general an idle, gossiping race: the more respectable classes reside at a distance from the public road.

We arrived about four in the evening at a farm-house called Madeiras, belonging to Captain José Pinto de Souza. The situation is cold and salubrious, the vicinity well-watered, and abounding in fine tracts of arable and pasture land, but deplorably neglected. The owner seemed to prefer ease, with inconvenience, to labour, with comfort; and, satisfied with the spontaneous bounty of nature, cared little about improving it by industry. The house itself was miserably out of repair: its walls, which consisted of lattice-work plastered with clay, were full of holes and crevices, and its roof was in a very crazy and shattered condition. We fared but poorly, and passed a very indifferent night; often reflecting on the apathy and listless indolence of the people: who, thought we, in a cold climate would live

in a dwelling full of cracks and air-holes, when a few dashes of mud might render it comparatively comfortable !

From this place, which is an hundred miles from Porto da Estrella, we continued our route next day over a chain of mountains, among which we encountered other falls of the Paraiba nearer its source, and, traversing a tract of close wood-land, arrived at a station called the Fazenda do Juez de Fuera. Here we procured fresh mules, and proceeded for a considerable distance on the ascent, when we met with two planters from Minas Novas, who were going to Rio de Janeiro with forty-six mules loaded with cotton, packed in raw hides, each beast carrying two packages. They had been nearly three months on the road. We availed ourselves of their kind offers to carry intelligence to our friends in the capital, and gave them letters for that purpose.

The remainder of our day's journey afforded few incidents worth notice. We observed several pines of a singular species, which yielded abundance of resin. In one part of the road I shot a most beautiful bird, the name of which I could not learn, but was informed that it flew about much in the night. In another part, we noticed a beast of prey, which was crossing the road before us, and fled at our approach. I killed a small water-snake, with two fins near its vent.

We arrived towards evening at the Fazenda of Antonio Ferrera, formerly a good house, but now almost in ruins. The owner was not at home ; but his old negro-servants provided as handsomely for us as we could have expected them to do if he had been present. We made a tolerable supper of stewed fowls, with the addition of a fine wild turkey, which I had killed in the vicinity. I may here observe that a traveller in this country should neglect no opportunity of providing for himself with his gun, as he is never certain of palatable fare at the places where he alights.

The surface of the country is in general good strong clay ; all the rocks are of primitive granite, in the composition of which hornblende predominates. We this day passed the site of the first gold-washing, which is very small, and has been many years abandoned. The

rivulets have a great deal of oxide of iron in small grains mixed with the sand in their eddies. In some places the granite is in a decomposing state, and there are large nodules of what the Germans call grünstein, which appear not unlike basalt. The air in these elevated districts is fresh and cool, except from two to four o'clock in the afternoon, when I found it rather hot. In the evening, while amusing ourselves with shooting, we observed a man in a friar's habit, with a box bearing a picture of the Virgin, fastened to his waist by a belt. His face was overgrown with hair, and his whole appearance exceedingly wild and uncouth. On inquiry, we were informed that this extraordinary figure was a hermit; and that he had embraced this austere way of life by way of doing penance for some great crime.

Having pursued our diversion while day-light lasted, we returned to the house, where, for the first time since our departure from Rio, we partook of a comfortable meal, and regaled ourselves with a bottle of excellent madeira, which my worthy companion by good fortune had brought with him.

We set out next day by sun-rise, and proceeded some miles along a tolerable road. The vallies as we advanced were wider, and more easy of cultivation, but the mountains were excessively steep. On even ground our general pace was three or four miles an hour, but on the acclivities we proceeded slowly, and were obliged to observe every step of our mules, and to balance ourselves accordingly. This action of the body produces no perceptible consequences for the first few days, but afterwards it begins to torture the loins with a species of lumbago.

After a journey of twenty-eight miles, which occupied nine hours, we found ourselves at six in the evening at a small farm-house called Fazenda de Doña Clara and Doña Maria. These two good ladies honoured us with a more polite reception than we had hitherto experienced on the journey. It being the festival of St. Bartholomew, a great holiday among the Brazilians, they had prepared a more sumptuous dinner than usual, of which they kindly invited us to par-

take. We were the more sensible of this act of hospitality, because it evidently proceeded from sincere good-will ; and, like the widow's mite, derived additional merit from the smallness of the store which supplied the means of performing it. Their establishment seemed barely provided with necessaries ; and the house in which they lived was ill built and scantily furnished. We could not but smile at the earnestness with which one of these worthy ladies complained of the hardness of the times ; they paid, she observed, a *moidore* every three years in taxes. How happy, thought we, would our English spinsters of slender incomes deem themselves in being so lightly assessed !

We passed the evening tolerably, having provided ourselves with candles, which we found very necessary both here and in other places on the road ; for the rooms in general are lighted only by a glimmering lamp, which rather augments than diminishes their melancholy gloom.

In the morning we were informed that the mules which had been provided for us over-night were taken away from the stable. This so enraged our soldier, that he immediately rode in quest of them, brought them back, and pressed others for our service. We here saw the convenience of travelling under official orders : had we not been so provided, we might have been exposed to a most vexatious delay. These military requisitions of cattle may be considered by the owner as a grievance ; but he generally indemnifies himself by high charges to other travellers, and by impositions in the way of trade.

Being now within the province of Minas Geraes, (a country famed at Rio de Janeiro for its excellent cheese,) I expected to see some improvement in the condition of the country, — some establishment worthy of being called a farm, — some dwelling, constructed not merely for shelter but for comfort. I hoped to remark among the inhabitants that air of health and animation which springs from the invigorating occupations and cheering pursuits of husbandry ; but no such pleasing change was perceptible : the same want of exertion prevailed here as in other parts of the country : the people seemed

to act as if the tenure by which they held their lands was about to be abolished ; all around them had the appearance of *make-shift* : their old houses, fast hastening to decay, bore no marks of repair about them : wherever a bit of garden-ground was inclosed, it appeared over-run with weeds ; where coffee-trees, planted in former years, still existed, the present occupiers were too indolent to gather the fruit : no inclosures were made for pasturage ; a few goats supplied the little milk that was consumed ; and cows'-milk was rarely to be procured. On observing these deplorable consequences of the apathy of the inhabitants, I could not but reflect on the advantages which might accrue from the introduction of the English system of agriculture among them. The example of a single farm, conducted on that system, might go far towards rousing the people from their slothful state ; and, when they once felt their faculties awakened, they would be ashamed to lounge about as they now do, under an old great coat, for days together, burthens to themselves, and objects of contempt to all strangers who see them.

The next place we visited, after quitting the residence of these old ladies, offered every requisite for making the experiment above alluded to. It was a fazenda called Mantegera, situated in the largest plain we had hitherto traversed, consisting of rich land watered by numerous streams. The establishment was in a fit state to begin with : the house was falling to ruin, and the grounds about it were over-run with weeds and brush-wood. What more desirable situation, exclaimed I to my companion, could an English farmer select ! Here cattle of every description are cheap ; cows and oxen at two years old may be purchased at 30s. or 40s. per head ; excellent horses from 60s. to 8l. each ; and pigs, poultry, and other live-stock, at a price too trifling to mention. Here is land which, under the influence of this genial climate, is capable of yielding two-hundred-fold ; here is wood in abundance for every purpose ; excellent clay for making bricks ; and water at command. Yet all these advantages are lost to the present occupiers, who consider them too cheap to be valuable ;

and, perpetually hankering after the precious minerals, seem to think that the only standard for estimating the gifts of nature, is the difficulty of obtaining them.

Having passed the hamlet of St. Sebastian's, we arrived late in the evening at Bordo do Campo, a village consisting of about twenty houses, the best of which is that of Captain Rodrigo de Lima, who, on learning our situation, kindly took us in for the night. While supper was preparing, we had some conversation with him respecting the agriculture and produce of the neighbourhood, in the course of which he paid much attention to our observations, and promised next day to shew us the system he pursued. At the repast, which was speedily announced, he introduced us to his wife and daughter, and a lady who was then on a visit to them. This was an unexpected act of politeness, and one which had never yet been exercised towards us by any master of a family in the whole course of our journey. The few females we occasionally saw at any former place generally secluded themselves on our arrival and during our stay; and, when they came near us by chance, they commonly ran away in as much apparent alarm as if they had been accustomed to be frightened at the name of an Englishman. The ladies appeared in very neat dresses of English manufacture, with a profusion of gold chains about their necks, which are always worn on receiving or paying visits. Their conversation was gay and enlivening; they were very inquisitive respecting the costume of English women, and seemed quite astonished at hearing that they wore caps, it being never the custom among the Brazilian females to cover their heads until advanced in years. They ornament their hair with combs, frequently of gold, and very richly wrought. Wine was introduced, of which the ladies could not be prevailed on to partake: they gave our healths by putting the glass to their lips. After supper, the table was covered with delicious sweet-meats; when, being desirous of paying the lady of the house a compliment, I spoke highly of their excellence, and presumed that the fruits were preserved under her immediate direction: but she as-

sured me to the contrary, and observed that her negra did all that sort of domestic work. I perceived, or imagined, that she was rather offended at my remark, and therefore apologized by saying, that it was not uncommon for the ladies in England to interest themselves personally in the concerns of housewifery. The remainder of the evening passed off very agreeably.

On looking out of my chamber-window the following morning, I was surprised to see two small and very neat inclosures, in one of which flax was growing, and in the other wheat. The latter, which apparently had been sown about seven weeks, was very poor and unpromising: the ground had too much water, and seemed of late to have been flooded. Our host regaled us with a breakfast of stewed fowl, excellent coffee and milk, and a dish of feijones, with mandioca and buttered toast; after which he conducted us to his inclosures.

The flax was very healthful and strong: he told us he cut* it three or four times a year, and that it was dressed, spun, and woven in his own house. He grew but little, having occasion for no more than what answered his domestic purposes. The wheat, he told us, was blighted. He shewed us a sample of last year's growth, which was very poor, coarse, and foul. The mills are of similar construction to those used at Canta Gallo, but I did not observe a pair of stones fit for the grinding of wheat.

I now expressed a wish to see his dairy, which the good gentleman immediately complied with. Instead of an apartment, such as I expected to find, fitted up and kept in order for that sole purpose, I was shewn into a kind of dirty store-room, the smell of which was intolerable. The present, I was told, was not the time for making cheese, as the cows gave milk only in the rainy season. I begged to see the implements used in the process; and on examining them

* In this country the practice of cutting flax is attended with great success, and is preferred to that of pulling it, which prevails elsewhere. The fibres, though cut, are considered sufficiently long to be spun and made into good common linen. The old roots produce fresh shoots incredibly soon.

found, to my utter astonishment, that neither the vats nor cloths had been washed since they were last used, and the milk-pails, &c. were in the same condition. This sufficiently accounted for the offensive smell which I had perceived on entering the place. When I asked to see the utensil used for making butter, an apology was made by stating that it was not in the way: they had observed my disgust at the other vessels, and probably thought that this was equally unfit to be inspected. I did all in my power to inform our worthy host of the manner in which English dairies were conducted, and gave him several directions which he wrote down, but seemed quite indifferent about adopting them. On enquiry, I found that no provision was made for the cows; there were no houses erected for milking, and that operation was frequently neglected, and at all times badly performed.

The premises bore traces of the industry and taste of the former occupants: there was a mud-wall round them, encompassing about an acre of ground, which, when perfect, must have given the whole a retired and comfortable appearance; but it was now partly broken down and in ruins. The steps leading to the front door of the dwelling were of the lapis ollaris, or pot-stone, of which substance there is a stratum in the vicinity.

Our cattle being ready, we mounted about eleven in the forenoon, returning thanks to our host, and offering to pay for the accommodations we had met with; but the only compensation he required was a promise on our part to pass a day or two with him on our return. The ladies, who had not appeared at breakfast, came out upon the gallery, and very pleasingly and politely wished us a good journey.

Resuming our route, we passed several small farms, and observed that the blight had destroyed all their bananas, and withered their coffee-trees. My thermometer at the time was not lower than 52° , but the damage had been done some days before by a sharp southerly wind. In some parts of the road there were very small inclosures of flax and rye. The country now appeared more open, and the wood-scenery

lay at a greater distance. We rode by the side of a barren mountain, which was covered to an extent of three miles with quartz, and produced little or no herbage, except a species of wiry or windgrass, which was much parched by the sun. We descended a declivity tremendously steep, and full a mile in length, at the bottom of which we crossed the Rio das Mortes, here a small rivulet. On its further bank is an astallage, or inn, called Registro Velho, (Old Register) being originally built as a searching-office, to prevent the smuggling of gold. Proceeding hence, the eye is again relieved from confined wood-scenery by the prospect of a grand amphitheatre of mountains, which are bounded by others of amazing magnitude, covered with forests. On the side of one hill, which we skirted obliquely, I observed several crystallized masses, which, on examination, proved to be clusters of cubes of ferruginous quartz of a dark-brown colour. We shortly afterwards arrived at a village called Barbasinas, situated on a commanding eminence, in a most fertile country, and apparently containing about two hundred dwelling-houses. While we stopped to take some refreshment, numbers of the inhabitants came to look at us, having never before seen Englishmen, and being on the rack of curiosity to know the objects of our journey. At this place two great roads from the mining country unite, and form the main road to Rio de Janeiro. That to the westward leads from St. João del Rey, Sabara, and Cuiabá; the other from Villa Rica, Mariana, Villa do Principe, Tejuco, Minas Novas, &c. Being a sort of half-way station to the capital, and the last open place on the road, it is much frequented by people from various parts of the interior, and has a considerable traffic in various articles, particularly baizes, cotton goods, salt, and iron. Many of the shops were well stocked with English manufactures. The place is governed by an Ouvidor, or justice of the peace, and a military officer. In its neighbourhood there is a quarry of soft, whitish granite, from which mill-stones are made; but, from the specimens I saw of it, the material must be very unfit for such a purpose.

We arrived, about four in the evening, at a poor place called Resequinha, the owner of which made every provision for us which his scanty means afforded. He dispatched a negro to gather grass for the mules, which is here incredibly scarce; and killed us a fowl or two for dinner. The time previous to that meal hung heavy on our hands; there were no birds to afford us an hour's shooting, and we had no source of diversion, except that which the lively fancy and inexhaustible humour of my companion afforded. We dined heartily about seven o'clock on stewed fowls and mandioca, which fully supplied the want of bread. That article is so extremely scarce in these parts, that even the populous village of Barbasinas, though situated in the richest corn-district of the province, could furnish us only one rusk. Being overcome with weariness, we prepared for rest. One of our beds was placed on the table, the other on a dried hide stretched upon the clay floor. These were miserable accommodations; but sleep knows little distinction between the hovel and the palace, and a man thoroughly disposed may enjoy it as soundly in one as in the other. So it was with my companion; he was in a profound slumber within five minutes after he had lain down, in despite of the rough materials of which his pallet was composed. Mine prevented me from sleeping, and compelled me to sit up during most of the night; it consisted, as well as his, of the leaves of Indian corn crammed into a bag, with the mouth tied up; but the careless negro who performed that operation had neglected to pick out the core or pith from which the grain is rubbed so that there was no finding an easy posture upon it. I sat musing on the absolute wretchedness of every thing around; a miserable lamp hung over our heads and threw a dismal glimmer through the apartment; the floor was uneven and broken into holes; the table on which we had dined consisted of one large plank of a quality not discoverable without the assistance of a scraper, as it had never been cleaned since it was made; there was not a chair or any thing resembling a seat, except an antique bench with a back

to it, fixed at a distance on one side of the table, so that some of the guests had to take their repast standing. The very beasts in the out-houses were better provided for than the master, if we might judge from the healthy condition of those we saw, whose slothful apathy could be matched only with that of the swine they fed.

We left Resequinha an hour after day-break, and entered on some clayey ground which caused our mules to come down frequently, as they were unshod. The day being Sunday we found some difficulty in procuring fresh mules, as they were all engaged in taking their masters to mass. After proceeding about a league and a half we arrived at the fazenda de Gama, consisting of a good mansion and some out-buildings. The house, which is the residence of a major, stands on an eminence in a fine open country, beautifully interspersed with clumps of trees and small patches of wood, but wholly uncultivated and destitute of inclosures. The land appeared much burnt up, and ill supplied with water, but the valleys, we were told, abounded in numerous streams and rivulets. Having stopped at the door we were saluted by the voice of a fine motherly-looking lady apparently about forty, who invited us to alight, which we readily obeyed, having occasion to change our baggage mule. Two young ladies, the daughters of the one whom we had first seen, came on the gallery to welcome us. As the morning was cool, they were covered with purple mantles of baize which left only a part of the face exposed, but shewed us sufficient to prove that the females of this province, here called mineras, are above mediocrity in personal charms. This opinion was confirmed on entering the house, where these ladies appeared to much greater advantage; they were in the bloom of health, rather tall in stature, and in their air and gestures extremely graceful. We had just entered into conversation when in came our soldier to announce that the baggage mule was loaded, and that the day was so far spent as barely to allow time enough to reach the next station before night. This honest fellow for the first time on our journey was the bearer of unwelcome news. I asked

him why he did not bring us to this mansion last night, instead of halting at the miserable dog-hole of Resequinha. " Ah Sir," replied he, " the mules could travel no further." " Then you might have told us of this delightful place and we would have walked hither had it been double the distance." How much more merrily should we have passed the evening, thought I, on observing two fine guitars hung up in a closet that was accidentally opened. The mother, who now came in, gave us an invitation to stop, regretting that her husband, being confined by illness to his bed, was unable to pay his respects to us in person. We expressed our disappointment at not being able to avail ourselves of this invitation, and again related how ill we had passed the night at Resequinha. " Yes," observed one of the daughters very facetiously, " men alone make very insipid society; you would have been much better here, would not you?" Our soldier again came to say that the baggage mule was out of sight, and that we should be in danger of losing our way. The mule, said I, may surely for once fall lame to accommodate us, or some lucky misfortune may occur to give us a pretext for prolonging our stay. We were at length obliged to yield to the pressing remonstrances of our soldier, and took leave of the good lady and her amiable daughters, promising to visit them on our return. We pursued our journey, with reluctance, over a dreary tract of country, passing at intervals through small woods, where we shot a few woodpeckers, here called carpinteros, a name sufficiently characteristic of their peculiar habits. The incessant hacking which they make with their beaks may be heard at considerable distance. No incident worth mentioning occurred in this day's journey, which terminated at Bandera de Coelho, where we arrived at sun-set. A more dirty and slovenly place, in a finer situation, we never visited. It was with great difficulty that my negro-boy procured us a pot of any sort to dress us a fowl and some beans for supper. The kitchen was a mere dirt-hole, blackened with soot and smoke above and all around, and covered with mud and filth below: the

cooking utensil was a pot placed on three stones and heated by a fire of green wood. The owner was very assiduous in helping us, and heartily desired us to make free. He was reputed to be a man of considerable property, which he had accumulated by selling corn for the troops of mules which frequently stop here, and are generally better accommodated than his biped guests. We procured something in the form of a supper, and passed the night under the same sort of shed as that which sheltered our cattle, and on bedding very little superior in quality to theirs.

The experience of this night completed the catalogue of inconveniences to which we had been exposed since the commencement of our journey. I would advise every traveller who pursues the same route, to provide himself with bed and blankets, a stock of tea, sugar, candles, liquors, soap, and salt, two kettles and a drinking-horn (for in few places will he meet with any of these articles), as well as an umbrella, which can by no means be dispensed with. The whole of this equipage is necessary for each person who travels to make observations on the country, and will require at least two baggage mules to carry it.

We set out next morning at six, without breakfast, not being able to procure either coffee or milk; and proceeding six miles through a fine open country, arrived at a large village called Louza, containing full two thousand inhabitants. It is well built, but as I was informed, has much declined from its former consequence, which it owed principally to the rich mines in its vicinity now almost exhausted. We procured a tolerable breakfast of coffee and eggs at a vend; and, while we partook of it, were much amused by the numbers of inhabitants, who crowded the door in eager curiosity to see us, asking a variety of questions of a political nature, and forming endless conjectures respecting the object of our journey.

Leaving this village about eleven o'clock, we proceeded along a range of mountains composed of argillaceous schistus, and passed a hill covered with micaceous iron ore; in one part of it there was a

break that shewed the stratum (which appeared perpendicular) of ferruginous matter, or probably it was a strong vein which traversed the mountain. I was not a little surprised to find that the road, for above half a mile, was covered with rich iron-ore.

We passed a place called Alto de Virginia, where, as well as in the vicinity, to a considerable extent, there are gold-washings, which bear the general name of Labras de Virginia. I examined the heaps of debris, but found in them nothing but rounded quartz and ferruginous matter. Journeying half a league further, we came to the gold-washings of St. Antonio de Oro Branco, where hillocks of the same materials abounded; and we soon afterwards entered the poor and almost deserted village of the same name, containing about five hundred souls. We had an interview with the commandant, but could obtain nothing in the way of refreshment; indeed the few people we saw were so needy, that far from being able to supply our wants, they seemed to crave all we had to satisfy their own, and eyed us as if they expected we had brought them something. Glad to get away from this wretched place, we continued our journey through a succession of fine valleys, and arrived about four o'clock at the foot of a tremendous mountain, overhung with clouds. The ascent was so steep that, judging it in vain to attempt to ride, I dismounted; our soldier, who was a lighter man than myself, exchanged mules with me, and up we went in a zig-zag direction for half an hour, when we found ourselves immersed in a thick cloud, which for some time hindered us from seeing our way. We were at length able to proceed, and in many parts had to mount up ledges nearly two feet perpendicular, which we performed without alighting, as our saddles were secured from slipping off behind by a strong strap passing round the mule's neck. It is considered very unsafe to dismount in these ascents, for the animals go much less steady when led than when ridden. At seven o'clock we reached the summit, where, though night was setting in, we found it necessary to rest half an hour, and then proceeded a league in the dark without our baggage

mule, which, being unable to keep pace with us, had been left in charge of two of our men and the negro-boy. We were under little apprehension for the safety of our property, though, as we afterwards learnt, the poor animal was down above twenty times in the course of the ascent. About eight o'clock we reached Alto do Moro, our baggage arriving about an hour after. Here we halted for the night in one of the best inns we had hitherto seen, the hostess of which soon provided us with a comfortable supper, of which we partook very heartily and passed an agreeable evening. The good order and propriety which reigned in this inn confirmed an observation we had often made, that of all houses on the road those under the direction of females were managed with most ability, and certainly afforded the best accommodations. I may add, that there prevailed in them that evident disposition and wish to oblige which generally makes up for any deficiency, and by appealing to a stranger's liberality makes him satisfied with whatever is set before him.

The land, through which we this day passed, appeared much burnt up, being in general very bare of vegetable soil, and having few trees to defend it against the heat of the sun. In the mountains we observed several slips or breaks which presented abrupt and singular masses lying in all directions like confused heaps of architectural ruins, disclosing veins of soft talc, and some *casalhão* poor in gold. The stratum was argillaceous schistus, very ferruginous, and friable. At the bottom of these slips, which appeared to be caused by the disrapture of one part of the mountain from the other (probably through the infiltration of water), there were small streams which in rainy weather swell into torrents, and burst through their channels with great velocity.

The next day, it being our intention to reach Villa Rica before night, we set out at an early hour, notwithstanding the cold cloudy weather and the heavy dew which prevailed. We passed through a bare and uneven tract of country, presenting similar characteristics to

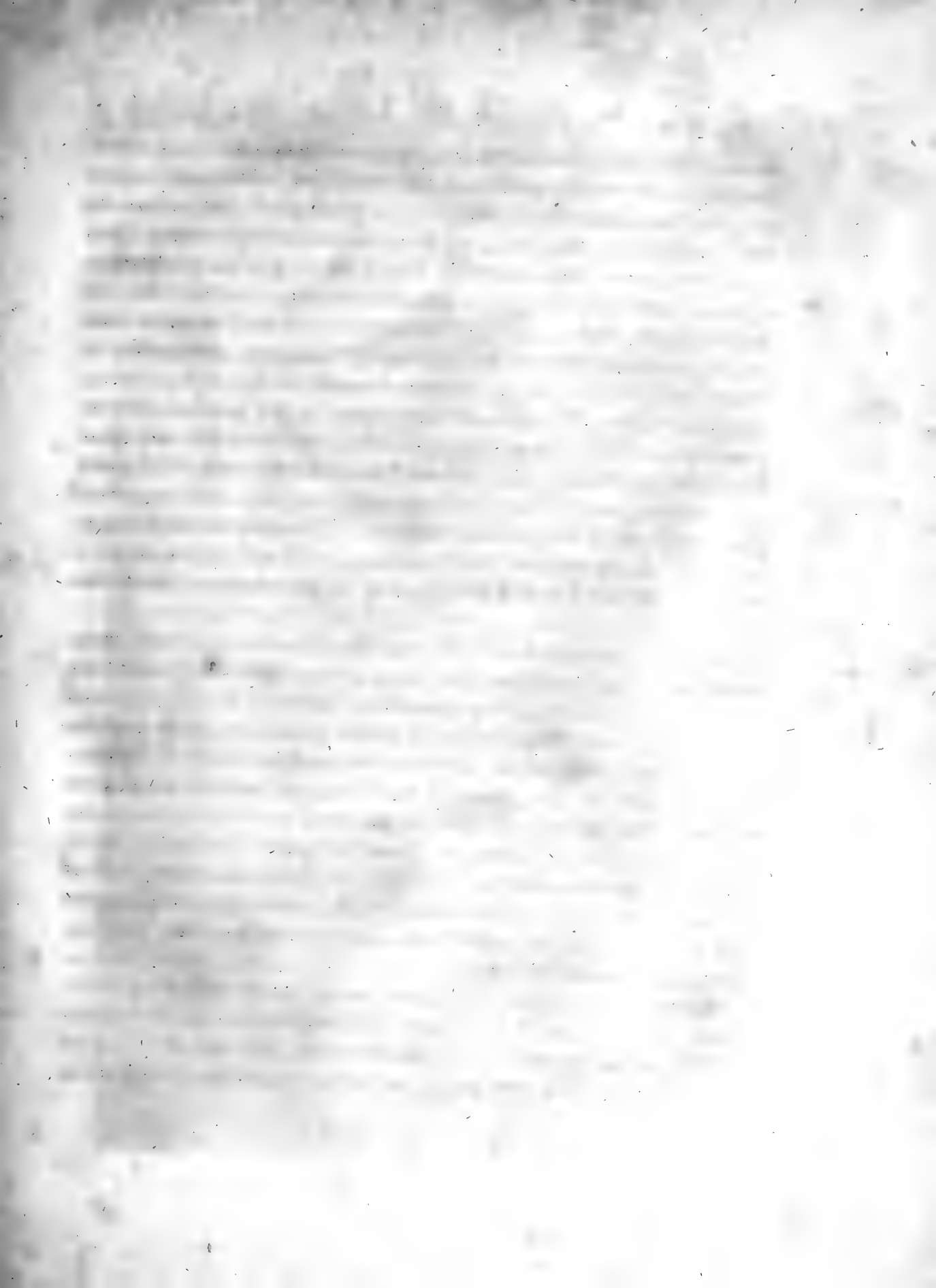



Drawn by M. Lowry, from a sketch by M. Mawe.

W. Woolcuth, Sc.

View of a Topaz mine at Capon near Villa Rica.

those above described. Near a place called Capón, I rode down a hill covered with rich iron ore in such profusion that tons might have been gathered from the surface. Proceeding a short distance farther we arrived at a house, the owner of which, we afterwards understood, possessed a topaz-mine in the neighbourhood. The mention of a *mine* of topazes excited my curiosity, as it gave me the idea of a vein worked under-ground, and containing those substances in the matrix as originally formed. On expressing to the owner my desire to see the works, he kindly undertook to accompany me to the spot. After walking about half a mile up the mountain just mentioned, I was shewn two breaks or slips, in which my guide informed me were the topaz mines. We entered one of them, which was in extent little short of two acres; the argillaceous schistus, which formed the upper stratum, appeared in a variety of stages, the greater part migrating into micaceous schistus. In one part I observed two negroes poking in the little soft veins, which the slips disclosed, with a piece of rusty iron, probably part of an old hoop; and on enquiring what they were about, I was informed they were the *miners*, searching for topazes. I took one of their instruments, and on using it as they did, found these veins to contain a very minute micaceous substance approaching to earthy talc, also some quartz, and large crystals of specular iron ore. I had the good fortune to find two or three topazes, which, as they had only one pyramid each, and appeared fractured, I judged to be out of their original place. It had hitherto been my opinion, that all the topazes which I had seen at Rio de Janeiro, or elsewhere, and which were of similar form to these, had been broken from the matrix by the miners; I now, therefore fully expected to meet with some having double pyramids, but to my great disappointment all that I found were entirely detached. From a great quantity (at least a cart load) of inferior topazes, which were afterwards shewn to me in the owner's house, (and any number of which I might have taken away,) I could not select one with a double pyramid. They informed me that sometimes, but

very rarely, topazes had been found in quartz crystals, but even in these instances the quartz appeared fractured and out of its original place*. The topazes which were shewn me, were very imperfect, and full of flaws. The negroes employed in these works were superintended by two Creolians who received what they found.

After I had collected a variety of specimens, we returned to our mules, continued our journey over bleak and sterile mountains, through roads covered with dust, and arrived about three o'clock in sight of Villa Rica. Though the town stands on an eminence rather steep and lofty, the approach to it is not noble or striking, neither is there any thing in a near view of it, which, to the eye of a traveller, corresponds with the grandeur of its name. The environs, unlike those of opulent towns in general, exhibited few signs of cultivation; not an acre of good pasture was any where to be seen, nor an inclosure of any kind. We arrived a little after four, and alighted at one of the first houses to the left, on entering the town; it had been recommended to us as one of the best inns, but we found that in point of cleanliness and accommodation, report had greatly over-rated it. The owner, being a priest, entrusted the entire management to a mulatto, who acted as if he was seldom under the eye of his master. Having ordered dinner we walked into the town for about a mile; the streets were very irregular, and so badly paved as to give us no favourable idea of the opulence of the inhabitants. As night was coming on, and we felt fatigued, we postponed delivering our letters until next day, and returned to our inn. Our dinner, which was served up in as slovenly a manner as we had ever witnessed, even in the poorest rancho on the road, consisted of some stewed beef and a fowl. The bread was tolerable, but dear. Being little inclined to sit up after our repast, we re-

* They also informed me that green topazes were sometimes found, which I very much doubted. If any substance of that colour, resembling topaz, did occur, it was most probably *Euclase*, which may be easily mistaken for it.

tired early to rest ; our rooms, though destitute of almost every appropriate convenience, were better than those to which we had of late been accustomed.

Notwithstanding the fatigue of the journey, which heartily disposed me to sleep, my mind was for some time occupied in reflecting on the place at which we had now arrived, and which had long been the theme of our wonder and conjecture. Villa Rica — the rich village! The capital of the province of Minas Geraes, and the seat of its Government ; a place which had for many years been reputed the richest in Brazil, as to it was brought all the gold found in the vast district around. Impatient to see some vestiges of that splendor which its name implies, I slept but little, and rose at an early hour. We, with difficulty, obtained our breakfast, consisting of coffee and eggs, with bread and English butter, after which we dressed and went to deliver our letters.

Our arrival being announced, we were directed to present ourselves at the audience-chambers, which form part of a large edifice, containing also the Post-office and other public rooms for the transaction of Government business. We were introduced to the General of the Forces, and to Dr. Lucas, Judge of the Supreme Court, the latter held the principal authority in the absence of the Viceroy who was gone to Rio de Janeiro, another from Goyazes being expected shortly to succeed him. We were honoured with a most handsome reception, and various houses were put in our choice, with a kind invitation to make use of any of them during our stay, but we preferred taking lodgings in the centre of the town, within three minutes walk of the Palace, in Rua de Dereito, the very Bond Street of Villa Rica.

After our interview with the Judge, we devoted some hours to a perambulation of the town, and returned much fatigued to dine at our inn. In the evening I paid a visit to the vicar, who gave me a hearty welcome, and in the usual style of Portuguese compliment told me his house was mine. The saying, had it been verified,

would have put me in possession of one of the best mansions in Villa Rica. At tea the worthy pastor introduced me to several officers, among whom was the late governor of the Diamond district, who gave me much information concerning it and shewed me an aqua marina, which had been found in one of the washings. It was a perfect hexagonal prism, full seven inches in length and three quarters of an inch in diameter, clear and free from flaws. After some hours of very agreeable conversation, the party broke up, and it being dark, I was conducted to my inn by a servant of the vicar's, with his lantern. At the corners of the streets, along which we passed, there were groups of the lower order of people offering their prayers; in a niche above them was a figure of the Virgin, with tapers burning before it. A voice in a low solemn tone uttered the vespers, the responses were made by the multitude. I took off my hat as I passed, knowing that such a token of reverence is always expected.

The next day was occupied chiefly in removing our equipage to our new lodgings in Rua de Dereito; to this service our soldiers were particularly attentive, and left us nothing to do which they could do for us. On the day following we were honoured with visits from the judge, the general, the vicar, and many of the principal inhabitants, all of whom testified their respect for us in the most polite manner. Many of them afterwards sent me presents of fine sugar, coffee, sweet-meats, cheese, and some good bread. One gentleman, to give me a proof of the richness of the soil and salubrity of the climate, sent me a cabbage, full fourteen inches in diameter, when stripped of its outside leaves; a finer vegetable never was produced.

When our leisure permitted, we took excursions to view the town and its vicinity, sometimes on horseback and sometimes on foot, generally going and returning in a different direction. It is situated on the side of a large mountain, connected with others forming an immense chain, of which it is one of the highest. Most of the streets range, in steps, as it were, from the base to the summit, and

are crossed by others which lead up the acclivity. It is most admirably supplied with water, which is conducted into almost every house in a most convenient and pleasant manner. In the streets are many fountains, which, though not to be compared with those of Italy in architectural taste, are well constructed. One cistern in particular contained water which tasted strongly of sulphate of iron; the natives consider it serviceable in the cure of cutaneous diseases, and frequently bathe in it. The town is divided into two parishes, and contains a population of about twenty thousand inhabitants, of whom there are more whites than blacks. The climate is delightful, and perhaps equal to that of Naples. Though the latitude of the place is only 20° South, yet owing to its elevated site, the temperature of the air is generally moderate. The thermometer never exceeds 82° in the shade and is rarely below 48° , but its usual range is from 64° to 80° in summer, and from 48° to 70° in winter. The greatest heats prevail in January. Owing to its great elevation various changes from heat to cold prevail in the same day, and there are frequent showers of rain. Thunder-storms are common, but by no means violent. The sun is sometimes clouded by dews and mist so dense as not to subside until the forenoon is far advanced.

The gardens here are laid out with great taste, and from the peculiarity of their construction present a curious spectacle. As there is scarcely a piece of level ground, even ten yards square, on the whole side of the mountain, the defect has been remedied by cutting spaces one above another at regular distances, and supporting them by low walls, the top of one being on a level with base of that next above it. An easy flight of steps leads from one level to the other. These terraces seemed to me to be the very kingdom of Flora, for never did I before see such a profusion of delicate flowers. Here were also excellent vegetables of every kind, such as artichokes, asparagus, spinach, cabbage, kidney-beans, and potatoes. There are many indigenous fruits which might be much improved by a better system of horticulture. The peach appears

to be the only exotic fruit which has been hitherto introduced ; it flourishes amazingly. I have frequently seen the branches of the trees so loaded as to require perpendicular support.

The town is of considerable extent, but by no means so well peopled as when the mines were rich. Few of the inhabitants have any employment except the shopkeepers, who are indeed a numerous class. English woollens were by no means dear, superfine cloth being at 30s. to 35s. per yard, coatings, &c. nearly as cheap as in England ; common cotton prints at 1s. 6d. to 2s. per yard ; hats, handkerchiefs, kerseymeres, and Manchester piece goods in great plenty. There seemed indeed to be a glut of English merchandize and produce of all sorts, except earthenware, hams, porter, and butter, which were dear on account of the risk of carriage. Common Figueras wine was at 3s. 6d. the bottle. The shops that sold the produce of the country were few in number and very indifferent. There were a great many taylor's, shoe-makers, tin-workers, and venders of hardware, some smiths, and no inconsiderable number of saddlers. In a country where every one is a horseman, this trade must, one would imagine, take the lead of most others. The saddles that were shewn me here were of a much superior make to those which I saw in Rio de Janeiro. I was surprised to find no workers in gold in a place so renowned for the production of that precious metal, but I was informed that the trade was prohibited by law, to prevent the gold from being worked before it was permuted. The market of Villa Rica was but ill supplied, notwithstanding the fertility of the district around it. Pulse and vegetables for the table were scarce, even grass was an article in great demand *, and milk was as dear as it is in London. Poultry sold at from 3s. 6d. to 4s. 6d. per couple. Beef of a tolerable kind, but by no means good, might be had at 1½d. per pound, Pork was very fine ; mutton

* Our mules required at least six-pennyworth each per day, exclusive of their corn.

was utterly unknown. Tallow was exceedingly dear, and candles were at more than double the price at which they sell in this country.

Though our arrival in the town excited some surprise, as we were the first of our nation who had visited it, yet the people did not regard us entirely as strangers, many of them having seen Englishmen in their frequent intercourse with Rio de Janeiro. My worthy companion had letters to some of the principal shopkeepers, which we took an early opportunity of delivering. When we spoke to them of the richness of the country, and of the quantity of gold with which it was reputed to abound, they seemed glad of the opportunity of telling us, that they believed the gold was all sent to England, adding that their town ought now to be termed Villa Pobre, instead of Villa Rica. Indeed we were surprised to observe the comparative poverty which prevailed among them. Of above two thousand habitations, which the town contained, a considerable proportion were untenanted; and the rents of the rest were continually lowering. Houses were to be purchased at one half their real value; for instance, a house built a few years ago at 1000*l.* cost, would not now sell for more than 500*l.*

The mountain on which the town stands, appeared to me in length from eight to nine miles, in every part narrow and almost insulated, being surrounded by deep ravines. In riding over it in various directions, I observed it to be composed of argillaceous schistus in almost every gradation, migrating from the compact blue slate into micaceous schistus. In some parts it lies in regular laminæ, in others it appears in confused masses. The slate is sometimes, but not very generally, used for paving, roofing, and other similar purposes. In some parts I noticed a few slender, confused, and irregular quartzose veins of little consequence, a large proportion of ferruginous accumulations and conglomerations, together with martial pyrites, and a considerable quantity of rounded quartz of all sizes. That side on which the town is built presents many small

hills, which form a number of gulleys in narrow ravines. Numerous streamlets flow down from the springs in the mountain in various channels, and in rainy weather swell into cascades; they form a stream at its base called Rio del Carmen, which in its course from hence is joined by many others, and changes its name first into that of Rio St. José, and then into Rio Doce. Of the latter I shall have occasion in the sequel to speak more at large.

CHAP. XI.

Origin and present State of Villa Rica. — Account of the Mint. — Visit to the City of Mariana. — Excursion to the Fazendas of Barro and Castro, belonging to His Excellency the Condé de Linhares.

THE history of an establishment which, twenty years after its foundation, was reputed the richest place on the globe, was an object of considerable interest with me, and I made many inquiries respecting it from some of the best informed men on the spot. It appears that the first discovery of this once rich mountain was effected by the enterprising spirit of the Paulistas, who, of all the colonists in Brazil, retained the largest share of that ardent and indefatigable zeal for discovery which characterized the Lusitanians of former days. They penetrated from their capital into these regions, braving every hardship, and encountering every difficulty which a savage country, infested by still more savage inhabitants, opposed to them. They cut their way through impervious woods, carrying their provisions with them, and occasionally cultivating small patches of land to afford them food to retreat to, in case of necessity, as well as to keep up a communication with their city, St. Paul's. Every inch of ground was disputed by the barbarous Indians, here called Bootocoodies, who were constantly either attacking them openly or lying in ambush, and but too frequently succeeded in surprising some of them, or their negroes, whom they immediately sacrificed to their horrible appetite for human flesh. They believed the negroes to be the great monkeys of the wood. The bones of the unfortunate sufferers were frequently found exposed, shocking testimonies of the barbarity of their murderers, whom the Paulistas,

roused to revenge, invariably shot, wherever they met them. These examples of vengeance answered their desired end; the Indians, terrified as well by the noise as by the fatal effect of the fire-arms, fled with precipitation, believing that the white men commanded lightning and thunder.

It does not appear that in exploring this territory they received any assistance whatever from the Aborigines; they followed the course of rivers, occasionally finding gold, of which they skimmed the surface, and continued to proceed until they arrived at the mountain which is our present subject. Its riches arrested their course; they immediately erected temporary houses and began their operations. The principal men of the party that first settled here, were Antonio Dias, Bartholomew Rocinho, Antonio de Ferrera (filho), and Garcia Ruis. It appears that they took the most direct way to the place, for the roads they then opened are the same which are still used. The fame of their success soon reached the city of St. Paul's; fresh adventurers arrived in great numbers, bringing with them all the negroes they had means to purchase. Other adventurers went from St. Paul's to Rio de Janeiro to procure more negroes, their own city being drained; and thus the news of the lately discovered gold-mountain being made known in the Brazilian capital, men of all descriptions went in crowds to this land of promise by the way of St. Paul's, which was the only route then known. The first settlers might have prevented the exposure of their good fortune, had they been able to moderate their joy, and consented to act in concert; but as gold was in such great abundance, every individual appropriated a lot of ground, and thus became a capitalist. Each strove which should make the most of his treasure in the shortest time, and thus there was a continual demand for more negroes, more iron, &c. and, in the general eagerness to obtain them, the secret which all were interested in keeping was disclosed. The Paulistas, independent in spirit, and proud of their wealth, were desirous of giving laws to the new-comers; but the latter determining to oppose

this measure, formed themselves into a party under the guidance of Manuel Nuñez Viana, an adventurer of some consequence, who strenuously asserted their claim to equal rights and advantages. Disputes arose on both sides, and were at length aggravated into hostilities, which proved unfavourable to the Paulistas, the greater part of whom fled to a considerable station of their own, and there awaited reinforcements. Viana and his followers, without loss of time, went in pursuit of their foes, whom they found on a plain near the site of St. João del Rey. The two parties met on the borders of a river, and a sanguinary battle took place, which ended in the defeat of the Paulistas, who afterwards made the best terms they could. The slain were buried on the margin of the river, which, from that circumstance, took the name of Rio das Mortes.

The Paulistas, bent on revenge, but weakened by defeat, appealed to the sovereign, King Pedro, denouncing Viana and his followers as rebels who were attempting to take the district to themselves, and set up an independent government. The King's ministers, apprized of the state of affairs, and learning by report the immense riches of the country, immediately sent a chief, with a competent body of troops, to take advantage of the strife between the two parties; which, in a country tenable by a few men on account of its numerous strong-holds, was a most fortunate circumstance. The name of this chief was Albuquerque; a man of enterprize and perseverance, in all respects qualified for the service on which he was sent. His appearance at first occasioned much confusion and discontent among both parties; and though he was not openly opposed, yet he was in continual alarm. The Paulistas now saw that the riches which they in conjunction with their rivals might have retained, were about to be seized by a third party which would reduce them both to subordination. Disturbances prevailed for some time, but reinforcements continually arriving from Government, tranquillity was at length perfectly established; and in the year 1711 a regular town began to be formed; a government-house, a mint, and a depôt for arms were

built. A code of laws was enacted for the regulation of the mines ; all gold-dust found was ordered to be delivered to officers appointed for that purpose ; a fifth in weight was taken for the King, and the remaining four parts were purified, melted into ingots at the expence of Government, then assayed, marked according to their value, and delivered to the owners, with a certificate to render them current. For the greater convenience of trade, gold-dust was likewise permitted to circulate for small payments. Notwithstanding these strict regulations, a considerable quantity of the precious metal in its original state found its way to Rio de Janeiro, Bahia, and other ports, clandestinely, without paying the royal fifth, until Government, apprized of this illicit traffic, established registers in various parts for the examination of all passengers, and stationed soldiers to patrole the roads. By these means, gold in immense quantities was seized and confiscated ; the persons on whom any was found forfeited all their property, and, unless they had friends of great influence, were sent as convicts to Africa for life. The greatest disgrace was attached to the name of smuggler ; and such was the rigour of the law against offenders of this description, that every person quitting the district was obliged to take a certificate stating whither he was going, and what he carried with him. This regulation is still in force, and is rigorously observed.

Villa Rica soon enjoyed a considerable trade with Rio de Janeiro ; the returns were negroes, iron, woollens, salt, provisions of various kinds, and wine, all which at that time bore amazingly high profits.

About the year 1713, when Dr. Bras de Silvia was appointed governor, the quantity of gold produced was so considerable that the royal fifth amounted to half a million sterling annually. The mountain became pierced like a honey-comb, as the miners worked every soft part they could find, and penetrated as far as they could, conveying the *casalhão* which they dug out to a convenient place for washing. In rainy weather the torrents of water running down the sides of the mountain, carried away much earthy matter containing

delicate particles of gold, which settled in the ground near its base. When the waters abated, this rich deposit gave employment to numbers of the poorer sort of people, who took it away and washed it at their convenience.

Antonio Dias, the person already mentioned as one of the leaders of the Paulistas, who discovered the place, having become extremely rich, built a fine church, and dying soon after, bequeathed to it considerable funds. It still bears his name. Five or six others were begun and soon finished, as neither wood nor stone was wanting, and the inhabitants were all ready to contribute a share of their property, and to employ their negroes in furtherance of these pious works. A law highly creditable to the wisdom of the Portuguese government was now enacted, to prohibit friars from entering the territory of the mines. What treasures were thus saved to the state, and what a number of persons were thus continued in useful labour, who would else have become burthensome to the community!

The town now underwent many improvements; its streets were more regularly built, and some parts of the side of the mountain were levelled to afford more convenient room for the construction of houses, and the laying out of gardens. Reservoirs were formed, from which water was distributed by means of conduits to all parts, and public fountains were erected in the most convenient and central situations. The mint and smelting-houses were enlarged, and rendered more commodious for the transaction of business. About this period the inhabitants amounted to twelve thousand or upwards; those who possessed mines were either the first settlers or their descendants, and as the best part of the district was occupied, the new adventurers who continued to arrive from time to time were obliged to enter into the service of the existing owners until they had learned their methods of working, after which they generally went in search of fresh mines, proceeding along the water-courses and ravines, where they sometimes discovered new sources of wealth. Between the years 1730 and 1750 the mines were in the height of their prosperity; the King's

fifth during some years of that period is said to have amounted to at least a million sterling annually.

The mines which produced this immense wealth at length became gradually less abundant; and, as the precious metal disappeared, numbers of the miners retired, some to the mother-country, loaded with riches, which tempted fresh adventurers, and many to Rio de Janeiro and other sea-ports, where they employed their large capitals in commerce.

Villa Rica at the present day scarcely retains a shadow of its former splendour. Its inhabitants, with the exception of the shopkeepers, are void of employment; they totally neglect the fine country around them, which, by proper cultivation, would amply compensate for the loss of the wealth which their ancestors drew from its bosom. Their education, their habits, their hereditary prejudices, alike unfit them for active life; perpetually indulging in visionary prospects of sudden wealth, they fancy themselves exempted from that universal law of nature which ordains that man shall live by the sweat of his brow. In contemplating the fortunes accumulated by their predecessors, they overlook the industry and perseverance which obtained them, and entirely lose sight of the change of circumstances which renders those qualities now doubly necessary. The successors of men who rise to opulence from small beginnings seldom follow the example set before them, even when trained to it; how then should a Creolian, reared in idleness and ignorance, feel any thing of the benefits of industry! His negroes constitute his principal property, and them he manages so ill, that the profits of their labour hardly defray the expences of their maintenance: in the regular course of nature they become old and unable to work, yet he continues in the same listless and slothful way, or sinks into a state of absolute inactivity, not knowing what to do from morning to night. This deplorable degeneracy is almost the universal characteristic of the descendants of the original settlers; every trade is occupied either by mulattoes or negroes, both of which classes seem supe-

rior in intellect to their masters, because they make a better use of it.

During my stay here I paid frequent visits to the mint, and was liberally permitted by the officers to see every process performed there. In the smelting-house were eight or ten small blast-furnaces, in form much resembling blacksmiths' hearths. The fuel used is charcoal. When a quantity of gold-dust is brought, (no matter whether large or small,) say, for instance, six ounces, it is first permuted, and a fifth taken for the Prince; the rest is put into a Hessian crucible about three inches in diameter, which is immediately placed in the furnace. A quantity of corrosive sublimate is then put to it, which, on being heated, exhales very strong fumes; the scorixæ, if any be formed, are taken off with a pair of tongs, and more sublimate is added if required. Ebullition sometimes occurs, in which case the crucible is covered with a bit of common tile. As soon as the mercury is evaporated, the gold is poured into an ingot-mould, previously rubbed with animal fat; it is afterwards turned out into a tub of water. The ingot generally, in some part or other, has mercury attached to it, which it seizes immediately, and the part of the gold thus affected assumes the appearance of lead*. To remove this, they hold it in a strong fire with a pair of tongs until the mercury is evaporated. It is afterwards sent to the assay-master, who first compares it on the touchstone with gold bars of different alloys, ascertained and marked, and then assays it. The two methods being found to agree, the assay-master stamps upon the ingot its degree of fineness, (called *toque*,) also its weight, its number, the name of the place, and the year. It is then registered in a book kept for that purpose, and a copy of the entry is made out on a slip of paper, in which the ingot is wrapped, and delivered

* In England I once knew an instance in which an ingot with mercury thus adhering to it, in the possession of a person ignorant of metallurgy, was sold at a reduced price, as if the discoloured part had really been lead; the purchaser also supposing that to be the case.

to the owner for circulation. The operation of melting a given quantity seldom occupies more than ten minutes or a quarter of an hour; that of cupelling about double the time: but I have seen men deliver their gold-dust, and receive it in a circulating form in less than an hour; so that little delay takes place, and as there are six furnaces, the bringers of gold have seldom to wait for their turn. The pale colour and low quality of various bars of gold are always imputed to the silver, platina, or other metal contained in them. I have seen some as low as sixteen carats, and others as fine as $23\frac{1}{2}$ carats, which is within half a carat of what is denominated pure gold. Twenty-two is the standard, and gold exceeding that receives a premium according to its fineness.

Considerable quantities of arsenical pyrites, said to be cobalt, were brought to me: I examined some specimens with the blow-pipe, but found no vestige of that metal, as the substance in no stage imparted a blue colour to borax or glass. Martial pyrites is found about three miles from the town, where there is a very strong vein of it in quartz. Antimony was brought to me from some distance, and also a few bits of copper much oxidated, which were said to have been found in the washings at a town called Caldrones, but this I had great reason to doubt. Not a few impositions respecting the discovery of copper were attempted upon me. One man brought a rounded piece of jasper, about an ounce in weight, and with it half an ounce of copper, of the form and about the size of a duck-shot, which he told me had been produced by smelting a stone similar to the jasper then before me. I with much difficulty persuaded him that the person who had performed the operation for him had dropped a copper coin into the crucible. I was astonished to find that many persons, even gentlemen of some consequence, had a notion that almost every red-coloured stone in the pavement of the streets was copper. One fellow had circulated a report that he possessed several pieces rich in that metal; but, on being sent for, and questioned closely, he stated that he had lost them in removing

to another house. It is not surprising that tales of this kind should gain easy credit among persons stimulated by avarice and blinded by ignorance, and that the artful men who invent and propagate them, should be tempted by success to repeat their impositions, and corrupt others by their example. The rich iron ores with which the district abounds, and of which I saw many specimens, might furnish employment much more profitable than washing for gold, or following other idle and chimerical speculations.

During the first few days of my residence here, my soldiers procured me a quantity of the finest porcelain clay I have ever seen; that used in the manufactory at Sèvres near Paris is inferior to it. It is found at the foot of a mountain of argillaceous schistus, called San Antonio, near Cangones do Campo, in a vein accompanied with quartz and specular iron ore.

A week after my arrival here, I was invited to go to a pottery about three miles distant. Crossing a bridge over the Rio del Carmen, at the foot of the town of Villa Rica, we ascended another steep mountain, on the summit of which I found iron ore in great quantities. Though not very rich, I have no doubt it would produce 25 per cent. of metal. The want of wood, which is here complained of as an objection to working it, might be remedied by planting; for this summit is a fine plain which proper cultivation would render highly productive. At present, though so near the town, it lies totally neglected, without a single inclosure upon it. The pottery, at which we soon arrived, has been but recently established. The clay is used in its native state, without any admixture, and is cleared of its coarse particles by washing. After the water has been let off and evaporated so as to leave it of a sufficient consistency, it is put on the wheel and formed into plates, mugs, jars, &c. which are bulky and heavy, but by no means strong. They are rendered less fragile by being covered with an excellent thick glazing. The furnaces have no chimneys, but consist merely of a low arch in which are several vent holes. The glazing furnace

is reverberatory, but it is so ill constructed as to destroy much fuel and produce little heat. Throughout the whole district there is fine coarse clay for bricks, tiles, &c.

I was here invited to taste some wine, made from grapes grown on the spot, which was excellent. A more happy situation than this vicinity affords for the growth of fruits of every kind can scarcely be imagined. The pear, the olive, and the mulberry would thrive here equally well with the grape, if proper pains were taken with them. A skilful agriculturist would with great ease, I am certain, bring it into such a state of improvement as to serve the double purpose of a corn and dairy farm; excellent wheat might be grown, and a certain quantity of the land kept under artificial grasses for cutting. A fine stream of water runs through the whole, with a sufficient fall to turn mills.

The principles of husbandry seem as little understood here as in any part of the territory through which we had hitherto travelled. Perhaps there is no country on the globe where the vicissitudes of plenty and scarcity do not prevail, and where human experience has not shewn the necessity of laying by a store in time of abundance, as a provision for a season of famine; but here this salutary practice is almost wholly disregarded. The cattle are turned out on the unenclosed tracts*, and left to subsist on whatever they can find. In the summer months, when the grass throughout the wide extent is burnt up, they flock to the margins of the rivulets as their last resource, which soon fails. Numbers of them die of famine, and those that survive the season are so exhausted and weakened that they seldom thoroughly recover.

A small mount in the vicinity of this pottery presented much ferruginous matter, and a substance that appeared to me barytes in a mamillary form, a specimen of which I took with me. Since

* The finest parts of these tracts, in the best season, are by no means so rich in grass as an English meadow.

my return to England it has been proved by the analysis of the eminent Dr. Wollaston to be hydrargylite without fluoric acid.

During my stay at Villa Rica, I rode to the city of Mariana, distant eight miles, by a tremendous and almost impassable road, along a ridge of mountains; and afterwards went thither by the general road which passes between two high hills, and for some distance along the river side, all the way on the descent. The margins of the Rio del Carmen, which runs through the town, have been washed the whole way from Villa Rica, parties from which place held possession of this settlement as early as the year 1710, claiming it on account of the gold brought down from thence by the current of the river. It was made a bishop's see about the year 1715, and was called Cidade de Mariana, in honour of the then reigning Queen of Portugal, the present Prince Regent's grandmother. It is a small, neat, and well-built town, containing from six to seven thousand inhabitants. Here is a college for the education of young men destined for the church. The bishop is a prelate of exemplary character, and is beloved by all who know him. The place has very little trade, and depends chiefly on the mines and farms in its vicinity. Many miners reside here whose works are several leagues distant, some of them extending to the village of Camargo, situated beyond a large plain which stretches westward from the confines of the city.

Having resided in Villa Rica nearly a fortnight, I expressed a desire to visit two estates, forty miles distant, known by the names of Barro and Castro, both belonging to the Condé de Linhares. Between the years 1730 and 1740 these estates produced much gold, and were then in the possession of Senhor Matthias Barbosa, a settler of great respectability, who took up these lands and drove the Anthropophagi from them. He, becoming very rich, sent his only daughter to Portugal to be educated, where she remained, and after his death inherited his whole property. She was married in Lisbon to a gentleman of the family of Souza, and from them are

descended the two noblemen of that name, who now hold high official situations under the Prince Regent. His Excellency the Condé's steward furnished me and my worthy friend with mules, and Mr. Lucas, the Judge, obligingly ordered every necessary to be provided for our journey. We rode through Mariana, and arrived at Alto de Chapada, a village, three miles distant from it, situated on an elevation in the midst of a fine plain. We soon afterwards reached a very high and confined situation, between two perpendicular mountains, from whence we had a bird's eye view of the village of St. Sebastian. From this steep we descended, with great difficulty, on foot, to the Rio del Carmen at its base, over which is a very high-arched and picturesque bridge. Passing this ravine we proceeded a full league by the river side, through a rich country abounding in fine sloping hills and fertile plains, watered by numerous streams which flow into the river in various directions, and all of which bear vestiges of having been formerly washed for gold. The road side exhibited similar remains, and seemed to have been at some period connected with the river, which, in this part, is as large as the Thames at Windsor. We passed through San Giatanha, a straggling thinly peopled village, and proceeding about three miles further, arrived at an indifferent house, called Lavras Velhas, where we halted for the night, having performed half our journey. The owner of this place found it difficult, with thirty or forty negroes, to maintain himself deceptly, though the land was susceptible of every species of culture, and needed only the hand of industry to render it productive. Every thing about the establishment exhibited a pitiful spectacle of neglect, indifference, and sloth. It is but justice to add that he treated us with the greatest civility, and amply supplied our necessities.

Leaving Lavras Velhas at eight next morning, we passed Morodos Arreas, the country presenting still finer valleys and excellent timber, but totally destitute of cattle. Ascending a high hill we were immersed for about an hour in a cloud, and exposed to some

small rain, but not sufficient to penetrate our coats. This was the only rain we experienced on the road by day. In the night the rain sometimes fell plentifully. We observed some exceedingly large worms, stretched motionless on the road, which our guide told us were sure signs of wet weather. From this height we saw the Rio Gualacha, which, with another river, joins the Rio del Carmen about ten leagues below, and forms the Rio San José. Proceeding in that direction through a fine country, we reached Altos de St. Michael, where the river last mentioned is of considerable width, but not deep. Its waters are extremely turbid, on account of the mud brought from the gold-washings along the banks, from its source to this place. These heights command a fine view of three windings of the river; at their base there are vestiges of one of the oldest and most extensive gold-washings, which yielded much treasure to its discoverer and proprietor, Senhor Matthias Barbosa. The country is well-wooded, but rather thinly peopled; I expressed some surprise at observing no good dwelling-houses in a district which formerly produced so much wealth, and was informed that the first miners, eager to take the cream of the gold to as large an extent as they could, seldom remained long on the same spot, and contented themselves with building sheds or ranchos to serve for their temporary residence.

Descending this mountain, we entered upon the estate of His Excellency, called Fazenda do Barro, and were shewn the house at a distance of nearly a league, on a pleasing eminence, near the river-side. On arriving, an excellent dinner was provided for us, of which, having been eight hours on our mules, we partook very heartily.

The house, and indeed the whole establishment, were strikingly superior, in point of convenience, to the miserable places we had lately passed. Having dined, we refreshed ourselves with a walk in garden, where the coffee-trees in full blossom shewed, at a distance, as if loaded with snow. This spot afforded a view of a most en-

chanting country, diversified with gentle eminences and large valleys well clothed with timber. From the farther margin of the river, which flows at one hundred yards distance in front of the house, rises a fine hill, well calculated for the culture of every species of produce, and connected with others of equal fertility.

On the following day I was chiefly occupied in visiting every part of the establishment. The distil-house, sugar-engine, and corn-mill, were very much out of repair; the two latter were worked by horizontal water-wheels of great power. The buildings of the fazenda form a square, the southern side being occupied by the house, and the three others consisting of dwellings for the negroes, store-houses, carpenters' and blacksmiths' shops, and other offices equally useful.

Having requested to see the cattle, I was shewn seven fine well-proportioned cows; their calves were old, and they being unaccustomed to be milked regularly, gave very little. I signified to the people my wish to instruct them in the management of a dairy after the English mode; and the carpenter hearing my description of a churn, readily assured me that he could make one, and set about it forthwith in the following manner. He procured a trunk of a tree of the length and girth required; sawed it lengthwise in two equal parts, which, (after hollowing them sufficiently, and preparing a bottom,) he joined with two iron hoops so tightly as to hold water. The churn-staff and top were soon finished: but now an unexpected difficulty occurred; here was no place free from dust and dirt to serve for a dairy, nor any pan fit to hold the milk. All the cooking-pots that could be spared were cleaned for this purpose, but they were quite of the wrong make, being wide at the bottom and narrow at the brim. They were, however, laid by along with the churn, to be used the first time the cows were milked. The good lady of the house assisted in our preparations, and seemed much interested in them.

In the afternoon I rode out to see the gold-washings. On the way thither I observed a man training a horse, with a cord attached to the bridle in one hand, and a whip in the other. Two pieces of leather in the form of breechings were sewed to two iron rings; one part was put over the back of the animal, the other part slipped down as a breeching; the part on the back was to prevent its slipping lower. To these rings were tied cords from the horse's fore-feet, capable of being shortened or lengthened at pleasure. The horse being put in motion, took very short fore-steps, somewhat like those of the chargers in equestrian performances. Horses thus trained are here called *pacers*, and are in great request among persons of distinction of both sexes, their gait being very easy and graceful.

On arriving at the washings I saw a great extent of ground already worked, and immense heaps of quartzose stones. On the margin of the river where they were then working, I found them cutting away the bank, to the depth of at least ten feet, to get at the *cascalhão* incumbent on the rock. The substance they had to cut through was clay, so strong that, though falls of water were let upon it, and negroes were constantly working it with hoes of various kinds, it was with difficulty to be removed. This was not the only impediment, for, by the constant precipitation of mud, the *cascalhão* was five feet below the bed of the river; hence, when they had sunk their pits, they had to use means for drawing the water from them. The hydraulic machines employed for this purpose are constructed as follows: A trough or spout, made of four stout planks, forming a cavity, say six inches square, is placed in an inclined position, with its lower end in the pit, where a roller is properly secured to a pile driven into the ground: an iron chain, with peculiar links, on every one of which is fixed a piece of wood, nearly answering the interior dimensions of the spout, is passed through it, then under the roller, and over the outside, up to the axis of a water-wheel, which being put in motion, causes the discharge of a column of water equal

to the cavity. These machines are calculated to raise a great deal of water, but they are liable to be thrown out of repair. In many cases hand-pumps would serve the purpose better, being made at little trouble or expense, easily repaired, and always ready at an hour's notice. They are here utterly unknown.

In the operation of getting gold, the heavy work is assigned to the male negroes, and the lighter labour to the females. The *cascalhão*, dug from these pits by the former, is carried away by the latter in *gamellas*, or bowls, to be washed. When a sufficient quantity has been procured, the men proceed to that process, which they perform much in the way already described in treating of St. Paul's. I perceived, however, that here they did not, in the first instance, attempt to separate the gold from the black oxide of iron, but emptied their *gamellas* into a larger vessel, by rinsing them in the water which it contained. The substance deposited in this vessel was delivered out, in small portions of about a pound each, to the most skilful washers, as the operation of washing, or, as it was termed, purifying it, required great niceness and dexterity. Some of the grains of gold were so fine as to float on the surface, and of course were liable to be washed away in these repeated changes of water; to prevent which the negroes bruised a few handfuls of herbs on a stone, and mixed the juice in small proportions with the water in their *gamellas*. Whether this liquid did in reality tend to precipitate the gold, I could not positively ascertain, but the negroes certainly used it with the greatest confidence.

There is another mode of separating the gold from the *cascalhão*, called canoe-washing, which is extremely interesting. The canoes are made in the following manner: Two ten or twelve inch planks, about twelve or fifteen feet in length, are laid on the ground, forming an inclined plane, sloping about one inch in twelve: two other planks of similar dimensions are fixed in the same direction at the lower end, forming a second inclined plane, with a fall of six inches from the former. On their sides are boards placed edge-wise, and

staked down to the ground so as to form long shallow troughs, the bottoms of which are covered with hides tanned with the hair on, having the hairy side outwards, or, in defect of these, with rough baize. Down these troughs is conveyed the water containing the oxide of iron and the lighter particles of gold; the latter substance precipitating in its course is entangled by the hair. Every half-hour the hides are taken up, and carried to a tank near at hand, formed of four walls, say five feet long, four broad, and four deep, and containing about two feet depth of water. The hides are stretched over this tank and well beaten, then dipped and beaten repeatedly, until all the gold is disentangled, after which they are carried back and replaced in the troughs. The tanks are locked up at nights, and well secured. The sediment taken from them being light is easily washed away by the hand in the manner before described, leaving only the black oxide of iron, called esmeril, and the gold, which is so fine that mercury is used to separate it. The process, as I saw it performed, was as follows: About two pounds weight of oxide of iron, very rich in fine grains of gold, was put in a clean bowl; a quantity of mercury, about two ounces, was added to it; the mass of oxide, which was very damp, was worked by the hand for about twenty minutes, when the mercury appeared to have separated the esmeril, and to have taken up all the gold, assuming a soft doughy mass, that retained any form into which it was squeezed. The grains of gold, however, remained not amalgamated with, but merely enveloped in, the mercury. The mass was put into a folded handkerchief, and an ounce or more of mercury was wrung or squeezed from it. The rest was put into a small brass dish, covered with a few green leaves, and then placed over a charcoal fire, where it was stirred with an iron rod to prevent the gold from adhering to the sides of the dish. The leaves were occasionally changed as they became parched by the heat. When taken off, they exhibited in some parts small globules of mercury, and in others white oxide; on washing them with water, nearly half an ounce of the former substance was

obtained from them*. I ever observed that the gold after this operation was changed in colour from an agreeable soft yellow to a dirty brown, and presented a very different appearance from that which was not subjected to mercury.

. By way of suggesting an improvement, I made some drawings and models of earthen vessels for evaporating, and afterwards condensing the mercury ; but the quantity of gold requiring this mode of separation is so inconsiderable, that it would scarcely be worth their while to alter the process now practised.

I rode over various parts of the estate, and more particularly along both banks of the river, which, as well as the bed, appeared to have been much washed. The bends, or parts where eddies were formed, were the places noted as being rich in gold. Wherever the margin formed a flat, or level, the cascalhão continued under the surface to some distance, appearing like a continuation of the bed of the river, which in all probability it was, as the river is known to have been much wider formerly. The parts that were then working, and others that had yet to be worked, bore a very unpromising appearance.

An opportunity was soon afforded me of carrying into execution the proposed dairy experiment. Having obtained about six quarts of milk, (which, on account of the scarcity of grass, was very poor,) I put it into the culinary vessels that had been set apart for it ; but such was the state of the place in which they were deposited, that though I placed banana leaves over them, the surface next morning was covered with dust. I took off the cream in the best manner I could, but not being able to find a cellar or cold place for it to stand in, I was obliged to leave it in the same room with the milk, where it was hardly secure against the pigs. On each of the two following

* This species of sublimation on a small scale interested me greatly. Could it proceed from any glimmering of science in the minds of the negroes, or was it merely an accidental discovery ?

mornings I obtained about two gallons of milk, which being added to the other, was in due time churned ; and, notwithstanding the disadvantages of poor milk, improper utensils, and bad keeping, a tolerably fair proportion of good butter was obtained. The people seemed highly satisfied with the success of the process ; but I had strong doubts that they would not pursue it after my departure, as they must naturally dislike the trouble and care which it required. Such was the force of their habitual and long-cherished prejudices, that I have no hesitation in saying they would take ten times more pains to procure forty-shillings-worth of gold at an expence of thirty shillings, than they would to obtain forty-shillings-worth of butter, though it were only to cost them five.

It may be expected that I should assign some reasons for entering so frequently into detail upon one of the simplest branches of rural economy. I have to observe, then, that ere I left Rio de Janeiro to undertake this journey, I was informed that the cheese generally consumed in that capital, and regarded there as a luxury, was the produce of the district to which I was going. Its taste was sometimes so extremely rancid and disagreeable, as to be utterly unwholesome, and from this circumstance I judged that there must be great mismanagement in the preparation of it. All the farms which I had occasion to visit on my journey to Villa Rica, and from thence to this place, fully confirmed my opinion ; for, miserable as was the condition of every department belonging to them, that of the dairy was still worse. In the few places where they pretended to prepare milk for cheese, not only were the various utensils in an extremely filthy condition, but the rennet was so putrid as to be in the last degree sickening. I endeavoured to make the people sensible of the advantages of an improved mode of management, and wherever I had an opportunity, gave them information how to proceed ; but as oral or written instructions were little calculated to make a durable impression, I determined, when leisure and convenience should concur, to enforce them by example. The first and only opportu-

nity of this kind presented itself at the Fazenda do Barro; and I was the more induced to avail myself of it, from considering that the precedent which I wished to give to the farmers of the district would have greater influence by being sanctioned by the approval of His Excellency the Condé de Linhares. The result, as I have just observed, was not very flattering to my hopes; a solitary experiment can do little towards reforming a general evil of long continuance; and there is no probability that this or any other branch of the farming system of the country will be improved, until the great and the opulent zealously unite for the accomplishment of an object so highly important.

In our excursions through various parts of the estate, we observed on the exterior of many of the trees a great variety of crimson lichens, which, on being steeped in water, imparted a very strong tinge of that colour. Here were excellent barks for tanning, particularly that of a tree called *Canifistula*, which does not redden or colour the hide. We found many beautiful varieties of the jacaranda, or rose-wood.

Having resided at Barro some days, we set out for the Fazenda de Castro, distant about seven miles, where we arrived, after a pleasant ride over a mountainous and finely-wooded district, containing large tracts of rich virgin land, watered by many excellent streams. This noble mansion was erected by the first possessor of the district, Senhor Matthias Barbosa. It is very spacious and airy, having a gallery in front forty-eight yards long, to which open fourteen folding-doors, or windows, extending nearly from the top to the bottom of the rooms. It is situated near the confluence of the Riberon del Carmen and the Rio Gualacha, which form the San José, a river as large as the Thames at Battersea.

We did not rest above an hour at this fazenda, it being our intention to visit the aldea or village of San José de Barra Longa, situated on the confines of the territory inhabited by the Bootocody Indians. Crossing the river by a fine wooden bridge, built about fifty years ago, but still in tolerable repair, we proceeded along the bank, which

was embellished with several gardens, and presented more frequent appearances of cultivation than we had of late been accustomed to view. The climate is much hotter than at Villa Rica, on account of the lowness of the situation; and we were informed that fruits of every kind, particularly the pine, grew in this soil to great perfection in size and fineness of flavour. The truth of these accounts we could not ascertain, as this was not the fruit-season.

After travelling about four miles we arrived at the village. It being Sunday, numbers of people had come from various parts in the neighbourhood to attend divine service, and, after it was over, flocked in crowds to the place where we alighted. It appeared as if the whole population of the village, men, women, and children, were possessed with the same spirit of curiosity, so great was their eagerness to get a sight of us. We dined in a mixed company of ladies and gentlemen, at the house of the worthy vicar, who kept a very hospitable table, and paid us the most flattering attention. A military officer and a judge, who were of the party, entered into conversation with us; and it was difficult to decide who were the most inquisitive, they, respecting the motives and objects of our journey, or we, respecting the state of the country, the Anthropophagi, &c.

We learnt that the village was founded about twenty-three years ago by a number of Portugueze, who were tempted to settle, in a spot so exposed to the depredations of the Bootocoodies, by the gold with which it abounded. At the present day, I was informed that it contains about four hundred inhabitants, and that the vicinity is well peopled, so that a sufficient force is always at hand to repel the savages; who, no longer daring to attack openly, now have often recourse to stratagem. When they have marked out a house, and ascertained its strength, they set fire to it by shooting arrows with fire-brands into the roof, and fall on the unfortunate inhabitants as they are attempting to escape. These savages, accustomed to live in the woods, and well practised in all the arts requi-

site for catching the wild animals on which they subsist, have a thousand stratagems for way-laying the settlers. Sometimes they render themselves invisible by tying branches and young trees about them, and fix their bows imperceptibly, so that, when a poor negro or white happens to pass near them, they seldom miss their aim. At other times they rub themselves with ashes and lie on the ground, or make pit-falls, in which they place pointed stakes, and cover them with twigs and leaves. They have a great dread of fire-arms, and betake themselves to flight whenever they hear them: but these weapons are by no means so general among the settlers as they ought to be, and the few they have are of very indifferent make, and frequently altogether useless. It sometimes, though rarely, happens, that the soldiers surprise the aborigines, in which case no combat takes place; the latter run away as speedily as possible; and their pursuers, taking vengeance for injuries sustained, seldom give quarter. Those whom they make prisoners they are obliged to tie hand and foot, and carry on a pole to a place of security: if any one of them be loosed but for a moment, he bursts away, and flees into the woods like a tiger, leaving his pursuers behind. They are untameable, either by stripes or kindness; and, if they find no means of escaping from confinement, they commonly refuse sustenance, and die of hunger.

The injuries occasionally done to the settlers by these savages have excited the attention of Government, who have passed a decisive law against them. A proclamation has been issued by the Prince Regent, in which they are invited to live in villages, and become Christians, under a promise that, if they come to terms of peace and amity with the Portugueze, their rights shall be acknowledged, and they shall enjoy, in common with other subjects, the protection of the state; but, if they persist in their barbarous and inhuman practices, the soldiers of His Royal Highness are ordered to carry on a war of extermination against them. Those who are taken prisoners are at the disposal of their captors, as slaves, for the space of ten

years. It is doubtful whether the offers of conciliation contained in this proclamation will produce in any degree the desired effect; for the Bootocoodies have an unconquerable aversion to a settled way of life, and a rooted antipathy to every other nation; nor have they intelligence enough to appreciate the benefits of civilized society; so that there appears no hope of reducing them but by the dreadful alternative proposed in the latter part of the decree. One reason for having recourse to this summary mode of dealing with them, which will probably outweigh any arguments in favour of gentler proceedings, is, that the country they inhabit contains gold, and the settlers and adventurers are desirous to obtain speedy possession of it. Some officers, well acquainted with the locality of the territory, and skilled in the art of conducting an Indian war, are already employed in this difficult enterprize. About two leagues from this village is another called Piranga, situated near the margin of a river of that name, which at a distance of four leagues joins the San José, and with it forms the Rio Docé. This river runs through a fine country, in a northerly and afterwards an easterly direction, discharging itself into the sea in lat. $19^{\circ} 30'$ south. There are three islands at its mouth, called *Os Tres Irmanos*, (the Three Brothers).

Were this river rendered navigable, what benefits might accrue to the fine country through which it flows! Large quantities of sugar, cotton, and other produce, which the soil is capable of growing, besides excellent timber for exportation, would then form the basis of an extensive commerce, by stimulating the industry of the planters, who are at present averse from cultivating beyond the extent of their own consumption, on account of the heavy expence attendant on a land-carriage of above five hundred miles to the nearest sea-port.

Piranga is perhaps more exposed to the attacks of the Indians than the village of San José, but there are some gold-washings in its neighbourhood which tempt the inhabitants to brave that danger. A small band of horse-soldiers is stationed here to parade the confines, enter the woods, and go in quest of the savages whenever in-

formation is given. Yet, notwithstanding these precautions, the village is never in perfect security ; a house in its immediate vicinity was surprised a few months previous to our visit to this district.

We now took leave of the vicar and his guests, and, I may add, of all the villagers, who came out to salute us as we passed. Returning to Castro, I remained the whole of the next day to examine the establishment. It is built, like that at Barro, in the form of a square, the dwellings of the negroes forming three sides, and the mansion the fourth, the entrance being in front through a pair of gates which, when shut, secure the whole. The rooms in the mansion were like ancient halls, adorned with carvings, and fitted up and furnished after the old fashion. Here were blunderbusses, swords, and other weapons for defence, used in former days, when the house was liable to the continual attacks of the Bootocoodies. The stairs, gallery, and floors were of fine wood, of a quality which time had not in any degree perceptibly injured. Attached to the house were the remains of a sugar-mill, distil-house, corn-mill, and a machine, worked by a strap and spindles, for spinning cotton, all in a state of neglect. The whole establishment bore marks of former opulence and grandeur, from which it appeared to have gradually declined as the gold-washings at the confluence of the rivers and in other parts had become exhausted. The negroes were now all removed to Barro, except a few infirm and sick, who were stationed here to keep the mansion in order, (this being considered as a light employment for them,) until such time as their convalescence should fit them for resuming their labours along with their brethren at the other estate.

Having made a sketch of the house, and visited every part which interested me, I returned by the same road to Barro, where I employed myself in making a topographical map of the river, distinguishing by different colours the places already washed for gold, those which were then washing, and the yet unworked grounds. This sort of map might be made on a large scale, so as to include a whole

district or parish, where the several mines, or gold-beds, in their different stages, might be exhibited at one view.

On this estate are employed one hundred and fifty-six negroes, of all descriptions, who, on such excellent land, producing every necessary for food and clothing, might be expected to earn considerably more than their own maintenance; yet a former steward managed so ill for twenty successive years, that, although he had nothing to purchase but a little iron, and though the gold-mines were then more productive than at present, he ran the establishment annually into debt to the shopkeepers of Villa Rica. A single circumstance may account for this mismanagement; — the noble proprietor resided in Portugal. At present the estate is in a much more prosperous way, being entrusted to the care of another steward, and three overseers, all Creolians. The latter receive a salary of thirty milrees (about nine pounds sterling) per annum, besides their maintenance; their business is to execute the orders of the steward, and to superintend the labour of the negroes committed to their charge. They lead a life of extreme indolence, never putting their hands to any species of work.

The general diet of the country-people in this land of Canaan is somewhat similar to that of the miners in the vicinity of St. Paul's, already described. The master, his steward, and the overseers, sit down to a breakfast of kidney-beans of a black colour, boiled, which they mix with the flour of Indian corn, and eat with a little dry pork fried or boiled. The dinner generally consists, also, of a bit of pork or bacon boiled, the water from which is poured upon a dish of the flour above-mentioned, thus forming a stiff pudding. A large quantity (about half a peck) of this food is poured in a heap on the table, and a great dish of boiled beans is set upon it: each person helps himself in the readiest way, there being only one knife, which is very often dispensed with. A plate or two of colewort or cabbage-leaves complete the repast. The food is commonly served up in the earthen vessels used for cooking it; sometimes on pewter dishes. The general

beverage is water. At supper nothing is seen but large quantities of boiled greens, with a little bit of poor bacon to flavour them. On any festive occasion, or when strangers appear, the dinner or supper is improved by the addition of a stewed fowl.

The food prepared for the negroes is Indian corn-flour, mixed with hot water, in which a bit of pork has been boiled. This dish serves both for breakfast and supper. Their dinner consists of beans boiled in the same way. This unfortunate race of men are here treated with great kindness and humanity, which, indeed, their good behaviour seems to deserve. They are allowed as much land as they can, at their leisure, cultivate, (Sundays and holidays being by law allotted to them for that purpose,) and are permitted to sell or dispose of their produce as they please. Their owners clothe them with shirts and trowsers made of coarse cotton, which is grown and woven on the estate. Their days of labour are rather long: before sun-rise a bell rings to summon them to prayers, which are recited by one of the overseers, and repeated by the congregation; after worship is over they proceed to work, at which they continue till after sun-set, when prayers are said as in the morning. An hour after supper they are employed in preparing wood to burn, taking Indian corn from the husk, and in other in-door operations. Swelled necks are not uncommon among the men-negroes, but in other respects they appear healthy: I saw few or none afflicted with elephantiasis, or with any cutaneous disease. There were many very aged of both sexes; a few could even remember their old master, the first possessor, though he has been dead upwards of sixty years.

Their principal article of diet, the *farinha de melho*, or flour of Indian corn, appeared so palatable and nutritive, that, after living upon it for some time, I had the curiosity to inquire into the mode of preparing it from the grain. It is first soaked in water, and afterwards pounded in its swelled and moist state, to separate the outer husk. It then appears almost granulated, and is put upon copper pans, which have a fire underneath, and in these it is kept constantly

stirred until it is dry and fit for eating. This substitute for bread is as common among the inhabitants here as is the farinha de Pão or mandioca among the people of Rio de Janeiro, St. Paul's, and other districts.

The grain is grown always on virgin lands, cleared by burning, after the manner already described. In good seasons, or, in other words, when the dry weather allows the felled wood to be completely reduced to ashes, the return is from one hundred and fifty to two hundred bushels for one. Weeding is only performed after the seed has been a short time in the ground ; indeed, the growing crops suffer less from the neglect of that operation than from the depredations of rats, which are frequently very considerable.

On the state of society here I had little leisure to make observations. A general debility seemed to prevail among the females, which I imputed to the want of better food and more exercise : they confine themselves principally to the sedentary employments of sewing, or making lace. While at St. José I saw many females from the country, dressed in gowns made of English prints ; some of them had woollen mantles, edged with gold lace or Manchester velvet, thrown loosely over their shoulders. Their hair was invariably fastened with combs, and they in general wore men's hats. The men, most of whom belonged to the militia, appeared in uniforms. No two things can be more different than the deshabelle and full-dress of a nominal militia officer. When at home he seldom puts on more than half his clothes, over which he throws an old great coat ; and saunters about the house in this attire from morning till night, a true picture of idleness. On Sundays, or on gala-days, after some hours spent in decorating his person, he sallies forth, completely metamorphosed from a slip-shod sloven into a spruce officer, glittering in a weight of gold lace, on a horse caparisoned with equal splendor, forming as fine a sight for the gazing multitude as a general at a review. He observes no medium between these extremes, being always very shabby or very fine.

During my stay at Barro I was presented with some singularly fine fruit, equal in flavour to fresh almonds, and capable of being preserved by drying only, so as to become a valuable article of commerce. Having never before heard of this fruit, I am induced to give a brief account of it. The exterior substance is about the size of a full-grown cocoa-nut with the rind on, say nine or ten inches long and five or six in the thickest part. It grows suspended from the branch by a very slender but strong stem. This shell is full of kernels, to the number of from thirty to fifty, of the shape of almonds, but twice or thrice the size, disposed in ranges or layers and separated from each other by a white pithy substance. As these kernels ripen, the top of the shell, which appears like a lid, is gradually forced open, and when they are at full maturity, the larger part, which contains them, separates and falls to the ground. The trees, at the season of shedding their fruits, are frequented by wild hogs, herds of monkies, flocks of parrots, and other birds, which never quit them while any of these delicious nuts remain. I was credibly informed that some trees have been known to produce above a ton weight in a season. One of the nuts I preserved and brought with me, which I sent to that enlightened philosopher and eminent naturalist Sir Joseph Banks.

We now took leave of the good people at the fazenda, and returned to Villa Rica by the way we came. I had, with great difficulty, procured a quantity of butter, made after the new process, as a present for Mr. Lucas, the Judge, which arrived perfectly fresh and sweet. On passing Lavras Velhas, as we returned, we were shewn some excellent cinchona, very like that of Peru, and said to possess similar properties in a high degree. From the specimen we saw, there was every reason to believe, that, if fairly introduced into practice; it might be administered in many cases with as much success as Peruvian bark; and, as great quantities of it might be procured here, the experiment is certainly worth attending to by

medical men. I sent a parcel of it home, but by some accident or other it was lost in the Custom-house.

In many parts of our route we might have collected insects, but they require so much attention and care in preserving them for conveyance so great a distance, that I gave up the pursuit. It appeared to me extraordinary, that I had not, since my arrival in Brazil, seen (except in the cabinets of the curious) more than one diamond-beetle, though I had frequently searched for them in almost every variety of plantation.

During my absence from Villa Rica one of my soldiers had procured me a full pound of native bismuth in lumps, none of which exceeded an ounce in weight. It is frequently found in this state covered with a yellow oxide, which proves that it is out of its place, as it originally occurs in veins. Many pieces of pyrites, and various iron ores, were also brought me.

I had commissioned some persons to collect land shells for me during my absence, and was now to my great gratification presented with six, of a fine chesnut brown colour, with beautiful pink mouths, belonging to a new variety of the helix. Having kept them a few days, without taking out the animals, I was surprised to find that one of the latter had laid two eggs. I had not before imagined that they were oviparous. I took one of the shells in my hand, while the animal was crawling, when it immediately folded itself, and entered very quickly, in which exertion another egg was deposited in the mouth of the shell. All the eggs were about the size of a sparrow's. These were the only land shells I had seen on this journey.

On resuming my visit to the mint I took an early opportunity of stating to the acting governors my ideas respecting a new regulation for supplying mercury to the miners. One great impediment to the use of that metal, so essential in certain branches of the process, was the exorbitant price at which it was exclusively sold by the apothecaries, generally upwards of two shillings the ounce. I suggested

that the mint should be the general depository for it, and that it should be issued from thence to the gold-washers without profit. By this regulation the article would be brought into general use, much to the benefit of the state as well as of private individuals. I also gave them models of earthen vessels, which might be made at small expence, for evaporating and condensing the mercury, which, if universally adopted, would effect a great saving in the consumption of that article.

The remainder of my stay, previous to my journey to Tejuco, passed very agreeably. In the evening parties to which I was invited, and which generally consisted of ladies and gentlemen, I observed that the English style of dress prevailed, particularly among the former. The houses of the higher classes in Villa Rica are much more convenient and better furnished than any I saw in Rio de Janeiro and St. Paul's, and are for the most part kept in the exactest order. Their beds seemed to me so elegant as to deserve a particular description. The posts were of fine wood, fluted or carved in various ways; the sides plain, the bottoms of boards or leather. The bed itself was of cotton, the sheets of fine linen edged with lace of home manufacture, full nine inches broad. The bolster was covered with fine muslin, the ends of which were edged also with lace. The pillows were made round at the ends and covered with pink sarsnet, over which was another cover of fine muslin; terminated with broad lace, which being starched and delicately managed had a very rich appearance. The coverlet was yellow satin of a Damask pattern, edged like the sheets and pillows with broad lace. The hangings were of the same materials, in the form of a canopy, without curtains. Not excepting the refinements of recent date in this article of furniture, I never saw beds so magnificent as those of the opulent in this captaincy.

Every thing being now in readiness for my departure, I waited upon the several inhabitants to whom I had been introduced to express my thanks for the polite attentions they had shewn me, and

received from them the most obliging assurances of friendship and the kindest wishes for my welfare. I also, much to my regret, took leave of my valued friend and fellow-traveller Mr. Goodall, whose affairs required him to go to St. João del-Rey, and thence return to Rio de Janeiro. Never was a traveller more fortunate in a companion; always cheerful and in spirits, he had the happy faculty of regarding every thing on its bright side, and in all the various inconveniences of bad roads, wretched inns, miserable fare, and worse accommodations, he exemplified the truth of the adage that "a merry heart hath a continual feast." Being perfectly master of the language, and well acquainted with the character and manners of the people, he made himself at home every where, and generally contrived to draw from the conversation of those around him some topic either for lively remark or instructive comment. These amiable qualities, the offspring of a cultivated understanding and an excellent heart, gave him a double claim to that respect and confidence which we ever entertain for those whom we distinguish by the name of friend.

CHAP. XII.

Journey from Villa Rica to Tejuco, the Capital of the Diamond District.

HAVING previously sent letters to His Excellency the Condé de Linhares, giving him an account of my proceedings, I set out from Villa Rica, attended by the two soldiers and my negro servant. I passed through the city of Mariana, and entered upon the plain in its vicinity already mentioned, which in the rainy season is often entirely overflowed. To the left I observed a beautiful and romantic mountain called Moro de Santa Ana, on which stood many small neat houses, surrounded by coffee-plantations and orangeries; its base was watered by a corvinha or rivulet, the banks of which contain much gold, and are worked by the inhabitants of the mount. Passing onward, the road became very confined; and the land, though now covered with wood, appeared to have been formerly under cultivation. We here met a number of mules laden with sugar, destined for Villa Rica, or if not sold there, for Rio de Janeiro.

We arrived and refreshed at a little village called Camargo, and passed an excellent house, situated near a rivulet of that name, where there is a gold-washing which employs about two hundred negroes, and is said to be very productive. About a league farther we passed a poor little place called Bento Rodrigo, and about six in the evening arrived at a very considerable village called Infectionado, which contains full fifteen hundred inhabitants. It had been more populous, but its mines having decreased it was then on the decline. Finding no inn that offered any thing tolerable, I alighted at the house of a shopkeeper, who very civilly provided me an apartment to sleep in, and introduced me at supper to his wife and

three other ladies, whose society was very pleasant and cheerful. On the next day, after some trouble, my soldiers at a late hour procured mules, when I set out about ten o'clock upon a bad road, and after travelling half a league arrived at the Corgo de Infectionado, a fine rivulet flowing through a country rich in gold, particularly near the village of Santa Barbara, where washings appear in all directions. From hence to the village of Catos Altos, two leagues distant, is a tract of the finest open country I ever travelled in Brazil; it has many features resembling that between Matlock and Derby, and its mountains bear a strong similarity to those of Westmoreland. There are slips in some of them in which topazes are found, but rarely any of good quality. This district appeared equally suited for mining and agriculture, the ground being rich above as well as below. The village of Catos Altos, through which we rode, contains at least two thousand inhabitants, and is situated in a populous neighbourhood. The public buildings are well constructed, and the private houses in general appear very respectable, but bear evident marks of decay. We crossed the river, which is broad but shallow, and has works on its banks of greater extent and under better management than any I had hitherto seen. The whole vicinity is irrigated by numerous rivulets, many of which are diverted from their courses to a great distance for the purpose of gold-washing. In all parts, even on the tops and sides of the hills, we observed operations of this kind going on; in the valleys there were many spots still rich in gold, which had not yet been washed.

Continuing about six miles over this naked country, we entered on a more confined road, and passing a village called Cocaes, proceeded half a league further in the dark, to the mansion of Senhor Felicia, the Captain Mor of the district, where we alighted, having travelled this day above thirty miles. On being announced I was immediately shewn up stairs into a suite of handsome apartments, furnished with great magnificence, where I was introduced by the Captain to his amiable lady and daughter. We were joined by

Dr. Gomedez, a man of talents and science, with whom I entered into conversation, and who afterwards shewed me a fine collection of gold in various forms, some like duck-shot, others laminated with micaceous iron, others arborescent. He had also some specimens of stalactitic matter, on which nitre was forming, others of specular iron ore, and three or four fine pieces of chrome, which I at first took for realgar. From this gentleman I received considerable information respecting the mineralogy of the country, which is so difficult to be obtained accurate, that I found reason to reject all which did not correspond with what I saw. In the course of the evening the party was joined by the Count de Engenhausen, who commands a corps of cavalry in the district. He made many enquiries of me respecting England, that being the country in which he had received his education, and to which he seemed as much attached as to his native soil.

This large establishment, though still rich in gold, is worked by only two hundred negroes. One part of the estate is an auriferous mountain of schistus, containing beds of micaceous iron ore; the latter substance forms a thin stratum, which contains gold in grains laminated with it. It is singular to remark, that the *casalhão*, which generally, nay almost invariably, occurs in ravines and low situations is here found at a very small depth below the summit.

The discovery of the original gold-mine in this rich *sesmaria* is said to have been owing to the following accident. Some negroes employed in clearing the land, broke up an ant-hill of considerable size, when on laying it open to the air, for the purpose of destroying or dispersing the insects, large grains of gold were found. It is, however, highly probable that the general characteristics of the soil had led to the discovery long before this period, and that the accident here related served only to indicate the presence of gold in a part which had not been supposed to contain any. The estate is situated almost in the centre of the mining country, and is reputed one of the richest portions of it. The owner and his brother, who

are partners, have conducted their concerns in a liberal way, and are said to be very wealthy. It was my wish to have staid a day or two for the purpose of inspecting the extensive works which they have opened; but I forbore to make any request of this nature, as I perceived, or supposed, some little jealousy or suspicion respecting my views. It seemed to be the opinion here, as well as in other places, that I had a mission from Government, authorizing me to enquire into the state of the mines, and give a report concerning them.

In riding past the works, after having taken leave of the captain, I did not perceive any machinery used for facilitating manual labour. The tedious process of washing by hand was most generally practised; in some instances inclined canoes were used, which, if carried to the degree of improvement of which they are susceptible, might much more effectually answer the purpose.

Between the mountain on Captain Felicia's estate and the village of Sabara is a rich mining district, which extends also to Bromare, over a continuation of hilly country. It is occupied by several opulent miners, who possess many fine grounds still unworked. A tract of land a few miles in extent is appropriated to agricultural purposes, being reputed to be destitute of gold.

I proceeded four leagues, over a well-watered and finely-wooded country, to a hamlet called Vas, a name which had become familiar to my ear through the frequent mention which my soldiers made of "the good old man of Vas." This person, whose reception of me fully justified the appellation with which he had been distinguished, was a farmer from Oporto, who had been resident here about forty years. He bought the estate with twenty negroes upon it, and paid for it by yearly instalments in twenty years afterwards. This mode of disposing of estates is much practised, being at once easy to the purchaser, and advantageous to the seller, as it ensures to the latter a better price than he could obtain on the condition of immediate payment. The house, which is well-built and convenient, has a sugar-mill and distillery attached to it. The sugar is generally sent

to Rio, under an agreement with the carrier, giving him half or sometimes two-thirds of the proceeds, with a promise of back-carriage of salt, iron, and other commodities.

Owing to the kind assiduities of my worthy host, the evening passed very agreeably. Many of the neighbours came to see and converse with me, as I was the first Englishman, or perhaps foreigner, who had ever travelled so far into the interior. Their curiosity led them to examine almost every implement I carried with me; my saddle, bridle, and stirrups were viewed with great attention; nor could they imagine how it was possible to sit in the former with any degree of safety. There was no convincing them that it was much preferable to the Portugueze saddle, which has a ridge about eight inches high, both before and behind, so that the rider is, as it were, in the stocks, and, though not so liable to be thrown out, has a most galling and uncomfortable seat.

The next morning I visited the negroes' houses, and was much pleased to find one set apart for the reception of poor and distressed travelling negroes, who here find a fatherly protection, and are allowed to stay as long a time as may suit their necessities. On taking leave of the good old gentleman, I could not prevail on him to accept any remuneration for his kindness, and he replied to my thanks with the warmest assurances of welcome. I crossed a fine stream, and rode through several plantations of sugar-cane, which were at this season nearly ready for cutting. The country, as we proceeded, gradually became more mountainous, and abounded with argillaceous schistus very full of quartz. After riding about sixteen miles, we saw a very singular mountain, or bare rock of granite, called Itambè, forming part of a high ridge which lay on our left. About four o'clock we arrived at a poor village, also called Itambè, situated near a fine river of the same name. This place was formerly of some consequence, but as the gold in its vicinity failed, it sunk into poverty and wretchedness. It contains about a thousand inhabitants, who, degraded to the lowest stage of inactive apathy, looked as if they were

the ghosts of their progenitors haunting the ruins of their departed wealth.

Every thing about them bore a cheerless aspect ; the houses were ready to fall to the ground through want of repair ; the door-places were overgrown with grass, and the patches of garden-ground that here and there appeared were covered with weeds. The face of the country, too, was entirely different from that which I had passed on my way hither, being universally sterile, dry, and stony. It may well be supposed, from this description, that our accommodations here were of the worst kind : we halted at a miserable abode, where they offered us some mouldy Indian corn and feijones, and, after a great deal of difficulty, procured us a fowl. My servant was obliged to clean all the utensils before they could be used ; and the soldiers, while cooking, were obliged to guard the pot lest some half-famished prowler should steal it. The commandant of the place, with whom we had afterwards some conversation, answered our remarks on the visible signs of starvation in the looks of the villagers, by coolly saying, “ While they get Indian corn to eat, and water to drink, they will not die of hunger.” I was glad to depart from this home of famine as fast as possible, heartily joining in the exclamation which the Portugueze have bestowed upon it : “ De las miserias de Itambè Senhor nos libre,” — (From the miseries of Itambè the Lord deliver us !)

After riding about five miles, we came to the River of Ounces, so named from the numbers of those animals which formerly infested its banks. Changing our mules at a village called Lagos, consisting of a few miserable fazendas, we proceeded a league over a most rugged and mountainous road, and passing a ridge, entered on a fine country, presenting to view a grand picturesque mountain nearly a league distant from us ; about mid-way up was a large house, to which we directed our course. We forded a rather deep river called Rio Negro, on account of the blackness of its waters, caused by the decomposition of bituminous or vegetable matter. Its margin, along

which we rode for some distance, presented some fine grazing land. Passing through a broken and irregular tract of country, we arrived at another deserted village called Gaspar Suares, and rode up to the house above-mentioned, the owner of which was from home, but his lady received me very politely. Having arrived rather early in the evening, I employed myself some time in walking about the grounds: the mountain on which the house stands consists almost entirely of micaceous iron ore*; the wall before the door of the house was built of that substance. In some parts, to my great surprise, I observed it lying in regular strata, not more than an inch in thickness, between beds of white sand. The quantity of ore found in this neighbourhood is so considerable as to have induced Government to commence an iron-work, under the direction of Mr. Fernando de Camara, Intendant of the Diamond District. In aid of this undertaking, the gentleman, at whose house I was a guest, has presented a square league of wood-land, the only tract of that description in the neighbourhood. The ground for the intended works is marked out, and a few blocks of stone are prepared; but the undertaking seems to go on very slowly, and probably will not arrive at any great degree of perfection.

This hill and the streams near it were formerly rich in gold, but they have been completely washed, and are at present as much exhausted as the works at Itambè. A rivulet which runs over the top of the hill afforded conveniences for washing, which are very rarely to be met with; it is now intended to be converted to the use of the iron manufactory.

On the following day I continued my route northerly, over a fine country, and, after riding, or rather walking, about six miles of bad road with wretched mules, ascended a hill abounding with rich compact iron ore. Two leagues of the way were covered with excellent

* This substance contains fine-formed octaëdral crystals of magnetic iron.

oxide of iron, and it appeared as if the hills were entirely covered with that substance. Without any material occurrence, we arrived at a beautiful rivulet, near which stood a miserable hut, where two women were weaving cotton. This place, apparently so insignificant, proved one of the most interesting, in a mineralogical point of view, which I had hitherto visited. It is called Largos, and also bears the name of Oro Branco (White Gold), in allusion to a granular substance, not unlike gold in size and weight, found in a gold-washing in the bed of the stream. This substance, which has since been proved to be platina, was discovered many years ago in the cascalhão below the vegetable earth, and incumbent on the solid rock, accompanied with gold and black oxide of iron. From these circumstances the people judged it to be gold united with some other metal, from which it could not be separated; and, as the quantity of real gold found was small, and the white gold, as they called it, was not known to be of value, the work was gradually neglected, and at length abandoned. I procured a specimen of the substance: it appeared accompanied with osmium and iridium, and was in rougher grains than the platina brought from the province of Choco; which latter circumstance may be owing to its not having been triturated with mercury. Now that the substance is known to be platina, it is doubtful whether the work might be resumed with advantage, as the demand for that article is at present so small, that the quantity sold would hardly pay expences. Near this place is a work called Mata Cavalhos.

The rivulet of Largos empties itself into the Rio de St. Antonio, along which we rode a small distance, and, proceeding about four miles farther, arrived at Conceção, a large and tolerably handsome village. I was conducted to the house of the curate, who kindly assigned to me an apartment for the night, and, perceiving that I was unwell, gave me an invitation to rest a day, which I very gladly accepted.

I here received many visits from the villagers, whose curiosity had been excited by the news of an Englishman having arrived: some of

them were upwards of eighty years of age, and, as they had resided here more than fifty, they were able to give many curious accounts of the country, and of the progress and decline of its mines. I was much pleased with the information they communicated, but more so with the attention of the good curate, who corrected every misrepresentation, and seemed anxious that I should not be led into error, either through accident or design. By some means or other, an opinion circulated among them that I was a physician, and numbers of infirm persons, principally old men, women, and children, were brought to me for advice. In the evening we were entertained with music by some of the younger females, who brought their guitars, and sung several pleasing airs.

I was here shewn a Bootocody Indian boy, apparently about nine years of age, who had been taken about six months before. He could not utter a word of Portuguese; but, from the expression of his countenance, he seemed capable of being taught any thing. His eyes had so much vivacity in them that they almost spoke, especially when his attention was attracted by any thing agreeable, as I found by offering him a few sweetmeats, with which he seemed much delighted. I examined his features and the construction of his frame with some curiosity, as exhibiting the characteristics of the singular race of men from whom he sprung. The face was short, the mouth rather wide, the nose broad, the eyes large and black, skin of a dusky copper-colour, hair jet black, strong, straight, and of regular length, limbs stout and well-proportioned, feet large, probably from going without shoes. He lived with a poor woman, who clothed and brought him up exactly as one of her family. On enquiring how he came there, I was informed that he belonged to a party of Indians who were surprised at a place about six leagues distant, and all either fell or escaped, except this little fellow, who was taken care of, and brought hither by an officer resident in the village.

Being still too unwell to travel, I remained another day, and met with every attention and care from the good clergyman and his

housekeeper. In the course of conversation, he informed me that he studied and had been ordained at St. Paul's ; and when he learnt that I had been there so recently, seemed much pleased, and asked me many questions respecting the present state of that city, which shewed his attachment to it as the scene of his youthful days.

About a week previous to my arrival, this village was the scene of a somewhat remarkable adventure. A *tropero** going to Rio de Janeiro with some loaded mules, was overtaken by two cavalry soldiers, who ordered him to surrender his fowling-piece ; which being done, they bored the butt-end with a gimblet, and finding it hollow, took off the iron from the end, where they found a cavity containing about three hundred carats of diamonds, which they immediately seized. The man in vain protested his innocence, stating that he had bought the gun of a friend : he was hurried away, and thrown into prison at Tejuco, where I afterwards saw him. The diamonds were confiscated, and the soldiers received half their value. The fate of this man is a dreadful instance of the rigour of the existing laws : he will forfeit all his property, and be confined, probably, for the remainder of his days in a loathsome prison, among felons and murderers. What must be the feelings (if, indeed, he can be said to possess any) of the man who betrayed him ; for, doubtless, the poor fellow owed his misfortune to some secret villain, in the shape of a confidential friend, who, having learned his mode of carrying diamonds concealed, had, for the sake of a paltry premium, or from some mean-spirited motive, given notice of it to Government ! How must the miscreant recoil at having brought to irreparable ruin, and plunged into that lowest state of human misery, perpetual imprisonment, a man who not only claimed his sympathy as a fellow-creature, but was united to him by the ties of friendship !

* An owner of mules, who travels with a number of them, carrying goods for other persons, as well as on his own account.

The village of Concepção seemed to me large enough to contain two thousand inhabitants, but, like most others in this exhausted district, it was fast hastening to decay. The rent of a tolerable house is about two shillings a month. The only manufacture carried on here is that of a little cotton, which is spun by the hand, and woven into coarse shirting. It appears to be a maxim among the inhabitants rather to go naked, than labour to clothe themselves. The vestiges of old gold-washings in every direction, and the slight quantities still found in all parts, from the summits of the mountains to their bases, might almost lead a traveller to conclude that the whole country was at one period auriferous. The surface is in general fine red earth, and in many parts presents fine situations for iron-works, as there is ore and wood in abundance. It is much to be wished that such works were established; for iron is so dear at Concepção, and the people in general so poor, that the mules have seldom a shoe to their feet, which is irksome to the riders, and dangerous to the animals themselves, as they are continually coming down, particularly when ascending a clay-hill, after a shower of rain.

Neither here, nor in any other part of my journey from Villa Rica, did I observe any limestone, though I was informed that considerable quantities were found near Sabara.

Taking leave of the worthy curate, I set out for Tapinha-canga*, distant about thirty miles. After an unpleasant ride through a rough stony country, abounding in quartz laminated with schistus, I reached a village called Corvos, where there are some gold-washings, one of which produced, about half a year ago, a net profit of 800*l.*, though only four negroes were employed a month upon it. The road to the village above-mentioned led through a most uneven tract, presenting formidable precipices, which required us to travel with so much caution, that we did not complete our journey until an hour

* Canga is the name of ferruginous quartz, fragments of which abound in this town, and are used for paving the streets.

after sun-set. I was received into a very respectable house, which had the appearance of former opulence. The owner, Captain Bom Jarden, a venerable old gentleman, came to welcome me: on entering into conversation, he informed me that he had emigrated hither from Oporto at the age of seventeen, and had lived here sixty-two years. He was tempted to settle here by the hope of participating in the rich treasures for which the country was then famed; but he arrived two or three years too late: the mines were already on the decline, and he was obliged to turn his attention to agricultural pursuits, in which he persevered with such success that he was enabled to realize a comfortable independency, and to bring up a numerous family in credit and respectability. It had been well if his neighbours had profited by so eminent an example, instead of deserting the country when the gold on its surface disappeared. That many did so was evident from the declining state of the village; a great number of its houses were falling to decay, others were untenanted, and its population, which formerly amounted to near three thousand, was dwindled to a third of that amount.

Continuing my journey next day, I crossed the ridge of a lofty chain of mountains, abounding with streams, that were much swoln in consequence of the late rains; one of the largest, called Rio dos Peches, I forded thrice, and entered on a wide champaign country. In many parts I saw large tracts of bare places, where the grit-stone alternated with argillaceous schistus. The next ten miles led through an elevated and fertile plain, intersected with rivulets in every direction, and well calculated for farming, but very thinly inhabited. Early in the afternoon I reached an eminence, from which I had a fine view of Villa do Principe, situated on the rise of a lofty hill opposite, the base of which was washed by a rivulet called *Corvinha de Quatro Vengtems**. On arriving in the town, I was conducted to

* Four vengtems are nearly equal to a shilling of our money. When this rivulet was first washed for gold, the quantity produced by each gamella amounted in value to that sum. As

to the house of the governor, or chief magistrate, who received me very politely, and introduced me to his lady and a party of friends, with whom I took tea.

Villa do Principe was established as a comarco, or district, in the year 1730, when the gold-washings were most productive: but it dates its origin fifteen years earlier, at which period the place was discovered by the Paulistas, who had then commenced to migrate from Villa Rica and the adjacent settlements. The town at present contains about five thousand inhabitants, the most considerable proportion of whom are shopkeepers, and the rest artisans, farmers, miners, and labourers. Here is a house of permutation, to which every miner in the district brings the gold he obtains, and pays the royal fifth, as is done in Villa Rica. The ouvidor holds the office of mint-master, which renders his situation one of the best in the gift of the crown. Here are several inferior officers belonging to various departments of the public service. As this town is situated very near the confines of the Diamond District, and on the high road leading to it, the strictest regulations prevail respecting the passage of all persons thither. No one, except travellers on business, with certificates to that effect, is suffered to proceed, until a formal notification has been made to the governor of that district; the laws of which are so strict, that any person found within it, out of the regular road, is liable to be apprehended on suspicion, and subjected to an examination, which frequently occasions much trouble and delay.

The country around Villa do Principe is very fine and open, being free from those impenetrable woods, which occur so frequently in

the cascalhão then lay near the surface, and required very little trouble to get at, one washer could clear about twelve bowls-ful per hour, which was considered a comparatively rich return.

In the mines they have two methods of estimating the quantity produced: for example; Quatro Vengtems here mean four vengtems of gold, which is equal to eight of copper; whereas, in Rio de Janeiro, the same expression implies four vengtems of copper.

other parts of the province. Its soil is in general very productive, and the climate mild and salubrious.

At a washing about six leagues distant, a lump of gold was found of several pounds weight. From the same place I procured some above two ounces, and obtained the large crystals now in my possession, one of which is considered as unique.

I quitted Villa do Principe about noon on the day following, after making my acknowledgments for the polite attentions of the governor, who kindly sent a servant to attend me the first league of the road. This man I commissioned, under a promise of pecuniary recompence, to collect for me land-shells and insects, against my return, which I expected would take place in two or three months; and, from the aptness with which he received my directions, (joined to the prospect of emolument,) I had little doubt that he would attend to them.

As we journeyed on, I perceived that the country bore an aspect entirely different from that in the neighbourhood of Villa do Principe: its surface, consisting of coarse sand and rounded quartz pebbles, was almost destitute of wood or herbage. One hillock near the road exhibited perpendicular laminæ of micaceous grit, which, on alighting from my horse and examining, I found to be flexible. My soldier, hearing me remark that the country bore characteristics which I had never observed elsewhere, exclaimed, " Senhor, we are in the Diamond District." This circumstance, which I had not before thought of, fully accounted for the change. We travelled over a very sterile country for the first four leagues, and passed several high mountains. Towards the close of the day we reached an eminence, from which we beheld a most romantic cluster of dwellings, resembling a labyrinth, or a negroes-town in Africa. We descended the hill, and approached the place; when, it being nearly dark, I was conducted to a house much larger than any of the others, where I learnt that the establishment was a diamond-work called San Gonzales, the first which occurs in the Cerro do Frio. It has been some

time on the decline, and employs about 200 negroes. The intendant, a very intelligent man, had been apprised of our coming by a letter from the governor at Tejuco, and gave me a very friendly reception. While engaged in conversation with him, I observed (it being now moon-light) some fine cows in front of the premises, and concluded that they were come to be milked, but this I understood was not the case. They were licking the door-posts and sides of the houses with much apparent eagerness, and, on enquiring what this signified, I was told that they wanted salt. They were so tame and gentle that, on holding out my hand, they licked it; when, being desirous to see the effect which salt produced on them, I procured some, and gave them a handful: but they became so very unruly for more, that had I not immediately desisted and retired, their fury might have produced serious consequences.—This article is so necessary for the support of the cattle, that their very existence depends on it, yet it is encumbered with a heavier duty than any other article of import, iron alone excepted. Surely, when it is considered that vast herds are daily sent from this province to Rio de Janeiro, each paying a toll of nearly twelve shillings on crossing the river Paraibuna, the impolicy of this duty must be self-evident, because, in raising the price of the commodity to an excessive degree, it checks the breed of cattle, and thus ultimately defeats the purpose for which it was imposed.

The next day, before we left this romantic place, I devoted some time to an examination of the refuse-hillocks contiguous to the diamond works, but found nothing among the heaps of quartzose stones, which had been washed when this place was more in repute. I here noticed a thin stratum below the roots of the grass, which I had elsewhere seen, but never so distinctly characteristic. It is called *burgalhão*, and consists of quartz pebbles, generally angular, and not unfrequently large beds of solid quartz not more than four or five inches thick. This stratum does not appear to have been formed at the same time or by the same means as the *cascalhão*,

from which it is invariably separated by a stratum of vegetable earth unequal in thickness ; it has more the appearance of a thin bed of quartz subsequently shattered into innumerable fragments.

Having taken leave of the administrator, I proceeded through a continuation of mountainous and sterile country, very thinly inhabited. I stopt at one of the best of the few miserable houses on the road to procure some refreshment. There was a half-starved cat in the door-way, the sight of which plainly evinced to me what I had to expect. Poor animal, thought I, the habitation in which thou existest, will not afford maintenance for a mouse, much less for thee! While musing on this picture of distress and famine, a poor meagre woman came to the door, of whom I requested a little water, which she brought me, and while I was drinking it she began to implore charity. Her countenance had already expressed what her tongue now uttered : I gave her the few provisions my soldiers had with them, together with a small piece of money, and took leave ;—the last words I heard from her were those of gratitude.

Ere we arrived at this place, we had seen Tejuco at full twelve miles distance, and were now much nearer. We crossed two rapid rivulets, one of them called Rio Negro, the waters of which were of a very black colour, and afterwards passed a guard-house, or register, called Mielho Verde, situated near a stream of the same name, formerly much noted for diamonds. Here a band of soldiers are stationed, who are always on the alert, riding after and examining passengers. The country is extremely rough, and destitute of vegetation, covered in all directions with grit-stone rocks full of rounded quartzose pebbles. We rode two miles along the Corvinha de St. Francisco, which runs through the ravine at the foot of the mountain on the side of which Tejuco is built, presenting much the same appearance as Villa Rica. I entered the town, and took up my abode at the best inn, which contained some neat rooms, and afforded tolerable accommodations.

This was Sunday the 17th of September, being one month since my departure from Rio de Janeiro, during which time I had been almost continually on horseback ; for the time I remained at Villa Rica was principally occupied in journeys to various places in the neighbourhood.

CHAP. XIII.

Visit to the Diamond Works on the River Jigitonhonha. — General Description of the Works. — Mode of Washing. — Return to Tejuco. — Visit to the Treasury. — Excursion to Rio Pardo. — Miscellaneous Remarks.

THE continual fatigues, and want of accommodation on the journey, had rendered me very unwell, and I was therefore desirous of resting a week at Tejuco before I proceeded to the diamond mines; but, learning that I had been expected for the last two or three days, I sent one of my soldiers up to the house of Mr. Fernando de Camara, the governor, to announce my arrival, and to state that I was prevented by indisposition from personally paying my respects to him. He immediately came with a few friends to visit me, gave me a most hearty welcome to Tejuco, and staid with me at least three hours. I delivered to him my public and private letters, passports, and other credentials, which he perused with great satisfaction, observing to the Ouvidor and his friends, that I possessed the same privileges which they did, having permission from the court to see every place I wished, which they were directed to shew me. He then told me that, in expectation of my arrival, he had delayed a journey to the greatest of the diamond works, called Mandanga, situated on the river Jigitonhonha, which employs about a thousand negroes, and on particular occasions double that number. He was desirous that I should see this great work with all the machinery in operation, which would be very speedily removed, the late rains having swoln the river so much as to render working more, impracticable. He therefore kindly invited me to breakfast at his house on the following morning, when he would have all in readiness for a journey of about thirty miles to the place above-mentioned.

At an early hour I arose ; and, though so unwell as to be scarcely more than half alive, I could not resist the favourable opportunity now offered me of gratifying the curiosity which had so long occupied my mind, by visiting the diamond mines, in company with the principal officer in the administration of them, who was therefore qualified to furnish me with the amplest information. A fine horse was waiting for me at the door, and I rode up to the house of the governor, who introduced me to his amiable lady, daughters, and family, with whom I had the honour to take breakfast. Several officers of the diamond establishment arrived on horseback to accompany us, their presence being required on this occasion.

At nine o'clock we set out, and crossed the ravine, watered by the small rivulet of St. Francisco, which separates Tejuco from the opposite mountains. The road was very rough and uneven, continually ascending or descending mountains of considerable extent, the strata of which were grit alternating with micaceous schistus, and presenting an immense quantity of rude masses, composed of grit and rounded quartz, forming a loose and friable kind of pudding-stone. The country appeared almost destitute of wood; presenting occasionally a few poor shrubs; there were no cattle to be seen, yet some of the tracts would certainly maintain sheep in great numbers. Having halted at a place about half way, we descended a very steep mountain, full a mile in the declivity, and entered a ravine where we crossed a very good wooden bridge over the river Jigitonhonha, which is larger than the Derwent at Derby. We rode along its margin, where the land appears much richer, presenting a good vegetable soil covered with underwood; and, proceeding about a league, arrived at the famed place called Mandanga. The habitations, which are about one hundred in number, are built detached, and are generally of a circular form, with very high thatched roofs, like African huts, but much larger. The walls are formed of upright stakes, interwoven with small branches and coated with clay inside and out. The houses of the officers are of the

same materials but of much more convenient form, and white-washed within. Near some of the houses we observed inclosures for gardens, which, in some degree, enlivened the prospect, and gave an air of comfort to these rude and simple dwellings.

I remained here five days, during which I was occupied in viewing and examining various parts of the works, of which I shall here attempt to give a general description.

This rich river, formed by the junction of a number of streams which will be hereafter noted, is as wide as the Thames at Windsor, and in general from three to nine feet deep. The part now in working is a curve or elbow, from which the current is diverted into a canal cut across the tongue of land round which it winds, the river being stopped just below the head of the canal by an embankment formed of several thousand bags of sand. This is a work of considerable magnitude, and requires the co-operation of all the negroes to complete it; for, the river being wide and not very shallow, and also occasionally subject to overflows, they have to make the embankment so strong as to resist the pressure of the water, admitting it to rise four or five feet.

The deeper parts of the channel of the river are laid dry by means of large caissons or chain-pumps, worked by a water-wheel. The mud is then carried off, and the cascalhão is dug up and removed to a convenient place for washing. This labour was, until lately, performed by the negroes, who carried the cascalhão in gamellas on their heads, but Mr. Camara has formed two inclined planes about one hundred yards in length, along which carts are drawn by a large water-wheel, divided into two parts, the ladles or buckets of which are so constructed that the rotatory motion may be altered by changing the current of water from one side to the other; this wheel, by means of a rope made of untanned hides, works two carts, one of which descends empty on one inclined plane, while the other, loaded with cascalhão, is drawn to the top of the other, where it falls into a cradle, empties itself, and descends in its turn. At a work called Canjeca, formerly of great importance,

about a mile up the river on the opposite side, there are three cylindrical engines for drawing the *cascalhão*, like those used in the mining country of Derbyshire, and also rail-ways over some uneven ground. This was the first and only machinery of consequence which I saw in the diamond district, and there appear many obstacles to the general introduction of it. Timber, when wanted of large size, has to be fetched a distance of one hundred miles at a very heavy expence; there are few persons competent to the construction of machines, and the workmen dislike to make them, fearing that this is only part of a general plan for superseding manual labour.

The stratum of *cascalhão* consists of the same materials with that in the gold district. On many parts, by the edge of the river, are large conglomerate masses of rounded pebbles cemented by oxide of iron, which sometimes envelop gold and diamonds. They calculate on getting as much *cascalhão* in the dry season as will occupy all their hands during the months which are more subject to rain. When carried from the bed of the river whence it is dug, it is laid in heaps containing apparently from five to fifteen tons each.

Water is conveyed from a distance, and is distributed to the various parts of the works by means of aqueducts, constructed with great ingenuity and skill. The method of washing for diamonds at this place is as follows:—A shed is erected in the form of a parallelogram, twenty-five or thirty yards long and about fifteen wide, consisting of upright posts which support a roof thatched with long grass. Down the middle of the area of this shed a current of water is conveyed through a canal covered with strong planks, on which the *cascalhão* is laid two or three feet thick. On the other side of the area is a flooring of planks, from four to five yards long, imbedded in clay, extending the whole length of the shed, and having a slope from the canal, of three or four inches to a yard. This flooring is divided into about twenty compartments or troughs, each about three feet wide, by means of planks placed on their edge. The upper ends of all these troughs

Drawn by Altony from a sketch by J. H. Moore.



A View of the manners in which the bed of the River Saginaw
is laid dry by an Aqueduct in order to search for Diamonds.

H. F. Peck's engraving.



(here called canoes) communicate with the canal, and are so formed that water is admitted into them between two planks that are about an inch separate. Through this opening the current falls about six inches into the trough, and may be directed to any part of it, or stopped at pleasure by means of a small quantity of clay. For instance, sometimes water is required only from one corner of the aperture, then the remaining part is stopped; sometimes it is wanted from the centre, then the extremes are stopped; and sometimes only a gentle rill is wanted, then the clay is applied accordingly. Along the lower ends of the troughs a small channel is dug to carry off the water.

On the heap of cascalhāo, at equal distances, are placed three high chairs* for the officers or overseers. After they are seated, the negroes† enter the troughs, each provided with a rake of a peculiar form and short handle, with which he rakes into the trough about fifty or eighty pounds weight of cascalhāo. The water being then let in upon it, the cascalhāo is spread abroad and continually raked up to the head of the trough, so as to be kept in constant motion. This operation is performed for the space of a quarter of an hour; the water then begins to run clearer, having washed the earthy particles away, the gravel-like matter is raked up to the end of the trough; after the current flows away quite clear, the largest stones are thrown out, and afterwards those of inferior size, then the whole is examined with great care for diamonds‡. When a negro finds one, he immediately stands upright and claps his hands, then extends them,

* In order to insure the vigilance of the overseers, these chairs are constructed without backs or any other support on which a person can recline.

† The negroes employed in these works are the property of individuals, who let them to hire at the daily rate of three vengtems of gold, equal to about eight-pence, Government supplying them with victuals. Every officer of the establishment is allowed the privilege of having a certain number of negroes employed.

‡ The negroes are constantly attending to the cascalhāo from the very commencement of the washings, and frequently find diamonds before this last operation.

holding the gem between his fore-finger and thumb; an overseer receives it from him, and deposits it in a gamella or bowl, suspended from the centre of the structure, half full of water. In this vessel all the diamonds found in the course of the day are placed, and at the close of work are taken out and delivered to the principal officer, who, after they have been weighed, registers the particulars in a book kept for that purpose.

When a negro is so fortunate as to find a diamond of the weight of an octavo ($17\frac{1}{2}$ carats), much ceremony takes place; he is crowned with a wreath of flowers and carried in procession to the administrator, who gives him his freedom, by paying his owner for it. He also receives a present of new clothes, and is permitted to work on his own account. When a stone of eight or ten carats is found, the negro receives two new shirts, a complete new suit, with a hat and a handsome knife. For smaller stones of trivial amount proportionate premiums are given. During my stay at Tejuco a stone of $16\frac{1}{2}$ carats was found: it was pleasing to see the anxious desire manifested by the officers that it might prove heavy enough to entitle the poor negro to his freedom, and when on being delivered and weighed, it proved only a carat short of the requisite weight, all seemed to sympathize in his disappointment.

Many precautions are taken to prevent the negroes from embezzling diamonds. Although they work in a bent position, and consequently never know whether the overseers are watching them or not, yet it is easy for them to omit gathering any which they see, and to place them in a corner of the trough for the purpose of secreting them at leisure hours, to prevent which they are frequently changed while the operation is going on. A word of command being given by the overseers, they instantly move into each other's troughs, so that no opportunity of collusion can take place. If a negro be suspected of having swallowed a diamond, he is confined in a strong room until the fact can be ascertained. Formerly the punishment inflicted on a negro for smuggling diamonds was con-

fiscation of his person to the state : but it being thought too hard for the owner to suffer for the offence of his servant, the penalty has been commuted for personal imprisonment and chastisement. This is a much lighter punishment than that which their owners or any white man would suffer for a similar offence.

There is no particular regulation respecting the dress of the negroes : they work in the clothes most suitable to the nature of their employment, generally in a waistcoat and a pair of drawers, and not naked, as some travellers have stated. Their hours of labour are from a little before sun-rise until sun-set, half an hour being allowed for breakfast, and two hours at noon. While washing they change their posture as often as they please, which is very necessary, as the work requires them to place their feet on the edges of the trough, and to stoop considerably. This posture is particularly prejudicial to young growing negroes, as it renders them in-kneed. Four or five times during the day they all rest, when snuff, of which they are very fond, is given to them.

The negroes are formed into working parties, called troops, containing two hundred each, under the direction of an administrator and inferior officers. Each troop has a clergyman and a surgeon to attend it. With respect to the subsistence of the negroes, although the present governor has in some degree improved it by allowing a daily portion of fresh beef, which was not allowed by his predecessors, yet I am sorry to observe that it is still poor and scanty ; and in other respects they are more hardly dealt with than those of any other establishment which I visited : notwithstanding this, the owners are all anxious to get their negroes into the service, doubtless from sinister motives, of which more will be said hereafter.

The officers are liberally paid, and live in a style of considerable elegance, which a stranger would not be led to expect in so remote a place. Our tables were daily covered with a profusion of excellent viands, served up on fine Wedgewood ware, and the state of their household generally corresponded with this essential part of it.

They were ever ready to assist me in my examination of the works, and freely gave me all the necessary information respecting them.

Having detailed the process of washing for diamonds, I proceed to a general description of the situations in which they are found. The flat pieces of ground on each side the river are equally rich throughout their extent, and hence the officers are enabled to calculate the value of an unworked place by comparison with the amount found on working in the part adjoining. These known places are left in reserve, and trial is made of more uncertain grounds. The following observation I often heard from the intendant: "That piece of ground" (speaking of an unworked flat by the side of the river) "will yield me ten thousand carats of diamonds whenever we shall be required to get them in the regular course of working, or when, on any particular occasion, an order from Government arrives, demanding an extraordinary and immediate supply."

The substances accompanying diamonds, and considered good indications of them, are bright bean-like iron ore, a slaty flint-like substance, approaching Lydian stone, of fine texture, black oxide of iron in great quantities, rounded bits of blue quartz, yellow crystal, and other materials entirely different from any thing known to be produced in the adjacent mountains. Diamonds are by no means peculiar to the beds of rivers or deep ravines; they have been found in cavities and water-courses on the summits of the most lofty mountains.

I had some conversation with the officers respecting the matrix of the diamond, not a vestige of which could I trace. They informed me that they often found diamonds cemented in pudding-stone, accompanied with grains of gold, but that they always broke them out, as they could not enter them in the treasury, or weigh them with matter adhering to them. I obtained a mass of pudding-stone, apparently of very recent formation, cemented by ferruginous matter enveloping many grains of gold; and likewise a few pounds weight of the *cascalhão* in its unwashed state.

This river, and other streams in its vicinity, have been in washing many years, and have produced great quantities of diamonds, which have ever been reputed of the finest quality. They vary in size ; some are so small that four or five are required to weigh one grain, consequently sixteen or twenty to the carat : there are seldom found more than two or three stones of from seventeen to twenty carats in the course of a year, and not once in two years is there found throughout the whole washings a stone of thirty carats. During the five days I was here they were not very successful ; the whole quantity found amounted only to forty, the largest of which was only four carats, and of a light green colour.

From the great quantity of debris, or worked cascalhão, in every part near the river, it is reasonable to calculate that the works have been in operation above forty years ; of course there must arrive a period at which they will be exhausted, but there are grounds in the neighbourhood, particularly in the Cerro de St. Antonio, and in the country now inhabited by the Indians, which will probably afford these gems in equal abundance.

After residing here five days, we visited a diamond work called Montero, about two miles up the river, and went a league further to a gold-work called Carapata. The cascalhão at this work was taken from a part of the river eight feet deep, which formed an eddy under a projecting point ; I was shewn a heap of it, that was estimated to be worth 10,000l. In removing this heap from its bed, four hundred negroes had been employed three months ; and to wash it, would occupy one hundred men for three months more, the expence of both operations amounting to perhaps 1,500l. We arrived at this place at eight o'clock in the morning ; six negroes were employed four hours in washing two troughs, containing together about a ton of cascalhão, when, to my great surprise, after the water ran clear, and the large stones were thrown out, the black oxide of iron, of which there was great abundance, was fringed with grains of gold, a novel and very agreeable sight to a stranger. The gold was taken

out at three or four different times, and, when the washing was completed, was dried over a fire and weighed : it amounted to nearly twenty ounces Troy. This is esteemed a very rich place, and such circumstances are of rare occurrence. The whole neighbourhood is sterile, presenting the same characteristics as those before described. By proper cultivation it might be rendered very productive ; but, as the troops of negroes and their officers are continually changing, no regular establishments are formed.

This place probably derived its name from a most disagreeable insect, which infests the low brushwood in the neighbourhood. It is like a sheep-tick ; and, on getting access to any part of the body, it fastens imperceptibly, buries its head under the skin, and draws blood until its body is swelled to the size of a bean. If forcibly removed, it leaves a very deep disagreeable hole, which is frequently difficult to heal. The best mode of getting rid of the animal is to kill it with either laudanum or oil, and suffer it to remain until it dies, when it will drop off.

In the afternoon we returned to Tejuco by another route more mountainous than that by which we had come. Crossing a deep ravine, formerly very rich in diamonds, we rode up a mountain full a mile on the ascent, and passed several rivulets, which I was informed had produced many fine stones. These, and in fact all the best situations in the district, had been in the possession of the smugglers, and were explored by those enterprising men. In the course of our journey, I observed that whenever a traveller or a negro was seen by any of our party at a distance from the road, a soldier was instantly dispatched to bring him to the officers, before whom he underwent an examination.

In the evening we arrived at Tejuco, where I was desirous of remaining a week to recruit my strength. Mr. De Camara ordered my baggage to his house, whither I removed in compliance with his pressing invitation : he was kind enough to give me his library as my private room ; it was extensive and very select, consisting chiefly

of English authors on science. Adjoining to it is a fine garden of nearly three acres in extent, planted chiefly with grass. It was formerly a washing, and consequently presented a surface of only refuse stones; but the present proprietor levelled it, brought a little soil from various parts, and planted a peculiar variety of grass, which he keeps in cutting for his mules. This was the commencement of the fruit season; the peaches, with which the trees were loaded, were nearly ripe. The asparagus, and vegetables of every description, were very fine. The climate appeared to be mild and genial; the thermometer was generally at 62° at sun-rise, and at mid-day, in a room rather exposed to the sun, rose to 74° .

Tejuco being situated in a sterile district, which produces nothing for the maintenance of its inhabitants, in number about six thousand, depends, for a supply of provisions, on farms situated several leagues distant. The bread of the country was at this time extremely dear; Indian corn, from which it is made, being from 5s. 6d. to 6s. the bushel; beans and other pulse in proportion. Beef was very indifferent, this being the dry season; pork and poultry were rather plentiful. At no place do I recollect to have seen a greater proportion of indigent people, particularly of females. Full a hundred and fifty of these unhappy persons came weekly to receive portions of flour which the governor was pleased to allow them. They are totally without occupation, here being neither agriculture nor manufactures to afford them any; yet both these main supports of the population might be introduced, if a proper spirit of industry prevailed among the inhabitants. The land would, with little trouble, yield excellent crops, were any kind of inclosures made, which, it must be allowed, is an undertaking attended with some difficulties, yet not of such magnitude as to render it hopeless. With respect to manufactures, a most valuable material is at hand, as cotton from Minas Novas, distant only from sixty to one hundred miles, passes through this place to the capital.

Yet, notwithstanding the idleness of the inhabitants, Tejuco may be called flourishing, on account of the circulation of property created by the diamond works. The annual sum paid by Government for the hire of negroes, salaries of officers, and various necessaries, such as nitre and iron, does not amount to less than 35,000*l.*, and this, added to the demands of the inhabitants of the town and its vicinity, occasions a considerable trade. The shops are stocked with English cottons, baizes, and cloths, and other manufactured goods; also hams, cheese, butter, porter, and other articles of consumption. Mules from Bahia and Rio de Janeiro came loaded with them. Great complaints were made among the shopkeepers of the bad quality of the cotton goods, and of their losing their colours in washing. Some of the principal inhabitants exclaimed against the introduction of foreign luxuries, and rather wished that their trade with England should furnish them the means of working their iron mines, and enable them to defend themselves.

Tejuco, owing to its situation by the side of a hill, is very irregularly built; its streets are uneven, but the houses in general are well constructed and in good condition, compared with those of other towns in the interior. Its name, which, in the Portuguese language, signifies a muddy place, is derived from places of that description in its neighbourhood, which are rendered passable by being covered with large pieces of wood.

Through the kind care and attention of Mr. De Camara and his excellent family, my health was in part re-established, and I was enabled to ride out daily, occupying myself in seeing all I could, and gaining the best information, in which I was assisted by my worthy host and all his friends. Our evenings were passed in a most agreeable manner, among the parties which regularly assembled at the intendant's house, consisting of some of the principal inhabitants of the town. In these parties the gentlemen engage at whist, and the ladies take tea and play round games, or enter into conversation on the passing occurrences of the day. In no part of Brazil did I meet

with society so select and agreeable ; this may certainly be called the court of the mining district. In their manners there was no ceremonious reserve or courtly refinement, but their whole demeanour was genteel and well-bred, enlivened by an ease and good humour which the affability of the chief and his amiable lady and daughters ever tended to promote. The company all dressed after the English mode, and in dresses of English manufacture : the gentlemen were almost all distinguished with stars, yet they formed a *constellation* far inferior in brilliancy to that of the ladies.

I was invited to pay a visit to the treasury, which can only be viewed when a meeting of officers is called, as the treasure is kept in chests, under three distinct locks, the keys of which are entrusted to three several officers, who are all required to be present at the opening. They here shewed me the diamonds taken from the *tropero* at Concepção, which were in general much better than those from the mines worked by Government. One about eleven carats was a very fine stone, perfectly crystallized, in the form of an octaedron. The unfortunate man from whom they were taken, I was informed, was very ill in prison. I was then shewn about eight hundred carats, found in the regular course of washing ; they were in general very small, not one exceeding five carats. I observed one perfectly round, and several coloured. Those with a dark green crust upon them were, they informed me, when cut, of the purest water.

Here the diamonds found in the district are deposited monthly, as they are received from the different works. They are carefully weighed, and some selected and kept separate. The average quantity obtained may be estimated at from 20,000 to 25,000 carats annually, which are sent under a military escort to Rio, and there lodged in the treasury.

The diamonds are tied up in black silk bags, and deposited in elegant inner cabinets, the whole of which are locked up in strong chests bound with iron.

They then shewed me the gold, which was in large bars, weighing from five to ten pounds each, the whole of which I estimated at full 150lbs. weight. It was found in the district of Cerro do Frio, and was reserved to pay part of the expences attending the establishment.

An excursion was some days afterwards proposed to another diamond work, called Rio Pardo, distant about twenty miles in a north-west direction. After proceeding a third of the way, over a country covered with a poor wiry sort of grass, we passed several fine falls of water, and crossed a ridge of mountains. The land as we advanced appeared much better, though still very naked, having only a few poor crooked small trees, that rather increased than took from its desolate appearance.

We passed through Chapada, a little dirty village, once famous for its washings, as were all the streams and ravines in the vicinity, and proceeded over some good clay-land, and a considerable tract of peat-moss, well watered by streams which burst in all directions from the hills. The country was open, and had a most romantic appearance, caused by a quantity of low rocks of soft pudding-stone, laminated, which lay on the surface in the most irregular forms. These lands were well calculated for pasturage, particularly in the season of abundance, but I was told that the cattle put to graze upon them were frequently stolen by the negroes*, and that there were many noxious plants in the herbage which proved fatal to the beasts that ate them.

We arrived at the houses of the establishment about eleven in the forenoon, and walked four miles farther to the diamond works, on which a full troop of negroes were then employed. Rio Pardo is a dirty paltry-looking rivulet, which runs into the Rio Velho : in some

* Probably fugitive negroes, who subsist in this remote district by plunder and smuggling.

parts it is confined by shelving rocks of quartz, through which it runs rapidly ; in others it takes a serpentine course, and forms eddies, which are called caldrones, on account of their resemblance to the cavity of a boiler. The bed of the river, though confined, has a stratum of cascalhão of variable thickness, which, after the current has been diverted, is dug up, and washed in the same way as at Jigitonhonha. The caldrones, or holes, formerly eddies, but now partly filled with cascalhão, so as to be no more than three or four feet deep, are frequently found to contain many diamonds ; one of them, which was cleared by four men in as many days, produced one hundred and eighty carats.

Rio Pardo, though paltry and insignificant in its appearance, has produced as large a quantity of the most precious gems as any river in the district. The rough blueish-green-coloured diamonds, formerly so much esteemed by the Hollanders, continue to be found here, and the stones of this rivulet are to this day reputed the most valuable in Brazil. The accompanying substances are somewhat different from those of the washings at Mandanga ; here is no bean-like iron ore, but a considerable quantity of flinty slate-like Lydian stone, in various shapes and sizes, and very small black oxide of iron ; the earthy matter is also much finer than at the above place. I was informed that there remained as much unworked ground as would occupy a hundred negroes full twenty years.

Rio Pardo runs about a league to the westward of Capelho Velho, which is a chapel on a mountain, washed at its base by a stream called Corgo de Capelho Velho, which some years ago was worked, and produced diamonds of great size and superior brilliancy. The rivulets to the eastward of this ridge of mountains run into the Jigitonhonha ; those to the westward have their course into the Rio Velhò, which flows into the Rio de San Francisco. The height of the mountains I had no means of ascertaining, but they are considered as undoubtedly the highest in Brazil. The air in this elevated region is pure and rather keen ; the thermometer in the morn-

ings and evenings stood at 62, and at mid-day at 70. In all the parts which I visited the land appeared favourable for the growth of almost every species of produce, and, if properly inclosed and cultivated, might in no long time become the granary of the district.

On our return to Tejuco I was shewn several dwarfish trees, of the height and size of a common crab-tree, with extremely crooked branches; and was informed that they were a species of the *quercus suber*. I cut from them some pieces of bark about an inch in thickness, which were elastic, and actually proved to be cork. It seemed to me a question of considerable interest, whether these trees, if regularly planted and attended to, might not produce cork of as good a quality as that which we obtain from the Mediterranean.

After resting a few days, I accompanied the intendant to a small diamond work called Corrolina, and returned the same day. This work some years ago produced many good stones, but at present it employs very few people. The mode of washing is exactly the same with that practised at Mandanga.

At Tejuco some tolerably good barley was shewn to me; it was not so heavy as that of our best from Norfolk, and was but little known. The intendant uses it as provender for his mules whenever he can obtain it. On examining the sample, I could not but reflect that, if land so ill-managed produced such barley, how much superior would be the quality of the grain under good management.

At a subsequent period of my visit, the intendant, with whom malt-liquor is a favourite beverage, expressed a great desire to see some of the barley converted into malt, in order to brew beer, and, after repeated solicitations, I undertook to make the experiment. A quantity was procured, which I endeavoured to prepare in the best manner that circumstances would allow. Having steeped it the requisite time, I put it on a cold floor, and managed it as is customary in our malt-houses; when it had germinated sufficiently, I dried it over a slow fire; afterwards, having cleansed it from the combs

by rubbing, I crushed it, and finally mashed it. The infusion produced a tolerable wort, which, however, I did not deem sufficiently good, as it wanted saccharine matter: this deficiency I supplied by the admixture of a small quantity of sugar. It was then boiled until it was judged of a proper consistency, and a very pleasant bitter was added instead of hops. The fermentation I endeavoured to promote with leaven, which had been prepared a few days before, and, when that process had terminated, the liquor was put into small casks, which we stopped close. Though it might not prove good, from the hasty manner in which the process was conducted, yet the mode of preparing it was exemplified, which was the main purpose of the experiment. It appeared to me by no means impossible either to make malt or to brew beer, if proper places were made under-ground, so as to ensure a moderate degree of cold for the operation of mashing, and for the subsequent processes. Sugar is here so abundant, that any quantity of saccharine matter might be added to improve the poorness of the malt; and it is highly probable that a very pleasant beverage might be made, which would relieve the inhabitants of this remote district from the necessity of having recourse to the metropolis for bad wines, and from the ill effects which proceed from drinking bad spirits distilled in the vicinity.

Many parts of this fine country abound in oranges, pines, peaches, guavas, and a great variety of indigenous fruits, both sweet and acid, particularly the Jaboticubi, which is very rich in mucilaginous matter, yet no attempt has hitherto been made to obtain wine from any of them. Ginger and pepper grow here spontaneously, and many spices might probably be cultivated with success.

Grass for cattle was as dear at Tejuco as at Rio de Janeiro, and the small quantity which cost eight-pence would scarcely suffice a mule a day. The intendant and the captain of the cavalry had each of them about two acres under cultivation, of a species called *Engordo dos Cavalhos* (fattener of horses), which grew from five to seven feet high, with a thick esculent stem, and long lancet-shaped leaves.

It has a large fibrous root, and is well-calculated for stony ground where there is little earth; it even grew among rounded stones that had been washed three years before*.

The intendant, who had a taste for rural economy, and more particularly his lady, were very anxious to make their own butter and cheese, and expressed a great desire to be instructed in the process as practised in England, though milk was very scarce; and it was not without much difficulty that, after sending a few miles, about three gallons were collected. In the mean time such household utensils as were most fit for the purpose having been made ready, and others procured, very excellent butter was produced, and afterwards a few cheeses were made, which there was every reason to suppose would prove good. The lady interested herself greatly in the experiment, not only performing part of the operations, with the assistance of her daughter, but inviting several of her friends in the town to see with what little trouble the processes were performed, and distributing the products among them †: — a rare example of industry! I am decidedly of opinion that, were the females of Brazil better educated, especially in whatever relates to domestic economy, and were they accustomed to see the concerns of a household conducted with regularity and order, they would be very different subjects of society; for I have ever observed in them that inquisitive disposition and desire of information, which

* It was then in seed, of which I collected a small quantity; since my return, I have sent part of it to the Agricultural Society, and the remainder I have distributed among gentlemen who will endeavour to promote its growth in this country. It is rather a hardy grass, as it grew in situations which were all so cold, that the bananas and coffees were frequently blighted.

† The ladies particularly wished to have the cheese of a fine colour, like that sent thither from England; and I was at no loss for an ingredient for tinging the milk, as the tree, which produces the seed from which annatto is made, grew spontaneously in the neighbourhood.

may be called the first step to improvement. But what can be expected from ill-educated females, reared from their infancy among negras, in miserable houses, scarcely affording a shelter from the rain or a shade from the sun, and destitute of every ray of comfort !

CHAP. XIV.

Some Account of the Districts of Minas Novas and Paracatù. — Of the large Diamond found in the River Abaitè.

IT was my intention to have continued my journey to Minas Novas, and from thence westward to Paracatù, and to have returned by Abaitè, a place that has produced many large diamonds, though generally of inferior quality. This design I was prevented from accomplishing by illness, being attacked with a violent sciatic complaint, accompanied with great debility in the right side, which obliged me to return as soon as possible. While I remained at Tejuco, for the purpose of regaining strength sufficient to encounter the fatigues of a journey back to the capital, I employed myself in collecting information respecting these districts from intelligent persons who resided there, as well as from officers on the establishment. The following brief description is the result of the communications with which they favoured me.

The principal village in Minas Novas, called Tocaya, is thirty-five leagues distant from Tejuco, in a north-easterly direction. The road thither is parallel with the river Jigitonhonha, which runs from two to five leagues westward of it*. Numerous rivulets flow into it in this direction, in some of which are found white topazes, more commonly known here by the name of *minas novas*. They are pretty pellucid pebbles, generally rounded,

* On the road there are numerous farm-houses, which afford sufficient accommodation for a traveller to pass a night. They in general belong to persons resident in Tejuco, where their produce is sold.

though sometimes they occur perfectly crystallized, in the same form as the yellow topaz. Blue topazes and *agua-marinas* are also found here; some of the former are of a singular variety, being in one part blue, and in the other, clear and pellucid. This neighbourhood is also noted for producing the beautiful *chryso-beryl*, which is much esteemed by the higher orders of society in Brazil, and in great request among the jewellers of Rio de Janeiro. These gems rarely occur crystallized; they sell at considerable prices in their rough state, and are much more valued in America than in England, where, indeed, they are little known, or they would be more highly appreciated, being, when polished, of great brilliancy and very beautiful.

To the westward of the river *Jigitonhonha*, and opposite the village of *Bom Successo*, is the *Cerro of Sant Antonio*, a place much famed for diamonds, which are said to be of an indifferent quality. There are, also, other parts, well known to many of the inhabitants of the district as being rich in these treasures.

The country is very fertile, and produces a great variety of the finest woods for cabinet-works; also numerous fruits, and most exquisite vanilla, which grows spontaneously. The land, being less elevated* than *Cerro do Frio*, is said to be much warmer, and is highly favourable to the growth of sugar and coffee. The plantations are chiefly of cotton, which is reputed to be equal in colour and quality to that of *Pernambuco*. It is transported to Rio de Janeiro on mules, and many hundreds of those useful animals are continually employed in this commerce. A troop of loaded mules are full three

* In some of the low swampy tracts large serpents are not uncommon. At *Tejuco I* was shewn the skin of a young one, said to be of the *Boa Constrictor* genus. It was twenty-four feet in length, and about twenty inches in circumference. To relate the stories told of these reptiles, — of their catching bullocks, and afterwards swallowing them, — would ill-become a work of veracity; the horned cattle of *Minas Novas* being as large, though not so full of flesh, as ours in England.

months, and sometimes four, in going, and the same time in returning. These animals in this district are double the price that they are in St. Paul's. The journeys are attended with considerable expence and difficulty; Indian corn must be daily bought for their use; and, notwithstanding the great attention paid to them on the road, many die, and others are frequently lamed and disabled. Their burdens are divided into two equal parts, and suspended on a pack-saddle of peculiar make by straps of raw hide. The average burden is nine arrobas, nearly equal to three hundred pounds weight, the carriage-expence of which, from Rio de Janeiro to Minas Novas, is six or seven pounds sterling; to Tejuco five pounds; to Villa Rica about three.

The trade to Minas Novas from Rio de Janeiro consists principally in negroes, iron, salt, woollens, hats, printed cottons, hard-ware, arins, and some fancy articles, a little wine and oil, salt-fish, and butter. Few luxuries enter these remote parts, the inhabitants seeking for little beyond mere necessaries.

Minas Novas is under the jurisdiction of the Ouvidor of Villa do Principe, who goes thither once a year to settle disputes, administer justice, and discharge other duties belonging to his office.

At Tocaya the Jigitonhonha flows into a larger river, called Rio Grande, which, taking an easterly direction, enters the sea in lat. $16^{\circ} 20'$ south, near Porto Seguro. A gentleman with whom I was acquainted undertook to navigate this fine river from Tocaya to the sea, and, as the current was rapid, he performed the task in six days. On his return, which occupied fifteen days, he observed several tributary rivers, the communications of which are unknown, as they rise in the country inhabited by the Indians. The river being free from falls, may in time be frequented by vessels from sea, for I did not learn that its entrance was shallow or unfit for navigation. Probably the land about it is low and marshy, which may be the reason that it is so little known.

It cannot be too much recommended to the Government of Brazil immediately to order a survey of this river, which might be performed in one of their launches in two months at little or no expence, and, were it found necessary, a chain of connection might be established from its mouth to Tocaya. The benefits resulting to the inhabitants from opening the navigation may be easily conceived. The produce of the country, its cotton, coffee, and sugar, its rich cabinet-woods, and many other valuable articles, would be brought into active commerce; extensive plantations would be established, and the whole territory would be improved. It is true that the commerce of the district would flow through another channel, and the tolls paid on passing the Paraibuna, to and from the capital, would be a little diminished: but surely the policy of Government is not so confined as to allow that consideration to have any weight against a measure of such national importance, when it is obvious that one of the greatest disadvantages under which the empire of Brazil labours, is the want of commerce on all its rivers, except the Rio Grande de St. Pedro.

The population of Minas Novas is thin, compared with its extent, but is daily increasing. It does not appear that mining is the object which attracts settlers, though there is a considerable quantity of stones exported, which are found only here, as has been before observed.

Where the rivers are deep it is very difficult to raise the cascalhão from their beds, in order to wash it for gold, &c.; for this purpose various trivial and ineffectual methods are practised: it would be highly conducive to the interest of the proprietor, as well as of the state, to have rafts or boats constructed, and to adopt the machinery used by the ballast-heavers on the river Thames, by means of which the cascalhão might be raised, even from a depth of twenty feet, however rapid were the current. This machinery is highly to be recommended, not only in this district but throughout the mining country; were a model of it made by order of Government, and the

requisite iron-work prepared in Rio de Janeiro, (if necessary,) and admitted into the mining country, free of duty, there would probably be such an increase of gold obtained by it, that the proportionate augmentation of the royal fifths would amply repay the expence of introducing the improvement.

Paracatu is the principal village or town of a district of the same name, which lies about ninety leagues north-west of Tejuco, bordering on the Capitania of Goyazes, from which it is separated by a chain of high mountains that take a northerly direction. The numerous rivers which rise on the eastern side of the mountains, and flow into the great river St. Francisco, are rich in gold. The population of the village is estimated at above a thousand souls, and will shortly be more numerous, as the reputed richness of some late discoveries has tempted many families to migrate thither. It has all the advantages of a high and healthy situation, in the midst of a most fertile country, and has considerable intercourse with Sabara and Villa Rica, where the gold procured in its vicinity is permuted. It is governed by a Captain Mor, who is subordinate to the governor of the latter place, to whom all disputes of consequence are referred. To the southward is the rich *distacamento* of Rio Plata, a river that yields fine diamonds, and has been much frequented by many adventurers, who, when discovered and seized, are called smugglers. A strong guard of soldiers is stationed here to prevent the precious stones from being sought for clandestinely.

A few leagues to the north of the Rio Plata is the rivulet named Abaitè, celebrated for having produced the largest diamond in the Prince's possession, which was found about twelve years ago. Though this circumstance has been already briefly stated, it may be allowed me in this place to relate the particulars as they were detailed to me during my stay at Tejuco. Three men, having been found guilty of high crimes, were banished into the interior, and ordered not to approach any of the capital towns, or to remain in civilized society, on pain of perpetual imprisonment. Driven by this

hard sentence into the most unfrequented part of the country, they endeavoured to explore new mines or new productions, in the hope that, sooner or later, they might have the good fortune to make some important discovery, which would obtain a reversal of their sentence, and enable them to regain their station in society. They wandered about in this neighbourhood, making frequent searches in its various rivers for more than six years, during which time they were exposed to a double risk, being continually liable to become the prey of the Anthropophagi, and in no less danger of being seized by the soldiers of Government. At length they by hazard made some trials in the river Abaitè, at a time when its waters were so low, in consequence of a long season of drought, that a part of its bed was left exposed. Here, while searching and washing for gold, they had the good fortune to find a diamond nearly an ounce in weight. Elated by this providential discovery, which at first they could scarcely believe to be real, yet, hesitating between a dread of the rigorous laws relating to diamonds, and a hope of regaining their liberty, they consulted a clergyman, who advised them to trust to the mercy of the state, and accompanied them to Villa Rica, where he procured them access to the governor. They threw themselves at his feet, and delivered to him the invaluable gem on which their hopes rested, relating all the circumstances connected with it. The governor, astonished at its magnitude, could not trust the evidence of his senses, but called the officers of the establishment to decide whether it was a diamond, who set the matter beyond all doubt. Being thus, by the most strange and unforeseen accident, put in possession of the largest diamond ever found in America, he thought proper to suspend the sentence of the men as a reward for their having delivered it to him. The gem was sent to Rio de Janeiro, from whence a frigate was dispatched with it to Lisbon, whither the clergyman was also sent to make the proper representations respecting it. The sovereign confirmed the pardon of the delinquents, and bestowed some preferment on the holy father.

The governor ordered a guard on the river, which was soon afterwards worked under the direction of the intendant of Cerro do Frio, who sent thither an administrator and two hundred negroes. It has since been worked at different periods with various success; sometimes large stones have been found, but of an indifferent quality. The work is now abandoned by Government, and gives occupation to numbers of adventurers. Its neighbourhood has many interesting places, hitherto but little explored.

A few leagues from this river is a very strong vein of lead ore (lead glance) in a calcareous matrix. I have seen pieces of it of the weight of twenty pounds, and it is said to be so abundant that any quantity may be obtained. Some of the specimens presented to me were covered with carbonate of lead. It has the appearance of a potter's ore, and is said to be poor in silver. No one has undertaken to work it, as the difficulty and expence of conveying the metal to Rio de Janeiro would exceed the price at which it would sell in that market*. When the neighbourhood becomes more populous, and the value of this useful metal is better known, the mine will probably be a source of riches, for lead ore is certainly scarce in Brazil, nor did I hear of any other place which produces it.

The river St. Francisco is very considerable, and is said to contain great quantities of fish†, which is a sufficient proof that there are but few gold-washings in it. On the banks, and in the country to the eastward, great numbers of cattle are bred, which are sold in all the populous towns of the captaincy, and large herds are sent to Rio de Janeiro, a distance of above six hundred miles. A considerable commerce is carried on with them, and some families who raise large quantities are reported to have acquired great fortunes by it. The

* It may become useful at Villa Rica: but the quantity required there at present is so trivial as scarcely to merit attention.

† If salt were cheaper they might be cured, and would become an article of commerce, particularly during Lent.

want of salt is a very general complaint ; the cattle require it, nor will they breed well without it.

This district is too far distant from a sea-port to enjoy any extent of commerce in the general articles of its produce. Gold and precious stones are easily transported, but lead, and other commodities of greater bulk and inferior value, would scarcely pay the expence of carriage. Hence no cotton, coffee, or sugar is grown for exportation, and the quantity consumed in the district is very limited, owing to the small number of the inhabitants, and the miserable indigence in which they generally live, their common diet being Indian corn-flour, boiled beans, and a little pork. The trade to Rio de Janeiro is much similar to that of Minas Novas, and consists chiefly in iron, cotton, arms, hard-ware, and a few trivial luxuries. Persons of all ranks are eager to purchase negroes, also a few woollens. The only articles sent to Villa Rica are gold-dust and hides.

In this district, and in other parts of these immense territories, particularly to the eastward, are large tracts of land *volute*, or not occupied by any person under a grant from government. These lands to a considerable extent may be taken by making proper application, and afterwards held as freehold. Other excellent situations are in the possession of idle people, who are equally incapable and unwilling to reap advantage from them. These may be bought very cheap, and are certainly preferable to the unoccupied tracts, as they have generally some few conveniences attached to them, and may, therefore, more easily be brought into a proper state of cultivation. Here is every inducement for a spirited and experienced agriculturist to settle : a rich and fertile district, in which there remains much to be discovered in every department, where all the necessaries, and many of the luxuries, of life are produced almost spontaneously ; and where the exertions of industry would be rewarded in a tenfold degree by the bounteous hand of nature, and stimulated by the cer-

tain hope of arousing a degenerate race of men to follow the example. Nor could there be any objection on the score of differences in opinion; for I am persuaded that no one would here be molested for his religious tenets, while he prudently avoided giving offence, and paid the same regard to the conscience of his neighbour which he expected for his own.

CHAP. XV.

Observations on Tejuco and Cerro do Frio.

IN the foregoing pages I have endeavoured to present to the reader a narrative of whatever I observed worthy of note in the Diamond District, and have related the several particulars in the order in which they occurred to me, reserving the task of general description for that period of my residence there when I might be supposed best qualified to perform it. This mode of proceeding will expose me to the risk of a few repetitions, for which my apology must rest on the peculiar circumstances under which I visited Tejuco, — on the continual journeys in which I was occupied from the moment of my arrival to the time when I was attacked by illness, and which left me no leisure for combining my actual observations with general views of the country.

The district of Cerro do Frio consists of rugged mountains, that have a northerly and southerly direction, and are generally allowed to be the highest in Brazil. What is termed the Diamond ground, extends about sixteen leagues from north to south, and about eight from east to west. It was first explored by some enterprising miners from Villa do Principe, a few years after the establishment of that town. These men proceeding northerly found an open country, watered by many small rivulets, which they tried for gold by washing: some of them engaged their attention for a short time, but not proving sufficiently rich, they continued their route, passing the places now called San Gonzales and Melho Verde, until they arrived at a few streams that flow from the base of the mountain on which Tejuco is built. These rivulets were then washed for gold, and were

considered as belonging to the district of Villa do Principe. No idea was first entertained that the rivulets contained diamonds, although it is said that some were collected and presented to the then governor of Villa do Principe as curious bright stones, and were used by him as counters at cards. Soon afterwards a few of them found their way to Lisbon, and were given as pretty pebbles to the Dutch minister to send to Holland, which was then the principal mart in Europe for precious stones. The lapidaries, to whom they were presented for examination, pronounced these pebbles to be very fine diamonds. Information was accordingly sent to the Dutch consul at Lisbon, who did not fail to profit by the occasion; for he managed the affair with Government so well, that he contracted for the precious stones at the same time that he communicated the intelligence. Government afterwards endeavoured to monopolize the diamonds, and made a distinct district of Cerro do Frio, placing it under peculiar laws and regulations.

The number of diamonds sent over during the first twenty years after the discovery is said to be almost incredible, and to exceed one thousand ounces in weight. This supply could not fail to diminish the general value of diamonds, as none had ever before been known to come from any other part of the globe, except India, whither the Brazilian diamonds were afterwards sent, and found a better market there than in Europe.

By stratagems and intrigues Government was prevailed on to let these invaluable territories to a company, who were under stipulations to work with a limited number of negroes, or to pay a certain sum per day for every negro employed. This opened a door to every species of fraud; double the stipulated number of negroes were admitted; and this imposition was connived at by the agents of Government, who received pay in one hand and bribes in the other. Presents were made to men possessing influence at court, by the contractors, who soon became rich, and they continued (subject to a few regulations) in possession of the diamond mines until

about the year 1772, when, Government determining to take them into their own hands, these contracts were ended.

This was the time for reforming abuses, and for placing this rich district under the best regulations, but it was neglected; prejudice prevailed over prudence; and the management was entrusted to men who did not understand the real interests of the concern, or, what is more probable, who were so shackled in their authority, that they could not pursue them. From this time affairs became worse, and the establishment was in debt to foreigners, who had advanced a considerable sum of money on the security of having all the diamonds which the mines produced. This debt still remains unpaid, and there are other incumbrances, which can be removed only by a total change of system. In its present state the establishment appears to produce much greater wealth than it actually does. During a period of five years, from 1801 to 1806 inclusive, the expences were 204,000l.; and the diamonds sent to the treasury at Rio de Janeiro weighed 115,675 carats. The value of gold found in the same period amounted to 17,300l. sterling, from which it appears that the diamonds actually cost Government thirty-three shillings and nine-pence per carat. These years were esteemed singularly productive; the mines do not in general yield to Government more than 20,000 carats annually*.

The town is under the absolute government of the Intendant. The principal officers of the civil and military establishments are, an *ouvidor* or *fiscal*, a captain of cavalry, and a captain mor. In the Diamond establishment there is a great number of officers, of whom the following are the principal: 1st, the Intendant, who is a judge, and intendant-general of the capitania of Minas Geraes (this office is one of the best in the gift of the crown); 2d, the Treasurer, whose situation is almost a sinecure: he receives 8,000 cru-

* Exclusive of this amount, there is a vast quantity smuggled.

sades per annum ; and 3d, the Administrator-general, who has a salary of 6,000. The book-keeper has 4,000, and three clerks, or key-keepers, have from 800 to 1,000 each. These officers are employed in whatever relates to the treasury, or to the general concerns of the establishment ; they all reside in Tejuco, and are the most respectable of the inhabitants. The management of the different works is entrusted to eight or ten under-administrators, each having in his care two hundred negroes, called a troop, to which, besides a clergyman and a surgeon, are attached several overseers and subordinate officers, who have salaries of from 400 to 200 crusades. The privilege of employing a certain number of negroes in the works is common to all the officers, to an extent corresponding with their rank : the superior officers let to hire as many as they please, say forty, and sometimes upwards of fifty ; the inferior officers are permitted to let out two or three, in preference to other individuals ; a decidedly bad practice, as will be shewn hereafter.

The Intendant holds a place of great trust : he is the superior magistrate, and his duty is to administer justice, and to see that the laws peculiar to the district are duly executed. He is of course president of the assembly, or juncta, and calls meetings whenever he thinks proper ; he disposes of the military force of the district, orders roads to be made or stopped, and stations guards on them to examine travellers, and to detain suspicious persons. He has also the privilege of giving or refusing permission for persons to enter the district, or settle in it ; and every one, however high in rank or property, who passes thither is supposed to have the Intendant's express concurrence, which, as a matter of form, is sometimes dispensed with. He appoints officers, signs all papers, receives all reports that are made, and acts accordingly. To him solely the treasure is entrusted for the payment of the salaries of the officers, the negroes' wages, tradesmen's bills, and every incidental expence attending the establishment. He issues paper-money, and withdraws it from circulation whenever he thinks proper ; for all which he is responsible to

Government alone, and may be said to be almost absolute in his office.

In addition to these important functions, the present Intendant has assumed the whole direction and regulation of the mining concern, which none of his predecessors ever practically interfered with, it being the peculiar province of the administrator-general. For this undertaking he is equally qualified by the superiority of his talents, and by the extent of his acquirements: he studied mineralogy many years under the celebrated Werner, by whom he was considered as one of his most enlightened disciples; afterwards he travelled through Hungary, and all the most interesting German states, and, lastly, made the tour of England and Scotland, where he resided two years.

The Administrator-general, to whom belong the direction and management of the works, ought to be equally experienced in mining and mechanics, particularly in hydraulics: he should be a man of general information, combined with great practical knowledge relative to the locality of the district, so as to be able to ascertain the real value of every situation, and to direct the operations accordingly. He should have a mind fertile in resources, and prepared to meet every disappointment or casualty that can possibly occur, that the time of the negroes may not be employed in vain; he should also facilitate their labours by the introduction of machinery, and should be particularly attentive to their good treatment, since on them his success, and consequently his reputation, must in a great measure depend.

On this latter point humanity and policy ought alike to direct the attention of the superiors of the establishment. It is natural to suppose that negroes, when treated with harshness, ill fed and ill clothed, will be indifferent to the interests of their employers, and, perhaps, determined not to find diamonds, whereas, when subjected to milder and kinder usage, which might be done without relaxing in vigilance, they would become anxious to please, and would search more dili-

gently in order to obtain notice and reward. It must be obvious that negroes rarely conceal diamonds for themselves ; and yet custom has rendered the feelings of their real owners in Tejuco so irritable, on being suspected to encourage the practice, that if the word *grimpero* (smuggler) is mentioned in conversation, they shudder with horror and distort their features, calling on the Virgin to witness their abhorrence of a crime to which Government has attached the greatest disgraces and punishments.

Pure, honest souls ! Being a stranger in the country, I conceived that these gentlemen really felt the sentiments which their words and gestures expressed ; and, as persons of all ranks seemed to fear conversing on the subject, I thought at first that I should not see a single diamond in all Tejuco, except those in the treasury ; but a little acquaintance with the town soon convinced me that I was a novice ; for, on visiting a few friends to whom I had introductions, I found that diamonds were bartered for every thing, and were actually much more current than specie. Even pious indulgences were bought with them ; and surely no one could have suspected that the seller of His Holiness's bulls would condescend to taste the forbidden fruits of Tejuco*.

As I had the honour to reside at the house of the Intendant, I was considered by the people of the town as a person connected with Government, and therefore as one who ought not to be informed of the secret traffic among them ; hence, when in company with the officers of the establishment, whenever the word *grimpero* was mentioned, I found it necessary to manifest the same feelings of disgust which they did ; and, on expressing my surprise that any one could so far degrade himself as to be guilty of the crime of smuggling dia-

* The privilege of selling dispensations in this capitania is bought at Rio de Janeiro, or of the worthy Bishop of Mariana, who derives great advantage from it. The sale is regarded as a most excellent *take*, and yields a very considerable income to the present holder, who possesses the talent of pleasing those most who pay the highest price.

monds, it was tacitly agreed that no white man could stoop to such dishonour. The point was soon settled ; for I found it best not to oppose general opinions, nor to enter too minutely on delicate subjects ; and it was sometimes expedient for me to seem regardless of what I was most stedfastly looking at.

In Tejuco there are about nine or ten principal shopkeepers, to whom the establishment itself, and the officers belonging to it, are frequently indebted ; indeed, these men receive the greater part of the money due to the various persons employed in the works, in exchange chiefly for English commodities of one description or other. The establishment is paid once a year, and for this purpose a sum not less than 300,000 crusades is sent from Villa Rica, to which may be added 60,000 or 100,000 more, found in the gold mines of the district. The greater part of this money flowing into the hands of the shopkeepers, as above-stated, is immediately employed in a way injurious to the interests of Government ; nor can worse policy be imagined than that of allowing so large an expenditure in a place which offers such temptations.

Some years ago many gold-mines were washed in this district, but as information was given that diamonds were found in them, they were ordered to be abandoned. At present more equitable measures are adopted, and the proprietors are commencing to work some of them again, under an agreement to give up what diamonds they find*.

* One Sunday morning during my stay, an owner of a washing came to the house of the Intendant, and brought him two miserable diamonds of bad colour, which did not weigh together above five grains ; and these, he said, were all which his ten negroes had found in six weeks. In the course of conversation, the Intendant observed that all the smugglers were either imprisoned or dispersed, when the man immediately assumed an appearance of great disgust at the mention of persons of so vile a description, and was liberal in his epithets of abuse on them.—If I durst have enquired how it happened that his negroes in six weeks could find only two *bad-coloured* diamonds, what emotions would this immaculate miner have manifested !

There is a general order to work all the gold-mines which were formerly confiscated, and this measure will, it is hoped, increase the quantity of gold, and have a good effect in every respect.

If Government are obliged to hire negroes wherever they can obtain them, (which appears to be the case,) it would be at least expedient to have a store to supply them, in order that the money paid in wages to them might return into the funds of the establishment.

The hiring of negroes to the diamond works is the favourite occupation of all ranks in Tejuco ; rich and poor endeavour to engage in it to as great an extent as their property will allow. The pay of the slaves is trifling compared with the risk, their labour being heavy, their maintenance poor, and their treatment harsh ; there must, therefore, be some temptation not openly seen, yet as well known as light from darkness. Numbers of persons are thus induced to reside in Tejuco under various pretexts, but with no other real view than to get their negroes into the service, and to live idly on their wages, and on what they conceal or pick up. Thus all fatten upon the pasture, except those in the extreme of indigence, and others who, from neglect of economy, are always poor. There are a numerous class, from the age of seven years to upwards of twenty, who are without any visible means of earning their subsistence, and would remain idle even if manufactories were established ; for though they are brought up from their infancy with negro-children, yet in the working department they would abandon their former play-fellows. The people in general are rendered more averse from habits of regular industry by the continual hopes which they indulge of becoming opulent by some fortunate discovery of mines ; these fallacious ideas, which they instil into the minds of their children, strongly prejudice them against labour, though they all exist miserably, and not unfrequently depend upon donations. Their education is extremely limited : they are in general total strangers to the sciences, and are very scantily informed on any useful subject.

As the object of my journey into this district was to examine into the real state of affairs, and to give a true report of them on my return, for which purpose I was furnished with many privileges never allowed to any person before, and was thus enabled to see all that I desired, humanity requires that I should make some observations on the fate of those unfortunate persons who have been tempted to smuggle diamonds, and have been caught in the act. I even mentioned the subject to the minister on my return to Rio de Janeiro; but as his occupations were great, and the state of my health required me to leave the country immediately, nothing more was said of it.

The great demand for these precious articles, and the facility of secreting them, have caused them to be searched for and carried away in violation of the existing laws of the country. Of the numbers who have engaged in this illicit traffic, from an eager desire to become rich at once, many have eluded the vigilance of the guards, and have finished their career with credit and opulence; others less fortunate have been detected, and have incurred the punishment annexed to the offence, namely, the surrender of their illegally acquired treasure, the confiscation of their whole property, and exile to Africa, or confinement, perhaps for life, in a loathsome prison. Mild as are the criminal laws of Brazil, the latter part of this sentence is an exception at which human nature shudders. Surely, when a poor wretch who has been tempted to this offence has atoned for it by the loss of all he possessed, he has suffered sufficiently without being subjected to the forfeiture of personal liberty, and to all the woes incident to hopeless captivity. Far be it from me to countenance any infringement on the laws which have been established for the protection of property, either public or private; to respect the institutions of whatever nation I may live in, I hope I shall always be among the first, and to encourage others to disregard them, the very last; for illicit trade of every description is a deceitful and dangerous pursuit, the sweets of which are ever attended with a counteracting portion

of evils. The object of my reasoning is to shew that these degraded persons have been of service to the state, and may still be rendered useful to it. May it be permitted me to enquire who were the discoverers of perhaps all the diamond mines which have enriched the caskets of the royal family of Portugal beyond comparison with those of any other state, and which have not only augmented the revenues of the government, but have proved the source from which many respectable and enterprising individuals have derived their opulence? Adventurers, who, at great risk and with indefatigable toil, have penetrated unknown forests, and explored deep ravines among the haunts of the savage Anthropophagi, in search of gold-mines, and in them have by chance found diamonds. When a place of this description has been once discovered by these men, it seldom remains long secret; the agents of Government take possession of it, and either work it immediately, or guard it until a future occasion. The discoverer of course flies from the place; and if he have picked up a few stones, or robbed the earth of some of its most brilliant rarities, he will seek the best and safest means of procuring value for them. If he be a man of sufficient property, he will hire a few mules, load them with cotton, bacon, and other commodities, and proceed to Rio de Janeiro in regular form. On his arrival there, he enters some good house in which he has confidence, and disposes of his concealed treasure. His mind is then relieved from apprehension, and he begins to make preparations for his return. His first care is to lay out his money to the best advantage: negroes are his chief object, and these pay a duty to the state on their leaving Angola, and another of ten milreis each on entering the mining country. If they be employed in mining, Government obtains a fifth of the gold found, and if in agriculture, a tenth of the produce is exacted. The next object of the adventurer is to lay in a stock of woollens, and other English manufactures, which pay a duty of fifteen per cent. on being landed, and are subject to another, according to their weight, on entering the territory of the mines. Thus it really appears that

most of the contraband property is divided between the state and the smuggler : but this is not all ; the diamonds are sent out of the country, and real effects of value are received in return, leaving a balance much in favour of Brazil.

This illicit trade has been carried on to a very considerable extent : there is strong presumptive authority for stating that, since the first discovery of the mines, diamonds to the amount of two millions sterling have thus found their way to Europe, exclusive of what the contractors accounted for. This has been owing to the ill management of the whole establishment, and to the total want of necessary regulations, which have prevailed so long, that it will not be easy to apply a remedy. Let us suppose for a moment the system to be changed ; the two thousand negroes employed in the establishment to be the property of the crown (whom two years' profit of the diamond mines would be adequate to purchase) ; these negroes to be supplied with every article for their support from a general store, and to be treated as mildly as possible : they would then form a society, and, knowing no other masters than their officers, would have only one common interest to serve. The contraband trade by this means, though perhaps not totally destroyed, would receive an irrecoverable blow, and would be reduced almost to nothing. Should such a change take place, the shopkeepers, and those persons who subsist by hiring negroes to the works, would find the source of their emoluments dried up, and, rather than remain at Tejuco, would migrate to situations more congenial to their interests : thus the district would be freed from that bane which has so long over-run it, and Government would reap the advantage of having the mines worked by their own negroes, whom it would be difficult for others to seduce.

Another evil which such a change of system would be calculated to remove, is the following :—Every article of sustenance required for the establishment is purchased of farmers who reside a few leagues from Tejuco, or who have farms at a greater distance ; and this ab-

surd practice is the cause of much unnecessary intercourse. There are thousands of acres of excellent land in the vicinity of the diamond works, having choice of situation, and fit for the growth of every species of produce. How well might a part of the force above-mentioned be occasionally spared for a few days only, to be employed in the first operations of husbandry, which would be, to inclose a sufficient quantity of ground in various parts for the maintenance of the establishment. A certain number of negroes would be allotted, in proportion to the land under cultivation, and on particular occasions, as in harvest, an auxiliary force would be always at hand. This would be farming with double advantage; the plough would work instead of the hoe; after-crops would be sown to be eaten off the ground, which would thus be enriched and kept in good condition. Numbers of acres would be planted with artificial grass, subject to irrigation where that was practicable, and thus, contrary to the general practice, the cattle would be provided with subsistence in the dry season. Indian corn, wheat, mandioca, feijones, potatoes, &c. would be cultivated, and, under proper management, would yield crops equal to the most sanguine expectation. Store-houses, with requisite conveniences, would soon be erected, in which the grain might be kept without spoiling. Thus would the first principles of husbandry be introduced into the district, and prove a source of more lasting benefit to the state than mines either of gold or diamonds, for when the latter were exhausted there would remain an active and industrious population. It seems, indeed, to have been the purpose of nature, in distributing these precious substances in these remote and almost unknown parts, to allure civilized men to settle upon them.

From the circumstances which have been already explained, it will appear that, under the present system, the Government pay for all the diamonds that are found here, and probably receive little more than one-half; therefore it is evident that those conveyed through other channels can be sold to the public at a lower price than that

at which the former are obtained. But the embarrassed state of the establishment is such, that the managers cannot lessen their expences, being obliged to take credit for every article, and to hire almost any negroes that are offered. These evils have taken too deep root to be eradicated, even by the abilities of the present Intendant: had such a man been placed here forty years ago, empowered to act without controul, and to govern the district as private property, on the principles above stated, he might have rendered it rich and independent.

As all the diamonds found in these works belong to the crown, the royal family have been accustomed to select from the quantity annually remitted whatever stones they considered worthy their notice, which were generally those exceeding seventeen carats. They were formerly sent to Holland to be cut, the Dutch being the contractors of the diamonds, from the first discovery of the mines; but since the emigration of the court to Rio de Janeiro, that trade has been transferred to England, where these precious stones annually arrive, and are sold by private contract.

The collection of diamonds now in the possession of the Prince Regent is unequalled in number, size, and quality, by that of any potentate in the world; and I am credibly informed that it exceeds in value three millions sterling.

This district has a direct communication with Bahia, and a few troops of mules are continually employed in going from one place to the other. The journey is much longer than to Rio de Janeiro, but the country is less mountainous; there are fewer ranchos or hovels on the road, and in two parts it is requisite to carry fresh water for two days' consumption. The commodities sent from Tejuco and Minas Novas are very trivial, consisting of topazes, amethysts, and other stones; in return for which are brought English fine manufactured goods, particularly hats, printed cottons, stockings, and saddles, which have been much cheaper in Bahia than in

England. Coarser articles are generally sent from Rio de Janeiro, the distance being, as before observed, much shorter.

Of navigable rivers we can say but little. The many small streams that rise in various parts join, and form the Jigitonhonda, which, as before observed, may be navigated to sea, without any impediment, in at most ten days time. How much would the country be benefited if a port were established at the entrance of this river, and vessels were allowed to load and unload ; canoes would find their way from thence into the interior in the short space of twenty days, loaded with every article necessary for the consumption of the district. How superior would this mode of conveyance be to that of making roads through impervious woods, and over almost impassable mountains. How many thousands of crusades annually expended on mules would be thus saved to the public, and what numbers of men would thus be trained for the service of the marine, instead of those now employed as muleteers. With the advantage of such a communication, Minas Novas and Cerro do Frio would soon more than double their population, and it might be anticipated that the banks of these fine rivers, now lying deserted and useless, would bloom with every variety of vegetation which this genial climate is capable of producing.

Under the present system Tejuco ought to maintain itself, and have the least possible intercourse with other places. Its commerce ought to be confined wholly to gold and precious stones ; but should Government determine to make diamonds a free trade, then a contrary policy would be requisite. On this subject I shall, in the sequel, have some observations to make.

The quadrupeds of Cerro do Frio are common to other parts of Brazil. Mules are the principal beasts of burthen, and are much dearer than in the districts more to the southward. Horses are not so numerous, but cheaper, being in very little request, and used only on journeys of pleasure. Horned cattle are bred at a considerable distance, and brought for the consumption of the place. Sheep are

almost unknown ; hogs and goats are more plentiful ; of dogs there are but few, and the race is very indifferent. Ounces are very seldom seen ; there are not many deer ; the danta, or tapir, is not uncommon.

Of birds there are a few varieties, but in no great numbers : partridges are rather common ; we shot several in our way to the different mines, which proved good eating. Domestic fowls are in tolerable plenty, but by no means cheap, being eighteen-pence to two shillings each.

Of serpents, I saw only one, and it was harmless : but I was informed that the rattle-snake and the jararaca, both equally venomous, are common in this district. Lizards are very numerous, and the *cayman*, or alligator, is found in most of the rivers.

Fish are extremely scarce in all the streams, owing to the quantity of matter with which their waters are impregnated from the numerous washings.

This district is in general free from that troublesome plague, the mosquito, as that insect is peculiar to low and swampy places, and does not bite with such disagreeable effect in elevated and airy situations. Bees are but little attended to, and are scarcely known ; were the management of them better understood and practised by the inhabitants, they might be much increased, and wax might even be exported.

In closing my observations on this district, I may be permitted to add some particulars relative to the capital. The families whom I had the honour to visit appeared to live in great sociability. They frequently form tea-parties. The dress of the ladies consists almost entirely of articles of English manufacture, cotton prints, straw hats, artificial flowers, jewelry, &c. Owing to the great distance of Tejuco from a sea-port, piano-fortes have not been introduced here, or they would probably be in great demand ; for the ladies in general have a taste for music, and touch the guitar with great spirit and elegance. Dancing is a favourite amusement, and all appear much pleased and

animated with the English country-dance. The ladies seldom go abroad, except to mass, and then they are usually carried in a chair hung with curtains and a canopy, and suspended from a pole, borne by two men. The sedentary habits of the females I have often thought injurious to their health; but, since English saddles have been introduced, they begin to take airings on horseback.

Warm baths are very generally used, being considered of great efficacy in removing recent colds, to which all persons here are liable, on account of the peculiar nature of the climate. They are invariably offered at night to travellers, as a means of relieving the pains occasioned by the fatigues of the day.

A continuance of ill health obliged me to take leave of my friends in Tejuco, and to return to Rio de Janeiro with all possible expedition. It will not be expected that I should relate all the particulars of my journey thither, as I retraced my former route with a few occasional deviations; I shall therefore confine myself to whatever I saw worthy of interest which I did not observe on my way to Tejuco.

Mr. De Camara did me the honour to accompany me as far as San Gonzales, and shewed me a work a short distance from the establishment, near the margin of a river of the same name. As I staid here one entire day with this gentleman, I had leisure to examine this singular situation, where I, for the first time, found mountains of sienite, incredibly hard, composed of hornblende and feldspar. About forty years ago this excavation, which was of considerable depth, was suddenly filled up by the bursting-in of the side, for want of proper support to resist the pressure of the incumbent stratum, which falling in immense masses, totally destroyed the works; and they remained in this state until about two years ago. As the wings of vague report are in general much longer than those of truth, this place had the reputation of being extremely rich in diamonds, and the apparent impossibility of clearing it, added greatly to the credit which was given to it. Old inhabitants came forward to say that

they had been employed in the works when the accident happened, and that the diamonds found in them excelled in number, size, and fineness those produced at any other place. These reports soon reached the ears of the Intendant, who, within a year after entering upon his office at Tejuco, formed a plan of clearing and excavating the works. Such a stupendous undertaking was calculated only for a man of his superior talents and enterprise. He stationed there four hundred negroes under the direction of the best officers on the establishment; inclined planes were formed, and pulleys calculated to lift immense weights were erected. As some of the masses of sienite were too large to be raised whole, and the substance was so hard that steel would not stand to bore it, they were obliged to contrive means for breaking them. Recourse was had to large fires, with which the rocks were heated, and cold water was thrown upon them from tubs suspended by long pieces of timber formed somewhat like cranes. After six months of very heavy and incessant labour, the place was cleared. Let us for a moment reflect on the sanguine expectations which had been formed respecting the size of the diamonds, their number and brilliancy, the honours that would be conferred on the officers, &c.; and we may judge what must have been the general disappointment, when, after the bottom had been scraped, not a diamond was found! Thus ended this serious trial, made at great expence, labour, and risk; like many other speculations, built on the delusive stories propagated by old miners respecting places formerly worked, by which new adventurers are tempted, and frequently ruined.

I continued my former route, visiting the same friends who had received me on my journey to Tejuco, until I arrived at Cocaes. In the vicinity of this place are found fine amethysts and crystals, through which titanium is interspersed. Proceeding from hence, I took a more easterly route to the village of Bromada, distant about five leagues. A great part of the road was covered with rich iron ore. I passed through the village of St. John, and

entered a fine valley, through which ran a little rivulet, called St. Antonio;—a more delightful place cannot be imagined: the grounds, which lay in gentle elevations, were capable of every kind of cultivation, and appeared calculated amply to repay the farmer for any labour he might bestow upon them. In addition to these advantages, and that of a fine climate, this vicinity yet contains some places extremely rich in gold. At the end of this valley we crossed the rivulet over a good stone bridge, and passed through a pretty hamlet called Barra; proceeding a league farther, we arrived at the house of Captain José Alvarez, who received me with great kindness. This being Sunday, many of the neighbours were on a visit to his house; a sumptuous dinner had been provided, and the evening passed in very interesting conversation relative to the mode of mining in that neighbourhood. Next day I went to visit the gold-works belonging to this gentleman, the principal of which was situated near the summit of a mountain of argillaceous schistus, one part of which seemed to have slipped from the other, leaving a cleft of twenty feet perpendicular. The face of this cleft appeared of different colours, some much more ferruginous than others; the parts esteemed most rich in gold had the appearance of irregular cavities, now filled by a substance not unlike ferruginous stalactite in decomposition. This mountain has produced a great quantity of gold, and continues yet rich: it may be truly called auriferous; for I directed negroes to bring me specimens of earth from every part of the cleft, from the roots of the grass to the bottom, all of which I found to contain gold. At this place stamps are used to reduce the indurated substances, but they are so ill-constructed as to produce but little effect. After a most pressing invitation to stay, and advantageous offers of land to a considerable extent, which I found it expedient to decline, I took leave of the owner of this establishment, and passed a very large house belonging to Captain-mor Penha, a very opulent miner, who has a large establishment of negroes, and extensive lands. I continued my route five leagues through

an auriferous country, passed the village of St. Barbara, and arrived at Catos Altos. From hence I proceeded to Villa Rica, without observing any thing worth notice.

I was here received with the same attention and respect which I had experienced on my first visit. Finding it necessary to remain here a few days to recruit my health, I examined a variety of substances that had been collected for me during my absence, but was not fortunate enough to meet with any thing very interesting. The theatre being open, I passed two evenings there, and was much gratified to find that the rational amusement of the drama had superseded savage bull-fights. The theatre and decorations were neat, and the performances tolerable; were they better encouraged, the public would receive greater gratification. They have ever been under the control of the governor, and are generally so fettered as to be obliged to perform such pieces only as his caprice may dictate.

Leaving Villa Rica, I continued my journey to the capital, where I arrived about the middle of February 1810, in a most exhausted state, from the combined effects of fatigue and an indisposition which continual exertion and want of rest had increased in a considerable degree. I informed His Excellency the Condé de Linhares of my arrival, and, in a few days afterwards, had the honour of presenting to him a report, stating the particulars of my journey. I was afterwards introduced to the Prince, who did me the honour to express his approbation of my account of the country through which I had travelled, and requested me to publish it. He was graciously pleased to make both my attendants officers, in reward for their good conduct; and when I expressed my thanks for this mark of his attention, he replied, that it was too trivial to notice, and desired me to name in what manner he could testify the sense he entertained of my services. At this moment my health was so extremely precarious, that I could not

think of remaining in Rio de Janeiro, where I found myself daily getting worse; otherwise I have not the smallest doubt that the generosity of the Prince would have amply repaid me for the fatigues I had encountered.

CHAP. XVI.

General View of Minas Geraes.

THE capitania of Minas Geraes extends from 600 to 700 miles from north to south, and about the same distance from east to west. It is bounded on the north by the capitania of Bahia; on the west by that of Goyaz; on the south by the river Paraibuna, which divides it from the capitania of Rio de Janeiro. It is separated from the district of Espiritu Santo and the coast by an immense chain of mountains, which country, being inhabited by the Anthropophagi, is of course very little known.

This capitania is estimated to contain three hundred and sixty thousand inhabitants, of whom two hundred thousand are negroes, or their immediate offspring. The population of Indians is not included in this estimate, nor can it be ascertained; they are considered as by no means numerous, as they never make any opposition against an armed force, however small. In the course of my journey I did not see one, except the child at the village of Concepção, nor did I ever hear of any of them becoming civilized, or living in any of the villages with the settled inhabitants*.

The regular military establishment of the capitania is very respectable, and consists of 1400 cavalry, which number is prescribed by

* From all accounts relative to the Indians, either by the officers employed against them, and better acquainted with their habits than other men, or from any of the settlers who live near the coast, it does not appear that they have the smallest knowledge of gold or of precious stones; hence they can in no degree have contributed to the discovery of those treasures in the district.

law, and cannot be augmented. Their principal station is at Villa Rica, where the general resides, who, jointly with the governor, issues all orders respecting them. They form a disposeable force for the general service of the capitania; they are appointed to guard certain places known to contain valuable products; also to receive tolls, collect tythes, patrol the roads, and search suspicious persons, for which purposes parties of them are stationed at the various guard-houses and registers. They go in quest of felons, guard the prisons, and likewise execute orders to impress men levied for service in Rio de Janeiro. They are employed exclusively in the mining country, which they never quit, except when they escort diamonds and treasure to the capital, or are dispatched on any particular service. The regiment is a very fine one, and enjoys so high a reputation, that numbers are continually offering to enlist in it. While I was at Villa Rica nearly two hundred volunteers were serving, without any remuneration whatever, waiting to be placed on the establishment according to their seniority, as vacancies should occur. This affords the general an opportunity of choosing the most soldier-like men, and those of best character, in which respects it is asserted, and I believe with great truth, that the corps is unrivalled. The officers enter very young, and serve as cadets for a certain period, during which they perform the duty and receive the pay of privates, from whom they are distinguished by a star on the right shoulder, and generally exercise together. They are promoted according to seniority.

Besides this force, there is a militia, in which all the male inhabitants of the capitania are enrolled, and are liable to be called out when occasions require. It is a part of the present policy of the Prince's ministers to stimulate the Creolians to active occupations, by obliging them either to till their grounds, or to enter the ranks and become soldiers.

The known produce of this vast extent of territory comes next under consideration. On this subject I shall not follow a variety of

vague accounts, which have been compiled with little regard to truth, but shall present to the reader the result of my own observations.

The great quantities of gold, precious stones, iron, &c. produced in this country have been largely treated upon. Galena, or sulphuret of lead, is found only near Abaitè. Antimony abounds in the vicinity of Sabara; native bismuth is found near Villa Rica; arsenical and martial pyrites are very common; titanium is found in octaedral crystals, also in beautiful prisms and tender spiculæ, finely grouped in rock crystal. Platina may be obtained in tolerable quantities at Largos, but the place which produces it has been abandoned from want of a market. Chromate of lead, I was informed, is found in the vicinity of Coaes: I saw several pieces in the possession of Dr. Gomedez of that place. At Tejuco, also, I was shewn some, and was presented with two pieces, which are uncommonly fine, more brilliant in colour than that from Siberia, and distinctly crystallized on a matrix of granular sand-stone, accompanied with the green oxide of chrome. Copper can scarcely be said to exist in this country; the only place at present known to produce it, is a mountain twenty leagues from Tejuco, where small particles appear in a rock of quartz and hornblende: the matrix is so hard, and the quantity of copper so trivial, as to afford no encouragement to work it. The place has been examined by the Intendant, and is known to most persons in Tejuco*. No mines of silver have been discovered in the capitania, but the gold is generally found to contain that precious metal, sometimes in great proportion. No tin, cobalt, or any other metal, except those above mentioned, has been hitherto met with.

* At a place called Caldrones, near to Oro Branco, I received two bits of this metal, but they were so small and disfigured, as to leave strong doubts respecting their being natural; the more so, by reason of the many impositions that were attempted to be practised upon me by false specimens of copper ores, silver, &c.

Of salts, impure nitrate of potass is formed in great abundance, generally, if not always, in calcareous situations, in a tract of country which commences from ten to fourteen degrees west of Tejuco, particularly at Monte Rodrigo, which is situated between the two celebrated rivers called Rio dos Velhos and Parauna. This mountain is very large and well-wooded; the stratum is calcareous, and contains many caves furred, as it were, with nitrate of potass. Since Government has made nitre an object of commerce, and encouraged its production, many families have settled at this place, and have collected large quantities of this saliferous substance, which, after several operations, is sent to Rio de Janeiro, where it is refined for the great powder-manufactory recently established near that city.

In various places are found the finest clays in great plenty, fit for porcelain and earthenware of every description, which are entirely neglected. In other parts I saw cyanite, actinolite, tremolite, potstone, and chlorite. Conglomerate masses of recent formation, enveloping diamonds and grains of gold, are sometimes, though rarely, met with; also a siliceous substance of a fine dark-blue colour, probably totally unknown.

On the vegetable products of this capitania I have but few observations to make, in addition to those already given in the course of my narrative. Many parts are well calculated for the growth of hemp and flax, and water for steeping them is easily attained in most situations; so that the only impediment to the introduction of these useful plants appears to be the labour required to clean them.

In the immense woods the finest trees are frequently destroyed by the creeping plants, which cannot grow without adhering to some support. When they attach themselves to a tree, they shoot up very rapidly, encircling it with numerous fibres, and in a few years become so strong as entirely to stop the growth of the tree, and at length destroy it. When in a young state, they are so flexible as to be used for ordinary purposes instead of cords. I have seen negroes make their bridles of them, and ride with them for a day together.

As these forests remain unexplored, many of the trees are unknown, and consequently the qualities of their barks. However, there are some used by the inhabitants in dyeing yellow; and I was informed some yielded a black colour that could not be washed out. There is a variety which serves for curing skins, or tanning, some of which give the hide a red colour, others leave it almost white: but this art is so little known, and the people are so averse to employments of this sort, that it has hitherto made little progress.

Gum tragacanth is in great plenty, and of a very good quality. There are immense quantities of aromatic shrubs; and I found in many places upon the bark of trees, and more particularly upon old wood, a lichen, which yielded to water a most beautiful crimson colour*. Jointed canes grow spontaneously, frequently above thirty feet long, and in many places form arcades over the road: these plants always indicate the soil to be very fertile.

Ferns grow so large, as almost to lose their characteristic: I have frequently seen them twelve feet high. These and other succulent plants, when reduced to ashes, serve to make soap, of which almost

* A part of the lichen which I brought home with me I presented to a gentleman who was fond of chemical experiments: he obtained from the small quantity of three grains as much colouring matter as imparted to an ounce of fluid a deep purple, sufficiently strong for every purpose of dyeing.

The following are the results of some experiments which he did me the favour to make:

White sewing-silk, put into an alcoholic solution only once, received a fine strong purple.

Part of a skein of the same material was put into a solution of potash, which produced a purple deeper in hue than the former.

Cotton thread and worsted yarn, immersed only once in the same solution, produced very nearly the same colours.

The part of a skein of silk dyed in the alcoholic solution was immersed in a solution of muriate of tin, which produced a beautiful lilac, approaching to dove-coloured blue. The same substance dyed in a solution of potash, and immersed in a solution of muriate of tin, became a few shades darker, and rather more of a pink hue. These are not unfavourable results from a quantity so minute; and I feel confident that this substance may be rendered a very valuable article of trade.

every negra knows the process, and most families make for their own use. It is very sharp, and washes white articles uncommonly well*. In this fine country, where almost every gradation of climate may be found, European fruits, such as olives, almonds, chesnuts, mulberries, &c. would thrive, if properly attended to.

The mulberry is cultivated at one place, where I saw a few silkworms. The climate is favourable to them, but the population is not sufficient to carry the breeding of them to any extent, as they require great attendance and care.

Cochineal may be said to be almost unknown in the capitania; the *palma Christi* grows spontaneously, and from its seeds great quantities of castor oil may be extracted. For bananas and other tropical fruits the climate is not sufficiently hot, and is too changeable. Beans, peas, and pulse in general, are very fine; pumpkins also, and cabbages grow to a great size. It is a fine country for flowers; the rose is extremely fragrant, and is in bloom all the year. Varieties of the passion-flower are found in all parts; pinks and carnations, with numberless other flowers, grow in great profusion.

This capitania contains four comarcos, or districts, St. João del Rey, Sabara, Villa Rica, and Cerro do Frio, all of which produced much more gold a few years after their discovery than at present, though in the year 1809 Villa Rica alone received for gold permuted a hundred and six arrobas of thirty-two pounds each. The mines in the other three comarcos cannot be rated to permute less than from fifteen to twenty arrobas, therefore the capitania may be estimated to yield to Government, as the annual fifth, a quantity not less than one hundred and fifty arrobas.

St. João del Rey, the capital of the district so called, is a considerable town, and contains at least five thousand inhabitants.

* In many parts of the coast, the plant which produces the barilla would probably flourish abundantly, if introduced, and would form an excellent article of commerce, not only for exportation, but for home consumption.

It is situated near the Rio das Mortes, which runs northerly, and empties itself into the Rio das Velhas. The country around it is very fertile, and produces excellent fruits, both exotic and indigenous; also Indian corn, and beans in great quantities; a little wheat, &c. This comarco being more cultivated than any other part, is called the granary of the district; cheese is made here in tolerable quantity, and bacon very indifferently cured, both which are sent to Rio de Janeiro, and form a considerable trade. Great numbers of fowls are also sent thither, and a little rum, sugar, and coffee. Provisions of all kinds are much cheaper than at Villa Rica; pork and beef are about a penny per pound, poultry in proportion, and vegetables equally cheap.

About two leagues distant from the town is the rivulet of San José*, formerly abounding in gold-washings, some of which continue good, particularly those in the vicinity of a pretty village, called Campanha. In the neighbourhood is a mountain that produces a great quantity of iron pyrites, which many people believe to be gold, and say that no method is yet known for extracting it. In this district are a great number of pines of a very singular variety, from the bark of which exudes much resinous gum. The wood is of a fine brown-red colour, full of knots, and inconceivably hard.

Some cotton, although not very considerable in quantity, is grown in this district; it is spun by hand, and woven into coarse clothing, generally for the use of the negroes. Finer cloth is sometimes woven for table-linen. The making of lace is a favourite occupation with the ladies of St. João del Rey, who are reputed to be more attentive to domestic concerns than those of other towns, many of them being descendants of the Paulistas, so celebrated for industry and economy.

The district of Sabara was discovered and settled by the Paulistas, who took possession of it as early as the year 1690, or, according to some accounts, twenty years earlier. They founded the town which is now the capital of the district, and worked several gold-mines in

* There are several rivulets in various parts that bear this name.

its neighbourhood, the produce of which they sent to their native place, as it was their custom to do with all the gold found in the various parts which they explored; on this account the city of St. Paul's acquired a much higher reputation for riches than it merited, it being generally believed that all the gold sent from thence was procured in that vicinity. Some years after the establishment of Sabara, the Court of Lisbon sent out a nobleman as governor to reduce the settlers, and to oblige them to pay a tribute in conformity to the laws of the colony. The settlers took up arms, and several encounters took place, in one of which the nobleman was killed: but, after some time, the viceroy sent great reinforcements into the interior, and quelled the insurgents, who submitted to pay a fifth of the gold produced. A person of the name of Artis, who was a man of great intrepidity and perseverance, and had made considerable discoveries in the neighbourhood, was afterwards appointed governor, and this proved the means of reconciling all parties.

While the Paulistas remained within their own territory, they were not, in any instance of which there is record, inimical to Government: but after they had formed a large settlement, and were become populous, they were not contented with living in as fine a climate and as fertile a soil as imagination can conceive, but began to migrate in search of gold, traversing unknown countries, and encountering every species of fatigue. When they had explored and occupied rich districts, at the expence of many lives and indescribable hardships, it is not a matter of surprise that they should be desirous to maintain their right to them by every means in their power. These enterprising men were the only active adventurers in the colony; they knew their own superiority to the rest of the inhabitants, and a sense of it inclined them to oppose Government, who failed not to bestow upon them epithets which they little deserved. It is well known, however, that, in the colonial war of 1770, the troops of the Portugueze government would have made but a wretched figure without the Paulistas in the Paraguay, and the very extensive terri-

ories in Matto Grosso, and to the north-west, where they penetrated and formed settlements, almost in Peru. They acted as cavalry only, and in a manner peculiar to themselves, which was so full of stratagem and surprize, that the Spaniards were generally driven, panic-struck, from their possessions. Their exploits are recited with enthusiasm by their descendants, who, ever remembering the prejudices which the Spaniards entertain against their nation, ardently desire an opportunity of emulating their ancestors. In the war above-mentioned, the Portugueze troops, under Captain Coimbra de Suara, took in an instant the important settlement of Rio Grande de St. Pedro, which yet remains in their possession; and it is thought that the whole territory on the north side of the Plata would be a very easy conquest, which the Paulistas alone would gladly volunteer to accomplish. I cannot conclude this digression without observing, in contradiction to the opprobrium and calumny bestowed on these men, and the false charges of discontent and rebellion which have been brought against them, that the Prince has not more loyal subjects in any part of his dominions.

Respecting the working of the mines throughout this capitania, it has been already observed, that much loss of time and labour is occasioned by the want of machinery, and proper implements for the workmen. Not a cart or wheel-barrow is in use: every thing necessary to be removed is carried on the heads of the poor negroes, in gamellas, who have in many instances to climb up steep ascents, where inclined planes might be employed to great advantage, and would be formed with very little trouble. The caisson is the only hydraulic machine known, and is very generally adopted: but it is constructed with great difficulty and expence, and can be used only where a strong current of water can be commanded. Pumps might, at very trivial expence, be constructed on the plan of the machines used to pound their Indian corn.

The tedious process of washing the cascalhão for gold in gamellas, would be much shortened by using the machine of which the follow-

ing is a description:—Suppose a cylinder to be formed of bars of iron longitudinally placed, and nailed to circles of wood, open at each end, and suspended on two centres, one about sixteen inches higher than the other. At the highest end the cascalhão is to enter by being put into a hopper which communicates with it. The bars must be nailed almost close to each other at the upper end, gradually widening to the lower end, where they should be about half an inch asunder. The cylinder ought to be from ten to fifteen feet long, and a stream of water conducted to fall upon it length-wise: it should be inclosed, like a dressing-machine in a flour-mill, and be subjected to a very quick motion. The portion of cascalhão containing the most gold will by gravity fall through near the upper end; the other parts, according to their comparative fineness, gradually descending until nothing but the pebbles fall out at the lower end. The earth and ferruginous oxide, falling into partitions or troughs below the cylinder, would be ready for being purified or separated from the gold by hand, which might be done with very little trouble.—Machines of this kind might be made on any scale, and, if generally known and adopted, would save the labour of the negroes in a ten-fold degree. The one constructing in Cerro do Frio will, when complete, do more work than a hundred negroes in the same space of time. A considerable improvement might yet be made in this useful apparatus; for, if the gold, &c. washed from the machine were to fall upon troughs placed in an inclined position, having a channel across about a yard from the upper end*, all the gold would precipitate into it, and, if a negro were to be continually employed in agitating the water, the earthy matter would run off, leaving only the gold and the ferruginous particles; which might be easily separated by mercury†. The utility of machinery of this kind is too obvious to need pointing out.

* If necessary, another channel might be made at a convenient distance from the first.

† It cannot be too much recommended to Government to introduce the process of amalgamation generally throughout the mines.

Machinery used in Brazil.

Machine called a Sloth.

p. 134.

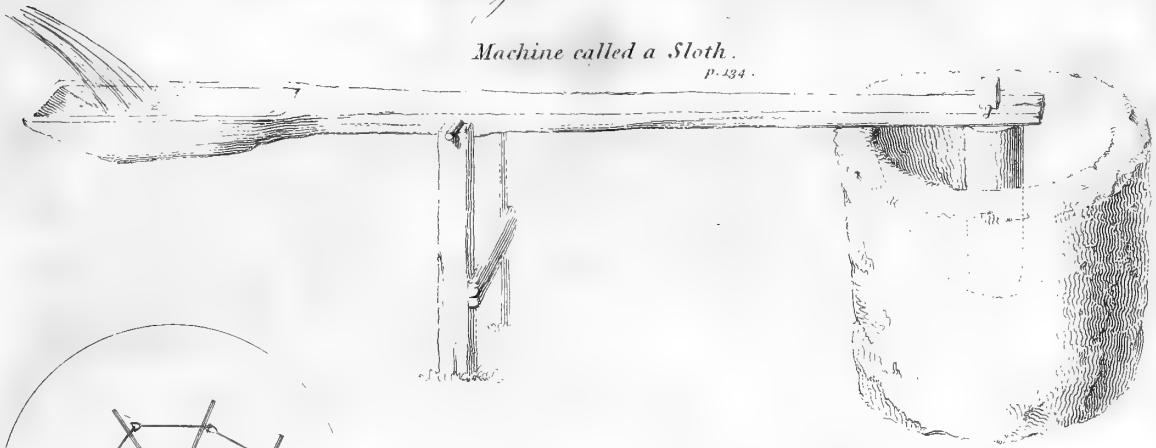

Hydraulic Machine.

p. 185.

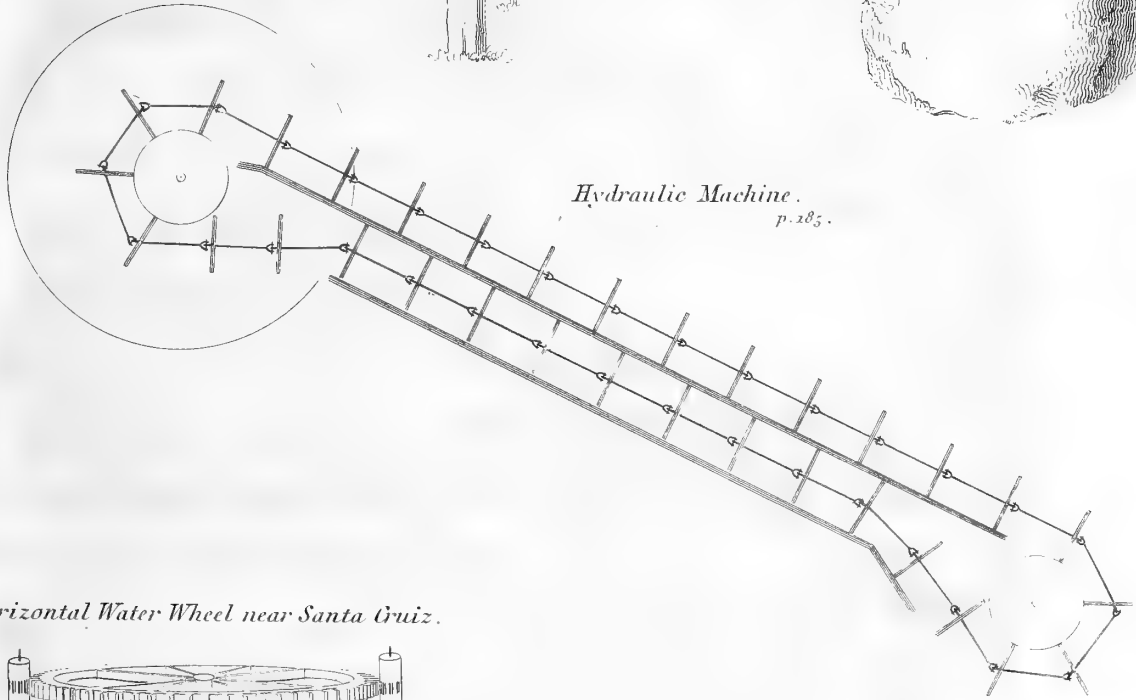

Horizontal Water Wheel near Santa Cruz.

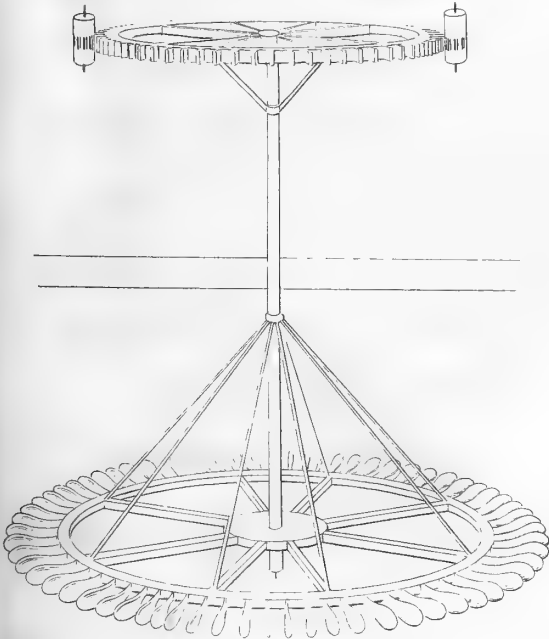

Cylinder for washing the Cascalliao.

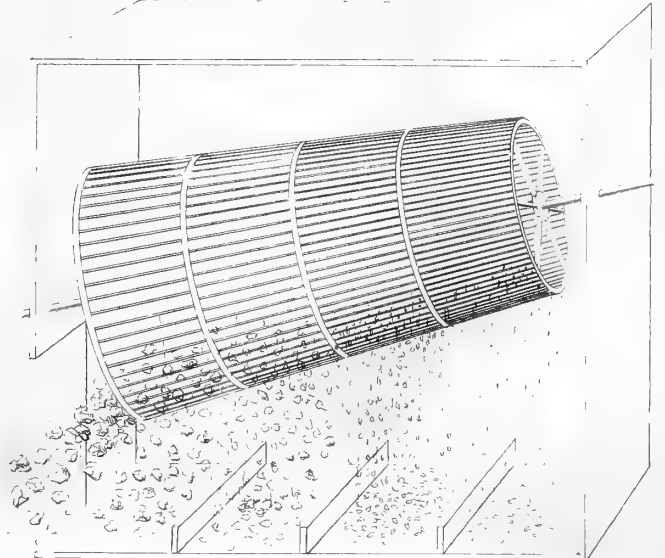



Mills composed of three heavy irregular stones, resembling our flint-mills, would reduce many of the ferruginous cementations and softer substances which contain gold. The matter thus reduced might be immediately washed by falling or being put into the inclined planes before described, and would, no doubt, prove the means of obtaining considerable quantities of the precious metal, which would be otherwise lost. Stamps might be useful where gold is found in hard and brittle substances: but these might be more effectually pulverized by a heavy stone rolling upon its edge, not unlike a tanner's bark-mill.

In many instances, hand-sieves might be useful, and would save much time and labour in washing, but perhaps they would be too expensive. Even miners' tools are much wanted, the only ones in use being the iron bar and the hoe. The common miner's pick-axe would in many cases be serviceable, and *bucking-irons* would reduce the matrix much more effectually than beating it with stones, which is the only mode now practised. It is a most unfortunate circumstance, and very detrimental to the interests of the miners, that whatever is made of iron is so dear as to be beyond the means of the inhabitants to procure, nor have they any substitute for it.

When the present state of the mining country is considered, and its rich resources are compared with the want of science, which prevents the inhabitants from improving them, how much is it to be wished that Government would establish and encourage economical societies on the plan of our Society of Arts, Manufactures, and Commerce, in which inquiries might be made into all subjects relative to the useful arts. Repositories also might be established in all the principal towns of the capitania, where models of useful machinery and various implements might be kept for the inspection of the public. Scientific publications should be purchased, and every means employed to promote the cultivation of science among the inhabitants. At the meetings of the societies, every measure tending to increase the commerce of the district should be discussed

with particular attention ; honorary gifts should be made to those who most promoted its welfare, and premiums should be offered for the encouragement of all attempts to ameliorate the condition of the negroes. Although these poor captives are in general much better treated in Brazil than in many other colonies, yet their welfare is a consideration which ought always to be uppermost in the minds of the philanthropic. Among other subjects that merit the encouragement of such a society, are the growth of hemp and flax ; the improvement of the cotton, which of late years has been much neglected ; of coffee, which may be almost said to be unattended to ; and of rum, which is so very indifferent, and which, with better management, might be made so much superior. A better mode of farming might be introduced,—the culture of grass for cattle better attended to,—new modes of washing for gold and diamonds invented, that the negroes might work in an upright position.

Were such societies formed under the patronage of the Prince Regent, great improvements might be expected in every department of rural economy ; the country would be better cultivated, its mines would be worked to greater advantage, and many new productions, both mineral and vegetable, would in all probability soon be discovered. Through the influence of these philosophic meetings, information would be generally communicated, a spirit of enquiry would be awakened among the people ; they would learn to appreciate the blessings with which nature has enriched their country ; they would introduce the modern improvements of Europe ; as they became enlightened, they would become industrious, and would much surpass their neighbours, who would look up to them for instruction and example.

What objection can be made to a measure which promises to benefit alike the subjects and the state ? Even the most narrow-minded policy cannot find a pretext for keeping a whole people in ignorance ; for to be informed is to be useful, and every portion of knowledge imparted to them redounds to the interest of the govern-

ment. There can be no doubt that the present enlightened ministers of the court of Rio de Janeiro will endeavour to promote the sciences among a people so capable of attaining a proficiency in them, and of converting their acquirements to useful purposes. From the introduction of such a measure, might be dated a total change in the moral character and general habits of the Brazilians; instruction would be imparted to all classes,—emulation would be enkindled among them,—and useful knowledge, descending from parent to child, would soon be universally diffused. This would be the true foundation of the prosperity of the country; for no territory perhaps in the world is so rich in natural products, and at the same time so neglected for want of an enlightened and industrious population.

CHAP. XVII.

Brief Notices on the Capitania of Bahia, Pernambuco, Seara, Maranham, Para, and Goyaz.

THE capitania of Bahia, to the northward of Minas Geraes, comes next under consideration, respecting which, as I did not visit it, I have only to present some observations from the best information I could procure. It extends a considerable distance along the coast, being bounded on the north by the great river St. Francisco, which runs into the sea in lat. 11° south, and separated from the district of Ilheos (formerly a capitania) by the river Das Contas in lat. 14° south. It receives its name from the capacious bay on which its capital is built, and which affords excellent anchorage for ships of any burthen. St. Salvador, the capital, also called Cidade de Bahia, was originally the seat of the supreme government of Brazil: it consists of two parts, one built on low ground near the shore, where the commerce is carried on, and the other on a high hill, which being considered the most healthy, is the residence of all the people of consequence. Its population is said to be nearly equal to that of Rio de Janeiro, and is stated at not less than seventy thousand souls. The houses are built with latticed windows and balconies, similar to those in Rio de Janeiro. The churches are the public buildings most worthy of notice: they are said to be richly ornamented within. The government of the city is vested in a viceroy, or governor, who is nominated by the court for three years. Here all law proceedings, civil and criminal, come before the respective magistrates, whose sentence is in general final, though appeals in certain cases may be made to the court at Rio de Janeiro,

The town is tolerably defended, also the bay, as well as circumstances will permit. On the shore is a royal arsenal, and numerous houses for stores, &c. The custom-house and wharfs are conveniently situated. Ships of war have been built here, also many very large and fine vessels for the merchant service. For these purposes a large supply of fine timber was (and, I presume, continues to be) readily obtained from the interior from the number of fine rivers which flow into the bay. The wood holds iron better and is superior to our oak.

The manners and customs of the people differ little from those of the inhabitants of the capital; but it is said that in the best societies here, more gaiety and refinement prevail, and the higher classes are more sociable, than in Rio de Janeiro. A taste for music is general; there are few houses without the guitar, and all the more respectable families have piano-fortes. The ladies dress in the English style, and ornament themselves with gold chains: they wear very few diamonds; their favourite gem is the chrysolite. For deshabelle at home they wear a kind of loose dress, over which they throw a veil on the entrance of strangers. They are considered as far less industrious than the females of the southern districts. The domestic dress of the men consists of a jacket and loose trowsers, made of light printed cotton.

Religious processions take place here, as in Rio de Janeiro, on great festivals and rejoicing days; and these festive occasions are distinguished by various amusements, which continue from morning to night. At these times the Brazilians have a custom of covering the walls and balconies of their houses with beautiful silks made and ornamented for the purpose.

One of the most memorable seasons of rejoicing of late years was when the Prince touched at this city on his voyage to Rio de Janeiro, and remained several days. The inhabitants testified their loyalty and attachment to him by every public demonstration of joy, and by a display of all the grandeur and magnificence which they

had means to furnish. As a more solid proof of their attachment and regard, they unanimously voted to subscribe a sum equal to half a million sterling to build a palace for the royal family, if the Prince would condescend to reside among them.

The climate is always warm, but is refreshed by the sea-breeze, and is in some degree tempered by the long absence of the sun, the nights being of almost uniform length throughout the year. Though hotter than Rio de Janeiro, Bahia is considered much more healthful, having a more airy situation, and being better supplied with water. The practice of bathing is very general, and most of the houses have conveniences for this purpose.

Bahia is plentifully supplied with provisions. Beef and pork are in abundance; the former is decidedly bad, the latter tolerable. Fish are in great plenty and variety, and form a principal article in the diet of the inhabitants. Cold fish, with sallad, is the general supper of almost all ranks; even the rich desire nothing more for this repast in family. Numbers of retail shopkeepers, who sell wine, cheese, groceries, &c., buy fish and fry it, and afterwards retail it in small quantities. Poultry is in plenty, but not cheap; vegetables, and pulse of every description, are in very great profusion. The markets are well supplied with all the tropical fruits, many of which are said to be in great perfection, particularly the pine, the mango, and the banana; the latter is esteemed the best in America. Preserved fruits are in great abundance, owing to the cheapness of sugar; great varieties of them are sold in the streets, and two or three preserved limes in a cup of syrup may be bought for a penny. Even the lower orders conclude the meanest dinner with this delicious delicacy.

The inns, and houses for the accommodation of strangers, are as bad, if not worse, here than in any other part of Brazil. The owners are indifferent to the comfort of their guests, and, indeed, have no motive to be otherwise; for the Portuguese pay very poorly for bare necessaries, and generally go to the place where they can obtain them the cheapest.

The soil of this capitania is peculiar, and is esteemed the best in Brazil for the growth of the sugar-cane. This advantage, and the conveniences arising from the numerous rivers that flow from the interior into the bay, have occasioned the establishment of many sugar plantations, undoubtedly the finest in the country, which have produced immense quantities of that article. The soil most adapted to the plant, and held in the highest estimation, is a black greasy loam, apparently a deposition from the rivers, containing a large quantity of vegetable matter.

The mode of cultivating the cane has already been detailed. If planted in new soil, it is fit for cutting in fourteen months, but in old and poorer land it requires eighteen or twenty months. When ripe, the canes are cut and dressed by taking off the top leaves, &c., which afford excellent provender for cattle; they are then brought to the mill, which is composed of three wooden or iron cylinders, moving on their axes in a perpendicular position, and between them the canes are repeatedly passed until all the juice is expressed, and they are reduced to a mass of dry fibres.

The liquor is conducted through spouts to a large boiler or clarifier, where a certain quantity of alkaline matter, called *temper*, is added to it*. Afterwards it is conducted to the largest of a range of boilers, consisting of three, or sometimes four, one less than another. The largest seldom contains more than one hundred gallons. Here the syrup boils for a certain time, and is continually skimmed; it is then laded to the next, where it continues to boil until more of the aqueous fluid is evaporated; after which, it is laded into the third boiler, and is there sometimes sufficiently boiled without removing it into the fourth. They judge of its consistency by the touch; a little

* A lixivium of strong ashes is made, and a quantity of lime is put into the alkaline liquor: or sometimes the ashes are mixed with a larger proportion of lime, and the clear liquor running from the mixture is added to the fluid in various quantities, at the discretion of the negro who manages the process, without one ray of knowledge relative to its nature.

of the syrup is taken between the thumb and finger, and if it forms threads, and breaks on being drawn about an inch, it is supposed to be boiled sufficiently*. It is then gently laded into earthen pots of the form of a sugar-loaf, about two feet deep and ten inches in diameter at the open end, where, on cooling, it becomes concrete. In the lower end of each pot is a small hole, which at first is nearly closed; but after the sugar begins to cool, it is unstopped, and a piece of cane is put in to admit the molasses to drain. Soon after the moulds are filled, they are removed into an airy room, where they are placed so that the molasses drain into a large cistern, from whence they are conveyed into the fermenting vats, which are receptacles for all the refuse of every description in the sugar-house. In the process of fermentation much depends on the quality of the wood of which the vats are made; some of them bring the liquor into a proper state for distillation two or three days sooner than others.

The greatest part of the sugars made here are clayed, by a very simple operation, which consists merely in covering the sugar with very moist clay, the water from which percolates the mass, and carries with it the remaining molasses. When the earthy matter becomes dry, more is applied until the sugar is perfectly freed, and nearly white. After remaining in the drying-house about six weeks, the moulds are placed with the large end downwards, and the sugar-loaves leave them; they are then beaten down to powder in large strong cases, constructed of four entire planks, and the two ends, generally about eight feet long, and about twenty-six inches square†, holding from fifteen to sixteen hundred-weight. The cases, when filled, are nailed down, and are ready for shipping.

* In skimming, lading, and managing the syrup during the operation, the negroes display great dexterity.

† Large trees are cut into planks of these dimensions for making the cases, which are preferred to hogsheads.

The principal points to be attended to in making sugar are, first, that the canes be all ripe, and well cleaned from trash and leaves; next, that they be immediately crushed, and not suffered to lie in heaps to heat; and thirdly, that the rollers, and all the passages for the liquor, be well cleansed by washing as often as necessary. Respecting the *temper*, various opinions prevail; every negro has his peculiar mode of mixing and applying it. Canes that grow on some lands require more temper than those that grow on others, and a wet or a dry season will make considerable difference in the juice; but these facts are here entirely unknown, or very little attended to.

The middle parts of the sugar loaves being finer than the tops and bottoms, are by some houses kept separate, and sold at a better price. In almost every family they refine Muscovado sugar, when they wish to have some peculiarly white. The process is very simple, and is practised daily in the coffee-houses.

More sugar is shipped from Bahia than from all the other ports of Brazil united, and in general it is superior in quality; that from certain plantations is decidedly so. It is not, however, esteemed of so strong a body as our best from the West Indies.

The tobacco of this capitania is peculiar to it; and, by an exclusive privilege, no other part of Brazil was allowed to cultivate the same sort. It has given rise to much commerce, and has enriched many families. It was the most esteemed sort, not only in Portugal, but in Spain, and all her colonies, where it has been sold at great prices. Great quantities of it were consumed in Barbary; and on many parts of the coast of Guinea the demand for it was such that it was almost impossible to carry on trade for gold, ivory, gums, and oil without it. The mode of growing and manufacturing it is as follows:—First a good piece of ground is prepared, the finer dressed the better; the seed is sown broad-cast, and when the plants are about six weeks or two months grown, they are transplanted into ground prepared as before. In eight or ten months they arrive at their full growth, and when ripe the leaves are taken from

the stem, which frequently grows from four to seven feet high. They are laid upon the ground, or, in preference, upon any support which will preserve them from absorbing moisture, and admit a free circulation of air underneath. When they become in a slight degree withered, they are twisted with a strong winch, the end of one leaf uniting with the other, and the twist is coiled into a roll weighing from thirty to forty pounds. By this operation the juice of the leaf is expressed, which is viscid, and when oxidated becomes of a black colour, like molasses. The tobacco, after this last operation, is fit for commerce.

It is an object highly worthy the attention of the Portuguese government, to introduce other modes of curing tobacco. There can be no doubt that the soil and climate are congenial to it, and, were it properly prepared, it would probably equal any in Virginia, and become as great an article of commerce among the northern nations. Should such a measure be pursued, how many cargoes of this commodity alone would arrive in our ports, and from thence be distributed to the different markets of Europe!

Cotton has of late been grown here in considerable quantities, and has been sent to England at nearly the same price with that grown in Pernambuco, and its plantations are daily increasing.

Coffee is grown in great quantities, but is not esteemed so fine as that from Rio de Janeiro. Rice is produced in tolerable quantity, and its quality is superior: but the husk is so difficult to separate from the grain, that a great part is bruised in the operation, and is thus rendered of little value. The only method of cleansing it that has hitherto been practised, is by wooden pestles worked in wooden mortars, either by hand or machinery.

The beautiful dye-wood, called Brazil-wood, is shipped from this port and Pernambuco, of a quality much superior to that of Rio de Janeiro. This is one of the articles prohibited from general commerce, being the property of the royal household. Fustic in small quantities is brought from the interior.

The indigo made here is so far inferior to that imported from India as scarcely to be worth mentioning. It neither repays the planter for his trouble in growing and manufacturing it, nor the merchant who sells it. There is a general opinion among all who make indigo, that some part of the process is very prejudicial to the health of the negroes, who frequently become sick, and often die while employed in it. This effect cannot be produced by the labour, which is very light and trivial, therefore it is more probably owing to the gas which escapes from the leaves in fermentation.

The above are the principal articles of commerce produced in the district. Bahia has a considerable trade with St. Catherine's, and other ports on the coast, from whence are exported various articles that may suit the market, which is continually fluctuating. A great number of fine brigs and small vessels are employed in this trade.

Produce to a considerable amount was exported to the River Plata, from whence a great quantity of hides and tallow were returned; but the trade has never been so favourable as it appeared, on account of the great difficulty attending the payments. It is considered that the Spaniards in the River Plata are much indebted to the Portuguese.

The imports to Bahia from Europe consist in general of the same articles with those specified in the description of Rio de Janeiro.

Respecting the mineralogy of this capitania, I can say but little. It is well known to have produced the largest piece of native copper that has ever appeared, being in weight upwards of 2,000lbs. The piece was discovered several years ago by some persons who were preparing to wash for gold, but, contrary to the general laws of nature, it was found perfectly insulated, and not a vestige nor the slightest appearance of a vein of that metal was to be traced.

To the north of Bahia are the capitancias of Pernambuco, Seara, and Maranhã, the interior of which is very little known, though some parts of the coast are tolerably populous. Pernambuco, though situated nearly in the latitude of eight degrees, is considered healthy.

The town is built on a rising ground, much exposed, and constantly refreshed by the sea-breeze. It has many excellent edifices, and is supposed to contain more opulent merchants, in proportion to the population, than any other place in Brazil. It produces vanilla, cocoa, and a considerable quantity of sugar ; but the chief article of its trade is cotton, which for many years had the reputation of being superior to any other, but of late it has much deteriorated, from neglect, either in the growth, or in the gathering the pods and cleaning it from the seeds, or probably from general inattention to the whole management of it. In delicacy of colour and staple, it has been surpassed by the cotton called South Sea Island Georgia, of which great importations have been made to this country, and for which great prices have been given. The cotton, when ready for packing, is pressed into raw hides, so hard as to form very heavy packages. The operation is superintended by an officer authorized by Government, who puts a stamp upon it describing its quality, which enables the shipper to pass it through the custom-house, where it pays a small duty on exportation. This port has loaded many ships annually; and continues to export a considerable quantity, though at reduced prices, owing to the present distracted state of European commerce.

The district of Seara is but little known, and enjoys very trifling trade. Maranhão, though a very small district, has of late raised itself considerably into notice by its excellent productions, which are the same as those of Pernambuco. Cotton is the staple article, with some sugar and rice, several cargoes of which are annually exported.

The dye-wood of these districts is considered excellent, and is sometimes shipped from this coast. The tree which produces the annatto is very common, and the seeds from which it is washed are of the best quality, and might be obtained in great abundance. Cocoa may be grown in any quantity ; capsicum, pimento, ginger, &c. are very plentiful.

The markets are well stored with fish and meat, the latter very indifferent in its kind. Poultry, vegetables, and fruits are in great abundance.

St. Louis, the capital, is built upon an island, and is esteemed healthy, though so near the equator. Several rivers run into the bay, which afford an eligible conveyance for the produce of the vicinity. The island is said to contain 20,000 inhabitants, and the population in the rivers is by no means inconsiderable.

The capitania of Para is considered the largest in Brazil; its extent is imperfectly known. The principal town is called Belem, where the governor resides, and, its government being superior, it may be said to preside over several of the neighbouring districts. The land is low and unhealthy; the great river, or port, is much interrupted by shoals and currents. It is a dangerous coast, and exposed to a continual swell, so as to render it hazardous for ships to anchor upon it, as they roll so much that they not only endanger their masts, but are subject to strain.

The town of Para is situated on the river Tocantins, the navigation of which is difficult, and is seldom attempted, except by small craft: the Confidence sloop of war with great care sailed up it, and anchored near the town, several days previous to the expedition against Cayenne. The town may contain ten thousand inhabitants, who are in general very poor, probably from want of commerce; for although the great rivers Tocantins and Amazons have their source, the latter in Peru, and the former in the capitania of Goiaz,—though they receive almost millions of inferior streams in their course through immense tracts of territory, yet they are not productive of any commerce of consequence. The few exports from Para consist of a little rice and cocoa, a few drugs, &c. to Maranham, from whence they are embarked for Europe. A few small brigs were sent hither from Barbadoes, after the taking of Cayenne: but the trade must be a bad one, as the inhabitants are in general too poor to purchase English manufactures, except those of necessity; nor could the pro-

duce of Para be an object of interest, as a cargo is at all times very precarious, and difficult to be obtained.

The climate is hot, as may well be supposed, from its lying so near the equinoctial. Thunder, with lightning and rain, occur generally every afternoon, which cool the air very much, and render the heat less disagreeable.

On conversing with creditable men who had lived many years at Para, Maranhã, and upon the coast, I never heard them relate the strange accounts of the Indians which Estalla has related. As a Spaniard, he seems to be amusing the public with the actions of his own countrymen in Chili, and to aim, in common with all the writers of his nation, to prejudice the world against the Portuguese.

The capitania of Goyaz is bounded chiefly by Minas Geraes on the east, Matto Grosso on the west, and Para on the north. Its greatest extent in length is from lat. 6° south to 21° . Villa Boa, its principal town, is situated in lat. 16° south, about eighty leagues to the west of Paracatù, from whence there is a good road. Here is a permutation-house, where all the gold found in the capitania is permuted. The governor is elected for three years, after which he is generally appointed to Bahia or Minas Geraes. In the capitania are many gold-mines, some of which produce gold of a very fine quality. Diamonds have been found in some parts, which are different in their appearance from those found in Cerro do Frio, having more brilliancy on their exterior; but they are in general not of so pure a water, though of a very desirable size. As this fine district is so distant from the coast, it has very little commerce in any of its productions, except the valuable substances above-mentioned, and cattle, which are bred on the frontiers; also some cotton, and occasionally a few peculiar articles, which are sent to Rio de Janeiro. The mules on the return-journey are all loaded with salt, iron, cheap cotton-prints, woollens (particularly baizes), hats, fire-arms, powder and shot, and a variety of artificers' tools. When any of the inhabitants have any thing peculiarly precious to dispose of, they gene-

rally take it to Rio de Janeiro, and lay out the proceeds chiefly in the purchase of negroes, (they being at all times the first object,) iron, salt, and other commodities.

The population is very small in comparison to the extent of the district, but is likely to be increased by new settlers ; although the indigent in Villa Rica, Tejuco, and other places in the mining country, are little inclined to remove out of society, even for the chance of riches : in fact, having no negroes fit to work, and being totally destitute of exertion themselves, all situations are to them indifferent. These are by no means the class of people who can be styled adventurers. The poorer class of inhabitants who have obtained a small portion of gold, sometimes make a journey to Paracatù or Villa Rica to purchase what negroes they want. This capitania has been very little explored, and scarcely any thing is known of its productions beyond what is above stated, nor are any others sought after, though it cannot be doubted that there are many substances in all departments of natural history which might form the basis of a considerable commerce ; indeed, it is not unreasonable to presume that the soil contains the same variety of metals as the district of Mihas Geraes. Many persons from thence, with whom I have conversed, speak of it with delight as being a fine country, having numerous rivers well stored with fish, woods abounding with fine birds, which afford excellent diversion to the sportsman ; also a great variety of animals.

This capitania communicates with Matto Grosso, St. Paul's, and Para, by rivers which are navigable, though frequently interrupted by falls.

CHAP. XVIII.

Geographical Description of the Capitania of Matto Grosso.

RESPECTING this extensive portion of Brazil, I had an opportunity of gaining considerable information, being intimately acquainted with the commanding officer of the military force stationed there, Colonel Martinez, an engineer of extraordinary merit, who had made four journeys to Matto Grosso, and had resided there some years. He was kind enough to give me a description of his route from St. Paul's to the capital of that province, and promised me a chart of the navigable rivers and roads from thence to Para, which had been formed by officers of his party, together with documents in illustration of it. But he being hastily called away on a particular service, was prevented from executing his promise, and I could only profit by the verbal description which he repeatedly gave me. This description, as proceeding from a person of such undoubted veracity, it was my intention to give to the public; but, after my return to England, I was agreeably surprised to find a MS., nearly corresponding with it, in the hands of that eminent geographer, Mr. Arrowsmith, who has liberally permitted me to make use of it. To his excellent map, compiled according to the latest MS. charts communicated from Brazil, I beg leave to refer the reader for an accurate delineation of the particular localities here detailed.

This extensive capitania is separated from the neighbouring territory belonging to Spain by the intervening channels of the rivers Paraguay, Madeira, Mamoré, and Guaporé, which form a broad and natural trench around it of five hundred leagues in circuit, by means

of which, and by upwards of thirty rivers that empty themselves into it, a communication is opened through many and distant points with the interior of Brazil. This capitania, from its geographical position, has ever been considered as the grand outwork of Brazil, not only because it covers the interior divisions of this vast portion of the new continent, which is the cradle of its greatest rivers, branching in innumerable channels, and enriched with great and untouched treasures; but also because, by this extensive channel, the Portuguese are enabled to penetrate to the establishments of Spain in Peru.

The River Araguaya, or Grande.

The eastern boundary of the capitania of Matto Grosso, separating it from that of Goiaz, is the river Grande, two hundred leagues from Villa Bella. This river, known in the state of Pará by the name of Araguaya only, which is conferred on it by the numerous nations inhabiting its banks, has its remotest source in lat. 19° , and running north and south, intersected at various points by the meridian of $52^{\circ} 30'$, flows in lat. 6° into the Tocantines, wherein it loses its name; and both, thus united in one ample stream, continue their course for three hundred and seventy leagues, and fall into the southern estuary of the mighty river Amazons in lat. $1^{\circ} 40'$ between the two celebrated bays of Marapata and Limseiro, opposite to the great island of Joannes, or Murajo, and twenty leagues west of the city of Pará. — The river Das Mortes, which rises far to the west of the Rio Grande, and forms its highest western branch, running for a considerable space to the east, and afterwards north, with an entire course of one hundred and fifty leagues, till it enters the Araguaya in lat. 12° , is entirely within the capitania of Matto Grosso.

The river Araguaya is peopled by many tribes of warlike savages; it abounds in all the productions peculiar to the state of Pará, and affords an uninterrupted navigation from the city of that name, and by the river, with the centre of Brazil and the capitania of Matto Grosso. The same is practicable by the river Das

Mortes, and other western branches which enter the Rio Grande below. These branches, no doubt, contain unexplored mines; for there is no physical reason why gold should be found in the rivers that enter the Araguaya on the eastern side, (where, besides Villa Boa, are situated several villages belonging to the capitania of Goiaz,) and not likewise in the branches on the opposite side. It is positively known that the river Das Mortes is auriferous, and hence it is fair to conclude that the smaller streams which flow into it are much more so, for the nearer the source the greater is the quantity of gold found. The mines of one of its western branches were abandoned, not from the absence or scarcity of the precious metal, but because, being remote from the road, and in the midst of a swamp peopled by savages, the few settlers could not get conveniently supplied with arms, implements, and other articles.

In some of these mines gold above twenty-three carats has been found, but the greater part is only of 17, and of a green colour, being combined with a large proportion of silver.

The River Chingu,

the clearest, and one of the largest and most copious, branches of the Amazon, which it enters on the south side, after a course of three hundred leagues, in lat. $1^{\circ} 42'$, and long. 53° , seventy leagues west of the city of Pará in a direct line, but one hundred of navigation, is confined in a great part of its course to the capitania of Matto Grosso.

Its remote sources supply, not only the lands in which rise also the branches and rivers forming to the east and north the upper part of the river Cuiaba, but also that large space north of the river Das Mortes, intersected by the great road from Goiaz, extending as far as the river Porrudos. There is a tradition among the guides of the Sutaos* of Pirá and the Indians established on the banks of the

* Sutaò. This is a place understood to be uninhabitable for Europeans, being the residence of uncivilized Indians, and covered with almost impenetrable woods.

Chingu, that, after mounting the first large falls of this river, much gold was found in it, of which the Jesuits, those great explorers, obtained a large quantity. It is probable that the now unknown Minas dos Martirios, famous as the first discovery made by Bart^o. Bueno, and of which I have heard repeated mention in St. Paul's, exist only on some of the many branches that form the river Chingu. For this enterprising man, after having discovered those mines, returning to St. Paul's in order to engage negroes and provide implements for extracting those abundant treasures, which to this day continue to elude the searches of others, retraced his course; but passing by the mines of Cuiaba, which had been just discovered and were found wonderfully productive, he was there deserted by the greatest part of his followers. Fearing that he should lose the rest also, he turned eastward, and, in his anxiety to avoid the mines of Cuiaba, got still farther from those of Dos Martirios, until he lost himself in the immense wastes, wherein he wandered many months, and at length accidentally found the mines of Goiaz, which his father had before seen. These, like all the rest, proved very productive at the beginning.

This rich and new discovery soon diverted the attention of adventurers from the preceding; and the route to the Minas dos Martirios, together with their positive situation, have long been lost in a vague tradition of their existence. As the place was explored without the assistance of a compass, or any of the means necessary for defining its geographical position, there could not but prevail much doubt and uncertainty respecting it. Now there is no such discovery on the river Tocantins, which comprehends the whole capitania of Goiaz: the first account places it near a river, which indeed runs into the Amazons, like the Tocantins, but which was sought for passing near the upper branches, and west of the river Cuiaba, a situation in which the river Chingu alone is found; other explorers place it on the Araguay, which renders it useless to look there, for it is more than two hundred leagues north-west of the place

sought. This is substantiated by a fact of later date, which is as follows:—A grandson of Bart^o. Bueno, under the direction of an ancient journal of this discovery, describing the route to it, descended by the river Das Mortes, and entered some extensive plains on its western bank, on which he travelled westward for some days, when he arrived at a plain covered with white Mangaba trees, which were designated in the journal. From this place they had a sight of some detached high mountains between the north and west, three of which were of the figure specified, and indicated the situation of the Minas dos Martirios. An unexpected attack of the Indians, in which the chief and many others of the adventurers were killed, dispersed the party, and frustrated the object at the moment when it appeared to be already attained.

The river abounds in various products: cocoa is in plenty; there are some spices, and various indigenous fruits.

The River Tapajos

is the third which derives its copious sources, flowing through numerous large branches, from the capitania of Matto Grosso. It runs north between the Madeira and the Chingu for three hundred leagues, flowing into the Amazons in lat. $2^{\circ} 24' 50''$, and long. 55° , which is the geographical position of the town of Santarem, situated at its mouth one hundred and eighteen leagues from the city of Para, and one hundred and sixty-two by the shortest navigation. The river Tapajos rises in the plains of the Parexis, so called from an Indian nation which inhabits them. These plains occupy a vast space, not level, but formed by undulating heaps of sand and light earth, resembling large waves. The spectator who is in the midst of them ever sees before him a distant and extended mount; he advances towards it by a gentle and long declivity, traverses the plain, and advances by an ascent equally gentle until he gains imperceptibly the heights he saw; another eminence then presents itself, and he proceeds with the same recurring circumstances. The

soil of these wide plains is sandy, and so light that loaded beasts in passing sink into it so much as to impede their progress. The pasturage is poor, consisting of a grass composed of wiry stalks a foot high, and small rough lancet-shaped leaves; the animals in grazing pluck them up with the roots covered with sand; on this account the passage by land is difficult and tedious; though, on finding any of the streams, which abound in these plains, there is grass and other mild herbage, which afford tolerable pasturage. The plains of Paraxis form, to a large extent and breadth, the summit of those high mountains of the same name, and are situated on some of the most elevated land in all Brazil; for from them descend the two greatest rivers of South America,—the Paraguay, as well in its own numerous heads, as in its great and higher branches, the Jauru, the Sygotuba, and the Cuiaba,—and the Madeira, which is the largest river that flows into the Amazons on the south.

The Tapajos, flowing in a direction contrary to that of the above-named river, rises on these mountains. Its westernmost branch is the river Arinos, which intertwines its sources with those of the Cuiaba at a short distance from those of the Paraguay. The river Arinos has a western branch, called Rio Negro, from which, to the point where it is navigable, there is a passage of eight leagues over-land to the river Cuiaba, below its upper and greatest falls; and, in like manner, from the Arinos itself the passage to the same part of the river Cuiaba is twelve leagues.

The Arinos is auriferous at its springs, and in 1747 the mines of Santa Isabel were discovered in it, but immediately abandoned, as not answering the expectations created in those fortunate times by the great quantities of gold drawn from the mines of Cuiaba and Matto Grosso. The lands were infested by dangerous tribes of war-like Indians.

The river Sumidouro empties itself on the south side into the Arinos, and its source being a short distance from that of the Sygotuba, a large western branch of the Paraguay, there is an easy communication from

one river to the other. The famous discoverer, João de Souza Echevedo, in 1746 made this passage: he descended the river Cuiaba, and sailing up the Sygotuba to its very sources, he there passed his canoes over-land into the Sumidouro, which he navigated, following the current, notwithstanding that the river runs for some distance under-ground, and thence derives its appellation. After this, he passed into the Arinos, and thence into the Tapajos, where he surmounted the falls, though more difficult than those of the Madeira, and discovered many symptoms of gold in the river of Tres Barras, a western arm of the Tapajos, a hundred leagues below the springs of the Arinos. West of the Sumidouro, and in the plains of Parexis, the river Xacurutina has its origin to the north of the river Jauru: it is famous for a lake, situated in one of its branches, where every year is produced a great quantity of salt, which is a constant cause of war among the Indians. Some navigators make the Xacurutina an arm of the Arinos, and others of the Sumidouro. In these plains of Parexis, terminating to the west in the high mountains so denominated, which, extending two hundred leagues in a north-north-west direction, front the Guapore at a distance of fifteen or twenty leagues, springs the river Juruena, between the heads of the Sarare and the Guapore, a league east of the former and two west of the latter. This river, the largest and westernmost branch of the Tapajos, rises in lat. $14^{\circ} 42'$, twenty leagues north-north-east of Villa Bella, and, running north one hundred and twenty leagues, flows into the Arinos, and with it forms the bed of the Tapajos.

The Juruena receives on both sides many small rivers, those from the west affording many practicable communications by short passages over-land with the Guapore and its confluent streams. The uppermost of these, which is nearest to Villa Bella, is the Securiu, navigable even there, and almost to its source. This is a league north of the principal source of the river Sarare, which, a quarter of a league from its head, is three yards deep and five broad. Thus sailing up the Juruena into the Securiu, and making from its source the

short land-passage of a league to the Sarare, the navigator may reach Villa Bella in less than eight days, without any other obstacle than that of the fall formed by the Sarare, three leagues below its source, where it precipitates itself from the Parexis mountains on the western slope : this difficulty may be surmounted in detail, or by at once passing the four leagues, for the Sarare from its fall becomes immediately navigable to the capital of Matto Grosso. A league north of the source of the Sarare is the first head of the river Galera, the second confluent of the Guapore below Villa Bella ; and a league east of the same head rises the Ema, a western branch of the Securiu, affording equal facility of communication. The Galera has three other sources north of the first in the plains of the Parexis, all ample streams ; the last and most northerly, called Sabara, is distant little more than a league from the source of the river Juina, a large western branch of the Juruena. Thus, by the Juina and the Securiu, with a crossing of five or six leagues, so as to pass the falls of the Galera on the western scarp of the mountain, the Juruena may be connected with the Guapore.

Lastly, the Juruena may be navigated to its upper fall, which is within two leagues of its own source. The fall is formed by two small leaps, the river being, even in this part, thirty yards broad and of great depth ; from hence downwards it flows with great rapidity, yet its falls are not greater, and are more passable, than those of the Arinos. With the same circumstances, and by similar short land-passages, a communication is practicable from the Juruena with the rivers Guapore and Jauru, which are to the eastward of it, although these two rivers precipitate themselves from the south side of the Parexis mountains, where they rise, and immediately form numerous and extensive falls.

From the geographical position of the Tapajos, it is evident that this river facilitates navigation and commerce from the maritime city of Para to the mines of Matto Grosso and Cuiaba, by means of its large branches, the Juruena and Arinos ; if the short passages over-

land should be found troublesome to drag canoes, the goods may be forwarded immediately on mules. This navigation to Matto Grosso is at least two hundred leagues shorter than that performed through the Madeira and Guapore; it is consequently less tedious and expensive, and equally advantageous to the mines of Cuiaba. The navigation of the river Tapajos might lead also to new discoveries in the vast unexplored parts of this river, up to its entrance into the plains of the Parexis, and their products might add to those of the extensive regions on the Amazons. Besides this, the river is known to be auriferous for a great part of its course: it is known also, that, passing from the Juruena into its western arm, the river Camarare, and the heads of the river Jamary or Das Candeas, which, running in broad streams down the eastern side of the Parexis mountains, enters the Madeira, there are mines which have inspired great hopes, though but lately seen, after a fruitless search of twenty years.

The River Paraguay

has its remote springs to the west of the heads of the Arinos in latitude 13° , and, after a southern course of six hundred leagues, enters the ocean under the appellation of the Rio de la Plata. The heads of the Paraguay are seventy leagues north-east from Villa Bella, and forty leagues north from Cuiaba, and divided into many branches, and already forming complete rivers, which, as they run south, successively unite, and form the channel of this immense river, which is immediately navigable. To the west, a short distance from the main source of the Paraguay, is that of the Sygotuba, which disembogues on its west bank in lat. $15^{\circ} 50'$, after a course of sixty leagues. In the upper part of this river, and near its western branch, called the Jurubauba, was formerly a gold-mine, which was worked with considerable profit; but the superior advantages derived from others subsequently explored in Matto Grosso and Cuiaba, caused it to be abandoned, and its site is not now known with certainty. The little river Cabaral, also auriferous, enters the Paraguay

on the west side, three leagues below the mouth of the Sygotuba. On the banks of the latter lives a nation of Indians, called Barbados, from the distinction peculiar to themselves, among all the Indian nations, of having large beards.

The Boriras Araviras inhabit the banks of the Cabaral: they are a mixture of two different nations, who in the year 1797 sent four chiefs of their tribe, accompanied by their mother, to Villa Bella, in order to solicit the friendship of the Portugueze. The nation called Pararioné lives in their neighbourhood, close by the Sygotuba. A league below the mouth of the Cabaral, on the east bank of the Paraguay, is Villa Maria, a small and useful establishment, founded in 1778. Seven leagues south of Villa Maria, and on the west bank of the Paraguay, the river Jauru disembogues into it in lat. $16^{\circ} 24'$. This river is remarkable for the boundary-mark erected at its mouth in 1754, as well as for being entirely Portugueze, together with the lands on its south bank, and bordering on the Spanish possessions. It rises in the plains of the Parexis in lat. $14^{\circ} 42'$, and long. $58^{\circ} 30'$, and running south to lat. $15^{\circ} 45'$, the situation of the Register of the same name, it there turns to the south-east for thirty-four leagues, till, by an entire course of sixty leagues, it reaches its junction with the Paraguay. There are salt-water-pits, which in part have supplied Matto Grosso ever since its foundation with salt: they are in the interior of the country, seven leagues from the Register, and extend to a place called Salina de Almeida, from the name of the person who first employed himself in these works.

These salt-pits are situated along the margins of broad marshy bottoms, in which are found fish of the same kind with those in the Paraguay. The Salina de Almeida is not far distant from the bank of Jauru, and the great quantity of saline liquid found in it continues three leagues further to the south, where a junction is formed with another from the west, called Pitas, westward of which are high and dry plains, where are found numerous large circles, formed by a species of palm called Carandas. These plains terminate nine leagues

west of the Salina de Almeida, in a large pool or marsh, called Paopique, which runs to the south.

The confluence of the Jauru with the Paraguay is a point of much importance : it guards and covers the great road between Villa Bella Cuiaba, and their intermediate establishments, and in the same manner commands the navigation of both the rivers, and defends the entrance into the interior of the latter capitania. The Paraguay from this place has a free navigation upwards, almost to its sources, which are scarcely seventy leagues distant, with no other impediment than a large fall. These sources are said to contain diamonds.

The mark placed at the mouth of the Jauru is a pyramid of beautiful marble, brought to this distant point from Lisbon. It bears inscriptions commemorative of the treaty between the courts of Spain and Portugal, by which the respective territories, of which it stands as the boundary, were defined.

The lofty chain of mountains, which extends from the sources of the Paraguay near its eastern bank, border the river opposite the mouth of the Jauru, and are terminated seven leagues below it by the Morro Excalvado in lat. $16^{\circ} 43'$. Eastward of this mount or point all is marsh, and nine leagues below it there flows into the east side of the Paraguay a deep stream or river, called Rio Novo, discovered in 1786, which may hereafter afford a navigation to near St. Pedro del Rey, when the aquatic plants that obstruct its channel are removed. The most distant sources of this river are the rivulets of Sta. Anna, Bento Gomez, and others which cross the great road of Cuiaba to the west of Cocaes. In lat. $17^{\circ} 33'$ the west banks of the Paraguay become mountainous at the north point of the Serra da Insua, which, three leagues to the south, makes a deep break to form the mouth of the lake Gaiba. This lake extends westward, and there is a broad canal of four leagues in extent, which comes from the north, communicating from the above lake to that of Ube-rava, somewhat larger than the Gaiba, situated exactly contiguous to the Serra da Insua, on its north side. Six leagues and a half

below the mouth of the Gaiba, and opposite this mountainous bank of the Paraguay, is the mouth of the St. Lourenço, formerly called Porrudos. Twenty-six leagues above this the river Cuiaba enters its western bank in lat. $17^{\circ} 20'$, and long. $57^{\circ} 5'$: these two rivers are of great extent; that of Lourenço has its sources in lat. 15° , forty leagues east of the town of Cuiaba, receiving (besides the branches crossed by the road from Goiaz) other great streams on its east side, such as the Paraiba or Piquiri, which receives the Jaquari and the Itiquira, all of moderate size, and navigable. The Itiquira has been navigated to its heads, from whence the canoes were dragged overland to the Sucuriu, which falls into the Parana four leagues below the mouth of the river Tiete on the opposite side. The rivers Itiquira and Sucuriu were found to have fewer and smaller falls than the Taquari, and the land-passage is much shorter and more convenient than that of the Camapuão, so that this navigation is preferable to that by the two last-mentioned rivers: it is attended by only two obstacles,—many Indians, and a want of provisions.

The navigation to the town of Cuiaba by the river of that name, from its above-mentioned confluence, is short and easy: in the first ten leagues, after passing the two small islands of Ariacuni and Tarumas, occurs a large plantation of bananas, formed on an embankment on the east side of the river. Three leagues above this place the Guacho-uassu enters the Cuiaba by its east bank, and on the same side, seven leagues farther, the Guacho-mirim. From this point the river winds in a north-north-east direction, eleven leagues to the island of Pirahim, and from thence makes a large bend to the east, receiving numerous streams, and passes the town of Cuiaba, which is situated a mile to the eastward of it. This town is ninety-six leagues to the east of Villa Bella, and the same distance from the confluence of its river with the Paraguay. It is large, and, together with its dependencies, may at present contain 30,000 souls. It is well provided with meat, fish, fruits, and all sorts of vegetables, at a much cheaper rate than at the sea-ports. The country is well

adapted for cultivation, and has rich mines, but in some places little water to work them in dry weather. They were discovered in 1718, and have been estimated to produce annually above twenty arrobas of gold of extremely fine quality.

Twenty leagues south-west of the town of Cuiaba is the settlement of St. Pedro del Rey, the largest of all the adjacent settlements, and contains full 2,000 inhabitants. It is situated near the western side of the rivulet Bento Gomez, which, at the distance of a league and a half south of the settlement, forms a large bay, called Rio de Janeiro. The river Cuiaba has its sources forty leagues above the town, and its banks are cultivated through the greater part of its extent, including fourteen leagues below the town, down the stream. Four leagues below the principal mouth of the river Porrudos, the Paraguay is bordered by the mountains that separate it from Gaiba on its western bank, and in this place they obtain the appellation of *Serra das Pedras de Amolar*, from being composed of a stone of which whet-stones are made. This is the only spot which is not inundated by the floods of the river, and is therefore much visited by the canoes that navigate it. These Serras terminate two leagues to the south in those of the Dourados, immediately below which there is a channel on the west side of the Paraguay, which, piercing between two high detached mounts, called Cheines, leads to the lake Mendiuri, six leagues long, and the largest on the Paraguay.

From the Dourados the Paraguay runs southward to the Serras of Albuquerque, where it touches directly on the northern point, on which is situated a town of that name. These Serras form a compact square of ten leagues, and contain much calcareous stone; the land is considered the best on either side the Paraguay, from the river downwards, and only equalled by that on the western margins of the lakes Mandiuri and Gaiba. From Albuquerque the Paraguay turns to the east, skirting its Serras, which terminate at the end of six leagues in the Serra do Rabicho, opposite which, on the north bank of the river, is situated the lower southern mouth of the

Paraguay-mirim. This is an arm of the Paraguay, which, terminating here, forms an island fourteen leagues in length from north to south: it is the usual channel for canoes in times of inundation. From the mouth of the Paraguay-mirim the river takes a southerly direction to the mouth of the Taquari, navigated annually by flotillas of canoes and other craft, which come from St. Paul's to Cuiaba, and even as far as the Register of Jauru, when their destination happens to be Villa Bella.

As this navigation is an object of great importance, from its connecting two distinct districts, the following compendious description of the route pursued in it may not prove uninteresting. It is abstracted from the diary of a man of science, who performed the journey a few years ago, in the month of October, when the Paraguay begins to retire to its own channel. The description may commence at the Taquari, as the voyage from thence to Cuiaba and the Jauru has already been detailed. The largest of the many mouths of the Taquari in the Paraguay is in lat. $19^{\circ} 15'$, and long. 54° . In the first ten leagues of navigation, the channel of the river is lost, as it crosses some large plains, covered with water to the depth of several feet. This is contiguous to Taquari, a place where the river is much confined.

From this place it is twenty leagues to the resting-place of Allegre, in lat. $18^{\circ} 12'$, and this space contains, on both banks of the Taquari, many entrances into the paths, which lead in time of the floods to various distant places on the Paraguay, Porrudos, and Cuiaba. From this resting-place there are thirty leagues of navigation, on the course of the river east to the fall of Barra, where it is impeded and unnavigable above a mile, though a part of it may be passed in half-loaded and part in empty canoes. At the head of this fall the river Cochim enters the Taquari, and the navigation here quits the latter for the Cochim. At its mouth it is twenty fathoms broad, and a league upwards receives on its south bank the Taquari-mirim, a river nearly as broad as itself. A little above this confluence is situated its first fall, which is called *Da Ilha*,

and may be passed in empty canoes. A league above is the fall of Giquitaya, passed with half cargoes, and a league and a quarter farther, that of the Choradeira, the current of which is very rapid. Beyond this is the fall of Avanhandava-uassu, where the cargoes are carried over-land for half a mile, and the canoes are conducted through a difficult channel of three fathoms, at the end of which they are pushed over the rocks in order to pass the head or cataract. Half a league above is the fall Do Jauru, so called from a river of that name, which enters the Cochim above it, on the north side. From this confluence upwards there occur seven falls in the course of five leagues and a half, in the midst of which distance the river cuts and is enchannelled in a mountain, through which it runs smoothly, although scarcely five fathoms broad, and receives on its south side the stream of the Paredão, which is said to be auriferous. Half a league above the last of the seven falls before-mentioned are three successive ones, called *Tres Irmãos*, and at an equal distance above them, that of Das Furnas, which is passed laboriously with canoes unloaded. From this place the navigation continues on the Cochim through a succession of falls, until that river is joined by the Camapuão, eight yards in breadth at its mouth. From this point to its junction with the Taquari, the course of the Cochim is thirty leagues.

The river Camapuão, along which the navigation is continued, becomes narrower on passing some rivulets that flow into it, and so shallow, as to be in general scarcely two feet deep, and the canoes are rather dragged than navigated along its sandy bed. After two leagues of this labour, they quit the Camapuão-uassu, leaving it on the right hand, choked with fallen trees, &c., and enter into the Camapuão-mirim, up which they proceed one league, when they reach the fazenda, or estate, of the same name. This is an important establishment, belonging to the Portugueze, in the centre of those vast and desert regions that intervene between the great rivers Paraguay

and Parana, ninety leagues south-south-west, in a direct line from the town of Cuiaba. The place seems very proper for a register, to prevent the smuggling of gold in this route, and to fix the duties on goods passing to Cuiaba and Matto Grosso. The canoes and cargoes are transported from the Fazenda de Camapuão by land about a mile to the river Sanguixuga, the principal source of the Rio Pardo. From the end of the land-passages the navigation continues down the Sanguixuga, and, in the interval of three leagues, they pass four falls to the Rio Vermelho (so called from the colour of its waters), which enters the Pardo. Half a league from the mouth of the Vermelho the Pardo has the fall of the Pedras de Amolar, and a league below receives on its south side the river Claro, from which, after proceeding two leagues of level stream, there occur nine falls in the space of two leagues more. The passage of them occupies twelve or fourteen days in going up the river, though only one returning. Below the last of these, called the Bangué, the river Sucuriu enters the Pardo on its south side. Three leagues below the mouth of the Sucuriu is the cataract of Curare, about eight yards high, to avoid which the canoes are hauled over-land, through a passage of a hundred yards. From this cataract, in the space of ten leagues, there occur ten falls, which occupy fifteen or twenty days, in ascending the river, though only one in descending. The breadth of the Rio Pardo in this part is twenty-two fathoms. Two leagues below the last of these falls is a deep inlet of three hundred and ninety fathoms; half a league lower the canoes are hauled over a space of land of a hundred and fifty yards. Half a league further is the fall of Sirga Negra; one league further, that of Sirga Matto; and a little more than a league from thence, the great cataract, or Salto da Cajuru, ten yards in height, to avoid which, the canoes are hauled through a narrow channel here formed by the river. At a distance equal to the preceding is the Cajuru-mirim, and immediately after is found the fall of Da Ilha, the thirty-third and last on this river. Six leagues below this fall, the Rio Pardo receives on its north side the

river Orelha da Anta*; and four leagues lower down, on the same side, the Orelha da Onça*, from the mouth of which, after eleven leagues of navigation, is found the junction which the river Anhandery-uassu makes from the south with the Pardo, which, from the passage of Camapuão to this point, completes a south-east course of forty-five leagues in extent. The Anhandery and the Pardo, from their confluence, run sixteen leagues of navigation westward, in one channel, and disembogue in the west bank of the Parana in lat. about 21°. The velocity of the current of the Rio Pardo is very irregular: it may be navigated downward in five or six days, but cannot be ascended in less than twenty or thirty, and that by hauling, for the force of the stream in some places is too great for oars.

The river Parana is of great breadth and weight of water, and is navigated against its current up to the mouth of the Tieté. In the first three leagues occurs the island of Manuel Homem. Five leagues above this island the Rio Verde falls into the Parana, by a mouth of forty-two fathoms, on its western bank, and at an equal distance above, on the opposite eastern side, the river Aguapehy enters, by a mouth apparently above twenty yards wide. Eight leagues above this river, and on the west side of the Parana, the large river Sucuriu has its mouth, at least fifty fathoms wide, and, after four leagues of navigation further, on the same side of the Parana, is found the mouth of the large and interesting river, the Tieté†. The distance between the rivers Tieté and Pardo, according to the windings of the Parana, may be estimated at thirty-five leagues; the di-

* So called, because they abound with those animals.

† This river being the grand channel of communication from Rio de Janeiro, Santos, St. Paul's, and other places, to the interesting districts of Cuiaba, Matto Grosso, the whole of Paraguay, the river Plata, Potosi, Chiquisaca, and a great part of Peru, I have preserved the particular detail given in this paper, of its numerous falls, and the difficulties of its navigation, as it is now well known, and there is great reason to suppose, that it will soon be much more frequented.

rection north, inclining to the east. Passing up the Tieté, in the first three leagues is found the great Salto de Itapura (a great cascade), to avoid which, the canoes are dragged sixty fathoms over-land. A league above is the difficult fall of Itapura-mirim; another league upwards are the three falls, called Tres Irmaos, and little more than that distance onward, that of Itupiru, half a league long; two leagues further is the fall of U-aicurituba-mirim, and in the upper part of it the small river Sucury enters the Tieté upon its north bank. One league above it is the fall of Utupiba, a quarter of a league in length. The same distance above is the fall of Araracangua-uassu, which is passed with unloaded canoes. Five leagues above this is found the Araracangua-mirim; one league further, the Arassatuba, and at the same distance, the U-aicurituba, from which, in the space of nine leagues, occur seven falls. Three and a half leagues above the last of them is that of the Escaramunca, so called from the abrupt windings of the river among a thousand rocks and stoppages. Two leagues above this is the large fall of Avandava, where the canoes are unloaded, and their cargoes carried half a mile over-land*, and the canoes hauled the greatest part of the way, to avoid a cataract sixteen yards perpendicular. A league and a half above this is the fall of Avandava-mirim, and very near it, that of the Campo, from which there are fourteen leagues of clear navigation to those of the Camboyu-voca, and next to the Tambau-mirim and Uassu, both within the compass of two leagues. One league further is the fall of Tambitiririca; three leagues from thence, the U-amicanga, and a little more than two leagues upwards, the Jacuripipira enters the Tieté on the north side, and has a mouth fifteen fathoms broad. A

* The labour of dragging the canoes over-land to avoid the cataracts might be much lessened (where the finest timber is in such abundance), if Government were to order rail-ways to be made, upon which loaded canoes might easily be drawn on wheels. This would more facilitate the intercourse than any other measure, and, from the present enterprising spirit and wisdom of the Prince Regent's ministers, we may soon hope to see it put in practice.

league and a half above this is the Jacuripira-mirim, six leagues from whence is the fall of Congouha, a league in length. For the space of eight leagues from this there are six falls, of which the last is Banharem. From this it is three leagues and a half to the mouth of the Paraniaba, thirty eight fathoms broad: it enters the Tieté on the north; and the latter river from this point immediately narrows itself to forty fathoms wide. From the mouth of the Paraniaba there is a navigation of four leagues to the small fall of Ilha, and fourteen leagues more, with frequent windings to that of Itahy, near a populous village, called Jundahy. Six leagues from this is the fall of Pedrenegoa, which is a quarter of a league long; and half a league above it, the river Sorecaba, which comes from the town of the same name, in lat. $23^{\circ} 31'$, empties itself on the south into the Tieté. Near this town are several mountains, called Guaraceaba, some of which abound with rich oxide of iron, which, on smelting, has proved very good. Upon them grows fine timber for machinery, and wood of every size, fit for reducing into carbon. Numerous streams flow from them, which may be employed to great advantage, and their base is washed by the river Campanhes, near the Capivara, both of which empty themselves into the Tieté at a short distance. From the river Sorecaba it is only six leagues to Porto Felix, where all the embarkation is now made to Matto Grosso from St. Paul's, the distance being about twenty-three leagues from that city. Through this conveyance, salt, iron, ammunition, clothing for the troops, &c. are sent annually by Government. Trading parties frequently arrive at St. Paul's from Cuiaba in the month of February, and return in April or May.

Resuming our account of the Paraguay, it is to be observed that the Embotetieu enters that river five leagues below the mouth of the Taquari, and on the same side. It is now called Mondego, and was formerly navigated by the traders from St. Paul's, who entered by the Anhandery-uassu, the south branch of the Pardo. On the north bank of the Mondego, twenty leagues above its mouth, the Spaniards

founded the city of Xerez, which the Paulistas destroyed. Ten leagues above this place, in the mountains that form the upper part of the Embotetieu, there is a tradition that there are rich mines which were discovered fifty years ago. One league below the mouth of the Mondego there are two high insulated mounts fronting each other on the Paraguay : at the extremity of the southern declivity of the mount on the west side, near the bank of the river, is the garrison of New Coimbra, founded in 1775 ; it is the last and southernmost Portuguese establishment on the great Paraguay. Eleven leagues to the south of Coimbra, on the west side of the Paraguay, is the mouth of Bahia Negra, a large sheet of water of six leagues in extent, being five leagues long from north to south : it receives the waters of the wide-flooded plains and lands to the south and west of the mountains of Albuquerque. At this bay the Portuguese possessions on both banks of the Paraguay terminate. From thence the river continues to lat. 21° , where, on its west bank, is situated a hill known to the Portuguese by the name of Miguel José, crowned with a Spanish fort with four pieces of artillery, called Bourbon. Three leagues above this the little river Guirino falls into the Paraguay on the east side. Nine leagues to the south of the above fort, and in lat. $21^{\circ} 22'$, are other mountains on both sides the Paraguay, which command this river ; for the eastern side is surmounted with a lofty chain extending to the interior of the country, near which is the sugar-loaf mount ; the opposite side is equally mountainous, but not so high or extensive ; and in the middle of the river there is a high rocky island, which, with the mountainous banks on each side, forms two channels of about a musket-shot across. This, in case of war between the neighbouring nations, would be a post of the highest importance, as it forms a natural barrier, which would require little fortification to render it an effectual obstacle to invasion. Here terminate those extensive inundations, to which both banks of the Paraguay are subject : they commence at the mouth of the Jauru, and to this point cover an extent of 100 leagues from

north to south, and forty in breadth, at their highest floods, forming an apparent lake, which geographers of former days, as well as some moderns, have termed the Xarayas. This inundation confounds the channel of the great Paraguay with those of its various confluent, in such a manner that, from twenty to thirty leagues above their regular mouths, it is possible, in time of the floods, to navigate across from one to the other, always in deep water, without ever seeing or approaching the banks of the Paraguay. During this wonderful inundation, the high mountains and elevated land which it incloses appear like so many superb islands, and the lower grounds form a labyrinth of lakes, bays, and pools, many of which remain after the floods have subsided. From the intricacy of these inundated plains, the navigation is rendered impracticable to all who do not unite experience with skill. From this position, (the only barrier on the Paraguay,) the banks downward are in general high and firm, particularly the eastern or Portuguese side. In lat. $22^{\circ} 5'$, a considerable river empties itself into it, which the Spaniards, at the demarcation in 1753, would have to be the Corrientes, whereas the heads of this river are twenty leagues north of the real Corrientes mentioned in the treaty.

Between the Paraguay and the Parana there runs from north to south an extensive chain of mountains, which have the appellation of Amanbay; they terminate to the south of the river Iguatimy, forming a ridge running east and west, called Maracayer. From these mountains spring all the rivers which, from the Taquari southward, enter the Paraguay, and from the same chain, also, proceed many other rivers, which, taking a contrary direction, flow into the Parana, one of them, and the most southerly, being the Igoatimy, which has its mouth in lat. $23^{\circ} 47'$, a little above the seven falls, or the wonderful cataract of the Parana. This cataract is a most sublime spectacle, being distinguished to the eye of the spectator from below by the appearance of six rainbows, and emitting from its fall a constant cloud of vapours, which impregnates the air to a great

distance. On the north side of the Igoatimy, twenty leagues from its mouth, the Portugueze had formerly the fortress of Bauris, which was abandoned in 1777. The Igoatimy has its sources ten leagues above this place, among high and rugged mountains. The river Xexuy enters the Paraguay on the east side in lat. $24^{\circ} 11'$, twenty leagues below the Ipane, another small river, called the Ipane-mirim, intervening.

This is a summary description of Portugueze Paraguay, to the point where the territory ought (as our Tourist observes) to extend ; and such is the situation of this great river, that the above-mentioned rivers which concentrate toward the interior of Brazil enter it on the eastern side ; not one enters it on the western, from the Jauru to the parallel of the Ipane. Many parts of the banks of all those rivers are laid under water at the time of the floods, and the plains are covered to a considerable depth.

A river of such vast size as the Paraguay, in a temperate and salubrious climate, abounding with fish, bordered by extensive plains and high mountains, intersected by so many rivers, bays, lakes, and forests, must naturally have drawn many of the Indian nations to inhabit its banks : but, immediately after the discovery of the new continent, the incursions of the Paulistas and Spaniards seem to have dispersed and destroyed the numerous tribes : the Jesuits transplanted many thousands to their settlements on the Uraguay and Parana. Other nations fled from the avarice of the new settlers to countries less favoured, but more secure by reason of their distance, and the difficulty of approach. This emigration of one nation to districts occupied by another, became the fruitful source of inveterate and sanguinary wars among them, which tended to reduce their numbers. There are, however, still some Indians left on the borders of the Paraguay, among whom the Guaycurus, or Cavalier Indians, are principally distinguished for valour. They occupy the lands from the river Taquari, extending southwards, along all the rivers that enter the Paraguay on the eastern side, as far as the river Ipane, and in

like manner, on the opposite bank, from the mountains of Albuquerque downwards. They have made war repeatedly on the Spaniards and Portuguese, without ever being subdued. They are armed with lances of extraordinary length, bows, arrows, &c. They make long incursions on horseback into the neighbouring territories; they procure horses in exchange for stout cotton cloaks, called Ponchos, which they manufacture. There are other Indian nations inhabiting these large tracts, some of whom have intermixed both with the Portuguese and Spaniards, there being few of the latter on any part of the confines without some traces of Indian physiognomy.

From the river Xexuy, downwards, the Paraguay takes its general course southwards for thirty-two leagues to the city of Assumpcion, the capital of Paraguay, and the residence of its governor. This city is situated on an obtuse angle made by the eastern bank of the river; the population is by no means trifling, and there are some Portuguese among the inhabitants. The government is of vast extent, and its total population is said to amount to near 120,000 souls. The land is fertile, and contains many rich farms: its principal product is the *matté*, which is exported to Tucuman and Buenos Ayres, from whence it is sent to various parts of the Spanish dominions, along the coast of Chili and Peru, being a general article of consumption among all ranks of people. Its other products are hides, tobacco, and sugar. From Buenos Ayres large boats arrive at the city of Assumpcion, after two or three months' passage; the only difficulty in navigating is the great weight of the waters of the Paraguay, which flow with great rapidity: but this disadvantage is lessened by favourable winds, which blow the greater part of the year from the south.

Six leagues below Assumpcion, on the western side of the Paraguay, the river Pilcomayo enters that river by its first mouth; its second is fourteen or sixteen leagues lower. In this space some other smaller rivers enter on the eastern side, and amongst them the Tibiquari, on an arm of which, twenty leagues south-east from As-

sumpcion, is Villa Rica, a large Spanish town, with much property in cattle on its extensive plains. The river Vermelho enters the west side of the Paraguay in lat. $26^{\circ} 50'$: on a remote upper branch of this river is the town of Salto, near an accessible fall; it is an important point to the Spaniards, who are transporting their goods from Buenos Ayres, Tucuman, &c. to Upper Peru.

The River Parana,

or Great River, which the first discoverers considered as the chief, on account of its abundant waters, unites with the eastern side of the Paraguay in lat. $27^{\circ} 25'$, and their united streams take the name of the Rio de la Plata, which originated in the following circumstance:—Martim de Sousa, the first donatary of the capitania of St. Vicente, furnished Alexo Garcia with an adequate escort to explore the hitherto untrodden wilds to the west of the extensive coast of Brazil. This intrepid Portugueze, by the route of the Tieté, reached the Paraguay, which he crossed, and penetrated considerably into the interior, from whence he returned, it is said, loaded with silver, and some gold: but he halted on the Paraguay, and waited for the coming of his son, a youth of tender years, with some of his people, whilst he sent forward an account of the discovery. He was surprised by a body of Indians, who killed him, took his son prisoner, and carried off all his riches: the year following, sixty Portugueze, who were sent in search of Garcia, shared the same fate. The Spaniards who first settled on this river, seeing so much silver amongst these Indians, and supposing it to be the produce of the country, called the river La Plata.

The Parana derives its principal sources from the west side of the mountains of Mantiqueira, twenty-five leagues west of the town of Paraty.

CHAP. XIX.

Account of the Capitania of Rio Grande.

THE capitania of Rio Grande is one of the most important in Brazil. It is of considerable extent, and is bounded by the capitania of St. Paul's on the north, Matto Grosso on the west, and and by the Spanish territories, between it and the Rio de la Plata, on the south.

Its port is situated about 32° south ; it is dangerous to enter, first from its being shoal water, and next, from a violent sea always running, and from the shifting of the sands. Notwithstanding these inconveniences, there is a great trade carried on from this place to all the ports of Brazil, in brigs and small vessels that do not draw above ten feet water. After passing the bar, which is long, they enter into an inland sea, or lagoon, of deep water, and navigate to the north and west to its head, where the principal river runs into it. To the southward is the lagoon Meni, and the neutral ground, a little to the southward of which is the Spanish fortress of Santa Teresa, lately put in repair.

The principal town is defended by many forts, some of which are upon islets. Since it was taken from the Spaniards by General Coimbra, the Portugueze have much strengthened it, and now there is a very considerable force of cavalry, horse-artillery, and foot-soldiers ; so that at a short notice, with the addition of the militia, a body of five or seven thousand men might be calculated upon.

The climate is considered very fine, and the soil so productive, that this district may be called the granary of Brazil : the wheat grown

here is shipped to all the ports on the coast where bread is used. Farming, however, is carried on in so slovenly a manner, that the grain is always rough, bad skinned, and extremely foul. It is packed in raw hides, which are sewed up like sacks : it swells, and heats frequently on the passage from Rio Grande to the more northerly ports ; and often, after landing in Rio de Janeiro, it is left on the quay exposed for days to the rain.

The vicinity of Rio Grande is extremely populous ; in a circuit of twenty leagues, the inhabitants, including the troops, are estimated at 100,000. Their principal occupations are, the breeding of cattle, for which the immense tract of pasture-land is so well calculated ; the drying and preparing of hides, and the making of *charque*, or what is called, in the river Plata, jug-beef. It is prepared in the following manner :— After the ox is skinned, the flesh is stripped from the bones in as large flakes as possible, in some degree resembling sides of bacon : it is put into hot brine, where it remains from twelve to forty hours, according to the thickness. It is then taken out, drained, and dried in the sun, afterwards made up into packages that weigh about 150lbs., and shipped from this port to all parts of Brazil. It is a general article of consumption among the lower classes and negroes, and is not unfrequently seen at respectable tables, being in taste somewhat similar to hung beef. It constitutes the general food for the sailors, and forms part of almost every cargo sent out from this port. It has found its way to the West Indies, where it is in great request, and has been frequently sold, during the war, at nine-pence or a shilling per pound. The *charque* prepared at Rio Grande is much superior to that brought from the river Plata. During the time that the English troops were in possession of Monte Video, in consequence of an apprehension that the cattle might be driven away, and they be in want of supplies, large quantities were contracted for at St. Pedro, which arrived at Monte Video, though not wanted. They were afterwards shipped for the West India market.

The quantity of hides exported from hence is almost incredible : they furnish many vessels with entire cargoes, which are carried to the northern ports, and from thence embarked for Europe. The annual average may be estimated at not less than three hundred thousand.

Tallow forms another considerable article of commerce, which in general is shipped in the crude state, and not refined, as in the river Plata. The greater part is consumed in Brazil, and the dealers find it preferable to refine the article on the spot, where they manufacture it into candles. It is packed in waste raw-hide packages*.

Horns and horse-hair form an inferior branch of the commerce, and are shipped from this port in great quantities.

The above are the staple productions of Rio Grande, which give employment to perhaps a hundred sail of coasters, some of which make two or three voyages in a year, carrying thither rum, sugar, tobacco, cotton, rice, mandioca, sweet-meats, &c.†

Of European merchandise, they bring wine, oil, olives, glass, and a great variety of English commodities, particularly iron, (though they much prefer the Swedish,) baizes, coatings, stout woollen cloths, Manchester velverets of various qualities and colours, printed cottons, calicoes, muslins, handkerchiefs, silk, cotton, and worsted hosiery, hats, flannels, &c.

Sail-cloth, cordage, anchors, tar, paints, fowling-pieces, ammunition of all sorts, hardware of every description, particularly slaughter-knives, some plated ware, and fancy articles. A great part of

* Some English settlers, disappointed in the river Plata, went to Rio Grande to establish concerns for curing beef, refining tallow, &c., which they soon found it necessary to abandon.

† Almost every vessel brings a greater or smaller number of negroes, it being the practice at Rio de Janeiro to ship off all those who are ill-disposed and troublesome for Rio Grande, whence, if they continue refractory, they are frequently sold into the neighbouring colony.

the goods are conveyed upon horses into the interior, where they are carried from house to house for sale or exchange.

During the old system, so lately as within these four years, a most lucrative trade was here carried on with the Spaniards, who came in numbers, and most eagerly bought up the tobacco, and such of the English manufactures as could be transported on horse-back, at great prices. Thus Rio Grande and its vicinity became very en-vious situations, where considerable fortunes were made in a little time, as the goods bought were much in request, though contraband, and were paid for in specie. This trade, so advantageous to each party, is now entirely ruined through the eagerness of our speculators in over-stocking the markets, and selling for two what would have been eagerly bought for six.

The neighbourhood of the capital is an unpleasant place, being surrounded with sand and sand-hills of no inconsiderable size, formed by the wind blowing the sand in heaps in various directions, which become half indurated, and appear stratified. The excessively high winds which frequently prevail blow the sand so as to be very disagreeable, as it enters every part of the house.

The cattle bred in this capitania are very numerous, and large herds are brought hither from the Spanish frontiers.

The large river Uruguay rises in this capitania, and empties itself into the river Plata, a little above Buenos Ayres: there are numerous others of less consequence, the banks of which are well stored with wood. Some attempts were lately made, by miners sent from Villa Rica, to work gold-washings. In the neighbourhood of the capital they have coal, a specimen of which I have seen. From the same district, a gentleman shewed me a substance which he could not define; on seeing it, I asked him if he was certain that it came from thence; he assured me that he was: I then told him it was wolfram; and stated that this metal strongly indicated tin, of which it is frequently an attendant in Europe, though probably it may not be so in America or Asia. It was amorphous, not rounded

by friction, and weighed at least a pound. Of the geology of this capitania very little is known.

In various parts jaguars, and other beasts of prey, are very common. Among the granivorous animals are capivaras of great size, deer in great numbers, and armadillos, which afford excellent eating when roasted. Of birds, there are ostriches of the dark-coloured species, which go about in flocks in great numbers. There are eagles, hawks, and other birds of prey, particularly a species of crow of the vulture kind. Cranes, storks, wild turkeys, ducks, partridges, horned plovers, goat-suckers, horned owls, small parrots, cardinals, humming birds, &c. are found in great numbers.

The inhabitants are, generally speaking, athletic and robust, and so extremely fond of riding, as not to go the smallest distance on foot. They are esteemed excellent horsemen, and greatly surpass their neighbours in dexterity and agility, particularly in catching cattle with the balls and the lazo. But it ought to be understood that the Spaniards have Peons on their farms, who are more nearly allied to the Indians than to them, whereas the Portuguese have Creolians, bred up to the business, or expert negroes, who are inferior to none in this labour.

It is singular to Europeans, that in this fine climate, where the thermometer is frequently below 40° Fahrenheit, and where are bred as fine cows as any in the world, and every convenience is at hand for dairies, neither butter nor cheese is made, except on particular occasions; nor is milk even for coffee to be procured at all times. It may probably be urged that the production of these articles would not answer the purpose of the farmers: but certainly it might be made to do so; and I hesitate not to say, that a hundred cows, kept for dairy purposes, would yield to any man capable of rearing, training, and managing them, a greater profit than any other part of husbandry. This colony might easily be made to supply the neighbouring districts, and even the whole of Brazil, with these articles.

A number of years ago some hemp was grown here by order of Government: it proved excellent, but was abandoned because it was troublesome to dress, and probably did not yield sufficient profit.

In some places grapes are very good, and probably wine will soon be made from them, as the restraint laid by the mother-country upon her colonies is now removed.

For the last two or three years, troops have been continually sent to Rio Grande, where they soon become disciplined, and are ready for any expedition, should hostilities commence with their neighbours. Perhaps in no place could an army be maintained at less expence; their cavalry stands in the highest reputation, and their flying-artillery is said to be equal to any in Europe; nor is this improbable, when we consider the excellence of their horses, and the discipline the troops have undergone ever since they left St. Paul's.

CHAP. XX.

General Observations on the Trade from England to Brazil.

HAVING, in a preceding part of this work, stated the importance of Rio de Janeiro as a port which, from its locality, appears destined by nature to become the metropolis of a vast empire, and the centre of an extensive commerce, it may not be improper in this place to treat more at large on this interesting subject.

The ships best calculated for trade from England are those which carry about four hundred tons, and sail well: it is particularly necessary that they should have the latter quality; for, if they have not, the voyage from thence to England is frequently rendered very tedious by their being driven so far to the westward by the north-east trade-wind. Owing to this circumstance, it is not uncommon for a packet, or fast-sailing ship, to make a passage from the coast of Brazil to England in five or six weeks, when a heavy-sailing vessel is double that time in arriving at her destination. The best season for sailing from England, and that which affords the greatest probability of making a short passage, is the month of February or March, because then the north-east winds prevail. I should advise crossing the line in not less than 22° , nor more than 25° west longitude, if the destination be the Plata or Rio de Janeiro, as I have twice experienced very heavy calms in crossing the line between 19° and 20° . Ships bound to Bahia, Pernambuco, and ports more northerly, will of course cross the line more to the westward, as they will have nothing to fear; but the south-west trade-wind would generally cause ships going farther south to fall in with the land too soon. Should that be the case, I would advise them, if they make the land

to the north of the Alboroxos*, to keep in-shore, as the land-breeze frequently blows along-shore until mid-day. The ports on this coast are in general good and secure, nevertheless it is highly desirable to be provided with good anchors and cables, particularly in the Rio de la Plata. In the Portugueze territories the port-charges are not so expensive as formerly ; a dollar per day is exacted for anchorage, which forms the principal charge. I particularly recommend that all homeward-bound ships should lay in a sufficiency of necessary stores, especially of water, so as to make the passage without being obliged to go into the Western Isles, as there the port-charges and attendant expences are very exorbitant, though the only articles wanted are a few casks of water, and a hundred weight or two of bread.

For loading vessels, peculiar boats, so frequently used in the West Indies, are by no means wanted in these ports, though good boats are always absolutely necessary. Ships are loaded in Rio de Janeiro, and other ports of Brazil, as well as in the Plata, by lighters, which are very expensive, and difficult to be procured when many ships are loading.

When a vessel enters any of the ports, the health-boat and custom-boat make a visit before she anchors, and their report is immediately made ; after which, proper officers, called guards, are sent on board. These men in general are not very liberally provided for ; they are extremely civil and accommodating, and ought to be treated with respect. Since the establishment of the treaty of commerce between this government and that of Brazil, the contraband trade has been almost done away ; for the duties are now much reduced, and the accommodation which the judge and subordinate officers of the cus-

* It has been found, however, from modern surveys, that those rocks are by no means so dangerous as they have been represented.

tom-house are disposed to allow is such, as to render that nefarious practice unnecessary.

It may not be improper in this place to describe the consequences produced in Rio de Janeiro by the excessive commercial speculations into which our merchants entered, immediately after the emigration of the Court of Portugal, and which could only be equalled by those which followed our expeditions to the Rio de la Plata.

Owing to the incredible competition or struggle among our merchants, who should send most ships and cargoes to a country, whose civilized population, exclusive of slaves, does not exceed eight hundred thousand souls, (one-third, at least, of whom may be said to make use only of what their land produces,) it is natural to suppose that the market would be almost instantly overstocked. So great and so unexpected was the influx of English manufactures into Rio de Janeiro, within a few days after the arrival of the Prince, that the rent of houses to put them into became enormously dear. The bay was covered with ships, and the custom-house soon overflowed with goods: even salt, casks of ironmongery, and nails, salt-fish, hogsheads of cheese, hats, together with an immense quantity of crates and hogsheads of earthen and glass ware, cordage, bottled and barrelled porter, paints, gums, resin, tar, &c. were exposed, not only to the sun and rain, but to general depredation. The inhabitants of Rio de Janeiro, and more particularly some of the Creolians and strangers from the interior, thought that these goods were placed there for their benefit, and extolled the goodness and generosity of the English, who strewed the beach to a great extent with articles for which their own countrymen had heretofore charged them such high prices. It is true that the gentlemen entrusted with these valuable consignments did apply for centinels to be placed to guard the articles thus exposed, and their request was immediately complied with. The result was such as might easily have been anticipated from such watchmen, many of whom did not fail to profit largely by the appointment. In the course of several weeks the

beach began to assume a less crowded appearance ; some few of the goods were taken to the residence of their owners, others were removed ; but to what place, or by whom, there was no way of ascertaining ; and a very great proportion was sold at the custom-house *for the benefit of the underwriters*. This stratagem, so frequently practised, (and certainly deserving of the severest reprehension,) afterwards operated as a very serious injury to the regular sale of articles ; for, as the market was so overstocked, scarcely any one would offer money for goods, except at the custom-house sales. As the depreciation continued, numberless packages were there exposed for sale, in part damaged, or apparently so. Indeed, little more than the mark of a cord on the outside of a single article, or a corner discoloured, in a package however large, was a sufficient pretext for presuming and pronouncing the whole to be damaged. By means of this sentence, so easily obtained, great quantities of goods were brought to the hammer in the custom-house warehouses, under every disadvantage ; thus the owners recovered the amount insured for, and the insurers lost the difference between that sum and the price they were sold at, also the attendant expences. Many of the underwriters will, no doubt, retain a lasting remembrance of the sales which took place at Rio de Janeiro, and other parts of South America, *for their benefit*.

To the serious losses thus occasioned by an overstocked market, and by the sacrifice of goods at whatever price could be obtained, may be added another, which originated in the ignorance of many persons who sent out articles to a considerable amount not at all suited to the country ; one speculator, of wonderful foresight, sent large invoices of stays for ladies, who never heard of such armour ; another sent skates, for the use of a people who are totally uninformed that water can become ice ; a third sent out a considerable assortment of the most elegant coffin-furniture, not knowing that coffins are never used by the Brazilians, or in the Plata. To these absurd speculations may be added numerous others, particularly in

articles of taste : elegant services of cut glass were little appreciated by men accustomed to drink out of a horn or a cocoa-nut-shell ; and brilliant chandeliers were still less valued in a country where only lamps that afforded a gloomy light were used. Superfine woollen cloths were equally ill-suited to the market ; no one thought them sufficiently strong. An immense quantity of high-priced saddles, and thousands of whips*, were sent out to a people as incapable of adopting them as they were of knowing their convenience. They were astonished to see Englishmen ride on such saddles ; nor could they imagine any thing more insecure. Of the bridles scarcely any use could be made, as the bit was not calculated to keep the horse or mule in subordination : these articles were of course sacrificed. Great quantities of the nails and ironmongery were useless, as they were not calculated for the general purposes of the people. Large cargoes of Manchester goods were sent ; and, in a few months, more arrived than had been consumed in the course of twenty years preceding. No discrimination was used in the assortment of these articles, with respect either to quality or fineness, so that common prints were disposed of at less than a shilling a yard, and frequently in barter. Fish from Newfoundland met with a similar fate ; also porter, large quantities of which, in barrels, arrived among a people, of whom a few only had tasted that article as a luxury. How the shippers in London, and other British ports, could imagine that porter would at once become a general beverage, it is difficult to conceive, especially when sent in barrels. These cargoes, being unsaleable, were of course warehoused, and of course spoiled. Newfoundland fish, that was generally sold at from twelve to twenty dollars per quintal, was now unsaleable at four, and in many instances did not pay warehouse-room. Earthenware was perhaps rather more favourably received than many of the former articles, for plates, &c.

* In Brazil the bridle is made of sufficient length to serve the purpose of a whip.

soon came into general use. Having enumerated various commodities which suffered a general depreciation, it may be sufficient to add that many invoices of fancy goods, and such as do not constitute a staple trade, were sold at from sixty to seventy per cent. under costs and charges, and others were totally lost. To enter more into detail would be unnecessary : it is hoped that the trade will in time find its regular course, and that the adventurers will derive from it some compensation for their former losses, though no possible change can repair the total ruin which numbers have incurred. Experience will now have fully shewn the fallacy of those golden hopes which some persons conceived from the reputed wealth of South America, and we shall no longer hear of those absurdities which characterised the first commercial speculations to the river Plata. What must have been the delusions of those traders who sent out tools, formed with a hatchet on one side and a hammer on the other, for the convenience of breaking the rocks, and cutting the precious metals from them, as if they imagined that a man had only to go into the mountains, and cut as much gold as would pay for the articles he wanted !

Other evils resulted from these ill-judged and excessive speculations to South America, which might naturally have been anticipated. The first was, that the produce was bought up with such avidity that many articles were soon double their ordinary value, and continued to rise as our manufactures lowered. But this was not all : the purchasers suffered equally from their ignorance of the quality of the articles, as from their eagerness in purchasing them. For instance ; any kind of sebaceous matter was greedily bought for tallow ; and numberless hides, spoiled in the drying and eaten by the grub, met with ready sale. Little attention was paid to the state they were in ; and thus it frequently happened that lots and cargoes of those articles, instead of reimbursing the adventurer to whom they were consigned, scarcely paid freight and charges. This was also the case with coffee and other staple articles. Many gentlemen, more knowing than others, sent home lots of curious wood, and even en-

tered into the illicit trade of shipping the dye-wood, which generally proved very disadvantageous, as the wood of that species grown in the vicinity of Rio de Janeiro is very inferior in quality to that of Pernambuco, from whence that trade is allowed by contract. The folly of speculation did not stop here: precious stones appeared to offer the most abundant source of riches; the general calculation was made upon the price at which they sold in London: but every trader bought them, more or less, at the price at which they were offered; invoices of goods were bartered for some, which in London would sell for, comparatively, a trifle, as they were taken without discrimination as to quality or perfection; tourmalines were sold for emeralds, crystals for topazes, and both common stones and vitreous paste have been bought as diamonds to a considerable amount. Both gold and diamonds were well known to be produced in Brazil; and their being by law contraband, was a sufficient temptation to eager speculators who had never before seen either in their native state. False diamonds were weighed with scrupulousness, and bought with avidity, to sell by the rules stated by Jefferies. Gold-dust, as it is commonly called, appeared in no inconsiderable quantity, and, after being weighed with equal exactness, was bought or bartered for. But previous to this many samples underwent the following easy and ingenious process:—The brass pans purchased of the English were filed, and mixed with the gold in the proportion of from five to ten per cent., according to the opinion which the seller formed of the sagacity of the person with whom he had to deal: and thus, by a simple contrivance, some of our countrymen repurchased at three or four guineas per ounce the very article which they had before sold at 2s. 6d. per pound.

In enumerating the losses occasioned by the depreciation of goods, I have omitted to notice the heavy expences upon them after the purchase, as packing, shipping, convoy-duty, freight, insurance, commission, and other incidental charges. Then suppose any staple article to be bought; there are the expences of commission for

buying, of warehouse-room, shipping and the attendant fees, freight, and insurance; and, on the arrival of the merchandize in England, there are duties, dockage, warehouse-room, and many other items which leave no small interest in the hands of those who do the business.

It is scarcely possible to imagine, much less to describe, the disappointment which prevailed among mercantile gentlemen a few months after their arrival in South America, particularly among those who had orders not to sell the goods entrusted to them lower than the prices specified.

Their sanguine expectations of incalculable heaps or bars of gold speedily vanished; many persons came to look at their stores, but few offered to buy; and, incredible as it may appear, yet it is true, that when goods were offered to them at half the original cost, they invariably exclaimed, "Very dear." Scenes of this kind I have repeatedly witnessed, and could scarcely suppress my indignation at seeing goods thus depreciated, which a few months before were so eagerly sought after. Gentlemen consignees so situated were at a loss how to act: the duties, rents, charges, and other expences were high, and must peremptorily be paid; their only resource was to open a shop or room for the purpose of selling their goods by retail.

These gentlemen had calculated upon doing business only in the large way, similar to our first mercantile houses: they had set apart their hours for horse-exercise, and for going to their country-seats*. The idea of vending by retail was a bitter which destroyed all their pleasing anticipations of doing business in style: they came out as merchants, and could not stoop to be shopkeepers; and many of them, rather than yield to that degradation, sent goods to auctions,

* Delicate connections were soon formed, and females of the obscurest class appeared dressed in the most costly extreme of English fashion.

Others with more prudence accommodated themselves to circumstances, and were not offended at being asked for a pair of boots or a hat. These persons reaped all the advantage of the trade, as they got their price by selling to those whose necessities prompted them to purchase, and were ever ready to sell by the package when opportunity offered. Many of these gentlemen, it is true, have been much blamed by the consignors, who have expressed great dissatisfaction at their proceedings, both in the disposal of the property sent to them, and in purchase of merchandise to return; these complaints were, perhaps, in some degree founded in reason, though much may be said in extenuation of the former, not only on the ground of their want of experience, but the unexampled situation of affairs; for a respectable and confidential clerk, however capable of copying an invoice, going to Lloyd's, or casting up a page in a ledger, must make a very poor figure as a tradesman, being very incapable of ascertaining or stating the merits of manufactured goods, and still less qualified to purchase the staple articles and general produce of the country. These severe and grievous disadvantages frequently gave the Brazilians the double advantage of buying below the market-price, and of selling above it.

From these and many other unfortunate and disastrous circumstances, the trade could not fail to become gradually worse and worse; hence it is very natural to imagine that necessitous consignors, eager to see the gold which they had so long and so vainly anticipated, became pressing for remittances. One disappointment succeeded another; remonstrances were made; and powers of attorney were at length sent out almost by cargoes; property was removed from one consignee to another, at great expence, but to no purpose. At home the greatest confusion prevailed for want of money, until that lamentable and unfortunate epoch, when the columns of the Gazette were filled with the names of those very respectable merchants, who, before those ruinous speculations, were in a state of affluence.

Misunderstandings frequently arose between the English and the Portuguese, either in making contracts, or in not complying with them; and they were continually prosecuting each other for injuries which both parties professed to have sustained. These litigations might have terminated very expensively, if not otherwise seriously, had not the wise measures of the Judge Conservador, approved by His Excellency Lord Strangford, prevented the perplexities of legal proceedings. The appeals of the English were always heard; they were strangers whom His Royal Highness protected, and they ever found in the Condé de Linhares a firm and powerful friend, and in the British Ambassador a wise and prudent supporter of their claims. They were allowed peculiar privileges, similar to those enjoyed by the nobles in Portugal: they could also claim the possession of houses inhabited by useless families; their rents could not be raised; and, in case of embarrassment in their affairs, an appeal to the Prince procured them a term of ten years, during which their creditors could not molest them. These and many other acts of favour toward the English certainly excited the jealousy of the resident Portuguese, who frequently exclaimed, that to live in Brazil it was necessary to become an Englishman.

Had it been possible to bring the whole trade to Brazil under one interest, many of these fatal consequences might have been prevented. It should have been under the control and direction of experienced merchants, who would have sent out such articles as were known to be wanted, and whose agents would have been actively employed in obtaining intelligence respecting the population of the country, its produce, and its consumption, particularly in goods of English manufacture. Interest would naturally prompt them to order and buy all that the country required, and return to this country those articles which were most likely to answer the general demand.

If the trade had been properly conducted, we should have received for a fifth of the produce which has been sold the same amount which has been paid for the whole, and it is certain that the pur-

chasers would have been better satisfied; for, to vend goods at a reasonable price is the certain way to keep the demand steady, but to force them upon the consumer, whether he wants them or not, is to render what was once a luxury so common as to become contemptible.

In the Plata, the monied men bought very largely of the cargoes which first arrived, and were afterwards considerable losers by the overflow which took place, when men of less capital bought for ten thousand dollars, what a few weeks before sold for fifteen or twenty. In Rio de Janeiro the case was somewhat different; for the monied men thought the English manufactures inexhaustible, and therefore kept back their gold, leaving the trade principally to men of a secondary class, who bought with great caution, and sold very promptly, for fear of a further depreciation.

Having stated the ruinous consequences of sending out goods not saleable, it may be proper to point out the articles in general consumption, though even these may be sold at great loss if the markets be overstocked, for trade must depend on the wants and necessities of the consumer. If a person possesses seven or eight hats, as many coats, &c. it is unreasonable to suppose that he can want more, though he may be tempted to purchase, if offered at very reduced prices: but even that must have an end, and a trade must soon expire where one party is constantly the loser. This has been too generally the result of our late speculations in South America, into which people hurried without calculation or foresight.

Iron and steel are articles for which there is a general and constant demand. The smiths prefer Swedish iron, as they have been always accustomed to it, and do not know how to heat and work the English. The next article to be mentioned is salt, in which the Brazilians are by no means nice. It is made and loaded at one or two places on the coast, but that which is most esteemed comes from the Cape de Verde islands; that brought from Liverpool is generally used in the sea-ports. Common woollens, baizes, and some stout fine cloths, particularly blue and black, are generally worn; also kersey-

meres. Cotton goods of almost every description, especially if low priced, meet with ready sale. Hats of all sorts, (particularly dress-hats,) and boots and shoes of English manufacture, have of late been sold in great quantities; the leather is much preferable to that made in Brazil. Common and finer earthenware, and glass; some sorts of fine and coarse hard-ware; some plated goods, as candles now begin to be used instead of lamps. Bottled porter, Cheshire cheese, butter, cheap furniture, tin-plate, brass, lead in various shapes, shot of all sizes, gunpowder, drugs, some philosophical instruments, books, low-priced paper, watches, telescopes, salt provisions, as hams, tongues, and barrelled pork, low-priced sadlery, and, most of all, India and other goods fit for the African coast. Marble mortars, mirrors, and many fancy articles of less note. Silk and cotton hosiery, fashionable dresses for ladies, particularly fine stockings and shoes.

It is to be observed that the mother-country still continues to send oil, wine, brandy, linens, cottons, some silks, and a variety of articles of inferior consequence. India goods, consisting chiefly of cottons, are sent from the Malabar coast, and China goods are in great plenty. From North America are imported flour, salt provisions, turpentine, tar, staves, household furniture, &c.

Naval stores, clothing for sailors, arms, &c. may be said to be generally in demand.

The staple articles of trade from Brazil and the river Plate which are most in demand in this country, when its markets are not overstocked, are cotton, coffee, hides, tallow of good quality, horns, hair, furskins, and feathers. Sugar cannot be enumerated among them, because our existing colonial regulations prevent it from being generally used in this country: but Brazil is well calculated for growing it, having every convenience of situation, and all the materials requisite for machinery. To the above may be added some wood; that beautiful species, called jacaranda, here denominated rose-wood, is subject to so high a duty in this country, that it cannot be generally

introduced for cabinet use, that from the East Indies excepted. I do not say any thing of indigo, as it is in general inferior. Rice of excellent quality is cultivated to great extent. Tobacco, it is to be hoped, will be better cured, to suit the English market; for no where can a soil and climate be found more favourable to the production of that plant than in Brazil.

Since the emigration of the court from Lisbon, Rio de Janeiro may be truly called the mart of South America, and is likely to become a general depôt of goods from the four quarters of the globe: yet its commerce to Africa, to India, and the islands in the Indian sea belonging to the crown of Portugal, as well as its intercourse with China, has scarcely been entered into. So many disappointments, caused by the political events in the mother-country, and so unexpected an influx of goods from England, occasioned such a stagnation in commercial dealings, that the opulent merchants were determined not to speculate, and other great capitalists, from the heavy losses they have sustained, were unable. Thus the monopoly that was hitherto exercised by the former class of merchants ceased; the English took their place, and sold goods to the public in the best manner they could. Numbers of public auctions were established, and goods of all descriptions were sent thither to be disposed of in the best way possible, wholesale or retail, in barter, or for money. Thus little was done by private merchants in comparison with what was sold at auctions, which indeed appeared the only possible mode of vending a great variety of goods. Residents in Rio de Janeiro, and persons from the country in great numbers, attended the sales; the general desire was to buy cheap, without any regard to quality. From this source branched numerous smaller streams; for many persons who bought at these sales immediately parcelled out the goods in smaller assortments, and gave employment to walking shopkeepers, who were daily occupied in going from door to door, followed by negroes, bearing on their heads tables-full of various arti-

cles. Thus muslins, handkerchiefs, prints, kerseymeres, hardware, &c. might be purchased cheaper than they were obtained in England.

When trade shall have resumed its regular channel, Rio de Janeiro will, no doubt, be a grand and general market for the produce of all the ancient Portugueze possessions : it will be a kind of half-way house between Europe and India, and every description of Asiatic produce will be found in its warehouses. Brazil, freed from colonial restrictions, will soon become doubly populous ; its gold, instead of being transported to foreign countries as heretofore, will circulate among the inhabitants ; and, under a wise legislature, it is reasonable to hope that in twenty years this great country will rise in prosperity more than any other in the same space of time.

[The text in this block is extremely faint and illegible. It appears to be a multi-paragraph document, possibly a letter or a report, with several lines of text visible across the page. The content is too blurry to transcribe accurately.]

A P P E N D I X.

(A.) Page 44.

THE revolution of the provinces of Rio de la Plata ought not to be considered as a momentary commotion caused by a party, or as a public ferment of but transient duration. It is an unanimous proceeding of all the people, which had been long in preparation, and the execution of which was called for by circumstances — by the dismemberment of the Spanish monarchy, and by the consequent necessity, that America should provide for her own existence, by constituting herself at least in such a form as should shelter her from the ruin that threatened the great whole. To view it in this light, we need only consider the simultaneous commotions which took place in other distinct parts of Spanish America, which, without any previous combination of plans, produced the same general results as in this division of the colonies, and which, notwithstanding the difficulties opposed to them, have lasted two years, not only without abatement, but with an accession of strength, from the very obstacles employed to quell them.

Considered as a political event which threatens to change the aspect of an extensive continent, the revolution of Buenos Ayres well merits the trouble and attention of tracing its causes, its progress, and its effects; nor ought we to act so lightly towards a people, as to censure their conduct, without ascertaining the motives and objects by which it was actuated. As the spirit of party is one of the effects of every revolution, and, as the innovations in America must have had as many enemies as there were individuals united by interest to the ancient form of government, or subsisting on the infamous monopoly by which she has been oppressed for three centuries, it will not appear strange, that the selfish and the narrow-minded should have misrepresented the proceedings of the inhabitants in the out-

set of their new career, and should have attacked with calumnies those men whom they could not reduce to submission by force. Whether or not the revolution of the provinces of the river Plate be just, whether or not it be well meditated, and will in the end be successful, are problems which I am neither able nor willing to solve. Regarding it merely in a historical point of view, I shall proceed to speak of the more recent events, and attempt to give the reader an idea of the state in which those countries are at present, and of the manner in which they have brought about the changes that are now observable among them.

For this purpose, it is necessary to direct our consideration to the period anterior to the establishment of the present Junta of government, and recur to the events which took place among the people, subsequent to the invasion of the English. The military exertions occasioned by that enterprise, awoke the spirit of the inhabitants of the vice-royalty, and excited in them a degree of vigour and energy of which they had never before been conscious. The royal authority exercised by the viceroy, under whose government the country had been lost at the period of Major-General Beresford's expedition, could not but sink into contempt before the eyes of a people who had of themselves re-conquered the country, and had afterwards successfully proved their valour against the English arms. A viceroy incapable, if not pusillanimous, who had done nothing more than passively witness the loss of two important places belonging to the Spanish crown in these territories, and who, by his feeble measures, was bringing on other misfortunes, at the time when Sir Samuel Achmuty had already occupied Monte-Video, was ignominiously deposed by an extraordinary Junta of the people, who assembled in the Cabildo to treat of measures fit to be adopted in circumstances so critical. I shall abstain from giving an opinion on this signal proceeding of the people of Buenos Ayres, which was doubtless no good augury for the interests of the metropolis, and I know not whether, in respect to the illegality of the measure, the colonists ought to have waited for the resolution of the cabinet of Madrid, on a point which, although very urgent, was, in truth, delicate; but certain it is, that had they not, on this occasion, taken to themselves the privileges of the Sovereign, there was much risk that his decisions, when they should arrive, might be dispensed with. This deposal, by a natural consequence, gave the chair of the Viceroy Sobremonte to the naval captain, Don Santiago Liniers, a French emigrant, who had headed the military expedition which restored the place to the Spaniards on the 12th of August 1806, and who occupied the same rank when it was invaded by General Whitelocke in 1807. It may with truth be said, that accident alone effected the elevation of this man; devoid of morals, and a victim of dissipation and gaming,

he was sunk into a humiliating obscurity, whence he rose from the condition of a subaltern to the high rank of chief of these provinces, of which he had just been the restorer and defender, not by the effect of his military talents, but through the favour of fortune alone. Vain of success equally unexpected and glorious, he devoted himself entirely to the most ambitious projects, and finished by uniting himself with the revolution of Spain, which, leaving the monarchy without a head, and dismembering all the parts of that great edifice, presented to him the most favourable field for the execution of the various plans he was continually forming. At one time it appeared to be his intention to keep all these parts of the kingdom inactive, until the fate of the metropolis should be decided, and he might join the victorious dynasty, as was done by his predecessors in the war of the Succession; at another time, he openly favoured the cause of the French, and, as if he distrusted the result of the contest, seemed desirous of precipitating these countries into the power of the Usurper. He even ventured to issue cautionary proclamations of an insidious nature, in which he invoked the name of His Imperial and Royal Majesty, a name hitherto never recognized in these regions, and sent out emissaries with letters for Napoleon, giving an account of the state of the colony, as he had done even in the time of Charles IV., when he addressed to Paris the accounts of the late defeat of the English in the river Plata, suing, by this plausible pretext, the favour of the Regulator of the Destinies of Europe, for such he styled him. Lastly, he was disposed to uphold the pretensions of the Infanta Carlota to the internal government of that territory, by way of a provisional administration, during the uncertain state of the Spanish monarchy. Of all these projects, among which I should be at a loss to distinguish the favourite one, the basis and indispensable condition was, the permanency of his own command in the provinces, which is indeed the end and motive of all the public functionaries of America; and, as it was to be feared, that the disorder in the metropolis might give rise to commotions in the colonies, which are ever to be dreaded by the constituted authorities, the Viceroy Liniers thought proper to conceal the real state of affairs, at least for some time, until he might be able, with greater security, to fix his views on a certain point. Conformably to this safe line of policy, he contradicted all the rumours which had been spread, respecting the disastrous fortunes of the house of Bourbon in Europe, and constantly gave the lie to all the varying accounts concerning them which were received through private channels, so that whoever dared to doubt the sincerity of the French towards Spain, was accused of treason and blasphemy. The magistrates (Oidores) would have entered into the plan, had it been merely for the sake of continuing in their offices; and the Cabildo,

at that time composed of European Spaniards, favoured these artifices without seeing their drift; for, from the remarkable ignorance which notoriously characterized every individual among them, we have not the smallest scruple in impeaching their judgment; but, as a voluntary concession to their sense of honour, we would rather allow, that the sole intention which actuated them, was a rage for suppressing bad news. From these different elements of authority, cunningly combined by Liniers, was formed an extraordinary Junta, (convoked and presided over by himself,) to determine on all public concerns which presented themselves; this establishment, however, was accidental, and produced no other effect than that of giving efficiency to the will of their chief.

The arrival of a French sloop of war at Maldonado in the month of July, of the same year (1807), with an emissary sent by Napoleon, produced a change of scene, and developed the mystery. However, as the vessel had arrived at sixty leagues distance from the capital, the affair was still misrepresented to the people, who were told that, in proof of the good faith with which the French had entered Spain, Napoleon sent this ship, laden with muskets and other arms, in order that they might defend themselves against the English. The Old Spaniards resident in Buenos Ayres were the greatest dupes of this miserable imposture; and for two successive nights exhibited the ridiculous spectacle of parading the streets with bands of music and lighted torches, and rending the air with acclamations of *Viva Napoleon*: so earnest were they in this classic display of their stupid foolishness, that, it may be presumed, they excited the compassion even of those who contrived the deception. The emissary having arrived at the capital, the Junta above-mentioned was convened, and his dispatches were read; they consisted of some orders from the new ministers O'Farrel and Azanza, giving an account of the occurrences at Aranjuez and Bayonne, and the consequent abdications of the crown of Spain in favour of Joseph. In these papers, reflections were made on the necessity of acceding to such measures, even if it were for no other reason than that of avoiding a disastrous war, which could be productive of no advantage, as its last result would be the ruin of the nation, which, in that case, would have to yield unconditionally to the law of the conqueror, whereas an opportunity now offered, of peaceably placing at its head a wise king, supported by the immense influence and power of his omnipotent brother. To this was added, a long and piteous narrative of the evils brought on Spain by the family of the Bourbons, especially by its later branches, whose misconduct, although described in exaggerated terms, and with a malicious design, was not altogether misrepresented; the whole concluded with an admonition to the Americans, stating, that the

well-disposed Spaniards of the metropolis expected that they would conduct themselves in this critical conjuncture, at least, with the prudence which their forefathers had manifested in the war of the Succession. Moreover, there came orders from the council of Castille, requiring that oaths of allegiance should be taken for the new King Joseph, with others for the Emperor Napoleon, and an additional mass of printed papers were distributed on the occasion. As these papers imposed a responsibility on the chiefs of the Viceroyalty for whatever contravention or resistance might take place, and as the affair was of such high importance, the government thought they could free themselves from such responsibility by transferring it to the people, who might, of their own accord, take a resolution for which they themselves wanted courage, and which, being adopted as it were by the force of the general will, would prevent any blame being attributed to the persons in power. The Cabildo were of opinion, that the state of the monarchy should be made public, and that, by burning the papers brought by the emissary, (which was done to the printed ones, but not to the ministerial orders, &c.) an idea of the nature of his commission might go forth, and they might then wait to see what part the people would take, still inclining them to hope for a favourable turn to the existing disasters, which, in their judgment, were but transitory. Liniers executed all this in the most dexterous manner, without closing the way against the introduction of his own plan, and without losing sight for a moment of his attachment to the French. The proclamation he issued, announcing the state of Spain, and the disappearance of the reigning family, will be an eternal monument of his sinister intentions, as well as a source of shame to the people, for having suffered him to insult them by invoking the name of Napoleon in order to influence their conduct.

It is naturally to be supposed, that he would still keep on the best terms with the French officer, whom he treated, in private, with every civility; and in order that he might shelter him from the insults of the multitude, who began to be disgusted at transactions which they could not comprehend, as well as that the real nature of his intentions might not transpire, he persuaded this officer to go to Monte-Video, where he might expect an early opportunity of returning to France, the brig that brought him having been run aground to avoid an English frigate which was in chace of her. In the course of a process afterwards instituted respecting the flight attempted by this individual, an official letter has been published, from Liniers to the Governor of Monte-Video, in which he enjoins that the greatest respect and attention be paid to the person of the emissary, as charged

with matters of the greatest importance to the interests of the nation, and orders that every facility may be afforded him for a speedy return to Europe.

The Governor of Monte-Video, at this period, was Don Xavier Elio, the same man who was there, until lately, under the title of Viceroy, conferred on him by the Junta of Cadiz. He had very powerful motives for disapproving the conduct of the chief, who was now beginning to get into notice. Not a word had been said on the oath of allegiance to Ferdinand VII., and the steps which the Government took were so indirect, that very little penetration was necessary to discover reasons for doubting the sincerity of their intentions. Don Xavier Elio rebelled from the submission due to the authority of the Viceroy, and forming a Junta at Monte-Video, in imitation of several provincial Juntas which were already known to have been constituted in Spain, declared that he would obey no ordinances emanating from the capital of the province, which he considered to be oppressed under the command of a traitorous chief. Thus a pernicious lesson was inconsiderately given, by which the people did not fail to profit; and whatever attempts may be made to exculpate the refractory proceedings of a subaltern governor, who would in no degree have endangered the cause of his nation by acting prudently, and might at all events have adopted measures of moderate precaution, it cannot be denied that this scandalous example of insubordination must have cost dear to its instigators. An expedition of troops was sent by the Viceroy against Monte-Video, and thus, for the first time since the days of Pizarro, a civil war broke out in the Spanish Americas.

Meanwhile, Liniers was extending the scope of his ambitious views, and in proportion as the accusations against him multiplied, he saw the necessity of proceeding more openly in the execution of his plans. His first object was to gain a formidable party in the country who might second his measures, and he began, by raising to the rank of officers, the most abandoned members of society, and others whose want of honour assured him that they would act whatever part he assigned them. The invasions of the English had required an augmentation of the troops, beyond the means of the colonial treasury to maintain; but far from reducing the supplementary force, as might have been expected when the urgency of the occasion which called it forth had subsided, he daily augmented it, by creating new regiments, one of which he distinguished by the name of the *Grenadiers of Liniers*, and reserved it as his body-guard. The administration of justice, which by an absurd provision in the constitution of the colonies is vested in the Viceroys, was subjected entirely to his favourite project;

despotic as have been all the chiefs sent by the court of Spain to these territories, Liniers exceeded them all by his iniquitous proceedings in gaining partisans. These disorders, and the multiplied grievances of the public, at length produced a great number of malcontents in Buenos Ayres itself, and the authority of the Viceroy was combated not only in Monte-Video, but also at home.

In this interval, arrived from Spain, Don Joseph Manuel de Goyeneche, who had been appointed brigadier by the Provisional Junta of Seville, anterior to the formation of the Central Junta, and was sent as their Commissioner to promote unity and conformity of sentiment between the colonies and the metropolis. This man, whom America will ever blush to number among her sons, is a native of Arequipa, and a member of a rich family, in whose commercial concerns he had gone, some years before, to the Peninsula, where having dissipated the money intrusted to him by his father, he assumed the uniform of a captain of militia, and became one of the numerous class of loungers in Madrid. At the entrance of the French into that city, he obtained from Murat, a commission to go to America to support the French cause; but on his journey into Andalusia, he changed his mind, and obtained from the government of that province, the charge of Royal Commissioner for South America. On his arrival, he thought of nothing but making his fortune; and, adhering to the interests of those who had raised him to the rank of brigadier, recommended, that at all events the colonies should preserve their union with the provinces of Spain, which had now begun to raise their voice against France. In Monte-Video, he professed his assent to the views of its Majesty the Provincial Junta just then established, and stated, that his commission directed him to form others in all the cities of that continent. On his arrival at Buenos Ayres, and at his first conference with Liniers and the magistrates, he entirely changed his language, and declared, that the Monte-Videans deserved to be called refractory, for having constituted themselves in a manner not at all legitimate or proper in America. By this concession, however, he was enabled to procure a solemn adjuration of the capital to Ferdinand VII., which ceremony had been hitherto postponed, as well as a recognition of the Junta of Seville, as the legal representative and depository of the powers of the sovereign.

The commissioner assumed as many characters as the scene required. Seeing that the opponents of the Administration were headed by men respectable for their wealth and reputation, he was unwilling to leave means untried to conciliate them; and he therefore insinuated, that the precedent of Monte-Video was proper to be followed. The Cabildo, which was the centre of opposition to Liniers, gave the

signal for an insurrection on the 1st of January 1809, by forming a popular commotion in favour of the establishment of a Junta ; but this movement had only the effect of causing the banishment of its leaders, who were overpowered by the troops in the interest of the Viceroy, and by the preponderance of the magistrates, who were afraid of losing their posts.

It is worthy of note, that this conspiracy was entirely the work of European Spaniards, all the Creoles siding with the party in power ; and that the spirit of the latter was even so much averse from any proceeding repugnant to their scrupulous fidelity to the mother-country, that they rejected all the suggestions used by the metropolitans to incite them to this act of rebellion, which failed because they refused to co-operate. But although these seditious tumults were ineffectual, they brought to light a truth, which has proved very bitter to the Old Spaniards, namely, that the real strength of the country existed in the natives. At the same time, there arose between them a spirit of hatred and enmity so violent, as to be irreconcilable. The Viceroy, who owed his safety to the bayonets of the native troops, took care to flatter their patriotism, by congratulating them on their acknowledged superiority over their enemies ; thus following the maxim of *dividing in order to rule*, he added fuel to a fire which had been already kindled to an extinguishable degree.

While the Europeans of the colony, by their imprudent measures, were daily giving fresh motives for disgust to the natives, and temptations to devise means for eternally avoiding them, the metropolis was not more cautious in managing the intricate interests of the colonies, and in preventing that frequent collision which was detrimental to her own. The Central Junta was recognized and sworn to in Buenos Ayres with general enthusiasm ; and the first act in which that body manifested its sovereignty, was the mission of a new Viceroy in lieu of Liniers, who was to be sent under arrest to Spain. The dispute between the Creoles and the Europeans was decided entirely in favour of the latter ; the prisons in which the insurgents had been seven months confined, were opened ; and, in order that no doubt should remain as to the spirit of the decisions of the mother-country, Elio was raised to an employ, which gave him immediate authority over the troops. Nevertheless, the natives manifested a fresh proof of their ready deference to the will of their Trans-Atlantic lords, and admitted, without repugnance, the Viceroy Cisneros, who arrived among them in the beginning of the month of August 1809 ; but they resisted the promotion of Elio to the office of Inspector-general ; and the commandants of the different corps employed their influence to procure a relaxation of the orders respecting the transportation of Liniers, which was con-

ceded, and he was allowed to go and reside at Cordova. There this man of enterprise might have leisure to lament his surprise, for it is impossible to ascribe to other reasons his readiness to give up the command to his successor. It will, in the sequel, appear, that he left this quiet asylum, for which he was indebted to the love of the Creoles, for the purpose of fighting against them.

The posture of affairs, when Don Baltasar Hidalgo de Cisneros took the command, was by no means flattering; on the contrary, it presented the greatest difficulties that ever occurred since the conquest. The people began to abandon their habitual adoration of a government which was ever varying its form: their former sacrifices, and their bold defence, had been passed over without reward; they were laden with fresh grievances in various ways, and they were in a condition to avenge themselves. The coming of the chief calmed, for a short time, the heat of the parties, which had been excited by the former government: this, however, was but an apparent tranquillity, by which the ineptitude of Cisneros could not profit; it was like the extraordinary calm preceding a tempest, which a skilful pilot can reason from, but from which the ignorant can anticipate nothing. The public discontent was augmented by the exhausted state of the treasury, which called for some economical reforms in the military establishment; a measure which could not fail of producing uneasiness. Embarrassed in so many various ways, the Viceroy asked the advice of men capable of informing him; one of them* who, by his talents, his activity, and his patriotism, will occupy a distinguished place in the history of America, made the most eloquent and energetic representations in favour of a free trade with England, as the surest means of restoring happiness to the country, and of improving its finances.

The earnest complaints of the European Spaniards, exaggerated to such a degree as to represent the colony on the eve of a general revolt, had caused an unreasonable alarm to the central government, and had excited so much prejudice against the natives, that the most rigorous and extravagant instructions were given to the chief who came to restore order. It is not possible to conceive more harshness, more arbitrary conduct, or more injustice, than what was displayed under that system of the nation which was denominated popular. The Viceroy, in conformity to his instructions, began to apprehend all the individuals who were ac-

* Dr. Mariano Moreno, whose decease, in the prime of life, while on a voyage to England as envoy from the Junta of Buenos Ayres, deprived his country of one of its brightest ornaments. His abilities, as an orator and a statesman, justly gained him the appellation of the Burke of South America.

counted suspicious, and they were sent, without any form of trial, or the slightest public allegations, to the peninsula, where their common fate was, either imprisonment, or service in the ranks of the armies. Foreigners were persecuted in an equal degree, although many of them claimed protection on the ground of their former public services, or on that of having married and settled in the territory a considerable time previous.

The natural result of all this was, that the authority of the Viceroy was overthrown at the first shock. The 19th of May, 1810, was the day which put to the proof that old system which had rendered itself so odious: very dismal accounts had been received of the state of the mother-country, and principally of the Andalusias, the provinces that had made most stir in America: Cadiz was said to have surrendered, and the Central Junta dispersed, not only with ignominy, but under suspicions of treason. In this conjuncture, the Viceroy knew not what road to take; and his perplexity was manifested to the people by a proclamation, in which he expressed his concern respecting the precarious state of the peninsula, and, far from quieting their apprehensions, gave the most evident proofs of his own doubts and dejection. The Cabildo saw the necessity of immediately assembling to deliberate on the measures to be taken for preventing the multitude from forming a party of themselves to seize the government, for the continuation of which, as the fountain of authority was stopped, the men who held it could establish no claim. It is evident that, according to every principle of right, the magistrates could no longer exercise their functions, and that, the Central Junta being dissolved, Cisneros had no more title to the supreme administration of these provinces than the meanest citizen of Buenos Ayres. So far was this ferment from originating in any desire of independence which might be supposed to exist among the natives, that not a thing was done without the assent and concurrence of the chief, with whom all the individuals of the Cabildo, the majority of whom were European Spaniards, consulted, and, in conformity with him, convoked a congress on the 22d of the same month, at which the principal inhabitants assisted, in compliance with a citation made to that effect.

To the proceedings of this day, the Provisional Junta of Government now reigning in those provinces owes its origin: it was installed legitimately, and under the best auspices, for restoring tranquillity to the people, and for withdrawing them from that dangerous state into which they might at every step be thrown by the vicissitudes of the metropolis. Not a single instance of violence can be found to have taken place during that momentous crisis; and the magistrates, under the old system, have had no reason to complain of any vexation, except that of being

supplanted in their authority. Shortly afterwards, however, a great conspiracy was disclosed, that threatened to destroy a proceeding which the agents of despotism and corruption could not bring themselves to sanction. The passions of the functionaries from the metropolis began to take effect; these men could not easily condescend to regard as free men, those who had heretofore been slaves. Monte Video was the first town which refused to conform to the established alterations; and, notwithstanding that the first negotiations which were opened for securing the conformity of that people with the system of the capital, took effect for some time, yet on the arrival of a post at a subsequent period, announcing the installation of a Council of Regency, was sufficient to induce them to condemn the project, and even to insist that the restoration of the Viceroy was the only means of avoiding a rupture.

The Government of Buenos Ayres, who knew nothing of the Council of Regency but by report, not having received official dispatches to accredit its existence, and to justify its assumption of the rights of sovereignty, refused to acknowledge it under the pretext of these informalities; or, at least, deferred doing so, until they could satisfactorily examine the title by which that Council had placed itself at the head of the nation, after supplanting the Central Junta. And, indeed, if we are to regard the matter with the circumspection it merits, this reserve on the part of the New Government cannot be blamed; nor is it strange, that, after having admitted two reigns in the course of two years, they should rather hesitate at receiving a third, for otherwise there might have been danger, that, after blindly submitting, first to one and then to another, they would be driven at length to acknowledge the claims of Joseph Buonaparte.

On the side of Peru, the innovators beheld no clearer a prospect; Liniers had headed the opposition which was to destroy their projects; but of all the forces that could be collected in the interior provinces, only two small armies were formed, one under the command of that chief, and another in Potosi, under the orders of Marshal Nieto. Both were completely beaten by a military force which the Junta of Buenos Ayres dispatched against them, and the leaders in this disgraceful contest forfeited their lives for their rash enterprize. Liniers, Concha, Allende, Rodriguez, and Moreno, were executed in the vicinity of Cordova, pursuant to a formal sentence awarded against them as conspirators; and Nieto, Sanz, and Josef de Cordova, were put to death in the principal square of Potosi, with the public solemnity usual in such cases.

To the north, the province of Paraguay had adopted the example of Monte-Video, and had also united with the opposition, through the advice of Velasco the

governor : a force of five hundred men, under General Belgrano, was sent by the Junta in the month of October, 1810 ; but this interference was of little efficacy, and the inhabitants persisted, without adhering to the new system, until the intrigues and imprudent measures of their own chiefs obliged them to change their sentiments. The Paraguayans seized Velasco, and sent him as a present to the people of Buenos Ayres, in order to regain their friendship.

I am too much alive to the disasters of humanity, to enter into the details of the civil war and its attendant calamities, which continue to afflict these unhappy provinces ; and it is horrible to reflect that, while in Europe, the blood of men continues to be shed in torrents, America presents the sad spectacle of intestine divisions, in which her citizens are destroying each other through a difference of opinion concerning their own rights. The peninsula of Spain is strewn with the bodies of her sons, who have sworn to die in avenging the wrongs of their King, and in defending their liberty : these colonies, from one extremity to the other, are burning with the most violent ardour, and are disputing among themselves on the great question, Who is the representative of Ferdinand ; and what are the prerogatives which belong to them, as part of the state ? There, the French are the agents of injustice and desolation ; here despotism, selfishness, and ignorance, are tending to the same ends. Spaniards, if you wish that Providence should favour the issue of your contest with the Oppressor of Europe ; if you wish that the world should deem you capable of vindicating your rights, and securing them, go not to the inoffensive plains of the Rio de la Plata to maintain that oppression which in your own country you detest ; pledge not yourselves, that the arbitrary power and the tyranny of your kings, which you yourselves acknowledge, shall prevail eternally in America ; employ not your strength in perpetuating those barbarous laws which were dictated in the ages of darkness and violence. As yours were the arms which gave to the crown of Spain these immense possessions, let not their inhabitants have to reproach you a second time with having enslaved them. And you, Americans, contemplate the history of nations, and thence learn how ye ought to conduct yourselves in the perilous crisis in which ye stand. Look on those men, whom difference of opinion has caused you to regard as enemies ; they are your own brethren, the loss of whom would be sensibly felt in agriculture, in arts, in your domestic economy : avoid shedding blood, which has already begun to stain the pages of your history. I do not exhort you to rebellion, but to be firm and wise in the assertion and establishment of your rights.

(B.) Page 110.

BEFORE I took leave of Brazil, I was desirous of submitting to His Royal Highness some observations relative to his farm of Santa Cruz, in furtherance of the project I had the honour to propose to His Excellency the Conde de Linhares*, eighteen months before, for the better management of that fine tract of land. These observations, of which I here present to the reader an abstract, relate to two objects; first, to the means of rendering the farm a model of agricultural improvement for the planters of Brazil, and next, to the improvements by which its lands from their superior quality and their convenient situation might serve, in part, to supply Rio de Janeiro with its productions, and might sustain a great number of excellent cattle to be fattened for the consumption of that city. I anticipated the fate of these observations before I wrote them; for practice is widely different from theory, particularly to those who were never for a moment engaged in considering such subjects, and are certainly incapable of comprehending them. To teach men modern agriculture, who have only lived to study dress and parade, would be an useless task; for when principals are totally ignorant of what they undertake or superintend, they will have neither the power nor the inclination to maintain it in credit, much less, bring it to perfection.

Thus it is with Santa Cruz, the grounds of which are superlatively better than any I ever saw in Brazil, and highly calculated for experimental and general agriculture, having plains, hills, rivers, rivulets, and varieties of soil and climate.

Inclosures for the cattle, to a considerable extent, should be the first object of attention. Next, a quantity of land, not less than 800 or 1000 acres in situations subject to irrigation, should be sown with artificial grasses, particularly those most congenial to it; if this land were well managed, its produce might be cut at least four times a year. A peculiar mode of planting and of management would be necessary; here the plough should be employed instead of the hoe, and other methods resulting from sound practice should be resorted to.

* It is to be observed, that by the laws of Portugal, no person can address a letter or memorial of any kind to the Sovereign; all representations must be made through the ministers.

As this would be a principal object, and would well reward the labour it occasioned, every possible attention should be paid to it. Santa Cruz possesses inexhaustible strata of shell-lime, and various manures in abundance.

The quantity of land before-mentioned being inclosed and planted, the next object should be to select a proper number of young cows for milking, which might be augmented in proportion as more land was brought under artificial grass; five or six hundred would be sufficient for the commencement. The management of them would, I am aware, require more than common attention, and in a concern on so great a scale, some mistakes and disappointments must necessarily occur. Their breed should be an object of peculiar care, and the best of both species should be introduced; the pasture of the cows should be free from young cattle, horses or mules; they should be treated with care and tenderness, and live in the strictest quiet.

The meadows inclosed for their pasture would be very insufficient in time of scarcity (the dry season), therefore the corrals or places for milking the cows should be well supplied with grass, and to these places they would soon be accustomed to come, to be milked and fed. But such practice will appear ridiculous to the present managers, who think it is right that cows should be kept fourteen hours in a pen without food before they are milked, which is certainly analogous to the idea of starving them to make them fat.

It is impossible to calculate the quantity of milk, butter, or cheese, which might be obtained from five or six hundred cows, as that would depend on many local circumstances, and a variety of experiments would be required, to arrive at any degree of accuracy; but suppose the above number to give only 600lb. of butter per week; in England they would give *more* than double that quantity; and here it is impossible to calculate what the difference would be in a quantity of cows fed on artificial grasses, accustomed to be regularly milked, and treated in a manner so superior to that now practised. The augmentation produced would exceed any statement I durst give; for in various parts of Brazil, I have known cows even under miserable treatment yield from two to three gallons, and instances of this kind are not uncommon in the season of abundance. In England, a cow in the vicinity of the metropolis may be estimated to leave a profit of 10l. per annum; in various parts of the country from 7l. to 10l., according to the locality. Here, although land and cattle are dear, yet we find this produce cheaper than in any part of Brazil. At Rio de Janeiro, good salt butter is worth from 3s. 6d. to 4s. per lb.; and I have even known it to sell at nearly double that price; therefore, it is fair to suppose, that good fresh butter

would sell for at least as much. Thus in Brazil, land and cows are of little value, and their produce is extravagantly dear. Is their milk not so good as that of any country in Europe? Equally so. Does it not yield as much cream? As much and as good as I ever witnessed any where. Then is the heat of the climate an obstacle? None, certainly, if proper conveniences were made. The winter in England is much more unfavourable for dairy operations than the hot weather in Santa Cruz. Then it may be said, they give but little milk:—it is impossible that they should give more under such treatment. But to make this an object of profit, an entirely contrary system must be adopted, founded on rational principles and pursued with industry, and not the offspring of ignorance, idleness and folly. Females ought alone to be employed in every thing relative to the dairy and milking; at present, that and other operations are performed by the most useful men on the estate. If good roads were made, and a proper number of carts and draught cattle were provided, comparatively few men would be required to till the land, keep it in cultivation, take care of the cows, feed oxen, &c.

The next object would be a proper building for a dairy, replete with all the requisite utensils and conveniences *, and under the superintendance of a person conversant with the business, whether in the form of a Commendador or a military officer it is of little importance. If he know his duty, he ought to be without control, and depend upon his credit in whatever relates to it; if he be ignorant of his duty, why place him there? A courtier has very different views and habits to a farmer, and no one would ever think of entrusting the management of a farm to such a person.

I did not introduce the making of cheese at Santa Cruz for reasons best known to myself. This branch of rural œconomy, and that before mentioned, are objects of importance, if profit alone be considered; but they are still more so, as tending to give an example to the whole empire. How worthy it would be of the greatness of the Sovereign to make his farm the school from which his subjects might learn new modes of agriculture, the place to which intelligent strangers from all countries would be encouraged to resort, and to contribute useful information. Communications might be opened with the Cape, Ceylon, India, and other parts of the world, from which the greatest benefits would result to the subjects as well as to the state.

* For this purpose a central situation should be chosen, where cellars could be formed of sufficient capacity, and every practicable means used to obtain a circulation of air, and as much as possible to exclude heat.

The next object is the fattening of cattle for Rio de Janeiro, a place where good meat can scarcely be said to be known. Oxen of a certain age should be brought from the interior, and tied up in proper feeding-houses, as they would be liable, if turned loose, to get into the marshes and be lost. Two or three hundred would be sufficient to begin with : they might cost, when brought to Santa Cruz, four or five milreis each, and would be fattened in three or four months, when they would sell for eleven or twelve milreis each, more or less. They would require artificial food most convenient to the soil and climate, and a quantity of land under the best cultivation, to maintain them. Nay, I think the feeding might be extended, so as to sell two or three hundred monthly. It must be understood, that a variety of sheds for feeding-houses are indispensable. A farm (like Santa Cruz) without conveniences is a mere waste of land ; for store-houses, and appropriate buildings of every description, are equally necessary as a dwelling-house. In the poor hovels occupied by the worthy tenants of Santa Cruz, not the least attention has been paid to the erection of barns or other out-houses, for produce of every description ; indeed, I again repeat that they are miserable dwellings, hateful to those who occupy them for want of comfort. If, by way of contrast, two neat farm-houses were to be built with every convenience, after the most approved English plans, having certain portions of land allotted to them, with good roads, and water brought if necessary, for the purpose of irrigation, they would be perfectly adequate to pay a rent equal to the interest of money laid out upon them ; and it is probable the experiment would be attended with the happiest consequences. Then would His Royal Highness soon find his rich lands adorned with beautiful villas, and the road from thence to Rio de Janeiro would be covered with vehicles conducting their produce to that market. But liberality so different from the present narrow principles which direct the management of that estate, cannot be expected from those who strive all in their power to oppress the tenants instead of encouraging them. These unhappy men, wearied by such grievances, and seeing no prospect of amelioration, are daily leaving the estate under the conviction that no change can be for the worse ; and there is reason to fear that His Royal Highness will soon find his farm a desert. The probable result will be, that he will be persuaded to consent to part with it ; and the same disingenuous practices will take place, which wrested from the Viceroy the only two sugar-mills on the estate. This hint may possibly be given too late ; for I have reason to suppose, that the fate of Santa Cruz was decided before I left the country. If it is not too late, it may serve to frustrate the views of those who have ever coveted this princely domain.

Among the first objects of experimental agriculture, I may mention the growth of hemp, for which some parts of the rich plains of Santa Cruz are so well calculated. This plant is indigenous to hot climates, and, in cold countries, is produced only during the hot season. Some which I sowed in my garden gave the most flattering appearances, and, in six weeks after being sown, was eighteen inches high; but it was capriciously ordered to be cut down on my leaving the estate. As an excellent substitute for this plant, I may mention the aloe, which grows spontaneously in great luxuriance, and makes very good fences. From its fibres I made some twine, which I am persuaded might have been manufactured into strong and durable canvas.

There is a great extent of low land, for the greater part of the year a continued bog, in which many weak cattle are daily suffocated; but, under the management of a skilful drainer, it might produce an abundance of fine grass. The large plains, so favourable to the growth of rice, are uncultivated; nor is one piece of machinery employed to take the rusk from that grain, to clean coffee, or to prepare mandioca. A multitude of persons are employed in these operations, which are extremely ill-conducted, and are subject to every species of speculation.

The rising grounds or hills present large tracts fit for the growth of coffee, cotton, mandioca, and other produce. I have not touched upon sugar, because, at present, Santa Cruz has no mills; the best lands for the growth of that article were sold, together with the mills, some years ago. One of these, situated on a river called Taguai, is at least equal, if not superior, to any, in the whole extent of America. It was built by an able engineer on the most scientific principles, and has two sets of rollers and two ranges of boilers. The rollers are worked by one simple upright shaft moved by a horizontal water-wheel. It is a most capacious building, not less than seventy yards long by about twenty-five wide, with a distil-house and proper drying-houses at the farther end. This establishment, and the lands annexed to it, if worked to their extent, are capable of producing more than a thousand tons annually.

The indigo of this country, as I have before observed, is not good; probably a better kind might be procured from seed brought from India; and no place could be found so favourable for the experiment as the royal farm. A large field is here open for the introduction of cochineal, opium, tobacco, &c. which might be effected without expence, and would probably yield some profit.

The excellent strata of lime which are found on the estate, might be worked to great advantage, not only for the purposes of agriculture, but for building; and

large quantities of it might be sent to Rio de Janeiro. The brick-yard and tannery, if well conducted, would yield considerable profit.

At Santa Cruz, where it might be expected that superior management would be found, there is hardly a single department which would not be better conducted if left to the care of the negroes themselves. No provision is made in the time of abundance to meet the season of scarcity. Every thing is done without foresight; and so great is the neglect, that when His Royal Highness pays a visit to the farm, two or three hundred negroes are employed in cutting grass for the twenty or thirty mules of His Royal Highness's equipage. This calls aloud for some mode of culture to prevent so grievous a misapplication of useful labour.

I may here touch upon another point of no less importance than the management of the whole concern. It is difficult to conceive, why whatever relates to His Royal Highness, should be conducted without profit, and with the most miserable meanness. The goodness of the Prince is acknowledged by all his subjects, and his desire to promote human happiness is equalled only by his greatness of mind. Yet among those who manage his private concerns, there is an inaction and a tyrannical narrowness without example. This establishment, which ought to be governed as private property, supports a train of intendants, majors, administrators, alms-sheriffs, secretaries, clerks, serjeants, corporals, soldiers, and messengers without number, who give it more the appearance of one of the old German principalities, than of a rural farm. With all this ostentation, there is not even a shadow of that liberality which should attend it. The good tenant who comes leagues to pay his rent, wet and fatigued, is never invited to take any refreshment; to the weary traveller no door is open; neither for love nor money can he procure a hospitable shed, and he is obliged to seek some cottage or vend that will administer to his necessities. In fact, through the conduct of His Majesty's servants, the misery of Santa Cruz has become proverbial, and, like a haunted house, it is detested and avoided by all who know it.

Such is the present state of the royal farm, and such the conduct of those who are appointed to manage it; and, although an Englishman of talents, as I am informed, has been placed there, yet I venture to predict that he will leave it in disgust, and will prefer to live in any remote part, rather than submit to the vexations to which he will there be exposed.

APPENDIX, (C.)

IN page 260 of this work, I have stated, that it was my intention to enquire into, and to make some observations on the present regulations relative to diamonds. These beautiful gems have been found in such abundance in Brazil, as to supply not only Europe, but Asia ; as those of India were scarce, and frequently withheld from sale, diamonds from Brazil were sent thither, and usurped their name. The question we are at present about to examine is, how far it would be consistent with the interest of the Portuguese Government, to permit the searching for diamonds, in the same way as for gold, under peculiar laws. The monopoly is ineffectual, because the diamonds are found in so many parts widely distant from each other, that it is impossible to prevent the searching for them clandestinely. The attempt to preserve grounds known to contain these gems, by forming a distacamento, has never produced any good effect ; and it is by no means improbable, that the best of these (supposed) preserved lands are already worked, therefore the soldiers are guarding the chest after the treasure has been taken away. How many places might be mentioned out of the district of Cerro do Frio, where troops of negroes daily work ! It has been stated, that Government probably receive little more than a moiety of the gems found at their expence ; if so, it is certainly time to abandon so bad a trade, or change the system altogether. Is it the interest of Brazil to keep her sons in continual torture and fear respecting these precious gifts, which the bounteous hand of Providence has placed there ? But this monopoly is in a fair way to destroy itself, and must, of course, soon give way from necessity, for there are not at this moment purchasers for the treasury diamonds ; they may remain year after year, until the interest outvalues the capital. How happens it, that diamonds, in the hands of individuals, meet a ready sale ? First, Because they are better stones, and are offered in quantities more convenient for the purchasers : Secondly, They are frequently bought at a less price than that paid by Government for those procured from their own establishments. If they were subject to pay a fifth, Government would have such power as to enable them to command the market ; and if they should become cheaper in Europe, the demand for them would become more general, therefore their price would not be likely to fall in Brazil ; and, even if it did, is it not the blindest policy for the court to put such a yoke round the neck of her excellent subjects, who venture their lives in track-

less deserts searching for mines, and exposing themselves to every danger? Would it have been possible for Portugal to colonize Brazil if there had been no gold mines to attract adventurers? To deny men the treasures with which nature has enriched the country, is to oppose one great check to its population; for the example of one adventurer becoming rich, would be the means of inducing hundreds to follow him. Under the present system, there is so great a struggle between the temptation of becoming suddenly rich, and the fear of being ruined by detection, that when a man finds a diamond by accident, he knows not whether to appropriate it, or to surrender it to the Government; even in the latter case, he has little prospect of reward, and runs the risk of being accused as a smuggler. Instances have been known of men who have thrown away the diamonds they have accidentally found*, rather than involve themselves in ruin, either by keeping them, or delivering them to Government.

It has before been shewn, that Government are the greatest gainers by the diamonds which are sold clandestinely; and if individuals were allowed to trade in them, the state would undoubtedly be benefited by it. For it is certain, that a Brazilian farmer or miner would prefer necessaries, such as iron utensils, clothing, &c. which add to his comforts and conveniences of life, to articles of ideal value, which in reality have come into his hands probably without difficulty or expence. Thus the peasantry would draw valuable produce from other countries in exchange for what cost them comparatively nothing, and, by enriching themselves, would augment the revenues of the state.

If the diamonds were made liable to pay a fifth, either in kind or in value, it is probable that there would be less smuggling; and that practice might be still more restrained, by something like the following regulation: every person finding diamonds should be obliged to register them; also, to take out a certificate authorising him to dispose of them in whatever manner he thinks proper. It would certainly add to their importance, to make them subject to a small duty †, on being lawfully transferred from the buyer to the seller, by which means they would come into immediate circulation and represent real property: thus, after yielding a profit to each person through whose hands they passed, they would finally be exported; and, as long as diamonds continued an article of distinction, ornament,

* Formerly, if any diamonds were found in a gold-washing, the owner was obliged to desist from working it, and the ground was appropriated by government. This law is now no longer in force.

† It is reasonable to suppose, that few persons would hazard the penalty incurred by dealing in diamonds clandestinely, when, by paying a duty, they could bring them fairly into circulation.

and elegance, Brazil would lay under tribute every court in the civilized world.

The Dutch were artful enough to poison the ears of the ministers of Portugal against the proposal of making diamonds a free trade, and assisted in the persecutions against those unfortunate sufferers who were detected in possessing them; but surely that narrow-minded and self-interested policy is now done away with; nor would it be credited in modern history, that the Government of Brazil, for a trivial, pecuniary profit, should be the dupes of their own bank and a few interested strangers.

Branches of the Revenue.

The following is a statement of the various branches of the revenue of Brazil, which is perhaps unequalled by that of any other country consisting of the same population :—

1. A fifth upon all the gold obtained in any and every part of Brazil.
2. A duty of fifteen per cent. upon all merchandize entered at the Custom-house and imported, except what is imported in Portuguese ships, which pays something less.
3. A small tax upon exports.
4. Tythes, or ten per cent. upon the productions of the land. This branch of revenue yields a large income to the state, to which it has belonged since the first settlement of the colony, when the reigning Sovereign, by contract with his Holiness, agreed to pay the salaries of the clergy, in order to induce them to go to that remote and uncivilized country. It is also claimed by the state in virtue of the order of Christ, of which the monarchs of Portugal are grand-masters. It is portioned into distinct districts, each of which is either contracted for, or put up at auction separately in the treasury under such arrangements as to be allotted to those who have most interest. The several renters collect it by ascertaining the number of negroes upon every estate, or possessed by every house-keeper, and agree to receive a certain rate per head instead of taking it in kind. The amount for which the various tythes are sold it is not easy to calculate, but it must be very considerable. I am almost certain that the tythes of Rio Grande alone were sold for ten thousand pounds per annum for three years*. In Bahia, and other places,

* This revenue arises from hides, which are subject to this duty.

where sugar and cotton are taken in tythe, the amount must be enormous. The contractors derive great emoluments from these imposts; in one of the smallest districts, Canta Gallo, the population of which is less than any other in proportion to its extent, the profits were calculated to yield above 600l. per annum.

5. Indulgences, which are disposed of under the same regulations as the tythes, the contractor of the district appointing agents in every parish to sell them for him.

6. A duty upon every thing that enters the mining district, which is paid on passing the register of Matthias Barbosa, or on crossing the Paraibuna. This tax is about six shillings the arroba, or somewhat more than twopence per lb. for all commodities indiscriminately. New negroes pay ten milreis each. Oxen going to Rio de Janeiro pay two milreis per head.

A considerable sum arises from the tolls paid on passing the various rivers. Two milreis for each mule, unless with cargo.

A new tax of five reis per lb. has been imposed on all butcher's meat sold in the principal towns.

Spirituuous liquors transported to Rio de Janeiro pay ten dollars per pipe.

A new tax has been laid upon the rents of houses, which is levied very favourably.

The gold dust that was permitted to circulate in the mines has been called in, and paper-money peculiar to the district has been issued, to the amount of a hundred thousand pounds sterling.

A considerable sum has been produced by the stamping of dollars, which were received at seven hundred and fifty reis, and re-issued, after being stamped, at nine hundred.

View of the State of Society among the Middling Classes, employed in Mining and Agriculture.

We are naturally led to imagine, that, in a country where mines of gold and diamonds are found, the riches of the inhabitants must be immense, and their condition most enviable; the Portugueseze themselves, who reside in the mining districts, encourage this supposition; and whenever they go to Rio de Janeiro, do not fail to make all possible shew and parade. But let us view them in the centre of their wealth; and as a fair criterion of the middling classes of society, let us select a man possessing a property of fifty or sixty negroes, with *datas* of gold mines, and the necessary utensils for working them. The negroes alone are worth,

at the low valuation of 100 milreis each, a sum equal to 1,200l. or 1,500l. sterling; the *datas* and utensils, though of value, need not be taken into the account. Suppose this man to be married, and to have a family: What is the state of their domestic concerns, their general way of life? May I be allowed to describe them in the language which truth dictates, without exaggeration or extenuation. Their dwelling scarcely merits the name of a house; it is the most wretched hovel that imagination can describe, consisting of a few apartments built up to each other without regularity; the walls wicker-work, filled up with mud; a hole left for a frame serves as a window, or a miserable door answers that purpose. The cracks in the mud are rarely filled up; and in very few instances only have I seen a house repaired. The floors are of clay, moist in itself, and rendered more disagreeable by the filth of its inhabitants, with whom the pigs not unfrequently dispute the right of possession. Some ranchos, it is true, are built upon piles; and underneath are the stables, &c.; these are certainly a little superior to the former. They are built so from necessity, where the ground is uneven or swampy; but it may be easily conceived, that the disagreeable effects produced by want of cleanliness, must in these instances be increased by the effluvia from the animals underneath, which I have frequently found intolerable.

The furniture of the house is such as might be expected from the description above given. The beds are very coarse cotton cases, filled with dry grass, or the leaves of Indian corn. There are seldom more than two in a house; for the servants generally sleep upon mats, or dried hides laid on the floor. The furniture consists of one or two chairs, a few stools and benches, one table, or perhaps two, a few coffee-cups and a coffee-pot of silver; a silver drinking cup, and, in some instances, a silver wash-hand bason, which, when strangers are present, is handed round with great ostentation, and forms a striking contrast to the rest of the utensils.

The general diet of the family consists of the same articles which have already been particularized in treating of St. Paul's. The only beverage is water; and nothing can be more frugal than the whole economy of the table. So intent is the owner in employing his slaves solely in employments directly lucrative, that the garden, on which almost the entire subsistence of the family depends, is kept in the most miserable disorder.

In the article of dress, they do not appear more extravagant than in that of food. The children are generally naked; the youths go without shoes, in an old jacket, and cotton trowsers; the men in an old capote or mantle wrapped around them, and wooden clogs, except when they go from home; and, on those

occasions, they appear in all their splendour, forming as great a contrast to their domestic attire, as the gaudy butterfly does to the chrysalis from which it springs.

It might be expected, that however penuriously the general concerns of the family were conducted, at least some degree of attention and expence would be bestowed on the dress of the females; for the test of civilization among all nations is the regard paid to the fair sex, on whom the happiness of domestic life depends. Yet the general poverty and meanness of their attire is such, that they reluctantly appear before any one, except the individuals of their own family.

In short, in all those departments of domestic economy, which to the middle classes of other civilized nations are objects of expence, the Brazilians exercise the most rigid parsimony. At first, I was inclined to attribute this disposition to a love of money, which prompted them to avoid all extravagance; but, on closer observation, I was surprised to find that it originated in necessity. They generally run in debt for the few articles they have to purchase, and sometimes find it difficult to maintain their negroes. If they purchase a mule, it is at one or two years' credit, and, of course, at double its ordinary price.

In such a family as that above described, the sons, as might be expected, are brought up in idleness; they are merely taught to read and write; rarely do they attend to the mining department; they learn no trade, nor are they instructed in any useful employment; for a miner, perhaps an ensign or a lieutenant of militia, would think it a disgrace to put his son apprentice to a mechanic. Suppose the father of this family to die when the sons have just attained the age of puberty. They are now for the first time obliged to think of providing for themselves. Educated in poverty and pride, they have learned to think all occupations servile, and their own is generally so poor as to be hateful to them. If they agree, not to divide the negroes, it generally happens that they run into debt, and continue in wretchedness; if they divide them, each takes his course, and adventures for himself, and in a short time, they are generally obliged to part with their slaves, and exist in indigence. Every useful pursuit and every comfort is neglected for the sake of seeking hidden treasures which very rarely are found, and which when found are as rarely employed to advantage, but rather serve to increase the idleness of the owners.

Few, very few of the numerous class of miners from which the above instance is selected are rich, few are even comfortable; how wretched then must be

the state of those who possess only eight or ten negroes, or whose property does not exceed three or four hundred pounds.

Thus situated in one of the finest climates in the world, with rich lands full of the finest timber, abounding in rivulets and water-falls in every direction, containing, besides precious minerals, iron ores, and almost every other useful product, the inhabitants of Brazil, though secured from absolute want, remain in indigence. It is true, the miner procures his gold by great labour, but this need not preclude him from improving his domestic condition. Were his hovel converted into a house, his slaves better fed and lodged, and his family better provided for, his whole affairs would receive a new impulse, and every part of his property would become doubly productive.

Negroes employed as Messengers.

One description of men whom I have omitted to mention before, are negroes employed as messengers by the various chiefs in the Capitanía of Minas Geraes. The men selected for this employment are the most trusty and able-bodied that can be found. Their letters are locked up in a leathern bag, which they buckle round them, and never take off until they deliver its contents. They carry a gun and ammunition with them to defend themselves, as well as to provide themselves with food. Wherever they halt, they are sure of a kind and friendly reception; for nothing can exceed the cordiality with which the negroes welcome each other. These men are trusted on very important missions, and are dispatched to every part of the Capitanía. On urgent occasions, some of them have performed journeys with astonishing celerity. I was most credibly informed, that one of them had been known to travel seven hundred miles on a mountainous road in sixteen days, though that distance usually occupies twenty or twenty-one days. The men are generally tall, and of spare habit; they are accustomed to light food and long abstinence.

Diseases peculiar to the Country.

Of diseases I did not hear of any that were contagious, except Psora, which sometimes prevails among the lower orders, who rarely use any remedy against it, nor will they hear of sulphur, as they believe it to be fatal. Colds, attended with fever, are the most general complaints; but consumptions are rarely heard of. Among the miners, I saw no symptoms of elephantiasis, though that disease is so

common in many other parts of Brazil, particularly on the sea-coast. The sciatica which afflicts travellers after long journeys on mules, is attributed by the people of the country to the bodily heat of those animals, which is much greater than that of horses, and communicates to the loins of the rider, occasioning almost constant excruciating pain, which frequently becomes chronic, and sometimes incurable. Being, on my return from the diamond district, much tormented with this complaint, I was naturally led to make inquiries on the subject, and was informed, that a person in the house where I then resided, had returned from a long journey in the same predicament, and was about to undergo the mode of cure commonly practised in the country. I was desirous of inquiring the nature of it, and begged to be introduced to him. On conversing with him, I found that his symptoms were similar to mine; he complained of great pain in the os sacrum, and down the left thigh to the knee, which afflicted him most when in bed, where he could not bear to lie in any posture for half an hour together, but was obliged to rise and wait until the warmth occasioned by the bed was abated, when he lay down again. Thus he could get no sleep night or day. On asking if he had tried any external application as a stimulus, he replied, that neither that nor any other remedy was of the smallest avail, except the one peculiar to the country. The operation was as follows:—The patient lay down on a bench with his back upwards, and a youth, twelve or fourteen years of age, knelt upon his loins, and continued to trample them (as it were) with his knees for about the space of half an hour, apparently reducing the muscles almost to a jelly. In a few hours afterwards, the part became highly discoloured, and had the appearance of being very much bruised. If one operation had not the desired effect, another, and even a third, would be had recourse to. It must be confessed, that this remedy, in removing one evil, occasions another; but the advantage is, that the latter is of short duration, whereas the former endures sometimes for life, and gives continual affliction. In some cases it has been applied with success, but, in others, it has entirely failed.

On the Use of Mercury in the Mining Department.

The Government of Brazil would find it highly to their interest to promote the use of mercury in the gold district. The process of amalgamation is so simple, that there would be no difficulty in introducing it generally among the miners; and it would save much time and labour in the last operation of washing, or what is called purifying. It is possible, also, that by the application of muriate of soda,

some silver might be discovered in antimonial ores, also in pyrites which accompanies gold.

Perhaps it may not be improper, in this place, to describe the method pursued in working the silver mines on the coast of Chili, which may be estimated to produce about a million of dollars annually. Some of these mines are full fifty yards deep; and we are told of one nearly as many fathoms. It is probable that they are sunk upon the vein; and they are so ill secured, that they frequently fill, and bury those within them. The ore, a sulphuret of silver with antimony, lead, and blende, is brought up on the shoulders of wretched Indians, who descend and ascend by insecure posts with notches cut in them. They are total strangers to the operations of boring and blasting, and use only miserable hammers and wedges. The gang with the ore is, in some places, reduced by means of a large stone, ill-constructed, not unlike a bark-mill; in others, it is reduced by hand, and, when sufficiently fine, it is washed by several operations in a slovenly manner, until the metallic part alone remains, which is not unlike lead ore dust in appearance. This is formed into small heaps, perhaps about 100lb. in weight, to each of which are added about 20 or 25 lb. of muriate of soda. This is triturated and worked both by hands and feet for three or four days. When the soda is judged to be sufficiently incorporated with the metal, mercury is used in the proportion of five to ten per cent., and is triturated until it loses its globular form; to prove which, a small bit is rubbed upon a horn, or upon the thumb-nail, and if any globules appear, however minute, the trituration is continued until they totally disappear*. To this mixture the workmen frequently add filth, rags, &c. place crosses upon the heaps, and use many ridiculous ceremonies dictated by folly and a belief in necromancy. At length the mercury unites itself to the silver, and forms with it a paste-like mass, separating itself from the remainder, which is thrown away. This mass is put into goat-skins, and, by twisting and squeezing, a great part of the mercury passes through. The remainder is sublimed by heat, and is condensed with more or less loss, according to the mode applied, and the skill of the operator. The little gold which is procured in some of the mines on this coast undergoes a similar process; afterwards, the remainder is melted and assayed.

In this part of Chili, the state of society is wretched; gambling is a general vice, and murder is scarcely deemed a crime. The greatest depredations are committed with impunity, nor do the crosses placed on the heaps protect them from

* It would be interesting to enquire, in what manner the salt acts upon the ore containing silver, for without it the mercury has no effect.

plunderers ; so that, when a mine proves good, the hopes of the proprietor are often frustrated through the poverty and envy of his neighbours.

The copper mines of Guasco, Copiapo, and Coquimbo, are wretchedly worked, nor would it perhaps be safe to introduce other methods. The copper is smelted in a hearth with bellows and wood ; and if, when it is run into cakes, it has the appearance of copper, they do not smelt it again, but if it is so covered and intermixed with slag, as not to be known, it is broken up and undergoes a second smelting, when not unfrequently slag is placed so as to be in the centre. These, and other deceptions, have brought the trade into great discredit. The copper is sold from eight to eleven dollars per 104 lb. It is considered a poor trade, though the Spaniards always think the Chilian copper, and even the timber which serves for fuel, to be full of gold.

Crystalline forms of Diamond, Topaz, and Tourmaline.

Diamond

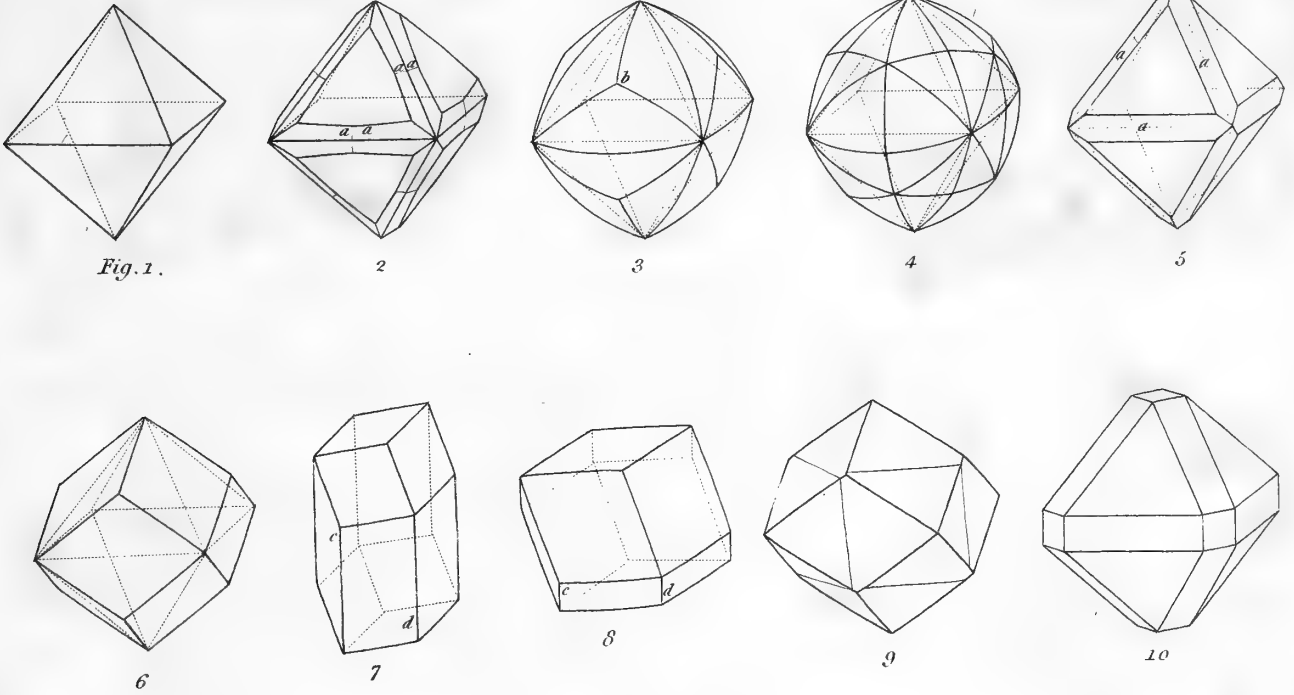

Topaz

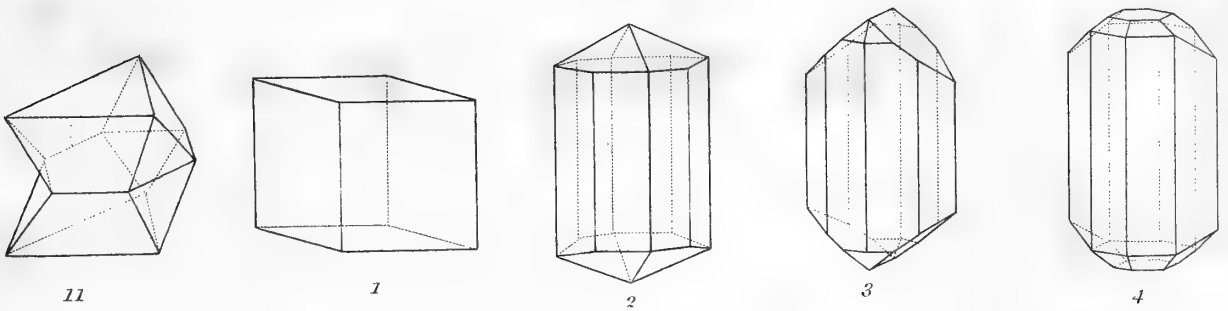

Tourmaline

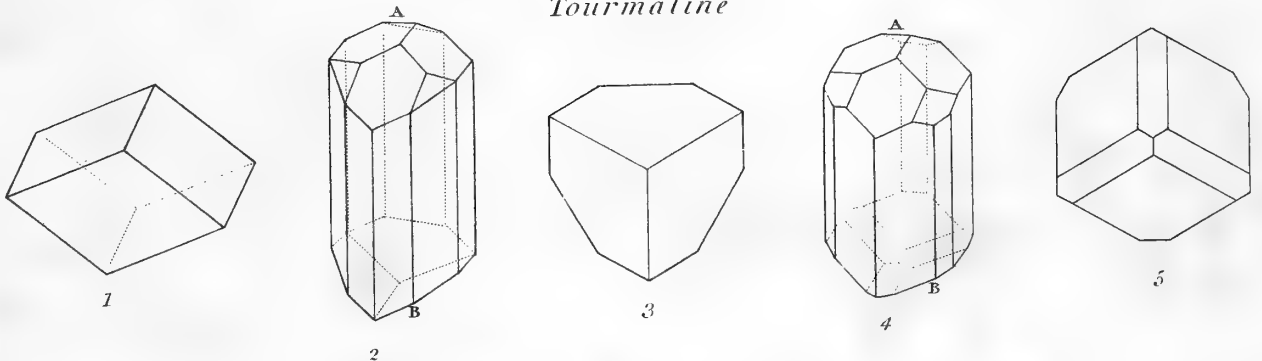



Chromate of Lead.
p. 269.

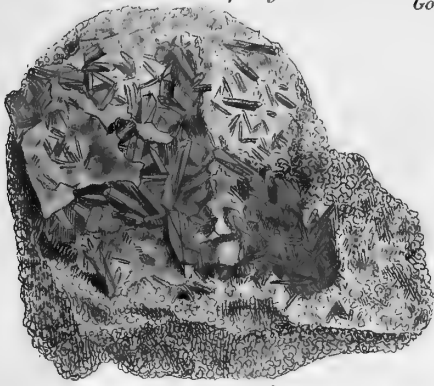

Gold Crystalliz'd in Cubes.
p. 225.

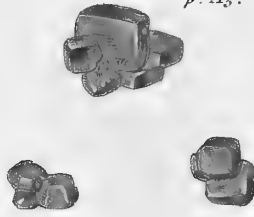

Gold in Chlorite.



New variety of Hydrargillite.
p. 182.

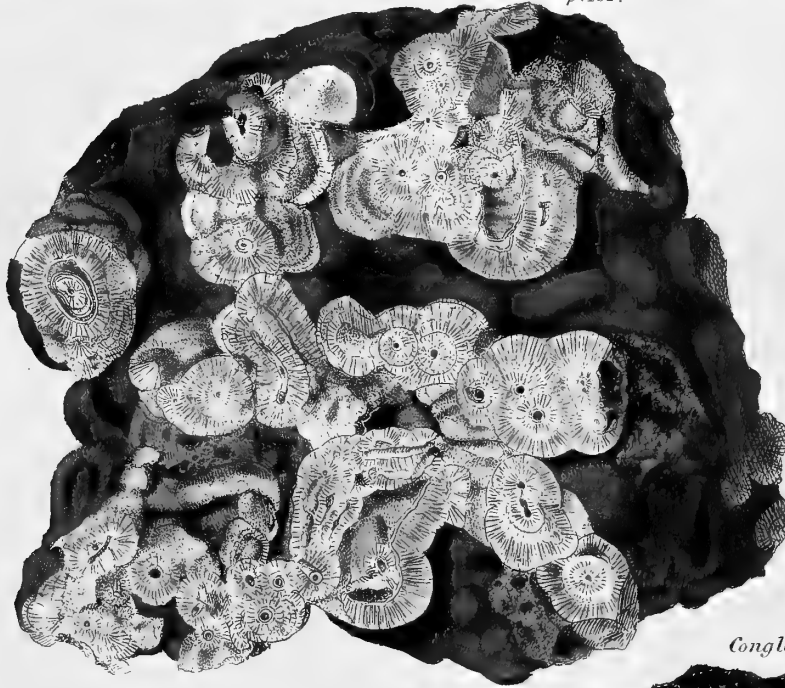

*Conglomerate mass containing Gold
and sometimes Diamonds.*
p. 222.

Red Oxide of Titanium.



Minerals collected by the Author during his Tour.



Variety of *Helix Ovalis*
p. 199.

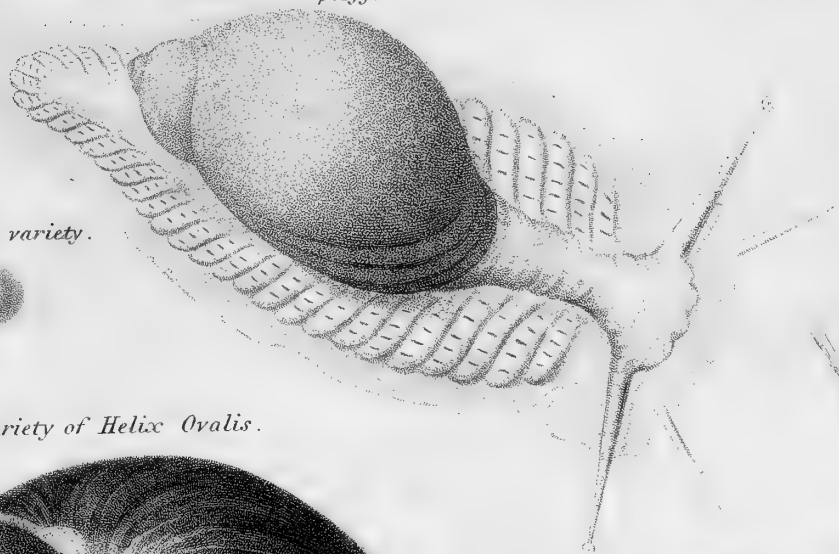

Egg of the above variety.

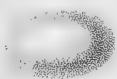

Variety of *Helix Ovalis*.



Cluster of Eggs left
on a rush by
Helix Ampullacea.



Helix Ampullacea.

N^o 1

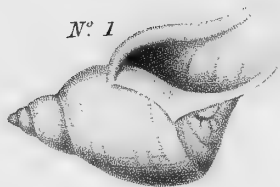

2

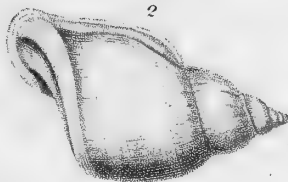

3

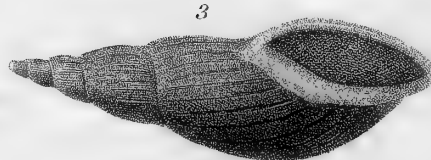

Helix Ovalis Linn.



4



5



6



N^{os} 1, 2, 3, 4, 5, 6. Land Shells which we have not found described.



*EXPLANATION of the Plate of Crystals of Diamond, Topaz, and Tourmaline.**Diamond.*

- Fig. 1.—Primitive crystal, a regular octaëdron, from which all the other forms may be conceived to be derived.
- Fig. 2.—Octaëdron with edges replaced by four faces, two and two making such obtuse angles at *a a*, as sometimes to be scarcely perceptible ; and then it passes into Fig. 3., when the faces become so broad as to meet in the point *b*, forming a three-sided pyramid on each face of the primitive crystal.
- Fig. 4.—When the angles at *a a*, Fig. 2., are decidedly marked, and the faces meet, as at *b*, Fig. 3., a pyramid of six faces is formed on each plane of the primitive crystal.
- Fig. 5.—If the edges of the primitive crystal be replaced by planes *a a*, an octododecaëdron, or solid of twenty faces, will be formed.
- Fig. 6.—If the planes *a a* of Fig. 5. be conceived to meet, as at *b*, a rhomboidal dodecaëdron will be formed.
- Fig. 7. and 8.—If the planes *a a a* of Fig. 6. be conceived to be extended as in Fig. 7., or contracted as in Fig. 8., they may be considered as six-sided prisms, terminated by three-sided pyramids, in which the terminal planes are set alternately on the edges *c*, *d*, of the prism.
- Fig. 9.—Sometimes the faces *a a a* of Fig. 6. are divided in the direction of the shorter diagonal, as shown in this figure.
- Fig. 10.—If the edges and the solid angles of the primitive crystal be replaced by planes, the crystal (Fig. 10.) will be produced ; and if the edges be very slightly and the angles very deeply truncated, a cube will be formed. This latter is one of the rarest forms of the diamond.
- Fig. 11.—If Fig. 1. be conceived to be divided parallel to two of the opposite faces of the octaëdron, and through the middle of the crystal, and one of the segments be turned a sixth part round, the form, Fig. 11., will be produced. The dotted lines in the first six Figures, shew the position of the nucleus or primitive crystal.

Topaz.

- Fig. 1.—A right rhomboidal prism with angles of $124^{\circ} 22'$ and $55^{\circ} 38'$.
Fig. 2.—An eight-sided prism terminated at each end by a four-sided pyramid.
Fig. 3.—A similar prism terminated at each end by two broad and four smaller planes.
Fig. 4.—A similar prism terminated at each end by two broad and five smaller planes.

Tourmaline.

- Fig. 1.—The primitive crystal, an obtuse rhomboid.
Fig. 2.—A nine-sided prism, terminated at one end by six planes, and at the other by three.
Fig. 3.—Shews the lower end of Fig. 2.
Fig. 4.—A nine-sided prism terminated at each end by six planes, the broader and narrower of which are set alternately on the edges and sides.
Fig. 5.—The lower end of Fig. 4.
The ends A A of Figs. 2. and 4. are the seats of the vitreous or positive, and B B of the resinous or negative electricity, when the crystals are gently heated.

THE END.

DIRECTIONS TO THE BINDER.

<i>View of Negroes washing for Diamonds at Mandanga on the River</i>	
<i>Jigitonhonba in Cerro do Frio,</i> - - - - -	to face the Title
<i>View of the Gold-washing at Jaragua near St. Paul's,</i> - - - - -	p. 78
<i>Map of the Author's Route,</i> - - - - -	p. 137
<i>View of the Topaz Mine at Capon</i> - - - - -	p. 163
<i>View of the Manner in which the Bed of the River Jigitonhonba is laid</i>	
<i>dry by an Aqueduct in order to search for Diamonds,-</i> - - - -	p. 221
<i>Machinery,</i> - - - - -	p. 276

The Three following at the End of the Appendix :

Crystals of Diamond, Topaz, and Tourmaline.
Minerals collected by the Author during his Tour.
Shells.

MINERALOGY.

THE study of this useful science has been much retarded by the difficulty of obtaining a Collection, and the high prices generally asked for peculiar Specimens. With a view to obviate this, Mr. MAWE has been induced to form Portable Collections, classed and arranged, with a Catalogue, at Twelve Guineas; larger Cabinets, containing two hundred and fifty Specimens, at Fifteen Guineas; others, containing upwards of three hundred Varieties, Twenty Guineas. Collections, consisting of five hundred larger and fine Specimens (without Cabinet) Fifty Guineas.

Any Specimens may be exchanged, if required; and the Collection may be formed peculiarly rich in any given Class.

Large, elegant and rare Minerals at reduced prices. Precious Stones, Minerals and Shells, purchased.

A great Variety of elegant Vases formed and enriched after the Antique.

At No. 149, Strand, Three Doors West from Somerset-house.

MODERN PUBLICATIONS,

AND

NEW EDITIONS OF VALUABLE STANDARD WORKS,

PRINTED FOR

LONGMAN, HURST, REES, ORME, AND BROWN, PATERNOSTER ROW.

Periodical Publications and Fine Arts.

THE NEW CYCLOPEDIA; or, UNIVERSAL DICTIONARY of Arts, Sciences, and Literature. Formed upon a more enlarged Plan of Arrangement than the Dictionary of Mr. Chambers; comprehending the various Articles of that Work, with Additions and Improvements; together with the new Subjects of Biography, Geography, and History; and adapted to the present State of Literature and Science.

By **ABRAHAM REES, D.D. F.R.S. F.L.S.** Editor of the last Edition of Mr. Chambers's Dictionary; with the Assistance of eminent professional Gentlemen, illustrated with new Plates, including Maps, engraved for the Work by some of the most distinguished Artists. Parts I. to XL. Price 20s. each in Boards, may be had either periodically or together.

* A few Copies are printed off on Royal Paper, with beautiful Impressions of the Plates. Price 1*l.* 16s. each Part.
** The Public are respectfully informed, that a Re-publication in Monthly Parts, at 20s. each, of the above Work, commenced this Day, and will be regularly continued on the First of every succeeding Month, till its Completion. Forty Parts (above Half of the Work) being already printed, they may be had together immediately if desired; and new Arrangements are made to publish in continuation Eight Parts within the Year, so as to complete the Work within a moderate Time.

This Publication, which is the most comprehensive of its kind, has been undertaken at an Expence of 200,000*l.* with a View of producing a Work worthy of the present improved State of Science and the Arts, and of the Nation. The Editor, whose Learning, Industry, and Experience, are generally acknowledged, has engaged professional Assistance every Department of Science; and the Work, from its varied Nature, will, in every Page, be found to be interesting and instructive to every Class of Readers. The Engravings form a prominent and most important Feature, consisting of a Series of Plates of General Science, Machinery, and Natural History, truly valuable from their Variety, Elegance, and Accuracy. The Scientific Subjects are engraved by Mr. Lowry, whose improved Method of execution and Truth of Drawing, have never been equalled. Mr. Lowry is indeed engaged, in that Department, exclusively for the present Work, which receives there and important Advantages from that able Artist's well-known scientific Attainments. The Subjects of Natural History are engraved by Mr. Milton and Mr. Scott, with the Taste for which those superior Artists are distinguished. The Drawings of Natural History are made by Mr. Donovan and Mr. Sydenham Edwards, and are of exquisite Beauty; they are now on Exhibition at No. 54, Bond Street; and it may be confidently said, that they form the most beautiful and interesting Collection of the Kind ever exhibited.

THOMSON'S SEASONS; illustrated with Engravings, by Bartolozzi and Tomkins, Historical Envoys to their Majesties, from original Pictures, painted the Work by W. HAMILTON, R.A. Imperial 4*to.* Price 4s. in Boards.

The same Book, with the Addition of Four large Engravings, by the same Artists, royal folio. Price 8*l.* 8s. in Boards. Ditto, super royal, with Proof Plates. Price 16*l.* 16s. Bds.
* A few Copies of the Imperial 4*to.* Edition may be had, with the Plates, finely coloured. Price 15*l.* 15s. in Bds.

A PICTURESQUE VOYAGE TO INDIA, the Way of CHINA.

By **THOMAS DANIELL, R.A.** and **WIL. DANIELL, A.R.A.** in Folio, with 50 Engravings, finely coloured and mounted with descriptive Letter-press to each, half-bound, Russia-ks. Price 12*l.*

Under the immediate Patronage of their MAJESTIES.

THE BRITISH GALLERY of PICTURES,

From the Old Masters.—In Two Series.—Published at the British Gallery, 54, New Bond Street.

TO THE PUBLIC.

The Arrangements for the Conduct of this Grand National Work being now completed, and numerous Specimens exhibited to public Inspection, the Proprietors confidently submit the Undertaking to general Patronage.

The **FIRST SERIES** of the Work commences with the Marquis of Stafford's magnificent Collection, and contains highly-finished Engravings of the several Pictures on a small Scale, with Remarks, by W. Y. Otley, Esq. F.S.A. forming a descriptive and illustrated Catalogue of that Gallery. This Series may be subscribed for either in plain Prints, price 10*s.* 6*d.*; or Proofs, on India Paper, price 1*l.* 1*s.*; or correctly coloured and mounted, price 2*l.* 12*s.* 6*d.* each Number. Six Numbers have already appeared; and several will be published in the Course of every Year, and the Whole be completed in about Fifty Numbers. Coloured Impressions being also kept in neat Frames for separate Sale, Amateurs will be enabled to possess, in a moderately sized room, a correct Representation, in Colours, of the Whole of the Marquis of Stafford's extensive and valuable Gallery of Pictures.

The **SECOND SERIES** will comprise, in a size calculated to transmit a favourable Representation of the Composition, Touch, and Character of the original Picture, Engravings from a Series of Specimens of the most admired Productions of the old Masters, selected from the different Galleries which are dispersed over the United Kingdom, accompanied with Descriptions, Historical and Critical, by Henry Tresham, Esq. R.A. These may be subscribed for either in plain Prints, price 10*s.* 6*d.*; or Proofs, on India Paper, price 1*l.* 1*s.* each Number; or finely executed in Colours, price as follows: No. I. Rubens, 6*l.* 6*s.* No. II. Andrea del Sarto, 12*l.* 12*s.* No. III. Raphael, 6*l.* 6*s.* No. IV. Giorgione, 6*l.* 6*s.* to Subscribers. An advance of Price is made to Non-subscribers for single Pictures. The coloured Impressions will be finished from the Copies in a new and superior Manner, rendering them equal to fine and highly-finished Paintings. Subscribers will be at Liberty to take a Selection only, if more agreeable; not more, however, than Three or Four Pictures can, it is expected, be published in each Year. Coloured Impressions may also be had in Frames. The Grandeur and Interest of this Portion of the Work can scarcely be too highly estimated, as none but the most valuable Pictures of each Master will be copied. A Set of them in Colours will comprise a more select and interesting Collection than can be formed, unless it were possible to collect the Originals of the same Paintings into one Grand National Gallery.

The Subscription Book is already honoured with the Names of the Whole of the Royal Family, the principal Nobility, and Patrons of the Fine Arts.

The highly finished Drawings and Specimens of the Work are on Exhibition as above, where Subscribers' Names are taken in. Admittance to Non-Subscribers One Shilling.

THE FINE ARTS OF THE ENGLISH SCHOOL, comprising a Series of highly-finished Engravings, from Painting, Sculpture, and Architecture, by the most eminent English Artists, each Subject accompanied by appropriate historical, descriptive, critical, or biographical Letter-press. Edited by JOHN BRITTON, F.A.S.

Vol. I. in large 4*to.* Price 6*l.* 10*s.*; and on Atlas 4*to.* Price 11*l.* in Boards.

* A few Copies, with Proof Impressions of the Plates, on India Paper. Price 15*l.* 15*s.*

THE GENUINE WORKS OF WILLIAM HOGARTH, (containing 160 Plates) illustrated with Biographical Anecdotes, a Chronological Catalogue and Commentary. By JOHN NICHOLS, F.S.A. Edinburgh and Perth; and the late GEORGE STEEVENS, Esq. F.R.S. and F.S.A. A new Edition, in 2 vols. 4to. demy. Price 10*l.* 10*s.* in Boards; or on royal Paper, with Proof Impressions, Price 21*l.* in Boards.

THE ARABIAN NIGHTS' ENTERTAINMENT, carefully revised and occasionally corrected from the Arabic; to which is added, a Selection of New Tales, now first translated from the Arabic Originals; also an Introduction and Notes, illustrative of the Religion, Manners, and Customs of the Mahomedans.

By JONATHAN SCOTT, LL.D. Oxford.

Late Oriental Professor at the Royal Military, and East India College, &c. &c. In 6 vols. post 8vo. Price 3*l.* 13*s.* 6*d.* in Boards; and 6 vols. demy 8vo. Price 5*l.* 5*s.* in Boards, finely printed and hot-pressed (embellished with fine Engravings from Paintings by Smirke); also in 6 vols. 18mo. without Plates. Price 1*l.* 16*s.* in Boards.

THE ADVENTURES OF GIL BLAS OF SANTILLANE; translated from the French of Le Sage.

By BENJAMIN HEATH MALKIN, Esq. M.A. F.S.A.

Embellished with 24 fine Engravings, after Pictures by Smirke. In 4 vols. 8vo. Price 6*l.* 6*s.*; and a few Copies in 4 vols. 4to. with Proof Impressions. Price 10*l.* 10*s.* in Boards.

*The same Work in the original French, with the same Embellishments, both in 4to. and 8vo. at the above Prices. This Edition is printed from Didot's revised Text, in a Style of equal Elegance with the Translation.

The Plates of the English and the French Editions in 8vo. are printed on French Paper, and the Proofs of the 4to. on India Paper.

A SERIES OF ENGRAVINGS to illustrate DANTE. Engraved by Pirolì of Rome, from Compositions by JOHN FLAXMAN, R.A. In the Possession of Thomas Hope, Esq.

This Work consists of 111 Plates, illustrative of the Inferno, Purgatorio, and Paradiso of Dante, with Descriptions in Italian, and the parallel Passages from Mr. Boyd's Translation. In folio. Price 4*l.* 4*s.* in Boards.

A SERIES OF ENGRAVINGS to illustrate the ILIAD and ODYSSEY of HOMER.

From the Compositions of JOHN FLAXMAN, R.A. Sculptor to the King. New Editions, with additional Plates. Price 2*l.* 2*s.* each.

These Works altogether consist of 75 Prints, representing in regular Succession the Stories of the Iliad and the Odyssey, with Descriptions of their Subjects, and Extracts from Pope's Translation upon each Plate. The Dresses, Habits, Armour, Implements of War, Furniture, &c. are all of Classical Authority.

THE ARCHITECTURAL ANTIQUITIES OF GREAT BRITAIN, displaying a Series of Select Engravings, representing the most beautiful, curious, and interesting ancient Edifices of this Country; with an Historical and descriptive Account of each Subject.

By JOHN BRITTON.

Parts I. to XXVIII. In Medium and Imperial 4to. 10*s.* 6*d.* and 16*s.* each (to be continued Quarterly.)

"The engravings are executed in a superior style; the descriptions are sufficiently ample, and appear to be accurate; and, under the superintendance of so able an antiquary as Mr. Britton, there can be no doubt that the succeeding parts will display a corresponding excellence." *Anti Jac.* "The plates are beautifully executed, and the whole constitutes a pleasing performance of a moderate price." *M. Rev.* "In the selection of specimens, Mr. Britton has unquestionably shown his judgment; a work so executed cannot fail to meet encouragement." *Brit. Crit.*

BALLANTYNE'S SHAKESPEARE, WITH ELEGANT VIGNETTE ENGRAVINGS.

THE PLAYS OF WILLIAM SHAKESPEARE, printed from the Text of Samuel Johnson, George Steevens, and Isaac Reed. Embellished with elegant Vignette Engravings, from Paintings by Howard, Smirke, Stothard, Thompson, Westall, &c. In 12 vols. 8vo. finely printed by Ballantyne of Edinburgh. Price 6*l.* 6*s.* in Boards; or on royal Paper, with Proof Impressions. Price 10*l.* 16*s.*

HINTS to YOUNG PRACTITIONERS in the Study of Landscape Painting. Illustrated with Ten Engravings, intended to show the different Stages of the Neutral Tint. To which are added, Instructions in the Art of Painting on Velvet. By J. W. ALSTON, L.P.

A new Edition. In 1 vol. 8vo. Price 7*s.* 6*d.* in Boards.

"This work contains plain and clear instructions for drawing Landscapes; also respecting the mixing and management of colours, &c." *Gen. Rev.*

RURAL SPORTS. By W. B. DANIEL. 3 vols. 4to. Price 7*l.* 17*s.* 6*d.*; and 3 vols. 8vo. Price 5*l.* 5*s.* in Boards. New Editions, embellished with 70 beautiful Engravings, by Scott, from Drawings by the most celebrated Artists.

THE SPORTSMAN'S CABINET; or, Correct Delineations of the various Dogs used in the Sports the Field; including the Canine Race in general. Consisting of a Series of rich and masterly Engravings of every distinct Breed, from original Paintings, taken from I. purposely for the Work. By P. REINAGLE, A.R.A. And elegantly engraved by Scott. In 3 vols. super-royal 4to. Price 7*l.* 7*s.* in Boards.

HOUSEHOLD FURNITURE, and INTERIOR DECORATION, executed from Designs, consist of Perspective and Geometrical Views of Apartments, with their Chairs, Tables, Sophas, Candelabra, Chandeliers, &c. &c. By THOMAS HOPE, Esq.

On royal folio. Price 5*l.* 5*s.* in extra Boards; or with Proof Impressions on Atlas Paper, price 10*l.* 10*s.*

ILLUSTRATIONS of the SCENERY KILLARNEY, the surrounding Country, and a considerable Part of the Southern Coast of Ireland.

By ISAAC WELD, Esq. M.R.I.A.

In one vol. 4to. with numerous Plates elegantly engraved Price 2*l.* 2*s.*; and on royal Paper, with first Impressions: the Plates, Price 3*l.* 3*s.* in extra Boards.

"In Mr. Weld this illustrious and beautiful scenery has been accurately and ably delineated. His pen and his pencil both been employed with effect, and we have seldom seen a work that combines more classical illustration with a high degree graphic excellence." *Quar. Rev.*

ESSAYS on the ANATOMY of EXPERIMENT in PAINTING. By CHARLES BELL.

Price 2*l.* 2*s.* in Boards.

"This is a very elegant and interesting publication." *Edin. J.*

NEW BRITISH ENCYCLOPEDIA; DICTIONARY OF ARTS AND SCIENCES, comprising accurate and popular View of the present improved State of Human Knowledge. By WILLIAM NICHOLSON, Author and Proprietor of the Philosophical Journal, various other Chemical, Philosophical, and Mathematical Works. Illustrated with 156 elegant Engravings, by Lo and Scott. Neatly printed by Whittingham. In 6 vols. 8vo. Price 6*l.* 6*s.* in Boards.

THE BRITISH THEATRE; or, a COLLECTION OF PLAYS, which are acted at the Thea Royal Drury-Lane, Covent-Garden, and Haymarket, prior under the Authority and by Permission of the Managers from the Prompt-Books, with Biographical and Critical marks. By Mrs. INCHBALD.

With elegant Engravings. In 25 vols. royal 18mo. Price 6*l.* 16*s.* 6*d.* in Boards; or on fine Paper, with Portraits Proof Impressions of the Plates. Price 13*l.* in Boards.

The following are the Plays contained in this Work which may be purchased separately. Price 1*s.* each:

1. Mountaineers; 2. Speed the Plough; 3. Wheel of fate; 4. Lovers' Vows; 5. Inkle and Yarico; 6. Isabella; 7. Wild Oats; 8. Douglas; 9. Stranger; 10. Country Crier; 11. Dramatist; 12. Hamlet; 13. Grecian Daughter; 14. The Body; 15. John Bull; 16. Tancred and Sigismunda; 17. in the Wrong; 18. Macbeth; 19. Bold Stroke for a Woman; 20. Poor Gentleman; 21. Such Things Are; 22. Oronook; 23. Love in a Village; 24. Road to Ruin; 25. Jane Shore; 26. Chasteline Marriage; 27. Edward the Black Prince; 28. Merry Wives of Windsor; 29. Rule a Wife and have a Wife; 30. Mourning Bride; 31. Cure for the Heart Ac; 32. All for Love; 33. Way to Keep Him; 34. King Job; 35. She Stoops to Conquer; 36. The Conscious Lover; 37. The Revenge; 38. Love for Love; 39. Every Man in Humour; 40. Coriolanus; 41. Jew; 42. Romeo and Juliet; 43. The Careless Husband; 44. George Barnwell; 45. Beau's Stratagem; 46. Gustavus Vasa; 47. The West Indian; 48. Julius Cæsar; 49. Every One has his Fault; 50. The Jealous Wife; 51. The Tempest; 52. The Orphan; 53. Cato; 54. The Belle's Stratagem; 55. Zara; 56. The Penitent; 57. The Deserted Daughter; 58. First Love; 59. Siege of Damascus; 60. Provoked Wife; 61. Rival Queens; 62. Lady Jane Grey; 63. Love makes a Man; 64. Rags; 65. Point of Honour; 66. Barbarossa; 67. Merchant of Venice; 68. Wives as they Were; 69. King Lear; 70. Constant Couple; 71. School of Reform; 72. To Marry or no Marry; 73. King Henry VIII.; 74. King Henry V.; 75. Cato; 76. Antony and Cleopatra; 77. Recruited Officer; 78. Countess of Salisbury; 79. Winter's Tale; 80. Montfort; 81. Count of Narbonne; 82. Castle of Andalus;

5. Suspicious Husband; 84. A Bold Stroke for a Husband; 5. A new Way to Pay old Debts; 86. Way to get Married; 7. Fatal Curiosity; 88. Earl of Warwick; 89. Fountain-eau; 90. The Honeymoon; 91. The Wonder; 92. Lionel el Clarissa; 93. Earl of Essex; 94. King Henry the Fourth, art I.; 95. The Brothers, a Comedy; 96. She Would and le Would Not; 97. The Inconstant; 98. The Rivals; 1. Measure for Measure; 100. Know your own Mind; 11. King Richard the Third; 102. King Henry the Fourth, art II.; 103. The Gamester; 104. The Man of the World; 5. Maid of the Mill; 106. The Duenna; 107. The Provok'd usband; 108. The Chances; 109. The Distressed Mother; 0. The Beggar's Opera; 111. Mahomet; 112. The Found- ing; 113. As You Like it; 114. Twelfth Night; 115. Much to about Nothing; 116. Cymbeline; 117. Venice Preserv- d; 118. Comedy of Errors; 119. Tamerlane; 120. Surren- r of Calais; 121. Battle of Hexham; 122. Iron Chest; 3. Heir at Law; 124. Othello; 125. Heiress.

THE MODERN THEATRE; or, a Collec- tion of successful MODERN PLAYS, acted at the Theatres yal, London. Printed from the Prompt-Books by Autho- y of the Managers. Selected by Mrs. INCHBALD

In 10 vols. royal 18mo. to correspond with Inchbald's itish Theatre, and Collection of Farces. Price 2*l.* 10*s.* in Boards. On fine Paper, do. 3*l.* 15*s.* in ards.

Contents of Vol. 1.—Will; Rage; Life; How to Grow h; Notoriety. Vol. 2.—Speculation; Delinquent; Laugh en you can; Fortune's Fool; Folly as it Flies. Vol. 3.— rter; Who wants a Guinea; Secrets worth Knowing; rinks; Votary of Wealth. Vol. 4.—Duplicity; School for 'ogance; He is much to blame; Seduction; School for justice. Vol. 5.—False Impressions; Mysterious Hus- id; Box Lobby Challenge; Natural Son; Carmelite. . 6.—Impostors; Wife of Two Husbands; Ramah Droop; y of Lombardy; Braganza. Vol. 7.—I'll tell you what; kt-door Neighbour; Wise Man of the East; Percy; Trip Scarborough. Vol. 8.—Mattida; Mary Queen of Scots; ritive; He would be a Soldier; England Preserved. . 9.—Bank Note; Chapter of Accidents; English Mer- nts; School for Wives; Henry the Second. Vol. 10.— hionable Levites; Time is a Tell-tale; Which is the ;; What is She; Lie of the Day.

A COLLECTION of FARCES, and other AFTERPIECES, which are acted at the Theatres Royal, Drury-Lane, Covent-Garden, and Haymarket. Printed un- der the Authority of the Managers from the Prompt-Book.

Selected by Mrs. INCHBALD
In 7 vols. royal 18mo. Price 1*l.* 15*s.* in Boards; or on fine Paper, with Portraits. Price 2*l.* 12*s.* 6*d.* in Boards.

The following are contained in this Work:
Child of Nature—Wedding Day—Midnight Hour—Rais- ing the Wind—Matrimony—Ella Rosenberg—Blind Boy— Who's the Dupe—Love a la Mode—Ratford Bridge—Netley Abbey—The Turnpike Gate—Lock and Key—The Register Office—The Apprentice—The Critic—The Sultan—Rosina— High Life below Stairs—Bon Ton—The Mock Doctor—The Devil to pay—The Irish Widow—The Minor—The Mayor of Garrat—The Liar—Flora—The Birth-day—The Jew and the Doctor—The Irishman in London—The Prisoner at Large— The Poor Soldier—The Farmer—The Highland Reel—Two Strings to your Bow—The Deserter—All the World's a Stage—Lying Valet—The Citizen—Three Weeks after Marriage— Catharine and Petruccio—Padlock—Miss in her Teens— The Quaker—The Guardian—The Deuce is in Him—Edgar and Emmeline—Richard Cœur de Lion—The Maid of the Oaks—Tom Thumb—The Doctor and the Apothecary—The First Floor—The Adopted Child—The Farm House—Lo- doiska—Ways and Means—The School for Authors—Midas —The Waterman—The Author—The Old Maid—The Miller of Mansfield—Comus.

THE EDINBURGH ANNUAL REGIS- TER, for 1808. In 2 thick demy 8vo. Volumes. Price 1*l.* 4*s.* in Boards.

DITTO, for 1809. Price 1*l.* 4*s.* in Boards.

THE BRITISH REVIEW, and LONDON CRITICAL JOURNAL. Parts I. to V. Price 6*s.* each (con- tinued Quarterly.)

THE AMERICAN REVIEW of History and Politics, and General Repository of Literature and State Papers. Three Parts, forming Vol. I. Price 18*s.* in Boards

Voyages, Travels, Geography, and Topography.

A COLLECTION of VOYAGES and TRA- VELS; forming a complete History of the Origin and Pro- cess of Discovery, by Sea and Land, from the earliest s to the present Time. Preceded by an Historical In- troduction, and critical Catalogue of Books of Voyages and yels, and illustrated and adorned with numerous En- gings.

By JOHN PINKERTON,
Author of "Modern Geography," &c.

he first Portion, comprising the Narratives of the Euro- n Travellers. In 6 vols. 4to. Price 13*l.* 13*s.* in Boards.
Second Portion, comprising Asia. In 4 vols. 4to. Price 3*s.* in Boards. The Third Portion, containing the Asiatic nds, Australasia, and Polynesia. In 1 vol. 4to. Price 12*s.* 6*d.* in Boards.

he Remainder of the Work, containing the Descriptions merica and Africa, will be published in similar detached ions, for the Accommodation of Persons who may prefer Mode of Publication.

MODERN GEOGRAPHY. A Description he Empires, Kingdoms, States, and Colonies; with the ans, Seas, and Isles, in all Parts of the World; includ- the most recent Discoveries and political Alterations. uted on a new Plan. By JOHN PINKERTON.

Astronomical Introduction by the Rev. S. Vince, A.M. S. and Plumian Professor of Astronomy, and Exper- tial Philosophy, in the University of Cambridge. With erous Maps, drawn under the Direction, and with the st Improvements of Arrowsmith, and engraved by Lowry. The Whole are added, a Catalogue of the best Maps and ks of Travels and Voyages, in all Languages; and an ole Index. A new Edition. In 2 vols. 4to. Price 5*l.* 5*s.* in Boards.

Mr. P. has presented us with a production, which we need e ashamed to own as of British growth, which is not a mere seller's job, but is the fruit of the persevering study of a man iters, and has been conducted on the principles and for the ncrement of science." *Mon. Rev.*

umb. I. to IX. (to be continued every Two Months) of A NEW MODERN ATLAS. By JOHN KERTON. The Maps are engraved in the Size called

Colombier, from Drawings executed under Mr. Pinkerton's Eye; with all the Advantages afforded by the latest Im- provements in Geographical Precision; and they exhibit the utmost Beauty the State of the Arts can admit. It is calculated that the Work will be completed in 20 Numbers, each containing Three Maps. Price One Guinea.

A GEOGRAPHICAL and HISTORICAL VIEW of the WORLD; exhibiting a complete Delineation of the natural and artificial Features of each Country; and a succinct Narrative of the Origin of the different Nations, their Political Revolutions, and Progress in Arts, Sciences, Literature, Commerce, &c. The Whole comprising all that is important in the Geography of the Globe and the History of Mankind.

By JOHN BIGLAND,
Author of "Letters on Ancient and Modern History, &c." In 5 large vols. 8vo. Price 3*l.* 13*s.* 6*d.* in Boards.

"In these volumes Mr. Bigland exhibits a very pleasing pic- ture of the past and the present state of mankind, of their pro- gress in civilization and arts, with portions of their topographi- cal, their civil and military history, so judiciously combined, as to constitute a very edifying and amusing work. It may be pe- rused with great advantage by juvenile students who wish for a general view of the present and the past state of man in all parts of the world, before they enter on the detailed investigation of particular portions of the globe; nor will it be unacceptable to those who are more advanced in life, and who wish to renew their former recollections, and to retrace the historical path which they have before trod." *Crit. Rev.*

A VIEW of SPAIN; comprising a descrip- tive Itinerary of each Province, and a general Statistical Account of the Country; including its Population, Agri- culture, Manufactures, Commerce, and Finances; its Go- vernment, Civil and Ecclesiastical Establishments; the State of the Arts, Sciences, and Literature; its Manners Customs, Natural History, &c.

By ALEXANDER DE LABORDE.
Translated from the French. In 5 vols. 8vo. with an Atlas of the Roads of Spain, and other Maps of the Country, &c. Price 3*l.* 13*s.* 6*d.* in Boards.

"More information concerning Spain is here brought together, than was perhaps ever collected into a single publication." *Mon. Rev.* "This publication contains a vast accumulation of important details, and is the most comprehensive and satisfactory work on the subject." *Ed. Rev.*

THE GEOGRAPHICAL, NATURAL, and CIVIL HISTORY of CHILI. Translated from the original Italian of the ABBE DON J. IGNATIUS MOLINA. To which are added, Notes from the Spanish and French Version, and Two Appendices, by the English Editor. In 2 vols. 8vo. with a Map of the Country. Price 18s. in Bds.

A VIEW of the ANCIENT and PRESENT STATE of the ZETLAND ISLANDS; including their Civil, Political, and Natural History, Antiquities, and an Account of their Agriculture, Fisheries, Commerce, and the State of Society and Manners.

By ARTHUR EDMONDSTON, M.D.

In 2 vols. 8vo. illustrated by a Map. Price 18s. in Boards.

"We have not often perused a more entertaining or well-written book of the kind, and accordingly recommend it as an entertaining and valuable addition to our geographical collections." *Brit. Crit.*

A DESCRIPTION of the FEROE ISLANDS, containing an Account of their Situation, Climate, and Productions; together with the Manners and Customs of the Inhabitants, their Trade, &c. Translated from the Danish. By the Rev. G. LANDT.

In 8vo. illustrated with a Map, and other Engravings. Price 12s. in Boards.

"This volume contains a very full and circumstantial description of the Feroe Islands, which appears to surpass all that have preceded it in copiousness and accuracy of details. Mr. Landt is evidently a man of learning, good sense, and just observation." *Crit. Rev.*

AN ACCOUNT of JAMAICA, and its INHABITANTS. By a GENTLEMAN,

long resident in the West Indies. In 8vo. Price 7s. 6d. Bds.

"The present work contains a great deal of useful information respecting Jamaica." *Mon. Rev.*

LETTERS from CANADA; written during a Residence there, in the Years 1806, 1807, 1808.

By HUGH GRAY.

In 8vo. with a Map. Price 12s. in Boards.

"These letters appear to be the result of much careful observation, and are written with great good sense. It is an entertaining, and must be a useful publication." *Brit. Crit.*

HISTORY of SUMATRA.

By WILLIAM MARSDEN, Esq. F.R.S.

The Third Edition, with Corrections and considerable Additions, in 1 vol. 4to. with an Atlas of Plates in Folio. Price 3l. 13s. 6d. in Boards.

NORTH WALES; including its Scenery, Antiquities, Customs, and some Sketches of its Natural History; delineated from Two Excursions through all the interesting Parts of that Country during the Summers of 1798 and 1801. By the Rev. W. BINGLEY, A.M.

In 2 vols. 8vo. Second Edit. illustrated with a new and accurate Map, Frontispieces, and several favourite Welsh Airs. Price 1l. 1s. in Boards.

"We have no hesitation in declaring that these volumes deserve to be ranked among the best performances of the kind; nor will any one hereafter act wisely, who should visit North Wales without making them his companion." *Brit. Crit.*

A TOPOGRAPHICAL DICTIONARY of ENGLAND; exhibiting the various Subdivisions of each County into Hundreds, Lathes, Wapentakes, &c. The Valuations in the King's Books; the Patrons of the Ecclesiastical Benefices; and the Tutelary Saint of each Church.—The Distance and Bearing of every Parish or Hamlet, from the nearest Post Office Town.—Markets.—Fairs.—Corporations.—Free Schools.—The Situation and Description of Monasteries, and other religious Houses.—Members of Parliament.—Assizes and Petty Sessions.—Collected from the most authentic Documents, and arranged in alphabetical Order. By NICHOLAS CARLISLE,

Fellow and Secretary of the Society of Antiquaries of London. In 2 thick vols. 4to. Price 5l. 5s. in Boards.

GLEANINGS through WALES, HOLLAND, and WESTPHALIA. By Mr. PRATT.

The Sixth Edition. In 3 vols. Price 1l. 4s. in Boards.

GLEANINGS in ENGLAND; descriptive of the Countenance, Mind, and Character of the Country. By Mr. PRATT.

In 3 vols. 8vo. Price 1l. 13s. in Boards.

POLITICAL ESSAY on the KINGDOM NEW SPAIN, containing Researches relative to the Geography of Mexico, the Extent of its Surface and its Political Division into Intendancies, the physical Aspect of Country, the Population, the State of Agriculture, manufacturing and commercial Industry, the Canals projected between the South Sea and the Atlantic Ocean, Crown Revenues, the Quantity of precious Metals which have flowed from Mexico into Europe and Asia since the Discovery of the new Continent, and the Military Def of New Spain. By Alexander De Humboldt; with physical Sections and Maps founded on Astronomical Observations and Trigonometrical and Barometrical Measurements Translated from the original French. By JOHN BLAKE.

In 4 vols. 8vo. Price 3l. 7s. 6d. in Boards.

Vol. III. and IV. may be had separate. Price 1l. 11s. 6d. "This is a work of more than ordinary value, whether we consider the interesting nature of its subject, or the high character and qualifications of its author. Mr. Humboldt has been long brated both for his enterprise as a traveller, and his attainments as a man of science, intimately acquainted with the country he professes to describe, and eminently qualified for the task of scrupling it; he has here presented us with an ample collection of valuable facts and observations." *Ectec. Rev.*

LETTERS written during a short Residence in SPAIN and PORTUGAL.

By ROBERT SOUTHEY.

In 2 vols. foolcap 8vo. A new Edition, corrected and amended. Price 10s. 6d. in Boards.

"These letters contain a large portion of information, communicated in a very agreeable and lively manner." *Mon. Rev.*

EXPLORATORY TRAVELS through WESTERN TERRITORIES of NORTH AMERICA;prising a Voyage from St. Louis, on the Mississippi, to Sources of that River, and a Journey through the Interior of Louisiana and the North-eastern Provinces of Spain. Performed in the Years 1805, 1806, 1807, by order of the Government of the United States.

By ZEBULON MONTGOMERY PIKE.

Major 6th Regt. U. S. Infantry. In 1 vol. 4to. with large Maps. Price 1l. 16s.

"This is a valuable work, from the information which it abounds relative to a part of the world which is so little known." *Crit. Rev.*

A HISTORICAL TOUR through PEMBROKESHIRE, comprising Accounts and Illustrations of all the Classes of Antiquity; also the Picturesque Scenery, Gentlemen's Seats, and various Objects of natural and artificial Curiosities within that interesting County.

By RICHARD FENTON, Esq. F.A.S.

In 1 vol. royal 4to. Price 6l. 6s.; and in demy 4to. 3l. 13s. 6d. embellished with 32 Engravings and a Map.

A JOURNEY through PERSIA, ARMENIA, ASIA MINOR, to CONSTANTINOPLE, in the Year and 1809, in which is included some Account of the proceedings of His Majesty's Mission under Sir Harford B. Bart. K.C. to the Court of the King of Persia.

By JAMES MORIER,

His Majesty's Secretary of Embassy to the Court of Persia.

In 1 vol. 4to. with 25 Engravings from the Designs of the Author, a Plate of Inscriptions, and Three Maps; One the Observations of Captain James Sutherland, and drawn by Mr. Morier and Major Rennell. Price 3l. 15s. in Boards.

*A few Copies with Proof Impressions of the Plate India Paper. Price 5l. 5s.

TRAVELS in the ISLAND of ICELAND, during the Summer of the Year 1810.

By SIR GEORGE STEUART MACKENZIE, Bart. Fellow of the Royal Society of Edinburgh, &c. &c.

In 1 vol. 4to. embellished with 2 Maps and 15 Figures, many finely coloured, and 15 Vignettes. Price 3l. 3s. 1d.

History and Biography.

HISTORICAL SKETCHES of the SOUTH of INDIA, in an Attempt to trace the History of Mysoor, from the Origin of the Hindoo Government of that State to the Extinction of the Mohammedan Dynasty in 1799; founded chiefly on Indian Authorities, collected by the

Author while officiating for several Years as Political Agent at the Court of Mysoor. In 2 vols.

By Lieut. Colonel MARK WILKS.

In 4to. with Maps. Vol. I. Price 2l. 2s. in Bds.—Yet in the Press.

HISTORY AND BIOGRAPHY.

We acknowledge, in the name of the public, considerable obligations to this military gentleman for the work now before us, which will contribute some degree of improvement to the state of knowledge in this country respecting India. He appears to have possessed considerable advantages in point of information, both by access to scarce and valuable manuscripts, and other important documents, to have had the power, in short, of ascertaining with sufficient accuracy for all practical purposes, the leading facts of the history of that part of India." *Eclat. Rev.*

SIR JOHN FROISSART'S CHRONICLES

ENGLAND, FRANCE, SPAIN, and the adjoining Countries, from the latter Part of the Reign of Edward II. to the death of Henry IV. Newly translated from the French originals, with Variations and Additions from many celebrated MSS. By THOMAS JOHNES, Esq. M. P.

to which is prefixed, a Life of the Author, an Essay on Works, a Criticism on his History, and a Dissertation on Poetry. The 3d Edit. In 12 vols. 8vo. Price 7l. 4s. Bds. Froissart is an historian consulted and cited by every writer who has written of the period in which he wrote; he is chief, if not the only authentic source of information we are possessed of with regard to one of the proudest and most striking periods of our national annals. The engravings from old illustrated MSS. which accompany the present portion of the work, are as useful as well as curious ornaments. As the authenticity of the sources from which they are taken cannot be doubted, they are valuable pictures of the costume of the times. We consider the translation of Froissart's Chronicles by Mr. Johnes as an undertaking of great importance, and even of high national interest." *Crit. Rev.*

MEMOIRS of JOHN LORD DE JOINVILLE, Grand Seneschal of Champagne, written by himself, containing a History of Part of the Life of Louis IX. of France, surnamed St. Louis, including an Account of his Expedition to Egypt, in the Year 1248.

Translated by THOMAS JOHNES, Esq. M. P. Handsomely printed in 2 vols. 4to. and illustrated with engravings. Price 4l. 4s. in Boards.

THE CHRONICLES of ENGUERRAND

MONSTRELET; containing an Account of the cruel Wars between the Houses of Orleans and Burgundy; of the Possession of Paris and Normandy by the English; their Expulsion thence, and of other memorable events that happened in the Kingdom of France as well as other Countries; a History of fair Example and of great utility to the French, beginning at the Year 1400, where that Sir John Froissart finishes, and ending at the Year 1467, continued by others to the Year 1516.

Translated by THOMAS JOHNES, Esq. M. P. In 12 vols. 8vo. with a 4to. vol. of Plates. Price 7l. 4s. in Boards. In 5 vols. 4to. Price 21l. in Boards.

* A few Copies may be had in folio, with coloured titles.

MEMOIRS of the LIFE of COLONEL

HUTCHINSON, Governor of Nottingham Castle and Town, representative of the County of Nottingham in the Long Parliament, and of the Town of Nottingham in the First Parliament of Charles II. &c. With original Anecdotes of many of the most distinguished of his Contemporaries, and summary Review of Public Affairs. Written by his daughter, Lucy, Daughter of Sir Allen Apsley, Lieutenant of the Tower, &c. Now first published from the original manuscript. By the Rev. JULIUS HUTCHINSON.

to which is prefixed, the Life of Mrs. Hutchinson, written by herself, a Fragment. Embellished with Two elegantly graved Portraits, and a View of Nottingham Castle. The Third Edition. In 2 vols. 8vo. Price 1l. 1s.

* A few Copies of the 4to. are remaining on large paper. Price 2l. 12s. 6d. in Boards.

The present volume forms a valuable addition to our records, and is justly entitled to stand by the side of those of Rushworth, Camden, and Ludlow." *Mon. Rev.* "We have not often met with any thing more interesting and curious than this volume." *in. Rev.*

NAVAL and MILITARY MEMOIRS of GREAT BRITAIN, from 1727 to 1783.

By ROBERT BEATSON, Esq. LL.D. The Second Edition, with a Continuation. In 6 vols. 8vo. Price 3l. 3s. in Boards.

A POLITICAL INDEX to the HISTORIES

of GREAT BRITAIN and IRELAND; or a complete Register of the Hereditary Honours, Public Offices, and Persons in Office, from the earliest Periods to the present Time.

By ROBERT BEATSON, LL.D.

The Third Edition, corrected and much enlarged. In 6 vols. 8vo. Price 1l. 11s. 6d. in Boards.

"The public are certainly obliged to the author for the comment and publication of so useful a work; a work produced at the expense of much time and great labour, and executed with great fidelity." *Mon. Rev.*

A CHRONOLOGICAL REGISTER of both Houses of the BRITISH PARLIAMENT, from the Union in 1708, to the Fourth Parliament of the United Kingdom of Great Britain and Ireland, in 1807.

By ROBERT BEATSON, LL.D. In 3 vols. 8vo. Price 1l. 11s. 6d. in Boards.

MISCELLANEOUS ANECDOTES, illustrative of the Manners and History of Europe, during the Reigns of Charles II. James II. William III. and Queen Anne.

By JAMES PELLER MALCOLM, F.S.A. In 8vo. Price 12s. in Boards.

LONDINIUM REDIVIVUM, or an ancient

History, and modern Description of LONDON, compiled from Parochial Records, Archives of various Foundations, the Harleian MSS. and other authentic Sources.

By JAMES PELLER MALCOLM, F.S.A. In Four Volumes, 4to. Price 7l. 7s. in Boards.

"This may indeed be considered as an original History of London. No subject at all connected with the undertaking seems to have escaped the author's notice. The work is full of biographical notices, curious anecdotes, local peculiarities, charters, preambles, &c. &c.; and what is not less deserving praise, the extracts from Registers are so various, that certificates may be obtained if necessary of upwards of a thousand eminent names, exclusive of inscriptions on monuments." *Brit. Crit.*

ANECDOTES of the MANNERS and CUSTOMS of LONDON during the 18th Century, including the Charities, Depravities, Dresses, and Amusements of the Citizens of London, during that Period, with a Review of the State of Society in 1807. To which is added, a Sketch of the Domestic and Ecclesiastical Architecture of the various Improvements in the Metropolis. Illustrated by 50 Engravings. By JAMES PELLER MALCOLM, F.S.A.

The 2d Edit. In 2 vols. 8vo. Price 1l. 10s. in Boards.

ANECDOTES of the MANNERS and CUSTOMS of LONDON, from the ROMAN INVASION to the Year 1700; including the Origin of British Society, Customs, and Manners. A general Sketch of the State of Religion, Superstition, Dresses, and Amusements of the Citizens of London, during that Period. To which are added, Illustrations of the Changes in our Language, Literary Customs, and gradual Improvement in Style and Versification, and various Particulars concerning public and private Libraries. By JAMES PELLER MALCOLM, F.S.A.

In 1 vol. 4to. with 18 Engravings. Price 3l. 3s. in Boards. Also in 3 vols. 8vo. Price 2l. 2s. in Boards.

MEMOIRS of the LIFE and ADMINISTRATION of Sir ROBERT WALPOLE, Earl of ORFORD, with original Correspondence and authentic Papers, never before published.

By the late Rev. WILLIAM COXE, M.A. F.R.S. F.A.S. Archdeacon of Wilts, and Rector of Bemerton.

In 3 vols. 4to. with a Portrait of Sir Robert Walpole. Price 5l. 5s. in Boards.

* Also an Edition in 3 vols. 8vo. Price 1l. 4s. Boards.

LIFE of HORATIO LORD WALPOLE.

By the late Rev. WILLIAM COXE, M.A. F.R.S. F.A.S. Archdeacon of Wilts, and Rector of Bemerton.

A new Edition. In 2 vols. 8vo. Price 1l. 12s.

LIVES of ANCIENT PHILOSOPHERS,

translated from the French of FENELON, with Notes, and a Life of the Author. By the Rev. JOHN CORMACK, M.A.

In 2 vols. foolscap 8vo. The Second Edition. Printed by Ballantyne. Price 12s. in Boards.

THE LIFE of FENELON, Archbishop of Cambray, Author of Telemachus, &c. In 1 vol. post 8vo. Price 7s. in Boards.

By the late Rev. WILLIAM COXE, M.A. F.R.S. F.A.S. Archdeacon of Wilts, and Rector of Bemerton.

A new Edition. In 2 vols. 8vo. Price 1l. 12s.

LIVES of ANCIENT PHILOSOPHERS,

translated from the French of FENELON, with Notes, and a Life of the Author. By the Rev. JOHN CORMACK, M.A.

In 2 vols. foolscap 8vo. The Second Edition. Printed by Ballantyne. Price 12s. in Boards.

THE LIFE of FENELON, Archbishop of Cambray, Author of Telemachus, &c. In 1 vol. post 8vo. Price 7s. in Boards.

By the late Rev. WILLIAM COXE, M.A. F.R.S. F.A.S. Archdeacon of Wilts, and Rector of Bemerton.

A new Edition. In 2 vols. 8vo. Price 1l. 12s.

THE HISTORY of the ANGLO SAXONS.

The First Volume, containing their History before their Invasion of Britain, and their subsequent History in England to the Norman Conquest, including the Life of Alfred, and the Account of the Seakings and Pirates of the North.—

The Second Volume, describing their Manners, Government, Laws, Poetry, Literature, Religion, and Language.

By SHARON TURNER, F.S.A. In 2 vols. 4to. Price 3l. 3s. in Boards. The Second Edition, corrected and enlarged, with an Introduction, on the History of Britain before the Arrival of the Romans.

"We regard Mr. Turner's work as a very valuable addition to our national histories; from numerous and recondite sources he has collected much that is interesting and curious, respecting both the manners and the events of the periods which he describes. There certainly was occasion for such a work, and the execution of it leaves no room to regret that it devolved on Mr. Turner." *Ecl. Rev.*

By SHARON TURNER, F.S.A. In 2 vols. 4to. Price 3l. 3s. in Boards. The Second Edition, corrected and enlarged, with an Introduction, on the History of Britain before the Arrival of the Romans.

"We regard Mr. Turner's work as a very valuable addition to our national histories; from numerous and recondite sources he has collected much that is interesting and curious, respecting both the manners and the events of the periods which he describes. There certainly was occasion for such a work, and the execution of it leaves no room to regret that it devolved on Mr. Turner." *Ecl. Rev.*

By SHARON TURNER, F.S.A. In 2 vols. 4to. Price 3l. 3s. in Boards. The Second Edition, corrected and enlarged, with an Introduction, on the History of Britain before the Arrival of the Romans.

"We regard Mr. Turner's work as a very valuable addition to our national histories; from numerous and recondite sources he has collected much that is interesting and curious, respecting both the manners and the events of the periods which he describes. There certainly was occasion for such a work, and the execution of it leaves no room to regret that it devolved on Mr. Turner." *Ecl. Rev.*

By SHARON TURNER, F.S.A. In 2 vols. 4to. Price 3l. 3s. in Boards. The Second Edition, corrected and enlarged, with an Introduction, on the History of Britain before the Arrival of the Romans.

"We regard Mr. Turner's work as a very valuable addition to our national histories; from numerous and recondite sources he has collected much that is interesting and curious, respecting both the manners and the events of the periods which he describes. There certainly was occasion for such a work, and the execution of it leaves no room to regret that it devolved on Mr. Turner." *Ecl. Rev.*

MEMOIRS of the LIFE of DAVID GAR- RICK, Esq. interspersed with Characters and Anecdotes of the Theatrical Contemporaries; the Whole forming a History of the Stage, which includes a Period of 36 Years.

By THOMAS DAVIES.

A new Edit. in 2 vols. crown 8vo. with copious Additions and Illustrations in the Form of Notes. With a Head of Garrick. Price 14s. in Boards.

A BIOGRAPHICAL PEERAGE of the EMPIRE of GREAT BRITAIN; in which are Memoirs and Characters of the most celebrated Persons of each Family.

Volumes I. II. and III. (containing the Peerage of England and Scotland,) with the Arms neatly engraven on Wood. Price 24s. in Boards.

In the Press, and in a State of considerable forwardness, Volume IV. containing the Peerage of Ireland.

COLLINS' PEERAGE of ENGLAND, with very considerable Alterations and Improvements, and brought down to the present Time.

By Sir SAMUEL EGERTON BRYDGES.

In 9 vols. 8vo.

ANECDOTES of the LIFE of the Right Hon. WILLIAM PITT, EARL of CHATHAM, and of the principal Events of his Time, with his Speeches in Parliament, from the Year 1736 to the Year 1778.

The 7th Edition. In 3 vols. 8vo. Price 14. 11s. 6d. Bds.

A Genuine and corrected REPORT of the SPEECHES of the late Right Honourable WILLIAM PITT, in the House of Commons, from his Entrance in Parliament in 1781 to the Close of the Session in 1805. The Second Edition. Dedicated, by Permission, to Lord Grenville, and aided by Communications from distinguished Members of both Houses of Parliament. Second Edition. In 3 vols. 8vo. Price 14. 11s. 6d. in Boards.

BIOGRAPHIE MODERNE; or, Lives of remarkable Characters who have distinguished themselves from the Commencement of the French Revolution to the present Time, in which all the Facts which concern them are related in the most impartial and authentic Manner.

PROM THE FRENCH.

In 3 vols. 8vo. Price 14. 11s. 6d. in Boards.

* * The Edinburgh Reviewers speak with confidence of the accuracy of this work, from their own knowledge of the sources of its information, and recommend it as highly interesting in various points of view, and presenting us with portraits of beings, whose names we still recal with sensations of astonishment and terror.

MEMOIRS of the Life, Writings, and Correspondence of the late Mr. WILLIAM SMELLIE, Printer, Secretary and Superintendent of Natural History to the Society of Scottish Antiquaries, F.R.S.; Author of the Philosophy of Natural History; Translator of the Works of Buffon, &c. &c.

By ROBERT KEIR, F.R.S. and F.A.S. Ed.

Embellished with an elegantly engraved Portrait of Mr. Smellie, a Fac Simile of his Hand-writing, and those of the Count de Buffon, Lord Kames, and Lord Hailes. In 2 vols. 8vo. Price 14. 7s. in Boards.

CHRONICLE of the CID, Rodrigo Diaz Bivar, the Campeador. Corrected by ROBERT SOUTHEY. In 4to. Price 14. 15s.

"This performance is certainly one of the most interesting productions of the Spanish mind. It gives a full-length picture Spain in those dark ages in which the costume of other countries is so indistinct and confused." *Ann. Rev.*

THE HISTORY of BRAZIL. Part First By ROBERT SOUTHEY. In 4to. Price 24. 2s. Bds.

THE HISTORY of SPAIN; from the latest Period to the Close of the Year 1809.

By JOHN BIGLAND.

In 2 vols. 8vo. Price 14. 4s. in Boards.

"The author has produced a pleasing and useful work. It is received as a welcome present, by such of our readers as be desirous of taking a glance at the scenes formerly acted the theatre of that eventful drama, which at present so strongly fixes the attention of the civilized world." *Eclat. Rev.*

THE HISTORY of EUROPE, from

Peace of 1763 to the present Time, exhibiting a View the Commotions in Holland and Brabant, the Wars betwixt Russia, Austria, the Ottoman Porte, and Sweden, the Abolition of the Kingdom of Poland, the Revolution in France, and the Wars which have proceeded from that extraordinary Event, with the recent Revolutions in Spain, Portugal, and Sweden. By JOHN BIGLAND.

In 2 vols. 8vo. Price 14. 4s. in Boards.

A HISTORY of the COLLEGES, HALLS and PUBLIC BUILDINGS attached to the University of Oxford, including the Lives of the Founders.

By ALEX. CHALMERS, F.S.A.

In 2 vols. demy 8vo. Price 14. 11s. 6d.; and on a royal paper, Price 24. 15s. in Boards. Illustrated by a series of Engravings.—A few Copies in 4to. with Impress of the Plates on India Paper. Price 64. 6s. in Boards.

"A fitter person to execute this task than Mr. Chalmers could perhaps have been found, long versed in every branch of inquiry relative to the history, biography, and antiquities, as he practised in the art of writing, of a discriminating mind cool judgment." *Brit. Crit.*

LETTERS of MADAME LA MARQUI

DU DEFFAND to the Hon. HORACE WALPOLE, afterwards Earl of Oxford, from the Year 1766 to the Year 1780. To which are added, Letters of Madame Du Deffand to Voltaire. Published from the Originals at Strawberry Hill. In 4 vols. 12mo. with a Portrait, &c. Price 24. 2s. Board.

"These volumes are valuable for a great variety of anecdotal relating to distinguished characters, principally of our country, and for the judgment passed on them by a person so highly accomplished, and endowed with such remarkable good sense, knowledge of the world, as Madame Du Deffand." *Mon. Rev.*

A HISTORY of IRELAND, from the earliest Accounts to the Accomplishment of the Union with Great Britain in 1801. By the Rev. JAMES GORDON

Rector of Killeegy in the Diocese of Ferns, and of Cnaway in the Diocese of Cork. In 2 vols. 8vo. Price 14. 11s. in Boards.

"The author has not derogated from the reputation which derived from his prior publication; since we discover in it the same clear discernment, the same sound judgment, the same strong good sense, the same manly sentiments, and the same fear integrity, and devotion to truth." *Mon. Rev.*

Medicine, Surgery, and Chemistry.

THE PHARMACOPEIA of the ROYAL COLLEGE of PHYSICIANS of LONDON. 1809. Translated into English; with Notes, &c. By R. POWELL, M.D. Fellow of the College, Physician to St. Bartholomew's and the Magdalen Hospitals. The Second Edition, revised and corrected. In 8vo. Price 10s. 6d. in Boards.

THE SURGICAL WORKS of JOHN ABERNETHY, F.R.S. &c. &c. Part I. On the Constitutional Origin, Treatment of Local Diseases, and on Aneurisms. Price 7s. in Bds.—Part 2. On Diseases resembling Syphilis, and on Diseases of the Urethra. Price 6s. in Bds.—Part 3. On Injuries of the Head, and Miscellaneous Subjects. Price 7s. in Bds.—Part 4. On Lumber Abscesses and Tumours. Price 6s. in Bds. The Whole may be had together, in 2 vols. 8vo. Price 14. 6s. in Bds.

THE PRINCIPLES of SURGERY; Volume the First. By JOHN BELL, Surgeon.

In one large vol. royal 4to. illustrated by 80 Engravings, many of them accurately coloured from Nature. Price 44. 4s.

THE PRINCIPLES of SURGERY; Volume the Second. In Two Parts, royal 4to. illustrated by a merous Engravings, 54. 5s.

Volume the Third. In roy 4to. illustrated with 37 Engravings. Price 24. 2s. Boards.

ENGRAVINGS of the BONES, MUSCLE and JOINTS, illustrating the First Volume of the Anatomy of the Human Body. By JOHN BELL, Surgeon.

In 4to. with about 200 Pages of explanatory Letter-press. The Third Edition. Price 14. 11s. 6d. in Boards.

LETTERS concerning the DISEASES

of the URETHRA. By CHARLES BELL.

In 8vo. Price 7s. 6d. in Boards.

A SYSTEM of OPERATIVE SURGERY founded on the Basis of ANATOMY.

By CHARLES BELL.

In 2 vols. royal 8vo. illustrated with Engravings. Price 14. 14s. Boards.

THE ANATOMY of the HUMAN BODY.

By JOHN and CHARLES BELL, Surgeons.

A new Edition, considerably improved, complete in 3 vols. 8vo. Price 2l. 8s. in Boards. Containing the Anatomy of the Bones, Muscles, and Joints; and of the Heart, Arteries, and Brain; descriptive of the Course of the Nerves, and the Anatomy of the Eye and Ear; the Anatomy of the viscera of the Abdomen, the Parts in the Male and Female Pelvis, and the Lymphatic System, with an Appendix, &c. &c. The Whole illustrated by numerous Engravings.

ENGRAVINGS of the ARTERIES, illustrating the Second Volume of the Anatomy of the Human Body, by JOHN BELL, Surgeon; and serving as an Introduction to the Surgery of the Arteries, by CHARLES BELL, Surgeon. Superbly printed in imperial 8vo. The Third Edition. Price 15s. in Boards.

"We have seen no work better calculated for giving clear ideas on this important branch of anatomy, and we strongly recommend it to our medical friends, as at once a very useful and highly ornamental addition to their libraries." *Mon. Rev.*

THE ANATOMY of the BRAIN; explained

in a Series of Engravings, beautifully coloured, with a dissertation on the Communication between the Ventricles of the Brain. By CHAS. BELL.

Fellow of the Royal College of Surgeons of Edinburgh. 1 royal 4to. Price 2l. 2s. in Boards.

"We have here a publication which reflects much credit on the author's anatomical knowledge, and on his skill as an artist. The plates are executed in a very superior style of correctness and elegance." *Mon. Rev.*

A SERIES of ENGRAVINGS, explaining

the Course of the NERVES. By CHARLES BELL. Fellow of the Royal College of Surgeons. On royal 4to. with Letter-press Descriptions. Price 1l. 1s. in Boards.

"These engravings are in the author's usual style of correctness and elegance, and they may therefore be regarded as a valuable addition to the medical library." *Mon. Rev.*

A SYSTEM of DISSECTIONS; explaining

the Anatomy of the Human Body; with the Manner of displaying the Parts, the distinguishing the Natural from the diseased Appearances, and pointing out to the Student the Objects most worthy his Attention, during a Course of Dissections. By CHARLES BELL.

The Third Edition. In 2 vols. foolcap. Price 12s. Boards.

A SYSTEM of DISSECTIONS; explaining

the Anatomy of the Human Body, the Manner of displaying the Parts, and their Varieties in Disease. By CHARLES BELL.

Illustrated with Engravings. The Second Edition. In folio. Price 3l. 3s. in Boards.

OBSERVATIONS on the HYDRARGYRIA;

or that vesicular Disease arising from the Exhibition of mercury. By the late Sir GEORGE ALLEY, M.D. M.R.I.A. Fellow of the Royal College of Physicians of Edinburgh. 11 vol. 4to. Price 14s. in Boards.

A TREATISE on TROPICAL DISEASES,

and MILITARY OPERATIONS, and on the CLIMATE of the EAST INDIES. By BENJAMIN MOSELEY, M.D. The 4th Edit. In 1 vol. 8vo. Price 12s. 6d. Boards.

MEDICINÆ PRAXEOS COMPENDIUM,

symptomata, Causas, Diagnosin, Prognosin, et Medendi Rationem, exhibens. Auctore E.G. CLARKE, M.D. Collegii Regalis Medicorum Londinensis, nec non exercitii Medico. ditto Quarta, Plurimum Aucta et Emendata. Price 5s. sewed.

THE PRINCIPLES of MIDWIFERY;

including the Diseases of Women and Children.

By JOHN BURNS,

Lecturer of Midwifery, and Member of the Faculty of Physicians and Surgeons, Glasgow. The Second Edition. In 8vo. Price 12s. in Boards.

POPULAR DIRECTIONS for the TREAT-

MENT of the DISEASES of WOMEN and CHILDREN.

By JOHN BURNS,

Lecturer on Midwifery, and Member of the Faculty of Physicians and Surgeons in Glasgow. In 8vo. Price 9s. Bds.

The object of this work is to give an outline of the different diseases incident to women and children, with instructions for their treatment, plain enough to be generally understood, yet not so minute as to perplex those readers or whom they are intended. Such information highly useful in preventing unnecessary apprehensions respecting symptoms by no means dangerous, and in giving timely aid when delay might be injurious or fatal.

OBSERVATIONS on ABORTION; con-

taining an Account of the Manner in which it takes place, the Causes which produce it, and the Method of preventing or treating it.

By JOHN BURNS,

Lecturer of Midwifery, and Member of the Faculty of Physicians and Surgeons in Glasgow. The 2d Edit. Price 5s.

"We have perused this volume with great satisfaction, and most strongly recommend it to the attention of all our medical readers." *An. Rev.*

MEDICINA NAUTICA; an Essay on the

Diseases of Seamen. By THOMAS TROTTER, M.D. Late Physician to His Majesty's Fleet, &c. In 3 vols. 8vo. Price 1l. 3s. in Boards.

A VIEW of the NERVOUS TEMPERA-

MENT; being a Practical Inquiry into the increasing Prevalence, Prevention, and Treatment of those Diseases, commonly called Nervous, Bilious, Stomach, and Liver Complaints; Indigestion, Low Spirits, Gout, &c.

By THOMAS TROTTER, M.D.

The 2d Edition. In 1 vol. 8vo. Price 7s. 6d. in Boards.

An ESSAY, Medical, Philosophical, and Chie-

mical, on DRUNKENNESS, and its Effects on the Human Body.

By THOMAS TROTTER, M.D.

The 4th Edition. In 1 vol. 8vo. Price 6s. in Boards.

CONVERSATIONS on CHEMISTRY. In

which the Elements of that Science are familiarly explained and illustrated by Experiments. In 2 vols. 12mo. with Plates by Lowry. The 3d Edition. Price 14s. Boards.

"This work may be strongly recommended to young students of both sexes. The perspicuity of the style, the regular disposition of the subject, the judicious selection of illustrative experiments, and the elegance of the plates, are so well adapted to the capacity of beginners, and especially of those who do not wish to dive deep into the science, that a more appropriate publication can hardly be desired." *Brit. Crit.*

A SHORT SYSTEM of COMPARATIVE

ANATOMY, translated from the German of J. F. Blumenbach, Professor of Medicine in the University of Gottingen. With numerous additional Notes, and an Introductory View of the Classification of Animals.

By WILLIAM LAWRENCE,

Fellow of the Royal College of Surgeons in London, and Demonstrator of Anatomy of St. Bartholomew's Hospital. In one vol. 8vo. Price 12s. in Boards.

THE MEDICAL GUIDE, for the Use of

Families and Young Practitioners, or Students in Medicine and Surgery; being a complete System of modern and domestic Medicine; exhibiting in familiar Terms the latest and most important Discoveries relative to the Prevention, Distinction, Causes, and Cure of Diseases by Medicine and Diet, particularly Consumption of the Lungs, Asthma, Indigestion, Flatulence, Gout, Scrofula, Palsy, Rheumatism, Cancer, Worms, Nervous and Bilious Complaints, the Diseases of Children, &c. &c. To which are added, a Family Dispensatory and a Copious Appendix, containing explicit instructions for the ordinary Management of Children, and such Cases or Accidents which require immediate Aid, &c.

By RICHARD REECE, M.D.

Fellow of the Royal College of Surgeons, Author of a Treatise on the Lichen Islandicus, in Diseases of the Lungs, &c. The Eighth Edition, considerably enlarged and corrected. In one vol. 8vo. Price 10s. 6d. in Boards.

"It is of importance that every man should be enabled to know something of the laws of life, the nature of diseases, and the most rational modes of cure. For this purpose Dr. Reece's book is better adapted than any with which we are acquainted; it is more scientific and judicious than the domestic medicine of Buchan, which we have no doubt it will soon entirely supersede." *Cr. Rev.*

A PRACTICAL DICTIONARY of DO-

MESTIC MEDICINE, for the special Use of the Clergy, Heads of Families, and young Practitioners in Medicine. This Work exhibits a comprehensive View of the latest Discoveries relative to the Causes, Treatment, and Prevention of Diseases, and a popular Description of the following Subjects, so far as they regard the Health of Man, the well-being of Society, and the general Cure of Maladies, viz Anatomy, Casualties, Chemistry, Clothing, Diets, Medical Police and Jurisprudence, Pharmacy, Physiology, Surgery, Midwifery, Therapeutics, &c. &c.

By RICHARD REECE, M.D.

Member of the Royal College of Surgeons in London, Author of the Domestic Medical Guide, &c. &c. In one large vol royal 8vo. Price 18s. in Boards.

MEDICO-CHIRURGICAL TRANSACTIONS.

Published by the Medical and Chirurgical Society of London. In 8vo. illustrated with Ten Plates. Vol. I. Price 14s. in Boards.

The Second Volume. In 8vo. illustrated with Eight Plates. Price 16s. in Boards.

THE LONDON DISPENSATORY, containing the Elements and Practice of Materia Medica and Pharmacy, with a Translation of the Pharmacopœias of the London, the Edinburgh, and the Dublin Colleges of Physicians; many useful Tables; and Copper-plates of the Pharmaceutical Apparatus. The Whole forming a Synopsis of Materia Medica and Therapeutics.

By ANTHONY TODD THOMSON, Surgeon, Fellow of the Medical Society of London, and of the Royal Medical, the Physical, and the Speculative Societies of Edinburgh. In 8vo. Price 16s. in Boards.

LECTURES on DIET and REGIMEN; being a systematic Inquiry into the most rational Means of preserving Health, and prolonging Life; together with Physiological and Chemical Explanations, calculated chiefly for the Use of Families, in order to banish the prevailing Abuses and Prejudices in Medicine.

By A. F. M. WILLICH, M.D.

In one large vol. 8vo. The Fourth Edition, enlarged and improved. Price 9s. in Boards.

"We have said enough to evince that the writer has fulfilled all his promises; and, on the whole, has given by far the fullest, most perfect, and comprehensive dietetic system which has yet appeared." *Crit. Rev.* "This work is not only a valuable accession to medical science, but must prove an inestimable accommodation both to families and individuals situated at a distance from regular advice." *New London Rev.*

A SYSTEM of MATERIA MEDICA and PHARMACY. By JOHN MURRAY, Lecturer on Chemistry, and on Materia Medica and Pharmacy, Edinburgh. In 2 vols. 8vo. Price 1l. 1s. Boards.

THE ELEMENTS of CHEMISTRY.

By THOMAS THOMSON, M.D. F.R.S.
In 8vo. Price 10s. 6d. Boards.

A TREATISE on some practical Points relating to DISEASES of the EYE.

By the late JOHN CUNNINGHAM SAUNDERS, Demonstrator of Anatomy at St. Thomas's Hospital, Founder and Surgeon of the London Infirmary for curing Diseases of the Eye. To which is added, a short Account of the Author's Life, and his Method of curing the Congenital Cataract: By his Friend and Colleague, I. R. FARRE, M.D.

In royal 8vo. illustrated with 8 Engravings, and a Portrait of the Author. Price 21s. plain, and 1l. 11s. 6d. clothed.

THE MORBID ANATOMY of the Human Gullet, Stomach, and Intestines.

By ALEXANDER MONRO, Jun. M.D. F.R.S.E. Professor of Medicine, Anatomy, and Surgery, in the University of Edinburgh, Fellow of the Royal College of Physicians, &c. &c. &c. In one large vol. royal 8vo. illustrated by 20 Engravings. Price 1l. 18s. in Boards.

AN INQUIRY into the PROCESS of NATURE in repairing Injuries of the Intestines; illustrating the Treatment of Penetrating Wounds and Strangulate Hernia.

By BENJAMIN TRAVERS, Demonstrator of Anatomy at Guy's Hospital, Surgeon to the Hon. East India Company, and to the London Infirmary for Diseases of the Eye.

In one vol. 8vo. with Engravings by Stewart. Price 15s. in Boards.

Divinity.

PRACTICAL SERMONS. By ABRAHAM REES, D.D. F.R.S. F.L.S. Editor of the New Cyclopædia. The 2d Edition. In 2 vols. 8vo. Price 1l. 1s. in Boards.

THE RELIGIOUS WORLD DISPLAYED; or, a View of the Four Grand Systems of Religion; Judaism, Paganism, Christianity, and Mohammedism, and of the various existing Denominations, Sects, and Parties in the Christian World. To which is subjoined, a View of Deism and Atheism. By the Rev. ROBERT ADAM, B.A. Oxford, Minister of the Episcopal Congregation, Blackfriar's Wynd, Edinburgh; and Chaplain to the Right Hon. the Earl of Kellie. In 3 vols. 8vo. Price 1l. 11s. 6d. in Boards.

A New Literal TRANSLATION from the Original Greek of the APOSTOLICAL EPISTLES, with a Commentary, and Notes Philological, Critical, Explanatory, and Practical. To which is added, a History of the Life of the Apostle Paul. By JAMES MACKNIGHT, D.D.

In 4 vols. 8vo. Price 2l. 2s. in Boards. The 4th Edition. To which is prefixed, an Account of the Life of the Author. *A few Copies are remaining, with the Greek. In 6 vols. 8vo. Price 3l. 13s. 6d.

A HARMONY of the FOUR GOSPELS; in which the natural Order of each is preserved. With a Paraphrase and Notes. By JAMES MACKNIGHT, D.D. In 2 vols. 8vo. The 4th Edit. Price 1l. 1s. in Boards.

DISCOURSES on various SUBJECTS. By JER. TAYLOR, D.D. Chaplain in Ordinary to King Charles the First, and late Lord Bishop of Down and Connor. A new Edition. In 3 vols. 8vo. Price 1l. 7s. in Boards.

THE LIFE and DEATH of the ever blessed JESUS CHRIST, the Saviour of the World, with Considerations and Discourses upon the several Parts and Prayers fitted to the several Mysteries.

By JEREMY TAYLOR, D.D.

Chaplain in Ordinary to King Charles the Second.

In 2 vols. 8vo. Price 1l. 4s. in Boards.

THE RULE and EXERCISES of HOLY LIVING, in which are described the Means and Instruments of obtaining every Virtue, and the Remedies against every Vice, and Considerations serving to the resisting all Temptations; together with Prayers, containing the whole Duty of a Christian, and the Parts of Devotion fitted for all Occasions, and furnished for all Necessities.

By JEREMY TAYLOR, D.D.

And edited by the Rev. Thomas Thirlwall, M.A. The 28th Edition. In one vol. 8vo. Price 7s. in Boards.

THE RULE and EXERCISES of HOLY DYING.

By JER. TAYLOR, D.D.

The 27th Edition. Price 7s.

THE POWER of RELIGION on the MIND in Retirement, Affliction, and at the Approach of Death; Exemplified in the Testimonies and Experience of Persons distinguished by their Greatness, Learning, or Virtue.

By LINDLEY MURRAY.

The 15th Edition, corrected, and greatly enlarged. 1 8vo. Price 12s.

"It is a book which may be read with profit, by persons in a situations; and, with the rising generation, it may answer the double purpose of improving them in biography and in virtue." *M. Rev.*

Also the same Work in 12mo. Price 4s. 6d. in Boards.

SERMONS on several SUBJECTS. By the late Rev. WILLIAM PALEY, D.D. Subdean of Lincoln Prebendary of St. Paul's, and Rector of Bishop Wearnout's. Author of "Natural Theology, Moral Philosophy," &c. &c. In one vol. 8vo. The 5th Edition. Price 10s. 6d. in Boards.

LECTURES delivered in the Parish Church of Wakefield, in the Year 1802, on that Part of the Liturgy of the Church of England contained in the Morning Prayer.

By THOMAS ROGERS, M.A.

Master of the Grammar School, Afternoon Lecturer of St. John's, and Sunday Evening Lecturer of the Parish Church in Wakefield. In 4 vols. crown 8vo. Price 1l. 4s. Boards.

A PORTRAITURE of QUAKERISM, as taken from a View of the Moral Education, Discipline, peculiar Customs, Religious Principles, Political and Civil Economy, and Character of the SOCIETY of FRIENDS.

By THOMAS CLARKSON, M.A.

Author of several Essays on the Subject of the Slave Trade. The Third Edition. In 3 vols. 8vo. Price 1l. 7s.

"This book is to be considered as a faithful portraiture of the life of the most remarkable people existing among us. Its publication will form as great an era in the history of the society as that of their famous Apology." *Ann. Rev.*

POPULAR EVIDENCES of NATURAL RELIGION and CHRISTIANITY.

By the Rev. THOMAS WATSON.

In one vol. 12mo. A new Edition. Price 9s. in Boards. "The work contains multum in parvo, is singularly calculated to answer the object which it has in view; and as a popular and attractive antidote to infidelity, may be recommended to the various book societies scattered throughout the empire." *Non-Rep.*

CERTAIN PRINCIPLES in EVANSON'S

“**DISSONANCE of the FOUR EVANGELISTS.**” &c. examined in Eight Discourses, delivered before the University of Oxford, at St. Mary's, in the Year 1810, at the Lecture founded by the late Rev. John Bampton, Canon of Salisbury.

By THOMAS FALCONER, A.M.

Of Corpus Christi College, Oxford. In one vol. 8vo. Price 10s. 6d. in Boards.

HISTORY of the REFORMATION in

Scotland, with an Introductory Book, and an Appendix.

By GEORGE COOK, D.D.

Minister of Laurencekirk, and Author of “An Illustration of the General Evidence establishing the Reality of Christ's Resurrection.”

In 3 vols. 8vo. Price 1l. 11s. 6d. in Boards.

RURAL PHILOSOPHY; or, Reflections on

Knowledge, Virtue, and Happiness; chiefly in reference to a Life of Retirement in the Country.

By ELY BATES, Esq.

The 6th Edition. In 8vo. Price 9s. in Boards.

“To those who are of a serious and religious turn of mind, these reflections will prove a grateful and valuable acquisition. We recommend to them an attentive perusal of this well written and truly commendable volume.” *Mon. Rev.*

THE HOLY BIBLE, containing the Old and New Testaments, and Apocrypha, with Critical, Philological, and Explanatory Notes, and One Hundred and Twenty superior Copper-plates, engraved by the first Artists from the most admired Productions of the great Masters of the various Schools of Painting.

The Notes by the Rev. JOHN HEWLETT, B.D.

Morning Preacher at the Founding Hospital, &c. &c. On royal Paper, 4to. in 31 Parts, price 13l. 19s.; on fine demy Paper, price 10l. 17s.; and on fine demy Paper, without Plates, price 7l. 15s.; forming Three thick Volumes.

THE FAMILY EXPOSITOR; or, a Paraphrase and Version of the New Testament; with Critical Notes, and a Practical Improvement of each Section.

By P. DODDRIDGE, D.D.

To which is prefixed, a Life of the Author,

By ANDREW KIPPIS, D.D. F.R.S. and S.A.

The 10th Edit. In 6 vols. 8vo. Price 3l. 3s. in Boards.

ILLUSTRATIONS of the FOUR GOSPELS, founded on Circumstances peculiar to our Lord and the Evangelists.

By JOHN JONES.

In one large vol. 8vo. Price 15s. in Boards.

Education.

An ENGLISH GRAMMAR; comprehending the PRINCIPLES and RULES of the LANGUAGE, illustrated by appropriate EXERCISES, and a KEY to the EXERCISES.

By LINDLEY MURRAY. In Two Vols. 8vo. The Second Edition. Price One Guinea, in Boards.

“We have had no grammarian, within the compass of our critical career, who has employed so much labour and judgment upon our native language, as the author of these volumes. We are of opinion, that this edition of Mr. Murray's works on English Grammar, deserves a place in Libraries, and will not fail to obtain it.” *Brit. Crit.* “We have read this work with sufficient care, to be able to pronounce upon it, as a work of great correctness and perfection. We cannot dismiss these volumes without observing, that as they are intended for the higher classes of readers, they will be found particularly serviceable to instructors, to young persons who have left school, and to foreigners.” *Chr. Ob.* “Mr. Murray's English Grammar and Exercises have long maintained their reputation, as the works best adapted for the initiation of students in the principles of the English language. They are now united in an improved edition, printed with a large letter, and on a finer paper, in a form suited to the Library. The additions, it is stated, occupy more than ninety pages of the first volume; and are interspersed throughout the book. The whole well deserves the careful perusal of every student of our language; containing a copious and skilful analysis of its principles, and many just and acute remarks on the peculiarities of its idiom and construction.” *Ann. Rev.*

AN ENGLISH SPELLING BOOK; with

Reading Lessons adapted to the Capacities of Children. In Three Parts; calculated to advance the Learners by natural and easy Gradations; and to teach Orthography and Pronunciation together. By LINDLEY MURRAY.

In demy 18mo. The 12th Edit. Price 1s. 6d. bound.

“We recommend to the public this most important little volume, as the only work with which we are acquainted, in the English language, for teaching children to read, written by a philosopher and a man of taste.” *Lit. Journ.* “We can recommend it as the best work of the kind which has lately fallen under our inspection.” *Anti Jac.* “In this book are several useful things, not commonly found in such works.” *Brit. Crit.* “This little book is singularly well adapted to answer the purpose for which it is intended.” *M. Rev.* “Mr. Murray has composed one of the best elementary books for children in the English language.” *Crit. Rev.* “This is a very neat and useful elementary book.” *Chr. Ob.*

FIRST BOOK FOR CHILDREN.

By LINDLEY MURRAY.

The Sixth Edition. Price 6d. sewed.

“This very improved Primer is intended to prepare the learner for the above-mentioned Spelling Book, and is particularly intended by the author to assist mothers in the instruction of their young children.” *M. Rev.*

A KEY to the ENGLISH EXERCISES;

calculated to enable private Learners to become their own Instructors in Grammar and Composition. Price 2s. 6d. bound. The 11th Edition. The Exercises and Key may be had together. Price 4s. 6d.

“Mr. Murray's English Grammar, English Exercises, and Abridgment of the Grammar, claim our attention, on account of their being composed on the principle we have so frequently recommended, of combining religious and moral improvement with the elements of scientific knowledge. The late learned Dr. Blair gave his opinion of it in the following terms:—“Mr. Lindley Murray's Grammar, with the Exercises and the Key in a separate volume, I esteem as a most excellent performance. I think it superior to any work of that nature we have yet had; and am persuaded that it is, by much, the best Grammar of the English language extant. On Syntax, in particular, he has shown a wonderful degree of acuteness and precision, in ascertaining the propriety of language, and in rectifying the numberless errors which writers are apt to commit. Most useful these books must certainly be to all who are applying themselves to the arts of composition.” *Guard. of Educ.*

ENGLISH GRAMMAR, adapted to the different Classes of Learners. With an Appendix, containing Rules and Observations, for assisting the more advanced Students to write with Perspicuity and Accuracy.

By LINDLEY MURRAY. 21st Edit. Price 4s bound.

AN ABRIDGMENT of MURRAY'S ENGLISH GRAMMAR. With an Appendix, containing Exercises in Parsing, in Orthography, in Syntax, and in Punctuation. Designed for the younger Classes of Learners. The 33d Edition. Price 1s. bound.

ENGLISH EXERCISES, adapted to MURRAY'S ENGLISH GRAMMAR, consisting of Exemplifications of the Parts of Speech, Instances of False Orthography, Violations of the Rules of Syntax, Defects in Punctuation, and Violation of the Rules respecting Perspicuity and Accuracy. Designed for the Benefit of Private Learners, as well as for the Use of Schools. The 15th Edit. Price 2s. 6d.

INTRODUCTION to the ENGLISH READER; or, a Selection of Pieces, in Prose and Poetry, &c.

By LINDLEY MURRAY.

The Ninth Edition. Price 3s. bound.

“This introduction may be safely recommended, and put into the hands of youth: and the rules and observations for assisting them to read with propriety, form to it a very suitable introduction.” *M. Rev.*

THE ENGLISH READER; or, Pieces in Prose and Poetry, selected from the best Writers. Designed to assist young Persons to read with Propriety and Effect; to improve their Language and Sentiments; and to inculcate some of the most important Principles of Piety and Virtue. With a few preliminary Observations on the Principles of good Reading.

By LINDLEY MURRAY.

The Tenth Edition. Price 4s. 6d. bound.

“The selections are made with good taste, and with a view to moral and religious improvement, as well as mere entertainment.” *Brit. Crit.*

SEQUEL to the ENGLISH READER, or, Elegant Selections, in Prose and Poetry. Designed to improve the higher Class of Learners in Reading; to esta-

lish a Taste for just and accurate Composition; and to promote the Interest of Piety and Virtue.

By LINDLEY MURRAY.

The Third Edition. Price 4s. 6d. bound.

"We have no hesitation in recommending this selection as the best of its kind." *Cr. Rev.*

LECTEUR FRANCOIS; ou, Recueil de Pieces, en Prose et en Verse, tires des Meilleurs Ecrivains, pour servir a perfectionner les jeunes Gens dans la Lecture; a etendre leur Connoissance de la Langue Francoise; et a leur inculquer des Principes de Vertu et de Piete.

Par LINDLEY MURRAY.

The Second Edition. Price 4s. 6d. bound.

"Especial care has been taken to render the study of eloquence subservient to virtue, and to introduce only such pieces as shall answer the double purpose of promoting good principles, and a correct and elegant taste. This will, no doubt, be found a very useful school-book." *M. Rev.* "The student will find his advantage in making use of this work, as he will be sure to form his taste after the most correct models." *Crit. Rev.*

INTRODUCTION AU LECTEUR FRANCOIS; ou, Recueil de Pieces choisies; avec l'Explication des Idiotismes, et des Phrases difficiles qui s'y trouvent.

Par LINDLEY MURRAY.

In 12mo. Price 3s. 6d. in Boards.

"Mr. Murray has exercised his usual caution and judgment in these selections." *Anti Jac.* "Not a sentiment has been admitted which can hurt the most delicate mind; and, in many of the pieces, piety and virtue are placed in the most amiable and attractive points of view." *Cent. Mag.*

A SELECTION from Bishop HORNE'S COMMENTARY on the PSALMS.

By LINDLEY MURRAY,

Author of an English Grammar, &c. &c. In 1 vol. 12mo. Price 5s. in Boards.

"* * * This Selection is adapted to Readers who wish to cultivate a serious and pious Temper of Mind; and is particularly calculated to cherish, in the Minds of Youth, Sentiments of Love and Gratitude towards the Author of their being. For Persons who have not much Leisure for reading, and for the higher Classes in Schools occasionally, the Work is especially designed: and for this Purpose it is further recommended, by the Purity and Elegance of its Language, the Correctness and Excellence of its Composition.

GRAMMATICAL QUESTIONS, adapted to the Grammar of LINDLEY MURRAY, with Notes.

By C. BRADLEY, A.M.

Price 2s. 6d. bound. The 2d Edit. considerably improved.

AN ABRIDGMENT of Mr. PINKERTON'S MODERN GEOGRAPHY; and Professor VINCE'S ASTRONOMICAL INTRODUCTION. In one large vol. 8vo. with a Selection of the most useful Maps, accurately copied from those in the larger Work, all which were drawn under the Direction and with the latest Improvements of Arrowsmith. The 4th Edition. Price 18s. bound.

AN INTRODUCTION to Mr. PINKERTON'S ABRIDGMENT of his MODERN GEOGRAPHY, for the Use of Schools, accompanied with Twenty outline Maps, adapted to this Introduction, and suited to other Geographical Works, forming a complete Juvenile Atlas.

By JOHN WILLIAMS.

In one vol. 12mo. Price 4s. bound; and with the Atlas, consisting of 20 Maps. Price 8s. 6d. The Atlas separate Price 4s. 6d.

"Mr. Williams has executed his undertaking with great judgment and ability; and we cordially recommend his work as one of the best adapted to its object of any that have come under our inspection. The outline map, designed to accompany this introduction, will be found of great service." *An. Rev.*

PINKERTON'S SCHOOL ATLAS, containing 21 Maps, neatly coloured. Price 12s. half bound.

THE SCHOLAR'S SPELLING ASSISTANT. Intended for the Use of Schools and private Tuition.

By THOMAS CARPENTER,

Master of the Academy, Ilford, Essex. The Tenth Edition, corrected and improved. Price 1s. 3d. bound.

THE YOUTH'S GUIDE to BUSINESS; containing an easy and familiar Introduction to Book-keeping by Single Entry, Bills of Parcels, &c. Tables of Money, Weights, and Measures, methodised and arranged on an improved Plan; and a Variety of Arithmetical Questions for occasional Exercise and Improvement. Designed for the Use of Schools.

By THOMAS CARPENTER. Price 2s. 6d. bound.

AN INTRODUCTION to the GEOGRAPHY of the NEW TESTAMENT; comprising a Summary Chronological and Geographical view of the Events recorded respecting the Ministry of Our Saviour; with Questions for Examination, and an accented Index; principally designed for the Use of Young Persons, and for the Sunday Employment of Schools. By LANT CARPENTER, LL.D.

In one vol. 12mo. illustrated with Maps. The 3d Edition. Price 5s. in Boards.

"We recommend this book to all such as are anxious to obtain accuracy and precision in their geographical and chronological knowledge, as far as relates to the History of the Events recorded in the writings of the New Testament." *Lit. Jour.*

THE NEW ORTHOGRAPHICAL ASSISTANT; or, ENGLISH EXERCISE BOOK. Written on an improved Plan, for the more speedy Instruction of Young Persons in the Art of Spelling and Pronunciation, intended for the Use of Schools. By THOMAS CARPENTER.

Price 2s. bound.

PITY'S GIFT; a Collection of interesting Tales. From the Works of Mr. PRATT. In one vol. 12mo embellished with Wood Cuts. The 3d Edit. Price 3s. bound.

THE PATERNAL PRESENT; being a Sequel to Pity's Gift. Chiefly selected from the Writings of Mr. Pratt. The 2d Edit. With 11 Wood Cuts. Price 3s. bound.

INSTRUCTIVE RAMBLES through London and its Environs. By Mrs. HELME.

The 4th Edit. complete in one vol. Price 4s. 6d. bound.

"Much topographical and historical knowledge is contained in this volume, mingled with pertinent reflections." *Crit. Rev.*

MATERNAL INSTRUCTION; or, Family Conversations, on moral and interesting Subjects, interspersed with History, Biography, and original Stories. Designed for the Perusal of Youth.

By ELIZABETH HELME.

The 3d Edit. In 12mo. Price 4s. 6d. in Boards.

"There is something in the plan of the present little work particularly pleasing. It is with great pleasure that we recommend a work, the design of which is so sensible, and the execution so satisfactory." *Brit. Crit.*

THE HISTORY of ENGLAND, related in Familiar Conversations, by a Father to his Children. Interspersed with moral and instructive Remarks and Observations on the most leading and interesting Subjects. Designed for the Perusal of Youth.

By ELIZABETH HELME.

The 2d Edition. In 2 vols. 12mo. Price 8s. bound, with Frontispieces.

"The present performance seems exceedingly well adapted to the proposed purpose, and it is worthy of a respectable place in the Juvenile Library." *Brit. Crit.*

LETTERS addressed to a YOUNG LADY, wherein the Duties and Characters of Women are considered chiefly with a Reference to prevailing Opinions.

By Mrs. WEST.

The 4th Edit. In 3 vols. 12mo. Price 1l. 1s. in Boards.

"We do not venture without mature deliberation to assert that not merely as critics, but as parents, husbands, and brothers, we can recommend to the ladies of Britain, 'The Letters of Mrs. West.'" *Crit. Rev.*

LETTERS addressed to a YOUNG MAN, on his Entrance into Life; and adapted to the peculiar Circumstances of the present Times.

By Mrs. WEST.

The 5th Edit. In 3 vols. 12mo. Price 2l. in Boards.

"This work appears to us highly valuable. The doctrines which it teaches are orthodox, temperate, uniform, and liberal; and the manners which it recommends are what every judicious parent would wish his son to adopt." *Brit. Crit.* "We consider these letters as truly valuable, and would strongly recommend them to the attention of our younger friends." *Crit. Rev.* "We cannot withhold our tribute of praise which a work of such superlative merit demands." *Guard. of Educ.*

A GRAMMAR of the GREEK LANGUAGE, on a new and improved Plan, in English and Greek.

By JOHN JONES,

Member of the Philological Society at Manchester. Neatly printed in 12mo. The 2d Edition. Price 6s. in Boards.

"This work is in reality what in the title-page it professes to be, a Greek Grammar upon an improved, as well as a new plan. We cannot but regard Mr. Jones's Greek Grammar as a book that will be peculiarly serviceable to those who study or teach the Greek language." *Imp. Rev.* "It exhibits many proofs of ingenuity and extensive research, of a mind acute and vigorous, and habitually, and often successfully, employed in philosophical investigations." *Ann. Rev.*

A New TREATISE on the USE of the GLOBES; or, a Philosophical View of the Earth and Heavens; comprehending an Account of the Figure, Magnitude, and Motion of the Earth; with the natural Changes of its Surface, caused by Floods, Earthquakes, &c. designed for the Instruction of Youth. By THOMAS KEITH.

In one vol. 12mo. with Plates. The 3d Edit. Price 6s. 6d. "This volume comprehends a great quantity of valuable matter in a small compass, and we think it cannot fail to answer the purposes for which it is designed." *Brit. Crit.* "This work is ably executed." *Gen. Rev.*

GREEK EXERCISES, in Syntax, Ellipses, Dialects, Prosody, and Metaphrases, (after the Manner of "Clarke's and Mair's Introduction to the making of Latin,") adapted to the Grammars of Etou, Wettenhall, Moore, Bell, and Holmes. To which is prefixed, a concise and comprehensive Syntax. By the Rev. WILLIAM NEILSON, D.D. Minister of Dundalk, Ireland. The 3d Edit. In one vol. 8vo. Price 5s. in Boards; and with the Key, 8s.

"This work strictly fulfils the professions of the title-page." *Ecl. Rev.*

GREEK IDIOMS, exhibited in Select Passages from the best Authors, with English Notes and a Passing Index. To which are added, Observations on some Idioms of the Greek Language.

By the Rev. W. NEILSON, D.D. M.R.I.A. In 8vo. Price 5s. bound.

AN UNIVERSAL FRENCH GRAMMAR, being an accurate System of French Accidence and Syntax, on an improved Plan. By NICHOLAS HAMEL.

The Fifth Edition. Price 4s. bound.

"Of the many excellent French Grammars now in use, this is among the best."—"It is both comprehensive and concise, and is as well adapted as most Grammars for the use of schools."—"He has composed his work on sound principles and exact definitions."—"His book demands our commendation."

GRAMMATICAL EXERCISES upon the FRENCH LANGUAGE, compared with the English.

By NICHOLAS HAMEL.

The 7th Edit. with great Improvements. Price 4s. bound.

THE WORLD in MINIATURE; containing a curious and faithful Account of the Situation, Extent, Productions, Government, Population, Dress, Manners, Curiosities, &c. &c. of the different Countries of the World, compiled from the best Authorities; with proper References to the most essential Rules of the French Language, prefixed to the Work, and the Translation of the difficult Words and Idiomatical Expressions: a Book particularly useful to Students in Geography, History, or the French Language. By NICHOLAS HAMEL.

The 3d Edit. In one vol. 12mo. Price 4s. 6d. bound.

SCANNING EXERCISES for YOUNG PROSODIANS, containing the first Two Epistles from the Electæ of Ovidio, scanned and proved by the Rules of the Eton Grammar, and interspersed with occasional Remarks. By J. CAREY, LL.D. Price 4s. in Boards.

"This little work consists of a very minute critical analysis of two Epistles of Ovid, Deanaia Herculi, and Medea Jasoni. From the known character of the author, it is needless to observe that it is performed with accuracy." *Ann. Rev.*

LATIN PROSODY MADE EASY. By J. CAREY, LL.D. Besides other material Improvements, in almost every Page, this Edition contains a minute Account of above Fifty different Species of Verse.—Further Notices of ancient Pronunciation—a Dissertation on the Power of the Initial S.—Metrical Key to Horace's Odes.—Synopsis of nis Metres.—A copious Index, &c. &c. In 8vo. A new Edit. considerably enlarged and improved. Price 10s. 6d. Boards.

"This work appears to us likely to prove a very useful publication. The rules are given in Latin verse, and afterwards explained and elucidated in English. The author seems to thoroughly understand the principles of his subject; and he has treated it fully, accurately, and ingeniously." *Mon. Rev.*

AN ALPHABETIC KEY to PROPRIA QUÆ MARIBUS, QUÆ GENUS, and AS IN PRESENTI, containing all the Examples declined and translated, with the Rules quoted under each, and numerical References to the Context. By J. CAREY, LL.D.

In one vol. 12mo. Price 2s. 6d. bound.

AN ABRIDGMENT of the LATIN PROSODY MADE EASY, for the Use of Schools; containing as much of the Information given on each Subject in the larger Work as appeared suited to the Use and Capacity of young Prosodians. In 12mo. Price 3s. 6d. in Boards.

"Dr. Carey has rendered an acceptable service to younger students by this abridgment of his useful work on Prosody, and we cordially recommend it to the notice of teachers." *Ann. Rev.* 1808.

A KEY to CHAMBAUD'S EXERCISES; being a correct Translation of the various Exercises contained in that Book. By E. J. VOISIN.

The 2d Edition. Price 4s. bound.

THE ARITHMETICIAN'S GUIDE; or, a Complete Exercise Book, for the Use of public Schools and private Teachers. By WILLIAM TAYLOR, Teacher of the Mathematics, &c. The 6th Edit. In 12mo. Price 3s. bound.

HISTORICAL and MISCELLANEOUS QUESTIONS for the Use of Young People; with a Selection of British and General Biography, &c.

By RICHMAL MANGNALL.

The 9th Edition, corrected, in 12mo. Price 4s. 6d. bound. *A few Copies on fine Paper, and hot-pressed. Price 6s. bound.

THE CHILD'S MONITOR; or, Parental Instruction. In Five Parts, containing a great Variety of Progressive Lessons, adapted to the Comprehension of Children; calculated to instruct them in Reading, in the Use of Stops, in Spelling, and in dividing Words into proper Syllables; and at the same Time to give them some Knowledge of Natural History, of the Scriptures, and of several other sublime and important Subjects.

By JOHN HORNSEY.

The 2d Edition. Price 3s. 6d. bound.

"This is one of the best conceived and most practically useful publications for children that we have seen. The title-page sufficiently explains the intelligent author's plan and design, and we can safely assure our readers that he has executed them with equal skill and fidelity." *Anti Jac.*

THE BOOK of MONOSYLLABLES; or, an Introduction to the Child's Monitor, adapted to the Capacities of young Children. In Two Parts, calculated to instruct by familiar Gradations in the first Principles of Education and Morality.

By JOHN HORNSEY. Price 1s. 6d.

"The obvious utility of this plan is such as to require no comment. Mr. Hornsey has executed it in a manner highly creditable to his ingenuity and industry; for he has contrived not only to convey the proposed information to his young readers, but to blend with it much moral and religious instruction." *Anti Jac.*

A SHORT GRAMMAR of the ENGLISH LANGUAGE, simplified to the Capacities of Children. In Four Parts. 1. Orthography. 2. Analogy. 3. Prosody. 4. Syntax. With Remarks and appropriate Questions.—Also, an Appendix, in Three Parts. 1. Grammatical Resolutions, &c. 2. False Syntax, &c. 3. Rules and Observations for assisting young Persons to speak and write with Perspicuity and Accuracy. By JOHN HORNSEY.

A new Edition, corrected and greatly improved. Price 2s. bound.

THE PRONOUNCING EXPOSITOR; or, A NEW SPELLING BOOK. In Three Parts.

By JOHN HORNSEY. In 12mo. Price 2s. bound.

THE NEW YOUNG MAN'S COMPANION; or, the Youth's Guide to General Knowledge, designed chiefly for the Benefit of private Persons of both Sexes, and adapted to the Capacities of Beginners. In Three Parts. By JOHN HORNSEY.

In one vol. 12mo. Price 4s. bound, embellished with Four Copper-plates, and 28 Wood Cuts.

A VOCABULARY; English and Greek, arranged systematically, to advance the Learner in scientific as well as verbal Knowledge. Designed for the Use of Schools. By NATHANIEL HOWARD. Price 3s.

"The Greek language is so copious that few persons ever master the vocabulary. The present work is well calculated to expedite the knowledge of those terms of natural history, of art, and science, which are commonly the last learned, and the first forgotten." *Crit. Rev.*

THE NEW PANTHEON; or, an Introduction to the Mythology of the Ancients, in Question and Answer. Compiled principally for the Use of Females

By W. JILLARD HORT.

The 3d Edition, with Plates. Price 5s. in Boards.

"The new Pantheon is scrupulously delicate; it is also well arranged, and well written." *Ecl. Rev.* "It would be unjust not to recommend this work as an elegant and useful companion to young persons of both sexes." *Genl. Mag.*

AN INTRODUCTION to the STUDY of CHRONOLOGY and UNIVERSAL HISTORY.

By W. JILLARD HORT. In one vol. royal 18mo. Price 4s.

AN INTRODUCTION to the STUDY of BOTANY.

By J. E. SMITH, M.D. F.R.S. P.L.S.
The 2d Edition. In one vol. 8vo. with 15 Plates. Price 1*q*s. in Boards.

*A few Copies are coloured by desire. Price 1*l*. 8*s*. 6*d*s.
The Plan of this Work is to render the Science of Botanical Arrangement as well as the general Structure and Anatomy of Plants accessible, and in every Point eligible for young Persons of either Sex, who may be desirous of making this elegant and useful Science a Part of their Education or Amusement.

LESSONS for YOUNG PERSONS in HUMBLE LIFE, calculated to promote their Improvement in the Art of Reading, in Virtue and Piety, and particularly in the Knowledge of the Duties peculiar to their Stations.

The 3d Edition. Price 3*s*. 6*d*. in Boards.
"Very neatly printed, and well selected, containing a great store of instruction in a small compass." *Brit. Crit.* "In appearance, cheapness, and moral tendency, this compilation resembles those of the excellent Lindley Murray. It inculcates the most useful sentiments in a very suitable form, and well deserves patronage." *Elect. Rev.*

TRUE STORIES ; or, Interesting Anecdotes of young Persons, designed, through the Medium of Example, to inculcate Principles of Virtue and Piety. By the Author of "Lessons for young Persons in Humble Life," &c. In 12mo. Price 4*s*. 6*d*. in Boards.

TRUE STORIES ; or, Interesting Anecdotes of CHILDREN, designed, through the Medium of Example, to inculcate Principles of Virtue and Piety. By the Author of "Lessons for young Persons in Humble Life." Price 4*s*. 6*d*. in Boards, embellished with an emblematical Frontispiece.

"This is another agreeable and indeed useful addition to the youthful library, containing many amusing tales and instructive lessons." *Brit. Crit.*

A FRIENDLY GIFT for SERVANTS and APPRENTICES, containing the Character of a good and faithful Servant, Advice to Servants of every Denomination, Letter from an Uncle to his Nephew, on taking him Apprentice; and Anecdotes of good and faithful Servants. By the Author of "Lessons for young Persons in Humble Life." Price 6*d*.

MATHEMATICS SIMPLIFIED, and PRACTICALLY ILLUSTRATED, by the Adaptation of the principal Problems to the ordinary Purposes of Life, and by a progressive Arrangement applied to the most familiar Objects in the plainest Terms; together with a complete Essay on the Art of surveying Lands, &c. by such simple Inventions as may for ever banish the Necessity of costly and complex Instruments.

By THOMAS WILLIAMSON,
Author of the Wild Sports of India. In 8vo. with 23 Plates. Price 9*s*. in Boards.

INSTITUTES of LATIN GRAMMAR.

By JOHN GRANT, A.M. In 8vo. Price 10*s*. 6*d*. Bds.
"These Institutes display considerable ability, great diligence, and philosophical insight into the structure of language." *M. Rev.*

RUDIMENTS of ENGLISH GRAMMAR, for the Use of Schools.

By the Rev. HENRY ST. JOHN BULLEN, M.A.
Of Trinity College, Cambridge, and Head Master of the Grammar School, Leicester. The 3d Edit. Price 2*s*. 6*d*. bd.

A NEW and EASY INTRODUCTION to the HEBREW LANGUAGE; upon the Plan of Grammar in general. Designed to encourage and promote the Study of that Language, by facilitating the Acquisition of its Principles upon a Plan, which in no Work of the Kind has hitherto been adopted.

By the Rev. JAMES WILLIAMS NEWTON, M.A.
Minor Canon of the Cathedral Church of Norwich. The 2d Edition. Price 4*s*. in Boards.

LETTERS on the STUDY and USE of ANCIENT and MODERN HISTORY. Containing Observations and Reflections on the Causes and Consequences of those Events which have produced any conspicuous Change in the Aspect of the World, and the general State of Human Affairs.

By JOHN BIGLAND.
The 3d Edition. In one vol. demy 8vo. embellished with an elegantly engraved Head of the Author. Price 10*s*. 6*d*. ; or one vol. 12mo. Price 6*s*. in Boards.

"Mr. Bigland displays in this volume a well cultivated and comprehensive mind. His style is generally correct; his information is extensive; and the many pertinent remarks and inferences with which he has enriched this summary of general history, meet our cordial approbation." *Mon. Rev.*

LETTERS on NATURAL HISTORY, exhibiting a View of the Power, the Wisdom, and Goodness of the Deity. So eminently displayed in the Formation of the Universe, and the various Relations of Utility which inferior Beings have to the Human Species. Calculated particularly for the Use of Schools, and young Persons in general of both Sexes; in order to impress their Minds with a just Knowledge of the Creation, and with exalted Ideas of its Great Author. Illustrated by upwards of 100 engraved Subjects, applicable to the Work. By JOHN BIGLAND.

The 2d Edit. in one vol. 12mo. illustrated by Plates. Price 7*s*. 6*d*.

"We recommend our young readers to peruse the present work as a compilation of very useful and entertaining information, free from indelicate allusions, and interspersed with useful reflections." *Ecl. Rev.*

THE BRITISH CICERO; or, a Selection of the most admired Speeches in the English Language, arranged under Three distinct Heads of Popular, Parliamentary, and Judicial Oratory, with Historical Illustrations. To which is prefixed, an Introduction to the Study and Practice of Eloquence. By THOMAS BROWN, LL.D. Author of "Viridarium Poeticum," the "Union Dictionary," &c. &c. In 3 vols. 8vo. Price 1*l*. 11*s*. 6*d*. Boards.

ADVICE to YOUNG LADIES on the IMPROVEMENT of the MIND, and the CONDUCT of LIFE.

By THOMAS BROADHURST.
The 2d Edit. greatly improved. Price 5*s*. in Boards.
"It is impossible to read these pages without feeling a respect for the author, who has addressed his pupils in such a strain of calm good sense, and with so warm and affectionate a solicitude for their welfare. Here are no tricks of composition, to flatter the ear and deceive the understanding, but wise principles are inculcated in a chaste unaffected language. Advice on the various subjects of literature, science, and moral conduct, is rarely given in a more engaging manner." *Ann. Rev.*

A CONCISE VIEW of the CONSTITUTION of ENGLAND. By GEORGE CUSTANCE.

The 2d Edition, corrected and enlarged. In 12mo. Price 7*s*. in Boards. Also in 8vo. Price 10*s*. 6*d*. in Boards.

"We most sincerely congratulate the Public on the appearance of a work, which we can safely recommend as well fitted to supply a chasm in our system of public instruction. Of the merits of the work, the Public may form some judgment, when we inform them that it contains whatever is most interesting to the general reader in Blackstone, together with much useful information derived from Professor Christian, De Lolme, and various other eminent authors." *Ecl. Rev.*

MORAL TALES for YOUNG PEOPLE.

By Mrs. IVES HURRY. In 12mo. Price 4*s*. in Boards.
"Agreeably to the intention of the author, these Tales are calculated for the use of juvenile readers. The different effects which follow either a judicious and praiseworthy, or an improper and wicked conduct in young persons, are forcibly portrayed; and thus are many good lessons for a proper demeanour pleasingly taught." *Mon. Rev.*

An EXPLANATORY PRONOUNCING DICTIONARY of the FRENCH LANGUAGE, in French and English, wherein the exact Sound and Articulation of every Syllable are distinctly marked (according to the Method adopted by Mr. Walker in his Pronouncing Dictionary); to which are prefixed the Principles of the French Pronunciation, Prefatory Directions for using the Spelling Representative of every Sound, and the Conjugation of the Verbs, regular, irregular, and defective, with their true Pronunciation. By L'ABBE TARDY, Late Master of Arts in the University of Paris. A new Edition, revised. In 12mo. Price 7*s*. bound.

AN ABRIDGMENT of UNIVERSAL HISTORY. Adapted to the Use of Families and Schools, with appropriate Questions at the End of each Section.

By the Rev. H. I. KNAPP, A.M.
The 2d Edit. In 1 vol. 12mo. Price 4*s*. 6*d*. bound.

"This abridgment is executed with much judgment, knowledge, and propriety; a due sense of proportion is observed; the details expand as the events become important, and a morality, religiously tolerant and politically passive, pervades the reflections." *Mon. Rev.*

AN INTRODUCTION to the THEORY and PRACTICE of PLAIN and SPHERICAL TRIGONOMETRY, and the Stereographical Projection of the Sphere: including the Theory of Navigation; comprehending a Variety of Rules, Formulae, &c. with their practical Applications to the Mensuration of Heights and Distances, to determining the Latitude by Two Altitudes of the Sun, the Longitude by the lunar Observations, and to other important Problems on the Sphere, and on Nautical Astronomy.

By THOMAS KEITH,
Private Teacher of the Mathematics. In 8vo. Price 12*s*. in Boards. The 2d Edition, corrected and improved.

A FAMILIAR INTRODUCTION to the ARTS and SCIENCES, for the Use of Schools and young Persons; containing a general Explication of the Fundamental Principles and Facts of the Sciences; divided into Lessons, with Questions subjoined to each, for the Examination of Pupils. By the Rev. J. JOYCE, Author of Scientific Dialogues, &c. In one vol. 12mo. Price 6s. in Boards, illustrated with Copper plates by Lowry, and Wood-cuts by Branton.

"The method adopted is to lay down the principles of the different sciences in a series of short propositions, which are to be committed to memory, and are divided into lessons of appropriate length. We deem ourselves fully justified in recommending the volume to parents and instructors, as containing much useful matter in a cheap and convenient form." *Mon. Rev.*

AN INTRODUCTION to PRACTICAL ARITHMETIC. In Two Parts, with various Notes, and occasional Directions for the Use of Learners.

By THOMAS MOLINEUX, Many Years Teacher of Accounts, Short-hand, and the Mathematics, at the Free Grammar School in Macclesfield. The 6th Edition. Part I. Price 2s. 6d.—and Part II. Price 2s. 6d.

A COMPLETE TREATISE on PRACTICAL LAND SURVEYING. In Six Parts.

By A. NESBIT, Land Surveyor and Teacher of the Mathematics, at Farnley, Leeds. In 8vo. Price 9s. in Boards, designed chiefly for the Use of Schools, illustrated with a Number of Copper-plates, upwards of 100. Wood-cuts, and an engraved Field Book of 16 Pages.

The Whole explained and simplified in such a Manner as will, the Author hopes, render ample Assistance, both in Theory and Practice, to Teachers occupied in disseminating the Knowledge of this useful Branch of Geometry, or to those Persons who desire to become their own Instructors.

RULES for ENGLISH COMPOSITION; and particularly for THEMES; designed for the Use of Schools, and in Aid of Self-Instruction.

By JOHN RIPPINGHAM.

In 12mo. Price 3s. 6d. in Boards.

THE PANORAMA of YOUTH.

The 2d Edit. In 2 vols duodecimo. Price 9s. in Boards,

Poetry.

THE LADY of the LAKE. A Poem. In Six Cantos. By WALTER SCOTT, Esq.

Handsomely printed in 8vo. by Ballantyne. Price 12s. in Boards. The 5th Edition.

ILLUSTRATIONS of MR. WALTER SCOTT'S POEM of the LADY of the LAKE, engraved from a beautiful Set of Paintings, by Mr. Richard Cook, in the first Style of Excellence, by Warren, Anker Smith, Charles Heath, Armstrong, and Engleheart. Price in 4to. Proofs, on India Paper, 1l. 10s.; Prints in 8vo. 15s.; and with the Poem, in 8vo. 1l. 7s. in Boards.

The Pictures are now exhibiting at No. 54, New Bond-Street.

THE LAY of the LAST MINSTREL. A Poem, with Ballads and Lyrical Pieces.

By W. SCOTT, Esq. Elegantly printed by Ballantyne, on superfine wove Paper, and hot-pressed. The Tenth Edition, in 4to. Price 2l. 2s. in Boards. A few Copies are printed on fine Paper, price 3l. 13s. 6d. in Bds. Also an Edit. in 8vo. 10s. 6d. Bds.

ILLUSTRATIONS of the LAY of the LAST MINSTREL, consisting of Twelve Views of the Rivers Bothwick, Ettrick, Yarrow, Tiviot, and Tweed. Engraved by James Heath, R.A. from Drawings taken on the Spot. By J. SCHEATKY, Esq. of Oxford.

To which are affixed, Descriptions and Annotations, by Mr. Walter Scott. In one vol. 4to. Price 1l. 11s. 6d.; or on large Paper, and Proof Impressions, price 2l. 12s. 6d. in Boards. Also an Edition in 8vo. Price 10s. 6d.

"This volume not only supplies very interesting illustrations of Mr. Scott's Poem, but the Engravings being in themselves elegant representations of picturesque Scenery, are acceptable as explanatory of Scottish History and Topography, without reference to that popular production." *Mon. Rev.*

THE MINSTRELSY of the SCOTTISH BORDER; consisting of Historical and Romantic Ballads, collected in the Southern Counties of Scotland; with a few of a modern Date, founded on local Tradition. With an Introduction, and Notes, by the Editor,

WALTER SCOTT, Esq. Advocate.

The 4th Edition. In 3 vols. Price 1l. 16s. in Boards.

BALLADS and LYRICAL PIECES.

By WALTER SCOTT, Esq.

The 2d Edition. In one vol. 8vo. Price 7s. 6d. in Boards.

SIR TRISTRAM, a Metrical Romance of the Thirteenth Century.

By THOMAS of ERCILDOUNE, called THE RHYMER. Edited from the Auchinleck MS. by WALTER SCOTT, Esq. The 3d Edition. In royal 8vo. Price 15s. in Boards.

THE POETICAL WORKS of WALTER SCOTT, Esq. Complete in 7 vols. royal 8vo.

THE MOTHER. A Poem, in Five Books. By Mrs. WEST.

The 2d Edition. In foolscap 8vo. Price 7s. in Boards. "Strong sense, maternal, patriotic, and above all Christian eeling, without a tincture of fanaticism, are the characteristics of his poem, which will be ever the delight of those who are formed or trained to feel as man should feel." *Brit. Crit.*

POEMS and PLAYS. By Mrs. WEST.

In 4 vols. foolscap 8vo. hot-pressed. Price 1l. 3s. Boards.

JOAN of ARC. An Epic Poem.

By ROBERT SOUTHEY.

In 2 vols. foolscap 8vo. The 4th Edit. Price 12s. Boards.

METRICAL TALES, and other Poems.

By ROBERT SOUTHEY.

In one vol. foolscap 8vo. Price 5s. 6d. in Boards.

POEMS, including the Visions of the Maid of Orleans.

By ROBERT SOUTHEY.

A new Edition. In 2 vols. Price 12s. in Boards.

THALABA the DESTROYER, a Metrical Romance, with copious Notes. By ROBERT SOUTHEY.

The 2d Edition, elegantly printed in 2 vols. foolscap 8vo. Price 14s. in Boards.

MADOC. A Poem. By ROBERT SOUTHEY.

In 2 vols. foolscap, elegantly printed by Ballantyne, with Four beautiful Vignettes. The 3d Edit. Price 14s. Boards. A few Copies of the original Quarto Edition may be had. Price 2l. 2s.

THE REMAINS of HENRY KIRKE WHITE, of Nottingham, late of St. John's College, Cambridge, with an Account of his Life. By ROBERT SOUTHEY.

The 4th Edit. In 2 vols. crown 8vo. Price 16s. Boards.

THE CURSE of KEHAMA. A Poem.

By ROBERT SOUTHEY.

The 2d Edit. In 2 vols. 12mo. Price 14s. in Boards.

GERTRUDE of WYOMING, and MISCELLANEOUS POEMS; amongst which are O'Conner's Child, and other Poems never before published.

By T. CAMPBELL, Author of "The Pleasures of Hope." The 4th Edition. In foolscap 8vo. Price 9s. in Boards.

POEMS. By WILLIAM WORDSWORTH, Author of the Lyrical Ballads. In 2 vols. foolscap 8vo. Price 11s.

THE WANDERER of SWITZERLAND, and other Poems. By JAMES MONTGOMERY.

The 6th Edit. In one vol. foolscap 8vo. Price 6s. Boards. "Mr. Montgomery displays a rich and romantic fancy, a tender heart, a copious and active command of imagery and language, and an irresistible influence over the feelings." *Zet. Rev.* For a very high character of this volume, see *An. Rev.* 1805.

THE WEST INDIES, and other Poems.

By JAMES MONTGOMERY,

Author of the Wanderer of Switzerland, &c. In one vol. foolscap 8vo. Price 6s. in Boards. Third Edition.

POEMS. By Mrs. OPIE. The 6th Edition, with a beautiful Frontispiece. Price 6s. in Boards.

"Mrs. Opie's volume of poems would have obtained for its author a very considerable reputation, though her former work had been wholly unknown." *Edin. Rev.*

THE WARRIOR'S RETURN, and other Poems.

By Mrs. OPIE.

With a Frontispiece. Price 6s. in extra Boards

THE WORKS OF THOMAS CHATTERTON, consisting of all the Pieces contained in Rowley's Poems, Chatterton's Miscellanies, and the Supplement; with more than an equal Portion of new Matter. In 3 large vols. 8vo. Price 1*l.* 11*s.* 6*d.* in Boards.

POEMS. By S. T. COLERIDGE. The 3d Edit. In folscap 8vo. Price 5*s.* 6*d.* in Boards.

THE REMAINS OF HESIOD, the ÆSCRYÆAN. Translated from the Greek into English Verse. With a Preliminary Dissertation and Notes.

By CHARLES ABRAHAM ELTON. To which are added, Specimens of the obsolete Version of Hesiod's Georgics. By George Chapman. In folscap 8vo. Price 12*s.* in Boards.

WALLACE; or, the FIGHT OF FALKIRK, a Metrical Romance. By Miss HOLFORD. The 2d Edition. In 8vo. Price 10*s.* 6*d.* in Boards.

POEMS. By Miss HOLFORD. Author of Wallace, or the Fight of Falkirk. In 8vo. Price 6*s.* Boards.

THE BANKS OF THE WYE. A Poem. In Four Books. By ROBERT BLOOMFIELD, Author of the Farmer's Boy. In folscap 8vo. with Plates. Price 5*s.* in Boards.

THE POETICAL WORKS OF HECTOR MACKNEILL, Esq. The 3d Edition. Embellished with elegant Engravings. In 2 vols. folscap 8vo. Price 12*s.* Boards.

BALLAD ROMANCES, and other Poems. By Miss ANNA MARIA PORTER. In folscap 8vo. Price 7*s.* Boards, with a fine Engraving.

SCENES OF INFANCY, descriptive of Teviotdale. By JOHN LEYDEN. The 2d Edition. In folscap 8vo. with a Frontispiece. Price 6*s.* in Boards.

PSYCHE; or, the LEGEND OF LOVE; and other Poems. By the late Mrs. HENRY TIGHE. With a Portrait of the Author, engraved by Caroline Watson. The 2d Edit. 8vo. Price 12*s.* in Boards.

"For elegance of design and accuracy of execution this much exceeds any poetical composition of the present day. While the hearts of our countrymen shall beat at the sweetest sounds of their native language, conveying as nature dictates the feelings of the purest passions, so long shall this tale of Psyche dwell on their ears, and they shall think the angel still is speaking." *M. Rev.*

THE HIGHLANDERS, and other Poems. By Mrs. GRANT. In one vol. folscap 8vo. The 3d Edition. Price 7*s.* in extra Boards.

Novels, Romances, &c.

THE REFUSAL. A Novel. By the Author of the "Tale of the Times,"—"Gossip's Story," &c. In 3 vols. 12mo. Price 1*l.* 1*s.* in Boards.

"The writings of Mrs. West are distinguished always not only by their powerful tendency to promote the best objects, morality and religion; in the present production all these qualities are conspicuous. To our feelings what it contains for amusement is good, but what it intimates or expresses for instruction is admirable." *Brit. Crit.*

A GOSSIP'S STORY, and LEGENDARY TALE. By Mrs. WEST. In 2 vols. 12mo. The 5th Edit. Price 7*s.* in Boards.

A TALE OF THE TIMES. By Mrs. WEST. In 3 vols. 12mo. The 2d Edit. Price 13*s.* 6*d.* sewed.

THE LOYALISTS. A Tale of other Times. By Mrs. WEST. In 3 vols. 12mo.

THE SCOTTISH CHIEFS. A Romance. By Miss JANE PORTER, Author of "Thaddeus of Warsaw," and "Remarks on Sir Philip Sidney's Aphorisms." In 5 vols. 12mo. The 2d Edition. Price 1*l.* 15*s.* in Boards.

THADDEUS OF WARSAW. A Novel. By Miss JANE PORTER.

The 6th Edition. In 4 vols. Price 18*s.* in Boards. "Thaddeus is a work of genius, and has nothing to fear at the candid bar of taste: he has to receive the precious meed of sympathy from every reader of unsophisticated sentiment and genuine feeling." *Imp. Rev.* "This work has more merit than can be ascribed to the crowd of productions of this class, and imitates virtuous and magnanimous sentiments." *Mon. Rev.*

DON SEBASTIAN; or, the HOUSE OF BRAGANZA. An Historical Romance. By Miss ANNA MARIA PORTER. In 4 vols. 12mo. Price 2*l.* in Boards.

"Miss Porter is entitled to rank among the best of our living novelists. To the leading traits of character with which history has furnished her, our author has of course added a thousand charms, and she has certainly succeeded, in interesting us extremely in the fate of Don Sebastian." *Crit. Rev.*

THE HUNGARIAN BROTHERS. By Miss ANNA MARIA PORTER.

In 3 vols. 12mo. The 2d Edit. Price 15*s.* in Boards. "The incidents of this novel are striking, and many of the characters are finely drawn. The two brothers are models of that chivalrous heroism with which Miss Porter has on other occasions proved herself to be intimately acquainted." *Crit. Rev.* "The fair author has displayed very considerable ingenuity, and an intimate acquaintance with those chords of the heart which can be touched with the liveliest interest and pleasure." *An. Rev.*

THE FATHER AND DAUGHTER. A Tale. By Mrs. OPIE.

The 5th Edit. with a Frontispiece. Price 4*s.* 6*d.* Boards. "This tale is replete with interest, and possesses pathos enough to affect the heart of the most callous of critical readers." *Mon. Rev.*

TEMPER; or, Domestic Scenes. A Tale. By Mrs. OPIE. In 3 vols. 12mo. Price 1*l.* 1*s.* Boards.

SIMPLE TALES. By Mrs. OPIE.

The 3d Edit. In 4 vols. 12mo. Price 1*l.* 1*s.* in Boards. "In the tales now before us we find much of the same merits as in her beautiful story of Adeline Mowbray; the same truth and delicacy of sentiment, the same graceful simplicity in the dialogue parts of the work; and the same happy art of presenting ordinary feelings and occurrences in a manner that irresistibly commands our sympathy and affection." *Ed. Rev.*

ADELINE MOWBRAY; or the Mother and Daughter. A Tale. By Mrs. OPIE.

The 3d Edit. In 3 vols. 12mo. Price 13*s.* 6*d.* in Boards. "These volumes are, both in their design and execution, so superior to those which we usually encounter under the title of Novels, that we can safely recommend them to the perusal of our readers." *Mon. Rev.*

THE MYSTERIES OF UDOLPHO. A Romance; interspersed with some Pieces of Poetry.

By ANN RADCLIFFE, Author of the Romance of the Forest. The 6th Edition. In 4 vols. 12mo. Price 1*l.* 4*s.* in Boards.

THE ROMANCE OF THE FOREST; interspersed with some Pieces of Poetry.

By ANN RADCLIFFE. The 7th Edition. In 3 vols. 12mo. Price 15*s.* in Boards.

A SICILIAN ROMANCE. By ANN RADCLIFFE.

The 4th Edition. In 2 vols. 12mo. Price 8*s.* in Boards.

THE CASTLES OF ATHLIN and DUNBAYNE. A Highland Story.

By ANN RADCLIFFE. The 4th Edit. 12mo. Price 3*s.* 6*d.* in Boards.

PALMERIN OF ENGLAND. By FRANCISCO DE MOREAS.

Corrected by Robert Southey, from the original Portuguese, with Amendments. In 4 vols. 8vo. Price 1*l.* 8*s.* Bds. "We must as fairly avow our opinion, that as faithful reflectors of the manners and sentiments of former years, it deserves a permanent place in our libraries as appendages to *Cid*, *Du Guesclin*, and *Petit Ichan de Saintie*, to *Froissart*, *Monstrelet*, and *Journé*." *Ann. Rev.*

LETTERS FROM ENGLAND. By DON MANUEL ALVAREZ ESPRIELLA.

Translated from the Spanish. The 2d Edition. In 3 vols. 12mo. Price 18*s.* in Boards.

"Viewing these Letters as spirited remarks on England, we must pronounce them to deserve the notice of English readers. They contain many particulars of which the generality of our countrymen are ignorant, and they are interspersed with anecdotes and *bon mots*, which end the narrative, and produce a good effect." *Mon. Rev.*

MEMOIRS OF MARMONTEL. Written by Himself. Containing his Literary and Political Life, and Anecdotes of the principal Characters of the Eighteenth Century. A new Edition, corrected throughout. In 4 vols. 12mo. Price One Guinea in Boards.

"This is one of the most interesting productions which has issued from the French press since the revolution." *Mon. Rev.*

THE BRITISH NOVELISTS, with an Essay and Biographical and Critical Prefaces.

By Mrs. BARBAULD.

In 50 vols. royal 18mo. uniform with the British Essayists. Price 12l. 12s. in Boards.

* This Collection includes the most esteemed Works of Richardson, Fielding, Smollett, De Foe, Goldsmith, Horace Walpole, Hawkesworth, Johnson, Graves, Moore, Mackenzie, Miss Burney, Mrs. Ratcliff, Mrs. Inchbald, Mrs. Charlotte Smith, Mrs. Clara Reeve, Mrs. Brooke, Mrs. Edgeworth, &c.

LETTERS from the MOUNTAINS; being the real Correspondence of a Lady, between the Years 1773 and 1803. In 3 vols. 12mo. The 4th Edit. 13s. 6d. Bds. "The charm of these Letters consists in their being the artless effusion of a superior mind. There is sterling good sense in most of her remarks on books, manners, education, &c. and a great share of originality. She always appears to us in a light at once respectable and amiable. Her understanding is strong, her fancy lively, her sensibility acute. She has the art of placing everything before our eyes; we see her, we hear her, and we become acquainted with her; and when we shut our book, we seem to take leave of a friend." *Ann. Rev.***MEMOIRS of an AMERICAN LADY,** with Sketches of Manners and Scenery in America, as they existed previous to the Revolution. By the Author of "Letters from the Mountains," &c. &c. In 2 vols. 12mo. The 2d Edition. Price 12s. in Boards.**SELF-CONTROL. A Novel.**The 5th Edit. In 3 vols. post 8vo. Price 17. 4s. Boards. "We ascribe great merit to this novel. Some of Laura's maxims deserve to become universal aphorisms, and the examples of her self-denial are told in a plain unaffected way." *Mon. Rev.***THE NOVELS of DANIEL DE FOE;** containing the Adventures of Robinson Crusoe, Memoirs of a Cavalier, Life of Colonel Jack, Adventures of Captain Singleton, and True Born Englishman, New Voyage round the World, History of the Plague of London, &c. In 12 vols. folscap 8vo. Price 3l. 12s. in Boards.**Gardening, &c.****A TREATISE on the CULTURE of THE VINE,** exhibiting new and advantageous Methods of propagating, cultivating, and training that Plant, so as to render it abundantly fruitful. Together with new Hints on the Formation of Vineyards in England.

By WILLIAM SPEECHLEY.

The 2d Edit. with Additions. In one vol. royal 8vo. illustrated with Six Copper-plates. Price 18s. in Boards.

A TREATISE on the CULTURE of THE PINE APPLE, and the Management of the Hot-House.

By WILLIAM SPEECHLEY.

The 2d Edition. In 8vo. Price 12s. in Boards.

HORTUS KEWENSIS; or, a CATALOGUE of the PLANTS cultivated in the Royal Garden at Kew.

By the late WILLIAM AITON.

The 2d Edition, enlarged by William Townsend Aiton, Gardener to His Majesty. Vol. I. II. and III. 8vo. Price 12s. each, in Boards.

A TREATISE on the CULTURE and MANAGEMENT of FRUIT TREES, in which a new Method

of Pruning and Training is fully described. To which is added, a new and improved Edition of "Observations on the Diseases, Defects, and Injuries, in all Kinds of Fruit and Forest Trees; with an Account of a particular Method of Cure." Published by Order of Government.

By WILLIAM FORSYTH, F.A.S. and F.S.A.

Late Gardener to His Majesty at Kensington and St. James's, Member of the Economical Society at St. Petersburg, &c. &c. The 5th Edit. with 13 folding Plates. Price 13s. Boards.

THE PLANTER'S KALENDAR; or, the Nurseryman and Forester's Guide.

By the late WALTER NICOL.

Edited and completed by Edward Sang, Nurseryman. In one vol. 8vo.

THE VILLA GARDEN DIRECTORY;

or, Monthly Index of Work to be done in Town and Villa Gardens, Sirubberies, and particularly with Hints on the Treatment of Shrubs and Flowers usually kept in the Green Room, the Lobby, and the Drawing-room. By W. NICOL. The 2d Edit. much improved. Price 7s. 6d. in Boards.

Miscellaneous.**A SELECTION of CURIOUS ARTICLES** from the GENTLEMAN'S MAGAZINE; containing, 1. Researches, Historical and Antiquarian.—2. Ancient and Modern Literature, Criticism, and Philology.—3. Philosophy and Natural History.—4. Letters to and from eminent Persons.—5. Miscellaneous Articles, including Anecdotes of extraordinary Persons, useful Projects and Inventions, &c. &c. In 4 large vols. 8vo. Price 24. 12s. 6d.

The Fourth Volume separate. Price 14s. in Boards.

* Extract of a Letter from Mr. Gibbon, the Historian, to Mr. Nichols, dated Lausanne, February 24, 1792. "I am tempted to embrace this opportunity of suggesting to you the idea of a work, which must be surely well received by the Public. That voluminous series (Gentleman's Magazine) of more than threescore years, now contains a great number of literary, historical, and miscellaneous articles of real value; they are at present buried in a heap of temporary rubbish; but if properly chosen and classed, they might revive to great advantage in a new publication of a moderate size."

SPECIMENS of the EARLY ENGLISH METRICAL ROMANCES, chiefly written during the early Part of the Fourteenth Century. To which is prefixed, an Historical Introduction, intended to illustrate the Rise and Progress of Romantic Composition in France and England.

By GEORGE ELLIS, Esq.

In 3 vols. post 8vo. Price 17. 11s. 6d. in Boards

SPECIMENS of the EARLY ENGLISH POETS, to which is prefixed, an Historical Sketch of the Rise and Progress of the English Poetry and Language.

By GEORGE ELLIS, Esq.

The 4th Edit. in 3 vols. post 8vo. Price 17. 16s. in Bds.

SPECIMENS of the LATER ENGLISH POETS, to the End of the last Century, with Preliminary Notices, intended as a Continuation of Mr. Ellis's Specimens of the early English Poets.

By ROBERT SOUTHEY.

In 3 vols. crown 8vo. Price 14. 11s. 6d. in Boards.

SPECIMENS of ENGLISH DRAMATIC POETS, who lived about the Time of Shakspeare, with Notes.

By CHARLES LAMB.

In crown 8vo. Price 10s. 6d. in Boards.

ILLUSTRATIONS of SHAKSPEARE, and of ANCIENT MANNERS, with Dissertations on the Clowns of Shakspeare, on the Collection of popular Tales, entitled Gesta Romanorum, and on the English Morris Dance.

By FRANCIS DOUCE.

In 2 vols. 8vo. with numerous Engravings. Price 17. 11s. 6d. in Boards.

A DESCRIPTIVE CATALOGUE of the ORIENTAL LIBRARY of the late TIPPOO SULTAN of MYSORE. To which are prefixed, Memoirs of Hyder Aly Khan, and his Son Tippoo Sultan.

By CHARLES STEWART, Esq. M.A.S.

Late Major of the Bengal Establishment, and Professor of Oriental Languages in the Honourable East India Company's College at Hertford. In one vol. 4to. Price 4l. 4s. in Boards.

As only 250 have been printed of this Work, it is requested that early Application be made for Copies,

MISCELLANEOUS PLAYS.

By JOANNA BAILLIE.

The 2d Edition. In 8vo. Price 9s. in Boards.

A SERIES of PLAYS; in which it is attempted to delineate the stronger Passions of the Mind; each Passion being the Subject of a Tragedy and a Comedy.

By JOANNA BAILLIE.

The 5th Edition. In 2 vols. 8vo. Price 18s. in Boards. Just published, Vol. III. Price 9s. in Boards.

THE FAMILY LEGEND. A Tragedy.

By JOANNA BAILLIE. In 8vo. Price 3s. 6d.

"The merits of this poem, in many points of view, are of no common order, and the revival of dramatic taste, if ever it is to arrive, must begin by the general approbation of such productions." *Brit. Crit.*

AN INTRODUCTION to the KNOWLEDGE

of rare and valuable Editions of the GREEK and LATIN CLASSICS, including an Account of Polygot Bibles; the best Greek, and Greek and Latin, Editions of the Septuagint and new Testament, the Scriptures de Re Rustica, Greek Romances, and Lexicons and Grammars.

By the Rev. T. FROGNALL DIBDIN, F.S.A.

In 2 vols. crown 8vo. The 3d Edition, with additional Authors, and Biographical Notices (chiefly of English Authors.) Price 18s. in Boards.

"We are decidedly of opinion that no bibliographical collection can be complete without Mr. Dibdin's volumes, which are, independent of the solid information they contain, frequently enlivened by literary anecdotes, and rendered generally interesting by great variety of observation and acuteness of remark." *Brit. Crit.*

THE THEORY and PRACTICE of finding

the LONGITUDE at Sea or Land. To which are added, various Methods of determining the Latitude of a Place, and Variation of the Compass; with New Tables.

By ANDREW MACKAY, LL.D. F.R.S. Edinburgh.

Mathematical Examiner to the Honourable the Corporation of Trinity House, the Honourable the East India Company, Christ's Hospital, &c. In 2 vols. royal 8vo. The 3d Edition, considerably improved and enlarged. Price 2l. 12s. 6d. in Boards.

A COLLECTION of MATHEMATICAL

TABLES, for the Use of the Practical Mathematician, Navigator, Surveyor, Students in Universities, and for Men of Business.

By ANDREW MACKAY, LL.D. F.R.S. Ed. &c.

In one vol. 8vo. Price 7s. in Boards.

THE COMPLETE NAVIGATOR ; or, an

easy and familiar Guide to the Theory and Practice of Navigation, with all the requisite Tables, &c. &c.

By ANDREW MACKAY, LL.D. F.R.S. Ed. &c.

Author of the Theory and Practice of finding the Longitude at Sea or Land, &c. In one large vol. 8vo. illustrated with Engravings, &c. The 2d Edition. Price 12s. bound.

"This is a clear, well-digested, and masterly performance, containing, besides what is useful in other publications, much new and important matter." *Anti Jac.* "This is evidently the work of a man of science, of one who understands the subject which he professes to teach. To us there appears to be nothing wanting for the complete instruction of the young mariner in nautical affairs." *Imp. Rev.*

THE OPINIONS of DIFFERENT AU-

THORS upon the PUNISHMENT of DEATH, selected at the Request of a Society having for its Object the Diffusion of Knowledge respecting the Punishment of Death, and the Improvement of Prison Discipline.

By BASIL MONTAGU, Esq. of Lincoln's Inn.

In one vol. 8vo. Price 8s. in Boards.

Just published, Vol. II. Price 12s. in Boards.

THE BRAZIL PILOT ; or, a Description

of the Coast of Brazil. Translated from the Portuguese of MANOEL PIMENTEL,

Principal Hydrographer to His Majesty, John the Fifth of Portugal. To which are added, Charts of some of its most considerable Ports, from MSS. never before published. In one vol. 4to. illustrated with 15 Charts. Price 1l. 1s. Boards.

THE LOUNGER'S COMMON-PLACE

BOOK: or, Miscellaneous Collections, in History, Science, Criticism, Poetry, and Romance. In 4 large vols. 8vo. Price 1l. 18s. 6d. in Boards.

Vol. IV. may be had separate. Price 7s. in Boards.

THE SHOOTING DIRECTORY.

By R. B. THORNHILL, Esq.

In one vol. 4to. with Plates. Price 1l. 11s. 6d. in Boards. Also a superior Edition, with the Plates coloured after Life. Price 3l. 3s. in Boards.

THE PRINCIPLES of KEEPING ACCOUNTS with BANKERS in Town and Country, with accurate and extensive Interest Tables, &c. on a new Plan; and a Treatise on Bills of Exchange and Notes.

By WILLIAM LOWRIE.

In 8vo. (under the Patronage and Recommendation of the Governor of the Bank of England, &c.) The 2d Edition, Price 12s. in Boards.

"The Tables in this book seem, as far as we can judge, to be accurate. Those relating to interest are, at the same time, particularly convenient. The Treatise on Bills is drawn up in a plain style. The information contained in it is agreeable to practice." *Brit. Crit.*

A new COLLECTION of ENIGMAS, CHA-

RADES, TRANSPPOSITIONS, &c. A new Edition. In one vol. royal 18mo. Price 4s. in Boards.

THE ELEMENTS of the SCIENCE of

WAR; containing the modern established and approved Principles of the Theory and Practice of the Military Science, viz. the Formation and Organization of an Army, and their Arms, &c. &c. Artillery, Engineering, Fortification, Tactics, Logistics, Grand Tactics, Castrametation, Military Topography, Strategic, Dialectic, and Politics of War. Illustrated by 75 Plates, on Artillery, Fortification, &c. and Plans of all the remarkable Battles fought since the Year 1675, including the great Battles since the French Revolution.

By WM. MULLER,

Lieut. of the King's German Engineers, D. P. N. A. S. and late First Public Teacher of Military Science at the University of Göttingen.

In 3 vols. 8vo. dedicated (with his Majesty's most gracious Permission) to the King. Price 3l. 3s. in Boards.

ESSAYS on the SUPERSTITIONS of the

HIGHLANDERS of SCOTLAND. To which are added, TRANSLATIONS from the GAELIC, and LETTERS connected with those formerly published.

By the Author of "Letters from the Mountains."

In 2 vols. 12mo. Price 12s. in Boards.

LETTERS of ANNA SEWARD. Written

between the Years 1784 and 1807. Beautifully printed in 6 vols. post 8vo. with Portraits. Price 3l. 3s. in Boards.

"She unquestionably ranks in the first class of British females; and the collection of letters which she has prepared for the public, will interest, amuse, and instruct." *Mon. Rev.*

BIOGRAPHIA DRAMATICA ; or, a Com-

pensation to the Playhouse, originally compiled by David Erskine Baker, to the Year 1764, continued thence to 1782.

By ISAAC REED, F.A.S.

And brought down to the End of November, 1811, with considerable Additions and Improvements throughout. By Stephen Jones. In 3 vols. 8vo. Price 2l. 8s. in Boards.

ELEMENTS of MUSICAL COMPO-

SITION; comprehending the Rules of thorough BASS, and the Theory of Tuning.

By WILLIAM CROTCH, Mus. Doc. Prof. Mus. Oxon.

In one vol. 4to. with many Plates. Price 1l. 1s. Boards.

THE BEE; consisting of Essays, Philosophi-

cal, Artlogical, and Miscellaneous Intelligence, respecting Arts, Literature, Manufactures, &c.

By JAMES ANDERSON, LL.D.

In 18 vols. crown 8vo. with Plates. Price 4l. 4s. Boards.

RECREATIONS in Agriculture, Natural

History, Arts, and Miscellaneous Literature.

By JAMES ANDERSON, LL.D.

In 6 vols. 8vo. Price 3l. 12s. Boards; on royal Paper, 7l. 2s. in Boards.

THE DRAMATIC WORKS of JOHN

FORD; with an Introduction, and explanatory Notes

By HENRY WEBER, Esq.

In 2 vols. royal 8vo. Price 2l. 2s.; and demy 8vo. Price 1l. 10s. in Boards.

A General HISTORY of QUADRUPEDS.

By THOMAS BEWICK.

The Sixth Edition. In 8vo. Price 20s. in Boards, with numerous Wood Cuts and Vignettes.

A HISTORY of BRITISH BIRDS.

By THOMAS BEWICK.

With numerous Wood Cuts and Vignettes. Demy 8vo. Price 1l. 4s. in Boards.

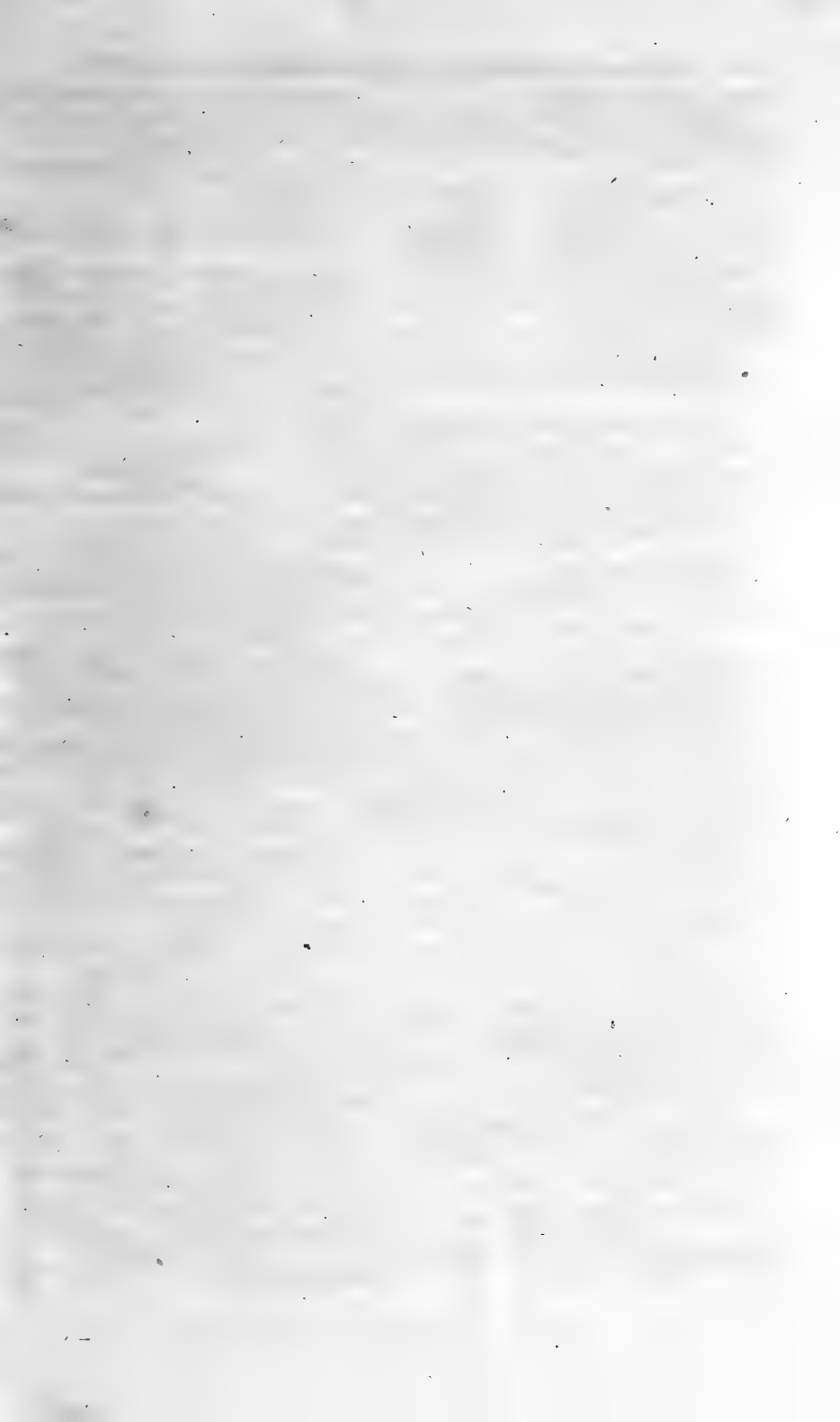

6230

