



3 1761 06705272 0

A PRACTICAL TREATISE
ON LEVELLING
FOR THE CIVIL ENGINEER
ARCHITECT AND STUDENT.

WITH EXAMPLES

PRICE 6/-

454
8

dup

Digitized by the Internet Archive
in 2007 with funding from
Microsoft Corporation



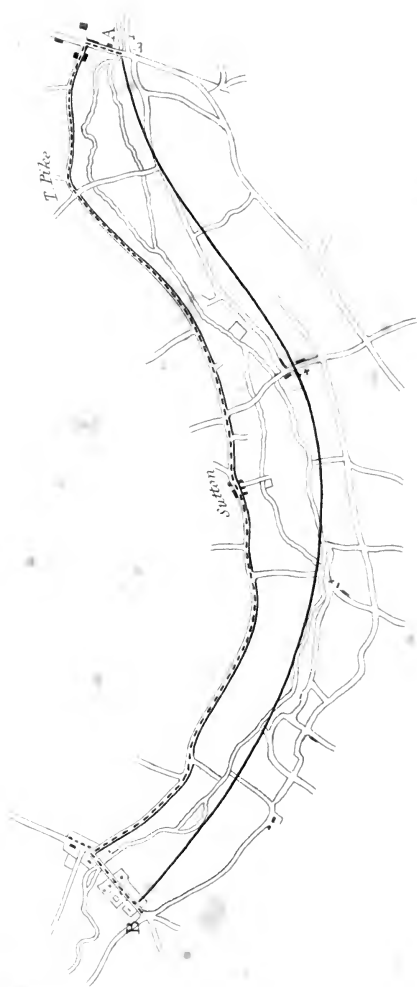
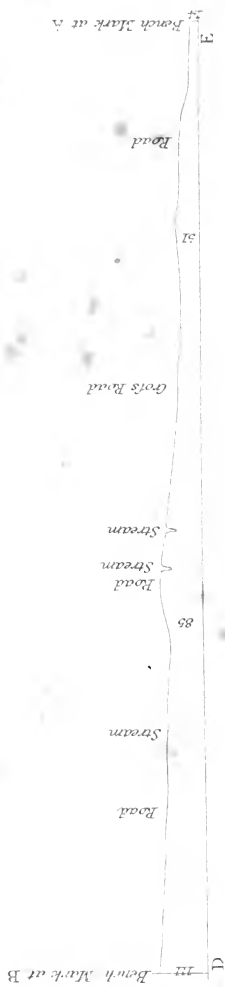

Engraved by H. Langley

Drawn by F. W. Simmons

Published by John Wade, Antiquarian, Library, 69, High Holborn

7E5

- 272 -

C. E. Detmold
1837

A TREATISE
ON THE
PRINCIPLES AND PRACTICE
OF
LEVELLING,

SHOWING ITS APPLICATION TO PURPOSES OF CIVIL ENGINEERING,
PARTICULARLY IN THE CONSTRUCTION OF ROADS,

WITH
MR. TELFORD'S RULES FOR THE SAME:

With an Appendix,

CONTAINING A DESCRIPTION OF

MR. MACNEILL'S DYNAMOMETER,

OR

INSTRUMENT FOR ASCERTAINING THE COMPARATIVE MERIT OF ROADS,
AND THE STATE OF REPAIR IN WHICH THEY ARE KEPT.

BY

FREDERICK W. SIMMS,

SURVEYOR AND CIVIL ENGINEER,

Late of the Royal Observatory, Greenwich,

Author of a Treatise on the Principal Mathematical Instruments employed
in Surveying, Levelling, and Astronomy.

WITH PLATES AND WOOD-CUTS.

JOHN WEALE,
ARCHITECTURAL LIBRARY, 59, HIGH HOLBORN.

1837.

WILLIAM TYLER,
PRINTER,
BOLT-COURT, FLEET-STREET.

1987
—
20/9/00

6

ADVERTISEMENT.

The following pages were written at the request of the Publisher, in consequence of the very numerous applications he had received for a book upon this subject. In doing this, it was suggested that, in addition to explaining the method of taking levels in the field, and afterwards transferring them to paper in the form of a section, I should add an example of their application to practical purposes; I have accordingly inserted an example of road-work, wherein the necessary calculations of earth-work are shown, and worked out in full, both by the Prismatic Formula, and the shorter process by the use of the tables of Mr. Macneill;—and, as in a manner connected with the subject, it was also suggested that I should add some particulars upon the choice of a line of direction through a country for a road or railroad, preparatory to

taking levels. In conclusion, I have given an abstract of the late Mr. Telford's rules for making and repairing roads, as contained in full in the valuable work of "Sir Henry Parnell on Roads."

An Appendix is added, with permission, containing a description of Mr. Macneill's instrument for the purpose of ascertaining the comparative merits of roads, and the state of repair in which they are kept.

F. W. S.

Greenwich, Dec. 3, 1836.

CONTENTS.

PART I.

On the Principles of Levelling.

	page
Figure of the earth	1
Difference between the true and apparent level	4
Rule for computing ditto	6
Example of computing ditto	7
Table of the difference of the apparent and true level for distances in miles	9
Table of ditto for distances in chains	10
Logarithmic rule for computing ditto	11
Levelling instruments	13
The Y level	
Troughton's improved level	
Gravatt's level	
Levelling staves	
The iron tripod	
The measuring chain	
On instrumental parallax	20
— the principles of the telescope, and of the line of col- limation	22
Arrangement of levelling operations	26

PART II.

The Practice of Levelling.

On running or check levels	31
Adjusting the instrument for observation, &c.	35
Example of field-work	44
Levels for the formation of a section.....	46
Example of field-work	49
Explanation of field-book	50
Reduction of levels.....	51
To draw the section	57
Table of reduction from hypthenusal to horizontal measure	60
Trial sections	61
To draw the section	63
Example of field-work	66
Levelling with the Theodolite	69

PART III.

*Computation of Earth-work, Road-making, the Clinometer,
&c.*

Application of a section to practical purposes	73
To draw lines of intended surface on sections, to arrange judiciously the earth-work.....	75

CONTENTS.

vii

Prismoidal formula.....	79
Example of computation of earth-work.....	80
Slopes, &c.....	90
Description of the clinometer.....	91
'Table of slopes corresponding to given angles	93
On selecting a line of country for a road or railway....	95
Mr. Telford's rules for making and repairing roads	101
Shape or transverse section	<i>ib.</i>
Drainage.....	102
Fences	<i>ib.</i>
Road materials	103
The foundation and disposition of materials	104
Repairing roads	106
Level employed in the construction of roads	108
Appendix	110

A TREATISE
ON LEVELLING.

PART I.

ON THE PRINCIPLES OF LEVELLING.

LEVELLING is the art of tracing a line at the surface of the earth which shall cut the directions of gravity every where at right angles. If the earth were an extended plane, all lines representing the direction of gravity at every point on its surface would be parallel to each other; but, in consequence of its figure being that of a sphere or globe,* they every where converge to a point within the sphere which is equi-distant from all parts of its surface; or, in other words,

* The figure of the earth is not exactly that of a sphere, but of an oblate spheroid flattened at the poles; the length of the equatorial diameter being 7924 miles, and that of the polar diameter 7898 miles. For our present purpose, it is sufficiently correct to consider it as a sphere.

the direction of gravity invariably tends towards the centre of the earth, and may be considered as represented by a plumb line when hanging freely, and suspended beyond the sphere of attraction of the surrounding objects.

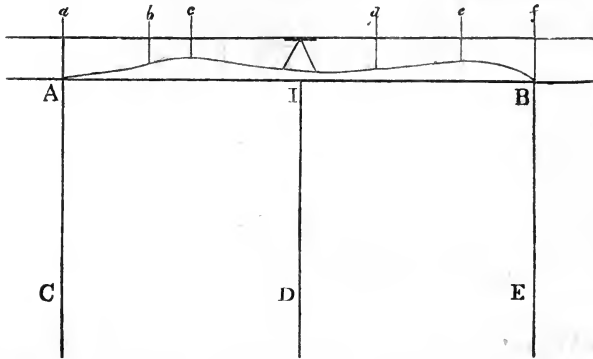

In the above diagram let the *straight* line A B represent the surface of the earth, upon the supposition of its being an extended plane, the direction of gravity at the points A, I, and B, would be represented by the lines A C, I D, and B E, all parallel to each other, and at right angles to the horizontal line A B. Now if the surface was undulatory, as shown by the curved line A B, and it was required to make a section representing it; an instrument capable of tracing out a line parallel to the horizontal line A B; (as a spirit-level,) might be set up any where on the surface, as at I, and staves being placed or held along the line, as at *a, b, c, d, &c.*, the dif-

ferent heights above the ground where such staves were intersected by the line so traced out, would at once show the relative level of all those points, with regard to the horizontal line, as a datum or standard of comparison.

But as the earth is a globe, its circumference must be circular, as I K L in the annexed figure ;

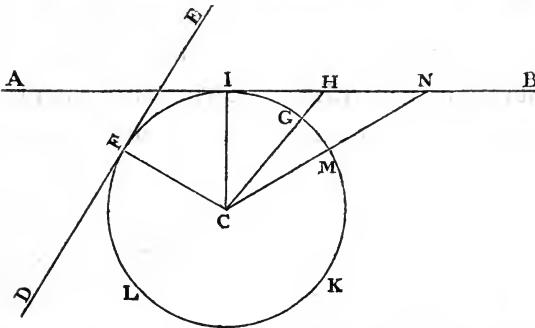

the straight line A B will therefore not represent the surface of the earth, but the sensible horizon of an observer stationed at the point I, to which point it is a tangent, being at right angles to the radius of the circle, (or semi-diameter of the earth,) I C. A line which is parallel to the sensible horizon of the observer, is the line traced out by our spirit-levels, and is a tangent to the earth's surface at that point only where the instrument is set up,—thus A B is a tangent at I, and D E a tangent at F ; such being the fact, the difference of level between any two points cannot be determined by simple reference to a

horizontal line, since every point on the surface of the globe (however near to each other) has a distinct horizon of its own.

If the earth was every where surrounded by a fluid at rest, or that its surface was smooth, regular, and uniform, every point thereon would be equally distant from the centre ; but, in consequence of the undulating form of the surface, places and objects are differently situated, some further from, and others nearer to the centre of the earth, and consequently at different levels. The operation of levelling may therefore be defined as the art of finding how much higher or lower any one point is than another, or, more properly, the difference of their distances from the centre of the earth.

Referring to our last figure, we have seen that the line A B is a true horizontal or level line at the point I, but being produced in the direction A or B, it rises above the earth's surface ; and although it may appear to be level as seen from I, yet it is above the true level, (which is represented by the circumference of the circle,) at every other point, and continues to diverge from it, the further it is produced ; at G, the apparent line of level, as the horizontal line A B is called, is above the true level, by the distance G H, and at M by the distance M N, *the difference being equal to the excess of the secant of the arc of distance above the radius of the earth.*

The difference, G H or M N, (see last figure,) between the true and apparent level may be thus found: put t in the adjoining diagram for the

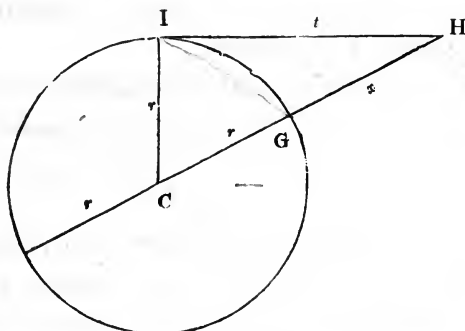

tangent I H, r for the radius C I of the earth, and x for GH, the excess of the secant of the arc of distance above the radius; I H being considered as equal to I G; then

$$\begin{aligned}(r+x)^2 &= r^2 + t^2 \\ \text{or } r^2 + 2rx + x^2 &= r^2 + t^2 \\ \text{and } 2rx + x^2 &= t^2 \\ \text{or } (2r+x)x &= t^2\end{aligned}$$

But because the diameter of the earth $2r$ is so great with respect to the quantity (x) sought at all distances to which a common levelling operation usually extends, that $2r$ may be taken for $2r+x$ without sensible error; we then have

$$\begin{aligned}2rx &= t^2 \\ \text{and } x &= \frac{t^2}{2r}\end{aligned}$$

Or in words : *The difference (x) between the true and apparent level is equal to the square of the distance (t²) divided by the diameter of the earth, (2r,) and consequently is always proportional to the square of the distance.*

The mean diameter of the earth is 7916 miles, and the excess of the apparent above the true level for one mile $\frac{t^2}{2r} = \frac{1}{7916}$ of a mile, or 8.004 inches. At two miles, it is four times that quantity, or 32.016 inches ; at three miles, it is nine times that quantity, or 72.036 inches ; and so on increasing in proportion to the square of the distance. If we reject the decimal .004, and assume the difference between the true and apparent level for one mile, to be exactly eight inches, or two-thirds of a foot, there arises the following convenient form for computing the correction of level due to the curvature of the earth, for distances given in miles, which may easily be remembered :—

$$\text{correction} = \frac{2D^2}{3}$$

D being the distance in miles. Or in words : *Two-thirds of the square of the distance in miles will be the amount of the correction, in feet.*

Example.

From a point on the Folkstone road, the top of the keep of Dover Castle was observed to coincide with the horizontal wire of a levelling telescope when adjusted for observation, and therefore was apparently on the same level; the distance (D) from the instrument to the Castle was four miles and a half: consequently,

$$D^2 = 20.25$$

$$2D^2 = 40.50$$

$$\frac{2D^2}{3} = 13.5 \text{ feet, the correction required.}$$

From this it appears, that the keep of Dover Castle was 13.5 feet higher than the centre of the telescope on the Folkstone road; but on account of the curvature of the earth, it was apparently depressed to the same level.

But the effect of the earth's curvature is modified by another cause, arising from optical deception; namely, Refraction. An object is never seen by us in its true position, but in the direction of the ray of light which conveys the impression or image of the object to our senses. Now the particles of light, in traversing the atmosphere, are, by the force of superior attraction, refracted or bent continually towards the perpendicular, as they penetrate the lower or

denser strata; and consequently they describe a curved track, of which the last portion, or its tangent, indicates the apparent elevated situation of a remote point. This trajectory, suffering almost a regular inflexure, may be considered as very nearly an arc of a circle, which has for its radius seven times the radius of our globe; in consequence of which, the distance at which an object can be seen by the aid of refraction, is to the distance at which it could be seen without that aid, nearly as 14 to 13, the refraction augmenting the distance at which an object can be seen by about a thirteenth of itself. Hence to correct the error occasioned by refraction, it will only be requisite to diminish the effects of the earth's curvature, or height of the apparent above the true level, by one-seventh of itself. Thus for our example of Dover Castle, $\frac{1}{7}$ of 13.5, or $\frac{13.5}{7}=1.93$ ft. nearly, to be subtracted from 13.5, which leaves 11.57 feet for the height of Dover Castle above the level of a certain point on the Folkstone road.

The following tables show the reduction of the apparent to the true level, both for the curvature of the earth only, and also for the combined effects of curvature and refraction. The first gives the corrections corresponding to distances expressed in miles, and the second for distances in chains.

Table of the Difference of the Apparent and True Level for Distances in Miles :—

Distance in Miles.	CORRECTION.			
	Curvature.		Curvature and Re- fraction.	
	Feet.	Inches.	Feet.	Inches.
$\frac{1}{4}$	0	0.5	0	0.4
$\frac{1}{2}$	0	2.0	0	1.7
$\frac{3}{4}$	0	4.5	0	3.9
1	0	8.0	0	6.9
2	2	8.0	2	3.4
3	6	0.0	5	1.7
4	10	8.1	9	1.8
5	16	8.1	14	3.5
6	24	0.1	20	7.0
7	32	8.2	28	0.2
8	42	8.3	36	7.1
9	54	0.3	46	3.7
10	66	8.4	57	2.1
11	80	8.5	69	2.1
12	96	0.6	82	3.9
13	112	8.6	96	7.4
14	130	8.8	112	0.7
15	150	0.9	128	7.6
16	170	9.0	147	2.3
17	192	9.2	165	2.7
18	216	1.3	185	2.8
19	240	9.4	206	4.7
20	266	9.6	228	8.2

Table of the Difference of the Apparent and True Level for Distances in Chains.

Distance in Chains.	CORRECTION.	
	Curvature in Deci- mals of Feet.	Curvature and Re- fraction in Deci- mals of Feet.
1	.000104	.000089
2	.000417	.000358
3	.000938	.000804
4	.001668	.001430
5	.002605	.002233
6	.003752	.003216
7	.005107	.004378
8	.006670	.005717
9	.008442	.007236
10	.010422	.008933
11	.012610	.010809
12	.015007	.012863
13	.017613	.015097
14	.020427	.017509
15	.023450	.020100
16	.026680	.022869
17	.030120	.025817
18	.033767	.028943
19	.037623	.032248
20	.041687	.035732
21	.045960	.039394
22	.050442	.043236
23	.055132	.047259
24	.060031	.051455
25	.065137	.055832
26	.070452	.060388
27	.075975	.065121
28	.081708	.070036
29	.087648	.075127
30	.093798	.080399

The correction for distances greater than those given in the latter table, may be computed by the following rule, the same by which the table itself was computed:—

Rule—*To the arithmetical complement of the logarithm of the diameter of the earth, or 2.3788603, add double the logarithm of the distance in feet, the sum will be the logarithm of the correction for curvature in feet and decimals; from which, if one-seventh of itself be subtracted, the result will be the combined correction for curvature and refraction.*

The practice of levelling is one of the most delicate operations that falls within the province of a surveyor, requiring the utmost possible circumspection to avoid the numerous sources of error to which he is liable. More especially, as it is seldom possible for him, after levelling over a long tract of country, to conjecture in what portion of the work his error lies, if he should then find that he had been so unfortunate as to commit any, and, not unfrequently in such cases, sufficient time cannot be spared to go over the ground again; as, for instance, when a section is required within a very limited time to produce before a parliamentary committee, either to support or oppose any measure submitted to their consideration. We have witnessed an instance where such a committee,

during their inquiry into the merits of a certain proposed line of rail-road, had brought before them a *rival contemplated line* with *pretensions to great superiority*; but it had been so hastily surveyed, that the learned counsel who had the supporting of the measure, acknowledged, in his opening address, that a trifling error at some unknown part of the line had been detected, which did not exceed fifty feet. We hardly need add, that the rival line was rejected.

The importance of extreme accuracy may also be felt, when it is known that from the section, the engineer has to make his calculations of the quantity of earthwork, in cuttings and embankments, necessary to carry into execution the intended measure, whether of a canal, a railway, or turnpike-road, and of course the accuracy of the estimated expense is involved in it; and further, the fitness of the ground itself for such works is determined from the section; that is, whether the inclinations, which the undulations of the ground admit of being introduced, are suitable for the purpose either of a railway or turnpike-road? And if the object be the formation of a canal, the section must show what extent of lockage will be required; not only affording a key to the expense, but also the possibility of its execution. We do not throw out these suggestions to alarm the mind of the young beginner,

by bringing before him a fearful responsibility, but that he may understand the ultimate object of his labours, and to induce him, by carefulness and attention, to merit that confidence which is sure to be reposed in those who are known to possess such habits.

LEVELLING INSTRUMENTS.

It is essential to the good execution of work, that the surveyor should possess instruments most proper for the purpose, and of the best construction. Upon the subject of instruments, we shall generally refer the reader to a cheap work, entitled, "A Treatise on the principal Mathematical Instruments employed in surveying, levelling, and astronomy, explaining their construction, adjustments, and use,"* where the various kinds of spirit-levels, and levelling-staves, together with the method of performing their several adjustments, &c., are minutely detailed, and represented by engravings; and as the work alluded to, contains also a similar account of the most important instruments used in surveying and astronomy, together with its extensive sale, we presume it to be in the hands of most beginners in the profession: we shall, however, give some particulars in this place, and annex a de-

* Second Edition enlarged, price six shillings. Sold for the Author, by the Publisher of this volume, and by Messrs. Troughton and Simms, Fleet-street.

scription of the cause of, and a remedy for, the *parallax* between the wires of a levelling telescope, and the levelling staves, which is the cause of much annoyance to observers.

SPIRIT-LEVELS.

The Y level, so called from the supports in which the telescope rests, resembling in shape the letter Y, is the oldest construction of the spirit-level now in use : its adjustments are convenient to be performed, but, on the other hand, this kind of instrument seldom retain their adjustments perfect for any length of time ; besides, there are conditions in its construction which are assumed to be perfect, but which practical men know to present difficulties in the manufacture. The use of this instrument is now very much superseded by those of modern construction.

Troughton's Improved Level.—This instrument has been a very general favourite among engineers for a length of time : its construction renders its adjustments much more permanent than those of the Y level, and it is altogether a more stable instrument. The telescope, which, in the former instrument, is capable of reversion in its supports for the adjustment of the line of collimation, is, in Troughton's construction, firmly fixed in its place, as is also the glass tube of the

spirit bubble. The verification and correction of the adjustments are performed very differently, and may at first appear more complex and difficult than those of the other ; yet when a person has once mastered and become familiar with his instrument, these apparent difficulties vanish.

Gravatt's Level.—This modification of the spirit-level has but recently been introduced by William Gravatt, Esq., and bids fair to become the favourite instrument among civil engineers. In its general figure, it does not differ very essentially from the level last spoken of, but it possesses many decided advantages. The aperture of the object glass is much larger for the same length of telescope, consequently more rays of light are admitted to the eye, producing the advantages of greater distinctness. We lately tried a *fourteen-inch* level, constructed upon Mr. Gravatt's principle, and found, that we could distinctly read the levelling staff at twenty chains (a quarter of a mile) distant, which was the utmost we could do with a *twenty-inch* level upon the old construction ; we have, therefore, the advantage of a more portable instrument, fourteen inches in length, capable of performing the same work as a more cumbersome one of twenty inches. Besides this advantage, the instrument in question is more complete in its details. It possesses a cross

level, placed at right angles to the principal level, which affords very great facility in setting up the instrument, and adjusting for observation, as will be hereafter described: it likewise has a reflecting mirror, mounted with a hinge joint, and capable of being placed on the principal level tube, and adjusted, to show the observer if the instrument shifts from its horizontality whilst he is noting the observation: it also possesses other important though minor additions, all of which, in fact, could be applied by the maker to the other kind of instruments, if ordered, and for the particulars of which, we refer to the work before alluded to.

From the large aperture, and short focal length of the telescope, the instrument has altogether a dumpy appearance, and hence it is generally known by the cognomen of "Gravatt's Dumpy Level:" usually of nine or fourteen inches. We have seen some beautiful specimens of this kind of levelling instrument constructed for I. K. Brunell, Esq., by Messrs. Troughton and Simms, of Fleet-street, by whom the first of the kind was made, by direction of the contriver.

LEVELLING STAVES.

In the Treatise on Mathematical Instruments before referred to, will be found a description of the different kind of levelling staves in use.

The former construction, even as improved by Troughton, was decidedly defective in practice, inasmuch as the staff had to be read off by the assistant, who had then to communicate the result to the observer; or, if he was not sufficiently intelligent to be intrusted with so responsible a duty, he was obliged, after the observation was made, to carry the staff to the observer, or wait for him to come and read off the height of the vane, and register it in his field-book. This occasioned great loss of time and uncertainty in the results, for the vane on the staff might possibly be shifted in the meantime. We remember an instance of an ignorant attendant holding the staff upside down, which at once introduced an error of several feet in the result. To obviate this, a new staff has been contrived, originally, we believe, by Mr. Gravatt, and subsequently by Mr. Hennett, Mr. Bramah, and Mr. Sopwith, &c., each varying the mechanical arrangements, but all agreeing in retaining the main advantage, viz., a sufficiently distinct graduated face for the observer to read off the quantities himself through the telescope of his instrument; the sliding vane is therefore dispensed with, and the only dependence to be placed on the staff-holder is, that he may hold it perpendicular. To assist him in this, a small plummet is suspended in a groove cut out in the

side of the staff, by which its verticality can be determined in one direction, and the observer himself can detect if it be held aslant in the other direction, as may be understood from the diagram at page 2, which represents the staff *e* as it appears in the field of the telescope, which shows objects inverted. If the staff is held perpendicular, it will appear between and equally distant from each of the two vertical wires *c d* fixed in the telescope ; consequently, if it be held aslant, it will cross the wires obliquely, and any want of verticality in the staff will be immediately detected, and the observer must signal to the staff-man accordingly. The advantages from the use of the modern staff, over those of the old construction, are so great, especially in saving of time, that we have no doubt of their general adoption.

THE IRON TRIPOD.

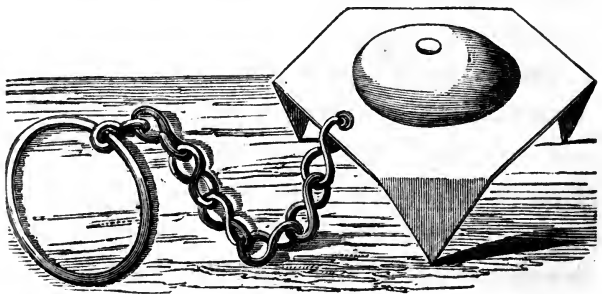

Another instrument of simple construction is represented in the adjoining figure; its use is to rest the staff upon when held at any station. By this means the staff is sure to be kept on the same spot, and at the same height from the ground, while the observer is reading the staves both at the back and forward station on each side of the spirit-level; it is at present not generally used, but we consider it of more importance than is usually attached to it. It consists of a triangular piece of sheet iron, of about one-tenth of an inch in thickness, having the corners turned down to form the feet of the tripod, which are to be pressed into the ground by the foot of the staff-holder; a rounded piece of iron is rivetted on the upper surface, to present a clean spot to rest the staff upon when held at the station; the chain with the attached ring is for the convenience of the staff-holder in lifting it from the ground, and carrying it from station to station.

THE MEASURING CHAIN.

In Levelling operations a Gunter's chain is required to measure the distance from staff to staff, or from the staff to the instrument, as the case may require, except in taking what are called running or check levels, the object of which is merely to test the accuracy of a section

previously made, by finding the difference of level between certain points on the section, to see if the results are identical with the former determination; which is the same thing as ascertaining the whole difference of level between distant places.

ON INSTRUMENTAL PARALLAX.

The foregoing is an account of the instruments necessary for the purposes of levelling; but before closing this part of our subject, we think it may be useful to add some particulars respecting instrumental parallax, which we have occasionally found to be the source of much annoyance to the surveyor. This has invariably arisen from ignorance of the principles of the telescope, and hence, not knowing how the parallax arises, the means of removing it has not been understood; we shall endeavour to explain, in a popular manner, both the cause and the remedy.

The rays of light which proceed from surrounding objects, and which, by entering our eyes, convey to us the sense of vision, move in perfectly straight lines, unless turned from their rectilinear course by the intervention of a refracting or reflecting medium, and whatever portion of such rays as can enter our eyes may (without sensible error) be considered as moving

not only in *straight*, but *parallel* lines ; the more remote the object is, the more nearly this will be the case. In the adjoining diagram, let AB

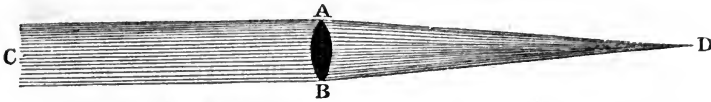

represent the section of a lens, (or object glass of a telescope,) let the parallel lines on the left represent the rays of light coming from some distant object in that direction ; the instant they impinge upon the glass, and in passing through it, they suffer refraction—that is, they are bent out of their former rectilinear path—and on leaving the lens at the opposite side, they converge to a certain point D, which is the focus of the object glass ; (in this point *all* the rays passing through a *perfectly formed* glass meet, and it is situated on the line CD, the direction of the ray which passes through the centre of the glass, the only one that continues its former course, and is called the axis of the lens;) the concentration of the rays form an image of the distant object in the focal point D, “and if a piece of ground glass, transparent paper, or a plate of glass having one surface covered with a dried film of skimmed milk, be held up at D, a person looking at it from a few inches behind would see a perfect image of the distant object formed on

the ground glass; and by steadily keeping the eye in the same position, the ground glass may be removed, and the image will appear in the same spot suspended in the air."

Now let us imagine the lens applied to the construction of a telescope, and the adjoining diagram to represent a section of it; the image of a levelling staff held at a distance, in the direction C, would be formed at the point W,

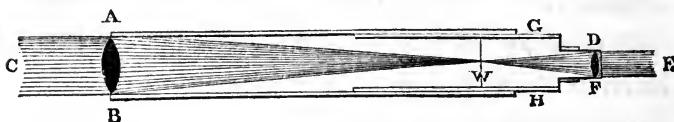

the focus of the object glass; let DF represent the eye-glass, which is fixed in a sliding tube, and together called the *eye-piece*. The eye-piece may be considered as a microscope, with which the observer magnifies the image of the object formed at W; to do this, it will readily appear to the reader that its distance from the image at W must be such as to cause its focal point to coincide therewith, making that point the common focus of the two glasses; for the purpose of effecting this, the eye-piece is made to slide either in or outwards, and the observer can tell when it is at the proper distance, for he will then obtain a perfectly distinct view of the object. The axis of the two glasses form a continued straight line CE, which in a telescope is techni-

cally termed the optical axis of the instrument, or line of collimation; this imaginary line is in levelling telescopes, the zero, from whence the readings on the staff are taken. It is therefore necessary to represent it by something tangible, that shall at the same time not interfere with the rays of light passing through the telescope to the eye; this is done by fixing across the interior of the telescope very fine wires, or threads from a spider's web, so that their intersection may not only coincide with the axis CE , but cross it precisely at W , the common focus of the two glasses, where the image of the staff (or distinct object) is formed, and therefore the wires and the staff will appear to an observer as one object, or, at least, equally distant from him. The annexed diagram shows the appearance of the wires and the staff as seen through an inverting telescope; where ab represents the horizontal wire, c and d

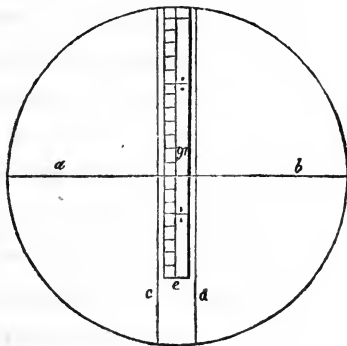

two wires placed at right angles to it, and separated so as to admit, at usual distances, the staff *e* to appear between them, by which the observer can always tell if the staff man holds it erect in a lateral direction, as before explained. The staff is represented as seen at the moment of completing an observation; the horizontal cross wire coinciding with the division .20 above 16 feet, the staff being read downwards in consequence of its apparent inversion; the reading, therefore, of such an observation, to be entered in the field-book, would be 16.20 feet.

The adjustment of the line of collimation consists in making the centre of the horizontal wire (or intersection of the wires in instruments intended for measuring angles) coincide with the optical axis of the telescope; this, when once accomplished, will, with care, keep correct for a long time, but the placing it in the common focus of the two glasses requires attention at every observation. For detailed instructions upon the former, we refer to the *Treatise on Mathematicians' Instruments, &c.*, before alluded to; but as the latter forms part of every observation, and is the source of the perplexing parallax, we shall speak of it in this place.

The cross wires are fixed to a plate, called a diaphragm, attached by screws to the slide GH, which also carries the slide DF of the

eye-piece. The point W, or focus of the object-glass, does not remain constant for terrestrial objects, but varies with every change in the distance of the staff; if it is brought closer to the instrument, the image, or focal point, will recede further from the glass, and *vice versâ*; therefore, the wires and the focus of the eye-piece must be brought to coincide with that of the object-glass by their respective slides: and first, the eye-piece should be moved in its slide till its focus coincides with the wires in the tube GH; when this is accomplished, the observer will see the wires perfectly sharp and well defined; next, motion must be given to the slide GH, by turning a milled head attached to the telescope, which gives motion to the slide by rack work; this will carry both the wires and the focus of the already adjusted eye-piece to coincide with the focus of the object-glass, on whatever part of the optical axis of the instrument it may be situated. When this is done, the adjustment of the telescope for observation will be complete, and its proof consists in the observer having at the same time a clear and well-defined image both of the staff and the cross wires, which will be the case if they seem to be *attached* to each other,—or, in other words, appear equally distant from him; and the moving about of the observer's eye does not detect any apparent displacement of the staff,

with respect to the wires. Such a displacement, or relative motion, is what is meant by *parallax*; and when it exists, it must be got rid of by a repetition of the adjustment of the glasses as above described, till the motion of the eye will no longer detect the least apparent movement, or passing and re-passing of the wires and the staff; till this is done, no correct observation can be made.

From what has been advanced on the subject of the corrections for curvature and refraction, it may be necessary, before entering upon any practical examples, to remark, that such corrections are very seldom applied in practice, the observer, by the arrangements of his operations, doing away in a great degree their injurious effects, which we will endeavour to explain.

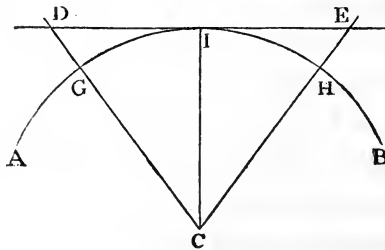

Suppose it were required to find the difference of level between any two points G and H in the adjoining figure; let AB represent a portion of the earth's surface, let C represent the centre,

and CG, CI, and CH the radii of the earth. Now a spirit-level being set up and adjusted at I, an observer looking through the telescope would see objects in the direction of the horizontal line DE only, and a staff held upright at H would be read off in the point E on the horizontal line; but this point is higher than the true level by the distance HE, which is the correction for curvature due to the distance IH; (see page 6;) if that quantity be subtracted from the reading of the staff, the remainder will show the difference of level between the points I and H. If the same process be gone through by holding a staff at G, then the difference of level between G and I will also be ascertained, which being compared with the former difference, will show how much higher one of the points G or H is above the other; but it must be evident, that if G and H be equally distant from I, the horizontal line DE, being a tangent to the surface at the middle point I, must cut the staff at D on the same level with the point E;—that is, CD is equal to CE, therefore D and E are level points, being equi-distant from the centre of the earth; and if the reading of one staff above the ground is greater than the reading of the other, the difference will at once show the variation of level between the points where the staves were held, viz., G and H; the effect of

curvature is thus removed by *simply placing the instrument midway between the station staves*. The effects of the atmospheric refraction will likewise be done away with in the same process, because it will affect both observations alike, unless under peculiar circumstances of the weather, &c., over which the observer has no control.

The above method of finding differences of level, by placing the instrument as near as possible midway between the two staves, and noting their readings, is the one adopted in practice; but as it can scarcely ever happen, on account of the extent of the work, that one placing of the instrument will complete it, a succession of similar operations must be performed, as shown in the annexed engraving.

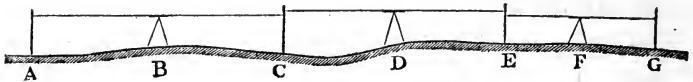

Suppose it were required to find the difference of level between the points A and G; a staff is erected at A, the instrument is set up at B, another staff at C, at the same distance from B that B is from A. The readings of the two staves are then noted; the horizontal lines connecting the staves with the instrument represent the visual ray or line of sight. The instrument then is conveyed to D, and the staff which stood at A is now removed

to E, the staff C retaining its former position, and from being the forward staff at the last observation, it is now the back staff: the readings of the two staves are again noted, and the instrument removed to F, and the staff C to the point G; the staff at E retaining the same position, now becomes in its turn the back staff, and so on to the end of the work, which may thus be extended many miles: the difference of any two of the readings will show the difference of level between the places of the back and forward staff; and the difference between the sum of the back sights and the sum of the forward sights, will give the difference of level between the extreme points: thus,

	Back Sights. <i>ft. dec.</i>	Fore Sights. <i>ft. dec.</i>
A and C . . .	10.46	11.20
C — E . . .	11.33	8.00
E — G . . .	7.42	7.91
	<hr/>	<hr/>
Sums	29.21	27.11
	27.11	
	<hr/>	
Difference of level .	2.10	
	<hr/>	

Showing that the point G is 2 feet and $\frac{10}{100}$ higher than the point A.

The foregoing process is called compound levelling. The following is an example of simple levelling, being performed at one operation, and

therefore subject to the correction for curvature and refraction to obtain a correct result.

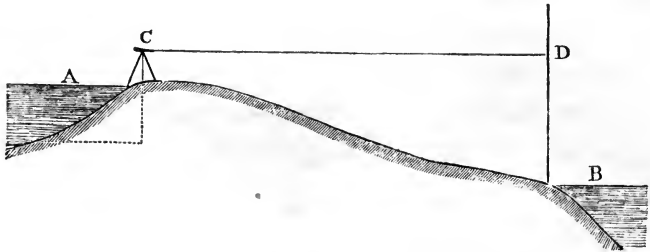

Suppose it were required to drain a pond and marsh A, by making a cut to a stream at B, a distance of thirty chains: let a level be set up at C, and directed to a staff held upright at the edge of the water at B. The horizontal line CD represents the line of sight which would cut the staff at D, the reading being 17.44 feet, the height of the instrument above the ground was 4 feet, and the depth of the pond 10 feet; therefore the difference of level between the bottom of the pond and the surface of the stream was as follows:—

	<i>ft. dec.</i>
Reading of the staff	17.44
Height of instrument	4.00
Depth of pond	10.00
Curvature and refraction for 30 chains (see table pages)	0.94
	14.94
Difference of level	2.50

PART II.

THE PRACTICE OF LEVELLING.

ON RUNNING OR CHECK LEVELS.

To present, in the clearest possible manner, the practical application of the principles of levelling, we propose describing in detail some actual operations. We shall, therefore, commence with a case of a simple kind, which will prepare the way for more complicated examples. When a section of a line of country has been completed, (for any purposes whatever,) it is in most cases necessary to check its accuracy by repetition; but in doing this, it is seldom requisite to level over precisely the same line of ground, unless there is cause to suspect its general correctness, but to follow the most convenient and nearest route, and at intervals to level to some known points on the exact line of section, which will give *their* differences of level: the points thus selected are generally what are called bench marks, and are nothing more than

marks or notches cut upon gate posts, stumps of trees, mile or boundary stones, or any similarly immoveable objects, contiguous to the line of section, and at frequent intervals. These bench marks are made by the person who takes the section in the first instance, and are sometimes previously determined upon. When the section is complete, their relative heights with regard to the base line or datum of the section become known; consequently, they may be considered as so many zero or fixed points on the line, easily recognisable, from whence any portion of the work may be levelled over again; or branch lines of level may be conducted in any direction, and the levels of such branches be comparable with those of the main line.

When, in checking the principal levels, by proceeding in the most convenient direction from bench mark to bench mark, it is found that the differences of level prove identical with those on the section, or within the limits of probable error, it may be presumed that all the intermediate heights are likewise correct: it is, however, just possible, that equal errors of an opposite kind may have been committed, when, the *sum* of each being of the same magnitude, a balance of errors would cause the extreme points to be right, whilst the intermediate levels would be incorrect; but the probability is so much

against such an occurrence, that we believe, unless there be some particular reasons for so doing, the whole exact line of a section is seldom levelled a second time for the purpose of checking the former results only.

From what has been remarked, it will appear evident that in taking running or check levels, there is no necessity for the use of the Gunter's chain, or the compass attached to the instrument, the distances and bearings having all been determined at the time the principal levels were taken.

The example we are about to give of this kind of operation is represented in the engraving plate I., which shows both the ground plan and the section. The strong black line on the plan is that of the section to be checked, and proceeds from a bridge in the town of A, in a circuitous direction along a valley, and nearly parallel to the course of a river, to a bench mark in the town of B: this originally formed a portion of a more extensive survey; and, in checking the whole of the section, it was not found convenient to level to any intermediate point on the line between A and B. We have selected this portion of the line as explanatory of our present subject: the route taken in proving the work is represented by the dotted line, and was confined to the turnpike road, that being considered the most con-

venient, because it would altogether exclude the necessity of passing through private property. Before giving the particulars of this example, we shall explain in detail the method of conducting the necessary observations.

In the first instance the staff-holder must place his staff on the bench mark from whence the levels are to commence. (In the case of our example the staff was first placed on a peculiar shaped stone on the crown of the bridge at A, which could easily be recognised from description at any future time, if ever it should be necessary to refer to this spot again; it therefore answered as a bench mark.) The surveyor must next set up his spirit-level in the most suitable spot which presents itself, from whence he can have an uninterrupted view, not only of the staff at the back station, but also for a considerable distance in the direction he wishes to carry his levels. The station selected should not in any case exceed eight or ten chains, and if it be only half that quantity, there will be less likelihood of error; for when long sights (as they are usually termed) are taken, unless both the back and forward stations are equally distant from the instrument, errors will gradually creep in upon the results, which, in a long series of levels, are liable, by their accumulation to become of serious consequence.

The proper station being determined upon,* and the tripod legs of the instrument spread out and thrust into the ground sufficiently to ensure its stability, the observer must adjust his level for observation in the following order:—First, he must draw out the eye-piece of the telescope till he sees the cross wires perfectly well defined; then, directing it to the staff, he must turn the milled-headed screw on the side of the telescope, till he can likewise distinguish with the utmost possible clearness the smallest graduations on the staff; that these two adjustments be very carefully and completely performed, is of more consequence than is generally supposed, for upon them depends the existence or non-existence of parallax. If any parallax is detected, it must be removed, or the observations will be incorrect: its existence may be detected by the observer moving his *eye* about at the same time that he is looking through the telescope at the staff; and if he sees that the cross wires do not appear to have the least motion with regard to the divisions with which they are coincident, then no parallax will exist; but if any motion appears to take place between the wires and the

* It must be borne in mind, when we thus minutely detail what may appear to the practical man as naturally obvious, that we are writing for the information of those who have never had any practice whatever.

staff, it is a proof that one or both of the foregoing adjustments have been imperfectly made.

To remedy this inconvenience, the eye-piece should first be moved to try and improve the distinct appearance of the cross wires. The observer will be greatly assisted in this operation, if he holds a sheet of white paper before the object glass, which, at the same time that it prevents other objects from attracting his attention, presents a clean white disk, or ground, for the wires to be seen upon; and when he is satisfied that they are as sharp and well defined as possible, he must repeat the movement of the milled head by the side of the telescope till he is equally satisfied of the distinct appearance of the graduations on the staff; then let him again move his eye about before the eye-glass to see if any parallax still exists, and if so, he ought to repeat the above simple operation until it is removed. We have known the parallax of a telescope to be a source of great annoyance to persons in the profession, which has led us to be thus minute upon what to some would appear very simple. We have for the like reason given an explanation of its nature, &c., at page 20.

The turning the milled head to obtain distinct vision of the staff, in the old construction of in-

struments, communicated motion to the object-glass; but in those of recent contrivance, it moves the whole of the eye end of the telescope, and with it the cross wires. In either case, the distance between the object-glass and the wires is increased to a proper extent; the modern contrivance appears to be the most approved. The adjustment of the eye-piece for distinct vision, when once made, is not likely to require alteration the whole day, unless it be accidentally deranged; but that of obtaining distinct vision of the distant staff (together with the one we shall next describe) must be performed at every station, as it varies with the distance of the staff; as explained at page 25.

Having made the above adjustments perfect, bring the spirit-bubble into the centre of its glass tube, which position it must retain unmoved in every direction of the instrument; or, in other words, the bubble must indicate a true level during the time the telescope is turned completely round horizontally on its staff head: this is accomplished by bringing the telescope successively over each pair of the parallel plate screws, and giving them motion, screwing up one while unscrewing the other to a corresponding extent; but if the telescope is supplied with a cross level, as in that contrived by Mr. Gravatt, the two bubbles, being at right angles to each other, will at once show which pair of screws

require turning, in order to produce an indication of level in both bubbles. In the Treatise on Mathematical Instruments before alluded to, there is given an ample explanation of the adjustments of levels in all their details: upon such subjects we shall once for all refer to that work.

Having adjusted the level for observation, it must be directed to the back staff, of which a clear view must be had; then note with all possible exactness the foot, and decimal fraction of a foot, with which the central part of the horizontal wire appears to be coincident, which enter in the proper column of the field or observation book. This column should be headed "Back Sight," or "Back Station," as in the example given at page 44. As soon as it is registered, look to see that the spirit-bubble has not removed from its central position, and then repeat the observation, to ensure that no mistake had been made in noting it: this should be invariably done, to guard against errors.

The back observation being made, turn the telescope round in the forward direction, and obtain a distinct view of the staff, by turning the milled head at the side of the telescope; then look at the spirit-bubble, and if it has at all changed its position, by receding towards either end of its tube, bring it back to the centre by the parallel plate-screws, as before

described; (this can be done so readily, and without moving the telescope, when a cross level is attached, and having likewise other advantages, that we recommend its universal application to spirit-levels;) then, by looking through the telescope, observe what division on the staff is intersected by the cross-wire, and enter the reading in the proper column of the field-book, which should be headed "Fore Sight," or "Fore Station." Having entered it, look to see that the bubble is still correct, and then verify the observation by noting it again, which will complete the first levels.*

It may be worth remarking, that, in setting the level up, the pointed legs should be pushed into the ground sufficiently to ensure the stability of the instrument, and likewise that the observer should move himself about the instrument, whilst taking the levels, as little as possible, taking care not to strike the legs with his feet. Caution in these matters is required, for sometimes the least movement of the person will derange the levels of the instrument, particularly on loose or elastic ground;—to do away the inconvenience arising from this source, a reflector has been contrived to fix on the top of the

* When taking levels for the formation of a section, it is necessary (unless under certain circumstances) to note the bearing of the compass needle, and to measure distances, as will be explained hereafter.

telescope tube, by which the observer can see both the staff and the reflected image of the spirit-bubble at the same time, and then he can make his observation at the instant he sees the bubble in its proper position. The foregoing description of the method of taking levels is general, and applies equally to every kind of leveling operation, with whatever additional matters may require attending to, when taking levels for the formation of a section, &c., which we shall hereafter describe.

The first levels being completed, the surveyor must take up his instrument, and, passing the man who holds the forward staff, proceed to some convenient spot to set up the instrument a second time, which, as before remarked, should not be more than eight or ten chains distant; the other man, also, who held the staff at the back station, must likewise take up a new station still further onwards in the required direction, and as nearly as possible at the same distance from the instrument as the instrument is from the staff, which has now become the back station;—it being in every case necessary, to ensure correct work, that the instrument should occupy very nearly the middle point between the staves, for reasons which will be understood by those who have perused the former part of this book. Having set the instrument up, adjust it for observation as before—viz., see that the cross-wires are dis-

tinct ; turn the milled head by the side of the telescope till the graduation on the staff is quite distinct, and no parallax exists ; and, lastly, set the spirit-bubble level in every direction of the telescope by the parallel plate-screws ; which done, note the reading on the back staff, and enter it in the book ; then examine the bubble, and again read the staff to ensure accuracy ; then turn the telescope about, and do the same for the forward station, which will complete the second level. As the third and fourth, and all the following levels, are conducted in precisely the same manner, it will be unnecessary to repeat the instructions again.

The man holding the back staff should be instructed never to move it in the least from its position till the forward observation is completed, which he can always tell by seeing the surveyor carry his level onwards. It is sometimes the practice to use one staff only, and after taking the back observation, to cause the assistant to go on and take up a position suitable for a forward station ; but besides the loss of time attendant upon such a process, if the instrument should in the interval get moved by accident, those two observations will be incorrect, unless the back sight be taken again, and this cannot be done unless the precise spot before occupied by the staff can be identified, which is sometimes uncertain. When this is the

case, no alternative is left but to go back and renew the work at the last bench mark, or known station; and if none such exist, the whole operation will probably have to be gone over again, where great accuracy is required.

The iron tripod, described at page 18, should in all cases be placed on the ground by the staff-holder, to rest the staff upon, as it insures to the observer the certainty of the staff keeping exactly the same spot when the face of it is presented to him in the two directions, forward and backward. The staff-holder should likewise be instructed to hold the staff perfectly upright, which he can himself determine in one direction, by a little plumb-weight suspended in a groove in the staff; and as the observer can tell if he holds it upright in a lateral direction, (as explained at page 17,) he should frequently look to see if he signals for him to move the upper end of the staff to the right or left, taking care not to disturb its position on the iron tripod.

We have been supposing the use of the newly introduced staves, as we do not expect that those of the former construction will hold their ground against them, they having the advantage of providing to the observer the means of noting the reading of the staff himself. If, however, from habit or otherwise, the use of the staff with the sliding vane should be pre-

ferred, the foregoing instructions equally apply; the only difference in its use is, that the observer must signal to the staff-holder to move the vane up or down on the staff, till it appears bisected by the cross-wires of his telescope; then the reading of the staff must be noted, and entered by the assistant in a temporary book carried by him for the purpose: or if he cannot be trusted to perform so important a part of the business, he must convey the staff to the observer, or wait for him to come and read it himself. It requires no comment to show the uncertainty, and loss of time, in this method of proceeding compared with the use of the newly contrived staves.

Having explained the method of taking observations for checking levels, we must refer to our example. The levels, as before stated, were taken along the turnpike road shown by the dotted line, that being the most convenient route from the town of A to the town of B, avoiding the necessity of passing through private property: the strong black line on the plan shows where the original section was taken; the section itself is represented above the plan, and is drawn to two scales; the one giving the horizontal measure, is the same as that of the plan, viz., one inch to one mile, and the vertical scale, $\frac{1}{4}$ inch to 100 feet: from this section it appears that the crown of the bridge at A, is fourteen feet

above the datum line DE of the section, and that the bench mark (a stone by the road side) at B, is 111 feet above the same datum; therefore the difference of level between the two places is $111 - 14 = 97$ feet. Now, by referring to our observation book, of which we have subjoined a copy, we make the difference of level to be 96.8 feet, differing from the original section no more than two-tenths of a foot, or 2.4 inches, a quantity that may be disregarded; the inference, therefore, to be drawn from such a coincidence in the two results, is, that the whole of the section between the points in question is correct.

Copy of Field Book, for running or check levels.

Back Sights.	Fore Sights.	Remarks.	
0.34	3.16	Back θ on B. M. on the Bridge at A.	
5.86	5.61		
4.19	4.24	Forward θ at corner of turnpike rd. leading to B.	
5.44	1.20		
4.96	3.20		
4.73	1.32		
6.10	2.00		
5.33	3.96		
5.91	1.83		
5.70	0.90		
6.02	1.21		Staff placed on Post notched for B. M.
1.21	4.00		
3.53	6.07		
3.96	5.34		
3.94	4.81		
67.22	48.85	Sums	
48.85			
18.37		Difference.	

Back Sights.	Fore Sights.	Remarks.
18.37		Brought Forward.
3.98	6.08	
4.08	4.94	
3.90	3.96	Turnpike Gate.
4.84	2.42	
1.54	5.12	
4.69	4.97	
5.04	1.60	
2.24	3.86	
7.25	1.89	
4.03	1.30	
9.54	0.19	Entrance of Sutton.
6.70	1.70	
9.40	4.06	
6.44	0.38	
11.00	0.46	
5.98	1.30	
11.12	1.78	
9.84	2.20	Top of 15th Mile Stone.
0.18	0.32	
4.72	0.10	
8.89	0.77	
10.02	0.92	
10.00	1.03	
8.58	1.19	
9.53	1.18	
9.90	0.68	
9.04	0.35	
10.00	8.52	
3.00	11.55	
3.68	0.88	
7.21	8.75	
1.99	10.48	
0.65	10.00	
4.48	10.44	
1.47	10.30	Forward θ where road enters the London road.
1.55	11.70	Forward θ on crown of bridge.
2.45	9.88	
3.78	1.04	
6.64	2.65	Forward θ on B. M. called B.
247.74	150.94	Sums.
150.94		
96.80	Difference = Diff. of level between A and B.

The back sights being greater in amount than the forward sights, it is evident that the bench mark at B was higher than the bench mark at A by the difference of the two sums.

LEVELS FOR THE FORMATION OF A SECTION.

Next to the running levels, the most simple case that can occur is, to take the levels of a line of country where the ground plan is already made, and the exact line of section determined upon, and in some instances picketed out. It is then only necessary, in addition to what is required for running levels, that the distance between the levelling staves, or between the back and fore stations, be measured. The instrument should be placed, as usual, as near as can be at an equal distance from each staff; but it is not essential that it be placed in the exact line between them, unless it should happen to prove the most advantageous position. Plate II. represents an example of this kind of work, the survey of the land having been completed, and the plan of the fields, &c., drawn: the strong black line A B was the direction determined upon as the most suitable for a portion of an intended line of rail-road, and the section was accordingly taken; a bench mark had been previously agreed upon at each extremity, (A and B,) from whence other surveyors could take up the levels, and carry them onwards in both directions.

First a staff was placed on the bench mark at A for a back station, and another staff was held up for a forward station, in the adjoining field, but exactly on the line as marked down on the plan, a copy of which the surveyor had in his possession; the instrument was then set up, as near as could be estimated, or the level of the ground would admit, at an equal distance from each staff, so as to be able to read them both; the adjustment of the instrument for observation, as described at page 35, was carefully attended to, and the reading of the staves noted. As soon as the observations were made, the distance from staff to staff was measured with a Gunter's chain, which completed the first level.

The measurement of the distance can be more conveniently performed, and with a great saving of time, by two additional assistants, who can be measuring, whilst the surveyor proceeds to direct the man who held the back staff in the last case, to take up a forward station precisely on the line as laid down on the plan. The staff which was the forward station in the last case now becomes the back station, and the instrument must be set up so as to read both stations as before, and as nearly equidistant from them as can be; by the time the instrument is adjusted, and both the staves read off, the assistant would have completed the former measurement, and be

ready to commence that of the second one : whilst this is doing, the instrument and back staff can be carried forward, and set up, &c., as before ; by a continued repetition of a similar process, the whole of the line A B was levelled.

The measuring assistant should keep a book to enter the distances in, which should be ruled in two columns, one for his distances, and the other for references to them, as *a*, *b*, *c*, &c., or the numbers 1, 2, 3, &c., placed opposite ; and if the observer makes similar notes in his book to each pair of sights, there can arise no mistake in placing the correct distances opposite the corresponding levels, when the measurer makes his return.

The following is a copy of the field-book of the example given in plate II. ; showing the manner of keeping it, and also the method adopted of reducing the levels to obtain the actual heights of each station, with regard to the starting point, for the purpose of drawing the section ; which we shall then explain.

LEVELLING FIELD BOOK.

Distance.	Rise.	Back Sight.	Fore Sight.	Fall.	Reduced Level.	REMARKS.
519	5.83	13.71	7.88	—	+ 5.83	
796	—	9.40	16.30	6.90	- 1.07	
227	—	3.87	11.71	7.84	- 8.91	
308	—	2.63	12.41	9.78	- 18.69	
508	13.67	14.62	0.95	—	- 5.02	
340	15.55	17.00	1.45	—	+ 10.53	
659	—	10.66	15.40	4.74	+ 5.79	
401	—	2.87	17.00	14.13	- 8.34	
218	—	3.40	10.32	6.92	- 15.26	
1101	3.49	5.73	2.24	—	- 11.77	
827	15.69	16.54	0.85	—	+ 3.92	
220	15.19	16.08	0.89	—	+ 19.11	
313	13.83	14.56	0.73	—	+ 32.94	
1030	—	10.36	14.06	3.70	+ 29.24	
902	8.48	9.84	1.36	—	+ 37.72	
934	2.80	9.80	7.00	—	+ 40.52	
	—	2.30	10.96	8.66	+ 31.86	Centre of road at 215 links.
376	—	10.96	14.46	3.50	+ 28.36	
257	—	2.08	15.05	12.97	+ 15.39	
228	—	1.75	16.58	14.83	+ 0.56	
412	—	1.84	17.10	15.26	- 14.70	
847	—	0.00	7.43	7.43	- 22.13	Forward O at corner of Wood.
1643	1.88	5.38	3.50	—	- 20.25	
1888	4.00	8.50	4.50	—	- 16.25	
696	3.94	5.30	1.36	—	- 12.31	
1695	0.80	10.20	9.40	—	- 11.51	
1790	6.46	6.86	0.40	—	- 5.05	
Sums.	111.61	216.24	221.29	116.66		
			216.24	111.61		
			5.05	5.05		

Dis- tance.	Rise.	Back Sight.	Fore Sight.	Fall.	Reduced Level.	REMARKS.
			5.05	5.05	- 5.05	Brought forward.
224	7.04	11.00	3.96	—	+ 1.99	
272	8.27	11.80	3.53	—	+ 10.26	
210	7.85	10.53	2.68	—	+ 18.11	Forward 0 at edge of Wood.
720	6.84	8.22	1.38	—	+ 24.95	
1110	6.56	8.76	2.20	—	+ 31.51	
	—	14.00	14.50	0.50	+ 31.01	Road at 450 links.
1039	10.18	14.50	4.32	—	+ 41.19	
511	8.14	9.14	1.00	—	+ 49.33	B above A.
	54.88	87.95	38.62	5.55		
	5.55	38.62				
	49.33	49.33				

The first column contains the measured distance from staff to staff, or from the back to the forward station, expressed in links of Gunter's chain. The two central columns, headed "Back-sight" and "Fore-sight," contain the readings of the two staves at the back and fore observations respectively. The *difference* of such readings is placed in one of the two side columns headed "Rise" or "Fall," according as the ground at the forward station is higher or lower than that at the back station. If it be highest, (or the ground rises, as it is called,) then the forward reading will be the smaller of the two; but if it be the lowest, (or the ground falls,) then the forward reading will be the greater of the two: thus, in our first reading, the back observation is 13.71, and the forward observation 7.88, their difference = 5.83 feet, which is the difference of level between the two

points, and as the forward reading was the smaller of the two, it is clear that the ground was rising at that place, and, therefore, the difference of the readings, viz., 5.83, is placed in the column of rises. In the next three successive pair of sights, the forward readings are the greatest, indicating a continued descent of the surface line, and the differences of those readings are inserted in the column of falls, viz., 6.90, 7.84, and 9.78. At the next following sight, the forward reading is again the smallest, therefore the difference 13.67 is placed in the column headed "Rise," and so on of the rest. No mistake can arise in placing the subtraction in the wrong column, as in every instance it must be placed in the column adjoining the larger quantity; thus if the fore-sight is greater than the back-sight, the resulting quantity must be placed in the column of falls, which is adjoining to that containing the reading of the fore-sight, and *vice versa*.

The adjoining column, headed "Reduced Levels," contains the absolute heights of each forward station above the datum line of the section, or a horizontal line passing through the starting point or bench mark A: these quantities, which are technically called the reduced levels, are obtained by the constant addition and subtraction of the numbers contained in the columns of "Rise" and "Fall," the former

being considered as positive, and the latter as negative quantities; thus, assuming the level of the starting point A as the datum, we have the first forward station 5.83 feet higher than the datum, therefore in the column of reduced levels it is marked + (plus): next we have a fall or negative quantity of 6.90 feet, which must be subtracted; but as it is greater than 5.83, it shows that this station is below the datum line, by the difference between 5.83 and $6.90 = 1.07$ feet, which is the depth of the second forward station *below* the datum line, and therefore is marked - (minus): the next is likewise a fall of 7.84, and as our last result was below the datum line, this additional negative quantity will take us still lower by its whole amount; it must, therefore, be added to 1.07, giving 8.91 feet for the depth of our third forward station below our datum, and is therefore entered in the column of reduced levels with a minus sign. The next is also a fall of 9.78, which, applied as the last, gives 18.69 for the depth of the fourth forward station below the datum. The ground then rises again, and we have an ascent of 13.67 feet, which will bring us nearer to our datum; and as it diminishes our depth below the datum line, it must be subtracted from the last result; thus, $18.69 - 13.67 = 5.02$ feet for the depth of the fifth forward station below the datum: we have then a rise of 15.55, which will carry us above the

datum by the amount of difference between it and 5.02, leaving 10.53 feet for the height of the sixth forward station above the datum line: the next is a fall of 4.74, which diminishes our height by that quantity, and therefore must be subtracted from 10.53, leaving 5.79 as the height of the seventh forward station above the datum.

In like manner every other pair of sights in our example was reduced, applying each difference of the back and forward readings with their proper signs, until, at the close of the work, the point B (the last forward station) was found to be 49.33 feet above the datum line, or level of the starting point A.

The reduction of levels becomes a simpler operation when the height of the bench mark (used as a starting point) above the intended datum line is known; thus, (in our example,) suppose the height of the bench mark A was 100 feet above the level of high-water Trinity mark at London Bridge, and that it was intended to assume the level of that mark as the datum line of our section; then 5.83 feet, the rise to the first forward station, must be added to 100, giving 105.83 for the height of the ground at the point *a* above datum; next, from 105.83 subtract the fall 6.90, which gives 98.93 for the height of the point *b* above datum; then, from 98.93 subtract 7.84, which gives 91.09 for the

height of c above datum ; and in like manner, by adding the quantities of rise, and subtracting those of the falls, the whole line of levels may be reduced to the line assumed as the datum.

As a proof of the accuracy of the arithmetical operation, the columns of back and fore sights should be added up, and the lesser sum subtracted from the former ; the result of the agreement with that by the reduced levels is a proof of accuracy. Likewise another proof may be obtained by adding up the contents of the column of rise and fall, and if upon taking the lesser sum from the greater, the remainder represents the same quantity as obtained by both the other operations, there can be no doubt of the correctness of the reductions of the levels, as in our example. By the reduced levels, the height of B above A is 49.33 feet. The sum of the back readings is 87.95, and that of the forward readings 38.62 ; their difference also gives 49.33 for the height of B above A ; and, lastly, the sum of the rises is 54.88, and that of the falls is 5.55, the difference giving, as before, 49.33 feet.

It is, perhaps, to be recommended, that the observer should reduce his levels as he proceeds in the field, as it will occupy but very little time, and can be frequently done while the staff man is taking a new position ; besides, the observer will frequently be able to detect by the eye if he is committing any glaring error, as,

for instance, inserting a number in the column of rises, when it ought to occupy a place in that of the falls; the surface of the ground at once reminding him that he is going down hill instead of ascending.

If the foregoing method of reducing levels be found difficult or troublesome, on account of the introduction of plus and minus signs, they can be dispensed with, as well as the columns of "Rise" and "Fall," by proceeding in the following manner. Assuming the starting point to be any even number of feet high; or, what is the same thing, assume a datum line any even number of feet below the starting point, as 100 or 1000, taking care that your choice falls upon a number greater than the number of the whole fall you are likely to experience in the operation, then from this assumed height *subtract* the reading of the forward staff, and to the remainder *add* the reading of the back staff; the result will be the height of the first forward station above the assumed datum line; then from this height subtract the next forward reading, and to the remainder add the reading of the back staff; the result will be the height of the second forward station above the assumed datum, and so on throughout the whole levelling operation. The difference between any two of the readings will be the difference of level between the corresponding points on the ground.

By way of illustration, we will reduce part of the foregoing example after this manner, and the student can then adopt whichever method he may consider the best.

Back Sight.	Fore Sight.	Reduced Levels.	Remarks.			
13.71	7.88	100.00	Assumed Datum.			
		7.88				
		92.12				
9.40	16.30	13.71				
		105.83	{ Height of 1st forward station above assumed datum.			
		16.30				
3.87	11.71	89.53				
		9.40				
		98.93	Ditto	2nd	ditto	ditto
2.63	12.41	11.71				
		87.22				
		3.87				
14.62	0.95	91.09	Ditto	3rd	ditto	ditto
		12.41				
		78.68				
17.00	1.45	2.63				
		81.31	Ditto	4th	ditto	ditto
		0.95				
10.66	15.40	80.36				
		14.62				
		94.98	Ditto	5th	ditto	ditto
2.87	17.00	1.45				
		93.53				
		17.00				
10.66	15.40	110.53	Ditto	6th	ditto	ditto
		15.40				
		95.13				
2.87	17.00	10.66				
		105.79	Ditto	7th	ditto	ditto
		17.00				
10.66	15.40	88.79				
		2.87				
		91.66	Ditto	8th	ditto	ditto

The above will, we trust, be found sufficient to make ourselves understood upon the subject of reducing levels. If, after adopting the latter mode, it should be required to reduce them to the level of the starting point as a datum, nothing more is required than to take the difference between the height thus found and that of the assumed datum: thus, in our example, subtracting 100 (the assumed datum) from the height of the first forward station, gives 5.83 for its height above the starting point: next, from 100 subtract $98.93 = 1.07$, making the second forward station that quantity below the level of the starting point, and so of the rest. But it may be done much easier after the section is made to the assumed datum, by drawing a line parallel thereto through the point A, or any other that may be determined on; thus the section may be at once adapted to any required datum line.

TO DRAW THE SECTION.

The levels being reduced, the surface line may be represented in the form of a section, as shown above the plan in plate II. The vertical and horizontal scales of a section are seldom the same, which produces a caricatured representation; the vertical scale being so much greater than the horizontal, shows the

depths of cutting and embankment required in the execution of road, railway, or canal works, with greater clearness than if both scales were equal. The plans and sections of projected works deposited with the Clerks of the Peace of counties, and in the Private Bill office, to obtain the sanction of the legislature, are mostly drawn to scales of four inches to one mile horizontal, and one hundred feet to one inch vertical; we have adopted these scales in each of our examples, except that on plate I.

To make the section of our present example, first draw the horizontal line $C D$ as the datum to which our levels were reduced, assume any point A as the starting point, then set off the measured distance from A to the first forward station $a=519$ links, (see levelling field-book, page 49;) at this point erect a perpendicular, and mark on it the height 5.83 of the first forward station, and connect the point A with this mark, and the result will show the surface line of the ground in that interval; next, from a set off the point b , the second forward station with the distance of 796 links, as given in the levelling-book, but as this point is a minus quantity, (see reduced level, page 49,) that is, below the datum line, let fall a perpendicular, and set off on it 1.07 feet, which connect by a line with the former level, and the surface line from A to

b will then be represented; then with the distance 227 set off the point *c*, and, on a perpendicular let fall therefrom, set off 8.91, which connect as before, and the section will be complete from A to *c*. In like manner, proceed with the rest of the reduced levels at the points *d*, *e*, *f*, &c., till the whole section be drawn.

In setting off on the datum line each distance separately, (as above described,) you carry forward whatever error may have been made in taking any of them from the scale. To do away with this source of error, it is better to add the measured lengths together, each to the sum of those preceding it; thus obtaining the absolute length of every station from the starting point; and by setting them off in this way, the height may be placed on the section in their correct relative situation; and should an error be committed in marking off any one point, it does not affect the rest.

The distances given in the proper column of the field-book are supposed to be horizontal distances, and, in measuring them, care should be taken that they be as nearly such as possible, (or they must afterwards be reduced thereto,) otherwise the section will be longer than it ought to be. For the purpose of assisting the surveyor in making the necessary reduction from the hypotenusal to the horizontal measure, when laying down his section, we annex the following

table, showing the reduction to be made upon each chain's length, for the following quantities of rise, as shown by the reading of the staves :—

Rise in feet for one chain.	Reduction upon one chain, in links and decimals.
1	0.01
2	0.04
3	0.11
4	0.19
5	0.29
6	0.44
7	0.56
8	0.74
9	0.94
10	1.16
11	1.40
12	1.76
13	2.01
14	2.24
15	2.61
16	2.99
17	3.39
18	3.76
19	4.23
20	4.64

The section can be referred to any other datum than the one by which it was produced; as, for instance, let it be required to refer the section, Plate II., to a datum line 100 feet below the point A; all that is required to be done is, to draw a line E F parallel to C D, at 100 feet below it; then, by drawing perpendiculars from the surface line to this new datum, as shown by the dotted lines, the transfer will be complete, as the height of any point can be

measured by the scale of the section. We need not go through a further explanation of this subject, as an inspection of our engraved examples will explain whatever further may be required.

TRIAL SECTIONS.

When a section of a line of country is required, and no ground plan of it exists, it becomes necessary for the observer to note the compass bearings of each staff every time that he takes observations of height, and also the *distance* from each *staff* to the *instrument* (not from staff to staff) must be measured. The bearings and distances will furnish him with the means of laying down the plan of his route, from which he can take the distances from station to station for the formation of his section; and if, when surveying, he has, in addition, noticed in the column of remarks, (or opposite page of his field-book purposely left blank,) the particulars of the fences and objects with which he has come in contact during the progress of his work, that is to say, their bearings, and the points where he crossed them, he will have data sufficient to make a skeleton plan, of sufficient minuteness for another person to trace the exact line of country through which the section was made.

In Plate III. is given an example of this kind. A section was required to be taken from a bench mark A to another at B, (see plan,) in the direction of the strongly marked curved line. The exact course to be followed could not be traced out in the fields for want of a ground plan, and the surveyor was left to follow the right direction as nearly as he could judge; the staves were successively placed at the points marked with small circles, and the instrument at those points marked with a cross. The compass bearings of the staves were taken at each place of the instrument, (as shown by the direction of the north point on the plan,) and the distance from the instrument to each staff measured; this afforded data for the surveyor to plot the lines he traversed in proceeding from A to B, and having noted the crossings, &c., of the fences, he was enabled to show them likewise. After this skeleton plan was drawn, the curved line was laid down as that of the section required.

It could now be seen to what degree of exactness he was furnished with the means of drawing the section, none of the points he had determined being exactly on the required line, but all of them very near to it; and as the ground in a cross direction was as nearly level as could be estimated by an accustomed eye, those heights were assumed as representing the

levels of the nearest points *a*, *b*, *c*, &c., on the proper line: this would be sufficiently correct for an approximate or trial section, and would *accurately* determine the whole difference of level between A and B; but if extreme accuracy were required, another section on the exact line must afterwards be taken. But a still nearer approximation to an accurate section might have been made in this way, if the observer had taken cross (or transverse) sections at the place of each staff, extended each way, till he was certain that he had crossed the point that would ultimately be chosen for the line of section; he could then have found the level of such point with a degree of accuracy almost sufficient for any purpose.

To draw the Section.—First rule a straight line A B (Plate III.) for the datum line of the section, and at the extremity A erect a perpendicular, on which to mark off the height of the bench mark, or starting point, above the datum, supposing such height to be known or assumed. In our example we have assumed it 100 feet, because we reduced our level as explained at page 56. If, however, we had employed the method of reduction described at page 52, the bench mark A would have been a point on the datum line, provided we had chosen to refer all our levels to that point as a standard of com-

parison. Having fixed the starting point, take with a pair of compasses the distance $A a$ on the plan, which must be equal to the distance from A to the first forward station, and mark this distance on the datum line of the section from A to a ; then erect the perpendicular $a h$, on which mark the height of the first forward station, viz., 77 feet; connect this with the bench mark A , and the surface line of section for that portion will be shown. Next, take the distance $a b$, equal that from a to the second forward station, which mark on the datum line, and set off on a perpendicular at b the height 76 feet, which, connected with the last height at a , will give that portion of the section; do the same at each of the other points, c, d, e, f, g , and the bench mark B , and the whole section will be formed. An examination of our engraving will render the whole of the process intelligible without further explanation. The roads and streams, &c., may be marked on the section by taking their distances from the nearest known points on the plan, and transferring them to the section, as the stream for instance,—the distance on the plan was taken from the point c to where the line of section crossed the stream, and transferred to the datum line from the corresponding point c , a perpendicular from thence to the surface line fixed the place of the stream on the section.

The section being drawn from a datum assumed 100 feet below the starting point, it is easy to refer it to any other datum whatever, (as before explained,) by simply drawing a parallel line through the point intended as the standard of reference, as in our engraving; the line *CD* is drawn through the first bench mark parallel to the assumed datum, *AB*, and therefore the whole section is at once referred to this new datum, showing the undulations of surface above and below it, and consequently the depth of cutting and embankment necessary to reduce the surface to a perfect level, if required for a road or railway, &c.

When a surveyor is required to level through a country in a perfectly straight line, and has not the advantage of its being picketed or poled out, his only means to keep a rectilinear course is, by ascertaining, as accurately as possible, the magnetic bearing of one extremity from the other, and work in that direction by means of a compass. We once had business of this kind, and determined the bearing of our intended line from the map of the Ordnance survey, (allowing for the variation of the needle,) and after pursuing the route thus determined, we were surprised and delighted at finding how exactly we came to our required point, convincing us (if a proof had been required) how justly the public

confidence has been placed in our national survey.

The last example we consider it necessary to give from our field operations; we recommend the student to practise the reducing and plotting, of himself, from the field notes we have sub-joined.

FIELD BOOK,

Commenced at A.

Bear- ing.	Dis- tance.	Rise.	Back.	For- ward.	Fall.	Dis- tance.	Bear- ing.	Reduced Levels.	Location.
300.20	140	—	2.15	14.97	12.82	358	120.10	—12.82	
300.40	89	—	0.50	15.14	14.64	420	120.12	—27.46	
300.15	106	—	0.54	14.12	13.58	275	120.0	—41.04	
300.10	109	—	0.83	15.31	14.48	337	120.0	—55.52	
300.0	128	—	1.49	12.15	10.66	609	120.0	—66.18	at 300 crossed fence.
300.0	592	—	5.96	10.50	4.54			—70.72	bottom of River (35 to centre.)
		6.72	10.50	3.78	—	215	120.0	—64.00	
300.30	221	7.94	8.84	0.90	—	128	119.40	—56.06	
300.30	135	8.93	9.13	0.20	—	135	120.15	—47.13	at 137 crossed fence.
300.40	150	11.10	11.27	0.17	—	134	120.20	—36.03	
296.40	155	6.05	10.47	4.42	—			—29.98	B. M. on Post corner of field.
		3.03	4.42	1.39	—	84	128.30	—26.95	
301.40	209	9.42	10.24	0.82	—	265	118.20	—17.53	
300.0	300	—	3.70	20.80	17.10			—34.63	centre of sunken Road (40.)
		5.96	20.80	14.84	—	87	119.30	—28.67	
300.0	136	—	2.66	16.25	13.59	237	120.10	—42.26	
300.30	208	—	1.66	11.84	10.18	168	120.0	—52.44	
300.20	298	2.28	5.86	3.58	—	522	120.0	—50.16	crossed fence at 10.
300.0	115	—	2.84	10.42	7.58	181	120.0	—57.74	crossed fence at 60.
300.20	87	—	1.09	8.48	7.39	593	120.0	—65.13	
300.30	302	2.00	4.43	2.43	—	88	120.20	—63.13	crossed lane at 17 and 50.
300.20	719	—	0.70	4.27	3.57	514	120.10	—66.70	
300.40	460	—	4.82	9.24	4.42			—71.12	{ centre of High Road (crossed
		6.86	9.24	2.38	—	842	120.10	—64.26	{ at 225 and 283.)
300.0	669	2.87	10.43	7.56	—	141	126.0	—61.39	closed on B.
Sums	73.16	144.57	205.96	134.55					
			144.57	73.16					
Difference of Sums			61.39	61.39					

The agreement of the three results, each giving 61.39 feet, for the whole difference of level, is a proof of the accuracy of the arithmetical operation. It will be seen by the sixth line of our field notes, that we crossed a small river or stream, and that when we turned the instrument about to observe the forward station across the river, we first directed our assistant to hold the staff in the water as near the centre as possible, and then we read off the staff as if it had been our forward station, but did not note its bearing, our only object being to obtain the level of the bed of the river, as compared with the rest of our work. The position of the river on the section could be fixed by noting the number of links we crossed it, in measuring to the next forward station, as noted in the column of remarks, where it is said to be thirty-five links from the instrument to the centre of the water. We then, without moving the instrument, directed the staff-holder to take up his forward station, and as we entered the reading of the staff in the river in the column of forward stations, we also entered it as a back station to the forward one we next observed; this was done to prevent errors in the reduction of the levels, for it is evident, that both the addition and subtraction of any quantity can produce no effect upon the result. The same method is adopted with all our bench marks on the line; also where we

wish to determine the depth of a road; or any object whatever out of the direct course of our levelling operations, as may be seen in each example we have given of keeping a levelling book.

It is very seldom the case in practice that the instrument can be placed precisely midway between the back and forward staves, on account of the inequalities of the ground, &c. By referring to our last example, it will be seen that in no one case are both the distances identical; it would appear, therefore, to be necessary to make our results perfectly correct, to apply to each observation the correction for curvature and refraction, as explained in the early pages of our book; this, however, we believe, is seldom done unless in particular cases, where the utmost possible accuracy is necessary, on account of the smallness of such correction, as may be seen by referring to our Table, page 10, where the correction for eleven chains is shown to amount to no more than $\frac{1}{100}$ of a foot. If the student will take the trouble to add up our two columns containing the back and forward distances, he will find the former to be equal 5,328 links, and the latter 6,333, their difference = 1,005, or ten chains nearly. Now the whole amount of error due to this source for the example given, is the correction for ten chains, which, according to our Table, is .0089 of a foot, a quantity that may be disregarded. If

the sum of the distances had been equal, then the sum of the errors for the back and fore observation would have likewise been equal, and no error in the extreme points would have resulted. It is very probable that in most extensive levelling operations, where care has been employed, the sum of the back and forward distances will never disagree to a great amount.

LEVELLING WITH THE THEODOLITE.

The application of the theodolite to the practice of levelling, is an operation of great simplicity. We must suppose the reader to be already acquainted with the construction and method of measuring angles with that valuable instrument; and those who have no such knowledge, we refer to the *Treatise on Mathematical Instruments* spoken of at page 13, where every particular respecting it may be found. The ordinary five-inch theodolite, of the best construction, is the one we recommend to the use of the surveyor, it being sufficiently accurate for most purposes that fall within his province, and is convenient to use on account of its portability. A larger theodolite is seldom employed, except on surveys of great extent upon trigonometrical principles, as those of the United Kingdom under the direction of the Board of Ordnance, where theodolites of three feet diameter have been employed to obtain the requisite degree of accuracy.

To use the theodolite to the common purposes of levelling, it is only necessary to set the instrument up at every spot on the line of country to be levelled, where the inclination changes, without regard to the minor inequalities of the surface, taking care that the adjustments have been carefully examined and rectified, as explained at page 16 of the book above alluded to, especially those adjustments which set the line of collimation, and the spirit-level attached to the telescope, parallel to each other. Then set the instrument level by means of the parallel plate screws, and direct an assistant to go forward with a staff, having a vane, or cross piece, fixed to it exactly at the same height from the ground as the centre of the axis of the telescope. Having gone to the forward station, the assistant must hold the staff upright, whilst the observer measures the vertical angle, which an imaginary line connecting the instrument and staff makes with the horizon; the instrument and staff should then change places, or, to save time, another staff should take the place of the instrument, and the instrument be removed to the former staff, and from thence the same angle should be taken back again, and the *mean* taken as the correct result.

The distance must then be measured, which will furnish all the data required to find the difference of level between the places of the instru-

ment and staff; this, it will appear evident, is a matter of trigonometrical calculation, the measured distance being considered as the hypothenuse of a right-angled triangle, of which the perpendicular is the difference of level. It scarcely appears necessary to give the rule for the calculation, but for the sake of uniformity we shall do.

Add together the logarithm of the measured distance, and the log-tangent of the observed angle; the sum, rejecting 10 from the index, will be the log. of the difference of level, in feet or links, &c., as the distance was measured in.

If the distance be measured with Gunter's chain, the result can at once be obtained in feet, by simply adding to the above two logarithms, the constant 9.8195439, which will be the log. of the height in feet.

In this manner, by considering the surface of every principal undulation as the hypothenuse of a right-angled triangle, the operation of levelling may be carried on with great rapidity; but it must be remarked, without pretensions to great accuracy, in fact, in that particular, the use of the spirit-level will never be superseded.

Another method of applying a theodolite to the purposes of levelling was introduced by Mr. Macneill. He caused to be constructed, by Messrs. Troughton and Simms, a more powerful instrument for the purpose. It was a combination of the level and the theodolite. He set it

up at the foot of an inclination, and sent a man on with a staff, as above described; and whilst the observer was looking through the telescope, another assistant walked along the line, holding up another staff at every rise and hollow of the intervening surface, and thereby the observer could note how much such rises and hollows were below the line of his vision. The distances from the instrument to the points where the staves were held up could then be measured, and the section drawn by simply ruling a line at the angle of elevation given by the instrument, and marking thereon the measured distances, and from such marks drawing perpendiculars of the various length indicated by the staff at its different positions: a line connecting the extremities of the perpendicular will represent the section of the surface line.

Instead of measuring the distances, Mr. Macneill had attached to the eye end of the telescope a beautifully made wire micrometer, similar to those applied to astronomical telescopes, by which he could tell with sufficient accuracy the distances required. This method of levelling, like the former by the theodolite, will give but a general approximation to the truth, depending in a great degree upon the quality of the instruments, and the care bestowed upon the operation.

PART III.

COMPUTATION OF EARTH-WORK—ROAD-MAKING— THE CLINOMETER, &c.

WE have now to show the manner of applying a section to practical purposes. If the object to be attained is the making of a rail-road, it is essential that it be formed as nearly level, and as perfectly straight, as the surface of the ground will admit of; for the nearer it approximates thereto, the more profitably will it be worked when completed, as locomotive steam-engines perform the most work with the least expense when the resistance they have to overcome is uniform and invariable. The same remarks hold with respect to a turnpike-road; but the inclinations on the latter may be made greater and more variable, being worked by animal power, which is capable of putting forth, on a sudden emergency, a greater exertion for a short time, which is not the case with elemental or mechanical power beyond limits much short of what an animal is capable of.

Sir Henry Parnell, in his valuable Treatise on Roads, recommends that a road should not

be made steeper than 1 in 35; that is, for every 35 feet in length of road surface, the difference of level will be 1 foot, that being an inclination which presents no difficulty to fast driving either in ascending or descending. But on a line of rail-road to be traversed by locomotive engines, no rate of inclination, or gradient as it is called,* should exceed 16 feet in a mile, or 1 in 330. To draw the lines of proposed surface (or gradients) upon a section, which shall be the most suitable for the purposes intended, and at the same time to be the most economical in the execution, that is to say, to have the least possible quantity of earth-work in cuttings and embankments, requires judgment and experience: no definite rules can be given for this purpose, as no two sections present the same undulating surface. There is one material point we should suggest, and which should be carefully attended to; viz., that for every piece of cutting, there should be an equal, *or rather less*, quantity of

* Mr. Macniell, in his preface to his valuable translation of Mr. Navier's little work on the "Means of Comparing the respective Advantages of different Lines of Railway," says, "I have rendered the word *peute* by *slope*, in preference to *inclination*, *inclined plane*, or *gradient*, considering the two former, though generally used, as improper expressions; and the latter, to say the least of it, as having so little to recommend it, that I hope it will have an extremely short existence in our nomenclature."

embankment. We say rather less, because every newly-formed embankment experiences a settlement to a greater or less degree, and therefore more earth will be required to raise it to a proper level. The excess of the cuttings above the embankments should never be great, otherwise the surplus would have to be disposed of in mounds, termed spoil-banks. In no case whatever should the required embankments exceed in cubical contents the quantity of cuttings; for then a serious difficulty occurs—land has to be purchased for the purpose of digging earth to supply the deficiency.

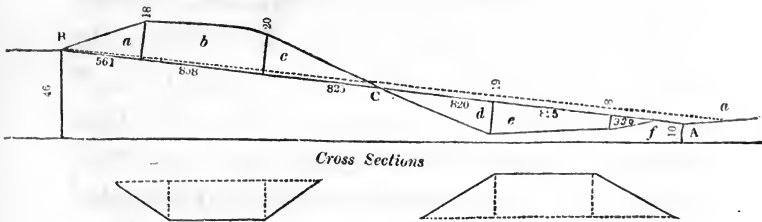

Suppose in the above cut the upper figure to represent the section of an old line of road, and that it were required, by cutting and embankment, to reduce it from its present hilly surface to one uniform rate of inclination from the point A to the point B. The lower extremity A is 10 feet above the datum line of the section, and the higher point B 46 feet above the datum; consequently, $46 - 10 = 36$ feet, the rise from A to B, and the distance 4356 feet,

which, divided by the rise, (36,) will give 1 in 121 for the rate of inclination the road may be brought to.

Upon the section draw the straight line A B, which will show the extent of cutting and embanking to be made. The number of cubic yards of earth to be removed in the cutting between the points B and C, and the cubical contents, in yards, of embankment between C and A, may then be computed in the following manner:—

Divide the quantities of cuttings and embankments, as shown upon the longitudinal section, into triangles and trapeziums, determined by the undulations of the surface lines, as shown in the above engraving, where, in the cuttings, *a* and *c* are triangles, *b* a trapezium; and in the embankments *d* and *f* are triangles, *e* a trapezium. The form of the excavation and the embankment is shown by the transverse or cross sections. Let the width of the roadway (or base of the cutting, and top of the embankment) be 50 feet, including the footpath, &c., on each side, the slope of the cutting to be $1\frac{1}{2}$ to 1, that is, $1\frac{1}{2}$ horizontal to 1 perpendicular; consequently, where the depth is twenty feet, the width of the slope at the surface will be 30 feet. The slope of the embankment to be 2 to 1, that is, for 19 feet perpendicular, the base is to be 38 feet.

With these data, the cubical quantities, as computed by the valuable tables of Mr. Macneill,* are as follows:—

Excavation 81517 yards.

Embankment 57081 yards.

24436 surplus cutting.

We have an excess of 24436 cubic yards of excavation, which is a quantity far too great. In order, therefore, to make the quantity of cutting and embankment more nearly balance each other, it would be necessary to continue the embankment beyond the point A, which would lengthen the inclination, as shown by the dotted line drawn from the point B to *a*; this dotted line would now represent the proposed surface of the road. By such means we diminish the quantity of cutting, and, at the same time, increase that of the embankments; and also by lengthening the inclination, we reduce its steepness. The alteration of the proposed surface line must be so made, that the cubical quantities of excavation and embankment are nearly equal; leaving, however, a preponderance in favour of the latter of about 10 per cent., to supply the deficiency occasioned by the consolidation and

* “ Tables for calculating the cubic quantity of earth-work in the cuttings and embankments of canals, railways, and turnpike-roads.” By John Macneill, Civil Engineer, F.R.A.S., &c.

shrinking of the earth ; and if any portion of the excess be then remaining, it may be disposed of in flattening the slopes of the embankments, when no more convenient mode presents itself.

The quantities of earth-work on a given section depend upon the arrangement and disposition of the *gradients*, or proposed surface lines ; and there is no practical consideration of more consequence to the engineer, in laying out a proposed line of surface upon a section, especially if it be of any great extent, (as the present projected lines of railway,) than the most judicious distribution of the cuttings and embankments, which should not only be nearly equal to each other in quantity, but the circumstances must be considered under which the various embankments have to be supplied, it not being alone sufficient that for every hollow on the section there should be a corresponding protuberance, but that such protuberances be advantageously situated for filling the hollows ; for otherwise the work assumes a character of difficulty, in consequence of the great additional expense of removing the earth to a considerable distance ; and if, in addition, the material has to be conveyed up an ascent, it will be more tedious in the execution.

Knowing the value of practical examples in elementary books, we shall here give the calcu-

lations of the above results in full, both by the common method, viz., *The Prismoidal Formula*, and Mr. Macneill's Tables, by which the saving of labour by the use of the Tables will be made apparent.

Prismoidal Formula.—The area of each end, added to four times the middle area, and the sum multiplied by the length divided by 6, will give the solid content. If the measures used in the calculation are yards, the result will be the content in cubic yards; but if they are feet, the result must be divided by 27, to obtain the corresponding number of yards.

CALCULATION OF THE TRIANGULAR PORTION *a*.

	Height 0	
	18	
	<hr style="width: 10%; margin: 0 auto;"/>	
	2)18	
	<hr style="width: 10%; margin: 0 auto;"/>	
Height	18	9 mean height
Slope	1.5	1.5 slope
	<hr style="width: 10%; margin: 0 auto;"/>	
	9.0	4.5
	18	9
	<hr style="width: 10%; margin: 0 auto;"/>	
Base	27.0	13.5
	50	50.0
	<hr style="width: 10%; margin: 0 auto;"/>	}
		Base (bottom of cutting, or top of embankment)
	77	63.5
Height	18	9 mean height
	<hr style="width: 10%; margin: 0 auto;"/>	
	616	571.5 middle area
	77	4
	<hr style="width: 10%; margin: 0 auto;"/>	
Area of } greater end }	1386	2286.0 = 4 times middle area
	<hr style="width: 10%; margin: 0 auto;"/>	1386.0 = area of greater end
		<hr style="width: 10%; margin: 0 auto;"/>
		3672
		561 length
		<hr style="width: 10%; margin: 0 auto;"/>
		3672
		22032
		18360
		<hr style="width: 10%; margin: 0 auto;"/>
	6)2059992	
	<hr style="width: 10%; margin: 0 auto;"/>	
	3)343332	= cub. content in feet
	<hr style="width: 10%; margin: 0 auto;"/>	
	9)114444	
	<hr style="width: 10%; margin: 0 auto;"/>	
	12716	cub. content in yards
	<hr style="width: 10%; margin: 0 auto;"/>	

COMPUTATION OF *b*.

Height 18. Area as before = 1386.

20	Height.	18	
1.5	Slope.	20	
<hr/>			
100		2)38	
20		—	
<hr/>			
		19	mean height.
30.0		1.5	slope.
50	Base.	—	
<hr/>			
		9.5	
80		19	
20	Height.	—	
<hr/>			
1600	{	28.5	
		50	Base.
<hr/>			
		78.5	
		19	mean height.
<hr/>			
		7065	
		785	
<hr/>			
		1491.5	middle area.
		4	
<hr/>			
		5966.0	= 4 times middle area.
		1386	Area of lesser end.
		1600	Area of greater end.
<hr/>			
		8952.0	
		858	= Length.
<hr/>			
		71616	
		44760	
		71616	
<hr/>			
		6)7680816	
<hr/>			
		3)1280136	= Cub. content in feet.
<hr/>			
		9) 426712	
<hr/>			
		47412	Cub. content in yards.
<hr/>			

COMPUTATION OF c .

Area 1600, as before.

20	}	Heights.
0		
<hr style="width: 10%; margin-left: 0;"/>		
2)20		
<hr style="width: 10%; margin-left: 0;"/>		
10		Mean height.
1.5		Slope.
<hr style="width: 10%; margin-left: 0;"/>		
50		
10		
<hr style="width: 10%; margin-left: 0;"/>		
15.0		
50		Base.
<hr style="width: 10%; margin-left: 0;"/>		
65		
10		Mean height.
<hr style="width: 10%; margin-left: 0;"/>		
650		= Middle area.
4		
<hr style="width: 10%; margin-left: 0;"/>		
2600		= 4 times middle area.
1600		Area of greater end.
<hr style="width: 10%; margin-left: 0;"/>		
4200		
825		= Length.
<hr style="width: 10%; margin-left: 0;"/>		
21000		
8400		
33600		
<hr style="width: 10%; margin-left: 0;"/>		
6)3465000		
<hr style="width: 10%; margin-left: 0;"/>		
3) 577500		= Cub. content in feet.
<hr style="width: 10%; margin-left: 0;"/>		
9) 192500		
<hr style="width: 10%; margin-left: 0;"/>		
21389		Cub. content in yards.
<hr style="width: 10%; margin-left: 0;"/>		
a = Cub. content	. . .	12716
b = Cub. content	. . .	47412
c = Cub. content	. . .	21389
<hr style="width: 10%; margin-left: 0;"/>		
Total cuttings	. . .	81517 Cub. yards.

COMPUTATION OF EMBANKMENT, *d.*

19	Height.	0	
2	Slope.	19	
<hr style="width: 100%;"/>			
38		2)19	
50	Base.	<hr style="width: 100%;"/>	
<hr style="width: 100%;"/>		9.5	Mean height.
88		2	Slope.
19	Height.	<hr style="width: 100%;"/>	
<hr style="width: 100%;"/>		19.0	
792		50	Base.
88		<hr style="width: 100%;"/>	
<hr style="width: 100%;"/>		69	
1672	Area.	9.5	Mean height.
<hr style="width: 100%;"/>		34 5	
		621	
<hr style="width: 100%;"/>		655.5	Middle area.
		4	
<hr style="width: 100%;"/>		2622.0	= 4 times middle area.
		1672	Area of greater end.
<hr style="width: 100%;"/>		4294	
		820	= Length.
<hr style="width: 100%;"/>		85880	
		34352	
<hr style="width: 100%;"/>		6)3521080	
		3) 586847	= Cont. in cub. feet.
<hr style="width: 100%;"/>		9) 195616	
		21735	= Cont. in cub. yards.
<hr style="width: 100%;"/>			

COMPUTATION OF *e*.

Height 8. Area, as before, 1672.

8 Height.	19	
2 Slope.	8	
16	2)27	
50 Base.	13.5	Mean height.
66	2	Slope
8 Height.	27.0	
528 = Area.	50	Base.
	77.0	
	13.5	= Mean height.
	3850	
	2310	
	770	
	1039.50	= Middle area.
	4	
	4158.0	= 4 times middle area.
	1672	= Area of greater end.
	528	= Area of lesser end.
	6358	
	825	= Length.
	31790	
	12716	
	50864	
	6)5245350	
	3) 874225	Cub. content in feet.
	9) 291408	
	32379	Cub. content in yards.

COMPUTATION OF *f*.

Area as before 528.

8	}	Heights.	
0			
<hr style="width: 10%; margin-left: 0;"/>			
2			8
<hr style="width: 10%; margin-left: 0;"/>			
4		=Mean height.	
2		=Slope.	
<hr style="width: 10%; margin-left: 0;"/>			
8			
50		=Base.	
<hr style="width: 10%; margin-left: 0;"/>			
58			
4		=Mean height.	
<hr style="width: 10%; margin-left: 0;"/>			
232		=Middle area.	
4			
<hr style="width: 10%; margin-left: 0;"/>			
928		=4 times middle area.	
528		=Area of greater end.	
<hr style="width: 10%; margin-left: 0;"/>			
1456			
330		=Length.	
<hr style="width: 10%; margin-left: 0;"/>			
43680			
4368			
<hr style="width: 10%; margin-left: 0;"/>			
6)	480480	
<hr style="width: 10%; margin-left: 0;"/>			
3)	80080	=Cub. content in feet.
<hr style="width: 10%; margin-left: 0;"/>			
9)	26693	
<hr style="width: 10%; margin-left: 0;"/>			
2966		=Cub. content in yards.	
<hr style="width: 10%; margin-left: 0;"/>			
<i>d</i>	=Cub. content	. . .	21735
<i>e</i>	=Cub. content	. . .	32379
<i>f</i>	=Cub. content	. . .	2966
<hr style="width: 10%; margin-left: 0;"/>			
Total embankment		. . .	<u>57080</u> Cubic yards.

The same quantities computed by Mr. Macniell's Tables:—

THE CUTTINGS.

COMPUTATION OF <i>a</i> .		COMPUTATION OF <i>b</i> .	
Tabular No. . . .	=22.67	Tabular No. . . .	=55.26
Length	561	Length	858
	<hr/>		<hr/>
	2267		44208
	13602		27630
	11335		44208
	<hr/>		<hr/>
Cont. of <i>a</i> in cub. yds.	=12717.87	Cont. of <i>b</i> in cub. yds.	=47413.08
	<hr/>		<hr/>

COMPUTATION OF *c*.

Tabular No.	=25.92
Length	825
	<hr/>
	12960
	5184
	20736
	<hr/>
Cont. of <i>c</i> in cub. yards . . .	=21384.00
	<hr/>

THE EMBANKMENTS.

COMPUTATION OF <i>d</i> .		COMPUTATION OF <i>e</i> .	
Tabular No. . . .	=.3519	Tabular No. . . .	=5000
Base	50	Base	50
	<hr/>		<hr/>
	17.5950		25.0000
Tabular No. . . .	+8.914	Tabular No. . . .	×14.247
	<hr/>		<hr/>
	26.509		39.247
Length	820	Length	825
	<hr/>		<hr/>
	530180		196235
	212072		78494
	<hr/>		<hr/>
Cub. content . . .	=21737.380		313976
	<hr/>	Cub. content	=32378.775
			<hr/>

COMPUTATION OF f .

Tabular No.	=.1481
Base	50
	7.4050
Tabular No.	+ 1.580
	8.985
Length	330
	269550
	26955
	2965.050
Cub. content	2965.050

RESULTS BY THE TABLES.

CUTTINGS.

$a=12717.9$
 $b=47413.1$
 $c=21384.0$

81515.0

EMBANKMENTS.

$d=21737.4$
 $e=32378.8$
 $f=2965.0$

57081.2

By comparing these results with those obtained by the former process, it will be seen that the cubical quantity of cuttings differ but two yards, and that of the embankments but one yard. The computation by the tables may be abbreviated by using but one place of decimals, which would be sufficiently accurate for practical purposes. Our object is to show the calculations in their greatest extent, which even then produces a great saving of labour, and, of course, a much greater probability of accuracy, in consequence of the fewer figures employed.

It will be seen that the calculation of the embankments by the Tables, is a longer process than that of the cuttings, the latter being done by simply multiplying a number taken from the Tables (answering to the height or depth at each end) by the length; whilst for the embankments, the tabular number is first multiplied by the base, (or width of roadway,) and to the product is added a second tabular number taken out at the same time as the first. The first series of Mr. Macneill's Tables contain the numbers corresponding to a base of 50, and a slope of $1\frac{1}{2}$ to 1, (which is the slope of the cuttings in our example.) But for a slope of 2 to 1, reference must be had to the second series of the same Tables, which are applicable to every width of base, and to slopes varying from $\frac{1}{2}$ to 1—to 3 to 1. We have adopted this example to show the calculations both by the *particular* and *general* Tables, as the first and second series of the valuable work referred to may be called.

The following is an extract from Mr. Macneill's preface to his Tables:—"All practical engineers are well aware, by experience, of the inconveniences which arise from the length of time necessary for calculating the cubic quantity of earth-work in the cuttings and embankments of canals, railways, and turnpike roads, especially when the section is of considerable extent, and

the ground very uneven. As calculations of this kind are frequently, on a short notice, required to be completed within a limited period, the consequence is, that errors are almost sure to be made, as a multiplicity of figures are necessary, though the calculations in themselves are so very simple.

“To save time in making these calculations, and insure accuracy in the results, were the principal objects I had in view in constructing the following Tables; how far I have succeeded, must be left to the decision of practical men, for whose use they were intended, and who are best able to judge of their utility.

“An advantage may arise from the use of these Tables, which I had not at first contemplated. By the common but erroneous method of calculation, the cuttings may appear to be equal to the embankments; yet, when the work is carried into effect, a large quantity of earth may be required to make up the embankments, or there may be too much earth in the cuttings for the embankments, according to the shape or figure of the section, as will be shown hereafter. Such a circumstance as this cannot take place if the following Tables be used to ascertain the cubic quantities; for as they are calculated from the prismoidal formula, they will give the true cubic quantity in any cutting or embankment;

and consequently, if the cuttings be laid down on the section to balance the embankments, they will be found in practice to do so, when the work comes to be executed.

“Contractors very frequently find that they have more earth to move than they had previously calculated upon from the section, and are, therefore, often great losers. This, in most cases, arises from erroneous calculations; for the common practice is, either to add the two extreme heights together, and to take half the sum for a mean height; or to take half the sum of the areas at each end for a mean area. Both these methods are erroneous; one makes the quantity too much—the other too little.”

SLOPES, &c.

As connected with the subject of earth-work, we may insert in this place some particulars respecting the arrangement of slopes in cuttings and embankments. They are usually expressed in terms of the height or depth of cutting, as half to one, one to one, two to one, &c., signifying that for every foot perpendicular, the cutting shall batter half a foot, one foot, two feet, &c.

The slope adopted must depend upon the nature of the material worked upon. Solid rock may be left perpendicular, whilst loose friable material,

or sand, will stand but at a very small angle with the horizon. The true criterion to judge of the proper slope to work to, is to observe, if convenient, what slope or angle the materials naturally assume when left to themselves. To determine this by measurement would be troublesome and tedious; but by the aid of a small instrument called a clinometer, the angle which any sloping surface makes with the horizon may be at once measured, and the ratio of the slope to the perpendicular, as one to one, &c., be readily deduced. As this very useful portable instrument is not generally known, we shall subjoin an engraving and description of it.

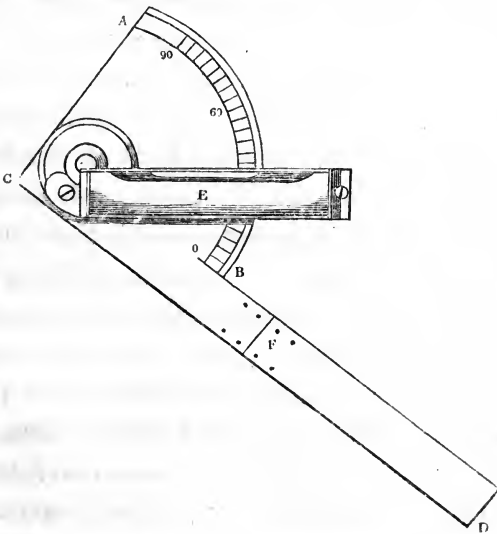

The preceding figure represents a clinometer, or, as it is called in some parts of the country, a *batter level*. It consists of a quadrant A B, of about two inches radius, attached to a flat bar C D, six inches long. The quadrant is graduated to degrees, from B towards A, and adjoining the divisions may be inserted, if required, the corresponding ratio of the slopes, one to one, &c. An index bar, E, turns upon the centre of the quadrant, and carries a spirit-level by which the index may be set truly horizontal by the hand; and whatever angle is there denoted on the quadrant, will be that of the slope required. At F is a hinge-joint, by which the bar C D may be folded up, and the instrument can then be deposited in a box of very small dimensions, and carried in the pocket without inconvenience.

To use this instrument, open the hinge-joint, and rest the edge of the bar C D on the face of the slope to be measured; then gently move the index E round its centre until the attached spirit-bubble assumes a central position in its glass tube, and the angle, indicated by the index on the graduated arc, will at once measure the inclination. The ratio of the slope to the perpendicular is represented by the natural co-tangent of the angle thus measured; but as the observer may not have at hand a table of natural co-tangents, &c., we have annexed a Table

at once showing the slopes corresponding to the various angles of inclination likely to be required.

It will appear evident, that the longer the bar C D is, the more accurate will the measure of the slope be; but there is no necessity for the instrument to be encumbered with a long bar, which would destroy its portability, because it can easily be attached by tying to the end of a long straight rod, which can be furnished by any neighbouring carpenter, and the real slope of an undulating inclined surface can then be accurately measured.

TABLE OF SLOPES.

Angle.	Slope.	Angle.	Slope.
	To one Perpendicular.		To one Perpendicular.
75.58	$\frac{1}{4}$	17 .6	$3\frac{1}{4}$
63.28	$\frac{1}{2}$	15.56	$3\frac{1}{2}$
53 .8	$\frac{3}{4}$	14.55	$3\frac{3}{4}$
45 .0	1	14 .2	4
38.40	$1\frac{1}{4}$	13.15	$4\frac{1}{4}$
33.42	$1\frac{1}{2}$	12.32	$4\frac{1}{2}$
29.44	$1\frac{3}{4}$	11.53	$4\frac{3}{4}$
26.34	2	11.19	5
23.58	$2\frac{1}{4}$	10.47	$5\frac{1}{4}$
21.48	$2\frac{1}{2}$	10.18	$5\frac{1}{2}$
19.59	$2\frac{3}{4}$	9.52	$5\frac{3}{4}$
18.26	3	9.27	6

It is very important, in fixing upon the slopes for the sides of an excavation or embankment, to approximate very nearly to the inclination at which the ground would naturally stand without

slipping; for if they be made greater than necessary, a large quantity of labour, and of the surface of the ground, will be uselessly devoted. The proper slope for each particular soil can only be determined by observation and experience. "An embankment that would stand perfectly firm, and bear the action of the weather, when formed of sand, gravel, or the debris of rocks, and other materials that do not retain water in their fissures, would not last one winter if it chiefly consisted of clay. The same remark applies with equal force to cutting, where it is made through a stratum of clay."* "A slope of 1 to 1, that is, a slope of 45° , is found sufficient for ordinary earth; for clay $1\frac{1}{2}$ to 1, or a slope of $33^\circ 42'$ with the horizon, may often be required, unless it can be mixed with open materials, to prevent water collecting in the fissures produced by its shrinkage in dry weather. In other cases, so steep a face may be left as $\frac{3}{4}$ to 1, or even $\frac{1}{2}$ to 1; and the slope that will be likely to stand may easily be judged of, by knowing the nature of the strata which will be cut through, and examining its state when exposed in the surrounding district."

At Boughton-hill, near Canterbury, there is a large cutting through London clay, which, together with the embankment at the foot of the

* Tredgold on Rail-roads, First Edition, page 117.

hill, formed of the same material, has been constantly giving way. The slopes of the embankment have been flattened from time to time, and now assume some appearance of consolidation; but the slopes of the cutting near the summit of the hill continue to slip down upon the roadway. From some cross sections we were able to take a short time since, it appears that the original slope of the cuttings was about 2 to 1, forming an angle with the horizon of $26^{\circ} 34'$; but the natural slope assumed by the soft clay where it has slipped is about 9° , or a little more than $6\frac{1}{4}$ to 1.

ON SELECTING A LINE OF COUNTRY FOR A ROAD OR RAILWAY.

The choice of a suitable line of country for the formation of a turnpike road, a rail-road, or a canal, preparatory to the levels being taken, requires both judgment and care, otherwise a fruitless expenditure of time in taking a number of trial sections may be the result, if attended with no more serious and permanent inconvenience. A person undertaking such a work, should previously devote a little time to obtain a knowledge of the country, its localities, its structure, and geological character: such knowledge will

lead to the choice of several lines of direction, which appear to the eye as equally favourable; it then becomes necessary to make such preliminary surveys as will enable the engineer to adopt the one which, under all circumstances, is likely to prove the most advantageous.

At page 113 (1st edition) of the late Mr. Tredgold's work upon Rail-roads, we find the following observations upon this subject:—"In order to facilitate the choice of a line as it regards the surface of the country, the engineer may be reminded, that even in the disposal which nature has made of hills and valleys there is much system. Those things which to the first glance of the better informed, and at all times to the ignorant, appear to be without order or arrangement, are the result of the uniform action of natural causes, and are, in reality, capable of being traced and described with less difficulty than would be expected. Where a considerable tract of country is to be surveyed, the best index to its elevations and depressions is its streams and rivers; these indicate every change of inclination, and, to the experienced eye, with considerable precision. It will also be observed, that each river has its system of valleys; and except in a few instances, where the draining is effected by the outburst of an open

stratum, a district, whose bounding ridge is easily traced, is drained by its river and system of valleys.”

“Having formed a tolerable idea of the best direction for the road, the next step must be to make a more particular survey, with a view to fix nearly the precise line. We would recommend the principal engineer to have this done by rectangular lines, as infinitely superior to surveying by triangles, in giving him an exact knowledge of the surface of the country. Perhaps, with the assistance of a diagram, we shall be able to render the advantage of this method obvious.

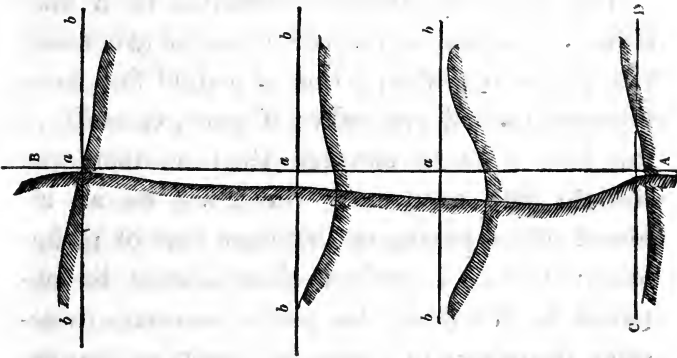

“Let A B be a portion of the intended line, and C D the breadth of the country to be included in the survey. At any suitable distances choose stations a, a, a , their distances apart depending on the changes of level, and let the

principal line A B, and also the cross lines, *b b*, *b b*, &c., be accurately levelled, and then drawn, as shown in the figure, on the plan of the line of road. If the distance *b b* is required to be considerable, perhaps an additional line in the principal direction may be necessary. The etched lines show the form of the surface at the line A B, *b b*, *b b*, &c., on the plan; and the latter being sections at right angles to A B, there is no difficulty in seeing the extent of cutting, or of embankment, that may be avoided by varying the position of the principal line. In fact, a plan of this kind, to a person familiar with sections, is better than a model of the country."

The most advantageous direction for a line, either of roadway or railroad, intended to connect two places, is evidently that of a right line, both horizontally and vertically; if one extremity of the line is more elevated than another, the straight line connecting them will be an inclined plane, having one uniform rate of inclination; but if a uniform slope cannot be obtained in the direct line, it is necessary to deviate therefrom to obtain, as nearly as the circumstances of the country will admit, such an inclined plane, or at least to obtain continued progressive rises, avoiding as much as possible the introduction of useless ascents, that is, ascending where we must descend again, and *vice*

versâ. When a line of road is encumbered with numerous and extensive useless ascents, the wasteful expenditure of power in the conveyance of goods is very great, as the number of feet actually ascended is increased many times more than is necessary, if each height, when once gained, were not lost again.

Sir Henry Parnell, in his valuable treatise on roads, gives the following instances of this kind of road-making:—"As one instance, amongst others, of the serious injury which the public sustains by this system of road-making, the road between London and Barnet may be mentioned, on which the total number of perpendicular feet that a horse must now ascend is upwards of 1300, although Barnet is only 500 feet higher than London; and, in going from Barnet to London, a horse must ascend 800 feet, although London is 500 feet lower than Barnet."

"Another instance of this defect in road engineering is observable in the line of old road across the island of Anglesea, on which a horse was obliged to ascend and descend 1283 perpendicular feet more than was found necessary by Mr. Telford, when he laid out the present new line, as shown by the annexed table;"—

	Height of summit above high water.	Total rise and fall.	Length.	
			Miles.	Yards.
Old Road	339	3540	24	428
New Road	193	2257	21	1596
Difference	146	1283	2	592

In choosing the best direction for a line of roadway, the rate of inclination which can be obtained, with a moderate outlay of capital in cuttings and embankments, is a consideration of greater importance than the mere maintaining of a direct line. For though the measured length of a circuitous route may be considerably greater than the length of a direct line, yet if the inclinations in the former case are much more favourable than those in the latter, it must be evident that more may be gained in speed, with the same expenditure of power, than is lost by the increase of distance. Thus, if two roads rise, one at the rate of 1 in 15, and the other at the rate of 1 in 35, the same expenditure of power will move a weight through fifteen feet of the one, and thirty-five feet of the other, at the same rate.

Upon the subject of the maintenance of turn-

pike-roads, we shall annex an abstract of the General Rules for Constructing and Repairing Roads, laid down by the late Mr. Telford, and which is so fully treated upon in the important work of Sir H. Parnell on Roads.

SHAPE, OR TRANSVERSE SECTION.

The roadway should be 30 feet broad; the centre should be 6 inches higher than the level of the sides, where the junction of the surface, with the sloping edge of the footpaths, or other defining bounds of the roadway, form the side channels; at 4 feet from the centre (on each side) the surface should be half an inch lower; at 9 feet, it should be 2 inches lower; and at 15 feet, its extreme edge, it should be 6 inches lower: this will give the form of a flat ellipse, which is well adapted for carrying off the water to the side channels, without making the cross section of the road too round, and allows the sun and wind to have a greater effect in evaporation, and keeping the road dry. In giving the surface one uniform curvature from side to side, the surveyor should use such a level as described at page 108.

The footpaths should be 6 feet broad, and have an inclined surface of 1 inch in a yard towards the road; its surface should not be lower than the level of the centre of the road, and the edge

should be sloped down (and covered with green sod) to meet the roadway, and form the side channel to carry off the water from the surface.

DRAINAGE.

All open main drains should be cut on the field side of the road fences, and should lead to the natural water-courses of the country; in general, they should be 3 feet deep below the bed of the road; 1 foot wide at bottom, and from 3 to 4 feet wide at top. Stone drains and culverts should also be made under the road, and continued to the open side drains, or ditches; side channels (before named) must be made on the road side, with openings of masonry into the cross drains, to prevent any water lying on the road, it being necessary, in order to preserve the surface of a road perfect, that it be kept completely dry. All land springs ought to be carried from the site of the road by under-draining.

FENCES.

“ All road fences should be kept as low as possible, never being allowed to exceed 5 feet in height, in order that they may not intercept the sun and wind, and diminish their effects in producing evaporation;” and for the same reason no trees should be allowed to grow by the side of a road; for by keeping the roads wet, they occasion

the rapid wear of the materials of which they are formed.

ROAD MATERIALS.

The hardest description of stone should always be preferred, such as basalt, granite, quartz, &c. "The whinstones, found in different parts of the United Kingdom, Guernsey granite, Mountsorrel and Hartshill stone of Leicestershire, and the pebbles of Shropshire, Staffordshire, and Warwickshire, are among the best of the stones now commonly in use. The schistus rocks being of a slaty and argillaceous structure, will make smooth roads, but they are rapidly destroyed when wet by the pressure of the wheels, and occasion great expense in scraping, and constantly laying on new coatings. Limestone is defective in the same respect. Sandstone is generally much too weak for the surface of a road; it will never make a hard one. The hardest flints are nearly as good as the best limestone; but the softer kinds are quickly crushed by the wheels of carriages, and make heavy and dirty roads. Gravel, when it consists of pebbles of the harder sorts of stones, will make a good road; but when it consists of limestone, sandstone, flint, and other weak stones, it will not; for it wears so rapidly, that the crust of a road made with it always consists of a large portion of the

earthy matter to which it is reduced, and prevents the gravel from becoming consolidated, and the road from attaining that perfect hardness it ought to possess.* When the materials are stone, they should be broken to a size of a cubical form, not exceeding 2 inches and a half in their largest dimensions, and should be capable of passing through a ring of that diameter. When it consists of gravel, the pebbles which are from 1 to $1\frac{1}{2}$ inches in size only should be used for the middle part of the road; all larger pebbles should be broken; the smaller stones may be used for the sides of the roads and the footpaths.

THE FOUNDATION AND DISPOSITION OF MATERIALS.

Before the foundation is laid, the surface on which it is to rest must be prepared, by making it level from side to side, and, if necessary, raising it so that the finished surface of the road may not be below the level of the adjoining fields. If the subsoil be wet and elastic, it must be rendered non-elastic by whatever means is best adapted to overcome the cause, as drainage, &c. The foundation should consist of a rough close-set pavement, of any kind of stones that can be most readily procured; those set in the middle

* Abridged from Sir H. Parnell on Roads, page 271.

of the road should be 7 inches in depth ; at 9 feet from the centre, 5 inches ; at 12 feet from the centre, 4 inches ; and at 15 feet, 3 inches. They should be set with their broadest faces downwards, and lengthwise across the road ; and no stone should be more than 5 inches broad on its face. “ The irregularities of the upper part of the pavement should be broken off with the hammer, and all the interstices should be filled with stone chips, firmly wedged, or packed by hand with a light hammer ; so that, when the pavement is finished, there may be a convexity of 4 inches in the breadth of 15 feet from the centre.”

“ The middle 18 feet of pavement should be coated with hard broken stones, of the form and size described under the head “ Road Materials,” to the depth of 6 inches. Four of these 6 inches to be first put on, and worked in by carriages and horses ; care being taken to rake in the ruts until the surface becomes firm and consolidated, after which the remaining 2 inches are to be put on.”

“ The paved spaces on each side of the 18 middle feet should be coated with broken stones, or well cleansed strong gravel, up to the foot-path, or other boundary of the road, so as to make the whole convexity of the road 6 inches from the centre to the sides of it ; and the whole

of the materials should be covered with a binding of an inch and a half in depth of good gravel, free from clay or earth."



The footpaths should be made with a coating of strong gravel, or small broken stones, at least 6 inches deep. The annexed engraving exhibits a section of a road constructed according to the above rules.

REPAIRING ROADS.

Towards the latter end of the autumn of each year, a road should be put into a complete state of repair, to preserve it from being broken up during the following winter, between which time and the preceding spring, all repairs, by laying on of new materials, should be done. If thin coatings be laid on at a time, and when the ground is wet, they will soon be worked into the surface without being crushed into powder.

All ruts and hollows should be filled up as soon as they appear. The side channels and drains should be continually kept clean, and free from obstruction; and all damage

they may have sustained be made good as soon as discovered.

“ A road should be scraped from time to time, so as never to have half an inch of mud upon it ; the mud should not be scraped into, or allowed to remain in, the side channels, so as to stop the running of water in them.”

“ The hedges should be kept constantly clipped and cut as low as possible, without rendering them unfit for confining cattle ; and all projecting branches of the trees in the fences should be lopped.”

In the minutes of evidence given before a Select Committee of the House of Commons on the subject of steam-carriages, we find the following paragraph as part of the evidence given by Mr. Macneill.

“ Well-made roads, formed of clean, hard, broken stone, placed on a solid foundation, are very little affected by changes of atmosphere ; weak roads, or those that are imperfectly formed of gravel, flint, or round pebbles, without a bottoming or foundation of stone pavement or concrete, are, on the contrary, much affected by changes of the weather. In the formation of such roads, and before they become bound or firm, a considerable portion of the subsoil mixes with the stone or gravel, in consequence of the necessity of putting the gravel on in thin layers ; this

mixture of earth or clay, in dry warm seasons, expands by the heat, and makes the road loose and open; the consequence is, that the stones are thrown out, and many of them are crushed and ground into dust, producing considerable wear and diminution of the materials; in wet weather, also, the clay or earth, mixed with the stones, absorbs moisture, becomes soft, and allows the stones to move and rub against each other when acted upon by the feet of horses or wheels of carriages. This attrition of the stones against each other wears them out surprisingly fast, and produces large quantities of mud, which tend to keep the road damp, and by that means increase the injury."

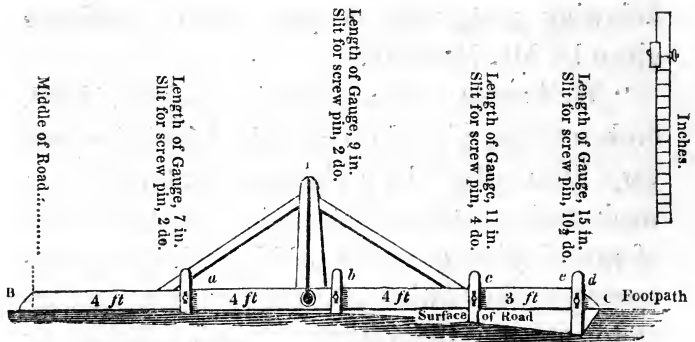

The above engraving represents the level employed by road surveyors in laying out new works. On the horizontal bar AC are placed four sliding gauges, *a*, *b*, *c*, *d*, which move in dove-tailed grooves cut in the horizontal bar, and

when adjusted to their proper depth below the bottom edge of the level, can be firmly fixed in their position by a thumb-screw. A section of this portion of the instrument, taken through the line *e, f*, is given on the right, drawn to a larger scale; the remaining parts of the instrument require no explanation.

For laying out slopes, the clinometer described at page 91 is the best instrument that can be used.

APPENDIX.*

MR. MACNEILL'S DYNAMOMETER,

OR

Road Indicator, an Instrument for ascertaining the Comparative Merit of Roads, and the State of Repair in which they are kept.

THIS Instrument is capable of being applied to several very important purposes in road engineering, amongst which are the following :—

First, It affords the means of ascertaining the exact power required to draw a carriage over any line of road.

Secondly, It can be applied to compare one line of road with another, so as to determine which of them is the best, and the exact amount of the difference, as regards horse power, both for slow and fast coaches.

Thirdly, The comparative value of different road surfaces may be determined with great exactness.

Fourthly, It affords the means of keeping a registry, in a most accurate manner, from year to year, of the state of a road, showing its improvement or deterioration, and the exact parts in which such improvement or deterioration has taken place.

Practical Examples, explanatory of the foregoing Statement.

1st.—Let it be required to determine the expense of working a four-horse coach over the line of road from — to —, at a velocity of ten miles an hour. Suppose the Instrument has been run over the road, and that it has been found that

* The Appendix is extracted from a pamphlet published by Mr. Macneill; and from the seventh report of the Commissioners of the Holyhead and Liverpool Turnpike Roads.

the average power required to draw a four-horse coach over the whole line amounts to 350 lb., and the distance equal to 12 miles. Let the average power which a horse should exert for 8 miles a day, with a velocity of 10 miles per hour, be assumed equal to 60 lb., then $60 \times 8 = 480$ lb.; raised one mile in the day,* and taking the daily expense of a horse equal to six shillings, we have 480 lb. : 6s. :: 1 lb. : .15, the expense of horse power, exerting a force of one pound over one mile. Thence $350 \times .15 \times 12$ miles = 630 pence, or £2 12s. 6d., the expense of horse power required to work a fourhorse coach per day over such a road.

2nd.—Suppose it be required to determine whether it is more expensive to work a coach over the stage, from A to B; or over the stage, from C to D; both stages being exactly ten miles, and horse-keep the same in both districts. Let the Instrument be run over both stages, and suppose the average power thus determined to be 280 lb. on the stage from A to B, and 320 lb. on the stage from C to D, the difference is $320 - 280 = 40$ lb.; and this difference will amount to $40 \times 10 \times .15 = 5$ shillings in horse power, in favour of the stage from A to B.

Again; Suppose the stage from A to B, which is ten miles in length, to be compared with the stage from E to F, which is only eight miles in length, but more hilly, or having a worse surface. Let the Instrument be run over each stage as before, and suppose the average power from E to F to be found equal to 500 lbs., whilst the average power over the stage from A to B is only 320 lbs. As this stage is ten miles in length, the expense of working over it will be $320 \times 10 \times .15 = 576$ pence; and the expense over the stage from E to F will be $500 \times 8 \times .15 = 600$ pence; from which it will be seen that less expense will be required to draw the carriage from A to B than from E to F; although the distance from E to F is two

* Stage and mail coach horses usually perform double the above work.

miles shorter than from A to B; and that the difference of expense will be $600 - 576 = 24$ pence, or two shillings per day for a four-horse coach.

3dly. Suppose it be required to determine the best surface on different parts of a road, which has been constructed on different principles, or repaired with different descriptions of road materials. Let the Instrument be run over each portion of the road, and the average power noted—also the rates of inclination as shown by the Instrument, or a spirit level—then reduce the average draught over each rate of acclivity, to what it would be if it was horizontal; the comparison of the corrected draughts will show the friction arising from the surface in each case. Thus, suppose the average draught over a portion of the road, which has been repaired with gravel, and which rises 1 in 20, to be 250 lbs.; the correction for 1 in 20 is 39.2 lbs. The friction of the surface and axles is therefore $250 - 39.2$ or 210.8 lbs. (See 7th Report of Parliamentary Commissioners of the Holyhead and Liverpool Roads—*Published by Order of the House of Commons, January, 1830.*)

In the same way suppose the draught over another portion of the road which rises 1 in 10, but which has been repaired with granite, is found to be 260 lbs. The correction for 1 in 10 is 78.4 lbs., therefore the friction of the surface, or what it would be if it was horizontal, would be $260 - 78.4$, or 181.6 lbs. only; the difference between this and the gravel surface will therefore be $210.8 - 181.6$, or 29.2 lbs., which is equal to a saving of $4\frac{1}{2}$ pence for every horse drawing over a mile of such a road, as compared with the other.

4thly. The most important and useful application of the Instrument is, perhaps that of being able to ascertain with accuracy and precision the state of any road, from time to time, as regards its surface; and the state of repair in which it has been kept.

The following table, or yearly registry of a quarter of a mile of road, will show this more clearly. The numbers in the

column represent the draught, or horse power, taken at every ten yards. Thus, in the first column of the year 1829, the draughts were in summer 20, 30, 25, &c., and in the second, or winter column of the same year, the corresponding draughts on the same identical part of the road are found to be 35, 35, 30, &c.; these columns added up, and divided by the number of observations, gives 44.5 lbs., for the mean summer draught, and 49.45 lbs. for the mean winter draughts, over this quarter of a mile. By following the same process in the following year, viz. in 1830, the mean summer draught was found to be 35.6 lbs., and the mean winter draught 40.36 lbs., showing that the road had been improved in the course of the year very considerably; and by a reference to the numbers in the columns on the same horizontal lines with each other, it will be found the improvement has been general, throughout the whole distance. In the next year, 1831, it will be seen that the average power in summer is 40.52 lbs., and in winter 46.5 lbs., which shows the road is not so good as it was in the preceding year, 1830, but better than it was in the first year, 1829. Again, in the year 1832 it is found that the average summer draught is 53.6 lbs., and the winter draught 63.18 lbs.; by comparing these numbers with any of the preceding years, it will at once be evident that the road has become worse, and by a reference to the figures in the column it will be seen that it is defective in every part as compared with the preceding years, but more especially so near the end, where the draught in summer varies from 60 to 85 lbs., and in winter from 75 to 95 lbs.; whereas, in 1830, two years before, the draughts in summer, over the same part of the road, varied from 35 to 38 lbs. only; and in winter from 46 to 40 lbs. The instrument, therefore, shows not only that the road has been getting generally worse, but it points out the particular parts—and the exact amount of deterioration; thus enabling the proper authorities to say that the road has *become*

worse, the amount of the deterioration, and the exact part of the road where such deterioration has taken place.

The public advantages to be derived from such a system of road inspection would probably be very great. It would show not only where the best plan of repairing roads has been followed, and point out where there are good and bad surveyors, but it would also show if the money of the Trust is improperly applied or wasted, on any line of road; and it will enable trustees, who let the repairs of their roads by contract, to determine whether or not the contractors have done their duty, and kept the road in the same state of repair as at first, or whether they have improved it, or suffered it to become defective.

There are many other uses to which the instrument may be applied, but the foregoing are the principal ones.

Mr. TELFORD, in his Report to the Parliamentary Commissioners of the Holyhead and Liverpool Roads, speaking of this instrument, states, "I consider Mr. Macneill's invention for practical purposes on a large scale, one of the most valuable that has been lately given to the public."

SIR HENRY PARNELL, whose zeal and practical experience in all that regards roads is well known, has repeatedly examined, and personally attended to the trial of the instrument over a great extent and variety of roads, and has given his full approbation of *its practical utility* and public advantage, as will be seen by reference to his forthcoming work on roads.

Mr. BABBAGE, the Lucasian Professor of Mathematics in the University of Cambridge, in his valuable and well known work on the Economy of Machinery and Manufactures, in considering the injury which roads sustain from various causes, states, "As connected with this subject, and as affording most valuable information upon points in which, previous to experiment, widely different opinions have been entertained,

“ the following extract is inserted from Mr. Telford’s Report
 “ on the State of the Holyhead and Liverpool Roads. The
 “ instrument employed for the comparison was invented by
 “ Mr. Macneill, and the road between London and Shrews-
 “ bury was selected for the place of experiment. The general
 “ results, when a waggon weighing 21 cwt. was used on dif-
 “ ferent sorts of roads, are as follow :—

	lbs.
1. On well-made pavement the draught is	33
2. On a broken stone surface, or old flint road	65
3. On a gravel road	147
4. On a broken stone road, upon a rough pave- ment foundation	46
5. On a broken stone surface, upon a bottom- ing of concrete, formed of Parker’s cement and gravel	46

The following statement relates to the force required to draw a coach, weighing 18 cwt., exclusive of seven passengers, up roads of various inclinations.

Inclination.	Force required at Six Miles per hour.	Force at Eight Miles per hour.	Force at Ten Miles per hour.
	lbs.	lbs.	lbs.
1 in 20	268	296	318
1 in 26	213	219	225
1 in 30	165	196	200
1 in 40	160	166	172
1 in 600	111	120	128

SPECIMEN OF THE MANNER IN WHICH IT IS PROPOSED TO KEEP A
REGISTRY OR JOURNAL OF THE STATE OF REPAIRS OF ANY ROAD.

FROM LONDON TO

First Quarter of First Mile.

Dist	1829		1830		1831		1832		1833		1834	
	Summer	Winter	Summer	Winter	Summer	Winter	Summer	Winter	Summer	Winter	Summer	Winter
10	20	35	15	30	15	32	25	40				
20	30	35	25	30	27	32	35	40				
30	25	30	20	26	22	28	30	35				
40	28	33	21	28	24	30	35	40				
50	29	33	26	28	26	30	40	50				
60	35	39	22	29	30	35	45	60				
70	30	35	22	25	24	27	35	55				
80	30	36	23	26	25	28	40	45				
90	35	40	25	35	27	37	40	50				
100	40	43	30	36	32	38	45	55				
110	45	46	35	38	37	40	50	55				
120	50	55	40	45	42	47	60	65				
130	50	54	40	44	42	46	70	75				
140	50	55	40	46	42	48	55	75				
150	55	58	50	48	52	50	60	70				
160	52	56	43	41	45	45	55	56				
170	50	54	40	45	42	48	60	70				
180	51	55	46	45	48	47	60	75				
190	53	58	45	46	47	48	65	68				
200	55	60	50	52	52	55	65	70				
210	56	60	50	55	52	58	65	75				
220	55	60	45	55	50	60	65	75				
230	50	55	45	40	48	45	60	65				
240	50	55	45	35	47	37	55	75				
250	48	50	38	40	40	44	50	60				
260	45	50	35	40	38	45	55	65				
270	40	45	30	40	35	45	45	50				
280	40	45	36	40	40	45	50	60				
290	40	45	35	35	38	40	55	60				
300	46	50	36	40	40	44	50	60				
310	44	50	32	45	40	45	55	65				
320	43	48	31	45	35	50	50	60				
330	42	50	30	40	35	45	55	60				
340	40	46	30	40	35	45	50	60				
350	45	49	38	45	40	50	46	56				
360	50	55	40	45	45	50	55	65				
370	50	56	40	46	45	50	55	70				
380	51	58	40	48	44	49	60	70				
390	52	58	46	48	50	55	50	65				
400	53	56	40	46	45	55	60	70				
410	50	55	35	45	50	60	60	75				
420	50	54	36	40	50	70	80	85				
430	55	58	38	40	60	80	80	90				
440	50	58	38	40	80	88	85	95				
Total	1958	2176	1567	1776	1783	2046	2361	2780				
Horse power.	44.5	49.45	35.6	40.36	40.52	46.5	53.6	63.18				

Description of the Instrument.

THE frame work is of wrought iron, about 2 feet 6 inches long, and 18 inches wide. In this frame a dynamometer and brass cylinder are placed; the dynamometer is connected by its arm to one side of the frame, and the cylinder is secured in the frame by trunnions, which are cast on it, and which turn in a circular hoop or belt, firmly screwed to one side of the frame, and a bar running across it. The dynamometer, or weighing machine, which forms part of the instrument, was introduced some years ago by Mr. Marriott; and as it is now so generally used in mail-coach and other offices, instead of the common steelyard, or scales requiring weights, it is needless to describe it. On my applying the weighing machine, in its simple form, to measure the draught of carriages, I found that the index vibrated so quickly, and over so large an arc of the circle, that it was impossible to observe the point indicating the force of draught; for a horse exerts his power by a succession of impulses, or strokes of his shoulders against the collar at every step he makes, and not by a constant uniform pull, as is generally supposed. To remedy this inconvenience, and do away with the vibrations, I applied a piston working in a cylinder full of oil, and connected with the dynamometer in such a manner, that when any power or force is applied to it, so as to carry round the index, the piston is at the same time moved through the fluid. The connexion of the dynamometer with the cylinder is by means of a lever working on a pivot; the arms of the lever are of unequal length; the tail-piece of the dynamometer is connected with the short arm, at a distance of 2 inches from the centre or fulcrum, by means of a pivot joint at precisely the same distance from the fulcrum; a flat bar of iron is connected with the longer arm, by a joint similar to that by which the tail-piece is connected with the short arm, so that any power or

weight applied to the bar will produce the same effect on the index, as if the power was applied directly to the tail-piece of the dynamometer ; this bar passes over a friction roller, and to it the power of the horses is applied when in use, by means of traces and a bar, as in the ordinary mode of draught. At the extremity of the long arm, the piston rod is connected by a joint similar to the others ; the piston rod, after passing through a stuffing box in the cap of the cylinder, is screwed into a piston, or circular plate of thin brass, perforated with small holes ; and out of one part of the circumference a square notch is cut, the use of which will be hereafter described.

By this construction, the resistance of the fluid to the piston, which acts at the extremity of the long arm of the lever, prevents its turning round the fulcrum to the extent it otherwise would do, when it is acted upon by any sudden impulse applied to the bar ; it will, however, move over a space proportional to the intensity of the force applied ; and if the pulls follow each other in rapid succession, the piston will move slowly out, and the index will turn round steadily and uniformly until the power is balanced by the spring of the dynamometer, at which time the index will point out on the dial very nearly the weight or power which is equivalent to the draught.

The divisions on the dial-plate of the dynamometer decrease from zero upwards, in order to compensate for the increased force which the spring exerts in proportion as it is wound up ; in consequence of this the index does not pass over equal spaces, when equal forces are applied in different states of tension of the spring ; the piston, therefore, will not pass through equal spaces in the cylinder, and the vibrations would consequently be greater in the higher numbers, because the velocity of the piston being less, its resistance through the fluid will be less, at the same time the power opposed to it is greater ; to obviate this, and make the index equally steady

on all parts of the dial, a narrow slip of brass formed into an inclined plane is soldered to the inside of the cylinder, parallel to its axis, the largest part being at that end of the cylinder towards which the piston rises when the index moves towards the greater power.

The notch which was before mentioned, as cut in the side of the piston, exactly corresponds in size with the largest part of this inclined plane, so that when the piston is at the upper end of the cylinder, the notch is completely filled up by the inclined plane; on the contrary, when the piston is at the lower end of the cylinder the notch is open; by this contrivance the aperture through which the fluid is obliged to pass as the piston moves from the lower end of the cylinder to the higher, is gradually contracted, and of course the resistance of the piston through the fluid gradually increases, and compensates the increased power of the spring, rendering the vibrations nearly uniform from the lowest to the highest power. This compensation is analogous to that by which the fusee regulates and gives uniform power to the mainspring of a watch.

Method of using the Instrument.

To preserve the instrument from warping, bending, or other injury, it is embedded in a solid block of elm, which can be screwed or clamped to any carriage; the swingletree is hooked into the eye of the draught bar; the shafts or pole of the carriage may remain in their ordinary position, but care must be taken that no part of the moving power is communicated to the carriage, except through the agency of the instrument. The draught of a carriage over any portion of ground is ascertained as follows:—One assistant walks along the side of the carriage, and observes the weight or force shown by the index on the dial; at every step he calls out the numbers, which another assistant writes down in a book; these num-

bers are then added together, and the sum divided by the number of observations that have been made, the quotient will be the mean power or draught required to draw the carriage over that portion of road. Thus, for instance, the instrument was fixed on the fore carriage of a common four-wheel waggon, and two horses attached to it; it was then drawn over the pavement in Piccadilly, between the Duke of Devonshire's house and the corner of Dover-street; the numbers given by the index were, 50 lbs, 45 lbs, 50 lbs, 50 lbs, 55 lbs, 50 lbs, 45 lbs, 40 lbs, 45 lbs, 45 lbs, 50 lbs, 45 lbs, 50 lbs, 55 lbs; the sum of these is 670 lbs, which divided by 14, the number of observations, gives $48\frac{1}{4}$ lbs. for the mean force which the horses must exert to draw the empty waggon over that part of Piccadilly pavement.

As the street in that part rises 1 foot in 156 feet, it is evident that the draught is greater than if the street were horizontal. To ascertain what it would be if it were horizontal, it is necessary to apply a correction to the draught actually shown by the instruments.

By theory, we know that the power required to retain a carriage on an inclined plane, bears the same proportion to the weight of the carriage and its load, that the height of the inclined plane bears to its length; but as the mean velocity of the matter in the wheels of a carriage is different from the velocity of the axis up the inclined plane, another correction would be necessary to get the motive power up the plane; and to persons not acquainted with the subject, the final result might appear doubtful. To obviate every objection of this kind I had a platform of timber erected, over which the same waggon that was used in the experiments on roads was drawn at different rates of inclination, and the power required to draw it up the inclined plane, with a uniform velocity of $2\frac{1}{2}$ miles per hour, in each case, was carefully determined by dead weights passing over pulleys. By this means the cor-

rection for several rates of inclination was practically ascertained, (without having recourse to theory or calculation,) and a table of correction formed for all slopes usually found on turnpike roads.

By this table, also, the correction for a slope of 1 in 156, is found to be $15\frac{1}{4}$ lbs. ; hence the horizontal draught of a waggon, over the paved surface between the Duke of Devonshire's house and Dover-street, will be $48\frac{1}{4}$, less $15\frac{1}{4}$, or 33 lbs.

In this way the surface of the whole road between London and Shrewsbury has been tried, the results of which are given in several tables.

Observations on the Use of the Instrument.

A ROAD, with a smooth and uniform surface, which is merely preserved in that state by raking, appears, to the generality of persons who travel over it, to possess all the requisites of a good and perfect road, as such persons have no means of judging of the power necessary to draw carriages over it, or the exertion required from the horses. But by means of this instrument that power can be ascertained, and consequently the comparative merit of any line of road can be determined with absolute certainty, and the experiments made with the instrument will show how very important it is to the country to have the public roads constructed and maintained on true principles.

In some instances metal rails are laid on the sides of turnpike roads, with the same undulations and rates of inclination as the road. Yet on these rail-roads a horse will usually perform as much work as five or six horses will do on the common road. This great difference in the useful effect of horses, can alone be attributed to the friction of the road surface exceeding that of the metal rails, for the friction of the axles of the waggon will be nearly similar, and the resist-

ance of gravity arising from the inclinations are, in this case, the same ; hence the superiority of the one road over the other depends entirely on the surface.

The greatest resistance which a horse has to encounter when in draught on turnpike roads, arises from gravity, which begins to act the moment the road ceases to be horizontal ; and when the inclination exceeds 1 in 30, which it often does, the additional power required is very great ; at the same time, the power of the horses is, from the same cause, much diminished. It is, therefore, the more necessary that the surface of hills should be hard, solid, and composed of such materials as the wheels of carriages cannot penetrate.

By making experiments with this instrument on every part of a turnpike road, both in summer and winter, and forming an exact table showing the resistance of the surface, and the materials with which it is repaired, a complete register would be had of the state of the road, and any improvement or falling off in the general management of the repairs of each part would be clearly perceptible, as also the amount of such improvement, or the reverse.

