

* UMass/AMHERST *



312066 0303 8324 6

Digitized by the Internet Archive
in 2010 with funding from
Boston Library Consortium Member Libraries

PUBLICATIONS OF THE JOINT EXPEDITION OF THE BRITISH
MUSEUM AND OF THE MUSEUM OF THE UNIVERSITY OF
PENNSYLVANIA TO MESOPOTAMIA

UR EXCAVATIONS

VOLUME II

THE ROYAL CEMETERY

BY

C. L. WOOLLEY

PLATES

PUBLISHED FOR THE TRUSTEES OF THE TWO MUSEUMS
BY THE AID OF A GRANT FROM THE CARNEGIE CORPORATION OF NEW YORK

1934





UR EXCAVATIONS
THE ROYAL CEMETERY



U. 10000. THE GOLD HELMET OF MES-KALAM-DUG

Scale $c. \frac{7}{10}$ (ht. 0.23 m.)

v. p. 156

M. Louise Baker pinx.

PUBLICATIONS OF THE JOINT EXPEDITION OF THE BRITISH MUSEUM AND
OF THE MUSEUM OF THE UNIVERSITY OF PENNSYLVANIA TO MESOPOTAMIA

UR EXCAVATIONS

VOLUME II

THE ROYAL CEMETERY

A REPORT ON THE PREDYNASTIC
AND SARGONID GRAVES EXCAVATED
BETWEEN 1926 AND 1931

By

C. LEONARD WOOLLEY, M.A., D.LITT.
With Chapters by the REV. E. R. BURROWS, S.J.
PROFESSOR SIR ARTHUR KEITH, M.D., F.R.S.
DR. L. LEGRAIN and DR. H. J. PLENDERLEITH

PLATES

PUBLISHED FOR
THE TRUSTEES OF THE TWO MUSEUMS
BY THE AID OF A GRANT FROM
THE CARNEGIE CORPORATION OF NEW YORK

1934

LIBRARY
UNIVERSITY OF
MASSACHUSETTS
AMHERST, MASS.

Sold in Great Britain at

THE BRITISH MUSEUM, *and by*
BERNARD QUARITCH, LTD., 11 *Grafton Street, London, W. 1*
OXFORD UNIVERSITY PRESS, *Amen House, London, E.C. 4*
KEGAN PAUL, TRENCH, TRUBNER & Co., LTD.
38 *Great Russell Street, London, W.C. 1*

and in the United States of America at

THE UNIVERSITY MUSEUM
PHILADELPHIA

PRINTED IN GREAT BRITAIN AT THE UNIVERSITY PRESS, OXFORD
BY JOHN JOHNSON, PRINTER TO THE UNIVERSITY

LIST OF PLATES

Frontispiece The Gold Helmet of Mes-kalam-dug.

SECTION A. THE EXCAVATIONS

- PLATE 1. Plan of the Temenos enclosure in the time of the Third Dynasty of Ur and the position of the Royal Tombs in relation to it.
- PLATE 2. Air photograph of the Temenos and part of the surrounding city of Ur, showing the excavated area and the site of the Royal Cemetery.
- PLATE 3. General view looking to the north-east across the cemetery to the mausoleum of Bur-Sin.
- PLATE 4. General view looking to the north-east across the cemetery to the mausoleum of Dungi.
- PLATE 5. (a) A general view of the early stages in the excavation of the cemetery; the Expedition house in the background.
(b) Part of the sheer earth sides of the excavated area, with the grave of Mes-kalam-dug in the foreground.
- PLATE 6. (a) View looking down into a corner of the excavated area and showing the walls of PG/779.
(b) The sloped approach of the royal tomb PG/779; in the background the royal tomb PG/777 and the walls of a pre-cemetery house through which was sunk the shaft of PG/580.
- PLATE 7. (a) The excavation of the cemetery; one of the earth-cut flights of steps by which the soil was carried to the surface.
(b) Excavating the upper levels at the NE. end of the cemetery area; above the workers are the foundation courses of the Temenos Wall of Nebuchadnezzar.
- PLATE 8. (a) The earth face of the pit-side with clay pots belonging to graves projecting at different levels.
(b) A general view over the cemetery, looking south-east.
- PLATE 9. (a) The earth face at the south corner of the excavated area, showing the stratification of the original rubbish-mounds.
(b) Grave PG/1845; the sloping mass of builders' rubbish tipped into the plundered shaft at the time of the building of Bur-Sin's mausoleum.
- PLATE 10. (a) One of the 'Dedication-bowls' with the ashes of sacrifice heaped above it.
(b) PG/55; the gold fillet, lead sheeting, stone vessels, cockle-shells, and beads in position in the grave.
- PLATE 11. (a) PG/333; the clay coffin and offerings beside it.
(b) PG/337; gold head ornaments in position.
- PLATE 12. (a) PG/337; the lime floor and drain for libations high up in the tomb-shaft.
(b) PG/337; the bottom of the shaft, showing clay and copper vessels and a silver belt in position.
- PLATE 13. (a) PG/337; stone vessels found above and probably belonging to the grave.
(b) PG/580; the silver belt, and with it the gold dagger in its sheath, the gold toilet-set, cylinder seal, &c., *in situ*.
- PLATE 14. (a) The impression in the soil of a wooden coffin-lid (PG/389).
(b) The impression in the soil of a coffin-lid of withies on a light wooden frame.
- PLATE 15. (a) An ordinary grave (PG/503) cleared and the remaining objects exposed.
(b) PG/505; the body exposed, lying on the white film of the decayed matting which lined the grave.
- PLATE 16. (a) PG/527; a bitumen model boat and the clay vessels in and round it.
(b) PG/622; the body in position inside the rectangle of the decayed coffin, with clay pots at its foot.

- PLATE 17. (a) PG/659; a square-ended clay larnax, partly cut away by the builders of Bur-Sin's drain.
(b) Another view of the same clay coffin showing beyond it an inhumation grave also disturbed by the drain builders.
- PLATE 18. (a) PG/671; the body and objects in position.
(b) PG/673; the body and objects in position.
- PLATE 19. (a) PG/675; the bitumen boat charged with a cargo of clay pots; traces can be seen of the coarse matting which once covered the whole.
(b) PG/627; the bitumen boat with its cargo of clay pots.
- PLATE 20. (a) PG/721; an unusually large bitumen boat built on a framework of reeds which can be seen in the photograph.
(b) PG/760; complete head-dress of a woman in position, with silver comb, hair ribbon, large ear-rings, wreath, dog-collar, &c.
- PLATE 21. (a) and (b) Two views of the inside of the grave of Mes-kalam-dug, showing the remains of the body and the gold helmet, weapons, &c., in position.
- PLATE 22. (a) PG/777; the shaft cleared down to roof-level.
(b) PG/777; the stones of the fallen roof exposed.
- PLATE 23. (a) PG/777; the SW. side of the shaft, showing the stratified rubbish through which it was cut.
(b) PG/777; the interior, showing the holes in the masonry left by the roofing-beams.
- PLATE 24. Ground-plan and section of PG/779.
- PLATE 25. (a) PG/779; view from the doorway looking up the sloped *dromos*.
(b) PG/779; view from the door looking into the interior of the tomb.
- PLATE 26. (a) PG/779; the NE. end of Chamber A, showing the vault in section.
(b) PG/779; general view looking down on the tomb.
- PLATE 27. (a) PG/779; the NE. end of Chamber A, showing the system of pendentives and the semi-corbelling of the vault.
(b) PG/779; the NE. end of Chamber C, showing the cement floor with depression for the coffin and holes perhaps for the supports of a canopy.
- PLATE 28. (a) PG/779; the NE. end of Chamber D.
(b) PG/779; the SW. end of Chamber D.
- PLATE 29. Ground-plan of PG/789, showing the position of objects and bodies.
- PLATE 30. A reconstruction of the scene in the death-pit of PG/789, based on the ground-plan, Pl. 29.
- PLATE 31. (a) PG/789; the tomb-chamber before excavation, showing the fallen brickwork and standing rings of the vault.
(b) PG/789; the tomb-chamber after excavation, showing the vault and apsidal end in burnt brick resting on walls of limestone rubble.
- PLATE 32. (a) PG/789; the standing rings of the brick vault and the NE. wall of the chamber.
(b) PG/789; the SE. wall of the tomb-chamber seen from the outside, showing the brick arch of the door, the entry blocked with brick and limestone, and the limestone wall plastered with clay; above are the remains of the brick vault.
- PLATE 33. (a) PG/789; the impression in the earth of the near wheels of the first wagon, seen from the inside.
(b) PG/789; the second wagon, seen from the outside, showing both sets of wheels and the remains of the axles. A silver bowl lies by the back axle.
- PLATE 34. (a) PG/789; the remains of the first wagon with its reins and rein-ring.
(b) PG/789; the reins and rein-ring of the first wagon *in situ*.
- PLATE 35. (a) PG/789; the skeleton of one of the oxen drawing the wagon, showing the silver ring in the nostrils.
(b) PG/789; skulls of the two oxen each with a silver ring in its nostrils.
- PLATE 36. Ground-plan of the death-pit and tomb-chamber of Queen Shub-ad (PG/800), showing the position of the objects and bodies.

- PLATE 37. (a) PG/800; head-dresses of Queen Shub-ad's women, Nos. 3 and 4.
(b) PG/800; head-dresses Nos. 5 and 6.
- PLATE 38. (a) PG/800; Queen Shub-ad's harp; the sound-box prepared for removal, the gold head attached, the upright still buried in the earth; in the foreground the head-dress of the harpist.
(b) PG/800; Queen Shub-ad's harp; the upright and the front part of the sound-box exposed.
- PLATE 39. (a) PG/800; the metal collar of one of the asses harnessed to the chariot.
(b) PG/800; the skeletons of the two asses harnessed to the chariot; in the centre the electrum and silver rein-ring (U. 10439); on the right, the skull of one of the grooms.
- PLATE 40. (a) PG/800; the wooden 'wardrobe' chest.
(b) PG/800; the south corner of the 'wardrobe' with objects in position.
- PLATE 41. (a) PG/800; the north corner of the 'wardrobe', showing the silver heads of lionesses, &c.
(b) PG/800; the NE. end of the 'wardrobe', showing gold, silver, copper, and stone vessels in position.
- PLATE 42. (a) PG/800; the inside of the tomb-chamber looking north-west, with part of the brick vault still standing.
(b) PG/800; the SE. end of the tomb-chamber showing *in situ* objects which have evidently fallen from shelves against the wall.
- PLATE 43. (a) PG/800; the interior of the tomb-chamber, the NE. wall with stone and metal vases in position.
(b) The head-dress of Queen Shub-ad *in situ*; the pins and amulets are seen by the right shoulder; the bulk of the beads covering the upper part of the body had been removed before the photograph was taken.
- PLATE 44. (a) PG/823; copper and stone vessels, beads worn at the shoulder, dagger, whetstone, and gold tweezers.
(b) PG/851; the body in position.
- PLATE 45. (a) PG/861; the interior of the wooden coffin, and its contents.
(b) PG/1043; the mass of clay vessels *in situ*.
- PLATE 46. (a) PG/1050; the outlines of the two mud-brick compartments high up in the shaft; the cross marks the layer of reeds laid over the pottery offerings.
(b) PG/1050; second stage of excavation: part of the reed layer removed to show the pottery below it.
- PLATE 47. (a) PG/1050; the second stage of excavation: another view showing the reed layer in process of removal.
(b) PG/1050; the reed layer removed and the pottery and human bones exposed.
- PLATE 48. (a) PG/1050; the plundered tomb-chamber. Under the distorted copper pot marked × was found the cylinder seal of A-kalam-dug.
(b) PG/1050; view looking straight down into the death-pit, showing the decayed condition of the bodies.
- PLATE 49. (a) PG/1054; the top level in the shaft, white calcite vase and traces of wall visible. In the foreground the intrusive burial PG/1053.
(b) PG/1054; the top level in the shaft, the outlines of a wooden box and clay vessels visible.
- PLATE 50. (a) PG/1054; the wooden box cleared to show the two gold daggers and the cylinder seal of king Mes-kalam-dug.
(b) PG/1054; the cross-wall in the top structure with the two compartments containing clay, copper, and stone vessels.
- PLATE 51. (a) PG/1054; upper level: the burial A in the south corner of the shaft.
(b) PG/1054; second stage of excavation: the layer of pottery and bones extending over the shaft.
- PLATE 52. (a) PG/1054; the burial B in the west corner of the shaft.
(b) PG/1054; the burial A in the north corner of the shaft.

- PLATE 53. (a) PG/1054; the wooden coffin of burial C, the right-hand end cut away to expose the interior.
(b) PG/1054; section in the shaft, showing clay vessels in tiers one above the other (the label is on the level of the base of the wooden coffin of Burial C shown in the upper photograph).
- PLATE 54. (a) PG/1054; the burial C, showing the interior of the coffin.
(b) PG/1054; clearing the top of the stone dome.
- PLATE 55. (a) PG/1054; the top of the stone dome, showing the holes left by the centering-beams.
(b) PG/1054; digging down to the entrance of the chamber.
- PLATE 56. (a) PG/1054; the front of the domed chamber from the courtyard, showing the opened door.
(b) PG/1054; the floor of the chamber, showing the remains of woodwork overlying the bodies (photograph taken through one of the holes in the roof).
- PLATE 57. (a) PG/1054; the interior of the domed chamber; the side wall and the springers of the dome.
(b) PG/1054; the interior of the chamber; view of the dome looking up to the cap-stone.
- PLATE 58. (a) PG/1068: 'the Grave of the Little Princess'; stone vases in position with the gold cup U. 11551 in one of them; in the centre, miniature wreaths of gold leaves and rings.
(b) PG/1069; the grave cleared, with the objects *in situ*.
- PLATE 59. (a) PG/1100; the grave as first discovered, the holes in the soil due to the decay of the upright stays of the coffin-sides; the roof is of mud bricks laid over the wooden coffin-lid.
(b) PG/1100; the grave cleared, showing along the sides the impression of the planks and upright stays of the coffin.
- PLATE 60. (a) PG/1130; jewellery in position, fillets of gold ribbon, a wreath with gold ring pendants, pin, cylinders, beads, &c.
(b) PG/1141; remains of the rectangular clay coffin, with decoration based on the upright stays of the wooden coffins.
- PLATE 61. (a) PG/1219; a rectangular ribbed clay coffin.
(b) PG/1234; the grave with gold head-dress and pots *in situ*.
- PLATE 62. (a) PG/1232; front and back wheels of the wooden wagon, with the copper pots which were inside it.
(b) PG/1232; weapons and metal vessels resting on matting on the lower floor-level in the corner of the shaft.
- PLATE 63. (a) PG/1236; the doorway; the stonework of the arched entry is faced with cement, the blocking of the doorway mud-plastered.
(b) PG/1236; the two central domed chambers and the NE. vaulted chamber, seen from above.
- PLATE 64. (a) PG/1236; the two central domed chambers and the SW. vaulted chamber, seen from above.
(b) PG/1236; the NE. chamber as discovered, with the robbers' hole at the SE. end and the rest of the roof intact.
- PLATE 65. (a) PG/1236; the SE. end of the NE. chamber, showing the white cement face on walls and floor.
(b) PG/1236; the NW. end of the NE. chamber, showing the cement floor and clay pots in position.
- PLATE 66. (a) PG/1236; the doorway from the domed chamber B to the NE. chamber A.
(b) PG/1236; chambers B, C, and D, showing at × the vertical post-hole for the frame of the communicating door.
- PLATE 67. (a) PG/1236; the doorway from chamber B to chamber C, showing the fallen lintel and, at ×, the groove for the wooden door-frame.
(b) PG/1236; chamber C, the remains of the stone dome.

- PLATE 68. (a) PG/1236; the SE. end of chamber D, showing the stone stela(?) and vessels in position.
(b) PG/1236; the NW. end of chamber D.
- PLATE 69. (a) Remains of a circular pavement of baked plano-convex bricks.
(b) PG/1237; the 'offering-table' of burnt plano-convex bricks and bitumen in the shaft.
- PLATE 70. (a) PG/1237; general view, showing men in the death-pit clearing down to the gold objects.
(b) PG/1237; excavating the lyres.
- PLATE 71. PG/1237; ground-plan of the death-pit, showing the position of the bodies.
- PLATE 72. (a) and (b) PG/1237; examples of the head-dresses of the women *in situ*.
- PLATE 73. (a) PG/1237; detailed view of the 'canopy' *in situ*.
(b) PG/1237; general view of the 'canopy' *in situ*, with remains of bodies.
- PLATE 74. (a) PG/1237; the ruined copper figures of two stags *in situ*.
(b) PG/1237; the head-dress of body No. 61 (U. 12380) *in situ*.
- PLATE 75. (a) PG/1237; the ruined copper stags and the silver 'boat lyre' *in situ*.
(b) PG/1237; the two silver lyres, the copper stags, and the big copper cauldron *in situ*.
- PLATE 76. (a) and (b) PG/1237; two views of the lyres *in situ*.
- PLATE 77. PG/1237; the goat figures *in situ*: (a) U. 12357 A, crushed flat but preserving the silhouette of the figure; (b) U. 12357 B, the upper part, broken away from the lower, preserving the relative position and spacing of the branches.
- PLATE 78. (a) PG/1422; the collapsed wooden lid of the coffin.
(b) PG/1422; the interior of the wooden coffin, showing gold bracelets, fillets on the skull, vases, dagger, &c.
- PLATE 79. (a) PG/1548; the bones and objects in position.
(b) PG/1578; larnax grave containing a partially burnt body, intrusive in PG/1551.
- PLATE 80. (a) PG/1618; loose blocks of limestone pulled up from the tomb-chamber of PG/1648 and re-used.
(b) PG/1618; the principal body in position, with gold fillet, gold dagger, &c.
- PLATE 81. (a) PG/1631; the interior of the plundered stone chamber.
(b) PG/1648; the interior of the stone chamber.
- PLATE 82. (a) PG/1847; the shaft in course of excavation, showing the constructions at different levels.
(b) PG/1847; diagrammatic section of the shaft.
- PLATE 83. (a) PG/1847; the niches and altars on the upper and lower floor-levels.
(b) PG/1847; the two niches and altars, the walled enclosure, and fire-places in the floor.
- PLATE 84. (a) PG/1847; the lowest level; below the wall of the enclosure the bitumen boat, the reed table, and the coffin pit.
(b) PG/1847; the table, part of the smooth clay plaster removed to expose the reeds.
- PLATE 85. (a), (b) PG/1847; two views of the coffin of burial S.
- PLATE 86. (a) PG/1847; detail of the coffin of burial S, showing the string binding of the reeds.
(b) PG/1851; bitumen boat, showing the skeleton of withies on which the bitumen was plastered.

SECTION B. OBJECTS

- PLATE 87. 'The Ram caught in a Thicket', U. 12357 A, one of the two goat statuettes from the Great Death-pit: three-quarter view.
- PLATE 88. The goat statuette, U. 12357 A: front and back views.
- PLATE 89. The goat statuette, U. 12357 B: front view.
- PLATE 90. (a) The goat statuette, U. 12357 A, flattened by the pressure of the soil.
(b) The fleece of the goat statuette, U. 12357 A, from the inside, showing the attachment of the shell to the bitumen.
(c) The Standard, before cleaning.
- PLATE 91. The Standard, U. 11164: the 'Peace' panel.

- PLATE 92. The Standard, U. 11164: the 'War' panel.
- PLATE 93. The Standard, U. 11164: the end panels.
- PLATE 94. Reconstruction of the mosaic on the wardrobe of Queen Shub-ad, U. 10441-2.
- PLATE 95. Gaming-boards. (a) U. 10478, from Queen Shub-ad's tomb; (b) U. 9000, from PG/513; three dice, U. 10478; a set of gaming-pieces, U. 8632.
- PLATE 96. Gaming-board U. 10557, from PG/789, and a complete set of gaming-pieces in shell and shale found inside it.
- PLATE 97. Part of an inlaid gaming-board, U. 11162, from PG/779.
- PLATE 98. (a) Shell gaming-pieces and (b) a complete set from the tomb of Queen Shub-ad, U. 10478.
- PLATE 99. (a) Shell carvings U. 9905, U. 9906, U. 9907, from PG/580.
(b) Parts of an inlaid gaming-board, U. 9776, from PG/580.
- PLATE 100. Engraved shell plaques from various graves.
- PLATE 101. (a) U. 8191 and U. 8198; shells cut as lamps and carved with heads of birds.
(b) U. 10437; mother-of-pearl handle from Queen Shub-ad's tomb.
- PLATE 102. (a) U. 8313; bird of shell and mosaic.
(b) U. 7900; shell plaque engraved with scene of a priest pouring libations.
- PLATE 103. (a) Mother-of-pearl toilet-box, U. 14483 A. (b) Queen Shub-ad's inlaid toilet-box lid, U. 10436. (c) Engraved shell plaques U. 9112. (d), (e) Shell handles, U. 10988 and U. 8935.
- PLATE 104. Engraved shell plaques from the sound-boxes of lyres, U. 10577, U. 10412, U. 12353, U. 12354.
- PLATE 105. Engraved shell plaques with mythological (?) scenes from the sound-box of the lyre U. 10556 in PG/789.
- PLATE 106. (a) The lyre, U. 10556, *in situ*, showing the impression in the soil of the sound-box and back upright PG/789.
(b) The front of the lyre U. 10556 as removed, preparatory to cleaning.
- PLATE 107. The gold head of a bull with lapis-lazuli beard from the sound-box of the lyre U. 10556. Restored.
- PLATE 108. (a) Queen Shub-ad's harp *in situ*, PG/800, showing the shell plaques and part of the mosaic border of the sound-box attached together and to the gold head.
(b) The front of Queen Shub-ad's harp, U. 10412, as restored.
- PLATE 109. U. 10412, Queen Shub-ad's harp, restored.
- PLATE 110. U. 10412, Queen Shub-ad's harp: detail of the sound-box.
- PLATE 111. U. 12354, silver lyre from the Great Death-pit, PG/1237.
- PLATE 112. U. 12355, silver stag lyre from the Great Death-pit.
- PLATE 113. (a) U. 12356, copper statue of stags from the Great Death-pit.
(b) U. 12353, the mosaic border of the gold lyre's sound-box as removed from the soil.
- PLATE 114. U. 12353, the gold lyre from the Great Death-pit.
- PLATE 115. U. 12353, the golden bull's head from the gold lyre.
- PLATE 116. U. 12435, copper bull's head and shell plaques from a lyre, PG/1332.
- PLATE 117. (a) U. 12435, copper head of a bull from a lyre, PG/1332.
(b) U. 12353, gold head of a bull from the gold lyre.
- PLATE 118. (a) PG/1151; the plaster cast of the wooden lyre, U. 12351, *in situ* after the earth had been cut away on one side; the strings of the lyre visible in the soil.
(b) The plaster cast of the lyre, U. 12351, removed from the soil, showing the better-preserved face.
- PLATE 119. (a), (b) U. 12351; the copper bull's head and engraved shell plaque from the plaster lyre.
- PLATE 120. (a) U. 10916; silver head of a cow from Queen Shub-ad's tomb.
(b) U. 10577; copper head of a bull from a lyre in PG/789.

- PLATE 121. (a), (b) Two views of the copper head of a horned demon, U. 11798.
- PLATE 122. Reconstruction of the sledge-chariot of Queen Shub-ad, U. 10438.
- PLATE 123. (a) The body of the reconstructed chariot of Queen Shub-ad seen from behind.
(b) The gold lions' heads from the side panel of Queen Shub-ad's chariot in position in the ground.
- PLATE 124. U. 10438: the top panel of Queen Shub-ad's chariot restored.
- PLATE 125. U. 10438: small gold heads of bulls and lions from the top bar of Queen Shub-ad's chariot.
- PLATE 126. U. 10438, Queen Shub-ad's chariot:
(a) A gold lion's head from the side panel.
(b) Silver lion's head and mosaic (as taken from the soil) from the bar joining the runners.
(c) Two silver heads of lionesses from the front of the chariot.
- PLATE 127. (a) U. 10465, silver head of a lioness from Queen Shub-ad's tomb.
(b) U. 10933, &c., Queen Shub-ad's head-dress, side view.
- PLATE 128. Queen Shub-ad's head-dress, U. 10933, &c.
- PLATE 129. Ornaments from Queen Shub-ad's head-dress.
- PLATE 130. (a) U. 10937; the gold 'comb' or head-ornament of Queen Shub-ad.
(b) The beads which covered the upper part of the body of Queen Shub-ad put together as a cloak, U. 10975, &c.
- PLATE 131. Examples of beads from Queen Shub-ad's cloak.
- PLATE 132. Specimens of beads.
- PLATE 133. Specimens of beads and pendants.
- PLATE 134. Specimens of beads and pendants.
- PLATE 135. Examples of 'wreaths'.
- PLATE 136. Example of the silver 'comb' head-dress.
- PLATE 137. (a) U. 8212, silver head ornament.
(b) U. 9340, gold toilet-set.
(c) Cockle-shells, real and of silver, containing paint.
- PLATE 138. Gold finger-rings, ear-rings, filigree disks, and bead.
- PLATE 139. U. 8173, gold fillet with stamped decoration of men and animals.
- PLATE 140. U. 10948, the diadem of Queen Shub-ad.
- PLATE 141. U. 10948, gold ornaments from the diadem of Queen Shub-ad.
- PLATE 142. Amulets in gold and stone and shell.
- PLATE 143. Amulets.
- PLATE 144. U. 12380; head-dress of a woman (body 61) from the Great Death-pit.
- PLATE 145. Jewellery from the body 51 in the Great Death-pit.
- PLATE 146. (a) U. 9657, gold filigree bead.
(b) U. 12467, gold ear-rings of unusual type.
(c) U. 13788-96, Gold objects from PG/1618.
- PLATE 147. (a) U. 17912; objects from PG/1850, burial 9.
(b) U. 17813; objects from PG/1847, burial R.
- PLATE 148. (a) Skull of a soldier wearing a copper helmet, PG/789.
(b) A woman's skull with its head-dress of wreaths, beads, &c., waxed and removed in order, PG/1237.
- PLATE 149. (a) Skulls of two of the soldiers wearing copper helmets photographed *in situ* in the *dromos* of PG/789.
(b) U. 10411; gold spear-heads with gold and silver binding from the shafts and a gold butt with copper fork for the throwing-string, PG/789.
- PLATE 150. (a), (b) The Gold Helmet of Mes-kalam-dug, U. 10000: front and back views.

- PLATE 151. U. 9361, the gold dagger, and U. 9340, the gold toilet-case, from PG/580.
- PLATE 152. U. 10014, a gold dagger, and U. 10020, a dagger with gold-plated handle, from the grave of Mes-kalam-dug.
- PLATE 153. (a) U. 12442, sceptre of gold and mosaic.
(b) Gold- and silver-headed spears, U. 10411, U. 10472.
(c) U. 9333, 9335, axe with gold-bound handle.
- PLATE 154. (a) Spear and harpoon heads, from Mes-kalam-dug's grave.
(b) Dagger, pin, and rings from Mes-kalam-dug's grave.
- PLATE 155. Weapons and whetstone from Mes-kalam-dug's grave.
- PLATE 156. (a) U. 10018, electrum double axe from Mes-kalam-dug's grave.
(b) U. 9255, ostrich shell with mosaic incrustation.
- PLATE 157. (a) U. 10553, a gold-mounted dagger.
(b) Gold dagger-blades, U. 11512-13.
(c) Gold tumbler, U. 11902.
- PLATE 158. (a) U. 10478, dice of lapis and gold, and of shell and lapis.
(b) Gold saw and chisels.
- PLATE 159. (a) U. 8598, a silver pin perhaps intended to hold feathers.
(b) U. 8002, a chain of gold and lapis-lazuli, and U. 9362, a silver toilet-set.
(c) Two electrum bowls, U. 10013 and U. 10034, from the grave of Mes-kalam-dug.
- PLATE 160. Gold Vessels.
- PLATE 161. Gold Vessels.
- PLATE 162. Gold Vessels.
- PLATE 163. Gold Vessels.
- PLATE 164. Gold Vessels.
- PLATE 165. Gold objects, and obsidian bowl, U. 10488.
- PLATE 166. U. 10439, the silver and electrum rein-ring of Queen Shub-ad, with donkey 'mascot'.
- PLATE 167. (a) U. 10551, the silver rein-ring with bull 'mascot' from PG/789.
(b) U. 11794, silver bowl with embossed design of wild goats.
- PLATE 168. U. 8103, silver head of an antelope, before and after cleaning.
- PLATE 169. (a) U. 10566, the silver model boat from the tomb-chamber, PG/789.
(b) U. 10475, copper plaque with embossed decoration, perhaps from a shield, PG/789.
- PLATE 170. (a) U. 11154, gold copy of an ostrich shell with mosaic incrustation.
(b) U. 9364, silver lamp (?).
- PLATE 171. Silver Vessels.
- PLATE 172. Silver Vessels.
- PLATE 173. Silver Vessels.
- PLATE 174. (a) U. 10517, cup of lapis-lazuli.
(b) U. 10552, whetstone of lapis-lazuli on a gold ring.
(c) U. 10480, bowl of green calcite.
- PLATE 175. U. 10882, jar of veined calcite.
- PLATE 176. Stone Vessels.
- PLATE 177. Stone Vessels.
- PLATE 178. Stone Vessels.
- PLATE 179. Stone Vases.
- PLATE 180. (a) Stone Vessels.
(b) Clay offering-table.
(c) Limestone offering-table.
- PLATE 181. U. 8557, fragment of a limestone relief, and an almost identical relief from Khafaje.
- PLATE 182. Two lamps of white calcite with reliefs of human-headed bulls, U. 10746 and U. 11795.

- PLATE 183. U. 11678, carved limestone mace-head.
- PLATE 184. Copper Vessels.
- PLATE 185. Copper Vessels.
- PLATE 186. U. 11838, painted clay pot of Susa II style.
- PLATE 187. (a) U. 10747, clay vase handle in the form of a woman.
(b) U. 10183, clay vase with decorated handle recalling the human type.
- PLATE 188. (a) U. 14461, clay zoomorphic vase, or toy, in the form of a cow on wheels.
(b) Imprint of a circular basket.
- PLATE 189. (a) Bronze spears with owners' marks.
(b) Silver pin with human hand as head, U. 8014.
- PLATE 190. (a), (b), (c) Marks on gold and bronze weapons.
(d), (e) Inscriptions on metal bowls, U. 7994, 10081.
- PLATE 191. Inscriptions from the Cemetery.
- PLATES 192-216. Impressions of cylinder seals.
- PLATE 217. Embossed patterns on silver and gold, U. 11794 and U. 12457.
- PLATE 218. Head-dresses as worn, helmets and varia.
- PLATE 219. Types of ear-rings and fillets; amulets, brooches, &c.
- PLATE 220. Specimens of bead-stringing, &c.
- PLATE 221. Gaming-pieces, stone and clay varia.
- PLATE 222. Woodwork.
- PLATE 223. Types of cast bronze axes.
- PLATE 224. Unusual axe types, &c.
- PLATE 225. Types of hammered copper axes.
- PLATE 226. Types of hammered copper axes; bows; metal holdfasts, &c.
- PLATE 227. Types of spears and arrows.
- PLATE 228. Types of knives and daggers.
- PLATE 229. Types of saws, adzes, chisels, and tools.
- PLATE 230. Types of tools, &c.
- PLATE 231. Types of pins, needles, and toilet instruments.
- PLATES 232-40. Types of Metal Vessels.
- PLATES 241-50. Types of Stone Vessels.
- PLATES 251-67. Types of Clay Vessels.
- PLATES 268, 269. Skulls of Queen Shub-ad and of Mes-kalam-dug.
- PLATE 270. Section showing the strata on the face of the cutting at the SW. end of the cemetery excavations.
- PLATE 271. Section across the cemetery area, illustrating the growth of the rubbish-mounds.
- PLATE 272. Section from the SW. Temenos Wall of Nebuchadnezzar through the 'Flood Pit', showing strata earlier than the First Dynasty of Ur.
- PLATE 273. Plan of the Royal Tombs.
- PLATE 274. General plan of the cemetery area containing the Royal Graves.

E - GISH - SHIR - GAL
THE TEMENOS OF UR

THIRD DYNASTY PERIOD . C. 2300 . B.C.
SHOWING THE RELATION OF THE ROYAL TOMBS TO THE
BUILDINGS OF THE HISTORIC PERIODS

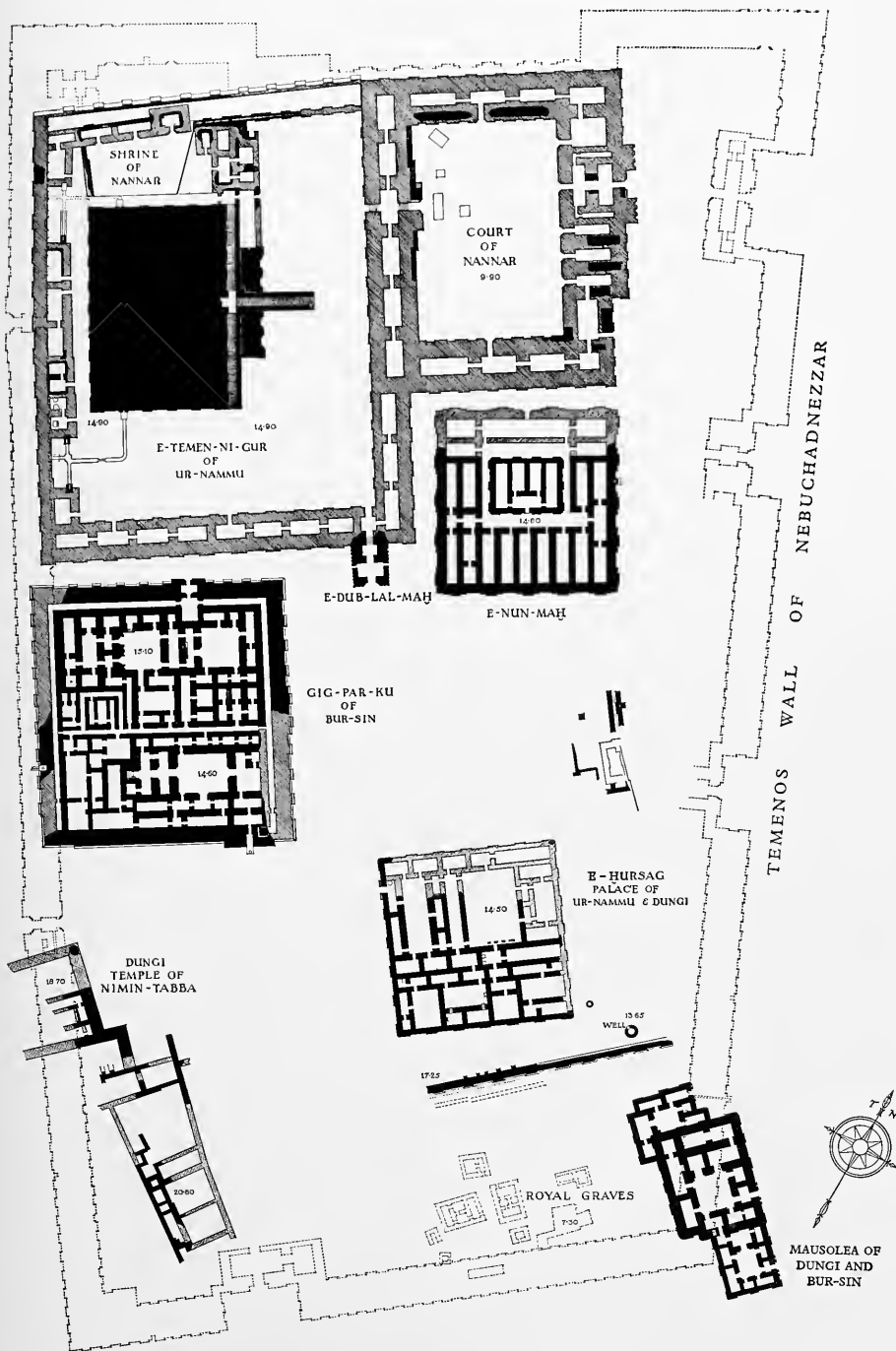

F. G. NEWTON.
A. S. WHITBURN, A.R.I.B.A.
C. L. WOOLLEY, HON. A.R.I.B.A.
J. C. ROSE, A.R.I.B.A.
MENS ET DELT. . . 1922-1932.

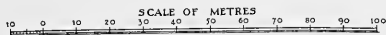



THE CEMETERY, 1931-2

GENERAL VIEW LOOKING NE., WITH WORK IN PROGRESS IN PG 1847;
 IN THE BACKGROUND, BUR-SIN'S NW. ANNEXE OF THE DUNGI TOMB BUILDING

- A = PG/777
- B = PG/580
- C = PG/779
- D = PG/755
- E = PG/789
- F = PG/1237

v. p. 4



a. GENERAL VIEW: EARLY STAGES OF THE EXCAVATION



b. VIEW SHOWING A, THE ROYAL TOMB PG/779, B, THE SITE OF THE GRAVE OF MES-KALAM-DUG, PG/755,
C, THE ROYAL TOMB PG/777



b. THE ROYAL TOMB, PG/779

A = the sloped approach to the tomb door

B = the royal tomb, PG/777

cf. p. 34



a. PART OF THE CEMETERY

A = the royal tomb, PG/777

B = the grave of Mes-Kalam-dug, PG/755

C = the royal tomb, PG/779

cf. p. 4



a. THE EXCAVATION OF THE CEMETERY: ONE OF THE EARTH-CUT STAIRWAYS LEADING DOWN FROM THE SURFACE



b. WORK IN THE UPPER LEVELS AT THE NE. END OF THE CEMETERY AREA

Above, the footings of the Temenos Wall of Nebuchadnezzar



a. THE SW. END OF THE EXCAVATIONS, DECEMBER 1928, SHOWING GRAVES AT DIFFERENT LEVELS



b. GENERAL VIEW OF THE CEMETERY EXCAVATIONS LOOKING SE.

A = grave of Mes-kalam-dug, PG/755
 B = the royal tomb, PG/779

C = the royal tomb, PG/1054
 D = the 'Great Death-pit', PG/1237

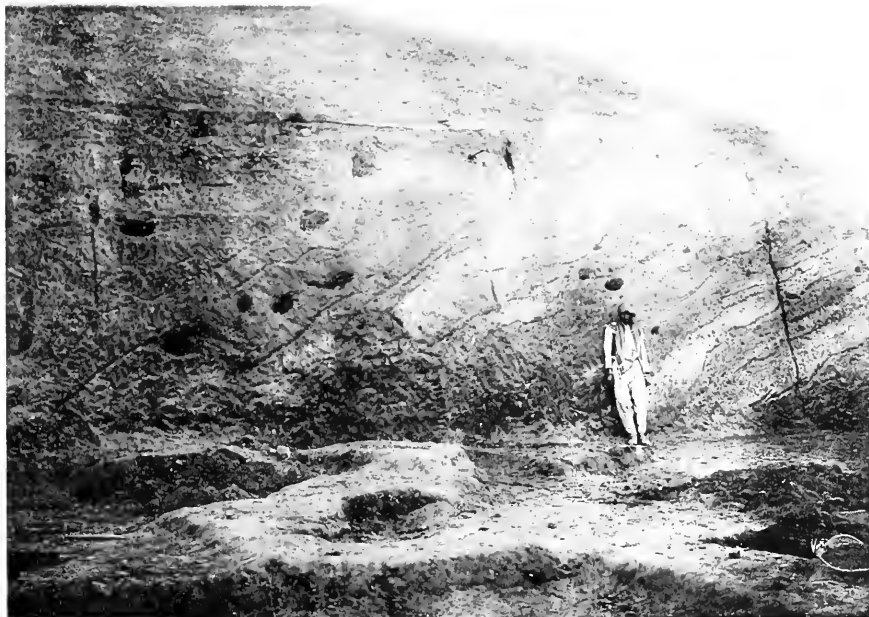

a. THE EARTH FACE OF THE SOUTH CORNER OF THE EXCAVATED AREA, SHOWING THE STRATIFICATION OF THE RUBBISH MOUNDS
v. p. 220



b. PG/1845. THE SLOPING MASS OF BUILDERS' RUBBISH TIPPED INTO THE PLUNDERED SHAFT AT THE TIME OF THE BUILDING OF BUR-SIN'S TOMB
v. pp. 18, 187



a



b

a. PG/39. ABOVE THE DEDICATION BOWL IS A CURVED BAND OF GREY ASH AND BURNT EARTH; THE POINT OF THE MEASURING-ROD COMES AGAINST THIS STRATUM. *v.* p. 147

b. PG/55. GOLD FILLET, SHEET LEAD, STONE VESSELS, ETC., IN POSITION. *v.* p. 148



a. PG/333. THE CLAY COFFIN, AND OFFERINGS BESIDE IT
v. pp. 138, 151



b. PG/337. GOLD HEAD ORNAMENTS, ETC., IN POSITION
v. p. 43



a



b

PG/337

a. LIME FLOOR AND DRAIN HIGH UP IN THE TOMB-SHAFT

b. THE BOTTOM OF THE SHAFT. A, A, A, CLAY VESSELS; B, B, COPPER VESSELS; C, SILVER BELT

v. p. 44



a



b

a. PG/337. STONE VASES LYING ABOVE THE GRAVE, v. p. 45

b. PG/580. THE GOLD DAGGER, TOILET SET AND CYLINDER SEAL ATTACHED TO THE SILVER BELT, v. p. 51



a. PG/389. THE IMPRESSION ON THE SOIL OF THE WOODEN LID OF THE COFFIN
v. p. 137

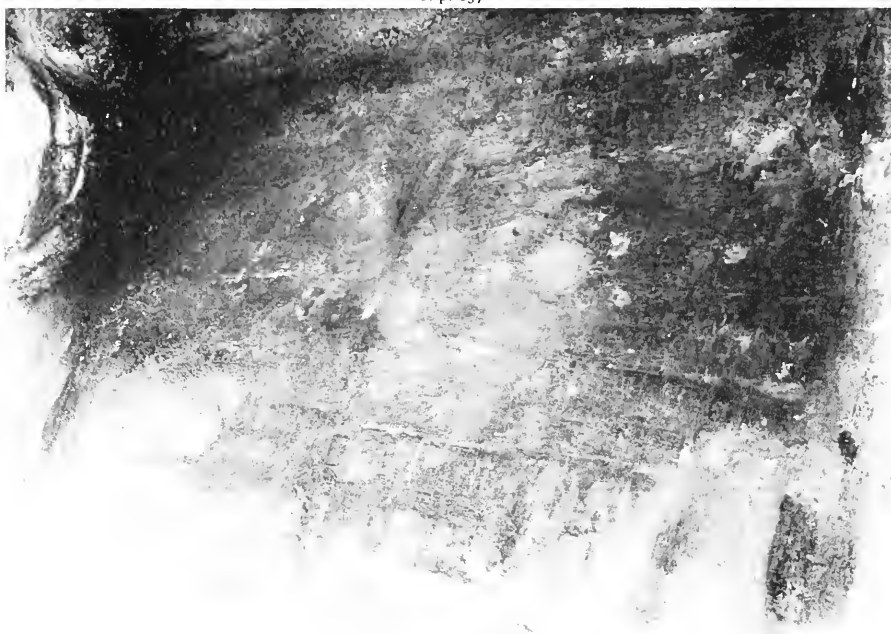

b. COFFIN-LID OF WITHIES ON A LIGHT WOODEN FRAME
v. p. 137



a

PG/503. OBJECTS IN POSITION



b

PG/505. THE MAT-LINED GRAVE WITH THE BODY IN POSITION



a. PG/527. MODEL BOAT AND CLAY POTS. v. p. 145



b. PG/622. BODY IN POSITION
v. p. 139

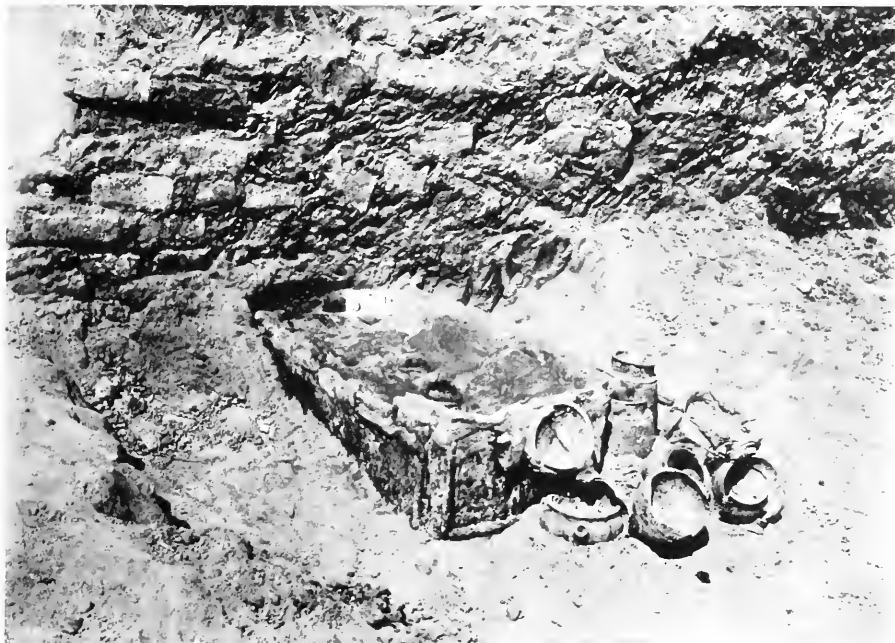

a. PG/659. A SQUARE-ENDED CLAY LARNAX, THE END CUT AWAY BY THE THIRD DYNASTY DRAIN
 v. p. 138



b. ANOTHER VIEW OF THE SAME. BEYOND IS PG/661, AN INHUMATION GRAVE ALSO DISTURBED BY THE
 DRAIN BUILDERS

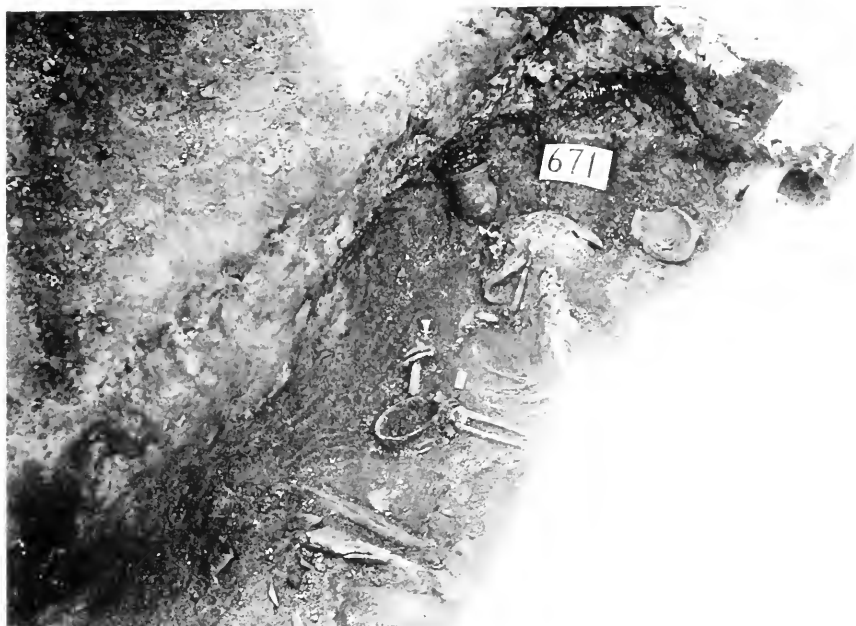

a. PG/671. BODY AND OBJECTS IN POSITION
v. p. 205



b. PG/673. BODY AND OBJECTS IN POSITION



a



b

a. PG/675. BITUMEN BOAT CHARGED WITH A CARGO OF CLAY POTS. THE WHOLE WAS COVERED WITH MATTING OF WHICH TRACES CAN BE SEEN

v. p. 145

b. PG/627. BITUMEN BOAT WITH ITS CARGO OF CLAY POTS

v. p. 204



a



b

a. PG/721. AN UNUSUALLY LARGE BITUMEN BOAT, WITH CLAY AND COPPER POTS, LYING ABOVE THE BODY IN THE GRAVE-SHAFT. THE REED SKELETON ON WHICH THE BOAT WAS MODELLED CAN BE SEEN

v. p. 145

b. PG/760. HEAD-DRESS IN POSITION: SILVER FLOWER 'COMB', THE PETALS INLAID WITH GOLD, SHELL, ETC. (cf. PL. 136), LARGE GOLD EAR-RINGS, GOLD WREATH AND BEADS



a



b

PG/777

- a.* THE SHAFT CLEARED TO ROOF-LEVEL
- b.* THE STONES OF THE FALLEN ROOF EXPOSED

v. p. 53



a. PG/777. THE SW. SIDE OF THE SHAFT SHOWING STRATIFIED RUBBISH, AND THE WALLS OF THE STONE CHAMBER BUILT IN THE SHAFT. v. p. 14



b. PG/777. INTERIOR OF THE CHAMBER SHOWING (X X X) THE HOLES IN THE STONEMWORK LEFT BY THE ROOFING-BEAMS. v. pp. 53, 233

P.G. 779

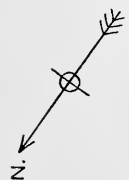

B

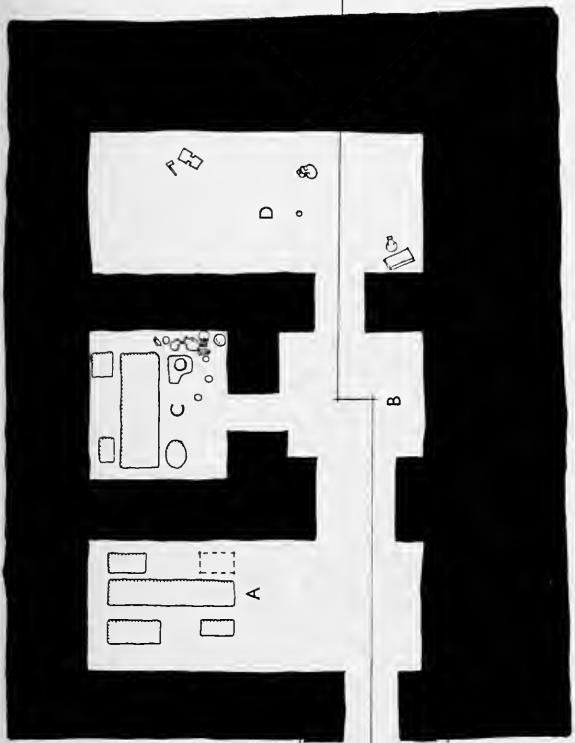

PLAN

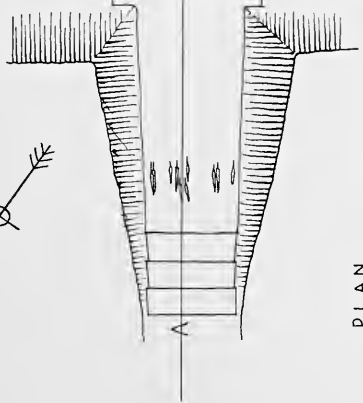

SECTION A-B

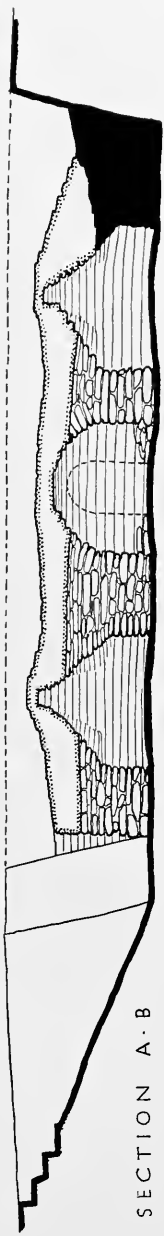

GROUND-PLAN AND SECTION OF PG/779

2. P. 57



a



b

PG/779

a. VIEW OF THE DOORWAY LOOKING UP THE SLOPED DROMOS

b. VIEW FROM THE DOOR WITH THE INTERIOR OF THE TOMB

v. p. 57



a



b

PG/779

a. CHAMBER A, THE NE. END

b. GENERAL VIEW LOOKING DOWN INTO THE TOMB

v. pp. 57, 232



a



b

PG/779

a. NE. END OF CHAMBER A, SHOWING THE SYSTEM OF PENDENTIVES AND THE SEMI-CORBELLING OF THE ROOF

b. NE. END OF CHAMBER C, SHOWING THE CEMENT FLOOR WITH DEPRESSION FOR THE COFFIN AND HOLES PERHAPS FOR THE CANOPY SUPPORTS

v. pp. 59, 232



a



b

PG/779

a. CHAMBER D, NE. END

b. CHAMBER D, SW. END

v. p. 57

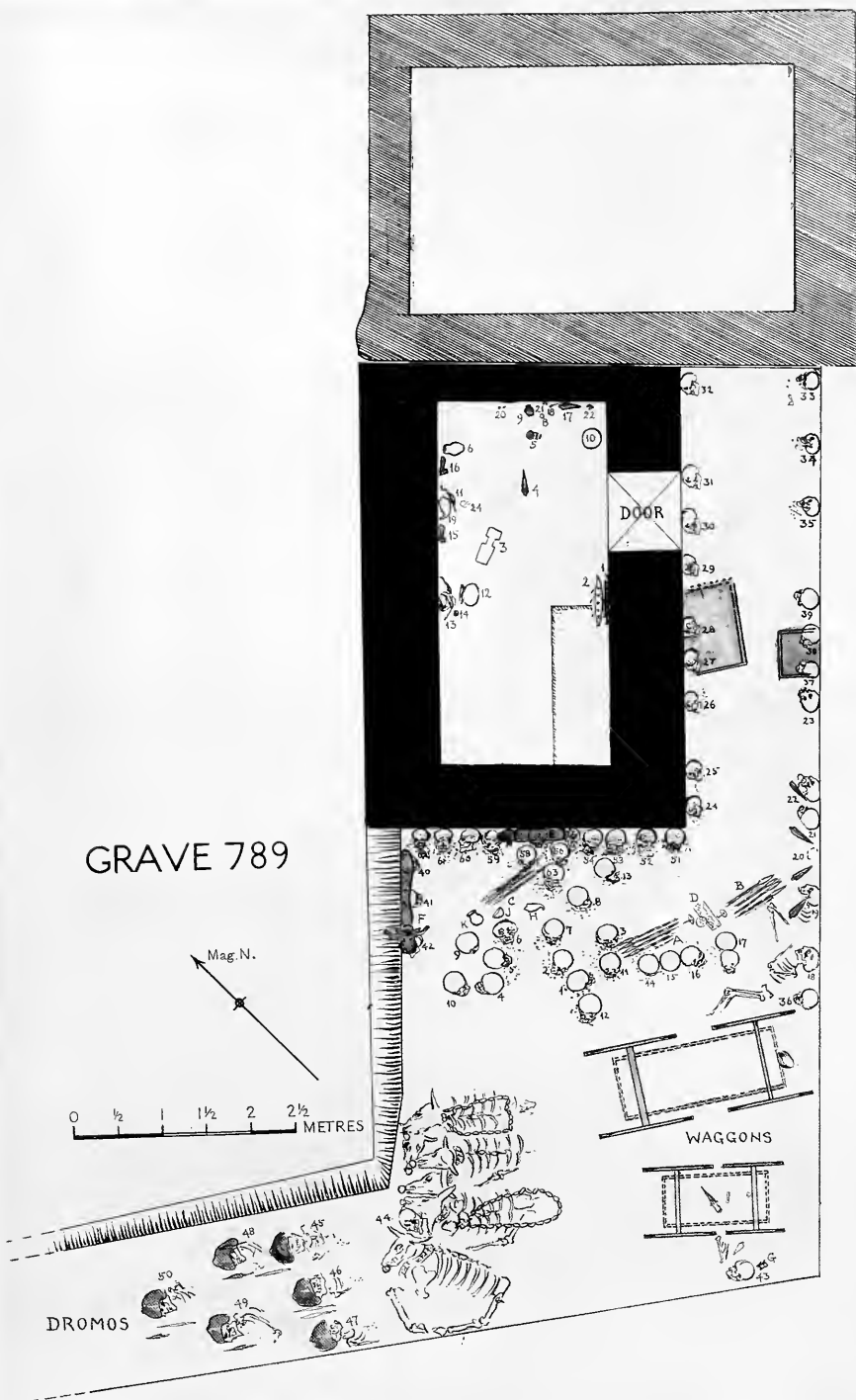

GRAVE 789

0 1/2 1 1 1/2 2 2 1/2 METRES

WAGGONS

DROMOS

GROUND-PLAN OF PG/789, SHOWING THE POSITION OF OBJECTS AND BODIES

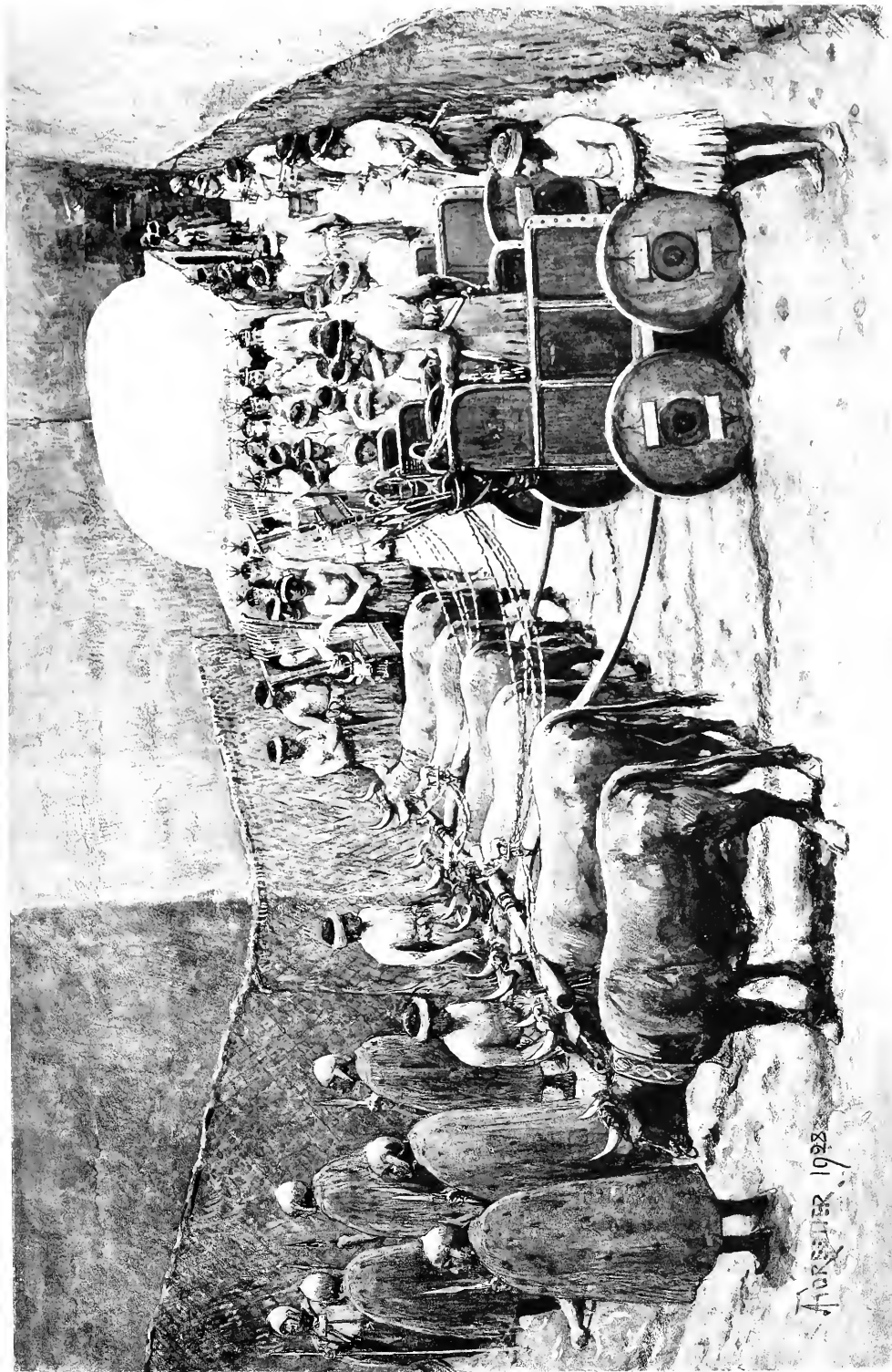

PG/789. A RECONSTRUCTION OF THE SCENE IN THE DEATH-PIT
The persons and objects are drawn in the positions in which their remains were found
Drawing by A. FORESTER: reproduced by permission of the proprietors of the Illustrated London News
v. p. 35



a



b

PG/789

a. THE TOMB-CHAMBER BEFORE EXCAVATION, SHOWING THE FALLEN BRICKWORK AND THE STANDING RING OF THE
VAULT
v. p. 62

b. THE TOMB-CHAMBER AFTER EXCAVATION, SHOWING THE VAULT AND APSIDAL END IN BURNT BRICK RESTING ON
WALLS OF LIMESTONE RUBBLE
v. pp. 63, 233



a

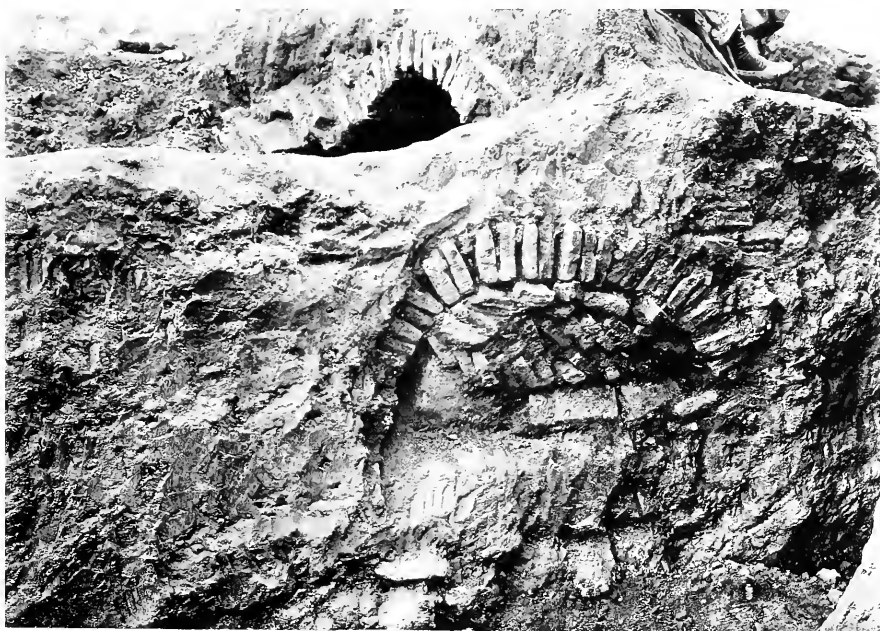

b

PG/789

a. THE STANDING RINGS OF THE BRICK VAULT, AND THE NE. WALL OF LIMESTONE RUBBLE

b. THE SE. WALL OF THE TOMB-CHAMBER SEEN FROM THE OUTSIDE, SHOWING THE BRICK ARCH OF THE DOOR, THE DOOR-BLOCKING OF BRICK AND STONE, THE WALL OF LIMESTONE RUBBLE PLASTERED WITH CLAY AND, ABOVE, THE REMAINS OF THE BRICK VAULT

v. pp. 233-5



a



b

PG/789. THE WAGONS

a. THE TWO NEAR WHEELS OF THE FIRST WAGON, SEEN FROM THE INSIDE

b. THE SECOND WAGON SEEN FROM THE OUTSIDE, SHOWING BOTH SETS OF WHEELS AND THE REMAINS OF THE AXLES. A SILVER BOWL LIES BY THE BACK AXLE

v. p. 64



a



b

PG/789. THE WAGONS

a. THE REMAINS OF THE FIRST WAGON WITH ITS REINS AND REIN-RING

b. THE REINS AND REIN-RING OF THE FIRST WAGON *in situ*

v. p. 64



a

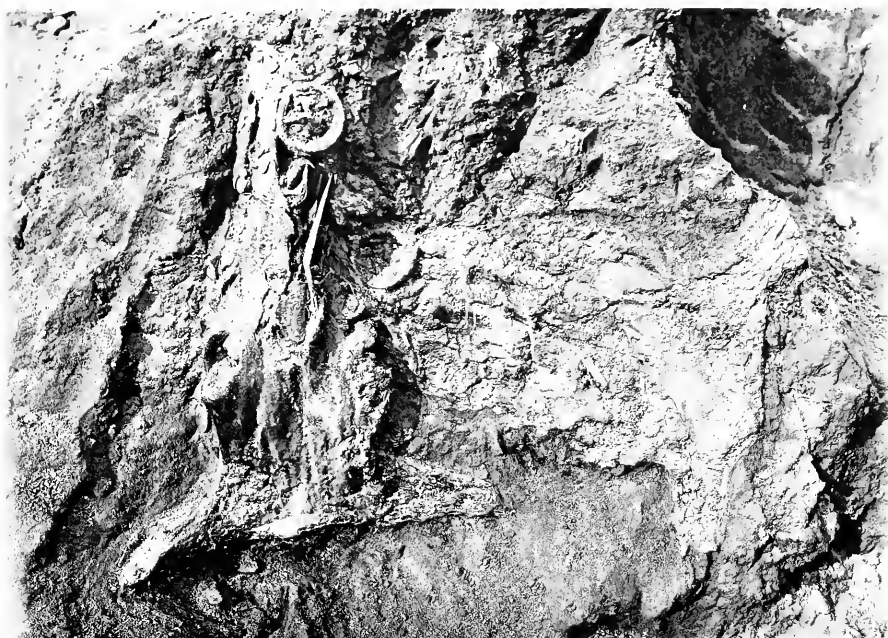

b

PG/789

a. THE SKELETON OF ONE OF THE OXEN ATTACHED TO THE WAGONS, SHOWING THE SILVER RING IN THE NOSE

b. SKULLS OF TWO OF THE OXEN, EACH WITH A SILVER RING IN THE NOSE

v. p. 64



GRAVE 800.

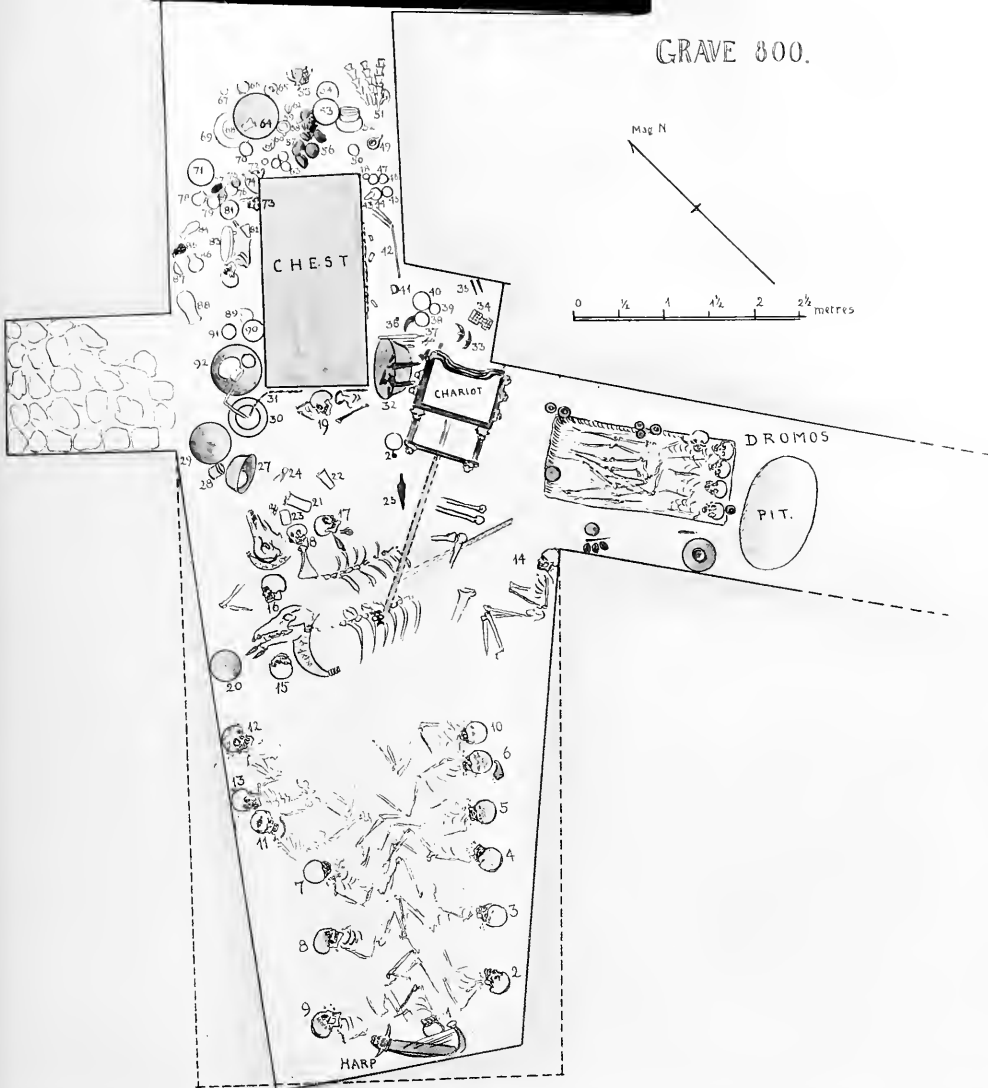

GROUND-PLAN OF QUEEN SHUB-AD'S DEATH-PIT AND TOMB-CHAMBER PG/800



No. 3

No. 4



No. 5

No. 6

PG/800. HEAD-DRESSES OF QUEEN SHUB-AD'S WOMEN
v. pp. 73 et seq.



a



b

PG/800. U. 10412. QUEEN SHUB-AD'S HARP

- a. The harp in position, showing the gold head (A) attached to the mosaic border which is covered with wax and muslin for removal: the upright is still buried in the high earth to the left. By the harp, the head-ornaments of the harpist.
- b. The harp upright with its gold band and keys in position exposed by the removal of the soil: the mosaic border of the square end of the sounding-box, and remains of silver plate below it.

v. Pls. 104, 108-10, and pp. 74 *et seq.*



a



b

PG/800. TOMB OF QUEEN SHUB-AD

a. THE COPPER COLLAR OF ONE OF THE ASSES

b. THE SKELETONS OF THE TWO ASSES ATTACHED TO THE CHARIOT. IN THE CENTRE, THE REIN-RING, U. 10439; AT (A) A COPPER COLLAR; AT (B) THE SKULL OF ONE OF THE GROOMS

v. Pl. 166 and p. 78



a



b

PG/800. THE WOODEN 'WARDROBE' CHEST
v. p. 80



a



b

PG/800. THE WOODEN 'WARDROBE' CHEST

a. THE NORTH CORNER. A-A, THE CHEST; B, B, SILVER LIONS' HEADS; C, SILVER VESSELS; D, GOLD VESSELS

b. THE NE. END. A-A, THE CHEST; B, SILVER VESSELS; C, COPPER VESSELS; D, GOLD VESSELS; E, STONE VESSELS; F, SILVER LION'S HEAD

v. p. 80



a



b

PG/800. THE TOMB-CHAMBER OF QUEEN SHUB-AD

a. STONE, COPPER, AND SILVER VESSELS BELOW THE STANDING RING OF THE ROOF VAULT

b. THE SE. END OF THE CHAMBER, SHOWING OBJECTS EVIDENTLY FALLEN FROM SHELVES ALONG THE WALL



a



b

PG/800

- a.* THE INTERIOR OF THE TOMB-CHAMBER, NE. SIDE, SHOWING STONE AND METAL VESSELS IN POSITION
b. THE HEAD-DRESS OF QUEEN SHUB-AD IN POSITION. THE PINS AND AMULETS ARE SEEN BY THE RIGHT SHOULDER. THE BULK OF THE BEADS COVERING THE UPPER PART OF THE BODY HAD BEEN REMOVED BEFORE THE PHOTOGRAPH WAS TAKEN



a. PG/823. COPPER AND STONE VESSELS: BEADS WORN AT THE SHOULDER, DAGGER, WHETSTONE, AND GOLD TWEEZERS



b. PG/851. BODY IN POSITION



a



b

a. PG/861. THE WOODEN COFFIN AND ITS CONTENTS. v. p. 137

b. PG/1043. THE MASS OF CLAY VESSELS *in situ*



a

THE OUTLINES OF THE TWO COMPARTMENTS OR CHAMBERS HIGH UP IN THE SHAFT.
(X) IS THE LAYER OF REEDS LAID OVER THE POTTERY



b

SECOND STAGE OF EXCAVATION. PART OF THE REED LAYER REMOVED TO SHOW THE
POTTERY BELOW IT

PG/1050

v. p. 91



a



b

PG/1050

a. THE SECOND STAGE OF EXCAVATION. ANOTHER VIEW SHOWING THE REED LAYER IN PROCESS OF REMOVAL

b. ALL THE REED LAYER REMOVED AND THE POTTERY AND HUMAN BONES EXPOSED

v. p. 91



a



b

PG/1050

a. THE PLUNDERED TOMB-CHAMBER, UNDER THE DISTORTED COPPER POT (X) WAS FOUND THE SEAL OF A-KALAM-DUG
v. p. 94

b. VIEW LOOKING STRAIGHT DOWN INTO PART OF THE 'DEATH-PIT' AND SHOWING THE DECAYED CONDITION OF
THE BODIES
v. p. 91



a



b

PG/1054. THE TOP LEVEL IN THE SHAFT

a. WHITE CALCITE VASE AND TRACES OF WALLING. IN THE FOREGROUND THE INTRUSIVE BURIAL PG/1053

b. THE WHITE CALCITE VASE, OUTLINES OF WOODEN BOX, AND CLAY VESSELS

v. p. 97

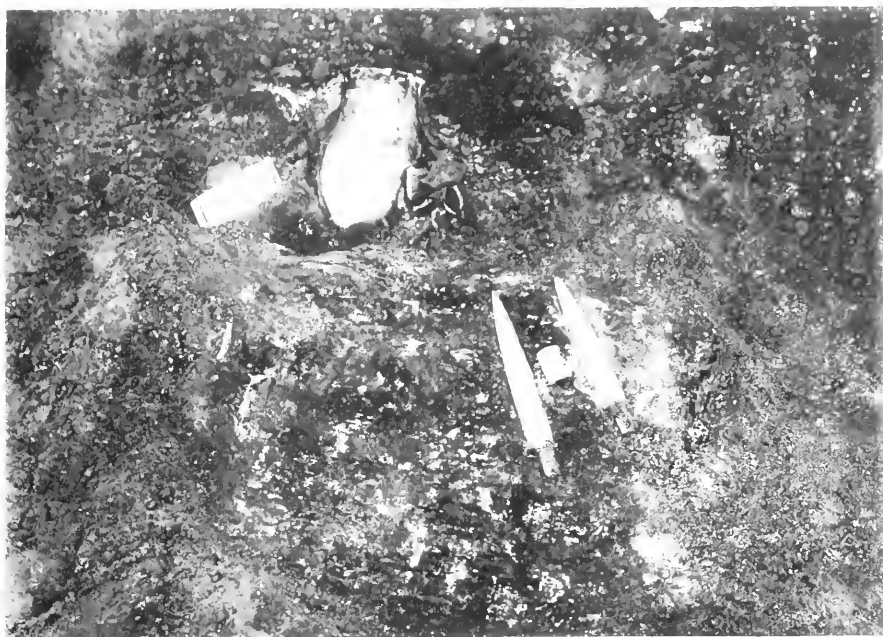

a



b

PG/1054 THE UPPER LEVELS IN THE SHAFT

a. THE WOODEN BOX OPENED TO SHOW TWO GOLD DAGGERS AND THE CYLINDER SEAL OF KING MES-KALAM-DUG

b. THE CROSS WALL OF THE TOP STRUCTURE WITH THE TWO COMPARTMENTS CONTAINING CLAY, COPPER, AND STONE VESSELS



a



b

PG/1054

a. UPPER LEVEL, THE BURIAL (A) IN THE SOUTH CORNER OF THE SHAFT

b. SECOND STAGE OF EXCAVATIONS: THE LAYER OF POTTERY AND BONES EXTENDING OVER THE SHAFT

v. p. 99



a



b

PG/1054. THE SHAFT

a. THE BURIAL B IN THE WEST CORNER

b. THE BURIAL A

v. p. 99

*a**b*

PG/1054. THE SHAFT

- a.* THE WOODEN COFFIN OF BURIAL C, THE RIGHT-HAND END BROKEN AWAY TO EXPOSE THE INTERIOR
b. SECTION IN THE SHAFT SHOWING CLAY VESSELS IN TIERS ONE ABOVE ANOTHER. THE LABEL IS ON THE LEVEL OF THE WOODEN COFFIN SHOWN IN THE UPPER PHOTOGRAPH



a

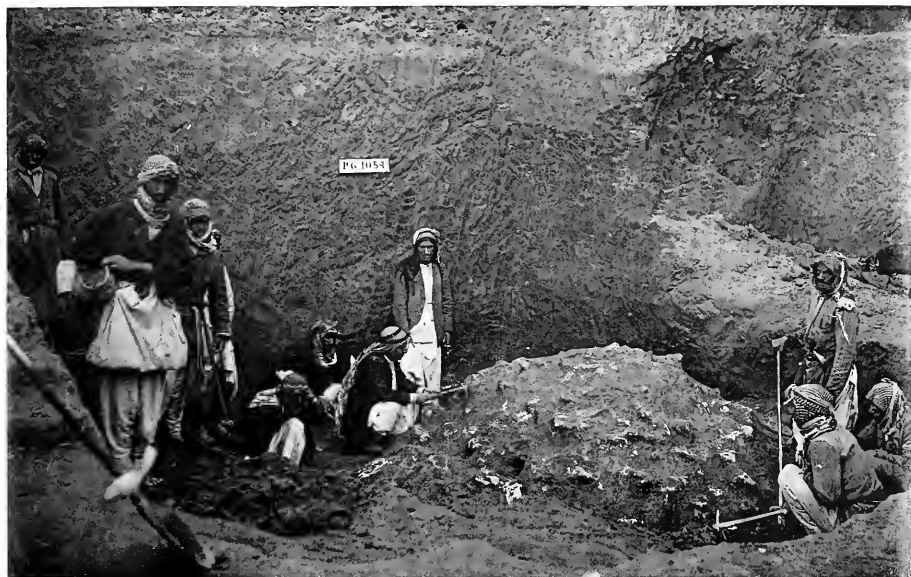

b

PG/1054

a. THE BURIAL C, SHOWING THE INTERIOR OF THE COFFIN
v. p. 99

b. CLEARING THE TOP OF THE STONE DOME
v. p. 103



a



b

PG/1054

a. THE TOP OF THE STONE DOME, SHOWING THE HOLES LEFT BY THE CENTERING BEAMS
v. p. 234

b. DIGGING DOWN TO THE TOMB-CHAMBER ENTRANCE
v. p. 103

*a**b*

PG/1054. THE CHAMBER

a. THE FRONT OF THE DOMED CHAMBER FROM THE COURTYARD, SHOWING THE OPENED DOOR*b.* THE FLOOR OF THE CHAMBER, SHOWING THE REMAINS OF WOODWORK OVERLYING THE BODIES (PHOTOGRAPH TAKEN THROUGH ONE OF THE BEAM-HOLES IN THE ROOF). AT (X) A COPPER POT, GOLD EAR-RING, AND GOLD RIBBON

v. p. 103



a



b

PG/1054. THE INTERIOR OF THE DOMED CHAMBER

a. THE SIDE WALL AND THE SPRINGERS OF THE DOME

b. VIEW OF THE ROOF LOOKING UP TO THE CAP-STONE



a



b

a. PG/1068. 'THE GRAVE OF THE LITTLE PRINCESS.' STONE VASES IN POSITION; IN ONE OF THEM THE GOLD CUP U. 11551; IN THE CENTRE WREATHS OF GOLD LEAVES AND GOLD RINGS

v. p. 162

b. PG/1069. THE GRAVE CLEARED, WITH OBJECTS *in situ*

v. p. 164



a



b

PG/1100

a. THE GRAVE AS FIRST DISCOVERED. THE HOLES IN THE SOIL ARE DUE TO THE DECAY OF THE UPRIGHT STAYS OF THE COFFIN-SIDES: WHERE THE ROOF HAS FALLEN THE IMPRESSION OF THESE IN THE SOIL CAN BE SEEN. THE ROOF IS OF MUD BRICKS LAID OVER THE WOODEN LID OF THE COFFIN

b. THE GRAVE CLEARED: ALONG THE SIDES THE IMPRESSION OF THE WOODEN PLANKS AND UPRIGHT STAYS OF THE COFFIN



a. PG/1130. THE JEWELLERY IN POSITION: GOLD RIBBON FILLETS, A WREATH WITH GOLD PENDANT RINGS, REMAINS OF DIADEM WITH GOLD ANIMAL AND FRUIT PENDANTS, PIN, CYLINDERS, BEADS, ETC.
v. p. 165



b. PG/1141. REMAINS OF A RECTANGULAR CLAY COFFIN WITH RIBBED DECORATION BASED ON THE UPRIGHT STAYS OF WOODEN AND WICKERWORK COFFINS
v. p. 138



a



b

a. PG/1219. A RECTANGULAR RIBBED CLAY COFFIN
 (THE STONE VESSELS IN FRONT ARE AT A LOWER LEVEL AND BELONG TO PG/1220)
 v. p. 38

b. PG/1234. GOLD HEAD-DRESS, CLAY POTS, ETC., *in situ*
 v. p. 171



a



b

PG/1232

a. THE IMPRESSIONS OF THE CHARIOT WHEELS, AND COPPER VESSELS

b. WEAPONS AND METAL VESSELS RESTING ON MATTING ON THE LOWER FLOOR-LEVEL IN THE CORNER OF THE PIT

v. p. 108



a



b

PG/1236

a. THE DOORWAY, THE STONWORK OF THE ARCHED DOOR FACED WITH CEMENT, THE BLOCKING OF THE DOORWAY MUD-PLASTERED

b. THE TWO CENTRAL DOMED CHAMBERS AND THE NE. VAULTED CHAMBER, SEEN FROM ABOVE



a



b

PG/1236

a. THE TWO CENTRAL DOMED CHAMBERS AND THE SW. VAULTED CHAMBER, SEEN FROM ABOVE

b. THE NE. CHAMBER AS DISCOVERED: THE ROBBERS' HOLE AT THE SE. END AND THE REST OF THE ROOF INTACT



b

PG/1236. THE NW. END OF THE NE. CHAMBER (CHAMBER A),
SHOWING THE CEMENT FLOOR AND CLAY POTS IN POSITION

v. p. 111

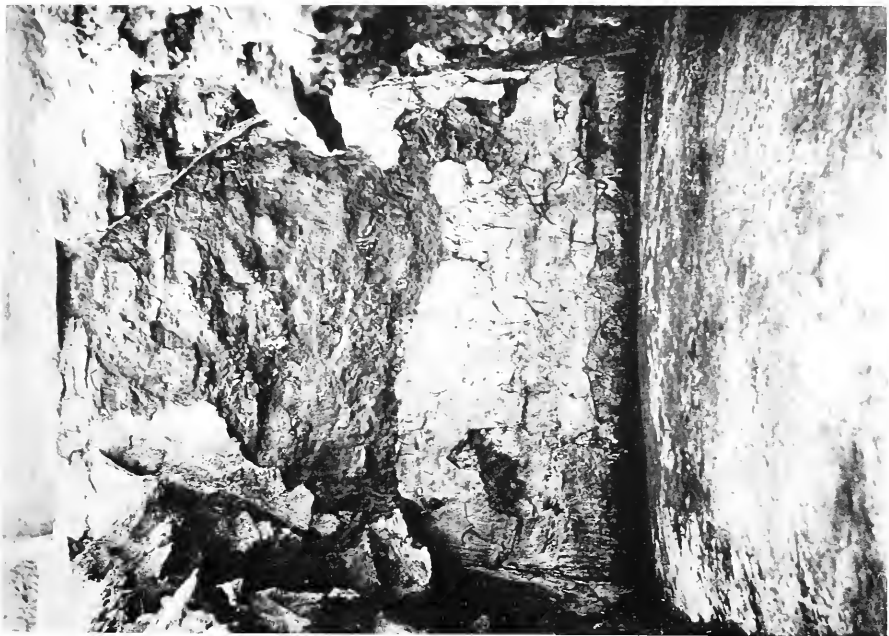

a

PG/1236. THE SE. END OF THE NE. CHAMBER (CHAMBER A),
SHOWING THE WHITE CEMENT FACE ON WALLS AND FLOOR



a



b

PG/1236

- a.* THE DOORWAY FROM THE DOMED CHAMBER B TO THE NE. CHAMBER A
b. CHAMBERS B, C, AND D, SHOWING AT ↓ THE VERTICAL POST-HOLE FOR THE FRAME OF THE COMMUNICATING DOOR
v. pp. 111, 235, &c.



a



b

PG/1236

a. THE DOORWAY FROM CHAMBER B TO CHAMBER C: THE FALLEN STONEWORK AND, AT X, THE VERTICAL HOLLOW FOR THE WOODEN DOOR-FRAME

v. p. 235

b. CHAMBER C, THE REMAINS OF THE STONE DOME

v. p. 234



a. REMAINS OF CIRCULAR PAVEMENTS OF PLANO-CONVEX BRICK

v. p. 37



b. THE 'OFFERING-TABLE' OF PLANO-CONVEX BRICK AND BITUMEN ABOVE PG/1237

v. p. 114



a



b

PG/1237

a. GENERAL VIEW, SHOWING MEN IN THE 'DEATH-PIT' CLEARING DOWN TO THE GOLD OBJECTS

b. EXCAVATING THE LYRES

v. p. 113

DEATH-PIT PG. 1237

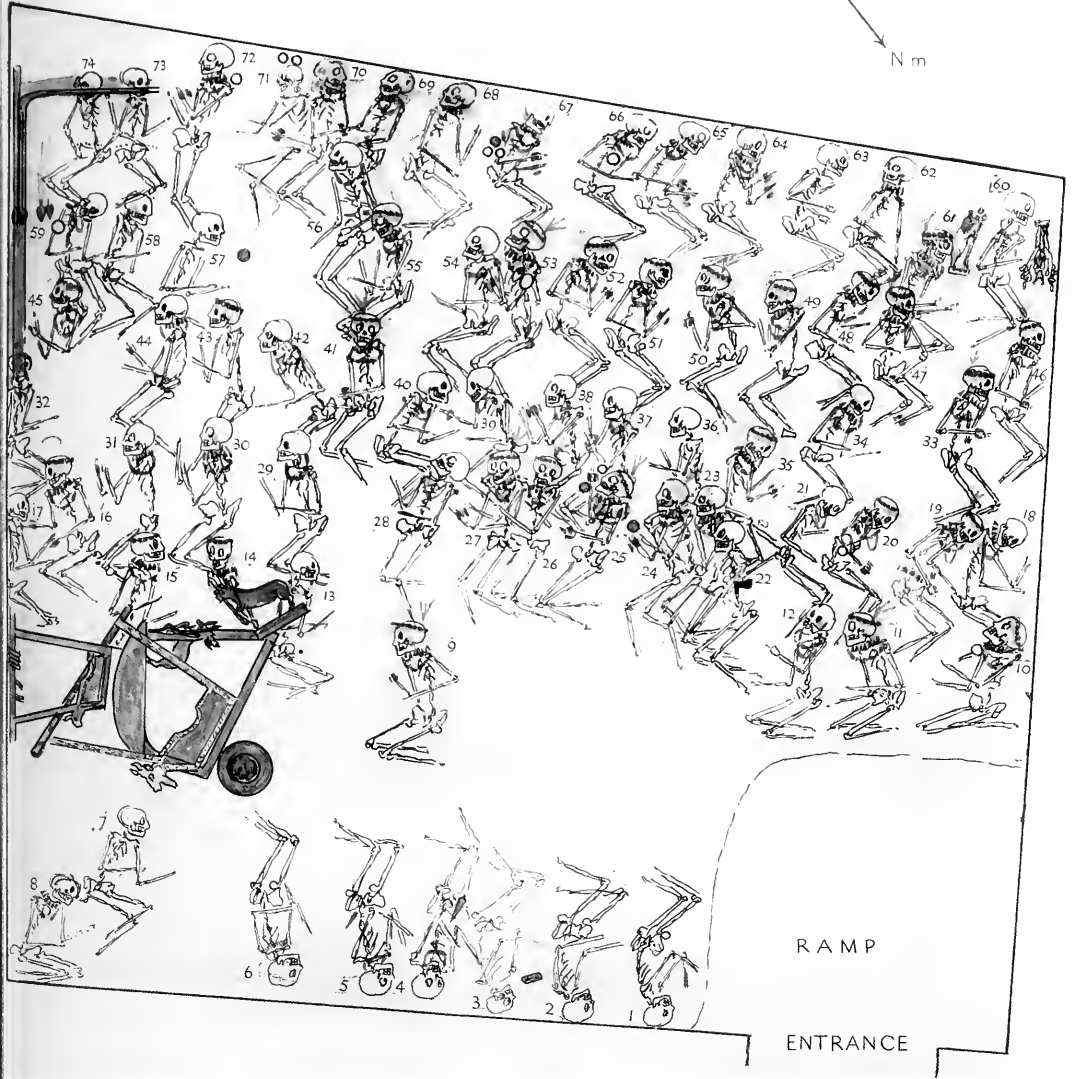
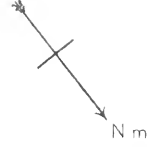

THE BODIES IN POSITION IN THE GREAT DEATH-PIT PG/1237

v. p. 113



a



b

PG/1237

EXAMPLES OF WOMEN'S HEAD-DRESSES, SHOWING THE RIBBONS, WREATHS, ETC., IN POSITION IN THE SOIL
v. p. 116



a



b

PG/1237. DETAILED VIEWS OF THE 'CANOPY', U. 12358

In (a) can be seen, beyond the human bones, the two silver-plated bars A, B, the central bar C with gold bands, silver plating, shell rings and studs and mosaic incrustation, and (D) the curved silver part with mosaic edging. In (b) more of the curved part is visible: also, at x, two of the gilt staff-heads.



a



b

PG/1237

a. THE RUINED COPPER FIGURES OF TWO STAGS, U. 12356

v. p. 123

b. THE HEAD-DRESS (U. 12380) OF BODY NO. 61 IN POSITION

v. Pl. 144

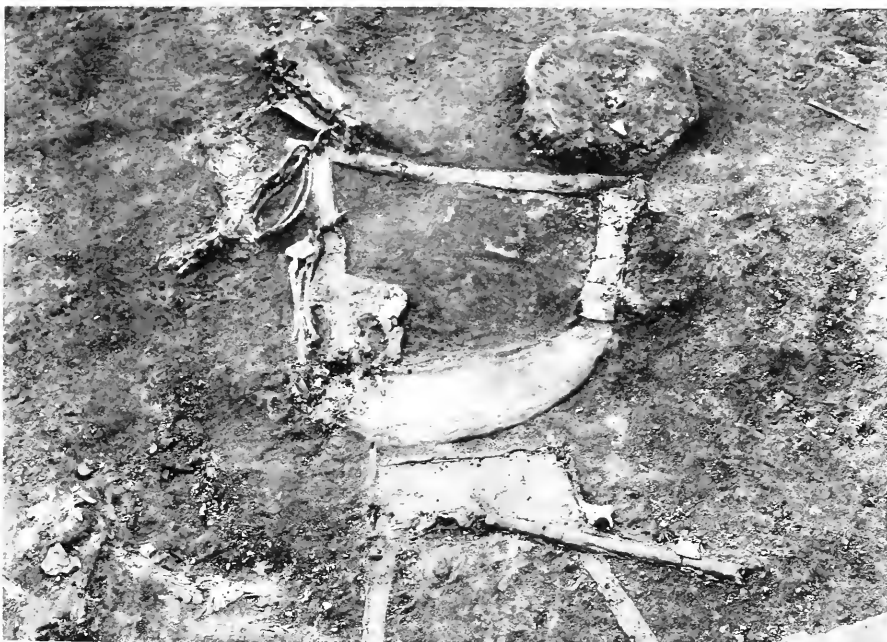
*a**b*

PG/1237. TWO VIEWS OF LYRES IN POSITION

a. IN THE FOREGROUND THE RUINED FIGURES OF TWO STAGS, U. 12356

b. THE SILVER LYRE, U. 12355, AND THE RUINED FIGURES, U. 12356

v. p. 122 and Chap. XIII



a

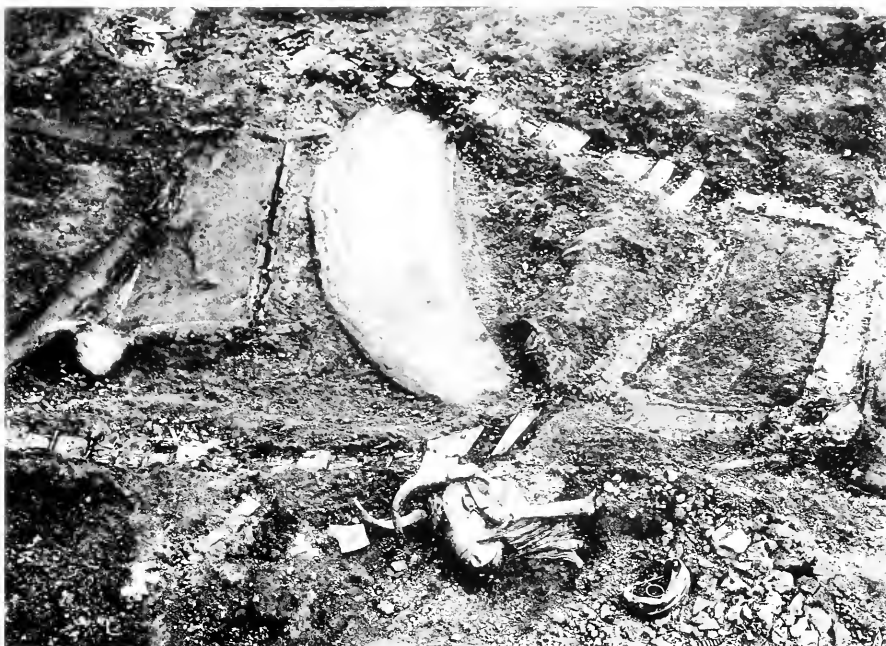

b

PG/1237. TWO VIEWS OF THE LYRES, AS EXCAVATED, LYING IN POSITION
v. p. 122 and Chapter XII



U. 12357 B. THE STATUE (UPPER PART) AS FOUND, GIVING THE SPACING OF THE TREE-BRANCHES; THE LOWER PART OF THE BODY WAS BROKEN OFF.
v. p. 121 and Pl. 89

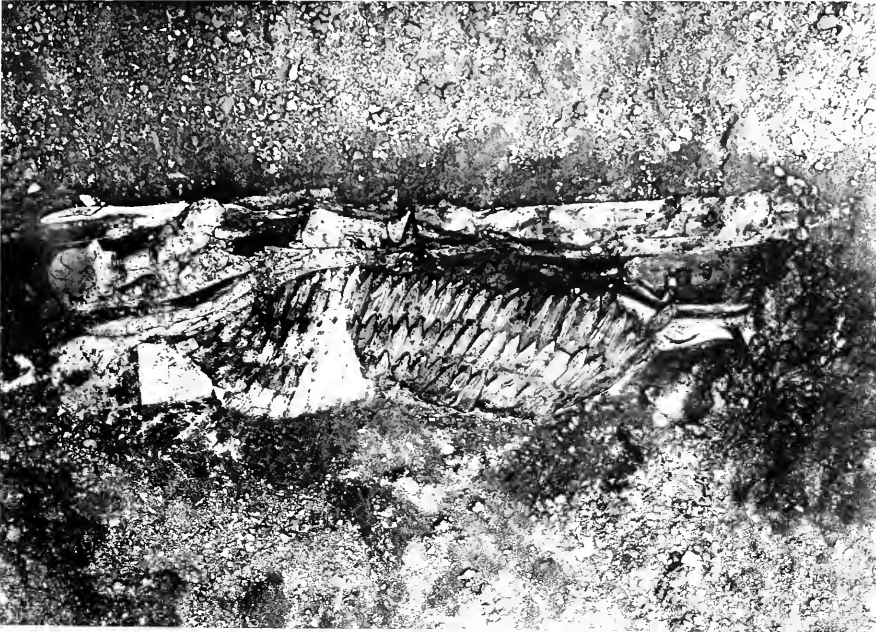

PG/1237. U. 12357 A. THE STATUE AS FOUND, CRUSHED FLAT BUT PRESERVING THE SILHOUETTE OF THE FIGURE AS SEEN FROM THE SIDE
v. p. 121 and Pl. 87



b

PG/1422. THE INTERIOR OF THE WOODEN COFFIN SHOWS GOLD BRACELETS, GOLD FILLETS ON THE SKULL, COPPER DAGGER, VASES, ETC.

z. p. 184



a

PG/1422. THE COLLAPSED WOODEN LID OF THE COFFIN

z. p. 184



a. PG/1548. THE BONES AND OBJECTS IN POSITION



b. PG/1578. LARNAX GRAVE CONTAINING A PARTIALLY CREMATED BODY, INTRUSIVE IN PG/1551



a



b

PG/1618

a. LOOSE BLOCKS OF LIMESTONE PULLED UP FROM THE TOMB-CHAMBER OF PG/1648

b. THE PRINCIPAL BODY IN POSITION, WITH GOLD DAGGER, FILLET, ETC.

v. p. 128



a. PG/1631. THE INTERIOR OF THE PLUNDERED STONE CHAMBER
r. p. 130



b. PG/1648. THE INTERIOR OF THE STONE CHAMBER
v. p. 133

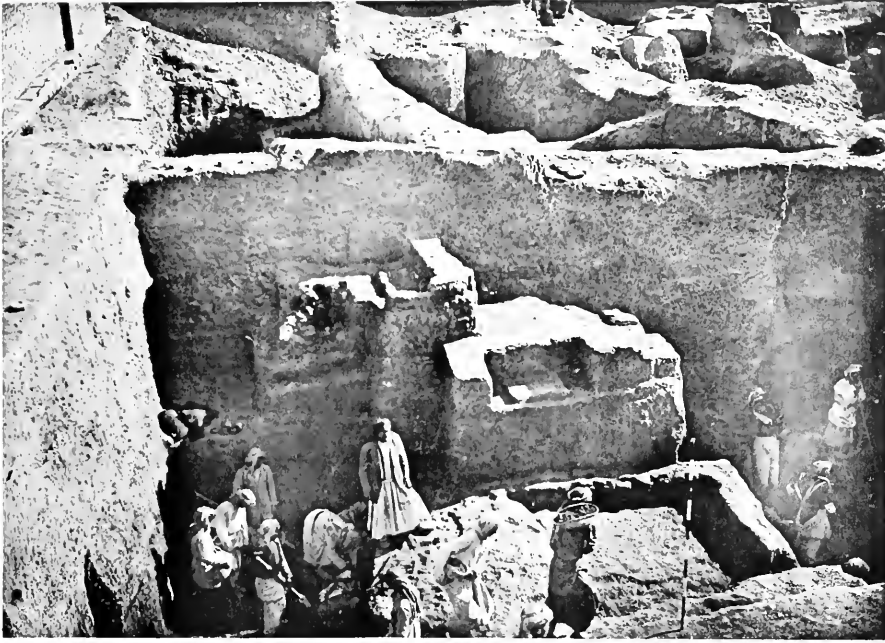

a

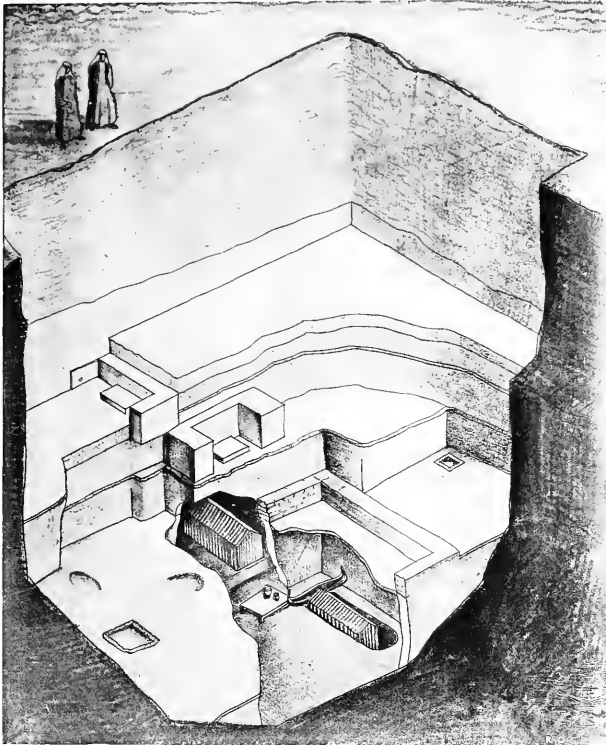

b

PG/1847

- a.* THE SHAFT IN COURSE OF EXCAVATION
- b.* DIAGRAMMATIC SECTION OF THE SHAFT



a



b

PG/1847

a. THE NICHEs AND ALTARS ON THE UPPER AND LOWER FLOOR-LEVELS

b. A, THE TOP NICHE AND ALTAR; B, THE SECOND NICHE AND ALTAR; C, THE WALLED ENCLOSURE;
DD, FIREPLACES

v. pp. 193-4



a



b

PG/1847

a. LOWEST LEVEL: ABOVE, THE WALL OF THE ENCLOSURE, RESTING ON MUD-BRICK PACKING; THE BITUMEN BOAT AND REED TABLE IN POSITION AND, IN FRONT, THE COFFIN-PIT

b. THE TABLE-TOP: PART OF THE SMOOTH CLAY PLASTER HAS BEEN REMOVED TO EXPOSE THE REEDS



a



b

PG/1847. TWO VIEWS OF THE COFFIN (BURIAL S)
v. p. 195



a. PG/1847. DETAIL OF THE COFFIN (S), SHOWING THE STRING BINDING

v. p. 137

b. PG/1851. BITUMEN BOAT, SHOWING THE SKELETON OF WITHIES ON WHICH THE BITUMEN WAS PLASTERED

v. p. 145

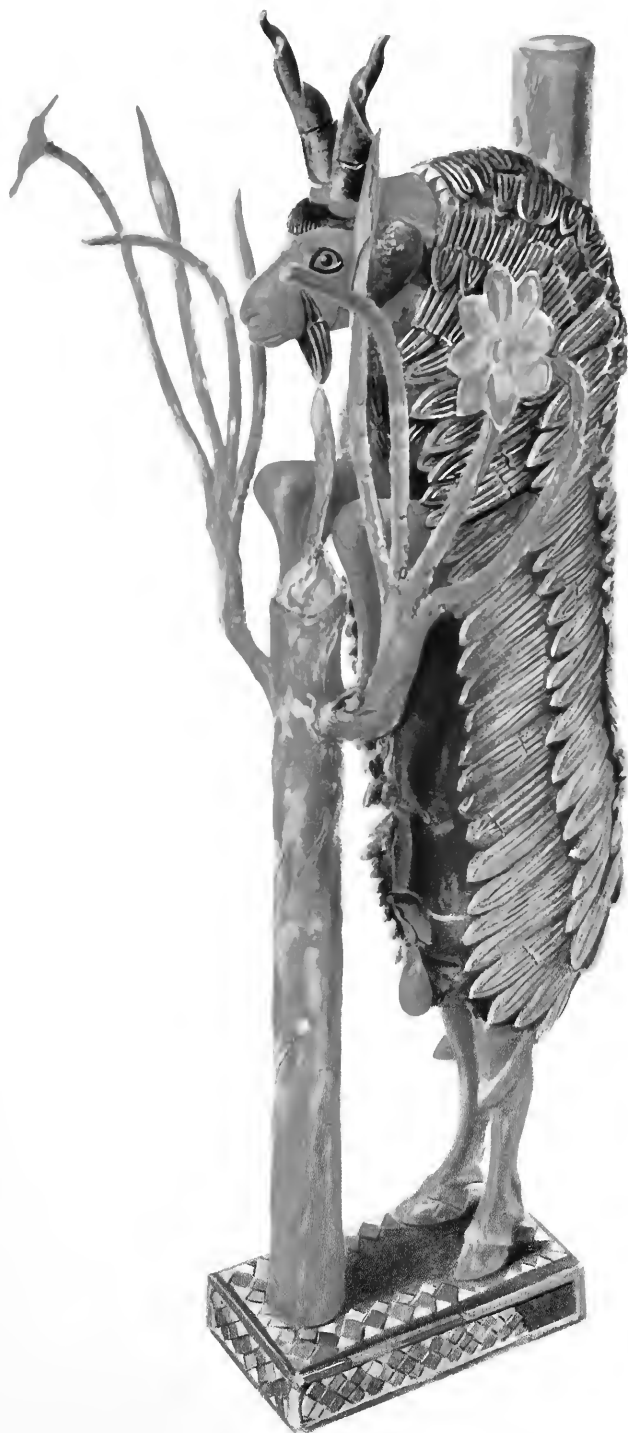

U. 12357 A. "THE RAM CAUGHT IN A THICKET"

One of the two goat statuettes from the Great Death-pit.

Scale *c.* $\frac{1}{3}$ (ht. 0.50 m.)

v. pp. 121, 264

M. Louise Baker pinx.

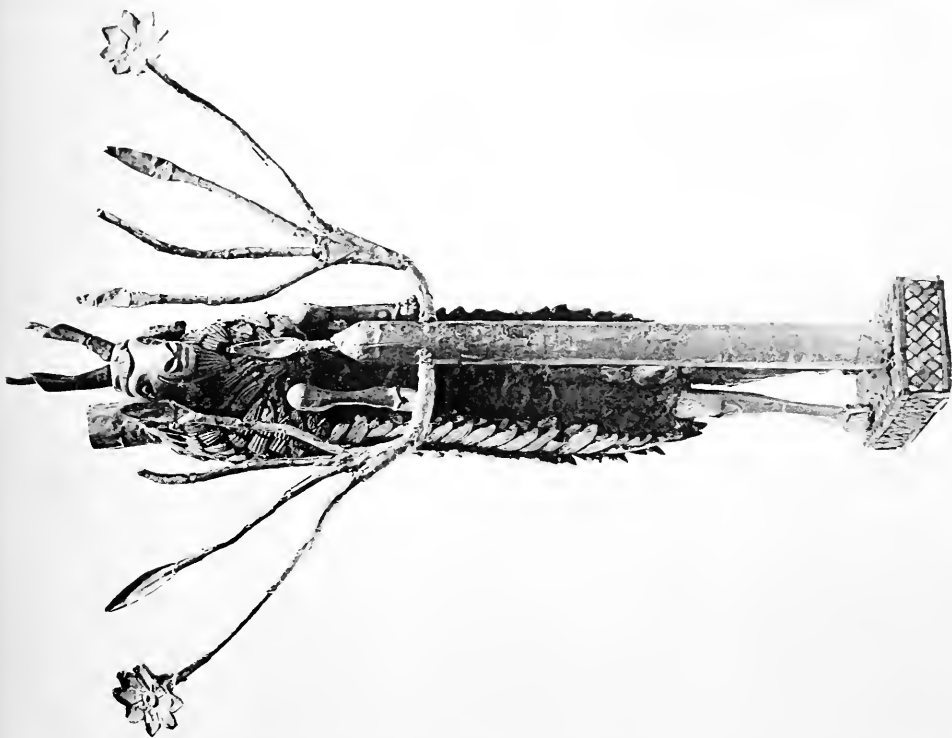
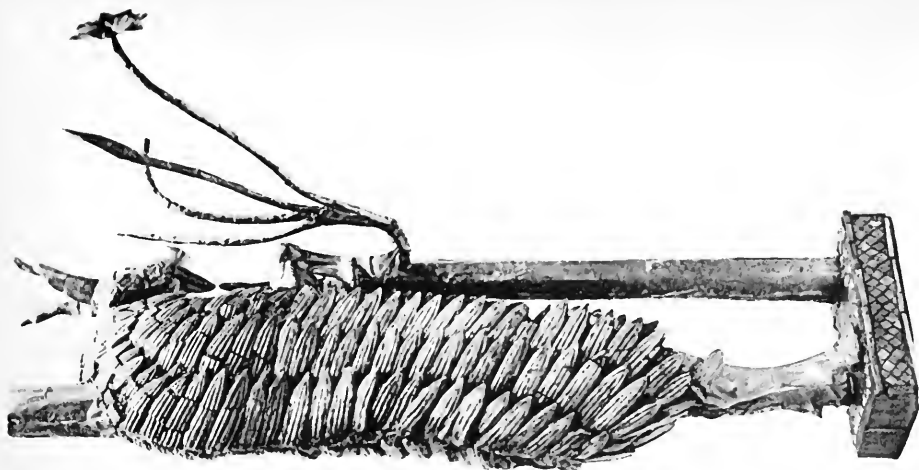

U. 12357 A. FRONT AND BACK VIEWS
Scale $c. \frac{1}{3}$ v. p. 264



U. 12357 B. THE OTHER RAM STATUETTE FROM PG/1237
v. p. 264



a. U. 12357 A. THE FIGURE FLATTENED
BY PRESSURE OF SOIL. v. p. 121



b. U. 12357 A. THE FIGURE CUT IN HALF
showing the roots of the 'fleece' as attached to the
sides of the body. v. p. 264



c. U. 11164. THE STANDARD AS REMOVED FROM THE GROUND PREPARATORY TO CLEANING
v. p. 61

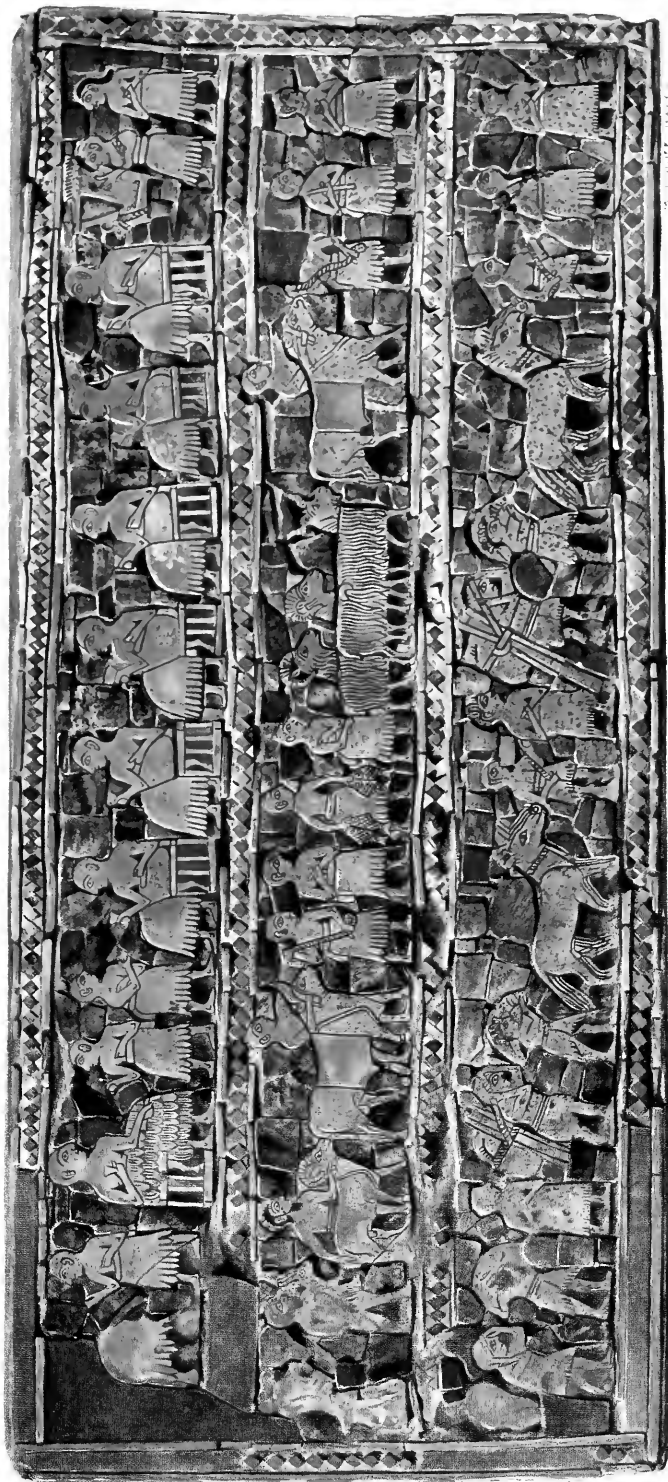

U. 11164. THE 'STANDARD': THE 'PEACE' PANEL

Scale c. $\frac{1}{2}$. r. pp. 61, 266 *et seq.*

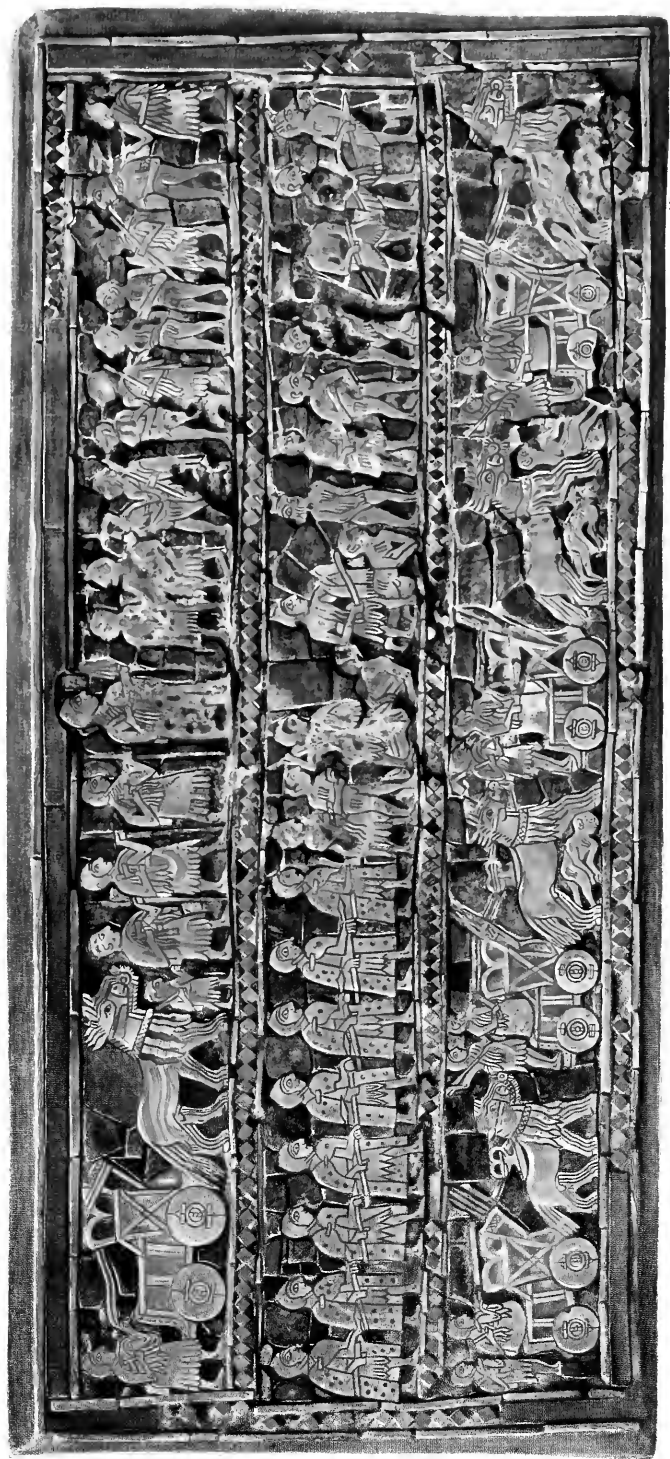

M. LOUISE BAKER

U. 11164. THE 'STANDARD': THE 'WAR' PANEL

Scale c. $\frac{1}{2}$. v. pp. 61, 266 *et seq.*



M. Louise Baker print.

U. 11164. THE 'STANDARD': THE END PANELS
v. pp. 61, 266 *et seq.*



Scale c. $\frac{1}{3}$

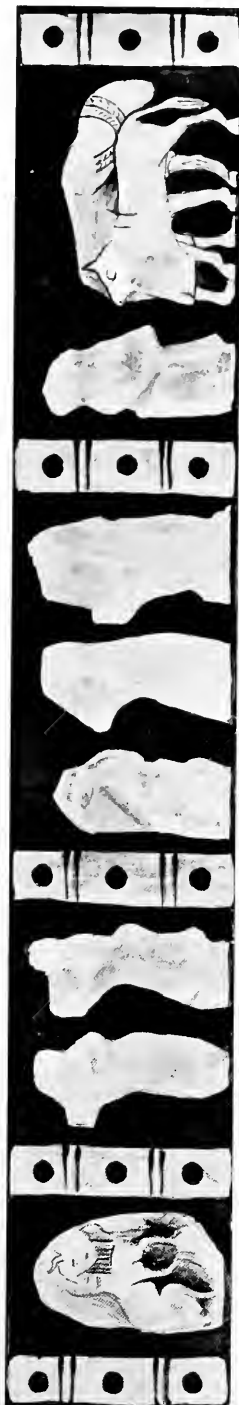
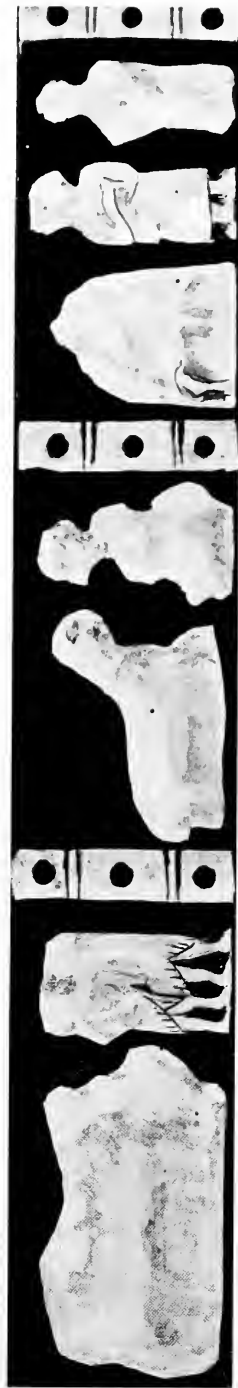

Scale 1

v. p. 80

U. 10441-2. MOSAIC INLAY FROM QUEEN SHUB-AD'S WARDROBE CHEST

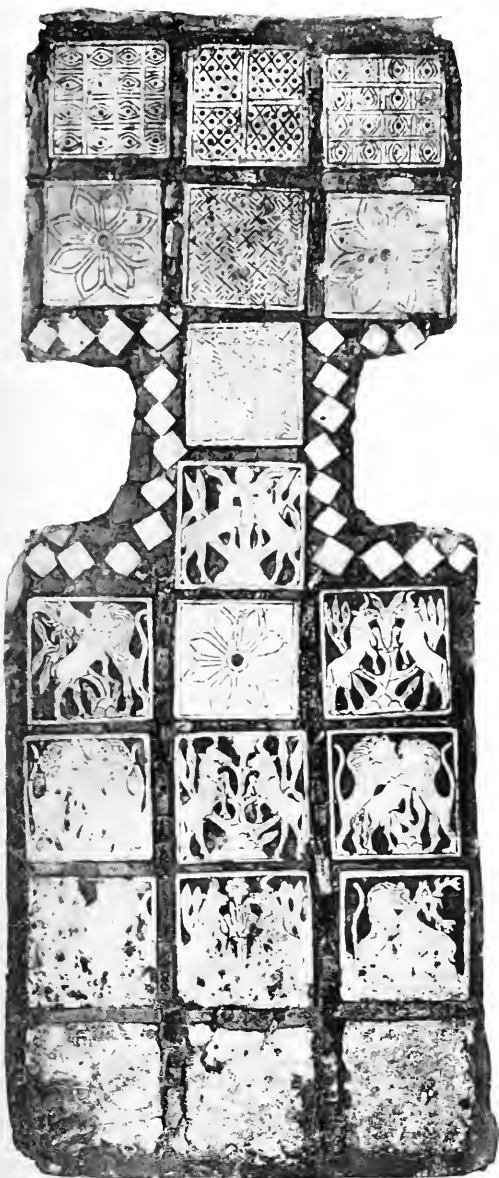

U. 10557. GAMING-BOARD OF SHELL PLAQUES AND LAPIS BORDERS, SET IN SILVER. PG/789
Scale c. $\frac{2}{3}$ v. p. 276



GAMING-PIECES OF PLAIN SHALE AND ENGRAVED SHELL, A COMPLETE SET, FOUND INSIDE THE HOLLOW BOX OF THE BOARD U. 10557

Scale c. $\frac{2}{3}$

v. p. 278

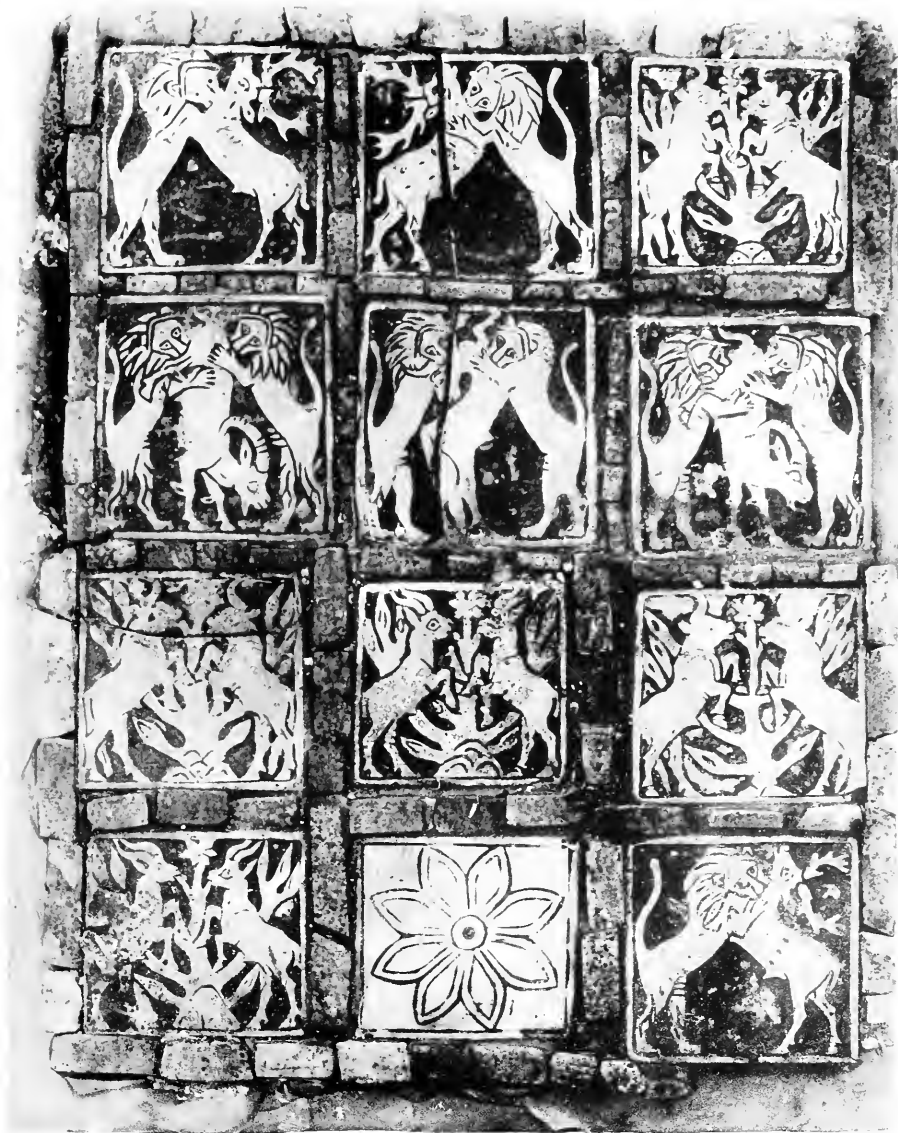

Scale $c. \frac{1}{3}$

U. 11162. PART OF INLAID GAMING-BOARD, SHELL AND LAPIS-LAZULI
PG/779, chamber D. v. p. 277

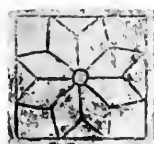

U. 8454



U. 12318



U. 13200



U. 13200

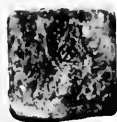

U. 9306



U. 13200



U. 9306

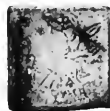

U. 9909

Scale *c.* $\frac{1}{2}$

a

SHELL GAMING-PIECES

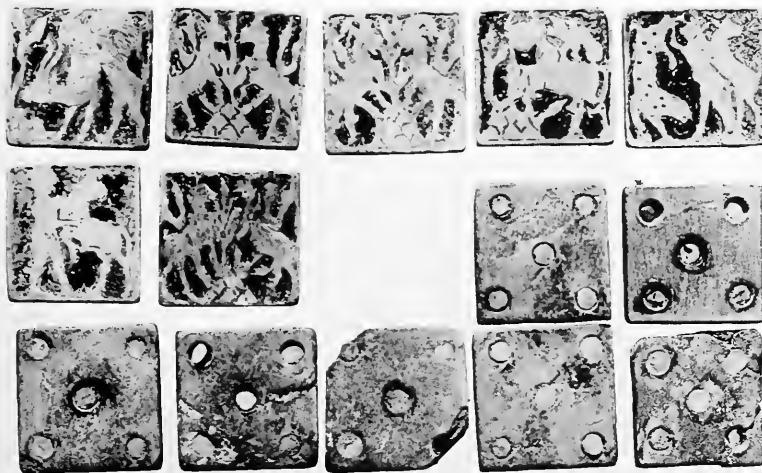

Scale *c.* $\frac{1}{2}$

b

U. 10478. SHELL AND BLACK SHALE GAMING-PIECES

FROM QUEEN SHUB-AD'S GRAVE

v. p. 278



Scale *c.* $\frac{1}{4}$

U. 9905
PG/580

U. 9906
PG/580

a

U. 9907

SHELL CARVINGS



Scale *c.* $\frac{1}{4}$

b

U. 9776
PG/580

ENGRAVINGS ON SHELL

v. p. 278



Scale c. $\frac{1}{4}$ U. 10917 B



Scale c. $\frac{1}{10}$ U. 10917 B



U. 10917 A
v. p. 91



U. 11222



Scale c. $\frac{1}{4}$ U. 10447



Scale c. $\frac{1}{4}$ U. 10412



U. 10412



Scale c. $\frac{1}{4}$ U. 8915 B



U. 8915 A



U. 11862

ENGRAVINGS ON SHELL

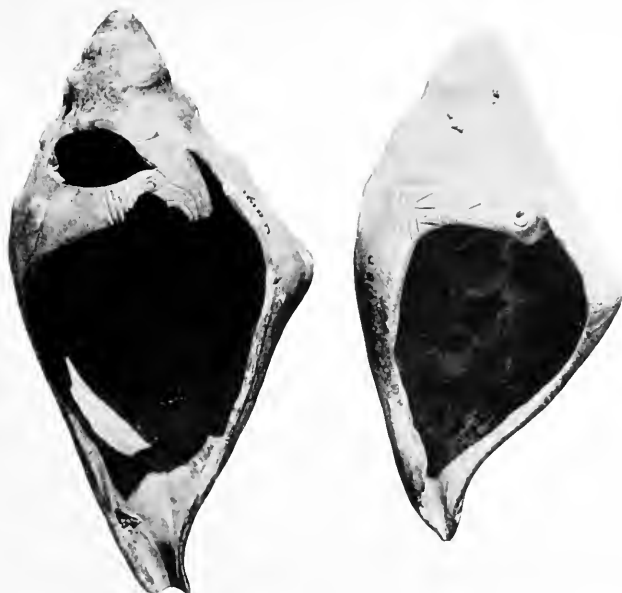

Scale *c.* $\frac{3}{4}$. U. 8191

U. 8198

a. SHELLS CUT TO SERVE AS LAMPS. *v.* p. 283



b. U. 10437. MOTHER-OF-PEARL KNIFE(?) -HANDLE

Scale *c.* $\frac{3}{2}$. PG/800. *v.* p. 282

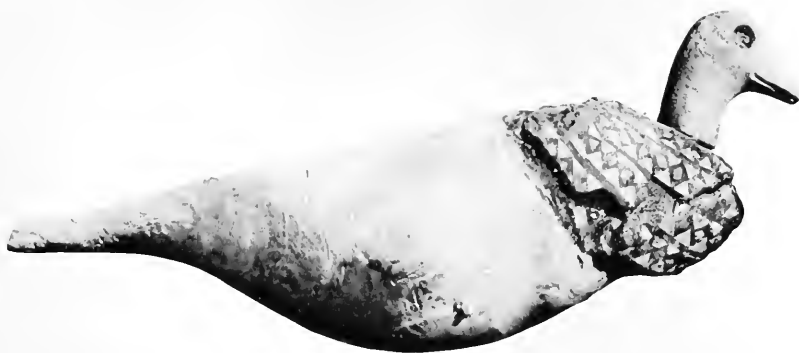

Scale *c.* $\frac{1}{2}$

a. U. 8313. SHELL LAMP (?) WITH ENCRUSTED ORNAMENT
v. p. 282



Scale *c.* $\frac{2}{3}$ *b.* U. 7900. ENGRAVED SHELL PLAQUE
v. p. 282

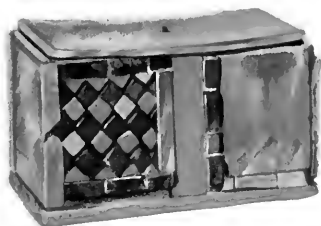

Scale c. $\frac{1}{2}$

U. 14483 A
v. p. 282



Scale c. $\frac{7}{10}$

U. 10436
v. p. 279



Scale c. $\frac{1}{4}$

U. 9112
v. p. 263



Scale c. $\frac{2}{3}$

U. 10988



Scale c. $\frac{1}{4}$

U. 8935
v. p. 261

QUEEN SHUB-AD'S TOILET BOX AND OTHER OBJECTS IN SHELL

M. Louise Baker del.



c. 3. U. 12354. v. p. 253



c. 3. U. 12353. v. p. 252

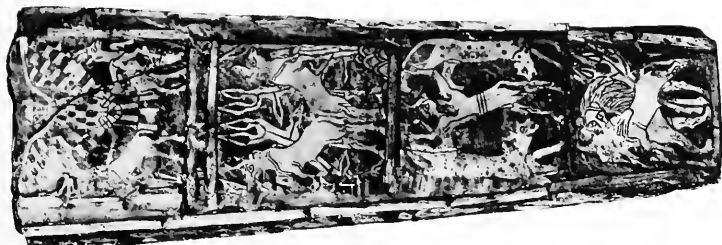

c. 3. U. 10412. v. p. 249



c. 3. U. 10577. v. p. 69

ENGRAVED SHELL PLAQUES FROM THE SOUND-BOXES OF LYRES
v. p. 281



U. 10556

ENGRAVED SHELL PLAQUES
FROM THE LYRE IN PG/789

Scale c. $\frac{1}{4}$. v. p. 280



a. U. 10556. PG/789. THE LYRE *in situ*, SHOWING THE IMPRESSION IN THE SOIL OF THE SOUND-BOX AND BACK UPRIGHT
v. p. 70

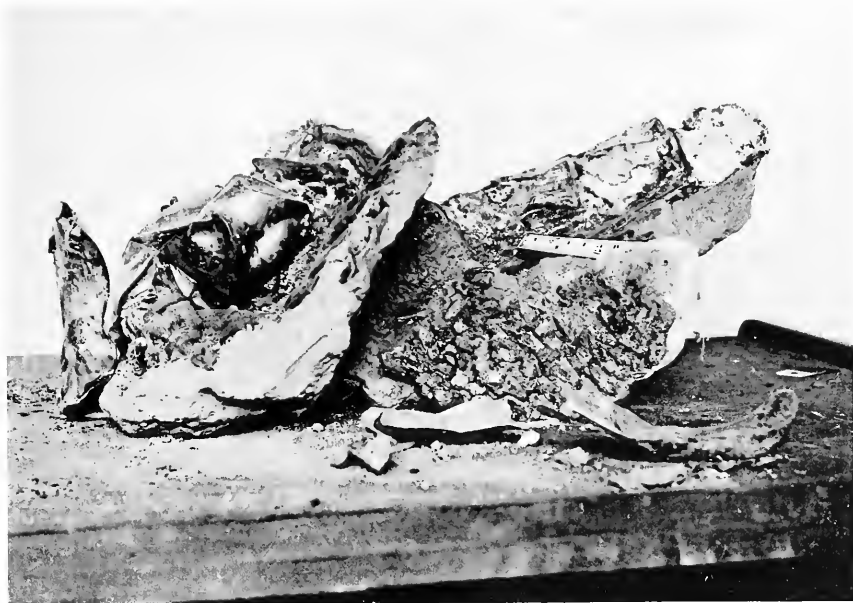

b. U. 10556. THE FRONT OF THE LYRE AS REMOVED, PREPARATORY TO CLEANING
v. p. 70



U. 10556. THE GOLD HEAD OF A BULL WITH LAPIS-LAZULI BEARD FROM THE SOUND-BOX OF THE LYRE (RESTORED). PG/789

Scale $c. \frac{2}{3}$. v. p. 70

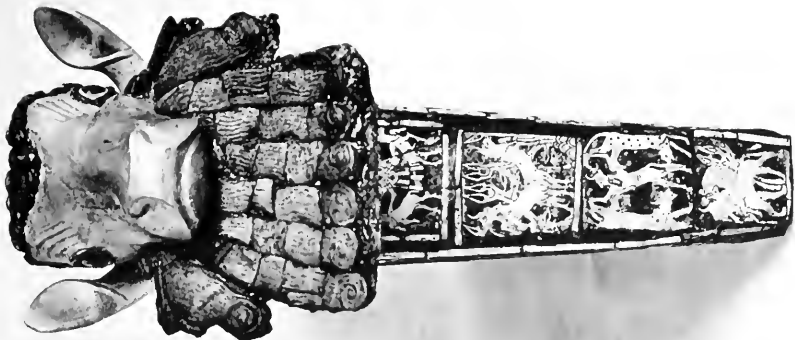

Scale $c. \frac{1}{2}$
 U. 10412. THE FRONT OF THE SOUNDING-BOX OF THE HARP, AS RESTORED

v. pp. 74, 249



PG/800. THE FRONT OF THE SOUNDING-BOX OF QUEEN SHUB-AD'S HARP, IN POSITION, SHOWING THE SHELL PLAQUES AND PART OF THE MOSAIC BORDER

v. pp. 74, 249

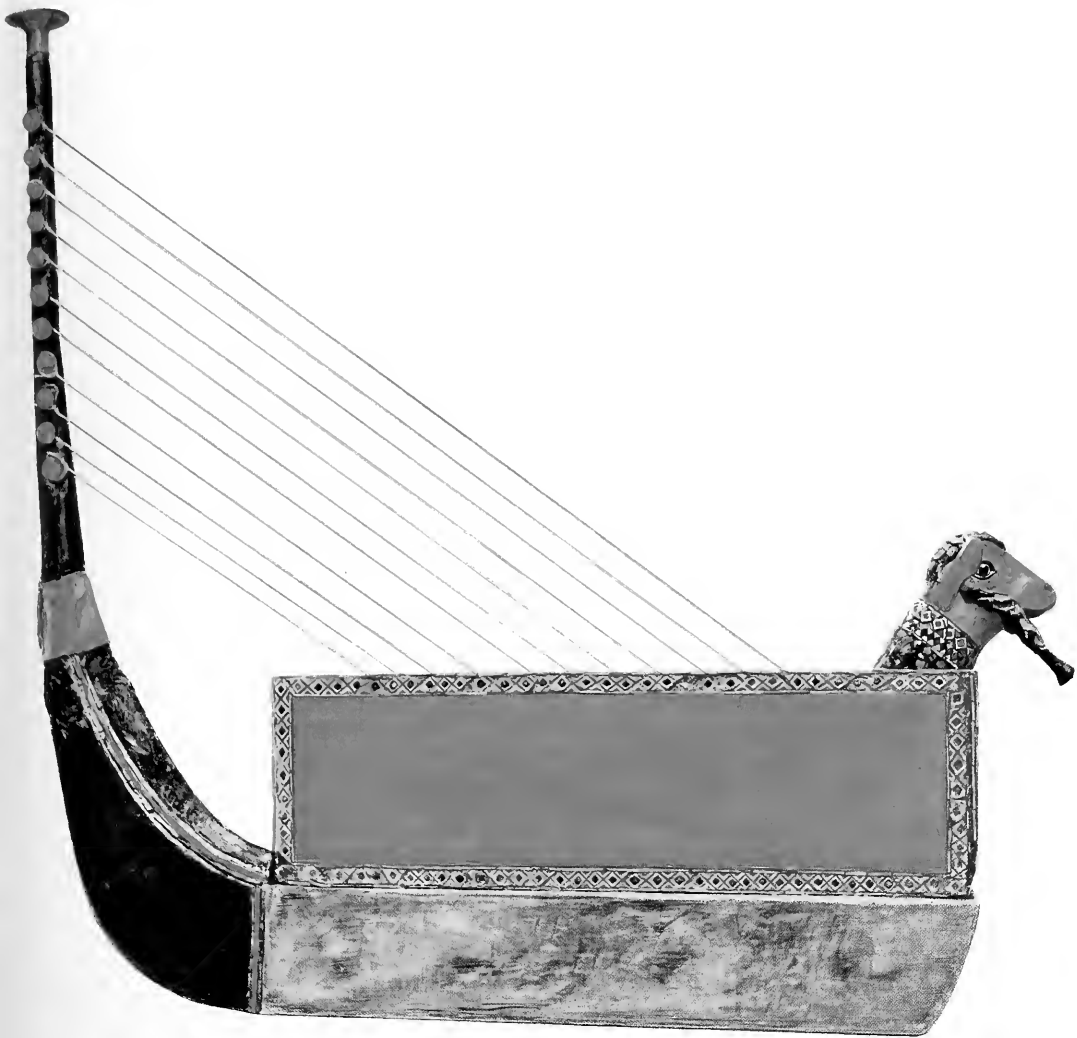

U. 10412. QUEEN SHUB-AD'S HARP (RESTORED)

Scale c. $\frac{1}{3}$ (ht. 1.07 m.)

v. pp. 74, 249 *et seq.*

M. Louise Baker pinx.



U. 10412. QUEEN SHUB-AD'S HARP. DETAIL OF SOUND-BOX

Scale c. $\frac{3}{4}$

v. pp. 74, 249 et seq.

M. Louise Baker pinx.



Scale c. $\frac{1}{3}$ (ht. 1.06 m.)

U. 12354. SILVER LYRE FROM THE GREAT DEATH-PIT, PG/1237

v. p. 253



Scale *c.* $\frac{1}{3}$ (ht. 1.16 m.)

U. 12355. SILVER LYRE FROM THE GREAT DEATH-PIT, PG/1237

v. p. 255



a. U. 12356. COPPER STATUE OF STAGS. PG/1237
Scale c. $\frac{1}{2}$. v. p. 123

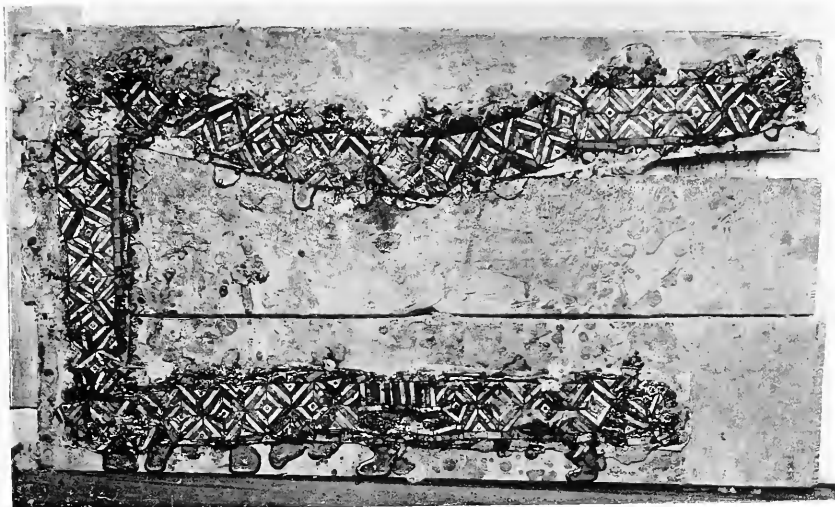

b. U. 12353. THE MOSAIC BORDER OF THE LYRE'S SOUND-BOX AS REMOVED FROM THE SOIL
Scale c. $\frac{1}{2}$. v. p. 252

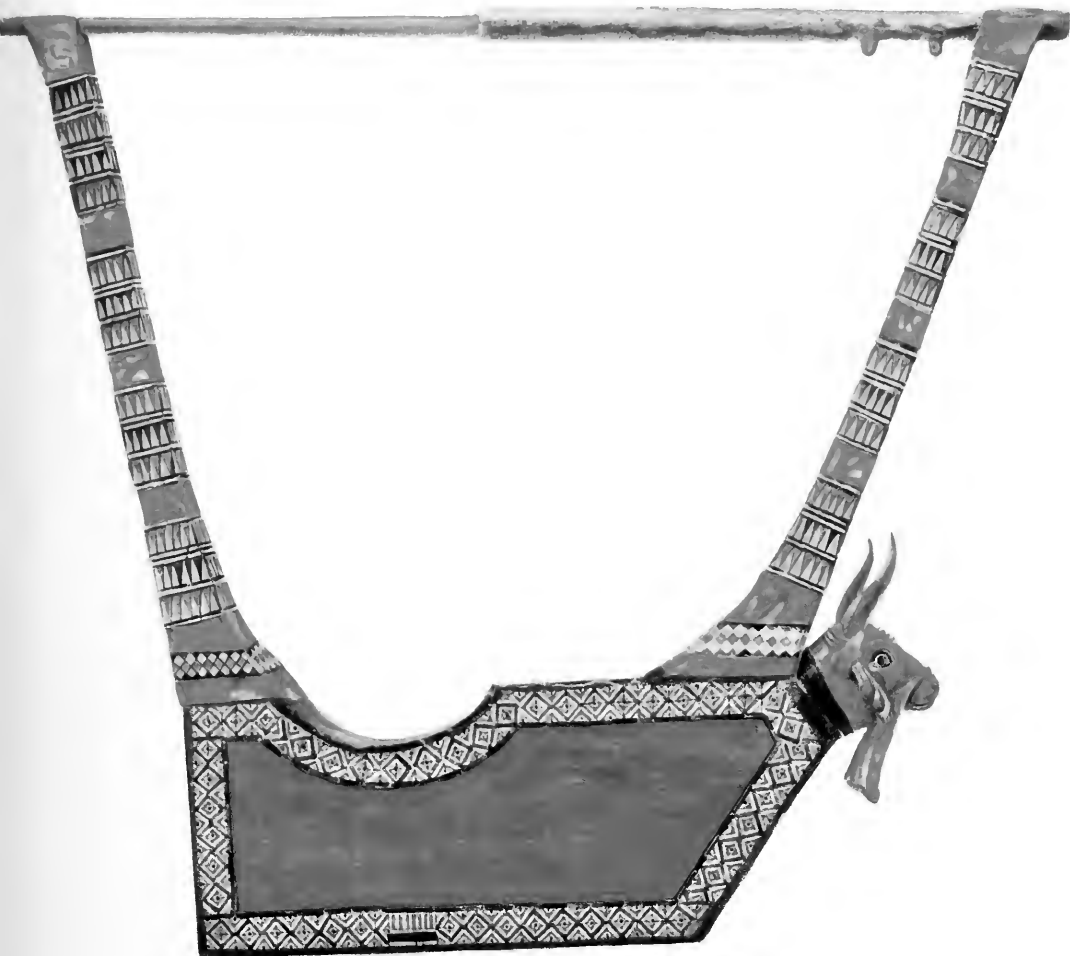

U. 12353. THE GOLD LYRE FROM THE GREAT DEATH-PIT, PG/1237

Scale *c.* $\frac{1}{10}$ (ht. 1.20 m.)

v. p. 252

M. Louise Baker pinx.



U. 12353. THE GOLDEN BULL'S HEAD FROM THE LYRE. PG/1237
Scale c. $\frac{2}{3}$. v. p. 122



U. 12435. COPPER HEAD AND SHELL PLAQUES FROM A LYRE. PG/1332

Scale c. $\frac{2}{3}$

v. p. 126

M. Louise Baker del. et pinx.



U. 12353. GOLD BULL'S HEAD FROM THE LYRE. PG/1237
(THE LEFT HORN IS BENT AS WHEN FOUND)
Scale c. $\frac{2}{3}$. v. p. 252



U. 12435. PG/1332
Scale c. $\frac{1}{2}$. v. p. 126



a

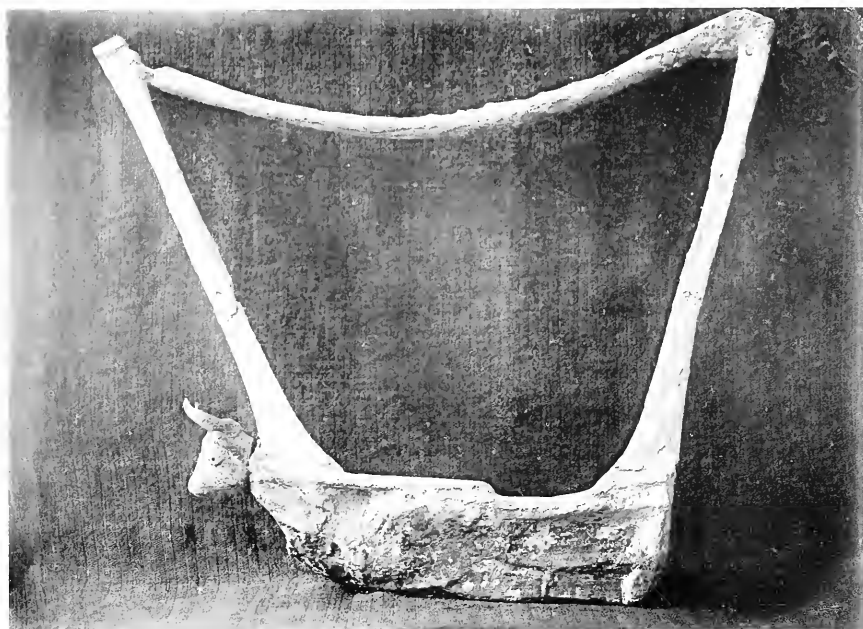

b

Scale c. $\frac{1}{15}$ (ht. 0.90 m.)

PG/1151

a. THE PLASTER CAST OF THE WOODEN LYRE U. 12351 *in situ* AFTER THE EARTH HAD BEEN CUT AWAY ON ONE SIDE. THE WHITE LINES OF THE STRINGS ARE CLEARLY VISIBLE. THE THIRD UPRIGHT WAS NOT ATTACHED TO THE LYRE

b. THE PLASTER CAST OF THE LYRE REMOVED FROM THE SOIL, SHOWING THE BETTER-PRESERVED FACE
v. p. 256



Scale c. $\frac{1}{2}$

a



Scale c. $\frac{1}{2}$

b

U. 12351. THE COPPER BULL'S HEAD AND ENGRAVED SHELL PLAQUE BELONGING TO THE 'PLASTER' LYRE

v. p. 256



a. U. 10916. SILVER COW'S HEAD. PG/800
Scale *c.* $\frac{1}{2}$. v. pp. 91, 301



b. U. 10577. COPPER BULL'S HEAD. PG/789
Scale *c.* $\frac{1}{2}$. v. p. 69



b

U. 11798. COPPER HEAD OF A HORNED DEITY, PERHAPS FROM A LYRE
FOUND LOOSE IN THE SOIL

v. p. 301



a

Scale *c. g.*



Scale *c.* $\frac{3}{20}$ (Ht., excluding runner, 1.15 m.)

RECONSTRUCTION OF THE SLEDGE-CHARIOT OF QUEEN SHUB-AD, U. 10438

v. p. 78



Scale c. $\frac{1}{10}$ (ht. 1.15m.)

a



Scale c. $\frac{1}{4}$

b

PG/800. U. 10438. THE CHARIOT OF QUEEN SHUB-AD

a. THE CHARIOT AS RESTORED (THE RUNNERS ARE NOT SHOWN)

b. THE THREE LIONS' HEADS OF THE SIDE PANEL IN POSITION IN THE EARTH: ONE OF THE SMALL BULLS' HEADS FROM THE TOP RAIL IS ALSO VISIBLE



U. 10438. PANEL OF QUEEN SIUB-AD'S SLEDGE CHARIOT (RESTORED)
r. p. 78

M. Louise Baker photo.

Scale c. 8





Scale *c.* $\frac{1}{4}$



Scale *c.* $\frac{1}{4}$

PG/800. U. 10438. SMALL GOLD HEADS OF BULLS AND LIONS FROM THE TOP BAR OF THE QUEEN'S CHARIOT

v. p. 78



Scale *c.* $\frac{1}{2}$ *a*



Scale *c.* $\frac{1}{2}$ *b*



Scale *c.* $\frac{1}{2}$ *c*

PG/800. U. 10438. THE CHARIOT OF QUEEN SHUB-AD

- a.* One of the lions' heads from the side panel.
- b.* Part of the front bar joining the runners, with the mosaic decoration and one of the two small silver heads with shell and lapis mane (as taken from the soil).
- c.* Two silver lionesses' heads from the front of the chariot.

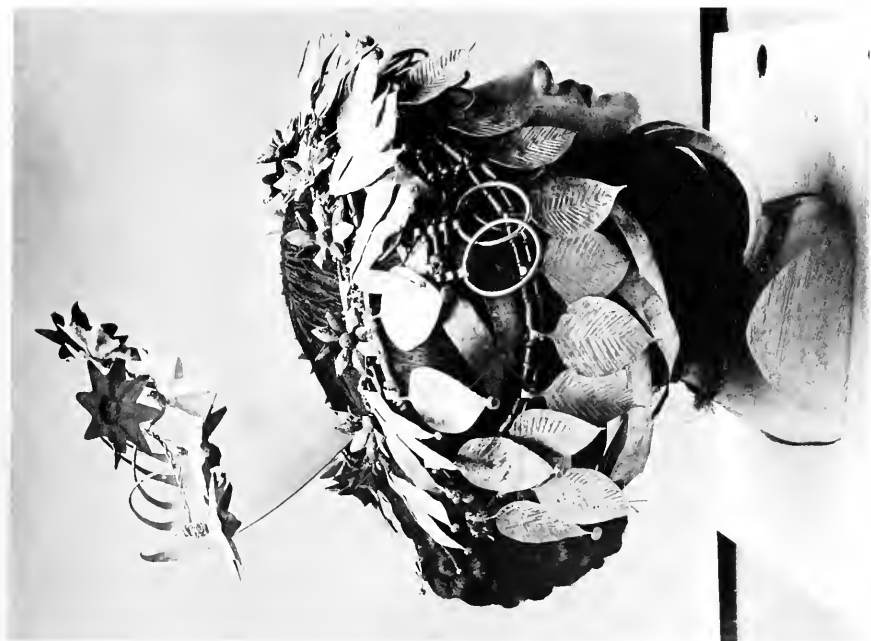

Scale $c. \frac{1}{2}$

U. 10933, ETC. HEAD-DRESS OF QUEEN SHUB-AD, SIDE VIEW
v. p. 84



Scale $c. \frac{1}{2}$

U. 10465. SILVER LIONESS'S HEAD FROM QUEEN SHUB-AD'S GRAVE
v. p. 82



HEAD-DRESS OF QUEEN SHUB-AD, U. 10933, ETC.
Scale c. $\frac{1}{4}$. v. p. 84



ORNAMENTS FROM QUEEN SHUB-AD'S HEAD-DRESS

v. p. 84

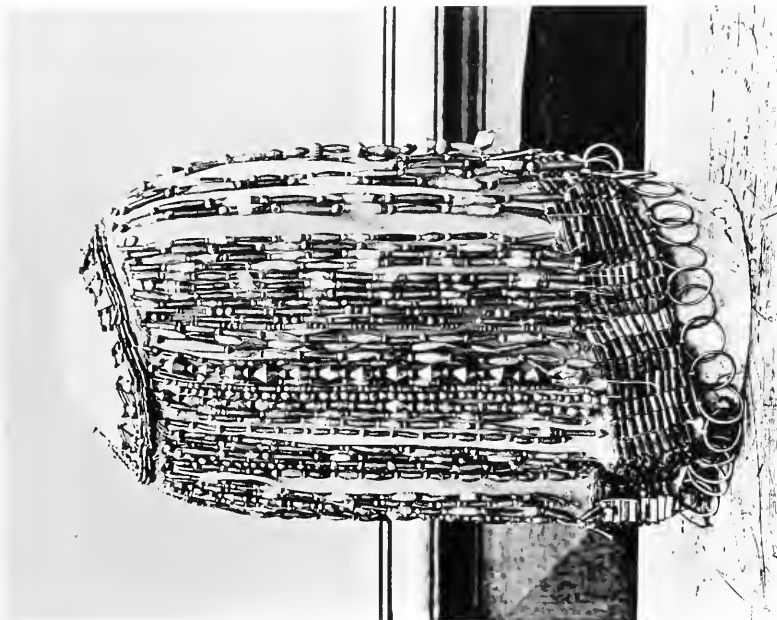

Scale c. $\frac{1}{2}$

U. 10975. ETC. THE BEADS WHICH COVERED THE UPPER PART OF THE
BODY OF QUEEN SHUB-AD, MADE UP AS A CLOAK
v. p. 87



Scale c. $\frac{3}{8}$

U. 10937. THE GOLD FLOWERED HEAD-ORNAMENT OF QUEEN SHUB-AD
v. p. 84

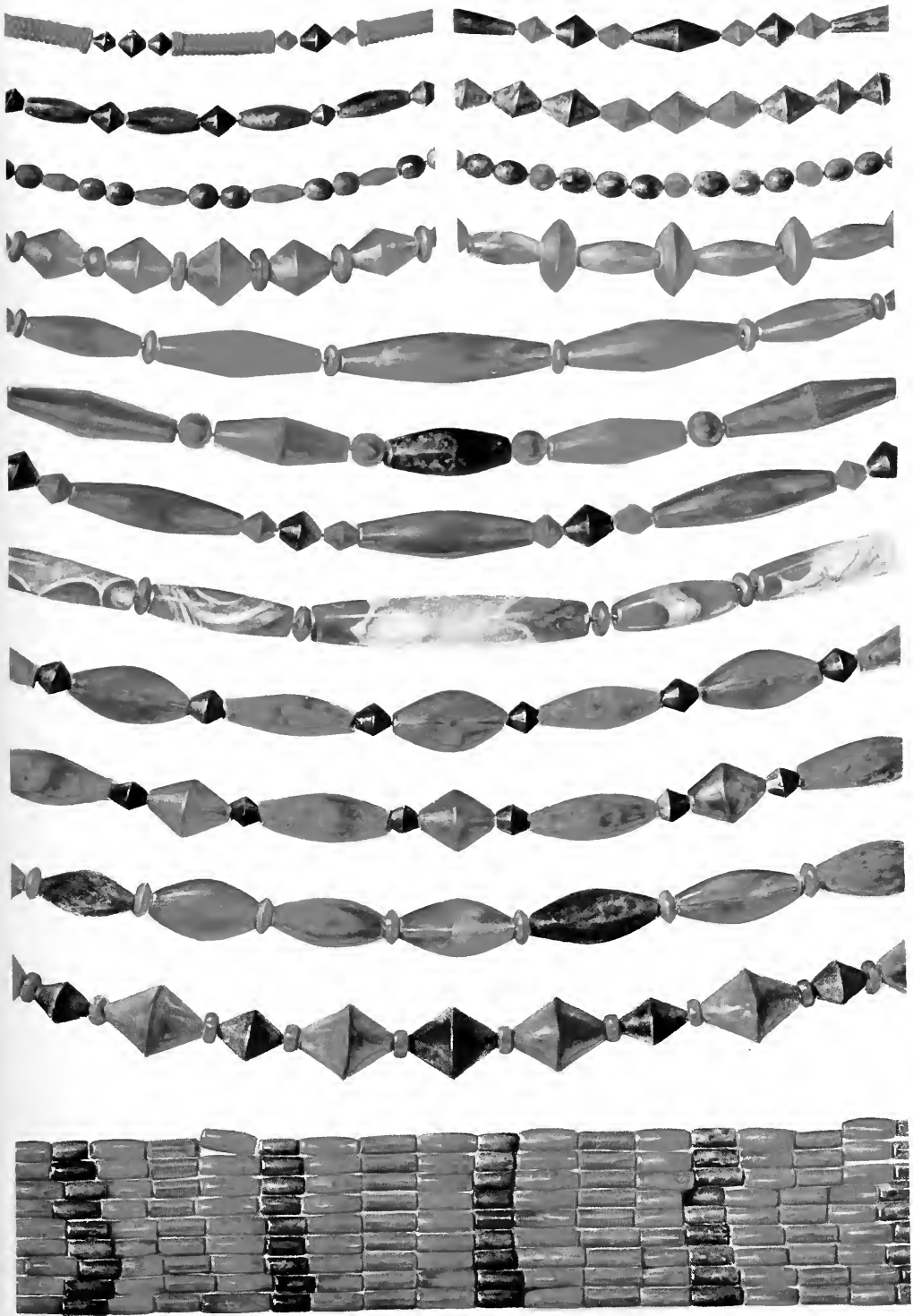

BEADS OF GOLD, LAPIS-LAZULI, AND CARNELIAN FROM THE CLOAK OF
 QUEEN SHUB-AD

Slightly reduced

v. p. 87

M. Louise Baker del.



U. 11910. PG/1054



U. 11728. PG/1116



U. 12450
PG/1236



U. 9164

U. 12474
PG/1422

Scale c. $\frac{2}{3}$.

BEADS
v. p. 185

M. Louise Baker del.



U. 8527

U. 8565



EXAMPLES OF BLEACHED CARNELIAN BEADS

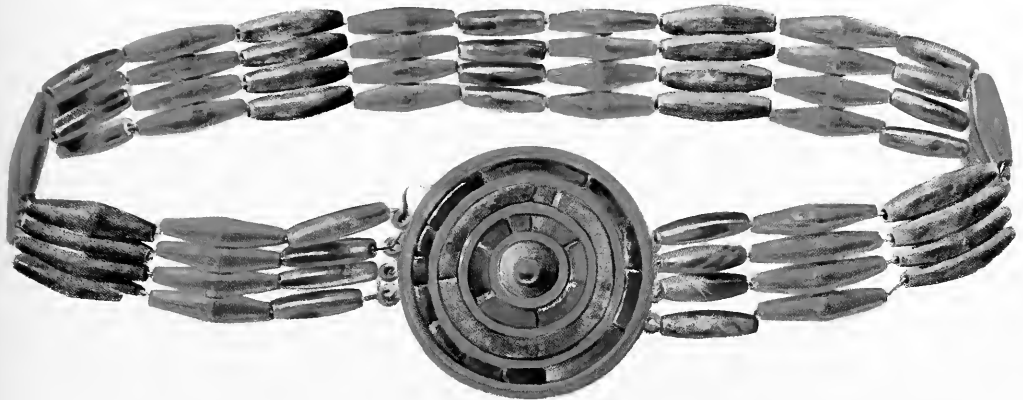

Scale *c.* $\frac{1}{4}$

U. 11806 c, 11807
CHILD'S HEAD ORNAMENT, PG/1133

BEADS

v. pp. 167, 371

M. Louise Baker del.

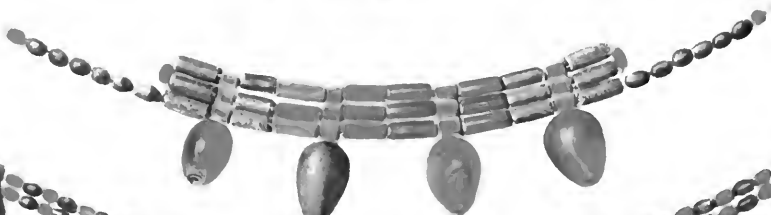
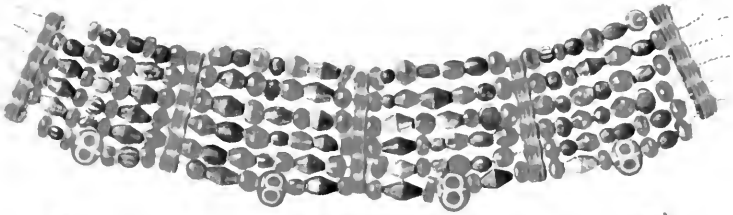

U. 34

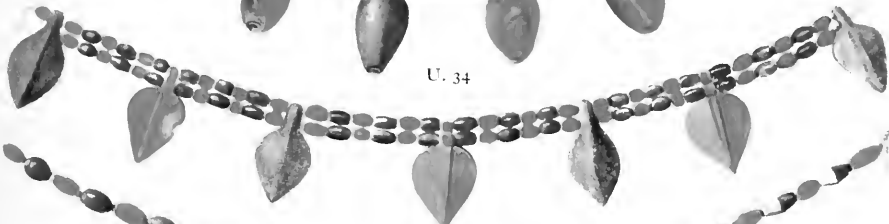

U. 9656

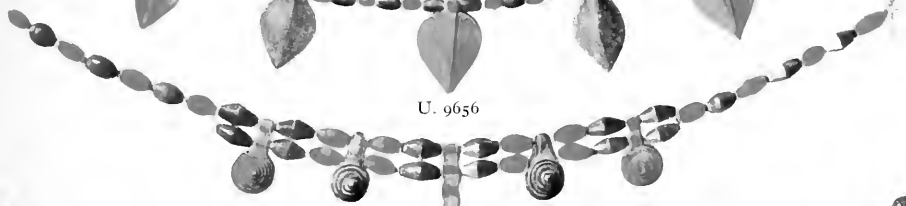

U. 9656

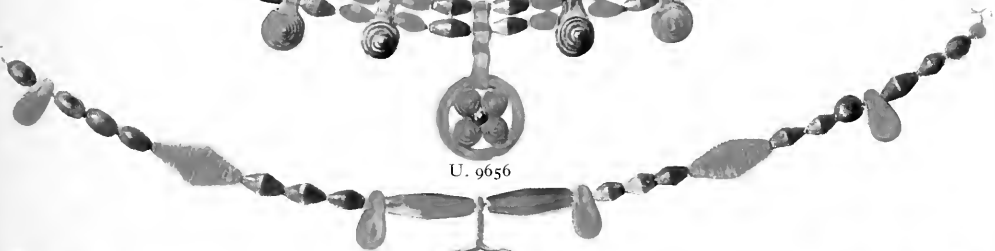

U. 9656



U. 8693



U. 8569

BEADS
v. Ch. xviii

M. Louise Baker del.

U. 11558



U. 12380. HEAD-DRESS OF THE WOMAN NO. 61 IN THE 'GREAT DEATH-PIT', PG/1237
Slightly reduced

v. p. 120 and Pl. 144



SILVER HAIR ORNAMENT. PG/1237

Scale $c. \frac{9}{16}$ v. p. 240



a. U. 8212. SILVER HAIR ORNAMENT
Scale c. $\frac{1}{2}$. v. p. 240



b. U. 9340. GOLD TOILET-SET. PG/580
v. p. 51



c. COCKLE-SHELLS, REAL AND OF SILVER, CONTAINING TOILET PAINT
v. pp. 245, 248



U. 10984

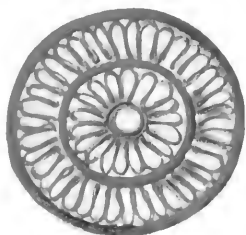

U. 10316



U. 12134

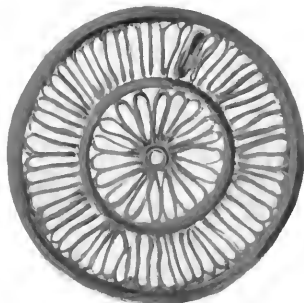

U. 11806 A, B.



U. 11584



U. 10949



U. 10409



U. 10878



U. 9971



U. 9778

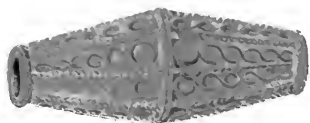

U. 9779



PG/1237

GOLD FINGER-RINGS, EAR-RINGS, ETC.

Scale c. $\frac{1}{2}$, but U. 9779 enlarged by $\frac{1}{3}$.

v. p. 241, &c.

M. Louise Baker del.

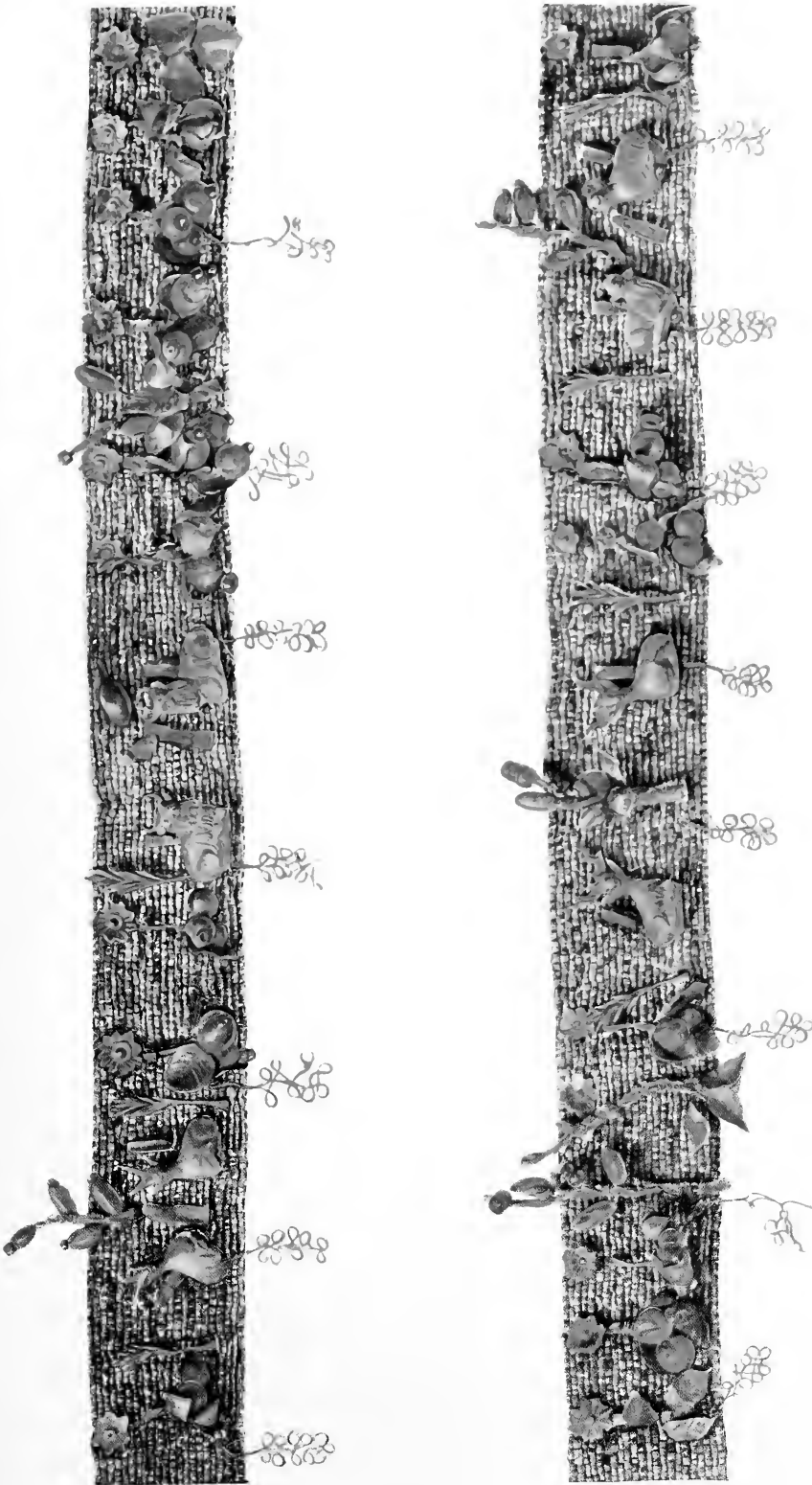

U. 10048. THE DIADEM OF QUEEN SHUB-AD

M. Louise Baker pinx.

v. p. 89

Scale c. 3



Scale c. $\frac{1}{4}$

a



Scale c. $\frac{3}{4}$

b

U. 10948. GOLD ORNAMENTS FROM THE DIADEM OF QUEEN SHUB-AD
v. p. 89



}. U. 9078



}. U. 12469



}. U. 8005



}. U. 2918



}. U. 10943



}. U. 10008



}. U. 10945



}. U. 8033



}. U. 10944



}. U. 11904

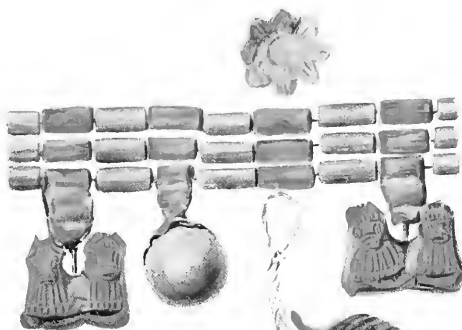

}. U. 11232



}. U. 8368



}. U. 11776



}. U. 10009

AMULETS, ETC.

M. Louise Baker pinx.



c. $\frac{1}{2}$ *a.* U. 10985
PG/800
v. p. 88



b. U. 8642 *c.* $\frac{1}{10}$



c. U. 8269 *c.* $\frac{3}{8}$
v. p. 45

AMULETS



d. U. 10946-7
PG/800
v. p. 88

c. $\frac{1}{2}$



c. $\frac{1}{4}$ *e.* U. 17887. PG/1850. FIRST DYNASTY COPPER BULL'S HEAD
v. p. 212, 215



Scale *c.* $\frac{1}{4}$

PG/1237. U. 12380. HEAD-DRESS OF A WOMAN (BODY 61) FROM THE GREAT DEATH-PIT
v. Pl. 135, and pp. 120, 240

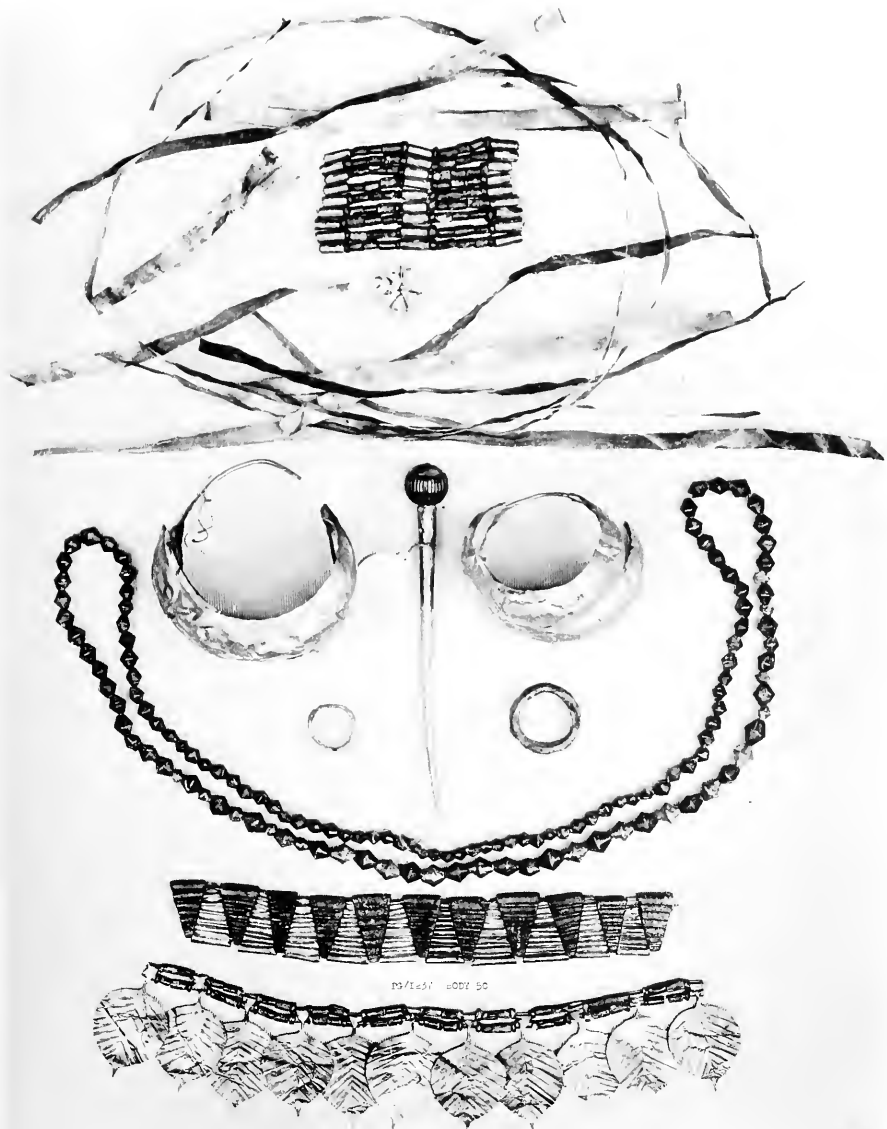

U. 12406. JEWELLERY FROM BODY No. 51. PG/1237
v. p. 119



$\frac{1}{2}$ a. U. 9657. GOLD BEAD
v. p. 371



b. U. 12467. GOLD EAR-RINGS $\frac{1}{2}$

U. 13700

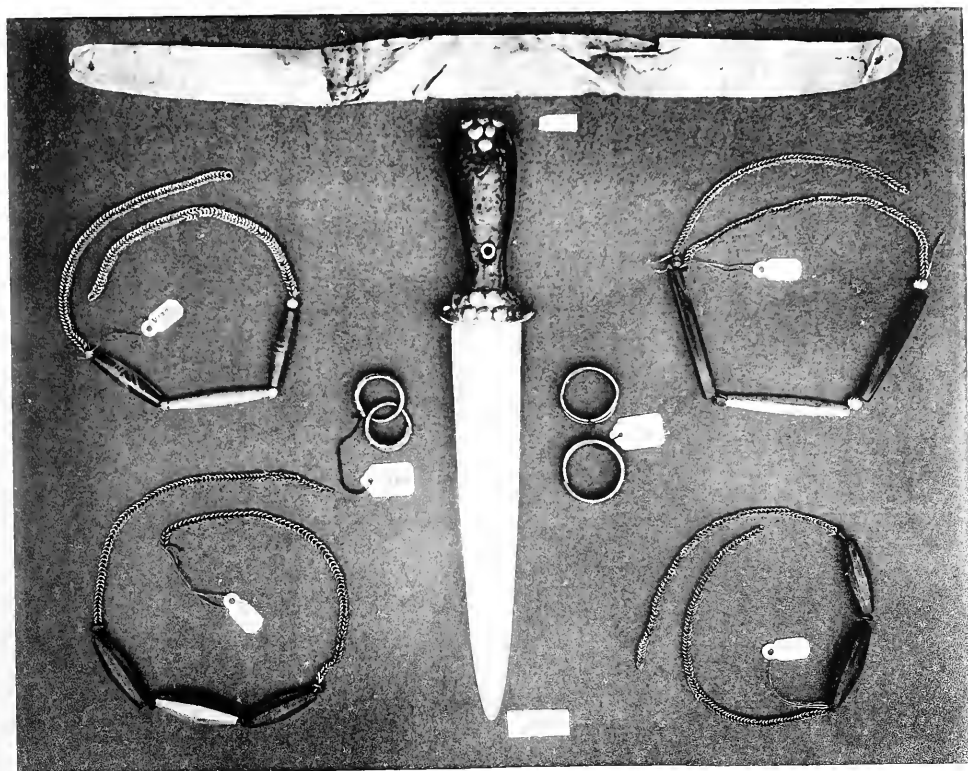

U. 13794
U. 13796 A

U. 13792

U. 13788 U. 13791

U. 13793
U. 13796 B

GOLD OBJECTS FROM PG/1618

Scale c. $\frac{1}{2}$. v. pp. 128, 243

U. 17813. PG/1847
Scale c. 1/2 v. p. 194

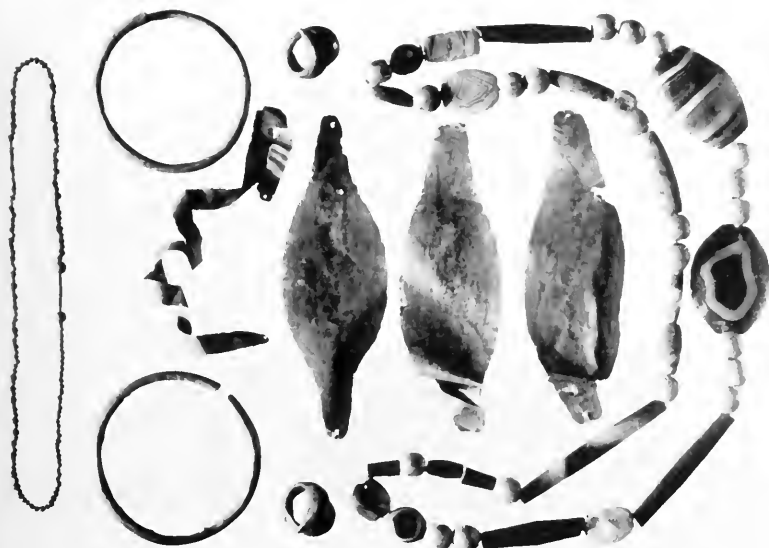

U. 17912. PG/1850
Scale c. 1/2 v. p. 202



OBJECTS FROM SECOND DYNASTY GRAVES

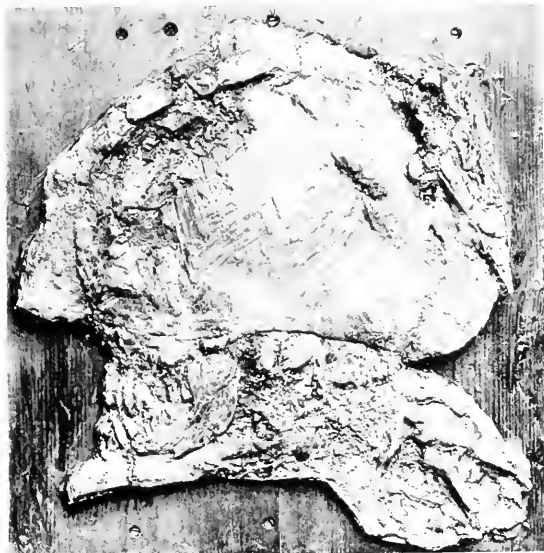

a

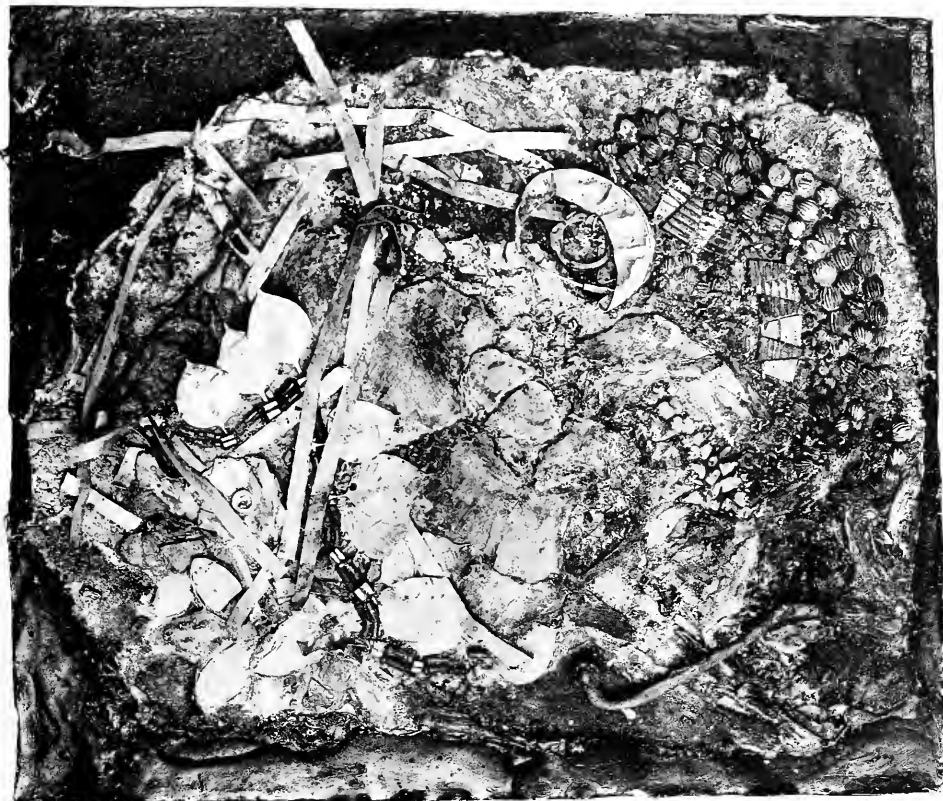

b

a. PG/789. SKULL OF SOLDIER WEARING COPPER HELMET
v. p. 63

b. PG/1237. HEAD-DRESS WAXED AND REMOVED WITH ITS BEADS ETC., IN ORDER
v. p. 116



pc/789. SKULLS OF TWO SOLDIERS WEARING COPPER HELMETS,
FROM THE DROMOS OF THE DEATH-PIT

v. p. 63



U. 10411. GOLD SPEAR-HEADS WITH GOLD AND SILVER
BINDING FROM THE SHAFTS AND A GOLD BUTT WITH
COPPER FORK FOR THE THROWING-STRING

v. p. 68

Scale c. 3



Scale $c. \frac{2}{3}$

a



Scale $c. \frac{2}{3}$ (ht. 0.23 m.)

b

THE GOLDEN HELMET OF MES-KALAM-DUG, FRONT AND BACK VIEWS
v. p. 156



U. 9361
Scale $c. \frac{2}{3}$ v. p. 51

U. 9340
Scale $c. \frac{2}{10}$ v. p. 308

GOLD DAGGER AND TOILET-CASE

M. Louise Baker pinx.



Scale c. $\frac{1}{2}$

U. 10014. PG. 755

U. 10020. PG. 755

A GOLD DAGGER AND A DAGGER WITH GOLD-PLATED HANDLE

v. pp. 156, 159, 308



U. 12442
PG/1236
Scale c. $\frac{1}{2}$. v. p. 113

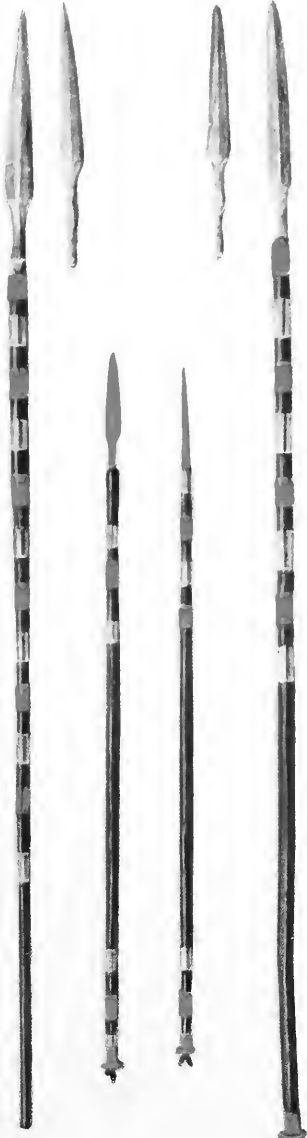

Scale c. $\frac{1}{8}$

U. 10411
PG/789

U. 10472
v. p. 309



U. 9333, 9335
PG/580
v. p. 305

GOLD MOUNTED SCEPTRE, SPEARS, AND AXE

M. Louise Baker del.

U. 10049

U. 10047

U. 10023

U. 10044



Scale c. $\frac{1}{4}$

a



U. 10005

U. 10020

U. 10019

Scale c. $\frac{1}{4}$

b

PG/755. GRAVE OF MES-KALAM-DUG

a. SPEARS AND A HARPOON: THE SPEAR U. 10023 HAVING A GOLD MOUNT JOINTED IN IMITATION OF BAMBOO

b. DAGGER WITH GOLD HANDLE, GOLD PIN WITH LAPIS-LAZULI HEAD, AND GOLD HAIR-RINGS
v. pp. 155, 308



U. 10015

U. 10014

Scale c. $\frac{1}{2}$

a

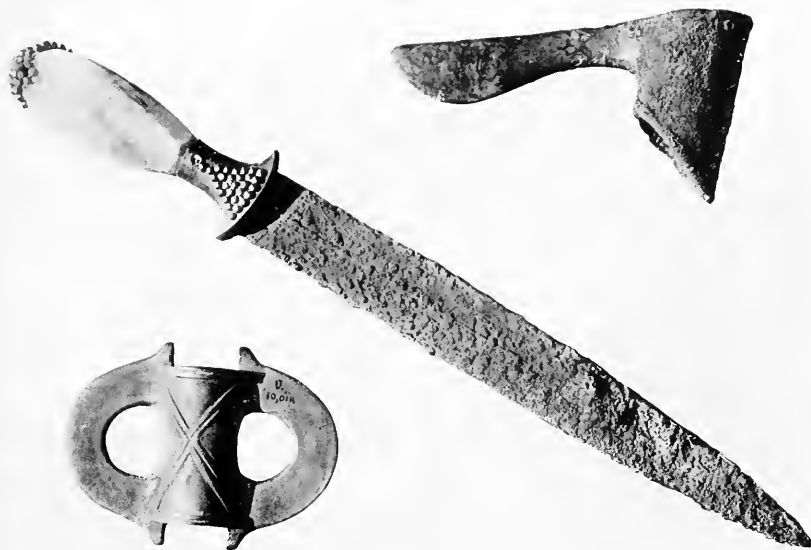

U. 10025

U. 10021

Scale c. $\frac{2}{3}$

b

PG/755. GRAVE OF MES-KALAM-DUG

- a. Dagger with gold blade and gold-mounted wooden handle (the wood restored), with remains of silver sheath, and lapis-lazuli whetstone
- b. Dagger with bronze blade and silver handle mounted with gold (the silver restored), and two electrum axes

U. 10018



Scale c. $\frac{1}{2}$

U. 10018
v. pp. 156, 306



Scale c. $\frac{3}{4}$

U. 9255
v. p. 283

ELECTRUM DOUBLE AXE AND OSTRICH SHELL WITH MOSAIC INCRUSTATION

M. Louise Baker del.



a
GOLD-MOUNTED DAGGER
U. 10553 (PG/789). v. p. 65



b
GOLD DAGGER-BLADES
U. 11513 U. 11512
(PG/1054). v. p. 98

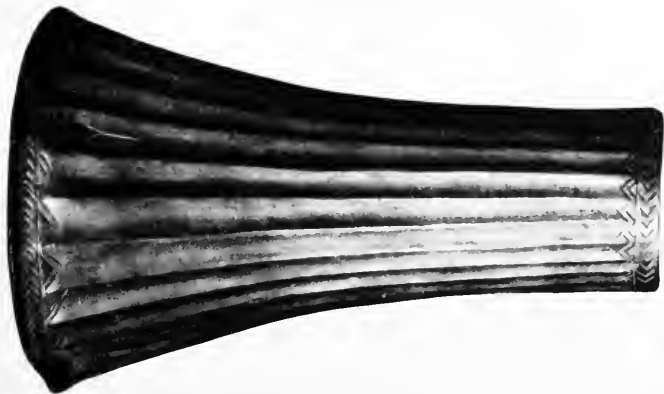

c
FLUTED GOLD TUMBLER
U. 11902 (PG/1054). v. p. 106.



Scale *c.* $\frac{1}{2}$

a

U. 10478. DICE OF LAPIS AND GOLD AND OF SHELL AND LAPIS, FROM QUEEN SHUB-AD'S GRAVE
v. p. 278



Scale *c.* $\frac{1}{3}$

b

U. 10429

U. 10432

U. 10431

U. 10433

U. 10428

U. 10430

GOLD SAW AND CHISELS, FROM QUEEN SHUB-AD'S GRAVE

v. p. 303



Scale *c.* $\frac{1}{2}$

a



Scale *c.* $\frac{7}{10}$

b



Scale *c.* $\frac{1}{2}$

U. 10013
Type 4

c

U. 10034
Type 9

a. SILVER PIN, U. 8598; *v.* pp. 241, 310

b. GOLD AND LAPIS CHAIN, U. 8002; SILVER TOILET-SET, U. 9362

c. ELECTRUM BOWLS FROM THE GRAVE OF MES-KALAM-DUG; *v.* p. 159.

*a**b*Scale *c.* $\frac{1}{2}$ *a.* GOLD GOBLET FROM QUEEN SHUB-AD'S GRAVE, PG 800*b.* GOLD BOWL FROM PG 755 (TOMB OF MES-KALAM-DUG)

c. p. 159



Scale $c. \frac{1}{4}$

GOLD VESSELS U. 10454 (TYPE 91) AND U. 10851 (TYPE 7) FROM QUEEN SHUB-AD'S GRAVE



Scale c. $\frac{3}{4}$

U. 10004
U. 10002
U. 10001

GOLD VESSELS FROM MES-KALAM-DUG'S GRAVE. PG/755

v. p. 156



Scale c. $\frac{1}{3}$

U. 10930
U. 10451

GOLD VESSELS FROM QUEEN SHUB-AD'S GRAVE. PG/800

v. pp. 82, 91



Scale $c. \frac{1}{2}$

U. 11551, PG 1068
(Type 16 variant)

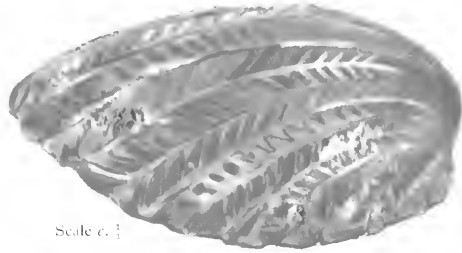

Scale $c. \frac{1}{2}$

U. 10932, PG 800
c. p. 245



Scale $c. \frac{2}{3}$

U. 10488, PG 800 (Cf. metal Type 7)



U. 10010, PG/755
c. p. 300

U. 9339, PG/580

U. 10938, PG 800
c. p. 241

GOLD CUP FROM THE GRAVE OF THE 'LITTLE PRINCESS' PG/1068, GOLD COCKLE-SHELL AND OBSIDIAN
BOWL FROM QUEEN SHUB-AD'S GRAVE
GOLD MONKEY OF MES-KALAM-DUG, GOLD ADZE AND PIN

Scale $c. \frac{2}{3}$



U. 10439

THE REIN-RING AND 'MASCOT' OF QUEEN SHUB-AD'S SLEDGE CHARIOT

Scale $c. \frac{1}{4}$

v. p. 78

M. Louise Baker del.



Scale *c.* $\frac{2}{3}$

a



Scale *c.* $\frac{1}{3}$

b

a. U. 10551. SILVER REIN-RING FROM PG/789
v. p. 301

b. U. 11794. SILVER BOWL WITH DESIGN IN RELIEF OF WILD GOATS IN A ROCKY LANDSCAPE
(THE BOWL IS STUCK ON TO A COPPER BOWL OF WHICH THE RIM SHOWS ABOVE)

Cf. Pl. 217



a



b

Scale $c. \frac{1}{2}$

U. 8013. SILVER HEAD OF ANTELOPE FROM PG/55 (a) BEFORE AND (b) AFTER CLEANING

v. p. 301

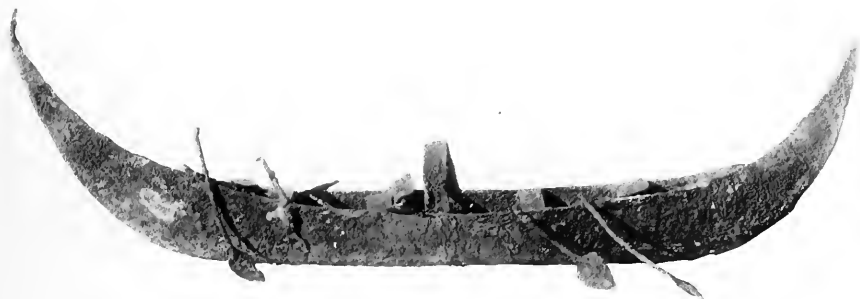

Scale *c.* $\frac{1}{3}$

a. U. 10566. SILVER MODEL OF A BOAT. PG/789
v. p. 71

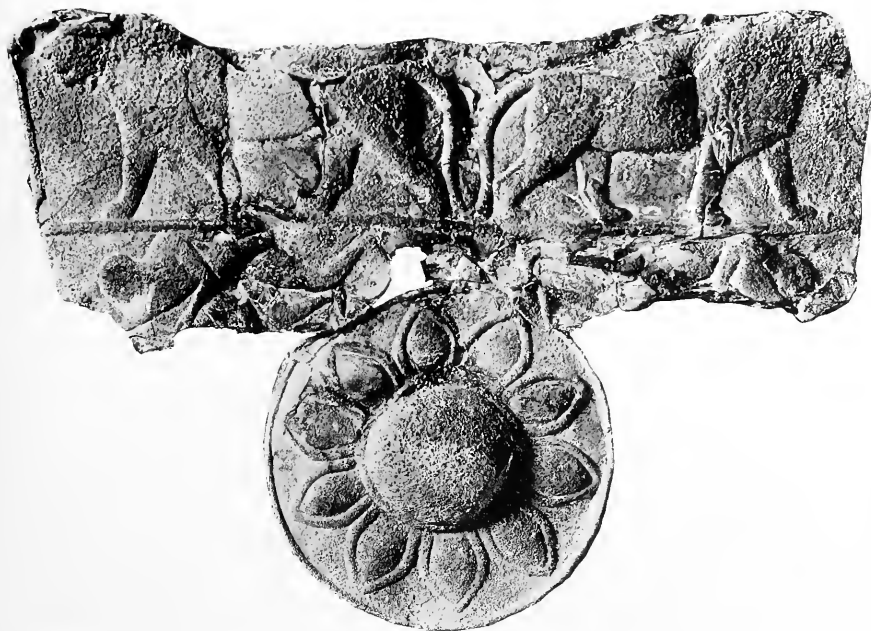

Scale *c.* $\frac{1}{3}$

b. U. 10475. COPPER RELIEF, PERHAPS FROM A SHIELD. PG/789
v. p. 69



a. U. 11154. GOLD COPY OF AN OSTRICH SHELL WITH MOSAIC DECORATION
Scale *c.* $\frac{7}{16}$. *v.* p. 283



b. U. 9364. SILVER LAMP (?)
Scale *c.* $\frac{1}{16}$. *v.* p. 293



a



b

SILVER VESSELS

a. LIBATION JUG U. 11837 (TYPE 84) FROM PG/1142

b. BOWL U. 10554 (TYPE 7) FROM PG/800 WITH ELECTRUM HANDLES AND BULL'S HEAD ENGRAVED ON SIDE

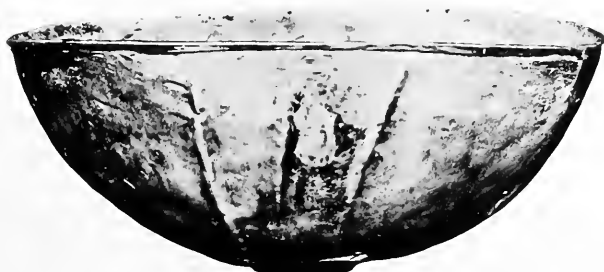
Scale *c.* $\frac{1}{4}$ *a*Scale *c.* $\frac{1}{3}$ *b*Scale *c.* $\frac{1}{3}$ *c*

a. SILVER EWER AND COPPER PATEN, U. 10035 (TYPE 84), U. 10036 (TYPE 30), FROM THE GRAVE OF MES-KALAM-DUG

b. FLUTED SILVER BOWL, U. 9797 (TYPE 89), FROM PG/777

c. SILVER VESSELS, TUMBLERS, EWER, AND PATEN, U. 10458, FROM QUEEN SHUB-AD'S GRAVE

v. p. 78



Scale *c.* $\frac{1}{2}$

U. 10886. PG/800
(Type 115)

a

U. 10456. PG/800
(Type 83)



Scale *c.* $\frac{1}{2}$

U. 10891. PG/800
(Type 7)

b

U. 11821. PG/1133
(Type 7)

SILVER VESSELS FROM THE TOMB OF QUEEN SHUB-AD AND PG/1133

U. 10891 is decorated with electrum ribbons sweated to the silver, *v.* p. 297; U. 11821 has electrum handles



Scale c. $\frac{1}{4}$

LAPIS-LAZULI CUP U. 10517 (TYPE 44) AND CALCITE BOWL U. 10480 (CF. METAL TYPE 7) FROM PG/800;
LAPIS-LAZULI WHETSTONE U. 10552 FROM PG/789



Scale c. $\frac{1}{4}$

U. 10882. JAR OF VEINED CALCITE
PG/800. Type 76 (variant)

M. Louise Baker del.



U. 7840: inscribed calcite bowl. PG/33
Scale *c.* $\frac{1}{2}$



U. 9363
(Type 73)



U. 11818

U. 11589
PG/1100

U. 11898
PG/1172

U. 12696
PG/1395

U. 11786
PG/1130

U. 12673
PG/1382

U. 12492
PG/1137

Scale *c.* $\frac{1}{4}$

v. Chapter xix

STONE VESSELS



Scale $c. \frac{1}{10}$

U. 8980, Type 62
PG/511

U. 8949, Type 3
PG 497

U. 8948, Type 72
PG. 497

U. 8936, Type 92
PG. 497

a



Scale $c. \frac{1}{10}$

U. 8239, Type 82
PG/169

U. 8135, Type 50
PG/135

U. 8190, Type 22
PG/143

U. 8032, Type 60
PG/71

b

EXAMPLES OF STONE VESSELS

v. p. 378

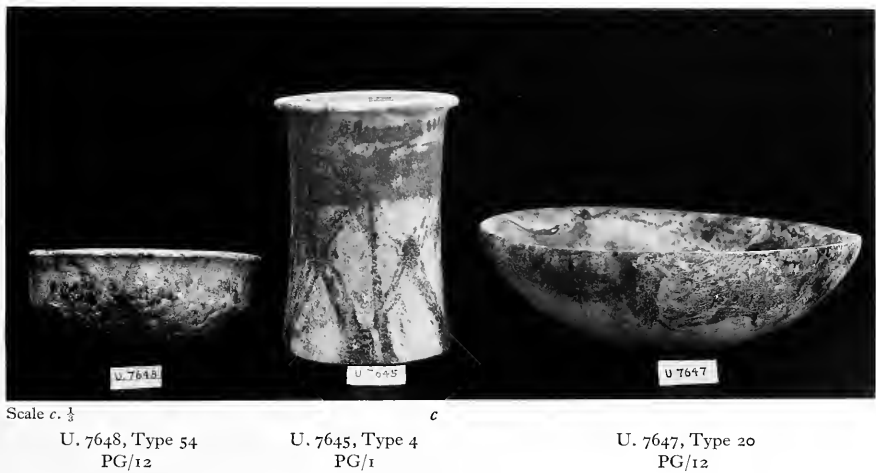
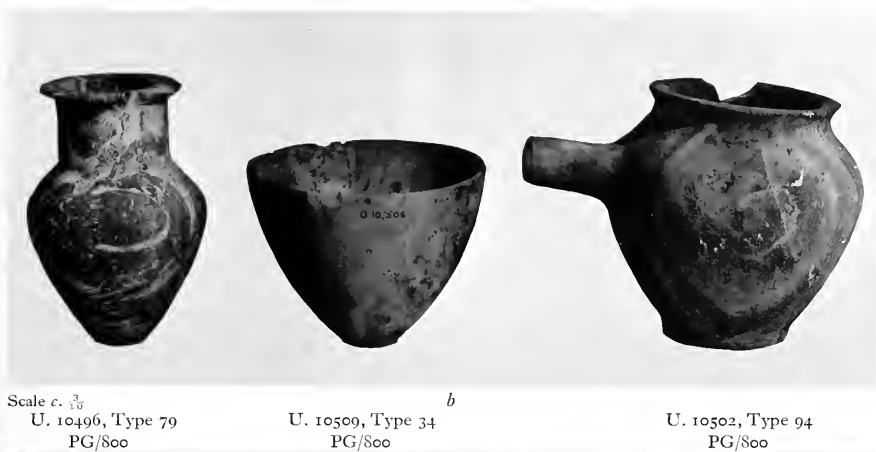

EXAMPLES OF STONE VESSELS
v. p. 378 et seq.



Scale *c.* $\frac{2}{3}$

U. 8331
Type 7
PG/201

a

U. 8380
Type 91
PG/225

U. 8387
Type 80
PG/227



Scale *c.* $\frac{1}{2}$

b

U. 8245
Type 243
Loose in soil

c

U. 8217
Type 101
PG/159

a. EXAMPLES OF STONE VESSELS

b. CLAY OFFERING-TABLE DECORATED WITH INCISED PATTERNS AND ANIMAL FIGURES MODELLED IN THE ROUND

c. LIMESTONE OFFERING-TABLE
v. p. 378 *et seq.*



a. ALABASTER RELIEF FOUND AT KHAFAJE
 (By courtesy of the Oriental Institute of the University of Chicago)



Scale c. $\frac{1}{2}$

b. U. 8557. LIMESTONE SLAB WITH REMAINS OF A RELIEF IDENTICAL
 WITH THAT FROM KHAFAJE

v. p. 376



Scale c. $\frac{3}{8}$

(a) U. 10746



Scale c. $\frac{3}{8}$

(b) U. 11795

LAMPS OF WHITE CALCITE
v. p. 377



Scale $c. \frac{1}{2}$

a

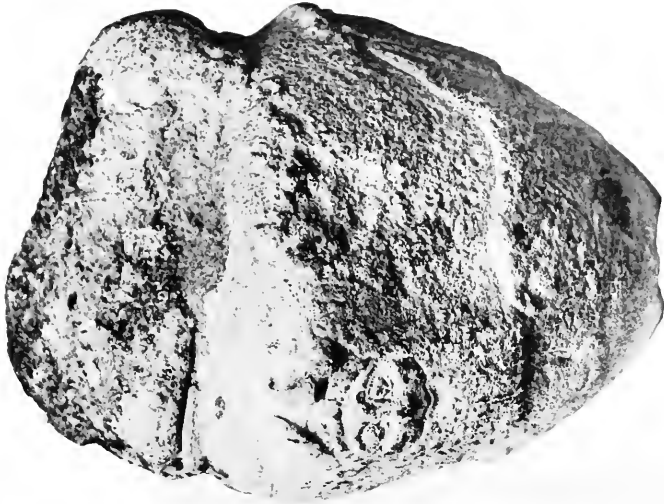

b



c

U. 11678. DECORATED AND INSCRIBED MACE-HEAD OF GYPSUM
v. p. 378

Scale c. $\frac{1}{4}$ *a*Scale c. $\frac{1}{3}$ *b*

EXAMPLES OF COPPER VESSELS

a. Ribbed copper tray, pan, bowls, and vases, U. 12485, from PG/1422

b. Fluted bowl (U. 11950, Type 71) from PG/1186 and bucket (U. 11937, Type 50) from PG/1183

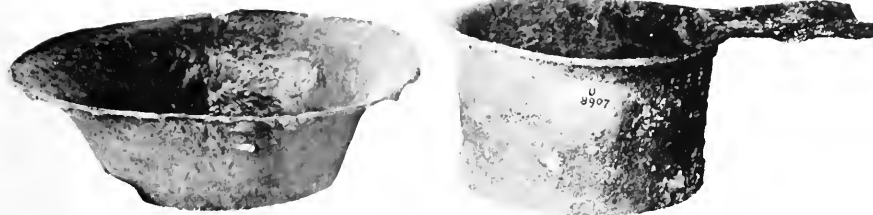

Scale *c.* $\frac{1}{4}$

U. 8626
Type 23
PG/337

a

U. 8907
Type 18
PG/431



Scale *c.* $\frac{1}{4}$

PG/3
Type 23

b

PG/2
Type 22

EXAMPLES OF COPPER VESSELS

v. p. 302



a



b

U. 11838. CLAY POT WITH DESIGN PAINTED IN RED AND BLACK ON BUFF CLAY
Scale *c.* $\frac{1}{2}$ v. p. 387



a. U. 10747. CLAY VASE HANDLE IN THE FORM OF A WOMAN
pg. 805
v. pp. 162, 388

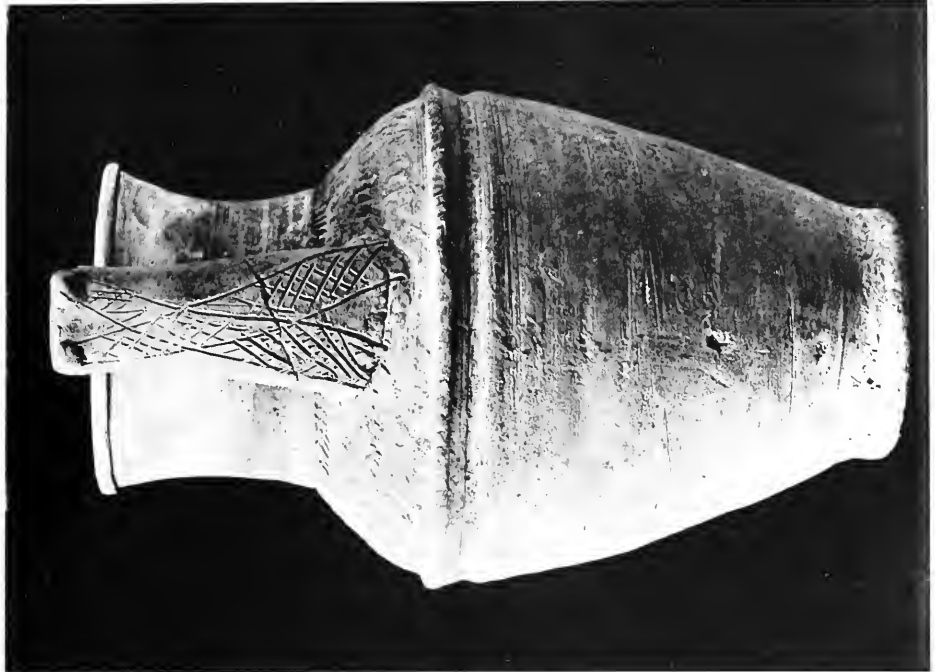

b. U. 10183. CLAY VASE WITH DECORATED HANDLE RECALLING THE HUMAN TYPE.
pg. 778
v. pp. 162, 388



Scale $c. \frac{2}{3}$

a

U. 14461. CLAY ZOOMORPHIC VASE
v. p. 389



b

IMPRINT IN THE SOIL OF A CIRCULAR BASKET OF WOVEN FIBRE. FIRST DYNASTY LEVEL
v. p. 139

Scale *c.* $\frac{5}{16}$ *a**b* Scale *c.* $\frac{1}{4}$

a. U. 10825-8. SPEAR-BLADES WITH ENGRAVED MARKS, FROM PG/789
v. pp. 63-4, 304

b. U. 8014. SILVER PIN, PG/55
v. p. 310

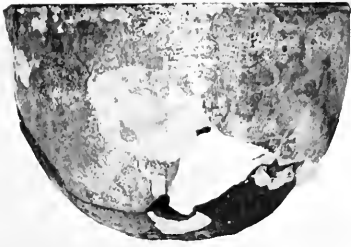

a
U. 10081, v. p. 316



b
U. 7994

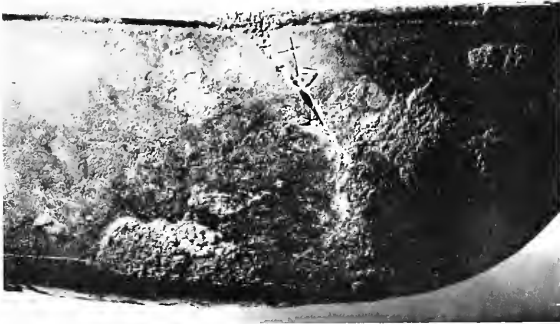

c
U. 7994



d
L. BM. 120732, l. 0.137 m., d. 0.039 m.
L. BM. 120731, l. 0.30 m., d. 0.027 m.



e
U. 9361
v. p. 317

ENGRAVED MARKS ON METAL OBJECTS

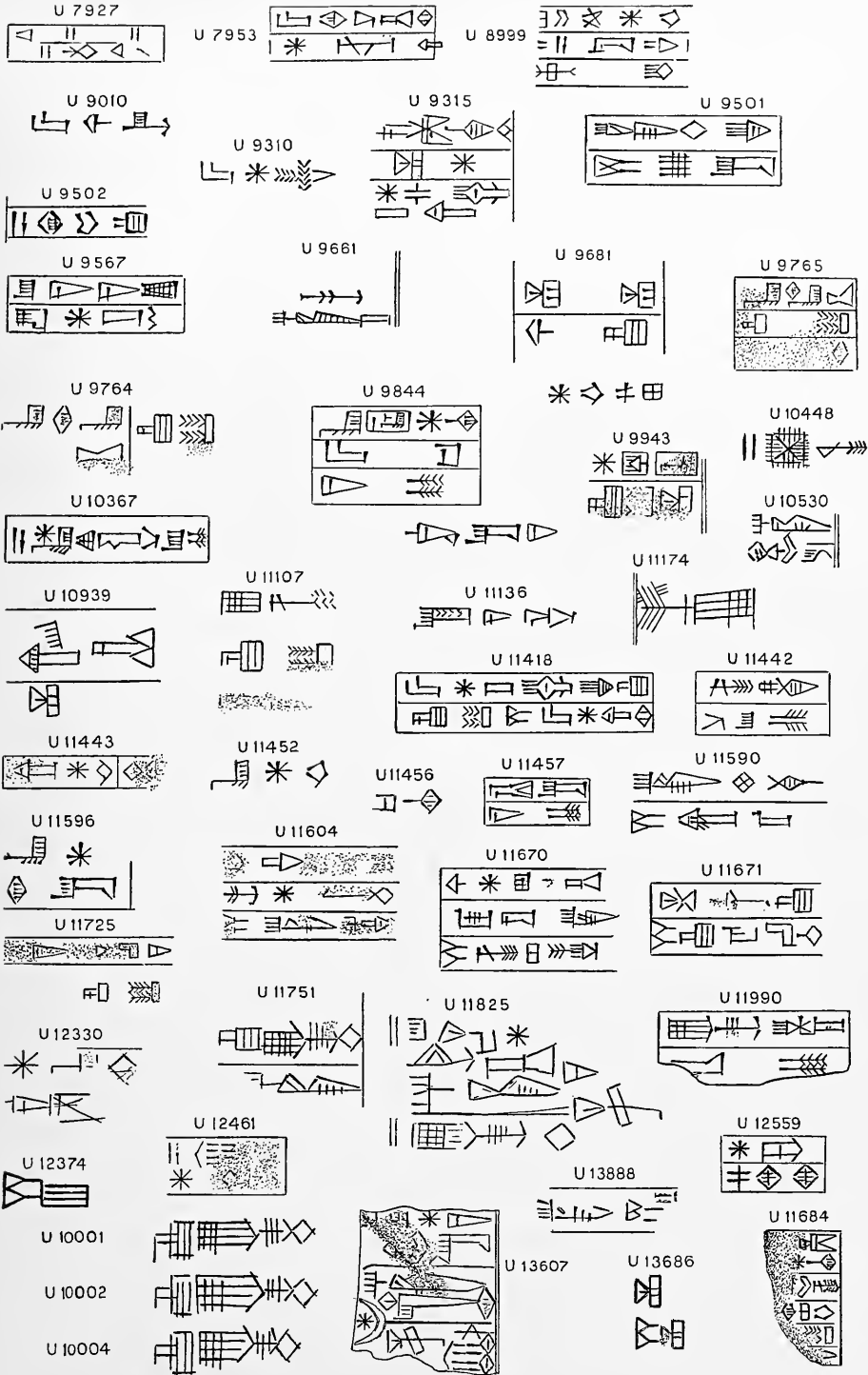

HAND COPIES OF INSCRIPTIONS FROM THE GRAVES



1. U. 11110



2. U. 12658



3. U. 12675



4. U. 11182

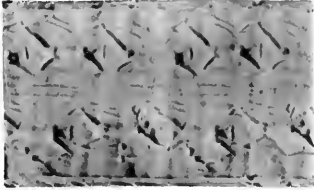

5. U. 12711

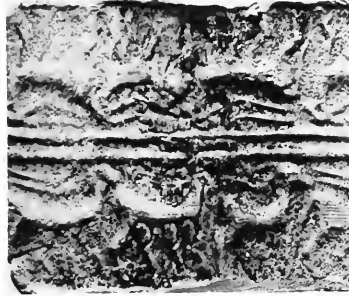

6. U. 8388



7. U. 12704 F



9. U. 11181



8. U. 8714

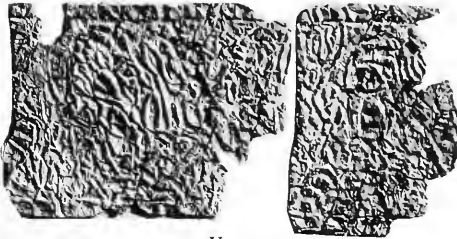

10. U. 10444

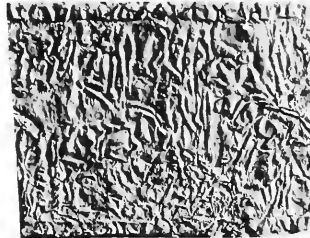

11. U. 10444 A

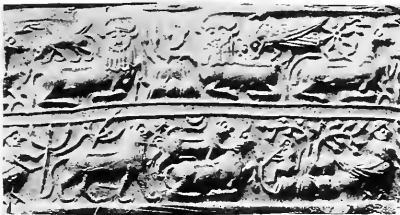

12. U. 11734

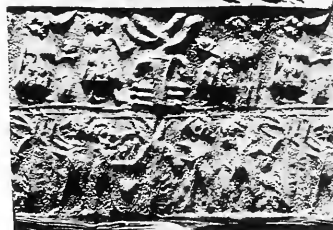

13. U. 10323.

A. SEALS DATED BY EXTERNAL EVIDENCE TO THE EARLIER
PART OF THE ROYAL CEMETERY PERIOD



14. U. 12427



15. U. 11871



16. U. 10930

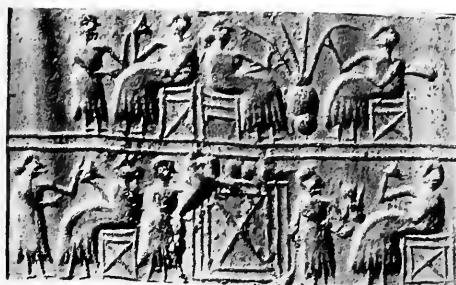

17. U. 10871



18. U. 10872

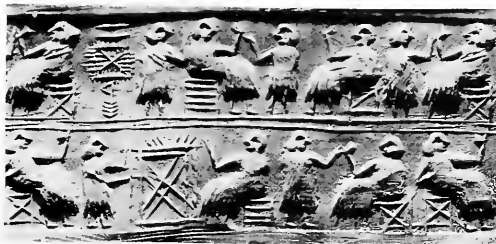

19. U. 10448 A



20. U. 14319



21. U. 11904

A. SEALS DATED BY EXTERNAL EVIDENCE TO THE EARLIER PART OF THE ROYAL CEMETERY PERIOD

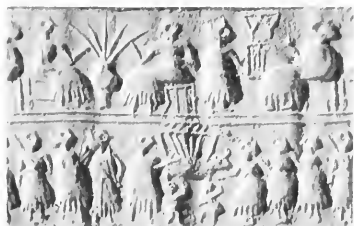

22. U. 12374

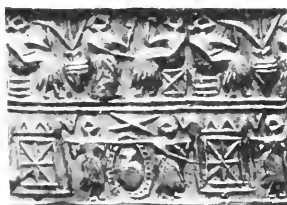

23. U. 12387



24. U. 13499



25. U. 14443

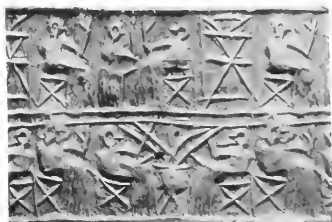

26. U. 8119



27. U. 8615



28. U. 11774



29. U. 10823

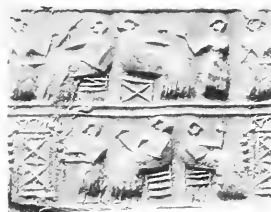

30. U. 12258



31. U. 12433



32. U. 12330



33. U. 12256

A. SEALS DATED BY EXTERNAL EVIDENCE TO THE EARLIER
PART OF THE ROYAL CEMETERY PERIOD

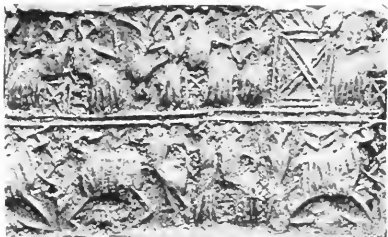

34. U. 8085

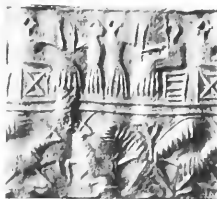

35. U. 11773

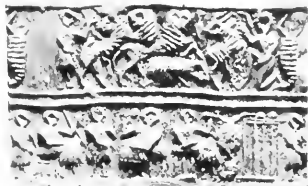

36. U. 10822



37. U. 14041



38. U. 8643

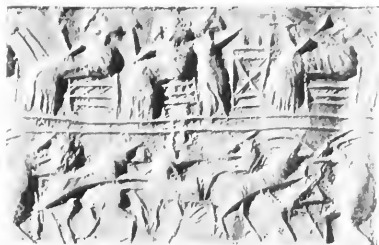

39. U. 12380

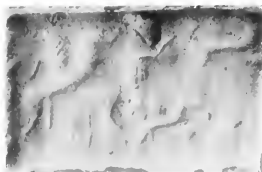

41. U. 14087

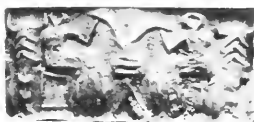

40. U. 12371

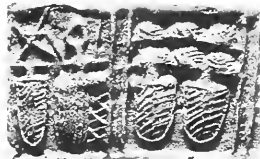

42. U. 8575



43. U. 12448



44. U. 11528



45. U. 14327



46. U. 12707 D

A. SEALS DATED BY EXTERNAL EVIDENCE TO THE EARLIER PART OF THE ROYAL CEMETERY PERIOD



47. U. 8228

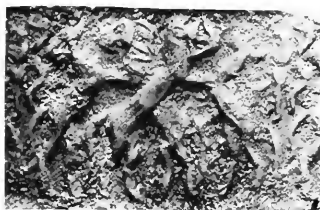

48. U. 8389



49. U. 8056

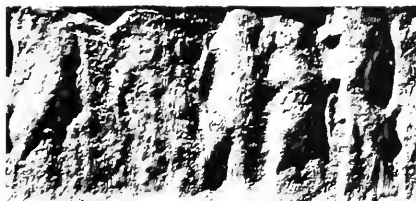

50. U. 8056 bis



51. U. 14013



52. U. 9878



53. U. 12720

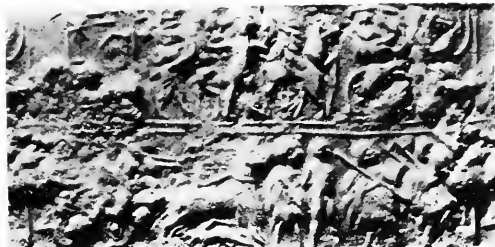

54. U. 12461

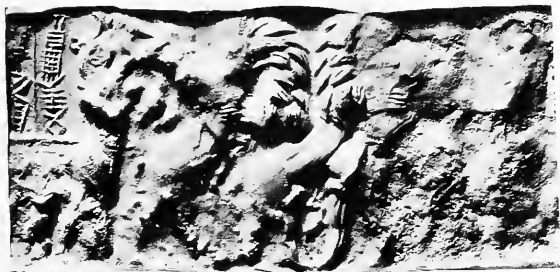

55. U. 11751

A. SEALS DATED BY EXTERNAL EVIDENCE TO THE EARLIER
PART OF THE ROYAL CEMETERY PERIOD



56. U. 12457 (see Pl. 217)



57. U. 9943



58. U. 7992



59. U. 8141



60. U. 8513



62. U. 11175 B



61. U. 11178



63. U. 10530

A. SEALS DATED BY EXTERNAL EVIDENCE TO THE EARLIER PART OF THE ROYAL CEMETERY PERIOD



64. U. 11174



65. U. 11825

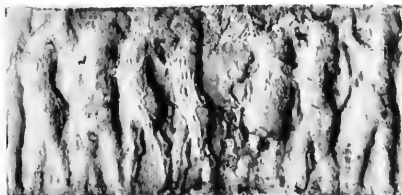

66. U. 12707 E



67. U. 12674

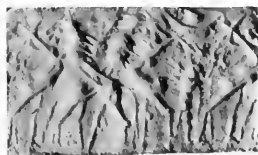

68. U. 12704 G

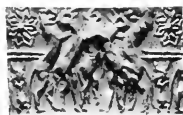

69. U. 11554

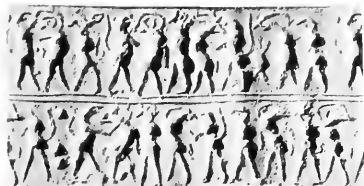

70. U. 12654



71. U. 11938



72. U. 12413



73. U. 11112

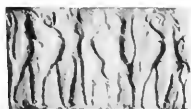

74. U. 12701 E



75. U. 10708

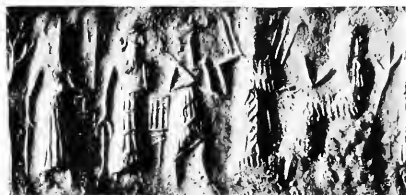

76. U. 11107

A. SEALS DATED BY EXTERNAL EVIDENCE TO THE EARLIER PART OF THE ROYAL CEMETERY PERIOD



77. U. 12087



78. U. 11899



79. U. 10987



80. U. 8662

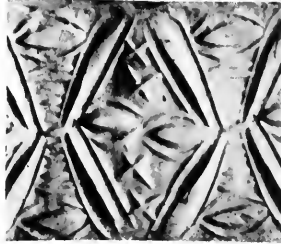

81. U. 12765

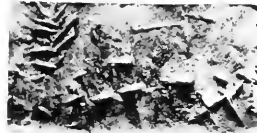

82. U. 9645



83. U. 8910



84. U. 11757



85. U. 9264



86. U. 12350



87. U. 9513



88. U. 9051



89. U. 9618



90. U. 11957



91. U. 12112



92. U. 8424



93. U. 12019

A'. SEALS ASSIGNED ON INTERNAL EVIDENCE TO THE EARLIER
PART OF THE ROYAL CEMETERY PERIOD



94. U. 11401



95. U. 14441



97. U. 11509



96. U. 15479

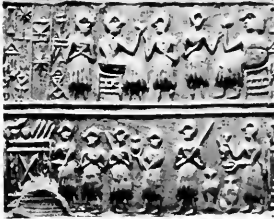

98. U. 9315

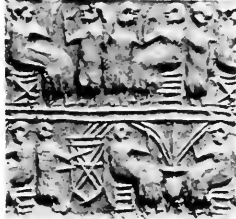

99. U. 7985



100. U. 8053



101. U. 7657



102. U. 14473 A

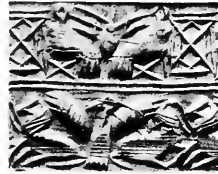

103. U. 8461

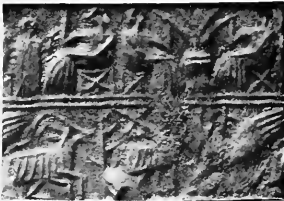

104. U. 13521



105. U. 8792



106. U. 11828



107. U. 8006



108. U. 15477

A. SEALS ASSIGNED ON INTERNAL EVIDENCE TO THE EARLIER PART OF THE ROYAL CEMETERY PERIOD



109. U. 14270



110. U. 15476



111. U. 11852

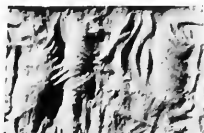

112. U. 12034



113. U. 11889



114. U. 13515



115. U. 9166



116. U. 11978

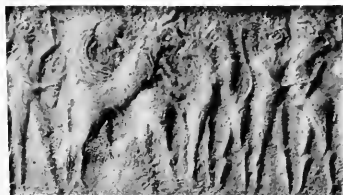

117. U. 13516



118. U. 9023



119. U. 8494

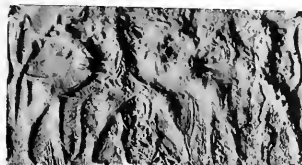

120. U. 12640

A'. SEALS ASSIGNED ON INTERNAL EVIDENCE TO THE EARLIER PART OF THE ROYAL CEMETERY PERIOD

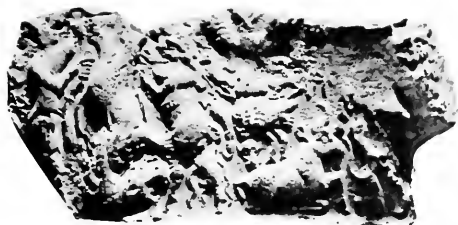

121. U. 13815



121 a. U. 13865

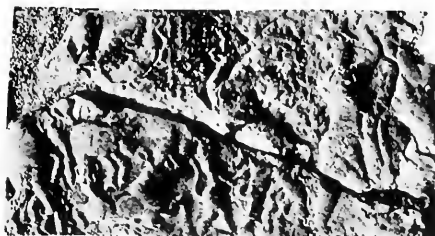

121 b. U. 13854



121 c. U. 13863



122. U. 13942



125. U. 11600

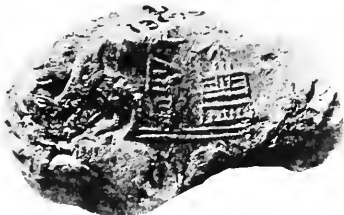

123. U. 13679



124. U. 14090

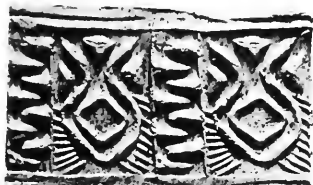

125 A. U. 8713



126. U. 8673



127. U. 11490



127 A. U. 15483



128. U. 14216

A'. SEALS ASSIGNED ON INTERNAL EVIDENCE TO THE EARLIER PART OF THE ROYAL CEMETERY PERIOD



129. U. 11488



130. U. 11973



131. U. 11868



132. U. 11566

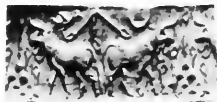

133. U. 8169



134. U. 8584

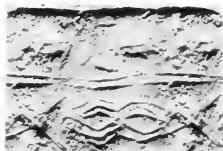

135. U. 12011

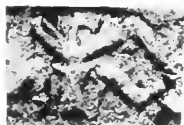

136. U. 8668



137. U. 11533



138. U. 8367

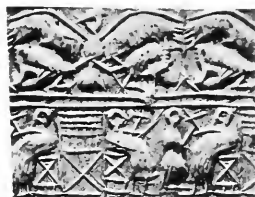

139. U. 8656



140. U. 11952



141. U. 12664



142. U. 9117

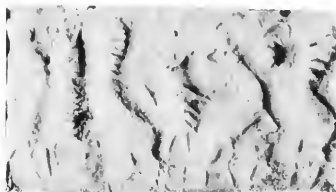

143. U. 12678

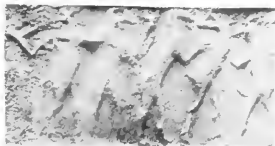

144. U. 12084



145. U. 10764

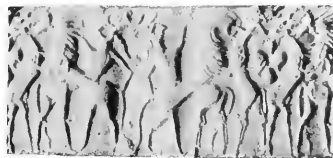

146. U. 12680

B. SEALS DATED BY EXTERNAL EVIDENCE TO THE LATER PART OF THE ROYAL CEMETERY PERIOD

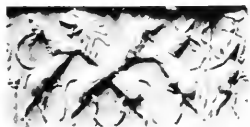

147. U. 12158

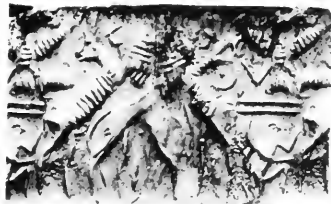

148. U. 8290



150. U. 13574



149. U. 12296

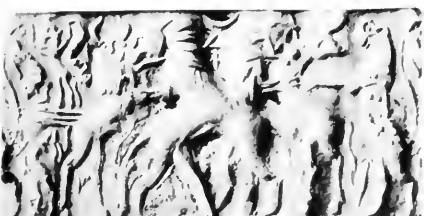

151. U. 11565



152. U. 12053



153. U. 8721



154. U. 9028



155. U. 9733



156. U. 7955



157. U. 10766 A

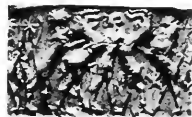

158. U. 8464



159. U. 10168



160. U. 10303



161. U. 11499



162. U. 9242

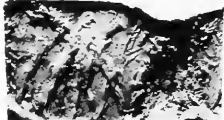

163. U. 12157



164. U. 8646



165. U. 10153



166. U. 8359

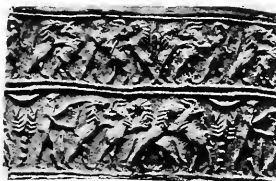

167. U. 9082

B. SEALS DATED BY EXTERNAL EVIDENCE TO THE LATER PART OF THE ROYAL CEMETERY PERIOD



168. U. 10765



169. U. 9764



170. U. 9740



171. U. 9661



172. U. 9283



173. U. 9808



174. U. 7989



175. U. 9150



176. U. 9083



177. U. 9765



178. U. 7953



179. U. 7927



180. U. 9679



181. U. 8666

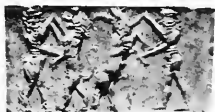

182. U. 9183



183. U. 9145



184. U. 13552

B. SEALS DATED BY EXTERNAL EVIDENCE TO THE LATER
PART OF THE ROYAL CEMETERY PERIOD



185. U. 9923



186. U. 9893



187. U. 7954



188. U. 7956



189. U. 9282



190. U. 9681

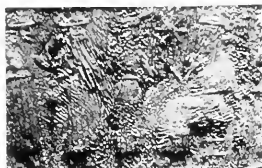

191. U. 9829



192. U. 9721



193. U. 11476



194. U. 9261

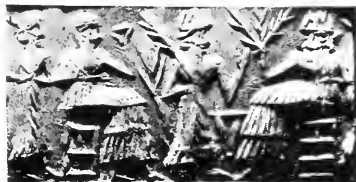

195. U. 11983



197. U. 10766 B



196. U. 11582



198. U. 9844



199. U. 11846

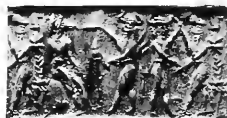

200. U. 9310



201. U. 11725

B. SEALS DATED BY EXTERNAL EVIDENCE TO THE LATER
PART OF THE ROYAL CEMETERY PERIOD



202. U. 8339



203. U. 8420



204. U. 8681



205. U. 9263



206. U. 11895

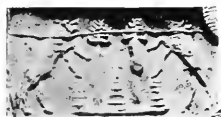

207. U. 11123



208. U. 8385



209. U. 15473



210. U. 11863

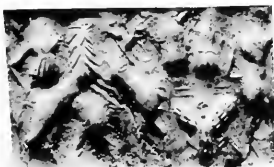

211. U. 12114



212. U. 13502



214. U. 13607



213. U. 11690



215. U. 13678, 13686 A, B



216. U. 8981

B'. SEALS ASSIGNED ON INTERNAL EVIDENCE TO THE LATER PART OF THE ROYAL CEMETERY PERIOD



217. U. 11897

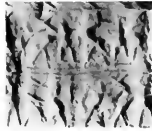

218. U. 12706



219. U. 12667

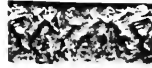

220. U. 8345

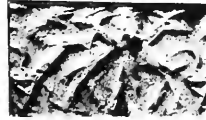

221. U. 12031



222. U. 8911



223. U. 9069



224. U. 11136

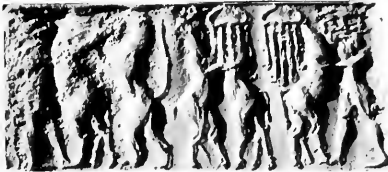

225. U. 11896



226. U. 9809

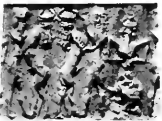

227. U. 9321

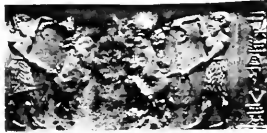

228. U. 10367

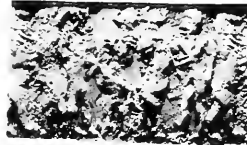

229. U. 9120

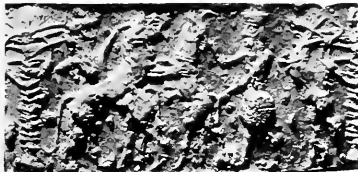

230. U. 11496



231. U. 11885

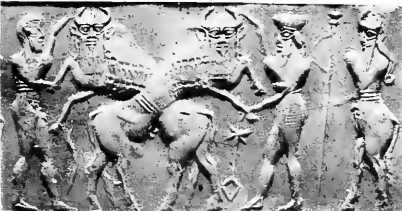

232. U. 8993



233. U. 11456

B'. SEALS ASSIGNED ON INTERNAL EVIDENCE TO THE LATER
PART OF THE ROYAL CEMETERY PERIOD



234. U. 9330



235. U. 8416

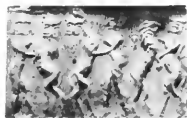

239. U. 12079



236. U. 9502



237. U. 11961

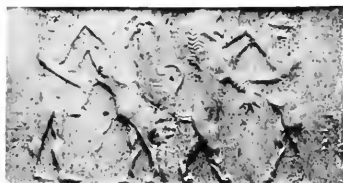

238. U. 9551



240. U. 7641



241. U. 11990



242. U. 10364



243. U. 11745

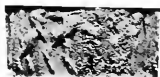

244. U. 9908



245. U. 9526

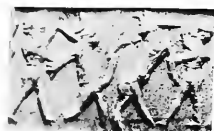

246. U. 8991

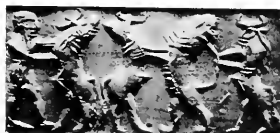

247. U. 10302



248. U. 11150



249. U. 9298



250. U. 9614



251. U. 12086

B'. SEALS ASSIGNED ON INTERNAL EVIDENCE TO THE
LATER PART OF THE ROYAL CEMETERY PERIOD



252. U. 9056



253. U. 8065

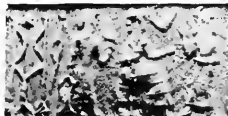

254. U. 9858



255. U. 8793



256. U. 8012



257. U. 12666



258. U. 11515



259. U. 11462



260. U. 11405



261. U. 11473



263. U. 9264



264. U. 9186



265. U. 12017

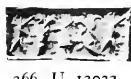

266. U. 12032



262. U. 11438



267. U. 9266



269. U. 8342



268. U. 9158



270. U. 9851



273. U. 9326

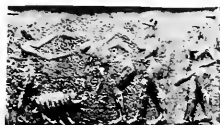

272. U. 9620

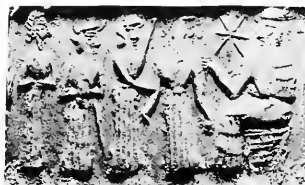

271. U. 9165 B



274. U. 9262



275. U. 11402

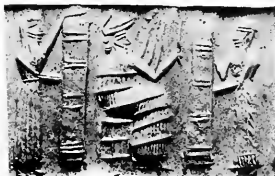

277. U. 9100



278. U. 12029



276. U. 12639

B'. SEALS ASSIGNED ON INTERNAL EVIDENCE TO THE LATER
PART OF THE ROYAL CEMETERY PERIOD



279. U. 10192



279 A. U. 12701 F



280. U. 12705

B'. SEALS ASSIGNED ON INTERNAL EVIDENCE TO THE LATER PART OF THE ROYAL CEMETERY PERIOD



281. U. 15302



282. U. 15308



283. U. 15318



284. U. 17812



285. U. 17649



286. U. 17656

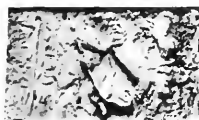

287. U. 17811

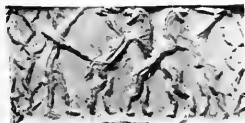

288. U. 17650

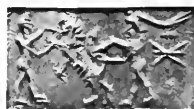

289. U. 15303



290. U. 12470



291. U. 10757



292. U. 12471



293. U. 17815



294. U. 17912



295. U. 17904



296. U. 15307



296 A. U. 17806



297. U. 15309

SEALS DATED BY EXTERNAL EVIDENCE TO THE SECOND DYNASTY OF UR

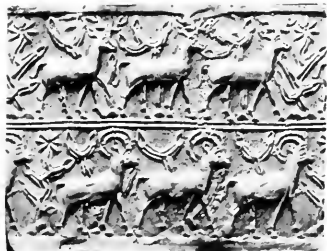

298. U. 9751



299. U. 9587



300. U. 12679



304. U. 12040



302. U. 9027

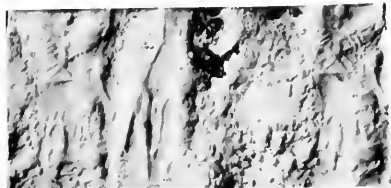

301. U. 11715



303. U. 11581



305. U. 11448

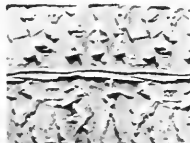

306. U. 8916

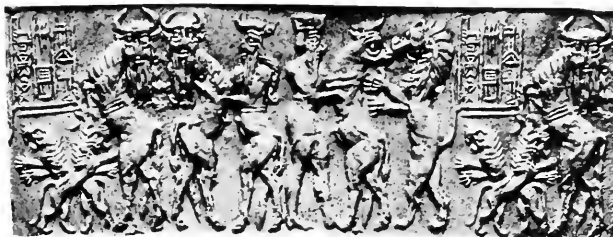

307. U. 9178



308. U. 8988



309. U. 11684

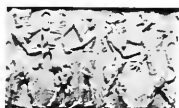

310. U. 9693



311. U. 11590



312. U. 9291



313. U. 9813



314. U. 9717



315. U. 11418



316. U. 11843

c. SEALS DATED BY EXTERNAL EVIDENCE TO THE SARGONID PERIOD

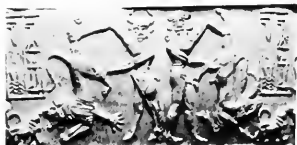

317. U. 11457



318. U. 9567

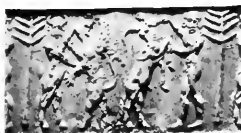

319. U. 8926

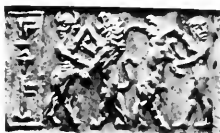

320. U. 9010



321. U. 9652



322. U. 8041



323. U. 11492



325. U. 11483

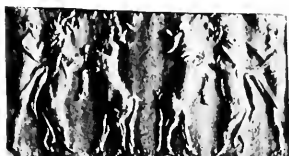

326. U. 10355



324. U. 7923



327. U. 9634



328. U. 9064



329. U. 11598



330. U. 11591

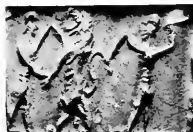

331. U. 11410



332. U. 9642



333. U. 11580



334. U. 11148

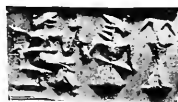

335. U. 11143



336. U. 8897

c. SEALS DATED BY EXTERNAL EVIDENCE TO THE SARGONID PERIOD

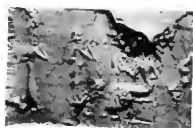

337. U. 9710



338. U. 11452

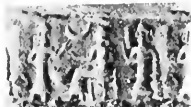

339. U. 11458



341. U. 11464



340. U. 8017



342. U. 9749



343. U. 9586



344. U. 11449

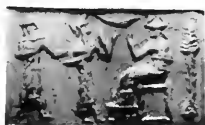

345. U. 11447



346. U. 10796



348. U. 9578

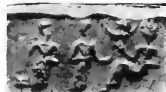

349. U. 11426

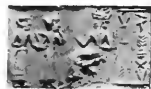

350. U. 11442



347. U. 11592



351. U. 11987



353. U. 8093



352. U. 11420

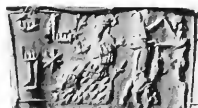

354. U. 11596



355. U. 10397



356. U. 9060



357. U. 9694



358. U. 12004



359. U. 8971



360. U. 11709



361. U. 10188

c. SEALS DATED BY EXTERNAL EVIDENCE TO THE SARGONID PERIOD

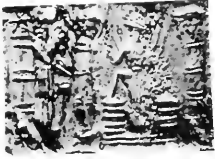

362. U. 9290



363. U. 8747

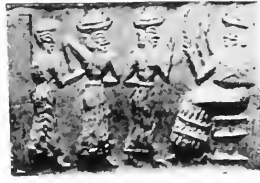

365. U. 9292

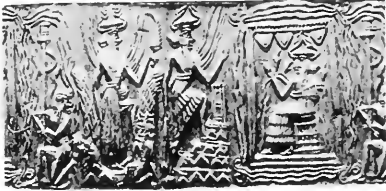

364. U. 9750



366. U. 8699

c. SEALS DATED BY EXTERNAL EVIDENCE TO THE SARGONID PERIOD



367. U. 11958

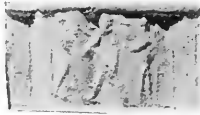

368. U. 8476



369. U. 7957

c'. SEALS ASSIGNED ON INTERNAL EVIDENCE TO THE SARGONID PERIOD



370. U. 8685



371. U. 9265



372. U. 9552



373. U. 9024

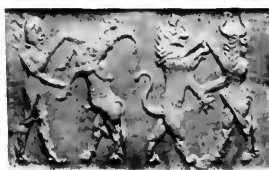

374. U. 7656

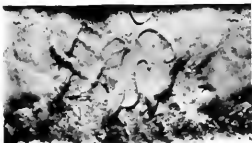

375. U. 11404



376. U. 8417

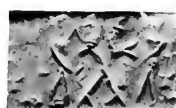

377. U. 9527

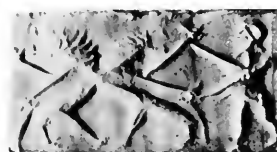

378. U. 12681



379. U. 9501



380. U. 11981



381. U. 11604



382. U. 9583



383. U. 12331



384. U. 9529

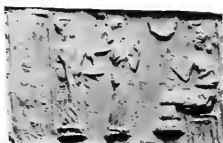

385. U. 11403



386. U. 11671



387. U. 11670



388. U. 12030



389. U. 11959



390. U. 8800



391. U. 12033



392. U. 12023

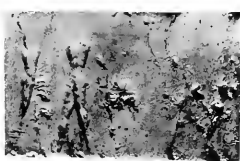

393. U. 11507



394. U. 9026

c'. SEALS ASSIGNED ON INTERNAL EVIDENCE TO THE SARGONID PERIOD

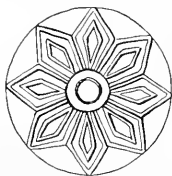
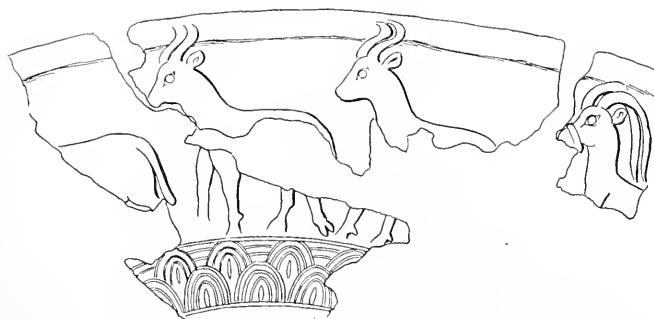

DESIGN ON SILVER BOWL

U. 11794 PG/1130
 v. Catalogue and Pl. 167

Scale $\frac{1}{3}$



DESIGN EMBOSSED ON GOLD-LEAF

U. 12457 PG/1236
 v. p. 113 and Pl. 197

Scale $\frac{1}{3}$



PG/760

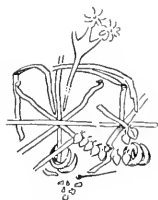

PG/789 C



PG/789 F

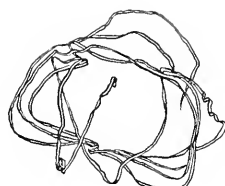

PG/337

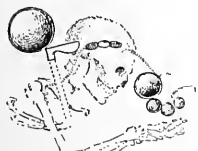

PG/429

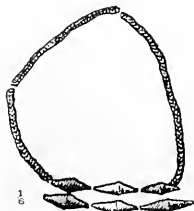

PG/734



PG/495



PG/703



PG/789

a

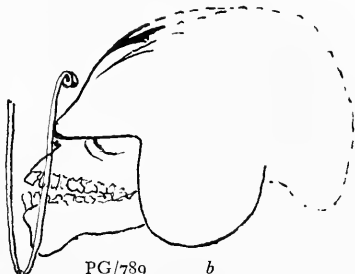

PG/789

b

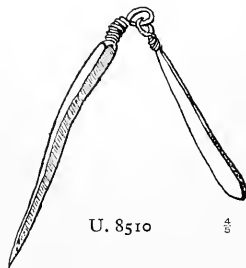

U. 8510

6/4

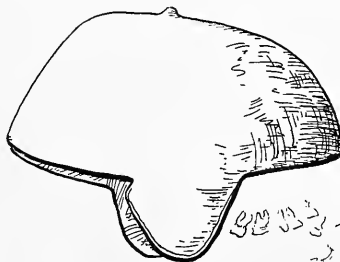

PG/789

c



U. 8550



U. 17927

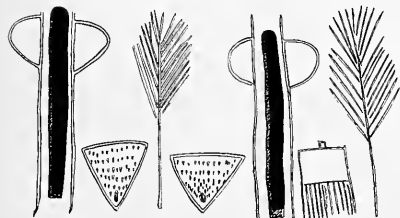

U. 13709



U. 8550

6/5

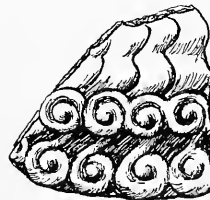

U. 8798

6/5

HEAD-DRESSES AS WORN, HELMETS, VARIA



Type 1



Type 2



U. 10758



U. 8928



U. 9325
Type 4



U. 10375
Type 5



HAIR-RING



PG/635
HAIR RIBBON



Type 6
EAR-RINGS



U. 12467
Type 7



U. 10316
Type 8



U. 11584
Type 9



U. 17913
Type 10



FRONTLETS Type 1



Type 2



Type 3



U. 9781

Type 5



U. 10558
Type 4



U. 8653
PG/581



U. 8397



U. 8072



U. 8073

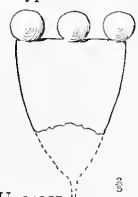

U. 14257



COMB U. 11595



U. 9610



PG/780



U. 8904



U. 11968



U. 12375

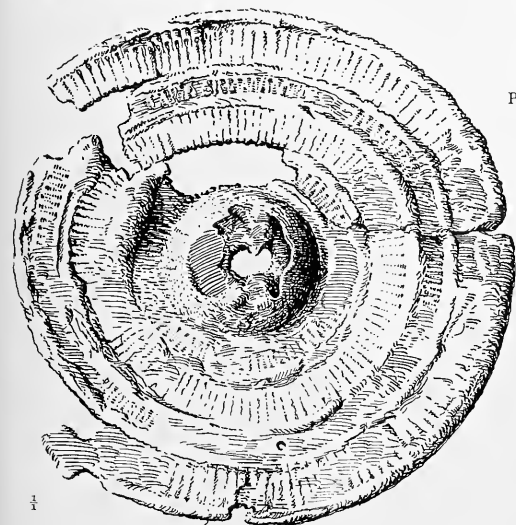

U. 9365



U. 8374

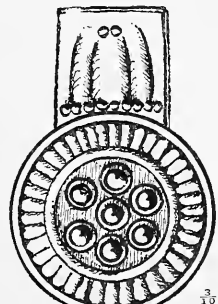

U. 8007

EAR-RINGS, HAIR-RING, FRONTLETS,
AMULETS, COMB, BROOCHES (?)



U. 14259



U. 8565



U. 8527



U. 12459



U. 9281



U. 10975

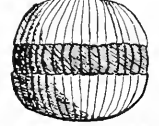

U. 8931



U. 9786

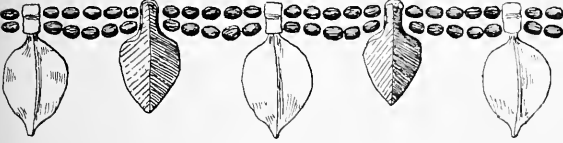

U. 9656

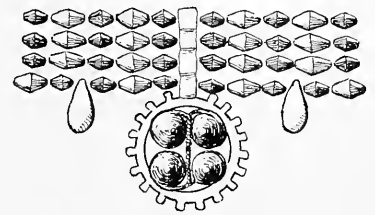

U. 8568

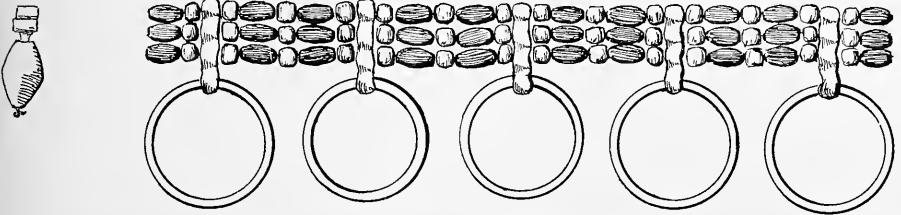

U. 8528

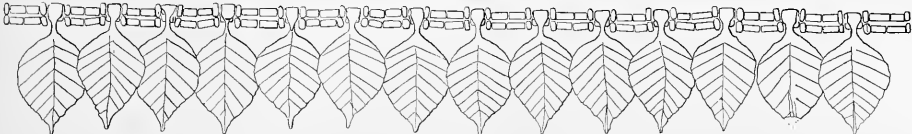

U. 12380

Scale 1/2

BEADS AND PENDANTS

v. Ch. xviii



U. 8454 $\frac{1}{2}$
PG/254



U. 8454 $\frac{1}{2}$

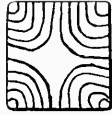

U. 8454 $\frac{1}{2}$

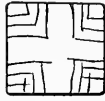

U. 8509 $\frac{1}{2}$



U. 8509 $\frac{2}{3}$

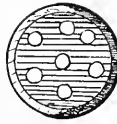

U. 8509 $\frac{1}{2}$



U. 8454 $\frac{1}{2}$



U. 12431

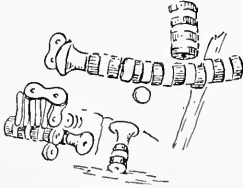

U. 8935 PG/449
Sistrum (?)
v. p. 261

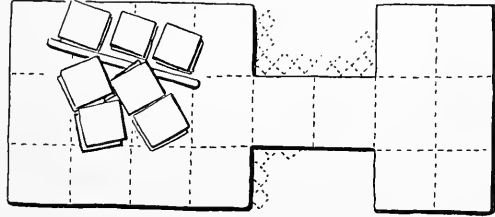

U. 10557 PG/789 $\frac{1}{3}$
Gaming pieces inside the box
v. p. 278



U. 8251



U. 8213

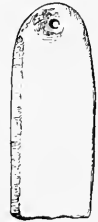

U. 8188

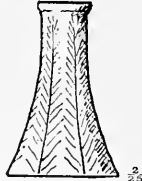

U. 9914



U. 8223



U. 71

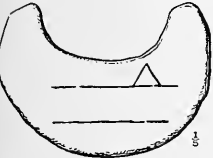

U. 8323

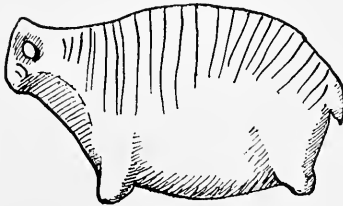

U. 17657



U. 13555



U. 8578



U. 8323

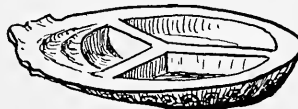

U. 11841

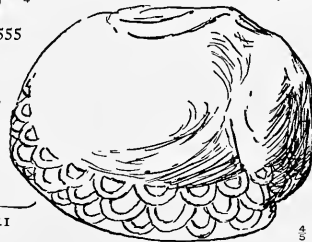

U. 11841

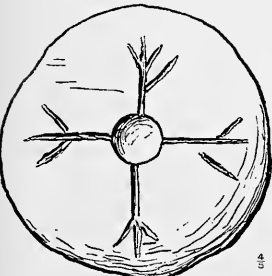

U. 8696

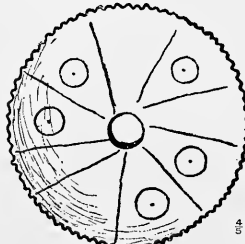

U. 8301

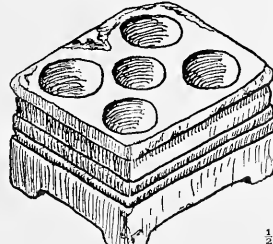

U. 8731

VARIA

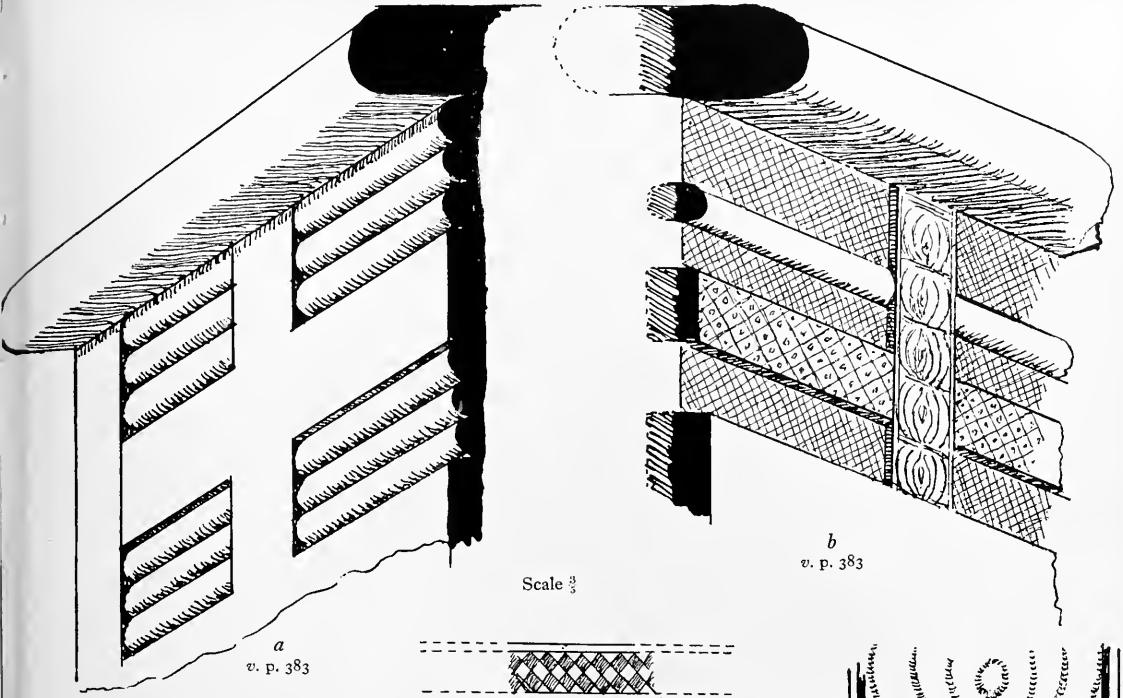

a
v. p. 383

b
v. p. 383

Scale $\frac{3}{4}$

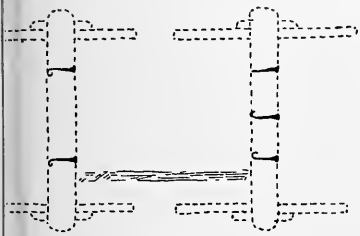

PG/789

$\frac{1}{24}$

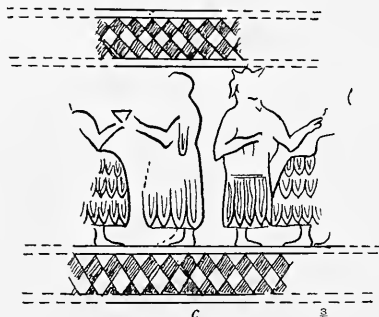

c
v. p. 383

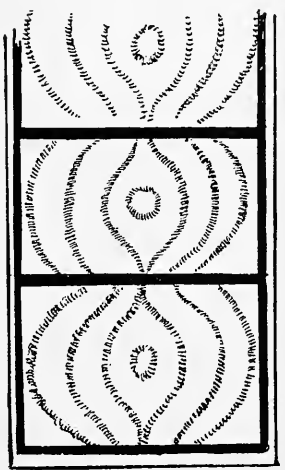

d

v. p. 383

$\frac{1}{2}$



PG/677

$\frac{4}{5}$



PG/730

$\frac{4}{5}$

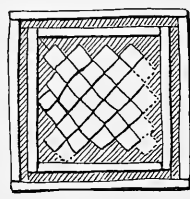

PG/556

U. 9214

$\frac{4}{5}$



PG/389

$\frac{1}{60}$

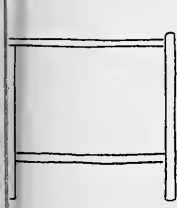

PG/38r

$\frac{2}{5}$

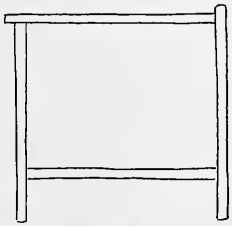

PG/789

$\frac{4}{5}$

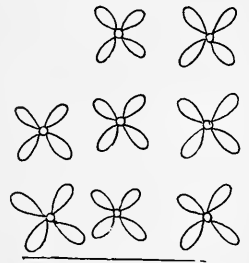

PG/87r

$\frac{4}{5}$

WOODWORK

v. Chapter xx

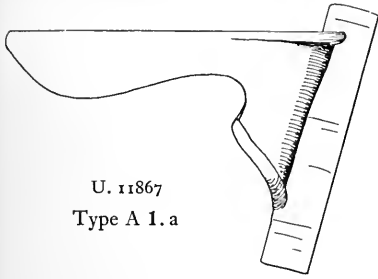

U. 11867
Type A 1. a

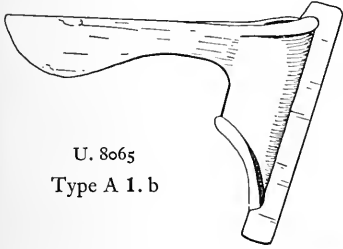

U. 8065
Type A 1. b

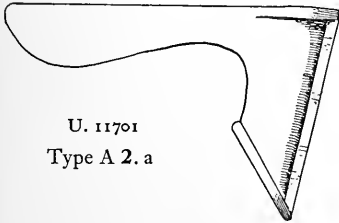

U. 11701
Type A 2. a

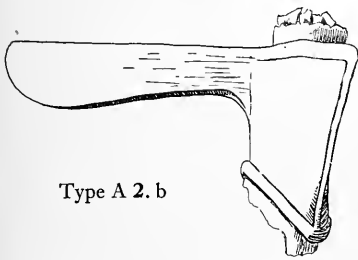

Type A 2. b

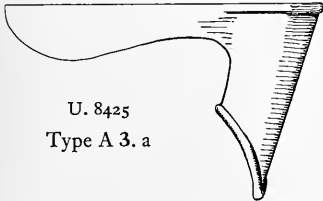

U. 8425
Type A 3. a

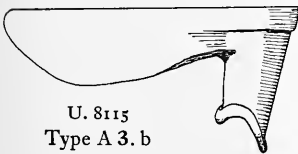

U. 8115
Type A 3. b

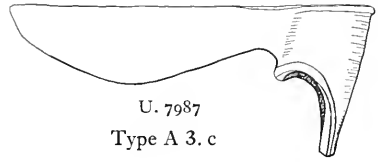

U. 7987
Type A 3. c

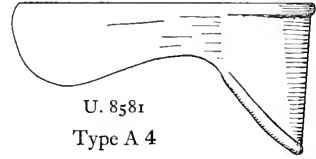

U. 8581
Type A 4

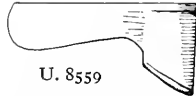

U. 8559
Type A 5. a

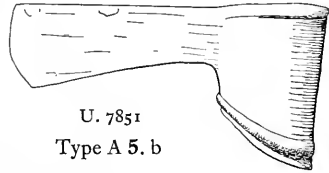

U. 7851
Type A 5. b



U. 11932
Type A 6



U. 12478
Type A 8

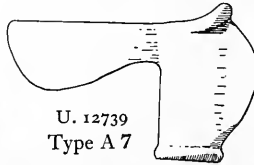

U. 12739
Type A 7



U. 12483
Type A 9

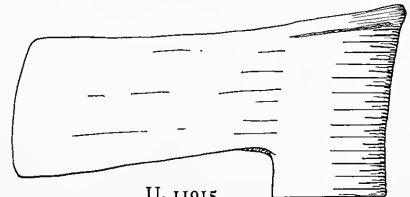

U. 11915
Type A 10

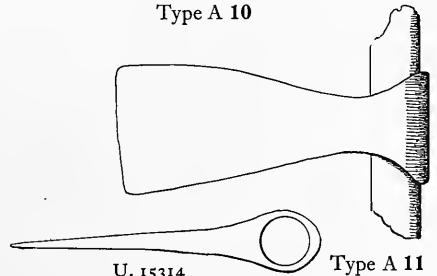

U. 15314

Type A 11

Scale $\frac{3}{8}$

TYPES OF CAST BRONZE AXES

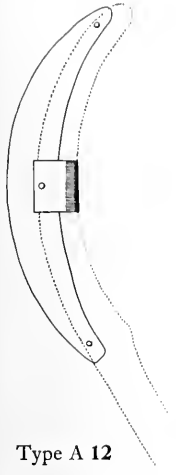

Type A 12

U. 10435

Type A 15

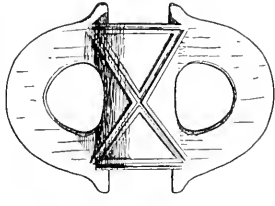

U. 10018



U. 8246

Type A 16

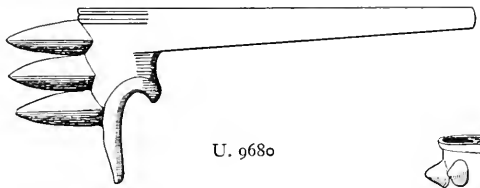

U. 9680

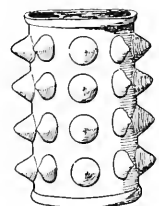

U. 9137

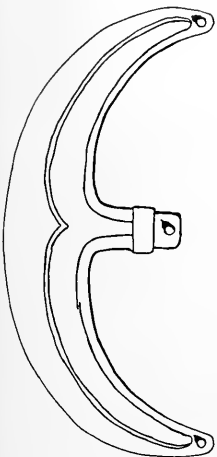

Type A 13

U. 11754

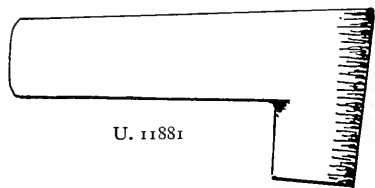

U. 11881

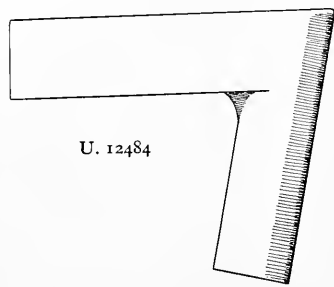

U. 12484

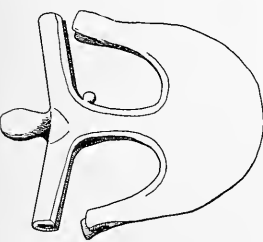

Type A 14

U. 9687

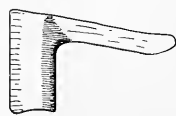

U. 10307

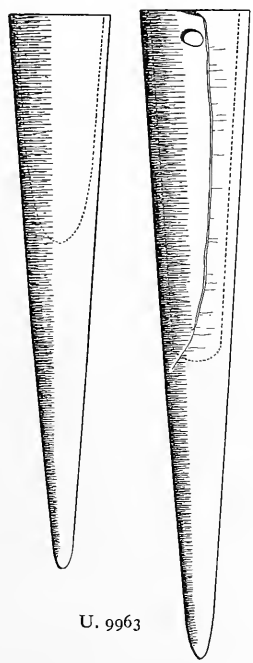

U. 9963

Scale cm

UNUSUAL TYPES OF AXES, ETC.



Type S. 1 U. 9331

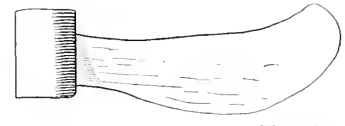

U. 9194 Type S. 9



Type S. 2 U. 8034

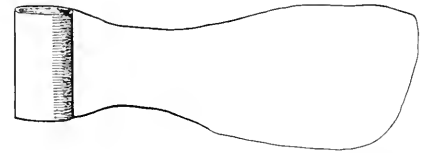

U. 17813 Type S. 10



Type S. 3 U. 8782

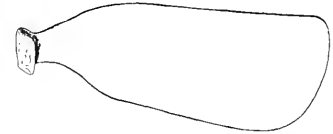

U. 7872 Type S. 11



Type S. 4 U. 9009

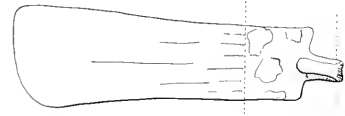

U. 8751 Type S. 12



Type S. 5 U. 8381



U. 8789 Type S. 13



Type S. 6 U. 9258



U. 7874 Type S. 14

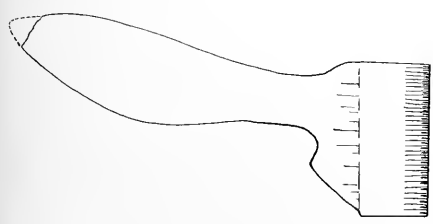

Type S. 7 U. 12625

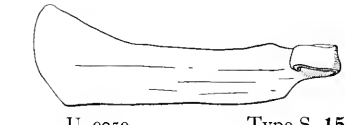

U. 9059 Type S. 15



Type S. 8 U. 7871



U. 8995 Type S. 16

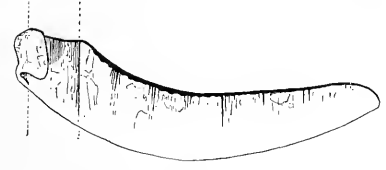

U. 6457 Type S. 17

TYPES OF HAMMERED COPPER AXES

Scale $\frac{2}{3}$

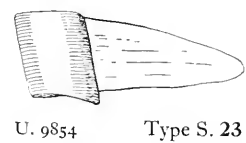
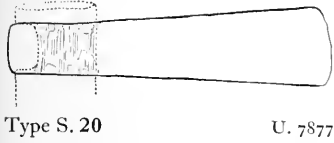
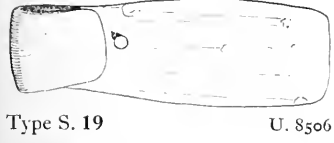
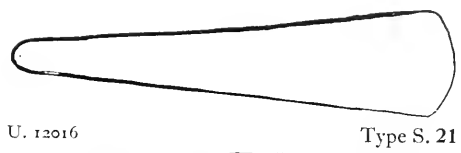

TYPES OF HAMMERED COPPER AXES

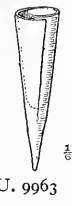
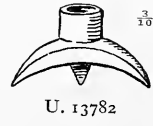
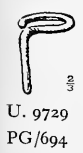
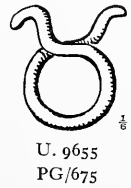
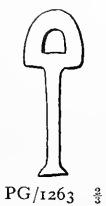
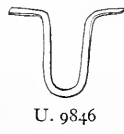
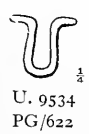
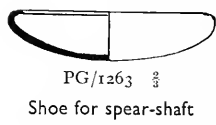
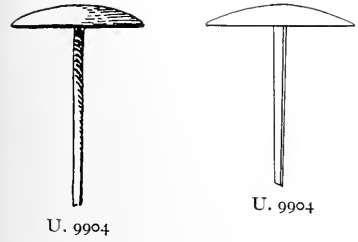
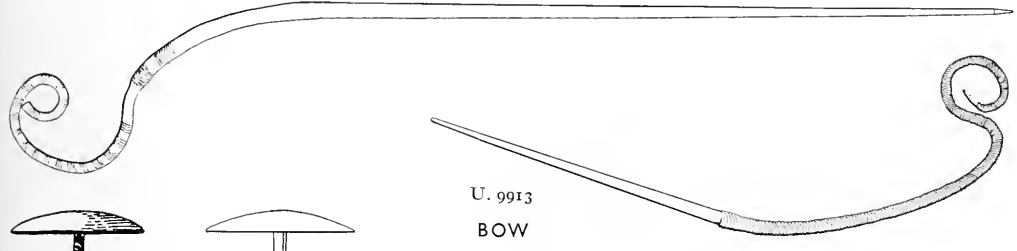

METAL HOLDFASTS, ETC.

Scale where not otherwise stated $\frac{2}{5}$

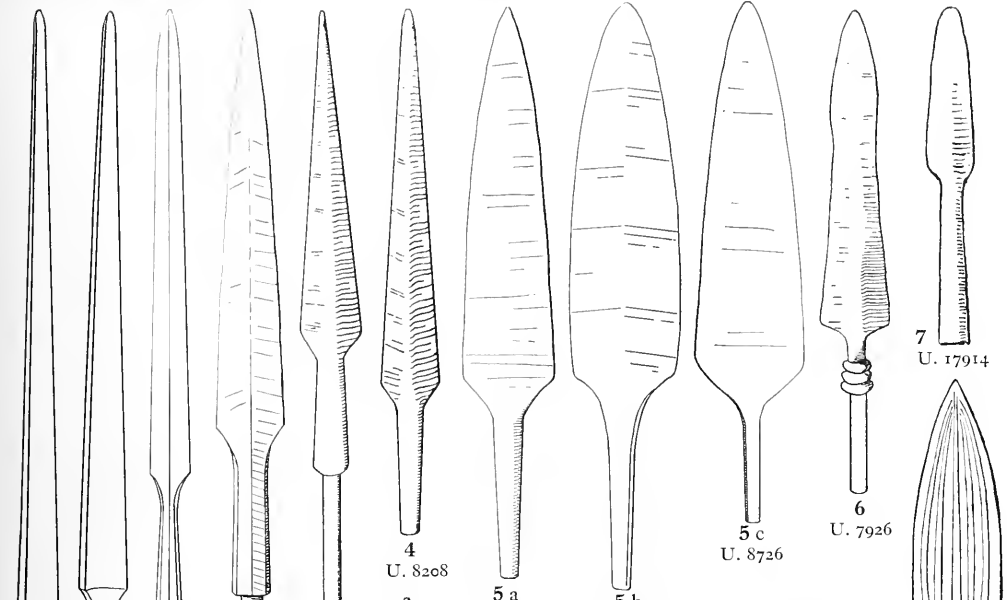

1 a U. 7925
 1 b U. 7930
 2 a U. 9122
 2 b U. 8566
 3 U. 8139
 4 U. 8268
 5 a U. 9141
 5 b U. 14295
 5 c U. 8726
 6 U. 7926
 7 U. 17914
 8 U. 10023

SPEARS

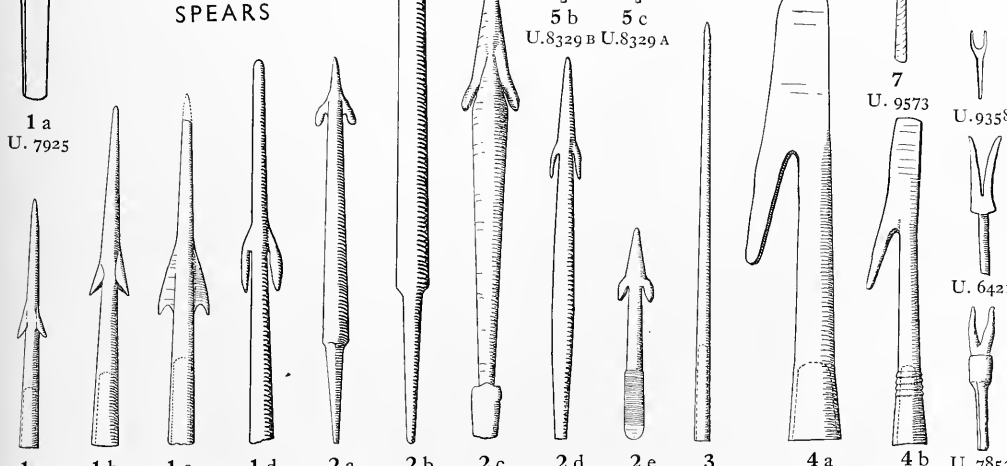

1 a U. 9342
 1 b U. 8586
 1 c U. 8236
 1 d U. 17043
 2 a U. 17616
 2 b U. 17619
 2 c U. 17445
 2 d U. 12679
 2 e U. 9338
 3 U. 11704
 4 a U. 11704
 4 b U. 9336
 5 a U. 8609
 5 b U. 8329 B
 5 c U. 8329 A
 6 a U. 7526
 6 b U. 6464
 7 U. 9573
 8 U. 9572

ARROWS

STRING NOTCHES

Scale 3/5



1
U. 17916



2
U. 12479

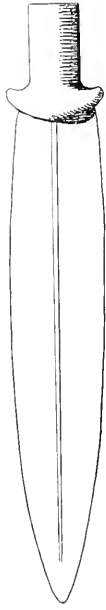

3
U. 14222

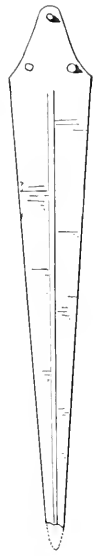

4
U. 8140



5 a
U. 8108



5 b



U. 9197



6
U. 9036



7 a
U. 8651

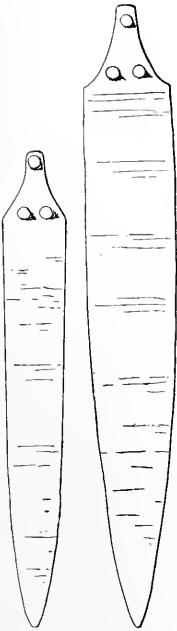

7 c
U. 8232



7 d
U. 9117

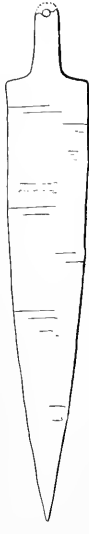

7 e
U. 7988



7 f
U. 12679



7
U. 9121



8 a
U. 11474



8 b



9 b
U. 11495



7 b
U. 7850



9 a

TYPES OF KNIVES AND DAGGERS

Scale $\frac{1}{2}$
in



Type 3
U. 8594 SAW



Type 2 U. 10476



Type 1 a

U. 8896



Type 1 b

U. 9189



Type 1 c

U. 8984

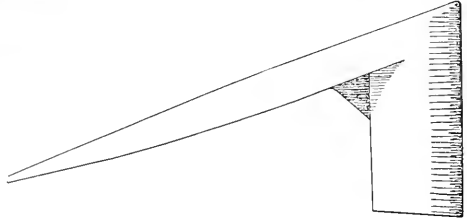

U. 12232

Type 1

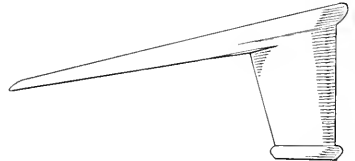

U. 9887

Type 2

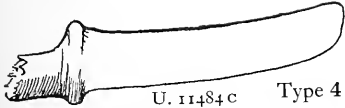

U. 11484 c

Type 4

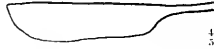

U. 15633

Type 5

TOOLS



2 a

U. 8578



2 b

U. 8106



3

U. 9072



1 a

U. 8595



1 b

U. 9130



1 c

U. 8696



1 d

U. 8677



4 a

U. 10431



4 b

U. 9131



U. 8783



U. 8307

CHISELS

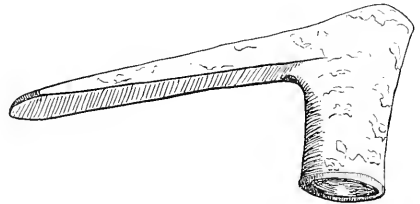

U. 7861

Type 3



U. 6927

Type 4

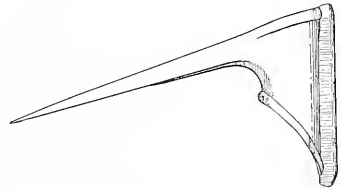

U. 9339

Type 5

ADZES

Scale 1/2 cm

U. 17926

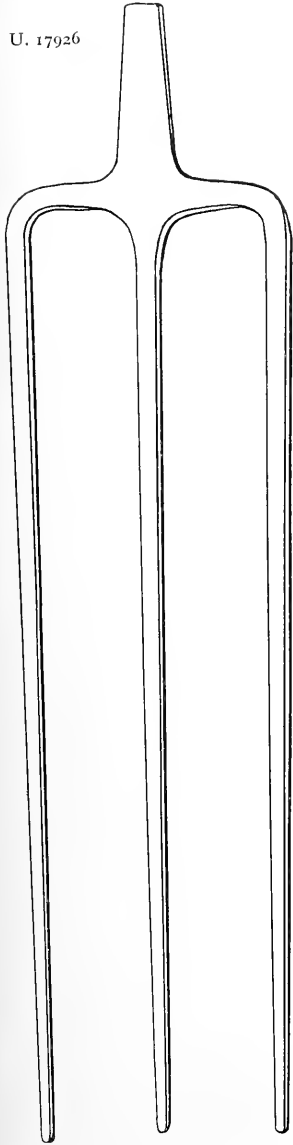

U. 9004

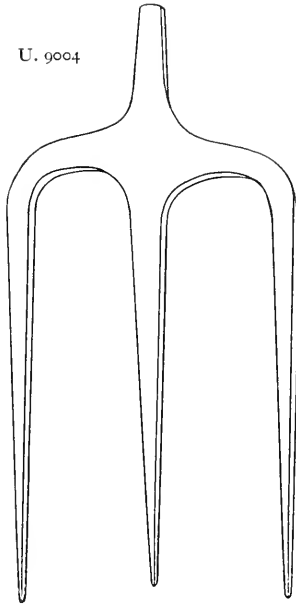

U. 15313

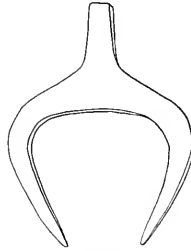
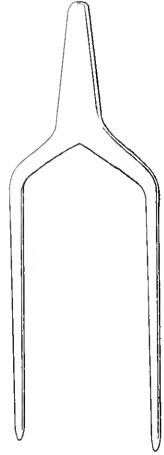

U. 9005



U. 8672



U. 8967

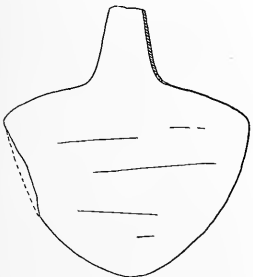

U. 12740

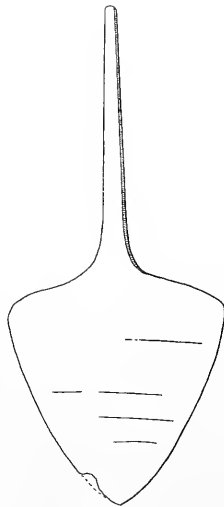

U. 11494

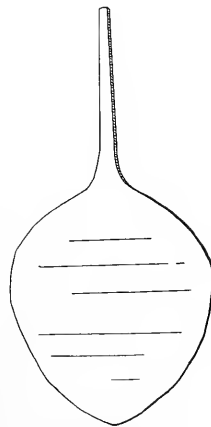

U. 12697

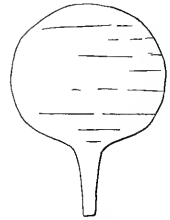

U. 11453

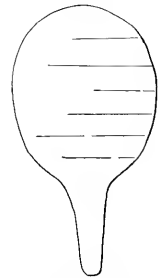

U. 11484

TOOLS, ETC.

Scale $\frac{2}{5}$

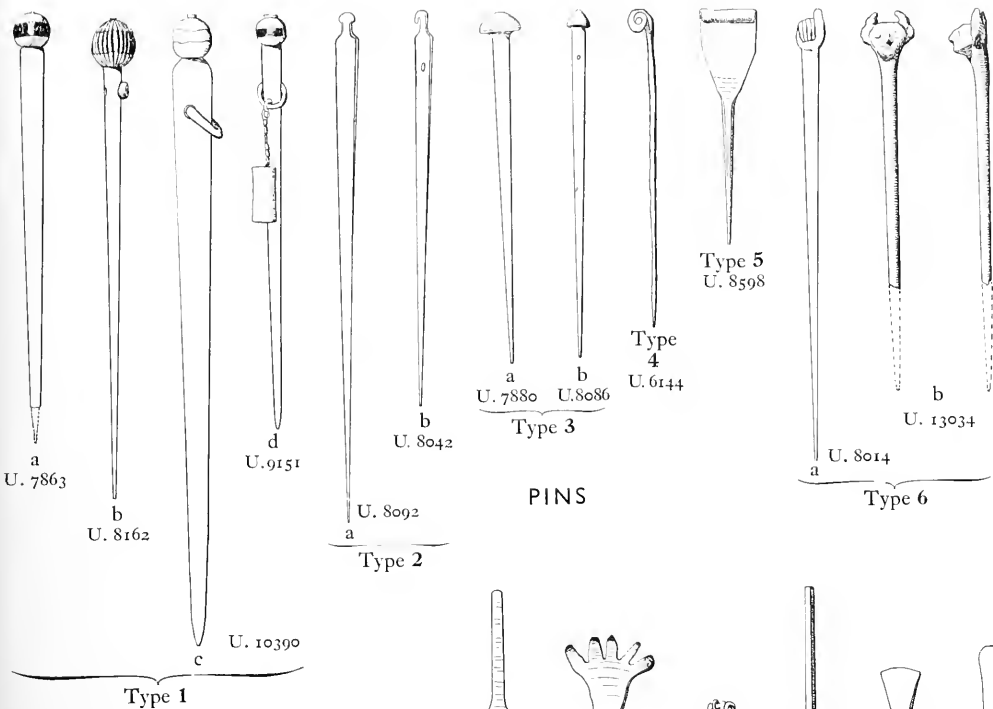

PINS

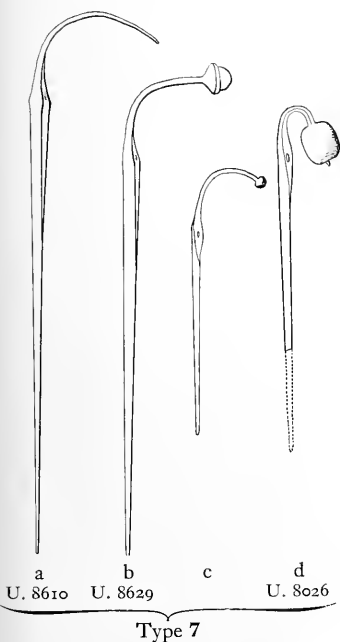

PINS

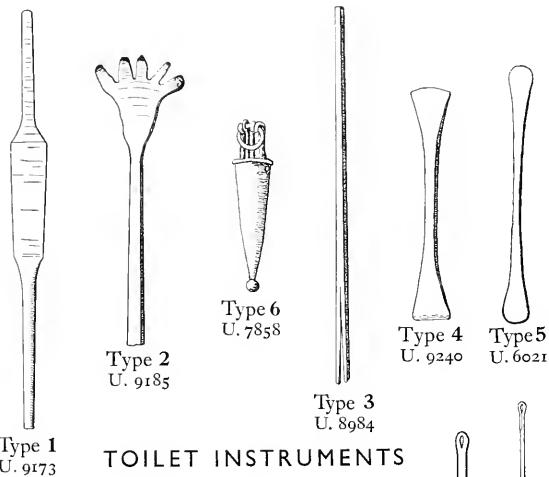

TOILET INSTRUMENTS

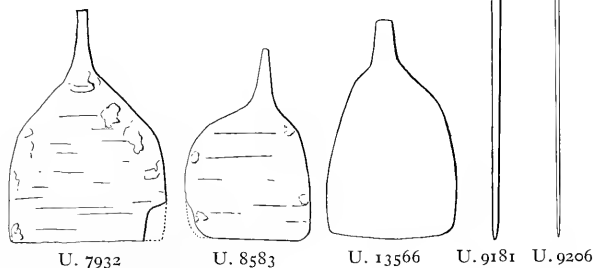

RAZORS

NEEDLES

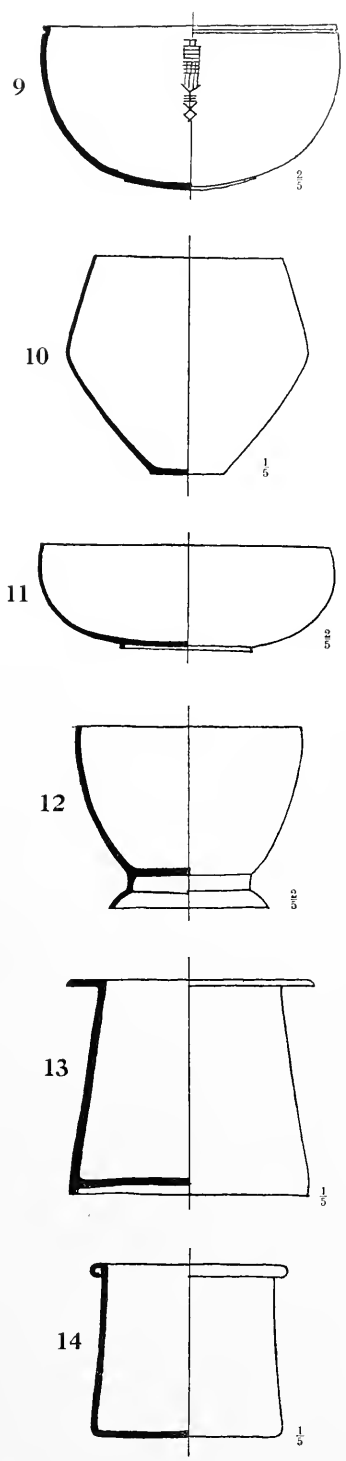
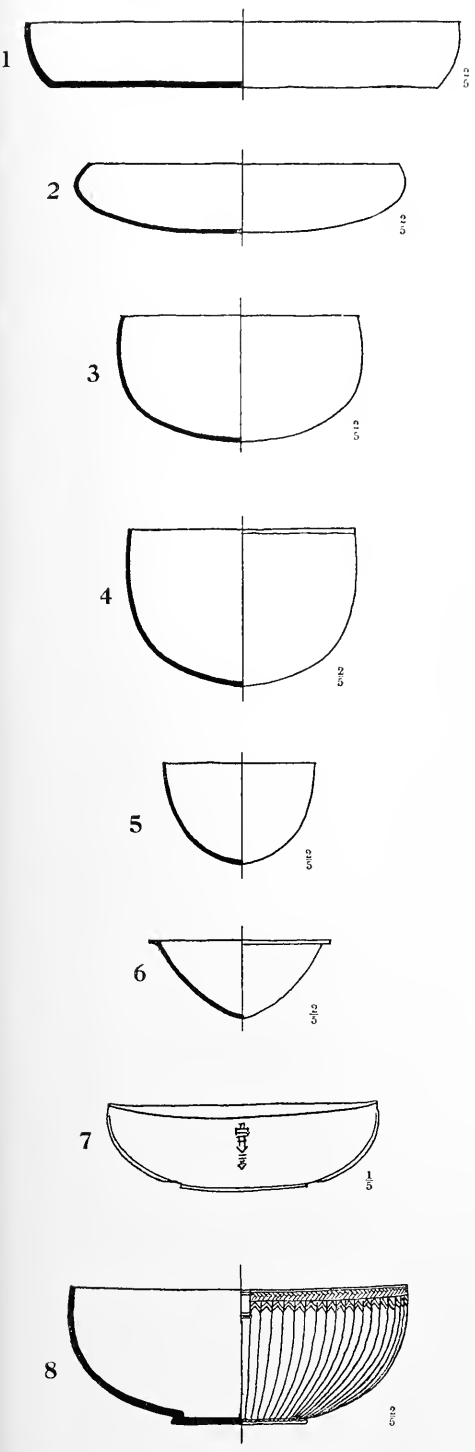

TYPES OF METAL VESSELS

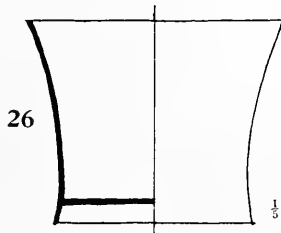
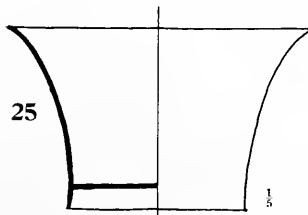
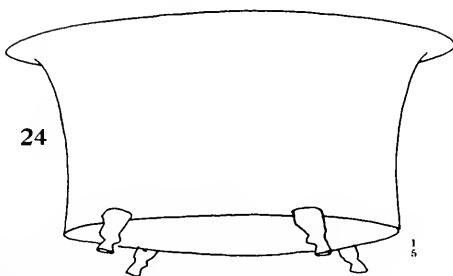
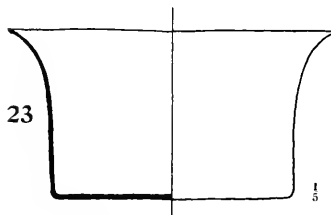
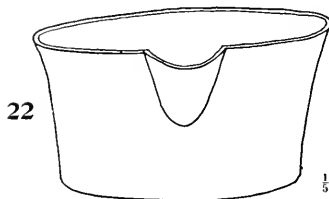
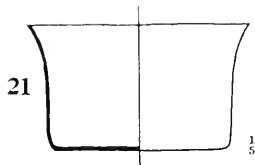
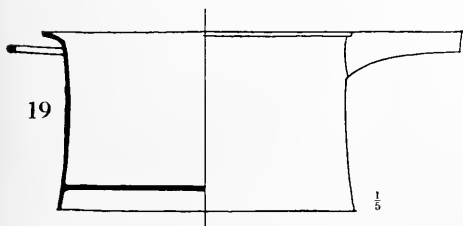
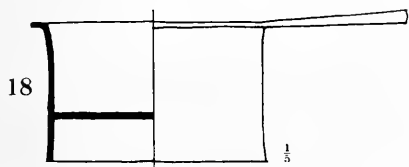
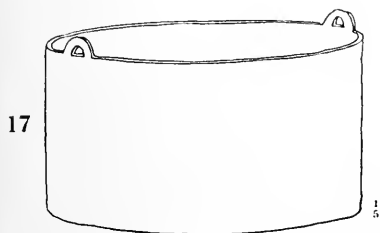
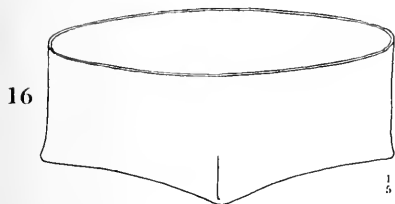
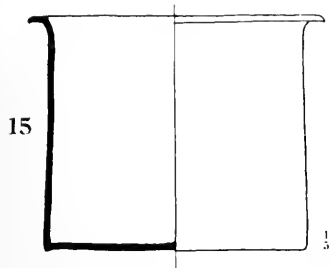

TYPES OF METAL VESSELS

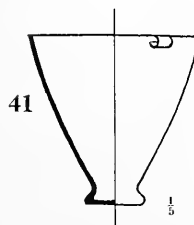
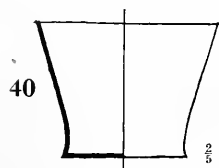
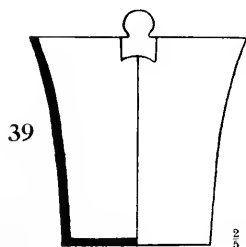
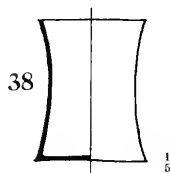
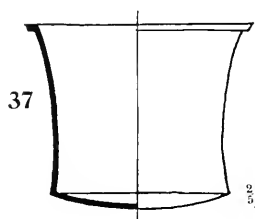
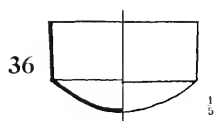
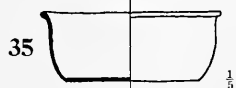
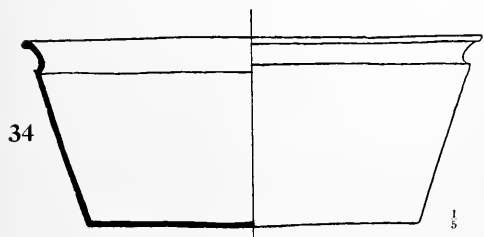
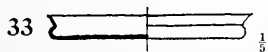
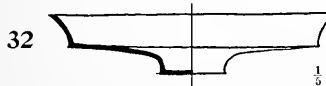
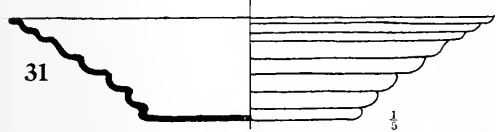
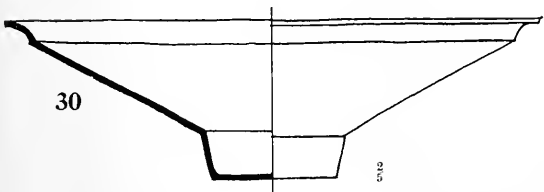
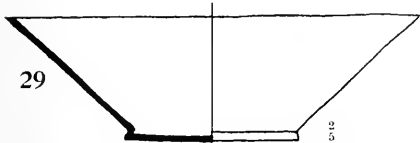
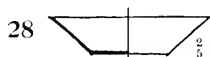
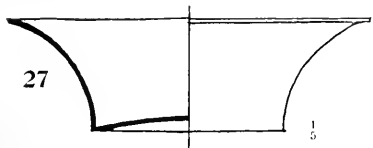

TYPES OF METAL VESSELS

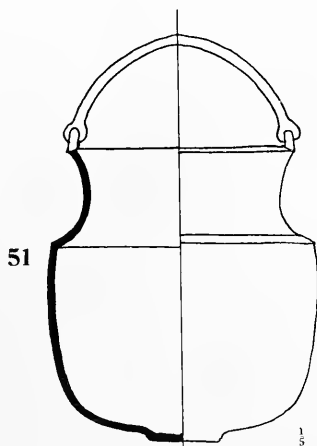
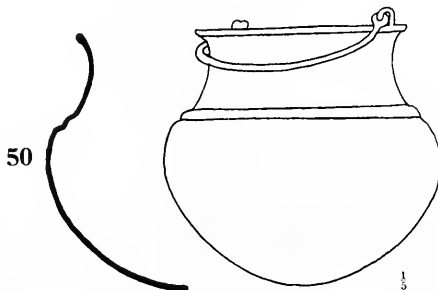
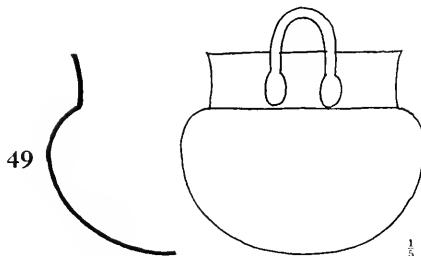
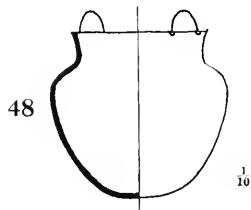
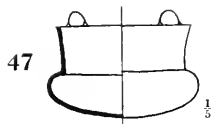
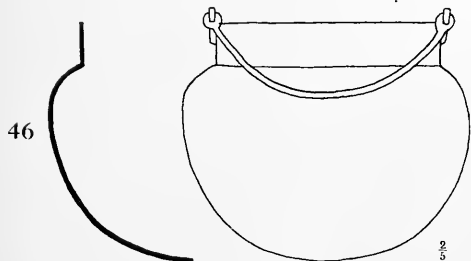
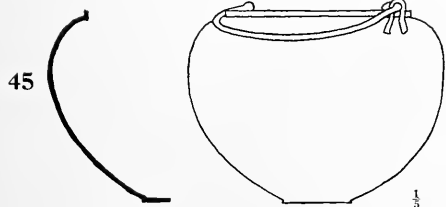
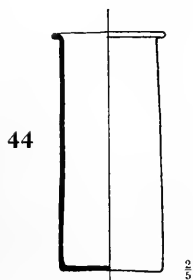
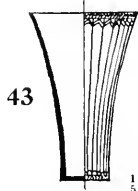
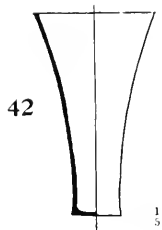

TYPES OF METAL VESSELS

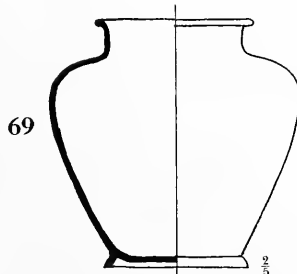
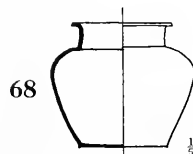
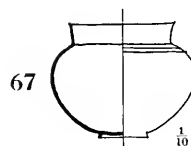
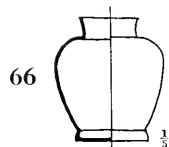
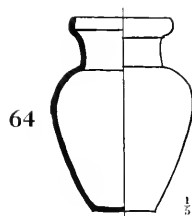
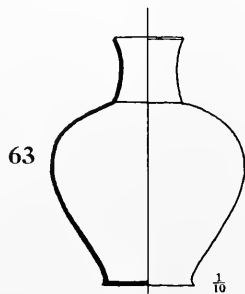
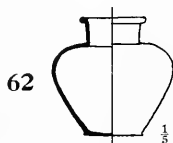
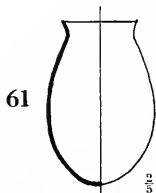
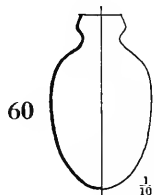
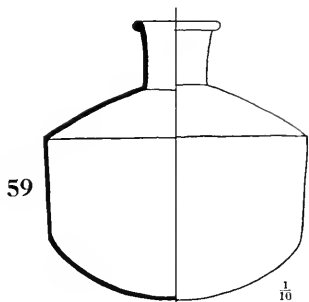
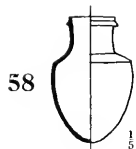
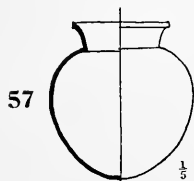
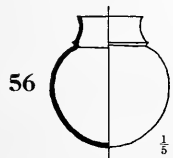
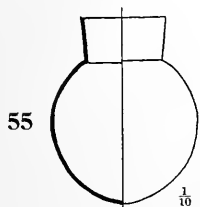
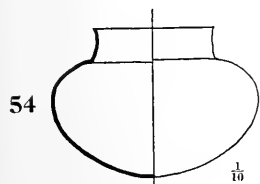
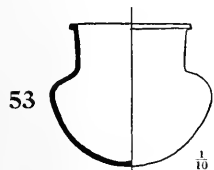
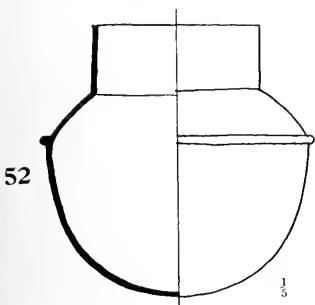

TYPES OF METAL VESSELS

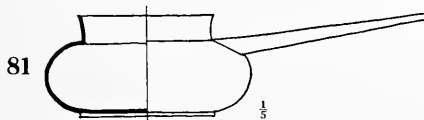
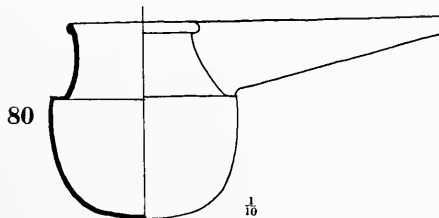
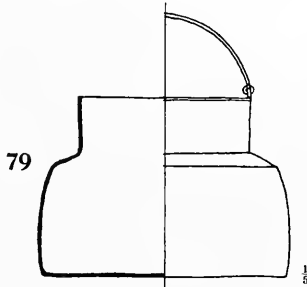
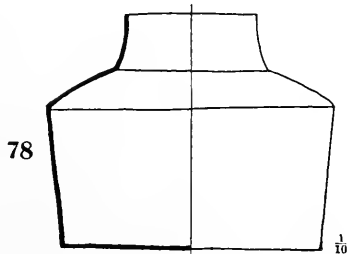
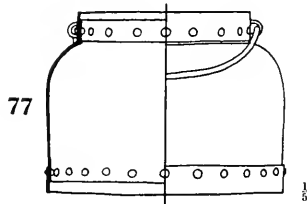
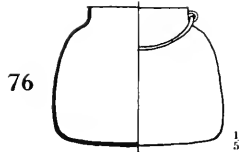
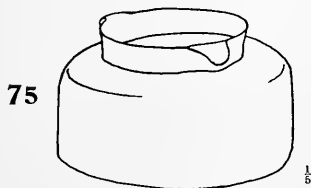
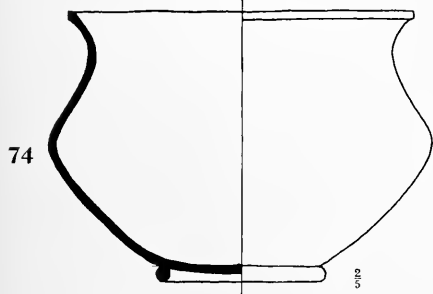
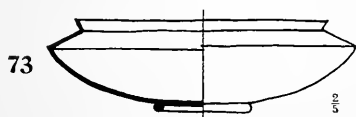
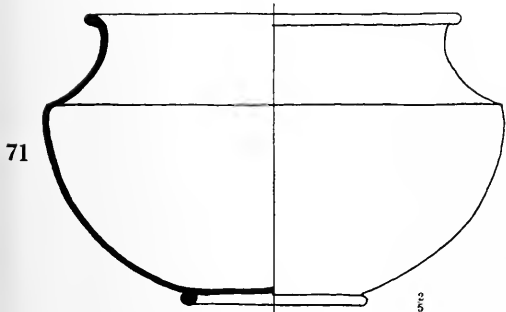
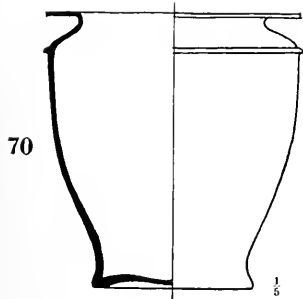

TYPES OF METAL VESSELS

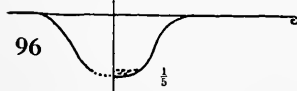
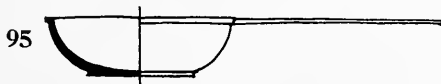
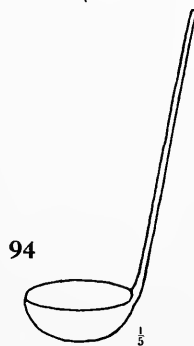
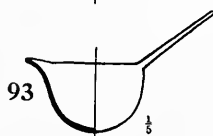
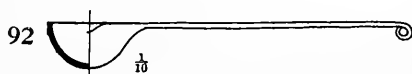
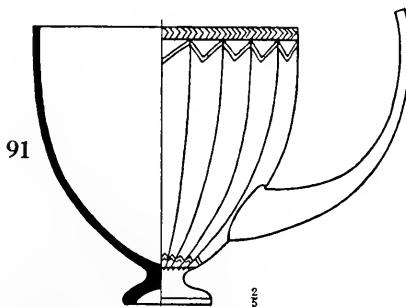
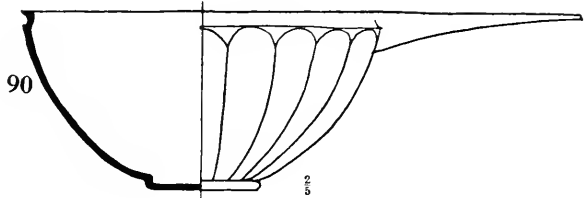
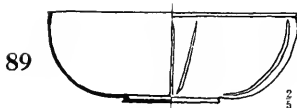
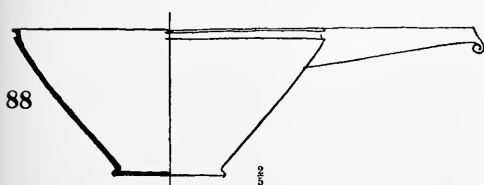
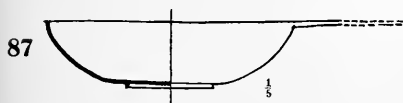
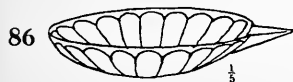
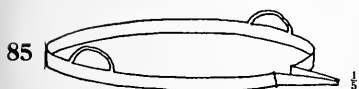
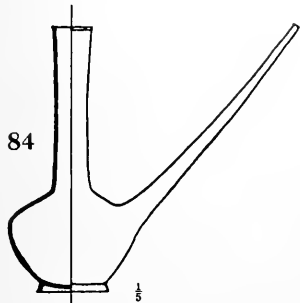
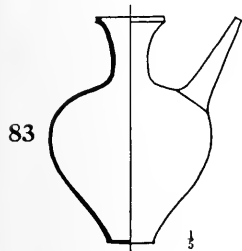
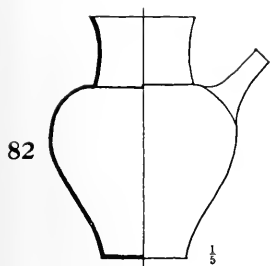

TYPES OF METAL VESSELS

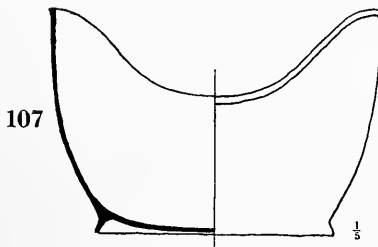
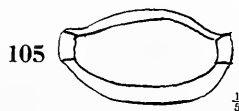
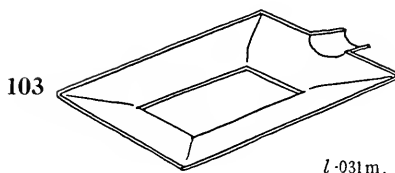
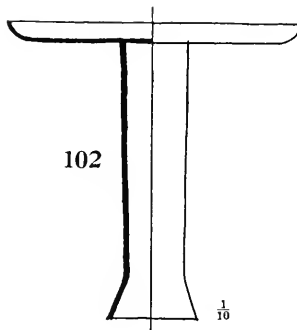
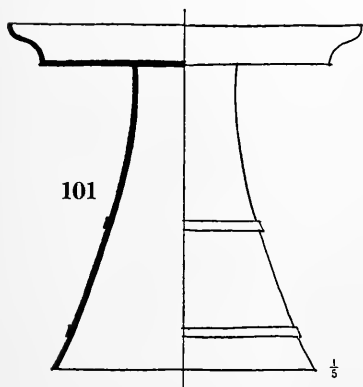
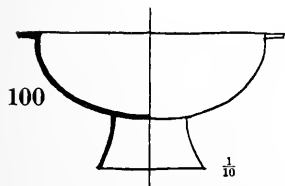
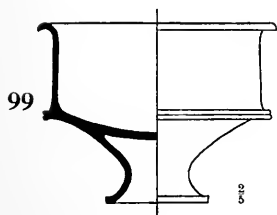
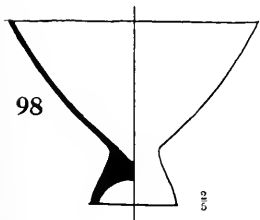
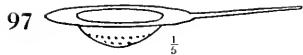

TYPES OF METAL VESSELS

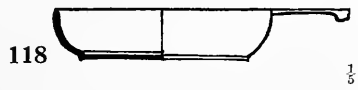
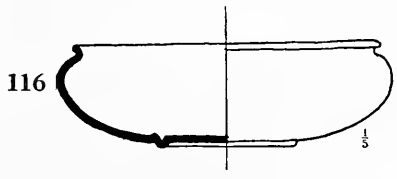
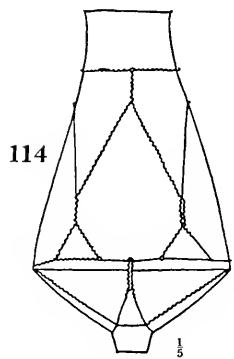
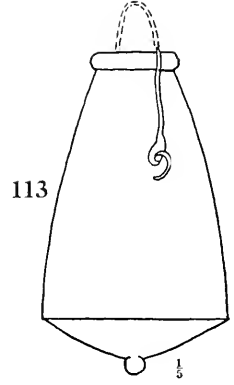
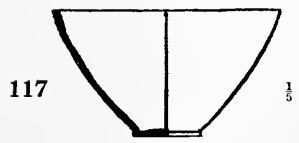
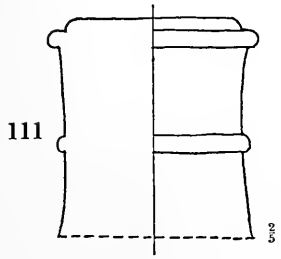
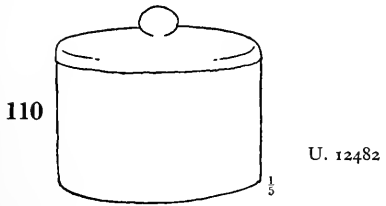
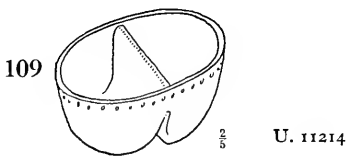
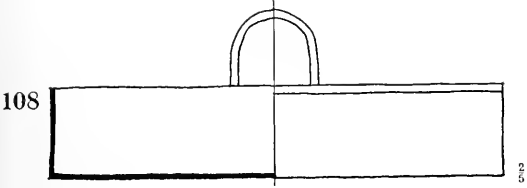

TYPES OF METAL VESSELS

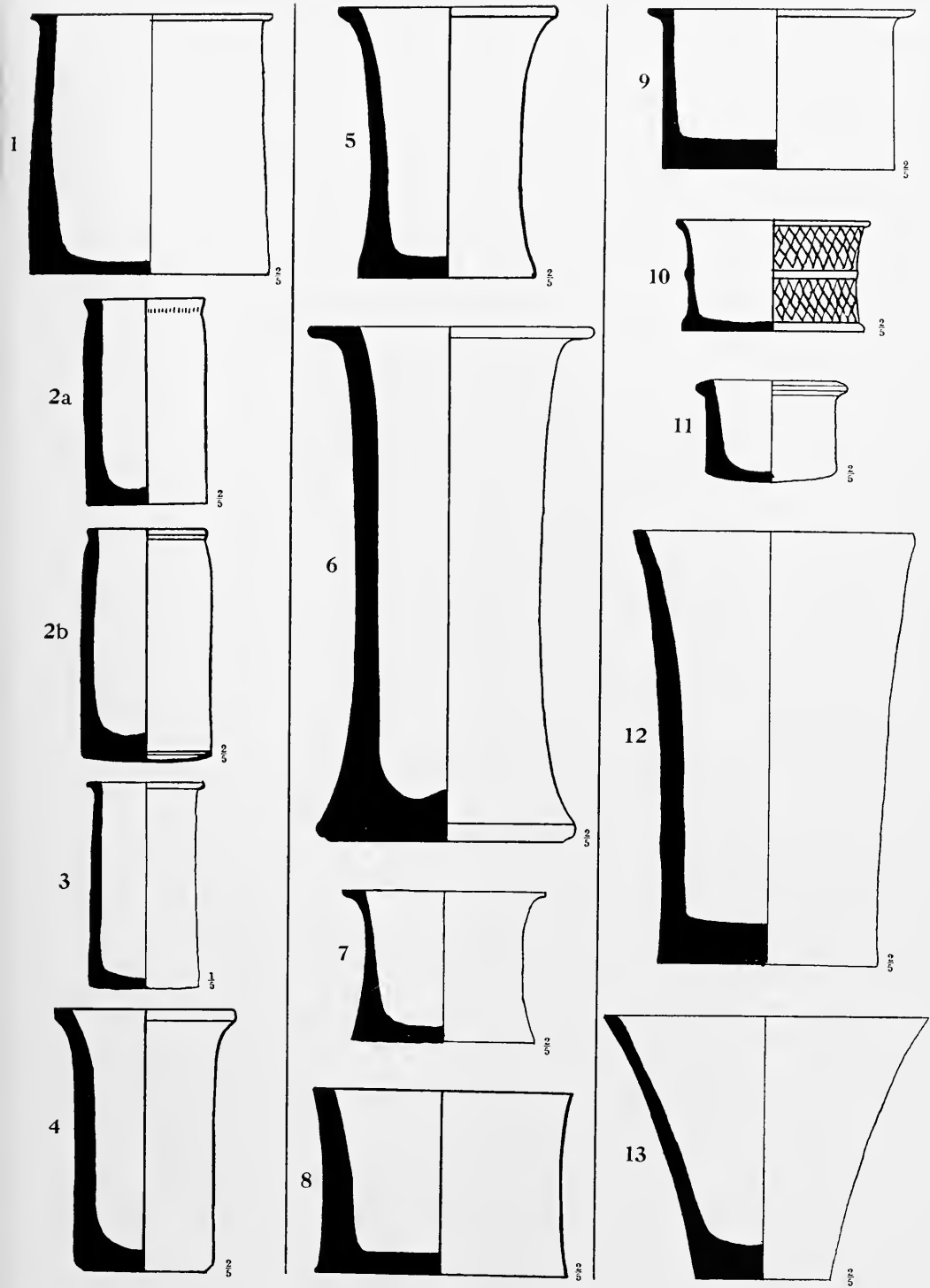

TYPES OF STONE VESSELS

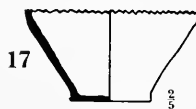
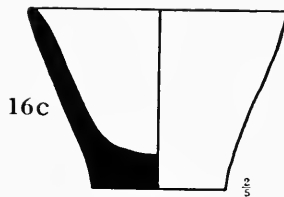
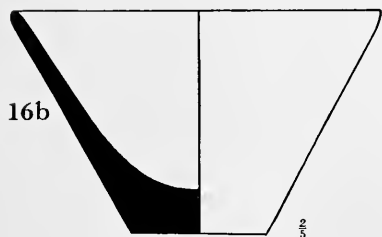
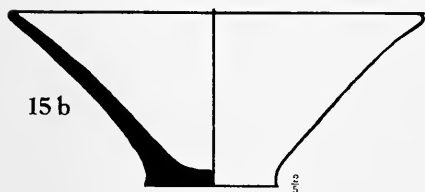
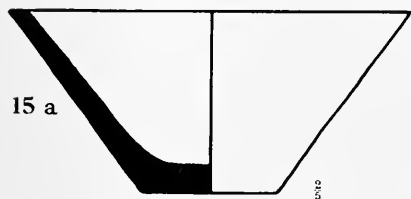
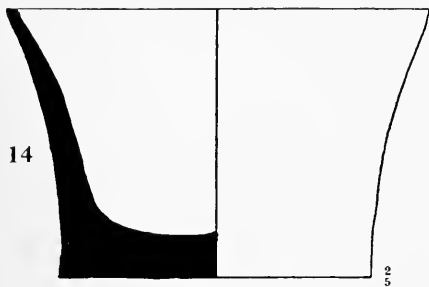

TYPES OF STONE VESSELS

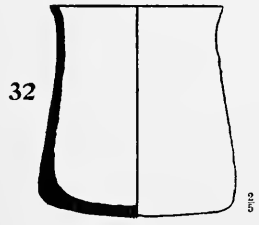
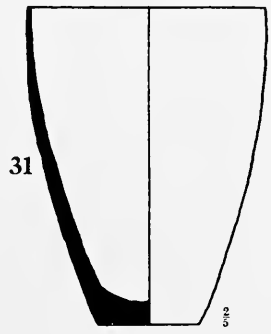
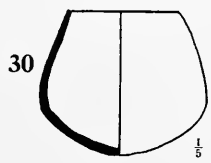
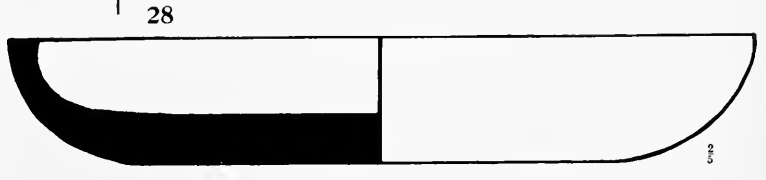
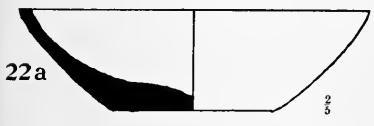

TYPES OF STONE VESSELS

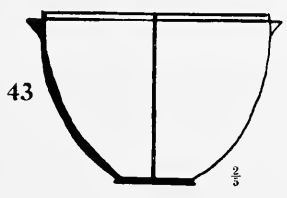
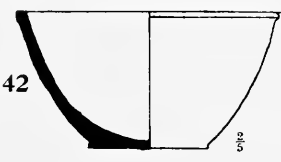
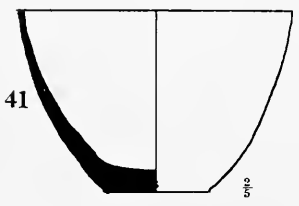
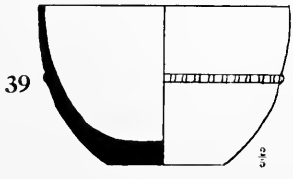
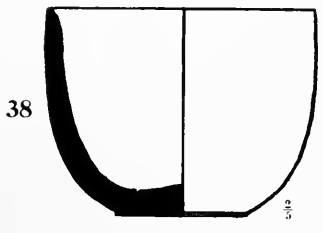
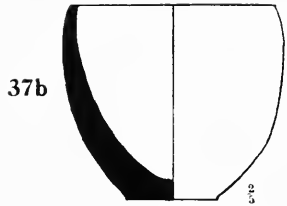
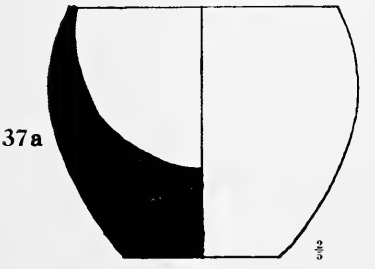
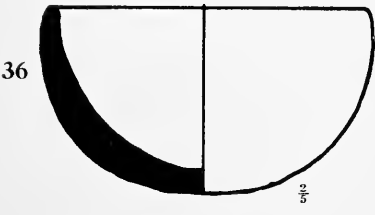
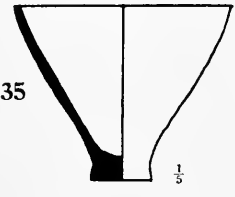
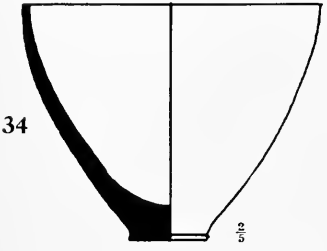
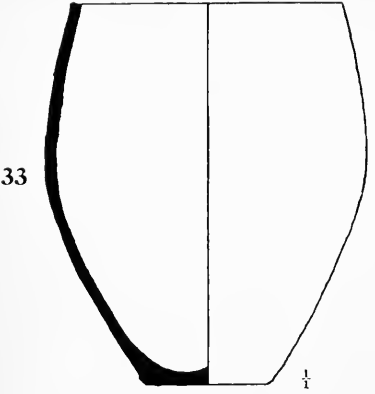

TYPES OF STONE VESSELS

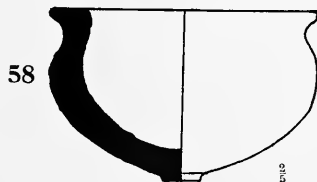
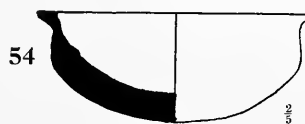
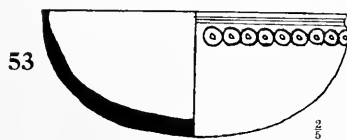
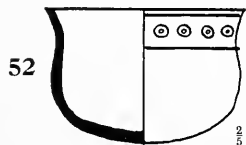
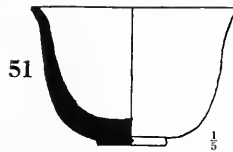
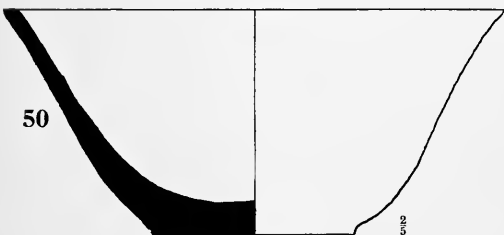
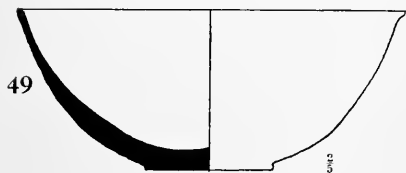
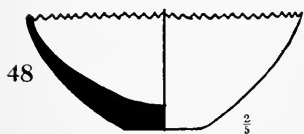
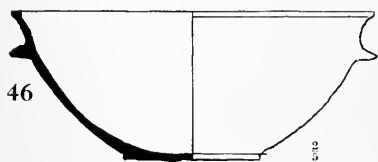
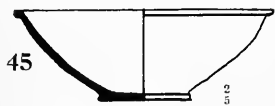
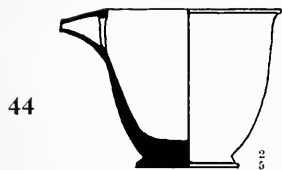

TYPES OF STONE VESSELS

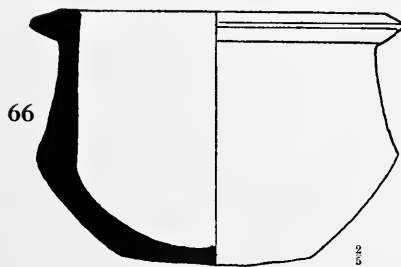
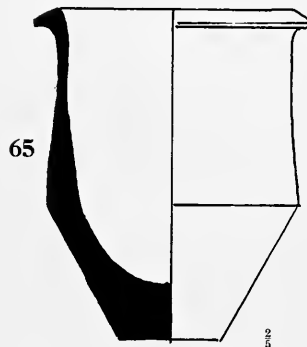
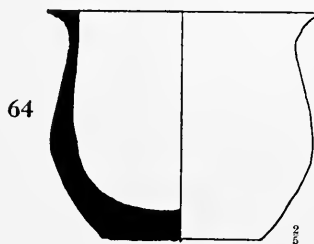
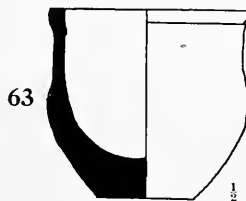
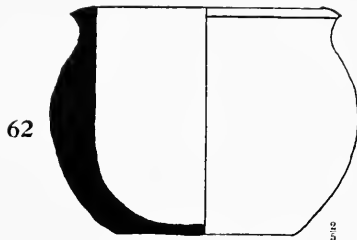
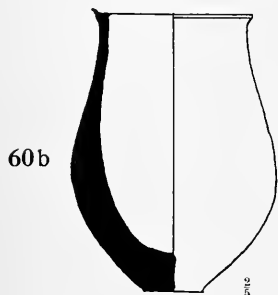
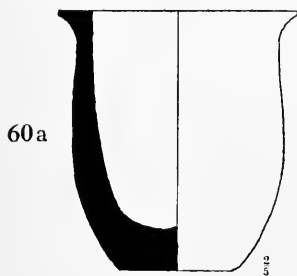
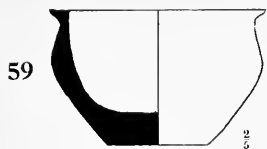

TYPES OF STONE VESSELS

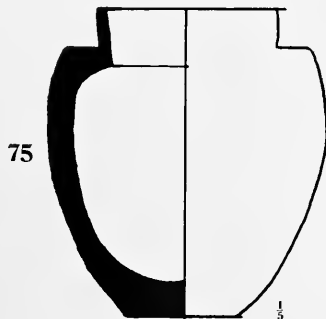
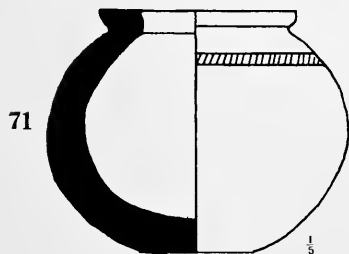
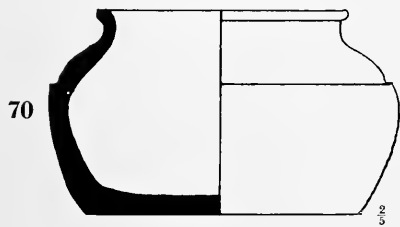
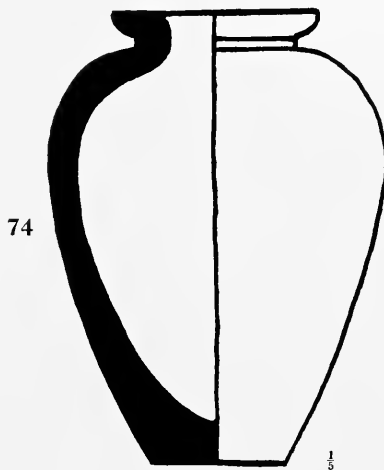
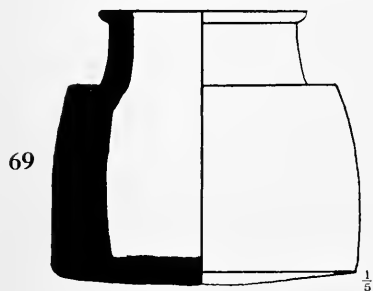
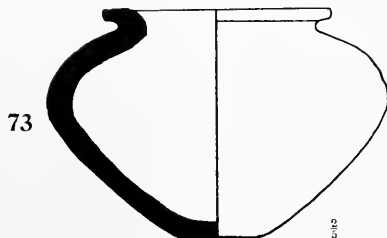
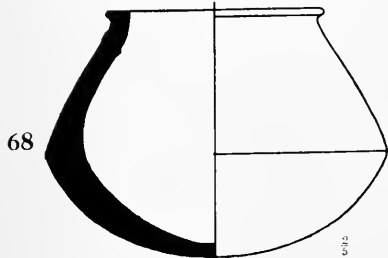
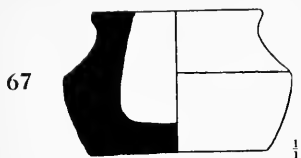

TYPES OF STONE VESSELS

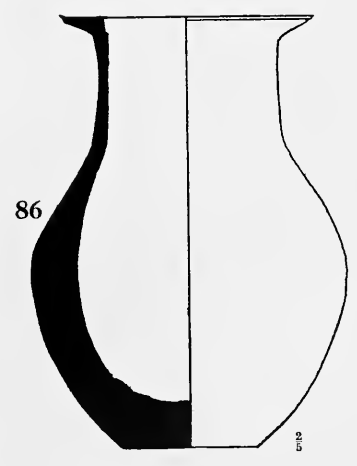
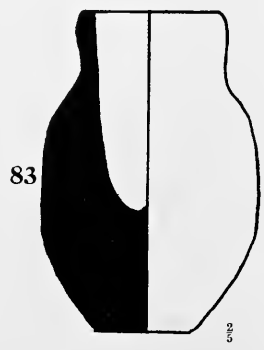
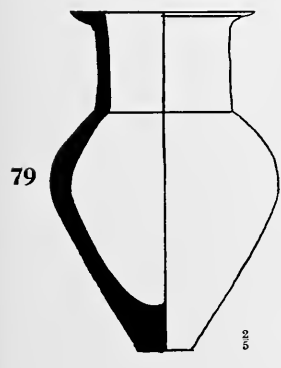
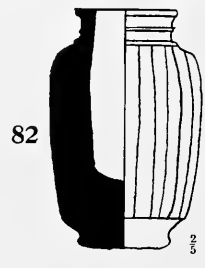
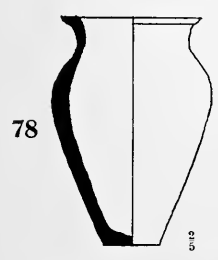
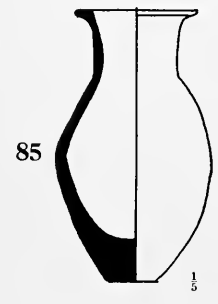
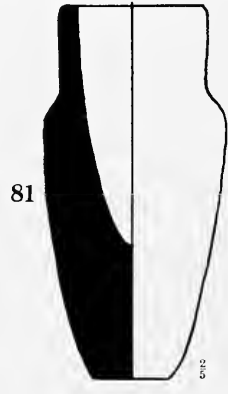
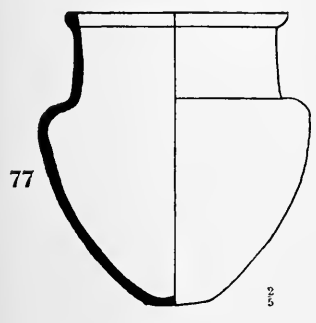
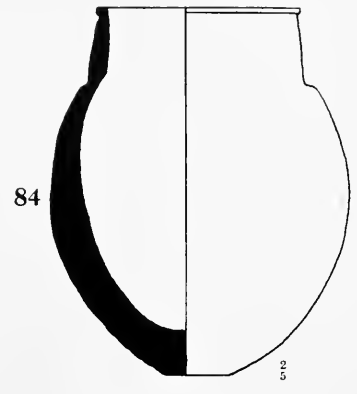
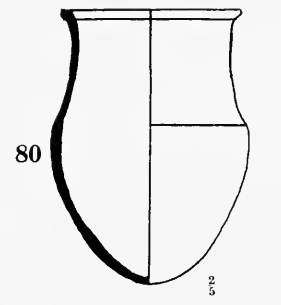
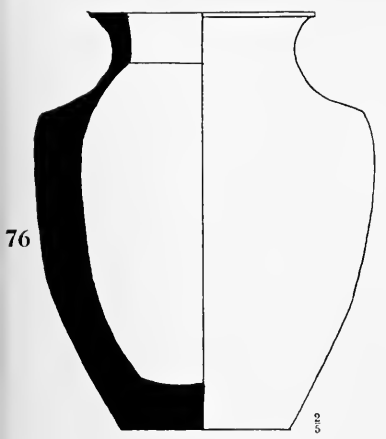

TYPES OF STONE VESSELS

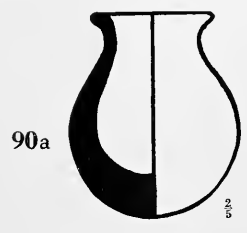
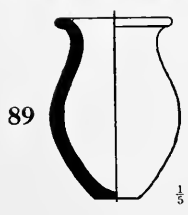
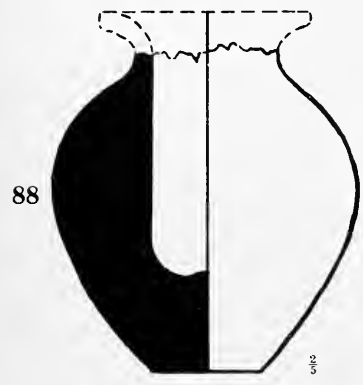
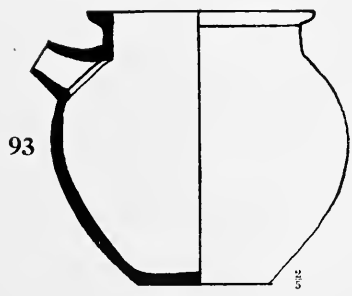
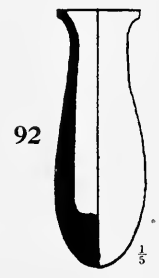
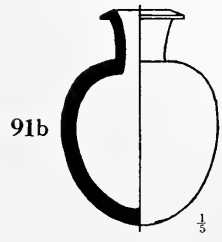
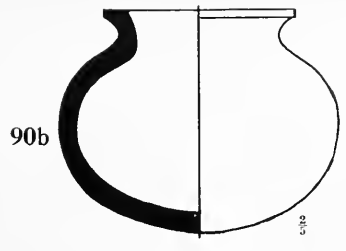
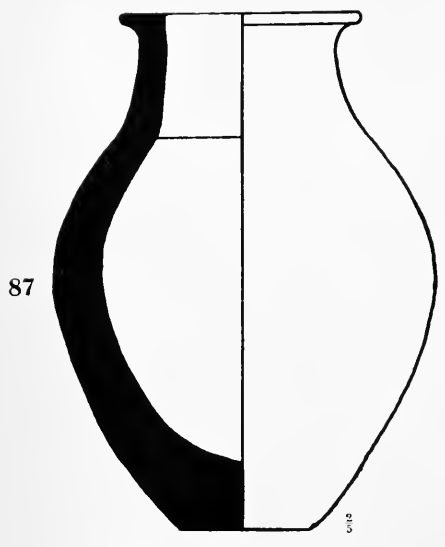

TYPES OF STONE VESSELS

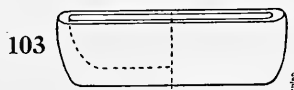
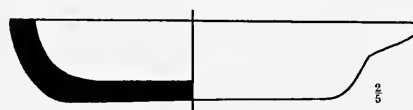
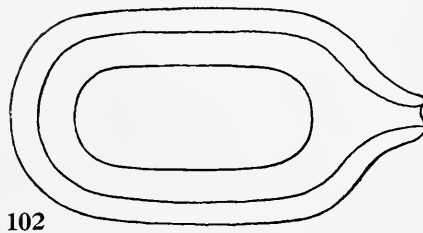
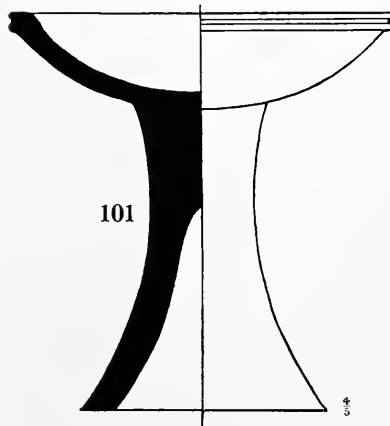
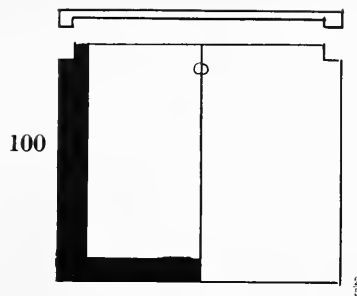
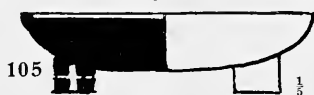
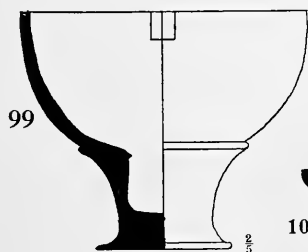
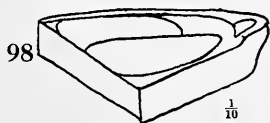
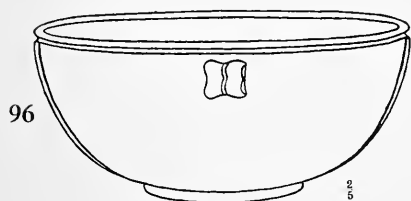
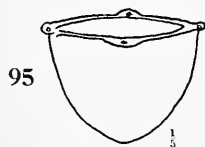
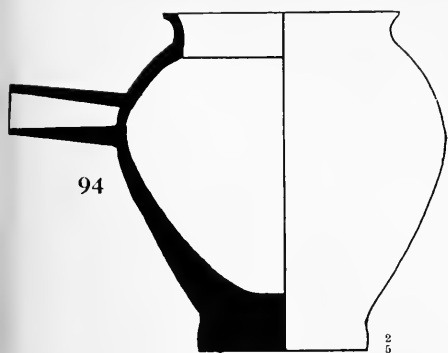

TYPES OF STONE VESSELS

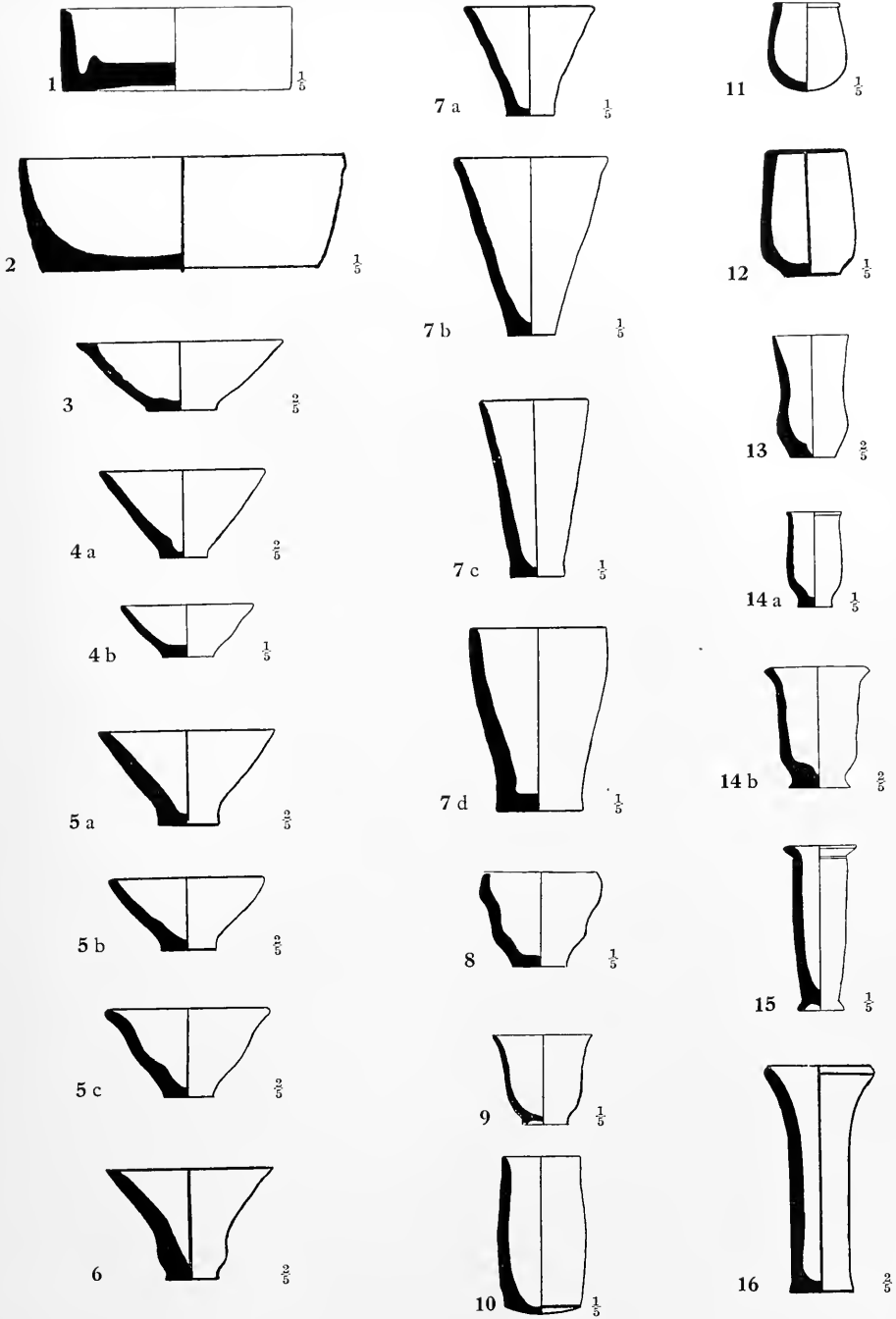

TYPES OF CLAY VESSELS

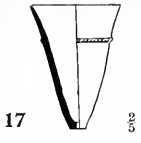

17



25

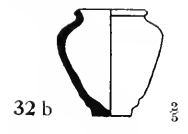

32 b



18 a

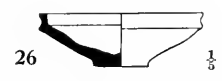

26

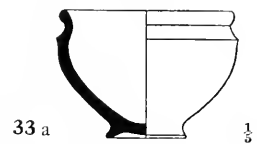

33 a



18 b



27

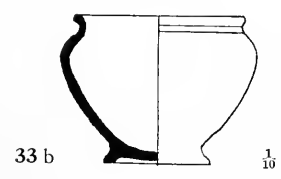

33 b



19

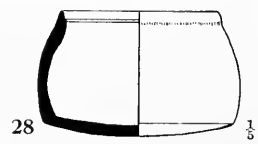

28

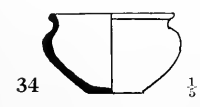

34



20 a



29



35



20 b



30 a

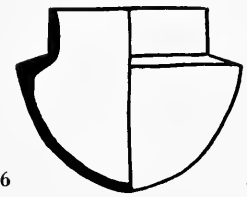

36



21



30 b



37



22



31

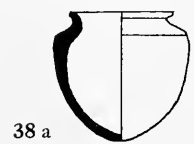

38 a



23

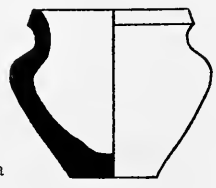

32 a

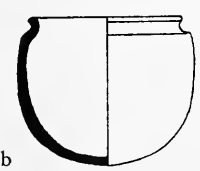

38 b



24

TYPES OF CLAY VESSELS

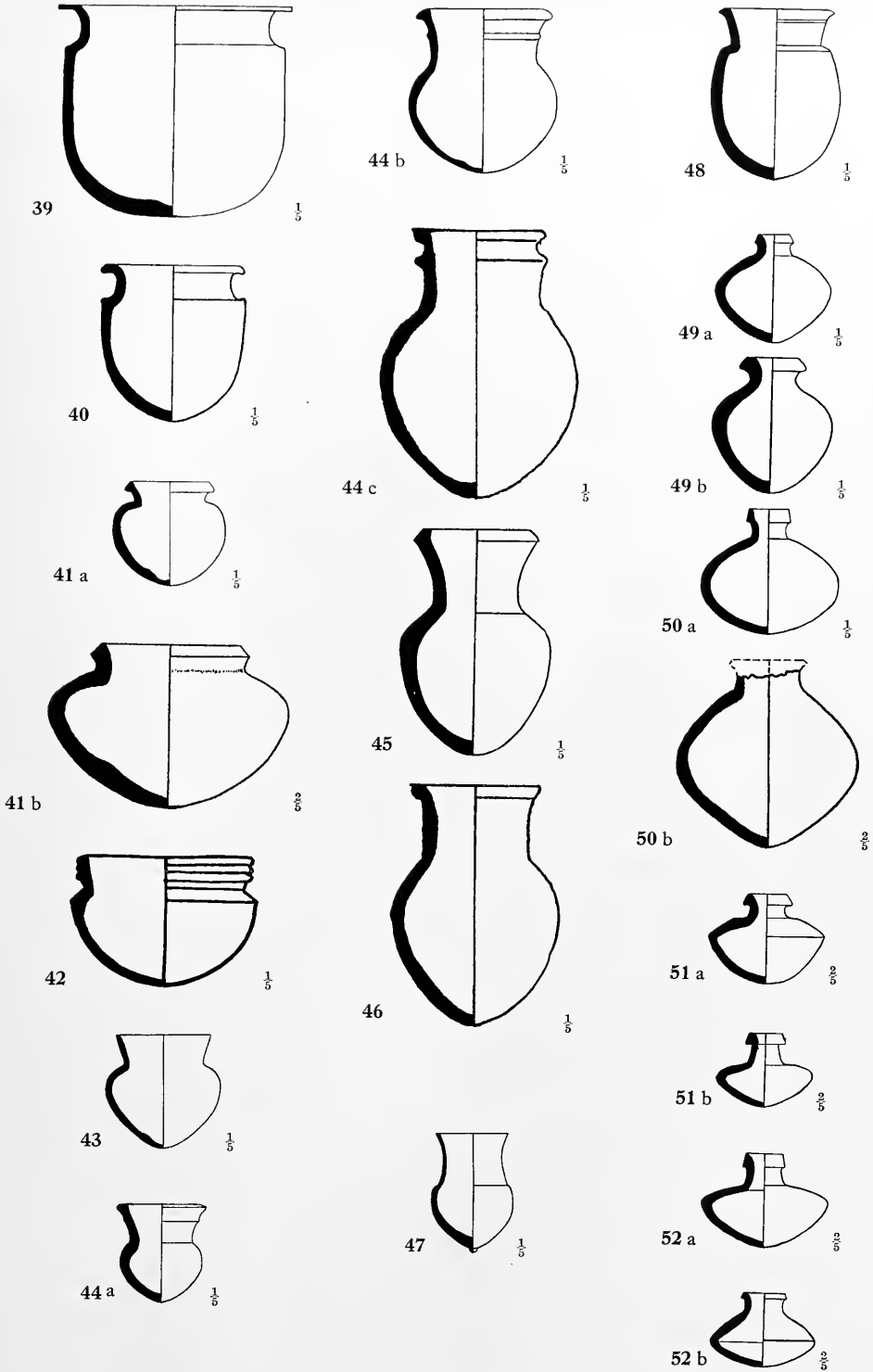

TYPES OF CLAY VESSELS

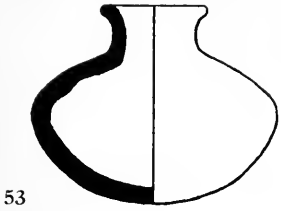

53

1/5

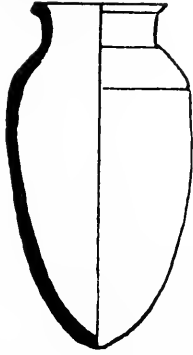

58

1/5

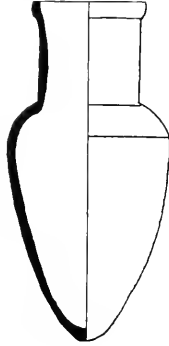

62

1/5

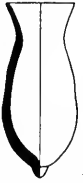

54

1/5



59

1/10

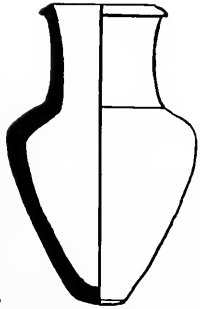

63

1/5



55

1/5

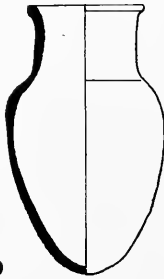

60

1/5



64

1/5

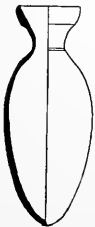

56

1/5



65

1/10



57

1/5



61

1/5



66

1/5

TYPES OF CLAY VESSELS

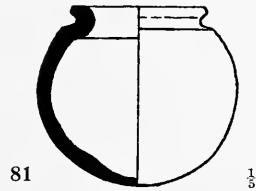
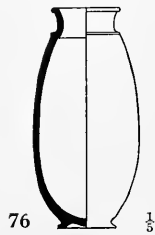
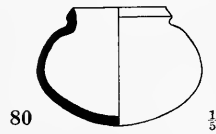
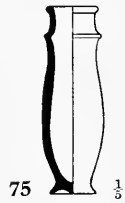
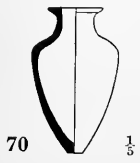
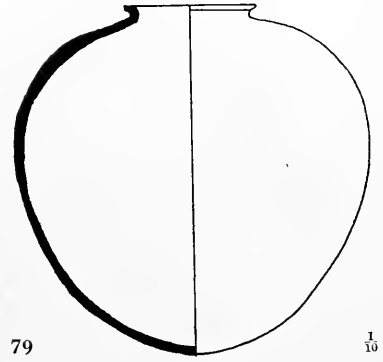
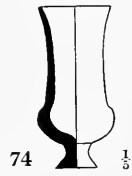
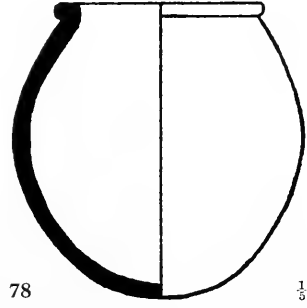
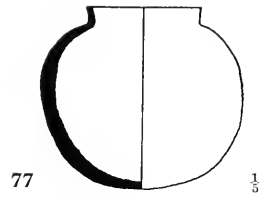
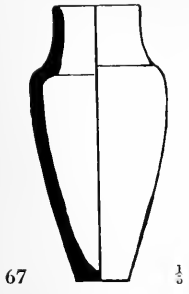

TYPES OF CLAY VESSELS



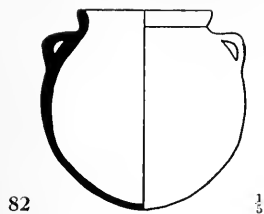

82

$\frac{1}{5}$



83 a

$\frac{1}{5}$

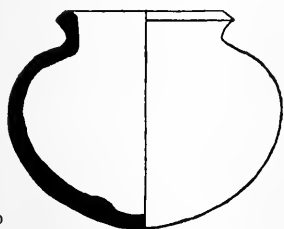

83 b

$\frac{1}{5}$

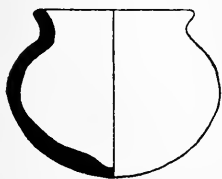

83 c

$\frac{1}{5}$



83 d

$\frac{1}{5}$



84

$\frac{1}{5}$



85

$\frac{1}{5}$



86

$\frac{1}{5}$

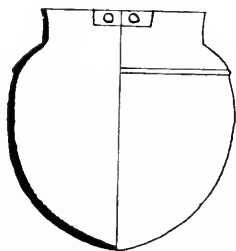

87

$\frac{1}{5}$



88 a

$\frac{1}{10}$

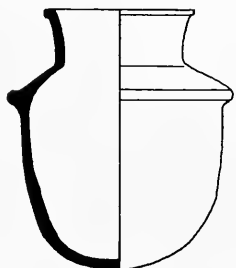

88 b

$\frac{1}{5}$

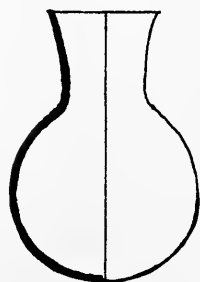

89

$\frac{1}{5}$



90

$\frac{1}{5}$

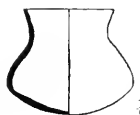

91

$\frac{1}{5}$

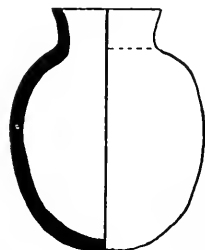

92

$\frac{1}{5}$



93

$\frac{1}{5}$

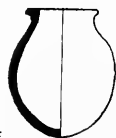

94

$\frac{1}{5}$



95

$\frac{1}{5}$

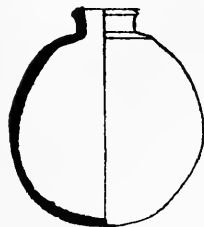

96

$\frac{1}{5}$

TYPES OF CLAY VESSELS

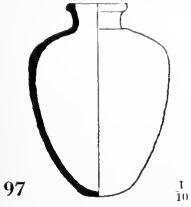

97

$\frac{1}{10}$

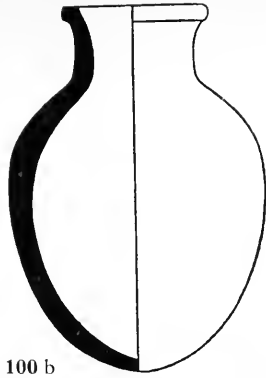

100 b

$\frac{1}{5}$

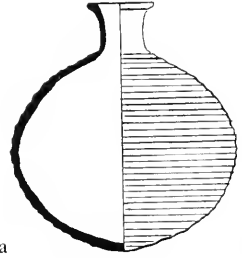

106 a

$\frac{1}{5}$

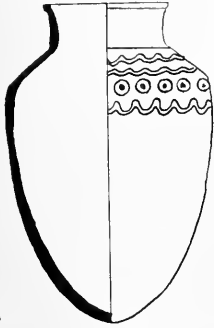

98

$\frac{1}{5}$

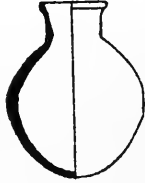

101

$\frac{1}{10}$

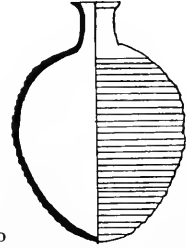

106 b

$\frac{1}{5}$

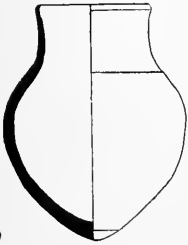

99

$\frac{1}{5}$



102

$\frac{1}{10}$

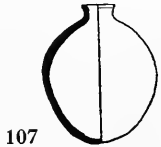

107

$\frac{1}{10}$

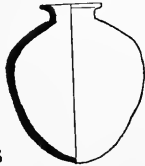

103

$\frac{1}{10}$

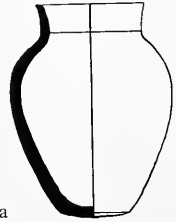

108 a

$\frac{1}{5}$

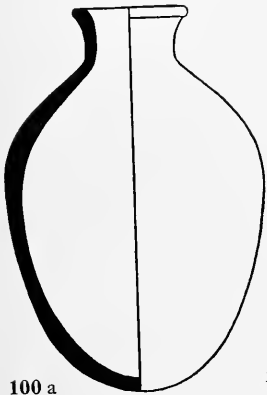

100 a

$\frac{1}{5}$

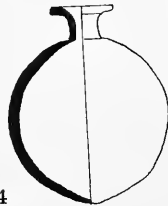

104

$\frac{1}{5}$



108 b

$\frac{1}{5}$

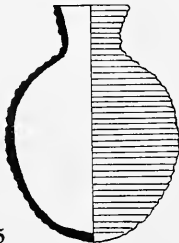

105

$\frac{1}{5}$



108 c

$\frac{1}{5}$

TYPES OF CLAY VESSELS

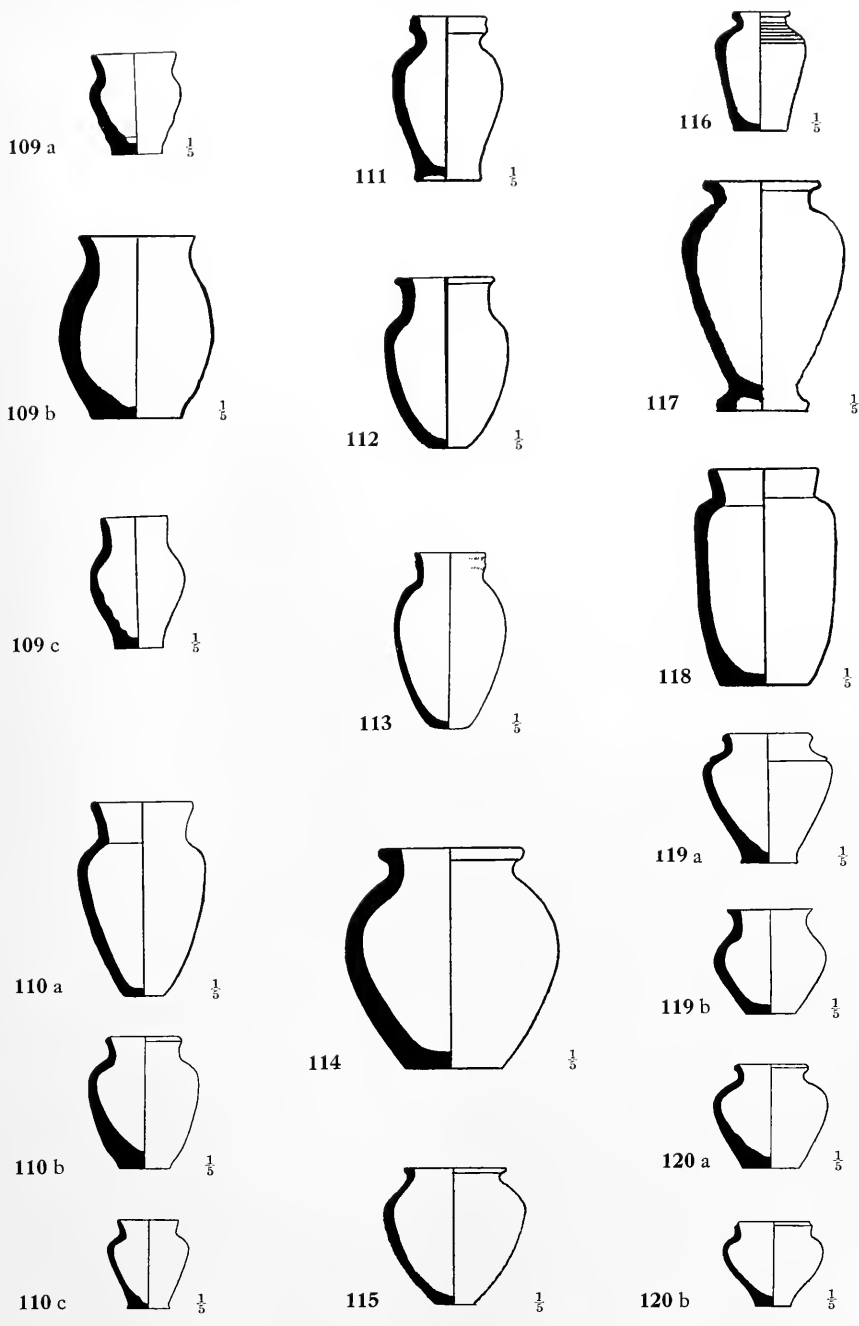

TYPES OF CLAY VESSELS

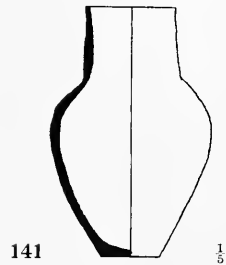
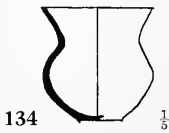
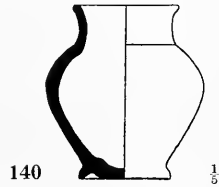
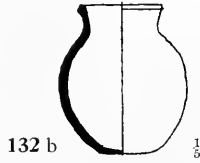
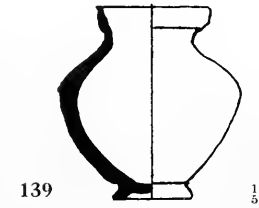
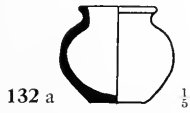
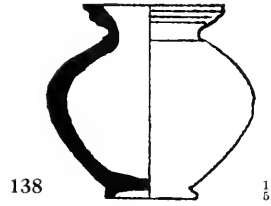
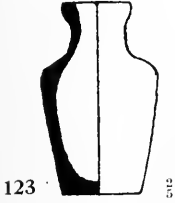
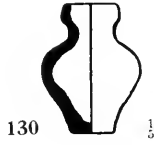
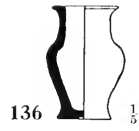

TYPES OF CLAY VESSELS

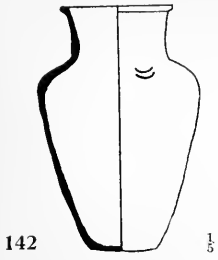

142

$\frac{1}{5}$

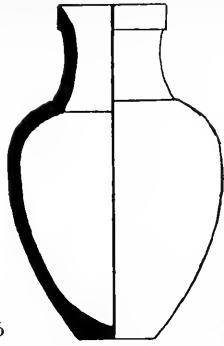

146

$\frac{1}{5}$

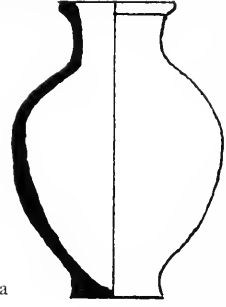

150 a

$\frac{1}{5}$

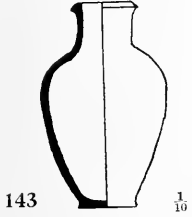

143

$\frac{1}{10}$

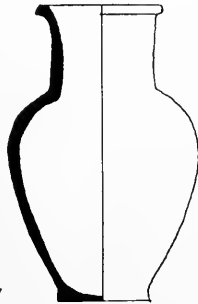

147

$\frac{1}{5}$

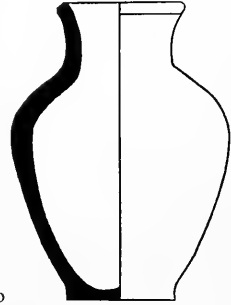

150 b

$\frac{1}{5}$

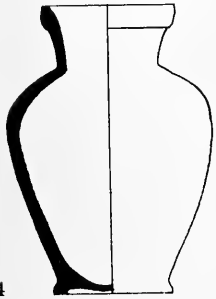

144

$\frac{1}{5}$

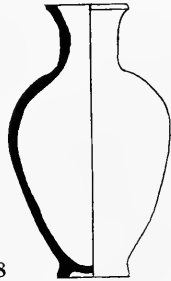

148

$\frac{1}{10}$

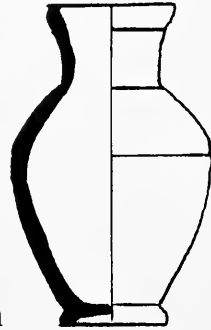

151

$\frac{1}{5}$

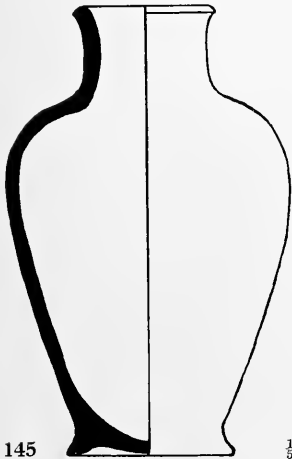

145

$\frac{1}{5}$

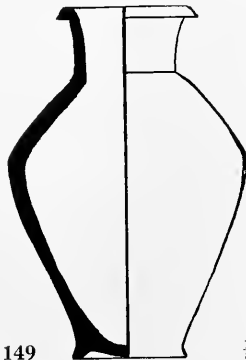

149

$\frac{1}{5}$



152

$\frac{1}{10}$

TYPES OF CLAY VESSELS



153

$\frac{1}{8}$

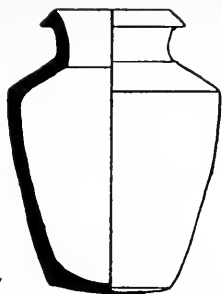

157

$\frac{1}{8}$

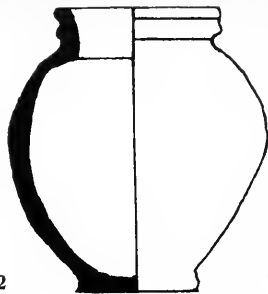

162

$\frac{1}{8}$

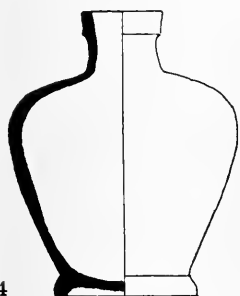

154

$\frac{1}{10}$

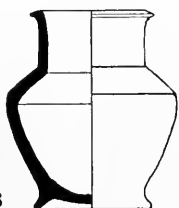

158

$\frac{1}{8}$

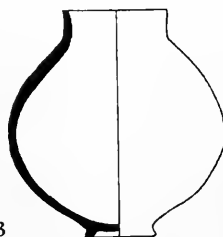

163

$\frac{1}{8}$

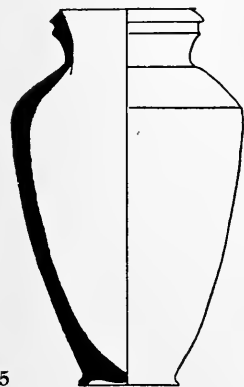

155

$\frac{1}{8}$

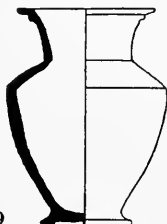

159

$\frac{1}{8}$

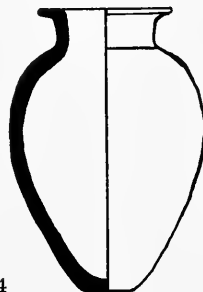

164

$\frac{1}{8}$

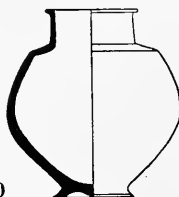

160

$\frac{1}{8}$



156

$\frac{1}{10}$

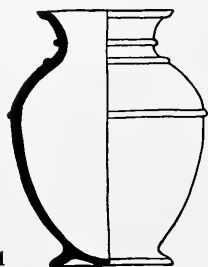

161

$\frac{1}{8}$



165

$\frac{1}{8}$

TYPES OF CLAY VESSELS



166



171

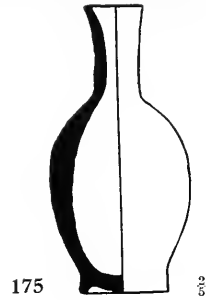

175

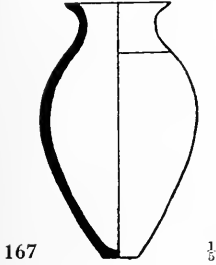

167

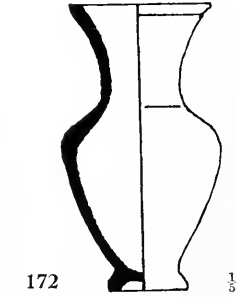

172

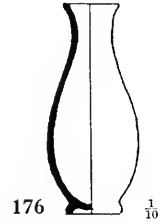

176

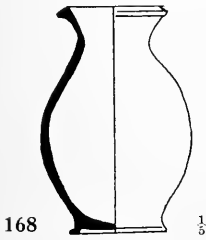

168



177

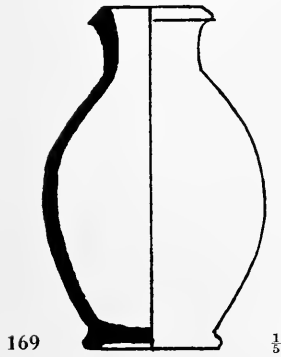

169

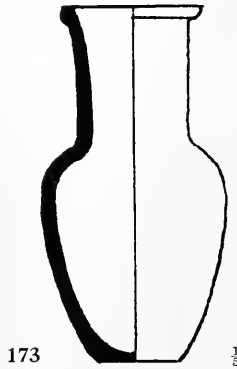

173



178



179 a

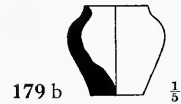

179 b

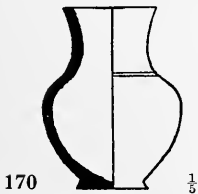

170

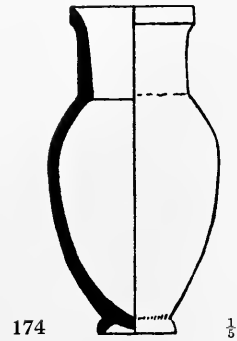

174

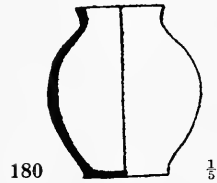

180



181

TYPES OF CLAY VESSELS



182

$\frac{1}{5}$

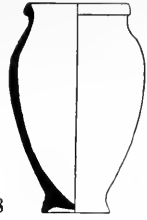

188

$\frac{1}{5}$

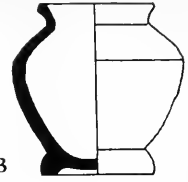

193

$\frac{1}{5}$



183

$\frac{1}{5}$

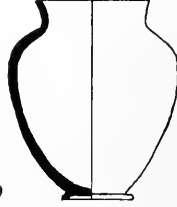

189

$\frac{1}{5}$

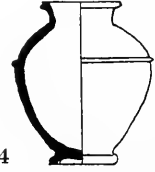

194

$\frac{1}{10}$

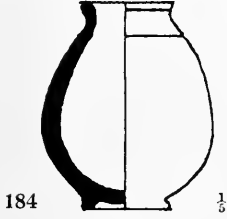

184

$\frac{1}{5}$

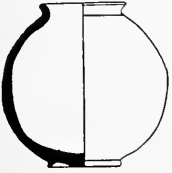

185

$\frac{1}{5}$

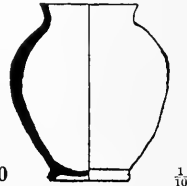

190

$\frac{1}{10}$

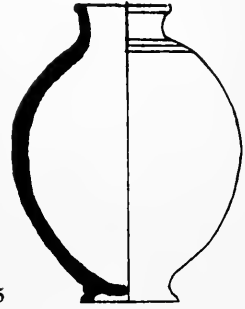

195

$\frac{1}{5}$

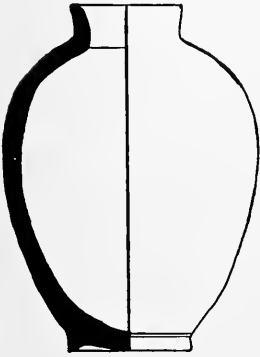

186

$\frac{1}{5}$



191

$\frac{1}{5}$

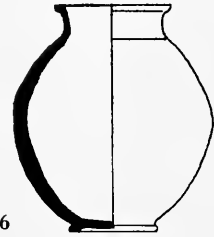

196

$\frac{1}{5}$



187

$\frac{1}{5}$

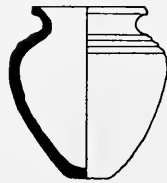

192

$\frac{1}{5}$



197

$\frac{1}{10}$

TYPES OF CLAY VESSELS



198 a

$\frac{1}{5}$

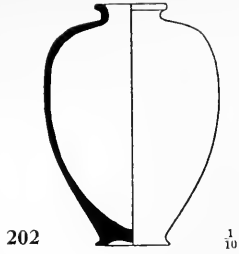

202

$\frac{1}{10}$

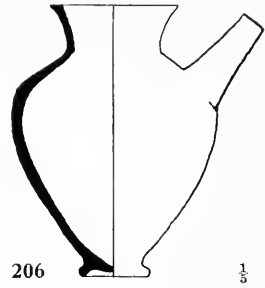

206

$\frac{1}{5}$



198 b

$\frac{1}{5}$

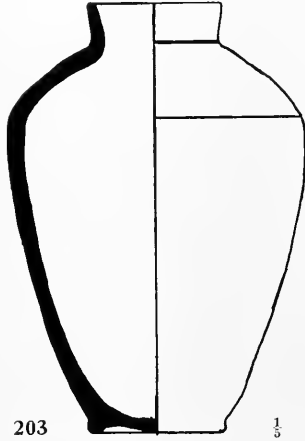

203

$\frac{1}{5}$

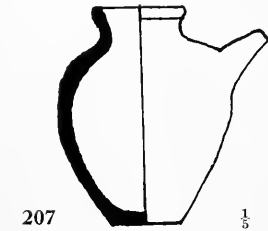

207

$\frac{1}{5}$

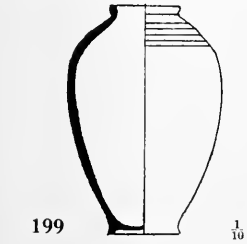

199

$\frac{1}{10}$

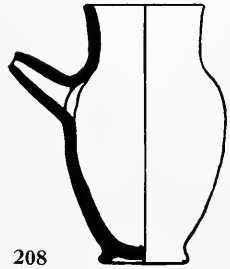

208

$\frac{1}{5}$

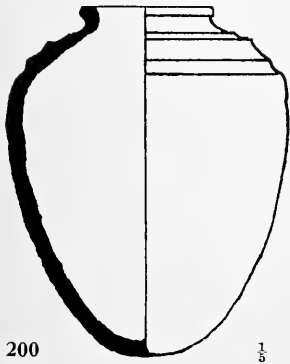

200

$\frac{1}{5}$

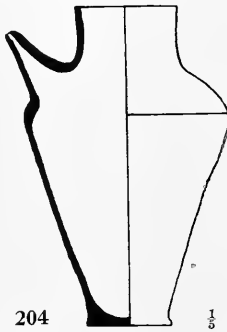

204

$\frac{1}{5}$

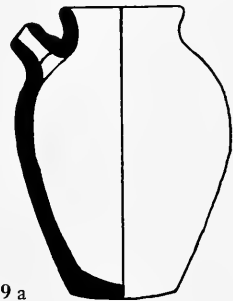

209 a

$\frac{1}{5}$

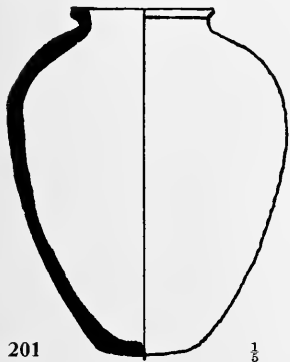

201

$\frac{1}{5}$

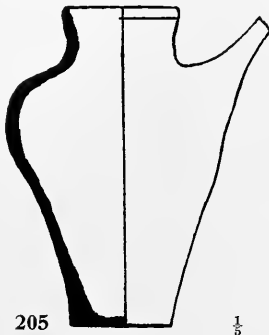

205

$\frac{1}{5}$

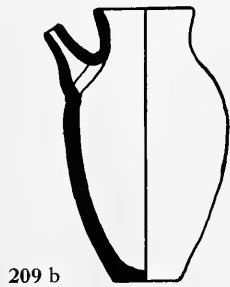

209 b

$\frac{1}{5}$

TYPES OF CLAY VESSELS

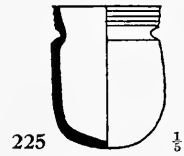
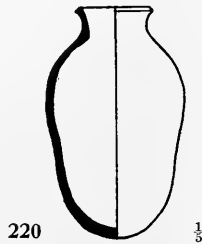
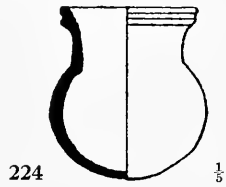
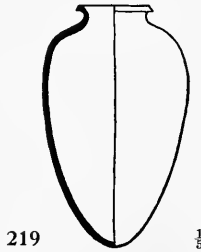
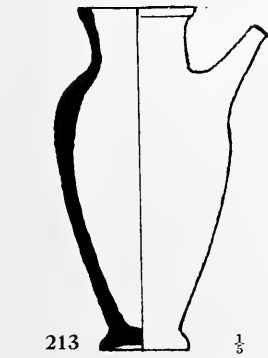
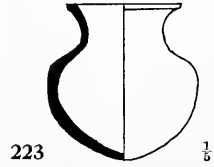
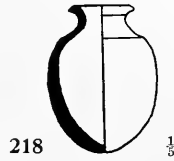
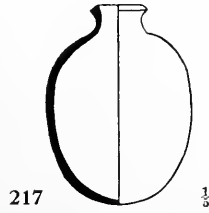
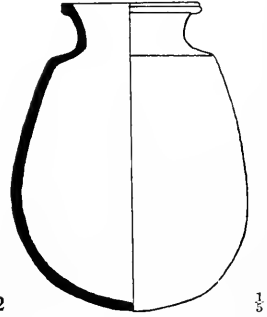
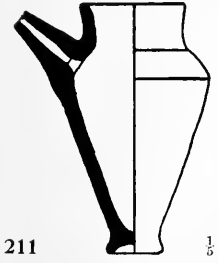
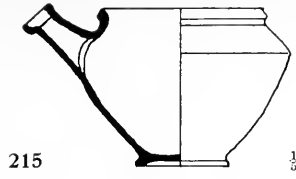
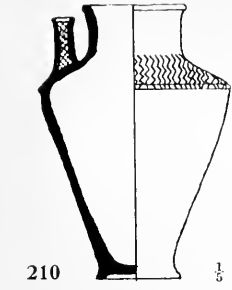

TYPES OF CLAY VESSELS

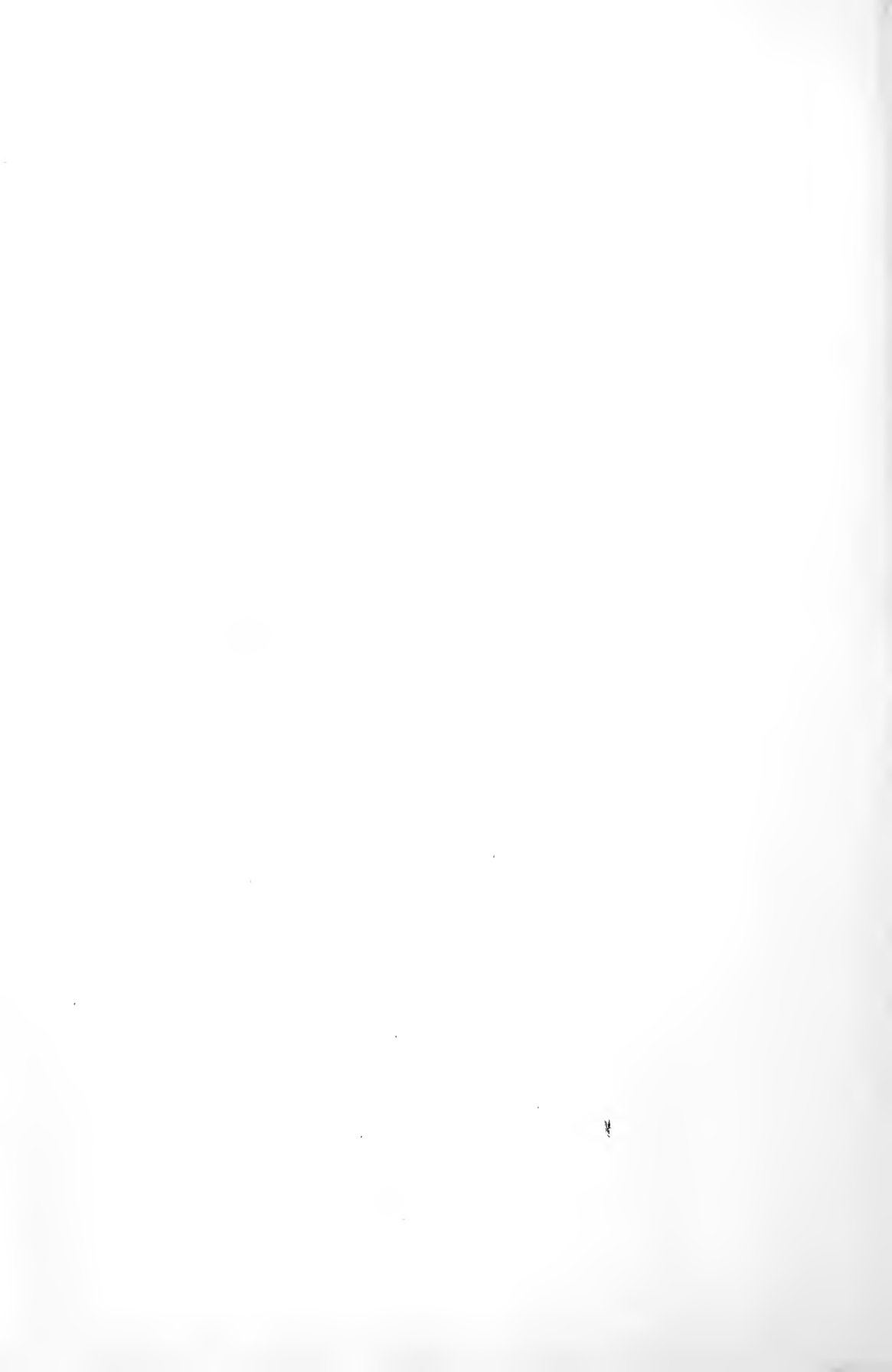

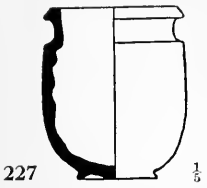

227



234

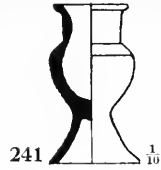

241

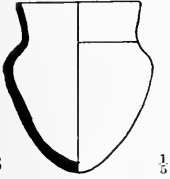

228

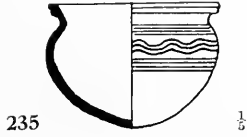

235

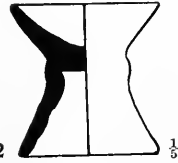

242

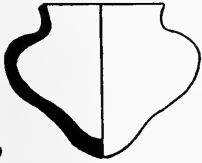

229



236

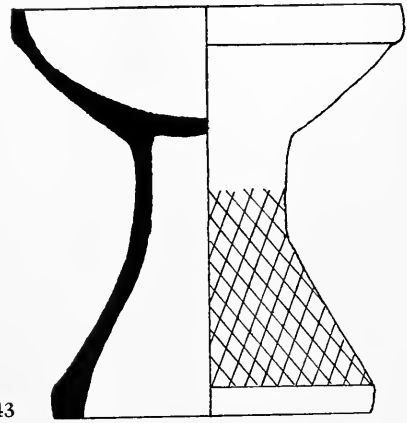

243

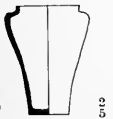

230

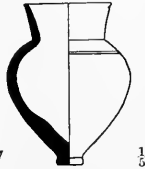

237



231

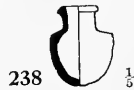

238

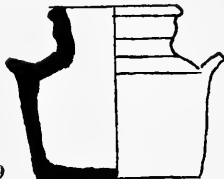

239



244 a



232

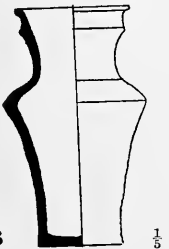

233

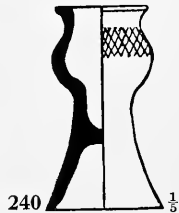

240

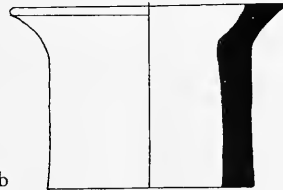

244 b

TYPES OF CLAY VESSELS

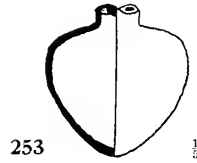
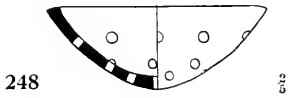
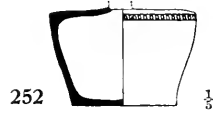
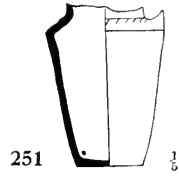
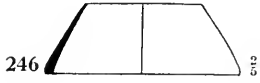
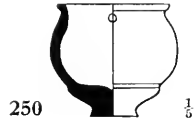
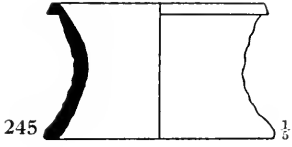

TYPES OF CLAY VESSELS

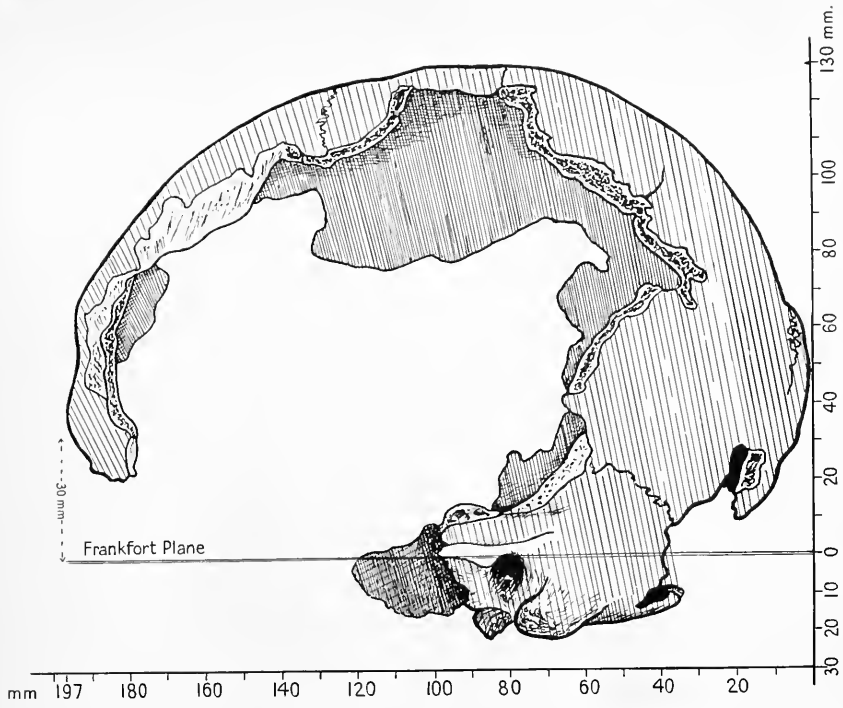

Fig. 1. Drawing of the skull of Queen Shub-ad, as seen in true profile. The skull has been oriented on the Frankfort plane. (Drawn by E. NOON)

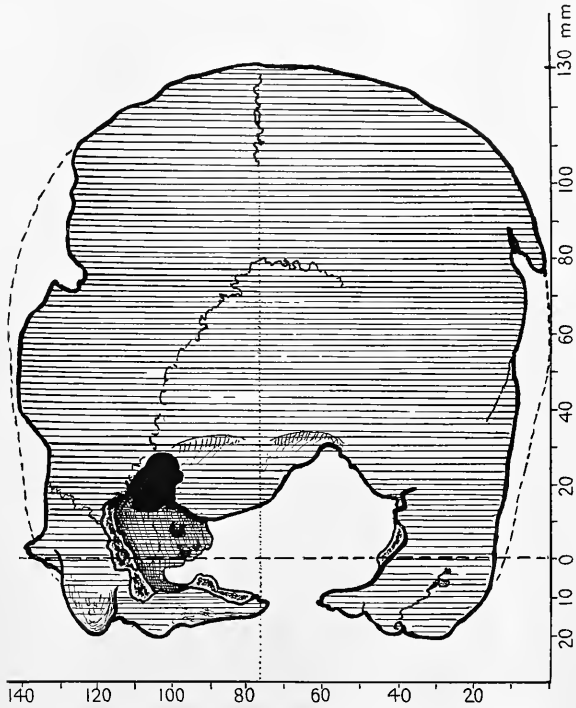

Fig. 2. Drawing of Queen Shub-ad's skull as seen from behind—with the skull oriented on the Frankfort Plane. (Drawn by E. NOON)

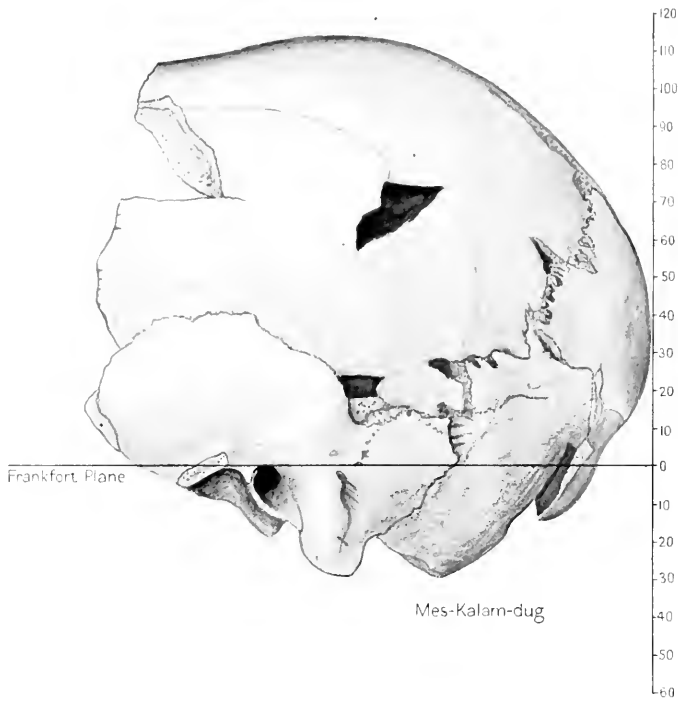

Fig. 1. Exact drawing of the skull of Mes-kalam-dug as seen in profile. The skull has been oriented on the Frankfort plane. (Drawn by E. J. SMITH)

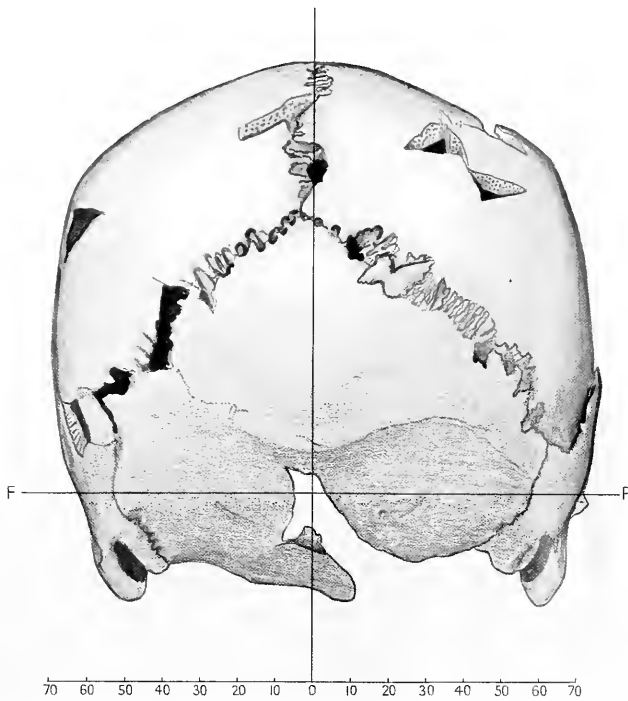
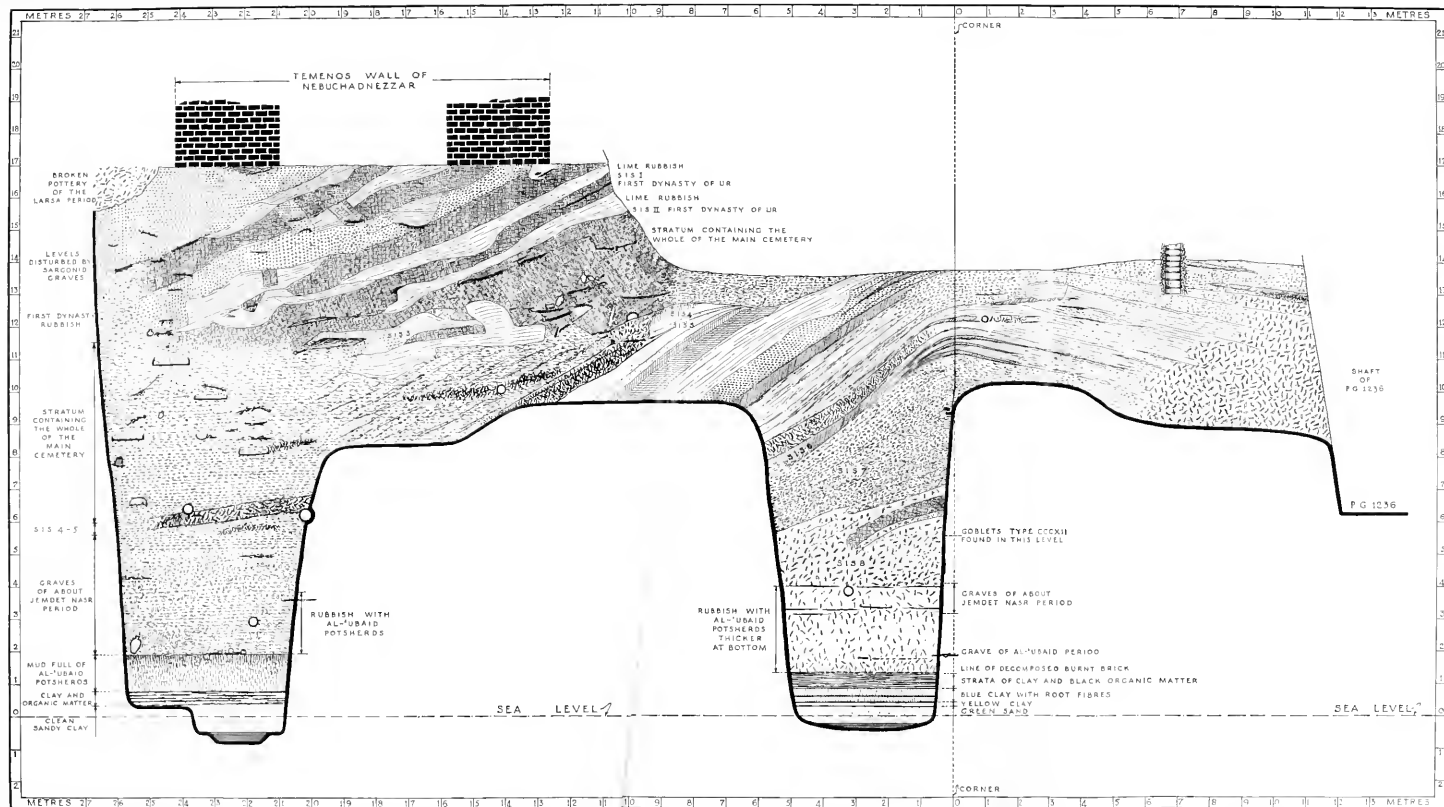

Fig. 2. The skull of Mes-kalam-dug oriented on the Frankfort plane and drawn from behind. F.P. = Frankfort plane. (Drawn by E. J. SMITH)



STRATA ON THE FACE OF THE CUTTINGS AT THE SW. END OF THE CEMETERY EXCAVATIONS

CI Pl. 10 a and p. 220

Scale 0 1 2 3 4 5 metres

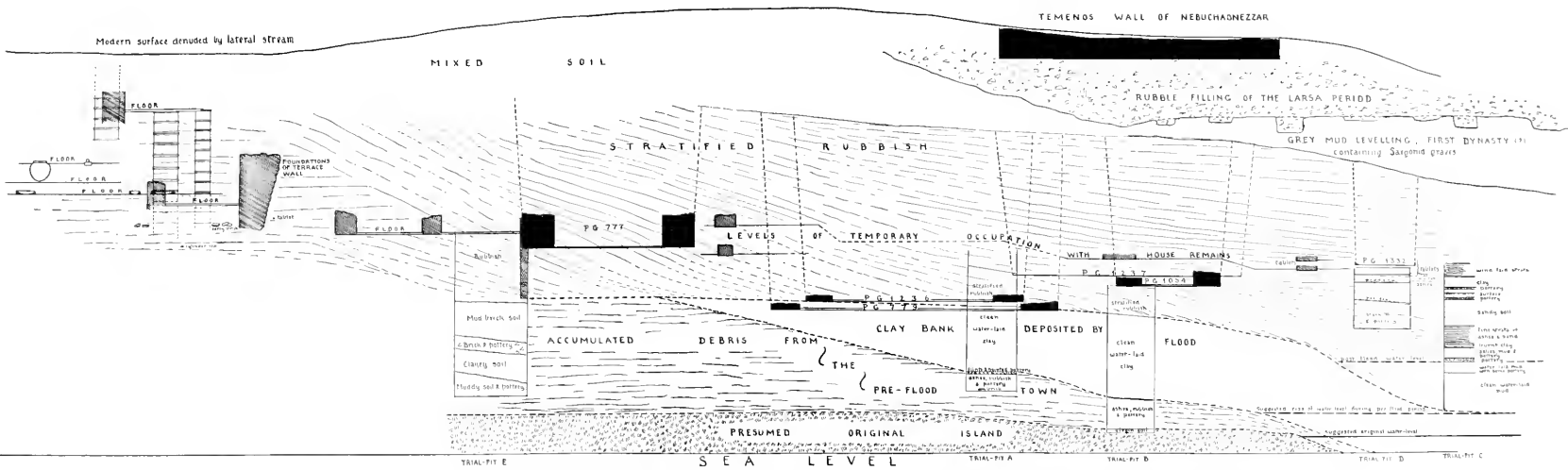

SECTION THROUGH PART OF THE CEMETERY AREA, ILLUSTRATING THE GROWTH OF THE RUBBISH-MOUNDS

The section is based on the data of the trial-pits here marked: these were sunk at various spots but to complete the section have been brought schematically to one plane



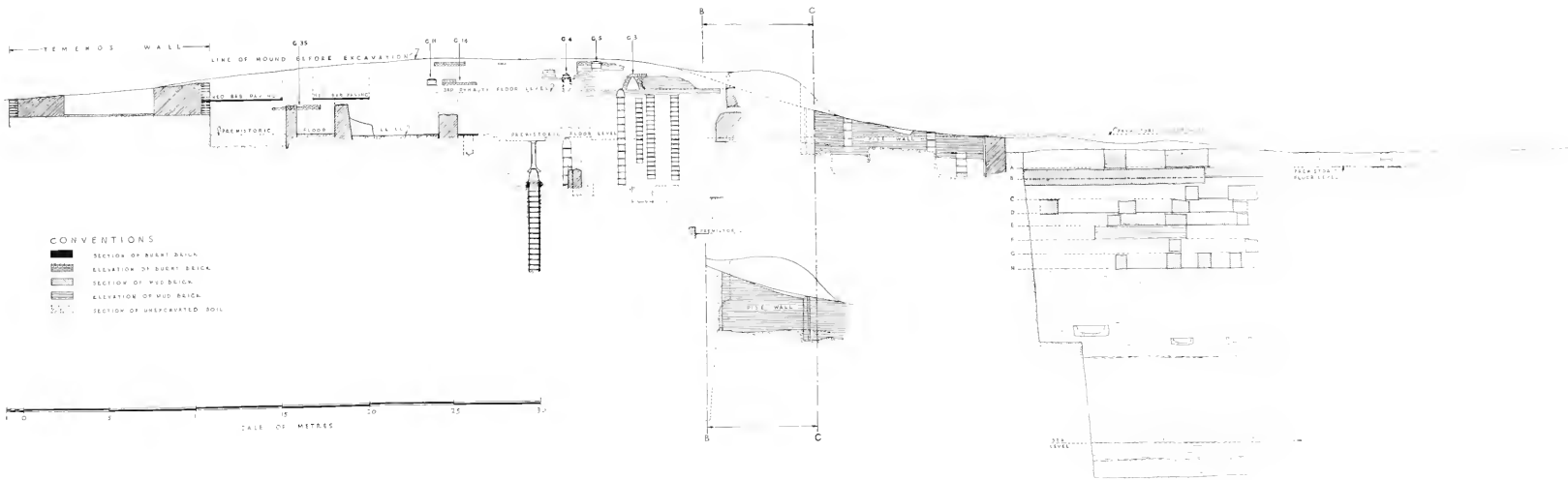

SECTION FROM THE SW TEMENOS WALL OF NEBUCHADNEZZAR
 through the high mound 'EH' and the low-lying ground to the NE of it (the 'Flood Pit')

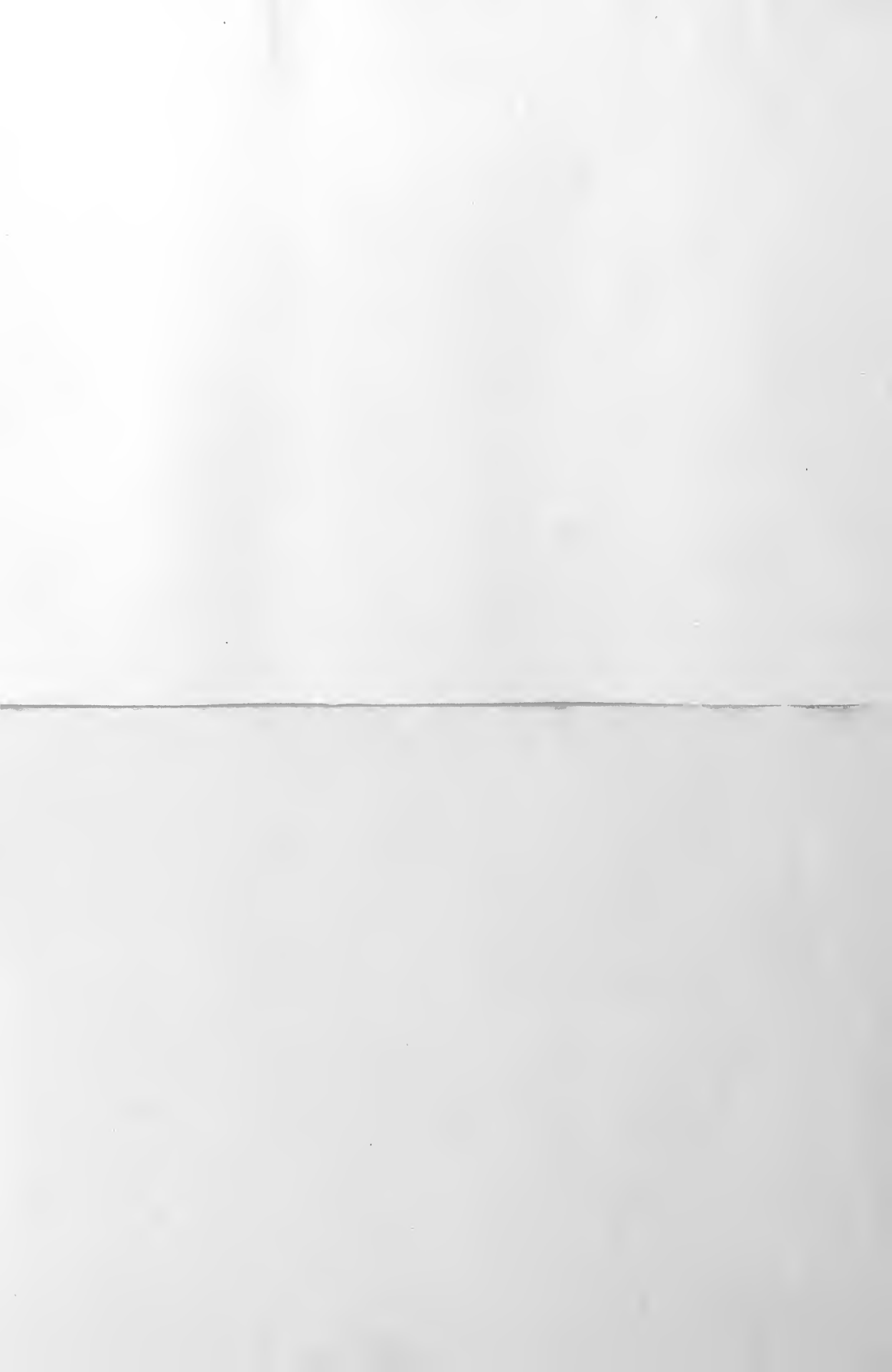

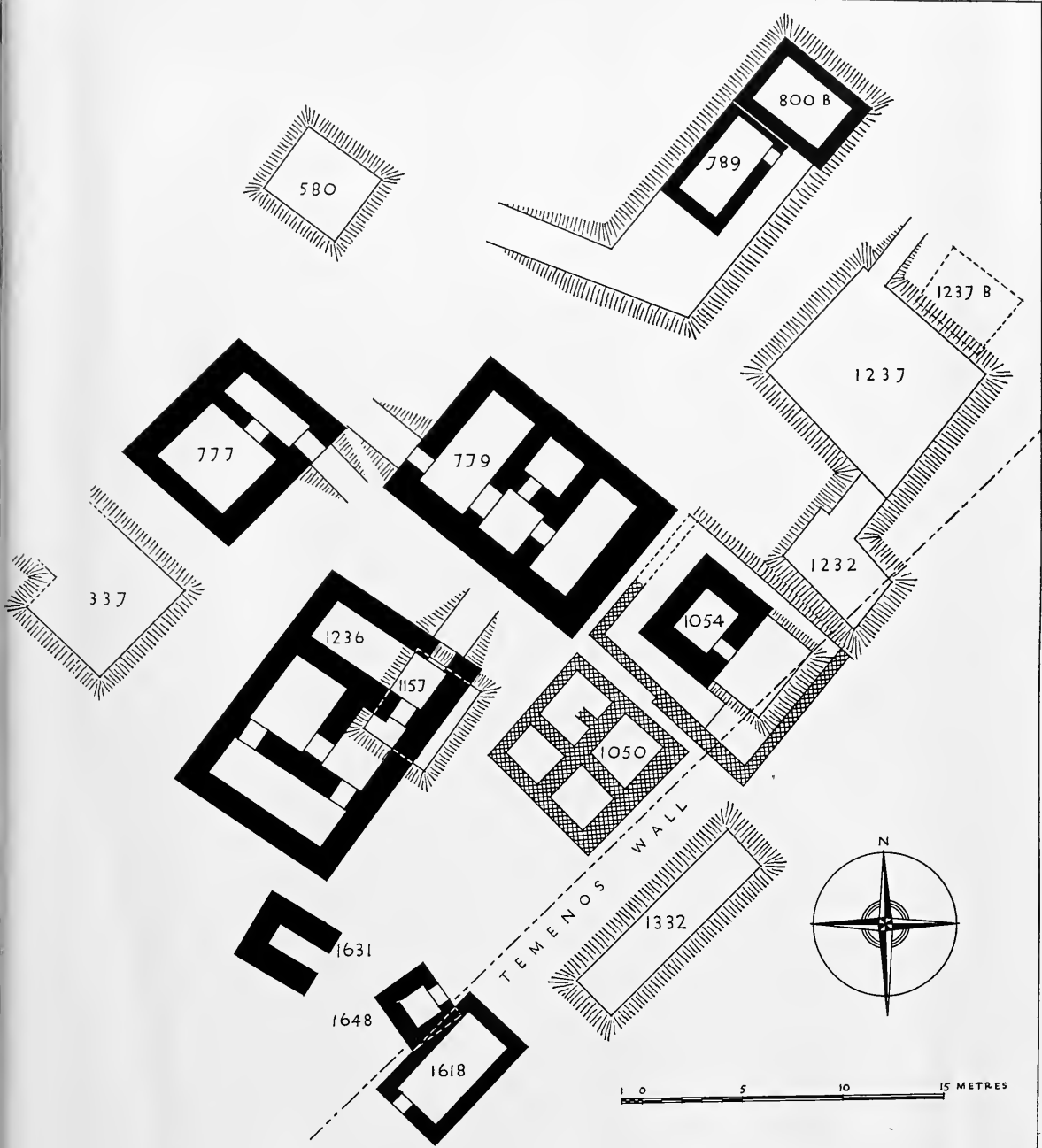

ROYAL TOMBS AND DEATH-PITS



GENERAL PLAN OF THE CEMETERY AREA
CONTAINING THE ROYAL GRAVES

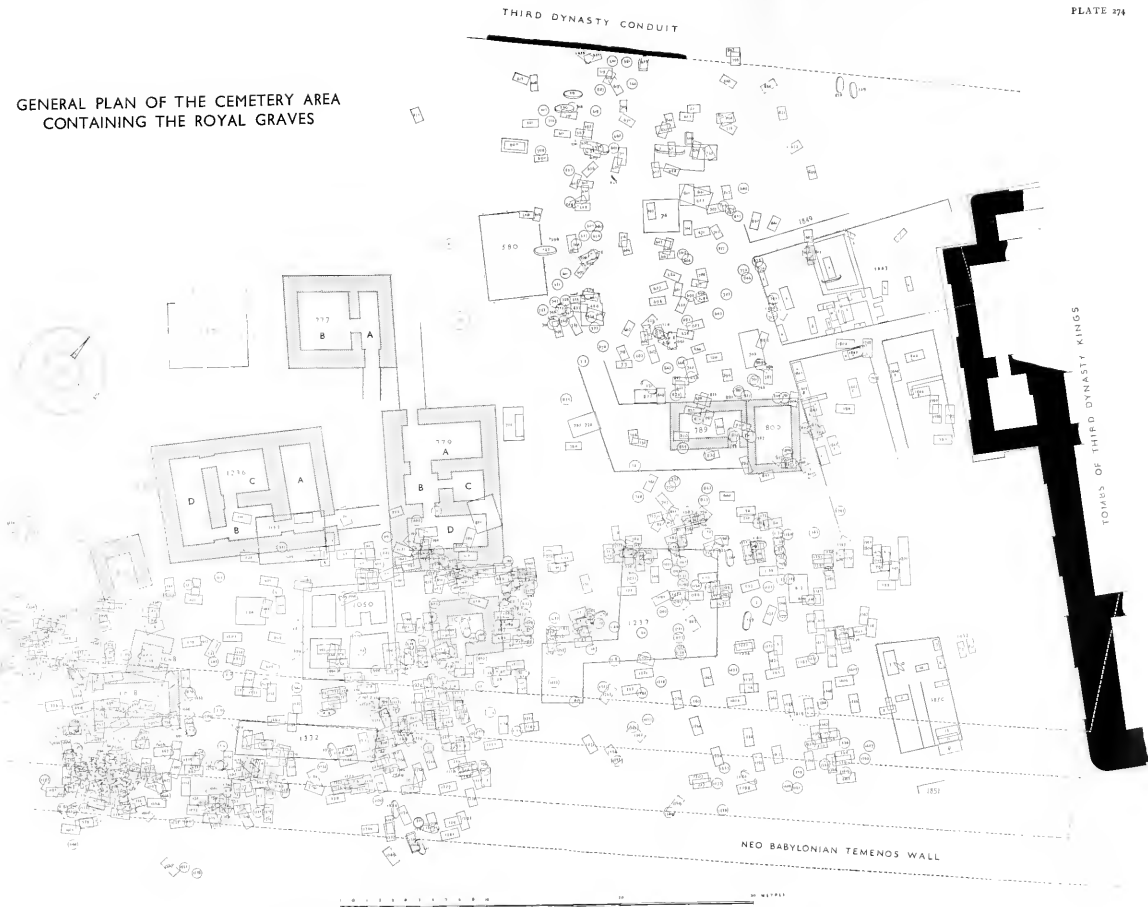

20
871

