

VEHICLES OF THE AIR

A POPULAR EXPOSITION OF
MODERN AERONAUTIC
WITH WORKING DRAWING



VICTOR LOUGHEED

GIFT OF
John S. Prell

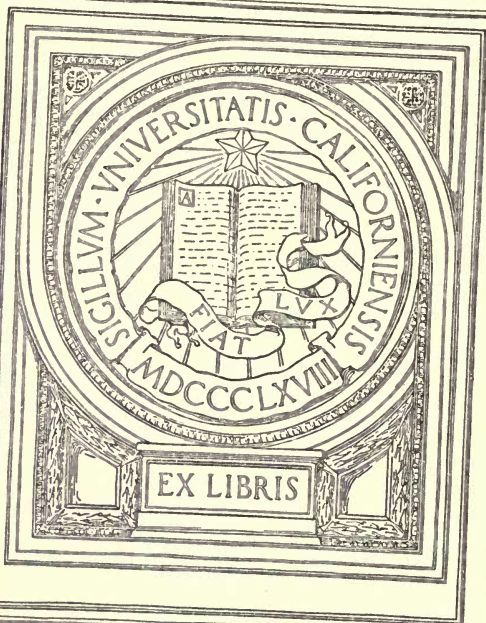

EX LIBRIS

Jan. 19, 1913.

~~200~~
100

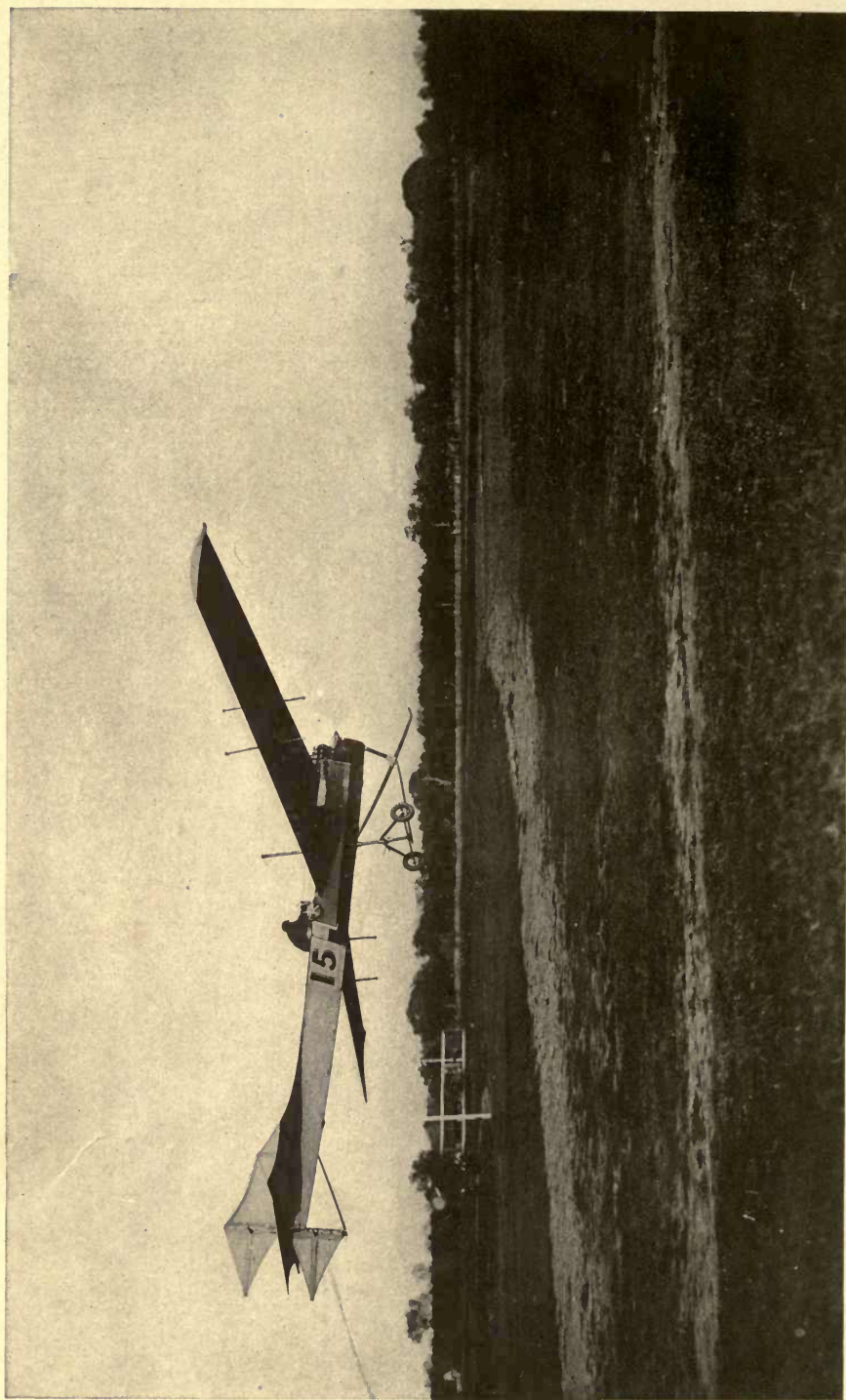

Sands, in an Antoinette Monoplane, coming to ground at Cannes, France.

VEHICLES OF THE AIR

A Popular Exposition of Modern Aeronautics
With Working Drawings

By

VICTOR LOUGHEED

Member of the Aeronautic Society, Founder Member of the Society of Automobile Engineers, Secretary of the American Aeronautical Association, Consulting Engineer of the Aero Club of Illinois, former editor of *Motor*, and author of "Some Trends of Modern Automobile Design."



PUBLISHERS

THE REILLY AND BRITTON CO.

CHICAGO

JOHN S. PRELL

Civil & Mechanical Engineer.

SAN FRANCISCO, CAL.

VEHICLES OF THE AIR

A TABLE OF CONTENTS
WITH WORKING DRAWINGS

VEHICLES OF THE AIR

THIRD EDITION—REVISED AND ENLARGED

ENTERED

Member of the Association of Technical Publishers of the Faculty of Letters
and the Faculty of Science of the University of Cambridge

Entered at Stationers' Hall

Copyright, 1909, by The Reilly and Britton Co.

Copyright, 1910, by The Reilly and Britton Co.

Copyright, 1911, by The Reilly and Britton Co.

All Rights Reserved

PHOTOGRAPHS BY

M. Branger, E. Filiatre, M. Rol, and J. Theodoresco, of Paris. All illustrations herein are fully protected by international copyright. Reproductions positively will not be permitted without due credit, and written authorization from the publishers.

request - Dalton

GFI

Prnell

THE REILLY AND BRITTON CO.

JOHN S. PRELL

100 N. WASHINGTON ST. CHICAGO, ILL.

TL 545
L 7
1911

TABLE OF CONTENTS

INTRODUCTION

<i>Scope and Prophecy</i>	21
<i>Skepticism is Ignorance</i>	23
<i>Three Traversable Media</i>	24
<i>Types of Air Craft</i>	24
<i>Aeroplane Most Successful</i>	26
<i>Speed and Radius</i>	27
<i>Sizes of Aeroplanes</i>	28
<i>First and Operating Costs</i>	28
<i>The Moral Aspect</i>	29
<i>The Physical Hazard</i>	29
<i>Dangers in All Travel</i>	32
<i>Fear a Habit of Mind</i>	33
<i>Commercial Applications</i>	34
<i>Limitations Expected</i>	35
<i>Relation to Warfare</i>	36
<i>An Imaginative Spectacle</i>	37
<i>Travel Over Water</i>	38
<i>Conclusion</i>	39

CHAPTER 1—THE ATMOSPHERE.

<i>Introduction</i>	43
EXTENT.....	43
PROPERTIES AND CHARACTERISTICS.....	45
<i>Weight</i>	45
<i>Composition</i>	46
<i>Color and Transparency</i>	49
AIR AT REST.....	48
<i>Compressibility</i>	49
<i>Effect of Temperature</i>	49
<i>Liquefaction and Solidification</i>	50
AIR IN MOTION.....	50
<i>Inertia</i>	51
<i>Elasticity</i>	52
<i>Viscosity</i>	53
METEOROLOGY.....	53
<i>Temperature</i>	54
<i>Barometric Pressure</i>	56
<i>Humidity</i>	56
<i>Condensation of Moisture</i>	57
<i>Winds</i>	57
<i>Coastal Winds</i>	59
<i>Trade Winds</i>	60
<i>Cyclones, Whirlwinds, and Tornadoes</i>	61
<i>Ascending Components</i>	62
<i>Wind Velocities</i>	62
<i>Atmospheric Electricity</i>	64

CHAPTER 2—LIGHTER-THAN-AIR MACHINES.

<i>Introductory</i>	65
NON-DIRIGIBLE BALLOONS	66
<i>History</i>	66
<i>Spherical Types</i>	75
DIRIGIBLE BALLOONS	76
<i>History</i>	80
<i>Spherical Types</i>	88
<i>Elongated Types</i>	89
Pointed Ends.....	89
Rounded Ends.....	90
Sectional Construction.....	90
The Effect of Size.....	90
<i>Envelope Materials</i>	91
Sheet Metal	92
Silk	93
Cotton	93
Linen	94
Miscellaneous Envelope Materials.....	94
Coating Materials.....	95
<i>Inflation</i>	96
Heated Air	97
Hydrogen	98
Illuminating Gases.....	101
Vacuum	101
Miscellaneous	102
<i>Nettings</i>	103
<i>Car Construction</i>	104
Rattans	105
Wood	106
Miscellaneous	106
<i>Height Control</i>	106
Non-Lifting Balloons.....	107
Escape Valves.....	107
Ballast	109
Compressed Gas.....	109
Drag Ropes.....	110
Open Necks.....	110
Internal Balloons.....	111
Moisture	112
Temperature	112
<i>Steering</i>	113
Lateral Steering	113
Vertical Steering.....	114
<i>Balloon Housing</i>	115
Sheds	115
Landing Pits.....	116

CHAPTER 3—HEAVIER-THAN-AIR MACHINES.

<i>Introductory</i>	117
ORNITHOPTERS	118
<i>History</i>	118
<i>Two Chief Classes</i>	124
<i>Recent Ornithopters</i>	124
<i>Analogies in Nature</i>	124
HELICOPTERS	125
<i>History</i>	126

<i>Recent Experiments</i>	129
<i>Lateral Progression</i>	130
<i>Analogy With Aeroplane</i>	131
AEROPLANES	131
AEROPLANE HISTORY	132
<i>Clement Ader</i>	134
<i>Louis Bleriot</i>	135
<i>Octave Chanute</i>	136
<i>Samuel Pierpont Langley</i>	136
<i>Otto and Gustav Lilienthal</i>	137
<i>John J. Montgomery</i>	138
<i>A. Penaud</i>	146
<i>Percy S. Pilcher</i>	147
<i>Alberto Santos-Dumont</i>	148
<i>F. H. Wenham</i>	149
<i>Wilbur and Orville Wright</i>	149
<i>Voisin Brothers</i>	153
<i>Miscellaneous</i>	153

CHAPTER 4—AEROPLANE DETAILS.

<i>Introductory</i>	158
ANALOGIES IN NATURE	159
<i>Flying Fish</i>	161
<i>Comparison of Flying Animals and Aeroplanes</i>	162
<i>Flying Lizards</i>	163
<i>Flying Squirrels</i>	163
<i>Flying Lemur</i>	163
<i>Flying Frog</i>	164
<i>Soaring Birds</i>	164
<i>Soaring Bats</i>	165
<i>The Pterodactyl</i>	165
<i>Flying Insects</i>	166
MONOPLANES	167
MULTIPLANES	168
<i>Biplanes</i>	169
<i>More Than Two Surfaces</i>	169
FORMS OF SURFACES	169
<i>Flat Sections</i>	171
<i>Curved Sections</i>	172
<i>Arcs of Circles</i>	172
<i>Parabolic Surfaces</i>	173
<i>Force and Motion</i>	193
<i>Momentum</i>	194
<i>Action and Reaction</i>	194
<i>Impact of Elastic Bodies</i>	195
<i>The Impact of Fluids</i>	198
<i>Application</i>	199
<i>Flattened Tips</i>	203
<i>Angles of Chords</i>	204
<i>Wing Outlines</i>	204
<i>Length and Breadth</i>	204
ARRANGEMENTS OF SURFACES	205
<i>Advancing and Following Surfaces</i>	205
<i>Superposed Surfaces</i>	205
<i>Staggered Surfaces</i>	205
<i>Lateral Placings</i>	206
<i>Separated Wings</i>	206

Lateral Curvature.....	207
Dihedral Angles.....	207
VERTICAL SURFACES.....	209
SUSTENTATION OF SURFACES.....	210
<i>Effect of Section</i>	210
<i>Effect of Angle</i>	211
<i>Effect of Speed</i>	211
<i>Effect of Outline</i>	212
<i>Effect of Adjacent Surfaces</i>	212
Center of Pressure.....	213
Head Resistances.....	213
METHODS OF BALANCING.....	215
Lateral Balance.....	215
Vertical Surfaces.....	216
Dihedral Angles.....	216
Wing Warping.....	216
Tilting Wing Tips.....	217
Hinged Wing Tips.....	217
Variable Wing Areas.....	218
Shifting Weight.....	218
Rocking Wings.....	218
Swinging Wings or Wing Tips.....	219
Plural Wing Tips.....	220
Longitudinal Balance.....	220
By Front Rudders.....	220
By Rear Rudders.....	220
Box Tails.....	220
Shifting Weights.....	221
Elevators as Carrying Surfaces.....	221
Automatic Equilibrium.....	221
Arrangement of Surfaces.....	222
Electric Devices.....	222
The Gyroscope.....	222
Compressed Air.....	223
The Pendulum.....	223
STEERING.....	223
<i>Effects of Balancing</i>	223
Vertical Rudders.....	224
Pivoted Rudders.....	224
Flexible Rudders.....	224
Horizontal Rudders.....	225
Twisting Rudders.....	225
CONTROLLING MEANS.....	226
Compound Movements.....	227
Plural Operators.....	227
Wheels.....	228
Levers.....	228
Pedals.....	229
Miscellaneous.....	229
Shoulder Forks.....	229
Body Cradles.....	229
FRAMING.....	230
CHAPTER 5—PROPULSION.	
Introductory.....	231
MISCELLANEOUS PROPELLING DEVICES.....	231
Feathering Paddles.....	
Wave Surfaces.....	233

<i>Reciprocating Wings and Oars</i>	234
SCREW PROPELLERS	236
<i>Some Comparisons</i>	237
<i>Essential Characteristics</i>	238
Effective Surface.....	241
Angles of Blades.....	242
Slip.....	244
<i>Forms of Surfaces</i>	244
Plane Sections.....	245
Parabolic Sections.....	245
Blade Outlines.....	246
<i>Multibladed Propellers</i>	248
<i>Two-Bladed Propellers</i>	249
<i>Propeller Diameters</i>	250
<i>Arrangements of Blades</i>	252
Right-Angled Propeller Blades.....	252
Dihedrally-Aranged Propeller Blades.....	253
<i>Propeller Efficiencies</i>	253
The Effects of Form.....	255
The Effects of Rotational Speed.....	255
The Effects of Vehicle Speed.....	256
The Effects of Skin Friction.....	257
<i>Propeller Placings</i>	258
Single Propellers.....	259
Plural Propellers.....	259
Location of Propeller Thrust.....	264
<i>Propeller Materials</i>	264
Wood.....	265
Steel.....	268
Aluminum Alloys.....	268
Framing and Fabric.....	269
<i>Propeller Hubs</i>	269
A TYPICAL PROPELLER	270

CHAPTER 6—POWER PLANTS.

<i>Introductory</i>	273
GASOLINE ENGINES	277
<i>Multicylinder Designs</i>	277
<i>Cylinder Arrangements</i>	279
Vertical Cylinders.....	279
V-Shaped Engines.....	280
Opposed Cylinders.....	281
Revolving Cylinders.....	282
Miscellaneous Arrangements.....	284
<i>Ignition</i>	284
Make-and Break Ignition.....	284
Jump-Spark Ignition.....	285
Hot-Tube Ignition.....	287
Ignition by Heat of Compression.....	287
Catalytic Ignition.....	288
<i>Cooling</i>	288
Water Cooling.....	289
Air Cooling.....	290
<i>Carburetion</i>	291
Carburetors.....	291
Fuel Pumps.....	294

<i>Muffling</i>	296
<i>Auxiliary Exhausts</i>	297
<i>Flywheels</i>	297
STEAM ENGINES.....	299
<i>Available Types</i>	301
<i>Boilers</i>	301
<i>Burners</i>	303
<i>Fuels</i>	303
Comparison of Fuels.....	304
ELECTRICITY	304
<i>Electric Motors</i>	304
<i>Current Sources</i>	305
Storage Batteries.....	306
Primary Batteries.....	307
Thermopiles	307
MISCELLANEOUS	308
<i>Compressed Air</i>	309
<i>Carbonic Acid</i>	309
<i>Vapor Motors</i>	309
<i>Spring Motors</i>	310
<i>Rocket Schemes</i>	310
TANKS	310
CHAPTER 7—TRANSMISSION ELEMENTS.	
<i>Introductory</i>	313
CHAINS AND SPROCKETS.....	314
<i>Block Chains</i>	316
<i>Roller Chains</i>	317
<i>Miscellaneous</i>	317
Block Chains.....	317
Standard American Roller Chains.....	318
Roller Chains.....	318
Cable Chains.....	319
<i>Reversible Sprockets</i>	319
<i>Missed Teeth</i>	319
SHAFTS AND GEARS.....	320
<i>Shafts</i>	320
<i>Spur Gears</i>	321
<i>Bevel Gears</i>	322
<i>Staggered and Herringbone Teeth</i>	323
BELTS AND PULLEYS.....	324
<i>Pulley Construction</i>	324
<i>Belt Materials</i>	325
CLUTCHES	325
CHAPTER 8—BEARINGS.	
<i>Introductory</i>	327
BALL BEARINGS.....	328
<i>Adjustable Ball Bearings</i>	328
<i>Annular Ball Bearings</i>	330
Annular Ball-Bearing Sizes, Capacities, and Weights.....	337
ROLLER BEARINGS.....	339
<i>Cylindrical Roller Bearings</i>	340
<i>Flexible Roller Bearings</i>	340
<i>Tapered Roller Bearings</i>	341
PLAIN BEARINGS.....	342
<i>Plain Bearing Materials</i>	342
Steel	342

Cast Iron	343
Bronzes	343
Brasses	343
Babbitt	343
Graphite	344
Wood	344
Vulcanized Fiber.....	344
<i>Finish of Plain Bearings</i>	344
Areas	344
Scraping	345
MISCELLANEOUS BEARINGS.....	346

CHAPTER 9—LUBRICATION.

<i>Introductory</i>	347
SPLASH LUBRICATION.....	347
<i>Ring and Chain Oilers</i>	348
GRAVITY LUBRICATION.....	349
<i>Oil Cups</i>	349
<i>Reservoir Systems</i>	350
FORCED LUBRICATION.....	350
<i>Pressure Feed</i>	350
<i>Single Pumps</i>	351
<i>Multiple Pumps</i>	351
<i>Grease Cups</i>	352
LUBRICANTS	352
<i>Mineral Oils</i>	352
Vaseline	353
<i>Vegetable Oils</i>	353
Castor Oil.....	353
Olive Oil.....	353
<i>Animal Oils</i>	354
Sperm Oil.....	354
Tallow	354
<i>Miscellaneous Lubricants</i>	354
Water	354
Kerosene	355

CHAPTER 10—STARTING AND ALIGHTING.

<i>Introductory</i>	356
STARTING DEVICES.....	357
<i>Wheels</i>	358
<i>Rails</i>	358
<i>Floats</i>	359
<i>Runners</i>	360
<i>The Starting Impulse</i>	360
Propeller Thrust.....	361
Dropped Weights.....	362
Winding Drums.....	363
Inclined Surfaces.....	364
<i>Launching Vehicles</i>	365
Automobiles	365
Railway Cars.....	365
Boats	366
<i>Cleared Areas</i>	366
<i>Facing the Wind</i>	367
<i>Launching from Height</i>	368
ALIGHTING GEARS.....	369
<i>Wheels</i>	369

<i>Runners</i>	370
<i>Floats</i>	370
<i>Miscellaneous</i>	371
CHAPTER 11—MATERIALS AND CONSTRUCTION.	
<i>Introductory</i>	372
WOODS	373
<i>Hardwoods</i>	374
Applewood	375
Ash	375
Bamboo	375
Birch	376
Boxwood	376
Elm	376
Hemlock	377
Hickory	377
Holly	378
Mahogany	378
Maple	378
Oak	378
Walnut	378
<i>Softwoods</i>	379
Pines	379
Poplar	379
Spruce	379
Willow	380
<i>Veneers and Bendings</i>	380
METALS	381
<i>Iron</i>	382
<i>Steel</i>	382
Alloy Steels	383
<i>Cast Iron</i>	384
<i>Aluminum Alloys</i>	384
Aerial Metal	384
Aluman	384
Argentium	385
Chromaluminum	385
Magnalium	385
Nickel-Aluminum	385
Partinium	385
Wolframium	385
<i>Brasses and Bronzes</i>	386
Aluminum Bronze	386
Phosphor Bronze	386
<i>Metal Parts</i>	386
CORDAGE AND TEXTILES	387
Cotton	388
Linen	388
Silk	388
PAINTS AND VARNISHES	388
<i>Oils</i>	388
<i>Shellacs</i>	389
<i>Spar Varnishes</i>	389
<i>Aluminum Paint</i>	389
<i>Miscellaneous</i>	389
MISCELLANEOUS	389
Catgut	389
China Grass	390
Hair	390
Rawhide	390

Silk Cord.....	390
Silkworm Gut.....	390
ASSEMBLING MATERIALS AND METHODS.....	390
<i>Nails</i>	390
<i>Glues and Cements</i>	390
<i>Screws</i>	391
<i>Bolts</i>	391
<i>Clips</i>	391
<i>Rivets</i>	391
<i>Electric Welding</i>	391
<i>Autogenous Welding</i>	391
<i>Brazing</i>	391
<i>Soldering</i>	392
<i>Tabular Comparisons of Materials</i>	392
<i>Metals</i>	393
<i>Miscellaneous Materials</i>	393
<i>Transverse Strength of Wood Bars</i>	393
<i>Woods</i>	393

CHAPTER 12—TYPICAL AEROPLANES.

<i>Introductory</i>	394
<i>Antoinette Monoplanes</i>	396
<i>Bleriot Monoplanes</i>	396
<i>Chanute Gliders</i>	398
<i>Cody Biplane</i>	399
<i>Curtiss Biplane</i>	400
<i>Farman Biplane</i>	404
<i>Langley Machine</i>	404
<i>Lilienthal's Machines</i>	404
<i>Maxim Multiplane</i>	405
<i>Montgomery Machine</i>	406
<i>Pilcher Gliders</i>	407
<i>R. E. P. Monoplanes</i>	408
<i>Santos-Dumont Monoplane</i>	408
<i>Voisin Biplane</i>	409
<i>Wright Biplane</i>	409

CHAPTER 13—ACCESSORIES.

<i>Introductory</i>	410
LIGHTING SYSTEMS.....	410
<i>Electric Lighting</i>	411
<i>Advantages of Uniform Motor Speed</i>	411
<i>Arc Lamps</i>	411
<i>Incandescent Lamps</i>	412
<i>The Nernst Lamp</i>	413
<i>Acetylene</i>	413
<i>Storage Tanks</i>	414
<i>Acetylene Generators</i>	414
<i>Acetylene Burners</i>	415
<i>Oxygen Systems</i>	416
<i>With Hydrogen</i>	416
<i>With Gasoline</i>	416
<i>With Acetylene</i>	416
<i>Incandescent Mantles</i>	416
<i>With Gas</i>	417
<i>With Liquid Fuels</i>	417
<i>Oil Lamps</i>	417
<i>Sperm Oil</i>	417
<i>Kerosene</i>	418

<i>Reflectors</i>	418
<i>Arrangement of Lights</i>	419
SPEED AND DISTANCE MEASUREMENTS	420
<i>Anemometers</i>	420
<i>Miscellaneous</i>	421
COMPASS	422
<i>Fixed-Dial Compasses</i>	423
<i>Floating-Dial Compasses</i>	423
BAROMETERS	424
<i>Mercurial Barometers</i>	424
<i>Aneroid Barometers</i>	424
WIND VANES	425
MISCELLANEOUS INSTRUMENTS	425

CHAPTER 14—MISCELLANY.

<i>Introductory</i>	427
APPLICATIONS	428
<i>Warfare</i>	429
<i>Sport</i>	432
<i>Mail and Express</i>	433
<i>News Service</i>	434
<i>Effects of Low Cost and Maintenance</i>	434
<i>General Effects</i>	435
RADII OF ACTION	436
<i>Influence of Wind</i>	437
DEMOUNTABILITY	437
PASSENGER ACCOMMODATION	439
<i>Seats</i>	440
<i>Housing</i>	440
<i>Upholstery</i>	440
<i>Pneumatic Cushions</i>	440
<i>Heating</i>	441
<i>By the Exhaust</i>	441
PARACHUTES	442
DESIGNING	443
TESTING AND LEARNING	444
<i>Learning from Teacher</i>	444
<i>Practice Close to the Surface</i>	444
<i>Practice over Water</i>	445
<i>Maintaining Headway</i>	445
<i>Landing</i>	445
AERIAL NAVIGATION	446
<i>Flying High</i>	446
<i>Steadier Air</i>	446
<i>Choice of Landing</i>	447
<i>Flying Low</i>	447
<i>Falling</i>	448
<i>Striking Obstacles</i>	448
<i>Vortices and Currents</i>	448
TERRESTRIAL ADJUNCTS	449
<i>Signals</i>	449
<i>Fog Horns and Whistles</i>	450
PATENTS	451
GLOSSARY OF AERONAUTICAL TERMS	464

CHAPTER 15—FLIGHT RECORDS.

<i>Introductory</i>	473
TABULAR HISTORY OF FLIGHTS	478

INDEX

<i>Commences on Page</i>	492
--------------------------------	-----

LIST OF ILLUSTRATIONS

FIGURE.	PAGE.
Sands, in an Antoinette Monoplane, Coming to Ground at Cannes, France	Frontispiece
Count de Lambert in Wright biplane at Juvisy, France.....	452
1.—Bleriot Flying from Etampes to Orleans.....	43
2.—View in Paris Aeronautical Exhibition—October, 1909.....	65
3.—Layout of Gores for Spherical Balloon.....	76
4.—Giffard's Dirigible Balloon.....	80
5.—Tissandier's Dirigible Balloon.....	81
6.—Renard's and Krebs' Dirigible Balloon.....	82
7.—Texture of Modern Balloon Fabrics.....	85
8.—Modern Spherical Balloon.....	90
9.—Shuttles for Knotting Balloon Nettings, and Some Typical Knots..	104
10.—Balloon Valve	108
11.—Car of Modern Spherical Balloon.....	90
12.—Curious Drag Rope of Wellman Dirigible.....	94
13.—Internal Balloon	111
14.—Balloon House for Dirigible "Russie".....	94
15.—Portable Balloon House Used by the French Army.....	96
16.—Balloon Houses Nearing Completion.....	96
17.—Rigid Construction of Zeppelin Dirigible.....	100
18.—Dirigible Balloon, "Ville de Nancy".....	104
19.—Side View of Nacelle of Wellman Dirigible.....	108
20.—Front view of Nacelle of Wellman Dirigible.....	108
21.—Mailcot Semi-Rigid Dirigible Balloon.....	104
22.—Nacelle of the French Dirigible, "Zodiac III".....	104
23.—Count de Lambert Piloting Wright Biplane.....	117
24.—Degen's Orthogonal Flier	120
25.—Trouve's Flapping Flier.....	121
26.—Engine and Wing Mechanism of Hargrave Model No. 18.....	122
27.—Collomb Ornithopter	126
28.—Toy Helicopter	127
29.—Toy Helicopter	128
30.—Toy Helicopter	128
31.—Bertin Helicopter	126
32.—Cornu Helicopter	140
33.—Bertin Helicopter-Aeroplane	140
34.—Box Kite	133
35.—Montgomery Aeroplanes of 1884-5, with Hinged Allerons in Wings.	140
36.—Le Bris' Glider	155
37.—Moy's Aerial Steamer	158
38.—Flying Fish	161
39.—Flying Frog	164
40.—Comparison of Pterodactyl and Condor.....	166
41.—Wing-case Insect	166
42.—Pressure on Vertical and Inclined Surfaces.....	171
43.—Plane and Arched Surfaces without Angle of Incidence.....	172
44 to 67.—Geometrical and other Drawings Explaining the Formation and Action of Wing Surfaces.....	176-199
68.—Staggered Biplane	205
69.—Goupy Biplane	158
70.—Langley's 25-Pound Double Monoplane.....	208
71.—Internal Framing of Antoinette Monoplane Wing.....	158
72.—Framing of Antoinette Wing Inverted.....	158
73.—Framing of Bleriot Monoplane Wing.....	164
74.—Inverted Upper Wing Frame of Wright Biplane.....	164
75.—Assembling Wright Wing Frames.....	170
76.—Alleron Control of Lateral Balance in Antoinette Monoplane.....	170
77.—Alleron Control of Bleriot Monoplane VIII.....	170
78.—Lejeune Biplane with Double Alleron Control.....	174
79.—Front View of Pischoff and Koechlin Biplane.....	174
80.—Side View of Pischoff and Koechlin Biplane.....	174

FIGURE.	PAGE.
81.—Alleron Control of Farman Biplane.....	174
82.—Sliding Wing Ends.....	218
83.—Swinging Wing Ends.....	219
84.—Wright Flexible Elevator or Rudder.....	225
85.—Rear Controls of Antoinette Monoplane.....	226
86.—Double Control from Single Wheel.....	226
87.—Shoulder-Fork Control.....	228
88.—Frame of New Voisin Biplane.....	230
89.—Fuselage of Bolotoff Monoplane.....	230
90.—Feathering-Paddle Flying Machine.....	232
91.—Partially-Housed Paddle Wheel.....	233
92.—Wave Surface.....	233
93.—Helices of Propeller Travel.....	239
94.—Circles of Propeller Travel.....	239
95.—Diagram of Propeller Pitch.....	240
96.—Angle of Propeller Blade to Angle of Travel.....	242
97.—Advancing and Following Surfaces.....	248
98.—Three-Bladed Propeller.....	251
99.—Four-Bladed Propeller.....	251
100.—Chauviere Walnut Propeller.....	254
101.—Propeller, Engine, and Wing Frame of Antoinette Monoplane.....	254
102.—Engine and Propeller of Santos-Dumont Monoplane.....	254
103.—Wooden Propeller of Clement Dirigible Balloon.....	240
104.—All-Metal Propeller Applied to Dirigible Balloon.....	240
105.—Straight, Dihedral, and Curved Propellers.....	252
106.—Effect of Gyroscopic Action of Single Propeller on Steering.....	263
107.—Twin Wood Propellers on Single Shaft.....	264
108.—Working Drawings of a Wooden Propeller.....	266
109.—Templets for Securing a Desired Form in a Wooden Propeller.....	271
110.—Four Cylinder Motor of Wright Biplane.....	273
111.—Pump-Fed Antoinette Engine.....	273
112.—Three-Cylinder, 22-Horsepower Anzani Engine.....	276
113.—Four-Cylinder—"Double-Twin"—Anzani Motor.....	278
114.—Renault Eight-Cylinder V-Shaped Motor.....	278
115.—Flat and Panhard Aeronautical Motors.....	280
116.—Darracq and Duthell-Chalmers Aeronautical Motors.....	280
117.—Diagram of Revolving-Cylinder Motor.....	283
118.—Gnome Revolving-Cylinder Motor.....	284
119.—Ten-Cylinder Motor with Concentric Exhaust and Inlet Valves.....	276
120.—Magnetic Plug.....	285
121.—Make-and-Break Ignition.....	285
122.—Mechanical-Break Jump-Spark Ignition System.....	286
123.—Jump-Spark Ignition.....	286
124.—Hot-Tube Ignition.....	287
125.—Fuel-Injection Aeronautical Engine.....	290
126.—Carbureter.....	292
127.—Mietz and Weiss Fuel Pump.....	295
128.—Silencer.....	296
129.—Muffler.....	296
130.—Steam Engine for Aeronautical Use.....	300
131.—Flue Boiler.....	302
132.—Water-Tube Boiler for Aeronautical Use.....	300
133.—Aeroplane Power-Transmission System.....	313
134.—Aeroplane Power-Transmission System.....	313
135.—Aeroplane Power-Transmission System.....	313
136.—Aeroplane Power-Transmission System.....	313
137.—Block Chain.....	316
138.—Roller Chain.....	317
139.—Chain Transmission of Wright Biplane.....	313
140.—Chain Transmission in Hydroplane, Driven by Aerial Propellers.....	313
141.—Belt Transmission in Recent Santos-Dumont Monoplane.....	316
142.—Voisin Biplane Modified into a Triplane.....	327
143.—Henry Farman's Biplane in Flight.....	327
144.—Adjustable Ball Bearing.....	329
145.—Annular Ball Bearing.....	330
146.—Full Type Annular Ball Bearing.....	332
147.—Annular Ball Bearing.....	332
148.—Annular Ball Bearing.....	332

LIST OF ILLUSTRATIONS

19

FIGURE.	PAGE.
149.—Annular Ball Bearing Subjected to Thrust.....	333
150.—Ball Thrust Bearing.....	334
151.—Resultants of Load on Ball Bearing.....	335
152.—Cylindrical Roller Bearing.....	340
153.—Flexible Roller Bearing.....	341
154.—Projected Area of Plain Bearing.....	345
155.—Adjustment of Plain Bearing.....	346
156.—Cone bearing.....	346
157.—Bleriot XI. in Flight.....	347
158.—Bleriot XII. in Flight.....	347
159.—Ring Oiler on Crankshaft.....	349
160.—Force-Feed Lubricator.....	351
161.—Wright Biplane Starting and in Flight.....	348
162.—Koechlin Monoplane in Flight.....	350
163.—Wright Machine on Starting Rail.....	350
164.—Bleriot Alighting Gear.....	350
165.—Wright Starting System.....	358
166.—Wright Machine and Starting Derrick.....	360
167.—Starting by Rope Attached to Stake and Wound in on Drum.....	364
168.—Rougler's Voisin Rising from Starting Ground.....	360
169.—Bleriot Starting Device.....	368
170.—Typical Alighting Gear.....	368
171.—Details of Bleriot Monoplane.....	370
172.—Alighting Gear of Paulhan's Voisin.....	370
173.—Elevating Montgomery Aeroplane with a Balloon, in California, in 1905.....	372
174.—Alighting Gear of Farman Machine.....	374
175.—Boat-Like Body of Antoinette Monoplane.....	374
176.—Alighting Gear of Antoinette Monoplane.....	374
177.—Built-Up Bamboo Spar.....	376
178.—Sections of Wooden Spars.....	380
179.—Built-Up Hollow Wooden Spar.....	381
180.—Built-Up Bamboo, Hickory, and Rawhide Wing Bar.....	381
181.—Methods of Fastening Wire Ends.....	386
182.—Strut Sockets and Turnbuckles.....	387
183.—Wire Tightener.....	387
184.—Texture of Modern Aeroplane Fabrics.....	372
185.—Scale Drawings of Wright Biplane.....	392
186.—Side View of Wright Machine.....	394
187.—Three-Quarters View of Wright Machine.....	394
188.—Rear View of Wright Machine.....	398
189.—Paul Tissandier Seated in Wright Biplane.....	400
190.—Count de Lambert in Wright Biplane.....	400
191.—Wilbur Wright Instructing a Pupil.....	400
192.—Details of Wright Strut Connections.....	402
193.—Side View of Wright Runner Construction.....	402
194.—Wright Runner and Rib Details.....	402
195.—Rudder Frame of Wright Machine.....	404
196.—Elevator Frame of Wright Machine.....	404
197.—Scale Drawings of Bleriot Monoplane Number XI.....	406
198.—Bleriot Monoplane Number XII.....	408
199.—Bleriot Monoplane Number XI.....	408
200.—Front View of Bleriot XI.....	408
201.—Three-Quarters View of Bleriot XI.....	408
202.—Scale Drawings of Cody Biplane.....	412
203.—Latest Model of Voisin Biplane.....	414
204.—Three-Quarters Rear View of Voisin Biplane.....	414
205.—Three-Quarters Front View of Voisin Biplane.....	414
206.—Scale Drawings of Farman Biplane.....	416
207.—Side View of Farman Biplane.....	418
208.—View of London-Manchester Farman Biplane.....	418
209.—Maurice Farman's Biplane.....	420
210.—Front View of Maurice Farman's Biplane.....	420
211.—Farman's Modified Voisin.....	420
212.—Scale Drawings of Antoinette Monoplane.....	397
213.—Three-Quarters View of Antoinette III.....	424
214.—Rear View of Antoinette V.....	424
215.—Front View of Antoinette VII.....	424
216.—Rear View of Antoinette VII.....	426
217.—Side View of Santos-Dumont's Belt-Driven Monoplane.....	426

FIGURE.	PAGE.
218.—Front View of Santos-Dumont's Belt-Driven Monoplane.....	426
219.—Side View of Santos-Dumont's Demoiselle.....	424
220.—Front View of Santos-Dumont's Demoiselle.....	426
221.—Scale Drawings of Santos-Dumont's Monoplane.....	428
222.—Side View of R. E. P. Monoplane.....	430
223.—Three-Quarters View of R. E. P. Monoplane.....	430
224.—Captain Ferber's Dihedral Biplane.....	430
225.—Scale Drawings of Montgomery Glider.....	432
226.—Side View of Montgomery Monoplane Glider.....	434
227.—Side View of Small Power Propelled Montgomery Double Monoplane	434
228.—Scale Drawings of Curtiss Biplane.....	401
229.—Side View of Latest Curtiss Biplane.....	436
230.—Early Lillenthal Monoplane Glider.....	405
231.—Lillenthal Monoplane Glider.....	405
232.—Lillenthal's Biplane.....	405
233.—Pilcher Glider.....	407
234.—Pilcher Glider.....	408
235.—Maxim Multiplane.....	406
236.—Maxim Multiplane.....	406
237.—Chanute Biplane Glider.....	398
238.—Santos-Dumont's Demoiselle in Flight.....	410
239.—Paulhan's Voisin in the Douai-to-Arras Flight.....	410
240.—Suggested Nernst Lamp.....	413
241.—Lens Mirror.....	418
242.—Locomotive Headlight.....	419
243.—Anemometer Speed and Distance Recorder.....	421
244.—Universal Level.....	426
245.—Side View of Bleriot XI, with Wings Tied on Frame.....	427
246.—Front View of Bleriot XI, Showing Demountable Wings.....	427
247.—Assembling Bleriot XI.....	427
248.—Wicker Chair and Foot Control of Ailerons in Farman Biplane.....	440
249.—Cockpit of Bleriot Monoplane Number XI.....	440
250.—Seating Arrangement and Control System of Antoinette Monoplane	448
251.—Sling Seat of Captain Ferber's Biplane.....	448
252.—Cockpit and General Details of R. E. P. Monoplane.....	450
253.—Latham's Antoinette Monoplane in the English Channel.....	450
254.—General View of Paris Aeronautical Salon.....	452
255.—Suggested Use of Exhaust Gases to Heat Foot Warmer.....	441
256.—Parachute.....	442
257.—Effect of Height Upon Choice of Landing.....	447
258.—United States Weather Signals.....	450
259.—Wright Patent Drawings.....	453
260.—Montgomery Patent Drawings.....	459
261.—Chanute Patent Drawing.....	462
262.—Mouillard Patent Drawing.....	463
263.—Lillenthal Patent Drawing.....	464
264.—Diagrammatic Comparisons of Modern Aeroplanes.....	473
265.—Flights over English Channel.....	474
266.—Farman Flights, Chalons to Rheims, and Chalons to Sulpes.....	474
267.—Count de Lambert's Flight over Paris.....	474
268.—Map Showing Principal Zeppelin Flights.....	475
269.—Flight of Paulhan and Grahame-White, London to Manchester.....	476
270.—Flight of Curtiss from Albany to New York City.....	476

*"For centuries we stood upon the edge
Of space and yearned, while sparrows from the hedge
Took flight and taunted us. 'That I had wings!'
'Mid stormy music, thus the Psalmist sings,
'Then would I fly away and be at rest.'
And lo, the wings are ours, a gift, the best
The genius of our race has forged. * * **

*" * * * What narrow space
Holds man to-day apart from brother man,
A range of rock, a river or a span
Of channel; and our wings shall overleap
These dwarfish landmarks. * * *"*

CHARLTON LAWRENCE EDHOLM.

INTRODUCTION

To the preparation of this work, the author has been influenced largely by the lack of any concrete and popular treatise on aerial navigation.

SCOPE AND PROPHECY

With the object of remedying this condition in at least some degree it has been sought to produce an adequate, up-to-date, and at the same time a comprehensive presentation of what is fast becoming one of the most important and alluring fields of modern engineering. In the accomplishment of this purpose it has seemed desirable to plan a volume that should appeal to general curiosity as well as to particular interest. This is because the subject is so new that few can lay any claim to its mastery, though thousands are commencing its study.

These conceptions of the need, and of the sort of interest to be met by a book of this character, have dictated the inclusion not only of timely and authoritative data concerning contemporary successes, but also of some material that is chiefly historical—often the history of now discredited mechanisms—as a help in easily and clearly conveying to the casual reader a logical idea of just what progress has been made and is making in the modern science of aeronautics. It

even has appeared reasonable to venture occasional suggestions of the future—forecasts intended simply to stimulate still doubtful imaginations rather than to invalidate themselves by too-complicated or far-fetched premises. Yet in such prophecies it will be readily appreciated by the technically versed that the prophet is sufficiently safe if he don his robe without too reckless a disregard of his limitations, and confine himself to impressing upon the general attention only such facts as are already evident and obvious to the few specialists who are closely in touch with their subject.

Necessarily some portion of the matter herein presented is in a way the product of compilation. It being the province of the writer at a task of this sort to record rather than to create, it is not to be expected that much more can be accomplished than a discriminating and consistent addition of new material to old, with the two arranged and related in an orderly and informing manner. No more than this has been attempted; if no less has been accomplished the author will feel well satisfied.

The publishers join with the author in the hope that this book may help to stimulate the English-speaking races into some parallel with foreign enthusiasm in aeronautics. For it seems as true as it is regrettable that the nations that developed the Wright brothers, Montgomery, Chanute, Langley, Herring, Pilcher, Stringfellow, Wenham, Hargrave, Henson, Maxim, McCurdy, Curtiss, and others, and which once were found always in the van of the world's progress in science and invention, are replacing their one-time zeal for promising innovations and scorn of hampering precedents with an imitative and trailing commercialism, of which there already has been at least one

other sufficient example. Certainly it is an inescapable fact that the less tradition-trammeled engineers of continental Europe are the first to perceive the beginnings of the practical and commercial era in aeronautics, just as they were the first to perceive it in the case of the automobile. And equally is it a fact that the United States and the British governments, and American and English capitalists, continue conspicuously tardy in their recognition of the newest and least-limited advance in the history of transportation.

Nothing but the utmost blindness to existing achievements can continue to belittle what it cannot comprehend. Aerial navigation today is no more a joke than was the railway eighty years ago, or the steamship seventy years ago, or the automobile ten years ago. On the contrary, it is already the basis of a vast and progressing industry, founding itself surely on the most advanced discoveries of exact science and the finest deductions of trained minds, and possessed of a future that in its sociological as well as in its engineering aspects sooner or later must stir the imaginations of the dullest skeptics. Inevitably it is a matter of perhaps no more than a few months—certainly of no more than a few years—after this is written when in every country of the world aerial vehicles will enter upon an epoch of wide development and application, the far-reaching reactions of which are certain to carry significances of the profoundest import to every phase of civilization and every activity of the race.

Man's movements about the planet he inhabits are

restricted to a maximum of the three traversable media with which he can come in physical contact. He can

THREE TRAVERSABLE MEDIA travel by land, by water—and by air. Of the difficulties of these, he first overcame the simplest, as was to have been expected; he next fell to devising one kind and another of water craft, and progressed to navigation of the seas; and now, after centuries of ineffective struggle, he is beginning to apply the hard-won lessons of his slowly-accumulated knowledge to the conquest of the air. Of the three media, the air alone exists over the earth's entire surface, thus demanding for its utilization neither specially-constructed highways nor restriction of journeys such as limit or make costly all efficient transportation on land and water. And, more than this, as there are unknowable forces greater than the mere opinions and activities of men so is it only consistent with experience of human progress and observation of the eternal logic of things to recognize that sooner or later mankind *must* conquer this last highway of the world, thus finally asserting the dominion over all things terrestrial that is declared his right by the scriptures.

Concerning the types of machines that will survive, as most successfully applicable to practical and commercial navigation of the air, present knowledge is distinctly informing. It seems rather clearly indicated, for example, that the "lighter-than-air" type, the balloon, can have little future beyond such as is too often founded upon the activities of ignorant inventors or unscrupulous promoters, or upon the thrills it undoubtedly affords as a Gargantuan spectacle. As is hereinafter suggested the balloon is an evasion rather

**TYPES OF
AIR CRAFT**

than a solution of the real problems of aerial navigation. It floats in the air rather than navigates it, wherefore it is no more a flying machine than a cork in the sea is an ocean liner.*

The helicopter is the type of "heavier-than-air" machine designed to ascend by the action of one or more lifting propellers, rotating on vertical axes. The type must for the time be dismissed as without present status to condemn or approve it. It is enough to say that more than one engineer of unquestioned eminence has faith in it, while there are others of equal standing who as positively disapprove.

The term ornithopter is given to any type of heavier-than-air machine in which there is attempted imitation of nature's wing motions. The matter of its merits comes down chiefly to the simple question of whether or not a reciprocating-wing system can be made superior in reliability and efficiency to the rotating-wing system that constitutes a propeller. Probably no engineer of practical abilities will contend that it can. It is a common argument that birds, which may be considered the flying machines par excellence, fly on this plan. Admittedly true, but it is equally true that most animals walk on legs and most fishes swim with tails and fins, despite which man finds that with wheels and screw propellers he can secure results vastly superior to any that are to be found in attempts to copy nature's mechanisms more closely. It is a point deserving of regard in

*It being a fact, however, that the dirigible balloon exists, and that its problems are enlisting the activities of able engineers and powerful governments, for these reasons it will herein in all fairness be accorded such attention as seems demanded by its present prominence rather than by its future prospects.

this connection that the real reason the continuous rotating mechanism is unknown in the animal economy may be the most excellent one that it is not available. A wheel or any similar continuous-rotating element in a machine involves a complete separation of parts, mere contact or juxtaposition being substituted for the complete structural continuity that is rendered imperative in the natural machine by nature's self-contained processes of manufacture, growth, and repair—processes with which man's mechanisms are not handicapped, however imperfect they may be in other respects.

The aeroplane is far and away the most promising of the several types of machines in so far as any present vision can discern. This type of air craft is sustained by the reactions of the air rotations and streams under and adjacent to its inclined curved surfaces, and in nature finds its analogy in the soaring bird, and particularly in certain insects. Ordinarily, to fly, an aeroplane must keep moving, wherefore it must attain lateral speed before it can rise, and must retard to a stop in alighting. Without exception all the successes recently achieved in the United States and abroad have been with curved-wing* aeroplanes.

The questions of speed and flying radius are still some way from any sort of settlement. Certainly the speeds ultimately attained will be very high, but, what is more to the point, they will be easily maintained. In this regard aerial navigation is comparable with

*The modern substitution of curved surfaces for the flat ones of earlier experiments has made the term "aeroplane" a misnomer, but it seems nevertheless to have fixed itself ineradicably upon the language, and so may as well be accepted.

travel on water rather than with travel on land, maximum speeds being also average speeds in the case of the steamship, though this is not the case with land locomotion. In addition to its other advantages, high speed of aerial travel may prove the soundest engineering because it admits of sustaining the heaviest loads upon the smallest surfaces. Another and imperative reason for speed will be to overcome adverse winds. To progress against wind, speed higher than the highest wind in which flying is to be attempted may be required. The limit of wind velocity with which it may prove possible to battle will be determined mainly by conditions of starting and landing.

As for the possible radii or action—the maximum distances of travel without return to a base or descent to the earth for additional supplies of fuels, lubricants, etc.—it is evident at the outset that the greater the radius the greater the utility. Indeed, the ability to combat long-continued adverse winds, application to polar and other exploration, transoceanic travel, and sustained rapid transit overland may hinge directly upon capacity to accomplish great distances on minimums of supplies and fuel.

The sizes of the machines that will be built is another matter for the future to determine. It being a law of geometry that the areas of structures increase with the squares of their linear dimensions, while bulks and weights increase with the cubes, it is evident that at some point the gain of the weights over the areas will impose a limit that cannot be passed. Against this, however, is the likelihood that there may not be much use for large craft. Traffic experts agree

that the secret of all rapid transit is the maintenance of speed, it being the slowings down and the stops that chiefly account for the slow average speeds on land despite the wonderful spurts that have been made by land vehicles for short distances. Most evidently, the existence of the expensive large-unit vehicle on land is mainly due to the necessity for highly-specialized, prepared highways, while on water it has been found an essential means to high speeds and maximum safety. In the air conditions will be different. Here the inexpensive and ideal small-unit vehicle, suggested in some degree by the automobile, and likewise emancipating its user from other persons' routes, stops, and time schedules, will find an unlimited field for development. Moreover, such development will progress under the stimulus of lower first and maintenance costs than apply to any other system of travel.

Flying machines will be inexpensive to build because their construction calls for little use of complex forms in resistant metals. Wood, wire, and fabric of common qualities and at low cost are almost the extent of what is necessary, barring the question of motors, which will be cheaply manufactured in quantities, to standardized designs. And even more vital than mere low cost of manufacture will be the fact that manufacture will not require the facilities of costly factories, but can be undertaken by any one possessed of the requisite data and an ordinary sort of carpentering ability.

That flying machines will be inexpensive to operate must reasonably follow from the small power needed for their propulsion and from the fact that they have

no working parts in constant destructive contact with a roadway. Indeed, the transition from the expedient of confining air in automobile tires to the utilization of the unconfined air of the atmosphere as a vehicle support is rather definitely an advance from a lower to a higher order of engineering.

Nor are these questions of cost in any sense the least important factors in the future of aerial navigation. Modern engineering abounds in examples of things that are possible but not profitable. Indeed, it is just

**THE MORAL
ASPECT**

this point, that limited utilities do not warrant unlimited expenditures, that so utterly condemns the dirigible balloon. With flying machines, sufficing for the safe, inexpensive, and rapid conveyance of one or two persons, cheaper to build than a modern motorcycle, there enter prospects that must ultimately loom larger on the horizon of transportation and the whole structure of modern society than even so great a prospect as the actual accomplishment of aerial navigation itself. Laws, customs, and conventions must fall in the tremendous readjustments that will ensue. Many forms of social trespass will have to be fought by removal of incentives rather than by attempts at punishment, and there will be discovered innumerable outlets for various movements for race improvement, which the iron inflexibility of present-day environment keeps suppressed and silent.

Questions of safety are ever uppermost in most persons' contemplations of aerial travel. To the average individual let there be said

**THE PHYSICAL
HAZARD**

flying machine and at once his brain must visualize some horrifying conception of an unstable craft of vague outlines and

terrible hazards, precariously poised in the cloudland at an illimitable height above terra firma. How distinctly such ideas are at variance with the facts has been shown by the Wright brothers, Farman, Bleriot, and others, in flying for mile after mile only four or five feet from the ground.*

People are prone to appraise casualty by its horror rather than by its statistics, and the thought of one individual tumbling from the skies grips harder on the popular imagination than the slaughter of a few scores in a railway accident or the drowning of a few hundreds in a shipwreck. As a matter of fact, there are many more factors of safety in present and prospective aerial travel than at first appear, even to the well-informed. Besides the proved practicability of close-to-the-ground flight, there is in the case of the aeroplane the complete stability of the type as a glider.† This means that the immediate safety at any moment is not contingent upon the operation of a more-or-less complicated motor, the continued functioning of which is dependent upon the unflinching operation of an interconnected aggregation of parts rapidly revolving or reciprocating under heavy stresses. On the contrary, a motor is necessary, if

* In teaching Captain Lucas Gerardville of the French army to operate the Wright flyer, Wilbur Wright required the control of the levers to be returned to him whenever the machine was steered lower than two meters (6½ feet) or higher than four meters (13 feet) from the ground, thus indicating that he considered inability to keep within this zone, even for a beginner, as definitely incompetent driving as would be steering out of the road with an automobile. Such close-to-the-ground flight is particularly well shown in the photographs reproduced in Figure 161.

† The Wright machine was first developed as a glider without a motor, and in its later motor-propelled models has been on more than

at all, only to maintain continued upward or horizontal travel, the ability to soar reliably at a flat angle down a slant of air being contingent only upon the continued structural integrity of non-moving elements, or at worst, of elements readily made very strong or even provided in duplicate, and demanding only moderate and occasional control adjustment against very light stresses. As a consequence, the only risk likely to continue ever-present is that of such derangement or the encountering of such adverse weather conditions as may compel landing upon unfavorable areas without immediate but with the prospect of ultimate disaster. Thus, to be compelled by engine failure or adverse weather to descend in a desert or forest, or on rough mountains, would result in a situation fairly comparable to that of a wrecked vessel, or of a derailed train, or of a ditched automobile, rather than in one ascribable to any undue and inherent hazard pertaining to the new conveyance regardless of the conditions of its use. These different considerations will, however, doubtless produce definite effects on the progress that will be made, and, as progress continues and engineering resource

one occasion driven to considerable altitudes, the engine stopped purposely or inadvertently, and a safe soaring descent to the ground accomplished. The Montgomery machine, built primarily as a glider, can be dropped upside down in the air, even with loads, and such is its automatic stability that it invariably rights itself and comes to the ground as gently as a parachute. The Antoinette, Bleriot, Voisin, Curtiss, R. E. P. and many other successful flyers likewise have proved safe gliders with engines stopped. Particularly significant in this connection were Latham's two descents, enforced by engine failure, into the waters of the English Channel—once without even wetting his feet! Other experiences showing that engine failure does not necessarily mean serious disaster have become very numerous within the past few months, (May, 1910) in the use of practically every operative aeroplane that has been built.

makes of the trackless air an unrestricted highway of ever-increasing stability, those of the sky pilots whose temerity is greatest may be expected to become more and more venturesome and capable, so that the development of the flying machine, from commencing with cautious flights in favorable weather, at moderate speeds and low altitudes, and over surfaces upon which landing is comparatively safe, must in time progress to exceedingly rapid travel at somewhat greater heights, and with less regard to the state of the weather or to the character of the surface beneath.

Aerial navigation offers little prospect of ever becoming safe to the extent of relieving those who

**DANGERS IN
ALL TRAVEL**

take it from the common chances of life and death, but it does most emphatically promise that its hazards per passenger carried a given distance will not exceed the corresponding hazards of terrestrial and aquatic transportation. The railroads of the United States alone exact an annual toll of 12,000 persons killed and 72,000 injured, yet many very timid individuals think nothing of riding for hours at a time, at speeds of forty, sixty, and eighty miles an hour, along the tops of precipitous embankments and over unguarded bridges and trestles, with their safety never for a moment independent of the somewhat precarious hold of thin wheel flanges on the smooth edges of narrow rails. Thus does familiarity breed contempt. Nevertheless, compelled to a choice between being plunged to the ground through a distance of, say, fifteen feet in a light, elastic, and protecting structure of wood, wire, and fabric, against the proposition of rolling a similar distance down an embankment, surrounded by

the crushing mass of a railway coach, what sane individual would prefer the hazards of the latter?

As progress continues and safety becomes more and more assured under conservative and reasonable

**FEAR A HABIT
OF MIND** conditions, the timid will in increasing numbers venture first trips as passengers and be reassured by their experiences, until the time will arrive when to fear to travel by air will be to class one with the people who today are afraid to dare the risks of rail and water travel. A gradual overcoming of the inertia of the mind appears to be an essential process in reconciling the generality of people to innovations. Even in the cases of many institutions of the longest standing there are persistent inconsistencies in many people's attitudes. For example, the automobile, which compared "passenger-mile" against "passenger-mile" is found responsible for far fewer fatalities than regularly attend the use of horses, still is regarded as a sort of death-dealing juggernaut by many normally sensible persons. Likewise, it is commonplace to find people thoroughly hardened to travel by the most dangerous type of rail vehicle, the street car, who cannot restrain a feeling of terror at the thought of travel by steamship, which is statistically provable to be any number of times safer. At the time this is written the power-driven heavier-than-air flyer has been responsible for the death of only eight individuals in the whole world, despite an aggregate of experimental flights totalling fully 150,000 miles.

Undoubtedly the first commercial applications of aerial vehicles will be to classes of service involving minima of human risk with maxima of utility—services such as the conveyance at high speed of special

classes of mail and express matter by aeroplanes, each requiring for its management only a single operator, or the rapid distribution of newspaper matrices and illustrations under similar conditions. Next may come the daring spirits who will take desperate chances in the exploration and prospecting of remote and unsettled regions—not to consider the red-blooded few who from the beginning find in navigation of the air a new means of reckless sport and dangerous recreation, chiefly interesting in the improvements that result from their successes and the lessons that are gleaned from their mishaps.

To any one who has kept abreast of recent progress it is genuinely amazing that there are still so many who question this matter of commercial applications. Many who even concede that the flying machine may find important application in warfare and meet with considerable success in sport, still are disposed to deny that it ever can find extensive use as a commonplace, every-day means of transportation. Such persons mistake the bounds of their own knowledge for defects in the thing examined, and see in every failure of an experimental mechanism, no matter to what cause due, a conclusive condemnation of a whole proposition, and when they find themselves astute enough to glimpse a limitation, no matter how trifling, its subtraction from the original quantity clearly leaves a remainder of zero. Yet an inability to fly at all through not knowing how is a distinctly different thing from a mere cessation of flight from breakdown. The first leaves mankind as positively unable to travel in the air as to travel to Mars. The second is with perfect reasonableness comparable with such

negative disabilities as broken flanges, punctured tires, leaking hulls, and the like, which similarly may terminate particular trips by particular means in delay and even in death.

As for limitations, it certainly is to be admitted, for example, that the aeroplane appears totally unsuited for urban travel. In its

**LIMITATIONS
EXPECTED**

present most successful forms it requires special devices or, at least, considerable clear and unobstructed areas for starting and alighting. But for interurban travel, on the other hand, these limitations fail to constitute objections of material magnitude. There is no more reason for expecting the aeroplane to find its utility by developing a facility in maneuvering through mazes of wires and alighting amid street traffic than there would be for condemning Atlantic liners because they have to dock at Hoboken instead of sailing up Broadway. Undoubtedly the time will come when it will be considered quite as reasonable that the beginnings and endings of aerial voyages should involve the presence of special launching and landing facilities, as it is that railway trains should travel from station to station. No type of transportation is unlimitedly flexible. Rail vehicles are confined to rails, automobiles must keep to roads or good surfaces, water craft cannot leave the water, bicycles require at least a fair path, and not even beasts of burden and men walking can disregard all topographical difficulties. Against these, surely the ability of the air vehicle to progress in an air line at its high and maintained speed from selected start to selected destination, always regardless of what may be beneath, and ever ready should necessity compel to settle under control and without immediate danger

upon any fair area of unencumbered land or water space, may be regarded as a form of flexibility sufficiently valuable to offset the lack of other sorts. Moreover, there is some reason for expecting that small aeroplanes and helicopters may arrive ultimately at such reliability and perfection of control that it will be feasible to direct them from or upon almost any place that affords space to accommodate them.

Particularly interesting is the relation of aerial navigation to war—it appearing more than probable

**RELATION
TO WARFARE.**

that this latest of man's inventions will serve first in adding to the terrors of and then in the laying of this grim specter of the centuries. For aside from all mere tactical questions of airships versus battleships it is most of all to be considered, as a very few military authorities have pointed out, that in the development of the flying machine there is placed for the first time in history, in the hands of weak and strong combatants alike, a weapon capable of as effective and unpreventable direction against the kings, congresses, presidents, and diplomats who declare war as it is of direction against the fighting men on the faraway battlefronts. Already more than one great military and naval captain has suffered disquieting visions of what will happen when, maneuvering unopposed and unseen in the obscurity of the night, not merely one or a few, but veritable swarms of light aeroplanes, in twenty-thousand lots costing no more than single dreadnoughts, commence trailing assortments of high explosives at the ends of thousand-foot lengths of piano wire, over cities and palaces and through fleets and armies.

Many authorities are inclined to disparage the

fighting utility of the aeroplane, basing their views on the fact that it has been demonstrated exceedingly difficult to drop bombs with any considerable accuracy from great heights. But from a slow-moving aeroplane flying very low it should be an easy matter to cast generous parcels of picric acid or fulminate of mercury into the twenty-foot diameters of a battleship's funnels. The answer that such an attempt might be foiled by the use of searchlights and quick-firing guns is one that contemplates attack by only one or two of the air craft, rather than to the concerted descent of a whole host of such emissaries of destruction, each manned by a competent and determined crew, realizing that if only one of the wasp-like swarm achieves its purpose the picking off of a few by lucky shots or extraordinary gunnery will be fearfully avenged.

Fancy for a moment the disillusionment to come when in some great conflict of the future a splendid up-to-date battleship fleet of the traditional order, with traditional sailors, traditional admiral, and traditional tactics, finds itself beset in midseas by a couple of great, unarmored, liner-like hulls, engined to admit of speeds and steaming radii such as will permit them

AN to pursue or run away from any
IMAGINATIVE armored craft yet built, and designed
SPECTACLE with clear and level decks for aeroplane launching. Conceive them provided with storage room for hundreds of demountable aeroplanes, with fuel, repair facilities, and explosives, and with housing for a regiment or two of expert air navigators. Then picture the terribly one-sided engagement that will ensue—the thousands of tons and millions of dollars' worth of cunningly-fashioned

mechanism all but impotent against the unremitting, harrying, and reinforced attacks from aloft, and unable either to escape from or give chase to the enemy's floating bases of supplies, which, ever warned and convoyed by their aerial supports, will unreachably maneuver out of gun range, picking up from the water, reprovioning, remanning, launching and relaunching their winged messengers of death until the cold waters close over the costly armada of some nation that has refused to profit by the lessons of progress.

The question of aerial travel over water is one of particular significances. Water areas, in common with

**TRAVEL
OVER WATER**

the atmosphere, possess a quality that does not pertain to land—the quality of uniformity. The consequence is that just so soon as means are devised for launching aeroplanes over water, by the use of hydroplane under surfaces, boat convoys (as suggested in the preceding paragraph), or any other serviceable expedient, the way is at once opened to the establishment of transaquatic mail lines utilizing craft provided with hull-like floats and made capable of flying with almost perfect safety just above the wave crests. Indeed, it is quite to be anticipated that the institution of some such service may constitute the first serious commercial exploitation of the aeroplane. A special incentive to experiment in this direction is the low speed of even the fastest present water travel, by contrast affording to the flying machine an advantage that it does not yet possess in comparison with the higher speeds of land travel. The still unsettled questions of flying radius and motor reliability can be at the outset tentatively evaded by establishing the first

services over the shorter distances, or by stationing patrol boats with fuel supplies at necessary intervals.

It is an irresistible conclusion that the practical utility of the flying machine is no longer to be doubted. The only questions are

CONCLUSION those of the exact methods of realizing these utilities, and the extent of their application when realized. People begin to see that it is absurd to characterize as impossible what has been long accomplished. The bird flies, and there is nothing occult about either the mechanism of the bird or the laws of its operation. Not even the soaring feats of the bird violate any of the laws of aerodynamics or the law of the conservation of energy, however they may scandalize some pedantic conceptions of these laws. Difficulties are no greater than the knowledge required to surmount them, and knowledge is accumulating hour by hour. The time is arriving when it will be no more difficult to maneuver a flying machine than it is to ride a bicycle. Both are distinctly mechanical inventions, both tend unflinchingly to develop from inferior to superior forms, and both have had to encounter various skepticisms.

Here to digress for a moment—let the doubter just consider this case of the bicycle, less as an analogy in mechanism than an analogy in mental attitudes. Think of a “trained engineer” or “conservative business man” of a few years ago confronted with a modern “safety”, exhibited with the assertion that here was a vehicle of perfectly practical utilities, inexpensive to build and operate, capable of considerable speeds under an ordinarily vigorous rider, and perfectly suitable for the use of old people and children under ordinary traffic conditions. Fancy the derision — the criti-

cism that would be leveled at the pneumatic tires, the strictures that would be visited upon the light construction, and, above all, the ridicule that would be heaped upon the proposition of requiring from ordinary people the balancing instinct of the acrobat — then, perhaps, some appreciation will be had of the way most present-day opinions on aeronautics will fit conditions five years from now.

And if all this insistence brings the reader to some belief that possibly, after all, this epic development in transportation is upon us, what of the changes it must involve—the far-reaching influences it must inevitably exert in all possible fields of human thought and activity? Ponder the romance of it—the certainty that it must completely reorganize more than one fundamental factor of the present social order. And believe—as one must unless lost to all optimism and faith—that even present ills work for ultimate good, and inquire what it will mean to live under skies thronged with aerial fleets, to live in a world from which the artificial barriers of national boundaries and the natural barriers of physical characteristics are by advancing intelligence erased past re-establishment.

What must be the result when, with a means of travel limited neither by difficulties of topography nor by the shores of the seas, lending itself perfectly to individual use but not at all to the uses of monopoly, and not confined to the narrownesses of specially built highways, the greatest freedom the individual can possess—the freedom of travel far and wide at will—is vastly enhanced by the vehicles of the skies, vehicles that will prove cheaper to own, maintain, and operate than any other vehicles that have ever existed!

Travel on land will be reduced to the extent that it

is slow, inefficient, expensive, and inflexible. Travel on water will become a mere adjunct to that of the air. The world will be narrowed by the speeds attained. Tariff and exclusion laws will be annulled through the sheer impossibility of their enforcement. And the skies will be as thronged with the craft of man's devising as they are today with the fowl of the air.

Throughout the territories of every nation of the earth there will appear the leveled, circular, landing areas, perhaps provided with strange-appearing starting devices and probably bordered with low, capacious, shed-like housings. Automobiles will be at hand to afford rapid transportation to the business centers of adjoining communities.

There will develop a technique and a language of aerial navigation, and experts will become skilled in contending with the perversity of special mechanisms, in starting and landing under difficult circumstances, in battling with fog and rain and storm, in taking advantage of air currents at different levels, and in seeking out the lanes of the atmosphere in which to add to their speed the sweep of the trade winds.

And over all will soar with the ease of the gull or drive with the speed of the whirlwind, the myriad ships of the air, transforming the face of the heavens. Of many sizes and at many altitudes, midgets and leviathans, close to the earth and up in the clouds—in the days the shadows of their wings will speed over every corner of all the lands and seas, and in the nights of that future time the eye-like gleams of their searchlights will mingle to the uttermost ends of the earth, beacons of science and romance and progress and brotherhood.

CHICAGO, *November, 1909.*

VICTOR LOUGHEED.

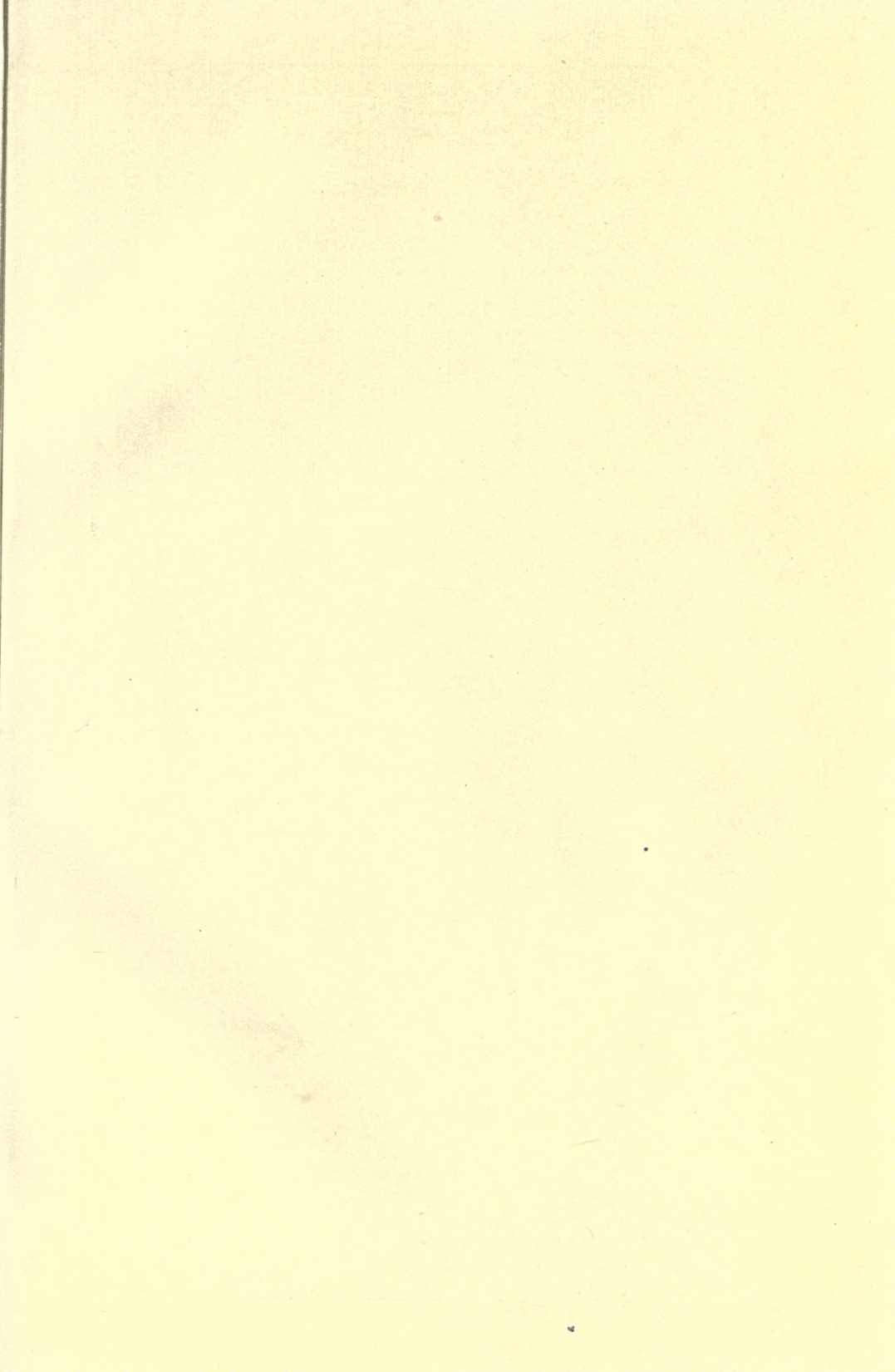

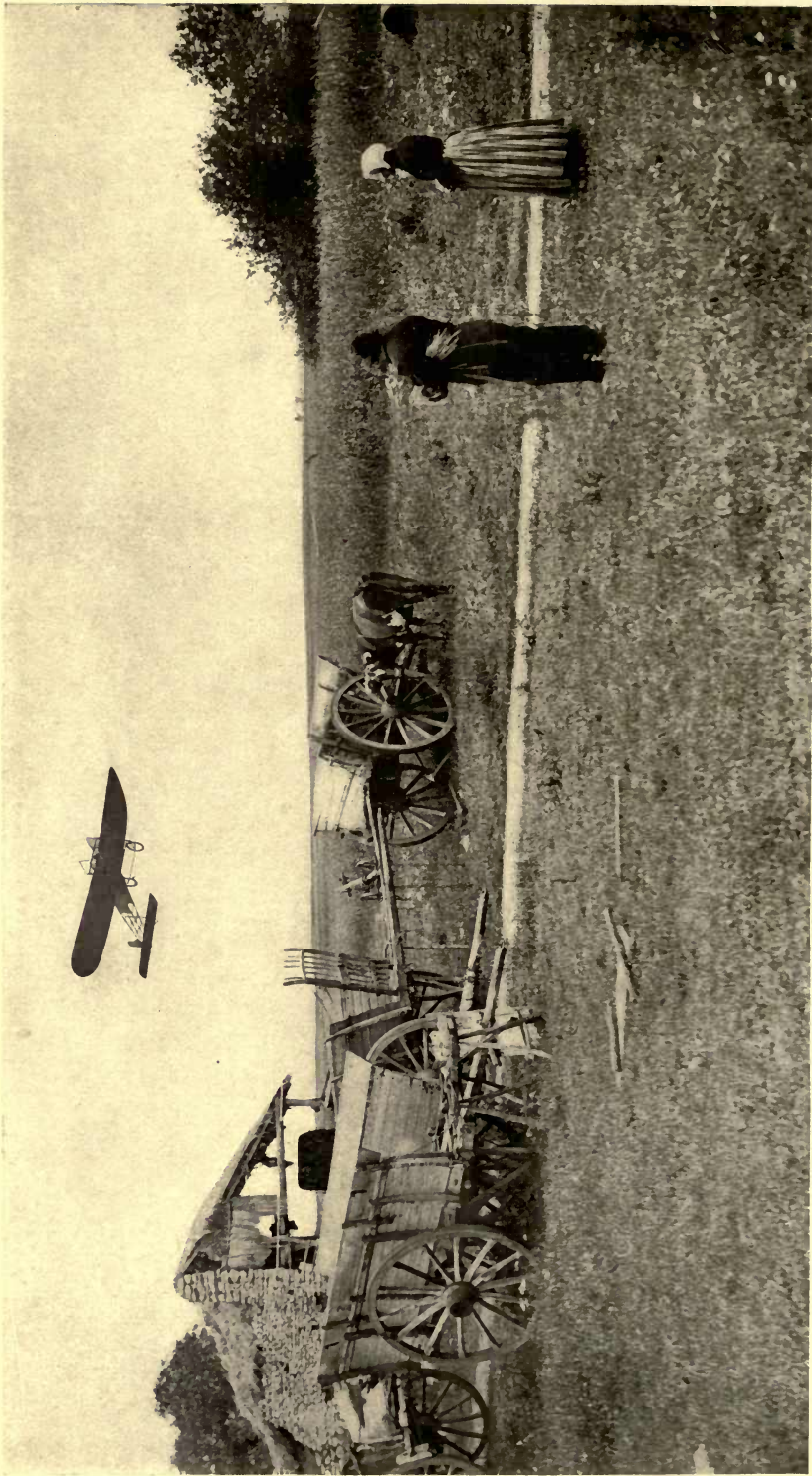

FIGURE 1.—Bieriot's Monoplane No. XI making its memorable cross-country flight from Etampes to Orleans—a distance of 33 miles accomplished in 45 minutes on July 13, 1909.

JOHN S. PRELL
Civil & Mechanical Engineer.
SAN FRANCISCO, CAL.

CHAPTER ONE

THE ATMOSPHERE

At least a brief consideration of the properties and phenomena of the atmosphere, as the medium through which all aerial vehicles must travel and from which they must derive their support, has a logical place in a work of this character.

EXTENT

The extent of the gaseous envelope that surrounds the earth is a subject that has been much investigated by physicists. Knowing the weight of the air, the area of the earth's surface, and the approximate mass of the earth, it is not especially difficult to compute the total weight of the atmosphere, which is found to be about $\frac{1}{1,000,000}$ of that of the rest of the earth.

Determination of the height of the atmosphere is a more difficult problem, whether it be attempted by purely mathematical methods or reasoned more or less empirically from such observations as are available. Were the air of uniform density from the earth's surface to its limit of height it can be easily demonstrated that this upper limit (termed by scientists the "height of the homogeneous atmosphere") would be at an altitude of about 26,166 feet—lower than the highest mountain tops—but

since the air decreases in density at an increasing ratio as the pressure due to air above grows less with each increase in height, until the atmosphere attenuates by imperceptible graduations into a perfect vacuum, no known calculated solution of its ultimate height can be closely depended upon.

The greatest heights above sea level to which man has actually ascended in the atmosphere have been reached with balloons, Glaisher and Coxwell (see Page 74) having attained a probable height of 29,520 feet, while Berson and Süring (see Page 75) undoubtedly reached an altitude of 35,400 feet.

The atmosphere has been explored to much greater heights by "sounding balloons" (see Page 75), the greatest height on record having been reached by a balloon of this type released from Uccle, Belgium, on November 5, 1908. As shown by self-registering instruments attached to this balloon, it rose to a height of 29,040 meters (95,275 feet), over eighteen miles.

Estimates based on the calculated heights of meteors at the times when they commence to become luminous from friction with the earth's atmosphere have been held to indicate that this must extend, in an exceedingly tenuous state, to a height of 200 miles. Other authorities contend that the extreme upper limit cannot be over 100 miles high. In any case, it is an obvious deduction from the barometric pressures recorded at great heights (see Page 56) that $\frac{3}{8}$ of the whole atmosphere is below 30,000 feet, $\frac{9}{10}$ below 43,000 feet, and $\frac{14}{17}$ below 95,275 feet.

PROPERTIES AND CHARACTERISTICS

The atmosphere being chiefly composed of several common forms of matter, its principal physical properties and characteristics have been well investigated.

WEIGHT

According to Regnault, air at sea level, freed absolutely from water vapor, carbon dioxide, and ammonia, weighs .0012932 grams to the cubic centimeter at zero Centigrade, under a pressure of 760 millimeters of mercury in the latitude of Paris ($48^{\circ} 50' N.$), and at a height of 60 meters above sea level. In English equivalents this is approximately equal to .080681 pound to the cubic foot—or 12.384 cubic feet to the pound—at sea level in the latitude of Washington, D. C. Ordinarily, not freed from water vapor and other impurities, air at sea level, at $32^{\circ} F.$, can be taken to weigh very close to .080728 pound to the cubic foot.

At any height above sea level a given volume of the atmosphere weighs an amount less than a similar volume at sea level in exact proportion to the difference in barometric pressure, other conditions being equal. Thus, at the 29,000 feet reached in the Coxwell and Glaisher balloon ascent the weight of the air was only .052171 pound to the cubic foot.

The weight of the air is an important consideration in the design of aerial vehicles, particularly in the case of lighter-than-air constructions,

since these are enabled to float only by being lighter than the volume of air they displace. With heavier-than-air machines the weight of the apparatus is sustained by the quantity of air acted upon, varying with area of surfaces, rapidity of the action, and mass of the air affected.

COMPOSITION

Air consists chiefly of oxygen and nitrogen mechanically admixed (not chemically combined) in the proportion of about 21 volumes of oxygen to 79 volumes of nitrogen (by weight the proportions are 23.16 units of oxygen to 76.77 of nitrogen). In addition to these principal ingredients air carries minute quantities of many other constituents, some of which appear in the constant proportions indicative of normal components, while others are variable with locality and circumstance.

Among the more evident of these minor constituents of the atmosphere are water vapor, carbon dioxide, ammonia, nitric acid, argon, helium, neon, krypton, and ozone, besides quantities of dust, germs, and other minute solid particles held in suspension. The water vapor may represent as much as $2\frac{1}{2}$ parts by weight of saturated warm air, but ordinarily the quantity is much less. The carbon-dioxide content varies from .0043 in the country to as much as .07 or even .1 of the whole weight of the air in cities. This gas, which is produced in the lungs of all animals, from which it is

constantly given off as a waste product of the continuous oxidation of the blood that is essential to life, to the vegetable kingdom bears the relation of a food, thus beautifully disclosing the wonderful adaptation of all natural phenomena to interlink with one another. For in the leaves of all plants there constantly goes on a mysterious absorption and fixation of the carbon from the carbon dioxide of the atmosphere, apparently by some not understood action of the green chlorophyll they contain, while the oxygen thus freed from its combination is in this case the waste product.

Argon constitutes about .01 of air. The total amount of ammonia and other less important gases is probably less than .01 in the lower atmosphere, though there are reasons for supposing some of these gases to be more abundant above. The ammonia in air is generally stated as amounting to about .000006 of the total weight, while neon is present to the extent of about .00001. Both argon and helium have been determined to exist at all heights up to 46,000 feet, but above this height no helium has been detected. Ozone, which is an allotropic form of oxygen, varies from none in cities to .0000015 in the country, and is more abundant in summer, especially during thunderstorms and high winds. The amount of dust in the air is much the greatest in the lower strata of the atmosphere, to which it is so closely confined that balloonists are frequently able to discern definite dust levels at certain heights.

COLOR AND TRANSPARENCE

Though in small quantities air is without any color that can be perceived, the fact that distant objects seen through it acquire a blue tinge, which also appears as the color of the sky, makes it evident that even the smallest quantity of air must faintly possess this hue.

While commonly regarded as perfectly transparent, air nevertheless offers considerable obstruction to the passage of light rays and to vision. Indeed, were the atmosphere in undiminishing density to extend to any great height it is a safe conclusion that its presence would prevent our seeing even the brightest of the heavenly bodies. As it is, the whole amount of air above the earth being only equivalent to 26,166 feet of air at sea-level density, it offers more obstruction to vision in a lateral direction than in the vertical—a fact that becomes very apparent when it is attempted to make out distant details from a mountain top or balloon, affording an outlook of many miles in a horizontal direction. Weight for weight, air is little more transparent than glass or water, 30 feet of the former and 18 feet of the latter being equivalent to the entire height of the atmosphere and offering little more obstruction to vision, especially when compared with air containing much dust or water vapor.

AIR AT REST

Air in a state of rest, subjected to any given but unvarying conditions of pressure, temperature,

and composition, presents comparatively few and simple problems. Of its static properties, the most important are its compressibility, those relating to the effects of temperature, and those relating to its phenomena of liquefaction and solidification.

COMPRESSIBILITY

Air in common with all other gases has the quality of compressibility—a quality not measurably possessed by most liquids. For this reason its volume is always proportionate to the pressure upon it, it expanding with every reduction in pressure and occupying less space with every increase. Through a considerable range of pressures the space occupied is almost directly proportionate to the pressure—a doubling of the pressure reducing the volume by one-half, etc. Air cannot be compressed without the work expended appearing in the form of a rise in temperature, and, conversely, allowing compressed air to expand always results in a lowering of temperature.

EFFECT OF TEMPERATURE

Heating or cooling of air causes it to expand or contract. Through a considerable range of the commoner temperatures such expansion or contraction is closely proportionate to the amount of change in temperature. This property is taken advantage of in hot-air balloons, as explained on Page 97. Heating air that is confined results in an increase of pressure, and cooling compressed air results in a decrease of pressure.

LIQUEFACTION AND SOLIDIFICATION

Almost every known form of matter, whether normally appearing as a solid, liquid, or gas, can by sufficient change in the conditions of temperature and pressure be made to assume any of these three conditions. Thus the hardest rocks and the strongest metals can be melted into liquids and volatilized into gases, while practically all known liquids can be solidified—as in the familiar case of the freezing of water. Likewise, the lightest gases, when subjected to sufficient cold and pressure, assume first a liquid and then a solid form. Air is no exception to this rule, becoming a liquid at -220° Fahrenheit under a pressure of 574 pounds to the square inch—or less, if the temperature be lower. Further cooling causes it to become solid, though the temperature required to produce this condition is so low that it can be attained only with the greatest difficulty.

Liquid air, because of its compact form as a source of oxygen, and its expansion into the gaseous form at high pressure upon exposure to ordinary atmosphere temperatures, often has been proposed as a source of stored energy for motors, but so far no such application has proved successful.

AIR IN MOTION

Air in motion possesses properties that are very little understood, the laws of its dynamic actions and reactions not having been generally investigated or formulated. Particularly with

reference to the operation of heavier-than-air machines is this the case. Indeed, more than one of the world's foremost physicists, even in comparatively recent years, has positively declared aerial navigation to be impossible, basing his conclusions upon difficulties encountered in reconciling the idea of man flight with established hypotheses of aerodynamics. Air, possessing almost perfect elasticity in addition to its weight, fluidity, and other qualities, cannot be set in any but the most simple movements without occasioning a multitude of resultants that are so utterly complex and involved as almost to defy analysis. The result is that even such comparatively simple phenomena as those of the movement of air in pipes and in jets are only understood in a general way, while the work of most investigators of flight problems has had to be almost purely empirical, or, when mathematical, has been unsuccessful. The one conspicuous exception with which the writer is familiar is found in the investigations and experiments of Professor Montgomery, whose conclusions are outlined in the article printed in Chapter 4.

Of the dynamic properties of air, the most important from present standpoints are its inertia, elasticity, and viscosity.

INERTIA

Air, in common with all other matter having weight, exhibits the various phenomena of inertia, which may be defined as the tendency of a mass to

remain at rest, or to continue in uniform motion in a straight line, until acted upon by some disturbing or retarding force. Naturally, air being much lighter than solid and liquid forms of matter, its inertia is less marked than in the case of heavier substances. But that under favorable conditions this is a factor to reckon with is abundantly proved throughout a great range of natural phenomena, from the flight of birds to the extraordinary vagaries of cyclone action. In fact, as one great investigator has tersely expressed a profound truth in form to be appreciated by the man in the street, "the air is hard enough if it is hit fast enough."

ELASTICITY

The property of elasticity is one of the fundamental qualities that distinguish air and other gases from liquids. Air and other gases are in fact the only perfectly elastic substances known—that is, the only substances that will withstand compression to an indefinite extent and for indefinite periods without in the slightest degree losing their ability fully to recover the original volume. Gases compressed under thousands and even hundreds of thousands of pounds to the square inch, for no matter how long a period, instantly and unfailingly expand to any extent permitted by release of the pressure.

It is to a great extent this property that, under favorable conditions, makes for the high efficiencies realized with suitably-designed mechanisms for operating on masses of air (see Page 255).

VISCOSITY

Viscosity is a property of fluids closely comparable to the cohesion of solids and may be defined as the tendency of the molecules to occasion friction when driven against or past one another. The viscosity of air is often stated to be much higher than that of water (not per unit of volume, but per unit of weight), but there is reason for doubting the soundness of this conclusion. However, it is at least true that air possesses viscosity, and that this sets up increasing resistances to movement as the speed of the movement rises. The question of skin friction on aeroplane and propeller surfaces is closely related to that of the viscosity of air.

METEOROLOGY

The matters of climatic conditions, storm phenomena, and temperature, and barometric and electrical conditions in the atmosphere must all, in the nature of things, be of the utmost interest to both present and future air navigators.

Meteorological conditions may be broadly grouped in two classes—the first comprised of conditions of a primary or static character, and therefore not directly inconsistent with fair weather, while the second class includes such meteorological phenomena as are directly related to winds and storms.

Generally speaking, there are three fundamental or primary changes to be noted in the at-

mosphere in a given period in any locality—changes in temperature, changes in barometric pressure, and changes in humidity. Secondary effects, usually rather definitely resultant from the foregoing, are the condensation of moisture and its precipitation—in the form of rain, snow, or hail—and the movement of the air in the form of winds.

TEMPERATURE

Besides the seasonal variations in temperature, which vary greatly with locality, there is the remarkably uniform lowering of temperature with increase of height, the atmosphere being warmest at or near the surface at sea level and progressively colder at greater altitudes, as is evident in the phenomenon of perpetual snow on high mountains, even in warm climates.

Observations with sounding balloons have discovered temperatures lower than -100° F. at great heights, with -50° commonly prevailing, even in summer. The lowest temperature ever recorded at the earth's surface is -90° F., observed in Siberia—this degree of cold exceeding any that has been recorded elsewhere on the surface, even in polar exploration. At the other end of the range are temperatures of about 140° above zero Fahrenheit, noted in India, the Sahara, the southwestern United States, Australia, and elsewhere in the desert and equatorial regions of the world.

The following two tables of sounding-balloon records will be of interest:

FROM SAINT LOUIS, MAY 6, 1906

FROM SAINT LOUIS, MAY 10, 1906

HEIGHT ABOVE SEA LEVEL	TEMPERATURE
623 feet.....	57.2° F.
3,281 feet.....	46.4° F.
6,562 feet.....	31.2° F.
9,843 feet.....	21.2° F.
13,123 feet.....	15.8° F.
16,404 feet.....	17.6° F.
19,685 feet.....	5.0° F.
32,808 feet.....	-52.6° F.
26,247 feet.....	-29.2° F.
29,527 feet.....	-40.0° F.
32,808 feet.....	-52.6° F.
36,089 feet.....	-50.8° F.
39,370 feet.....	-49.0° F.
42,651 feet.....	-54.4° F.
45,932 feet.....	-56.2° F.
49,212 feet.....	-59.0° F.

HEIGHT ABOVE SEA LEVEL	TEMPERATURE
623 feet.....	68.0° F.
3,281 feet.....	59.0° F.
6,562 feet.....	46.4° F.
9,843 feet.....	37.2° F.
13,123 feet.....	21.2° F.
16,404 feet.....	- 6.8° F.
19,685 feet.....	- 2.2° F.
22,966 feet.....	-26.6° F.
26,247 feet.....	-32.8° F.
29,527 feet.....	-45.4° F.
32,808 feet.....	-59.0° F.
36,089 feet.....	-76.0° F.
39,370 feet.....	-70.6° F.
42,651 feet.....	-67.0° F.
45,932 feet.....	-70.6° F.
49,212 feet.....	-72.4° F.
52,893 feet.....	-68.8° F.
54,298 feet.....	-67.0° F.

A remarkable feature well shown in the above is the "permanent inversion layer", or isothermal stratum, of the upper atmosphere, it being noted that at from 33,000 to 49,000 feet—beginning just higher than the tops of the highest mountains—a minimum temperature is reached, after which there tends to be a slight but fairly regular rise. This change has been discovered to exist all over the world—in both the tropical and temperate zones, near the arctic circle, and over the Atlantic ocean. In the record ascent of the sounding balloon from Uccle (see Page 44) the lowest temperature registered was -108.6° F., at 42,323 feet. At 95,275 feet, the greatest altitude reached, the temperature had risen to -82.12° F.

In the Berson and Süring ascent, on December 4, 1894, the lowest temperature—at 28,750 feet—was -54° F. At the start in Berlin the temperature was 37° F.

BAROMETRIC PRESSURE

The weight of the atmosphere, as shown by the barometric pressure, varies with height, temperature, and latitude. As is elsewhere explained herein, by far the most considerable variations are those due to height, for which reason a high-grade aneroid barometer constitutes a very accurate means of estimating altitude.

At sea level, under normal conditions, the barometric pressure is almost exactly 14.7 pounds to the square inch. At great heights it is much less, as, for example in the Glaisher and Coxwell ascent (see Page 74).

The Uccle sounding balloon recorded a pressure of 1.74 pounds to the square inch at 42,240 feet, and of only .2 pounds to the square inch at its greatest height of 95,275 feet.

HUMIDITY

Humidity is a general term for the presence of water vapor in air, but in the more restricted and more specific scientific sense it is commonly understood to refer to the percentage of saturation—that is to say, to the proportion that the amount of moisture actually present in the air bears to the maximum it might contain. The saturation point varies with temperature—cold air being capable of holding less and warm air more water vapor. At a temperature of about 90° F. a cubic foot of saturated air will contain about $\frac{1}{81}$ ounce, or about $\frac{1}{18}$ cubic inch, of water. Saturated air

cooled to a lower temperature always precipitates its excess of water. This is the explanation of the condensed moisture that is often precipitated from the air on the outside of a glass of cold water, or upon any other cold surface in warm weather, and it has most important bearings upon the phenomena of rain and snow fall.

The moisture in the air is chiefly derived by evaporation from water areas and land wetted by rains or floods.

CONDENSATION OF MOISTURE

This always occurs when the atmosphere is cooled until the amount of water present in it amounts to more than the saturation quantity for the given temperature, and the result is ordinarily a precipitation of rain, snow, or hail—though it is established that under certain conditions moisture thus precipitated may pass into vapor, or be frozen in exceedingly minute crystals, and so retained in suspension in the form of clouds.

WINDS

Winds, amounting simply to more or less rapid movement of portions of the atmosphere with relation to the earth's surface, present many aspects of interest to the air navigator, and are worthy of his profoundest consideration.

Atmospheric movements vary in direction, velocity, and duration, and in the presence of ascending or descending components, and are classified according to their velocity, direction,

and duration into the different classes of storms and winds.

Winds are supposed to be due chiefly to variations in temperature, though they are affected by tidal movements in the atmosphere and influenced by the earth's rotation. The latter, however, cannot be of very great effect because, though the equatorial speed of rotation is over 1,000 miles in hour, everything terrestrial is so subjected to the earth's attraction that it must be moved uniformly along without materially lagging behind, as might be the case were the rotation irregular or intermittent.

Tidal currents in the air, caused by the attraction of the sun and moon, are well established to exist, but because of the comparatively small mass of the air they do not vary the barometric pressure more than $\frac{1}{20}$ ounce at sea level, and therefore cannot be of any considerable effect in establishing or controlling winds.

Changes in temperature produce effects of much greater magnitude. Air heated through a range of 50° F. is dilated about one tenth of its volume—with corresponding lightening of its weight per unit of volume. The result, therefore, of a change of temperature in any portion of the atmosphere is a compression or attenuation that can be relieved only by a flow of air from or to the locality affected, with a violence proportionate to the suddenness and amount of the temperature change and the quantity of air it affects. Also, air being lightened by heating, heated bodies of it

have a tendency to rise, causing an upward compression with a radial inflow from all surrounding places to occupy the spaces thus becoming vacated. Again, air thus caused to ascend into the upper regions of the atmosphere, where, as has been explained, conditions of the most intense cold prevail throughout the year, becomes cooled and thus is turned from its vertical into a horizontal and finally a descending course.

The fact that a rapid fall of the barometer—indicating a reduction in the weight of the air—almost always precedes violent winds, seems proof positive of the soundness of the accepted theories of wind causation.

There are two principal modes of heating to which the atmosphere is subjected. One is the regular diurnal heating due to the alternation of day and night, a wave of heated air progressing around the world with the sun while a converse cool wave follows the night. The other type of heating is that to which the atmosphere is subjected over great areas in contact with the earth—a type of heating that becomes particularly manifest over great areas of prairie or desert country in summer.

Coastal Winds are common along almost all seacoasts and even along the shores of large lakes. They seem distinctly due to the effects of temperature, and, commencing with a light breeze from the sea in the morning rise to a stiff wind by midday, subsiding again to a calm by evening. Then, as darkness comes on, a breeze sets in from the land,

reaching its maximum velocity sometime in the night, and thereafter dying down towards morning. These winds are rarely felt more than twenty miles out to sea or inland, and investigation with kites and balloons has shown them to be invariably accompanied by an opposite movement of the air at some distance above—usually at a very moderate height (500 to 1,000 feet). This, besides proving that the air travels in a complete circuit, goes a long way towards explaining the phenomenon, it being reasoned that as the air is warmed over the land by the heat of the day it rises, is replaced by air flowing in from the sea, and then flows seaward at an upper level because of the reduced pressure in that direction. At night the land is more quickly affected by the withdrawal of the sun's rays, so now the ascending current commences over the sea, with a sequence of results exactly the converse of the foregoing.

Trade Winds, so called because of the dependence placed in them by navigators of sailing vessels, are always in the same direction but with seasonal variations in the areas they extend over. They are due to cold currents flowing in from the polar regions to replace the warm air that rises from the equatorial regions of the earth. Normally, they would flow directly north and south to the equator, but the influence of the earth's rotation and the configuration of the land and water areas in the northern hemisphere causes them gradually to veer about, as they progressively reach latitudes where the peripheral speed of the earth's surface

is higher, until they flow almost directly west, but slightly north or south (constituting the "north-east trade" and the "southeast trade"). The trade winds follow the sun very closely in their areal variations. Over the Atlantic, for example, they come farthest south in February and go farthest north in August, the northeast trades blowing between 7° and 30° north latitude and the southeast trades blowing between 3° north latitude and 25° south latitude. Between the two is a region of calms, from 3° to 8° wide, which goes as far north as 11° north latitude in August and as far south as 1° north latitude in February.

Above the trade winds there are well established to exist return currents, blowing in the opposite directions. In high latitudes these return currents often come down to the surface and produce easterly trade winds.

Cyclones, Whirlwinds, and Tornadoes are local winds of terrific violence and rotary character, which are started by rapid and intense local heating, with consequent rapid rising of locally-heated atmosphere—at such a rate that the radial inflow of adjoining air assumes a rotary movement similar to that of water in draining out through a hole in a vessel. The vortex of the storm is at the center of this rotation, where most terrible wind velocities are attained if their frightfully-destructive effects are any criterion. Fortunately cyclones are usually very small in their areas of maximum violence and are of comparatively brief duration.

Ascending Components in apparently horizontal winds, and especially in those blowing over horizontal surfaces, have occasioned much discussion and speculation by students of aerial navigation because of the supposed bearing upon the sustained soaring flight of certain birds. Now, though it is fairly established that such ascending components exist, it seems doubtful whether they constitute the essential means to soaring flight. Nevertheless, it is evident that indefinite progress in a horizontal direction might be made with a gliding machine, were the air continuously rising. Indeed, the resulting condition might be likened to that of a vehicle coasting down a hill that rose as fast or faster than the vehicle descended. Rising currents are now attributed to two principal causes—one, the slant of irregular country over which winds may blow, and the other, over flat country, the retarding friction of the lower strata of air on the surface.

Another class of rising currents is that due to heating of the air. Chanute is authority for the statement that such vertical currents, unaccompanied by adjacent horizontal currents, may flow as fast as from 6 to 10 miles an hour.

Wind Velocities vary from those of most imperceptible zephyrs to the immeasurable violence of the cyclone. The highest winds that have been successfully recorded by anemometers are slightly in excess of 100 miles an hour, this rate being briefly reached nearly every year, for example, at the weather station at Point Lobos, California.

Ordinarily wind velocities average much lower. In 650 different daily observations of wind movement over the five great oceans, taken on board the "Challenger" during a $3\frac{1}{2}$ years' cruise that ended in May, 1876, the mean hourly wind velocity was 17 miles. In 552 observations taken on land during the same period the mean hourly velocity amounted to only $12\frac{1}{2}$ miles.

Wind velocities are much greater at high altitudes than lower down. Kite experiments in a wind of $22\frac{1}{2}$ miles an hour at the surface have on at least one occasion indicated a velocity of over 130 miles an hour at a great height.* Very moderate heights are enough to cause a considerable difference, and observation will often show a wind velocity of twice that at the ground, at a height of no more than 50 or 60 feet.

Besides to major changes in velocity and direction, winds are subject to a multitude of minor variations and fluctuations, almost from moment to moment, especially in proximity to terrestrial irregularities, which retard and deflect them and otherwise interfere with their free sweep. Recording instruments show that such fluctuations are often quite incessant, occurring with great frequency and throwing the air into billows and whirls and irregularities—which to cope with safely is certainly to be regarded as one of the more serious problems of aerial navigation.

* It is to be borne in mind that at very great altitudes the small weight of the air per unit of volume increases its mobility and reduces the force of its effects.

ATMOSPHERIC ELECTRICITY

The presence of electrical action in the atmosphere, due to the accumulation of enormous static charges of current generated presumably by friction of the air upon itself, accounts for the various phenomena of lightning and thunderstorms. To the student of aerial navigation the most interesting aspect of these phenomena is their danger from the standpoint of the balloonist, it being well established that hydrogen balloons have been set on fire by electrical discharges, often of otherwise quite imperceptible character.

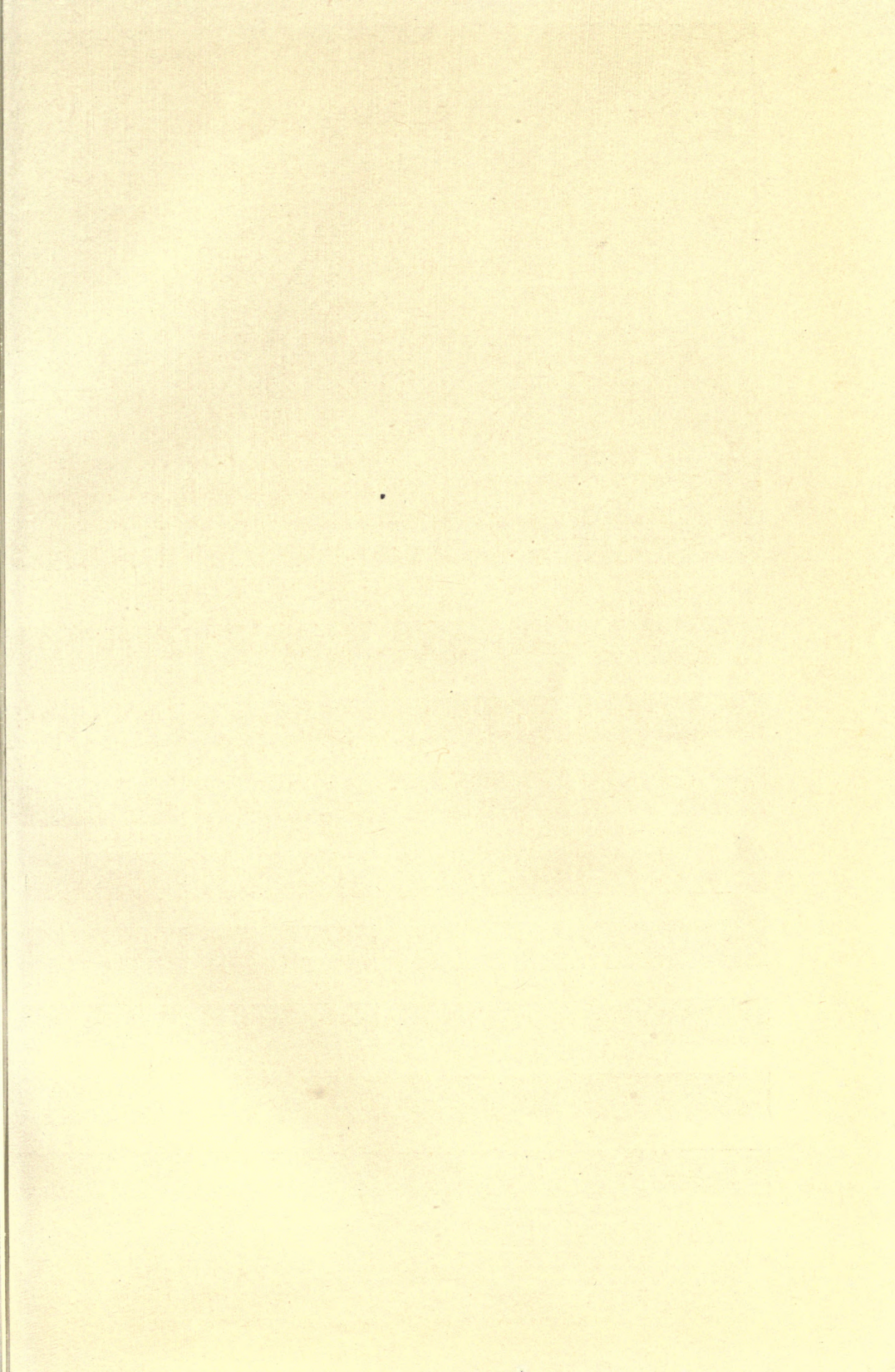

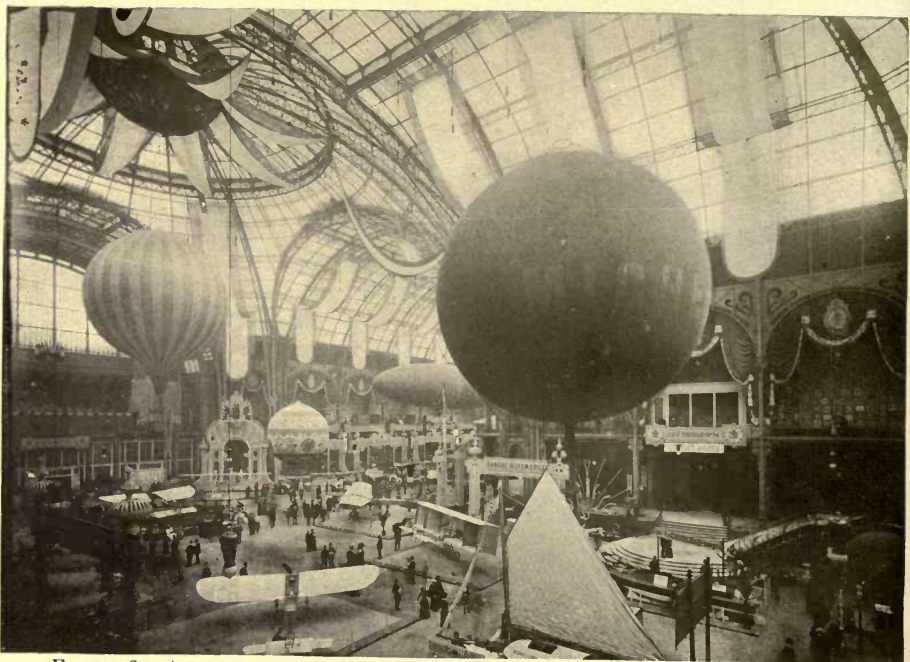

FIGURE 2.—A corner of the Aeronautical Exhibition held in the Grand Palais, Paris, during October, 1909. The small decorated balloon in the background is a reproduction of the original Montgolfier balloon of 1783—the first ever made.

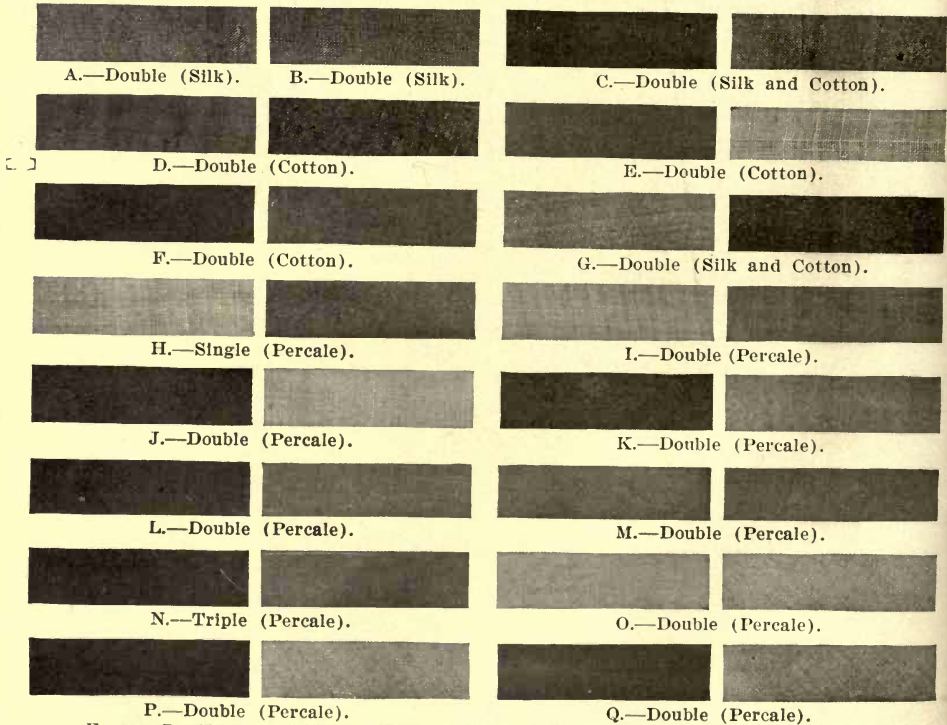

FIGURE 7.—Texture of Modern Balloon Fabrics—Reproduced Actual Size. Of these, A is a very light fabric; B is similar but heavier; C is the material of the Baldwin government balloon; D, E, and F are heavy fabrics; G is similar to C, but heavier; H is a very light fabric for sounding balloons; I is a very light double fabric, used in the Zeppelin dirigibles; J and K are double fabrics with the layers crossed to add strength; L and M are exceedingly heavy double fabrics, for semi-rigid and non-rigid dirigibles; N is one of the heaviest balloon fabrics used, weighing $14\frac{1}{2}$ ounces to the square yard; and O, P, and Q are all high-grade diagonal fabrics with gray rubber to retain the gas and red surfaces to resist sunlight.

CHAPTER TWO

LIGHTER-THAN-AIR MACHINES

Though as a vehicle of practical utilities it is fast losing ground in comparison with the developing forms of heavier-than-air fliers, and seems condemned by insuperable objections inherent in its very principle of operation, the lighter-than-air machine—the balloon—was nevertheless the first with which man succeeded in sustaining himself in the air for considerable periods of time.

Since the essential feature of lighter-than-air craft is their ability to float in the air much as a vessel floats in the water, and since the only substances that even approach air in lightness are also gases, it follows that the design of no conceivable sort of lighter-than-air machine can escape the necessity for two essential elements—space occupied by something lighter than air, and an envelope of heavier-than-air material to enclose this space—with the relations between these two elements so proportioned that the lifting force of the gas is sufficient to overcome the weight of the envelope. In any practical air craft, to the weight of these primary essentials must be added such further weight of structure as may be considered

necessary to afford passenger or cargo accommodation, and such further quantity of gas as may be required to lift such passengers or cargo as it may be planned to carry.

NON-DIRIGIBLE BALLOONS

The most elementary type of balloon is that designed for mere ascension and flotation in the air, with no attempt at navigation in a lateral direction except as such lateral travel may result from favorable winds. It was a very early suggestion in the history of the balloon that, inasmuch as the direction of the winds frequently varies with differences in altitude, upper currents often flowing directly contrary to those near the surface, systematic prospecting through these different currents by control of height might result in control of the direction of travel. Yet in the hundreds of attempts made to work something practical out of this idea, nothing of real value has developed.

HISTORY

If somewhat uninvestigated, but in nowise discredited Oriental history is to be believed, the invention of the balloon is properly to be ascribed to that inscrutable people, the Chinese, who, according to a French missionary writing in 1694, sent up a balloon in celebration of the coronation of the emperor Fo-Kien, at Peking, in 1306. Furthermore, this ascension is stated to have been only the carrying out of an established custom, rather than the first ever made by the Chinese. It

is not recorded whether or not any of the Chinese balloons ever carried passengers.

The first European appreciation of the principle by which a balloon is made to ascend appears to have been due to a Jesuit, Francis Lana, who in a work published at Brescia, Italy, in 1670, proposed an airship sustained by four hollow copper vacuum balls, each twenty-five feet in diameter and $\frac{1}{25}$ inch thick, affording a total ascensional force of about 2,650 pounds, of which some 1,620 pounds would be the weight of the copper shells, leaving 1,030 pounds for the weight of the car, passengers, etc. The difficulty of securing sufficient strength to withstand the pressure of the atmosphere Lana assumed would be met by the domed form of the surface, but in view of the fact that the total pressure on each sphere would figure over 4,000,000 pounds, the possibility of resisting it with so thin a shell still remains to be demonstrated.

In 1766 Cavendish made public his estimations of the weight of hydrogen, immediately following which Dr. Black, of Edinburgh, made a calf-gut balloon which, however, proved to be too heavy for sustentation by the hydrogen it could contain. A few years later, Tiberius Cavallo, to whom a similar idea occurred, found bladders to be too heavy and paper too permeable, but he did succeed in inflating soap bubbles with hydrogen in 1782, with the result that they floated upwards until they burst.

It is a somewhat remarkable coincidence that

just as the modern aeroplane has been most prominently associated with the names of two brothers, so to two brothers, Stephen and Joseph Montgolfier, is generally ascribed the invention of the balloon. Tradition has it that, inspired originally by reading Dr. Priestly's "Experiments Relating to Different Kinds of Air", the Montgolfiers, who were sons of Peter Montgolfier, a paper manufacturer of Annonay, France, were next impressed from observation of the clouds with the idea that if they could fill a light bag with "some substance of a cloud-like nature" it would similarly float in the atmosphere. Accordingly—with the notion of using smoke as the required "substance"—Stephen, who appears to have been the prime mover in the enterprise, started to experiment with large paper bags, of capacities up to 700 cubic feet, under which were burned fires of chopped straw. Though success immediately resulted, it is interesting to note that it was some time before the brothers realized that the real source of the lifting effect was the heating of the air within the bags and not the smoke with which they sought to fill them.

Having demonstrated the possibility of making small balloons ascend, the Montgolfiers next built a spherical paper balloon thirty feet in diameter, with a capacity of about 13,000 cubic feet and possessed of a consequent ascensional force, when inflated with heated air, of probably 500 pounds. This balloon was sent up from Annonay, without passengers, on June 5, 1783, in the presence of

many spectators. It rose to an estimated height of a mile and a half before the air within it cooled sufficiently to cause its descent, ten minutes after its release. A modern reproduction of one of the first Montgolfier balloons is shown in Figure 2.

Following this first balloon ascent, on August 27, 1783, M. Faujas de Saint-Fond, a naturalist; M. Charles, a professor of natural philosophy in Paris, and two brothers by the name of Robert, sent up a hydrogen balloon from the Champ de Mars, in Paris. This balloon, thirteen feet in diameter and weighing less than twenty pounds, was made of thin silk coated with caoutchouc, and required four days for its inflation, the hydrogen being generated by the action of 500 pounds of sulphuric acid on half a ton of iron filings—a process that only very recently shows signs of being superseded (see Page 99). When liberated the balloon rose rapidly to a height of about 3,000 feet, burst, and then landed three-quarters of an hour later in a field near Gonesse, fifteen miles away, where it was destroyed by terrified peasants.

The next balloon ascent was that of a spherical bag, of linen covered with paper, made by the brothers Montgolfier. This balloon, which was the second of the same material—the first having been destroyed by a storm of wind and rain before it could be used—had a capacity of 52,000 cubic feet, and was sent up from Versailles, France, on September 19, 1783. A small car was attached, in which were placed a sheep, a cock, and a duck, which thus had thrust upon them the distinction

of being the first balloonists. The descent occurred eight minutes after the start, and the sheep and duck were uninjured. The cock had not fared so well, and his condition was gravely attributed by the savants present to the effects of the tenuous atmosphere of the upper regions. Calmer subsequent diagnosis, however, indicated that he had been trampled upon by the sheep.

The first ascent of a man-carrying balloon was one ventured by Pilatre de Rozier, who entrusted himself to a captive balloon, built by the Montgolfiers, on October 15, 1783. The balloon was permitted to ascend only to a height of less than 100 feet, at which elevation it was kept for a period of a little over four minutes by continuous heating of the air inside of it by means of a fire of chopped straw. Following this, on November 21, 1783, de Rozier and a friend, the Marquis d'Arlandes, made the first free balloon ascension, in which the start was from Paris, with the descent safely accomplished in a field five miles from the French metropolis after about twenty minutes of drifting at not over 500 feet high.

It is recorded that Benjamin Franklin, who was a witness of this first aerial voyage, was asked by a pessimistic spectator for his opinion of the utility of the new device, to which Franklin is said to have replied, "Of what use is a new-born babe?"

Only seven days after the foregoing, on November 28, there was made from Philadelphia, under the auspices of the Philosophical Academy of that

city, a balloon ascent that has escaped the attention of most of the writers on the subject. The enterprise was in charge of two local scientists, Hopkins and Rittenhouse, who first made experiments by sending up animals in a car attached to forty-seven small hydrogen balloons. They then persuaded one James Wilcox, a carpenter, to go aloft, with the result that to this man belongs the honor of having first ascended with a hydrogen balloon. The descent, which barely missed being into the Schuylkill River, was so abrupt that the lone passenger dislocated his wrist.

The first European ascent with a hydrogen balloon was made on December 1, 1783, by Charles and Robert, who safely accomplished a twenty-seven mile trip at about fifteen miles an hour from Paris to Nesle, France, in two hours, reaching a height of 2,000 feet. At Nesle a landing was effected and Robert got out, whereupon Charles made a further journey of two miles in the course of which it is asserted he rose to a height of 10,000 feet, at which altitude he suffered severely from cold and the rapid lowering of the atmospheric pressure. The balloon used on this occasion was over twenty-seven feet in diameter, sewed up of varnished silk gores, and on the whole very well designed, being provided with a net and valve. The car was boat-like, eight feet long, and weighed 130 pounds. Ballast was used to control and a barometer to measure the height. Indeed, nearly every essential feature was closely similar to the

corresponding features in the best modern gas balloons, which therefore date back more definitely to the ingenious Charles than to any other investigator.

During 1784 balloons became common throughout all Europe and many successful ascents were made. The first woman to ascend in a balloon was a Madame Thible, who went up from Lyons, France, during this year.

On January 7, 1785, a remarkable balloon voyage was made with a hydrogen balloon by Jean-Pierre Blanchard and an American physician named Jeffries, these two embarking from the cliff near Dover castle and crossing the English Channel to the forest of Guines, in France, the distance being made with a favorable wind in something less than three hours. In an attempt to repeat this feat, on June 15, 1785, at the age of twenty-eight years, Pilatre de Rozier, the first aeronaut, became also the first victim of aerial travel, he and a friend, M. Romaine, both losing their lives through the balloon, which was of the Montgolfier type, catching fire at a considerable height.

Since the foregoing, which are the more important and interesting of the early balloon ascensions, thousands of others have been made all over the world. In the course of these some utility has developed in the way of military and meteorological observation, but in most cases the immediate purposes and the ultimate results have not been more serious than the catering to an uncertain scientific interest and an unflinching willingness of

the crowd to pay its money for the spectacle of a parachute jump. However, despite the extreme and often unnecessary risks that have been taken by the ignorant or reckless, an examination of the statistics of ballooning discloses a surprisingly small number of fatalities in proportion to the number of ascensions that have been made.

The history of ballooning has been from the first closely associated with warfare. Indeed, it is said that one of the avowed purposes of the Montgolfiers was to render more effective the siege of Gibraltar, by the combined French and Spanish forces, who, however, gave up the fight some time before the Montgolfiers proved the practicability of the balloon. Subsequently a regular "aerostatic corps" was attached to the French army, and did service during the French Revolution and Napoleon's Egyptian campaign. Considerable utility was demonstrated during the battle of Fleurus, in the course of which two aerial reconnaissances from a captive balloon contributed materially to the victory of the French over the Austrians. But when a balloon sent up in honor of his coronation was wrecked against a statue of Nero, the great Corsican seems to have lost interest in the new invention.

Some use of balloons was made by both sides in the American Civil War, and in the Spanish-American war a balloon was successfully employed to discover the presence of Cervera's fleet in Santiago harbor, but by far the most important use ever

made of balloons was in the siege of Paris, during the Franco-Prussian war in 1870. In this remarkable application seventy-three postal balloons were built and sent out from the beleaguered city with cargoes of mail, and carrier pigeons which were used to bring back replies to the messages. In this way over 3,000,000 letters were transmitted, those brought back by the pigeons being reduced so small by photography that 5,000 separate missives weighed only nine grains.

One of the longest balloon voyages on record—not exceeded until within comparatively recent years—was that of John Wise from St. Louis to Henderson, N. Y., in July 1859. This journey was accomplished in a lively gale, with the result that the distance of 950 miles was covered in nineteen hours. October 9-11, 1900, Count Henry de la Vaulx and Count Castillion de Saint Victor superseded the Wise record by a journey from Vincennes, France, to Korostichev, Russia, a distance of 1,139 miles, in thirty-five hours and forty-five minutes.

The present balloon duration record is held by Lieutenant-Colonel Schaeck, of the Swiss Aero Club, who in the balloon *Helvetia*, sent up from Berlin on October 11, 1909, remained in the air seventy-two hours, finally landing in the sea off the coast of Norway.

The balloon altitude record was long credited to Glaisher and Coxwell, who on September 3, 1862, reached a height claimed to have been 36,090 feet. Some discredit has been cast upon the achievement

by doubt concerning the possibility of sustaining life at such a height without carrying a supply of artificial oxygen, with the result that the maximum altitude is now believed to have been not over 29,520 feet. On December 4, 1894, Professors Berson and Gross ascended from Berlin and definitely recorded an altitude of 28,750 feet. Subsequently, on July 31, 1901, Berson and Süring, of the "*Berlin Verein für Luftschiffahrt*", reached a height of 35,400 feet, using oxygen tanks.

So-called "sounding balloons", for meteorological investigation, but without passengers and carrying only self-registering instruments, have reached much greater heights, the record being held by the balloon which was sent up from the Uccle Observatory in Belgium (see Page 44).

SPHERICAL TYPES

The simplest and in some respects the most advantageous form of balloon is the spherical, because a given surface of envelope will enclose a greater volume in the form of a sphere than in any other shape. Furthermore, since a sphere is the form into which any flexible hollow structure tends to distort under the influence of an interior pressure, a sphere is, therefore, the only form not subject to distortion stresses.

In the construction of spherical balloons, the plan usually followed is to cut the material into narrow, double-tapered gores, laid out as shown in Figure 3. These gores when sewn together along their adjacent edges afford a practically

perfect approximation to the required form, as is indicated at *a*, *b*, *c*, and *d*, Figure 3. The correct

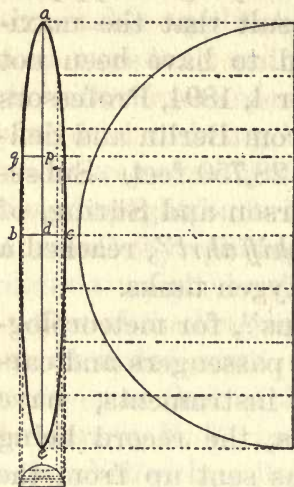

FIGURE 3.—Layout of Gores for Spherical Balloon. The dimension *a e* is one-half of the circumference of the balloon and the dimension *b c* is the circumference divided by the number of gores it is intended to use. These major dimensions settled upon, intermediate points on the gore curve, as at *q*, will be found as shown at the junctures of lines projected from similar points on the diameters of the large and small semicircles.

shape of the gores is found by laying them out as shown in Figure 3.

Practically all non-dirigible balloons are now made spherical—sometimes modified into a pear-shape to provide the open neck commonly used to allow for expansion and contraction of the gas. Except from the standpoint of dirigibility there are few advantages and many positive disadvantages in all but the spherical form. One of the most serious of these disadvantages is the necessity for some sort of rigid or semi-rigid construction to protect non-spherical structures against dangerous distortion.

structures against dangerous distortion.

DIRIGIBLE BALLOONS

Naturally in the development of the balloon it was early attempted to navigate definite courses from one point to another, either in calm weather or independent of the direction of the winds. It was soon seen to be manifestly impos-

sible, though, to derive propulsion from the wind except directly before the wind, anything analogous to the tacking of a ship being out of the question because of the lack of any fulcrum such as is provided by the hull of a ship in the water. This compelled recourse to various systems of internal power development and application, commencing with the hand-manipulated oars and sails of early investigators and coming down to the engines and propellers of modern dirigibles.

Another obvious line of improvement along which much work has been done consists in the reduction of the head resistances against which it is necessary to propel a balloon, reduction of these resistances being the ideal held in view in the construction of the many cylindrical, cigar-shaped, and other elongated and pointed gas bags with which the modern student of this subject is familiar.

So far, however, all successes achieved with dirigible balloons have been more spectacular than practical, and there is little reason for expecting that results of more serious value are in any present prospect of attainment. Certainly, admitting the possibility of an exceedingly limited and precarious utility for the dirigible in warfare, it is, in the opinion of those best qualified to judge, most unlikely ever to assume the least importance as a means of travel.

The great difficulties with the balloon are its inescapably enormous volume and its strict limita-

tions in weight of structure. To ascend, a balloon must be lighter than the volume of air it displaces and, the weight of a given volume of air being fixed and unchangeable, no possible discovery or invention (unless of some structural materials of altogether ultra-terrestrial strength) can open a way of escape from this inexorable factor of the problem. A sphere of air ten feet in diameter weighs almost exactly seventy-six pounds, while a similar sphere of hydrogen weighs something less than six pounds. Consequently, enclosing the hydrogen in an envelope and causing it to occupy the space of an equivalent volume of air manifestly affords a gross lifting capacity within this considerable bulk of seventy-six minus six—only seventy pounds. Evidently the unlikely discovery of some gas lighter than hydrogen can effect no material benefit, for even should it become feasible to encase a vacuum of the requisite size, as some enthusiasts have hoped, this could help the sustentation only to the extent of the eliminated six pounds of hydrogen. And always within whatever lifting capacity there may be provided must come not only the loads that it is required to convey, but also the weight of the structure and the enveloping material, which it is highly desirable to have far stronger and rigider than the strongest and rigidest ever likely to be attainable.

From all of which it follows that the best of balloons are, and are likely to continue, hopelessly bulky and fearfully flimsy, and of only the very

smallest lifting capacities in proportion to their size. Held captive or let drift with the wind, they can be made to afford fair security with very limited utility. Provided with motors and propelling means, they not only oppose the resistance of enormous areas to rapid motion, but also prove of such fragility that their structure must inevitably collapse under the heavy stresses, should sufficient power within the weight limit ever become available to drive them greatly faster than the maximums of twenty-five or thirty miles an hour that have been so far attained, and which are nowhere near sufficient to combat ordinary adverse winds.

The cost of gas alone for each filling of a large balloon at present places it utterly out of the question for performing commercial service at reasonable cost. About a thousand dollars worth of gas on the basis of the most economical production possible (see Page 99) is required for each inflation of a Zeppelin balloon, 443 feet long and 42 feet in diameter, but possessed of a reserve carrying capacity of only five and a half tons. Moreover, no balloon builder as yet has been able within the weight limitation to devise an envelope capable of retaining a filling of gas for more than a limited period (see Page 74)—not to consider the further loss that occurs in the necessary trimming of the craft to desired heights by alternate discharges of gas and ballast—the latter of which, by the way, is a burden to be reckoned with in all estimates of passenger and cargo-carrying capacities.

HISTORY

One of the earliest well studied attempts to produce a successful dirigible balloon was made by Henri Giffard, in France, in 1852. In Giffard's

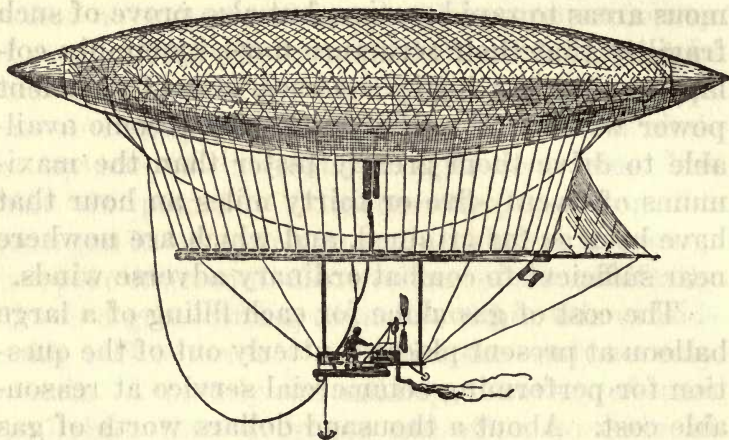

FIGURE 4.—Giffard's Dirigible Balloon. Propelled by 3-horsepower steam engine, weighing, with fuel and water for one hour, 462 pounds. Length 144 feet, diameter 39 feet, capacity 88,300 cubic feet. Made 7 miles an hour in 1852.

machine, illustrated in Figure 4, the gas bag was spindle-shaped, 144 feet long. Though the motor proved very weak it was found possible in very quiet air to steer and to travel in circles, with a maximum speed of scarcely seven miles an hour.

In 1870 another French experimenter, Dupuy de Lome, at Vincennes, tried out a machine provided with an enormous two-bladed propeller, 29 feet 6 inches in diameter. This propeller was turned slowly by the muscular efforts of the eight passengers and, in a breeze of about twenty-six miles an hour, "a deviation of twelve degrees"

from a normal straight drifting course was obtained.

At Grenelle, France, in 1884, Gaston and Albert Tissandier maneuvered for two and a half hours in the dirigible illustrated in Figure 5. This was driven by a one and one-third horsepower Siemens electric motor, weighing 121 pounds and taking current from a bichromate battery weighing 496

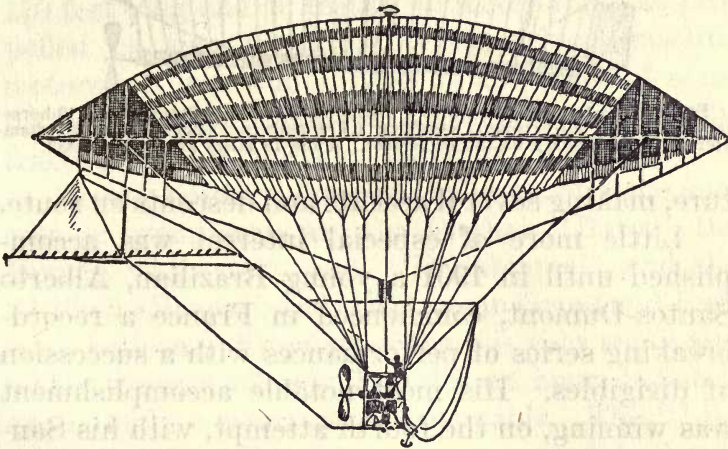

FIGURE 5.—Tissandier's Dirigible Balloon. Propelled by $1\frac{1}{2}$ -horsepower electric motor and primary battery, weighing 616 pounds. Length 92 feet, diameter 30 feet, capacity 37,440 cubic feet. Made 7 miles an hour in 1884.

pounds. The propeller was two-bladed, nine feet in diameter. In a wind of eight miles an hour and with a horsepower output estimated to have run as high as one and a half, a large semicircle was successfully described, following which, in a wind of seven miles an hour, headway was made across the wind and various evolutions performed above the Grenelle observatory.

Following the Tissandier experiments, Commandant Renard of the balloon corps of the French army, on September 23, 1885, navigated from Chalais-Meudon to Paris against a light wind and returned with little difficulty to the point of depar-

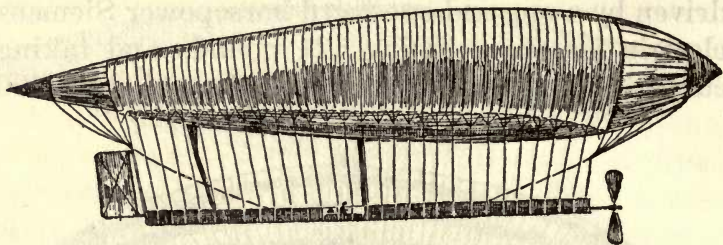

FIGURE 6.—Renard and Krebs's Dirigible Balloon. Propelled by 9-horsepower electric power plant, weighing 1,174 pounds. Length 165 feet, diameter 27 feet, capacity 65,836 cubic feet. Made 14 miles an hour in 1885.

ture, making several ascents and descents en route.

Little more of especial interest was accomplished until in 1901 a young Brazilian, Alberto Santos-Dumont, commenced in France a record-breaking series of performances with a succession of dirigibles. His most notable accomplishment was winning, on the fourth attempt, with his Santos-Dumont No. 6, the M. Deutsch prize of about \$15,000 on October 9, 1901, for traveling from the Parc d'Aerostation at St. Cloud to and around the Eiffel tower and back. His time was about thirty minutes for the distance of nine miles. The balloon, which was the sixth dirigible built by Santos-Dumont, was 108 feet long and 20 feet in diameter, and was propelled by a 16-horsepower gasoline automobile engine. Subsequent to this Santos Dumont built at least six more dirigibles.

The Lebaudy brothers, in 1903, built a dirigible

185 feet long and 32 feet in diameter which, with a 40-horsepower gasoline motor, is said to have attained a speed of 24 miles an hour.

In England the most successful early dirigibles were those of Spencer, Beedle, and Dr. Barton. The first of these was 93 feet long and 24 feet in diameter, with a 24-horsepower motor. The Beedle balloon was of the same proportions, but had only a 12-horsepower motor. Dr. Barton's balloon was 170 feet long and 40 feet in diameter and was propelled by two separate 50-horsepower gasoline motors. It was complicated by an excess of aeroplane stabilizing surfaces that undoubtedly subtracted from, rather than added to, its utility.

Recent military dirigible balloons of some success or prominence are the English "Baby", the French "Liberté" and "Republique", and the "Ville de Nancy", and the German Gross and Parseval balloons. The first of these is very small and makes a speed of only 7 miles an hour, but it is exceedingly convenient and portable. The "Liberté" and the "Republique" are up-to-date developments of the Lebaudy type, and the "Ville de Nancy", illustrated in Figure 18, is a Clement-Bayard product designed for the Russian army. The latter airship, which is 180 feet long and 33 feet in diameter, with a capacity of 180,000 cubic feet, is provided with an internal balloon or balloonet, of the type illustrated in Figure 13, by which the main gas bag is kept constantly distended under an internal pressure of a little over seven pounds to a square foot. This balloon made its first ascent

on June 27, 1909, and subsequently, on June 28 and July 2, it twice remained five hours in the air. Late in August, 1909, it was badly damaged by an inadvertent descent into the Seine, occasioned by a heavy wind coming up while it was at a height of 4,000 feet. On September 25, 1909, the "Republique" exploded at a height of 500 feet, near Paris, and fell to the ground, causing the death of four French army officers.

The latest Gross dirigible has a capacity of 270,000 cubic feet and is propelled by two motors with a total output of 75 horsepower, driving two propellers. Twin ballonets are used to keep the envelope taut, and journeys of over fifteen hours' duration have been accomplished.

On May 22, 1909, a race was held near Berlin between the "Gross II" and the "Parseval II", which is of similar construction. The contest was a tie, with a time of fifteen minutes for a circuit over the Templehof parade grounds.

A very curious small dirigible, designed by Isaburo Yamada, was used by the Japanese army during the siege of Port Arthur. This balloon, which was 110 feet long, differed from all other dirigibles in that the 50-horsepower gasoline motor was in a separate car, much below and in advance of the car proper, to reduce the danger of fire.

A dirigible that has been much in the public eye is the "America", designed by Melvin Vainman and Louis Godard for use in the polar exploration project promoted by Walter Wellman. This

balloon, details of which are illustrated in Figures 12, 19, and 20, is 184 feet long and 52 feet in diameter, with a capacity of 258,500 cubic feet of gas. The total ascensional force at sea level is 19,000 pounds, the weight of the envelope 3,600 pounds, and that of the car, motors, and full tanks of fuel 4,500 pounds. Propulsion is by two bevel-gear-driven steel propellers, 11 feet in diameter, revolved by a 70-80-horsepower Lorraine-Dietrich motor. An 80-horsepower Antoinette motor with a duplicate pair of propellers is kept in reserve. Despite the expenditure of large sums of money and attempts made season after season, the nearest this balloon has come to reaching the pole has been a thirty-mile flight from its base in Spitzbergen.

In the United States little has been done toward the development of dirigible balloons, such activity as there has been being confined to the more or less perfect copying of the best foreign constructions. Knabenshue, Baldwin, and Stevens have been the most successful among the American dirigible balloon navigators.

In every way the most interesting and most important devices in this field of aerial navigation are the great dirigibles of Count Zeppelin, which unquestionably are so far in advance of other constructions of the same general character that their points of merit constitute a fair measure of all dirigible practicability, while their more serious shortcomings are reasonably to be regarded as among the defects of all possible craft of the lighter-than-air type.

In his work Zeppelin appears particularly to have sought the attainment of the utmost possible length in proportion to diameter, with a view to keeping down head resistance while at the same time securing lifting capacity. This in turn has compelled recourse to a rigid structure for the gas bag as the only possible means of keeping one of such length in shape.

Safety has been provided by a multiplication of lifting units, there being seventeen separate and independent balloons enclosed between partitions in the structure. Great lifting capacity is secured by sheer size, while height control is in large measure attained by the provision of fin and rudder-like stabilizing or balancing surfaces.

The partially-sectioned illustration in Figure 17 affords an excellent idea of the construction of all the Zeppelins, of which several have been built. The first of these were commenced in the late nineties at Friedrichshafen, on Lake Constance, where there was built a mammoth floating balloon house, 500 feet long, 80 feet wide, and 70 feet high, mounted on ninety-five pontoons. This house, being anchored only at its forward end, was free to swing so as always to face the wind, with the result that the balloon could be taken out and housed without danger of collision.

The first Zeppelin balloon was 410 feet long and 39 feet in diameter, with its framing made up of sixteen twenty-four-sided polygonal rings, separated by spaces of 26 feet. The rings, stays and even the wire bracing were at first made of "wol-

framinium" (see Page 385), but in subsequent models it is said that this metal has been by degrees given up, until in balloons now building for the German government it is almost entirely replaced with wood and steel.

Over the framing and between the chambers ramie netting was liberally applied, reinforcing both structure and fabric. The nose of the balloon was capped with a sheet-aluminum bow plate.

The compartments, which in the first model contained a total of 351,150 cubic feet of hydrogen, affording a total lift of eleven tons, are lined with rather lighter balloon fabric than is necessary for non-rigid dirigibles, and this fabric is proofed with the gray quality of rubber which affords the highest resistance to the leakage of gas. Over the outside of the framing a non-gasproof fabric is used. A space of about two feet is provided all around the internal balloons, under this external cover, to serve as a protection from the heat of the sun.

Two boat-like cars, at the ends of a stiffening keel of latticed framework, are provided on the underside of the cylindrical body, and are sufficient to float the whole craft on the water. These cars, each 21.32 by 5.96 by 3.28 feet, are connected by a passageway 326 feet long and from one to the other a cable is stretched, along which a sliding weight can be adjusted to trim the craft fore and aft. In the first Zeppelin a 15-horsepower Daimler motor—at 700 revolutions a minute—was

located in each car, each motor driving two four-bladed propellers, $3\frac{3}{4}$ feet in diameter.

The speed of the first Zeppelin was not over seventeen miles an hour and only short journeys were attempted, but in later models in which the sizes have been increased materially and as much as 350 horsepower applied through six three or two-bladed propellers, speeds of as high as twenty-five or perhaps thirty miles an hour have been maintained in calm air for distances as great as 950 miles. With the wind the speed is, of course, higher, but, conversely, it is correspondingly lower when the wind is adverse.

Landing with the balloons of the Zeppelin type always has proved precarious, especially when the descent has not been on water. Of the several that have been built, one has been burned and all of the others more or less seriously damaged at different times in coming to the ground.

Nevertheless, at least the German government continues to interest itself in this phase of aeronautics, and at the time this is written is reported to be building dirigibles of the Zeppelin type even larger than any that heretofore have been constructed.

The map in Figure 270 shows the more important of the Zeppelin journeys.

SPHERICAL TYPES

Very few balloons of the true dirigible type have been built with spherical envelopes, the most noteworthy being one of Blanchard's first bal-

loons, which he sought to propel by hand-manipulated wings or oars.

However, all balloons may be said to be in some degree dirigible, even those of ordinary spherical types being capable of a slight degree of control by the manipulation of drag ropes, as is explained on Page 114.

ELONGATED TYPES

As has been previously explained, to reduce head resistances and permit of special strengthening of the bow surfaces, practically all dirigible balloons are given elongated forms, necessitating structural stiffening beyond what is obtainable by mere strength and guying of the envelope alone. There are two principal means of attaining such stiffness as is to be had—one the use of an under-frame or long truss-like car to which the envelope is securely stayed at intervals, and the other the employment of internal strengthening within the gas bag itself. The first of these constructions, which has been termed “semi-rigid” to distinguish it from the second type, is the one used in practically all dirigible balloons except the Zepelin. The latter machine is not only the foremost exponent, but is also practically the sole representative of the “rigid” system, its details being described in Pages 85 to 88, and in Figure 17.

Pointed Ends to reduce air resistance are utilized in most elongated dirigible constructions, but probably have little if any advantage in this

regard over hemispherical ends; besides which they are heavier and less strong.

Rounded Ends, of exact hemispherical shape, are geometrically and mechanically the lightest, simplest, and most stable forms to resist the end pressures in cylindrical envelopes, while, as is suggested in the previous paragraph, there is no ground for supposing that they noticeably increase head resistances—especially at such speeds as have been attained so far.

Sectional Construction, though not altogether new, has been worked out in more detail and is more practically applied in the Zeppelin than in any previous airship. In the great balloons of this type—see Page 96 and Figure 17—the sixteen or seventeen disk-like sections are entirely independent of one another, so that leakage from any one can not affect the others.

The Effect of Size on balloon design is a subject concerning which there is much misunderstanding. It is asserted, for example, that doubling the dimensions of a balloon cubes its capacity while only squaring the areas of its surfaces. This is, of course, perfectly true, but the consequent reasoning that this makes it possible to secure greater proportionate strength with each increase in size seems largely unwarranted. For, to maintain a proportionate strength, it is necessary to double the thickness of the surfacing material with the doubling in size, with the result that the quantity of material used is cubed, after all, just as the capacity is. Even at this, though, the strength

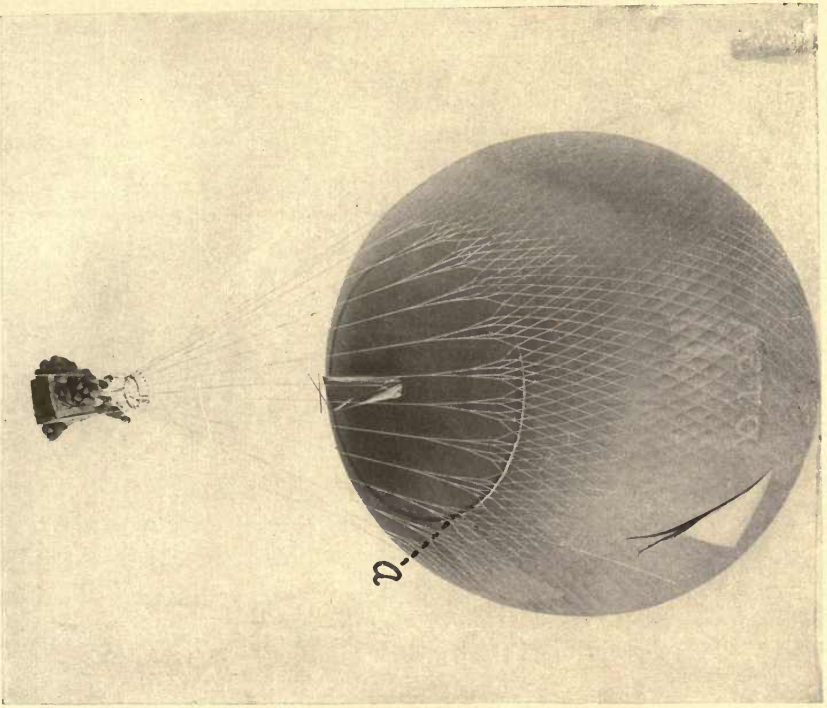

FIGURE 8.—Modern Spherical Balloon. Note the netting covering the whole upper portion of the gas bag, down to the circle *a*, at which point it is worked into the cords that support the basket. While apparently simple, the designing and manufacture of nettings is a complicated process.

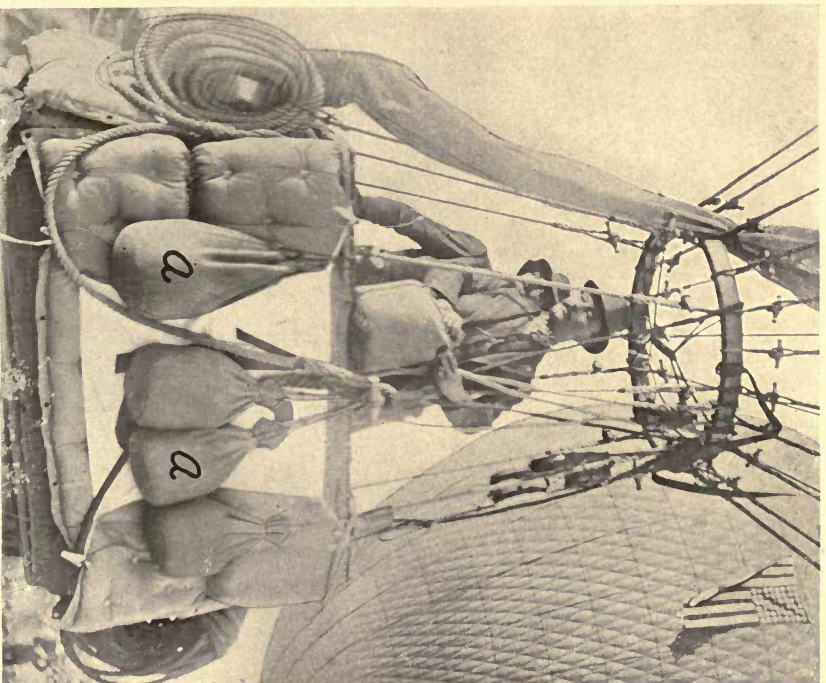

FIGURE 11.—Car of Modern Spherical Balloon—the same shown in Figure 8. The bags *aa* are filled with sand for use as ballast. The netting hoop, or ring, immediately above the aeronauts' heads, is a characteristic feature of nearly all balloons ever built.

possible in a balloon would seem to advance in proportion to increase in its lifting capacity, whereas in an aeroplane there is the unavoidable rapid gain of the weights over the areas. Nevertheless, it remains a safe general rule applicable to all structures, that the smaller the size the greater the proportionate strength with a given weight of material. One distinct advantage that comes from great size is the gain of the lifting capacity over the projected area—the one cubing while the other squares with each increase in size. This feature definitely permits the provision and application of more power per unit of forward resisting surface in large balloons than in small.

ENVELOPE MATERIALS

In the design of balloons, much effort has been put forth to develop the lightest, strongest, and most impervious materials that can be had for envelope construction. In the course of these experiments every art and every country has been ransacked to find new fabrics, varnishes, etc. The result of years of investigation and research, however, has been to settle the superiority of silk, cotton, and linen among the fabrics, and linseed oil and rubber as gas-proofing materials. In the accompanying illustrations and captions, Figure 7, an idea is given of the appearance and characteristics of some typical modern balloon fabrics, made by several of the more prominent manufacturers of these materials.

Naturally, much the same materials that are

suitable for aeroplane surfaces are suitable for balloon envelopes, though if any distinction exists it is that the balloon envelope requires to be most heavy and impervious, while aeroplane surfaces may be very light and need not be absolutely air-proof (see Figure 184).

Large balloons generally require heavier envelopes than small, because of the greater area and consequently greater stresses. An exception to this rule is the case of rigid balloons of the Zep-pelin type, in which, the necessary strength being chiefly afforded by the framing, much lighter covering materials can be used than in the balloons of other types of similar size.

Sheet Metal as a balloon covering probably was first exploited in Lana's ingenious plan of the copper-covered vacuum (see Page 67). Since then it has not progressed notably in practical application to the purpose in view, though it is perennially reinvented on paper by persons whose zeal to achieve is greater than their technical equipment. Excellent rubber-coated balloon fabrics are to be had weighing no more than six ounces to the square yard, and with a tensile strength of 100 pounds to each inch of width. Sheet aluminum of the same weight would be only $\frac{3}{1000}$ -inch thick, would have a tensile strength of not over eighty pounds to each inch of width, and would crack and leak with the slightest straining or denting—not to consider the impossibility of fastening the sheets to the framing and one another without creating holes and bad joints beyond toleration.

Using steel, which is only three times as heavy as aluminum and ten times as strong, the plates would be $\frac{1}{1000}$ -inch thick and would sustain 200 pounds to each inch of width, but the difficulties of construction, maintenance, and adequate protection from rust would be all but insuperable.

Silk possesses the superiority over cotton that it does not rot as readily, while it is materially stronger under direct tensile stresses, though it is not nearly as capable of withstanding repeated flexing. Some of the modern single and multi-coated rubberized silks are most beautiful and serviceable fabrics, and by many are regarded as the highest quality of all balloon materials. The best silk balloon fabrics come twenty-seven inches wide and at present retail for from \$2.00 to \$3.50 a yard. An objection to silk is its electrostatic properties, rendering the possibility of discharges sufficient to ignite the gas much more likely when it is used than is the case with cotton and linen.

Cotton, in its best qualities (the sea-island and Egyptian), is one of the strongest and most durable of all fabrics, as is particularly evidenced in its exclusive use in pneumatic tires, in which the stresses to which it is subjected are literally terrific. It is, however, very subject to weakening from the action of moisture, the least rotting affecting it most adversely. In the form of muslins and percales it is very strong and inexpensive, but care must be taken to secure the best grades of closely-woven, unsized, and unbleached goods, if superior results are to be secured. Impregnated with suit-

able materials, it is readily made fairly impervious to gases and insusceptible to weather. The best rubberized cotton balloon fabrics come from thirty-six to forty inches wide, and cost from 90 cents to \$1.50 a square yard.

Linen threads and fabrics are almost as strong as silk and cotton, the long fiber making an ordinary linen thread or cord stronger than any but the finest sea-island cottons. In durability under flexing it is superior to silk, though not as good as the best cotton. In its resistance to deterioration from water, it finds place between cotton and silk, being superior to the former and inferior to the latter.

Miscellaneous Envelope Materials are used to some extent, but the best of these are combinations of materials already discussed. Thus some high grade balloon fabrics consist of a layer of rubber faced on one side with silk and on the other with cotton, the idea being to combine the advantages of both materials. Several plies of different weights and materials can be superimposed in this manner. Ramie, jute, manila, and other fabric materials do not possess the advantages of commoner goods.

Paper—the jute manilas, banknote, and parchment papers, and the tough papers that are used in Japan for clothing—has been tried with success in balloon manufacture, as is, indeed, evident in the early work of the Montgolfiers and in modern fire balloons. Paper has the merit of extreme

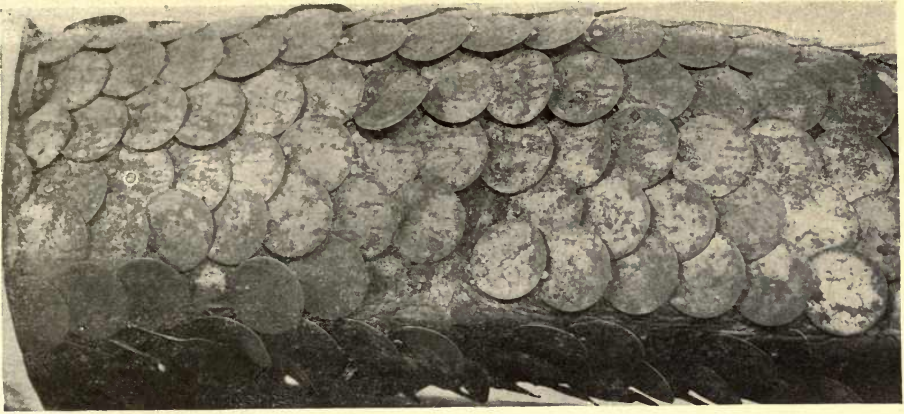

FIGURE 12.—Curious Drag Rope of Wellman Dirigible.

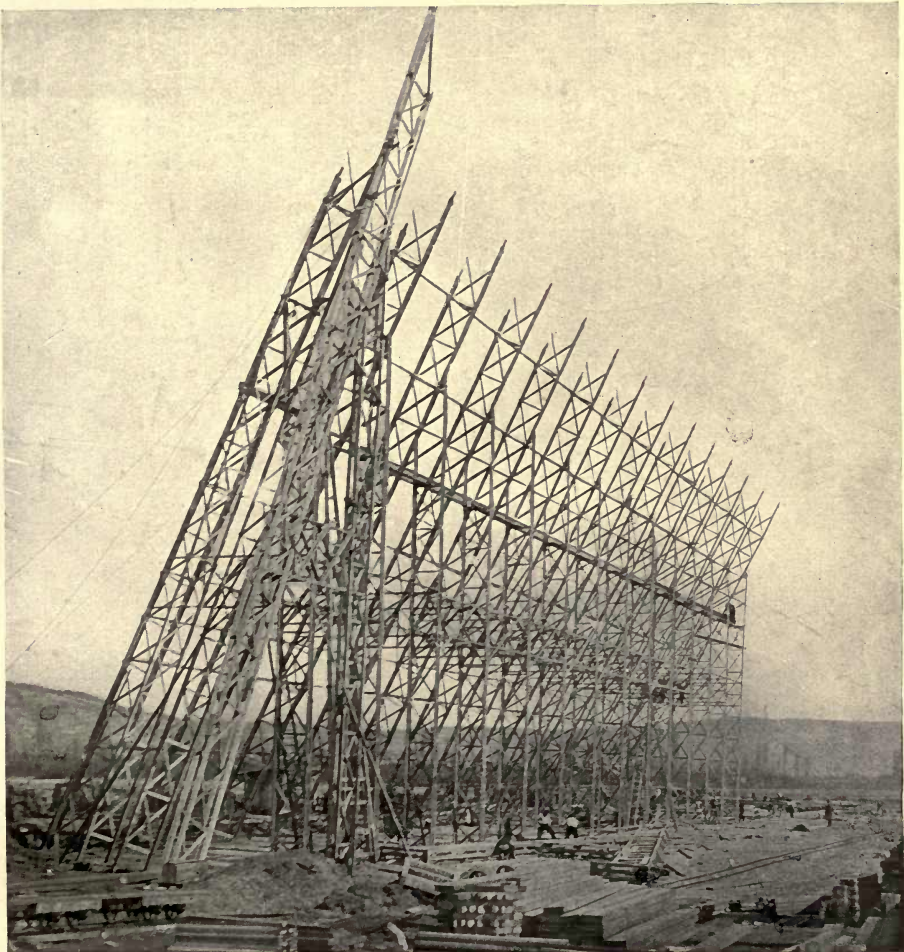

FIGURE 14.—Balloon House for the Dirigible "Russie" in Course of Construction.

cheapness and a considerable imperviousness, but is not durable.

Goldbeater's skin, from the caecum of the ox, has been used to some extent for model and "sounding" balloons, and is exceedingly light, strong, and impervious. Its great cost, the difficulty of strongly joining the many small pieces, and its susceptibility to moisture have prevented its extensive use.

Coating Materials that are suitable for gas-proofing balloon envelopes are very few in number.

Vulcanized rubber undoubtedly is the most impervious and is an excellent protection to the fabric, but it oxidizes and cracks with age. Red rubber coatings offer a maximum resistance to oxidization from the sun's rays, while gray rubber inner linings are found most impervious to gases.

Linseed oil varnishes are cheap, slightly lighter than rubber, and easily reapplied as leaks appear, but tend to be sticky, especially when newly applied or in warm weather, usually requiring liberal dustings of powdered talc, soapstone, or chalk to keep a folded balloon envelope from sticking together. Besides this they are rather susceptible to the action of rain and mist.

Gutta percha, dissolved in benzine, has merits in the way of lightness and cleanliness but is rather pervious unless heavily applied, besides which it may crack under repeated folding.

In addition to the foregoing well known materials there are various balloon varnishes the com-

positions of which are kept secret by the manufacturers, but most of which are of very fair quality. Indeed, to so exact a science has the manufacture of balloon envelopes been reduced, the best envelope materials on the market are now guaranteed when new not to permit the escape of gas faster than at some stated rate—ten liters to the square meter per twenty-four hours, under thirty millimeters of water pressure, being the guaranteed maximum for double sheetings of the qualities illustrated in Figure 7. Reduced to English equivalents this is not quite $\frac{3}{10}$ cubic foot of gas per square yard per twenty-four hours, under a pressure of $6\frac{1}{7}$ pounds to the square foot. In the case of a dirigible like the largest Zeppelin, with a surface of about 6,300 square yards and a capacity of about 536,000 cubic feet, this means a loss of only 2,000 cubic feet of gas a day.

In joining rubberized envelope materials, the breadths are lapped an inch or less, given three successive coats of rubber cement, each of which is allowed to dry, and are then rolled tightly together with a metal roller. This done, the seams are sewed and after sewing covered with adhesive strips of joining material, coated with sticky, unvulcanized rubber, which also are rolled down hard with a metal roller.

INFLATION

Inflation materials for balloons present little variety and few possibilities of improvement. Obviously the range is limited to such gases as

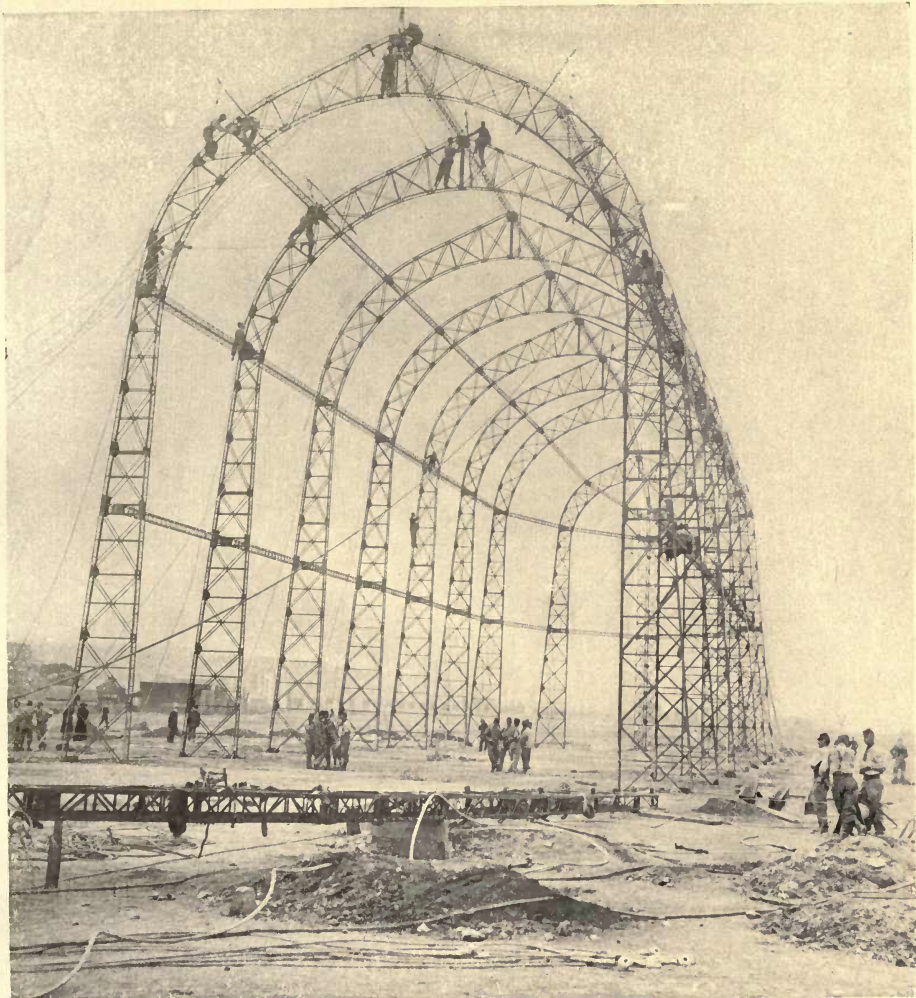

FIGURE 15.—Portable Balloon House Used by the French Army. This immense structure is built in easily assembled and dismantled units, so that it can be hauled to a desired point by wagon train and quickly set up. Note the arch on the ground, awaiting erection.

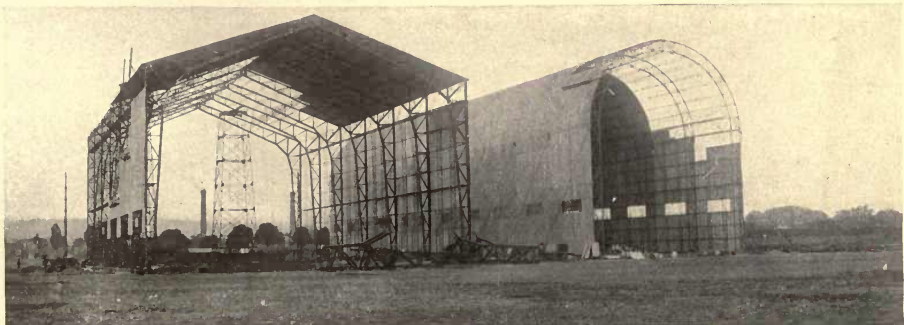

FIGURE 16.—Balloon Houses Nearing Completion.

are lighter than air, with reasonable preference for the lightest, though considerations of cost, availability, and safety are not ordinarily to be disregarded.

Heated Air, as has been explained, was one of the first substances used for balloon inflation. Air expands about $\frac{51}{2500}$ of its volume for each degree Fahrenheit increases in temperature, so heating from 60° F. to 150° F.—for example—will increase the volume occupied by one pound from about 13.1 cubic feet to 22.7 cubic feet, making the contents of a balloon subjected to this rise in temperature only $\frac{131}{227}$ as heavy as the external air, with the result of securing an ascensional force of approximately $\frac{1}{31}$ pound for each cubic foot of contents. Of course, no matter what the initial expansion given the air it rapidly cools with removal of the source of heat, so to maintain a hot-air balloon in the air for any period of time requires that there be carried along some means of continued heating (see Page 70). Because the balloons built by the Montgolfiers were of the heated-air type, such balloons are often called “montgolfieres.”

In heating the air in practical ballooning it is not now attempted to do this otherwise than on the ground, before the start, as hot-air balloons are chiefly used for brief ascensions—exhibitions, parachute jumps, etc.—longer balloon voyages generally being made with gas craft. The chief essentials of a heating plant are cheapness or portability, and a capacity for producing quick inflation.

The simplest and at the same time most practical and efficient methods for inflating modern heated-air balloons involve little more than digging a trench in the ground, covering this, and then connecting it with the balloon, which is suspended or partially suspended from a pole erected near one end of the trench. A hot fire is maintained in the end of the trench farthest from the balloon by repeated supplies of light solid fuels, or by dashes of gasoline thrown with a cup. Sufficient draft must be provided to insure flow of the heated-air through the trench and into the neck of the balloon.

Hydrogen is the lightest of all known substances, one cubic foot of this gas at 32° F. and at atmospheric pressure weighing only .005592 pound, against .080728 pound for an equal volume of air under the same conditions of temperature and pressure. Hydrogen is very combustible, burning readily in the presence of air or oxygen, the product of the combustion being water (hydrogen monoxid). Mixed with air in proper proportions it forms violently explosive mixtures. Though one of the most abundant of all the elements, it rarely is found except in combination with other elements. It was first isolated by Cavendish in 1766.

Hydrogen is readily prepared by the decomposition of water or steam, electrolytically or otherwise, and by the action of dilute sulphuric acid upon zinc or iron, the latter reaction being still much used for the production of this gas for the

inflation of balloons. It is a chief constituent of all the common fuel and illuminating gases.

A modern process for producing hydrogen—a process that is coming into considerable use for the inflation of military dirigibles in continental Europe—is that of Dellwik-Fleischer for rapidly and inexpensively manufacturing very pure hydrogen by the reactions that ensue when steam is passed through a spongy mass of iron ore, previously partially reduced to metallic iron by the action of water gas. The process virtually may be said to be divided into four stages—the first two in alternation having to do with the rapid and economic production of the necessary water gas and the second two in alternation affording the hydrogen.

Beginning with the manufacture of the water gas—a tall cylinder is filled with coke through which heated air is passed for about a minute, causing sufficient combustion to produce a high temperature; then the air is shut off and steam is passed through the coke for about half an hour—until the temperature is so lowered that reheating must be effected by the air blast—during which time the water gas is produced from decomposition of the steam by the coke and admixture with the resulting hydrogen of a practically equal quantity of carbon monoxid formed in the process. Small quantities of carbon dioxid, sulphuretted hydrogen, etc., which also appear, are removed before the final two stages of the process.

These final stages, which produce the hydrogen,

involve the use of a tall retort filled with hematite or magnetic iron ore, or with a mixture of the two, and surrounded by a furnace capable of maintaining the retort at a temperature of about 1,470° F. The first stage consists in passing through the retort enough water gas to reduce the ore to spongy iron—the action being stopped at a point dictated by experience, and considerably short of complete reduction. The final stage consists in stopping the supply of water gas and substituting for it a flow of steam, which the spongy mass of highly-heated metal decomposes into its elements, hydrogen and oxygen, the first being collected and the second forming with the iron a mass of ferric oxid which can be again reduced by the use of water gas.

Since the raw materials required—coke, iron ore, and water—all are very cheap, and both the water gas and hydrogen are produced intermittently, the process lends itself readily to economical working and to the use of simple and reasonably portable apparatus, the latter involving little more than the cylinder for the coke, the retort and furnace for the iron ore, a boiler to supply the steam, and a small gasometer to contain the water gas. No special fuel is required for the retort-heating furnace, the water gas coming through the iron ore without a sufficient loss of combustible elements to preclude its use as a source of heat for this purpose.

The hydrogen produced by this process is exceptionally pure—98½%—containing only a small

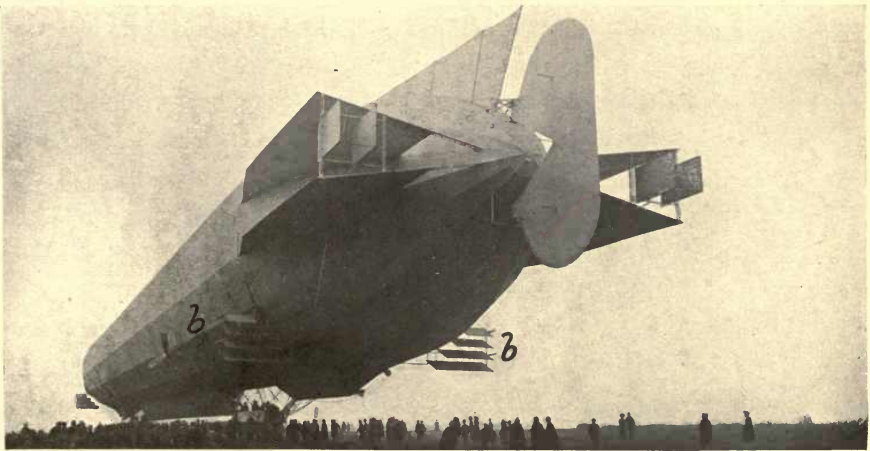
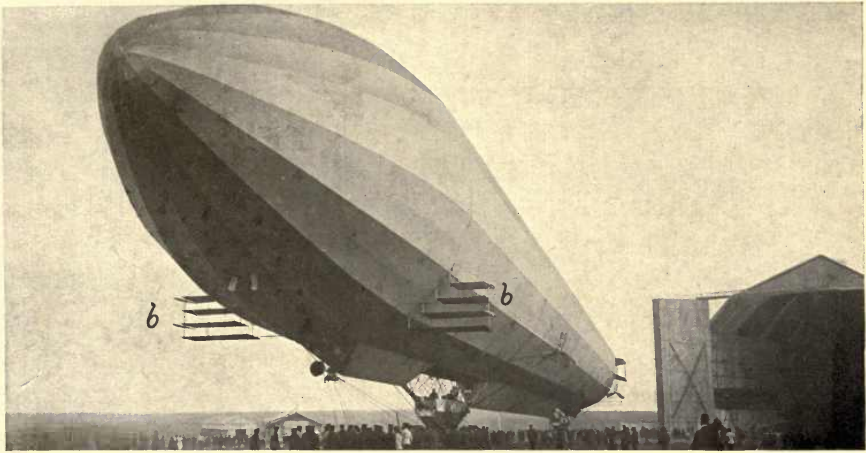
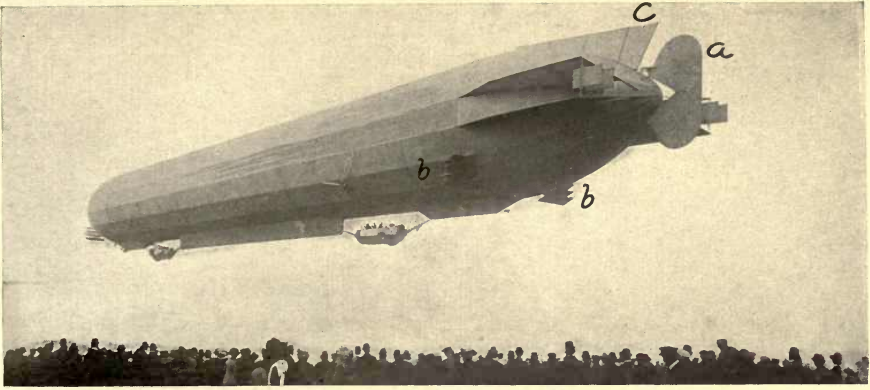

FIGURE 17.—The latest Zeppelin Dirigible. The upper picture shows the rigid construction very clearly, while in the different views the stabilizing fins *c*, the dipping planes *bb*, and the rear rudder *a*, are clearly shown.

admixture of atmospheric nitrogen and trifling quantities of other gases.

Illuminating Gases of all the common qualities are lighter than air and therefore are of greater or less theoretical utility for balloon inflation. Practically, however, the only ones available are the common coal and water gases and natural gas—acetylene and olefiant gas being almost as heavy as air, besides very expensive, while the pure methanes, pentanes, etc., are not only difficult to prepare but when prepared present no advantages over the more complex compounds that are to be had by tapping the widely-available commercial mains.

Ordinary coal gas weighs about .03536 pound to the cubic foot, while heavy carbureted hydrogen weighs .04462 pound to the cubic foot. Acetylene weighs .0767 pound to the cubic foot, and olefiant gas weighs .0795 pound to the cubic foot.

Though the majority of commercial illuminating gases are complex and too often very impure compounds, it is a safe generalization that as taken from the mains for balloon use they can be counted upon to afford ascensional forces equal to from nine to seven-sixteenths of the weight of the air displaced.

Most natural gas is fairly pure methane, and is light enough to serve very well for balloon inflation.

Vacuum chambers as means of securing ascensional force are from time to time resuggested by deluded inventors, but since this principle is pos-

sibly the first ever produced for balloon construction, besides which it is as unavailable as it is ancient, it need be mentioned only to be dismissed. All that there is to be said on the subject is pretty thoroughly analyzed in the consideration of friar Lana's copper-plated vacuum, on Page 67.

Miscellaneous inflation possibilities undoubtedly exist in the prospect of new gases to be discovered or in the utilization of ones now known but not employed, but whatever the advantages thus left to be secured it is certain that among them there will not be any material increase in lifting capacity, since hydrogen already affords nearly $\frac{1}{4}$ of all the lift there is to be had, this factor being limited, as has been previously emphasized, not by the lightness of gases, but by the weight of air displaced. However, should helium, which is almost as light as hydrogen (11 units of lifting capacity against 12 with hydrogen), ever be commercially produced in quantity it is possible that it would be of advantage to use it because of its chemical inertness, which in general as well as military uses certainly would contrast favorably with the dangerous inflammability of hydrogen. At the present time practically all the isolated helium in the world is the quantity of about 14½ cubic feet in the possession of the University of Leyden. Ammonia gas, which is almost as light as some illuminating gases—.04758 pound to the cubic foot—might appear to have some possible application to the inflation of balloons designed to be proof against incendiary projectiles. Its cost,

difficulty of preparation with present portable facilities, its extremely irritating effect when respired, even in very small quantities, and its deleterious action on envelope coatings, are among the greatest objections to it.

NETTINGS

Nettings are necessary in all the non-rigid types of balloons to restrain the gas bag to its proper form and to distribute the load of car and cargo uniformly over it. To meet these requirements, cordage of very high strength is usually employed for nettings, knotted into meshes varying with the size of balloon, the weight supported, and the strength of the fabric, but always sufficiently close to insure uniform distribution of the stresses and to prevent serious accident from local breakages. Very often the nets used are of closer mesh over the upper parts of the gas bags than they are lower down, and they are not usually made to come very much lower than the median line of a balloon, as in Figure 8, in which a typical modern spherical balloon is well illustrated, all of the weight being, of course, sustained upon the upper part. In this illustration, *a* indicates the lower edge of the netting, from which a series of straight cords are used to connect it directly with the car. The large number of these and their practical independence of one another is in the ordinary balloon a chief safeguard against structural disaster.

Balloon nettings are usually knotted exactly the same as common fish nets, preferred forms of

knots employed and the wooden shuttles used for making them being illustrated in Figure 9.

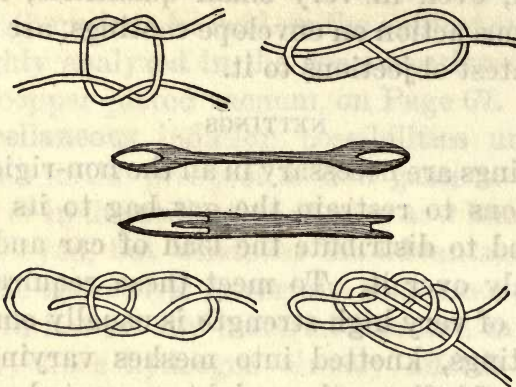

FIGURE 9.—Shuttles for Knotting Balloon Nettings, and some Typical Knots

Decidedly unusual, yet not without some merits, was the use of piano wire in the place of cord supports in the Santos-Dumont dirigible "No. 6" and in the ill-fated Servero balloon (see Page 107). The merit of wire, besides the great strength and lightness, is its small resistance to movement through the air.

CAR CONSTRUCTION

It becomes obvious upon a most casual consideration or investigation of the subject that unending variety of designs and systems of construction are possible in the devising of balloons and balloon cars. This being the case, no attempt is made herein to describe all possible forms, it being enough to note a few general principles that must always prevail, together with some comment on the most-used materials. Natu-

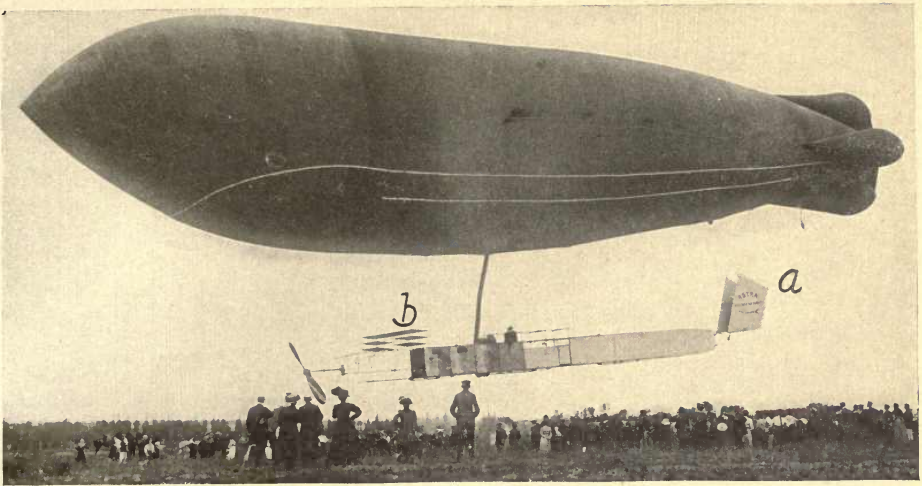

FIGURE 18.—Dirigible Balloon "Ville de Nancy."

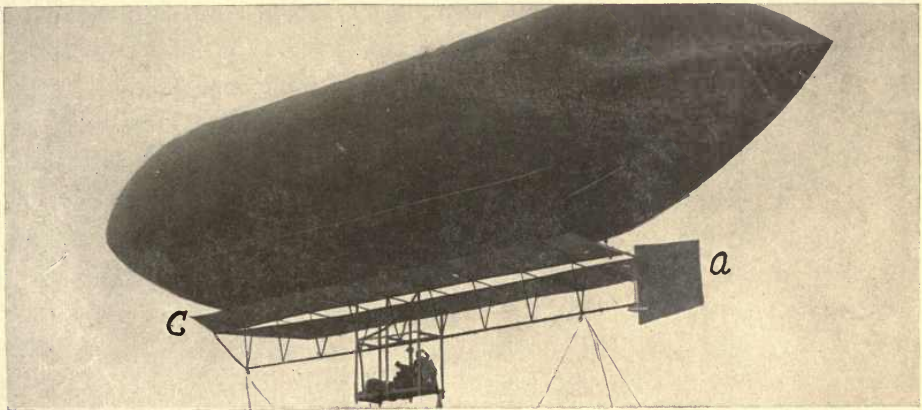

FIGURE 21.—Malicot Semi-Rigid Dirigible Balloon.

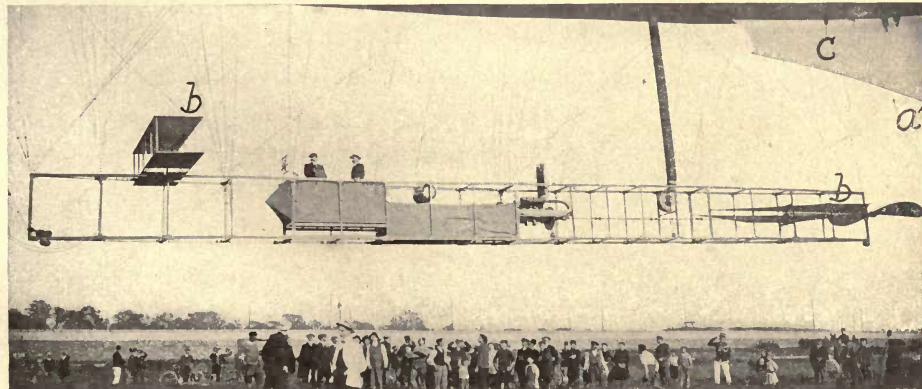

FIGURE 22.—Nacelle of the French Dirigible "Zodiac III."

rally, the conservative and well informed investigator will be largely influenced by even though he may not closely follow the constructions of others who have pioneered this field. Many of these constructions are described or illustrated herein in connection with the descriptions of the balloons to which they pertain. It may be to the point, however, here to call attention to the fact that dirigible balloon cars, besides serving primarily for the accommodation of passengers must also often serve as mounting and bracing for motor and propelling means, and, in the case of semi-rigid dirigibles, as stiffening members for preserving the shape of the gas bag.

Rattans of the kinds commonly employed in wicker and basket work have found extensive use in the manufacture of ordinary balloon cars, to the construction of which they are eminently adapted by reason of their lightness, strength, and ease of working. For the more elaborate cars, or "*nacelles*", of dirigibles, they prove less suitable, it being difficult to make such elongated structures as this type generally requires without the use of heavier and stiffer materials.

Wood is the preferred material for building the understructures of modern non-rigid and semi-rigid dirigible balloons, and is coming to be regarded as superior to metal for the framing of balloons of the rigid type, such as the Zeppelin. Of the different woods, bamboo, spruce, etc., are generally regarded as the most suitable (see Chapter 11). The *nacelles* of several typical

dirigibles are shown in considerable detail in Figures 18, 19, 20, 21, and 22. That of the Wellman balloon is largely of steel.

As will be noted from an examination of these illustrations, metal joining members and corner pieces are used in most cases, with diagonal staying with wire.

Miscellaneous schemes and materials of car construction are disclosed from time to time in the design of new dirigibles, and often new details of considerable interest thus appear. Besides the common use of wire diagonals and metal corner members, already referred to, cordage, leather, and rawhide lashings have their special merits and special applications, as is more fully explained in Chapter 11. Covering materials, such as leather, canvas, thin wood, and ordinary balloon-envelope fabrics often are applied to balloon cars to reduce wind resistance, shelter the passengers, or add to appearance.

HEIGHT CONTROL

The control of height is a balloon problem involving a number of well-established factors and admitting of a considerable variety of solutions. The atmosphere varying in its density and consequent sustaining quality with every variation in barometric pressure, whether due to variation in altitude or variation in meteorological conditions, it follows that to navigate a balloon either up or down must involve either a change in the quantity of sustaining gas or in the weight to be sustained,

or must require the application of power to operate against the normal tendency to float at some certain level determined by the interaction of the various factors of barometric pressure, weight, ascensional force, etc.

Non-Lifting Balloons, so-called, are ones in which balance of the weight and ascensional force is provided at the ground level, instead of at some greater height, as is virtually the case with ordinary balloons. This balance accomplished, it has been sought to travel up and down by the supplementary action of one or more propellers revolving in a horizontal plane, the idea being that no matter how slight the propeller thrust it must be sufficient to produce the vertical movement. The fallacy of this reasoning becomes apparent when it is considered that the required initial equilibrium can exist only at some given level and therefore is lost immediately upon ascent or descent to any higher or lower level. As well expect to draw a balloon in equilibrium at a height down to the ground by a propeller as to expect to raise to a height one in equilibrium at the ground. The thing can be done, of course, but its accomplishment loses all practical value in the complication and precariousness of the resulting conditions. It was in a balloon of this type that Auguste Servero and his engineer Sachet lost their lives in France, on May 12, 1902.

Escape Valves of one sort or another, for discharging more or less of the gas, are the time-established means of causing a balloon to descend.

Such valves usually are of very large diameter and are located in the highest part of the gas bag, with control by means of a cord running down within reach of the operator's hand. Originally devised by M. Charles (see Page 71), escape valves have changed but little from the form finally decided upon by him as most satisfactory. One of modern construction is illustrated in Figure 10,

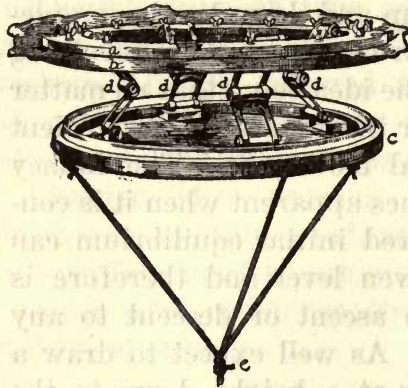

FIGURE 10.—Balloon Valve. The fabric at the top of the gas bag is clamped between the rings *a b*, and the opening through these rings is kept normally closed by the disk *c*, held in place by the pressure of the gas and the tension of the spring hinges *d d d d*, but a pull on the cord *e* serves to open the valve, permitting the escape of any desired quantity of gas.

which a seam running along the side of a balloon can be laid open. The "rip cord" finds its use just at the moment of landing, as a means of quickly collapsing the gas bag before it can be blown about by the wind, or caused to reascend by losing the weight of the passengers.

are clamped, while *c* is a cover to the opening in *a b*, normally held up by the gas pressure and the spring hinges *d d d d*, but arranged to pull down as shown by the rope *e*, when it is desired to permit the escape of gas.

Practically a valve is the "rip cord," by means of

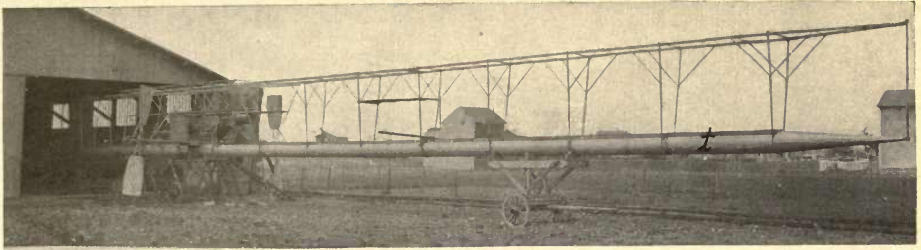

FIGURE 19.—Side View of Nacelle of Wellman Dirigible.

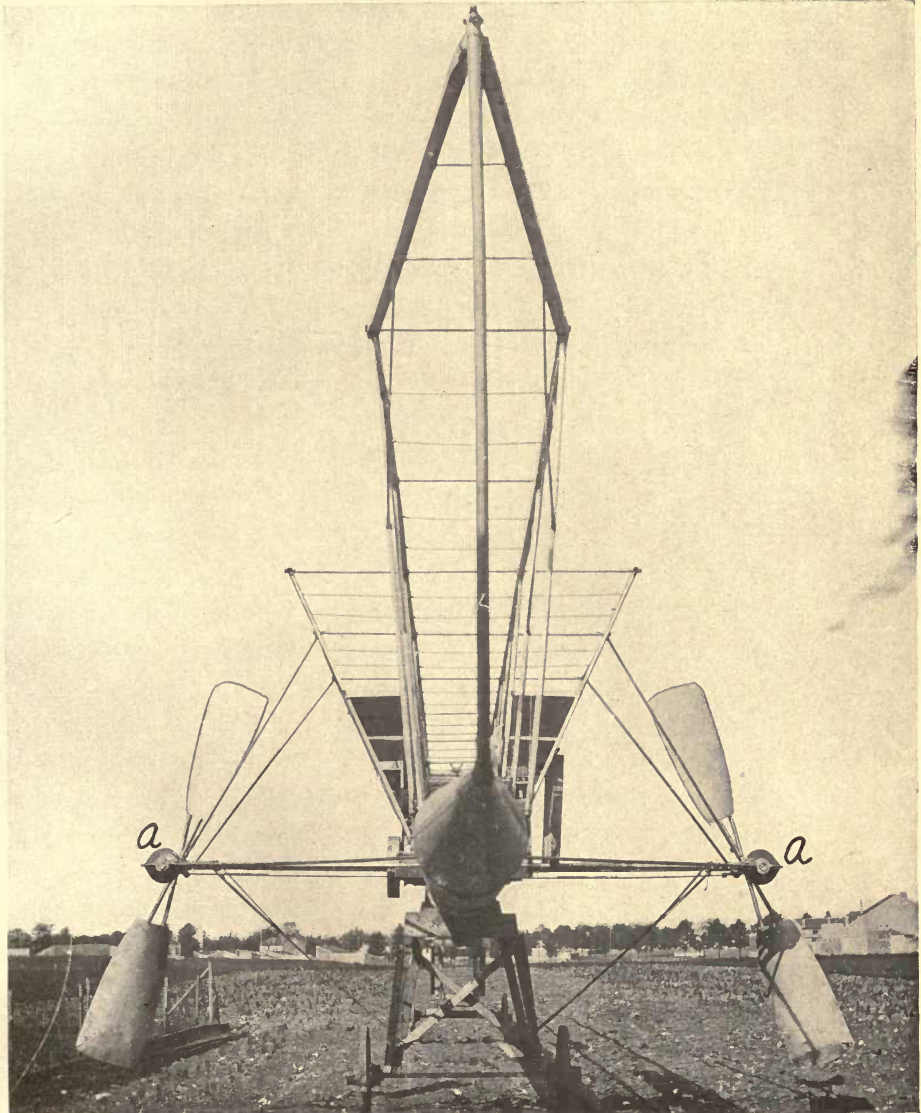

FIGURE 20.—Front View of Nacelle of the Wellman Dirigible. The driving system is well shown in this illustration, from which it is evident that the transmission is one that might readily be applied to an aeroplane. The motor is set crosswise of the car, its prolonged crankshaft driving the twin propellers oppositely by bevel gears contained in the housings *aa*.

Ballast, by the discharge of which ascension can be induced, is another early method of height control, and in alternation with discharge of gas still is found a most effectual means of controlling vertical movement. Fine clean sand is generally preferred as ballast, as calculated to cause the least injury to anything upon which it may fall. Such sand as is commonly used will weigh from 90 to 117 pounds to the cubic foot. Water, which weighs 63.35 pounds to the cubic foot, has been employed, and has the advantage of breaking into imperceptible mist before it falls very far, but the necessity for cans or tanks to contain it is a great objection, since these cannot be cast overboard as carelessly as may be the sacks used to contain sand. Bags of ballast usually are carried hung around the edges of a balloon car, as at *a a*, Figure 11. It has been proposed to carry water in canvas bags.

With a balloon of moderate size the discharge of even a most trifling weight of ballast often produces an astonishing change in height, the dropping of a lead pencil having been observed to cause an ascent of a hundred feet. In emergencies, clothing, instruments, etc., often have been cast away as ballast, and there are instances in the history of ballooning in which the basket itself has been cut loose, the passengers clinging to the netting cords.

Compressed Gas, carried in cylinders and permitted to escape into the balloon and there expand, or drawn out and recompressed, serves to control height in a very scientific manner. Not only is

the sustaining force reduced by the withdrawal of a portion of the gas from the envelope, but this gas compressed serves the purpose of ballast. The chief objections to this system inhere in the weight of the containers required for the compressed gas and in the power necessary for compression.

Drag Ropes can be used in certain circumstances as a sort of recoverable ballast. Thus with a long rope trailing on the ground it is evident that if for any reason the balloon's lifting capacity decreases, as from condensation of moisture upon the envelope, etc., the consequent descent will reduce the weight as more and more of the rope rests upon the ground until a condition of equilibrium is reached. Conversely, should the balloon start to ascend, the increasing weight of rope it picks up must finally stop it. This system works best only with very long or heavy drag ropes and is obviously inapplicable over rough or thickly-populated country. One of the most interesting applications of this principle was that planned for the Wellman dirigible, with which it was planned to seek the North Pole. In this application the drag rope, made of a leather-casing, was filled with provisions and supplies and armored with steel scales to withstand the wear of the continued dragging. The details of its appearance are shown in Figure 12. Unfortunately, it broke on the first attempt to use it, in August, 1909.

Open Necks, or incomplete inflation of balloon envelopes, are necessary to provide for the expansion of the gas that takes place as the balloon

ascends from a level of high barometric pressure to one of lower air pressure, or that results from changes in temperature. With a gas bag completely filled and no provision for the gas to escape, this tendency to expand will cause a bursting of the envelope with consequent disaster, as soon as a sufficient pressure is attained. With large dirigible balloons, especially those built on sectional plans, incomplete inflation of the gas-containing units is preferred to the use of open necks, since the latter permit a gradual but no less free mingling of the gas with the external air. A danger to be guarded against in the design of open-neck balloons is that of placing the car so close to the opening as to expose the passengers to the risk of complete or partial asphyxiation from prolonged escape of gas.

Internal Balloons, filled with air kept at a constant pressure by some sort of continuously-acting

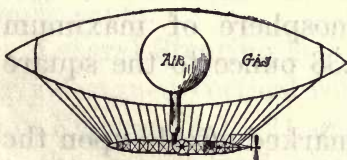

FIGURE 13.—Internal Balloon, used to keep envelope of dirigible taut without filling it so full of gas that some must escape in case of expansion. With this construction, expansion of the gas simply compresses the air bag, which is kept tightly inflated by the blower in the car.

blower device, have been very successfully used in many modern dirigibles, notable among them being that with which Santos Dumont won the Deutsch prize in 1901 (see Page 82), to keep the external envelop tight without the

use of the open-neck scheme and in spite of insufficient inflation. With this construction expansion of the gas simply compresses the internal balloon

and expels a portion of the air from it, but without altering the pressure that it is sought to maintain throughout the entire envelope. A diagram of a dirigible built on this design is given in Figure 13, in which the main gas bag encloses the internal balloon, with the blower in the car below.

Moisture condensed upon the surface or absorbed by the material of a balloon envelope has a marked effect in causing it to descend—partly because the quantity of water thus condensed is by no means slight, and partly because it only requires a very slight addition of weight to occasion a considerable descent. A film of water only $\frac{1}{200}$ inch thick over the entire envelope surface of one of the great Zeppelin dirigibles, for example, adds over half a ton to the weight. As for the effect of moisture actually absorbed, one manufacturing concern, which produces a particularly excellent balloon fabric weighing 9.5 ounces to the square yard, guarantees that the increase in weight from exposure to an atmosphere of maximum humidity will not exceed .38 ounce to the square yard.

Temperature also has marked effects upon the sustentation capacity of balloons, a very small increase in temperature being sufficient to enhance the lift very materially, while, conversely, cooling of the gas shrinks it enough to make it lose much of its ascensional force. In the use of balloons it often has been noticed that drift into the shadow of a dark cloud will cause a descent perhaps of

hundreds of feet, with a corresponding rise upon coming into the bright sun again.

STEERING

Steering a dirigible is easily effected by the manipulation of rudders, provided the speed of the craft through the air is sufficient to set up reactions of sufficient magnitude from the air flow. For slow-moving airships larger rudders are required than suffice for fast-moving craft. Reference to Figures 17, 18, 21 and 22 will afford a clear idea of the rudder schemes employed in modern dirigibles. In addition to the pivoted and movable rudders *a* and *b* in these illustrations, stationary fins *c* also are much used, to help keep an airship to its course, and to reduce spinning when it is not under way. And in some vessels it has been proposed to effect steering by other than rudder schemes for shifting the whole gas bag around by swinging, skewing, or tilting movements.

Lateral Steering is so readily effected by properly designed vertical rudders, such as are marked *a* in Figures 17, 18, 21, and 22, of sizes proportioned to the speeds and sizes of the craft they are intended to control, that experiment with more complicated schemes seems scarcely worth while. Nevertheless considerable attention has been given to devices for swinging the main propellers side-wise, and even to designs in which small side propellers are provided for pulling the whole vehicle around. Seemingly ill-advised on their face, such

systems of control so far have met with no practical success.

In planning the steering of a dirigible, it is necessary, if non-rigid or semi-rigid construction be employed, to allow for the flexibility of the structure and also to make sure that the steering effect shall not twist the car away from its fastenings to the gas bag.

In steering an ordinary balloon by a drag rope, the rope is simply moved from time to time as its reattachment revolves the balloon. By this scheme it is possible to produce only a slight angular deviation from a straight drifting course.

Vertical Steering, by means of horizontal fins or rudders, as shown at *b* and *c* in Figures 17, 18, and 21, is used in some dirigibles with considerable success as means of changing height without recourse to the discharge of gas or ballast. Used for this purpose the effectiveness of fins and rudders is dependent upon the rate of longitudinal progress maintained through the air, as they obviously can be of no effect when the balloon is at rest or merely drifting. Two chief systems of height control on this principle are in use. In one the horizontal surfaces are inclined up or down as direct steering means, while in the other the whole airship is tilted longitudinally by shifting of weight or gas, in which condition fixed fins serve to produce the required change in level under the influence of longitudinal propulsion.

It is said that one of the Zeppelin airships, during the week of March 7, 1909, ascended to

an altitude of 5,643 feet, and descended again "entirely with the use of the elevators", and without discharge of ballast. The secrecy maintained by those concerned in the Zeppelin trials has prevented any definite confirmation of this statement, which if correct is of considerable importance in its bearings upon practical maneuvering and conservation of gas supply.

BALLOON HOUSING

The problem of properly housing large balloons when they are not in use, so as to protect them from wind and weather, is a very serious one. Because of its great bulk any balloon, no matter how stoutly constructed, is essentially fragile when fastened to the ground and exposed to the buffeting even of moderate gales. In the air, of course, the only effect of wind is to cause a drift relative to the earth's surface but not to the surrounding atmosphere. On the ground, however, restrained from drifting by rope or other attachments, the effect of even a light wind is to press the gas bag over and pound it upon the ground. These considerations render imperative the provision of proper housing of some sort. And, such housings being necessarily very large and substantial, and preferably inexpensive enough to permit of extensive placing, it is clear that the question of their design is one to tax the best of architectural abilities and structural methods.

Sheds for housing balloons and aeroplanes—the "*hangars*" of the French aeronauts and avi-

ators, who bid fair to fix this term upon the English language—have been designed in a great variety of forms. The construction of the best of these will be easiest appreciated by reference to Figures 14, 15, and 16, of which Figure 14 shows one building for the dirigible “Russie”, while Figures 16 and 17 show the Clement-Bayard portable balloon house with which the French army is experimenting.

Landing Pits have been proposed as substitutes for balloon sheds, over which they possess the advantages of lower cost and readier improvisation. In a characteristic balloon pit the essential feature is the simple excavation in the earth, large enough to shelter wholly or partly the air craft it is designed to protect. The scheme has been tried, and possesses many features of merit, of covering shallow excavations with low sheds, thus in a measure combining the virtues of both constructions.

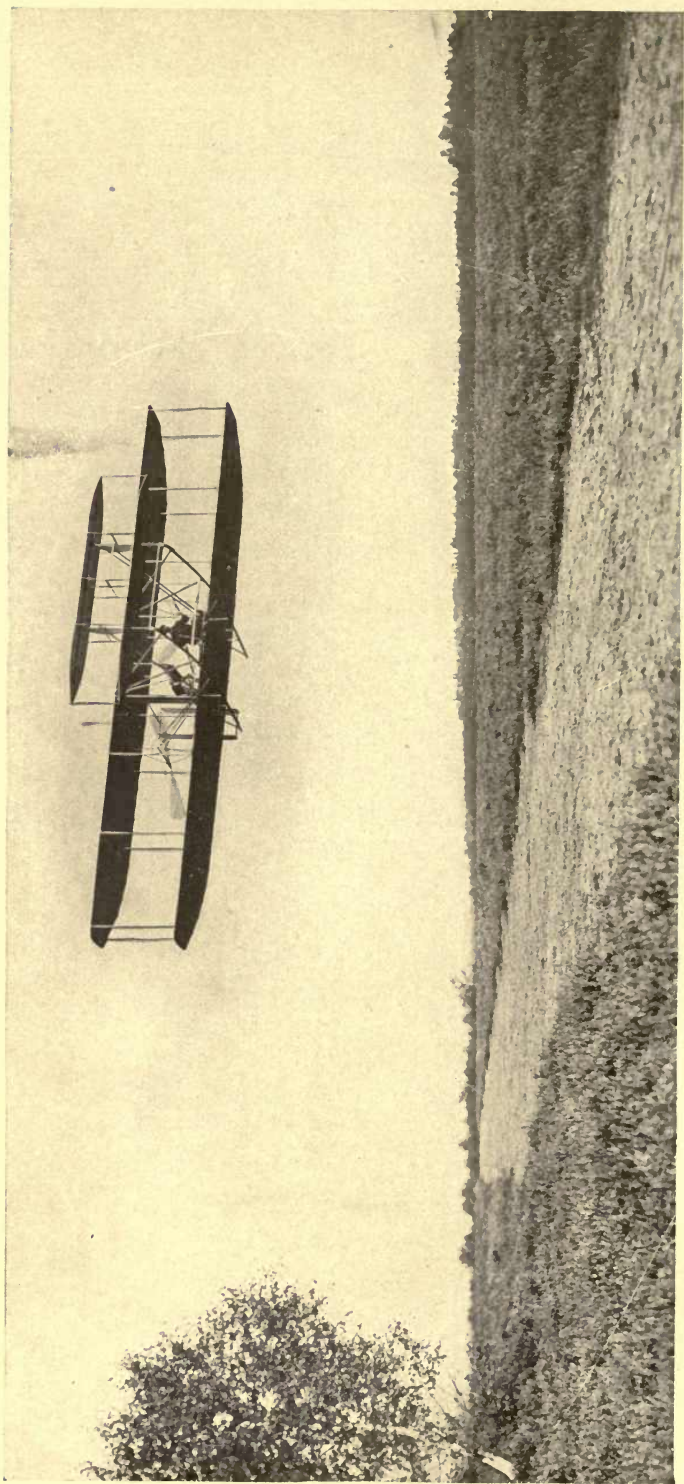

FIGURE 23.—Count de Lambert Piloting Wright Biplane in France. This photograph, which is one of the finest ever secured of an aeroplane in flight, beautifully suggests the useful and enjoyable cross-country flight that is likely to become commonplace in the very near future. It is particularly to be borne in mind, in studying this picture, that there are thousands upon thousands of miles of level surface in almost every inhabited section of the world, over which similarly close-to-the-ground flight is destined to become perfectly practical. As for the question of safety, it is to be understood that with properly-designed machines there is—because of the absence of jolting and vibration—positively less likelihood of breakage affecting the controlling devices or the general structure than there is of a similar mishap to the steering gear of an automobile. Engine failure is, of course, more difficult to guard against, and therefore more or less to be anticipated until further improvements are made. Its occurrence, however, involves nothing more serious than an enforced landing, the machine gliding lightly to the ground under as perfect control as when driven by its motor. Restarting can be accomplished without special appliances by all but the Wright machines. The Wright machines require a simple starting mechanism that can be cheaply duplicated and generally provided, and which has the merit that the machine gets into the air with a shorter run than is required by others.

CHAPTER THREE

HEAVIER-THAN-AIR MACHINES

The idea of machines, heavier than air, which should nevertheless sustain themselves in the air by the operation of suitable mechanism, is an obvious deduction from the observation of the birds and of flying animals and insects, all of which, quite without exception, are vastly heavier than the tenuous medium that so securely supports them. As a consequence, the earliest conceptions of heavier-than-air flying machines long antedate the discovery of the balloon, even the various myths and apocryphal accounts of flying men, which have come down from ancient times, being invariably founded upon one or another of the obvious modifications of the mechanical-bird idea.

In later times, and as science and invention have progressed, attempts innumerable have been made to construct successful machines, but with results so uniformly discouraging that the very term "flying machine" had become a synonym for all that was wild and erratic in inventors' brains and mechanical perversity. However, complete failures though all the ideas of the early air navigators proved when put to the test, in the revealing light of more recent successes it begins to appear that past failures were due less to insuperable

obstacles than to incomplete knowledge—to a failure to understand the essential importance of a very few but most fundamental principles.

The result is that now, as knowledge is accumulated and tested and tabulated in every-increasing increments, and as the great principles are commencing to be wrung from the mazes of indifference and skepticism and ignorance that had so long concealed them, the aerial vehicle is surely and inevitably issuing from the mists of doubt into the realms of the practical.

Of the many varieties of heavier-than-air machines that have been constructed or conceived, nearly all fall into one or another of three basic classifications—ornithopters, helicopters, and aeroplanes.

ORNITHOPTERS

The term ornithopter embraces, as its name implies, any type of flying machine modeled upon the flapping or vibrating action of bird and insect wings. Evidently, the ornithopter being suggested by all common types of birds, it almost certainly preceded all other conceptions in mankind's wonderful and ages-long development of the art of flying.

HISTORY

Possibly the earliest plausible suggestion in recorded history of a machine really capable of flying is the Aulus Gellius reference to the flying dove of Archytas, of which it is gravely asserted

“It was built along the model of a dove or pigeon formed in wood, and so contrived as by a certain mechanical art and power to fly; so nicely was it balanced by weights and put in motion by hidden and enclosed air.” From this most authorities conclude that Archytas’ machine was a more or less successful ornithopter model, but to the writer it seems that there is just a suggestion, in the “balanced by weights and put in motion by hidden and enclosed air”, that the ingenious Archytas might conceivably have demonstrated no more than the flotation of some sort of oddly-shaped and altogether premature toy balloon—surely enough, at this, for a man to achieve so long in advance of his time.

Even antedating the now unappraisable story of Archytas is the seemingly utter myth of Daedalus and Icarus, who, Grecian mythology maintains, undertook to fly over the five hundred odd miles of the Mediterranean that separate Crete from Sicily. If the “wax”-attached wings were made at all and were made to flap, here undoubtedly was the original ornithopter, but all of the probabilities of the exploit are rather discounted by the mythical form of the story and by the further fact that it required a matter of several thousand years of progress to enable Bleriot and Latham to reënact the respective roles over a much shorter distance.

Coming down to modern times and passing by without consideration various unauthenticated or less successful ornithopters, with accounts of

which mechanical history commencing with the middle ages is not infrequently embellished,* possibly the first ornithopter really to produce measurable sustentation was that of Degen, who

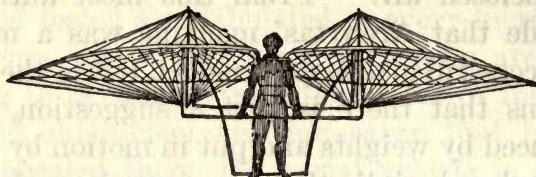

FIGURE 24.—Degen's Orthogonal Flier.

in 1809 rose to a height of 54 feet by violently flapping the deeply-concave wings illustrated in Figure 24, which totaled 116 square feet in area and were covered with taffeta bands arranged to afford a valvular action similar to that of the feathers of the bird's wing. Most accounts of the

* Among the more interesting of these accounts are those concerning the construction proposed by *Leonardo da Vinci*, the sound reasoning of *Borelli*, the mishap that befel the tight-rope dancer *Allard*, the seemingly interesting but now lost mechanism of *Besnier*, the unfortunate descent of the *Marquis de Bacqueville* into the washerwoman's barge in the Seine, the failure of the *Abbé Desforges*, the flying chariot of *Blanchard* the balloonist, the feathering wings of *Bourcart*, the figure-eight action of *Dandrieux*' machine, the *Gibson* feathering wings, the early explosion engine and the magnified stag beetle of *Quartermain*, the *Cayley* umbrella machine, the parachute-and-wing combination in which *Letur* met his death, the similar device of *De Groof* that also proved fatal to its inventor, the proposed *Meerwein* apparatus, the *Bréant* artificial bat, the first attempt of *Le Bris*, the very wild *Gerard* project, the unsuccessful *Artingstall* model, the multi-wing craft of *Struvé* and *Teleschiff*, the *Palmer* wing action, the *Kaufmann* ornithopter propulsion, the *Jay* model, the fairly successful steam toy of the Leipsic optician, the *Prigent* dragon fly, the important *Jobert* and *Penaud* introduction of rubber-band propulsion with the result of producing successful models, the subsequent improvements in flying models by *Pichancourt*, the *De Louvrie* fiasco, the *Quinby*, *Lamboley*, *Murrell*, *Keith*, *Green*, *Baldwin* and *Wheeler* patents, the *Sutton*, *Pettigrew*, and *Marey* observations, the *Frost* steam bird, the 45-foot *Moore* bat, the original beating-wing machine of *Ader*, and the *Napier*, *Smyth*, *Alexander*, *De Labouret*, *Tatin*, *Richet*, *Chanute*, and other calculations, all of which are interestingly treated, at the cost of much research and labor, in *Chanute's* book, "*Progress in Flying Machines*," published in 1891-1894.

Degen apparatus omit to state that it lifted only 70 of the 160 pounds of operator and machine, the other 90 pounds being balanced by a small balloon or a counterweight attached to a rope passing over a pulley. Therefore, considerable though Degen's success really was, it actually indicated man's inability rather than any ability to fly by his own muscular efforts applied to an orthogonal mechanism.

Among those that came after the Degen machine, one of the most interesting was the exceptionally ingenious Trouvé model, illustrated and

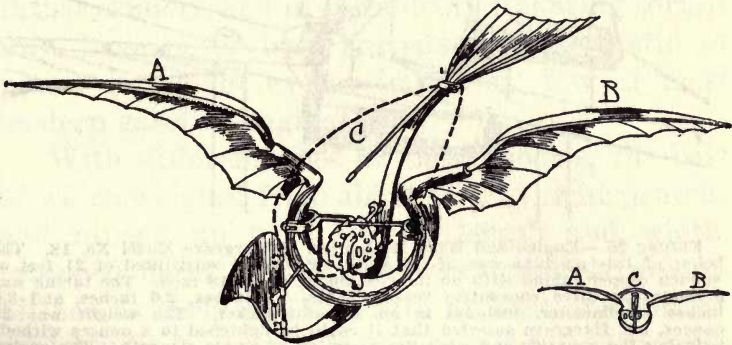

FIGURE 25.—Trouvé's Flapping Flier. In this machine the two wings, A and B, are connected together by a flattened tube, the "Bourdon" tube of steam gages, etc., the particular property of which is its tendency to straighten out when subjected to the influence of an internal pressure. In this model pressure is intermittently supplied by the successive explosion of cartridges in the revolver barrel—shown in the U of the tube—which communicates with the interior. In this way a series of vigorous flaps can be obtained, with flight for as much as 240 feet.

described in Figure 25. Not the least curious feature of this model was the method of starting it by the use of two strings, successively cut by a candle and a blowpipe flame.*

* Described in Chanute's "*Progress in Flying Machines.*"

A most ingenious, persistent, unselfish, and well-equipped investigator of flying-machine problems is Laurence Hargrave, of Sidney, Australia, who is known the world over as the inventor of the box kite (see Figure 34).

In the course of his experiments with ornithopter constructions—in which flapping wings were

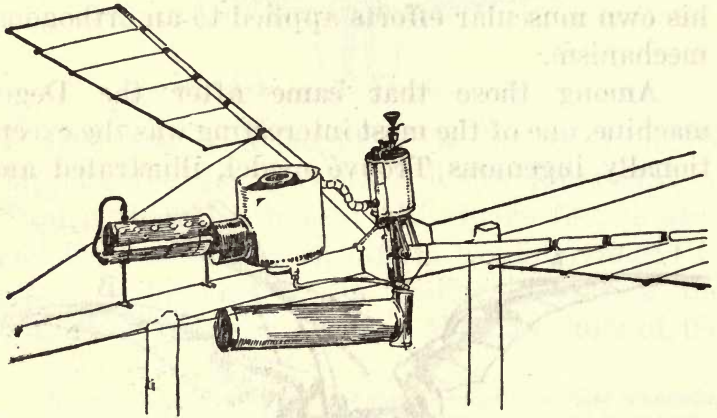

FIGURE 26.—Engine and Wing Mechanism of Hargrave Model No. 18. The boiler of this machine was of the water-tube type, constituted of 21 feet of $\frac{1}{4}$ -inch copper tubing with an internal diameter of .18 inch. The tubing was arranged in three concentric vertical coils, 1.6 inches, 2.6 inches, and 3.6 inches in diameter, inclosed in an asbestos jacket. The weight was 37 ounces, but Hargrave asserted that it could be lightened to 8 ounces without reducing the capacity and with the retention of ample strength. The engine was single-cylinder, double-acting, of 2 inches bore and 2.52 inches stroke, and with piston valves .3 inch in diameter. The wings were flapped directly, with no conversion of the reciprocating into rotary motion, and the highest speed attained was 342 strokes a minute. The total weight of engine, boiler, and 21 ounces of water and alcohol, enough to feed the boiler and burner for four minutes, was 7 pounds. The indicated horsepower was .653, with a capacity for evaporating 14.7 cub'c inches of water, with 4.13 cubic inches of alcohol, in thirty seconds. This figures 8.71 pounds to the horsepower for the power plant with tanks empty, or 5.93 pounds to the horsepower were the expected lightening of the boiler realized. The wings were 36 inches long, with the outer 22 inches covered with paper, 4 inches wide at the inner ends and 9 inches wide at the tips—a total of 286 square inches for the two wings. Thrusts of as high as one pound were obtained and machines of similar type flew distances of several hundred feet. The flapping wings were used for propulsion alone, sustentation being had from the large aeroplane surface to the rear.

invariably employed for propulsion, not sustentation—Hargrave built eighteen different machines,

commencing 1883 and culminating in 1893, with the machine illustrated and described in Figure 26. Of the eighteen machines, which were built on similar lines but variously propelled by clockwork, rubber bands in torsion and tension, compressed air, and steam, several were built with single and double and traction and thrust screw propellers, that the action and efficiencies of these might be compared with one another and with the wings.

A remarkable feature of many of the Hargrave models is the wonderful lightness of the small power plants, which while built inexpensively, rather crudely, and in a decidedly tinkering sort of way, have never been surpassed in the ratio of power to weight except in a very few of most modern gasoline engines.

With different ones of these models, the best of which weighed from about four to eight pounds, and ranged up to 6 feet in length and width, recorded flight of 343 feet was definitely accomplished as early as 1891, with at least one similar model built to carry within its weight limit enough fuel to fly for a mile. The maximum speeds attained were about 17 miles an hour.

After 1893, when his box or "cellular" kite was developed, Hargrave turned his attention to the development of this type of sustaining surface, which has come to be regarded as the direct prototype of at least one most successful modern biplane—the Voisin.

TWO CHIEF CLASSES

The work of Hargrave particularly emphasizes the fact that the ornithopter principle is capable of application to either of two wholly different classes of machines—those sustained in the air solely by the movement of the wings, and others, usually aeroplanes, in which the flapping is used simply for propulsion. For further consideration of ornithopter propulsion see Page 25.

RECENT ORNITHOPTERS

At the time this is written the only known successful machiness of the ornithopter type are the very small models of Jobert, Penaud, Pichancourt, Trouvé, and Hargrave—the latter being really aeroplanes with ornithopter propulsion. Furthermore, no materially greater success seems at all probable, for the reasons explained on Page 25—reasons that are further upheld by the invariable failure and unmechanical construction of every ornithopter of man-carrying size that has so far appeared. A characteristic example is the machine illustrated in Figure 27, in which are wing structures and actuating elements are nowhere near strong enough to withstand the rate of flapping necessary to effect sustentation. Another example was the Farcot machine, exhibited in Paris in October, 1909.

ANALOGIES IN NATURE

That the flapping-wing machine has not met with the success of its animal prototypes is beyond any question due to the invariable superiority of

rotating over reciprocating mechanisms in all mechanical structures man has the means and the knowledge to devise, and in which the one most conspicuous feature is the frequent use of the wheel and its various equivalents, which are unknown in nature apparently not because they are not superior but because they are not available. This view, which is somewhat amplified on Page 26, gives ground for the belief that as man does learn to fly he will do so more efficiently though not necessarily as safely as the birds, just as his water craft excel the inhabitants of the deep and his land vehicles the creatures of the land in speed, sustained travel, and loads carried.

HELICOPTERS

Though in almost the same status as the ornithopter, in so far as any measurable success that has been achieved is concerned, engineers are nevertheless inclined to regard with some measure of respect the helicopter principle, which in many essentials appears to be quite sound engineering, and which is vigorously defended by men like Edison, Berliner, Cornu, Breguet, and others. Even the assertion that, no matter what success may be attained with the helicopter, it must always prove unsafe upon failure of the power, is met by plausible and well-backed reasoning to the effect that the propeller areas can be sufficient to prevent abrupt descent, causing the machine simply to act as a parachute in case the power

fails. As for an analogy in nature, it is a fact that the delicately-twisted wing of the ash seed by causing fairly rapid revolution definitely retards the fall. The forms of maple and sycamore seeds, too, produce a similar effect, though these are less screw-propeller-like. In the matter of sustentation, while it is true that nature finds the helicopter principle unavailable, it is a fact that in the cases of humming birds and many insects there is to be found the closest imaginable approximation to this principle, in the use of flat blade-like wings that buzz to and fro with rapidly reversing angles of incidence through arcs as great as 250° .

It has been frequently sought to combine the helicopter principle with that of the aeroplane, as in balanced balloons in which it is sought to cause the vessel to ascend or descend by revolving a propeller in a horizontal plane. A recent combination of a helicopter with an aeroplane is shown in Figure 33.

HISTORY

Leonardo da Vinci, the wonderful Italian genius of the middle ages, who looms so large in so many fields of endeavor, did not overlook the possibilities of the helicopter as a means to man flight, for in one of his note books there is a sketch of a proposed lifting propeller 96 feet in diameter, to be built of iron and bamboo framing, covered with starched linen. The idea was evidently dropped because of the power required, but it is recorded that light paper propellers were experi-

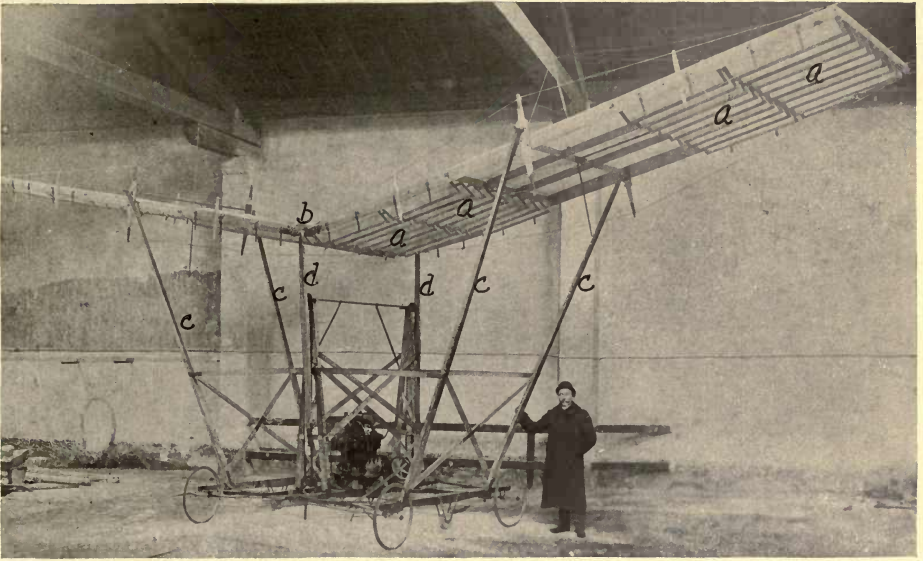

FIGURE 27.—Collomb Ornithopter. This machine is of the direct, orthogonal flapping-wing type, provided with valvular flaps at *a a a a*. The two wings, which pivot at the upper extremities of the links *c c c c*, are reciprocated by the vertical reciprocation of the arms *d d*.

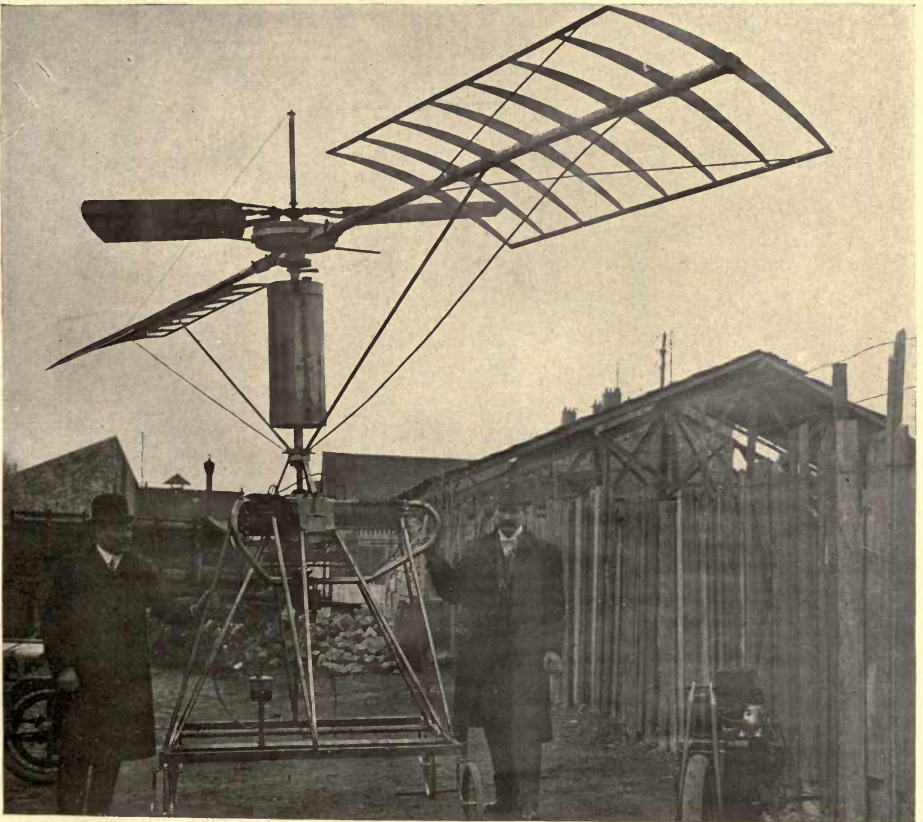

FIGURE 31.—Bertin Helicopter.

mented with and made to ascend for very brief periods.

In 1784, only a year after the Montgolfiers' first balloon ascension, Launoy and Bienvenu jointly exhibited before the French Academy of Sciences the little helicopter pictured in Figure 28. This toy, which can be easily made from a couple of corks, a few feathers, a piece of thread, and a splint of bamboo, is an excellent flier, continuing to ascend until the thread is completely unwound.

Of the totally unsuccessful or merely projected helicopters there has been a great number, few of which merit description except in a work devoted to the historical rather than to the practical in aeronautics.

The next advance in helicopters after the

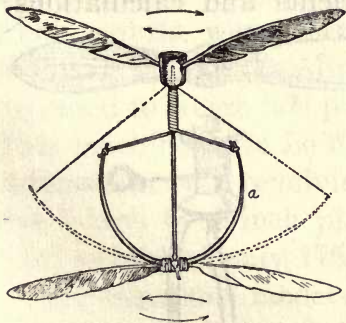

FIGURE 28.—Toy Helicopter. The four propeller blades are suitably placed feathers and the power is derived from the bamboo splint *a*, which in straightening out as suggested by the dotted lines revolves the vertical shaft.

Launoy and Bienvenu invention was made by W. H. Phillips, who in 1842 made a 2-pound helicopter, driven by a reaction turbine similar to the first engine, attributed to Hero, of Alexandria. This model is stated to have flown across two large fields, but was badly broken in landing.

In 1870 Penaud devised a toy helicopter, driven by a rubber band and exactly similar to that shown in Figure 29, except that in place of the large surfaces to keep the whole apparatus from turning

a duplicate screw was provided at the bottom, as in Figure 28. Flights of nearly half a minute were obtained—much longer than had been previously obtained with lifting screws.

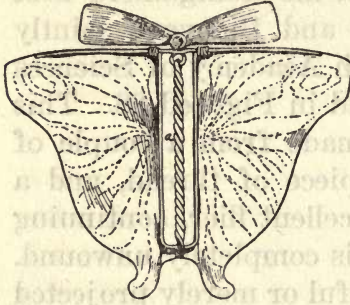

FIGURE 29.—Toy Helicopter. By turning the propeller until the rubber band *a* is tightly twisted, energy enough is stored for a short flight, the large wings resisting the tendency of the whole device to revolve oppositely to the propeller.

The helicopter shown in Figure 29 was invented by Dandrieux, and has been extensively manufactured in France and Japan as a toy.

Another common toy, said to have developed from the Penaud helicopter, is that shown in Figure 30. Wenham made exhaustive measurements and calculations with these toys, and estimated that the best of them will lift 33 pounds per horsepower—well within the capacity of many modern engines, even of large size.



Subsequent to this Edison, Renard, and Maxim conducted exhaustive tests of propeller thrusts, for lift-

FIGURE 30.—Toy Helicopter. By rapidly pulling the string the propeller is revolved at such speed as to cause it to rise off the spool and ascend a considerable distance in the air.

ing as well as for propulsion, but their work proved only of scientific, rather than of practical value.

Also, the findings of these early investigators have for the most part been kept secret, leaving the subject still much in need of investigation and elucidation.

RECENT EXPERIMENTS

Emil Berliner, the famous telephone inventor, has given considerable attention to the development of the helicopter principle, and according to recent accounts had tested in Washington, D. C., a machine expected to weigh, with operator, only a little over 300 pounds. This machine was provided with a 36-horsepower revolving-cylinder Adams-Farwell motor, weighing 100 pounds and running normally at 1400 revolutions a minute, but geared to drive the 17-foot propeller at 150 revolutions a minute. At this speed a lift of 360 pounds was calculated, but it is not known what results were secured in the actual tests. Berliner is now building a twin-screw machine, expected to weigh 500 pounds and lift 720 pounds. This machine is to be driven by a 55-horsepower Adams-Farwell revolving-cylinder engine, with five 5-inch by 5-inch plain steel cylinders, and a total weight of only 175 pounds.

An ingenious modern helicopter, seemingly of fairly sound design but not proved successful is that illustrated in Figure 31.

Another interesting new helicopter is that of Cornu, which is illustrated in Figure 32. In tests this has proved to lift, but has never been permitted to rise more than 15 inches from the ground, for fear of accident.

On July 22, 1908, the Breguet helicopter-aeroplane is said to have flown 64 feet at a maximum height of 15 feet.

LATERAL PROGRESSION

After the problem of efficient, reliable, and safe sustentation with the helicopter is solved, there will still remain the problem of securing controlled lateral and angular movement. Probably the commonest as well as the most promising proposal contemplates a tilting of the screw, or of the machine—which amounts to the same thing—so that there will be a combined lateral and vertical thrust. In actual tests of the Beliner helicopter, it is said to have been established that with the plane of rotation inclined 15° the loss in lift was less than 3%, while the horizontal element of the thrust was 25% of the lift.

Another common plan for lateral propulsion consists in the use of supplementary propellers on a horizontal axis, in addition to the lifting screw on a vertical axis. Such a combination appears in the machine illustrated in Figure 33.

The Cornu machine, shown in Figure 32, is intended to be steered by rudders.

It is a point in favor of the helicopter that the sustaining effect of a propeller is materially greater when it is given movement parallel to its plane of rotation than it is when tested without change of location. This effect appears to be due to the advantage of working against new air in preference to that already set in movement.

ANALOGY WITH AEROPLANE

It is not to be forgotten, in any consideration of the practicability or the prospects of the helicopter, that its propeller-blade surfaces are essentially aeroplanes caused to travel in circular paths. This would seem to bring their action within the domain of practically the identical laws that apply to the aeroplane, and might be taken to offer similar promise of future success, once the peculiarities of the particular application are properly worked out.

AEROPLANES

This subject is too important to treat exhaustively here, for which reason Chapters 4 and 13 have been entirely given over to descriptions, and to consideration of the technical details involved in the construction of successful modern aeroplanes, leaving it necessary here only to outline the more important historical facts that relate to the aeroplane.

Just as the ornithopter developed from observation of the more difficult flight of common flapping wing creatures, so the aeroplane has developed from observation of the magnificent effortless flight of the less-common soaring birds.

There is no possible doubt but what the aeroplane is the first successful, and very probably destined to continue the most successful, type of flying machine. Almost everything is in its favor. In its best forms, for example, its inherent stability as a glider may constitute an almost perfect

safeguard against the possibility of accident due to motor failure. Moreover, the aeroplane certainly will prove far cheaper to build and to operate than any conceivable type of ornithopter, and probably cheaper than any helicopter that will begin to afford equivalent speeds, lifts, or efficiencies.

AEROPLANE HISTORY

The history of the aeroplane involves the development of three more or less separate conceptions—the first, the use of gliding surfaces as means of riding down a slant of air from a greater height to a lower; the second, the application of power-operated propelling elements for continuing on a horizontal course or progressing on an upward slant; and the third, the idea of indefinite soaring without power by the utilization of obscure and little understood, but very evident principles, that are clearly demonstrated to exist in the flight of soaring birds—a mode of flight concerning which there has been much speculation and controversy, and the performance of which is variously attributed to the phenomenon of rising currents in the atmosphere, to the presence of constantly varying factors in the horizontal movement of winds, and to the operation of laws not yet generally formulated or recognized. Probably the real explanation lies in some measure of sound reasoning that is to be found in both the first and the third of these explanations.

Just as the ornithopter is a logical-enough outgrowth from observations of the flapping flight of

birds, so the aeroplane is an inevitable deduction from the flight of soaring birds. And so absolute has been the ignorance and misunderstanding of the phenomena of soaring flight that even today the most successful aeroplanes are in many instances radically incorrect surfaces made to fly not so much by sound design and engineering refinement as by being inefficiently dragged through the air by sheer force of the excessive power that has become available in modern light-weight engines.

Of the many investigators of aeroplane problems, it is a safe assertion that the most important, original, and successful work that has been done is fairly to be ascribed to a comparatively small number of men—preëminent among whom are Ader, Bleriot, Chanute, Langley, the Lilienthals, Montgomery, Penaud, Pilcher, Santos-Dumont, Wenham, the Wrights, and the Voisins. While this list may not at all fit the selections or opinions of other compilers it at least represents a serious and unbiased effort justly to appraise the comparative value of the many different contributions to aeronautical progress, and certainly it must be admitted that the men it includes are in any case possessed of a forever unassailable rank in this field of engineering. As for the many important omissions, these are in no sense intended to disparage the earnest and valuable researches of a considerable number of able and disinterested students, who in more than one instance have freely given years of their lives and large sums of money to the always thankless task of contributing to the

progress of the race in advance of commercial demand and in the face of popular skepticism. But, in the case of each of these omissions, it is the writer's belief that no fair and unprejudiced analysis can fail to discover either such lack of originality or of success as must properly reduce to a secondary status the particular experiments affected.

CLEMENT ADER

In 1872 this inventor, well known as one of the European pioneers in the development of the telephone, constructed a 53-pound ornithopter apparatus in the form of a bird of a 26-foot wing spread, intended to be flown by the strength of the operator's muscles. Failure naturally resulting, the project was dropped and it was not until 1891 that Ader began his aeroplane experiments with the construction of a bat-like machine, 54 feet across, weighing 1100 pounds, and drawn through the air by two four-bladed tractor screws, driven by a twenty or thirty horsepower steam power plant. Fully \$120,000 was expended in the experiments, and the result was the first flight of a man-carrying power-propelled aeroplane, for a distance of only 164 feet, on October 9, 1890. Subsequently, on October 14, 1897, at Satory, France, a semicircular flight of nearly 1000 feet was accomplished with a machine started by a run along the ground on wheels. In both of these trials the machines were wrecked because of deficient equilibrium.

LOUIS BLERIOT

One of the earliest among the successful aeroplane builders of the world is Louis Bleriot, who has long been noted as one of the foremost automobile-lamp manufacturers in Europe, and whose experiments commenced like those of so many others with a flapping-wing machine, built in 1901. Following the failure of this, nothing more was done until during 1905, when some interesting experiments were made with a towed biplane glider—Bleriot II—mounted on hydroplanes. The Bleriot III was a double biplane of box kite form, but with semicircular instead of vertical ends. It was provided with a motor but no success resulted from attempts to make it rise from the Seine, on the surface of which it was floated like its predecessor. Bleriot IV was Bleriot III modified by removal of the semicircular ends from the front cell, but not until experiments on land were substituted for those over water and a double monoplane for the biplane was the first real flight accomplished—in July, 1907. After this the monoplane principle was rapidly developed, with numerous successes in 1908 and more in 1909, culminating in the wonderful cross-country flights in the spring and summer of the latter year, and, finally, in the memorable crossing of the English Channel in one of the smallest, speediest, lowest-powered, and cheapest aeroplanes yet built.

OCTAVE CHANUTE

Commencing in 1896 with experiments with a Lilienthal glider, this well-known engineer, noted as a bridge and railway builder, progressed to the development of machines of his own design, devised to eliminate the dangers and improve upon the results encountered in the use of the Lilienthal apparatus. The trials made at Dune Park, Indiana, by Chanute and his assistants, A. M. Herring and William Avery, quickly led to the use of multi-surface machines, of as many as four or five superimposed decks. With these—particularly with the biplane (see Figure 237) that the Wrights subsequently developed, with Chanute's constant assistance and advice and frequent presence from the very first experiments until flying was actually accomplished, and with a similar triplane—over 2000 glides, of a maximum length of 360 feet, were safely accomplished. A feature of the final Chanute machines was the use of a modified form of swinging wing tip, patented by Chanute in the form illustrated in Figure 261.

SAMUEL PIERPONT LANGLEY

One of the most painstaking, well-equipped, and successful students of aerodynamic problems was Professor Langley, of the Smithsonian Institution, who, after much preliminary investigation of the action of supporting surfaces constructed a number of double-monoplane models, of the type illustrated in Figure 70, which repeatedly flew for distances

of half a mile and more over the Potomac River. The first of these flights was on May 6, 1896, and is described in *Nature*—issue of May 28, 1896—by Alexander Graham Bell, who witnessed it. After exhaustive and uniformly successful experiments with models, an appropriation of \$50,000 from the United States War Department was expended in the construction of a similar machine of man-carrying size, weighing 830 pounds and propelled by a 52-horsepower gasoline engine. This machine was twice tried, on October 7 and December 8, 1903, but both times was plunged in the Potomac by defects in the launching apparatus. It is a general belief that in calm weather this machine is capable of fairly stable flight, but no tests have been made of it since the inconclusive trials referred to.

OTTO AND GUSTAV LILIENTHAL

Probably no other worker in the history of aeronautical science is entitled to a higher place than Otto Lilienthal, whose early and thorough investigation of the subject, in association with his brother Gustav, have formed the groundwork for a large proportion of subsequent successful experiments, and whose martyrdom to the advancement of flight is a loss that never can be estimated. Lilienthal's investigations, which commenced in 1871 and progressed to actual gliding experiments in 1891, were of a thoroughness that few have exceeded, many of his conclusions being still regarded as part of the gospel of most students. All told he performed over 2000 glides, of a maximum length

of 1000 feet and at a maximum speed of twenty-two miles an hour. Though originally a firm believer in the monoplane (see Figures 230, 231, and 263), and in the ultimate attainment of soaring flight, in 1896 he built a $2\frac{1}{2}$ -horsepower motor, weighing 88 pounds, and it was in testing the biplane sketched in Figure 232, to which he proposed the application of flapping propulsion by the use of his motor, that he met his death by a fall from a height of 50 feet, on August 10, 1896.

JOHN J. MONTGOMERY

The history of engineering abounds in examples of the struggling inventor who, having realized the labor of his brain in the form of a concrete mechanism of more or less incalculable value, is thereafter accorded neither deserved recognition nor any adequate share in the material returns from his work, which is commonly seized and exploited by more assertive egotisms and sturdier greeds.*

On April 29, 1905, in California, there was publicly performed a feat which no competent and unprejudiced person who investigates its details can fail to characterize as the greatest single advance in the history of aerial navigation. For on this day

* It is a fact perhaps worthy of remark that much in the spirit and methods of the times make such a condition perfectly to be expected. A large proportion of the lay press and the general public, the one catering to and deriving its support from the other, possess neither the deliberate outlook nor the special knowledge necessary to just appreciation and appraisals of technical merits and values, while the average institutions of higher learning, from which the inculcation of better-balanced opinions might be reasonably expected, are too commonly devoted to following instead of leading scientific progress, and to occupying the developing mind with mnemonic feats of remembering solved problems instead of with the exercise of reasoning out unsolved ones.

there ascended from the college grounds at Santa Clara, in the presence of thousands of spectators, an ordinary heated air balloon—to which was attached, not a parachute, but a 45-pound glider designed by Professor Montgomery and mounted by an intrepid parachute jumper, Daniel Maloney (see Figures 225, 226, 227, and 260).

At a height of about 4000 feet the aeroplane was cut loose from the balloon and commenced to glide, under the most absolute control imaginable, to the ground. In the course of the descent the most extraordinary and complex maneuvers were accomplished—spiral and circling turns being executed with an ease and grace almost beyond description, level travel accomplished with the wind and against it, figure-eight evolutions performed without difficulty, and hair-raising dives were terminated by abrupt checking of the movement by changing the angles of the wing surfaces. At times the speed, as estimated by eye witnesses, was over sixty-eight miles an hour, and yet after a flight of approximately eight miles in twenty minutes the machine was brought to rest upon a previously designated spot, three-quarters of a mile from where the balloon had been released, so lightly that the aviator was not even jarred, despite the fact that he was compelled to land on his feet, not on a special alighting gear.

All of the facts of this wonderful flight are well attested. Newspaper men who were present could not find terms extravagant enough adequately to praise what they witnessed. The correspondent of

the *Scientific American*, in the issue of that periodical published on May 20, 1905, declared that "An aeroplane has been constructed that in all circumstances will retain its equilibrium and is subject in its gliding flight to the control and guidance of an operator." Octave Chanute characterized the flight as "the most daring feat ever attempted", and Alexander Graham Bell had no hesitation in asserting that "all subsequent attempts in aviation must begin with the Montgomery machine."*

While it is difficult for a trained engineer, for the first time made acquainted with Montgomery's work, to prevent being overwhelmed by its extent

* It is a fact of quite unescapable significance that recent activity and present successes in aeronautics do date most definitely from the public flights of the Montgomery machine in 1905.

On page 48 of the June issue of *Motor* of that year—in which magazine the writer had been for some time giving space to a column on aeronautics—an account of the Montgomery flights and an illustrated description of the Montgomery machine was published. Prior to this publication, and the accounts in the *Scientific American* already referred to, all attempts at flight, without a solitary exception that is authenticated, had been marked by ever-present uncertainty as to equilibrium, constant hazard to the operator, and frequent accidents—ranging from minor mishaps to fearful fatalities. The longest flights with man-carrying machines that are definitely substantiated before this time were the maximums of 1000 feet by Lilienthal and Ader, the 852 feet by the Wrights in 1903, and the 1377-foot flight by the Wrights in 1904, witnessed by Octave Chanute. All of these ended in damage to the apparatus. Subsequent to publication and circulation of these accounts there promptly followed the experiments with motor-propelled machines by Ferber in France during 1905; the fairly successful glides of Archdeacon, and of Bleriot and the Voisins, over the Seine in June and July, 1905; the remarkable sustained flights of the Wright brothers over Huffman Prairie, Ohio, between September 26 and October 5, 1905, and the flights of Santos-Dumont, at Bagatelle, France, in August and September, 1906.

From the foregoing it seems perfectly fair to state that it was Montgomery's successes that gave definite and recorded beginning to the now fast advancing period of man's mastery over the most elusive medium in which he aspires to travel—mastery absolutely comparable to that of the bird, fruitlessly envied and copied, and copied and envied, by earth-bound man from the fables of antiquity until March and April, 1905.

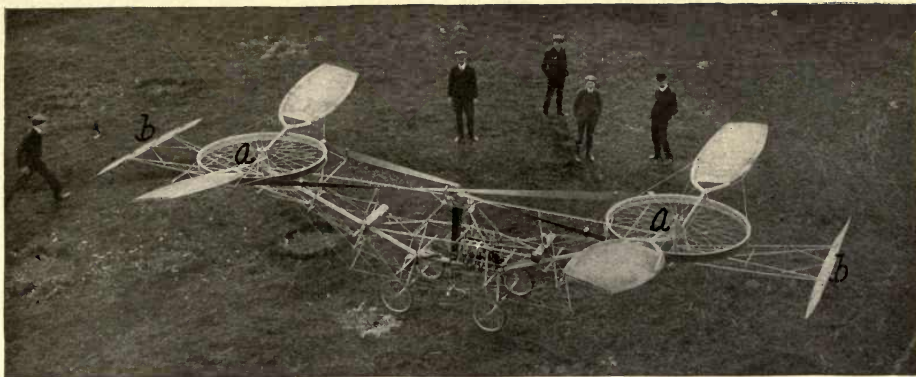

FIGURE 32.—Cornu Helicopter. This curious-appearing contrivance is the creation of a prominent European engineer who has given years of study to this problem. The two lifting propellers at *aa* are mounted on bicycle-like wheels and are belt-driven in opposite directions from a vertical shaft. The flat surfaces *bb* are for lateral control and steering.

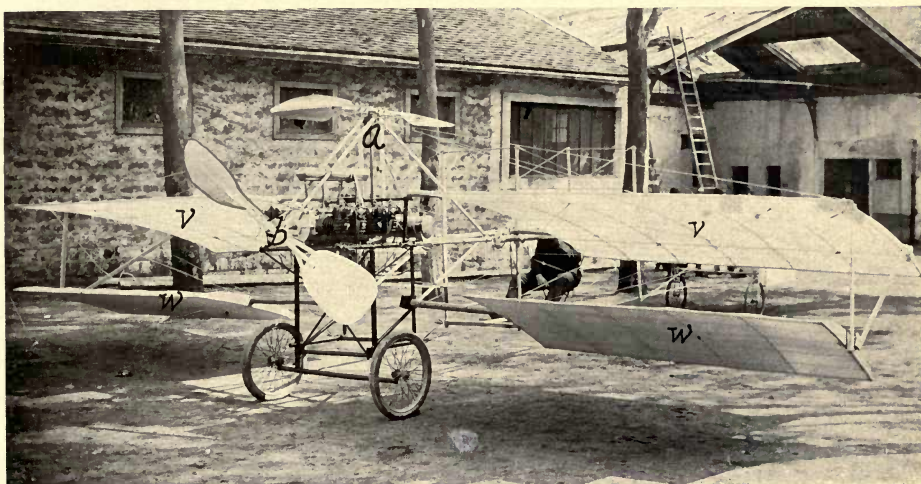

FIGURE 33.—Bertin Helicopter Aeroplane.

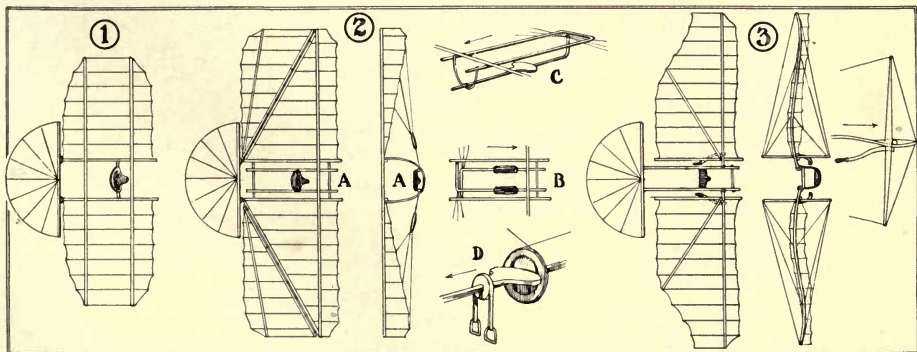

FIGURE 35.—Montgomery Aeroplanes of 1884-5 with Hinged Allerons in Wings. The first aeroplane built by Montgomery was Number 1, above, this being an arbitrary reproduction of a gull's wings, with no control but the vertical movement of the tail. With it one 600-foot glide was accomplished rather precariously, and it was broken in an attempt to repeat the feat. Number 2 had the diagonal hinges shown, by means of which the rear portions of the wings were dissimilarly drawn down by the tilt of the operator's body on the seat, through the various mechanisms shown at *AA*, *C*, *B*, and *D*. Number 3 was a close copy of a turkey buzzard's wings, both in rib curvature and in front sinuosity, and the wings were similarly or dissimilarly rocked by the hand levers shown. These three machines were described in 1895 on pages 248 and 249 of Chanute's "Progress in Flying Machines."

and importance, it is a singular though not inexplicable fact that the general public has in no measurable degree appreciated what he has accomplished. Even eye witnesses of the California flights as a rule seemed to imagine that something akin to a parachute jump was in progress, few realizing that the one great problem of aerial navigation from the beginning had been that of controlled flight and maintained equilibrium, which here, for the first time in history, it was their privilege to witness.*

Of even greater importance than his experimental demonstrations have been Professor Montgomery's profound researches in aerodynamics.† The son of a former assistant attorney-general of the United States, he was graduated in 1879 from St. Ignatius College,‡ in San Francisco, with abundant equipment and opportunities for investigation of his favorite subject, to which he has devoted

* It has been long recognized by all authorities on the subject that the problem of propulsion is a comparatively minor matter, especially now that high-power and light-weight motors have been made widely available by the development of the automobile. Lilienthal, D'Esterno, and Mouillard all have expressed the conviction that indefinite soaring flight is as positively possible as it is certain that birds perform it; Langley wrote his paper on "The Internal Work of the Wind" in an effort to explain this phenomenon; Chanute, in his essay on "Soaring Flight," stoutly contends that we are on the verge of its accomplishment; and Wilbur Wright is authority for the statement that "there is another way of flying which requires no artificial motor" and which "is as well able to support a flying machine as a bird"—while even in the Wright patent specifications there is contemplated flight "either by the application of mechanical power or by the utilization of the force of gravity."

† For details of Montgomery's investigations and conclusions see Chapter 4.

‡ Classmates of Professor Montgomery were James D. Phelan, mayor of San Francisco, 1896-1902, and Rev. R. H. Bell, well known for his researches in wireless telegraphy.

the larger portion of his life. First attracted to aeronautical problems as a boy in 1877, it was not until 1883 that Montgomery built his first machine, a flapping-wing contrivance of such merits that one experiment was enough to convince its designer that success was not to be found in this direction.

From this beginning dated a period of consistent experimenting, which for priority, originality, and quality of its practical results and theoretical conclusions has not been approached by any subsequent investigator. During 1884-85 three gliders * were built, from the first of which a glide of 600 feet † was obtained and the lifting value of curved surfaces (copied from the sea-gull's wings) demonstrated; from the second of which the futility of flat surfaces was proved, but in which diagonally-hinged rear wing portions were used (practically analogous to the Farman device that the Wrights are seeking to enjoin at the present time) ‡; and in the third of which the lateral equilibrium was maintained by pivoted wings. ¶

Besides the flight at Santa Clara, many others were made, some of them presenting most remark-

* These gliders are described in Chanute's "*Progress in Flying Machines.*" See also Figure 35.

† It is to be noted that this glide, which was performed eight or nine years before Lillienthal's experiments, ranks well in distance with them and with the best subsequent glides of Pilcher, Chanute, the Wrights, and others referred to in the tabular history of flights which commences on page 476.

‡ This construction, which is illustrated in Figure 35, is described in Chanute's "*Progress in Flying Machines,*" on page 249.

¶ This arrangement is one that has been used with success in some of the latest Antoinette machines.

able features and one terminating in a fatal accident. The full details of these are deemed of sufficient importance to warrant reproduction in its entirety of an article originally published in *The Aeroplane*, in 1905, and republished in January, 1909, in *Aeronautics*. This article follows without alteration except to correct typography, etc.:

“When I commenced practical demonstration in my work with aeroplanes I had before me three points; First, equilibrium; second, complete control; and third, long continued or soaring flight. In starting I constructed and tested three sets of models, each in advance of the other in regard to the continuance of their soaring powers, but all equally perfect as to equilibrium and control. These models were tested by dropping them from a cable stretched between two mountain tops, with various loads, adjustments and positions. And it made no difference whether the models were dropped upside down or any other conceivable position, they always found their equilibrium immediately and glided safely to earth.

“Then I constructed a large machine patterned after the first model, and with the assistance of three cowboy friends personally made a number of flights in the steep mountains near San Juan (a hundred miles distant). In making these flights I simply took the aeroplane and made a running jump. These tests were discontinued after I put my foot in a squirrel hole in landing and hurt my leg.

“The following year I commenced the work on a larger scale, by engaging aeronauts to ride my aeroplane dropped from balloons. During this work I used five hot-air balloons and one gas balloon, five or six aeroplanes, three riders—Maloney, Wilkie and De-

folco—and had sixteen applicants on my list and had a training station to prepare any when I needed them.

“Exhibitions were given in Santa Cruz, San Jose, Santa Clara, Oakland, and Sacramento. The flights that were made, instead of being haphazard affairs, were in the order of safety and development. In the first flight of an aeronaut the aeroplane was so arranged that the rider had little liberty of action, consequently he could make only a limited flight. In some of the first flights, the aeroplane did little more than settle in the air. But as the rider gained experience in each successive flight I changed the adjustments, giving him more liberty of action, so he could obtain longer flights and more varied movements in the flights. But in none of the flights did I have the adjustments so that the riders had full liberty, as I did not consider that they had the requisite knowledge and experience necessary for their safety; and hence, none of my aeroplanes were launched so arranged that the rider could make adjustments necessary for a full flight.

“This line of action caused a good deal of trouble with aeronauts or riders who had unbounded confidence and wanted to make long flights after the first few trials, but I found it necessary as they seemed slow in comprehending the important elements and were too willing to take risks. To give them the full knowledge in these matters I was formulating plans for a large starting station on the Mount Hamilton Range from which I could launch an aeroplane capable of carrying two, one of my aeronauts and myself, so I could teach him by demonstration. But the disasters consequent on the great earthquake, completely stopped all my work on these lines.* The flights that

* Since the foregoing was written arrangements have been made and capital interested for the resumption of the Montgomery experiments.

were given were only the first of the series with aeroplanes patterned after the first model. There were no aeroplanes constructed according to the two other models, as I had not given the full demonstration of the workings of the first, though some remarkable and startling work was done. *On one occasion, Maloney in trying to make a very short turn during rapid flight pressed very hard on the stirrup which gives a screw shape to the wings and made a side somersault. The course of the machine was very much like one turn of a corkscrew. After this movement, the machine continued on its regular course. And afterwards Wilkie, not to be outdone by Maloney, told his friends he would do the same, and in a subsequent flight, made two side somersaults, one in one direction and the other in an opposite,* then made a deep dive and a long glide and, when about three hundred feet in the air, brought the aeroplane to a sudden stop and settled to the earth. After these antics, I decreased the extent of the possible change in the form of wing surface so as to allow only straight sailing or only long curves in turning.*

“During my work I had a few carping critics that I silenced by this standing offer: If they would deposit a thousand dollars I would cover it on this proposition. I would fasten a 150-pound sack of sand in the rider’s seat, make the necessary adjustments, and send up an aeroplane upside down with a balloon, the aeroplane to be liberated by a time fuse. If the aeroplane did not immediately right itself, make a flight, and come safely to the ground, the money was theirs.

“Now a word in regard to the fatal accident.† The circumstances are these: The ascension was given to entertain a military company in which were many

* These performances were witnessed by thousands of people. The italics are ours.—[Ed.]

† On July 18, 1905.

of Maloney's friends, and he had told them he would give the most sensational flight they ever heard of. As the balloon was rising with the aeroplane, a guy rope dropping switched around the right wing and broke the tower that braced the two rear wings and which also gave control over the tail. We shouted to Maloney that the machine was broken but he probably did not hear us, as he was at the same time saying 'Hurrah for Montgomery's airship', and as the break was behind him, he may not have detected it. Now did he know of the breakage or not, and if he knew of it did he take a risk so as not to disappoint his friends? At all events, when the machine started on its flight the rear wings commenced to flap (thus indicating they were loose), the machine turned on its back, and settled a little faster than a parachute. When we reached Maloney he was unconscious and lived only thirty minutes. The only mark of any kind on him was a scratch from a wire on the side of his neck. The six attending physicians were puzzled at the cause of his death. This is remarkable for a vertical descent of over 2,000 feet."

In view of the extensive appropriation and utilization by others of ideas originated by him, it must be a source of considerable satisfaction to Professor Montgomery that he holds a United States patent (see Figure 260) broadly covering the combination of "wing warping" with curved surfaces*—the only sort that have ever flown.

* In the opinion of several prominent patent attorneys, there is no conflict between this patent and the earlier one issued to the Wright brothers, for the combination of "normally-flat aeroplanes" (see Page 455) with a type of "wing warping" substantially proposed by Le Bris, D'Esterno, and Mouillard, and tested, if at all, in devices that have been proved inoperative. But in all of the Wright machines that have flown, and in most other successful modern machines, there appears the combination of *curved* surfaces with "wing warping"—a direct infringement of the Montgomery patent.

A. PENAUD

An uncommonly ingenious inventor of aeronautical devices was A. Penaud, who began before he was twenty by devising the toy helicopter referred to on Page 127, and subsequently made the successful toy ornithopter mentioned on Page 120. But his most important contribution to the art was a half-ounce model aeroplane, 18 inches wide and 20 inches long, closely resembling the modern Bleriot monoplanes and embodying a remarkable system of automatic longitudinal stability. Propelled by twisted rubber bands, this model made both straight and circular flights up to a maximum length of 131 feet, at a speed of over 8 miles an hour. Subsequently Penaud was associated with a mechanic named Gauchot in a plan to build a monoplane large enough to carry two men. This machine was to have weighed 2640 pounds and have a sustaining area of 634 square feet. It was estimated that with 20 or 30 horsepower applied through twin tractor screws flight could be accomplished with an angle of incidence of 2° , at a speed of 60 miles an hour. It was planned to experiment over water to reduce the danger, but, a motor of the necessary lightness not being found, and the inventor being tormented by misrepresentation and an incurable hip disease, from which he died in October, 1880, before he had reached his thirtieth year, nothing came of a project that possessed at least the merit of being planned by one of the most able men who ever gave his attention to the subject.

PERCY S. PILCHER

Another who began experiments in his early youth was the English engineer Pilcher, whose interest in aeronautics dated from 1882, when he was aged 15, and who in 1892 commenced the construction of his first glider, closely similar to those of Lilienthal. In all he built five machines, the first of which had such pronouncedly dihedral wings that it promptly proved the futility of seeking balance by a low placing of the weight. His final and most successful type, the "Hawk" (see Figures 233 and 234), was provided with small bicycle wheels, had lightly-curved wing surfaces, and was planned to sustain a total weight of about 250 pounds—including a 2-horsepower oil engine—on an area of 188 square feet. With this machine he made one glide of 800 feet across a valley, towed kitewise at 11 miles an hour by a cord drawn by running boys, with a five-fold multiplying gear having a tractive effort that at the machine measured 30 pounds. Drawings for the necessary engine were made and study of the problem of equilibrium continued until a headlong plunge from a height of not over 40 feet, caused by the snapping of a rudder guy, resulted in Pilcher's death on October 1, 1899.

ALBERTO SANTOS-DUMONT

To Santos-Dumont, besides much activity in the development of the dirigible balloon (see Page 82), is due the credit for the first public and successful flight in a power-driven areoplane in Europe, on August 22, 1906. Following this he has been a

most daring and indefatigable worker, fortunate in the possession of both considerable ability and abundant means. The result up to the present time has been the evolution of one of the lightest and most successful monoplanes in existence (see Figure 221), which with characteristic unselfishness its designer has placed on the market at cost, and refrained from monopolizing it by patents.

F. H. WENHAM

Mr. F. H. Wenham, who died so recently as August 11, 1908, was unquestionably the originator of the biplane and other superimposed multisurface constructions, which were subsequently developed by Hargrave into the box kite, and which are so conspicuous a feature of many modern aeroplane designs. This construction he patented in England in 1866, in which year he also presented the idea in a paper read at the first meeting of the Aeronautical Society of Great Britain.* Despite the merits of the idea, and its subsequent successful utilization by many inventors, no practical application of the construction ever was made by its originator.

WILBUR AND ORVILLE WRIGHT

Commencing in 1900, Wilbur and Orville Wright, two bicycle repairmen of Dayton, Ohio,

* In this paper, which has become a classic on the subject, the most interesting portion is as follows: "Having remarked how thin a stratum is displaced beneath the wings of a bird in rapid flight, it follows that, in order to obtain the necessary *length* of plane for supporting heavy weights, the surfaces may be superposed, or placed in parallel rows, with an interval between them. A dozen pelicans may fly one above the other without material impediment; as if framed together; and it is thus shown how two hundredweight may be supported in a transverse distance of only ten feet."

and the sons of Bishop Wright of that city, began devoting a large portion of their time to the serious development of such previous aeronautical knowledge as they found available, their first interest in the subject having been awakened by flying toys years before, and a fresh impetus having been given it by the death of Lilienthal, which directed attention to his work, in 1896. Proceeding with the sound idea that actual practice in the air was the surest road to success, an idea that had been fully appreciated but little realized by others, the Wrights levied upon every possible source of information and, frankly commencing with Chanute's help and a modification of the Chanute biplane glider, which they regarded as the most advanced construction existent at the time, they entered upon a deliberate, unremitting, and enthusiastic prosecution of an at first thankless task, which for sturdy perseverance in the face of obstacles and sensible disregard of ignorant opinions, has few parallels in the history of invention.

Having from the outset more faith in experimental than in analytical methods, the Wrights set themselves first to the task of confirming or correcting the various formulas of their predecessors concerning wind pressures, the sustaining effects of different inclined surfaces, etc. Progressing from these to the various possible methods of steering, and of maintaining lateral and longitudinal balance, they tirelessly tested a constantly improving series of constructions by hundreds of kite and gliding experiments conducted among the sand

dunes near Kitty Hawk, North Carolina. Having thus secured an amount of practice that enabled them to make reasonably safe gliding flights of considerable length in calms and moderate winds, they next undertook the application of a motor, naturally turning to automobile mechanism as the most promising source of a suitable power plant. This resulted, on December 17, 1903, in four flights in calm air with a gasoline engine, the longest of which, however, was of only 852 feet—shorter than many of Lilienthal's glides prior to 1896, hardly a fourth as long as the flight of Langley's model on May 6, 1896, and not quite as long as the flight of Ader with his "Avion", on October 14, 1897. On March 22, 1903, a United States patent was applied for on a wing-warping device, in combination with flat sustaining surfaces, indicating either a failure at this time to appreciate fully the absolute importance of definitely and correctly curved surfaces, or else constituting a lack of the "full disclosure" demanded by patent law. The construction described in the patent specifications (see Figure 259) being obviously inoperative, these were repeatedly objected to and rejected by the patent-office examiners, and it was not until May 22, 1906, that the claims were allowed—even then on the basis of an inoperative construction.

Throughout 1904 the Wright experiments continued, surrounded by the utmost secrecy, but it is definitely attested by Chanute that during this year they increased the length of their longest flight to 1,377 feet.

It was not until nearly the end of September, 1905, months after Montgomery's flights in the Santa Clara Valley and publication of his construction, and some time after his patent was applied for, that the Wrights commenced to be conspicuously successful—with parabolically-curved sustaining surfaces and a system of wing-warping closely resembling that of Montgomery's patent and not at all like that claimed in the Wright patent (see Figure 260). Following these successes, which though well authenticated were kept out of the newspapers and well away from the general public, vigorous but quiet efforts were made during 1906 and 1907 to sell to European governments, not patent rights, but "secrets" of construction. Little success resulting, because of the terms and conditions that were stipulated, and European aviators having by this time progressed to the point of making long flights, this policy was abandoned late in 1908, and the Wrights came out into the open with their machines—Orville Wright in the United States and Wilbur Wright in France—with the result that they were quickly able to establish new distance and duration records, which stood for nearly a year. At the present time, however, the Wright machine does not hold a single distance, duration, speed, weight-carrying, cross-country, or altitude record in the world, and has borne out the rather numerous critics of its construction by being responsible for an undue proportion of the accidents that have occurred in the history of power-propelled heavier-than-air machines.

VOISIN BROTHERS

In the course of the early Bleriot and Archdeacon experiments over the Seine with towed and free gliders during 1904, much of the most successful construction and designing work was done by Gabriel Voisin, a young French engineer who subsequently, in association with his brother, of the firm now known as Voisin Freres, and of their engineer, M. Colliex, designed the excellent machines of box-kite type with which Farman and Delagrange electrified the world by their flights in the latter part of 1907 and the forepart of 1908. The Voisin machines, which, while not without serious shortcomings, possess a considerable degree of automatic stability, are the prototypes of the highly successful Farman machine.

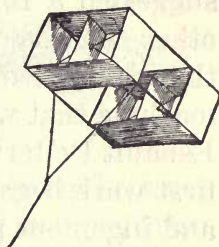

MISCELLANEOUS

In addition to the foregoing, those among the world's aeroplane designers who are most worthy of mention are Alexander Graham Bell, inventor of the telephone and founder of the Aerial Experiment Association, and whose tetrahedral kite is a construction of great originality and interest; S. F. Cody, designer of one of the most successful man-lifting kites, and whose biplane (see Figure 202) is the largest and one of the most successful aeroplanes that has ever flown; Glenn H. Curtiss, whose flights with the "June Bug" and "Silver Dart"

of the Aerial Experiment Association, and with machines of his own, entitle him to front rank among aviators; Danjard, who in 1871 designed what was perhaps the first double monoplane, which proved unsuccessful chiefly because of the lack of a suitable motor; Count D'Esterno, who in 1864 wrote a remarkable pamphlet in which he suggested a form of wing warping and proposed other details since proved of practical value, though he died in 1883, before the completion of a machine that was then under construction; Robert Esnault Pelterie, the young French engineer whose first work began some years ago and whose speedy and ingenious monoplane is regarded as one of the most successful and promising of present machines, besides which it has sustained the highest weight per unit of area of any machine yet flown successfully; Henry Farman, whose early flights with the Voisin machines, subsequent development of this type into the first aeroplane to employ both wheels and runners in the starting and alighting gear, and his recent record achievements, have definitely contributed to progress; Captain Ferdinand Ferber, of the French army, who ranks equally high as a pioneer worker, as an authority on both heavier-than-air and lighter-than-air craft, and as a writer on the subject of aeronautics, and whose tragic death some months ago is one of the heaviest tolls yet exacted for aeronautical advancement; Laurence Hargrave, whose invention of the box kite and wonderful work with ornithopter propulsion have in a measure overshadowed his discoveries

concerning the aeroplane proper; Henson, whose immense, 3000-pound aeroplane built in 1842, embodied a large proportion of the features since proved needful, and turned out a failure more because it was too much in advance of its time than for any other single reason; A. M. Herring, whose early association with Chanute and recent association with Curtiss at least entitles him to recognition; Captain Le Bris, whose reputed astounding flight in



FIGURE 36.—Le Bris' Glider.

France with a wing-warped machine in 1867 almost staggers belief (the Le Bris glider is illustrated in Figure 36); M. Levavasseur, whose Antoinette monoplanes are among the finest present-day fliers and are certainly the most graceful, and whose fuel-injection motors have been used to a greater or less extent in nearly every modern European aeroplane of demonstrated quality; Linfield, who in 1878 conceived the ingenious plan of testing the lift of an aeroplane by hauling it on a railway flat car, and thus caused it to rise clear—though without contributing anything to the solution of equilibrium; Michael Loup, who in 1852 had fully developed the wheeled starting gear; Hiram S. Maxim, whose exhaustive and expensive experiments in 1894 gave definite solution of the power and lifting problems, though they were of little help to seekers after efficiency and equilibrium; Louis Pierre Mouillard, whose "L'Empire de l'Air", published in 1881, is one of the great

classics of aeronautical literature, whose gliding flights in Egypt are not without interest, and whose United States patent (see Figure 262) shows a tolerably clear appreciation of one type of wing warping; Thomas Moy, who in 1875 got 12 miles an hour—on the ground—by the thrust of the propellers of his “aerial steamer” (see Figure 37);

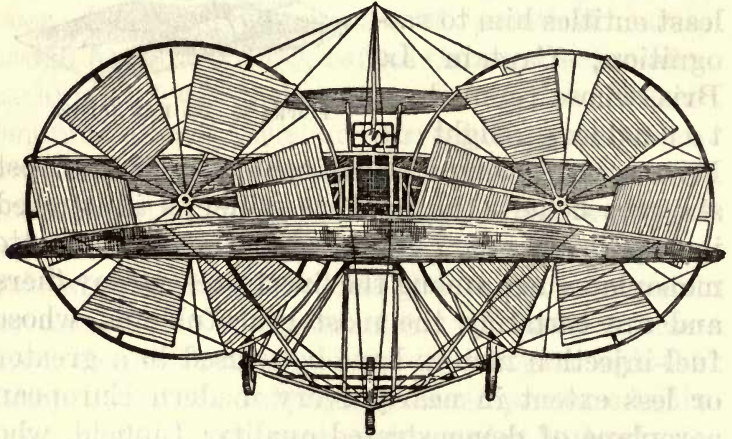

FIGURE 37.—Moy's Aerial Steamer. Tested on a track in the Crystal Palace, London, in June, 1875. Six-foot propellers. Steam engine, $2\frac{1}{4} \times 3$ -inch cylinder, developing three horsepower at 550 revolutions a minute. Engine weighed 80 pounds, with boiler. Car ran on three small wheels. Speed of 12 miles an hour proved insufficient to lift.

Horatio Phillips, who in the years from 1884 to 1891 by empirical methods went more deeply into the question of correct wing sections than any previous investigator and then produced slat-like multiplane models of extraordinary lifting capacities; Stringfellow, who in 1868 built the first triplane (a model) and afterwards produced a steam-engine that developed one horsepower within 13

pounds of weight, achievements that he was following up by the construction of a man-carrying machine, which was left unfinished at his death in 1883; Victor Tatin, who made in 1879 the first model aeroplane that lifted itself by a run on the ground, and who at a recent date was working on a modern aeroplane for the Clement-Bayard concern, in France; and Vuia, who in 1906 designed one of the earliest of the really modern monoplanes, and accomplished a few very short flights towards the end of this year and during 1907.

CHAPTER FOUR

AEROPLANE DETAILS

Passing from the contemplation of the broader possibilities and problems of human flight to consideration of the means by which such flight is to be accomplished is necessarily a transition from the general to the particular.

Aeroplanes, for example, are vehicles involving sustaining surfaces of suitable form, provided with means for propulsion, for the maintenance of equilibrium, and for steering in different lateral and vertical directions. Evidently the provision of these different elements can be carried out in a great variety of ways, which being the case it is possible to work towards the more perfect designs only by two policies—one requiring study of the laws involved in flight and the application of these laws in suitable mechanisms, and the other involving observation and copying of the flying mechanisms of nature. Both of these policies are beset by tremendous difficulties—the first because of the exceedingly complex factors of the problem, and the second because there is no bird that approaches in size or weight the smallest man-carrying vehicle.

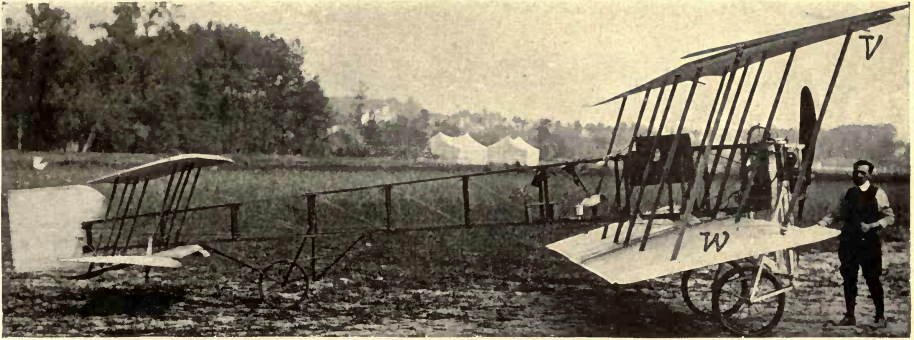

FIGURE 69.—Goupy Biplane. In this the placing of the surface *v* in advance of the surface *w* is intended to cause the air-currents to meet the surfaces in such a manner as to secure greater lift from the upper surface than is secured in biplanes in which it is placed farther back. That flatness of the surfaces is quite erroneous, though perhaps not the only reason the machine failed as a flier.

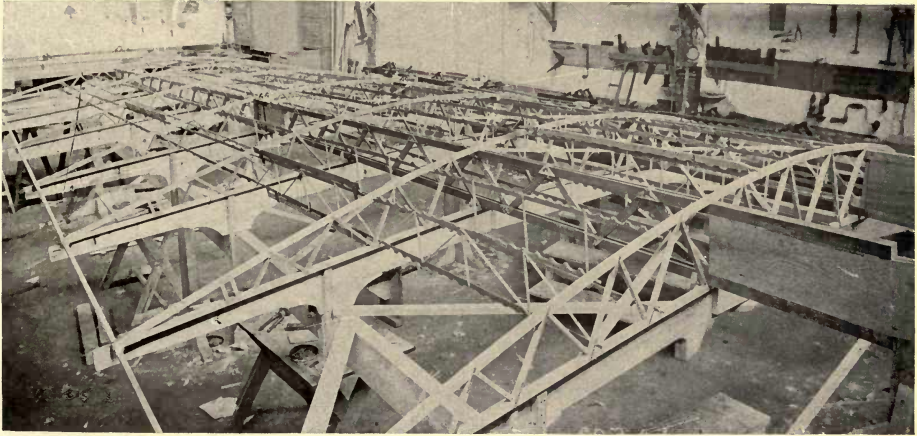

FIGURE 71.—Internal Framing of Antoinette Monoplane Wing.

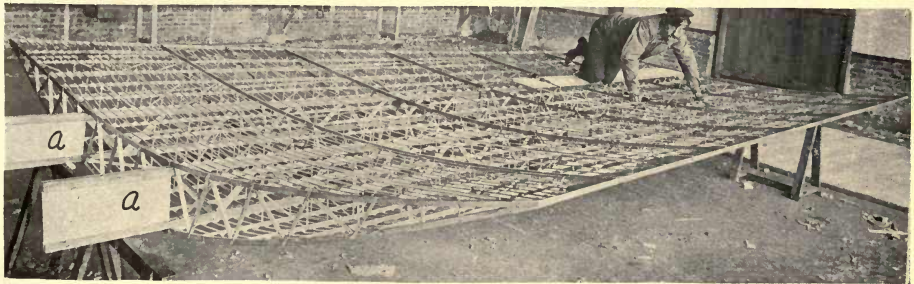

FIGURE 72.—Framing of Antoinette Wing Inverted. The load is supported on the two main girders *aa*, which are connected by a maze of crossbraces to the transverse ribs and secondary longitudinal members.

ANALOGIES IN NATURE

Besides constituting the most conclusive evidence imaginable of the perfect practicability of flight, as well as serving as the original and a constant stimulus to man in his efforts to achieve navigation of the air, the birds and other animals that fly afford models that naturally merit the most thorough and profound consideration of all students of aerodynamics. For in nature's mechanisms of flight must exist answers to all the problems of flying, awaiting for their discovery only the analyses and applications of sufficiently persevering and painstaking investigators.

From the facts of animal flight there are certain broad deductions to be made at the outset. Perhaps the most impressive of these is the evident fact that there is more than one way and more than one type of mechanism that can be made to serve the purpose. There are the common flapping flight, the less-common soaring flight, and the flight of the wing-case insects, while in the way of structural variety it is a broad range from the tissues of insect wings, the furred skin folds of the flying squirrel, and the membranous integuments of the flying fishes, bats, etc., to the feathered perfection of the wing of a humming bird or condor.

The size of flying animals also is a point of interest. Perhaps the heaviest of the soaring fliers is the California vulture, similar to but in its largest specimens larger than the largest speci-

mens of the Andean condor, and not uncommonly weighing as much as 20 pounds. Turkeys are said sometimes to weigh twice this, while the albatross is occasionally found of a weight of 18 pounds. Still heavier than these may have been the extinct pterodactyl, which it is more than probable, however, weighed no more than 30 pounds. No flying creature that ever existed appears to have been as heavy as the combination of a man with the lightest structure that can be made to support him, and this fact often has been cited as an argument against the possibility of human flight, having been advanced as conclusive by no less an authority than the late Simon Newcomb. But in this connection it is a significant fact that the areas and the power required to support a given weight steadily *decrease* in passing from the smaller flying animals to the larger. This point, so favorable in its bearings on the problems of human flight, is not wholly due to any single cause, though probably the main factors are the effect noted on Page 184, and the escape of air around the edges of wing surfaces— such edges being necessarily longest in proportion to the area in the smaller sizes, it being a geometrical axiom that the length of boundary of any given shape of surface increases in direct ratio with increases in linear dimensions, whereas areas increase with the square of these dimensions. Thus a square one by one, equalling one square unit of area, has four linear units of edge—one foot to each one-fourth of a square unit of area, whereas a square two by two, affording four square

units of area, has only eight linear units of edge—one to each one-half of a square unit of area.

The weights, weight supported per unit of wing area, horsepower, pounds supported per unit of area, and pounds supported per horsepower, in the cases of different flying creatures and successful aeroplanes, are given in tabular form on the next page.

FLYING FISH

Flying fish, which are found in all the warmer seas, are capable of maximum flights of only a few hundred yards—usually at a height of not over fifteen feet—by a method of progression that is decidedly peculiar and, in some respects, sufficiently mysterious to lead to controversy amongst different observers. It is generally supposed that the flight is of the true gliding type, dependent altogether upon the force of the initial impulse of the tail in the rush out of the water when these creatures are pursued by any of their numerous enemies, but there are not lacking those who stoutly assert that there is on occasion a true flapping flight. This has been explained by others as a fluttering of the great pectoral fins into successive wave crests, to keep the membranes from drying in long flights. It is also commonly stated that flying fish go much farther against the wind than with it—which if true at once involves the difficult and little understood phenomena of



FIGURE 38.—Flying Fish.

TABULAR COMPARISON OF FLYING ANIMALS AND AEROPLANES.

	Weight (in pounds)	Wing Area (square feet)	Horse- power	Pounds to Square Foot	Pounds per Horsepower
*Cabbage Butterfly	.000169	.00942		.0179	
Gnat	.0000006	.00003		.0204	
*Maiden Dragon Fly	.000423	.01415		.0298	
Swallow-Tailed Butterfly	.000718	.01137		.0631	
Flat-Bellied Dragon Fly	.00128	.0135		.0948	
House Fly	.000021	.000183		.1147	
Small Bat	.0078	.0507		.153	
Cockchafer				.195	
Stag Beetle (female)				.214	
Sphinx Moth	.00405	.01892		.2140	
Stag Beetle (male)				.266	
Rhinoceros Beetle				.318	
Swallow	.038	.1116		.349	
Honey Bee	.000156	.000396		.3939	
Screech Owl				.424	
Short-Eared Owl				.446	
Swift	.0708	.1462		.484	
Raven				.535	
Humming Bird	.015	.026	.001	.577	15
Langley Double Monoplane	30.	52.	1.5	.577	20
*Laughing Gull				.62	
Glossy Ibis				.649	
Sparrow	.059	.0791		.747	
Pülcher Glider (the "Gull")				.75	
Goshawk				.763	
*Sparrow Hawk	.549	.69		.79	
Bumble Bee	.00093	.00104		.8042	
*Herring Gull	2.18	2.41		.9	
Flyhawk				.926	
Crow	1.25	1.3		.96	
Dove	.619	.617		1.	
*Stork	4.78	4.57		1.04	
*Scavenger Vulture				1.052	
*Turkey Buzzard				1.052	
*White Pelican				1.052	
Montgomery Monoplane Glider	200.	185.		1.08	
Thrush	.211	.188		1.12	
Lilienthal Biplane Glider	200.	170.		1.18	
*Pterodactyl	30.	25.	.036	1.2	†833
Wright Biplane Glider	238.	290.		1.22	
Wright Biplane Glider	210.	160.		1.31	
*Sea Eagle	10.57	8.05		1.31	
Pülcher Glider (the "Hawk")	215.	165.		1.33	
Pigeon	1.	.7	.012	1.429	83
*Griffon Vulture				1.456	
*Eared Vulture				1.456	
Curtiss Biplane	550.	350.	25.	1.57	16
*Condor	17.	9.85	.043	1.726	†395
*Flying Fox	2.91	1.65		1.76	
Roe Triplane	540.		9.		60
*Flamingo				1.818	
Voisin Biplane	1150.	597.	50.	1.93	23
Farman Biplane	800.	410.	45.	1.95	17
Partridge	.87	.34		1.97	
Wright Biplane	1200.	560.	25.	2.04	48
Cody Biplane	2000.	950.	80.	2.1	25
Lilienthal Monoplane Glider	180.	85.		2.11	
Antoinette Monoplane	730.	324.	50.	2.25	15
Pheasant	2.11	.89		2.37	
Wright Biplane	1200.	450.	28.	2.66	43
Voisin Biplane	1540.	537.	50.	2.86	31
Antoinette Monoplane	1110.	370.	50.	3.	22
*Albatross	25.36	8.12		3.12	
Bustard	20.29	6.02		3.36	
R. E. P. Monoplane	933.	168.	30.	5.55	31
Wild Goose	9.	2.65	.026	3.396	†346
Santos-Dumont Monoplane	400.	115.	35.	3.47	11
Bleriot Monoplane No. 11	715.	150.	35.	4.76	11
Bleriot Monoplane No. 12	1100.	216.	30.	5.1	36

*Soaring Flyers. †Note the great efficiency of the bird mechanism.

soaring flight. An exceedingly interesting fact about flying fish is that they present the only examples in nature's fliers of the use of vertical surfaces—presumably to afford automatic lateral stability (see Page 209). The largest flying fish are about 18 inches long (see Figure 38).

FLYING LIZARDS

The Malayan gecko, or "flying dragon", is a curious creature, the habits of which are little known. It is provided with loose membranous expansions along the sides of the body which are supposed to enable it to make long gliding leaps, like those of the flying squirrels. A commoner lizard of East India has loose folds of skin that are distensible by several movable ribs. Neither of these animals attains a length of more than eight inches.

FLYING SQUIRRELS

The common flying squirrel is a very small nocturnal species with a feather-like tail, and folds of skin on either side capable of being stretched out and controlled in such manner by the legs that 60-foot glides from treetops are made in safety. There are much larger but less known species in California and Alaska that undoubtedly can glide from trees 200 feet high.

FLYING LEMUR

The flying lemur, the "colugo" of the East Indies, has a very loose skin with peculiarly sleek fur, enabling it to make long sailing leaps like the

flying squirrel. It is a slender creature 18 inches long, and is much the largest and heaviest of the several animals that glide in this manner.

FLYING FROG

An animal of which there has been little if any accurate observation is the flying frog—a Malayan

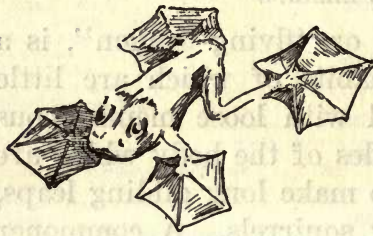

FIGURE 39.—Flying Frog. Without being confirmed by observation, it nevertheless appears obvious that this curious creature can maintain its lateral and longitudinal balance only by differential tilting of the side pairs of feet in the first case and of the front and rear pairs in the second.

tree-dwelling frog that is supposed to sail down from the tree tops in long slanting flights. Its feet are very large and webbed between the toes (see Figure 39).

It is peculiarly interesting as a perfect example of correct methods of maintain-

ing lateral and longitudinal balance by the manipulation of a plurality of separated surfaces (see Page 215).

SOARING BIRDS

The phenomena of soaring flight has long been a mystery to students of the subject, having baffled the most eminent physicists in attempts to explain it and defied the most painstaking observers to disprove its existence. For these reasons the effortless travel of the soaring birds, the largest and practically the heaviest of all flying creatures, is regarded as the ultimate achievement in aerial navigation—to be attained by man, if at

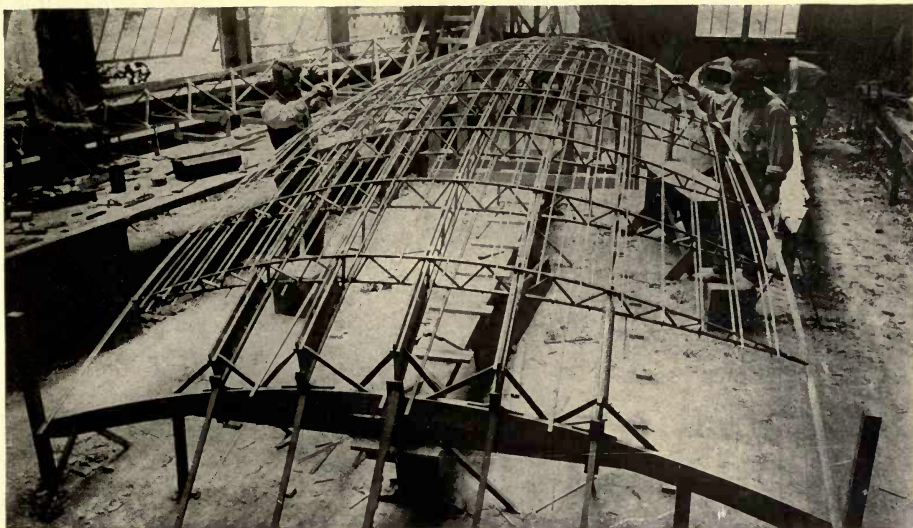

FIGURE 73.—Frame of Bleriot Monoplane Wing. In this wing the longitudinal supporting members are five in number, with cross bracing and curved ribs similar to those used in the Antoinette machine. The curvature is given to the ribs simply by straining them into place as the structure is put together, there being no preliminary bending.

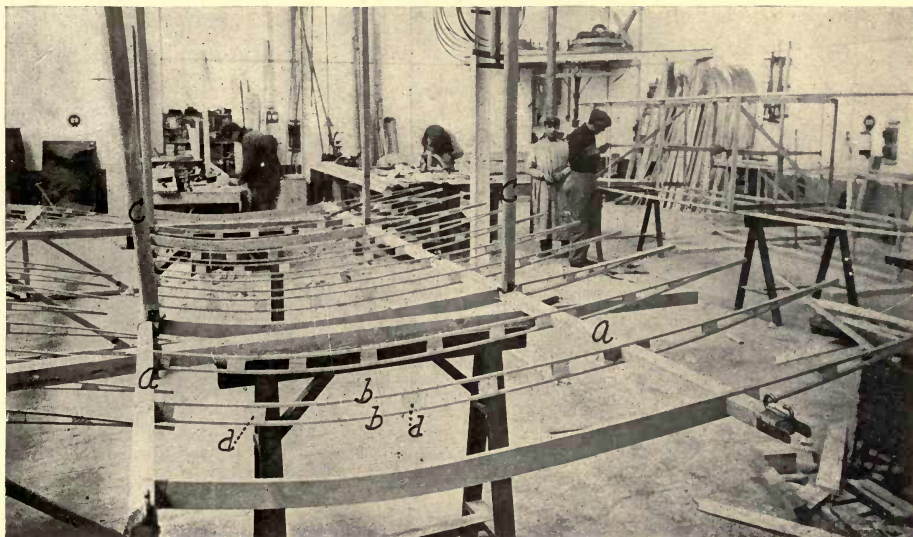

FIGURE 74.—Inverted Upper Wing Frame of Wright Biplane. This frame is inverted on supports for the convenience of men working upon it. It is to be noted that each rib is made of two light strips *bb*, which are spaced apart by the wing bars *aa* and by the small spacing members *dd*. The rib in the foreground is made solid because it forms the end of a section of the wing, which attaches to an adjacent section by the small clamping plates on the ends of the wing bars.

all, only upon a complete and perfect understanding of laws that neither fit into nor follow from many of the accepted conceptions of force and motion (see Page 169). In the table on Page 162 the soaring birds are designated with stars—*. The most conspicuous features to be discerned in a study of soaring-bird forms are the usually extreme length and narrowness of the wings, the lower sustentation per unit of area than prevails with flapping fliers, and a pronouncedly different type of curvature to the wing sections.

SOARING BATS

Most of the bats are flapping fliers, but the "flying fox", or "kalong", of Java, which is one of the largest of its kind, sometimes measuring 5 feet from tip to tip, practises true soaring flight. This fact is of interest chiefly in that it refutes the assertions of the few theorists who contend that soaring flight requires for its accomplishment a supposed imperceptible movement of feathers.

THE PTERODACTYL

This bird-like reptile (see Figure 40), which is known only from the discovery of fossil remains in strata of the Cretaceous period, measures in ordinary specimens about 20 feet from tip to tip. It must have been, however, very light, the wing bones that have been found being mere shell-like tubes of large diameter and extreme thinness. The fact that there once existed a larger flying animal than any now extant has been held to prove

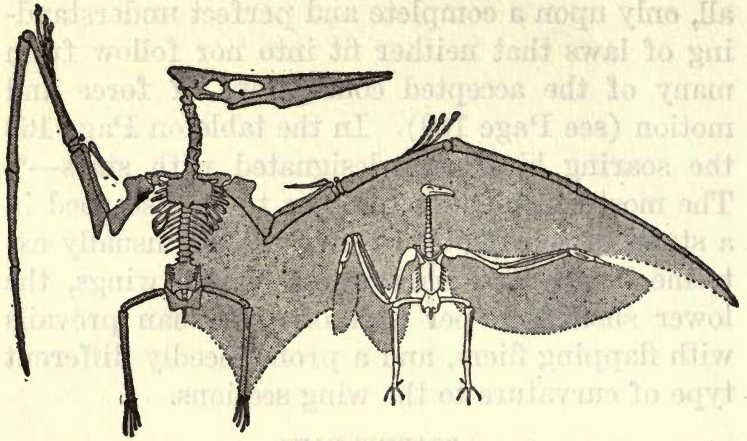

FIGURE 40.—Comparison of Pterodactyl and Condor. The extinct pterodactyl, a great flying reptile the fossilized remains of which have been found in strata of the Cretaceous period, is the largest flying creature of which we have any knowledge. Its wing spread was 20 feet, but its maximum weight was possibly not over 30 pounds.

a greater density to the earth's atmosphere in pre-historic times, but this theory is neither necessary as an explanation nor borne out in the evidence.

FLYING INSECTS

It is surprising how generally students of flight have overlooked that fact that in certain insects there seems to be an exceedingly close parallel to

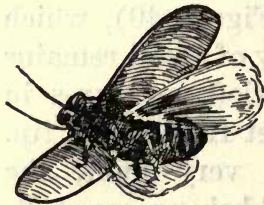

FIGURE 41.—Wing-Case Insect.

modern aeroplane constructions, in which there appears primarily a sustaining surface moved through the air at an angle of incidence and secondarily a separate propelling element. This combination is peculiar to insects with "wing cases", of the order *coleoptera*, in which

during flight the wing covers are rigidly extended at right angles to the line of movement, while the under wings are rapidly vibrated to produce propulsion, as is suggested in Figure 41. The largest known insects that use this mode of flight have a wing span of not over 6 inches.

MONOPLANES

This general type of supporting surface, being that used by all flying animals, is on this ground reasonably to be regarded as the superior form, besides which it is a safe assertion, despite various conspicuous successes that have been achieved with biplanes and occasional triplanes, that at the present time no aerial vehicle ever built has afforded results more promising or significant than those apparent in the remarkable equilibrium and extraordinarily-flat gliding angles of the Montgomery machine (see Page 139), and in the high sustentation per unit of area in the Bleriot and R. E. P. machines (see Page 162).

For reasons that are elsewhere explained herein (see Pages 168 and 169), a monoplane will afford more sustentation per unit of surface than can be expected from each of two or more similar surfaces placed one above the other—unless an altogether impracticable amount of separation be used.

The chief objection so far urged against the monoplane is the supposed difficulty of staying the wing surfaces properly, the trussed construction of the biplane naturally being not available. Yet one has only to examine the internal trussing of

the Antoinette monoplane (see Figures 71 and 72), or the simple staying of the Bleriot and Montgomery wing surfaces, to realize that with this construction there are ways and means of achieving results quite as successful as any that can be had with others.

MULTIPLANES

The first suggestion of the multiplane was made by F. H. Wenham, in his paper read at the first meeting of the Aeronautic Society of Great Britain, in 1868, which is quoted on Page 149.

It is obvious that any number of superimposed planes can conceivably be used, as was suggested in the decidedly freakish "Venetian-blind" construction of Phillips (see Page 157), but so far the most successful results have been obtained with not more than two planes, this number affording all the possible advantages of trussed construction with a minimum of its disadvantages. It is a serious though at the present time little regarded objection to multiplanes that they increase the necessity for always maintaining headway to maintain sustentation. Thus, if a biplane starts to drop vertically, in its normal position, it can oppose only half of its total area to resist the fall. Carried to its extreme the result must be something like the Phillips slat-like machine, which without forward movement would drop like a brick. On the other hand, the Montgomery monoplane glider can be released in the air wholly without forward movement, in which case it simply settles slowly

as it commences to glide. Much the same is true of any monoplane, unless the loading per unit of area is carried to extremes.

BIPLANES

The biplane is of particular interest as being the type of machine with which Lilienthal was experimenting when killed, the type of glider with which Chanute attained the greatest success, and the form of flying machine which has developed to a high degree in the Wright, Voisin, Curtiss, and Farman constructions—not to mention the close and significant analogy it finds in the box kite.

MORE THAN TWO SURFACES

The only multiplanes that ever have accomplished any really successful flying at the present writing are the Vaniman triplane and the Voisin-Farman triplane, the latter illustrated in Figure 211. Both have been, however, discarded for returns to the biplane construction.

FORMS OF SURFACES

It is perfectly evident to any one of most ordinary engineering attainments that the only possible complete and thoroughly logical method of treating the subject of wing forms and related air reactions is the mathematical, but since aerodynamics involve perhaps the most difficult, obscure, and least-investigated and understood of all the phenomena of force and motion, it is out of the question in the present state of the science to offer

final and definite explanations of principles involved. The most that may be reasonably attempted is to marshal connectedly the empirical deductions that have been reached, to state the few generalizations that seem reliable, and to give space to the opinions of the most advanced authorities on the subject.*

Certainly it must become evident upon the most casual investigation—upon the least reading of the great mass of speculation and attempted analyses of aerodynamic reactions—that nearly all of the workers in this field have been struggling in the dark, and that their conclusions, when not wholly worthless, are as a rule to be accepted only in part or with many reservations. An example of this appears in a recent issue of a well-known aeronautical journal, in which there appears an article by a writer evidently well-versed in modern physical science and related modes of mathematical reasoning. Yet, at the end of a labored dissertation—in which it is attempted to show that the arc of a circle traveling along a line tangent to the advancing edge is the correct section for a wing surface (in the face of the fact that no successful natural or artificial flier uses this curve or setting—instead of

* Since the foregoing was written, the author has been placed in a position to announce that important laws of aerodynamics have been fully formulated by Professor Montgomery, and have been put to complete and most remarkably successful tests in the way of experimental verification and confirmation. These investigations, a part of which are only briefly outlined in Pages 173 to 203, inclusive, will in the near future be submitted to the consideration and criticism of the world. The writer confidently predicts that they will not only amaze by the originality and completeness of the researches and analyses involved, but will also, by application of their profound principles, vastly advance the science of aerial navigation.

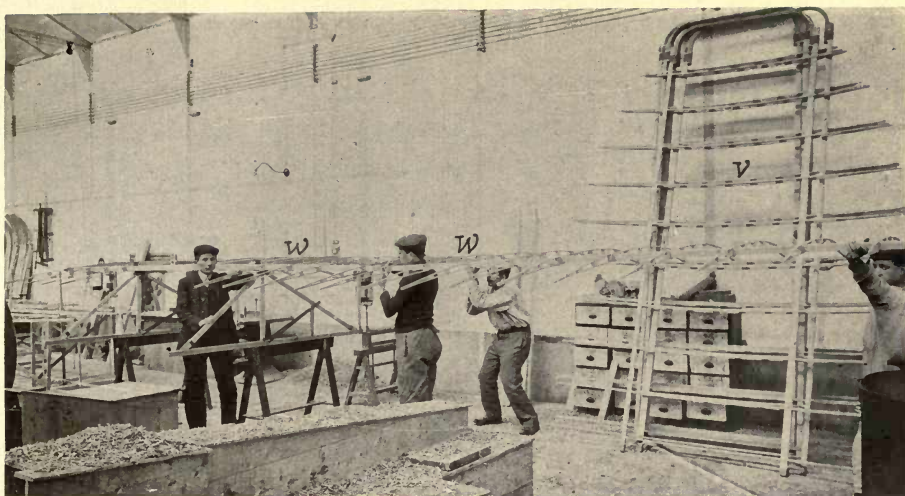

FIGURE 75.—Assembling Wright Wing Frames. The complete biplane is made in three portions, the center section slightly overhanging the two runners—between which stands the man at the left of the view. This section has attached at each end a section like that at *w*—shown at the moment of attachment. Similar sections are leaning against the wall at *v*.



FIGURE 76.—Aileron Control of Lateral Balance in Antoinette Monoplane by manipulation of the two hinged tips *aa*.

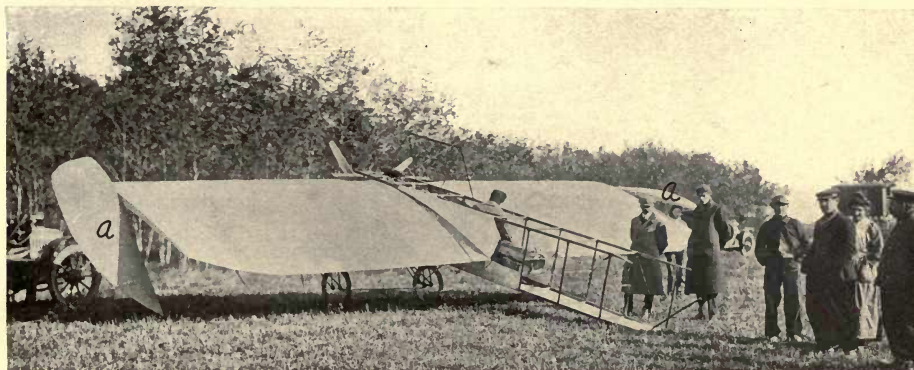

FIGURE 77.—Bleriot Monoplane VIII. The feature of this machine was the control of lateral balance by the pivoted ailerons *aa*.

coming to the definite conclusions one would naturally expect as a result of the mathematical method the whole question is characteristically begged in this wise: "We cannot follow clearly the pressures and motions that take place when a surface travels obliquely through the air—because they are very involved", as if there could be any possible occasion for a technical treatment of the subject that should not in some measure dispel the confusion that surrounds it.

FLAT SECTIONS

As the most elementary possible conception it is quite natural that many among the earlier and even some more recent aeroplane experiments should have involved the use of flat surfaces. It is

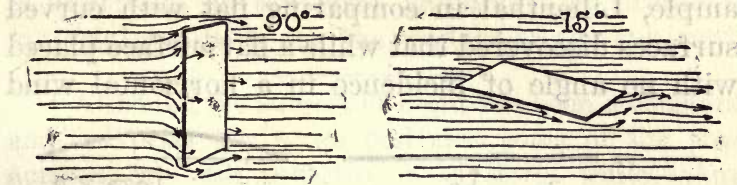

FIGURE 42.—Pressure on Vertical and Inclined Surfaces. In an air current of 25 miles an hour the surface at 90° receives a pressure of 3.24 pounds to the square foot, while the surface inclined 15° from the direction of the current receives a pressure of only .33 pounds, and at the same time affords an upward lift of 1.5 pounds.

now proved, however, that such surfaces are quite ineffective as compared with curved surfaces.

Though useless for sustentation in any practicable aeroplane construction, except by wasting enormous excesses of power, a flat surface well illustrates a basic principle of sustentation by moving an inclined surface through the air, as is shown in Figure 42.

CURVED SECTIONS

The sections of all animal wings being more or less curved it is a fairly direct conclusion that there are important reasons behind the use of such formations—a conclusion that becomes stronger the more the subject is studied.

Arcs of Circles, as affording curved surfaces of comparatively simple character, were the first tried by early dissenters from the idea of flat surfaces. Their use, while neither as scientific nor as successful as that of other curves, will afford fair results under certain conditions, but far more important than any success that has attended their use has been their influence in suggesting further deviations from preconceived opinions. For example, Lilienthal in comparing flat with curved surfaces discovered that while a flat surface placed with no angle of incidence in a horizontal wind



FIGURE 43.—Comparison of Plane and Arched Surfaces Without Angle of Incidence. Lilienthal found that while the lift of a flat surface placed as above was zero, the arc of a circle gave a lift equal to 52 percent of the pressure upon it when exposed in a vertical position to the same wind.

afforded no lift, as would be expected, a circular arc placed in the same position gave a lift equal to 52% of the normal pressure on the same surface held vertically in the same wind! This phenomenon, which is illustrated in Figure 43, is to be explained only by there being an effect of the surface on the air currents *in advance of the surface*—realization of which is at the basis of all suc-

cessful work in aeronautics and all correct reasoning upon its problems. (See Page 174).

Parabolic Surfaces, with minor modifications (to suit certain practical exigencies) into approximations of other of the conic sections and other curves, have been proved experimentally and can be demonstrated mathematically to be the correct curves for wing sections. In an empirical way this was first deduced by Lilienthal and Phillips, while exact examination proves it to be a principle involved in the curve of birds' wings, but it has remained for Montgomery to discover the laws involved. These are deemed of such importance that the following popular outline of the principles involved in the formation of wing surfaces is reprinted as the most valuable and practical material available for the student of the subject.*

“Although the subject of flight has been a constant and universal study, we find that some of the phenomena are still involved in mystery, while many others present only unexplained anomalies. This of itself would suggest the question: have the fundamental principles or laws been formulated?

“From what I have gleaned from the writings of the various students I believe they have not—this for

* This paper, which was revised in 1907 for presentation to the International Aeronautical Congress, and subsequently published in “*Aeronautics*,” under the title of “Principles Involved in the Formation of Wing Surfaces and the Phenomenon of Soaring,” is an amplification of an article by Professor Montgomery, entitled “New Principles in Aerial Flight,” which appeared in the *Scientific American Supplement* of November 25, 1905—some months after the first trials with the Montgomery glider in California. Much earlier than this, in 1895, substantially the same material was submitted by Montgomery to Octave Chanute.

the reason that because of the apparent simplicity of the phenomena we are tempted to take too much for granted and have been misguided in our trend of thought. My own studies and investigations have forced me to the conclusion that in flight we have a special and unique phenomenon, which for its comprehension requires something more than the simple suggestions offered by the study of surfaces acted upon by the moving air, just as the action of the gyroscope presents special phenomena which are in advance of our first ideas of rotation.

“Having this view of the subject I am forced to present it in its entirety, as I have been unable to find any researches of others to which I could add mine as an amplification, and, while brevity forbids that I should enter into the many points involved, I desire to make use of such as seem to constitute a direct and complete line of demonstration, using some well known phenomena and principles and developing them in the lines peculiar to this problem.

“At the Aeronautical Congress of 1893, in Chicago, it was my privilege to call attention to some phenomena that I had noted, the most significant of which is this: *A current of air approaching an inclined surface is deflected far in advance of the surface, and approaching it in a gradually increased curve, reaches it at a very abrupt angle.** This phenomenon is the basis of the observations and studies that I desire to present to your Congress.

“In the idea of deriving support by moving an inclined plane through the air, the first conception is

* The italics are ours. This exceedingly early recognition by Montgomery of this fundamentally-important phenomenon, still little appreciated by many modern investigators, is alone enough to establish its discoverer as one of the pioneers of successful modern aeronautics.

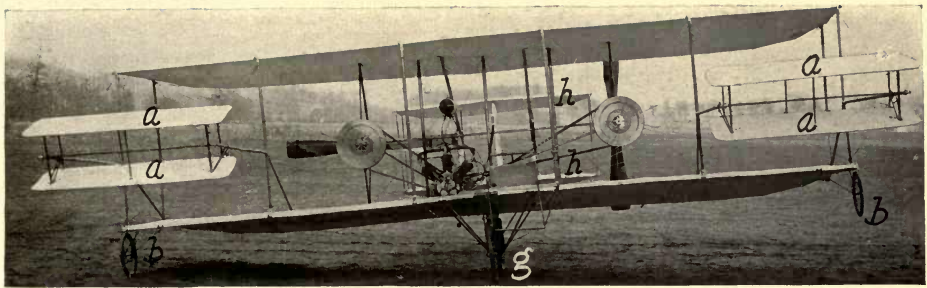

FIGURE 78.—Lejeune Biplane, with forwardly-extended ailerons at *aaaa*, for maintaining lateral balance.

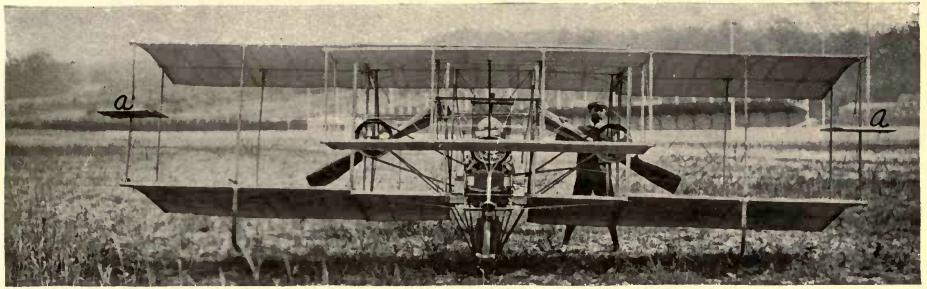

FIGURE 79.—Front View of Pischoff and Koecklin Biplane, with aileron controls at *aa*.



FIGURE 80.—Side View of Pischoff & Koecklin Biplane, showing one of the ailerons very clearly at *a*. The ingenious system of controlling the forward elevator *hh* by direct connection of the steering rod *e* to the steering pillar *o* is of interest.

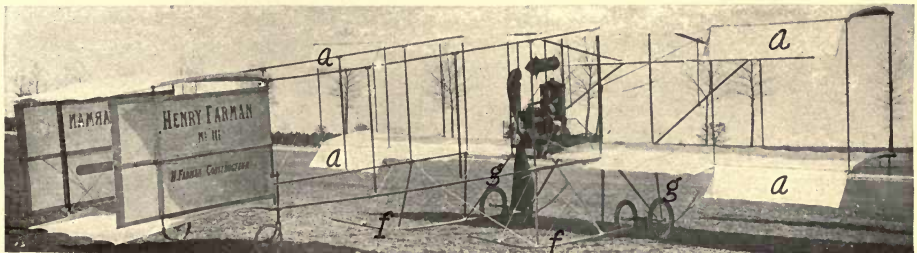

FIGURE 81.—Aileron Control of Farman Biplane. The four hinged ailerons are shown at *aaaa*.

the reaction of a mass meeting or impinging upon the inclined surface, in consequence of which the surface and the mass are forced in opposite directions. This idea would be complete and the resulting phenomena simple and reducible to well known formulæ if the mass acting on the surface were a solid, but in the present case this is far from being so, as the mass is an almost perfect fluid, and the resulting phenomena are varied and complicated accordingly. The particles of air coming in contact with the surface are deflected as a solid mass would be, but in being driven from their course they are forced against other exterior particles, which while deflecting the course of the first particles are themselves disturbed.

“The questions presented by these considerations are: first, what is the nature of the movements of the particles due to these deflections and disturbances; second, what form of surface is best suited for producing the original deflection, and then meeting the new conditions arising from the disturbance in the surrounding air; and, third, what is the mechanical effect of the particles thus disturbed or thrown into motion. In the study of the first two questions, observation of the movements of a fluid is the safest guide. For this observation we may use a gas or a liquid, as both, being fluid, show the same phenomena and reveal the same laws; the only important difference being, that owing to the limited viscosity of a gas, its movements are more perfect and rapid than those of a liquid, whose viscosity hinders the perfectly free movement of the particles. But owing to the ease with which the experiments may be performed and the movements detected, the use of a liquid offers many advantages. For the purpose of study, I used

a broad sheet of water (preferably distilled, as a slight surface tension in ordinary water prevents certain delicate movements being revealed) which by suitable means can be set in motion, giving a perfectly even stream whose velocity is regulated at will, to make manifest the various phenomena.

“The first phenomena to be noted is when the water is at rest. If a tube be placed close to and parallel with the surface, and a quick blast of air is forced through it, two opposite whirls are formed, which advance over the surface as they increase in size, as in Figure 44. These are

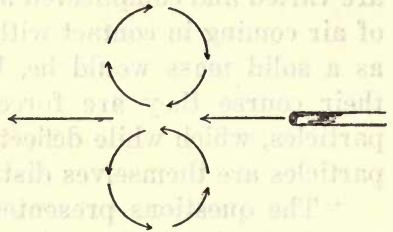

FIGURE 44

made manifest by very light chaff sprinkled on the surface. In passing, I may note the difference between the action in water and in air. If a similar puff be made in air, by which vortex rings are produced, we notice that the elements of rotation forming a section of the ring are much smaller and more rapid than these rotations shown in water.

“But if a small flat surface *b*, Figure 45, be placed in the water and a steady jet forced through the tube *a*, two whirls are produced and maintained in front of the surface and two in the rear, while some of the rotating elements of those in the rear conflict and then blend to form a stream *c*.

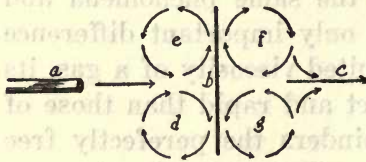

FIGURE 45

“If the surface be placed at a small angle to the

jet, as in Figure 46, there is a breaking up of the system of rotations, but that corresponding to *d*, Figure 45, is developed and predominates. The impulse sent from the jet over the surface simply reveals the tendency to rotation when a stream impinges upon a surface. This tendency may or may not appear as an actual rotation according to circumstances, as the following will show. If a plane be placed in shallow water, its lower edge resting on the bottom, and moved

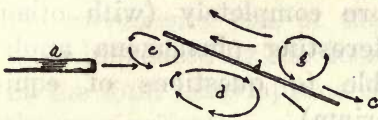

FIGURE 46

gently in a direction perpendicular to its surface, then stopped; four rotations, corresponding to those of Figure 45, will appear, which move away in the direction *c c c c*, Figure 47. Again

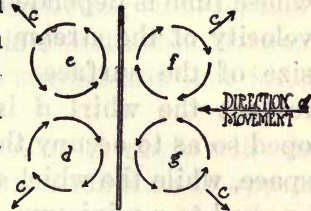

FIGURE 47

if this plane be moved at an angle (about 45° seems best) as in Figure 48, and then stopped, the two rotations corresponding to *e* and *g*, Figures 45 and 47, will have disappeared and those corresponding to *f* and *d* will remain. It will be noted that these two have the same direction of rotation, while at the same time there is an incipient rotation in the water

as indicated by the small arrows *h*.

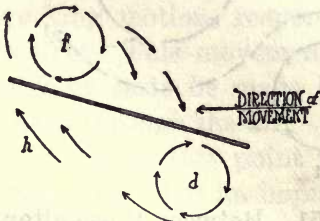

FIGURE 48

“If at the very instant of stoppage the plane be quickly lifted from the water, the two rotations, *f* and *d*, will immediately blend and form themselves into one large

rotation, as is very clearly shown in Figure 49.

“From these experiments we see that a surface moving a fluid has a tendency to build up rotations, which under certain circumstances will blend into one, this being retrograde as shown in the last experiment, with the ascending element of rotation in advance of the surface. Further tests in moving water will reveal this more completely (with other interesting phenomena applicable to questions of equilibrium).

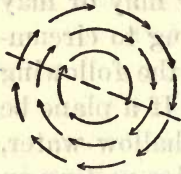

FIGURE 49

“A surface *a*, Figure 50, is placed in a gentle stream *s* and immediately whirls will be noted in its rear, which on examination are seen to have a synchronous movement whose time is dependent on the velocity of the stream and the size of the surface. At one instant the whirl *d* is developed so as to occupy the whole space, while the whirl *e* is suppressed to a minimum. At this instant *d* moves in the direction *c*, while *e* develops, and another *d* exists as a

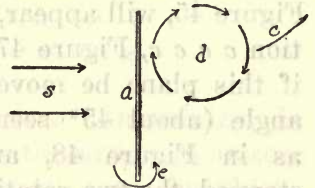

FIGURE 50

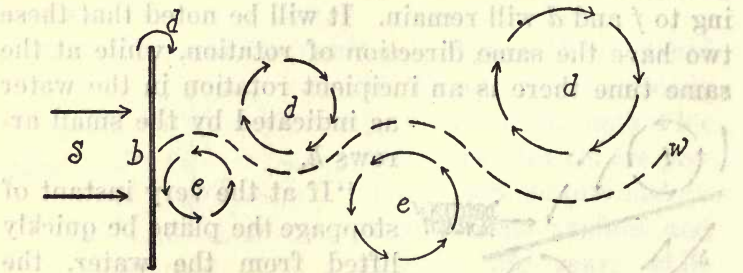

FIGURE 51

miniature, as shown in Figure 51. Between these alternately escaping whirls there is a wave line, shown at

w, Figure 51, suggestive of the waving of a flag (the latter phenomenon being definitely due to the existence of such whirls); while at the same time, on the surface of the water in front of the plane delicate lines appear, which swing from side to side with the movements of the whirls in the rear. These lines are not ordinary wave lines, but sharp distinct lines of division between the movements, etc., of the fluid immediately related to or influenced by the deflecting surface, and the rest of the fluid mass approaching it, while the whirls in the rear indicate a similar division. These and other

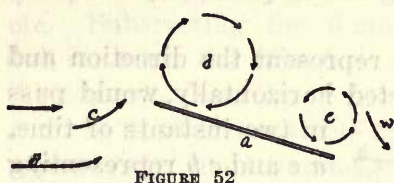

FIGURE 52

phenomena indicate that, though there is a general movement in the fluid produced by a deflecting surface, there is a distinction between

that immediately related to the surface and that which is further removed.

“When the plane *a* is placed at an angle with the stream, as in Figure 52, the whirls continue to appear and alternately escape, *d* being more pronounced and powerful than *e*, while the stream at *c* rises in front of the plane and that at *w* descends. If the planes in these two tests are pivoted so as to be capable of a free movement, they take up a slight swinging or rocking motion, responsive to the movements of the whirls. This movement is much more pronounced if similar tests be made by moving corresponding surfaces through the air.

“Up to this point we have seen enough to indicate: first, that an impulse in a fluid tends to set up a series of rotations; and second, that a surface inclined to the impulse tends to suppress some of these rota-

tions while augmenting others, and finally to blend all into one. An analysis of these points must be omitted for brevity's sake. However, this element of rotation will appear again in speaking of the proper form and adjustment of surfaces.

“In determining the proper form of surface, the first suggestions are derived from the conception of a body projected in a straight line but deflected from its course by a constant force acting at right angles—as a mass projected horizontally and pulled down by gravity, thus describing a semi-parabola, according to well known laws.

“In Figure 53 let $a b$ represent the direction and distance a mass m , projected horizontally, would pass in two instants of time, $a e$ and $e b$ representing equal times. But under the action of gravity, the mass will describe the curve $a h d$. Drop the perpendicular $e h$

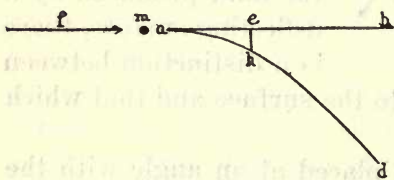

FIGURE 53

to the curve; then the point h will mark its position at the end of the first instant, while d is its position at the end of the second. Then, as the work performed by gravity during the two periods of time is equal, that performed on $a h$ equals that on $h d$. But as the converse of this is true, if $a h d$ be a curve and a mass m is driven along its surface by a force f , parallel with $a b$, its reaction against the curve will exert pressures perpendicular to $a b$, which are equal on the two branches $a h$ and $h d$. While this idea affords an elementary conception, we find it does not fully satisfy the requirements of a moving fluid mass, and applies only to those particles in contact with the

surface. Hence we must look to some other analysis for a full conception.*

“In a study of the parabola, we find it has an intimate relation to the tangent at its vertex and the circumference of an osculatory circle whose center is at its focus, as shown in Figure 54. In this ab is the directrix, lm the tangent, and c the focus. In the evolution of the parabola, $fg = cg, kh = ch$, etc. Subtracting the distance al , between the directrix and the tangent, from fg, kh , etc., and the radii of the circle from cg, ch , etc., the differences are

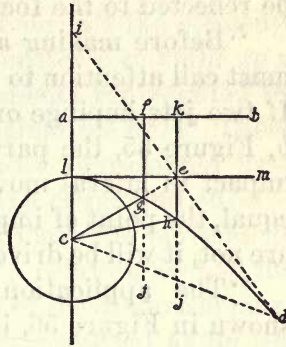

FIGURE 54

equal, that is, the perpendicular distances from the circle are equal to those from the tangent. A further study of this development shows that all these lines, fg, cg , etc., form equal angles with the tangents to the

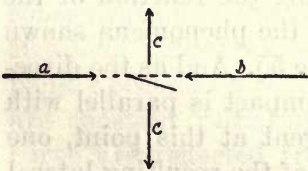

FIGURE 55

curve at the points of intersection. From these two considerations we see that equal impulses from the tangent lm and the circumference of the circle will meet at the curve, producing resultants in the direction of the tangents at these points. And finally,

* To students who are able to follow them, the reasoning and the analyses from this point to the end of Professor Montgomery's paper are commended as worthy of the profoundest attention and consideration. The time is certain to come when the clear logic and brilliancy of these remarkable investigations and conclusions, taken in conjunction with their wonderful experimental verification in California in 1905 (see Page 138), will rank their author not merely with present-day aviators, but with the world's greatest physicists and mathematicians.

according to a well known property of the curve, all impulses from the center will be reflected from a parabolic surface in parallel lines (as $j j$), and, vice versa, all parallel impulses (as $j j$) reaching the surface will be reflected to the focus c .

“Before making application of these properties, I must call attention to a phenomenon of jets or streams. If two jets impinge on one another, as shown at a and b , Figure 55, the particles will escape at the point of impact in lateral movements $c c$. If the streams are equal, the point of impact will remain fixed; but if they are not, it will be driven towards the weaker jet.

“The application of these various elements is shown in Figure 56, in which $a h d$ is a parabolic surface placed in a fluid and s is a jet fixed in the line $a b$. When an impulse from this jet impinges on the surface it will develop pressures against the surface as shown in Figure 53, but as it continually moves away from the tangent line $a b$ it produces pressures on the adjacent fluid, as shown by the arrow f . And, further, as it moves along the curve, meeting the reaction of the fluid as shown at o , it produces the phenomena shown

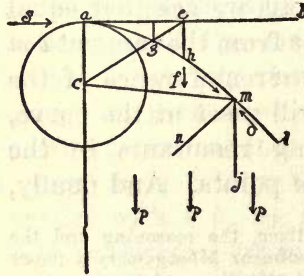

FIGURE 56

in Figure 55. And as the direction of impact is parallel with the tangent at this point, one element of the resulting lateral pressure, is against and normal to the curve; while the opposite element is towards the fluid mass, and in the direction the normal $m n$. But an analysis of the normal shows it is composed of two equal elements, one, $m c$, pointing to the center c , and the other, $m j$, perpendicular to the

line $a b$. As this impact of the stream and reaction of the disturbed fluid takes place along the entire surface, producing a normal pressure at every point, there is a diversity of pressures in the fluid mass, which diversity is harmonized by the analysis given; all the elements represented by $m c$ going to the center c to build up a center of pressure, while the elements represented by $m j$ develop parallel pressures against the fluid. These pressures being parallel with those represented by f combine with the latter to produce a compound effect—first, they impart to the adjacent mass the movements $p p p$, and this movement sets up a rotation around the center c ; and, second, the *reaction* of the disturbed mass against the impulses f and j is transmitted as an impulse back to the surface, and is reflected to the center c , thus increasing the compression at this point. As might be surmised, the reflected impulses to the center c would have a tendency to drive it out of position, but the impulse s (as an element building up this rotation), is an opposing force, keeping it in place. Owing to the concentration of the various lines of force, and the restraining influences, and because of the rotation, the point c becomes a center of pressure from which there are constant radiating impulses, which reaching the curve are reflected from its surface in lines parallel with the first impulses. But, as a radiating center sends out equal impulses in equal angles, there is a new distribution of pressure on the curve because of these radiated impulses. An inspection of Figure 54 will show that the angle $i c e = e c d$. Hence, the impulses falling on $l g$ equal those falling on $g d$. The point g then becomes the center of pressure on the curve due to the radiated impulses from c , while h is that due to the parallel impulses from the first reac-

tions, *f*, Figure 56, of the moving particles against the curve. But between the points *g* and *h* there should be another central point of pressures due to the elements *m n*. The reason for this will appear in the following consideration. Suppose we have a number of elastic particles in a straight line, and a constant force acts on the first; each particle successively will react against the force, thereby building up a gradually increasing pressure, till the last is set in motion. And owing to these successive increments of reaction against the force, the pressure will be least at the last particle, gradually increasing in an arithmetical progression to the first. From this it would appear, that the elements *m n* should increase in intensity from *d* to *a*, thereby causing the central point of pressure, from these elements, to be located near the front edge (approximately one-third the total distance).

“Another conclusion from this principle of successive reactions is, the greater the number of particles in series the more intense should be the pressure, and as a general result of this the intensity of pressure on a surface should increase with its dimensions. And in the special application to wing surface in gliding movement (where the escape at the ends is cut off by the length of the wings), the intensity should be proportional to the width.*

“This principle seems to receive confirmation in the following experiment. If a plane be placed in a constant stream, perpendicular to its surface, the elevation of the water will increase from its edges to its center. But if the plane be doubled in width, the eleva-

* This is undoubtedly the law underlying the well-recognized decrease in proportion of area to weight, as the creatures become larger, in nature's flying machines.—[ED.]

tion at the center will be much greater than in the first instance, and as the elevation may be taken as an indication of the pressure, the conclusion is obvious.

“In an experiment illustrated in Figure 57 some of the phenomena mentioned are shown. In this ab and ad are two surfaces, corresponding to ahd , Figure 56, placed in shallow water, and j is a jet of air near and parallel with the surface. The jet sets up a stream on the surface, which is cut by the point a and flows along the curves as shown at h and i . In flowing along, these streams, h and i , set up movements, as shown by the small arrows, which pass into rotations around the points c f . Particles of chaff on the surface reveal these movements, while pins fixed at the foci of the parabolic curves, and extending above the surface,

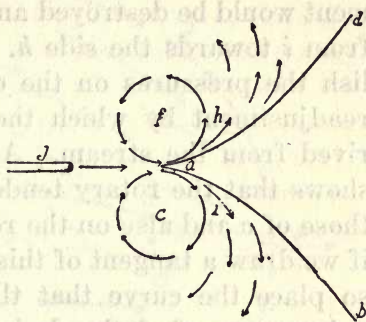

FIGURE 57

assist in observation.

“If the planes shown in the last experiment are placed in a stream s , Figure 58, the same development of pressures takes place but the complete rotations are hidden because of the general movement, though they substantially exist in a general wave line.

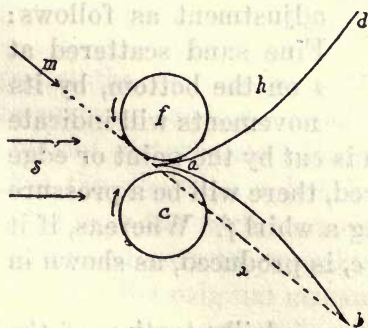

FIGURE 58

In this system, there are three general elements of action and reaction; first and second are

h and *i*, which mutually hold one another in balance, and act reciprocally in building up and maintaining the various movements and pressures; and the third, these combined reacting on the exterior stream, accord to the statements in the discussion of Figures 50 and 51. Should one of the elements *h*, for instance, be removed by taking away the curve *a d*, the development would be destroyed and there would be an escape from *i* towards the side *h*. And in order to re-establish the pressures on the curve *a b* there must be a readjustment by which the necessary element is derived from the stream. An inspection of the figures shows that the rotary tendencies around *f* press upon those of *c* and also on the rear of the curve *a b*. Then if we draw a tangent of this circle *f* to the point *b*, and so place the curve that the stream comes from the point *m*, we find the desired adjustment, though the pressures on the curve are derived from modifications of the ideal movements.

“On placing the curve *a b* so that the stream approaches in the direction *m b*, Figure 59, we test the adjustment as follows:

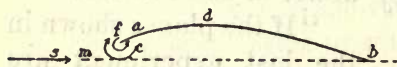

FIGURE 59

adjustment as follows:
Fine sand scattered at *x* on the bottom, by its movements will indicate

that the approaching stream is *cut* by the point or edge *a*. But if this point be lowered, there will be a pressure on the upper surface, causing a whirl *f*. Whereas, if it be elevated a reverse whirl, *c*, is produced, as shown in the illustration.

“In Figure 60 we have a good illustration of the complete system of movements in this adjustment. The stream *s* gradually rises and is cut by the edge *b*; the portion flowing below the curve slows up and is

more or less ill-defined in its movement. But, pressing against the curve, it causes the water level to rise and passes out as shown by the arrows *g*. Near the surface of the curve there are jerky movements as shown at *c c c*. Above the surface, the current sweeps around *a*, leaving a deep depression, but turns and descends

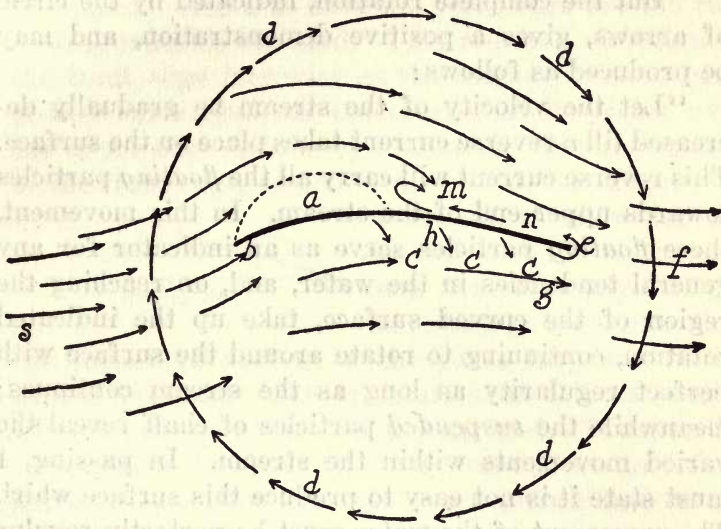

FIGURE 60

against the rear upper surface, and, conflicting with the currents coming around the rear point *e*, produces a violent disturbance. Some of the current around *e* takes the direction *n* but terminates in the whirl *m*. In the rear the various movements combine and form a displaced current, traveling in the direction *f*, parallel with the original stream. Owing to the pressure exerted by the descending current on the upper rear surface, the effectiveness of that on the under surface is reduced. An inspection shows the height of water from *e* to *h* to be only a little more than that from *e*

to m , while, owing to the deep depression at a and the elevation from b to h , the greatest effective pressure is located in this region. The general movement of the current forms a wave line, this being a resultant of rotary movements and the rectilinear movement of the stream.

“But the complete rotation, indicated by the circle of arrows, gives a positive demonstration, and may be produced as follows:

“Let the velocity of the stream be gradually decreased till a reverse current takes place on the surface. This reverse current will carry all the *floating* particles towards upper end of the stream. In this movement, these *floating* particles serve as an indicator for any general tendencies in the water, and, on reaching the region of the curved surface, take up the indicated rotation, continuing to rotate around the surface with perfect regularity as long as the stream continues; meanwhile the *suspended* particles of chaff reveal the varied movements within the stream. In passing, I must state it is not easy to produce this surface whirl. The movement of the water must be perfectly regular and under perfect control as to velocity. There must be no irregularities in the channel and the water must be as free as possible from viscosity and any surface film, rain water being the only kind I have succeeded with.

“While this seems to be the ideal of the form and position of a surface for receiving fluid impulses and developing the proper reactions, there are certain modifications to be introduced in practice as will appear from the following:

“It will be noticed in these demonstrations that the free movements of the water are referred to the

front and rear edges, there being no escape around the edges at the bottom or the surface of the stream. But if we take a curved surface narrow enough to be submerged, part of the fluid will escape over the upper edge, and the reactions necessary to produce the rising current in advance of the plane are only partially developed. Hence to have the front edge *cut* the current, it must be elevated. This required elevation of the front edge increases as the surface is more completely submerged, as the escape of the water over the upper edge is thereby increased. But if portions of the front edge, as shown at *a b c d*, etc., Figure 61,

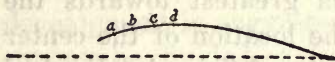

FIGURE 61

be cut off, to allow for the deficiency in the rising current, the front edge of the curve may be lowered so that the remaining portion of the curve may assume its proper position. The application of this is readily apparent in the wings of a soaring bird. Towards the center, near the body, the curvature is at its fullest development. But near the outer extremities, where the air partially escapes around the ends, the sharp front curvature disappears, the wing surface becoming less curved and more narrow—a fact that has been noted by many investigators.

“Here I must call attention to an important element. In discussing Figures 54, 55, and 56 I pointed out the positions of the centers of pressures, and in Figure 62 we find the application. Let *e b* be the horizontal, and also the direction of movement of the curve *a b*, in its proper position. From the construction, we see that the center of pressures due to the *direct* reaction of the moving particles is at *f* while that due to the pressure emanating from the center *c* is at *g*. If we draw a

“Before leaving this part of the subject I must call attention to two important elements—first, from a study of Figures 59 and 60 it is seen that it is the *reaction* within, or under, the curve that causes the ascending current in advance of the curve, hence, should there be an object within this space, causing a resistance to the fluid movement, it by reaction will further increase this rising current, and as this is increased the front edge may be lowered still more, and thereby the element of pressure on the forward surface augmented, which will partially compensate for the resistance due to the object; second, in the use of two surfaces, one in advance of the other, the line of development is suggested in Figure 59. Suppose this surface be divided at d and the sections moved apart, the intervening space gives to each part an individuality, but their mutual reactions give them an interrelation. Hence in the practical use of such surfaces the curvature of that forward should be more pronounced, and its inclination greater than that in the rear. However, without a proper understanding how to determine these elements dangerous mistakes might be made.*

“Having pointed out what seem to be the fundamental principles in the formation and adjustment of a gliding or soaring surface, I now place the whole idea in a single expression, as a stepping stone to the consideration of mechanical principles relative to the problem of the energy involved.

* Definite laws have been found to exist in accordance with which the relation between the focal length and the chord length of the parabola varies in accordance with the size of the machine and with the sustentation per unit of area. At the present time the writer is not at liberty to make public this data, but hopes to be in a position to do so in the near future.

“Conceive a long narrow surface, such as a bird’s wings in a horizontal position, having no formed motion, but being pulled down by gravity. In descending through the air this surface sets up two whirls around its edges, and we readily perceive that the work of gravity in pulling the surface down is divided between the descending surface and the whirls escaping around its edges. Now, suppose the surface be given a horizontal movement of such velocity that the complete system of movements shown in Figure 60 is built up; then these opposite whirls being blended into one rotation, having its ascending elements in advance of the surface, the work of gravity impressed upon the air comes back to the surface, giving it an upward impulse.

“Now let us inquire what is the significance of this operation, relative to the question of energy. This point is well worthy of the sincerest inquiry, for who has not been enchanted and mystified by the beautiful movement of the soaring bird? And who has not asked the question, over and over again, whence does it derive the power to perform such feats, so much at variance with other phenomena and our ideas of motion?

“Having passed through the ordeal of these perplexing questions, and been forced to their solution by going back to the infancy of mechanics, I am compelled to state that some of the elementary questions, as they appear in our text books, have not been developed as completely as they should have been, and thus the minds of even the best students have been left with some erroneous conclusions, attributable directly to a too restricted investigation.

“In entering into this question let me suggest that we abstract our minds as far as possible from all

knowledge and conclusions on the subject, so as to follow the building up of the demonstrations without prejudicing them by ideas that we possess, or which must in their natural order come later. As may be inferred from the preceding we shall simply go back to the most elementary principles, and expand them, emphasizing such points as relate to the question."

FORCE AND MOTION

"A force acting upon a movable mass imparts to it a velocity which is a product of the force multiplied by the time of action; $v = ft$.

"The force may be a pure force, as gravity, it may be the pressure of a compressed elastic body, or it may be the impact of a moving mass. Regarding the forces derived from a moving mass it may be stated that when there is a series of impacts, the element of time is composed of the duration of each impact multiplied by the number.

"From a confusion of ideas on this subject erroneous conclusions sometimes arise. A force is simply considered a force in a general way, and must produce so much motion and no more, the element of time and the factors that determine it being entirely lost sight

of. Experiments illustrated in Figure 63 will be instructive on these points. *A* and *B* in this illustration, are two masses fastened to rods and supported by the pivots *f f*. Between them is the spring *c*. In the first experiment, let *A* and *B* be equal. If the compressed spring be released, it will drive the two masses apart, *A* reaching

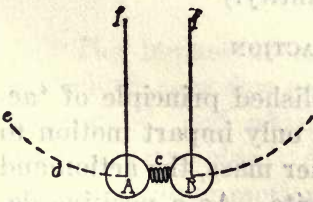

FIGURE 63

the point d , but in a second experiment let B be greater than in the first, A remaining the same; then when the compressed spring is liberated, the mass A is forced to a higher point, e , owing to a greater velocity being developed through the time of action being prolonged by the greater inertia of the larger mass B . A full and clear conception of the formula $v = ft$, and a realization of the fact that the masses operated upon are important elements in determining the time, are necessary to an understanding of the present problem."

MOMENTUM

"When a mass is in motion we have not only the question of velocity, but also that of quantity of motion, or momentum, expressed by the formula $m v$. A unit of force acting for a unit of time on a unit of mass will develop a unit of velocity, and the unit of a mass, multiplied by the unit of velocity, gives a unit of momentum. Then introducing the element of mass into the formula, $v = ft$, we have $m v = ft$. Multiplying both sides of the equation by n units, we have $n m v = n f t$, a general expression for the generation of momentum. (In these expressions, t signifies one unit of time, f one unit of force, v one unit of velocity, m one unit of mass, and n a known quantity.)"

ACTION AND REACTION

"According to a well established principle of 'action and reaction,' a force can only impart motion to a mass by the reaction of another mass, the action and reaction being equal and opposite. As a positive deduction from this it may be stated that if we find a body moving in a given direction there is somewhere an *equal* and *opposite* motion. The first and most

elementary way of expressing this motion is in terms of momentum; and, representing the opposite directions by + and — we have as a general expression,

$$m v = m_1 v_1.$$

Let us now develop this formula in a special line, so as to give a rational explanation to what may appear as an absurdity in some processes which follow.

“In the last formula let $v = v_{11} + v_{111}$; then substituting these and developing, the formula becomes

$\frac{m v_{11} + m v_{111}}{m v_{11} + m v_{111}} = m_1 v_1$. For the purpose of using this formula to illustrate certain points, let us put it into figures.

“Let $m = 1$; $m_1 = 2$; $v_{11} = 1$; $v_{111} = \frac{1}{3}$, then, from the formula, v_1 is found to be $\frac{2}{3}$. We now place these figures in order and leave them for future use.

$$\frac{m v_{11} + m v_{111}}{1 \times 1 + 1 \times \frac{1}{3}} = m_1 v_1$$

$$1 \times 1 + 1 \times \frac{1}{3} = 2 \times \frac{2}{3}$$

$$\text{Momenta} = \frac{1 + \frac{1}{3}}{1 + \frac{1}{3}} = 1\frac{1}{3}$$

IMPACT OF ELASTIC BODIES

“The impact of elastic bodies presents phenomena which very few seem to have studied, still fewer understand, and which many are ready to deny on general principles. And because of certain vague ideas regarding motion and the exchange of momenta there seems to be an inability to grasp the truths derived from some of the mathematical formulæ, or to understand the phenomena of their experimental dem-

onstrations. To have a proper conception of these one must have recourse to a little more profound study than is afforded in the ordinary text-books.

“In the present discussion all that I hope to do is to give a demonstration of the truth of some of the propositions, with general suggestions, as the revolving of the subject in its many phases would be too lengthy.

“In presenting the formulæ of the impact of elastic bodies I shall develop a special case, so as to demonstrate that what appears an absurdity is a rational conclusion in the light of the formula of action-and-reaction just developed. These are general formulæ for the purpose of determining the velocities of two elastic bodies after impact, and cover all possible cases.

“Let A and B represent two elastic bodies, having the respective velocities V and U ; and let v and u represent their velocities after impact.

$$\begin{aligned} \text{Then } (A + B) v &= 2 B U + (A - B) V \\ (A + B) u &= 2 A V - (A - B) U \\ \text{Let } A &= 1, V = 1, B = 2, U = 0 \end{aligned}$$

“Substituting these values in the formulæ, we find, $v = \frac{1}{3}$; $u = \frac{2}{3}$; these being the velocities and directions after impact. Multiplying these velocities by the respective masses gives the respective momenta, that of A being $\frac{1}{3}$, and B , $1\frac{1}{3}$. This latter, to many, is a manifest absurdity; for as the original momentum of A is supposed to be only 1, how can it give $1\frac{1}{3}$?

“Let us analyze the problem, and assume that two equal elastic masses $m = 1$ and $m_1 = 1$, are acted upon by a force f , which imparts a velocity 1 to each, as in Figure 64.

“Let m_1 , now impinge on the elastic mass $M = 2$.

Then, according to the formulæ just presented, m_1 will rebound from M with a velocity $v_{11} = -\frac{1}{3}$. If this be

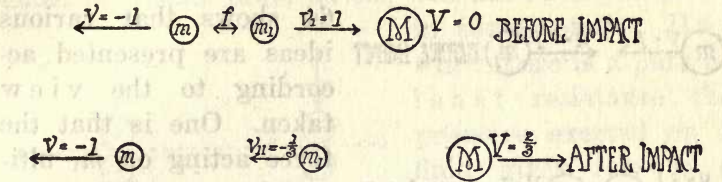

FIGURE 64

so, we have, on one side, two masses having a velocity and momentum in the — direction

$$m v = -1, m_1 v_{11} = -\frac{1}{3}.$$

“Referring now to the formula of action-and-reaction, we see there must be an equal and opposite momentum in the + direction of $1\frac{1}{3}$, and this we find in $M = 2$, with $V = \frac{2}{3}$.”

“Now let us combine these ideas with those presented under the discussion of Figure 63, and we have a universal expression of the phenomena of action-and-reaction. In Figure 63 it was noted that with a given force the resulting motion of momentum was dependent on the masses of the bodies acted upon.

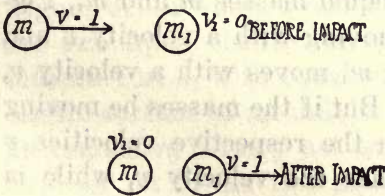

FIGURE 65

But, it is apparent, this is not final, for a given force f , Figure 64, acting on m and m_1 , generates momenta which are a proximate result; but as

m_1 impinges on another mass M the ultimate result of the action of the force is the momentum generated in M . In this case m_1 may be considered a force acting on M , and the momentum generated is measured by

the intensity multiplied by the *time*, and the *time* is determined by the *inertia* of the masses.

“An inspection of the system presented in Figure 64 shows that various ideas are presented according to the view taken. One is that the force acting on m_1 ultimately causes it to move *against* the force, another is that m_1 im-

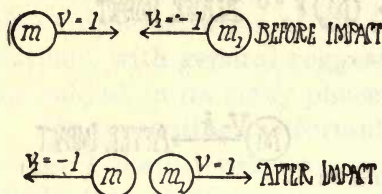

FIGURE 66

presses upon M a momentum equal to its *impact* and *reaction*. Further, while we may for the purpose of drawing special deductions fix our attention on the movement of one or another of the masses, we must bear in mind that each is only *one* of the operating elements in a *system*, and hence must *not* be considered *by itself*, but as an *element* related to the *whole*. Finally, whatever motion any of the elements may have, the algebraic sum of all the movements in the system must be zero.

“In applying the formulæ of the impact of elastic bodies to the case of two equal masses m and m_1 , Figures 65 and 66, if m be moving with a velocity v and m_1 is at rest, after impact m_1 moves with a velocity v , and m is brought to rest. But if the masses be moving against one another, with the respective velocities v and v_1 , after impact m_1 has the velocity v , while m has v_1 .”

IMPACT OF FLUIDS

“The elements of a fluid, being elastic, operate in accordance with the laws just stated, but, their free movements being restrained by the reactions of the

surrounding fluid, their impulses are propagated as compression waves, which in their movements come under the same laws, as the well-known experiments in sound prove. But when there is a path of least resistance the pressure exerted on a fluid gives rise to a stream, which while not being elastic as a mass, owing to its fluid nature, produces the

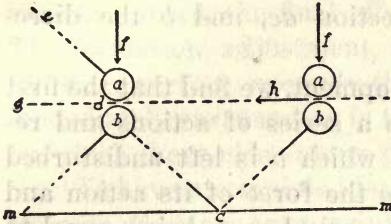

FIGURE 67

same set of actions and reactions as if it were. For the first particles which reach a surface impart to it the momentum of their impact, and then are forced away by the compression arising from those following, and hence exert another element of pressure by their reaction."

APPLICATION

"Having given the elementary principles involved, I now present their application in an ideal case, in Figure 67, in which a and b , in the views to the right, are two equal elastic masses moving horizontally, as indicated at h , with equal velocities, while $m m$ is the elastic surface of an infinite mass. At any instant let an impulsive force f act on a , which will cause it to impinge on b , the two masses exchanging their momenta the latter will take the path $b c$, while a will continue its original direction towards d . But b will rebound from the surface $m m$, and take the direction $c d$, and, coming in contact with a , which has reached the point d , will impart to it the vertical component of its motion, causing it to take the direction $a e$ while b ,

having lost its vertical element of motion, will continue in the direction $d g$. But suppose that at an instant just previous to this impact, another impulse f , act upon a , then the two masses will exchange their momenta, a taking the direction ae , and b the direction $b m$.

“Examining this development, we find that the first force f has simply set up a series of actions and reactions in consequence of which a is left undisturbed while b impresses on $m m$ the force of its action and reaction, these, in this theoretical case, being equal to each other and to the original force f . After the second force has acted on a , and the masses have exchanged their momenta, we find as a result of the action of these two forces $f f$, and the reactions of a and b and $m m$, that there are two elements of force in $m m$, and one in the descending mass b , while a has an ascending velocity theoretically equal to the downward movement imparted by the first impulse f . From this analysis it appears that each downward impulse imparted to a mass may be transmitted to a larger mass, which while absorbing all the original impulse gives back an element of reaction which in turn may be transmitted to the body first acted upon, giving it a movement opposite to that given by the first force; and the large mass then has not only the motion due to the action of the force, but also that due to the reaction of the mass moving from it.

“In these demonstrations we have one element of the actions and reactions taking place in the phenomenon of soaring— a representing the bird, b the air immediately surrounding it, $m m$ the great mass of surrounding air, and $f f$, the impulses of gravity. In this demonstration the impulses are represented as distinct and defined, as are also the masses $a b$ and $m m$,

whereas in the phenomenon of soaring, the action of gravity and the impacts and reactions of the air are continuous, while the reflecting mass of air is ever present in all positions. But because of losses due to various causes, the final effect is far below the ideal. The formation, adjustment, and forward movement of the wing surface, are only the means by which the air immediately surrounding is thrown into the movements by which these elementary processes are perpetuated.

“To have a complete idea of the process of soaring, suppose that an appropriate surface be held in the proper position, relative to the horizontal, as shown in Figure 59, but having no horizontal motion. Under the influence of gravity it will slowly descend. But suppose it receive a gradually-increasing horizontal velocity, then a time will come when the various elements of action and reaction in the air will just balance the impulses of gravity, and the surface will travel in a horizontal direction; then, if this motion be further increased, these actions and reactions over-balancing gravity will cause it to rise, the rapidity of its ascending motion depending on the increase in velocity. It must be noted, that these various changes in the direction of movement, are due to a variation of velocity *alone*, for the surface is supposed to retain the position indicated in Figure 57, and, further, owing to the development indicated in Figure 62, the pressure supporting it tends to maintain its forward movement, or at least to balance the retarding resistances.

“If it be necessary to acquire an increase of velocity, the surface may be slightly inclined and a new impetus obtained, whose measure is not the distance it descends through space, but that through the rising current of air.

“I am aware various objections may be made, based upon the common principles relative to bodies descending and ascending under the influence of gravity. Regarding these possible objections, I shall state, that there are four general cases involved in these principles—first bodies moving in free space; second, an elastic mass let fall; third, the movement of a pendulum; fourth, the movement of a ball over inclined planes.

“A little thought will reveal the fact that these are only special expressions of the great fundamental law of action-and-reaction, or the exchange of momenta, and hence are not to be used as a standard for passing judgment on more complicated and advanced developments of the same basic principles.

“In conclusion, the phenomenon of soaring is the practical operation of a principle pointed out in the discussion under Figure 64—that a force may act on a body under such conditions as to cause the body to move against it. One important and practical instance of the operation of this principle is the tacking of a ship against the wind. Of course, this operation has been frequently analyzed and explained, but underlying *all* we find only the working out of this principle. So it is with the analysis relative to soaring, with this important difference. In the instance of the tacking of a ship, the force is the moving air, while in soaring it is the pure force of gravity. In the first instance, the ship tacks against the wind, but as an essential element in the process must move through a more or less lateral course, while in the second the bird tacks against *gravity*, its horizontal motion through the air being *only* an *element* in the process.

“In our conception of these operations, we should

not fix our attention too closely on the moving objects, but must consider them as only one of the elements in a system of moving bodies.

In each of these cases we have four factors :

First, a force, the *wind*, acting on, second, the *sails*;

Third, the *hull*, acting on, fourth, the *water*.

and

First, a force, *gravity*, acting on, second, the *mass*;

Third, the *wings*, acting on, fourth, the *air*.

“From this study of the movements of fluids, and the special laws involved, we see that gliding, or soaring, flight is not the haphazard dragging of an inclined surface through the air, but a special and unique phenomenon of motion and energy, and holds the same relation to the ordinary phenomena of inclined planes as the operation of the gyroscope does to the simple rotation on a fixed axis. And in the process of soaring, there are not only the form and adjustment of the surface, but also the proper speed and manipulation necessary to produce that special development of movements and energy, *which may be properly termed soaring*.”

“In other words, we must recognize that this is one of the operations in nature based upon a set of *laws* suited to itself; and we must realize that to reach the end to which we aspire we must understand what these laws are and follow them in the designing, construction, and operation of our devices.”

Flattened Tips to wing surfaces, which are the rule with all birds' wings, are not commonly employed in modern aeroplanes, several highly successful machines being notable offenders in this

respect. Fortunately their absence does not render a construction inoperative, but it does set up wholly unnecessary forward resistances, which waste power and impede the progress of the vehicle.*

Angles of Chords of wing sections are the "angle of incidence" of curved surfaces. For the best results these angles should be very flat to the path of movement—much flatter than is common practice, in which the use of inadequate or wrongly curved surfaces is made possible to considerable extents by the employment of excessive angles of incidence. A method of determining proper angles of incidence is explained on Page 186.

WING OUTLINES

There is such great variety in the wing outlines of flying animals as to force the conclusion that within considerable limits the wing plan does not matter, and that various straight, curved, and irregular front and rear edges, and differences in the rounding of wing tips, may be determined more by structural exigencies than by laws of wing action.

Length and Breadth do vary systematically, however, the one rule that is evident in the bird mechanism being the provision of long and narrow wings for fast soaring flight and of shorter and broader wings for slower and flapping flight.

* The points involved in the formation of the ends of wing surfaces are referred to on Page 189, and are also explained in the closing paragraphs of the Montgomery patent specification.

ARRANGEMENTS OF SURFACES

Besides in the forms and outlines of the sustaining surfaces of an aeroplane there is also possible great variety in their number and arrangement.

ADVANCING AND FOLLOWING SURFACES

The use of two or more surfaces, one preceding another, has a number of merits, one of which is the compacting of the supporting areas in a minimum space, and another of which is their utilization to afford fore and aft balance (see Page 221).

SUPERPOSED SURFACES

The use of pluralities of surfaces in vertical series has been already referred to in the discussion of multiplanes and biplanes commencing on Page 168.

STAGGERED SURFACES

Biplanes with the upper surface set ahead of the lower, as in Figure 68, have been built to secure the supposed advantage of locating the two surfaces directly above one another, not in apparent aspect, but within the actual flow of the air streams, which approach with a rising trend as streams indicated by the arrows. A recent biplane of this type,

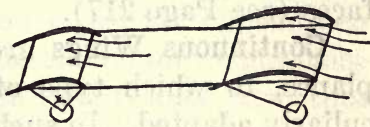

FIGURE 68.—Staggered Biplane. Note that the normal from the curves of the advancing edges meets the currents of upward-flowing air at right angles.

which proved only indifferently successful. is illustrated in Figure 69.

LATERAL PLACINGS

In all successful aeroplanes that have been built the sustaining surfaces extend to much greater distances laterally than they do in any other direction. This limits the variety of practicable combinations.

Separated Wings, with either an open interval, as in Figure 33, or the body of the machine between them, are the commonest construction in monoplanes. The arrangement closely resembles that of the animal mechanism, and, similarly, is probably most effective when the body has a smooth under surface and sides against which the wings abut closely enough to prevent any flow of air through the juncture. Several such constructions are well illustrated in Figures 171, 216, 222, 247, and 249.

For maintaining lateral balance, widely separated movable wing surfaces, or "ailerons", are often used, but these are not main sustaining surfaces (see Page 217).

Continuous Wings are used in nearly all biplanes, to which type of machine they are peculiarly adapted. In such vehicles the upper surface usually is not only continuous but is also free of attachments and obstructions, while the lower surface affords at its center mounting for the engine, accommodation for the operator, etc., as is shown in Figures 23, 172, 189, 190, 208, 224 and 248.

Lateral Curvature is often imparted to wing surfaces for one reason or another—usually in not always discriminating though often effective imitation of the similar aspect of birds' wings. Probably the best form, if other details are so designed as to permit it, that in which the wing ends droop to a pronounced extent, as in the machine illustrated in Figures 225, 226, and 260, which from the front closely resembles the soaring attitude of the gull. Another instance of this wing form was the upper surface of the "June Bug", of the Aerial Experiment Association. In this biplane the lower surface was curved up, so that a very favorable form for structural stiffness was realized in addition to a combination of the merits of the drooped wing with those of the dihedral form. The Wright machines, which appear to be quite straight, are said to fly best when so trussed that there is a slight droop to the wing ends.

Dihedral Angles at the juncture of wing pairs, as in the Langley model illustrated in Figure 70, in which the angle was 135° , have the merit of affording considerable automatic stability in calm air, but in disturbed air have just the opposite effect, the low position of the maximum weight causing the invariable trouble that results from thus placing it—a pendulum-like oscillation of increasing amplitude until the vehicle overturns (see Page 216). Birds often soar and maneuver with their wings in the dihedral position, but their ability instantly to adopt other positions relieves them from the risks that appear when the angle is permanent.

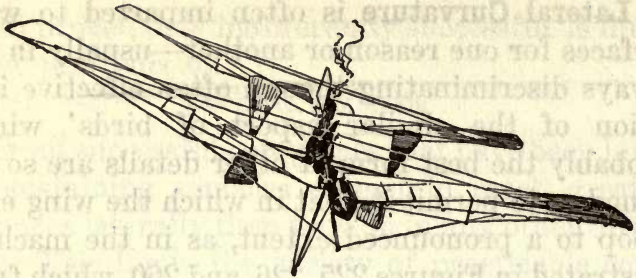

FIGURE 70.—Langley's 25-Pound Double Monoplane, With Wings at Dihedral Angle. This model on May 6, 1896, flew for more than half a mile over the Potomac River, at a speed of about 20 miles an hour. Subsequently, on November 28, 1906, with a similar model weighing about 30 pounds, a three-quarter mile flight at about 30 miles an hour was achieved. This was at the end of a three years' period of experimenting that had for its object the ultimate production of a man-carrying machine. The size of the heavier model was a little over 12 feet from tip to tip, with a length of about 16 feet. The whole power plant, which consisted of a 5-pound boiler and a 26-ounce non-condensing steam engine that developed $1\frac{1}{2}$ horsepower, weighed about 7 pounds. Propulsion was by bevel-gear driven, two-bladed twin screws, rotating in opposite directions behind the forward surfaces at about 1,200 revolutions a minute. The hull was metal sheathed to protect the burner from the wind, and the vessel between the forward surfaces was a float to keep the machine up when it alighted upon the water. In conjunction with the experiments with a man-carrying machine, which terminated with the unsuccessful launching on December 8, 1903, a model similar to the above, but weighing 58 pounds and having 66 square feet of sustaining surface—it being a one-fourth size copy of the large machine—was successfully flown with its 3-horsepower motor.

The Bleriot, Santos Dumont, and Antoinette monoplanes have the wing surfaces dihedrally placed, as is evident in Figures 200, 215, and 220, but in all successful models of these aeroplanes the angle is very slight and its merit much in doubt. The only biplane of which the writer knows in which dihedral wings were used was the not very successful machine of Ferber's, illustrated in Figure 224. Nearly all modern biplanes are built with straight or almost straight wings.

Many soaring birds which in flight set their wings at a drooped or flat angle are observed to hold the extreme tips of their wings pronouncedly upturned—possibly for the balancing effect of

the dihedral position, though this is by no means certain.

VERTICAL SURFACES

Surfaces placed vertically, though not present in any flying animal except the varieties of flying fish, are found quite indispensable in man-made fliers, in which they are made to serve various purposes, including the maintenance of lateral balance, and the effecting of lateral steering (see Pages 216 and 224). Properly placed, they also tend to keep a machine to a desired course regardless of disturbing influences, or headed into gusts of wind that if they continued to come from one side might prove very dangerous. To meet these latter purposes most effectively, the vertical surfaces should be placed to the rear, as in the machine illustrated in Figures 225, 226, 227, and 260, so that the effect of side gusts always must be to swing the machine into the wind.

The use of large vertical surfaces forward is now found only in a few machines, and is probably altogether mistaken design—a conclusion that is especially impressed by the disuse of these surfaces in machines of the Farman and Voisin construction, despite the fact that these were the earliest and most consistent adherents of this design.

Very small vertical surfaces in the forward elevator, as in the case of the semicircular surfaces *jj*, Figure 185, in the Wright machines, and the triangular surface *j*, Figure 229, in the Curtiss machines, are not quite so uncommon as are larger

vertical surfaces in front, but even so their value is decidedly doubtful unless to offset some other defect in design. In the Wright machines these vertical "half moons" are not rigidly fixed but are allowed a few inches of flapping movement, on their diameters as the axis, under the influence of side gusts, presumably with the idea that they thus tend to nose the front of the machine into the wind.

SUSTENSION OF SURFACES

The sustaining capacities of different flat and curved aeroplane surfaces moved through the air at different speeds and at different angles of incidence greatly vary with every new combination of the innumerable possible factors. Determination of the most suitable surfaces and the most advantageous conditions therefore has long been one of the greatest difficulties in the way of aeronautical progress.

EFFECT OF SECTION

As has been previously suggested (see Page 171), there is the greatest imaginable difference in the sustaining effect of different wing sections, flat surfaces being quite inferior to curved, of which the best are more or less exact approximations to parabolic forms. Moreover, with the ideal surfaces there are very curious and not widely understood relations between the lift and drift—between the amount of sustentation afforded by a given speed of movement and the resistance (other than head resistances and skin friction) to the forward move-

ment. With proper design, there is a positive forward inclination to the sustaining force, or lift, which, instead of being normal to the chord of the surface or to its direction of movement, is inclined forward to an extent sufficient, with certain angles and certain curves, wholly to overcome the drift (see Page 190), which, therefore, becomes a phenomenon pertaining only to incorrect surfaces.

EFFECT OF ANGLE

Measured as a proportion of the unit resistance met, when a given surface is opposed flatwise or with its chord at right angles to the air, the values of lift and drift with different surfaces can be tabulated in percentages of this "normal" at different speeds and different angles. Many such tables have been prepared—most successfully by empirical investigations—and from these tables it has been attempted to deduce working formulas by which to solve the variety of practical problems that can arise in given cases. Unfortunately these formulas have been found not to work out correctly in practice to any considerable extent, and many inaccuracies are now known to exist in the most highly regarded tables, such as those of Smeaton and of Lilienthal, the latter of which are widely considered fairly correct—though slightly too high at very small angles.

EFFECT OF SPEED

The many formulas that are more or less widely used in calculating the effect of speed upon the sustentation of different surfaces cannot, in the light

of recent developments in the science and practice of aeronautics, be accepted as correct except within very narrow limits or in a very general way. It can be safely asserted only that the sustentation increases much faster than the speed—possibly with its square.

Particularly interesting in this connection, rather than especially exact, is the glimmer of truth in “Langley’s law”—according to which the power required for propelling an aeroplane surface through the air indefinitely diminishes as the speed increases.

EFFECT OF OUTLINE

With all other conditions equal the sustentation of a surface is subject to variation with change of outline—particularly with difference in width (see Page 184). No adequate explanation of this phenomenon is known other than that contained in the reference cited.

EFFECT OF ADJACENT SURFACES

A given surface moved through the air under given conditions will invariably afford greater support when alone than when adjacent to other surfaces. In a biplane the sustentation of the upper surface is always materially lower than that of the lower surface, especially if the separation of the surfaces is insufficient or the forward speed very low. In the case of following surfaces, as in Figures 97 and 225, at least partial correction for the adjacent disturbance of the air can be had by making

the two surfaces of different form and inclination (see Page 248).

CENTER OF PRESSURE

The center of pressure of a sustaining surface is the lateral axis on which the load is balanced (see Page 181 and Figure 62). With wrong surfaces at wrong angles the center of pressure is a most elusive and variable factor, tending always to uncertain and precarious equilibrium, but with correct surfaces it can be very definitely located and equilibrium maintained by keeping the center of gravity beneath it.

HEAD RESISTANCES

Contrary to the popular notion, the forward resistances encountered in moving any object through the air, no matter what its form, are closely related to the "projected area", being little influenced by "wind-cutting" shapes, thin edges, and other misguided expedients to reduce this resistance. This is experimentally proved in the use of racing automobiles, which at speeds in excess of 100 miles an hour do not measurably differ in their head resistances whether they have flat or elaborately pointed fronts. Projectiles, even, of the common pointed ogival forms do not travel at velocities perceptibly greater than can be obtained under otherwise similar conditions with flat-fronted projectiles. The reason for this seemingly anomalous effect appears to be that in case of a flat or blunt surface there is carried on the front

of the visible structure an invisible cushion of compressed air—varying in its length and form in accordance with the speed, but always automatically created to the exact shapes best calculated to penetrate and part the main body of the atmosphere in most effective manner.

Against flat surfaces moved through the air, the pressure is usually stated to vary with the square of the velocity, a surface one foot square placed at 90°, as in Figure 42, receiving pressures as follows, according to one authority:*

Speed of movement in miles per hour	7	14	21	41	61	82	92
Pressure in pounds per square foot.	.2	.9	1.9	7.5	16.7	30.7	37.9

At twenty-five miles an hour the surface receives a pressure of 3.24 pounds, while when it is inclined to 15° from the direction of the current this pressure, or drift, is reduced to .33 pounds, with a lift of 1.5 pounds, as is made clear in Figure 42. The ratio of lift to thrust greatly increases as the inclination decreases.

* According to a table compiled for the "*Mechanical Engineer's Pocket Book*," the pressures on a square foot of flat surface in different winds are as follows:

MILES PER HOUR	CLASSIFICATION OF WIND	PRESSURE ON SQUARE FOOT
1	Hardly perceptible	.005 Pounds
2	Just perceptible	.02
3	Just perceptible	.044
4	Gentle breeze	.079
5	Gentle breeze	.123
10	Pleasant breeze	.492
15	Pleasant breeze	1.107
20	Brisk gale	1.968
25	Brisk gale	3.075
30	High wind	4.428
35	High wind	6.027
40	Very high wind	7.872
45	Very high wind	9.963
50	Storm	12.300
60	Great storm	17.712
70	Great storm	24.108
80	Hurricane	31.488
100	Hurricane	49.2

Though not especially affected by the form of a surface, head resistance is affected by the extent of surface, being lower per unit of area on small areas than it is on large. This is because the air centrally in front of a large surface must be displaced to a greater extent laterally to pass the surface than is necessary with a small surface. Also, the rear form of an object is of importance, a blunt front and finely tapered rear outline being that calculated to displace and reform the air streams with the expenditure of the least energy.

BALANCING

An aeroplane can only tip over sideways or endways, consequently to maintain it right-side up can require provision only for maintaining lateral and longitudinal equilibrium.

LATERAL BALANCE

It is now well established both from observation of flying animals and in the construction of flying machines that there is a considerable number of ways, all more or less effective, of maintaining the lateral balance of an aeroplane. These methods are, moreover, capable of use both independently and in various combinations.* Furthermore, some of them are of a nature to operate automatically against disturbing forces, whereas others require actuation by controlling means.

* Many birds obviously employ wing warping, tilting and swinging of wing tips, variation of wing areas and angles, and shifting of the weight, in a great variety of combinations.

Vertical Surfaces for maintaining balance are analogous to the similar use of such surfaces in box kites, and act in a most effective and wholly automatic manner—any tilting bringing the side of the vertical surface that is towards the inclination into play as a more or less effective lifting surface (according to the extent of the tilting), with the result that the air pressures promptly force it back to its normal position. As has been previously explained (see Page 209), it seems for a number of excellent reasons inadvisable to place vertical surfaces anywhere but at the rear of a machine.

Dihedral Angles of wings operate similarly to vertical surfaces in maintaining balance, being in their normal position at angles of less than their maximum effectiveness, so that tilting of the vehicle renders the lowered wing more effective and thus automatically corrects itself. The objections to dihedral wings are explained on Page 207.

Wing Warping as a means of steering or balancing, for which it is used in the modern Wright, Bleriot, Montgomery, and other machines, consists of a simple, unsymmetrical twisting of the wing ends by any suitable means so as to transfer the maximum lift from one side of the machine to the other by varying the angles of wing-tip inclination to the line of travel. This method of balancing, which is perhaps the most effective known, was patented in France by D'Esterno, was used by Le Bris, and was first patented in the United States by Mouillard (see Figure 262). Another early

recognition of its merits appears in the *Scientific American Supplement* of June 4, 1881, in which, in an article on aeronautics by Tim Choinski, it is remarked that "When a flying bird wants to go side-wise or turn, it slopes backward to an inclined plane but one wing of that side where it wants to go." Despite the numerous early recognitions of the value of wing warping it did not appear in combination with otherwise successfully operative mechanisms until within comparatively recent years. Its application to the Wright, Bleriot, and Montgomery machines is shown in Figures 185, 197, and 225. An objection to wing warping as it has been commonly applied is that the abrupt inclination of that end of the wing may cause a greater resistance to and consequent slowing of the side of the vehicle which should go the fastest in executing a turn—it being necessary in some aeroplanes to resist this tendency by the simultaneous manipulation of rudder-like vertical surfaces.

Tilting Wing Tips, capable of being thrown up or down into positions less effective than the normal, constitute a means of balancing that was tried by Maxim, and which would seem at least to present the advantage of avoiding the variation in forward resistances referred to in the preceding paragraph.

Hinged Wing Tips, or "ailerons", adjacent to the end or the rear edges of the wing tips proper, or wholly separated from these in the case of several biplanes, are a common and successful

means of maintaining lateral balance without recourse to wing warping. Typical aileron arrangements are clearly shown at *a a a a* in Figures 76, 77, 78, 79, 80, and 81.

Variable Wing Areas, while a common maneuver with many birds, have not yet been provided for in any successful flying machine. A suggested



FIGURE 82.—Sliding Wing Ends.

method of varying wing areas is illustrated in Figure 82. It is evidently analogous to shifting the weight, securing practically the same result.

Shifting Weight as a means of controlling lateral balance was first practically employed by Lilienthal, and subsequently by Pilcher, Chanute, and others. In some of their early experiments the Wrights controlled the wing warping by a movement of the operator's body sidewise in a cradle-like control frame, thus securing a combination of warping with weight shifting (see Page 229). One very serious objection to shifting weight is that it requires extraordinary acrobatic skill to apply this method successfully.

Rocking Wings, pivoted at their point of attachment to the body of the machine, are a very old idea. A notable application of this principle in a successful modern monoplane is found in some recent Antoinette machines, in which the lateral balancing is effected solely by dissimilar rocking

of the entire wings. One of these machines is illustrated in Figures 215 and 216. A most unusual application of rocking wings is that in the Cody biplane (see Figure 202), in which they appear in the forward elevator and serve to control either lateral or longitudinal balance, according to whether they are rocked oppositely or together.

Swinging Wing Tips are another feature of bird mechanism that offers interesting possibilities of application to aeroplanes. This idea was probably first used by Chanute in his patented construction described on Page 462, and illustrated in the form preferred by him as a result of his experiments, in Figure 261, in which the movement of the wing tips

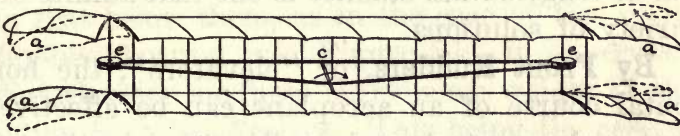

FIGURE 83.—Swinging Wing Ends.

was effected solely by variations in wind pressure. A control-manipulated system of swinging wing tips is suggested in Figure 83. It is an idea of the writer's that if in this the wing tips *a a a a* be given a down curve at their ends, thus approximating a correct wing section in two directions, the result of swinging them to the rear will be to increase the sustentation and the tangential component forward while at the same time reducing head resistance. This would afford an ideal method of steering and close observation is convincing to the effect that it is a method used by many birds.

Plural Wing Tips are plainly existent in the finger-like separated tip feathers of the wings of many soaring birds. The exact utility and manipulation of this type of wing is a mystery still awaiting satisfactory explanation, and perhaps containing the secret of some most advantageous construction.

LONGITUDINAL BALANCE

Longitudinal balancing means are necessary for two purposes—primarily to prevent forward or backward upsetting of the vehicle and secondarily to provide means of steering on up or down slants of air. As in the case of lateral balance, the problem of longitudinal balance is one that admits of a variety of solutions.

By Front Rudders, or “elevators”, the horizontal course of an aeroplane can be effectively kept under control, as is well proved in the case of many modern aeroplanes (see Figures 80, 172, 187, 196, 207, 208, 209, 211, and 229). This elevator placing is more common to biplanes than to monoplanes.

By Rear Rudders practically the same effects can be had as with front rudders, the placing being therefore a matter of choice or of minor consideration. Typical rear-rudder arrangements for controlling fore-and-aft balance are shown at *h h* in Figures 85, 216, 217, 222, and 229, in the latter of which it will be noted that both front and rear elevating surfaces are provided.

Box Tails as longitudinally stabilizing elements

are found highly effective and almost automatic. The most important present examples of this construction are the Farman and Voisin machines (see Figures 81, 207, and 211).

Shifting Weights for maintaining longitudinal balance are even less suitable than for lateral balancing (see Page 218). In the Weiss monoplane an unsuccessful attempt was recently made to apply this principle, the weight sliding on wires and being actuated by a lazy-tongs device.

Plural Carrying Surfaces are commonly provided as important features in the design of many modern aeroplanes. And, indeed, unless definitely made to operate against the air above them as well as that below them, as in the case of the Wright flexible elevator (see Figure 84), it is necessary that elevator surfaces carry some weight if their action is to be effective. This being the case, the proportion of the weight carried on the elevator will be in proportion to the relation of its area to that of its main surfaces. An extreme example of the possibilities in this direction appears in the Montgomery double monoplane (see Figure 225), in which the two main sustaining surfaces, though equal in area, can be variably inclined to each other for the purpose of controlling longitudinal equilibrium (see Page 220).

AUTOMATIC EQUILIBRIUM

In its common significance this term has come to be descriptive of means or devices for correcting an aeroplane's deviations from its normal level

automatically, independent of the attention of the operator. In the majority of projects for its application it is designed to effect only the lateral control—the fore-and-aft control remaining in the hands of the operator as a necessary means of governing descent and ascent.

Arrangement of Surfaces is probably the simplest as well as the most effective means of maintaining lateral balance automatically, as is explained on Page 216, where the effect of vertical surfaces is set forth in detail.

Electrical Devices for securing equilibrium are of a class that automatically correct rather than maintain balance of a machine, and even in their simplest forms are of a complication requiring that hand control be always ready to supplement their action if disaster is not to be deliberately courted. One proposal for an electrical balancing device involves primarily a bent glass tube in which a small quantity of mercury makes and breaks different contacts as the vehicle tilts in different directions. Through these contacts power is applied to the devices that must be manipulated to rectify the equilibrium.

The Gyroscope, because of its peculiar property of resisting forces that tend to shift its plane of rotation, can be so mounted as to remain in a given position irrespective of the movements of its surroundings. In this way a secondary control can be maintained over stabilizing surfaces by the automatic distribution of power for their manipulation. Another way of utilizing the gyroscope is by

making it comparatively heavy and mounting it solidly on a vertical axis. The most impractical feature of this plan—the weight involved—it is proposed to escape by utilizing as gyroscopes parts of the machine that are required in some form in any case, as the flywheels of engines, etc.

Compressed Air, or “fluid pressure”, has been planned for as a means of transmitting balancing manipulations to aileron and elevator surfaces in a patent issued to the Wright brothers in England. In this system, the initial control is effected by the variation of the air pressures on specially provided vanes, or by the swinging of a pendulum.

The Pendulum, preferably swung in a reservoir of oil or other liquid to suppress violent oscillations, has been often suggested as a possible means to automatic stability, but attempted applications have met with no more success than has attended efforts to make practical use of other systems of automatic balancing.

STEERING

The steering of modern aeroplanes is a problem that presents so few difficulties that it has been more or less successfully solved in a considerable variety of constructions, all of which, however, are subject to certain effects and conditions that must be reckoned with by the experimenter.

EFFECTS OF BALANCING

In balancing an aeroplane laterally by the means at the present time most preferred, there is

in most constructions a pronounced steering as well as the balancing effect. Thus in wing warping systems the manipulation of the wing ends is a most effective means of steering and in several machines is definitely so used. In such steering, however, it may be necessary to counteract the lag of the most inclined tip (see Page 217) either by the side resistance of a large fin or by the manipulation of a smaller rudder.

VERTICAL RUDDERS

Vertical rudders, in the proper significance of the term, are rudders used for *lateral*, or *horizontal*, steering, wherefore they must be placed *vertically*. This fact, and a considerable inconsistency in different writers' use of the term, has given rise to no small amount of confusion, which can be dispelled only by more general agreement as to what terms are to mean. Perhaps the easiest escape from the difficulty is to be found in the English substitution of "elevator" for horizontal rudder, leaving the "vertical rudder", placed vertically for steering on a horizontal plane, to be known simply as *the* rudder.

Pivoted Rudders, as shown at *i*, Figures 85, 198, 209, 216, 224, and 229, and in Figure 195, are the common form, though perhaps not the most meritorious.

Flexible Rudders, of the type illustrated in Figure 84, which is taken from the drawings of a patent issued to the Wright brothers, have the merit that they always present curved, instead of

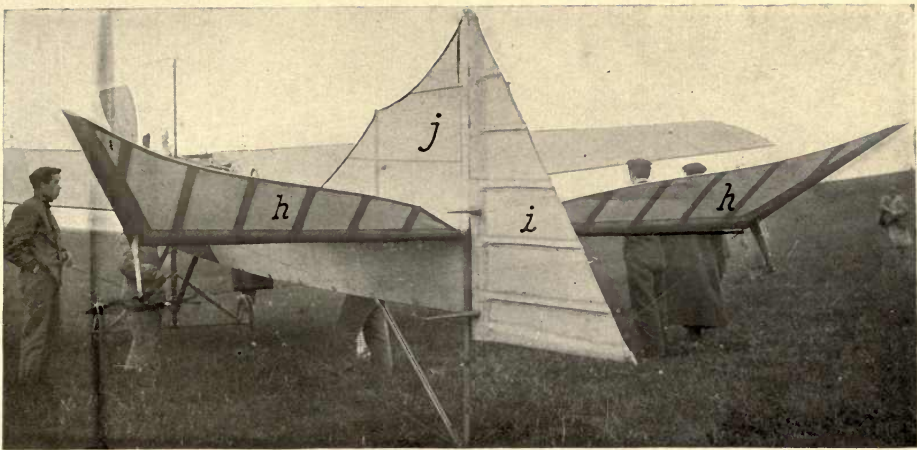

FIGURE 85.—Rear Controls of Antoinette Monoplane. In this *hh* are horizontally-pivoted surfaces for steering up or down; *l* is a vertically pivoted surface for steering sidewise; and *j* is a vertical fin used for its stabilizing effect.

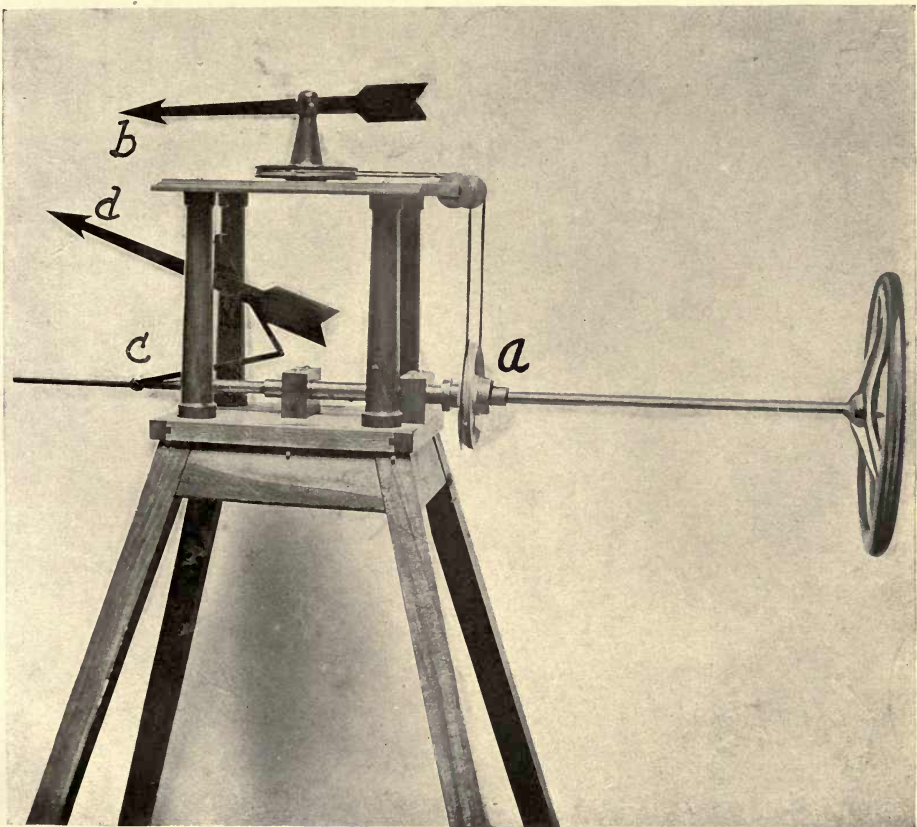

FIGURE 86.—Double Control from Single Wheel. As is very apparent from the system shown in this illustration, two distinct movements can be readily produced by manipulation of a single wheel. For example, the cords passing around the pulley at *a* can be extended to operate wing tips, instead of the vane *b*, when the wheel is revolved, while the link *c* can as well be connected to a vertical rudder as to the arrow *d*.

the less effective flat surfaces, to the air they work against. Obviously this principle of construc-

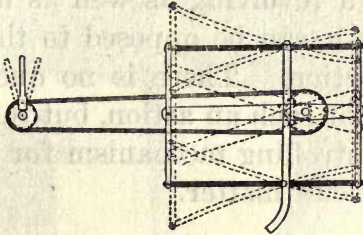

FIGURE 84.—Wright Flexible Elevator or Rudder. When the hand lever is moved into either of the positions shown by the dotted lines the steering surfaces are correspondingly sprung into curved form, presenting approximately correct surfaces to the air above or below them, as the case may be. This springing is due to the pivotal points of the surfaces being not in line with the pivot of the actuating bar between them.

tion is applicable to either vertical or horizontal rudders.

HORIZONTAL RUDDERS

Horizontal rudders, or elevators, usually control not only the vertical steering but also serve to maintain the longitudinal equilibrium. Consequently they serve a secondary function as sustaining surfaces, for which reason it has been already necessary to accord them fairly exhaustive consideration (see Page 220).

TWISTING RUDDERS

Rudders of the type illustrated at *h* in Figure 222 are in a class by themselves. It has been explained (see Page 161) that flying fish are the only ones of nature's flyers normally provided with vertical surfaces, but this statement perhaps disregards the fact that most birds, by twisting movements of their tails, are able to use these as vertical

rudders. In the R. E. P. rudder just referred to it is sought to imitate this action by providing a rudder with a revolving as well as flexing movement so that it can be opposed to the air in any possible direction. There is no question of the effectiveness of such an action, but the problem of a suitable controlling mechanism for it is another and more difficult matter.

CONTROLLING MEANS

The number and complexity of controlling movements involved in the operation and piloting of an aeroplane have long constituted one of the greatest bars to progress in this field of engineering, and still present some of the most difficult of its unsolved problems.

Man being a creature possessed of only two feet and two hands, and flight ordinarily requiring—as displayed by the birds—a variety of manipulations delicate and vigorous, quick and slow, simple and complicated, which man can scarcely hope to imitate, the difficulty of producing them in unfailingly effective coördination must be apparent.

For there are lateral and longitudinal balance to be maintained, vertical and horizontal steering to be effected, a motor to regulate and adjust, instruments and devices to be watched, and the special conditions of starting and landing to be encountered—from all of which it might appear that the average aviator must at least find sufficient to occupy his attention if none of these functions are performed automatically.

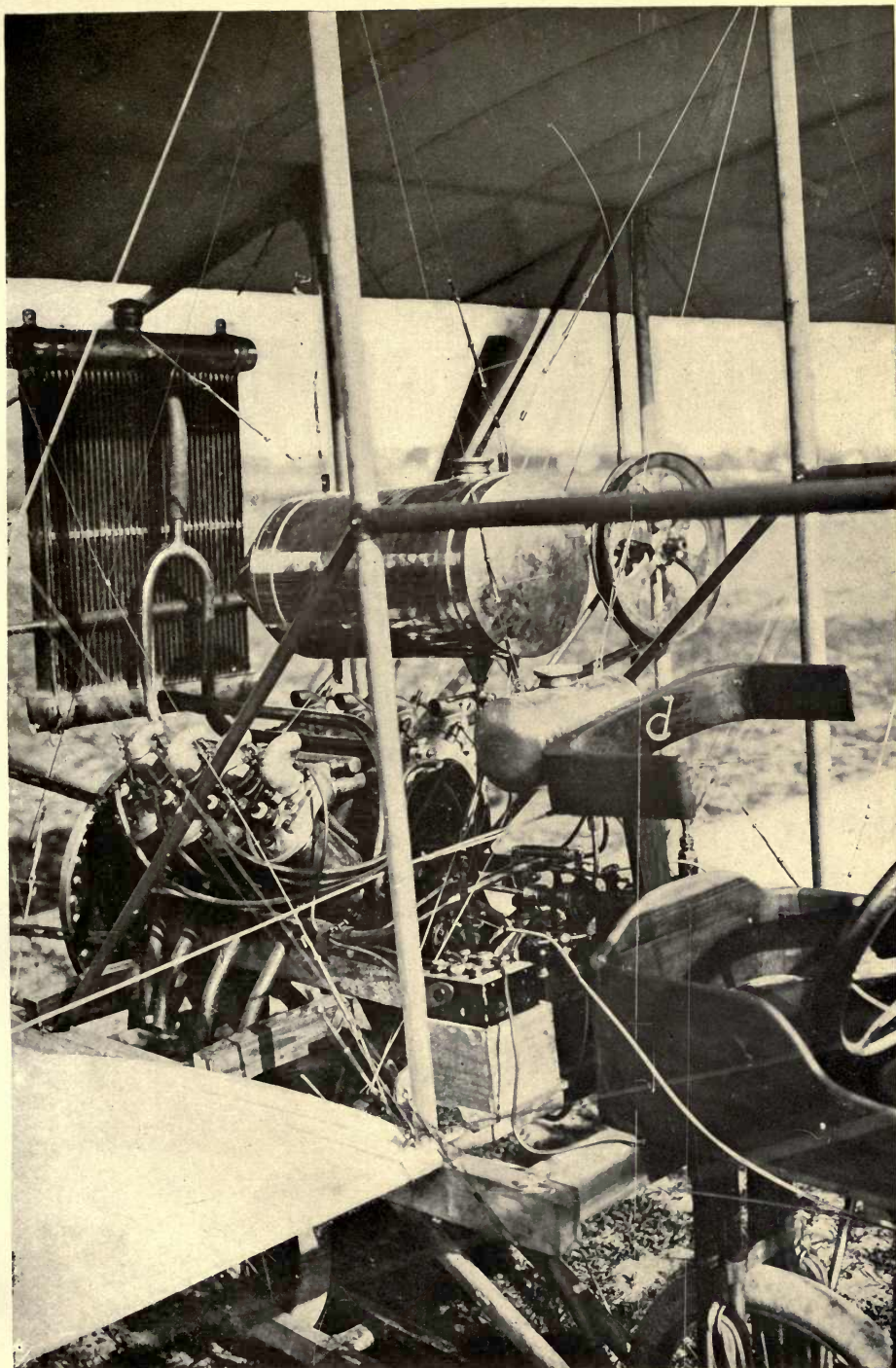

FIGURE 87.—Shoulder-Fork Control. This is a characteristic example of the means of control found successful in the Curtiss, Santos Dumont, and other machines. The fork *d* engages the shoulders of the operator and is so connected that its lateral swing acts upon the balancing mechanisms of the biplane—by the natural swing of the operator's body.

But problems do not exist without roads to their solution, and already in man's advancing mastery of the air much progress has been made in the devising of simple and effective controlling systems, while more simple and more effective systems are quite in prospect.

COMPOUND MOVEMENTS

One of the most effective methods of control is the combination of two or more movements in a device manipulated by a single hand. A characteristic example is given in Figure 86, which is substantially that employed in the Voisin and Curtiss machines (see Figures 202 and 228). Another example is the lever that controls the wing warping and the vertical rudder in the Wright machines (see Figures 185 and 190).

PLURAL OPERATORS

A plurality of operators in steam and sailing vessel navigation is the rule in all but the smallest craft, larger ships being not capable of management by a single individual. In the largest steamships the pilot, upon whom devolves the steering and the general control of the vessel, has no direct means of causing it to change its speed, stop, or go astern—these maneuvers being solely in the hands of the engineer, with whom the pilot is in communication by signals. Similarly, in locomotive operation, control of the steam pressure and fire falls to the fireman or stoker, while the throttle, brake handles, etc., are left to the engineer or driver.

In flying machines, except in the case of dirigible balloons, the only use of two operators of which the writer knows is ascribed to the Wrights, who are said to have operated their early three-lever machine together.

In further development of flying machines the chief need for two operators would appear to be most required as a means of maintaining the motor and the machine generally in continuously and safely operative condition.

WHEELS

Wheel controls having been found thoroughly satisfactory in years of experience with automobiles and watercraft naturally have found extensive application to flying machines, in which their advantages of compact form with great range of movement prove very valuable. Typical wheel controls are illustrated in Figures 86, 172, 202, 228, 229, and 250.

LEVERS

Lever controls are almost ideally simple and in some circumstances perhaps afford less chance for an operator to become confused, by their quality of obviously indicating their position. Levers are used to the exclusion of wheels by the Wrights, and have been employed with considerable success by the Voisins, Farman, Pelterie, and others (see Figures 185, 190, 248, and 252). Undoubtedly there is much to be said for their positive action and simple and inexpensive construction.



FIGURE 88.—Frame, or "Fuselage," of New Voisin Biplane. The ingenious use of wood, left of larger section at the points of attachment to the cross struts, which set into metal sockets, and the rigid diagonal wire bracing, constitute a peculiarly interesting example of modern high-grade aeroplane construction.

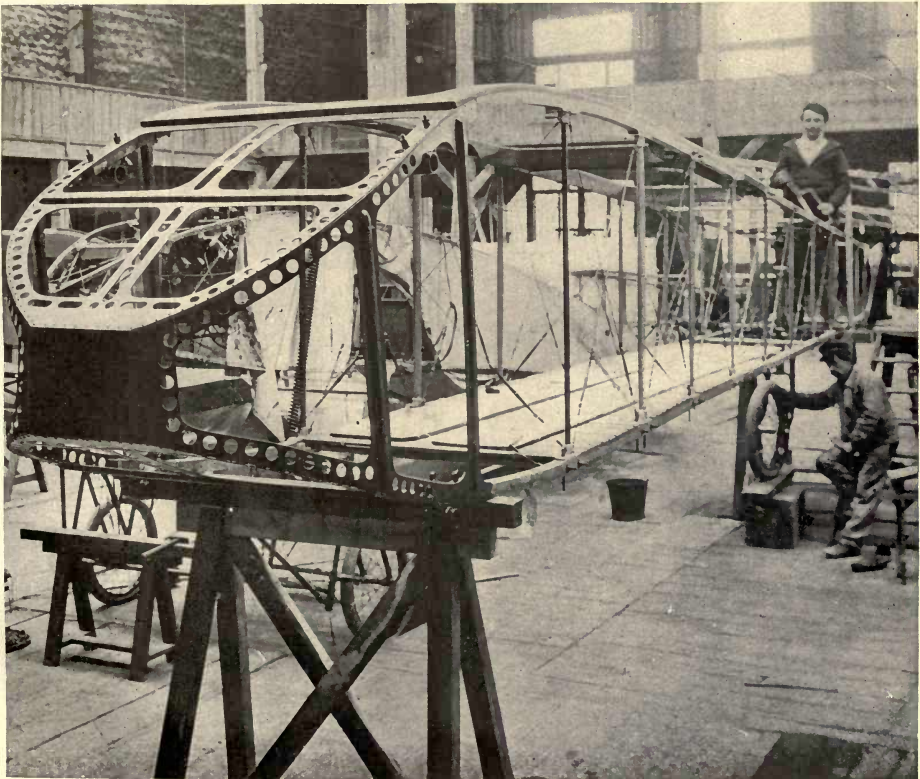

FIGURE 89.—Fuselage of Bolotov Monoplane. In the finished machine this frame is covered over with fabric while the boarded floor comes beneath the operator's seat, motor, etc.

PEDALS

Except for the manipulation of minor devices, pedals have not been extensively favored in aeroplane controlling systems, though Bleriot uses a pedal to control the elevator of his monoplanes (see Figure 197). Other examples of foot or pedal control appear in Figures 225 and 248.

MISCELLANEOUS

Besides wheel, lever, and pedal controls, there are several other devices that have been found of more or less practical utility.

Shoulder Forks, embracing the shoulders of the operator, as at *d*, Figure 87, are used to some extent to control lateral balance by the natural swing of the pilot's body as the machine cants to one side or the other. The most conspicuously successful example of the use of shoulder forks appears in the Aerial Experiment Association's, and the Curtiss machines (see Figures 228 and 229). Practically similar in its effects though not in its construction is Santos-Dumont's ingenious control of the wing warping of his tiny monoplane (see Figure 221) by a lever engaging with a short piece of tubing sewed into the back of his coat.

Body Cradles (see Figure 259) were at first employed by the Wrights as a means of wing-tip control for their early glider, but have since been given up by them and are not known to have been used in any successful flying machine.

FRAMING

The strongest and lightest frame constructions for the wings, bodies and other elements of aeroplane structures have so far followed very closely the general lines suggested in Figures 71, 72, 73, 74, 75, 88, 89, 101, 170, 185, 192, 193, 194, 195, 197, 225, and 228. For further details concerning this subject see Chapters 11 and 12.

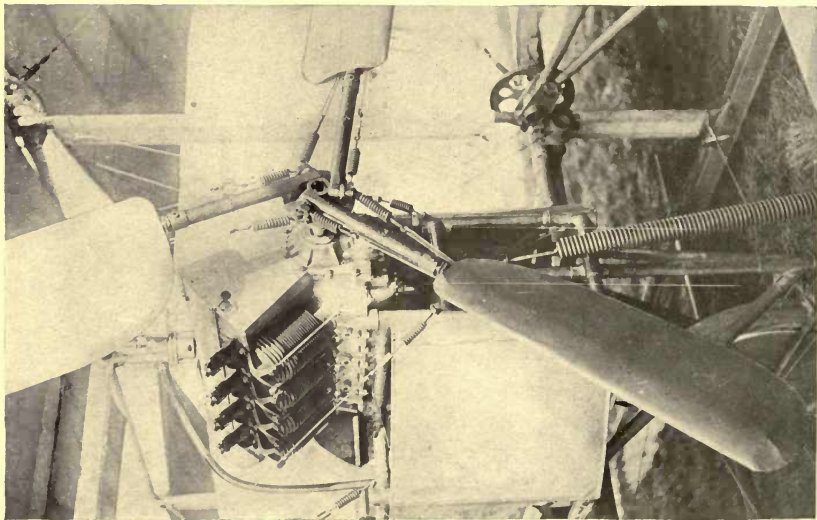

FIGURE 98.—Three-bladed Propeller. This odd propeller, built of steel arms and framing on which sheet metal is fastened, is used on the Breguet biplane.

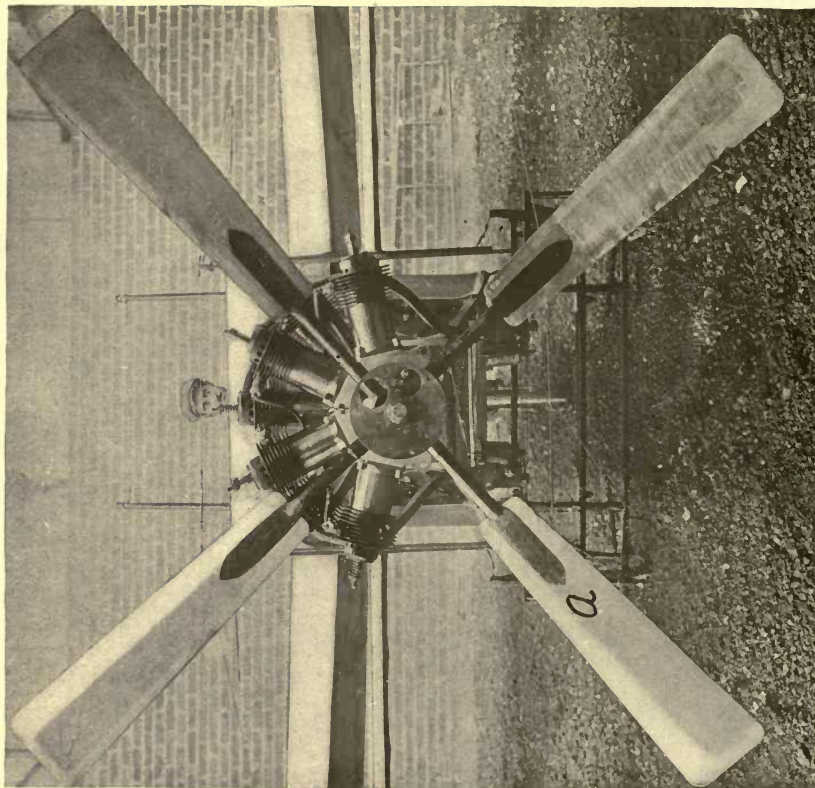

FIGURE 99.—Four-bladed Propeller. This propeller, of R. E. P. construction and driven by an R. E. P. engine, is one of the few examples of a successful four-bladed propeller. The blades *a* are of magnesium, fastened into steel arms.

CHAPTER FIVE

PROPULSION

Present-day workers in aeronautics have almost without exception achieved their conspicuous successes with machines definitely driven through the air by suitable propellers, the power for which is supplied by light-weight engines. This is true of both heavier-than-air and lighter-than-air machines though in the case of the aeroplane there is much evidence of mysterious and little-understood laws—upsettings of the very fundamentals of established theories of force and motion—which in the opinion of at least a few investigators of the highest standing promise that man will ultimately achieve the indefinite gliding flight of the great soaring birds. This question, however, is one that calls for only casual comment here, it being more fully discussed in Chapters 4 and 6 (see Pages 164 and 169. It is enough for the present purpose to assume that, present flying machines requiring propulsion, it is of importance to consider and define the best method of securing such propulsion.

MISCELLANEOUS PROPELLING DEVICES

Though the screw propeller is the only device that has come into extensive use or met with any

considerable success in the propulsion of aerial vehicles, it is by no means the only device that can be applied to the purpose. Such other mechanisms as have been developed, though, are interesting more because of the theoretical alternatives they present rather than because of anything practical in either their promise or their performance.

Of the miscellaneous propelling devices that are important enough to be considered there are three chief classes—reciprocating wings and oars, paddles, and undulating or wave surfaces.

FEATHERING PADDLES

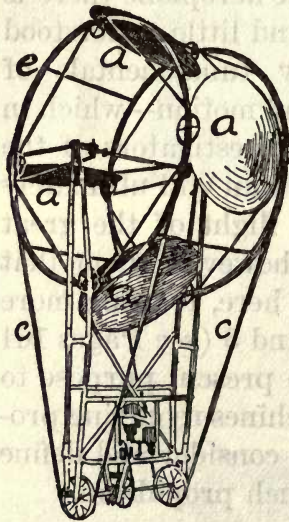

FIGURE 90. — Feathering Paddle Flying Machine. By the rotation of *e* by the belt *c* it was expected that the paddles *aaa* would sustain the weight by beating down on the air, it being noted that they come down flatwise but rise edgewise through the action of the feathered mechanism.

Feathering paddles, in a measure like those used for boat propulsion, have been proposed for propelling and lifting flying machines. An example of one for both propelling and lifting is pictured in Figure 90. In all devices of this character the principle is that of a plurality of surfaces carried rapidly around in a revolving structure, within which they possess a secondary movement that causes them to travel flatwise when going downwardly or rearwardly and edgewise when traveling upwardly or forwardly. A

simplified modification of this idea is the use of an ordinary paddle wheel in a housing, as shown in Figure 91, the idea being that its exposed portion

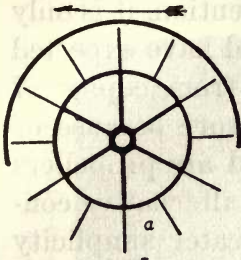

FIGURE 91.—Partially Housed Paddle Wheel. Proposed for propelling in direction of large arrow by effect of exposed blades at *a*.

at *a*, revolving as shown by the small arrow, will produce a forward drive in the direction of the large arrow. It is almost needless to assert that all devices of this general character so far built are heavy, complicated and inefficient.

WAVE SURFACES

A somewhat peculiar and very interesting type of propelling or sustaining mechanism is that suggested in Figure 92, in

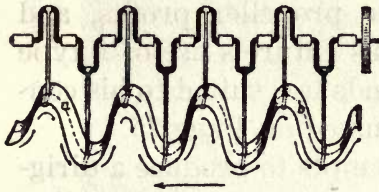

FIGURE 92.—Wave Surface. Proposed for propulsion, the progressing sinuosity of the surface *a b* being expected to effect travel in the direction of the arrow.

which *a b* is a flexible surface, of length and width enough to present considerable area, made capable of rapid undulation by suitable mechanism with the idea of causing it to progress through the water. The almost hopelessly difficult problem of contriving durable, reliable, and efficient mechanism for effecting the undulation required is probably a far greater bar to a practical result than any defect in principle. A flying machine in which this principle was involved was that of F. W. Breary, secretary of the Aeronautical Society of Great Britain in 1879.

RECIPROCATING WINGS AND OARS

Reciprocating wings being the mechanism by which birds, insects and other flying animals secure propulsion, and in many cases sustentation, it is only natural that many designers should have expected to derive satisfactory operation from copies of the mechanism of nature. But, more because of the efficiency of properly designed air propellers than because of the inefficiency of alternative constructions, and because of the greater simplicity and reliability of the simple rotating device, few engineers of real standing have been able to convince themselves of any material advantages to be gained by recourse to the more-complicated and less-promising wing propulsion. Another basis of comparison by which the propeller profits, and which incidentally explains nature's use of a type of mechanism that man finds less suited to his constructing abilities, is discussed on Page 25.

One of the earliest attempts to produce a dirigible balloon involved the use of reciprocating wings, the ascent being that by Blanchard, on March 2, 1784, from Paris (see Page 72). These wings being worked by man power, it is almost unnecessary to remark that the attempt ended in complete failure.

Both before and after the foregoing, hundreds of investigators have sought to secure sustentation or propulsion, or both, from the action of reciprocating wings. Such success as has been secured, however, has been very small, though it is to be admitted that reciprocating wings used merely for

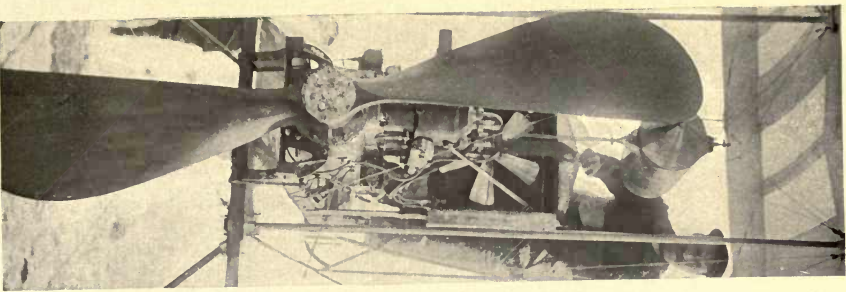

FIGURE 100.—Chauviere Walnut Propeller.

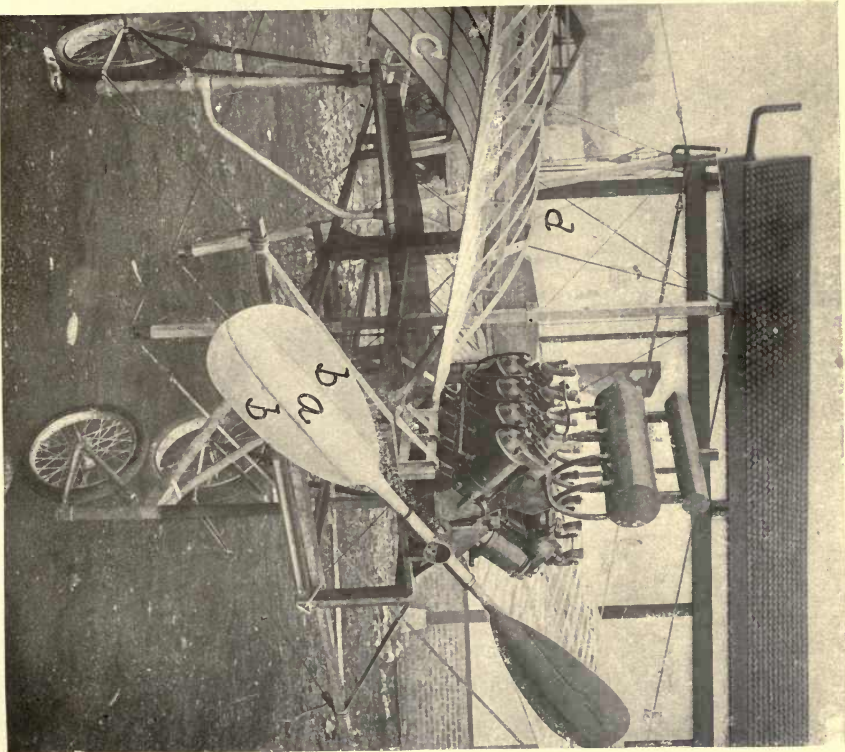

FIGURE 101.—Propeller, Engine, and Wing Frame of Antoinette Monoplane. The blades *bb* are autogenously welded.

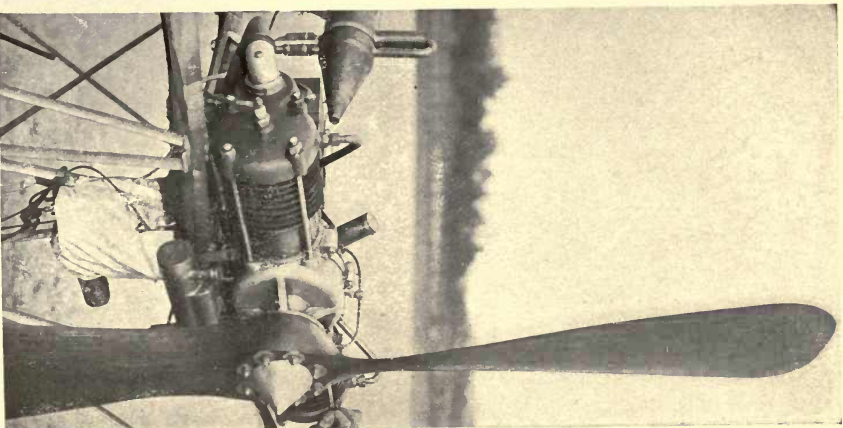

FIGURE 102.—Engine and Propeller of Santos Dumont Monoplane.

propulsion have usually afforded results much superior to any that have been attained in constructions intended to lift as well as propel by the use of this type of mechanism.

Undoubtedly the most successful use on record of reciprocating wings was their employment as propelling elements in the various model flying machines built and flown by Hargrave (see Page 122), which flew well for distances limited only by the ability to carry fuel. The wings used on the most successful of the Hargrave models were normally straight and flat, the curvature and varying angles of action desirable to produce the best effect being had only to the extent that the wings deformed with a feathering action under the pressures and the inertia effects involved in the rapid flapping, thus skulling the whole machine along through the air.

The highest speed of reciprocation secured with the Hargrave machines was 248 double beats a minute with a 36-inch wing, weighing only a few ounces, and moved through an arc of not over 80° , corresponding to a tip speed of possibly 1300 feet a minute—fully twice that of the wings of any flying animal, which Marey and Lendenfeld have shown move with remarkably little variation at about half this speed, the proportioning of wing length to rate of vibration being invariably so arranged as to produce this result. Thus the bee, with a wing length of about $\frac{1}{4}$ inch, makes 11,400 beats a minute; the sparrow, with a wing length of about 4 inches, makes 720 beats a minute; and

the stork, with a wing length of 27 inches, makes 105 beats a minute. When it is discovered that $\frac{1}{4} \times 11,400 = 2850$; $4 \times 720 = 2880$; and $27 \times 105 = 2835$, at least a glimmering of the law is very apparent.

It is a safe generalization, based upon known facts of engineering, that tip speeds materially higher than those secured by Hargrave are not likely to be attained in any durable reciprocating-wing mechanism. On the other hand, revolving propellers are safely worked at peripheral speeds of 40,000 feet a minute. Even Hargrave has admitted "that the screw and the flapping wings are about equally effective as instruments of propulsion"—despite the fact that he, undoubtedly the foremost experimenter with ornithopter propulsion, tried propellers now known to be exceedingly inefficient.

SCREW PROPELLERS

Clearly, the surfaces of propeller blades are directly analogous in their action upon the air to the action of aeroplanes traveling in helices (when the machine is traveling; in circles when it is still) of diameter so small that there is more or less material difference in the circumferences of the concentric paths traversed and in the consequent relative speeds of the portions of the blade surfaces traversing them. These considerations therefore indicate that the problems of propeller design must involve all the complex problems of ordinary aeroplane supporting surfaces in addition to other

intricate factors introduced by the elements of centrifugal force, the screw form necessary to conform to the peculiar path of travel, and the varying relative speeds of the different portions of the surfaces.

SOME COMPARISONS

Much confusion has existed in the past and still exists in the minds of the uninformed who fail to distinguish between the functions of air propellers and the functions of similar but not analogous mechanisms. To clear away this confusion, it should be understood that here are three possible devices of the same general appearance but adapted to quite different purposes. First of these is the ordinary windmill wheel, designed to rotate from the reactions occasioned by a cylindrical stream of air flowing through its circle of rotation; second is the revolving fan, which is theoretically and practically the opposite of the windmill wheel, it being designed to produce a current by, so to speak, shearing loose a cylinder of air from the surrounding air and forcing this cylinder of air to flow through its circle of rotation; and third is the air propeller, bearing no such close relationship to the other two devices as they sustain to each other—an air propeller being intended in a strict sense neither to react from disturbed air flowing through it nor to cause a flow of air, its proper function being that of progressing with its attached mechanisms through the air with a minimum disturbance—as nearly as possible like

a screw in a solid nut. Unavoidably, when first started or when traveling slower than its proper pitch speed, an air propeller must operate as a more or less efficient fan, but under ideal conditions of proper functioning its blades will slide through their helices of travel (see Page 239) with no disturbance of air but that due to the compressions and neutralizing reactions against their effective surfaces.

ESSENTIAL CHARACTERISTICS

The essential characteristic of a screw propeller being its perfect adaptation to travel in a helical path, it follows that in addition to conforming as nearly as may be to other considerations of design it must also partake of the character of a true screw, the elements of which therefore demand examination.

If the path of *a*, Figure 93, at the extremity of a revolving and advancing propeller blade, be described in the interior surface of a hollow cylinder its appearance will be that of the solid line *c*, from which it is at once evident that there are for any possible screw several fundamental factors. One of these is the extreme *diameter*, which determines the diameter of the cylinder of air through which progression is effected; another is the *pitch*, which is the amount of advance per revolution; and a third is the *angle of blade travel*, which clearly bears a direct determining relation to the pitch and therefore can be expressed by the

percent the pitch is of the circumference. Continuing the examination, it develops that a point in a propeller blade, as at *d*, not at the extremity of the blade and thus compelled to travel the smaller dotted helix *c*, must nevertheless advance the same axial distance per revolution as the point *a*, because the propeller as a whole, including all

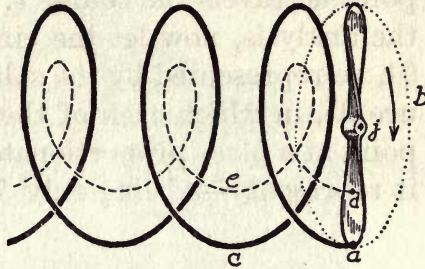

FIGURE 93.—Helices of Propeller Travel. The point *d* takes the course *c*, and the point *a* the course *c*, in advancing through the air.

points within it, is an inflexible mechanical unit, all parts of which must therefore progress at a uniform rate along the axis of the invisible cylinder of air.

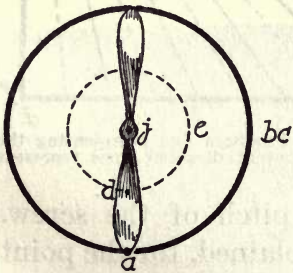

FIGURE 94.—Circles of Propeller Travel. The point *d* takes the path *c*, and the point *a* the path *bc*, when the propeller is restrained from advancing.

But since *e* is (in the proportions sketched, and considered as a circle) only one-half the diameter and circumference of the helix *c* the given advance with only half the rotational travel requires that the angle of blade travel at *d* must be twice that at *a*, while the angles at all other points

along the blade lengths must similarly vary in direct proportion with the varying helices traveled. This may be more apparent in the end view, Figure 94, of the propeller and helices, in which the helical paths of the blades appear as circles—as

indeed they become if the propeller is permitted to revolve while kept from advancing. In this figure the point *a* travels the course *bc* and the point *d* travels the course *e*. Further to simplify the analysis, now let the circles *bc* and *e*, Figure 94, be represented by the solid lines *bc* and *e*, Figure 95, in which each of these lines starts from a point at a place proportionate to the circumference it represents—*e* being only .7 as long as *bc*—while

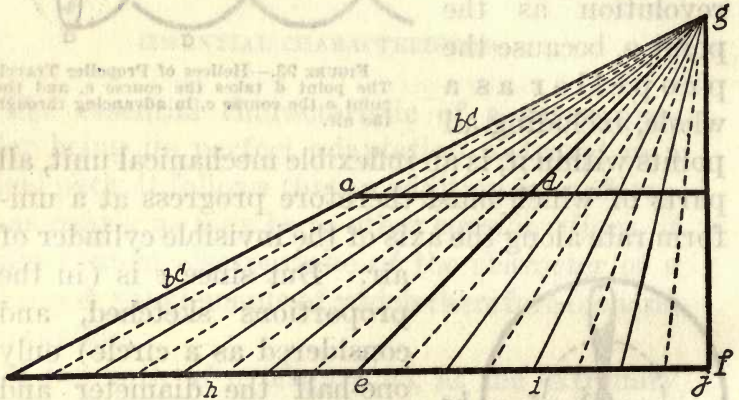

FIGURE 95.—Diagram of Propeller Pitch. The base line representing the circumference of the propeller circle, the different diagonal lines represent the angles of travel of different blade portions.

the distance *fg* equals the pitch of the screw. Obviously now, as has been explained, for the point *d* in the propeller blade to travel from *f* to *g* in the distance *eg* it must be inclined at twice the angle called for at *a* to make the distance *fg* in going the length of *bc*. Intermediate portions of the blades, having to travel along circumferences represented by the infinity of dotted lines suggested at *h* and *i*, will correspondingly call for an infinity of angles of travel corresponding to the angles of

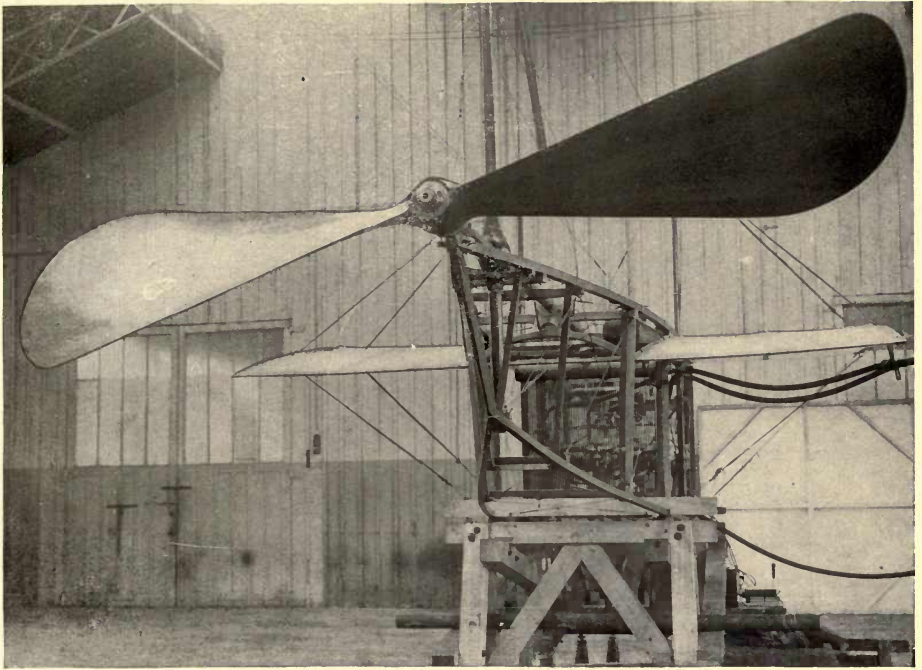

FIGURE 103.—Wooden Propeller Applied to Car of Clement Dirigible Balloon.

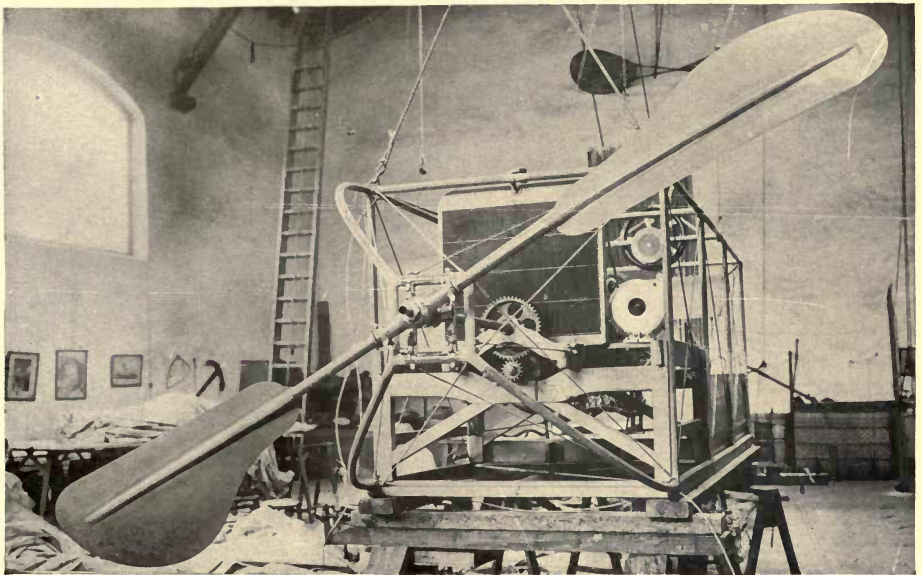

FIGURE 104.—All-Metal Propeller Applied to Dirigible Balloon. This is a somewhat unusual construction, involving hub arms welded to the rarefaction surface of the sheet-metal blades. It constitutes an interesting example of an attempt to secure results with the highest possible grade of material in combination with a most modern method of assembling.

h i, giving to the theoretically correct blade a gradual twist of blade travel, increasing from a blade travel parallel with the propeller axis at the exact propeller center *j* to a surface traveling at the pitch angle at the propeller tip *a*.

A very curious development in propeller practise has been the highly-successful use of propellers with "straight pitch"—that is, with blade angles not varying from hub to tip, thus defying most theories of propeller construction. It was with such a propeller, of uniform blade width, that Glenn Curtiss flew at Rheims, France, in August, 1909, on which occasion it was experimentally determined that a scientifically designed and perfectly constructed Chauvière propeller, such as was used by Bleriot in crossing the English Channel and by Farman in his 118-mile flight at Rheims, materially slowed Curtiss' biplane. The explanation possibly is to be found in some not-understood flows of outer cylinders of air over concentric cylinders of air within them.

Effective Surface of a propeller is that portion of the circle swept by the blades against which thrust is developed. For two principal reasons there is little advantage in attempting to make effective surface of the whole of the circle. One reason is that the speeds and angles of blade travel towards the center of the circle are too slow and too inclined to produce material thrust with any form of blade surface that it is possible to devise. The other reason is that—the areas of circles varying with the squares of their diameters—very little

area is lost in eliminating from thrust consideration considerable portions of the inner ends of the propeller blades. Thus, if one-half of the blade length, from j to d , Figure 94, is eliminated from consideration as thrust surface, three-fourths of the area of the circle $a b c$ is still retained—the circle $d e$, swept by $j d$, being only one-fourth the area of $a b c$, three-fourths of which is swept by $d a$.

Angles of Blades in an aerial propeller should not be the same at given points as the corresponding angles of blade travel, though it has been a common mistake to assume that they should. The reason of this becomes most apparent by consid-

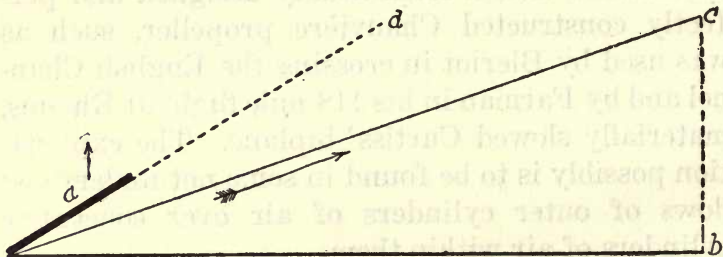

FIGURE 96. Angle of Propeller-Blade to Angle of Travel. With the blade moving in the direction of the large arrow, it is obvious that to produce a thrust in the direction of the small arrow the blade a must be inclined to the pitch, or line of travel.

ering the passage of a blade through the air as though it were an ordinary aeroplane surface moving in a straight line, as in Figure 96, in which a is a section of the blade, b is its plane of rotation, c is its pitch or angle of travel, and d is its angle of inclination to its angle of travel. This necessary difference between blade angle and angle of blade travel has given rise to a number of com-

plicated misconceptions, chiefly noticeable in the confusion it has occasioned in estimates of propeller pitch and slip (see Page 244). Yet the distinction becomes very apparent when Figure 96 is tilted so that c can be regarded as a horizontal path along which a is traveling in the direction of the large arrow. This point of view gained, it is an obvious absurdity to expect a to exert a pull in the direction of the small arrow unless it is thus inclined to its path of travel.

The amount of inclination necessary in a propeller blade varies just as it does in an aeroplane in accordance with several factors, chief among which are the speed of travel, the width of blade section, and the form of blade section. It consequently is a safe generalization for the designer to assume that the inner and therefore slower-moving portions of effective blade surface must present greater inclination above the screw-pitch line than the outer and faster-moving portions of blade surface, that wide surfaces probably require less inclination than narrow ones (at given speeds), and that the greater effect of properly-curved sections can be approximated with flat and wrongly curved surfaces only by the use of excessive inclinations, and then only at the cost of wasteful power application.

Failure to give due regard to the question of blade inclination gives rise to overestimates of slip in all cases when the pitch, or angle of blade travel, is confounded with the angle of blade setting. A propeller designed with the blade angle the same

as the supposed angle of blade travel naturally fails to operate at the pitch that is calculated for it, with the result that in subsequent trials this discrepancy between the real pitch and the supposed pitch is discovered, added to such actual slip as does occur, and the total set down as all slip.

Slip is a phenomenon that presents itself in all mechanisms, of whatever type, in which it is sought to produce positive movements or reactions in fluids—liquids or gases—by the action of solid parts. An air propeller, for example, caused to travel through an internally-threaded cylinder of metal would in fact as in theory progress without slip—making the definite and invariable advance demanded by its pitch for each revolution or part of a revolution accomplished. Working in its proper element, however, a body of yielding air, the amount of the yield causes a lagging behind the theoretical rate of pitch advance, this lagging varying with the design of the propeller and the conditions of its operation. Naturally the minimization of slip is an important element in the problems of propeller design.

The amount of slip varies in different propellers, and at different speeds of working, from ten to fifty percent. Ordinarily, about fifteen percent slip is to be regarded as a small figure.

FORMS OF SURFACES

In the study of propeller design, after more fundamental questions are disposed of there at once appear the no less important questions con-

cerning the details of propeller-blade forms. Evidently an infinite variety of sections and outlines are to be had, so it becomes necessary to select on as reasonable grounds as may be reached the particular combinations best adapted to afford required results. At the present time, considering the state of aerodynamic science, it is not possible to define positively and logically, by any true scientific methods, the constructions of the highest value. Consequently, recourse has been had to more generalized and tentative methods of reasoning, supplemented by empirical investigation—by experiment. As a result certain important facts are fairly well established—though the number of these that are common knowledge is possibly less than is possessed more or less in secret by several advanced investigators.

Plane Sections, as in the case of aeroplane surfaces, were the first employed by early designers of air propellers, but as time went by and progress became more and more definite, the same objections that were found to apply to flat aeroplanes (see Page 171) were found also to apply to flat propeller blades, which in consequence have been discarded by all but ignorant or uninformed experimenters.

Parabolic Sections, modified or absolute, having now become the most approved form for aeroplane surfaces (see Page 173) after years of unsuccessful experimentation with flat surfaces and with other curves, also are coming to be regarded (though in this particular application perhaps less

well established as yet) as the correct ones for propeller blades. This being the case, the same general principles that have been found to apply in the design of sustentation surfaces (see Page 188) also are found to apply to the cross sections of propeller blades—with certain modifications introduced by the necessity for traveling in the circular or helical path, which most particularly involves a more extreme application of the principle of cutting back the front of the curves at the ends of the surfaces, because the curved path and the centrifugal action both tend to augment the escape of air around the ends (see Page 189).

Air propellers being subjected to considerable loading in the way of their ordinary duty, besides to enormous centrifugal stresses set up by their unavoidable high peripheral speed, it is commonly necessary to construct them with blades very thick in proportion to width. This difficulty, especially marked in the use of strong but bulky materials, such as wood, further increases the importance of discovering and applying correct and efficient sections.

Blade Outlines are the theme of more dispute and of many more differences of opinion than prevail in the case of propeller-blade sections. Deduction from present practise is informing as much in the tendencies it discloses as it is in particular examples. Of these tendencies there is that of reducing at least a third and often the inner half of each blade to a mere arm or stem of the blade surface proper, this stem being made stocky and

strong, and shaped to go through the air with a minimum resistance, rather than to produce any measurable thrust. The portion of the blade designed to produce the thrust is commonly made widest at its middle, the inner end narrowing into the stem and the outer end narrowing to the tip. The object of narrowing the tip is twofold—first because the tip travels at the highest speed, making a given area at this point perform the greatest work (besides which a wide tip possibly increases the skin friction rather materially); and second because wide tips greatly add to the centrifugal stresses without adding at all to the strength of the structure. An increasing minority of designers prefer to make the entire advancing edge of each blade perfectly straight—lying along a radius drawn from the center of rotation—contending that this form is beneficial in that it causes the edge to meet all air particles at right angles, without setting up side flows and eddies in the concentric zones or helices of air through which the propeller passes. With a straight advancing edge, the following edge of a blade must be irregular, since its contour alone must provide for all required variations in width and area. This consideration causes a decreasing majority of designers to dissent from the theory of the minority, and divide differences of area more or less equally between the advancing and following edge contours. In the matters of total and effective blade area, the undoubted tendency at present is to increase speeds and correspondingly reduce areas. In a past era of

inefficient multibladed propellers it was not uncommon for half or more of the area of the circle of rotation to be occupied by blade width, but in modern two-bladed, more-efficient propellers the blade width often is as little as one-tenth or one-twentieth of that of the circle of rotation.

MUTIBLADED PROPELLERS

It seems to be established to the satisfaction of most modern engineers that the fewer the blades in an air propeller the nearer ideal its conditions of operation—too many blades tending to interfere with one another by their close proximity requiring each to work against air previously disturbed by the blade preceding. The condition is similar to the case of an aeroplane with identical advanc-



FIGURE 97.—Advancing and Following Surfaces. Showing the necessity for a different curve and steeper angle in the rear wing, that it may operate effectively through air disturbed by the front wing.

ing and following surfaces closely spaced in the same plane, as at *a b* and *c d*, Figure 97, rendering it necessary for the rearward surface to derive its sustentation from air to which a downward movement has been imparted by the forward surface. In the case of the aeroplane correction can be effected by making the rearward surface of a different curve from that forward and by inclining it at a greater angle, as in Figure 97, but this solution

obviously is not applicable to the equally-spaced propeller surfaces, all of which are both advancing and following because of their rotary travel. The one other possible solution of the problem presented in Figure 97 is to increase the spacing of the blades, which in a propeller can be done only by increasing their length or reducing their number, or by a combination of these.

A modern three-bladed propeller is shown in Figure 98 and a four-bladed construction in Figure 99. Though used with some success, neither of these meet the approval of the most successful experimenters.

TWO-BLADED PROPELLERS

Two blades in a propeller is the least number compatible with smooth running, as a one-bladed propeller inevitably must be badly out of balance in so far as concerns maintenance of a fixed center of thrust—while gyration of the center of mass could be prevented only at some critical speed by the altogether unwarranted expedient of a counterweight. For these reasons two blades, oppositely placed in the same plane or other figure of rotation, are the least that can be used, and are generally preferred, though four-bladed propellers have some slight vogue and three-bladed ones are occasionally met with. Modern two-bladed propellers of successful forms are illustrated in Figures 100, 101, 102, 103, and 104, in which characteristic examples of all the more approved constructions are clearly shown. A close scrutiny of these will prove informing to the student of the subject.

PROPELLER DIAMETERS

Mechanically considered, the limiting factor in propeller speed is peripheral speed rather than rotational speed, since it is primarily upon this that the centrifugal stresses, which are by far the most severe of all involved, depend. The propellers of practically all successful aeroplanes yet built are run at peripheral speeds of from 12,000 to 40,000 feet a minute, with occasional instances of speeds of over 50,000 feet a minute, the rotational speeds being so adjusted to the diameters as to produce little variation outside of the range given. At the higher of the speeds mentioned—nearly 570 miles an hour—the centrifugal pull exerted at the blade tip is enough to test the qualities of the finest structural materials available.

That it is better to gain the permissible peripheral speeds by the use of large-diameter propellers at low rotational speeds, in preference to small propellers at high rotational speeds, becomes very evident with a little study. Consider, for example, the case of a portion of a propeller surface, one foot long and one foot wide, traveling edgewise around a thirty-foot circumference 600 times a minute—it being assumed that a peripheral speed of 18,000 feet a minute is as high as it is considered expedient to use in the given case. With the conditions stated the surface passes any given point ten times a second—often enough to produce material disturbance of the air worked against. Now assume the circumference reduced to fifteen feet

by a corresponding halving of the propeller diameter and immediately it becomes apparent that a doubling of the rotational speed is allowed without increasing the peripheral. But with this done the assumed propeller surface passes any given point twenty times a second—twice as often as before—with correspondingly reduced assurance of finding undisturbed air to work against. Moreover, since the blade surface travels the same distance in the same time in both cases, there is no opportunity to reduce its area on the ground of the higher rotational speed in the small propeller. The result is that the blade, which is of a width only one-thirtieth the length of its path in the large propellers is in the small propeller one-fifteenth of its length—a condition that operates directly against maximum effectiveness. Of course it is reasonably to be urged that when a propeller is progressing through the air in its normal condition of operation, instead of revolving in a circle as when kept from advancing the blades travel separate helical paths, wholly distinct from one another. But these paths are nevertheless closely adjacent, and become more closely adjacent with every increase in the number of blades and every decrease in the pitch. From these considerations it must be evident that large diameters and small blade numbers reduce the frequency of the successive traversals of the adjacent helices, and consequently the frequency and adjacency of the air disturbances. A practical limit is set, however, by the space that is occupied by very large propellers.

ARRANGEMENTS OF BLADES.

In considering the design of aerial propellers it at once becomes evident that there is possible a considerable variety of blade arrangements. Not only may the blades differ in their number, in their outlines, in their cross section, in their pitch, and in their angles of setting; they may also differ in the angles they make with their plane of rotation, in their longitudinal placing on the propeller shaft, and in the use of longitudinal sections—from hub to tip—that are straight or curved.

Right-Angled Propeller Blades, at right angles to the propeller shaft, as in *A*, Figure 105, are the commonest form. The advantage of this construction is that the centrifugal stress exerts a direct

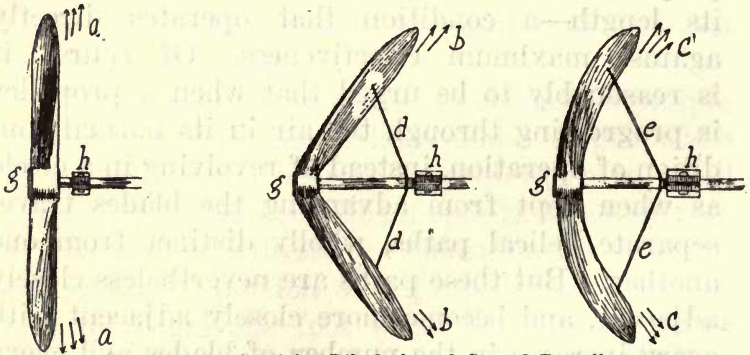

Figure 105.—Straight, Dihedral, and Curved Propellers.

pull from the hub, without any tendency to move the blades longitudinally, parallel with the axis of revolution. A supposed disadvantage is the radial escape of air from the propeller tips, as suggested at *a*, without helping in propulsion. But since such radially-thrown air is more apparent

when the propeller is kept from advancing, and is thus worked as a blower, than it is under normal conditions in which the propeller goes through the air instead of the air going through the propeller, it probably is not deserving of serious consideration. In fact the air can be thrown radially with this type of blade arrangement only to the extent that it is dragged by skin friction or by incorrect propeller section, the first of which is probably not an effect of great magnitude and the second of which is a subject for improved design.

Dihedrally-Arranged Propeller Blades, set at an angle as at *B*, Figure 105, or curved as at *C*, Figure 105, obviously utilize the radially-thrown air at *b b* and *c c* in propulsion, but though they utilize it they must also increase the amount of it by subjecting the air behind the blades to direct centrifugal action as well as to the mere skin friction that applies in *A*, Figure 105. Moreover, they require very stiff blades, or else stay wires as at *d d* and *e e*, to prevent the blades from straightening up under the powerful centrifugal pull. The presence of the wires is an added objection in that these set up material resistance to the rotation, besides which they add the distance *g h* to the necessary overhang of the propeller from the bearing *h*.

PROPELLER EFFICIENCIES

The efficiency of aerial propellers is a factor of the utmost importance in aeronautical engineering because of its relation to power required, which in turn involves the questions of engine weight and

fuel quantity, all of which finally decide the possible radius of travel without alighting. The measurement of efficiency is theoretically very simple, though practically not without some difficulties, the essentials being the thrust developed and the speed of movement, which, when multiplied, give the foot pounds utilized per unit of time. Comparison of these with the horsepower developed affords a direct measure of the efficiency. Thus it has been stated that in the Wright aeroplanes the propellers produce a thrust of 160 pounds at 40 miles an hour when driven by the 30-horsepower engine. Assuming these figures to be correct—though that concerning the thrust is probably overestimated—the speed of 40 miles an hour is equivalent to 3,520 feet a minute. This multiplied by the 160 pounds requires 563,000 footpounds a minute, which, compared with the engine output of 990,000 footpounds a minute, indicates an efficiency at the propellers of about 57%. If the engine develops only 25 horsepower, as has been asserted, the efficiency figures nearly 65%. That these figures are incredibly high will be appreciated when it is considered that they represent not merely the propeller efficiency but the combined propeller and transmission efficiency—with a type of chain transmission quite wasteful of power.

The explanation probably is that so high a propeller thrust as 160 pounds is altogether beyond what would be required to overcome the resistance that should be encountered, and, if developed, its necessity is to be explained only on the theory that

to the unavoidable head resistances there must be added a considerable avoidable resistance due to the use of inadequate or wrongly-curved sustaining surfaces, made to serve only by being dragged through the air at unduly steep angles of incidence to the path of movement (see Page 133).

In spite of the difficulties that have been encountered during the experimental period of aerodynamic science it has been long established that properly-designed air propellers afford much higher efficiencies than ever have been realized from water propellers, it being a fully demonstrated and rather amazing fact that with a given engine power an aerial propeller on a boat can be made to afford a higher thrust than any known form of water propeller that can be provided.

The Effects of Form on aerial propeller efficiencies are very marked, and, though it cannot be said that the best forms have been finally determined, enough experimenting and testing has been done to disclose the widest possible differences in the efficiencies of the different blade sections, outlines, pitches, etc., that have been tried.

The Effects of Rotational Speed on aerial-propeller efficiencies having been discussed at some length on Page 250, it is enough to add here that up to some unknown limit the more rapidly a blade surface travels through the air the more perfect the reaction from the stratum of air behind the blade, and, incidentally, the thinner this reactive stratum—a phenomenon that has important bearings on the question of interference between a

plurality of blades. The head resistance to the blade edges and the skin friction on their surfaces increase with the speeds—the former about with the square of the speed and the latter probably at some much slower rate.

As a rough general rule it can be stated that the power required to drive a driven propeller cubes with increase in speed, a doubling of the propeller speed doubling the amount of air acted upon, doubling the speed at which it is acted upon, and doubling the rate of progress through the air.

The Effects of Vehicle Speed upon aerial-propeller efficiencies are especially marked when the relations of pitch, propeller speed, and vehicle speed are such as to compel an abnormal amount of slip. Thus, when the vehicle is kept from moving at all the slip is 100%, and the propeller works as an air blower, driving a cylinder of air to the rear at a rate equivalent to the propeller pitch minus its slip considered as a blower, not as a propeller. If under this condition the resistance of the cylinder of air to being sheared loose, so to speak, from the surrounding air, and compressed against the air to the rear of it, is greater than the head and other resistances of the vehicle at any given speed, the propeller thrust under this condition may be much greater than can be reasonably expected under the altogether different conditions that prevail when the propeller is moving through the air instead of the air moving through the propeller.

In the opinion of some, failure to consider these

points has been the reason for many unwarrantedly high estimations of propeller efficiencies, based upon tests made with the propellers restrained from movement in an axial direction and revolved in air possessed of no movement other than that produced by the propellers themselves. However, it is only fair to state that Maxim and others vigorously oppose the claim that there is enough difference in the conditions to invalidate tests made of propeller thrust with the propeller not advancing.

The greater thrust that ordinarily can be secured from propellers restrained from progressing at their pitch speed is one of the strongest arguments that can be adduced in favor of the helicopter principle, the helicopter being intended to derive sustentation from the reactions under one or more horizontally-revolving propellers rising through the air at much lower speeds than would result from a rate of progress equivalent to the pitch (see Page 244).

The Effects of Skin Friction upon aerial-propeller efficiencies are much less of a factor than they are in water propellers, being probably almost negligible, unless at the most prodigious speeds, though there are a few authorities who hold to a contrary view. Moreover, in further dissimilarity from the conditions that apply to water propellers, skin friction is but little dependent upon extreme smoothness of the propeller surfaces. This is because the cohesion of the air is so low that only a small amount of energy can be expended in sliding

one portion of it upon another, even should it be the case that instead of the propeller surfaces sliding through the air they carry thin air films with them, dragged along by occasion of more or less imperceptible deviations from the unattainable ideal of perfect smoothness.

Determinations of skin friction can be best made by revolving at high speeds flat propeller-like surfaces without pitch, though in making tests of this sort it naturally is most important that proper allowance be made for the other resistance factor—the head resistance of the edges of the surfaces.

PROPELLER PLACINGS

The matter of propeller placing is one that admits of a considerable variety of schemes, with a considerable diversity of opinion as to which scheme is best. Maxim, for example, opposes the front-placed “tractor screw” on the ground that it “fails to take advantage of air set in motion by the machine as a whole, as a means of neutralizing some of the normal slip.” Pelterie, on the other hand, contends “that the wake from the slip itself is turned to better account with a tractor screw because it creates a higher efficient velocity of air under the center of the main wings.” To the writer—in which opinion he is upheld by others—it seems probable that both of the foregoing views are based upon exaggerated estimations of slip, which with modern well-designed propellers probably is very small at normal vehicle speeds. In

this opinion he is further borne out by the fact that there are highly-successful modern aeroplanes of both the thrust-screw and the tractor-screw types, though the only examples of the former are the Wright, Curtiss, Cody, and Farman machines, now that the Voisins have gone over to the tractor-screw design. But that Pelterie's theory is not without a measure of plausibility is rather interestingly suggested in the starting system recently patented by Bleriot (see Figure 169).

Single Propellers, being necessarily placed at or near the center of the head and other forward resistances to the progress of an aeroplane, can under no conceivable circumstances drive the machine materially out of its course, as is always dangerously possible with two propellers (unless arranged in tandem on the same axis) should one or the other for any reason become inoperative and so fail to maintain its normal share of the thrust. It was a condition of this sort, arising from the breakage of one of the propellers, which occasioned the first fatal accident in the history of power-driven heavier-than-air fliers, in which Lieutenant Selfridge lost his life and Orville Wright was injured.

Plural Propellers are advocated by a few because against the use of single propellers there is to be urged the objection that a machine is unbalanced by the gyroscopic and reaction effects, it being evident that these can be readily neutralized by the use of two or more propellers, of the same form and size, symmetrically placed, and revolved

in opposite directions. That such effects exist there is, of course, no gainsaying, but the prevailing opinion of the generality of engineers at the present time is that their magnitude with propellers ranging from five to ten feet in diameter and weighing from three to twenty pounds (with a large proportion of this weight in the hub), is too trifling to be seriously regarded—a view that is experimentally upheld in the fast-increasing numbers of single-propeller machines. Indeed, the Wright and the Cody biplanes (see Figures 188 and 202), which have identical propelling systems, are the only successful twin-propeller machines of large size that ever have been designed in accordance with this system, which was first seriously applied by Maxim in his great multiplane, and subsequently employed in Langley's flying models. It certainly has at least the appearance of reasonableness that a thin and narrow propeller blade, from two to five feet long, moving at high speed on one side of an aeroplane, cannot produce any considerable reaction per unit of area against a comparatively broad wing surface on the opposite side, from ten to twenty-five feet long. To analyze a particular case, let there be considered the monoplane with which Bleriot accomplished the first crossing of the English Channel. In this machine the propeller blades are about $3\frac{2}{3}$ feet long and the wing span is over 25 feet. The most effective speed of the propeller is about 1,200 revolutions a minute, at which about 25 horsepower is applied. This amount of power is the equivalent of 825,000 foot

pounds a minute, or 688 foot pounds per propeller revolution, involving that the two propeller blades encounter a maximum possible resistance to their rotation of 688 divided by 21—the approximate circumference in feet of the propeller circle. This is an approximate resistance of 33 pounds figured at the propeller tips. This load, extended to the wing tips, is the equivalent of a trifle over 8 pounds unbalanced load on one wing end, raising the weight supported per square foot of area an average of $1\frac{2}{3}$ ounces higher on one wing than on the other. Assuming a normal load of 75 ounces to the square foot, which is very close to correct, the addition of this amount unbalances the machine to the extent that the weight is only about 2% higher on one side than on the other.

Wilbur Wright having asserted that the Wright machine can be flown with fifty pounds of unbalanced weight at the tip of one wing, while Santos-Dumont has flown with a forty-pound weight at one side of the body of his little monoplane, nothing more than a slightly greater warping of the wing on one side being necessary to correct the balance, the altogether immaterial quality of the unbalanced reaction from a single propeller is as manifest in practise as it is in theory.

Referring again to the magnitudes of the gyroscopic action from a single propeller, these are dependent wholly upon the factors of propeller mass and speed. With heavy propellers they undoubtedly might become a serious factor, but with the light wooden propellers most favored they

are quite as negligible as the reaction effect. In fact, this seems even to hold true of the heavier propellers of sheet steel, magnalium, and other alloys, that are favored by some builders.

A very material addition to the gyroscopic effect due to light propellers is that due to comparatively heavy flywheels, when these are used. Thus in the Wright and Cody machines, in which plural propellers are used to balance the gyroscopic and reactive effects, there must be introduced a weight-adding element of unbalance in the flywheel, which cannot readily be eliminated from a power plant in which there is chain, gear, or any other than absolutely direct application of the power.

Nor can this question be begged by the assertion that geared-down propellers—which therefore might as well be plural—are necessary to secure the higher efficiencies known to be secured with larger diameters working over large areas at low rotational speeds. For the answer is found in the fact that in any given cases of equally sound designing the efficiency thus gained at the propeller is certain to be lost in the transmission—not to dwell upon the matters of greater weight and complication, smaller reliability, and the entry of otherwise avoided possibilities of derangement or failure of a type so dangerous as to constitute an ever-present menace in the use of machines in which this construction is employed.

Gyroscopic action is possibly most apparent in its effect upon steering, it tending more or less

markedly to deviate a machine from a desired course, when it is attempted to steer it. This deviation is always in the direction of the rotation. Thus, with a propeller rotating clockwise, as viewed from the rear of the machine, in steering to the right the prow drops and in steering to the left the prow rises. In steering up the prow draws to the right, while in steering down the prow goes to the left. With a propeller rotating counter-clockwise, as viewed from the rear, the movements in all four possible cases are just the opposite. These movements have been elaborately confirmed by Alexander Graham Bell by experi-

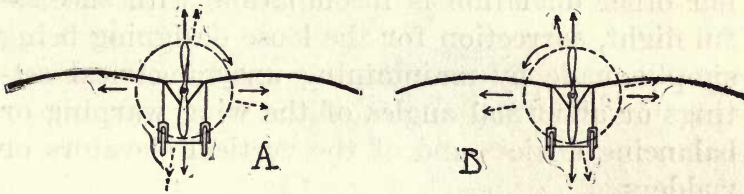

FIGURE 106.—Effect of Gyroscopic Action of a Single Propeller on Steering. With the directions of rotation shown, effort to steer in the direction of the solid arrows results in deviation in the direction of the dotted arrows, to an angular extent varying with the magnitude of the gyroscopic effect. This tendency can, of course, be allowed for by a practised operator. In both views the machine is to be regarded as approaching the observer.

ments with a small gyroscope in a case. In the practical operation of a machine, this peculiarity causes practically no trouble, the pilot learning to allow for it by always executing steering movements of an angularity sufficient always to allow for the directional disturbance. These points will be better appreciated from reference to Figure 106.

An example of tandem propellers, which may be either similarly or oppositely rotated about the

same axis, is illustrated in Figure 107. The advantages are few and the complication considerable.

Location of Propeller Thrust, which, of course, centers along the propeller axis with a single propeller and is balanced between the propellers when a plurality is used, is properly, to secure sustained flight from the thrust or traction, made coincident with the exact center of the head and other resistances and preferably with the axes of rotation parallel with the normals to the plane of resistance. In a correct design it would reasonably seem that the normal center of resistance would be chosen, but it has been demonstrated that neither angular nor other deviation is incompatible with successful flight, correction for the loose designing being simply made by maintaining unsymmetrical settings or abnormal angles of the wing warping or balancing devices and of the vertical elevators or rudders.

PROPELLER MATERIALS

Of all the possible elements in a flying machine, an aerial propeller probably most requires correct design, careful construction, and the highest qualities of materials to make it stand up under the severe stresses that are imposed on these mechanisms. In every way approach to an ideal result is restricted by the severest limitations. Weight, which is one road to strength, is placed quite out of court by the tremendously high peripheral speeds involved, which set up most terrific centrifugal loads. Thickness, permitting hollow and

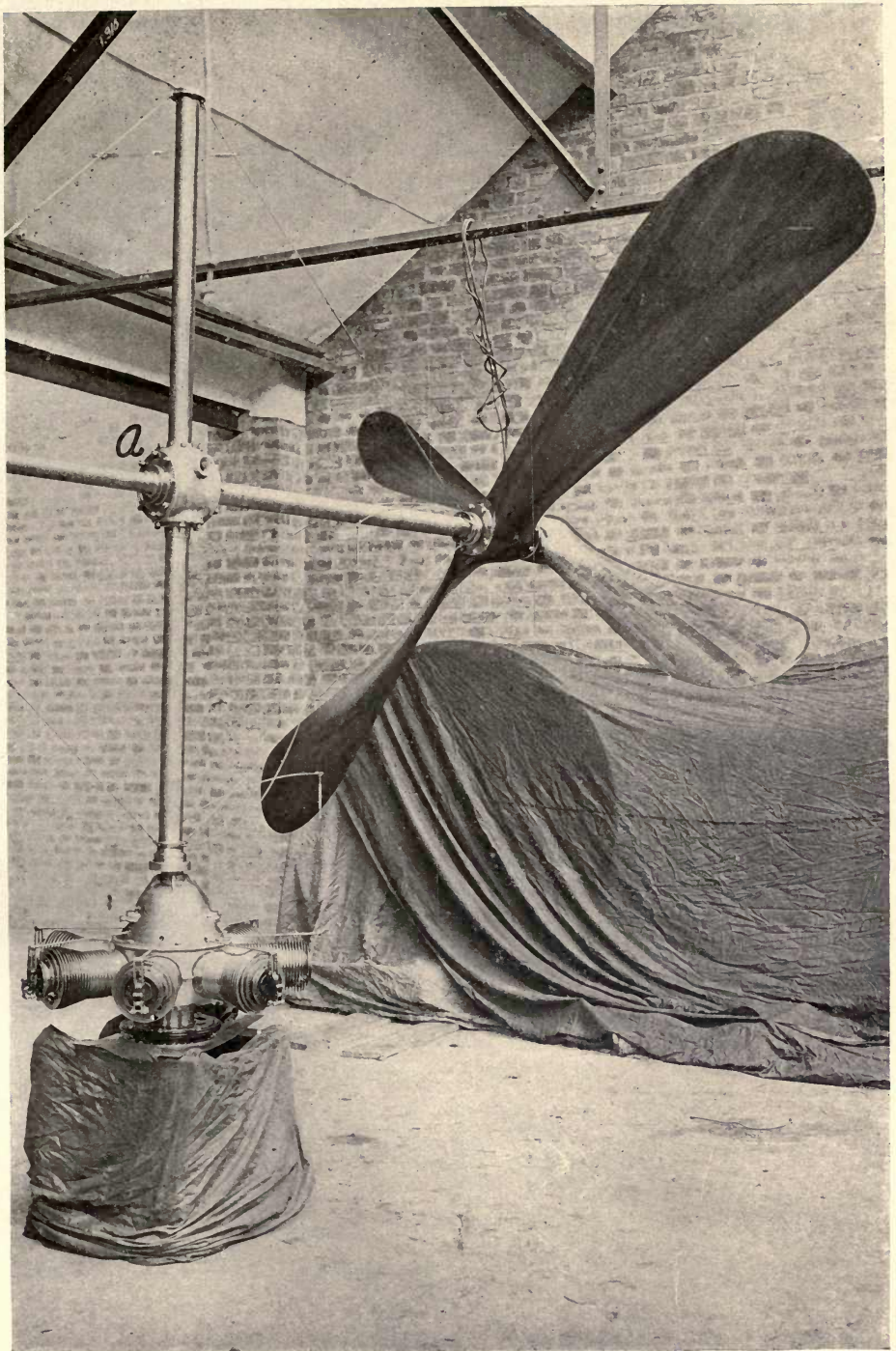

FIGURE 107.—Twin Wooden Propellers on Single Shaft, for the propulsion of a dirigible balloon. These propellers are driven by a Gnome engine mounted to revolve in a horizontal plane. The power is transmitted to the propeller shafts through bevel gears in the housing *a*.

built-up constructions, and the use of light and strong but bulky material, such as wood, is objectionable in that it greatly increases the wasteful resistances to be overcome. Restriction of size has its limits because of the tenuity of the medium acted upon, demanding the sweeping over of large areas as the only possible means of securing a requisite thrust in an efficient manner.

Obviously, the inevitable result has had to be a series of compromises, permitting the use of the best of such materials as are available while minimizing their objections.

In all propellers, no matter what the material, it is most essential that the opposed blades accurately balance, with the center of gravity exactly at the center of rotation. If this is not the case, rotation will occur about the center of gravity, around which the proper center of rotation will gyrate in a planetary path, setting up destructive vibration. In finishing metal and wood propellers the final finish or carving must be done with the utmost delicacy if correct balance is to be had. Even an extra brush stroke in painting will throw a propeller out of balance, and the paint must be correspondingly treated in polishing to correct its distribution.

Wood, being easily worked and in selected qualities exceedingly strong and reliable, is the preferred material for most modern aerial propellers. Though of course nowhere near as strong for a given section or bulk as are many metals, for a given weight it is excelled only by the finest steels

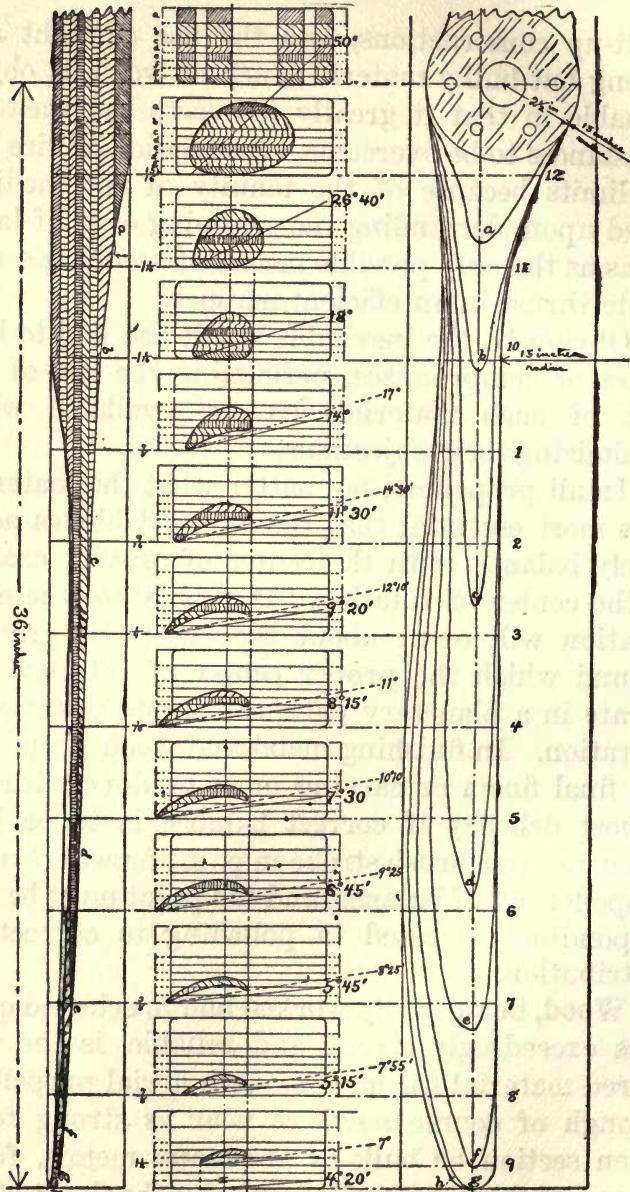

FIGURE 108.—Working Drawings of a Wooden Propeller.

(see Chapter 11). Because of this, in conjunction with the fact that the only really severe stresses on a propeller are the centrifugal, its mass works out so small in a given structure that it reduces the loads even more materially than it reduces the strength of the sections that must sustain them. This becomes very evident from a consideration of the propeller described on Page 270 and illustrated in Figures 108 and 109.

The greatest objection to wood as a propeller material is, of course, its bulk, rendering imperative the use of blade sections decidedly thicker than are most desirable.

The preferred constructions of wooden propellers involve first the production of built-up blocks from glued laminæ of selected timber, with the grain in the different layers crossed at a slight angle to prevent splitting, after which the desired form is worked out with the use of templates to insure correctness of the different sections. To some extent solid blocks have been used for propellers, and this perhaps is not bad practise with certain woods. In making built-up blocks, the individual boards should be finished with a tooth plane, to provide a slightly-roughened and interlocking surface that will promote adhesion of the glue. Then the block should be clamped under heavy pressure until thoroughly dried.

The woods considered most suitable for propellers are hickory, applewood, maple, birch, Circassian or "French" walnut, ash, and spruce. The properties and characteristics of these materials

are more fully discussed in Chapter 11, which fully treats of this subject.

Typical wooden propellers are illustrated in Figures 100, 102, 103, 107, 140, 188, and 246.

Steel, as the strongest known structural material, compared weight for weight with others, has definite points of superiority over anything else that can be used, the chief objection to it being the difficulty and expense of producing the necessary qualities in the requisite shapes.

Two principal methods of steel-propeller construction are at present in vogue. In one, single sheets of steel (sometimes cast or sheet metal other than steel) are cut to the desired outlines, stamped or bent to the desired forms, and then autogeneously welded to steel hub arms that are placed on the backs, or rarefaction surfaces of the blades. Such propellers are shown in Figures 99 and 104. In the other construction, the blades are each made of two sheets with the arm extended between them in the manner of the wing bars *a a*, in Figures 72, 74, 193, and 194. Such propellers are shown in Figures 98 and 101, and are best assembled by autogeneous welding of the hub arms and the blade edges, though riveting and brazing are employed to some extent. The qualities and physical characteristics of the steels most suitable for use in propellers are discussed in Chapter 11.

Aluminum Alloys as propeller materials have met with some success, when used to the exclusion of other metals as well as when employed simply for blades or blade tips, mounted on steel hub

arms. One of the best of the aluminum alloys is magnalium (see Chapter 11), which is both lighter and stronger than pure aluminum, and which lends itself readily to casting, forging, stamping, and machining. A 4-foot propeller of this material sustained the highest peripheral speed of which the writer knows in this field of engineering. This speed, reached in a laboratory test, was 50,265 feet a minute, involving 4,000 revolutions a minute. Though the propeller stood the test without flying to pieces, the blades warped somewhat out of shape at the higher velocities. This may have been due, however, to poor design. Everything considered, ease of manufacture included, there seems more than a fair prospect that magnalium, cast in iron molds, may prove superior to all other propeller materials, not even excepting wood and steel.

Framing and Fabric—the use of tubular steel frames with fabric coverings—is a combination construction that has been experimented with in propeller design, notably in the case of the monoplane illustrated in Figures 141, 217, and 218. Even with ribs and edgings to stiffen the fabric, there is serious doubt as to the ability of this construction to maintain correct blade surfaces under the distorting influences of the high speeds required, and in all cases of its trial so far it has subsequently been abandoned.

PROPELLER HUBS

Propeller-hub design is a most important detail, since through the hub, necessarily small in size

and close to the shaft, where the tendency to break is greatest, must be transmitted the entire power used for propulsion. With wood propellers the usual design involves a steel shaft through a hole in the wood, with one or two flanges through which bolts are passed to transmit the turning effort, as shown in Figures 100 and 102. A less usual design is that shown in Figure 118, in which a steel hub and hub arms are used, to which the wooden blades are riveted. With propellers entirely of steel electric or autogeneous welding offer simple solutions of hub problems. Similarly, magnalium propellers, cast in one piece, lend themselves readily to ideal hub design in combination with inexpensive production.

A very unusual propeller hub is that shown in Figure 98, and another interesting propeller is that illustrated in Figure 171, in which it is seen that the hub, the hub arms, and the blades are all separately made and subsequently assembled.

A TYPICAL PROPELLER

Having now discussed all the more important and evident considerations that influence propeller design and construction, it is possible to conclude this chapter with a brief description of a typical propeller, which has been found to come very close to realizing the various ideals and requirements of these mechanisms, in so far as these ideals are correct and the requirements understood. This is the propeller illustrated in Figures 108 and 109, which are reproductions of the mechanical draw-

ings and templets, respectively, used in its construction. This propeller, being designed to afford high efficiency with little power and at a low vehicle speed, was made very large in diameter

in proportion to its blade width, and very flat in pitch. It is built up of six layers of $\frac{1}{4}$ -inch wood and two of $\frac{1}{2}$ -inch stock—totaling $2\frac{1}{2}$ inches. The two $\frac{1}{2}$ -inch layers, nearest the front surface, which is the one that appears in the drawing, are maple and spruce, respectively—the first to face the hub and afford a hard surface against which to clamp a flange plate and the second to combine strength with lightness. For the latter reason the first two $\frac{1}{4}$ -inch layers are also spruce, but the third $\frac{1}{4}$ -inch layer is of red birch, which is very resistant to splitting and which, as appears particularly in the side section, extends through the thinner parts of the blades, well towards their tips. Beneath this come two more layers of spruce, to secure extreme lightness in the extreme tip of the blade, and then comes the final layer of maple, chosen partly because of its hardness as a flange backing but chiefly for its quality in holding up in thin and finely carved edges, such as extend clear along the rear edge of the blades and partly around their tips. The advancing edges are the straight ones, as are shown in the end sections, and the



FIGURE 109.
— Templets
for Securing
a Desired
Form in a
Wooden Pro-
peller.

pitch is 18 inches, with a diameter of 6 feet. The heavy lines and figures on the end sections show the corresponding angles at 3-inch intervals from hub to tip. The chord angles, or angles of blade setting (see Page 242), shown by the dotted lines and the light figures in the end sections, are made steeper to calculated extents than the pitch angles, and then a slight further inclination has been empirically allowed in certain of the sections. Close to the hub no attempt is made to secure thrust, the sections here being designed to go through the air with as little resistance as is consistent with sufficient material to afford the necessary strength

The sections of the effective concavities of the blades are approximately parabolic, though not exactly so at right angles to the radii.

The normal speed of rotation is from 1,800 to 2,000 revolutions a minute, and the total weight is about 52 ounces, of which 30 ounces is within six inches of the hub center. This leaves a weight of only 11 ounces for each blade, in each of which fully 4 ounces is between 6 and 12 inches from the center, leaving only 7 ounces in the outer 24 inches of each blade.

The finish is several coats of spar varnish on a priming coat of white shellac, the whole polished to a glass smoothness after being thoroughly dried.

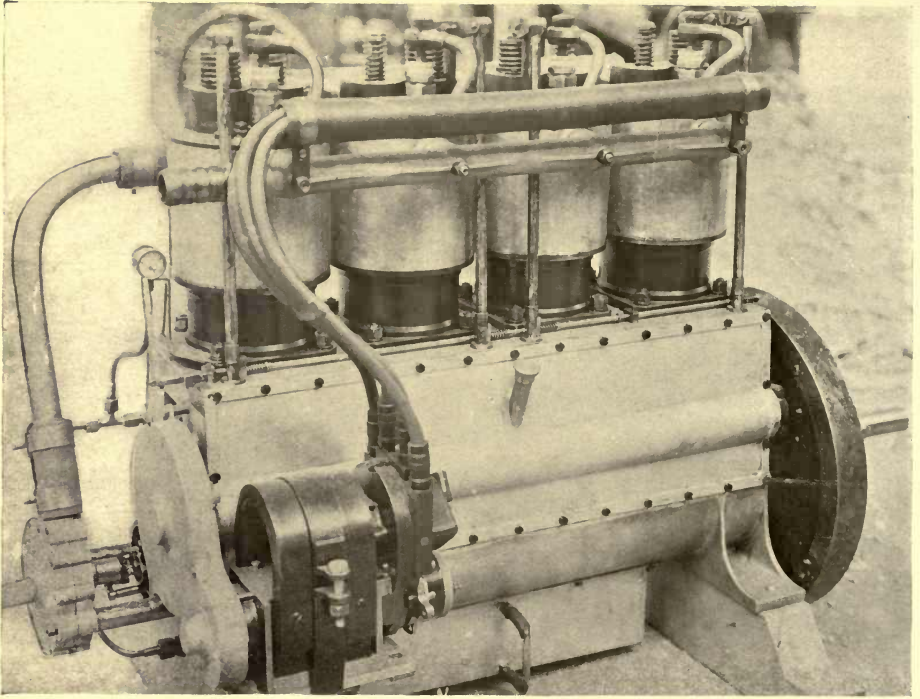

FIGURE 110.—Four-Cylinder Motor of Wright Biplane. Despite the remarkable success made with this motor, gas-engine experts consider it of very crude design, and much behind the best automobile practice. Its considerable weight—190 pounds for 25 horsepower—renders it reasonably reliable.

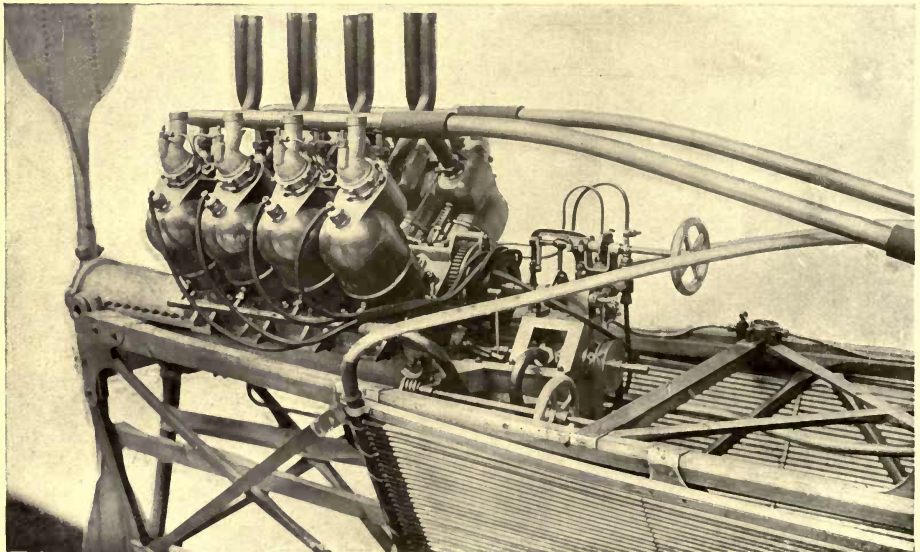

FIGURE 111.—Pump-Fed Antoinette Engine. These wonderful motors, one of which holds the world's record for motor-boat speed, have many aeronautical triumphs to their credit and are in many respects most ingenious and advanced engineering.

CHAPTER SIX

POWER PLANTS

The question of power for the propulsion of various kinds of flying machines, both of the heavier-than-air and lighter-than-air types, is one at the present time of the utmost importance. Indeed, it is a safe assertion that recent developments in aeronautics have been made possible largely through the development of light-weight motors that has been involved in the history of the automobile industry. Equally, it is undoubtedly true that a most serious obstacle in the way of immediate further progress is the lack of motors still lighter, more efficient, and more reliable. Most flights so far made, for example, have been brought to their ends by motor failure, though close to this limitation always has been that of fuel radius, which is directly dependent upon the matters of weight and efficiency.

Of course, it is rather obvious that some of the best flying machines of the present time might be flown with much heavier motors than are used in them—with motors such as have been available for even twenty or thirty years. But it has seemed to be necessary to apply the light-weight motor first as a means of working out the general details of the necessary mechanism, the discovery that

heavier motors could conceivably have been used being therefore an after development.

While considering this question of power, it is to be understood that (as has been suggested on Pages 164 and 169) some of the foremost authorities on aeronautics—men whose theoretical attainments are as indisputable as is their practical knowledge—stoutly contend that it is going to be possible ultimately to achieve without power something akin to the indefinitely-continued soaring flight that is so indubitably established in the case of the larger flying birds. Whether or not these prophets are in any degree carried away by their enthusiasm only time can tell. But certainly it must require some daring to deny, in an age that has seen such upsetting of theories of matter and energy as has been involved in the phenomena of radio-active substances and in other recent investigations, that such flight is possible. It may be, perhaps, that the soaring bird does derive sustentation from upward currents of air, caused by wind friction over surface contours or by ascending streams of heated air, but these hypotheses do not fit in with the views of many trained observers who are almost unanimous in maintaining that soaring is performed by the birds when such assumed conditions do not prevail.*

* In the mountains back of Santa Barbara, California, the writer has witnessed the soaring flight of the turkey buzzard and the great California vulture under conditions differing from any he has heard credited to any other observer, and more than any others leading to the conviction that soaring flight does *not* require either ascending or horizontal currents of air. In the locality referred to it frequently happens that dense fogs drift in from the sea and lay motionless for hours with

For further discussion of this subject, reference should be had to the article quoted from Prof. Montgomery, in Chapter 4.

In any case one thing seems certain—that present machines are exceedingly wasteful of power, losing either through excessive head resistances or inefficient application probably nine-tenths of all that is developed. For example, the latest Wright machine requires one horsepower for the conveyance of each fifty pounds, whereas, according to Langley, the condor carries seventeen pounds with an energy output estimated to be not above $\frac{1}{21}$ horsepower—395 pounds sustained per horsepower.

Obviously, in providing suitable engines, extremely light weight and high efficiency both must be sought, since both are means to greater utilities in the way of increased reserve-carrying capacity—directly by reductions in engine weight and indirectly by reduction in fuel quantity necessary for given distances of travel.

The conditions under which a flying-machine engine must operate differ radically from the conditions applying in ordinary automobile propulsion, being even more severe than those appertaining to racing automobile engines. For, as in the case of the latter, an aeronautical engine must be

so uniform and well-defined an upper level that to an observer who climbs the mountains to above the fog level it appears almost substantial enough to walk out upon. Yet adjacent to the surfaces of these perfectly quiescent seas of fog, which would be visibly stirred by the faintest breath of air, the characteristic soaring flight—with its seemingly effortless gaining of altitude, has been repeatedly observed.

capable of running for hours upon hours at high speed and high power output, in addition to which it must do this with a minimum of attention. These requirements can be met in the case of the commonly-used internal-combustion motor only by the closest attention to such details as lubrication, cooling, carburetion, and ignition. Moreover, any attempt to provide reliability and durability with insufficient bearing sizes and crude lubrication systems, as is often attempted in automobiles by the expedient of building the engine large enough to give much greater power than is normally demanded from it, defeats its own end by the great weight it involves.

The one feature of its use that favors the flying-machine engine is found in the fact that little fluctuation is required in the power output and still less fluctuation is demanded in the rotational speed.

Everything considered, and aside from the matter of weight, the duty of the aeronautical motor is more closely comparable to that of a motor-boat engine than to the engine of an automobile. This comparison, too, affords a much clearer idea of the difficulties to be surmounted, for, while there are many automobile engines that will deliver a horsepower for each ten or fifteen pounds of weight, there are very few that will do so for long-continued runs, especially without much attention. On the other hand, the motor-boat engines, which are capable of delivering full power for hours without attention, weigh from forty to sixty pounds to the horsepower. And yet

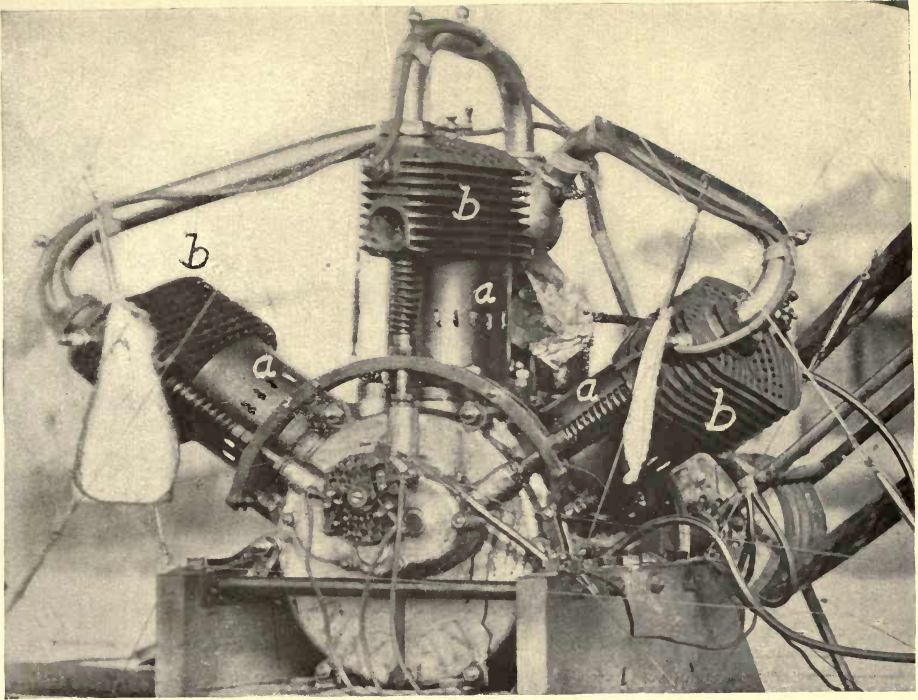

FIGURE 112.—Three-Cylinder, 22-Horsepower Anzani Engine. This engine, which closely resembles an ordinary twin motorcycle motor, with the addition of an extra cylinder, is the one with which Bleriot crossed the English Channel. Cooling is by air passing around the drilled-out fins *b b b*. At *a a a* are auxiliary exhaust ports.

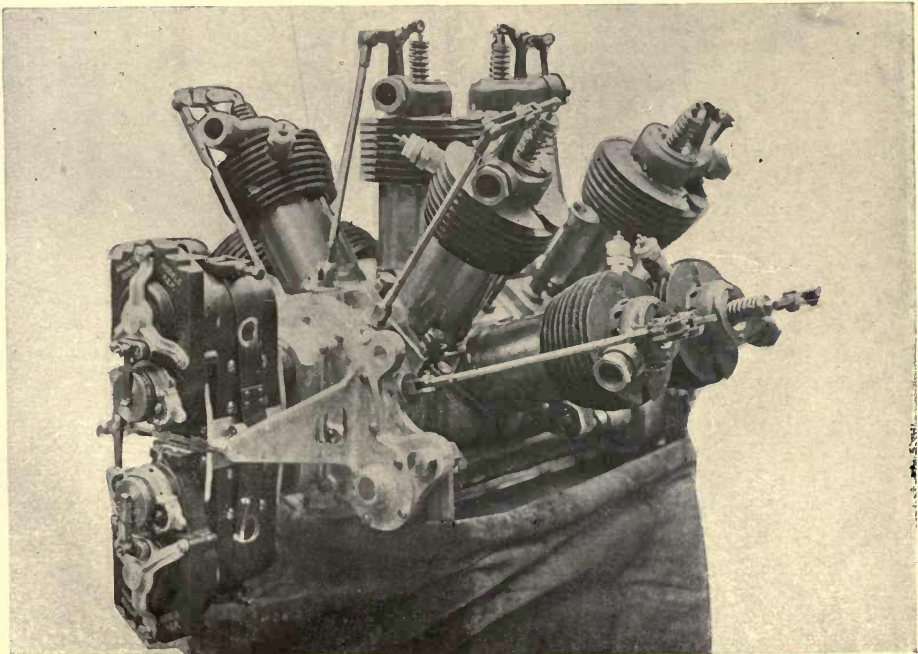

FIGURE 119.—R. E. P. Ten-Cylinder Motor with Concentric Exhaust and Inlet Valves.

it is the capabilities of these engines, rather than those of automobile engines, that constitute the ideal towards which aeronautical motors, weighing from two to seven pounds to the horsepower, must develop.

The quality of the final achievement must be measured by weight, efficiency, and capacity to keep running without care or adjustment as long as fuel and lubricant are supplied.

GASOLINE ENGINES

The gasoline engine in certain of its forms being the lightest prime mover known, and having been developed to high degrees of reliability as an element of motor-boat and automobile mechanism, it is the only one at present finding any considerable amount of favor or offering much promise for future application to aerial vehicles. Aeronautical engines using gasoline as fuel have been built as light as $1\frac{1}{2}$ pounds to the horsepower, and are made of considerable reliability in weights of from $2\frac{1}{2}$ to 7 pounds to the horsepower—the latter figure permitting thoroughly adequate water cooling and including the weight of all necessary adjuncts, such as ignition and carbureter equipment, flywheel, radiator, etc.

MULTICYLINDER DESIGNS

Multicylinder gasoline engines possess various manifest advantages over single-cylinder constructions. In the first place, the more usable four-

cycle motor giving only one power stroke in each four, it is rather necessary to duplicate cylinders to secure smooth and uniform rotation without excessive flywheel provision or crank balancing. Another advantage of multicylinder construction is a little less obvious, this being its effect on weight. To explain, assume the case of a given cylinder capable of developing five horsepower at its maximum speed. This speed, as is well understood by engineers, is only secondarily a matter of rotational speed, it being primarily a matter of the speed of piston reciprocation. Now to increase to, say, twenty horsepower, the cylinder must be doubled in all of its linear dimensions—in both bore and stroke. In accordance with a well-known law of geometry, this cubes the weights and volumes, so would at first appear to cube the power, which would be the case if the speed of rotation were maintained. But, because of the piston speed being the limiting factor, it is necessary in the larger engine to reduce the rotational speed one-half to avoid increasing the piston speed. The consequence is that though the weight is eight times as great as that of the smaller cylinder, the power developed is only four times as great, with the result that the weight per given power is doubled.

On the other hand, if instead of increasing the dimensions of the small original cylinder the policy be adopted of duplicating this small cylinder—ranging four of them, for example, along a single crankcase and crankshaft—then the power is

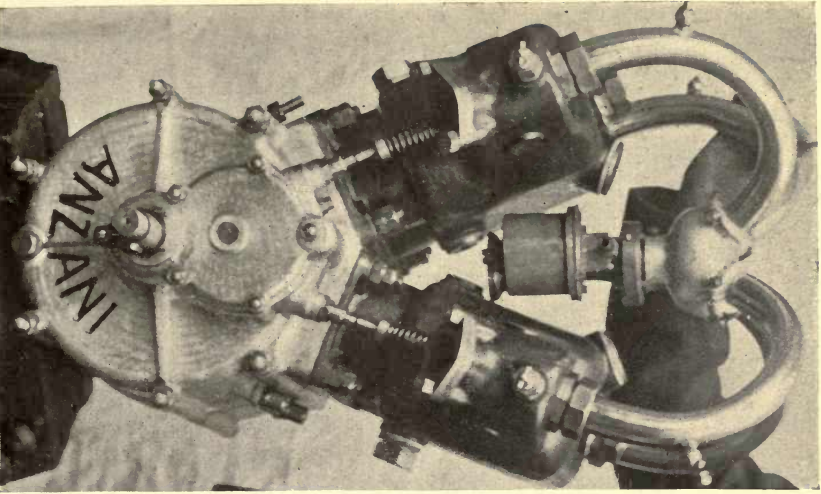

FIGURE 113.—Four-Cylinder—“Double-Twin”—Anzani Motor.

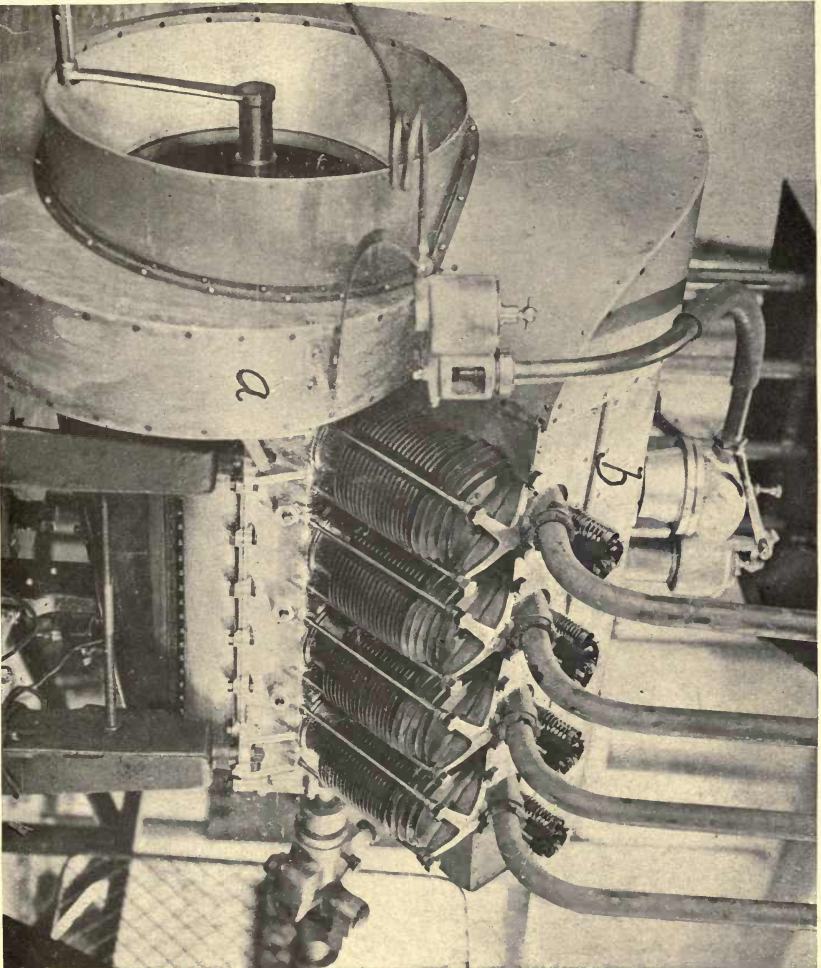

FIGURE 114.—Renault Eight-Cylinder V-Sharp ed Motor. Cooled by air forced through the pipe *b* by the blower *a*.

quadrupled with only a quadrupling in weight, maintaining the original advantageous proportions between weight and power.

Another advantage of multicylinder construction, resulting from its use of small cylinders, is that these are more readily cooled than large, especially if it is undertaken to cool them by air.

Of course, as in the case of everything mechanical, any given construction is rather likely to be a compound of advantages and disadvantages. Among the latter, operating against the multicylinder engine, is the fact that the wall area of the combustion chambers totals a much greater proportion to the total combustion chamber volume than is the case with a single cylinder of the same total capacity, causing greater heat losses to the cylinder walls and consequently increased fuel consumption with reduced efficiency, other things being equal.

CYLINDER ARRANGEMENTS

In engines in which two or more cylinders are used the problem of cylinder arrangement becomes rather a vital one, because of its many bearings upon weight, accessibility, and mechanical and explosion balance. The arrangements found most suited to aeronautical uses are the vertical, V-shaped, opposed, revolving, etc.

Vertical Cylinders, constituting engines of a type common in automobile practice, have been to a considerable extent favored by aeronautic engineers. Characteristic examples of this type of

construction are the four-cylinder motors of the Wright aeroplane, illustrated in Figure 110, and the Panhard motor illustrated in Figure 115. The latter is one of the most remarkable examples of light-weight motor construction in existence, being adequately water-cooled and developing a full 45 horsepower, in spite of the fact that its weight is only 176 pounds.

The chief objection to vertical cylinders, in their usual arrangement in a single line along a crankcase, is that their use inevitably involves longer and heavier crankcases and crankshafts than are required by some other constructions.

Though four cylinders are commonly favored in vertical gasoline engines, with six used to a considerable extent, there are many little-recognized merits in three, five, and seven-cylinder vertical constructions, the two latter of which, particularly, are in better mechanical balance than the six-cylinder (having five and seven throws to their crankshafts, against only three in the six). At the same time sufficient overlap of the successive explosion strokes is provided to afford exceedingly even torque at such high speeds as even the lowest required in aeronautical work. The greatest objection to engines of these odd cylinder numbers is the expense of manufacturing suitable crankshafts.

V-Shaped Engines, like the Antoinette motor illustrated in Figure 111, the Anzani engine illustrated in Figure 113, the Renault engine illustrated in Figure 114, and the Fiat motor illustrated in

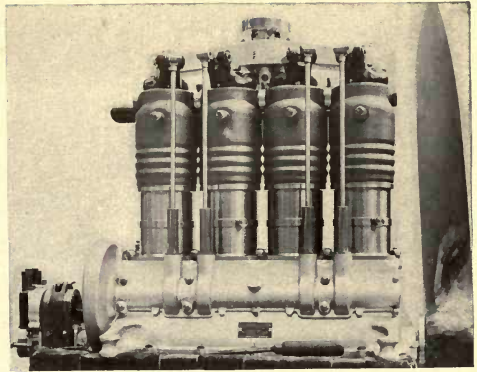
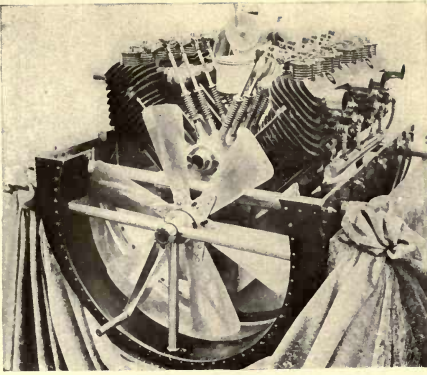

FIGURE 115.—Fiat and Panhard Aeronautical Motors. These are remarkable examples of refined construction, the Fiat developing 50 horsepower with a weight of only 110 pounds, and the Panhard weighing 176 pounds for 45 horsepower.

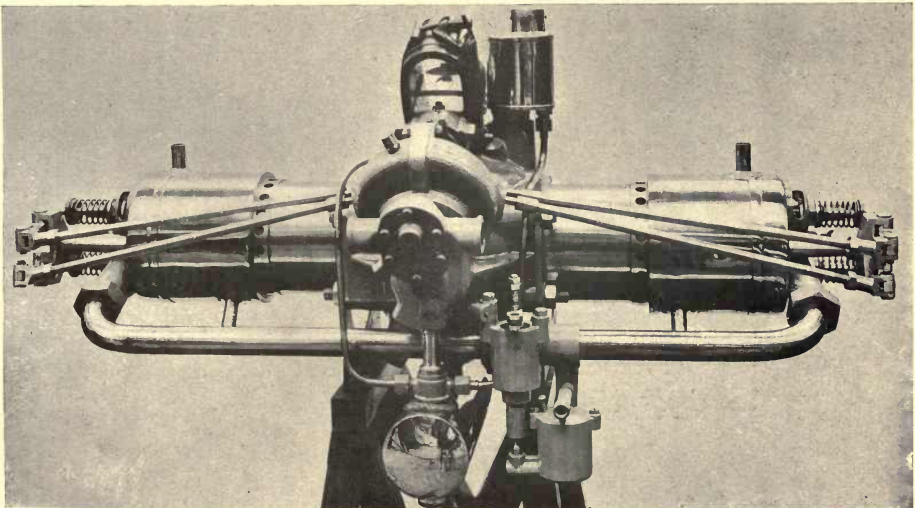
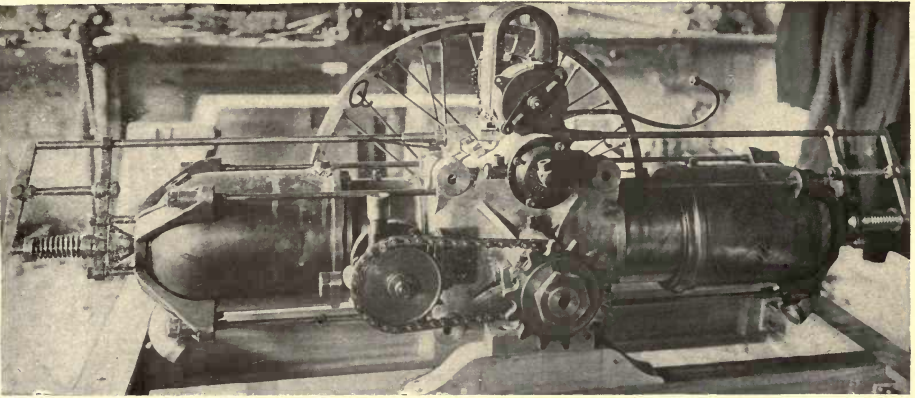

FIGURE 116.—Darracq and Dutheil-Chalmers Aeronautical Motors. The Darracq—in the lower view—is the engine with which Santos-Dumont achieved his recent successful monoplane flights. It weighs 66 pounds and develops 35 horsepower. Of particular interest in the other motor is the flywheel *a*, with steel rim and wire spokes.

Figure 115, permit the working of two cylinders on each throw of the crankshaft—or, briefly, of four-cylinder crankshafts for eight-cylinder engines, etc. With proper angles of cylinder placing and proper numbers of cylinders, engines of this type can be made very light in weight and exceptionally perfect in mechanical and explosion balance.

Twin-cylinder V-shaped engines, which have been much used for motorcycle propulsion, are in no better mechanical balance than single-cylinder engines, but the greater frequency of explosions gives smoother running and evener power output.

The three-cylinder, V-shaped Anzani engine, illustrated in Figure 112, is of special interest as the motor with which Bleriot accomplished his epoch-marking flight across the English channel.

The four-cylinder, water-cooled, V-shaped Anzani engine shown in Figure 113 is of a type with two throws to the crankshaft, with two cylinders on each throw. It has very much less crankcase and crankshaft weight than ordinary four-cylinder engines, is in excellent mechanical balance, and in explosion balance that is irregular only to the rather immaterial extent involved by the slight angular separation of the two cylinder rows.

The ten-cylinder R. E. P. engine illustrated in Figure 119 is an extreme but very successful example of modified V-shaped construction.

Opposed Cylinders, on opposite sides of the crankcase, admit of perfect explosion and mechanical balance with less cylinders than will give anything like an equivalent result in any other type

of construction. In fact, horizontal-opposed motors of the two-cylinder types illustrated in Figure 116 are in better mechanical balance than vertical and V-shaped engines with more cylinders, because the masses of pistons and connecting rods are in balance not only in the opposition of their movements but also in the rates of their opposed movements at any given time, which is not the case with vertical engines, in which the angularity of the connecting rods causes the pistons to travel the upper halves of their strokes at speeds materially higher than those at which the lower halves of the strokes are traversed.

Revolving Cylinders, attached to a crankcase that revolves with them on a stationary crankshaft with one throw, to which all of the connecting rods are attached, have been considered rather freakish but in many respects constitute a most meritorious form of gasoline-engine design. Among the advantages are the securing of a considerable flywheel effect without the added weight of the flywheel, effective air cooling due to the rapid passage of the cylinders through the air, positive closing of the valves without the use of springs (by taking advantage of the centrifugal force), greatly reduced crankcase and crankshaft weight, simplification of the ignition system, operation of all valves by one or two cams, and remarkably smooth and vibrationless running, even at high speeds, due to the fact that there is literally no reciprocation of parts in the absolute sense, the apparent reciprocation between pistons and cylin-

ders being solely a relative reciprocation, since both travel in circular paths, that of the pistons, however, being eccentric by one-half of the stroke length to that of the cylinders. This latter point is made clear at Figure 117, in which *a, b, c, d,* and *e,* are the cylinders, *f, g, h, i,* and *j,* are the pistons and *k, l, m, n,* and *o,* are the connecting rods of a five-cylinder engine of this type. The pistons, it will be noted, revolve in the path *p* around the crankpin *q* as a center, while the cylinders revolve in the path *r* around the crankshaft *s*.

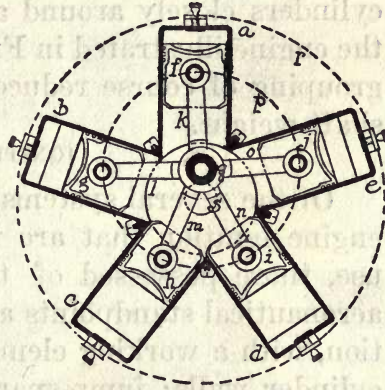

FIGURE 117.—Diagram of Revolving-Cylinder Motor. Note that the cylinders *a b c d e* revolve in the circle *r* around the crankshaft *s*, while the pistons *f g h i j* and the connecting rods *k l m n o* revolve in the circle *p* around the crankpin *q*. Thus there is only a relative reciprocation—none with relation to external objects—in this way almost eliminating vibration.

In the ignition system no separate leads are required for the different spark plugs, each of which wipes past a common contact point as the cylinder passes into firing position. In a similar manner the valve push rods all travel over common non-rotating cams.

One of the most recent and best worked-out designs of revolving-cylinder engines is the seven-cylinder motor shown in Figures 107 and 118. This motor develops 50 horsepower at 1,300 revolutions per minute and weighs only about 175 pounds. Its seven cylinders and the crankcase

ring are machined down from solid steel forgings to as thin as $\frac{1}{16}$ inch.

Miscellaneous Arrangements of cylinders have been devised in great variety, the most noteworthy and successful being various systems of grouping cylinders closely around a small crankcase, as in the engine illustrated in Figures 99 and 119. Such grouping of course reduces crankcase and crankshaft weight.

IGNITION

Of the several systems of internal-combustion-engine ignition that are in more or less general use, those possessed of the most interest from aeronautical standpoints are make-and-break ignition, with a working element passing through the cylinder walls; jump-spark ignition, with one or more coils, external break by a timer or commutator, and sometimes vibrator devices in the external circuit; ignition by heat of compression; hot-tube ignition; and, possibly, catalytic ignition.

Of the foregoing, each has its different merits and demerits, most of which have been pretty well established through long experiment and application in automobile engines.

Make-and-Break Ignition systems when absolutely well designed are most reliable, and undoubtedly tend to make a motor work at its maximum power output and efficiency, but with poor construction or careless adjusting make-and-break ignition is exceedingly prone to a variety of troubles, among which are leakages along the bearing surfaces through the cylinder wall, and

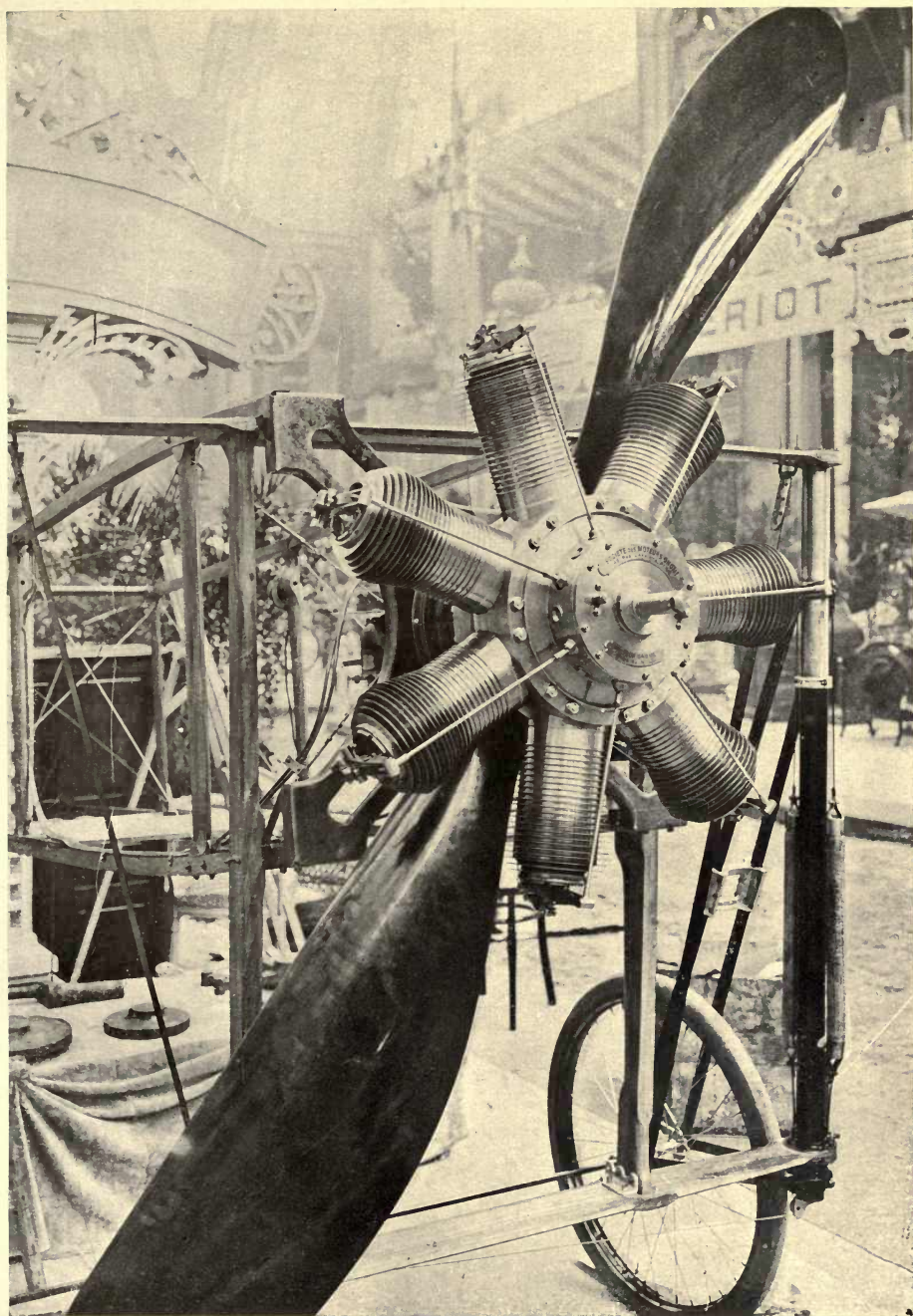

FIGURE 118.—Gnome Revolving-Cylinder Motor. This remarkable engine, which is one of the lightest and most powerful yet built, develops 50 horsepower at 1,200 revolutions a minute. The seven cylinders and the crankcase ring are one piece of metal, being machined down from a heavy casting. The advantage of the revolving-cylinder design is its immunity from vibration, due to the absence of reciprocating parts (the cylinders travel in a circle around the crankshaft and the pistons in a circle around the crankpin) and the elimination of the flywheel. This motor at present holds the distance and duration record of 118 miles in 3 hours. The above picture also affords an excellent view of the Bleriot alighting gear.

(with multicylinder engines) a lack of synchronism in the ignition times in the different cylinders, due to uneven wear of the operating mechanisms. The most-used current source for make-and-break systems is the magneto. An interesting and very successful make-and-break ignition system is illustrated in Figure 120, in which the break within the cylinder is effected magnetically by the magnetic plug.



Figure 120.—
Magnetic Plug.

A diagram of a typical ignition system with mechanical break inside the cylinder is presented in Figure 121.

Jump-Spark Ignition involves no working parts through the cylinder walls and is in its best forms rather more economical in current consumption than make-and-break devices—a point of some value when battery current is depended upon. Furthermore, a jump-spark ignition system may

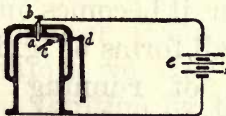

FIGURE 121.—Make-and-Break Ignition. By movement of the arm *d* the point *c* is caused to make and break contact with the point *a*, of the insulated plug *b*, thus producing a spark within the cylinder by current from the battery *e*.

be so designed as to involve very few mechanical parts requiring much attention or adjustment. Its use of very high tension current—approximating 30,000 volts in the secondary circuit—renders it decidedly subject to short circuiting from moisture or undue proximity of wires and other ele-

ments. However, in an aerial vehicle it is easier to guard against short circuiting from moisture than it is in the case of the automobile. Designed with multivibrator coils—one coil for each cylin-

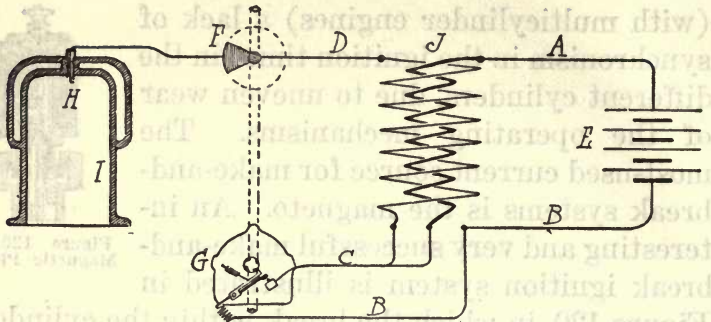

Figure 122.—Mechanical-Break Jump-Spark Ignition System. In this, the current from the battery *e* flows through the circuit *a b*, which is positively broken at suitable intervals by the "snapper" device *g*. This induces a high tension surge in the fine winding of the coil *j*, at the same moment the secondary current in *d c* is distributed to the plug *h* in the cylinder *i* by the distributor *j*, which is mounted on the same shaft bearing the snapper mechanism.

der—it is apt to be heavy, unreliable, uneconomical in current consumption, and subject to serious disturbances of synchronism, but with single-coil systems, and especially in those systems in which

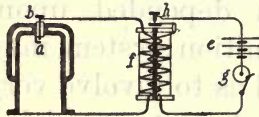

FIGURE 123. — Jump-Spark Ignition. Every time the primary circuit is closed by the timer, or commutator, *g*, current from the battery *c* energizes the coil *f*, and attracts the blade of the trembler *h*. The consequent sudden rupture of the primary circuit induces a current in the secondary circuit of sufficient intensity to make a spark at the gap *a* of the plug *b*.

an exceedingly rapid mechanical-break device is substituted for the vibrator, it becomes one of the best of all forms of ignition, capable of running a multicylinder engine for many hours upon the small quantity of current that is to be had from such small dry cells as are used in pocket flashlights. Larger dry cells and storage batteries are much used in high-tension ignition systems for automobiles, but a magneto is superior to these current sources in convenience and reliability, though probably no magneto system can

be made as light as such a system as that illustrated in Figure 122, in which very small dry cells are used.

A Jump-Spark Ignition System with vibrator coil is illustrated in Figure 123.

Hot-Tube Ignition, such as is illustrated in Figure 124, in which *a* is a hollow tube projecting from the cylinder *b*, and around which is kept playing the flame *c*, is one of the earliest forms of internal-combustion engine ignition, having been extensively used in the first automobile engines. In its best types it is exceedingly reliable, requiring but little fuel to main-



tain the external flame, and involving only the weight of the heating lamps, which can be made very light. The difficulty of timing hot-tube ignition is in a considerable measure met in aeronautical practice by the small need for timing, most aerial vehicles requiring motors working at practically constant speeds.

Ignition by Heat of Compression is a thing of the future rather than of the present, though its possibilities are strikingly suggested in the common "preignition" that constitutes so disconcerting a disability with overheated automobile engines of present types. Engines have, however, been built and run for long periods on ignition by heat of compression, and with careful designing can be made to function very satisfactorily. The Diesel engine—the most efficient internal-combustion engine ever built—works on practically this plan.

FIGURE 124.—Hot-Tube Ignition. Compression of a portion of the charge in the cylinder *b* into the tube through the lamp *a* occasions combustion of the fuel.

The engine illustrated in Figure 125 is made to run with preignition, though in its present forms electric or other ignition is required to start and keep it running until it reaches its normal working temperature. Naturally, ignition by heat of compression is scarcely applicable to mixture-fed engines, working best with fuel-injection engines.

Catalytic Ignition, produced by the action of the hydrocarbon gases of the fuel upon a small particle of platinum black or similar material placed in the cylinder, is a promising suggestion that has hung fire for a number of years in the automobile field. Most alluring in its possibilities, it has so far resisted all serious attempts to reduce it to practice, and the fact that a small particle of platinum black can be brought to a bright, white-hot glow by the action of hydrogen or any hydrocarbon gas is so far more recognized in the building of pocket cigar lighters and automatic gas jets than it is in the design of internal-combustion engines.

COOLING.

The cooling of internal-combustion aeronautical engines is very much of a problem at the present time. Unless a flying-machine engine is designed of a size to afford a considerable excess of power, which unavoidably involves an excess of weight, it must normally and continuously be worked up very close to its maximum capacity, which in turn involves much more severe taxing of the cooling system than is the case with automobile engines, which in ordinary use are worked to their full

capacity only exceptionally. This has made the application of air cooling seem even more difficult than in automobile engineering, in which it is enough of a problem to prevent all but a small minority of manufacturers from attempting it.

Water Cooling therefore being more or less of a present necessity that must be faced in making long runs, the majority of designers plan to provide it in thoroughly serviceable and efficient form, keeping down weights by well-considered application of principles long established rather than by innovations. Light and effective centrifugal pumps are used to produce rapid circulation, often in conjunction with considerable thermosyphon action secured by very tall radiators; waterjackets are made of light sheet metal, preferably applied by autogenous welding; and radiators are of the thinnest possible materials, most carefully put together.

Typical water-cooled engines and cooling systems are the Wright, Panhard, and Antoinette power plants, illustrated in Figures 111, 115, and 190 and 191, respectively. The first of these differs from common practice in that the water is boiled and evaporated into steam in the cylinder jackets, thus requiring a true condenser rather than a radiator for its re-use, and permitting the whole motor apparatus to function at a temperature materially higher than the objectionably low temperature of ordinary water-cooled engines. The Wright engine is kept cool by the tall tubular radiator *a*, Figures 190 and 191, the water being circulated by the centrifugal pump *b*.

Air Cooling has the merit over water cooling that it reduces weight, increases reliability, and simplifies construction, the only bar to its universal use being the question of its effectiveness. In a flying machine, too, except in the case of the

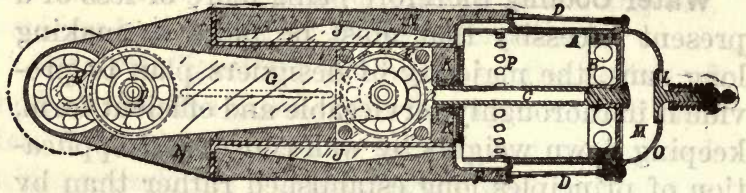

FIGURE 125.—A Light-Weight Aeronautical Motor. In the functioning of this engine, which is of the four-cycle, internal-combustion type, pure air is inspired through the poppet valve *L*, during the suction stroke, directly from the outer atmosphere. At the end of the suction stroke, air compressed beneath the piston *B* is scavenged into the cylinder *A* by the uncovering of the ports *P*, the valve *L* remaining open. During the compression stroke the combined volumes of air continue to be scavenged out through *L* until the piston has made from one-fourth to one-third of its travel, at which point, *L* closing, compression begins and is carried to a very high point in the comparatively small clearance *M*. Carburetion is by fuel injected directly into the cylinder near the end of this stroke, and ignition immediately follows, being effected by any suitable means. Also, during the compression stroke, air is inspired beneath the piston through the leather clack valve *KK*. Well before the end of the explosion stroke, *L* is opened by the cam mechanism to serve now as an exhaust valve, and the burned gases are discharged through it directly into the atmosphere, being aided in their exit by another blast of pure air through the ports *P* when these are uncovered by the piston. Then, throughout the exhaust stroke, *L* remains open. The cylinder *A* is a very thin cast-iron shell, with a reinforcing wrapping of piano wire, and it is clamped between the steel head *O* and the base *F* by a circle of bicycle spokes *DD*. The light sheet-steel connecting rod *G* is built up by autogenous welding and is on annular ball bearings at the crosshead *E* and the crankpin *I*, of the crankshaft *H*. The disk piston *B* is built up by autogenous welding of a steel center and a cast-iron bearing portion, and is connected by the hollow steel piston rod *C* to *E*, which runs in the guides *JJ* welded to the frame *NN* and the base *F*. The internal scavenging affords high efficiency and thorough cooling, but the engine is, of course, very noisy because of the direct discharge of the exhaust.

dirigible balloons, there always is a good current of air available (for either air or water cooling) without the necessity for any fan, the impossibility of a slow rate of travel of the vehicle assuring this. Nevertheless, to enhance the effect, in some of the most successful air-cooled aeronautic engines there are employed blower schemes to induce powerful

air currents of great volume, as in the case of the eight-cylinder, V-shaped, air-cooled Renault engine illustrated in Figures 98 and 114.

A principle that is greater in future promise than in present application is that of internal air cooling—cooling the cylinders of the engine by the scavenging action of considerable quantities of air, in excess of those required for the charge volumes, passed through the interiors of the cylinders in the course of their functioning. Internal air cooling is most successfully applied in conjunction with fuel injection as a means of carbureting the charges.

An internally-cooled, fuel-injection, four-cycle engine patented by the writer is shown in a single-cylinder construction adapted to aeronautical uses in Figure 125.

CARBURETION

The carburetion of the liquid fuel, usually gasoline, necessary for the common forms of aeronautical engines is very much of a problem. The ordinary carbureter is in most respects a non-positive mechanism, in consequence of which its functioning is attended with many uncertainties even in its application to automobiles. These uncertainties become many times more serious in application to aeronautics because of the difficulty of effecting adjustment while at the same time keeping the machine in operation.

Carbureters for flying-machine engines are closely similar to those found best for automobile engines.

In the automobile field the general type of carbureter most used is that illustrated in Figure 126, in which the flow of fuel from the main fuel tank is controlled by the float *a* operating on the float valve *b*, the fuel entering the float chamber *c*



FIGURE 126. — Carbureter. Fuel from the tank flows through the pipe *d* until the float chamber *c* is filled to a level determined by the rising of the float *a*, which closes the valve *b*. From *c* extends a pipe terminating in the atomizing nozzle *e*, which is located in the pipe *f*, through which air is inspired in the direction of the arrows by the suction of the engine. This suction causes gasoline to spray from *e* in quantities proportionate to the force of the suction, except that at very high suction the valve *g* opens and by thus admitting air between *c* and the engine prevents the fuel from becoming too rich at high engine speeds. The butterfly valve at *h* is the throttle.

through the pipe *d*. From the float chamber *c* the fuel is drawn by way of the atomizing nozzle *e* into a current of air passing through the pipe *f*, this current being induced by the suction within the cylinders.

Obviously, to secure uniformly-proportioned fuel it is necessary that

the fuel level in the atomizing nozzle be maintained fairly constant. Also, for variable-speed engines, it is desirable that the carbureter action be such as not to derange the mixture materially through variation in the suction from different speeds. With no means of compensation, at higher engine speeds—and consequent higher suction—the air flowing through *f* tends to attenuate, or “wiredraw”, while the quantity of fuel passing through the atomizing nozzle increases, thus furnishing a fuel altogether too rich for best results. To offset this effect it is customary to provide means of admitting extra air into *f*, as through the valve *g*, which automatically opens wider and wider as the suction in-

creases. Other means of arriving at a similar result are admission of air through positively-controlled valves interconnected with the usual butterfly throttle placed as at *h*, or by devices that reduce the orifice of the atomizing nozzle *e*.

In many carbureters designed primarily for automobile use, the floats and float chambers are made concentric in form, surrounding the atomizing nozzle, the purpose of this being to maintain a constant level of fuel in the atomizing nozzle regardless of fore-and-aft or lateral tilting of the vehicle. In a flying machine this seems hardly necessary because longitudinal tilting never under normal conditions can exceed the comparatively flat angles of gliding or ascending, while lateral tilting is compensated for by the centrifugal force set up in turning, which acts upon the liquid within the float chamber as well as upon every other element of the machine.

Because of the objections to carbureters, the use of positive fuel injection, either into the intake piping or directly into the cylinders, is a practise favored by several foremost designers. Fuel injection, besides being positive, admits of much closer regulation than is possible with a carbureter, and because the injection can be timed permits of high compressions without preignition, the fuel injection being delayed until ignition is wanted.

The chief difficulty in the way of general employment of fuel injection is that of commutating the fuel to the different cylinders without the objectionable scheme of employing a plurality of

pumps, one for each cylinder, which besides adding complication will scarcely admit of such adjustment as to give exactly uniform results in all the cylinders—a difficulty, however, which is no greater than that of equalizing the intake manifold from a carbureter so as to produce uniform feeding. In fact, there is no means of carburetion in existence today for automobile or similar liquid-fuel engines that will insure a power output from a plurality of cylinders varying less than from five to ten percent from cylinder to cylinder, as disclosed directly on the face of manograph diagrams.

Fuel Pumps of the most satisfactory forms are exceedingly simple, involving little more than a brass pump block, chambered out to receive a steel plunger and provided with ball check valves and the necessary pipe connections.

An ordinary stuffing box, packed with oil and cotton wicking and operated in an oil bath is enough to prevent leakage even with the use of a fuel such as gasoline, which is a solvent for all common lubricants. Soft soap, however, is in some respects preferable as a packing, and affords very good results.

The proper fitting of the very small valves required, so that they will seat positively and tightly, takes very close work, but is quite within the abilities of any competent machinist.

All valves in a fuel-injection system should be placed vertically, and extreme care must be exercised in the arrangement of piping and in the design of all cavities to prevent air locks, the pres-

ence of which will cause most obscure and difficult troubles.

A typical fuel pump, which has been used without change for twelve years on the Mietz and Weiss

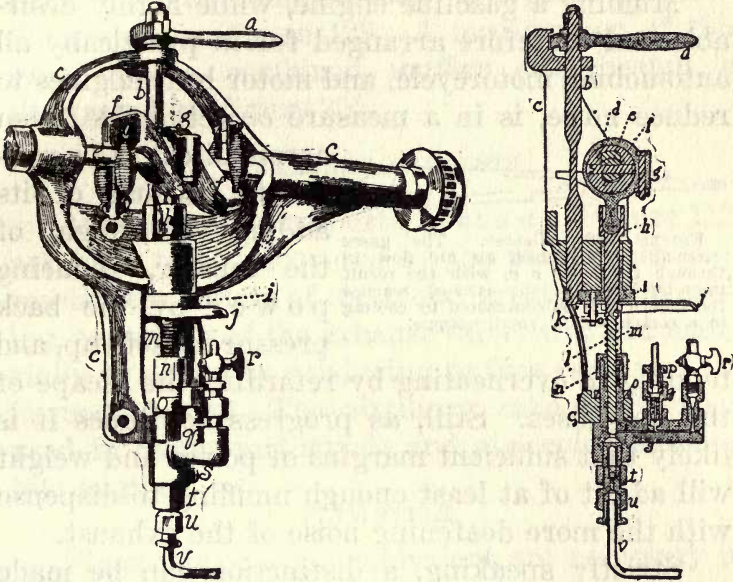

FIGURE 127.—Mietz and Weiss Fuel Pump. The gasoline comes from the tank through the pipe *v*, attached by the coupling *u*, and enters the cavity in the pump block *s* through the valve *t*. Its flow is caused by the plunger *l*, driven by the eccentric *d* through the strap *g*, and retracted by the spring *m*, and it passes out through the valve *q* and the pipe *p* to the engine cylinder. The stroke of *l* is regulated by the regulator handle *a*, mounted on the regulating shaft *b*, which forces down the plunger-guide sleeve *i* and thus retracts *l* from the eccentric. Priming is effected by pushing down on the pump handle *j*, which is forced up after each stroke by the spring *k*. At *r* is an air cock, to clear the system of possible air locks. A governor weight *f* on the shaft *e* is used to control the speed automatically, the whole running in the frame *c*.

two-cycle kerosene stationary engines, in one, two, three, and four-cylinder units, is illustrated in Figure 127.

The best steels for making fuel-pump plungers and other steel pump parts are the high nickel steels much employed in automobile-engine valve

construction, and containing from 25% to 35% nickel, which has the effect of making them almost non-corrosive.

MUFFLING

Muffling a gasoline engine, while highly desirable and therefore arranged for in practically all automobile, motorcycle, and motor boat engines to reduce noise, is in a measure objectionable from



FIGURE 128.—Silencer. The gases entering at *a* induce an air flow in through the holes *c c*, with the result that by the time the exhaust reaches the mouth *b* it is contracted by cooling to a comparatively small volume.

aeronautical stand-
points because of its
adding the weight of
the muffler, reducing
power by the back
pressure it sets up, and
tending to overheating by retarding the escape of
the hot gases. Still, as progress continues it is
likely that sufficient margins of power and weight
will admit of at least enough muffling to dispense
with the more deafening noise of the exhaust.

Strictly speaking, a distinction can be made between mufflers and silencers, the former reducing noise by choking back and retarding the exit of the gases by means of baffle plates, projections, and chambered constructions, while silencers reduce noise not so much by retarding the exhaust as they do by cooling and thus shrinking the gases. The latter plan is by all means the most advantageous in designing for minimums of weight and back pressure.



FIGURE 129.—Muffler. The gases entering at *a* flow back and forth as indicated by the arrows until they issue from the vent *b*.

The lightest form of silencer is a long, fun-

nel-shaped tube, such as is illustrated in Figure 128, in which *a* is the exhaust pipe from the engine, *b* is the mouth of the silencer, and *c c* are openings into which air is drawn by the blast at *d*, this induced air assisting cooling. A typical muffler is illustrated in Figure 129. A modification of this type into a combined muffler and heater is illustrated in Figure 255.

AUXILIARY EXHAUSTS

Auxiliary exhaust ports, as at *a a a*, Figure 112, arranged to be uncovered by the piston just as it reaches the bottom of its stroke, greatly assist cooling, especially of the exhaust valve, and add materially to power by conducing to free escape of the burned charge. The auxiliary exhaust is much used in racing-motorcycle and air-cooled automobile engines.

FLYWHEELS

Flywheels or some equivalent are necessary in all forms of internal-combustion engines to produce uniform rotation and torque from the intermittent impulses in the different cylinders. Consequently it is a general rule that the fewer the cylinders the greater the flywheel effect required.

Since the momentum of a flywheel is a function not only of its mass, but also of the velocity at which this mass moves, increased flywheel effect can be secured either by adding more material or by increasing size. The latter when permissible is much the more advantageous plan, because, for example, doubling the diameter of a flywheel—sim-

ply redistributing the material—quadruples the effect, since the resulting doubling of the circumference doubles peripheral speed while at the same time the rim is removed to twice the distance from the center. On the other hand, simply adding laterally to a flywheel another of similar size and weight is doubling of the weight with only doubling of the flywheel effect.

From these considerations it will be understood that the larger a flywheel the better, the only limits being those set up by consideration of space available and the matter of interference with the details of surrounding mechanism.

It being settled as desirable that as much as possible of the weight of a flywheel be concentrated in its rim, where the speed of movement is highest, the tendency in designing flywheels for aeronautical engines is to reduce the centers of these wheels to their lowest terms.

A very interesting design is that illustrated at *a*, Figure 116, in which the rim is seen to be of turned steel, held to its hub by such an arrangement of stout wire spokes as is used in an ordinary bicycle wheel.

As is explained in a previous paragraph (see Page 282), the use of revolving cylinders in an engine eliminates the necessity for a flywheel. Another road to the elimination of the flywheel, with its undesirable added weight, is the use of propellers as a substitute for it—a perfectly feasible and very usual plan when the design is such that the propeller or propellers can be mounted

directly on a prolongation of the engine crankshaft. It will be noted that this construction is employed in several of the aeroplanes illustrated herein.

STEAM ENGINES

The steam engine, though not extensively applied either to automobile propulsion or to aeronautics, nevertheless has disclosed very definite merits in so far as it has been applied. Not the least of the advantages of a steam power plant is the ability to use—in one and the same plant—a great variety of common fuels, readily obtainable anywhere.

In the matter of weight, one of the lightest engines of any kind ever built was that exhibited by Stringfellow at the British Aeronautical Exhibition in 1868 (see Page 157), this engine developing one horsepower for each thirteen pounds of weight.

In 1892 Laurence Hargrave built a steam engine weighing only 5 pounds, 11 ounces, with boiler, and showed how the boiler could be lightened enough to bring the weight down to only 3 pounds, 14 ounces without reducing the output of .653 horsepower. This figures less than 6 pounds per horsepower (see Page 122).

A larger light engine was that designed by Clement Ader, for use in his early aeroplane experiments (see Page 134). This engine, which was in duplicate—one for each of the two propellers—had two high and two low-pressure cylinders in each unit, placed horizontally, and with the bores

2.56 inches and 3.937 inches and the stroke 3.937 inches. The boiler was of the multitubular type, alcohol-fired, and delivered steam at a pressure of 140 pounds to the square inch. The two motors together, without boiler, weighed slightly over 92½ pounds and ran at 600 revolutions a minute.

A particularly remarkable engine was that designed by Hiram Maxim and used in his experiments in 1894. This engine, which was in the machine illustrated in Figures 235 and 236, weighed with the boiler but without water about 1,800 pounds, and developed 363 horsepower—less than five pounds to the horsepower.

Another very light aeronautical engine was the steam engine used by Professor Langley in his successful model flying machine, which flew over the Potomac River in 1896 (see Page 136). This power plant, with a total weight of 8 pounds, developed 1½ horsepower.

In the matter of reliability, it is a well known fact that several automobiles with steam power plants, besides being substantially as light as the best gasoline cars of similar capacity are well above the average in reliability and durability, though it often is charged against them that they require unusually expert care and handling, a requirement that for the time being is not an especial objection in the case of the flying machine.

A steam engine recently designed in France for application to an aeroplane is that illustrated in Figure 130, the boiler for supplying it with steam being shown in Figure 132.

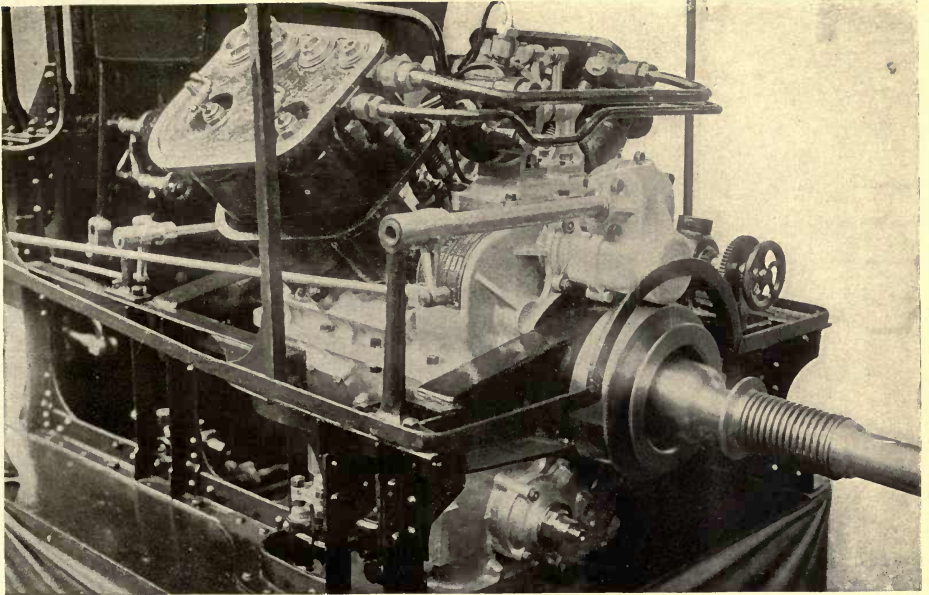

FIGURE 130.—Steam Engine for Aeronautical Use. This engine, which is of French design, follows gasoline-engine practice in the V-placing of the cylinders and the use of poppet valves. It is designed for use with the boiler shown below.

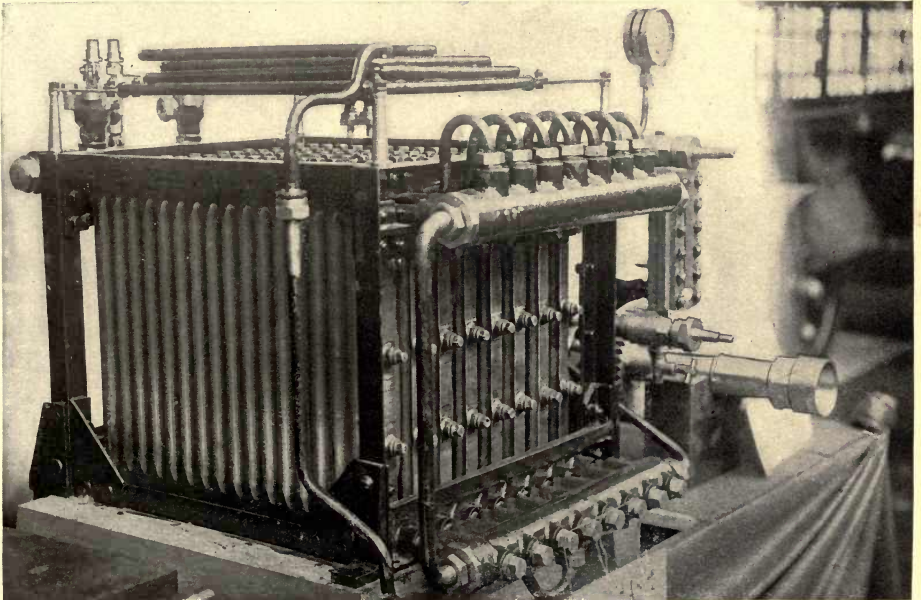

FIGURE 132.—Water-Tube Boiler for Aeronautical Use. This boiler closely resembles the steam "generators" used in steam automobiles. Its light weight, efficiency, capacity for the rapid production of steam at extremely high pressure, and its freedom from scaling and corrosion are the chief merits of this construction.

AVAILABLE TYPES

Of the different types of steam engines those most available for aeronautical service are, unfortunately, in most cases the least efficient—a difficulty that applies in practically similar degree to internal-combustion engines. Thus the elaborate compound, triple, and quadruple expansion types, by which a maximum of the available energy of the fuel is transformed into useful work, involve too great a weight of machinery to permit their use. Instead of these the less-efficient, light, high-speed and high-pressure single-acting and double-acting engines are found best, though the amount of compounding that has been found permissible in automobile engines is perhaps worth securing.

The steam turbine would appear on first consideration to be the best possible type of motor for a flying machine, its direct rotary movement permitting a minimum loss in the transmission of the power to the evenly-revolving propellers, but it is an unfortunate fact that at present steam turbines in any but the largest size are woefully inefficient. With future developments in this department of steam engineering, together with probable decrease in the size of flying machines, it seems more than likely that the moderate size steam turbine may here come into its own.

BOILERS

Steam boilers are of two principal types—fire-tube and water-tube. Typical of the former is the common flue boiler illustrated in Figure 131, in

which *a a* are copper tubes headed into the steel crown sheets *b* and *c*, which are further connected by the steel shell *d*, wrapped with piano wire to afford the necessary strength with extreme light-



FIGURE 131. — Flue Boiler. This type of boiler consist of the crown sheets *b c*, connected by the tubes *a a a*, through which the fire is forced. The shell *d* is often wrapped with piano wire.

ness. This type of boiler has been much used in steam automobiles and is very light and efficient, the hot gases from the fire beneath it passing through the flues and thus coming into contact with very extensive surfaces on the other side of which is the water to be heated.

The flash "generator", which has been found most successful in automobile practise, consists fundamentally of one or more long steel tubes more or less closely coiled through the fire, and provided with means for pumping water into one end, to issue as steam at the other. A boiler of this type naturally must be made to stand a high temperature without injury, regardless of whether or not it contains water, the water being pumped in only as steam is required and being "flashed" into steam as it comes in contact with the hot surfaces. The best examples of this type of boiler are remarkably light and efficient, will withstand working pressures up to 1,200 pounds to the square inch, and are immune from the explosion possibilities that always exist in connection with other types, especially if very high pressures are employed.

A flash generator designed to supply steam for

the aeronautical engine shown in Figure 130 is illustrated in Figure 132.

BURNERS

Burners for steam power plants vary from the common automobile type gasoline burner to the numerous types of grates and fireboxes required for coal, wood, and other heavy fuels. For aeronautical steam power plants there would appear to be the widest field for a combination firebox, capable of being readily arranged to consume either liquid or solid fuel. This should not involve any serious weight or complication, while the almost unvarying power demand makes possible utilization of solid fuels with much less attention than would be necessary with an automobile.

FUELS

Of the fuels available for steam power plants, the most easily fed and controlled are the liquid fuels, such as gasoline, kerosene, benzene, benzine, alcohol, and crude petroleum.

Of the solid fuels there are coal, coke, briquettes (of coal dust, pitch, and other materials), charcoal, and wood. Coke and charcoal afford very clean and hot fires with little or no smoke. Wood has the merit of universal availability, so that a machine utilizing it could find fuel by descending in almost any locality. Something of the same sort is true in lesser degree of coal. The weights, bulks, and heating value of the more common liquid and solid fuels are given in the following table:

COMPARISON OF FUELS

FUEL	WEIGHT	CALORIFIC VALUE
	(percubicft.orgallon)	(In British Thermal Units per Pound)
Gasoline.....	6.16 pounds	18000—21900
Denatured Alcohol	8.10 pounds	14172
Kerosene	6.80 pounds	22000
Distillate.....	7.30 pounds	18000
Crude Petroleum.....	7.35 pounds	20500
*Liquefied Acetylene.....	4.00 pounds	18260
Anthracite Coal.....	83 to 110 pounds	15225
Bituminous Coal.....	80 to 89 pounds	15370
Coke.....	30 to 40 pounds	13620
Charcoal.....	10 to 12 pounds	13500
Dry Hardwood.....	30 to 60 pounds	7000

* Acetylene liquefied at 68° F. under 597 pounds to the square inch. In this form it is very dangerous unless its use is attended by proper precautions, but it is nevertheless considered by some engineers to possess important possibilities in applications to light-weight, high-power engines.

Of even more importance than its theoretical calorific value is the efficiency with which a fuel can be utilized in a practical engine. Thus alcohol, with a comparatively low thermal value, can be utilized with a high thermal efficiency, in internal-combustion engines giving fully as much power as equivalent weights of gasoline.

ELECTRICITY

Though electrical power for the propulsion of aerial vehicles has too many shortcomings to admit of its present practical utilization, it undoubtedly holds out a few promises that, though vague, make it worthy of some consideration.

ELECTRIC MOTORS

Electric motors, while ideal for aeronautical application to the extent that they permit great speeds and develop their power through directly-rotating elements, are decidedly heavy—even without considering the question of current source—as

compared with most other prime movers. The lightest and highest speed electric motor ever built was that of M. G. Trouvé, experimented with in Paris in 1887. This motor had aluminum circuits and weighed only 3.17 ounces, but developed $\frac{1}{8}$ horsepower—at the rate of 7.53 pounds to the horsepower, a figure that there does not seem to be any particular prospect of reducing in any practical construction. The electric motor used in the Tissandier dirigibles, with which the Tissandier brothers experimented in France in 1884 (see Page 81), weighed 121 pounds and developed a maximum of only $1\frac{1}{2}$ horsepower. This was a direct-current-motor. Undoubtedly alternating-current motors can be built considerably lighter, though no serious attempts, founded upon the present state of electrical knowledge, have been made or are likely to be made to produce them for aeronautical uses.

CURRENT SOURCES

The electric motor, unlike the gasoline engine, is not a prime mover, since it requires a supply of electric current from some source external to itself to keep it going. In its application to the propulsion of street-railway cars this current is developed in stationary power plants and transmitted to the moving vehicles by sliding or rolling contacts against wires or other conductors. In electric automobiles current is supplied by storage batteries carried in the machine. Obviously the first of these systems is not applicable in any practical way to aerial travel.

Storage Batteries, or accumulators, do not really store electric current, but produce it by chemical reactions, exactly as is the case with primary batteries. They differ from these, however, in that the chemical elements involved in their operation can be electrolytically recomposed by a passage of electric current through the cells after each period of discharge. This process is termed charging.

The best modern automobile storage batteries of the lead-plate types are capable of delivering a current of 80 ampere hours, at about 2 volts, from each five pounds of weight. Multiplying the amperes by the volts and dividing the watts thus reached by 746 (746 watts being the electrical equivalent of a horsepower) it is found that about 24 pounds of battery are required to maintain an output of one horsepower for one hour, against a fuel consumption of about one-half a pound per horsepower hour in the best gasoline engines.

Much effort has been expended in attempts to produce storage cells much lighter for a given capacity than those now in use, and, though these cells in some cases give better results than the above figures indicate, these improved results in the matter of capacity per unit of weight usually are attained only by great sacrifices of durability.

By many engineers the most promising possibility in the way of lighter weight storage batteries is considered to be the development of the so-called alkaline type of storage cell, of which the Edison and Jungmann cells are today the prin-

cipal exponents. In these cells the elements are metallic nickel and iron, and nickel and cobalt oxide.

Of lead storage batteries, there are two principal types—the formed and the pasted. In the former the oxide of lead that constitutes the active material is formed on the surfaces of the electrode by electro-chemical processes of charging and recharging, while in the latter the plates are cast lead grids, made in a great variety of forms, and with the interstices filled with oxide of lead compressed in place under high pressure.

Primary Batteries, though not totally unavailable as a source of current, are by no means exceptionally light in any forms now known, besides which they are enormously expensive to operate. The plunge-bichromate type, in which the electrolyte is bichromate of potash in which are immersed positive and negative electrodes of zinc and carbon, respectively, was that used by the Tissandiers (see Page 81), the total weight of their battery being 496 pounds. While it is perfectly conceivable that lighter primary batteries may be produced it is to be regarded as certain that they will be hopelessly expensive, while as in the case of the storage battery they will have to be so very much lighter before they can find any considerable utility in application to aeronautics that the prospect of their appearance seems very remote.

Thermopiles, by which electricity is produced directly from heat, are today interesting devices of the physical laboratory rather than factors in the

world's engineering activities. The laws of thermopile action are only imperfectly understood, but, in a general way, it can be explained that the typical apparatus of this kind consists of assemblages of numerous dissimilar metal bars or parts, joined together by their ends in series. When the points of juncture are heated the result is that an electric current, very small in proportion to the weight of the apparatus and the quantity of heat required, is produced. Moreover, the joints tend to come apart with continued use and it is found rather difficult to localize the heat as it should be for the best results. The metals at present found to give the most efficient results are bismuth and antimony in combination. It is a recognized remote possibility, however, that development in thermopiles may some day revolutionize present methods of power development. Possibly the road to such development will be found in the use of refractory metals heretofore little tried for this purpose, such as copper and iron, or metals of the platinum group, put together by electric or autogenous welding, and filamented and air-cooled in their middle portions to maintain localization of the heat.

MISCELLANEOUS

Besides the various more-or-less well-established or well-investigated power sources already considered, there are a few more freakish and less serious possibilities that perhaps call for cursory mention.

COMPRESSED AIR

Compressed air, or liquid air, stored under high pressure in steel cylinders, has been used with some success in model flying machines—particularly in those of Hargrave (see Page 122)—experimental automobiles, mine locomotives, etc., the power being developed from it through practically a type of small steam engine, but the advantages of this system are most manifest in almost any direction but that of light weight, so its application to practical aerial navigation is not likely.

CARBONIC ACID

Carbonic acid gas can be used in much the same manner as compressed air, in comparison with which it has minor merits and still more serious shortcomings.

VAPOR MOTORS

Vapor motors—practically small steam power plants in which some more volatile liquid than water is used to produce the steam, the liquid being recondensed and used over and over—have long offered an alluring field for experiment, besides which they found rather extensive application to motorboats and launches before the days of gasoline engines.

The most successful type of vapor motor is the common naphtha boat engine. Next to this come various types working with acetone, alcohol, etc., few of which have run outside of experimental workshops, and all of which are heavy and inefficient.

SPRING MOTORS

Spring motors, though out of the question for the propulsion of man-carrying aerial vehicles, have served and continue to serve a considerable purpose in experimenting with models. A twisted rubber band, employed as suggested at *a*, Figure 29, can be made to afford a surprising amount of energy within a very small weight.

Steel springs are from most standpoints less practical than rubber, but they, too, have found use in models.

A bent wood, whalebone, or bamboo splint, or a flat steel spring, *a*, furnishes the power in the well-known form of toy or model helicopter illustrated in Figure 28.

ROCKET SCHEMES

Rocket schemes, in which propulsion and ascension are expected to be secured from the reaction of sky-rocket-like discharges of gas from explosion chambers, have been a recurring feature of the theoretical phase of aeronautical development for many years. All such schemes seem condemned by the fact that no known explosive contains anything like as many heat units per pound as a great variety of true fuels, their characteristic feature being not a capacity for great power output, but simply the property of expending their entire energy content in exceedingly brief spaces of time.

TANKS

The tanks for transporting the fuel, water, and oil necessary to the operation of the various prac-

tical types of aeronautical power plants, must fulfill a variety of conditions, chief among which are capacity, strength, light weight, immunity from corrosion, and—in many cases—a form favorable to the reduction of head resistance. For any given capacity and strength, with a minimum weight, spherical tanks are best. Immunity from corrosion is generally provided by the use of copper or brass, but steel is enough stronger to warrant its use, protected by interior and exterior plating with other metal. The form most favorable to progress through the air with a minimum resistance is the elongated pear-like form, blunt-end foremost, next to which come the great variety of elongated cylinders and other possible constructions in which circular sections are a feature. Undue elongation of such forms adds greatly to weight and so reduces carrying capacity as to be inexpedient unless in some special case such as that of the dirigible *nacelle*, illustrated in Figures 19 and 20, in which the tubular tank also constitutes a stiffening member in the framing.

The liquid fuel is most reliably fed to the motor by gravity, but pressure or pump feed are both employed, and can be made very satisfactory with sound designing, as has been well established in various constructions now widely recognized as good practice in automobile engineering.

A point of particular importance when large quantities of fuel for long flights are carried, is the location of the tank at the center of gravity of the whole machine, so its gradual emptying will

not disturb the balance. This point has been very carefully observed in the design of all successful modern aeroplanes, including the Wright, Bleriot, Antoinette, and other machines. The same point applies with equal force to the location of tanks for water and oil, and the seating accommodations for passengers.

A point of particular importance when large quantities of fuel for long flights are carried, is the location of the tank at the center of gravity of the whole machine, so its gradual emptying will

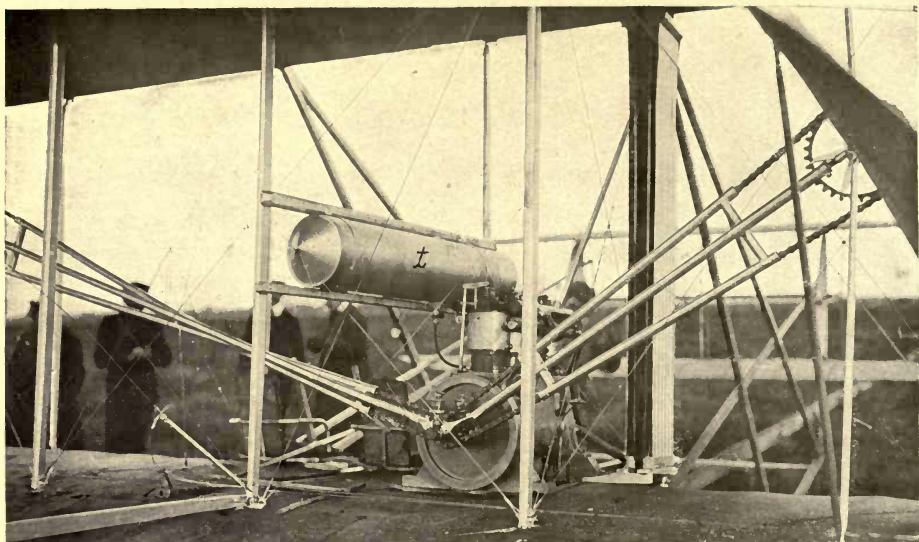

FIGURE 139.—Chain Transmission of Wright Biplane. Note the crossing of tubular chain-guides at the left—also the placing of the fuel tank *t* at the center of gravity.

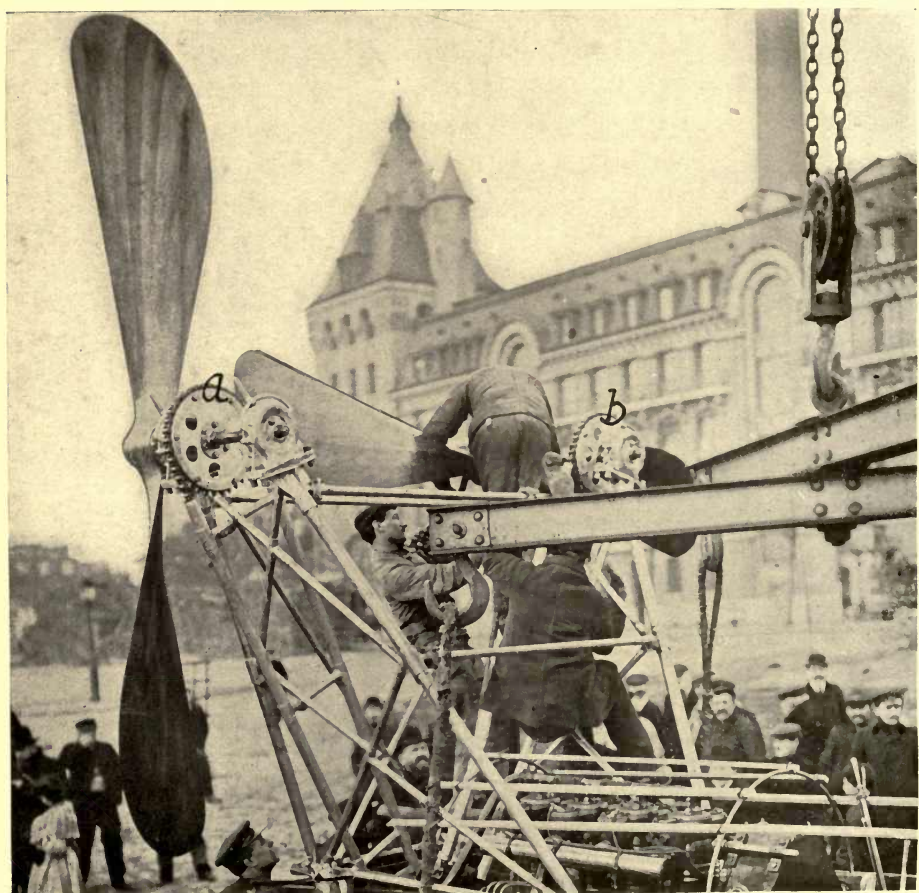

FIGURE 140.—Double-Chain Transmission in Hydroplane Driven by Aerial Propellers.

CHAPTER SEVEN

TRANSMISSION ELEMENTS

Except in the case of a flying machine in which the propeller can be mounted directly upon the engine crankshaft, it is necessary to have some sort of a transmission to communicate the power from the motor to the propelling element. In a number of the most successful present-day aeroplanes the designers have not found it easy to make engine location and engine speed readily coincident with propeller location and propeller speed, so are compelled to utilize transmissions of one type or another for the purposes of transmitting the power and changing the relative speeds of rotation.

Propeller-driving arrangements now common in aeroplane practise are those shown in Figures

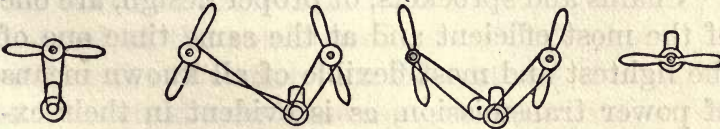

FIGURE 133.

FIGURE 134.

FIGURE 135.

FIGURE 136.

Comparison of Aeroplane Transmission Systems.

133, 134, and 136. The first of these permits the propeller to run slower than the engine, as in the monoplanes illustrated in Figures 141, 162, and

198; the second is the means of driving the oppositely rotating propellers on the Wright and the Cody biplanes, as is more clearly shown in Figure 188; while the fourth is the widely-favored plan of mounting the propeller directly on the engine shaft, as is shown in many of the illustrations herein.

A transmission is imperatively necessary when more than one propeller, not on the engine shaft, is run from a single motor as in the machines illustrated in Figures 20, 32, 33, 78, 79, 107, 134, 140, and 188.

The change-speed gear, so necessary in automobiles and other land vehicles to allow advantageous application of the power under greatly varying conditions of operation—up and down hills, over soft and hard surfaces, etc.—is not required in flying-machine transmissions because the conditions under which aerial vehicles operate present far less variation in so far as the matter of power demand is concerned.

CHAINS AND SPROCKETS

Chains and sprockets, of proper design, are one of the most efficient and at the same time one of the lightest and most flexible of all known means of power transmission, as is evident in their exceedingly extensive application to bicycles, automobiles, etc. This type of transmission has, moreover, given good results in several of the most successful aeroplanes so far constructed.

In the use of chains it is essential to employ only the highest quality materials and the most

approved designs. Even with these factors closely looked after there is a certain amount of unavoidable stretch in a chain, due to the accumulated wear at each link and rivet. Lubrication, too, must be provided for, preferably by occasionally soaking in a mixture of graphite and melted tallow, or by dosing liberally from time to time with suitable oils.

Obviously, the difficulty of keeping a chain clean and properly lubricated is much less on a flying machine than it is on an automobile or bicycle, it being much less exposed to dust.

Chains that are very long require to be guided by small idlers or sleeves of some sort. An example of the use of tubular steel sleeves to guide long chains is afforded in the transmission of the Wright machine, illustrated in Figure 188, in which it is seen that the chain for the propeller *a* passes through the two slightly-diverging tubes *b* and *c*, while that for the propeller *d* goes through the tubes *e f*, crossed to reverse the motion. This very peculiar arrangement, which has been widely denounced as unmechanical, has for its object the reversal of the rotation of one of the propellers so that the two may turn in opposite directions, as is required to balance the gyroscopic and other reactions. That it has serious objections, and is justified only as an experimental construction, has been suggested in several cases of chain breakage in the use of this particular type of machine. In the Cody biplane (see Page 202) chains specially made for this purpose by an English manu-

facturer are used, their special feature being the provision of a definite amount of lateral flexibility.

Seemingly a better plan, certain to afford about the same results, would be to provide the engine camshaft with heavier driving gears and a heavy end bearing, so that one of the propellers could be driven from a sprocket on this shaft, the cam gearing reversing the motion as is suggested in Figure 135. The two-to-one ratio of drive secured in this way could be readily compensated by making the right propeller sprocket twice as large as the left.

Another chain transmission, used to drive aerial propellers on a hydroplane boat, is illustrated in Figure 140.

With proper designing, chains can be satisfactorily run at speeds as high as 2,000 feet a minute. Such speeds particularly require ample clearance between tooth and roller.

BLOCK CHAINS

Block chains, of the type pictured in Figure 137, are distinguished by the use of solid steel blocks for each alternate link. Block chains are



FIGURE 137.—Block Chain.

much used on bicycles but are objected to on automobiles because they run very hard when not clean—an objection that is not a very serious one from the flying-machine standpoint. Their advantages are their greater width of tooth and rivet-bearing surface for a given width of chain, their simpler construction and their materially lower price.

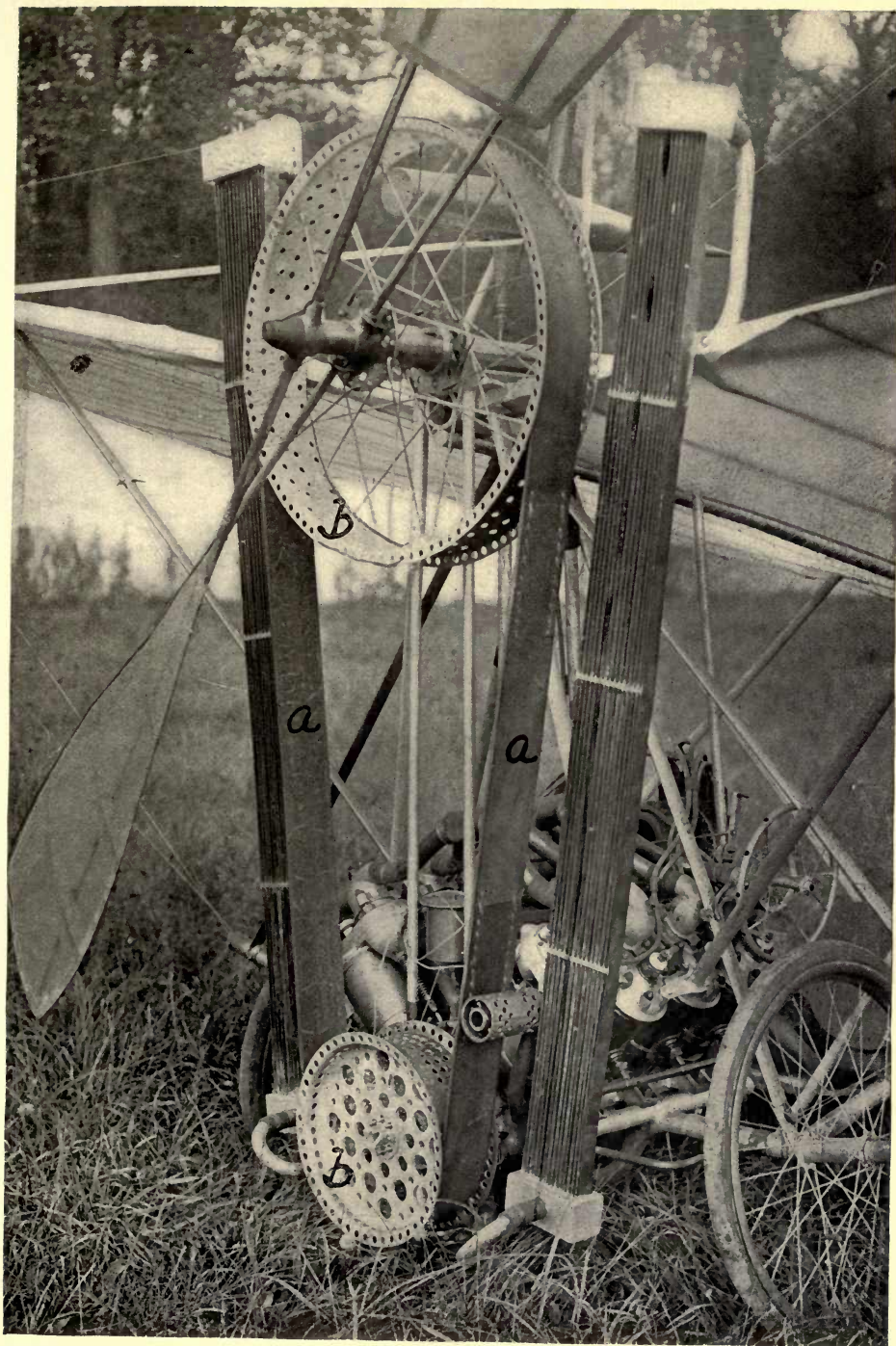

FIGURE 141.—Belt Transmission in Recent Santos Dumont Monoplane. This machine, while it was not conspicuously successful, is a notable example of what can be done with belt transmission, the light weight of the pulleys *b b* and the ordinary construction of the belt *a a* being particularly interesting.

ROLLER CHAINS

Roller chains, made entirely of links, rollers, and rivets, as shown in Figure 138, are very smooth running even when very dirty and are capable of running smoothly over smaller sprockets than can be used with



FIGURE 138.—Roller Chain.

block chains. The greater width of roller chains for given bearing widths on rivets and sprocket teeth is not a serious objection in most cases, since it involves no materially greater weight.

MISCELLANEOUS

Silent chains and link belts are made very wide, of great numbers of metal or leather links, and call for special sprockets or pulleys. In the case of some link belts the construction is such that a small toothed sprocket can be used at one end and a large smooth pulley at the other, the belt working satisfactorily over both.

What are known as “cable chains”—not made to run over sprockets—are much used in place of sash cords and the like. Their strength and flexibility renders them ideal for use in control connections where corners must be turned.

BLOCK CHAINS

Pitch	Inside Width	Outside Width	Weight to Foot	Breaking Load
$\frac{1}{2}$ inch	$\frac{1}{2}$ inch	$\frac{3}{4}$ inch	.073 pound	300 pounds
1 inch	$\frac{3}{4}$ inch125 pound	1250 pounds
1 inch	$\frac{7}{8}$ inch187 pound	1500 pounds
1 inch	1 inch219 pound	1600 pounds
1 inch	$1\frac{1}{8}$ inch312 pound	1800 pounds
1 inch	$1\frac{1}{4}$ inch344 pound	1950 pounds
1 inch	$1\frac{3}{8}$ inch388 pound	2128 pounds
1 inch	$1\frac{1}{2}$ inch	$\frac{5}{8}$ inch	.5 pound	2400 pounds
1 inch	$1\frac{5}{8}$ inch	$1\frac{1}{8}$ inch	.53 pound	2400 pounds
$1\frac{1}{16}$ inches	$1\frac{3}{4}$ inch281 pound	1850 pounds
$1\frac{1}{8}$ inches	1 inch312 pound	1950 pounds
$1\frac{1}{4}$ inches	$1\frac{1}{2}$ inch375 pound	2130 pounds
$1\frac{3}{8}$ inches	$1\frac{3}{4}$ inch	$\frac{3}{4}$ inch	.76 pound	4032 pounds

STANDARD AMERICAN ROLLER CHAINS

Pitch	Inside Width	Diameter of Rolls	Weight to Foot	Working Load
$\frac{1}{2}$ inch	$\frac{3}{8}$ inch	$\frac{1}{8}$ inch	.625 pound	4000 pounds
$\frac{1}{2}$ inch	$\frac{3}{8}$ inch	$\frac{1}{8}$ inch	.625 pound	5000 pounds
$\frac{1}{2}$ inch	$\frac{3}{8}$ inch	$\frac{1}{8}$ inch	.687 pound	4000 pounds
$\frac{1}{2}$ inch	$\frac{3}{8}$ inch	$\frac{1}{8}$ inch	.687 pound	5000 pounds
$\frac{1}{2}$ inch	$\frac{3}{8}$ inch	$\frac{1}{8}$ inch	.875 pound	6000 pounds
$\frac{1}{2}$ inch	$\frac{3}{8}$ inch	$\frac{1}{8}$ inch	1.25 pounds	7500 pounds
$\frac{1}{2}$ inch	$\frac{3}{8}$ inch	$\frac{1}{8}$ inch	1.125 pounds	6000 pounds
1 inch	$\frac{1}{2}$ inch	$\frac{1}{8}$ inch	1.125 pounds	5000 pounds
1 inch	$\frac{1}{2}$ inch	$\frac{1}{8}$ inch	1.25 pounds	6000 pounds
1 inch	$\frac{1}{2}$ inch	$\frac{1}{8}$ inch	1.25 pounds	5000 pounds
1 inch	$\frac{1}{2}$ inch	$\frac{1}{8}$ inch	1.375 pounds	6000 pounds
1 inch	$\frac{1}{2}$ inch	$\frac{1}{8}$ inch	1.5 pounds	6000 pounds
1 inch	$\frac{1}{2}$ inch	$\frac{1}{8}$ inch	2. pounds	7500 pounds
1 1/2 inches	$\frac{3}{4}$ inch	$\frac{1}{8}$ inch	1.25 pounds	6000 pounds
1 1/2 inches	$\frac{3}{4}$ inch	$\frac{1}{8}$ inch	1.5 pounds	6000 pounds
1 1/2 inches	$\frac{3}{4}$ inch	$\frac{1}{8}$ inch	1.875 pounds	9000 pounds
1 1/2 inches	$\frac{3}{4}$ inch	$\frac{1}{8}$ inch	2. pounds	9000 pounds
1 1/2 inches	$\frac{3}{4}$ inch	$\frac{1}{8}$ inch	1.625 pounds	10000 pounds
1 1/2 inches	$\frac{3}{4}$ inch	$\frac{1}{8}$ inch	1.75 pounds	10000 pounds
1 1/2 inches	$\frac{3}{4}$ inch	$\frac{1}{8}$ inch	2.437 pounds	12000 pounds
1 1/2 inches	$\frac{3}{4}$ inch	$\frac{1}{8}$ inch	3.875 pounds	15000 pounds
2 inches	$\frac{1}{2}$ inch	1 inch	3.5 pounds	30000 pounds
2 inches	1 1/2 inches	1 1/2 inches	4.375 pounds	35000 pounds

ROLLER CHAINS

Pitch	Inside Width	Outside Width	Diameter of Rolls	Weight to Foot	Breaking Load
$\frac{1}{2}$ inch	$\frac{1}{2}$ inch	.295 inch	.197 inch	.109 pound	700 pounds
$\frac{1}{2}$ inch	$\frac{1}{2}$ inch303 inch	.172 pound
$\frac{1}{2}$ inch	$\frac{1}{2}$ inch303 inch	.203 pound
$\frac{1}{2}$ inch	$\frac{1}{2}$ inch303 inch	.266 pound
$\frac{1}{2}$ inch	$\frac{1}{2}$ inch	.515 inch	.315 inch	.390 pound	2016 pounds
$\frac{1}{2}$ inch	$\frac{1}{2}$ inch	.64 inch	.330 inch	.453 pound	2240 pounds
$\frac{1}{2}$ inch	$\frac{1}{2}$ inch303 inch	.156 pound
$\frac{1}{2}$ inch	$\frac{1}{2}$ inch303 inch	.172 pound
$\frac{1}{2}$ inch	$\frac{1}{2}$ inch303 inch	.266 pound
$\frac{1}{2}$ inch	$\frac{1}{2}$ inch	.625 inch	.4 inch	.437 pound	2800 pounds
$\frac{1}{2}$ inch	$\frac{1}{2}$ inch	.64 inch	.4 inch	.515 pound	2800 pounds
$\frac{1}{2}$ inch	$\frac{1}{2}$ inch	.718 inch	.476 inch	.75 pound	3808 pounds
$\frac{1}{2}$ inch	$\frac{1}{2}$ inch	.781 inch	.476 inch	.78 pound	3808 pounds
$\frac{1}{2}$ inch	$\frac{1}{2}$ inch	.77 inch	.476 inch	.69 pound	3696 pounds
$\frac{1}{2}$ inch	$\frac{1}{2}$ inch315 inch	.219 pound
$\frac{1}{2}$ inch	$\frac{1}{2}$ inch315 inch	.25 pound
$\frac{1}{2}$ inch	$\frac{1}{2}$ inch315 inch	.281 pound
$\frac{1}{2}$ inch	$\frac{1}{2}$ inch	.812 inch	.475 inch	.75 pound	4816 pounds
$\frac{1}{2}$ inch	$\frac{1}{2}$ inch	.75 inch	.5 inch	.81 pound	4816 pounds
$\frac{1}{2}$ inch	$\frac{1}{2}$ inch	.812 inch	.5 inch	.81 pound	4816 pounds
$\frac{1}{2}$ inch	$\frac{1}{2}$ inch	.837 inch	.5 inch	1.0 pounds	4816 pounds
$\frac{1}{2}$ inch	$\frac{1}{2}$ inch	.837 inch	.551 inch	1.19 pounds	7056 pounds
$\frac{1}{2}$ inch	$\frac{1}{2}$ inch	.812 inch	.562 inch	.89 pound	6048 pounds
$\frac{1}{2}$ inch	$\frac{1}{2}$ inch	.968 inch	.562 inch	1.2 pounds	6048 pounds
$\frac{1}{2}$ inch	$\frac{1}{2}$ inch	.843 inch	.625 inch	1.17 pounds	7056 pounds
$\frac{1}{2}$ inch	$\frac{1}{2}$ inch	.968 inch	.625 inch	1.29 pounds	7056 pounds
$\frac{1}{2}$ inch	$\frac{1}{2}$ inch	1.093 inches	.625 inch	1.44 pounds	7056 pounds

* Bicycle Chains.

CABLE CHAINS

Pitch	Plates	Outside Width	Depth	Thickness of Plates	Weight to Yard	Breaking Load
† 1/2 inch	2 & 1	.117 inch	.112 inch321 pound	160 pounds
† 1/2 inch	2 & 2	.152 inch	.112 inch433 pound	225 pounds
1/2 inch	1 & 2	.225 inch	.185 inch	.045 inch	.175 pound	440 pounds
1/2 inch	2 & 2	.268 inch	.185 inch	.045 inch	.234 pound	600 pounds
1/2 inch	2 & 3	.315 inch	.185 inch	.045 inch	.292 pound	800 pounds
1/2 inch	3 & 4	.405 inch	.185 inch	.045 inch	.409 pound	1100 pounds
1/2 inch	4 & 5	.495 inch	.185 inch	.045 inch	.526 pound	1300 pounds
1/2 inch	1 & 2	.20 inch	.212 inch	.035 inch	.116 pound	460 pounds
1/2 inch	2 & 2	.24 inch	.212 inch	.035 inch	.187 pound	700 pounds
1/2 inch	2 & 3	.28 inch	.212 inch	.035 inch	.258 pound	900 pounds
1/2 inch	3 & 4	.36 inch	.212 inch	.035 inch	.357 pound	1340 pounds
1/2 inch	4 & 5	.44 inch	.212 inch	.035 inch	.416 pound	1740 pounds
1/2 inch	1 & 2	.20 inch	.315 inch	.04 inch	.312 pound	800 pounds
1/2 inch	2 & 2	.24 inch	.315 inch	.04 inch	.375 pound	1560 pounds
1/2 inch	2 & 3	.28 inch	.315 inch	.04 inch	.50 pound	1900 pounds
1/2 inch	3 & 4	.36 inch	.315 inch	.04 inch	.75 pound	2500 pounds
1/2 inch	4 & 5	.44 inch	.315 inch	.04 inch	.875 pound	3500 pounds
1/2 inch	1 & 2	.359 inch	.267 inch	.067 inch	.322 pound	680 pounds
1/2 inch	2 & 2	.406 inch	.267 inch	.067 inch	.482 pound	990 pounds
1/2 inch	2 & 3	.473 inch	.267 inch	.067 inch	.562 pound	1280 pounds
1/2 inch	3 & 4	.607 inch	.267 inch	.067 inch	.723 pound	1800 pounds
1/2 inch	4 & 5	.741 inch	.267 inch	.067 inch	.887 pound	2400 pounds

† These can be run as block chains over sprockets.

REVERSIBLE SPROCKETS

Sprockets made exactly the same on both sides, so that it does not matter which way around they are fixed in place, in some situations constitute a useful provision against wear. By simply turning such a reversible sprocket around entirely new wearing surfaces are presented to the chain. This applies, of course, only to transmissions in which all or most of the work is done in one direction of rotation.

For best results, sprockets with not more than 50 nor less than 14 teeth are advised by the most conservative chain manufacturers.

MISSED TEETH

In the design of very large sprockets it often is a useful expedient to use less than a tooth for every link, leaving out every other tooth, for example. This reduces friction, slightly lowers weight,

cheapens construction, and is quite unobjectionable, except that it is not applicable to small sprockets.

SHAFTS AND GEARS

Shafts and gears for the transmission of power are the soundest of sound engineering, though a given amount of material will not as readily sustain a given torsional stress in a shaft as it will a corresponding tensile stress in a chain, and gears lack the flexibility of chain-and-sprocket transmission. Advantages of shaft-and-gear transmission are its ready application to greater distances than can be effectively worked over by chains, the small space it occupies, its silence and smoothness of running, and the facility with which it can be encased and lubricated.

SHAFTS

Hollow rod or tubing, of the finest alloy steels, of circular cross section, and of large diameter and with comparatively thin walls, is much the highest grade material—the strongest and lightest—that can be used for shafting. Solid shafts of course have their uses, as for passing through small holes in situations where more room cannot very readily be provided, but, though affording the greatest strength that can be had in a given space they do not begin to be as strong for a given weight as hollow material. Always when it is possible unbroken shaft lengths should be used in any machine compelled to work under heavy duty, but when there are reasons preventing this, excellent

joints can be made in shaft materials by brazing, or by autogenous or electric welding. In Chapter 11 further data is given concerning stock sizes of shafting and tubing, and methods of assembling.

SPUR GEARS

Spur gears for the transmission of power are difficult to render perfectly smooth running because of the slight amount of backlash that results from the necessary slight clearance given between the teeth to prevent binding. Consequently they are used only when cost has to be considered, or in situations in which peculiar conditions apply, such as the necessity for endwise meshing of the teeth in sliding gears for automobiles. Spur gears can transmit power only between parallel shafts, and it is most essential that this requisite parallelism be perfectly secured and maintained by stiff construction and suitable bearings. Case-hardened steel gears are the only kind suitable for heavy power transmission with light weights. Theoretically with properly cut teeth there is only rolling contact between the teeth of meshed gears, but practically there is enough sliding friction to warrant the provision of the tough shell that is produced by suitable methods of case-hardening. With such case-hardening, the tough interiors of the gear teeth resist breakage, while their hardened external shells withstand wear.

Spur-gear drives have been experimented with in one or two of the Voisin machines (see Chapter

12), with a view to running the single propeller slower than the engine.

Bronze or brass gears meshed with steel, or gears built up laterally of rawhide and metal layers, are very silent running, but lack the requisite strength and durability for the continued transmission of much power with small sizes. Gears of these materials are much used for camshaft, circulating-pump, lubricator, and magneto driving.

The teeth of gears are cut on three principal systems—the involute, the epicycloid, and the “stub.” The pitch line of a gear is the working diameter—about the height of a tooth less than the actual diameter. The “pitch line” of a pair of meshed gears can be seen when they are running, appearing as a sort of shadow line about midway of the tooth lengths. The “pitch” of gears has reference to the number of teeth per inch of diameter—“diametral pitch”—and is the number of teeth in 3.1416 inches of the pitch line. The proper pitch for given conditions of speed, loading, etc., as well as the width of gears, always must be determined by exhaustive and competent consideration of the circumstances of the particular case.

BEVEL GEARS

Just as spur gears are suitable for the transmission of power between parallel shafts, bevel gears are designed to transmit it “around corners”—between shafts at angles to each other. Aside from the correct tooth outlines, which are the same

for bevel gears as for spur gears, the essential thing in bevel-gear design is that all lines prolonged from the tooth surfaces must meet at the point where the axes of rotation of the gears would meet if prolonged. To explain this more simply, the requirement is that the gears be adjacent sections of two toothed cones, of the same or different altitudes, but with points together and sides in contact. Miter gears are bevel gears with angles of 45° , so that both gears of a pair are alike. Such gears are used at *a a* and *b*, Figures 20 and 107, respectively.

STAGGERED AND HERRINGBONE TEETH

By placing two similar spur gears side by side, with the teeth of one opposite the space between the teeth in the other, and meshing the staggered-tooth gear thus formed with another of similar construction, backlash and rough operation can be largely eliminated. By the use of more than two gears in each element the operation can be still further improved until with an infinity of steps in the gear the action would be almost perfect. Such an infinity of steps is practically secured in the helical gear, in which each tooth runs at a slant across the gear face. An objection to helical gears is that the slant of their teeth tends to force them out of mesh sidewise, so for all but the lightest power transmission the double-helical, the so-called "herringbone" gear, is to be preferred. In this type each tooth has a symmetrical double slant from a point on the center of the gear face to its edges, so

that a tendency to work to one side is neutralized by a corresponding tendency to work to the other. The helical and herringbone systems of tooth formation are applicable to bevel gears as well as to spur gears, though in the first case they are much more expensive to produce.

BELTS AND PULLEYS

For the transmission of large amounts of power, belt-and-pulley combinations tend to work out very heavy or inefficient, for which reason they find little application in light-weight power plants except for driving fans, lubricators, and other light accessory devices. An exception is the case of the motorcycle, in many forms of which belt transmission is used with success. The great advantage of belt-and-pulley transmission is its extreme flexibility and its tendency to cushion and eliminate slight irregularities in driving by its tendency to slip under sudden increase of load.

PULLEY CONSTRUCTION

Pulleys are variously constructed of wood and metal, and with flat, grooved, and crowned faces. In seeking extreme light weight with a requisite strength, a rim of wood or sheet steel, with wire spokes to complete it, is undoubtedly the ideal construction. For a given size, grooved pulleys, by their binding action upon the round or V-shaped belts employed with them transmit the most power, but also lose the most in friction. For flat belts wide flat pulleys can be used if the belt is perfectly

uniform and the pulleys are correctly alined, but a preferable construction is the crowned pulley, with center slightly higher than the edge, so that it holds the belt on by the resistance opposed by the edges of the latter to stretching over the high pulley center.

Metal pulleys often are faced with leather or other material, cemented on to increase belt adhesion.

Idlers are pulleys arranged to press against belts running over other pulleys that transmit and receive the power, so that the tension and consequent adhesion can be adjusted by variation of the idler pressure.

BELT MATERIALS

Belts are mostly made of leather, rawhide, canvas, and canvas and rubber, and may be flat, round, or V-shaped, to fit corresponding pulleys. Some motorcycle and light automobile belts are made of regular link chains with helical leather wrappings to contact with the pulleys. The advantage of this construction is the elimination of stretch. Belt dressings usually are employed to secure proper adhesion to the pulleys without the use of undue belt tension, which causes enormous friction losses.

Interesting applications of belt-and-pulley transmission to aeroplanes are shown in Figures 141 and 217.

CLUTCHES

Up to the present time there has been little use of clutches in aeroplane transmissions, but there is

no doubt but what some such disengaging device will become increasingly necessary as gliding flight becomes better understood and therefore more frequently practised. Present propellers, rather strongly held against rotation when the motor is stopped, must present much more resistance to forward movement (besides tending to tilt the machine when only one is used) than could be the case if they were, on occasion, allowed to spin freely on their shafts.

The type of clutch most suitable for this service is, of course, an undetermined question. The various forms of friction clutches—common disk, cone, contracting, and expanding constructions used in automobile practise—might have the advantage that at the end of a period of gliding they would permit utilization of the propeller as a sort of windmill wherewith to start the engine, but it is more probable that the positiveness, lightness, and durability of simple jaw clutches will prove to be of more definite merit.

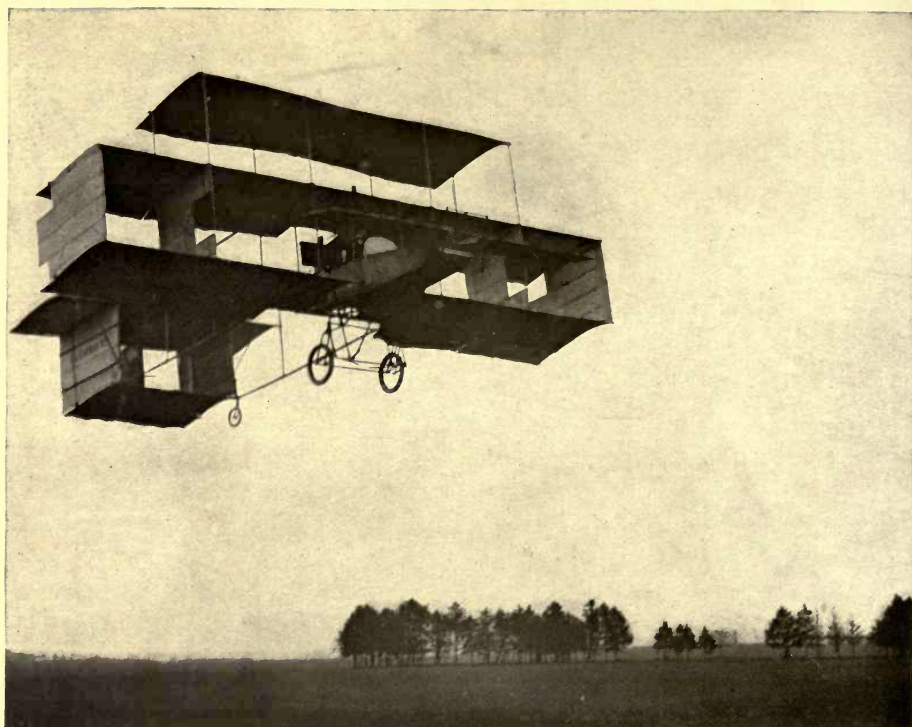

FIGURE 142.—Voisin Biplane Modified into a Triplane.

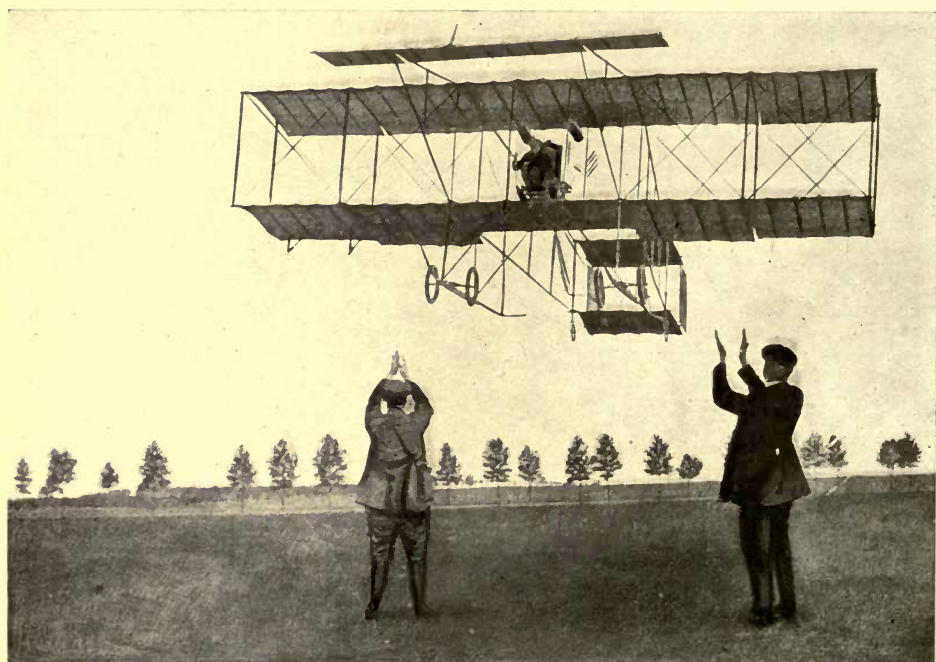

FIGURE 143.—Henry Farman's Biplane in Flight.

CHAPTER EIGHT

BEARINGS

From nearly every vital standpoint a most important element in any mechanism are the bearings, since it is upon the integrity of these wearing surfaces that continued serviceability depends, besides which a minimization of the friction losses in bearings directly and materially affects the amount of power required to run the machine. In aerial vehicles the importance of durable bearings, capable of long-continued operation without attention or adjustment, and of types to minimize power lost through friction, are of the utmost importance.

In the history of mechanism an immense variety of bearings has been devised to serve as great a variety of needs, but in present-day engineering sound practise has settled upon a few long-tested forms of ball, roller, and plain bearings as most suitable for all ordinary purposes. Each of the different types in established use has its special merits, and, in most cases, demerits, so a choice is usually dictated by special conditions to be met. It therefore is possible to generalize only to the extent of emphasizing the importance of liberal sizes and best materials, as sure means of affording strength, immunity from heating, and slow wear.

BALL BEARINGS

Ball bearings, substituting rolling for sliding contact as a means of diminishing friction, are very old in their conception, but first came into general practical use with the advent of the bicycle. The principle upon which they operate, as compared with the conditions that apply in a plain bearing, can be best appreciated from considering the analogous cases of a flat board laid on a flat surface, to represent the plain bearing, and the same board over the same surface but with a number of marbles beneath it, to represent the ball bearing. The difference in friction in the two cases will be appreciated by any one.

Ball bearings manifest their superiority in the reduction of friction loads most markedly at the moment the mechanism is started in motion, the starting effort when they are used being practically no greater than the effort necessary to maintain the mechanism in operation. In the best types of plain bearings, in which running friction often is reduced to a very small degree, the friction load at starting always is vastly greater.

The best types of modern ball bearings, properly applied, can be counted upon to reduce friction losses to as little as from .0012 to .0018 of the total load per bearing.

ADJUSTABLE BALL BEARINGS

The original and still a prevailing type of ball bearing is the so-called "cup-and-cone", or adjustable bearing, in which the inner race *a*, Figure 144,

takes the general form of the frustum of a cone, while the outer race is cup-like, as at *b*, the ball circle *c* being placed between the two. Bearings of this type are now extensively used only in bicycles and in other very light machinery, or, to state the case more strictly, in mechanisms in which excessive sizes can be used in proportion to the loads.

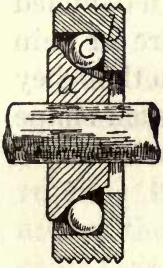

FIGURE 144.
Adjustable Ball
Bearing

The fundamental theory underlying the construction of the cup-and-cone type of ball bearing is that of its adjustability—a theory, however, that is found to fall very flat upon analysis. Of course, it is evident that means of moving the cone endwise on its shaft, or the cup endwise in its housing, must bring the two closer together or farther apart, with corresponding variation in the closeness of the fit upon the ball circle. This is all right in setting up a new bearing but as a means of using a worn bearing its merits are less apparent, for it is an indisputable fact that such wear as takes place must take the form of grooves worn in the races, which being admitted, the conclusion is inevitable that this groove is certain to be deeper on the loaded side of the non-rotating race. This being the case, any attempt at adjustment simply results in the appearance of tight and loose positions—alternate binding and rattling—as the bearing is turned, causing rough operation and rapid breakdown, and thoroughly upholding the contention of the advocates of annu-

lar bearings to the effect that any ball bearing worn enough to require adjustment is worn enough to throw away.

Most high-grade adjustable ball bearings are made with "retainers" to hold the balls assembled in the circle. Such retainers usually are of thin sheet metal, lightly embracing the balls so that they cannot fall apart when handled, but of such shape that they do not come into contact with the races when the bearing is assembled.

ANNULAR BALL BEARINGS

Annular ball bearings, of the type illustrated in Figure 145, are a decidedly modern and advanced development in engineering, only recently commencing to find extensive application in auto-

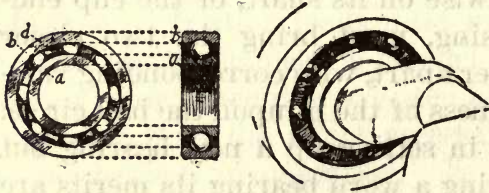

FIGURE 145.—Annular Ball Bearing. Plan, Sectional, and Perspective Views.

mobiles and in a few other special examples of exceedingly high-grade machinery.

In the evolution of annular-ball bearings the ideal held in view has been to substitute in place of adjustment a decreasing necessity for adjustment, by providing ball and race surfaces of the hardest and strongest materials and the utmost accuracies of fit. How completely this ideal is embodied in some of the best modern annular bearings will be appreciated from the fact that these bearings, used in sizes properly proportioned to

the work to be done, protected from grit and rust, and properly lubricated, may be relied upon to outlast almost any other part of any mechanism in which they can be placed.

All successful annular bearings consist essentially of the inner race a and the outer race b , Figure 145, both ring-like, and symmetrical or approximately symmetrical in their sectional aspect, with the ball circle between them, the balls running in grooves of circular cross section, the arcs of these cross sections being of slightly greater radii than the radii of the balls themselves. This results in two-point contact, with the two points in the same rotational plane and on opposite sides of the balls.

Many different schemes have been devised for assembling annular ball bearings in a permanent and satisfactory manner, it being obvious that a full circle of balls cannot be placed in races of the type shown at a and b , Figure 145, without some special scheme. One of the best expedients is that shown in this Figure, in which only a half-circle of balls is placed in the bearing, these balls being subsequently spaced out to fill the entire circle by the interposition of the small spacing springs shown at d .

Another construction is that sketched in Figure 146, in which openings e and f are made in the sides of the races, the balls being forced through these, one at a time, by the application of slight pressure. It is obvious that this scheme weakens the races to some extent, besides which in some

forms it has been found to permit escape of the balls under certain conditions, though this is rendered less likely to occur by the expedient of crossing the two openings, *e* and *f*, so that a slight relative rotation between the two races is required for the insertion or removal of each ball.

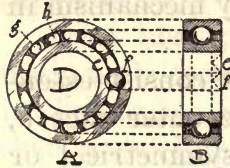

FIGURE 146.—Full Type Annular Ball Bearing. The balls are introduced through the cross slots, *e* and *f*.

Another scheme that utilizes a half-circle of balls, thus avoiding cutting the races, is to use spreading retainers of the type shown in Figure 147, instead of the spring separators shown in Figure 145.



FIGURE 147.—Annular Ball Bearing. A sheet metal cage is employed to maintain the spacing of the balls.

A non-adjustable ball bearing with flat instead of grooved outer ball track is shown in section in Figure 148, in which it is seen that assembling with a full circle of balls is effected simply by placing the races together sidewise. Flat surfaces will not, however, carry as heavy loads with given sizes as can be carried in grooved races.

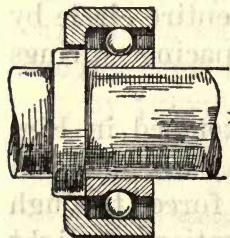

FIGURE 148.—Annular Ball Bearing.

Annular ball bearings of the type illustrated in Figure 145 are capable of perfectly satisfactory operation at most enormous rotational speeds—up to 10,000 and 12,000 revolutions a minute—will stand such shocks as are imposed on gas-engine crankshafts, and are commonly used in a

great range of sizes, from bearings less than one inch in diameter up to the sizes required for heavy hoisting cranes, railway-car axles, turbines, etc.

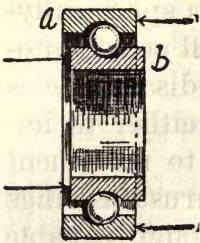

FIGURE 149.—Annular Ball Bearing Subjected to Thrust.

It is rather a remarkable fact that annular ball bearings of the type illustrated in Figure 145 prove remarkably well adapted to sustain thrust as well as the radial loads to which they would seem more particularly adapted. The reason for this seems to be disclosed in some such condition as is suggested in

Figure 149, in which it is seen that crowding the races *a* and *b* in the contrary directions indicated by the arrows has the effect of rolling the balls slightly upon the side surfaces of the respective race grooves, thus causing them to receive fairly direct side support against the load, instead of the wedging that would be assumed from a more casual consideration.

It is considered by the best authorities, however, that combined thrust and radial loading of the same bearing is always objectionable unless the sum total of the loads is materially less than the rated capacity of the size of bearing used. For this reason it is regarded as best practise in such conditions to use two bearings placed closely together, one provided with an endwise-sliding fit in its housing so that it can carry radial load only, and the other made radially free so that it can carry thrust load only.

Special types of ball thrust bearings are made

in the form illustrated in Figure 150, in which the load is applied through the flat race *a*, through the ball circle, and to the race *b*, which is either ground with a spherical surface, or placed in a spherically-seated holder, so that adjustment will occur auto-

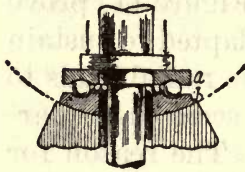

FIGURE 150. — Ball Thrust Bearing. The flat upper race *a* is mounted on the shaft, while the race *b* seats against a spherical surface, permitting it to adjust itself by movement as suggested by the dotted lines.

matically to slight discrepancies of alignment due either to imperfect fitting or to movement while running. Thrust bearings of these types, though capable of carrying very heavy loads, cannot be run at as high speeds as the radial bearings illustrated in Figure 142 when used for thrust.

All the annular bearings so far shown constitute permanently assembled units, requiring no retainers to keep them together. Thrust bearings, however, of the type illustrated in Figure 150, often are made with retainers to hold the ball circles together for convenience in handling.

In applying annular ball bearings it is necessary to turn in the housings and on the shafts simply plain cylindrical seats, that for one race being a light driving fit while that for the other is a close sliding fit. Usually the inner race is given the driving fit.

A frequent misconception with reference to ball bearings is that which regards them as having a tendency to force apart the balls under load, as would be the case at *A*, Figure 151, were the shaft *a* to bear as indicated by the large arrow on the

two balls *b* and *c*, resting on the plane surface, in which case the balls would tend to separate as indicated by the small arrows. The

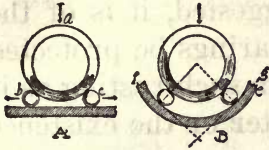

FIGURE 151.—Resultants of Load on Ball Bearing.

actual condition in the ball bearing, however, is that sketched at *B*, Figure 151, in which the curved surface *e* is

substituted for the plane surface so that the load represented by the large arrow is squarely met by the tangents *f* and *g*, normal to which come the two resultant thrusts indicated by the small arrows. This point once grasped it will be readily appreciated how erroneous are notions to the effect that ball bearings of the full type operate with pressure between adjacent balls (which of course revolve in opposite directions, as shown at *g* and *h*, Figure 146) or that the balls exert pressure on spacer springs or retainers used to hold them apart as in Figures 145 and 147. Were the condition illustrated at *A*, Figure 151, to hold true, ball bearings always would operate with the lost motion between the balls represented by a separation at the bottom, instead of at the top as is actually proved the case by the click which every one has noticed in bicycle ball bearings, and which is due to the balls falling one after another over the highest point in the circle of rotation.

It is a common idea that ball bearings do not require to be lubricated. This is absolutely wrong, and serious injury can be quickly done to a ball bearing by any failure to lubricate properly. It is a fact though that very infrequent and slight lubri-

ation is sufficient for most ball bearings, provided they are properly housed.

As has been previously suggested, it is of the utmost importance that ball bearings be protected from the entry of grit, and from such rusting as is sure to follow the entry of water or the existence of acid in the lubricant used.

Ball bearings depend absolutely for durability and efficiency on the almost perfect wearing surfaces that are provided, it being well established that minute inequalities in these surfaces do not wear smooth but tend to break down into greater inequalities, from all of which it can be readily inferred that quick deterioration is the logical sequence of dirt or rust. Even graphite used as a lubricant is detrimental in good ball bearings, in which the fits are so close as not to provide sufficient clearances for the exceedingly small particles of graphite to pass between adjacent surfaces.

Most manufacturers of ball bearings specify the types of mountings they consider most suitable for housing and protecting their particular product—for keeping out water and grit, and retaining the lubricant. It generally pays, in the designing of most mechanisms, to pay close regard to such suggestions.

The following tables show sizes, rated load capacities, and weights of one of the oldest makes of modern ball bearings, to which most other makes conform exactly in the use of the same metric sizes, and more or less closely in qualities of design and material:

ANNULAR BALL-BEARING SIZES, CAPACITIES, AND WEIGHTS

LIGHT-WEIGHT SERIES

BORE		DIAMETER		WIDTH		Load * in pounds	Weight in pounds
Milli- meters	Approximate equivalent in inches	Milli- meters	Approximate equivalent in inches	Milli- meters	Approximate equivalent in inches		
10	0.3937	30	1.1811	9	0.3543	120	0.09
12	0.4724	32	1.2598	10	0.3937	140	0.10
15	0.5905	35	1.3779	11	0.4331	160	0.12
17	0.6693	40	1.5748	12	0.4724	250	0.18
20	0.7874	47	1.8503	14	0.5512	320	0.23
25	0.9842	52	2.0473	15	0.5905	350	0.26
30	1.1811	62	2.4410	17	0.6299	550	0.44
35	1.3779	72	2.8346	17	0.6693	600	0.66
40	1.5748	80	3.1496	18	0.7086	860	0.83
45	1.7716	85	3.3464	19	0.7480	950	0.96
50	1.9685	90	3.5433	20	0.7874	1009	1.09
55	2.1653	100	3.9370	21	0.8268	1160	1.36
60	2.3622	110	4.3307	22	0.8661	1550	1.75
65	2.5590	120	4.7244	23	0.9055	1670	2.28
70	2.7559	125	4.9212	24	0.9449	1820	2.50
75	2.9527	130	5.1181	25	0.9842	2130	2.63
80	3.1496	140	5.5113	26	1.0236	2650	3.22
85	3.3464	150	5.9055	28	1.1023	2850	3.87
90	3.5433	160	6.2992	30	1.1811	3400	4.84
95	3.7402	170	6.6929	32	1.2598	3750	5.94
100	3.9370	180	7.0866	34	1.3386	2950	7.17
105	4.1338	190	7.4803	36	1.4173	4600	8.48
110	4.3307	200	7.8740	38	1.4960	5000	10.26

MEDIUM-WEIGHT SERIES

10	0.5937	35	1.3779	11	0.4331	202	0.11
12	0.4724	37	1.4567	12	0.4724	220	0.14
15	0.5905	42	1.6555	13	0.5118	280	0.19
17	0.6693	47	1.8503	14	0.5512	370	0.25
20	0.7874	52	2.0473	15	0.5905	440	0.33
25	0.9842	62	2.4410	17	0.6693	620	0.53
30	1.1811	72	2.8346	19	0.7480	860	0.77
35	1.3779	80	3.1496	21	0.8268	1100	0.98
40	1.5748	90	3.5433	23	0.9055	1450	1.35
45	1.7716	100	3.9370	25	0.9842	1750	1.79
50	1.9685	110	4.3307	27	1.0630	2100	2.35
55	2.1653	120	4.7244	29	1.1417	2400	2.99
60	2.3622	130	5.1181	31	1.2205	2800	3.72
65	2.5590	140	5.5113	33	1.2992	3300	4.49
70	2.7559	150	5.9055	35	1.3779	4000	5.46
75	2.9527	160	6.2992	37	1.4567	4400	6.58
80	3.1496	170	6.6929	39	1.5354	5000	7.89
85	3.3464	180	7.0866	41	1.6142	5700	9.27
90	3.5433	190	7.4803	43	1.6929	6400	10.47
95	3.7402	200	7.8740	45	1.7716	7000	12.27
100	3.9370	215	8.4645	47	1.8504	7700	15.23
105	4.1338	225	8.8582	49	1.9291	8400	17.19
110	4.3307	240	9.4488	50	1.9685	10000	20.29

*Under uniform load; from 1/2 to 2/3 less under shock.

HEAVY-WEIGHT SERIES

BORE		DIAMETER		WIDTH		Load * in pounds	Weight in pounds
Milli- meters	Approximate equivalent in inches	Milli- meters	Approximate equivalent in inches	Milli- meters	Approximate equivalent in inches		
17	0.6693	62	2.4410	17	0.6693	850	0.56
20	0.7874	72	2.8343	19	0.7480	1050	0.85
25	0.9842	80	3.1496	21	0.8268	1320	1.14
30	1.1811	90	3.5433	23	0.9055	1600	1.56
35	1.3779	100	3.9370	25	0.9842	1900	2.00
40	1.5748	110	4.3307	27	1.0630	2200	2.58
45	1.7716	120	4.7244	29	1.1417	2500	3.33
50	1.9685	130	5.1181	31	1.2205	3400	4.18
55	2.1653	140	5.5118	33	1.2992	3900	5.07
60	2.3622	150	5.9055	35	1.3779	4400	6.12
65	2.5590	160	6.2992	37	1.4567	4900	7.22
70	2.7559	180	7.0866	42	1.6585	6200	10.54
80	3.1496	200	7.8740	48	1.8897	7300	14.58
90	3.5433	225	8.8582	54	2.1260	10000	20.15
100	3.9370	265	10.4320	60	2.3622	14000	33.44

*Under uniform load; from $\frac{1}{2}$ to $\frac{3}{8}$ less under shock.

By most manufacturers of ball bearings it is considered bad practise to attempt to divide a given load among several closely-spaced bearings, such attempts being almost always attended by difficulties unless special provision is made to prevent unequal distribution of the load on the two bearings, causing one to support greater loads than are calculated for it, with undue wear as a result. Nevertheless, annular ball bearings are now built with double grooves in single races, with the idea of sustaining a given load in a smaller circumferential space. Bearings of this type are so new that their success is fairly to be considered more or less problematical, though in many initial applications they appear to give excellent service. Obviously, nothing but the most superior accuracy can be considered permissible in a construction of this sort.

All ball bearings of any quality are constructed of the highest grades of alloy-steels made glass-hard throughout, or at least of high-grade carbon steels, casehardened. Both races and balls should be finished to mirror surfaces, to within $\frac{1}{50000}$ or $\frac{1}{100000}$ of an inch of true size, and the balls must be closely tested and selected for size and sphericity.

ROLLER BEARINGS

Roller bearings are analogous to ball bearings in that they substitute rolling for sliding friction, but instead of employing a point of contact on the surface of a sphere as in the ball bearing, a line contact is employed along the side of the cylinder or conical roller, the analogy given on Page 328 fitting this case if for the marbles there be substituted small rollers.

The difficulty of making rollers and races close enough to the theoretically true surfaces required is the one serious difficulty in the manufacture of roller bearings, since if anything materially short of the utmost possible perfection be tolerated the result is certain to be unequal wear, if not absolute breakage, of the rollers. Also, the idea that a roller bearing is capable of carrying greater loads than a ball bearing of approximately the same size—quality of materials and workmanship being equal—is probably erroneous, it being founded upon the incorrect theory that rollers afford greater areas of contact than balls. It is evident that, contact with the ball being an infinitely small point and that with the roller an infinitely narrow line, the

area in one case is theoretically no greater than the other, being zero in both cases. Practically, however, definite bearing area is secured in both types of bearings by the slight deformation of the bearing surfaces which cannot fail to result, even with the most resistant materials, under load. In the case of ball bearings under this deformation the point becomes a circle, while in the roller bearing the line becomes a rectangle and, with loads and materials similar in both cases, the deformations are found to be approximately so proportioned that the area of the circle in one case is practically as great as the area of the rectangle in the other, thus giving the ball bearing as great wearing surface as is secured in the roller bearing—not to consider the obvious advantages in ease of manufacture and perfection of operation in favor of the ball.

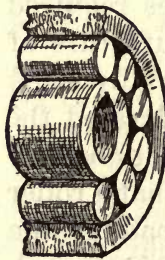

FIGURE 152.—
Cylindrical Roller Bearing.

CYLINDRICAL ROLLER BEARINGS

Cylindrical roller bearings usually are assembled in plain, cylindrical, ring-like races, as shown in Figure 152. Making the rollers very short tends to minimize any lateral inequalities of loading due to deviations from truly cylindrical form.

FLEXIBLE ROLLER BEARINGS

Flexible roller bearings, of the description illustrated in Figure 153, are a type possessing many excellent qualities, and therefore widely used

in cheaper automobiles and other classes of machinery. In these bearings, instead of attempting to

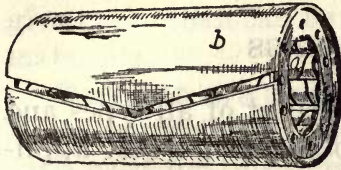

FIGURE 153.—Flexible Roller Bearing.

secure exceedingly accurate fits, the necessity for exceedingly accurate fitting is avoided by the scheme of making the rollers of steel strips,

flexible enough to adjust themselves to minor inequalities of shaft and housing. The rollers being hollow, as at *a*, with a helical opening between adjacent turns of the strips, the oil distribution is excellently provided for. The housing *b* is used as a liner for the space within which the bearing is placed.

TAPERED ROLLER BEARINGS

Tapered roller bearings, employing rollers made in the form of the frustum of a cone, have the advantage over other types of roller bearings that they are adjustable for wear by lateral movement of the races, but in this case the same objection holds that holds against adjustable ball bearings—that the loaded side of the non-rotating race wears faster than any other part of the bearing and this causes a flattening of one side of the proper circle of travel. In well designed roller bearings of good material this flattening does not occur at a very rapid rate, so it is not necessarily inconsistent with long life, but it does make practically useless the provision for adjustment except as this is found advantageous in the original assembling.

Roller bearings, like ball bearings, must be

made of high-grade steel—preferably alloy steel, though carbon steels often are made to serve the purpose.

PLAIN BEARINGS

Plain bearings are the earliest of all types and in their best forms still possess important applications, their greatest advantage aside from their cheapness being the requirement of smaller circumferential (though greater lateral) space for a given load than is necessary with ball or roller bearings.

When made of suitable materials, finished to insure distribution of the load over the entire bearing surfaces and provided with sufficient and unfailing lubrication, plain bearings are serviceable and long-lived, and capable of operation without undue friction loss.

PLAIN BEARING MATERIALS

A wide range of different metals is suitable for plain bearings, one surface of which usually is that of the shaft itself. In most plain-bearing mechanisms the combination is a steel shaft running in contact with some other metal.

Steel as a material for plain-bearing surfaces is much better than is commonly supposed. There is in fact little in the whole range of engineering experience or knowledge to condemn the use of steel against steel, though it is essential that this combination of bearing surfaces be exceptionally well finished and perfectly lubricated if heating,

with consequent wear and "seizing", are to be avoided. Steel-to-steel permits higher loads to a given area than can be safely carried on any other materials.

Cast Iron as a material for bearing boxes is like steel a material of superior qualities, though it is little used for this purpose. It is, indeed, subject only to the twin disabilities of requiring exceptionally accurate finish and thoroughly adequate lubrication.

Bronzes, of copper and tin, and especially those alloys in which the tin component rises very high, with possibly some admixture of antimony, lead, or other fusible metals, are widely favored as a material for plain bearings.

Brasses, through a wide range of common alloys, possess many of the same bearing qualities as the bronzes.

Babbitt, an alloy of tin, lead, and antimony, in proportions that vary somewhat with the ideas of different manufacturers, is perhaps the most extensively-used and generally-serviceable plain-bearing material known. In its best qualities it reduces sliding friction almost to its lowest terms, besides which it possesses the advantage, not possessed by brasses and bronzes, of melting out if the bearing overheats through inadequate lubrication, thus avoiding the injury to the shaft which is certain to ensue when a brass or bronze bearing seizes. Babbitt requires, however, larger areas for given loads than are found sufficient for plain bearings of harder metals.

Graphite, in the form of compressed bushings surrounding a shaft, is under reasonable loads much more durable than would be imagined, and has the advantage of operating without lubrication. Bearings of this type are much used for trolley wheels in street-railway practise.

Wood, especially exceedingly hard wood, such as lignum vitae, boxwood, etc., is not without merit for plain-bearing surfaces in certain situations. The thrust blocks for taking the propeller thrust in motor boats and even in large steam vessels often are made of lignum vitae, lubricated with water, such construction proving a means of escaping the problems of rusting and leakage that are likely to appear when it is attempted to use bearings of other types and keep them supplied with oil.

Vulcanized Fiber makes a fair bearing material when provided in sufficient area and properly lubricated. In at least one instance of a supposedly well designed modern automobile fiber thrust bearings are used behind the bevel gears communicating with the final drive to the rear axle.

FINISH OF PLAIN BEARINGS

Of fundamental importance in the successful use of plain bearings is the accuracy of finish, which is second in importance only to the matters of proper material and sufficient size.

Areas of plain bearings usually are figured on the basis of the "projected area", as suggested by the dotted rectangle $a b c d$, Figure 154, this rec-

tangle being equivalent to a cross section of the center of the shaft within the bearing. The projected area must be of sufficient surface to carry the load considered permissible with the type of bearing material used. For long-lived babbitt bearings the load per square inch of projected area should not materially exceed forty pounds. With steel-bushed piston-pin bearings the load may run as high as eight hundred pounds to the square inch, though such loading does not prove conducive to slow wear and long life.

Scraping plain bearings is necessary in all cases where babbitt, bronze, brass, or similar materials are used. It is a means of giving a more perfect fit to the shaft than is possible by mere turning or reaming, and in the machine shop is technically known as "spotting in", from the fact that the shaft is tested in the bearing many times in the course of the operation, being coated after each scraping with a light wash of Prussian blue, which rubs off on the high spots in the bearing and thus indicates the places that require to be scraped down. Commencing with a babbitt bearing freshly cast and reamed, and contacting with the shaft at only four or five high spots, a good workman will carry this process of spotting-in a bearing until the test with the Prussian blue coating shows an great number of minute, closely-spaced high spots, indicating so even a distribution of the load over

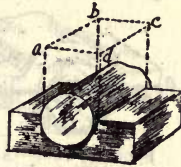

FIGURE 154.—
Projected Area of
Plain Bearing.

the entire bearing surface that wear can be counted upon to result with almost perfect uniformity.



FIGURE 155.—Adjustment of Plain Bearing. To tighten the bearing one or more of the thin liners of sheet metal at *a a* are removed.

Adjustment of plain bearings is generally effected by placing in or removing from the space *a a*, Figure 155, between the two bearing cups, "shims" of thin sheet metal.

The lubrication of a plain bearing must be well provided for, and is usually facilitated by grooving and drilling the bearing surfaces to spread the lubricant.

MISCELLANEOUS BEARINGS

Cone bearings, of the type illustrated in Figure 156, are much used in very light machinery generally and in delicate instruments, in which they prove light-running, fairly durable, and especially meritorious in that they permit such close adjustment as practically to eliminate all end movement from the shaft.

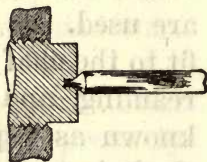

FIGURE 156.—Cone Bearing.

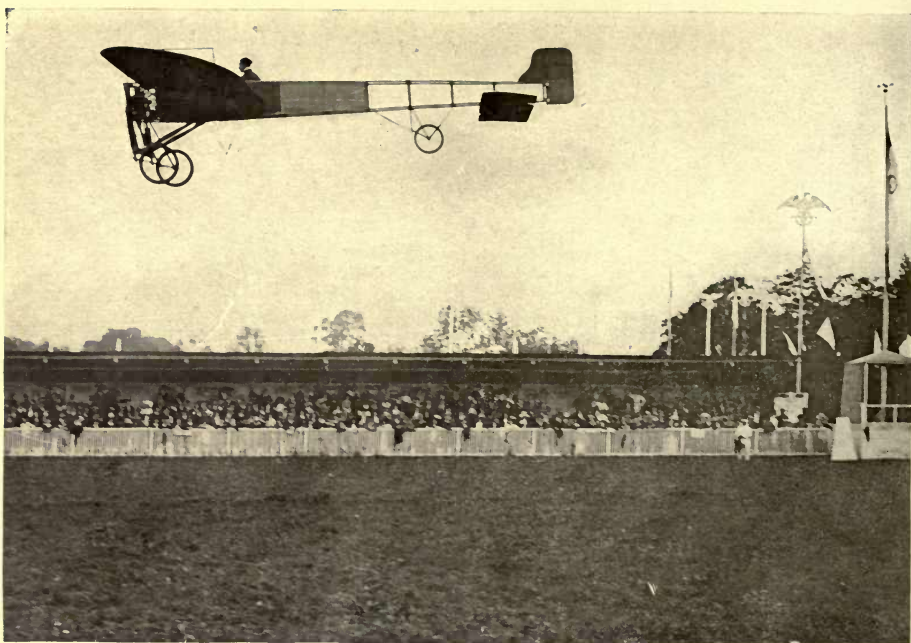

FIGURE 157.—Bleriot XI in Flight. This is the monoplane that crossed the English Channel.

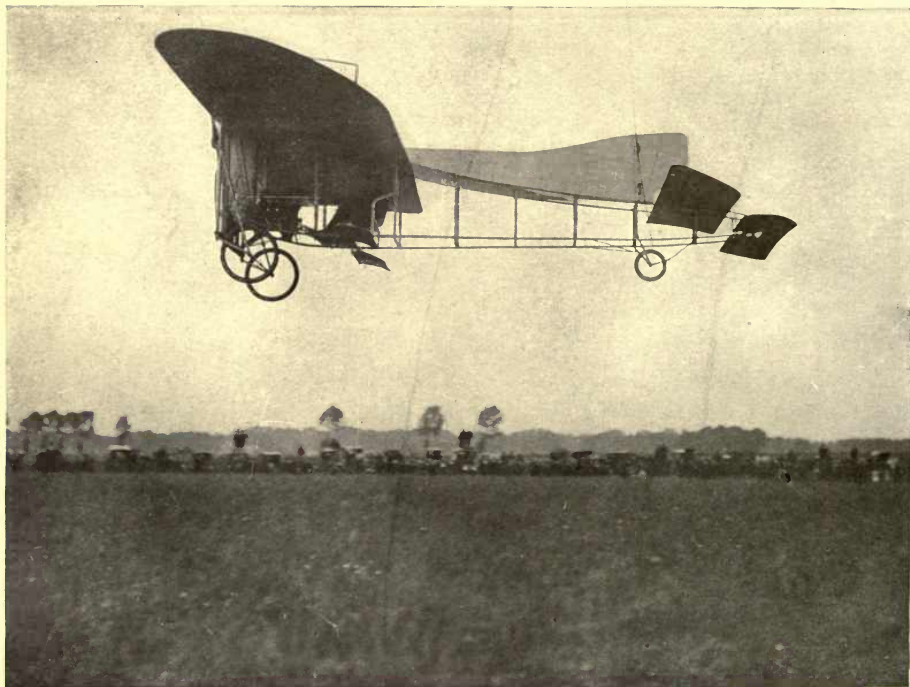

FIGURE 158.—Bleriot XII in Flight. This monoplane carries three passengers.

CHAPTER NINE

LUBRICATION

For mechanisms that must be quite light and yet subjected to a maximum possible duty, as is the case with practically every element of the power plant of a flying machine, it is a most pressing necessity that constant and adequate lubrication be automatically provided for every bearing, so that unflinching functioning is reasonably assured with a minimum of attention.

Haphazard methods of lubrication, which can be made to serve in automobiles and other mechanisms, should under no circumstances be tolerated in the design of an aeronautical power plant, in which the lubrication must be regarded as one of the most important elements of the whole device and arranged for on a correspondingly adequate basis.

SPLASH LUBRICATION

Splash lubrication, in which the oil is contained in a reservoir or pit adjacent to the surfaces to be lubricated, and splashed thereon by the movement of parts, is a common and very successful method of lubricating certain types of machinery, being most particularly applicable to the piston and cylinder walls of internal-combustion engines, enclosed gears, etc.

In many well-known types of automobile engines the connecting-rod and crankshaft bearings are lubricated by the periodic dip of the big end of the connecting rod into oil maintained at a constant level in the bottom of the crankcase, while in at least one well-known make a trough-like groove kept full by the splash from the connecting-rod, and located around the lower end of a cylinder so that the edge of the piston dips into it at the bottom of each stroke, is found to render the lubrication of the cylinder walls more positive than when dependence is placed solely upon the splash.

Spoon-like extensions from the lower ends of connecting rods, communicating with both crank-pin and piston-pin bearings, are in some circumstances found to distribute the oil better than is the case with most splash systems.

It is a merit of splash lubrication that it automatically stops and starts with stopping and starting of the mechanism, and thus is always fairly dependable, but it has the fundamental fault that it is a system of re-using the lubricant, the oil being supplied in measured charges of considerable quantity and utilized through a period of progressive deterioration. When it no longer serves its purpose it is replaced or admixed with fresh oil.

RING AND CHAIN OILERS

Small rings or chains hanging upon a shaft and dipping into small oil pits placed at suitable points constitute a very reliable means of splashing or

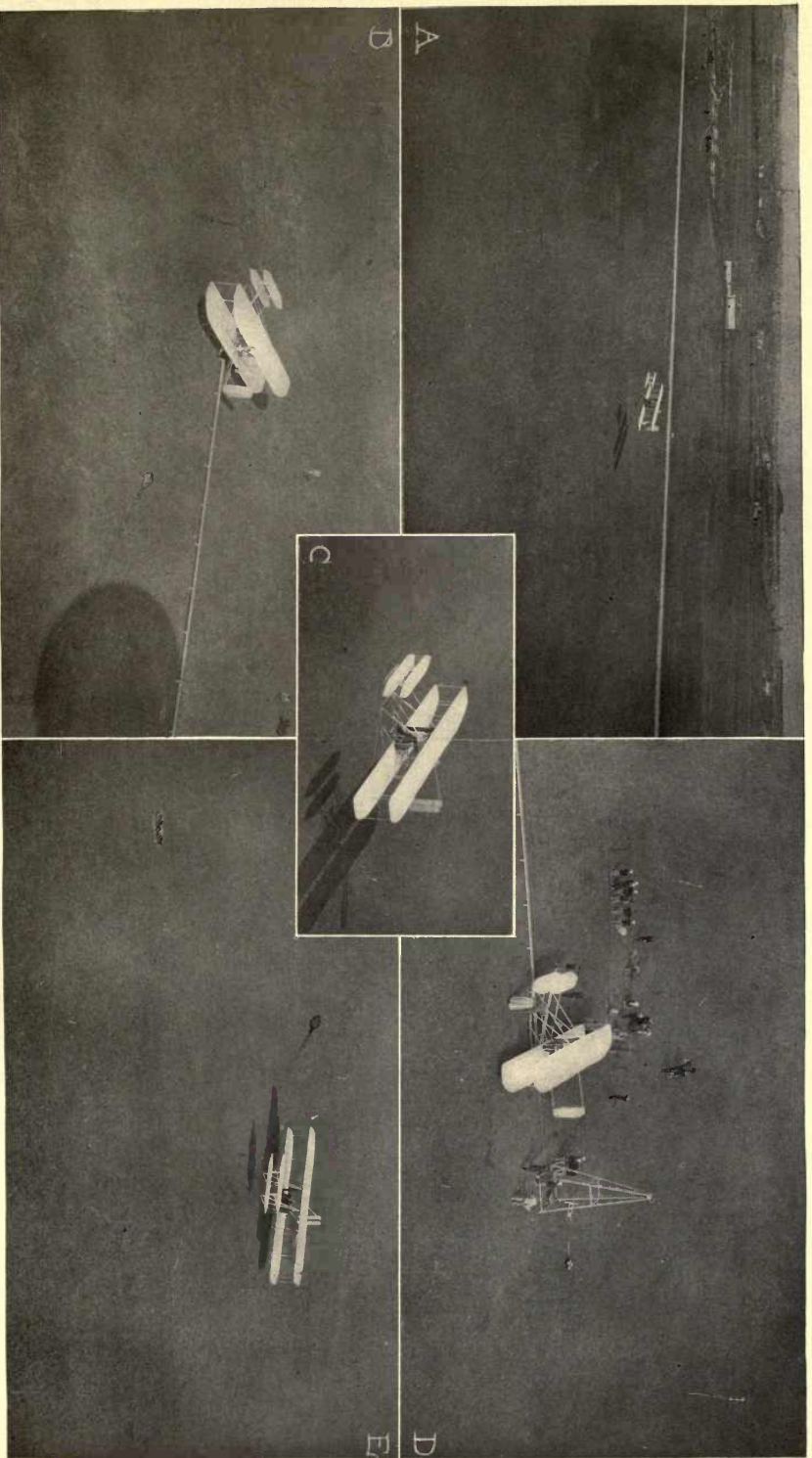

FIGURE 161.—Wright Biplane Starting and in Flight. This remarkable series of photographs, which were taken from a balloon at Rheims, France, in August, 1909, besides showing how the Wright machine is started also afford a most accurate idea of the close-to-the ground flight of which it is capable. The machine is shown ready to start at *D*, just leaving the starting rail at *B*, and in flight at *A*, *C*, and *E*.



taking up a small but steady flow of oil to find its way into the adjacent bearings.

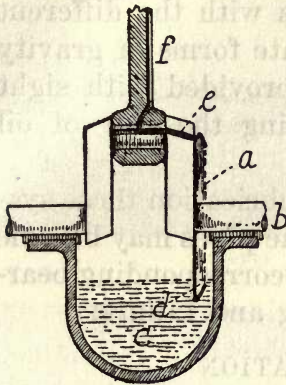

FIGURE 159.—Ring Oiler on Crankshaft. The ring *a*, by dipping into *c*, picks up a small quantity of oil in its grooved edge *d*, in which it is held by the rotation of the crankshaft *b* until it is thrown centrifugally through the hole *e* to the crankpin bearing, whence it finds its way by the pipe *f* to the piston-pin bearing.

Another type of ring oiler, much used for the lubrication of crankpins, is that pictured in Figure 159, in which *a* is the ring, fastened to the shaft *b* and dipping below the oil *c*, so that oil flowing into the groove *d* is there held centrifugally until it escapes through the hole *e*, connecting with the hollow pin *f*.

GRAVITY LUBRICATION

Gravity lubrication, in which the flow of oil is maintained through communicat-

ing pipes from a tank located above the bearing or bearings, is exceedingly simple and possesses the virtue of always supplying fresh oil to the wearing surfaces, the oil as fast as it is used draining away, directly to the ground or into a sump or pan which can be emptied at intervals.

OIL CUPS

Oil cups, placed directly over the bearings they feed, are probably the simplest and commonest form of gravity lubrication. They usually are provided with some sort of adjustable drip feed, with a sight glass to inspect the rate of drip.

RESERVOIR SYSTEMS

Reservoir systems, with a single reservoir connected by a plurality of leads with the different bearings, are the most elaborate forms of gravity lubrication, and usually are provided with sight feeds and means for regulating the flow of oil through the different pipes.

Like all forms of gravity lubrication these systems have the objection that the pipes may become clogged and thus cease to feed corresponding bearings, with prompt overheating and failure.

FORCED LUBRICATION

Forced lubrication, by which the lubricant is sent to the bearings under pressure, is in its best forms the most reliable and meritorious system possible, because, while possessing the reliability of splash lubrication, it is a system of feeding fresh lubricant under conditions that may be so arranged as to avoid the possibility of stopped pipes.

PRESSURE FEED

One of the simplest forms of forced lubrication involves the use of a single reservoir with a number of leads, much the same as in the just-described reservoir system for gravity feeding but with this difference—that air or exhaust-gas pressure is maintained to deliver the lubricant, so as to afford greater assurance of positive feeding than is had with gravity alone. Nevertheless, stoppage of one of a number of leads is likely to go undetected, the pressure being relieved by a greater flow of oil through other leads.

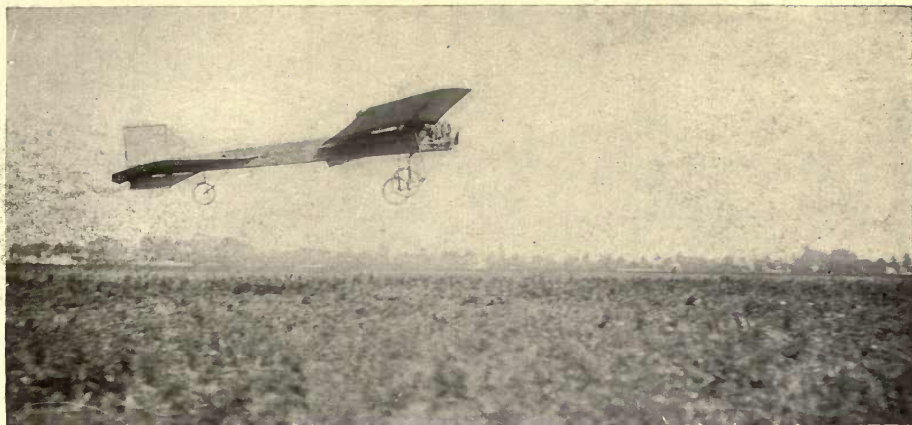

FIGURE 162.—Koechlin Monoplane in Flight.

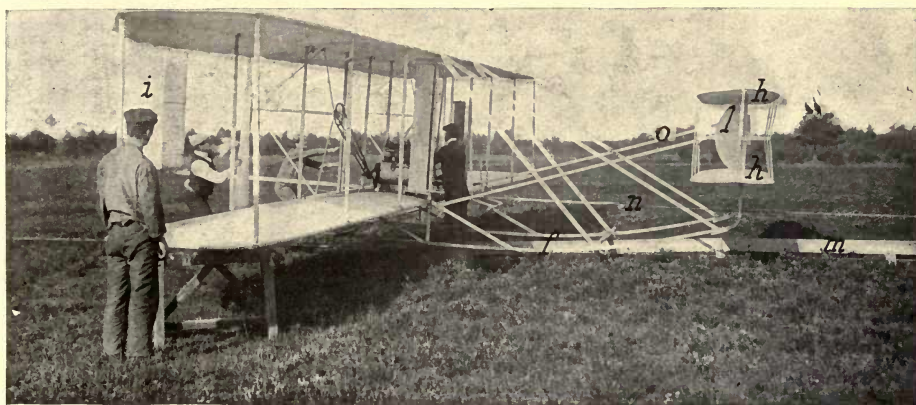

FIGURE 163.—Wright Machine on Starting Rail. The starting rail is at *m*, *n* is the connection of the rope by which the starting impulse is given, *f* are the runners, *h* is the elevator, *o* is the elevator control rod, *i* is the rudder, and *l* is one of the steadying planes peculiar to this machine.

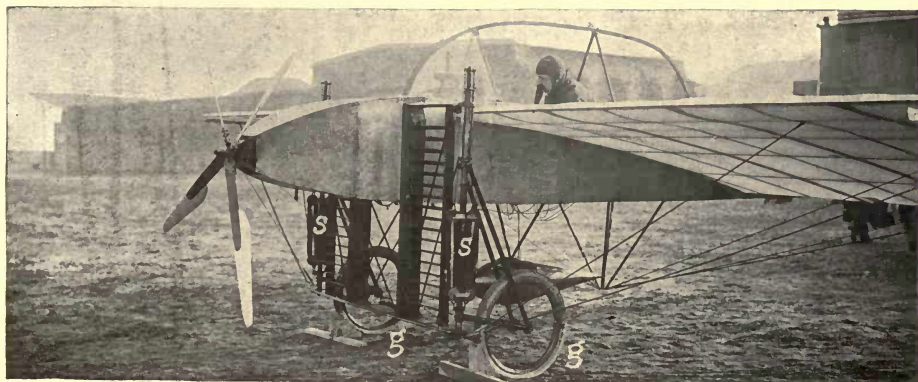

FIGURE 164.—Bleriot Alighting Gear. The wheels *g g*, upon striking the ground, are cushioned in their upward movement by the rubber springs *s s*.

SINGLE PUMPS

Single pumps for forcing a continuous flow of oil over bearings or through systems of leads, the oil usually being pumped from a sump or pit in the crankcase or the like, are found very satisfactory for engine lubrication, though as a special safeguard against breakdown the circulating system should have a loop with a glass sight feed placed within view of the operator.

MULTIPLE PUMPS

One of the most reliable of all lubricating systems is that in which oil is sent from a reservoir through a plurality of leads, one to each bearing, by a corresponding plurality of small individual pumps each admitting of adjustment to vary the individual feed and capable of working against high enough pressure to insure the clearing out of any possible obstruction that may pass into the pipes. Such systems of forced lubrication are extensively used in the

power plants of the best automobiles, and for flying-machine power plants prove similarly superior.

A typical force-feed lubricator is illustrated in Figure 160, in which *a* is the reservoir, *b b b* are the leads, *c c c* are adjustments, and *d d d* are the individual sight feeds by means of which imperfect operation or failure can be instantly detected and remedied.

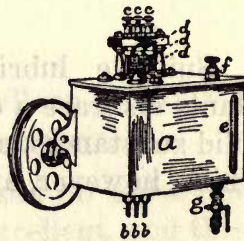

FIGURE 160. — Force-Feed Lubricator. The pipes leading to the different bearings are at *b b b*, adjustment of the flow through these pipes is by the thumbscrews *c c c*, and the rate of the flow is shown by the sight feeds *ddd*.

GREASE CUPS

Grease cups, while similar to oil cups, are properly systems of forced lubrication in that they are filled with grease or non-fluid oil capable of being forced out by screwing down the top. Grease cups are very reliable because while designed primarily to have occasional attention they will nevertheless feed automatically by gravity in the case of an overheated bearing, which thus may take care of itself by melting the contents of the grease cup and so causing them to flow down without forcing.

LUBRICANTS

Suitable lubricants for aeronautical power plants embrace a considerable range of liquid and solid substances, a comparatively small number of which, however, are found really superior.

MINERAL OILS

Mineral oils, derived from the distillation of petroleum, are almost universally used for the lubrication of the heating surfaces in gas engines, being capable of withstanding temperatures as high as 600° F. and 800° F. without giving off ignitable or combustible vapors. Mineral oils also are suitable for the lubrication of gears, plain bearings, etc.

Vaseline is a petroleum grease that, with or without admixture, is found exceedingly valuable for lubricating gears, ball bearings, etc.

Miscellaneous mineral lubricants are used in great number, in a great variety of combinations,

and it is unfortunately a fact that the composition of many of these is dictated by commercial rather than by technical requirements, for which reason it behooves the user of a high-grade aeronautical engine, ball bearings, or other delicate mechanism, to use the most critical judgment in discriminating between the different preparations marketed for the purpose, altogether too many of which are very far from being of the highest quality. Probably the best policy is to patronize only the most reputable dealers, whose integrity and commodities are both to be relied upon.

VEGETABLE OILS

Some vegetable oils are of excellent quality for the lubrication of some types of bearings.

Castor Oil, for light spindles and for axles not revolving at too high speeds, is excellent, and this oil has been used with considerable success, with or without an admixture of mineral oil, for the lubrication of the close-fitting pistons in racing automobile engines. Used for this purpose it tends to cause a considerable amount of carbonization, but if fed in sufficient quantities it invariably relieves friction and facilitates smooth operation in a degree almost impossible to attain with even the lightest and best of mineral oils.

Olive Oil, suitably treated and refined, is almost absolutely non-drying, for which reason it is a preferred ingredient in oils for fine watches and delicate instruments.

ANIMAL OILS

Sperm Oil, from the blubber of the sperm whale, is considered by mechanical experts to be the best of all lubricants for light machinery, such as sewing machines, phonographs, etc., and undoubtedly will find more or less application in aeronautical mechanisms.

Tallow, while an engineer of experience might first be inclined to regard it as totally unsuitable for the lubrication of heated surfaces, is nevertheless found to be the only satisfactory lubricant for the cylinders and pistons used in type-casting machines for pumping molten type metal. This fact might seem to indicate a possibility for it even in the field of internal-combustion engine lubrication. As a component of various greases for gear and other lubrication, tallow fills a recognized place. Most of the solid compounds used for the lubrication of bicycle and automobile chains are an admixture of tallow and graphite, and are best applied by being melted, and the chain soaked in the fluid.

MISCELLANEOUS LUBRICANTS

In this category fall such solids as finely-divided graphite, mica, asbestos, and plumbago, all of which tend to reduce friction by filling up the minute inequalities that can be microscopically proved to exist in the most perfectly finished surfaces. Graphite is generally considered far superior to the others.

Water has been mentioned (see Page 344) as a lubricant for wood thrust bearings. Soapsuds is

recognized by engineers to be without a superior for cooling and lubricating certain types of plain bearings under certain peculiar conditions of overheating.

Kerosene, while not commonly regarded as a lubricant, has considerable lubricating qualities, and for light shafts and spindles can be made to serve the purpose very effectively. Even in gas engines periodic dosings of kerosene, preferably fed through the carbureter, are with automobile experts a recognized means of limbering up the mechanism, serving the double purpose of thinning used oil to a better lubricating body and of cutting deposits of carbon.

CHAPTER TEN

STARTING AND ALIGHTING

The problems of starting and alighting with flying machines may be considered to apply chiefly to flying machines of the aeroplane type, since balloons, helicopters, and ornithopters do not require special starting or alighting appliances.

But for the aeroplane, which flies by means closely analogous to the means employed by soaring birds, the necessity for some sort of starting and alighting gear or device is apparent. Even the birds do not escape this necessity, small birds making their initial rise into the air by one or more hops, and larger birds being compelled to drop from an eminence or to make a considerable run on the ground—it being an interesting but well established fact that the condor and the California vulture, the largest flying birds known, can be safely imprisoned in a small pen, open at the top, but with sides sufficiently high to require a rather steep angle of ascent.

For these reasons, already suggested in the introduction to this work (see Page 35), as the successful flying machine comes more and more into practical use it will reasonably come to be regarded quite natural for aerial vehicles to require for their utilization the provision of special landing places

and starting devices, just as it is commonplace for docks to be provided for water craft and stations for railway trains. Also, as is remarked on Page 35, it probably is a wholly erroneous idea of the factors of the situation to suppose that aeroplanes are proposed or will be used for urban travel, such as must require their starting from or alighting in the streets of cities, or even the roofs of buildings—though it is rather more probable that the latter may in time come to be utilized to a limited extent. But a more likely provision will be that of large cleared areas in the suburbs of towns, permitting suburban flying between these areas and leaving the problems of strictly urban transportation to other than aerial vehicles.

STARTING DEVICES

A very logical though not closely-drawn distinction can be made between starting devices and alighting gears, the first being not necessarily, at any rate in all its elements, a permanent part of an aerial vehicle, whereas an alighting gear is necessarily a part of the machine. The distinction is complicated, however, by the fact that in some machines the same wheels or other devices serve both as starting and alighting gears.

For these reasons it will not be attempted herein to draw the lines between classifications too closely, it being more important to give proper consideration to the different devices that have been found most satisfactory and that appear the

most promising for the effective launching and safe landing of practical air craft.

WHEELS

The simplest and most widely used starting device is the wheel, the Santos-Dumont, Voisin, Curtiss, Farman, R. E. P., Antoinette, Bleriot, and many other successful modern biplanes and monoplanes all being provided with bicycle or motorcycle wheels, which often are used also as alighting gears—to which end they are almost without exception fitted with spring and cushioning devices to take up the shock of an abrupt encounter with the earth.

RAILS

The use of rails to provide smooth tracks for launching aeroplanes probably originated with Henson in 1842, at which time he employed them

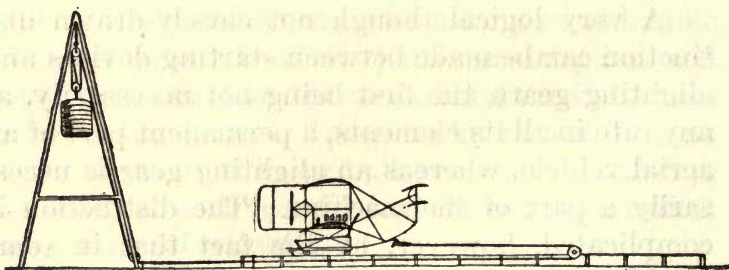

FIGURE 165.—Wright Starting System.

in an attempt to launch the machine referred to on Page 155. Rails were then used by Maxim, as a course upon which to start and test his wonderful but unsuccessful machine (described on Page 156), which lifted itself on July 31, 1894. The next use

of rails was in the catapult-like launching device employed by Langley in his trials over the Potomac River during the years 1896 to 1903, inclusive.

The most modern and practically the only successful use of rail launching devices is in conjunction with the modern Wright machines, which are run an initial distance of from 70 to 125 feet, balanced on a tiny two-wheeled truck, on a single crude wooden rail, about eight inches high and faced with strap iron. This arrangement is more fully described on Page 362, and is illustrated in Figures 163, 165, and 166.

FLOATS

Floats, in the form of boat-like hulls, have been to some extent used in experimenting with aeroplanes over water surfaces, and appear to present possibilities of practical development. The use of light racing shells, which are capable of carrying from five to nine men totaling from 800 to 1,600 pounds, and which weigh from thirty to fifty pounds, appears to be the most promising line of development, though waterproof fabric floats can be made exceedingly light for a given sustaining effect.

Undoubtedly, just so soon as some means is devised of permitting aeroplanes to start from and alight upon water surfaces without exterior aid, trans-aquatic journeys will become practicable with almost absolute safety even with present machines. The hydroplane type of boat hull, which skims over the surface of the water rather

than plowing through it, in many respects appears to be the ideal form of float for water-traversing aeroplanes.

RUNNERS

Runners, besides having been used successfully by the Wrights in starting over wet grass under the thrust of the propellers, also have been used in starting from ice—frozen lake surfaces—in the work of the Aerial Experiment Association. Their most conspicuous merits, however, are as alighting rather than as starting devices. (See Page 370.)

THE STARTING IMPULSE

It being necessary with most modern aeroplanes to make a shorter or longer run on the ground or on rails before sufficient sustentation is secured to rise in the air, the question of securing the necessary starting impulse becomes one of some moment, and it is evident at the outset that the solution can be reached in any one of a number of different ways.

To maintain an aeroplane in flight no very great thrust or pull, as the case may be, is required, the amount of this thrust or pull being probably from 100 pounds to 250 pounds in the different machines that have proved most successful so far—though there is reason for expecting that much lower tractive forces will suffice as head and aerodynamic resistances come to be lowered—but for securing the rapid rate of acceleration required to reach a sustaining speed with only a short run, a much greater thrust is essential.

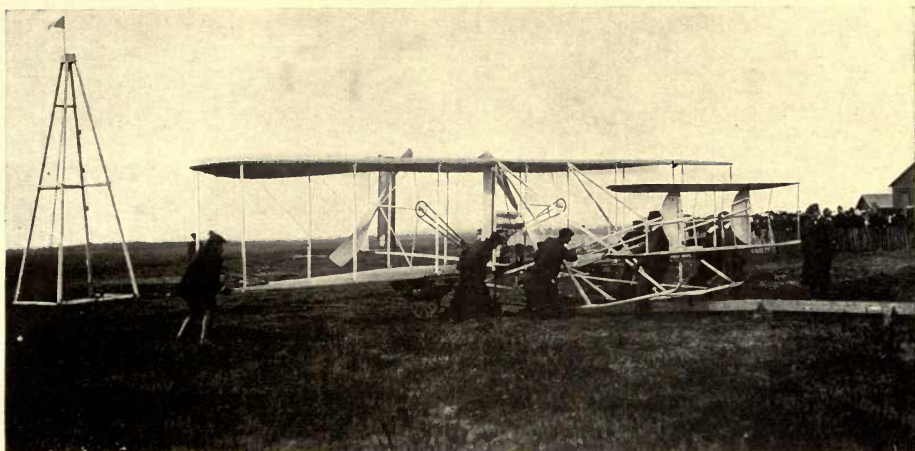

FIGURE 166.—Wright Machine on Starting Rail, with Starting Derrick in the Background

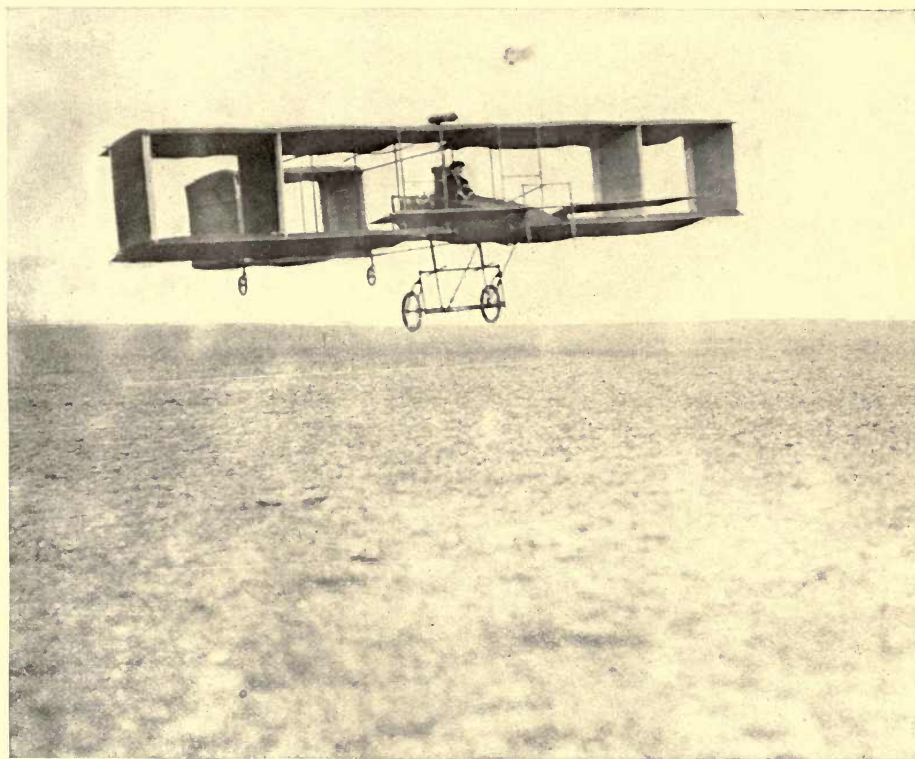

FIGURE 168.—Rougier's Voisin Rising from Starting Ground.

Propeller Thrust, upon which dependence is placed to maintain modern aeroplanes in motion, also is used in most of those with wheeled starting and alighting gears to produce the initial run on the ground, but in most of the machines to which this method is applied it has not been found possible to get into the air with runs of less than from 200 to 400 feet over fairly good ground. This distance can be kept to a minimum by holding the machine until the propeller is at full speed, either by a brake or by the efforts of assistants. Another possible scheme might be the use of a sprag-like claw to catch in the ground, until it were desired to release the machine. In Figure 164 it will be noted that the wheels of the machine are blocked.

Starting solely by its thrust, the propellers have even been employed successfully for starting with the Wright machine, without the rail, the aeroplane being simply slid on its runners over wet grass, but in this case an initial run of five hundred feet was found necessary before the machine altogether left the ground. In this connection, however, it is interesting to reflect that no such duty devolves upon the propeller as would be involved in dragging the full weight of the machine over the ground for the entire distance, with it resting solidly upon its runners. The reason for this is that as soon as any headway whatever is attained, there is a corresponding measure of lift which proportionately reduces the weight resting upon the runners—the weight thus supported gradually reducing from the entire weight of the

vehicle at the start, to an infinitely small percentage of this just before lifting from the ground.

An advantage of the propeller in affording the starting impulse is that its thrust is highest when the vehicle speed is lowest—at which time the need for high thrust is greatest.

Dropped Weights, operated in small starting derricks, the *pylons* of the French, are in some respects an excellent means of securing the initial impulse, though they are so far employed only with the Wright machines. In the Wright starting device, shown in Figures 165 and 166, the tower is an extremely simple and inexpensive one of pyramidal form, built of four main timbers each about twenty-five feet long and two inches square, lightly braced by three horizontal frames and diagonal wire stays. The weight, about fourteen hundred pounds of cast iron disks (a can of earth or stone has been suggested as perfectly suitable for emergency use) is attached to one of two pulley blocks, the other of which is suspended in the apex of the tower, the rope passing around the sheaves a sufficient number of times to provide a three-to-one relation between the movement of the weight and the movement of the aeroplane along the starting rail.

Disregarding friction losses in the sheaves, the rope, which passes down to the bottom of the tower, forward to and around a pulley towards the front end of the rail, and thence back to the aeroplane, exerts a pull of about 450 pounds, with a rate of acceleration about in relation to the law

of falling bodies, which of course governs the fall of the weight. To the pull of the weight is added the thrust of the propellers, which are set in motion before the machine is released for its start along the rail. The propellers take up the entire work of propelling the machine when some fifty or sixty feet of the rail are traversed, the weight not accelerating the machine clear to the end of the rail.

At the limit of the weight-impelled portion of its travel along the rail, the rope automatically unhooks from its attachment to the machine, which promptly thereafter lifts off the truck on which it has been mounted and at once commences free flight.

Winding Drums, as a substitute for the dropped-weight system of starting, have been proposed by a number of experimenters. In a patent issued to Octave Chanute the principle is claimed of locating a power-driven winding drum on a conveniently placed truck, this drum connecting by a cable with the aeroplane in such manner that the cable connections can be thrown off by the operator just before or after the machine leaves the ground.

In a starting device invented by the writer the principle is claimed of locating a winding drum on the aeroplane as at *a*, Figure 167, a light wire cable running from this drum to a stake driven in the ground. By providing the end of the cable with a ball-like or flat end fixture, arranged so that it will disengage automatically from the spherically-

cupped or otherwise peculiarly-formed head of the stake as soon as it pulls up at a vertical enough angle from the vehicle passing over the latter, a very effective means of starting is provided. The writer prefers to make the drum of a varying diameter from one end to the other so that the desired acceleration is secured without variation

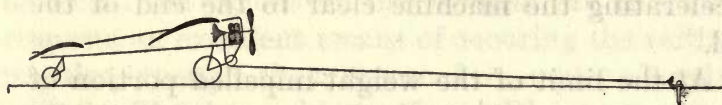

FIGURE 167.—Starting by Rope Attached to Stake and Wound in on Drum. The drum, which may be friction-driven from the engine, winds in the rope until the machine is nearly over the stake. Provision can be made for automatic cessation of the winding at this point, so that the rope frees itself from the stake as the machine passes over it. By making the drum of tapered instead of cylindrical form, proper acceleration is readily provided.

in engine speed. Also, it is preferred to connect the drum with the shaft by a friction clutch, but many alternative constructions of course are possible. In this scheme of starting it is required to leave a stake in the ground each time a start is made, but, the stakes being made very light, preferably of steel tubing, the necessity of carrying along a few is not a serious objection, especially when it is considered that even in a machine regularly equipped with such a starting device it would be brought into use only when other methods of starting could not be employed.

Inclined Surfaces, for starting aeroplanes by the action of gravity, have been used most successfully by Lilienthal, the Wrights, and some others. They constitute one of the simplest of all possible means of starting and under proper conditions are very effective. The utilization of natu-

rally sloping ground, either alone or in conjunction with any established starting means, greatly facilitates starting. The Wrights usually endeavor to lay their starting rail down hill, direction of the wind permitting, and the same is true of the runs made by other experimenters on wheeled-starting devices.

LAUNCHING VEHICLES

This term is applied by the writer to a class of starting mechanisms that have been more extensively suggested than experimented with. By it it is meant to refer to such possible methods of starting as by mounting an aeroplane on an automobile, rail vehicle, or water craft, and making the initial run with this vehicle, with the idea that the aeroplane will rise into free flight as soon as sufficient speed is reached.

Automobiles might easily be built in a modified form suitable for the purpose just suggested—with a rather simple car, capable of the necessary speed on good ground and provided with a substantial framework rising above the head of the driver, upon which to rest the aeroplane without any attachment other than the use of such lugs as might be necessary to keep the aeroplane from sliding off backwards. With such a construction it should be an easy matter to start an aeroplane in the air by a short run over any suitable surface.

Railway Cars of a special type—possibly small gasoline or electrically-propelled flat cars—might readily be made to serve the same purpose, though in this case the necessity for a track is an objection

because it is desirable always to have the aeroplane face the wind when leaving the ground.

Boats, in several types of motor launches, torpedo-boats and torpedo-boat destroyers, and fast cruisers and battleships, possess established speeds well in excess of the minimum flying speeds of several successful modern aeroplanes. Consequently such water craft, with a perfectly clear deck forward upon which to mount suitably-designed aeroplanes, by running into the wind must constitute quite effective means of launching the aerial vehicles. Subsequent alighting upon the water would be perfectly safe with proper floats as alighting gears, while disappearing cranes would serve excellently to hoist the aeroplanes inboard for reprovisioning or restarting.

CLEARED AREAS

No matter which of the starting and landing methods so far considered is to come into ultimate prominence, it seems impossible ever to escape the superior desirability of cleared areas from which to start and upon which to alight. Moreover, such areas will hardly suffice if merely made long and comparatively narrow, as has been often suggested. Apparently they must be circular in form, so that alighting or starting in any direction will allow sufficient distance for necessary retarding or accelerating. A maximum of 500 feet would seem to be the distance suitable for most present-day machines, this distance in all directions calling for a cleared circular field of

about six acres. In case of such an area being bordered by trees or high buildings, such as might not be readily passed over at the steepest possible angle of ascent, it would be necessary to extend the space considerably beyond that actually required for the mere run on the ground. The possible limit required would be an area large enough to permit circling flight over it until sufficient height were attained to pass over the highest of adjacent obstacles. A Voisin aeroplane starting from such a field is shown in Figure 168.

FACING THE WIND

Facing the wind, while perhaps not an absolute necessity, certainly is a most desirable condition of starting with present types of machines. Obviously, a sustaining surface requiring a certain speed through the air before it can lift the machine from the ground, would when running with the wind afford less actual speed through the air than over the ground, requiring a consequently higher speed over the ground to secure the necessary speed through the air. On the other hand, travel against the wind adds substantially the speed of the wind to the ground speed of the vehicle, with the result of rendering starting in a moderate wind easier than in a calm. The only condition under which starting in the wind might be objectionable would be the existence of a gale greater in speed than the maximum flying speed of the aeroplane. This might cause the vehicle to be thrown backwards with more or less force against the ground or any neighboring obstacle.

A wind from one side is particularly objectionable in starting, as it tends to careen the machine over even before it is in flight, and therefore must inevitably result in disaster.

Of course, once flying is under way it is a comparatively simple matter to turn and travel in any direction—with the wind, against it, or across it.

LAUNCHING FROM HEIGHT

Dropping a machine from a height or launching it over the edge of a cliff or building bears a rather close resemblance to the means of starting employed by many birds, whose powers of flight are such that they unhesitatingly plunge from cliffs, trees, buildings, etc. In artificial constructions,

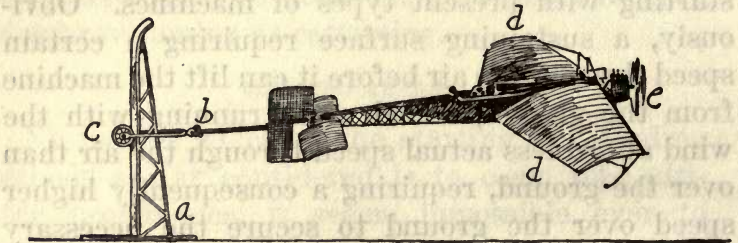

FIGURE 169.—Bleriot Starting Device. The aeroplane is hooked by the rope *b* to the pulley *c*, which runs along the rear edge of the pillar *a*. By starting the propeller the back draft of air thrown under the wings *d d* is expected to lift the machine until *c* runs off the top of *a*.

the only instance of the successful use of this scheme was its employment by Professor Montgomery in his experiments in California in 1905, in the course of which his wonderful glider was released with safety from balloons sent to heights as great as 4,000 feet. Of unsuccessful attempts at this sort of launching, possibly the most recent

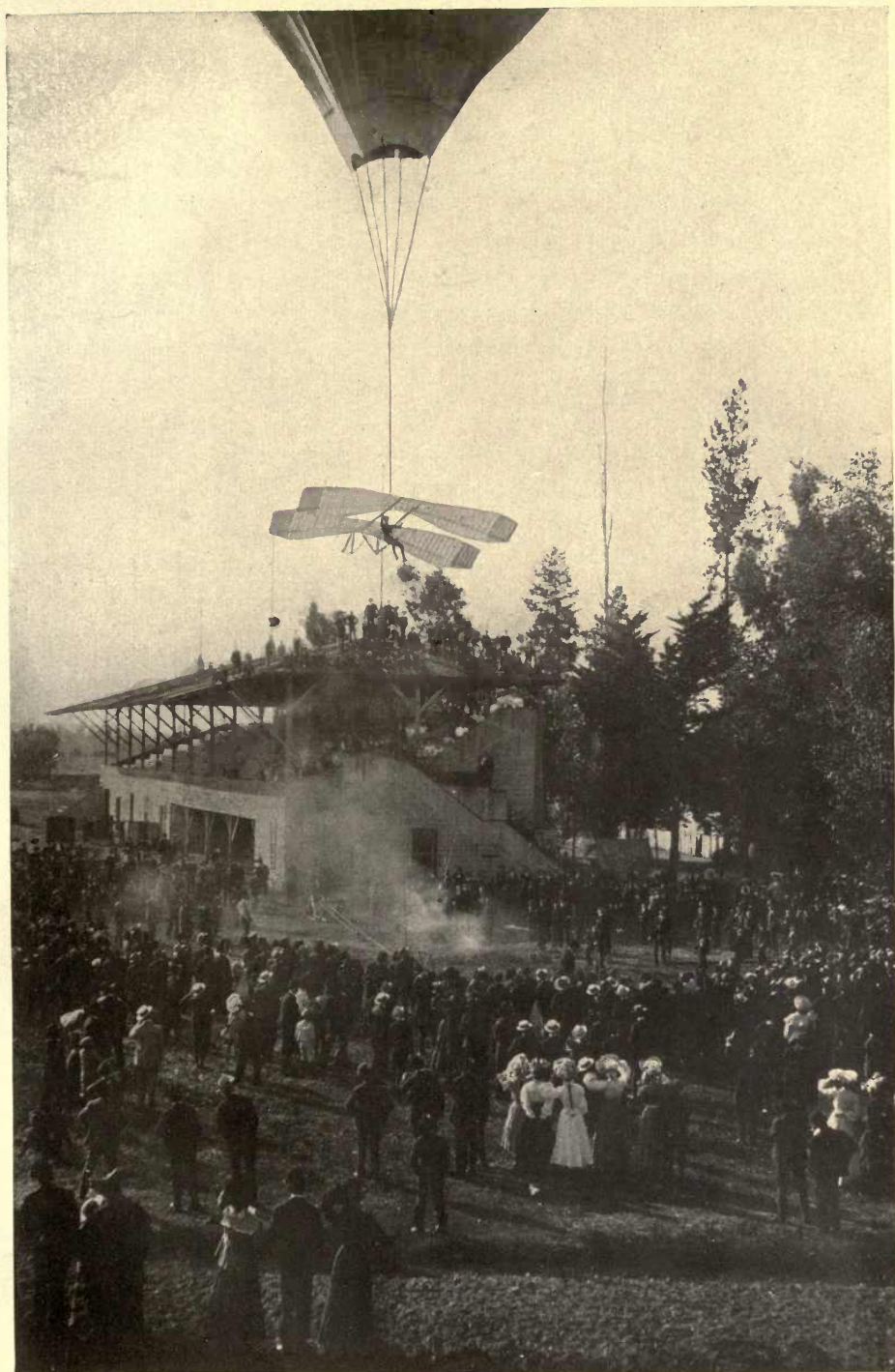

FIGURE 173.—Elevating Montgomery Aeroplane with a balloon, in California, in 1905.

was Langley's ill-fated launching of his full size machine from the top of a house boat over the Potomac River on December 8, 1903. Previous to these experiments history records various attempts of individuals whose efforts to navigate the air more than once involved leaps from cliffs and towers, as in the cases mentioned in Chapter 15. Practically all of these resulted in more or less serious mishap.

In gaging the practical merits of this scheme it always is to be considered that should an aerial vehicle be launched from a roof or tower, and subsequently prove to have anything seriously wrong with its sustaining elements, the consequence could scarcely fail to be a serious disaster. On the other hand, in launching from the ground, should the machine prove not to be in proper flying condition it would be likely simply to fail to go up.

ALIGHTING GEARS

Alighting gears, while in many machines identical with the starting means, are not so in all cases. Nevertheless, in practically all present-day aeroplanes that are started on wheels, the wheels also are used for alighting, being usually mounted on one sort or another of shock absorbers as has been already suggested on Page 358.

WHEELS

The alighting device of a typical modern aeroplane is very well illustrated in Figure 170. In this the long helical springs at *ss* take the shock

of alighting, the wheels *g g* swinging on the linkages.

The Bleriot alighting gear, shown in Figures 118, 164, and 171, is similar to the foregoing except in its pluralities of rubber bands are used in place of the helical springs, being found both lighter in weight and less likely to break for a given cushioning effect.

With wheels used as alighting gears, several experimenters have provided brakes to produce rapid retardation after touching the ground. Such a brake is a feature of the Curtiss machine. (See Figure 228 and Chapter 12.) Another unusual feature of the Curtiss running gear is the total absence of any sort of shock absorber.

RUNNERS

Runners for alighting possess the advantage over wheels that they will span inequalities of surface that must inevitably wreck a wheel, as is quite evident in Figure 163. They also constitute an effective brake that comes into perfectly gradual and most effective operation as soon as the weight of the vehicle commences to be sustained upon the ground.

FLOATS

As has already been suggested on Page 359, the use of floats for machines intended to fly over water possesses some merits. And, of course, any float that will suffice to hold a machine up well enough to make a start from the water must also serve very satisfactorily to alight upon. Wilbur

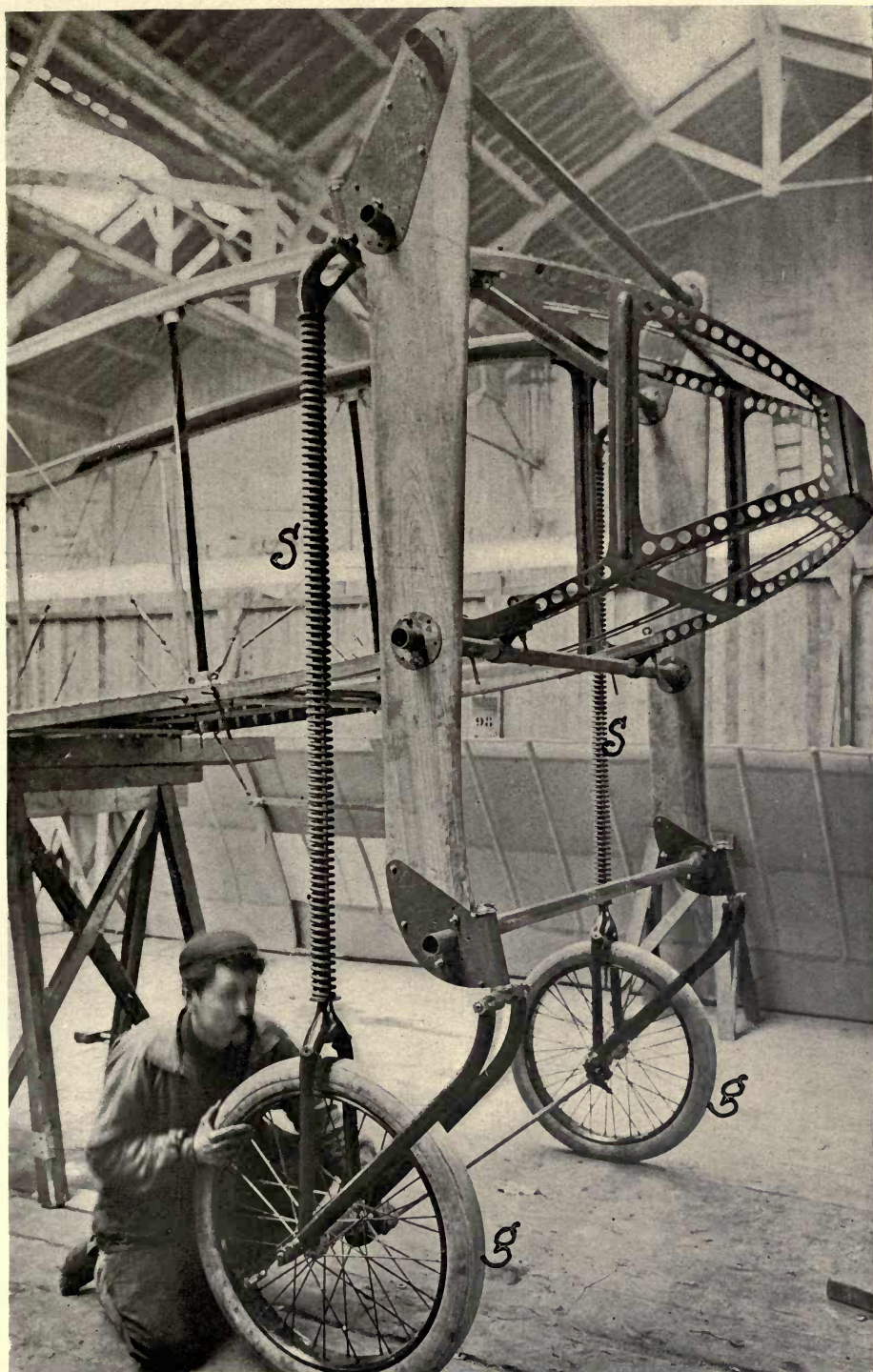

FIGURE 170.—Typical Alighting Gear. In this the upward swing of the wheels *g g* on their link connections is cushioned by the helical springs *s s*.

Wright's use of a canvas canoe hull attached to the understructure of his machine during his flights around New York during the Hudson-Fulton celebration is significant in this connection.

MISCELLANEOUS

Besides the more or less distinctly different types of starting and alighting gears so far tried, there appears to be considerable progress to be had from experiments with various combinations of differing individual elements.

For example, in Figure 174 there is shown the under construction of the recent Farman machines, in which the wheels *g g g g* are used for the starting run, while in alighting the wheels spring up above the runner level from the shock of contact, so that the runners come into play as brakes and protect the wheels from inequalities of surface.

Superior in many respects to the two foregoing would appear to be some more definite scheme of dropping and locking the runners below the wheel level and of raising them above it, as conditions of alighting or landing, respectively, might require.

In considering possible combinations of starting and alighting elements, it appears probable that in time there may even be developed starting and alighting gears capable of starting from or landing upon any reasonably clear space of land or water, without recourse to special constructions for special conditions.

CHAPTER ELEVEN

MATERIALS AND CONSTRUCTION

The questions of structural materials and methods of construction are among the most vital of all that the aeronautical engineer has to face. Every matter of safety and success depends directly upon the quality and reliability of the materials of which the machines are built, and the ways in which these materials are put together.

Fortunately the problem, while one of great difficulties, is also possessed of important compensating advantages. It is becoming more and more established that successful flying machines require the use of comparatively little metal, and especially of little metal of resistant qualities worked into intricate shapes. The result is that flying-machine construction, while often requiring considerable painstaking labor does not particularly require expensive facilities, and therefore stands open to a greater number of unhandicapped amateur experimenters than almost any other field of engineering research or industrial enterprise.

Necessarily, other equipment being equal, the engineers most certain to achieve success in pioneering this new field will be those who prove the most widely informed and resourceful. For these reasons at least a smattering of a great many

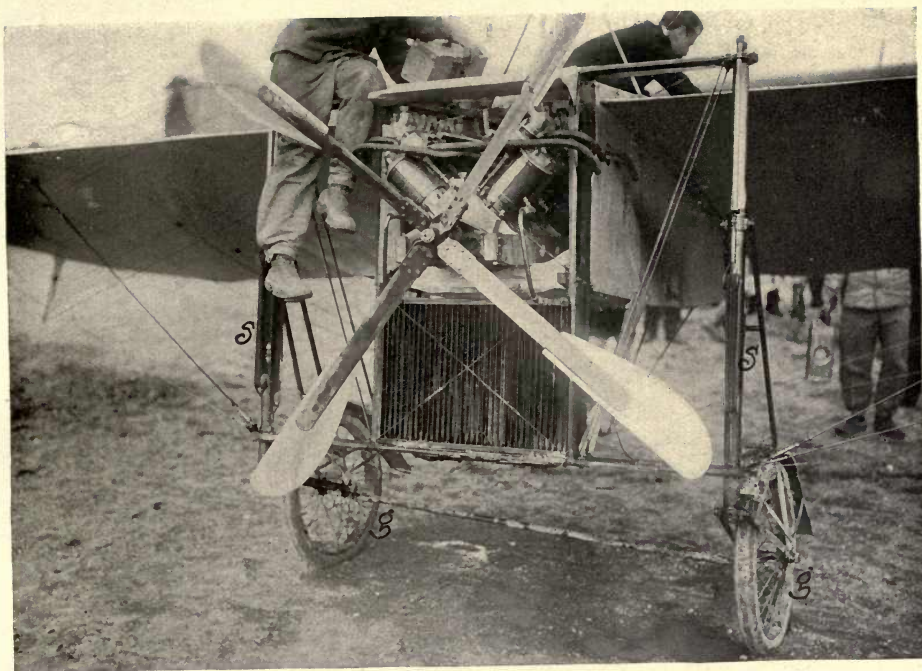

FIGURE 171.—Details of Bleriot Monoplane. This is one of the earlier machines of the “Bleriot XI” type, and is provided with an eight-cylinder, water-cooled motor, with radiator immediately beneath it. The wheels *g g* and the rubber springs *s s* are characteristic of the Bleriot alighting gear, but in the case of the latter the multiplication of the movement as shown in this view by passing over rollers has been abandoned.



FIGURE 172.—Alighting Gear of Paulhan's Voisin. The wheel *g* on the prow is a safeguard against undue forward inclination of the machine in landing.

different trades is likely to be prolific in suggested ways of accomplishing things.

Because of the great need for a comprehensive view of and assimilation from all fields of engineering, it seems proper here to call attention to various examples of construction that have been either overlooked or have failed to gain the consideration their merits demand. Certainly no worker in aeronautics can afford to be unfamiliar with the wonderfully light, strong, and durable sled and boat constructions that the Eskimo achieves with bits of wood, sinew lashings, and skin coverings; or with the almost perfect craftsmanship displayed in the manufacture of the primitive weapons of many savage races—not to forget the more enlightened workmanship of the modern bicycle or automobile builder.

WOODS

Not without a considerable basis of fact it has been asserted that the flying machines of the future will be built in the carpenter shops of the future, for wood is by far the most utilized material in all successful fliers. For wing bars and ribs, runners and running gears, frames, braces, and the like, wood seems as serviceable and indispensable as it is for the rims of bicycle wheels, besides which it is cheap and easily worked.

It is not generally appreciated, even by many engineers, that certain woods constitute almost the strongest, most reliable, and most durable of all

structural materials, the best qualities of selected timber being, weight for weight, close rivals in sheer strength—compressive, tensile, shearing, and even torsional—with all metals but the very finest alloy steels, while in immunity from flaws and uncertainty in regard to physical properties, woods are even superior to metals, especially when well seasoned. Unseasoned woods beside being heavy are often less than half as strong as the same timber thoroughly dry.

Chemically and microscopically, wood is a multicellular structure of cellulose with a pronounced longitudinal grain, affording its greatest strength in a longitudinal direction, though some woods are enough tied together with transverse fibers to afford great resistance to splitting. This resistance is usually from one-tenth to one-twentieth of the tensile strength in a longitudinal direction.

Woods are commonly divided loosely into two classes—hardwoods and softwoods—though there is not really any distinct demarcation between the classes, there being a variety of qualities so great as to shade by imperceptible gradations from the softest to the hardest.

HARDWOODS

For a given bulk the best hardwoods are much stronger than most softwoods, besides generally possessing qualities of tenacity and flexibility that contrast favorably with the brittleness of some of the very strongest softwoods, but for a given strength within a given weight rather than within

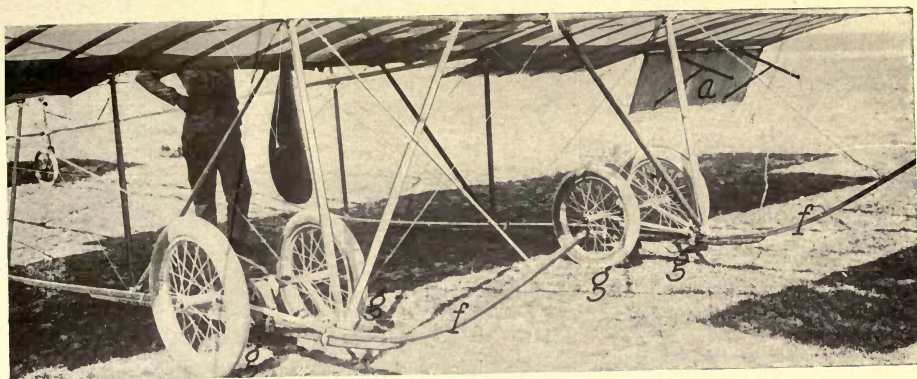

FIGURE 174.—Alighting Gear of Farman Machine. Note the runners *f f* and the wheels *g g*.

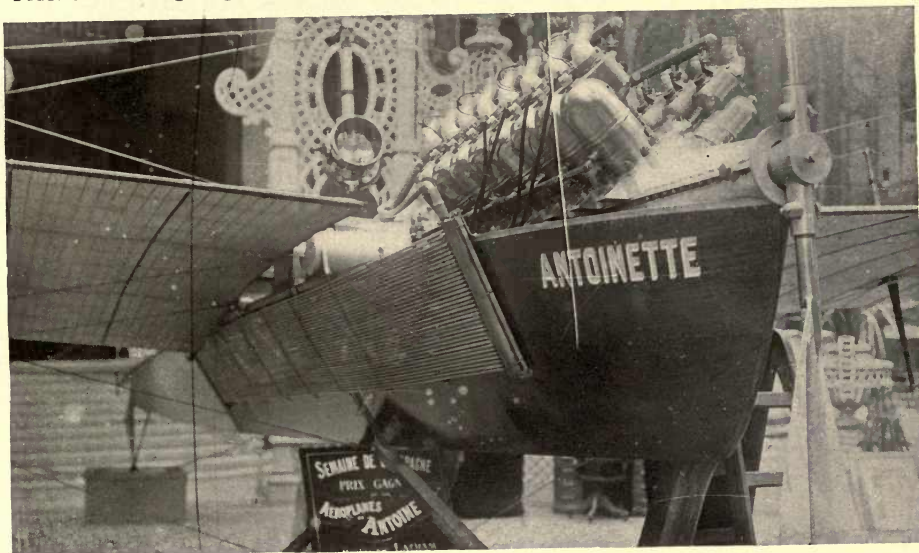

FIGURE 175.—Boat-like Body of Antoinette Monoplane. This machine, which is equipped with a hundred horsepower motor, will run on the land, in the water, and in the air.

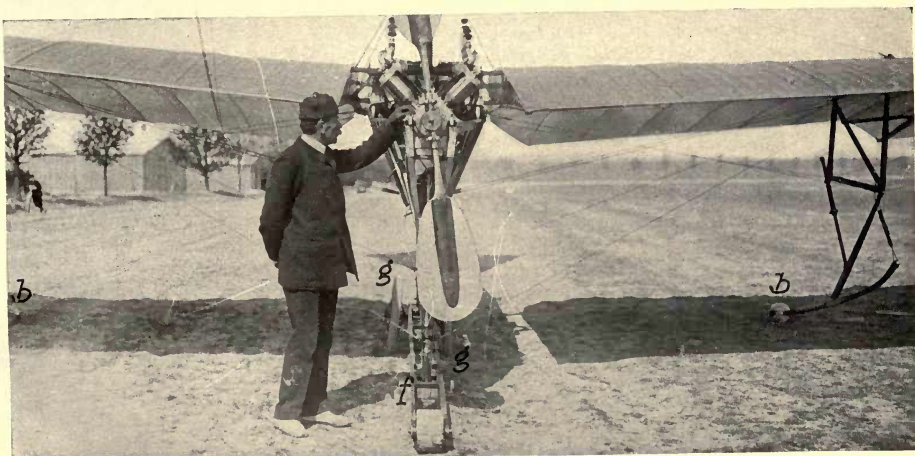

FIGURE 176.—Alighting Gear of Antoinette Monoplane. Most of the weight is carried on the two center wheels *g g*, with the spring-mounted spherical wooden rollers at *b b* to balance the machine. The runner *f* is an additional safeguard against shock in landing.

a given size, a few of the softwoods are superior to the strongest hardwoods.

Applewood is in its best qualities a remarkably fine timber, especially for service in which great resistance to splitting is required. For this reason it is much sought by makers of handles, chisel and other handles made of applewood being almost impossible to split even under the hardest hammering with a mallet. The difficulty of securing large clean pieces undoubtedly prevents more extensive use of this wood. For flying-machine propellers it would appear to possess particular merits.

Ash is proved second only to hickory in its usefulness for carriage shafts, ladders, handles, etc., but though it strongly resists utter breakage it lacks stiffness and therefore is best when pliability is a requisite. The foregoing applies especially to white ash—particularly to second-growth timber. Black ash splits easily and is even more flexible, but is very tough. It is much used for barrel hoops, while as a material for bows every archer knows it has few superiors. It is also applied to a considerable extent in the manufacture of oars and paddles.

Bamboo, botanically the largest of all grasses, grows up to a foot in diameter and 120 feet high in some of its 200 or more varieties, which are particularly plentiful in southern Asia and South America, and its marvelously light, elastic, and hard hollow stems are used the world over for everything from fishing poles to primitive but serviceable bridges. Split bamboo, in which the greater strength of the silicious surface of the canes is most favorably

placed to resist stresses, is a favored construction for fishing poles, and should readily find applica-

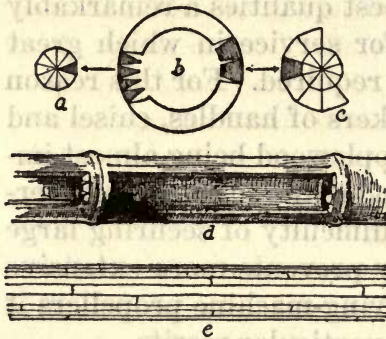

FIGURE 177.—Built-Up Bamboo Spar. At *a* and *c* are shown cross-sections of the spar *e*, glued up from pieces cut as shown at *b* and *d*.

tion to flying machines once the demand is created (see Figures 177 and 180).

In rather remarkable contradistinction to other woods, bamboo is a material that becomes less valuable as it is well seasoned, natural bamboo poles as large as two inches

in diameter or over almost invariably cracking and splitting longitudinally as they become well dried out with age.

Birch, either red or black, is among the most resistant of woods to splitting and is very fine grained and strong. In its different varieties birch is used for everything from articles requiring fine carving to ox yokes, saddle trees, etc. The bark of the common birch, used by the Indians for making canoes, baskets, etc., is a very light and strong material that might conceivably find some application in flying-machine construction.

Boxwood is even more resistant in small corners and edges than maple, for which reason it is much used for wood carving. Its great weight is a serious objection from aeronautical standpoints.

Elm has a rather interwoven grain and does not split easily, but though very strong it easily works

out of shape under stress if not well braced. It has particular merits for wing bars and other parts of a structure to which it may be required to tack fabric, because tacks do not split it readily. Elm is one of the lightest of the hardwoods, being of about the same weight as Honduras mahogany, but in its strength and density it really comes into an intermediate position between the hardwoods proper and the softwoods.

Hemlock is a fairly strong and exceptionally light wood, the ratio between its weight and strength being such as to rate it materially higher as a structural material than other woods popularly regarded as much stronger.

Hickory, especially second growth timber rapidly produced in the form of new shoots from the stumps of felled trees, is one of the strongest and toughest of all woods. This is strictly true only of the so-called "shellbark" and "white" hickories. Water hickory is rather soft and comparatively light, while the wood of the pecan (a variety of hickory) is hard and brittle, but nearly all of the other varieties afford the highest grades of material known to the woodworker. The common uses for which hickory is preferred over all other woods alone speak volumes for its quality—axe and pick handles, spokes for vehicle wheels, vehicle shafts, oars, etc., being among the more familiar applications. In flying-machine construction it is particularly suitable for members in which it is desired to combine great strength without the bulk necessary in spruce and other soft

wood members of similar resistance. For propellers it is probably unequalled. Hickory particularly resists splitting and transverse fracture, breaking when it does break gradually, with a tearing, fibrous, splintered parting. It decays readily, for which reason structures of hickory must be well protected from the weather by suitable finishes.

Holly is a hardwood of fairly light weight and superior qualities, and is particularly resistant to splitting, but the difficulty of securing it in suitable sizes and qualities restricts its use.

Mahogany, of the common quality from Honduras, is perhaps the lightest of all the true hardwoods; and in thin veneers, with crossed grain, has great strength, though ordinarily it is regarded as more remarkable for the quality of finish it will take than it is for purely structural merits. Spanish mahogany, though somewhat stronger, is considerably heavier.

Maple, though not the strongest of hardwoods, is lighter than most, does not split easily, and is superior to most other timbers in its ability to retain fine edges and corners under exposure to conditions that tend to cause chipping and marring.

Oak, though widely recognized as one of the strongest of woods, is too heavy to measure up well from flying-machine standpoints.

Walnut, though rather brittle, is very strong and light, and the best French or Circassian walnuts are very successfully used in the manufacture

of wooden propellers, though they seem unsuited to less-specialized uses.

SOFTWOODS

The distinguishing quality of the softwoods is their great bulk for a given weight, allowing the highest strength to be secured not per unit of bulk but per unit of weight.

Pines, of a great range of varieties and qualities, are among the strongest of all timbers, though the different kinds vary widely in their properties. The best clear white and red pines, free from pitch, are second only to spruce in their lightness and strength. Both of these are extensively used by boat-builders, besides for innumerable purposes of less critical requirements.

Poplar—the term by which several varieties of whitewood and basswood are commonly known—though these are not true poplars at all—is very tough and durable, and is lighter than almost any other wood possessing strength qualities meriting consideration. Its weight is often as low as twenty pounds to the cubic foot—only five pounds heavier than cork—and it rarely rises as high as thirty, even in specimens selected for close grain and density.

Spruce, which is really a fir, and thus closely related to the pines, is a wood that has first claim on the aeronautical engineer's attention. This is most particularly true of the silver fir, and the Norway and California spruces, all of which are unequalled for the spars of vessels, while the sec-

and is widely employed by musical-instrument makers for sounding boards. Selected, clear, and straight-grained spruce, or "deal" as it is termed in Europe, rarely weighs over thirty pounds to the cubic foot, and is tremendously strong for its weight. Spruce is very strong and stiff, does not easily warp, and will bend as much as elm without breaking, but being more elastic tends more strongly to spring back. It splits very easily, for



FIGURE 178.—Sections of Wooden Spars. The ends sought in these different constructions are light weight, great strength, and a minimum resistance to passage through the air.

which reason ends should be well wrapped with wire or cord, or run into sockets, while holes for nails, screws, and bolts should be bored full to avoid any wedging effect.

Willow, the "osier" of Europe, is the constituent of common wicker ware and furniture. Its strength in proportion to weight is very great because of its extreme lightness. It is much used for balloon baskets (see Page 105) and would appear to have a field before it in way of seats and housings for passengers in aerial vehicles (see Figure 248).

VENEERS AND BENDINGS

Veneered, bent, and built-up wooden structures are usually the strongest, because of the many opportunities they present of eliminating

flaws, of crossing grains to prevent splitting, and of building hollow members to combine the maxi-

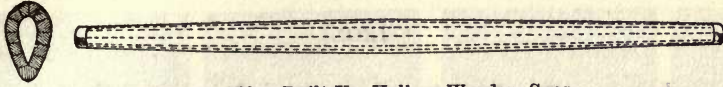

FIGURE 179.—Built-Up Hollow Wooden Spar.

mum of strength with the minimum of weight. Examples of built-up wooden structures appear in

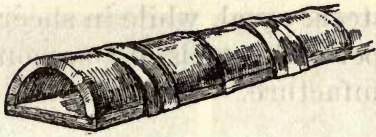

FIGURE 180.—Built-up Bamboo, Hickory, and Rawhide Wing Bar.

Figures 177, 178, 179, and 180. The hollow-box wing bars of the large Langley machine (see Page 137), possibly were the most

elaborate wooden structures ever designed, as they were certainly among the lightest and strongest.

METALS

Though weight for weight very few of the metals are stronger than the best woods, and these few are less superior than is commonly supposed, within a given volume of structure no materials approach the metals. Particularly in their tensile strengths do the metals excel the woods, for which reason they are much used in the form of wire.

For stays, strengthening wrappings, and control operation, wire is probably unrivalled. Another important use for metal is in sheet form, which also is cheap and inexpensive to handle, whether used for adding strength to joints and angles, or for more elaborate purposes. Simple

castings, too, of the lighter aluminum and other alloys, can be made to serve many useful purposes.

IRON

Iron as a structural material is one that has suffered from comparison of its impure qualities with ordinary steels, but really pure iron is a metal of many merits, chief among which is a resistance to shock loads that few steels equal, while in sheer strength it is at least superior to steels of common qualities or careless manufacture.

STEEL

Ordinary steel is a compound of carbon and iron, with the carbon ranging from 10 to 200 ten thousandths, $\frac{1}{10000}$ being known in the steel trade as one "point." Thus, "30-point" carbon steel is steel containing $\frac{30}{10000}$ of carbon. Steel is distinguished from all other materials by its tremendous strength. In its strongest forms, however, it is hard and brittle, for which reason annealed varieties of moderate strength are most used in structures in which breakage can become very serious. Different steels weigh from 480 to 490 pounds to the cubic foot—from 3.5 to 3.7 cubic inches to the pound. The strongest form of carbon steel is fine wire, such as piano wire and the wire used in bicycle spokes. The latter are commonly to be had with ultimate tensile strengths as high as 300,000 pounds to the square inch, with an "elastic limit"—permissible load without perma-

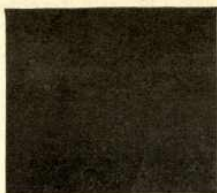

A.—Rubber-Faced Silk Used on "Golden Flyer."

B.—Balloon and Aeroplane Material.



C.—Rubber-Faced Silk Used on "Silver Dart."

D.—Treated and Untreated Balloon Silk.

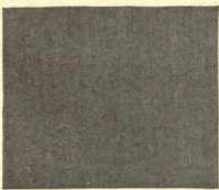
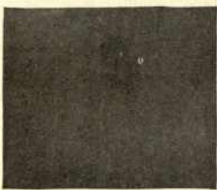

E.—Continental Rubber-Faced Percalé No. 109.

F.—Continental Rubber Faced Percalé No. 111.

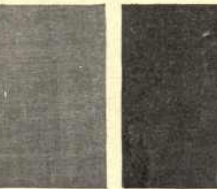

G.—"Tanalite."

H.—Continental Unvulcanized Joining Material.



I.—Rubber-Faced Linen Fabric.

J.—Continental.

K.—Continental.



L.—Balloon or Aeroplane Fabric.

M.—Balloon or Aeroplane Fabric.

FIGURE 184.—Texture of Modern Aeroplane Fabrics—Reproduced Actual Size. Of the above, A weighs only 3 ounces to the square yard; C weighs only 2 ounces to the square yard; D is a balloon silk, much used for tents, weighing from 3 to 4 ounces a square yard; E and F are rubber-faced percales weighing about 3½ ounces to the square yard; G is a light tent material of some suitability for aeroplanes; H is for covering seams; I, J and K are light linen fabrics, and I and M are suitable for either aeroplanes or light balloons. The strengths range from 45 pounds to the inch of width in C, to 100 pounds in the case of I, J and K.



ment deformation—nearly as high as the ultimate strength.

Alloy Steels are a rather modern development in steel manufacture, being produced by the addition to the carbon and iron of small quantities of certain less common metals—notably nickel, chromium, vanadium, uranium, and tungsten. By the use of these it is found that the different qualities of ultimate strength, elastic limit, and resistance to shock are vastly enhanced, provided that in addition to the proper admixture of the proper ingredients the metal is subjected to proper heat treatment in its manufacture.

In the best grades of chrome-nickel steel elastic limits of 110,000 and 120,000 pounds to the square inch are not uncommon in unannealed qualities of metal, so far from brittle that with sufficient force they can be bent 180 degrees without fracture, while the same steels hardened often test fully twice as high.

It is one of the interesting problems of modern metallurgy and engineering to discover just what may be the greatest strengths possible to secure with combinations of different metals—in which combinations it is to be noted that there appears to be little likelihood of any advantageous elimination of iron and carbon.

It has been stated on good authority that Krupps, of Germany, has produced test bars of a secret tungsten-containing steel with which tensile strengths of over 600,000 pounds to the square inch have been achieved. No such steel is at present

on the market in commercial shapes, nor are the torsional and other qualities of these extraordinary fibrous and tough steels supposed to be very high.

It is a difficulty in the utilization of all steels that much of their strength depends upon their proper heat treatment.

CAST IRON

Cast iron is iron admixed with an excess of carbon over the amount permissible in steels. Aside from the facility of working it by casting in molds, cast iron possesses certain qualities that render it peculiarly suitable for gasoline-engine cylinders. These qualities are its resistance to high temperature, its immunity from corrosion, and its capacity to take and retain a much smoother finish than it is found possible to secure in steel or other metals used for the same purpose.

ALUMINUM ALLOYS

Though practically worthless in its pure form for such purposes, some of the alloys of aluminum with other metals stand second only to the best steels among the metals, and are even superior to these in their ease of manufacture without impairment of their more valuable characteristics.

Aerial Metal is an alloy of aluminum and lithium, is remarkably strong, and in some qualities is only one and one-half times as heavy as water.

Aluman is an alloy of 88% aluminum with 10% zinc and 2% copper. It is one of the strongest of the aluminum alloys and is readily forged and milled, but its weight is an objection to it.

Argentalium is a recently patented alloy of aluminum and silver, originated in Germany. Little data concerning its qualities are as yet available, though in the preferred proportions its specific gravity is known to be about 2.9.

Chromaluminum is another German alloy of patented formula, containing aluminum with chromium and other ingredients. It weighs the same as argentalium and is stronger than any other known aluminum alloy, with the possible exception of the very highest qualities of magnalium.

Magnalium is an alloy of aluminum and magnesium, the proportion of the latter varying from 2% to 10%. Its weight is less than that of pure aluminum, and in its strongest qualities—those containing the most magnesium—it has been extensively applied in aeronautical engineering. It resists corrosion about as well as aluminum, and is readily cast, forged, machined, rolled, and drawn, with little difficulty in realizing its excellent qualities in the final manufactured shapes.

Nickel-Aluminum is rather heavier and not as strong as magnalium.

Partinium, or Victoria-Aluminum, is a more or less secret aluminum alloy much used in Europe for automobile crankcases and gearboxes. It contains very small proportions of copper and zinc, casts well, and is very light.

Wolframium is an alloy of aluminum with tungsten, with traces of copper and zinc. It is the subject of a German patent and is extensively

used in the Zeppelin dirigibles (see Page 87). Wolframium is readily worked into almost any desired form, and is fully as strong as the more practical qualities of magnalium, but it weighs more than the generality of aluminum alloys.

BRASSES AND BRONZES

Copper with zinc, tin, aluminum, phosphorus, etc., constitutes the various qualities of brasses and bronzes, which, while strong and easily worked, tend to be rather too heavy for most aeronautical purposes.

Aluminum Bronze, of 90% copper with 10% aluminum, is very tough and elastic, almost incorrodible, and little affected by changes of temperature. It casts and machines well with proper methods, but is very heavy.

Phosphor Bronze is exceptionally strong in

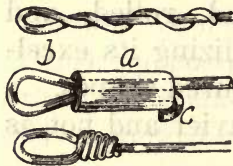

the form of wire and small fittings, such as turnbuckles and the like.

METAL PARTS

FIGURE 181. — Methods of Fastening Wire Ends. If the loop is made like the upper view, it will either come loose or draw into the shape that is shown in the lower view, which therefore is a proper form to use at the beginning. Another common method is to use the flattened piece of steel tubing shown at *a* in the middle view, the wire being simply bent as at *b* and *c*, which will hold it securely.

Of the metal parts most used in modern aerial vehicles, those of greatest importance and interest are the various qualities of wire, strut sockets, turnbuckles, and wire tighteners. Several approved methods of fastening wire ends are illustrated in Figure

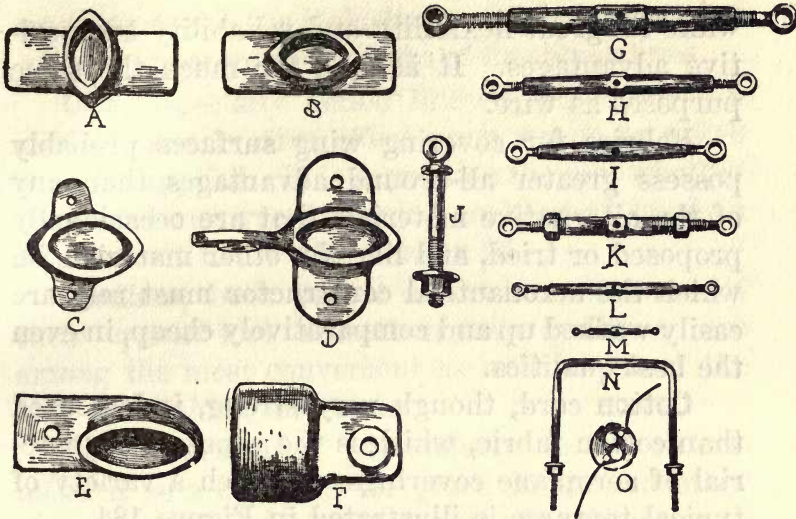

FIGURE 182.—Strut Sockets and Turnbuckles. A, B, and C are cast aluminum sockets for the attachment of struts to the sides of cross members. D is such a socket with the addition of a lug for the attachment of a hinged member. E is for the attachment of a lug to the end of a cross member. F is a strut tip, for hinging to a socket of the type D. G, H, I, L, and M are turnbuckles, with oppositely-threaded ends, for tightening wire stays. These are operated by a pin thrust through the center holes, and are locked by running a wire through this and the wire eyes in the ends. K is a similar turnbuckle, but is kept from loosening by the locknuts at its ends. J is a bolt, eye-ended for the attachment of a wire stay. N is a clip for clamping wooden bars together, and O is a wire tightener, similar to that in Figure 183, the application of which does not involve cutting the wire.

181, while in Figure 182 are shown groups of strut sockets and turnbuckles, and in Figure 183 a wire tightener that avoids cutting the wire.

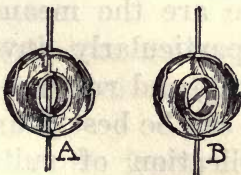

FIGURE 183.—Wire Tightener.

CORDAGE AND TEXTILES

Cordage is of great utility from many standpoints, and though much weaker than wire for a given size, with some materials it compares most favorably with the metals on the basis of a given weight,

while its great flexibility and reliability are positive advantages. It is used for much the same purposes as wire.

Fabrics for covering wing surfaces probably possess greater all-around advantages than any of the alternative materials that are occasionally proposed or tried, and like the other materials on which the aeronautical constructor must rely are easily worked up and comparatively cheap, in even the best qualities.

Cotton cord, though very strong, is less used than cotton fabric, which is the commonest material of aeroplane coverings, of which a variety of typical textures is illustrated in Figure 184.

Linen fabrics have been discussed on Page 94.

Silk fabrics also have been considered hereinbefore (see Page 93).

PAINTS AND VARNISHES

Next in importance to the production of a strong and efficient structure are the means of maintaining it so. These particularly involve avoidance of warping, loosening, and rusting, due to the action of moisture, and can be best guarded against by the proper application of suitable finishes.

Aluminum Paint is used over all wooden surfaces of the Wright machines for a double purpose. One is the protection of the wood and the other is the exposure of the least checking or

cracking, which the inelasticity of this finish makes at once apparent in the form of fine black lines.

Oils, especially boiled linseed oil, exercise a marked preservative effect upon woods to which they are applied. It is a question though, whether the sometimes recommended soaking of wood in oil does not materially weaken it.

Shellacs, both yellow and white, because of their quick and smooth-drying qualities, are among the most convenient as well as one of the best of finishing materials.

Spar Varnish is particularly to be recommended as a covering for glued joints and other elements upon which the action of moisture is to be feared.

Miscellaneous finishes, other than the foregoing, exist in great variety. Most worthy of present consideration are the various enamels, japans, and lacquers used to protect metal surfaces from rust and corrosion.

MISCELLANEOUS

Of other materials interesting to the student of practical aeronautics there is a considerable number.

Catgut, from the intestines of small animals, resembles rawhide in its quality of stretching when wet and shrinking as it dries, making it excellent for tightly-wrapped bindings of spar ends. It is much used in musical instruments and for stringing snowshoes, tennis racquets, etc.

China Grass, used for chair seats, is five-sixths as strong as silk, section for section, and is little if any heavier.

Hair, especially human hair, is little inferior to silk in strength and lightness.

Rawhide is much used for covering and binding together the parts of wooden saddle trees, being applied wet and allowed to shrink on. Thus used it would appear to have value in aerial-vehicle elements, as is suggested in Figure 180.

Silk Cord is, almost without exception even among the metals, one of the strongest structural materials known, as is evident from the tabular comparisons at the end of this chapter.

Silkworm Gut, the so-called "catgut" of fish-line leaders, is very close to silk in strength.

ASSEMBLING MATERIALS AND METHODS

A serious obstacle in the way of making wood or other structures of great strength is that of devising joints of strength equal to that of the unbroken material, the best joints tending to fall much short of the strength that it is easy to secure in unbroken members.

Nails for fastening together wooden parts are, though a common method, a most inadequate one for anything so delicate and exacting as a flying-machine structure.

Glues and Cements afford much stronger constructions, especially when used in combination with wrappings of wire, cord, leather, or rawhide, while reinforcement by metal plates and enlarged

ends to the members is found of great advantage in wood structures.

Screws, judiciously used to prevent the slipping apart of different elements rather than as the sole means of securing them together, are not positively objectionable, though it is desirable to avoid them.

Bolts, of small diameter and high-quality steel, and with large washers under heads and nuts, are successfully utilized in many modern aeroplanes, through wood and metal members proportioned to receive the bolt holes without weakening.

Clips, of the type illustrated at N, Figure 182, are excellent for clamping two or more wooden bars together.

Rivets, while not the best, constitute an easily-applied and fairly effective means of joining light metal parts together.

Electric Welding is an almost perfect though not always readily applicable method of joining parts of similar or dissimilar metals with minimum impairment of strength.

Autogenous Welding, by the use of the intense but readily-localized heat of the oxy-acetylene flame, is an excellent modern method that in expert hands is easily applied to a great variety of assembling operations.

Brazing, which is practically a means of soldering iron and steel with a solder of very soft brass, or "spelter", was first developed into a really reliable and effective process in the evolution of the bicycle industry. Brazed joints appear well and

hold well, but the prolonged heating they involve weakens all but the softest annealed steels.

Soldering, properly done, is a dependable means of securing light parts together, or of reinforcing parts primarily held by other means, as in the case of twisted wire ends (see Figure 181), which may be soldered to afford added security.

TABULAR COMPARISON OF MATERIALS

WOODS

NAME	Pounds to Cubic Foot	Tensile Strength (in pounds)	Length of Material Sustained*	Compressive Strength (in pounds)	Column of Material Sustained*
Alder.....	6,000 — 7,000
Applewood.....
Ash.....	43	11,000 —	36,800	4,600 — 8,000	26,760
Bamboo.....	20
Beech.....	43	8,000 — 12,000	33,660	8,000 — 9,000	25,245
Birch.....	35	7,000 — 10,000	41,000	5,000 — 10,000	41,000
Boxwood.....	64	10,000 — 15,000	33,750	8,000 — 10,000	22,500
California Spruce.....	12,000 — 14,000
Cedar.....	35	4,000 — 9,500	38,950	4,000 — 6,500	26,400
Cherry.....	5,000 — 6,500
Chestnut.....	7,000 — 12,000	4,000 — 4,800
Elm.....	36	8,000 — 13,000	53,000	8,000 — 10,000	40,750
Fir (New England Spruce).....	5,000 — 10,000
Fir (Norway Spruce).....	32	5,000 — 12,500	56,250
Hemlock.....	23
Hickory.....	43	10,000 — 14,000	46,880	8,000 — 9,800	32,800
Holly.....	10,000 — 15,000
Lancewood.....	45	8,000 — 15,000	48,000
Larch.....	6,000 — 10,000	3,000 — 5,500
Lignum Vitae.....	10,000 — 12,000	8,000 — 9,600
Locust.....	10,000 — 15,000	7,500 — 9,500
Mahogany (Honduras).....	35	5,000 — 8,000	32,800
Mahogany (Spanish).....	45	8,000 — 15,000	48,000	7,000 — 8,000	25,600
Maple.....	40	8,000 — 10,000	36,000	5,000 — 6,000	21,600
Oak (English).....	9,000 — 12,000	6,500 — 10,000
Oak (Live).....	67	10,000 —	21,500	8,000 — 10,000	21,500
Oak (White).....	43	10,000 —	33,500	5,500 — 8,000	26,800
Oregon Pine.....	9,000 — 14,000
Pear.....	7,000 — 10,000	7,500 —
Pine (Pitch).....	8,000 — 10,000
Pine (Red).....	5,000 — 8,000	6,000 — 7,500
Pine (White).....	29	3,000 — 7,500	37,240	3,000 — 6,000	29,800
Pine (Yellow).....	34	5,000 — 12,000	50,820	6,500 — 10,000	42,350
Plum.....	7,000 — 10,000
Poplar.....	7,000 —	5,000 — 8,000
Spruce.....	31	5,000 — 10,000	46,450	4,500 — 6,000	27,870
Sycamore.....	39
Teak.....	10,000 — 15,000	6,000 — 10,000
Walnut (Black).....	8,000 —	5,600 — 7,000
Walnut (Hickory).....	42
Walnut (White).....	7,500 — 9,000
Willow.....	37	10,000 —	28,800	3,000 — 6,000	16,280
Yew.....	50

* See opposite page.

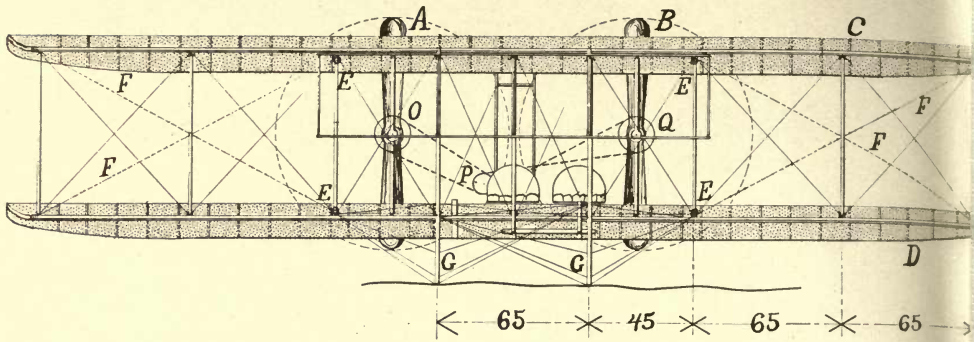

FIGURE 185.—Scale Drawings of Wright Biplane. This biplane particularly differs from others in its use of a runner alighting gear *G G*, starting being effected by auxiliary devices, involving a small truck on which the machine is mounted, a wooden rail on which this truck runs, and derrick and weight arrangement for imparting the initial impulse. The advantages of this system are several. Other things being equal, the machine is lighter than those in which wheeled starting gears are provided, free flight is attained with a much shorter run, and the runners are decidedly superior to wheels for alighting on rough ground, over which they slide with a minimum risk of breakage. The main planes *C D* are double surfaced, with double ribs and enclosed wing bars, and are narrowed at their ends. All of the front rectangles are rigidly trussed by diagonal wires, and also are the center rectangles at the rear, but the four outer rear rectangles are kept in shape only by the movable guys *F F F F*, which pass over the pulleys *E E E E*. The consequence is that endwise movement of the lower of these wires, effected by the sidewise movement of a lever, oppositely warps the wing tips in such a manner as to control lateral balance and steering. The double vertical rudder *J*, carried on the spars *K K*, is worked by a forward and backward movement of the same lever that when laterally moved controls the wing warping, so that angular movements of the lever exert a compound controlling effect. The front elevator *H* is normally flat in the latest Wright machines but when moved by the operating bar *I* from the lever *N* it does not merely pivot; it springs into curved form, with the concavity upwards or downwards, as the case may be, so that a surface of maximum effectiveness is presented to the air. This construction, which is the subject of a patent, is shown more in detail in Figure 84. Propulsion is by twin propellers *A B*, 8½ feet diameter, oppositely rotated by the ingenious double-chain driving system originated by the Wrights in which one chain—that to the sprocket *Q*—is crossed, while the other—to *O*—is used in the normal manner. The engine, with shaft *P*, is a 25-horsepower, four-cylinder, water-cooled design, weighing about 180 pounds. A radiator composed of vertically-placed flat copper tubes extending the whole distance between the main surfaces takes care of the cooling. Two or three passengers can be carried, seated near the center of the lower surface—just enough to one side to balance the weight of the motor—with their feet braced against the bar *M*. For convenience in storing and shipping the outer ends of the main surfaces dismount at *R R*, while the runners disconnect under the forward edges of the surfaces. The runners in the latest Wright machines are made considerably higher than formerly. The weights of the different Wright machines have ranged from 800 pounds to 2,000 pounds, varying with the design and the weight of fuel and passengers carried. All dimensions are given in inches, and it is to be noted that the sectional dimensions of the principal wooden members are included. For further details of the Wright construction, reference should be had to Figures 75, 110, 139, 161, 163, 165, 166, 186, 187, 188, 189, 190, 191, 192, 193, 194, 195, and 196.

METALS

NAME.	Pounds to Cubic Foot	Tensile Strength (in pounds)	Length of Material Sustained	Compressive Strength (in pounds)	Column of Material Sustained*
Aerial Metal.....	98	60,000-70,000	106,105
Aluman.....	184	42,660.....	33,380
Aluminum.....	168	38,393.....	32,910
Aluminum Bronze.....	481	92,430.....	27,460
Chromaluminum.....	184	68,990.....	50,080
Brass.....	526	85,320-86,742	23,750
Cast Iron.....	444	20,000-35,000	11,350	75,000-150,000	48,640
Copper.....	56,880-58,302
Iron (Commercial).....	480	58,000.....	17,400	28,000.....	8,400
Iron (Pure Wrought).....	482	119,448.....	35,650
Magnalium.....	152	41,238-63,990	54,040
Nickel-Aluminum.....	184	56,880.....	44,560
Partinium.....	178	21,330.....	16,020
Steel (Cast).....	485	80,000.....	23,750
Steel (malleable castings).....	483	22,000.....	6,560
Steel (common piano wire).....	490	99,540-132,246	40,500
Steel (tinned piano wire).....	490	246,006-312,840	91,940

MISCELLANEOUS MATERIALS

Boat Paper.....	16,800.....
Braided Linen.....	39,520.....
Catgut.....	25,000-36,175
China Grass.....	22,752.....
Glue.....	500-750
Hemp.....	90	6,825-17,000	75,000.....
Horn.....	9,000.....
Human Hair.....	50,000-79,000
Ivory.....	16,000.....
Leather.....	3,000-5,000
Manila.....
Rawhide.....	12,000.....	15,000.....
Silk.....	101	35,000-62,028	88,436.....
Silkworm Gut.....	42,240-90,000
Whalebone.....	7,600.....

*This lucid method of making weight-for-weight instead of bulk-for-bulk comparisons of strength is borrowed from R. H. Thurston's "Materials of Aeronautic Engineering", a paper that was presented before the International Conference on Aerial Navigation, held at Chicago in 1893, and which contains much information and data hardly excelled in completeness and accuracy in any more up-to-date publication.

TRANSVERSE STRENGTH OF WOOD BARS†

MATERIAL	SIZE	WEIGHT	LOAD SUSTAINED
Elm.....	1/2 x 1/2 x 12 inches	5 1/2 ounces	900 pounds
Spruce.....	1/2 x 1/2 x 12 inches	4 1/2 ounces	900 pounds
Elm.....	1 1/8 x 1 1/8 x 12 inches	4 1/2 ounces	880 pounds
Spruce.....	1 1/8 x 1 1/8 x 12 inches	3 1/2 ounces	760 pounds
Elm.....	1 x 1 x 12 inches	4 ounces	450 pounds
Spruce.....	1 x 1 x 12 inches	3 1/2 ounces	600 pounds
† Elm.....	1 1/8 x 1 1/8 x 12 inches	3 1/2 ounces	390 pounds
† Spruce.....	1 1/8 x 1 1/8 x 12 inches	3 ounces	475 pounds
Elm.....	1 1/4 x 1 1/4 x 12 inches	2 1/2 ounces	275 pounds
Spruce.....	1 1/4 x 1 1/4 x 12 inches	2 1/2 ounces	280 pounds
† Elm.....	1 1/2 x 1 1/2 x 12 inches	2 1/2 ounces	175 pounds
† Spruce.....	1 1/2 x 1 1/2 x 12 inches	2 ounces	175 pounds

†These tests were all made with the bars supported at their extreme ends. ‡Supported edgewise.

CHAPTER TWELVE

TYPICAL AEROPLANES

The information and data contained in this chapter are intended to provide the practical worker with such particulars and details of successful modern aeroplanes as will enable him readily to reproduce and operate at least the simpler machines, several of which are exceedingly easy and inexpensive to build—a fact that is as absolutely true as it is generally unappreciated.

No attempt has been made, either in the text or in the scale drawings that pertain to this chapter, to supply slavishly accurate data concerning every trifling detail of the machines considered. On the contrary, there have been deliberately introduced a number of carefully-considered changes in wholly minor details, intended to reduce the labor and cost of construction in directions that otherwise might prove sources of difficulty to the amateur experimenter.

It seems proper here to emphasize the fact that neither the construction nor operation of the best modern aeroplanes call for the extraordinary knowledge and expertness they are popularly supposed to demand. On the contrary, rather than much knowledge the construction of an aeroplane

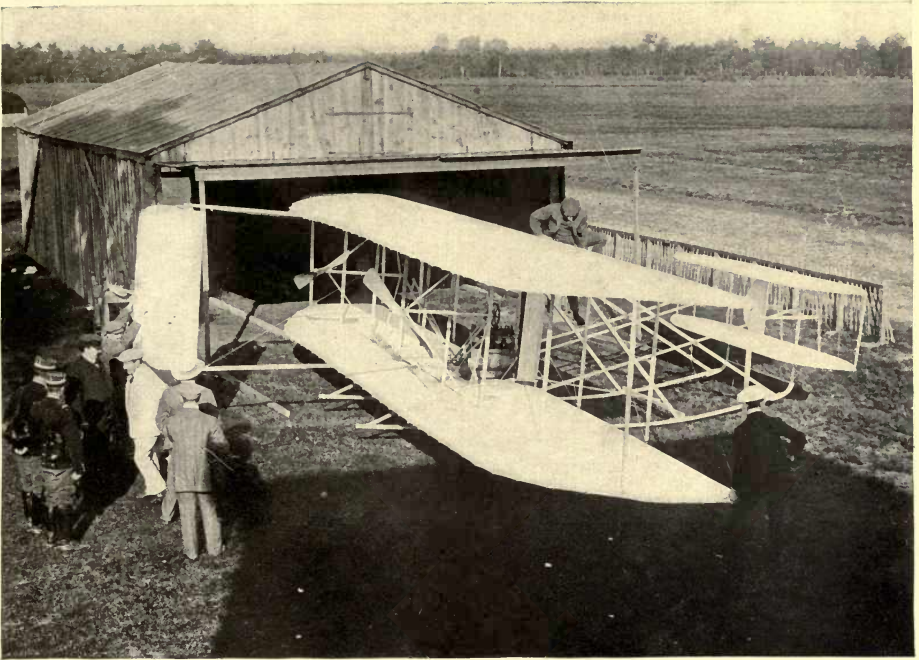

FIGURE 186.—Side View of Wright Machine.

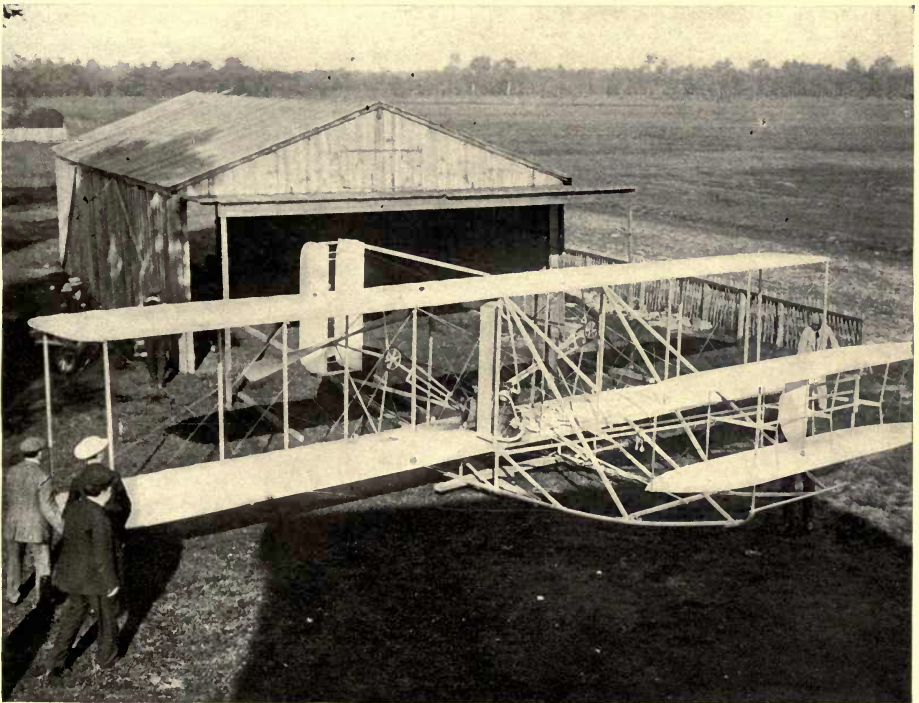

FIGURE 187.—Three-Quarters View of Wright Machine.

requires much care—the most painstaking attention to the perfection of every last detail. As for the matter of operation, with many of the most successful machines this is absolutely easier than learning to ride a bicycle in so far as mere manual skill is concerned, though the need of a cool head and reasonable daring is not to be escaped.

By far the most essential points in aeroplane building are provision of the correct wing curvatures and the proper proportioning, arrangement, and control of the different sustaining, stabilizing, and balancing surfaces—with due attention, of course, to structural strength and security. The latter, however, may be quite safely left to anyone possessed of reasonable mechanical ability to carry out largely in accordance with individual ideas and facilities, which with the exercise of reasonable judgment are as likely to prove practical and satisfactory in one case as in another.

The initial practise flights with a new or unfamiliar machine should never under any circumstances be undertaken in the slightest wind, or elsewhere than over an unobstructed and very uniform surface of great extent, permitting close-to-the-ground flight while avoiding the dangers of running into terrestrial obstacles.

It should be clearly understood, too, to the extent that the reader may undertake the building and operation of such constructions as may be protected by patents, that the law only permits this when such reproduction is done not merely for exclusively personal use (which many persons

imagine is allowed) but solely and only for the purpose of effecting improvement.

ANTOINETTE MONOPLANES

These highly successful machines, which in their latest forms have evolved to the construction illustrated in Figure 212, which shows the dimensions and outlines of the "Antoinette VII", with which Hubert Latham made his second attempt to cross the English Channel, are much too complicated for the amateur to build, as must be very evident from the details of the Antoinette wing structures shown in Figures 71, 72, and 101.

BLERIOT MONOPLANES

These remarkable machines are at present built in three principal models, of which the single passenger, the "Bleriot XI", is much the most interesting, it being simple and inexpensive to build, light in weight and very portable, and a wonderfully safe and speedy flier, as is sufficiently attested in the records it holds. In reproducing this machine, it will be sufficient to follow substantially the details given in Figure 197. The exact curvatures of the wing sections are not to be had in quite exact figures, but the curves shown in this scale drawing are close enough approximations to afford satisfactory operation when enlarged to the actual size. Most of the smaller parts of the monoplane—the clips for assembling the framing, the turnbuckles, the wheels and tires, the motors, and the aluminum-alloy frame braces and strut sockets

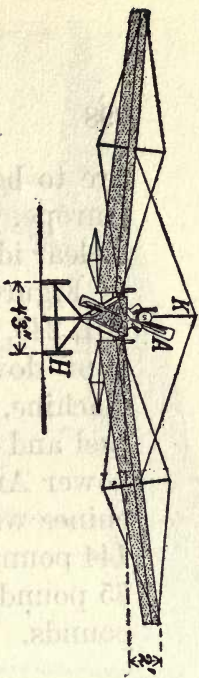
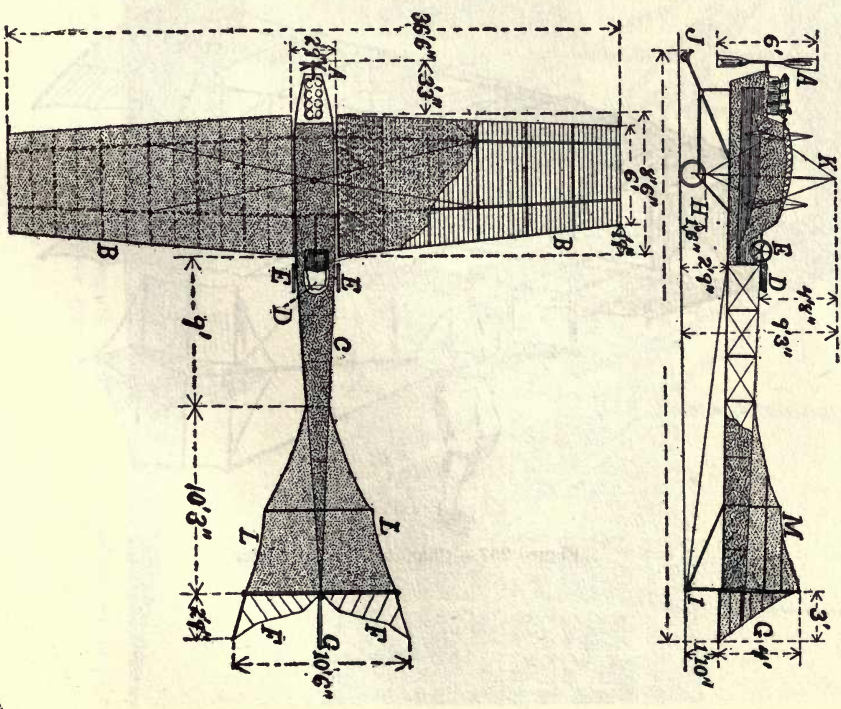

FIGURE 212.—Scale Drawing of Antoinette Monoplane. This machine consists primarily of the trussed wooden body *C*, mounted on the wheeled running gear *H*, and bearing at its forward end the main wings or sustaining surfaces *B B*. These wings are of the double-surfaced type, pronouncedly curved in cross section and very thick at their centers, being built up on a most elaborate system of internal trussing, chiefly constituted of a great number of light ribs and struts built over two main girder-like wing bars. The wings are mounted at a slight dihedral angle, the rise being about two feet in the length of 17½ feet, and are pivoted against the body *C* in such a manner that by rocking them differentially by means of the control wheels *E E* lateral balance is maintained as effectively as by the use of wing warping or ailerons. The wings are securely stayed to the mast *K* and to the lower portions of the body sides. At the rear end of the body there are provided the horizontal rudder surfaces *F F*, the vertical rudder *G*, the horizontal fins *L L*, the vertical fin *M*, and the support *I*. In addition to the wheels of the alighting gear *H* there is provided the strut *J* to prevent the machine from tipping over forward in alighting. The single propeller *A* is a paddle-like construction wholly of metal, built up by autogenous welding, and is revolved at about 1,200 revolutions a minute by the eight-cylinder V-shaped, 50-horsepower Antoinette motor placed immediately behind it, and on the crankshaft of which it is mounted. Unusually comfortable accommodation is provided for the operator in the cockpit at *D*. The wings are covered with light cotton fabric—a rubberized percale, which weighs only three ounces to the square yard, stands a pull of 45 pounds to the inch of width, and is perfectly waterproof.

The Antoinette construction has been frequently varied, different machines having been built with aileron control, different types of alighting gears, low and high power, etc., but all of them have proved capable fliers.



are to be purchased at very reasonable prices in Europe. In addition to following Figure 197, for a clear idea of minor parts a study should be made of Figures 1, 73, 112, 118, 157, 164, 171, 199, 200, 201, 245, 246, 247, and 249. The weight should be kept down to about 440 pounds for the bare machine, and must not exceed 700 pounds with fuel and passenger. The weight of the 22 horse-power Anzani motor with which one of these machines was flown across the English Channel was 144 pounds, that of the wheeled alighting gear was 65 pounds, and of the frame, or fuselage, about 60 pounds.

CHANUTE GLIDERS

These gliders, with which such remarkable work was done at Dune Park, Indiana, in

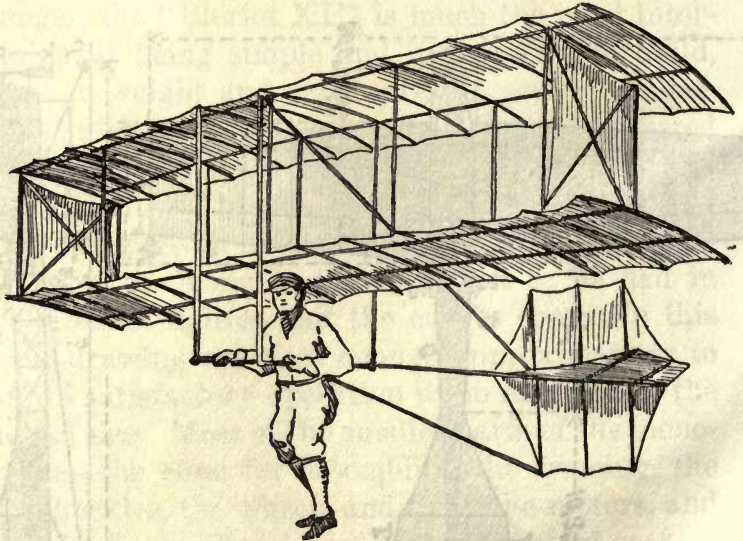

Figure 237.—Chanute Biplane Glider.

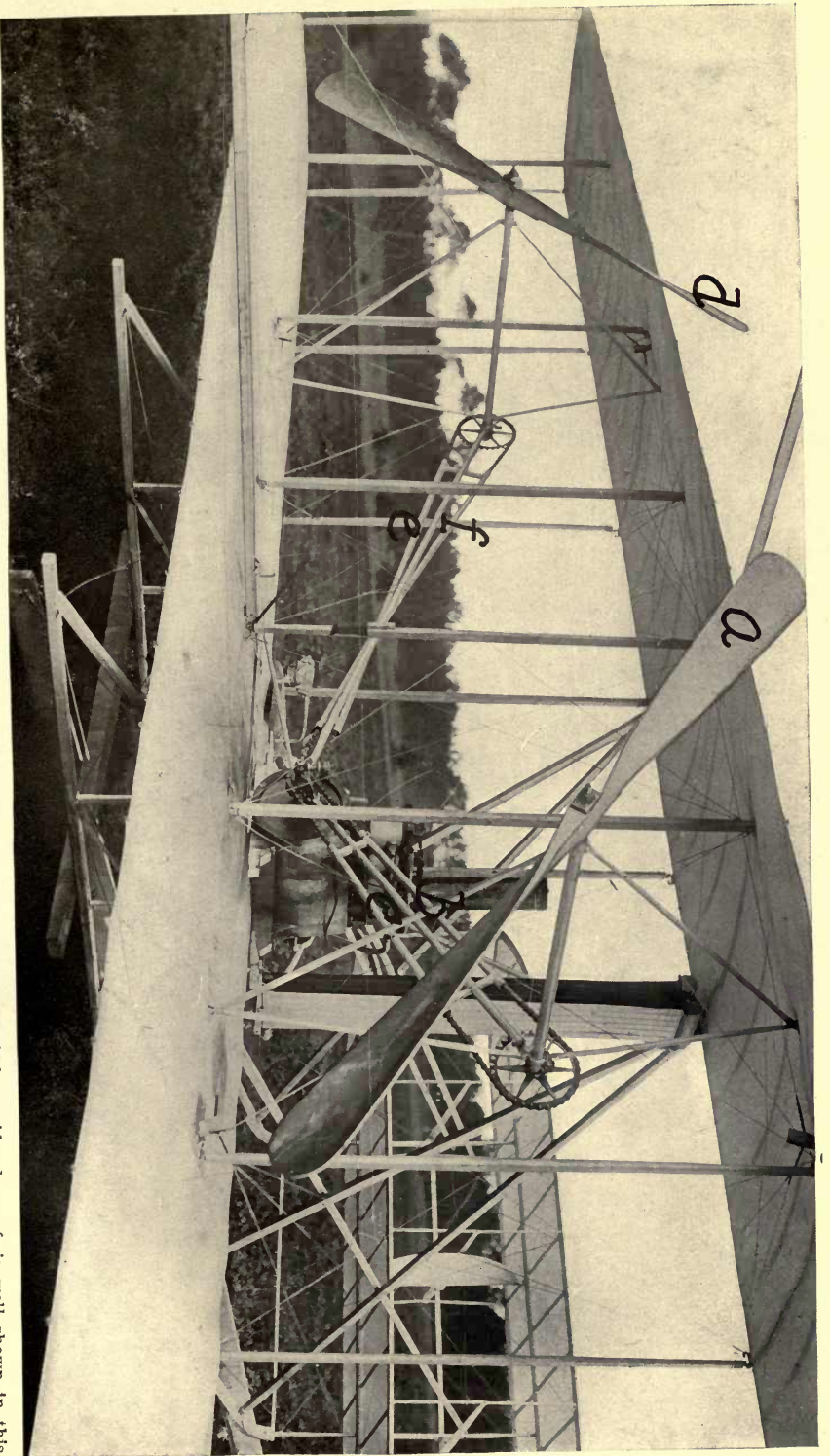

FIGURE 188.—Rear View of Wright Machine. The system of driving, by chains passed through the tubular guides *b* *c* *e* *f*, is well shown in this illustration. It is to be noted that the chains in the tubes *e* *f* are crossed, so that the propeller *d* revolves oppositely to *a*.

1895, were built in a considerable variety of forms, that from which the Wright biplane was developed being illustrated in Figure 237, while the essential details of an improved construction are shown in Figure 261. Though very cheap to build and quite safe and practical for very cautious experimenting, these early gliders fail to embody so many superior features used in present machines that it seems hardly advisable for the amateur of today to consider them otherwise than of purely historical interest.

CODY BIPLANE

This biplane, which weighs 2,000 pounds and is the largest that has ever flown, is patterned rather closely after the lines of the Wright machines, the chief differences being the greater size and the peculiar system of controlling lateral balance by manipulating the forward elevator elements as ailerons. Interesting and for the most part excellent features of design are the arching of both of the main surfaces, the flattening of the main sustaining surfaces towards their ends, and the extensive use of bamboo members, wrapped between joints to prevent splitting.

Various systems of arranging the main surfaces have been experimented with, by simply changing the lengths of the vertical spars and adjusting the trussing. The latest and most successful is that suggested by the dotted lines in the front view, Figure 202, in which it is seen that the 9-foot separation of the surfaces at their centers is decreased

to 8 feet at their ends, with the lower surface arched about 6 inches and the upper 18 inches.

Further details regarding the structural details of this machine will be found in Figure 202.

CURTISS BIPLANE

The main structure of this machine is a central body portion *EEK*, Figure 228 (also see Figure 229), mounted upon three 20x21½-inch pneumatic-tired wheels, and built of bamboo and Oregon spruce.

The main surfaces are slightly curved, as shown at *S*, and the chord measurement of the surfaces is 4½ feet, with a span of 29 feet. There are 24 light laminated spruce ribs in each main surface, and the fabric, rubber-faced silk, is wrapped around the front crossbars of the wing frames and kept taut at their rear edges by wire edgings drawn tight over each rib end. The silk is applied in laced-on panels—a 6-foot center section and four 5-foot sections to each surface, with 18-inch extensions at the ends of the wings.

The horizontal rudder *I*, with two surfaces, each 2x6 feet and spaced 2 feet apart by five struts along each edge, is placed 10 feet in front of the main surfaces, while a single horizontal surface of the same size is carried 10 feet to the rear to serve as a steadying tail. The vertical rudder is 2½x2½ feet. The triangular steadying surface *x*, at the center of this rudder, is no longer used.

Lateral balance is provided by the two ailerons *MM*, each 2x6 feet, located half-way between the

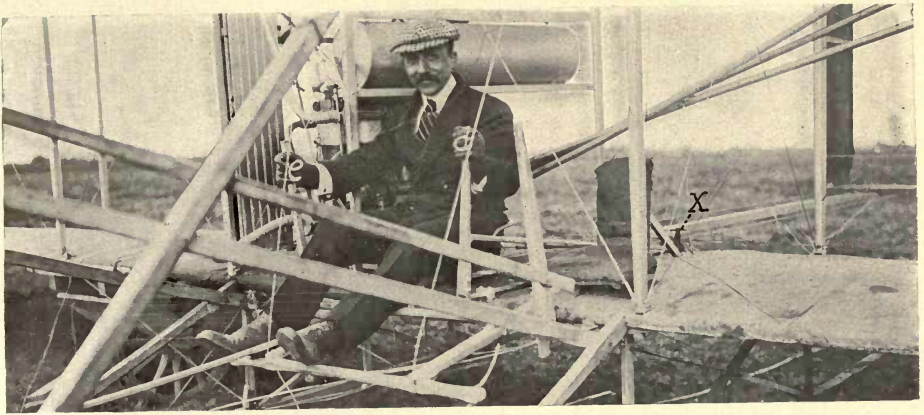

FIGURE 189.—Paul Tissandier Seated in Wright Biplane.

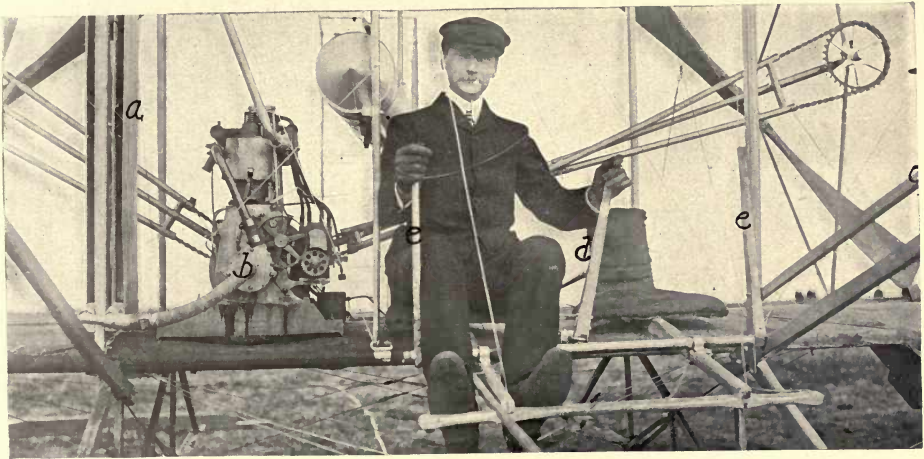

FIGURE 190.—Count de Lambert in Wright Biplane.

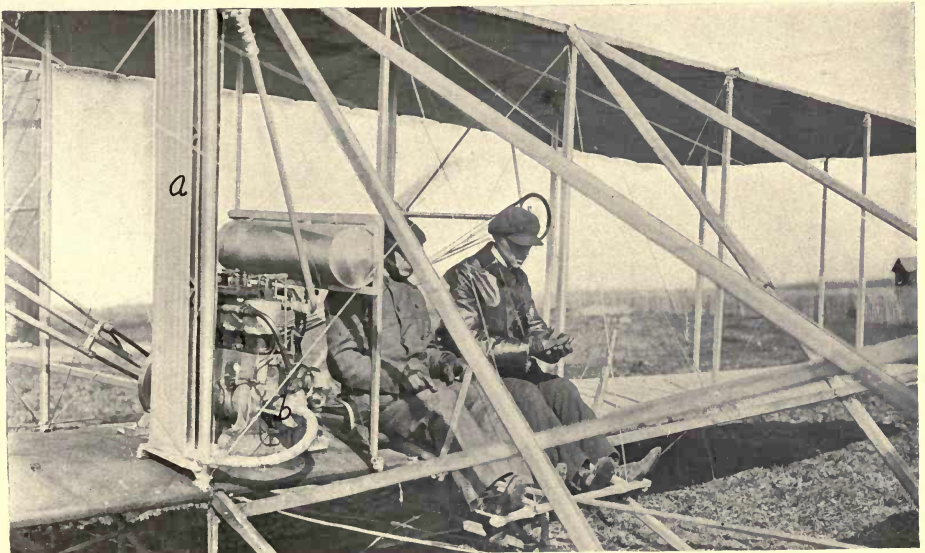

FIGURE 191.—Wilbur Wright Instructing a Pupil.

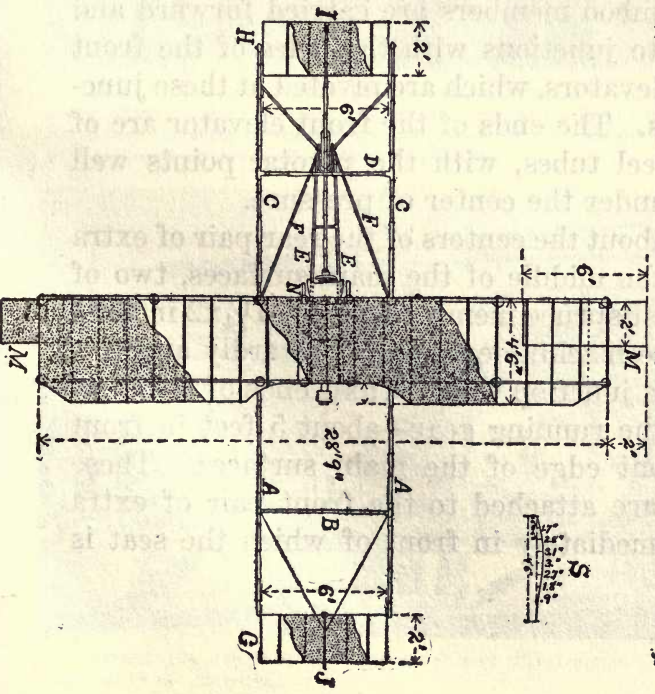
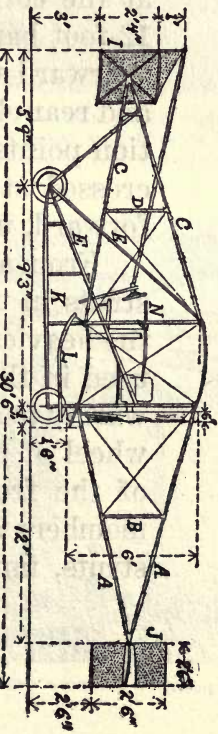
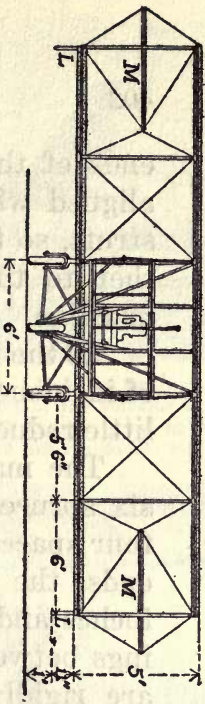

FIGURE 228. Scale Drawings of Curtiss Biplane. This biplane has two similar main surfaces, $4\frac{1}{2}$ feet \times $28\frac{3}{4}$ feet, spaced 5 feet apart. The curvature of the wing sections can be obtained by plotting from the diagram at *S* the height of camber from the chord being, at six-inch intervals from front to rear of the surface, 1.7 inches, 2.8 inches, 3.1 inches, 3 inches, 2.7 inches, 1.8 inches, and .9 inch, respectively. The wing bars, of which one is directly in the advancing edge and the other 1 foot from the rear edge, are both ribbed beneath the ribs which pass through pockets in the single-surfaces of a light rubberized silk material. This very unusual construction, which is met with in no other machine nor in any flying animal, cannot help but disturb the proper air flows beneath the wing surfaces, though it is evident that they do not do so to an extent sufficient to occasion serious difficulty. The stoutest elements in the framing are the spruce bars *E E*, on the upper and rearward ends of which the motor is mounted and at the forward ends of which is borne the small and very stout front wheel of the alighting gear. Lateral balancing is effected by the alleons *M M*, which are controlled by the shoulder forks *R N*, above the operator's seat, and against which he swings when the machine tilts, in such manner as to correct the equilibrium quite unobsciously. The double horizontal rudder, or front elevator *H*, is controlled by pushing or pulling upon the wheel attached to the end of the bamboo rod *D*, while turning the wheel operates the rear vertical rudder *J*. *G* is a rear elevator used to afford additional stability, and *I* is a triangular stabilizing surface in the front elevator. The bamboo rods *A A* to the rear supplementary surfaces and *C C* to the front supplementary surfaces can be readily unshipped and swung against the main surfaces for storage or shipping. All stay wires are stranded, no individual wires being used.

The motor develops about 30 horsepower and drives a single, 6-foot, two-bladed wooden propeller mounted directly upon the rear end of its crank-shaft. It is a remarkable fact that the best results have been secured, and a world's record broken, with a simple, "straight-pitch" type of propeller.

ends of the main planes and with their centers aligned with the two end pairs of main-surface struts, so that these balancing planes extend farther to the sides than any other parts of the machine.

As the machine stands on the ground the angle of incidence of the chords is about 6° . This is but little reduced when the machine is in flight.

The main surfaces are separated $4\frac{1}{2}$ feet by six spruce struts along each edge, one for every four spaces between ribs except at the center and ends, the latter overhanging the end struts 18 inches and the center space having five rib-openings between struts. All rectangles thus formed are rigidly braced by stranded diagonal wires. From the top and bottom of each of the four struts at the corners of the center section, two similar 12-foot bamboo members are carried forward and rearward to junctions with the sides of the front and rear elevators, which are pivoted at these junction points. The ends of the front elevator are of crossed steel tubes, with the pivotal points well forward, under the center of pressure.

From about the centers of the rear pair of extra struts in the middle of the main surfaces, two of the heaviest spruce members (about $1\frac{1}{4} \times 2$ inches) used in the machine extend downwardly and forwardly to a junction with the axle ends of the front wheel of the running gear—about 5 feet in front of the front edge of the main surfaces. These members are attached to the front pair of extra struts, immediately in front of which the seat is



FIGURE 192.—Details of Wright Biplane Strut Connections. Note the manner in which the struts *c* are fastened in U-shaped metal sockets at the center of the machine and hooked to the wing bars *a* in the flexible wing ends. The plate *d* indicates the point at which the wings unship for convenience in shipping and storing, while *b b* are the double rib members.

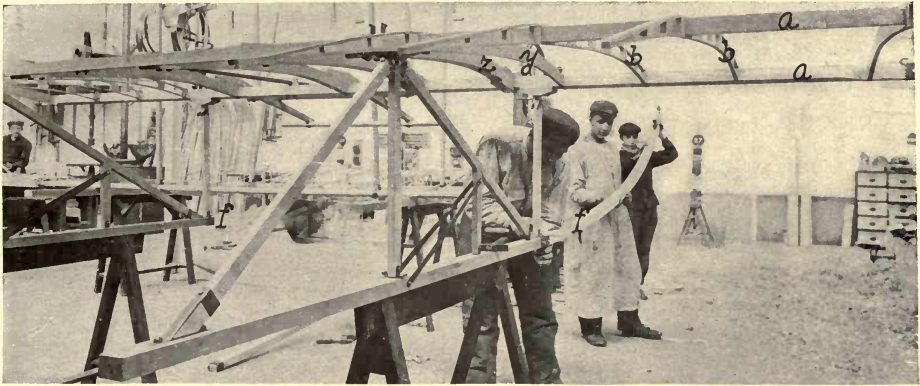

FIGURE 193.—The Wright Runner Construction. The solid ribs *yz* serve to support the motor, operator, etc. The other ribs *bb* are so built up as to enclose the wing bars *aa* between the double surfacing of fabric. The attachment of the forward curved members of the runners at *f* is clearly apparent upon close examination.



FIGURE 194.—Side View of Wright Runner Construction. The reference lettering is the same as in the preceding.

placed for the operator, with a foot rest in front of the seat.

The front wheel of the running gear is carried in an ordinary bicycle fork, and is additionally braced by a vertical member from this fork to cross members between the four bamboo braces of the front-elevator support. These two cross members are in turn braced by vertical side bars between their ends, tying together each side pair of bamboo elevator braces. Two struts also run, one from each side of the front wheel, forward to a cross tie about 18 inches from the juncture of each side pair of elevator braces.

The rear wheels of the running gear are located under the rear center pair of main frame struts, in bicycle forks, and are stayed laterally and fore-and-aft chiefly by framing of light steel tubes. From the center of this steel frame a wooden bar runs forward to the front wheel. Light wooden runners, to protect the lower wing ends in landing, are placed under the end pairs of struts. All parts of the framing are liberally wire-braced.

Control of height is by a bamboo steering pillar running from the steering wheel to the center front strut of the front elevator, this strut rising above the upper elevator surface to hold the front edge of the triangular steadying surface, previously mentioned. Pushing or pulling on the steering wheel causes the machine to descend or ascend. Turning the steering wheel operates the vertical rear rudder through a wire cable running in a groove in the rim of the wheel. The balancing

planes are worked by swinging the body sidewise in a steel crotch, the side of the planes lifted being the side swung away from.

A spoon brake applied by a bamboo plunger to the tire of the front wheel permits quick stopping after alighting and holds the machine for the start.

FARMAN BIPLANE

This biplane—shown in Figures 81, 143, 207, and 208—in a general way copies the earlier Voisin constructions (see Figures 174, 204, and 205), from which it was developed by the addition of the hinged ailerons *a a a*, Figure 142, the removal of the vertical panel surfaces, and the combination of runners with the wheeled alighting gear.

LANGLEY MACHINE

In the opinion of many who should know, the large Langley double monoplane, which plunged in the Potomac because of defects in its starting gear after similar models had proved thoroughly operative, is quite capable of flying in calm weather—with probably some doubt as to its ability to land otherwise than on water without a smashup. Its details were simply elaborations of those shown in Figure 70, but its reconstruction in the present era of better proved fliers could possess only technical, rather than practical interest.

LILIENTHAL'S MACHINES

These machines, like those of Chanute, Langley, Pilcher, and Maxim, are now properly to be

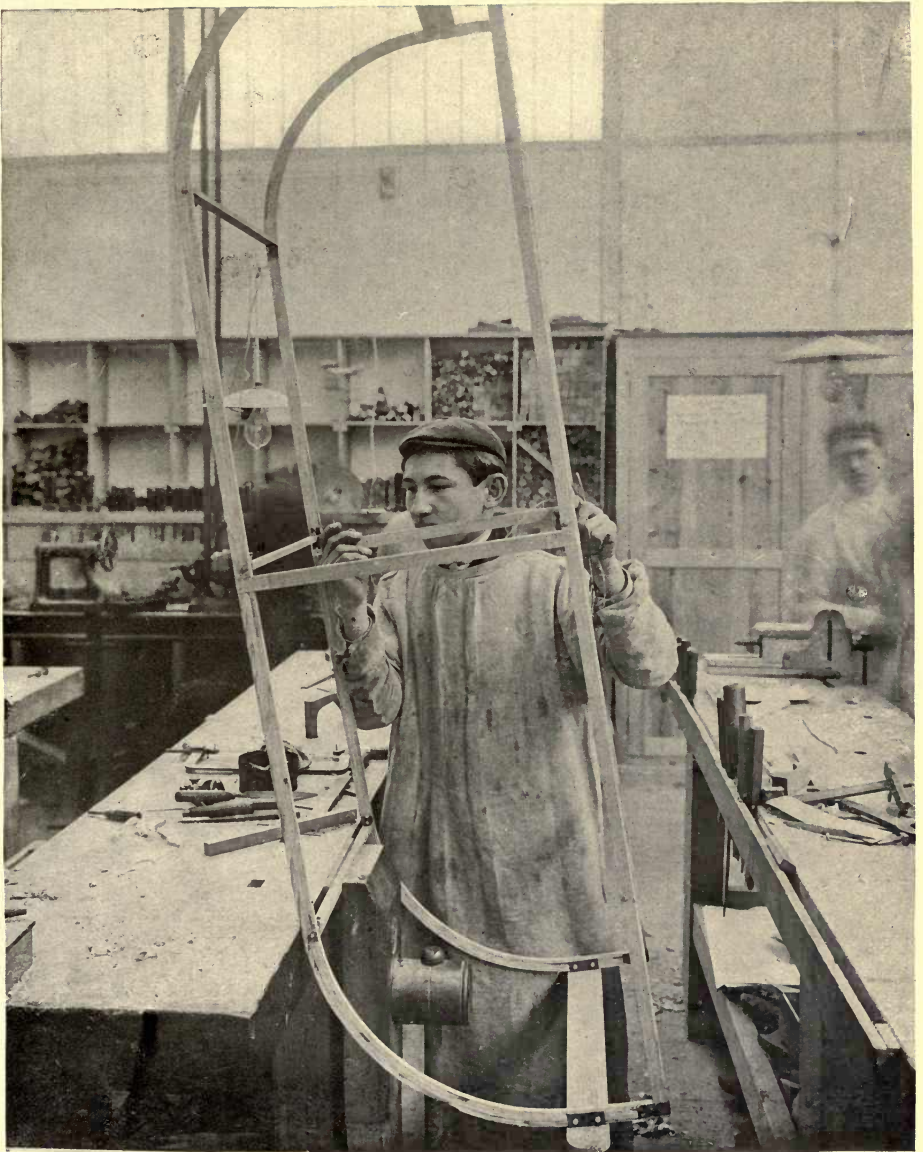

FIGURE 195.—Rudder Frame of Wright Machine.



FIGURE 196.—Elevator Frame of Wright Machine.

regarded as successful only from the standpoint of past rather than of present achievement, so, though they flew, and under certain conditions flew moderately well, they cannot be said to possess any features that would warrant further experiment with



FIGURE 230.—Early Lilienthal Monoplane Glider.

them. The earlier Lilienthal gliders were monoplanes, illustrated in Figures 230 and 231, and

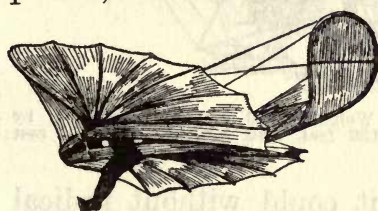

FIGURE 231.—Lilienthal Monoplane Glider.

with details given in Figure 263, but the final construction was the biplane sketched in Figure 232. This cannot be said to have proved any great merit

up to the time of the accident that resulted from it, though it was the final form to which Lilienthal had evolved his ideas.

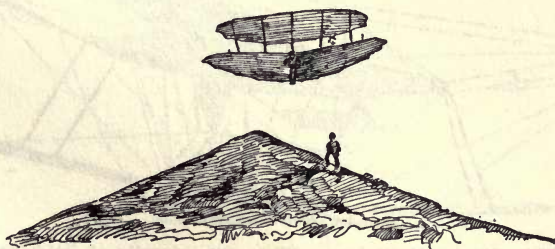

FIGURE 232.—Lilienthal's Biplane.

MAXIM MULTIPLANE

This great machine, the heaviest ever built, proved quite capable of lifting its weight, but there is little reason now to suppose, in the light of more

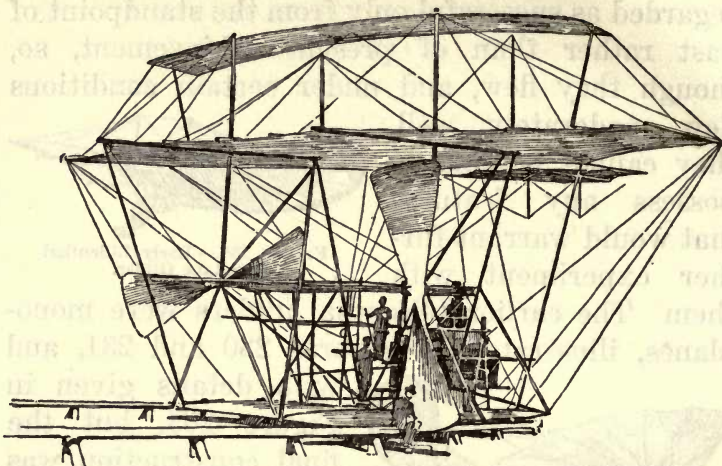

FIGURE 235.—Maxim Multiplane. Weight 8,000 pounds. Propelled by 363-horsepower steam engine. Span 126 feet, area 4,000 square feet, cost \$200,000.

recent knowledge, that it could without radical modification have accomplished controlled and continued flight. Its general appearance is very well suggested in Figures 235 and 236.

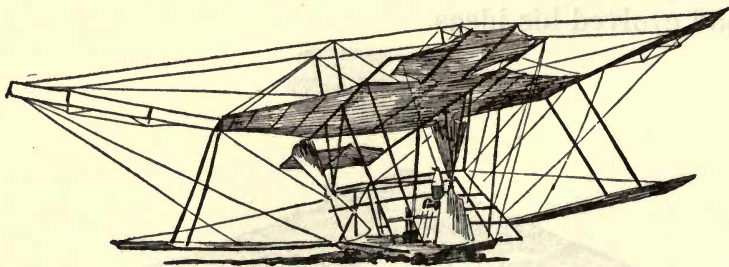

FIGURE 236.—Maxim Multiplane. When run on rails at Baldwin's Park, England, July 31, 1894, at 36 miles an hour, this machine lifted so much more than its weight that it broke a set of rails provided to hold it down and thus demolished itself.

MONTGOMERY MACHINE

This glider is of such absolutely proved capabilities, and is designed upon such sound prin-

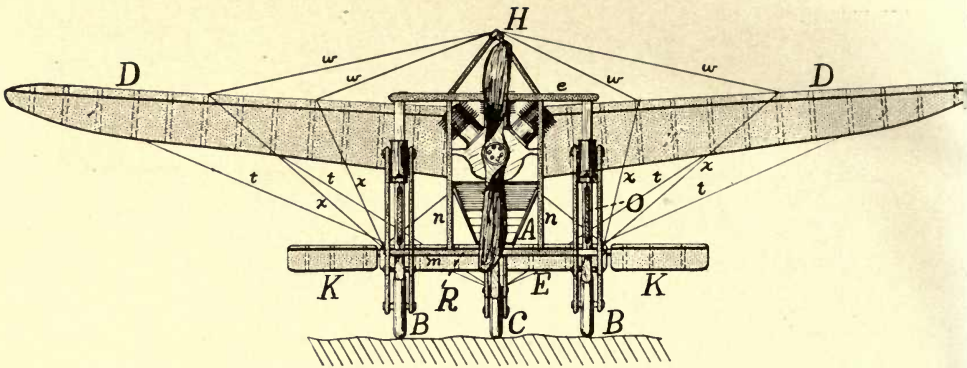
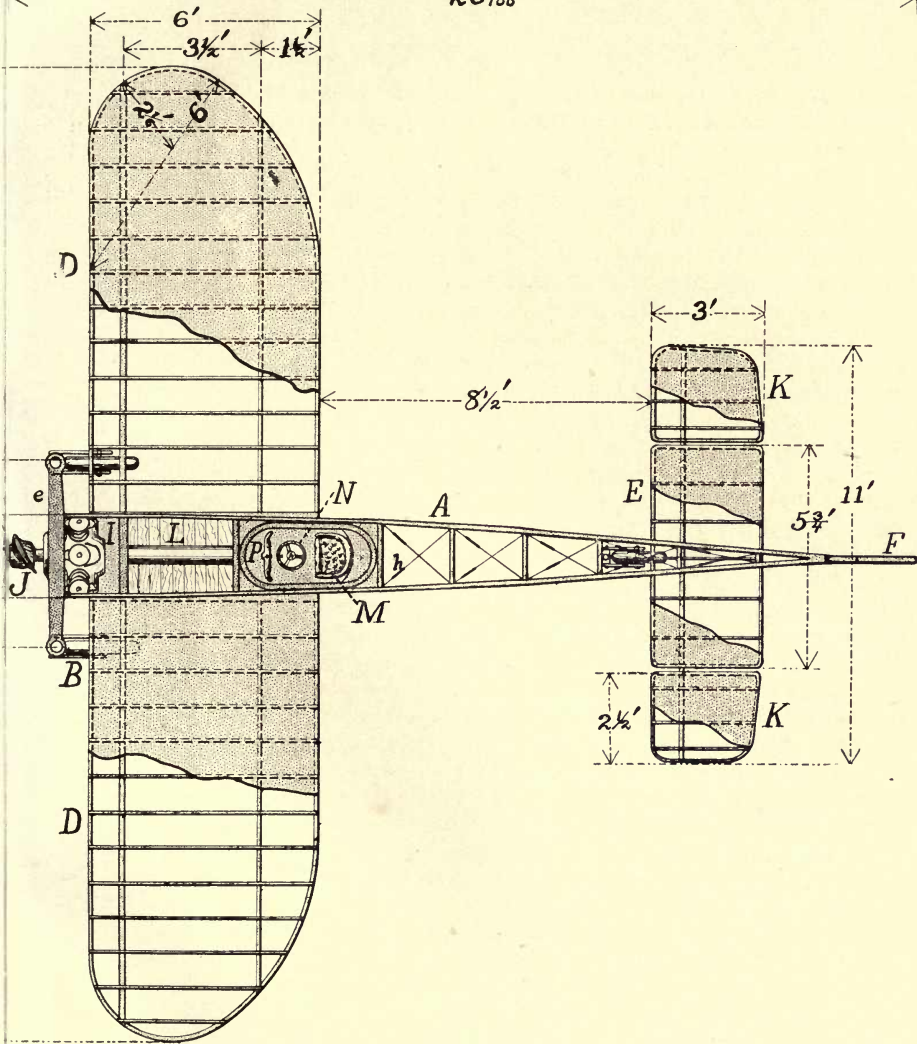
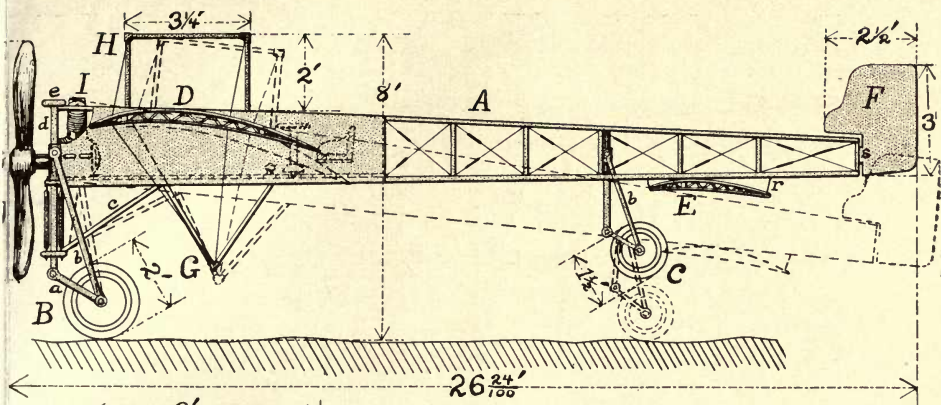

FIGURE 197.—Scale Drawings of Bleriot Monoplane Number XI. Besides being one of the most successful of present-day fliers, this machine is a comparatively simple and inexpensive one to build. The main element is the *fuselage*, or frame, *A*, which is simply built of four main members of poplar, separated by transverse bars spaced at regular intervals, and the whole rigidly trussed by diagonal wires *h* crossing all rectangles. This frame is of largest size at the front and in its vertical aspect tapers to a thin edge at the rear, but in its side aspect the taper is not so great. The wings *DD* are double surfaced, with the wing bars inside the double ribs, and the ends are rounded—more from the rear than from the front. They are demountably attached to the sides of the body, which in its forward portion is covered with fabric but at the rear is left open. The front edges of the wings are rigidly stayed by flat steel tapes *w w w w* and *x x x x* (not wires) to the overhead framing *H* and to the chassis. The rear edges can be differentially warped by pulling on the wires *t t t t*, which are attached to the pedestal *G* and operated by the wheel *N*. The rear rudder *F* effects horizontal steering, and is controlled by the pedal *P*. Vertical steering is by the rocking tips *KK* of the rear surface *E*. The starting and alighting gear consists primarily of the two fixed wheels *BB*, which swing on the links *aa*, against the rods *CC*. They are strained down by elastic springs, which absorb the shock in landing, but their downward movement is limited by leather straps. It is to be noted, in the construction of the chassis, that the front of the frame *A* rests upon the two rods *NN*, which are crossed at top and bottom, respectively, by the bars *em*, these bars carrying at their ends the vertical wooden columns on which the sleeves at the tops of *bb* slide. The single rear caster wheel is mounted to absorb shock by the action of a device closely resembling that employed for the front wheels. Propulsion is by the single wooden tractor screw *J*, $6\frac{1}{2}$ feet in diameter, and mounted directly on the engine shaft. The engine shown is the three-cylinder, V-shaped, air-cooled Anzani, of 22-25 horsepower, with which the crossing of the English Channel was accomplished, but many other motors have been successfully used on the same machines. The pilot's seat at *M* is comfortably located in a small cockpit, as shown. In the side view, the machine is shown in its flying attitude, its ground attitude being indicated by the dotted lines. The machine operates very successfully as a road vehicle with the wings dismounted and tied against the sides of the frame, steering being them effected by the rudder *F*, the surfaces *EKK* keeping the rear end off the ground. Dimensions are given in feet and fractions of feet.

25 ³/₁₀₀ 5



inciples, that with substantial construction and proper precautions it is probably one of the safest of all machines with which to practise flying. The drawing and details given in Figure 225 do not conform in certain minor measurements, proportions, and details to the machines used in the California flights, but have been compiled from a copy rather hurriedly built by the writer for personal experiment. They are close enough, however, to the description of Montgomery's own machines, as illustrated in Figures 226 and 227 and in the patent drawings in Figure 260, to supply a basis from which the cautious student will be able to secure remarkably successful flights if he will develop the apparatus and his own abilities in a conservative manner, preferably by practise over water. This machine being a patented device, no one can reproduce or use it unless prepared at any time to prove that such reproduction or use is solely for experimental purposes, with a view to improvement.

PILCHER GLIDERS

Judged by most of the results obtained, especially when flown kitewise by towing through the air



FIGURE 233.—Pilcher Glider. The "Hawk."

at the end of a cord, the later Pilcher gliders, sketched in Figures 233 and 234, were very safe in calm weather. Even the tragedy that resulted in the death of their designer was definitely due to a breakage, rather than to any fault fairly ascribable to the principle of the machines, though they

lacked the stabilizing and balancing elements of current constructions.

R. E. P. MONOPLANES

These machines, which have sustained more weight per unit of area than any other built, and on occasion have proved excellent fliers, are still



FIGURE 234.—Pilcher Gilder. The "Hawk."

the subjects of frequent modification and much experimenting by their designer, Robert Esnault-Pelterie, besides which they are rather difficult to build. For these reasons no drawings are given of their construction, but the views in Figures 119, 222, 223, and 252 have been selected with the special purpose of conveying a clear idea of their essential details.

SANTOS-DUMONT MONOPLANE

This wonderful little machine, of well-proved flying capabilities, is perhaps more to be commended than any other to the attention of those who may wish to reach results at the least possible expense and with a minimum of experimenting. Moreover, Santos-Dumont has unselfishly refused to patent any of the details on which he might have secured protection, frankly desiring that the widest possible use be made of his work. In addition to the working drawing and details in Figure 221, Figures 102, 116, 141, 217, 218, 219, 220, and 238 should be studied as examples of Santos-Dumont's experimental and final constructions.

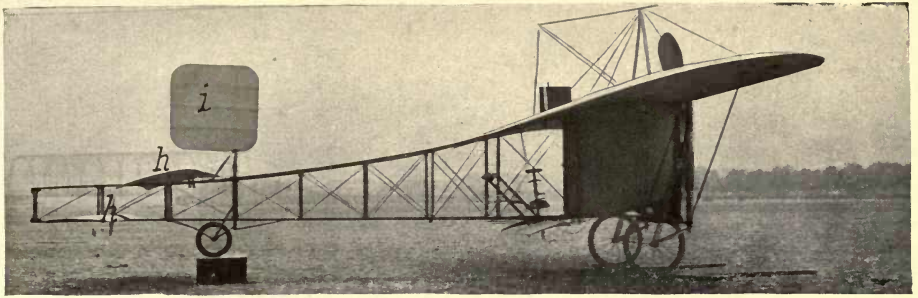

FIGURE 198.—Bleriot Monoplane Number XII.



FIGURE 199.—Bleriot Monoplane Number XI.

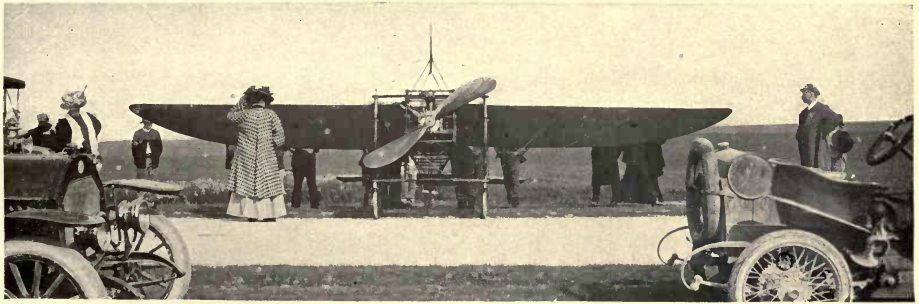

FIGURE 200.—Front View of Bleriot XI.

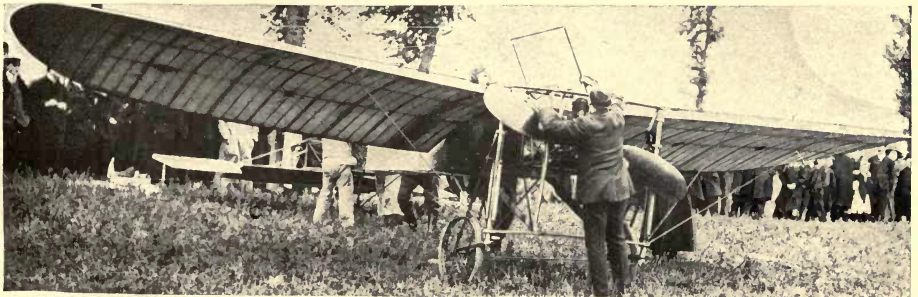

FIGURE 201.—Three-Quarters View of Bleriot XI.

VOISIN BIPLANE

The Voisin biplanes are almost as simple and stable as the box kites that they so closely resemble, besides which it is probably the case that they constitute the least patented and the least patentable of all constructions. For this reason anyone who may choose to work from the drawings and details given in Figures 206, and 172, 204, and 205 can do so with the assurance of reaching a successful result with a minimum conflict with patent rights.

WRIGHT BIPLANE

This widely known machine was for a considerable time by far the most successful of all power-driven aeroplanes, especially in the hands of a thorough expert in its use, besides which it is quite simple and inexpensive to reproduce. The Wrights, however, very positively assert the broadest possible claims on its construction, and at present evince a disposition to prevent the commercial exploitation of all machines not of their design or manufacture. The essential details of the most modern type of Wright biplane are, however, given in Figures 110, 134, 161, 163, 165, and 166, and in Figures 185 to 196, inclusive, it being supposed that the reader will use his own judgment about avoiding possible infringement. The exact wing curves of the Wright machines have not been published, but it is known that in successful models they are parabolic, with the chord very long in proportion to the focal length.

CHAPTER THIRTEEN

ACCESSORIES

In considering the development of aeronautical mechanisms, it is evident that besides the flying mechanism proper there is inevitably involved an increasing number of one kind and another of accessory devices, most of which will have to be especially devised or adapted for the new needs.

Many of these accessories in themselves present problems demanding the best efforts of the ablest investigators. For example, the necessity for the strongest possible lights, to penetrate great distances into foggy atmospheres, the need for devices for keeping track of speeds and distances traveled, and particularly to aid in the maintenance of straight courses against tendencies to lateral drift, are most apparent. In addition to these there is the more perfectly met requirement of means for indicating altitudes, temperatures, etc.

LIGHTING SYSTEMS

Naturally, in casting about for means of illumination and light projection suitable for application to aerial vehicles, the most valuable suggestions are in a majority of cases to be derived from the automobile.

Thus it is found that the various types of acetyl-

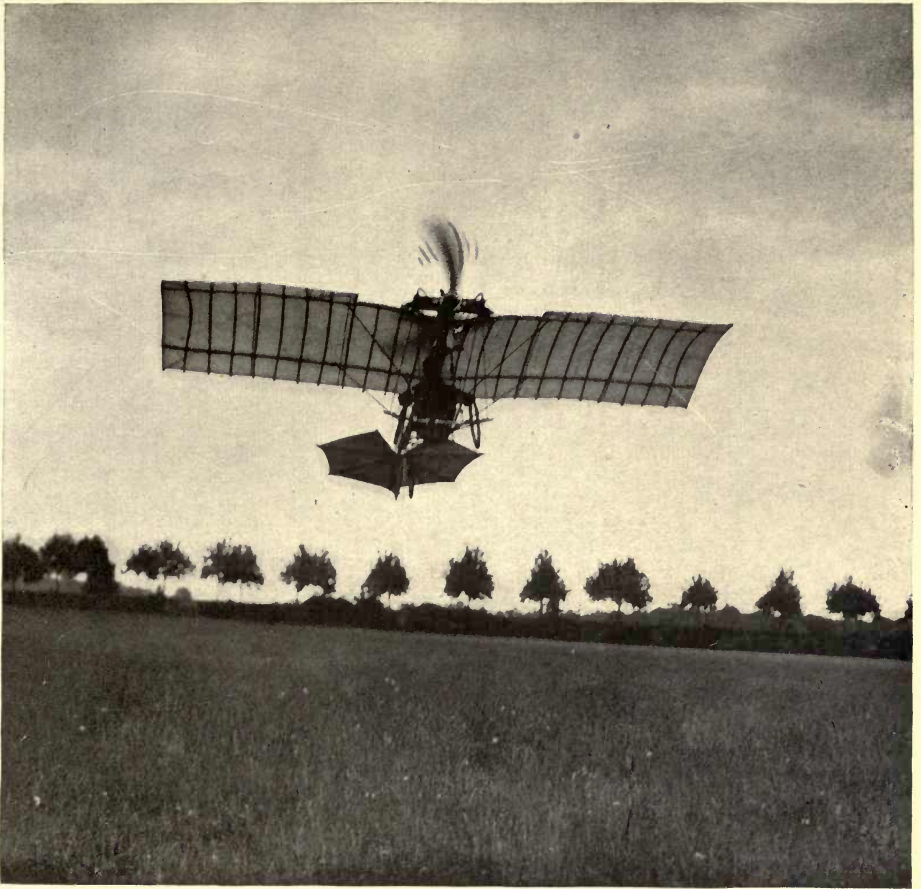

FIGURE 238.—Santos-Dumont's "Demoiselle" in Flight.

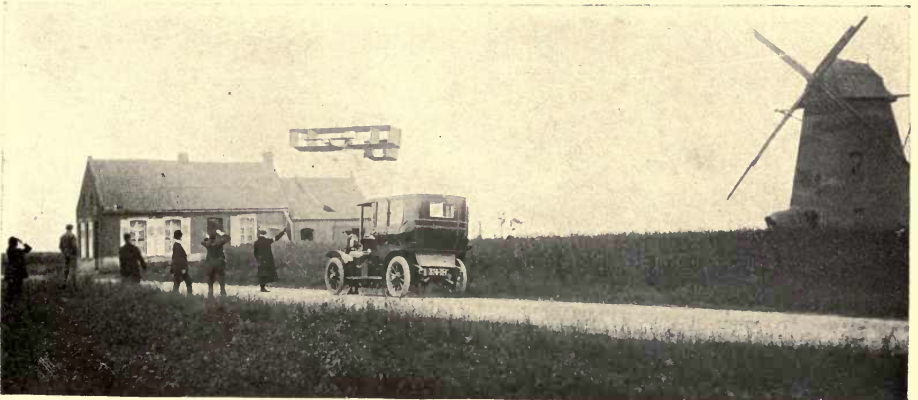

FIGURE 239.—Paulhan's Voisin in the Douai to Arras flight. This flight, over a distance of $12\frac{1}{2}$ miles, was performed on July 19, 1909, in 23 minutes.

ene lighting systems—oil lamps, electric lamps, etc., found suitable for automobile use—can be more or less readily applied to the newer purpose, the chief difficulty in the way of making such application entirely satisfactory being the necessity for even greater light-giving power with an absolutely-minimized weight.

ELECTRIC LIGHTING

Electric lighting so far has not been extensively applied to automobile illumination, though it is rapidly increasing in vogue.

This appears to be mainly because the storage battery is too decidedly heavy as a source of sufficient amounts of current—a difficulty that in its present development condemns it utterly for application to aeronautical vehicles—while the difficulty of running a dynamo from a connection with the variable-speed engine that must be used for propelling the car, without at the same time getting into most serious problems in the direction of current regulation, is the other of the two great difficulties that beset the application of electric lighting to automobiles.

Advantages of Uniform Motor Speed, such as seems invariably to be required in the use of any aeronautical engine, go a long way to relieve the electric dynamo from the shortcomings and disabilities that it is found to possess in attempted applications to automobile lighting.

Arc Lamps constitute the most concentrated and efficient of all devices for utilizing electric cur-

rent to produce light, though they hardly can be considered the most convenient, since for their successful operation the maintenance of the arc in the focus of a paraboloid mirror must be secured either by frequent hand-adjustment or by complicated automatic adjustment.

Incandescent Lamps are far and away the most convenient, simple, and reliable of all forms of electric illumination, and in the modern metallic-filament lamps—the tantalum and particularly the tungsten—are remarkably efficient, some modern tungsten lamps consuming little more than one watt of current to the candlepower. By the expedient of closely-coiling the filaments, the light source in an incandescent lamp can be very closely located in the focus of the mirror or lens, thus securing a more concentrated and powerful beam with less actual candlepower than is required with most other types of lamps. Another advantage, in providing against burned-out lamps, is that replacements are very light to carry and are readily placed in the sockets.

An objection to the tungsten lamp in ordinary uses is the fragility of the filament, especially in lamps of high candlepower worked on high voltages—involving very long and fine filaments. Tungsten lamps for automobile service, however, have been made very substantial simply by virtue of the shortness and thickness of the filaments suitable for operating with the low candlepowers and from the low voltages commonly used. With the dynamo as a source of current, as seems the likely develop-

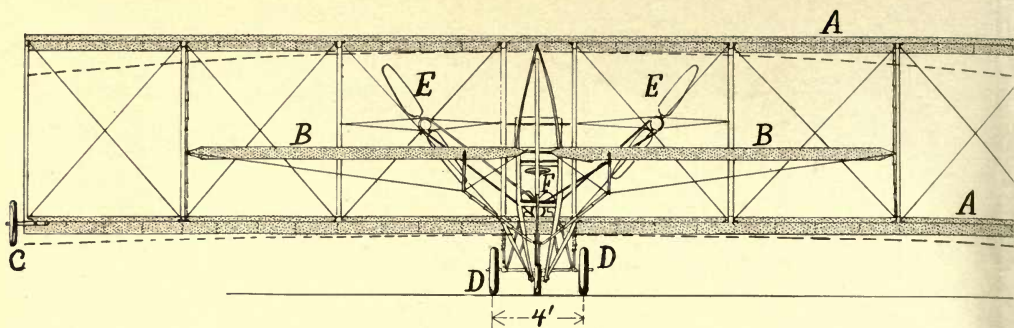
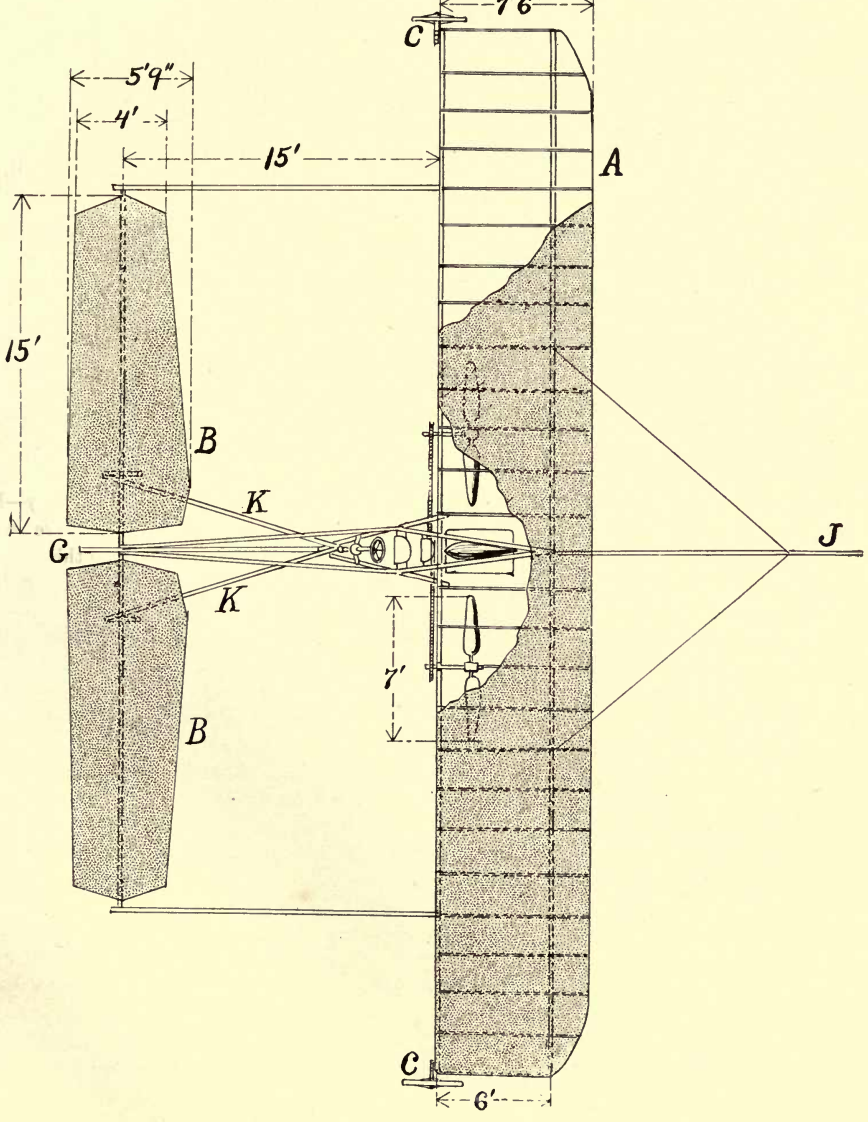
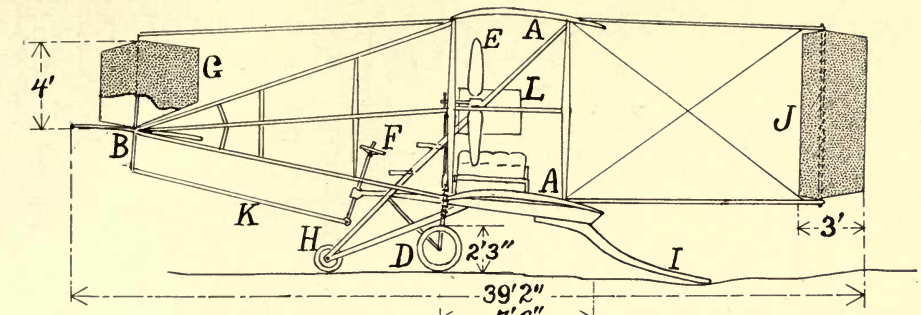
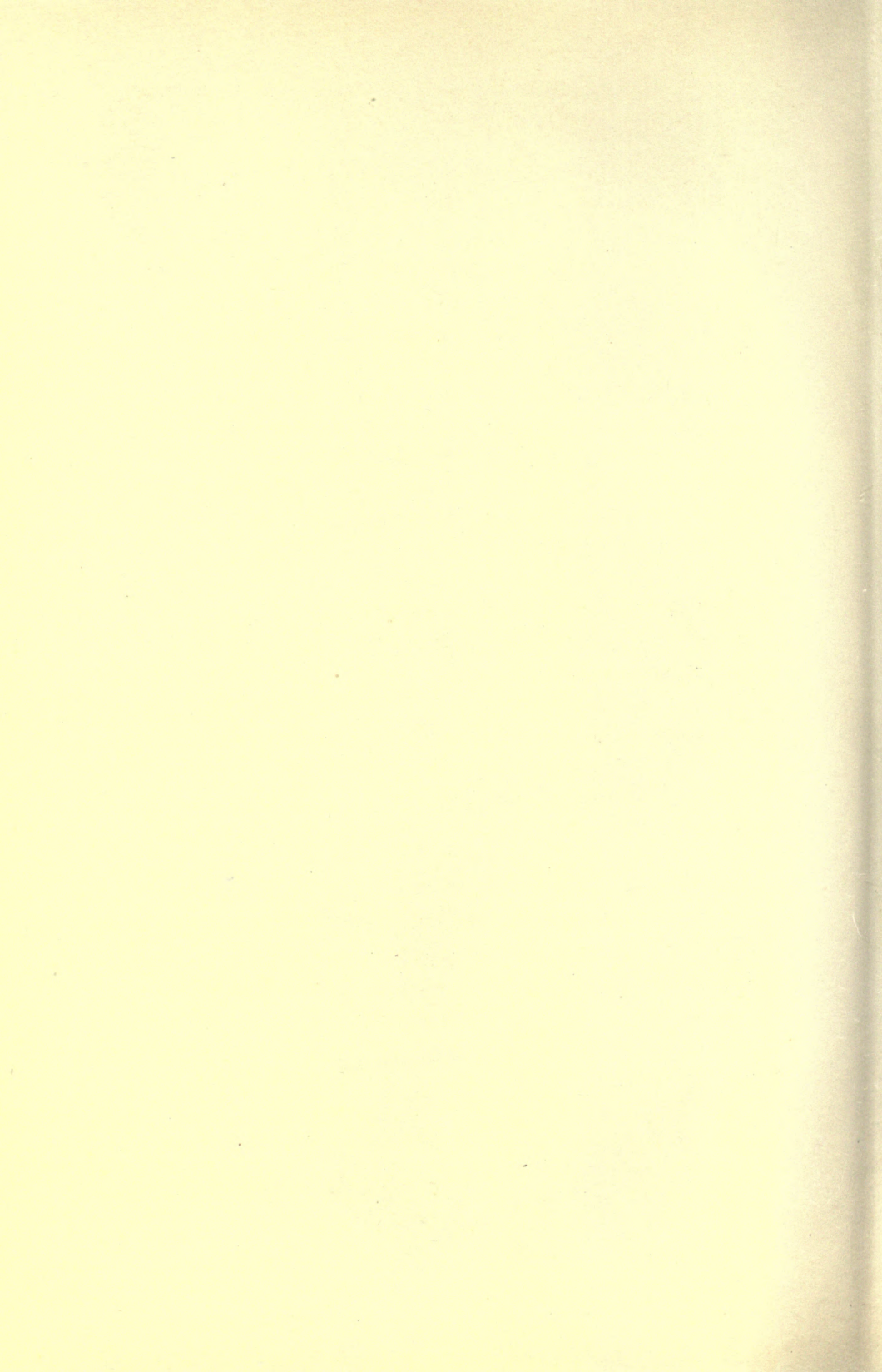

FIGURE 202.—Scale Drawings of Cody Biplane. This machine, though an excellent flier, is so large and cumbersome that its reproduction is hardly a task for the amateur—unless a reduced copy is undertaken. In its general details, this biplane is very closely patterned after the Wright machine, with numerous differences in minor particulars. The main planes *AA* are double surfaced, built-up ribs that enclose the wing bars in such manner as to avoid the possible resistances that may be set up when these are exposed. In trussing up the wings, the best results are secured with a pronounced droop or arching of the surfaces, as is suggested by the dotted lines in the front view. The arching is greater for the upper surface than for the lower. The end ribs are of flatter curve than those nearer the center, much as in the Montgomery glider, and to this feature doubtless is attributed the speedy flight of which this biplane is capable, in spite of its combination of great weight with not extraordinarily high power. Lateral balance is maintained very peculiarly—by differential manipulation of the rocking elevator surfaces *BB*, which when worked together serve merely to raise or lower the machine up or down, but which otherwise tilt the machine to right or left. In addition to this means of controlling wing warping has been successfully applied, as also has been the use of ailerons. In fact, all means have been experimented with, both independently and in various combinations. The operation of the *BB* is by the control rods *KK* which move in unison with a forward or rearward swinging of the steering pillar and oppositely when the wheel *F* is rotated. The vertical surface *O* is simply a stabilizing surface, but the single rear rudder *J* is pedal controlled and serves to counteract the lag of the outer side of the machine in turning. Propulsion is by twin propellers *EE*, oppositely revolved, on a crossed-chain driving system practically identical with that used by the Wrights. The chains are specially built by an English chain manufacturer to provide the lateral flexibility desirable for attaining the best results with crossed drive. The starting and alighting gear consists of a three-wheel chassis *DDH* and the springy wooden skid *I*. Wing wheels *CC* are used at the ends of the main surfaces to protect them from damage in case of sidewise tilting in landing. Liberal use of bamboo is made in the construction of the machine, but all bamboo spars are tightly wrapped with wire or wire between joints to prevent splitting. The weight of the finished machine, with fuel and pilot, is over a ton. The seat for the pilot is directly behind the control wheel, with that for a passenger somewhat higher and further to the rear. While it is not to be recommended that the average experimenter copy this particular aeroplane, there is no doubt but what its construction embodies many features of interest and value that might well be applied in smaller or modified machines. Furthermore, its great size constitutes a striking example of what can be accomplished in this direction, without introducing elements of uncertainty or of undue fragility. Dimensions are given in feet and inches.





ment in aeronautics, higher voltage seems certain to be desirable from most standpoints—lightness, efficiency, etc.—which may direct the use of tungsten lamps into rather fragile types. Against this, though, is the fact that in any type of flying machine there is no such jolting as exists in the case of the automobile, the machine riding on the air with almost perfect smoothness.

The Nernst Lamp, the current consumption of which is about 1.5 watts to the candlepower, is a sort of incandescent lamp of very remarkable design, in which the very short and thick filament is composed of oxids of some of the rare metals—principally zirconium and yttrium—is a good conductor of electricity only when heated, and is so refractory that it does not require enclosure in a vacuum to permit its use without burning out.

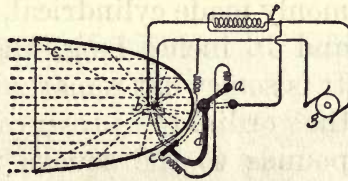

FIGURE 240.—Suggested Nernst Lamp. The glower *b*, at the focus of the paraboloid mirror *c*, receives current from the dynamo *g*, with the usual balancing coil in the circuit at *f*. The heating coil *e*, however, is mounted on the hand-manipulated arm *d*, so that it is shunted into the circuit by the switch *a* when it is swung up in proximity to *b*.

ACETYLENE

Acetylene is one of the heaviest and richest of all the hydrocarbon gases, making it exceptionally well adapted to the production of intensely-luminous flames with only small gas consumption. Acetylene is most conveniently produced by the action of water upon calcium-carbid, the reaction turning the calcium-carbid into quicklime—which

is slacked by the action of the water—while the carbon released from the decomposition of the carbid combines with the hydrogen released by the decomposition of the water to produce the acetylene.

Storage Tanks for transporting acetylene in manufactured form, dissolved under pressure in acetone, are widely used for automobile lighting and are exceptionally safe and convenient. Such tanks containing thirty cubic feet of gas are commonly made cylindrical, about 6 inches in diameter and 16 inches long, and weigh about 30 pounds. It is somewhat remarkable that such a tank, under the ordinary pressure of something like 225 pounds to the square inch, and first filled with asbestos or other absorbent material and enough liquid acetone to fill the tank full, will contain considerably more acetylene, dissolved in the acetone (like carbonic-acid gas in the water of soda-fountain beverages), than can be placed in the same tank empty. Also, while the gas compressed into the empty tank would be a very dangerous explosive, its storage in the acetone seems to make it perfectly safe, it automatically evaporating as required for use only as the pressure is released.

Acetylene Generators have the advantage over acetylene storage tanks that they are rather lighter for a given gas production than a tank for the storage of an equivalent amount of gas. There are two fundamental systems of acetylene generation—one involving the “carbid-feed” generator, and the other the “water-feed.” By all means the

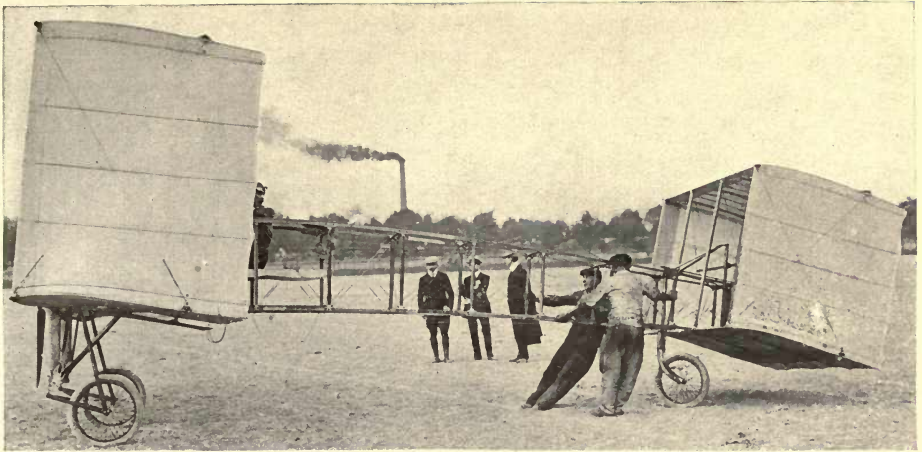

FIGURE 203.—Latest Model Voisin Biplane—With tractor screw and no front elevator.

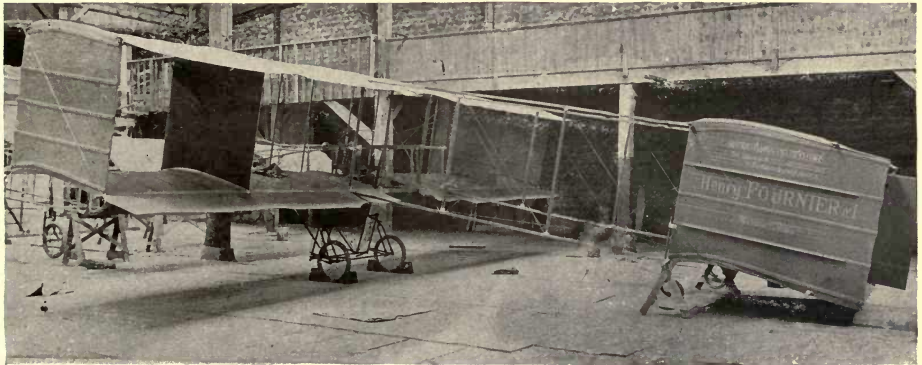

FIGURE 204.—Three-Quarters Rear View of Voisin Biplane.

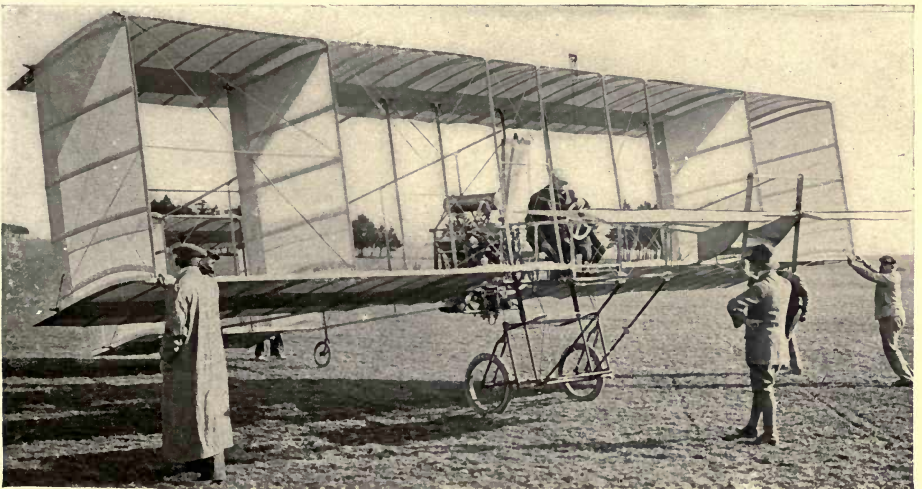

FIGURE 205.—Three-Quarters Front View of Voisin Biplane.

most successful type of automobile generator carries the carbid in a wire basket in the upper part of the container, with water above the basket and considerable receiving space below it for the reception of the slacked carbid which is jarred out between the wires. Such generators operate best when subjected to considerable shaking, making them even less available for aeronautical use than for automobile use, and are very prone to heat up, with a consequent production of tarry gas and much obstruction of piping by gummy deposits and condensed moisture.

Acetylene Burners require provision for admixture of the acetylene with a great excess of air, since otherwise a blue-flame or imperfect combustion results, but given sufficient air admixture combustion is attended with the production of an intensely luminous flame of great brilliancy, and of a quality more nearly approaching sunlight than any other artificial illuminant. The most widely used acetylene burners are of double-jet types, arranged to impinge two round jets upon each other at right angles—the two flattening at the point of juncture into a wide, flat flame.

Within the last year or so a new type of acetylene burner has come into use in which only a single flat opening is used, in a general way rather similar to the ordinary straight slit in common illuminating gas-burners but provided with several openings for the inspiration and admixture of the necessary air required, **without** the complication and objections that apply to the common type.

OXYGEN SYSTEMS

One of the oldest forms of very-concentrated high-power illumination is the calcium light, in which a small button of lime is heated to incandescence by the exceedingly hot blue flame from an oxy-hydrogen blowpipe. This particular form, which is still much used for stereopticon projection, especially where electricity is not available, requires to be modified to present any possibility of use from aerial-vehicle standpoints.

With Hydrogen it of course is necessary to carry a tank of hydrogen gas under pressure, as well as the necessary oxygen stored in the same manner.

With Gasoline, however, used from the regular supply for the engine, only an oxygen tank being carried, there have been developed quite satisfactory automobile headlights in which a jet of vaporized gasoline is burned in combination with a jet of oxygen, the regulation calcium button being used to produce the white and powerful light by its incandescence.

With Acetylene and oxygen it is possible to secure a blue flame stated by some authorities to be even hotter than the oxy-hydrogen flame, and therefore capable of producing an even more brilliant light in combination with the lime.

INCANDESCENT MANTLES

Incandescent mantles kept hot by a blue flame from a more or less modified form of Bunsen burner have within recent years become one of the

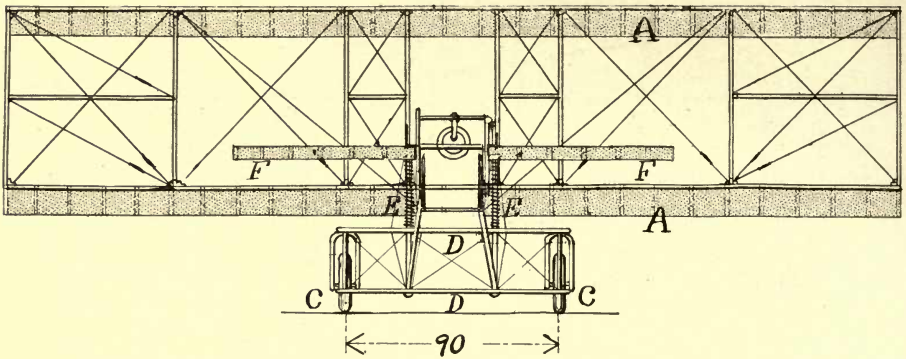
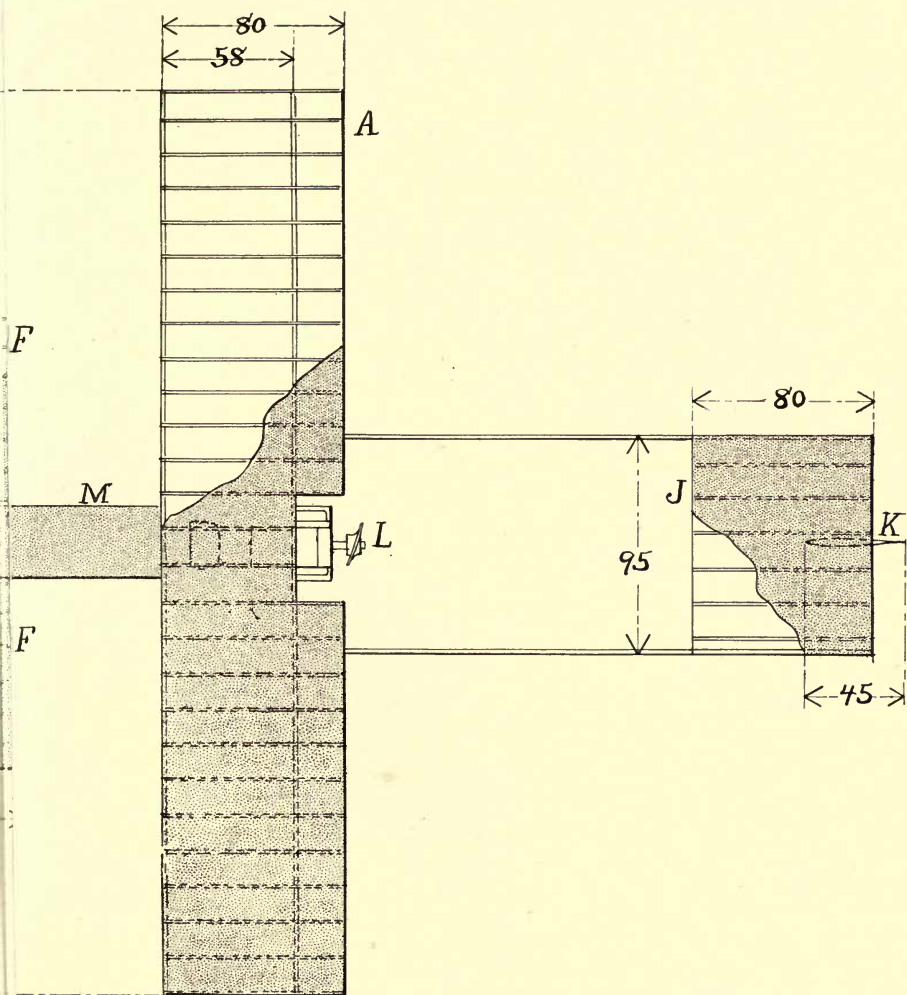
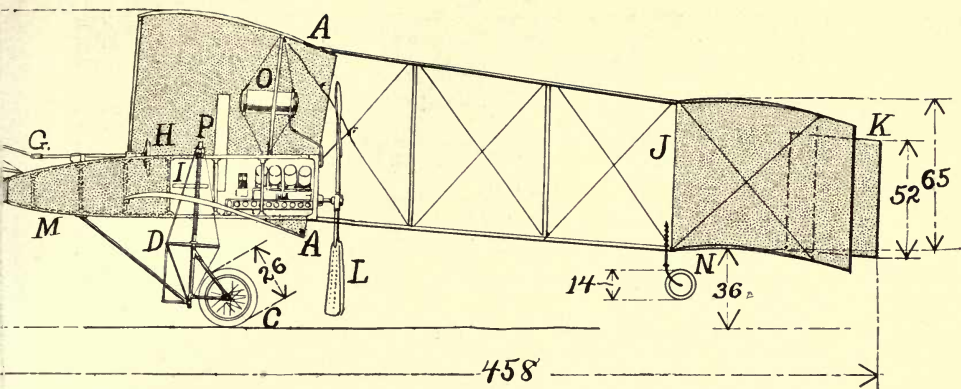
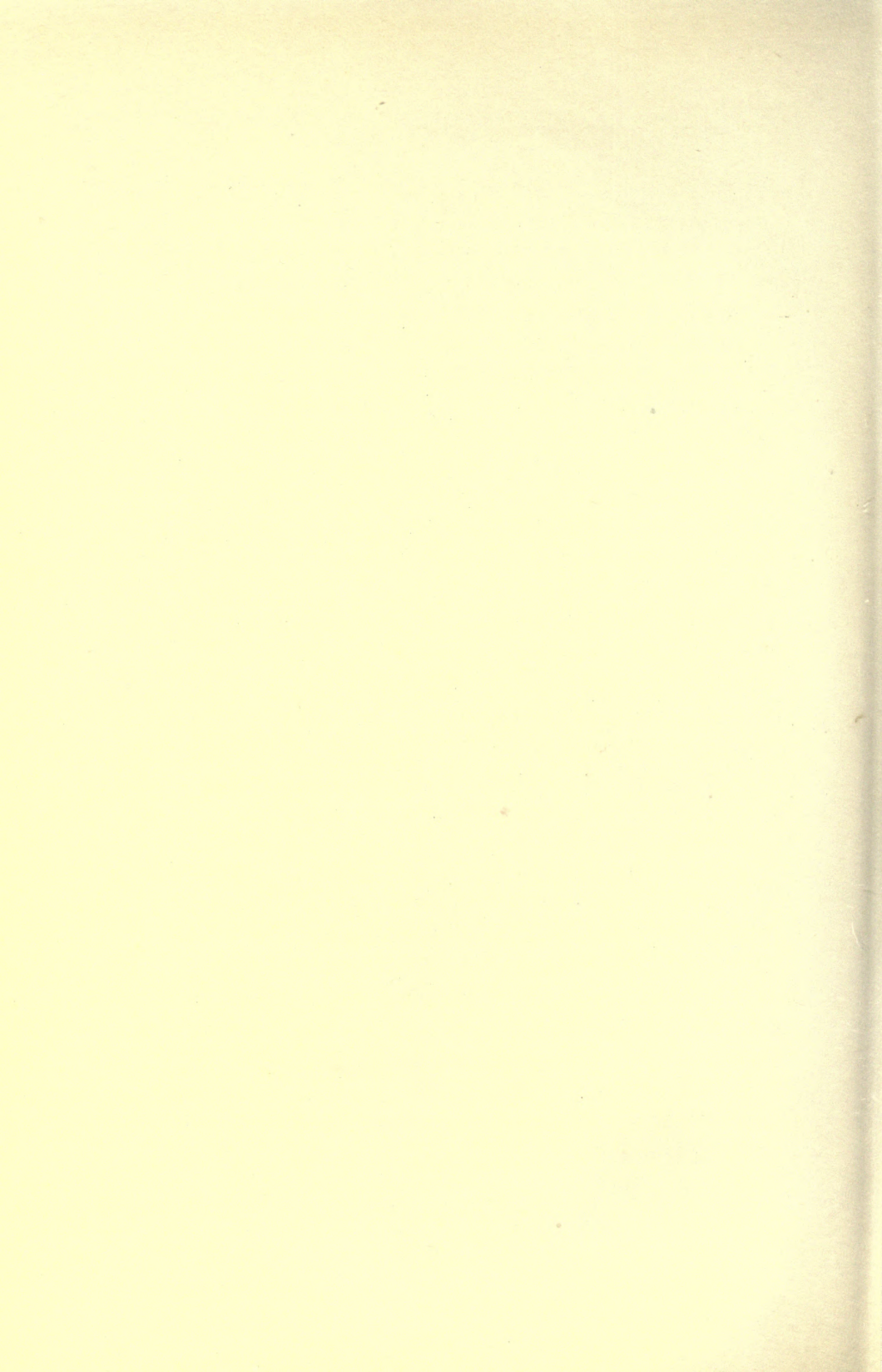

FIGURE 206.—Scale Drawings of Farman's Voisin. The main planes *A A* of this machine, which is of the characteristic Voisin construction, are double surfaced, over built-up ribs enclosing the wing bars. Lateral equilibrium is maintained wholly by the automatic action of the vertical panels between the ends of the main surfaces and those of the tail *J*. Horizontal steering is effected by the vertical rudder *K*, operated by turning the wheel *H*, but the machine can turn only in very wide curves. Vertical steering is by the front elevator, the two elements of which, *F F*, can be rocked only in unison by pushing or pulling on the wheel *H*, which connects with them through the hinged joint *G*. *M* is simply a forwardly extended framework, or prow, to carry *F F* and brace the alighting gear *C C D D*. This alighting gear consists of the two wheels *C C* rigidly mounted in the framework *D D*, which under shock rises as a unit against the springs *E E*. Two small caster wheels at *N* serve to support the tail *J*, which is merely a stabilizing element. An eight-cylinder, water-cooled, V-shaped Antoinette motor of 50 horsepower furnished the power in the particular machine described, in which the 7½-foot single propeller was mounted directly upon the engine crankshaft, but many different engines have been used in different Voisin machines, and in at least one instance flights have been accomplished with a geared-down propeller. The fuel tank is shown at *O*, the radiator at *P*, and the pilot's seat at *I*. Weights of different elements of a recent Voisin machine are as follows: Main surfaces, 180 pounds; chassis, 250 pounds; tail framing, 40 pounds; tail surfaces, 55 pounds; tail wheels, 13 pounds; vertical rudder, 10 pounds; elevator, 32 pounds; engine, 320 pounds; radiator and water, 80 pounds; pilot, 170 pounds—a total of 1,150 pounds. The area of the main surfaces is 445 square feet; of the elevator, 45 square feet; and of the vertical rudder, 16½ square feet. All dimensions are given in inches. For further details of the Voisin machines reference should be had to Figure 88, showing the frame of the newest biplane of this make, from which the forward elevator is eliminated; Figure 142, showing Farman's modification of the Voisin into a triplane; Figure 168, showing a machine of this type rising from the ground; Figure 172, picturing the Voisin alighting gear; Figure 203, showing the most recent model of this machine; and Figures 204 and 205, giving characteristic views of recent Voisins.







commonest of all means of illuminating buildings, streets, etc., and are in their best forms very effective, durable, and of sufficiently-concentrated intensity to permit of their use with reflectors.

Latterly the incandescent mantle has been very successfully applied to the illumination of railway cars, in which the jarring unquestionably is much greater than in aerial vehicles. Mantles for this purpose usually are made very small, of the inverted type, and, if necessary, as hard and almost as strong as porcelain.

With Gas, ordinary illuminating gas is preferable for ordinary use, chiefly because of its cheapness, but in railway cars the richer and purer hydrocarbons such as are supplied by the Pintsch system, in which acetylene is used in combination with other gases, are found most satisfactory.

With Liquid Fuels incandescent mantles can be operated very successfully, the best fuels being gasoline, alcohol, and kerosene, in the order named.

OIL LAMPS

That oil lamps are not without points of superiority over many of the most scientific and highly-developed methods of light production is rather evident from the fact that this in many ways primitive system, for such important services as railway switch lamps, signals, cars, lighthouses, etc., has been found more satisfactory than anything more modern.

Sperm Oil, with or without modifying admixtures, possesses certain points of superiority over

kerosene and other petroleum oils, for which reason it is much used in lighthouses, signal lamps, and for other purposes in which a high degree of reliability and cleanliness is sought.

Kerosene is superior to most other oils in its calorific value for direct combustion by the use of a wick, besides which it is universally available.

REFLECTORS

Since the light from most ordinary sources of illumination is more or less evenly cast in every

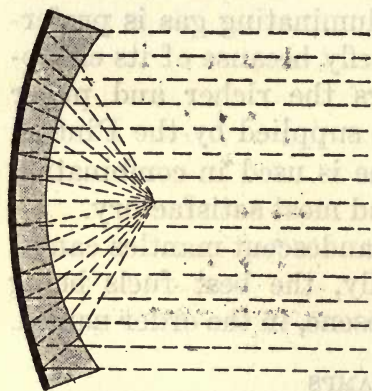

FIGURE 241.—Lens Mirror. Showing how the light from the focus is refracted by the glass and reflected by its mirror backing into a beam of parallel rays.

direction, its projection in a single direction, as is usually required for vehicle use, and as must be especially the case for aerial vehicles, requires the use of a refracting surface designed to collect and gather all the radiating rays as completely as possible into a compact beam of non-divergent parallel rays. In automobile lamps the so-called "lens mirrors" are chiefly used, being composed of glass lenses, parabolically curved in their sections and their rear surfaces silvered with a reflecting coating. Such mirrors naturally possess an immunity from tarnish, particularly with open flames, that is not possessed by metal reflectors. A typical lens mirror is shown in



FIGURE 209.—Side View of Maurice Farman's Biplane. This machine resembles both the Voisin and the Farman machines—the former in its running gear and the latter in the absence of the vertical panels.

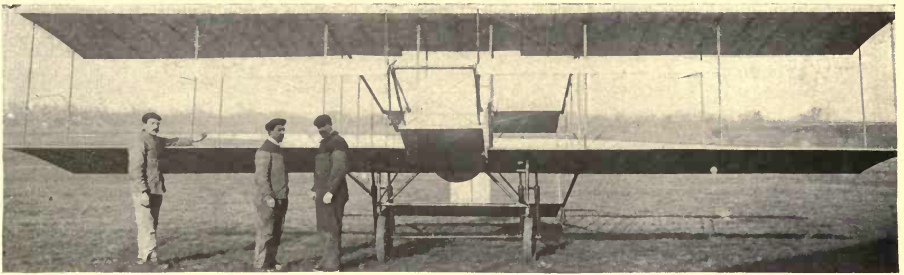

FIGURE 210.—Front View of Maurice Farman's Biplane.

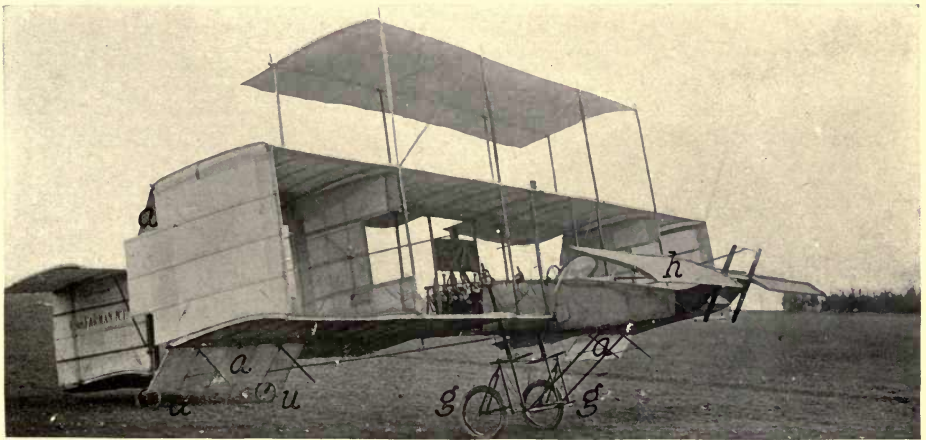

FIGURE 211.—Farman's Modified Voisin. Note the ailerons at *a a a*, and the added upper surface, making the machine a triplane.

Figure 241. Metallic reflectors, however, in deep paraboloid form, of the locomotive-reflector type, intercept and reflect in a desired direction a greater quantity of the light than any other type, especially if a plano-convex lens, Figure 242, is placed in front of the flame to gather the cone of rays that would pass out the end of the paraboloid.

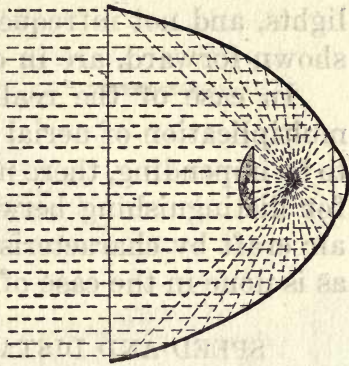

FIGURE 242. — Locomotive Headlight. All light rays not intercepted and thrown forward in a parallel beam by the paraboloid metal reflector are refracted by the plano-convex lens in front of the light source, the portion of the metal reflector behind this lens being made spherical so as to return the rays it receives back through the focus to the lens.

ARRANGEMENT OF LIGHTS

With all land and water vehicles, standard systems of lighting arrangements are established by custom and often by law. For example, all the world over, a modern automobile carries two front headlights (usually acetylene), often in conjunction with two oil or other side lamps showing a beam ahead as well as a less amount of light at the side, and a single red tail lamp. A single, powerful searchlight or projector, mounted high on the center of the dashboard, is often added for rough cross-country travel. For water craft the most usual requirement is that of a red light showing forward and to the port (left) side with a green light forward and to starboard (right), though various arrangements of masthead lights, stern

lights, and not infrequently powerful searchlights shown forward, are in extensive use.

In case of the really great development and multiplication of aerial traffic which many believe to be impending, there might be a further necessity for distinguishing between the lights of different air craft by characteristic arrangements of lights as is done in the case of ocean liners.

SPEED AND DISTANCE MEASUREMENTS

One of the greatest problems in aerial navigation is certain to be the correct or even approximately correct estimation of speed and distance. To begin with there is the sufficient difficulty of constructing any highly-accurate device for exactly registering the speed at which the air passes a given point, or, what amounts to the same thing, measuring the progress of any given point through the air. But in addition to this question there is the much greater one of allowing for the drift of the vehicle with the whole body of the atmosphere across the surface below—a drift that can add to or subtract from the speed of the vehicle over the earth's surface, or that can produce leeway drift far in excess of the most ever encountered in water navigation.

ANEMOMETERS

Anemometers, for the estimation of speeds through the air, will doubtless closely resemble the very valuable and satisfactory devices that are widely used by weather-bureau and meteorological

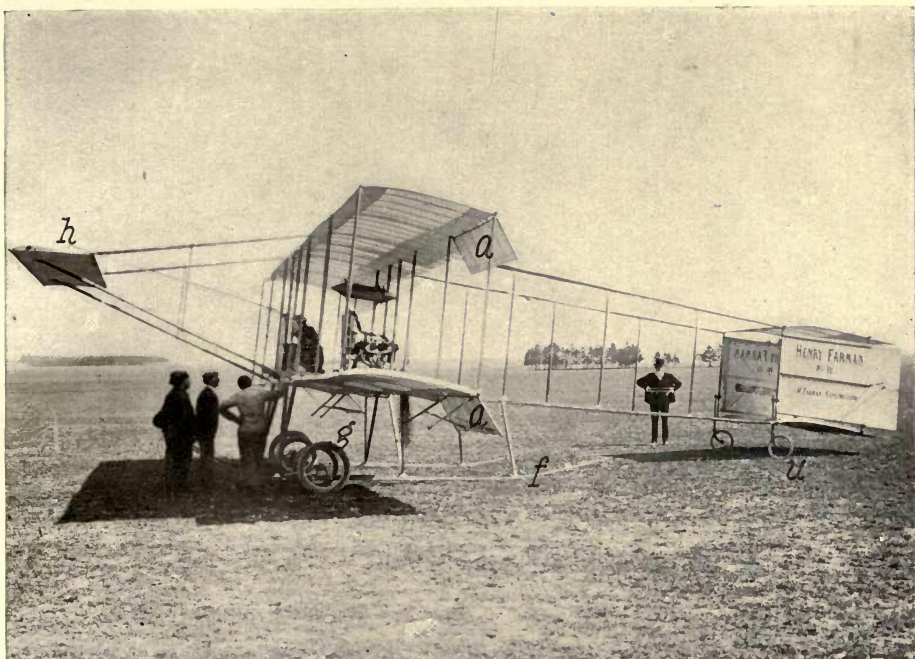

FIGURE 207.—Side View of Farman Biplane. This machine, which holds the world's distance and duration records, is particularly interesting because of the use of the wheels *g* in combination with the runners *f* in the alighting gear.



FIGURE 208.—View of Paulham's Farman Biplane, which made the London-Manchester cross-country flight of 180 miles.

stations for recording wind velocities. The commonest form is the four-arm type illustrated in Figure 243, with hemispherical cups at the end of each arm, the greater resistance opposed by the concave sides of these cups over that opposed by the convex sides causing variation in the speed of rotation that very closely approximates varia-

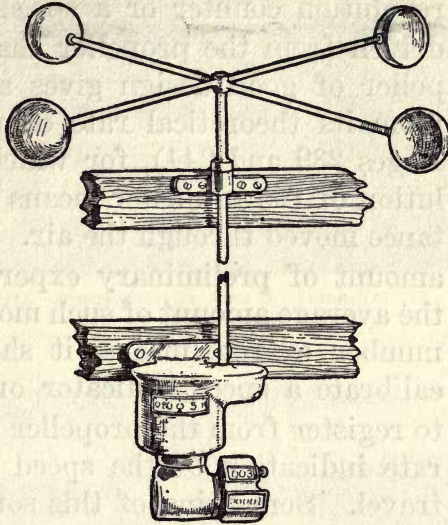

FIGURE 243.—Anemometer Speed and Distance Recorder. The cups, by the greater resistance of their concave over their convex surfaces, cause the vertical shaft to revolve at a rate proportionate to the movement through the air. The speed and total number of revolutions are shown in miles per hour and miles traveled, by the automobile speed indicator and the odometer at the base of the shaft.

tion in the movement of the air—or through the air. Another common form of anemometer is that in which a small windmill-like fan is revolved by the passage of the air through its vanes. This type always must be faced to the wind.

Either of the types of anemometer described can be connected up to ordinary speed-indicating or revolution-counting devices, as pictured in Figure 243.

MICELLANEOUS

Another possible method of keeping track of distance traveled through the air is simply by a

revolution counter or a speed indicator, or both, driven from the propeller shaft. An aerial propeller of good design gives a very uniform slip from its theoretical rate of pitch progress (see Pages 239 and 244), for which reason each revolution of the propeller means a quite definite distance moved through the air. So, with a sufficient amount of preliminary experiment to determine the average amount of such movement with a given number of revolutions, it should be possible to calibrate a speed indicator or revolution counter to register from the propeller turns a closely accurate indication of the speed and the amount of travel. Something of this sort is very commonly done in the navigation of steam vessels, the engineers of which invariably place greater reliance on the record of propeller revolutions than they do upon any other available means of determining speed or distance.

COMPASS

The magnetic compass, the use of which is contemporaneous with almost the earliest history of navigation, though its really scientific application is more due to the modern mariner, will undoubtedly serve a purpose in the aerial craft of the future, though in its application to these there are not to be overlooked some most serious difficulties.

The particular shortcoming of the compass as a useful adjunct to aerial navigation is that while it can be depended upon to show the different directions with absolute or approximate accuracy, it affords little assurance that the vehicle is really

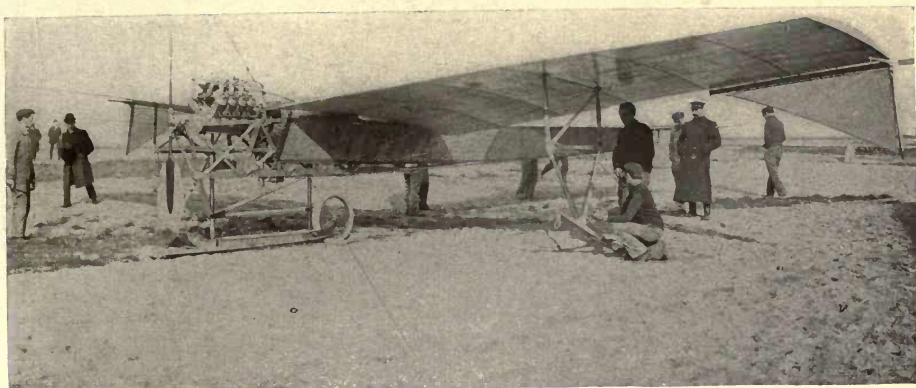

FIGURE 213.—Three-Quarters View of Antoinette III.

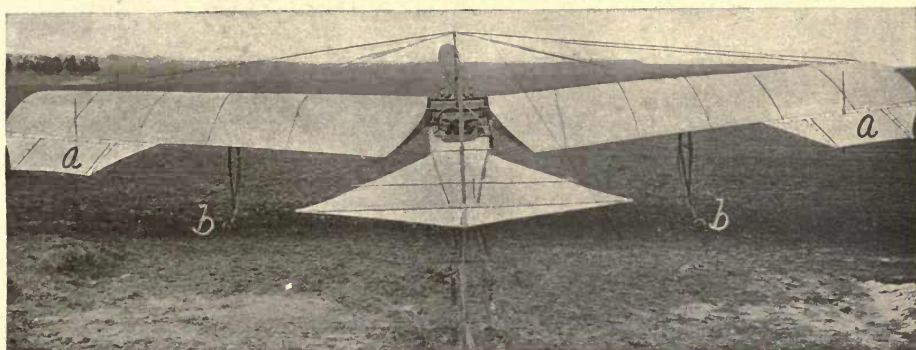

FIGURE 214.—Rear View of Antoinette V. In this view the ailerons *a a* and the balancing rollers *b b* are well shown.

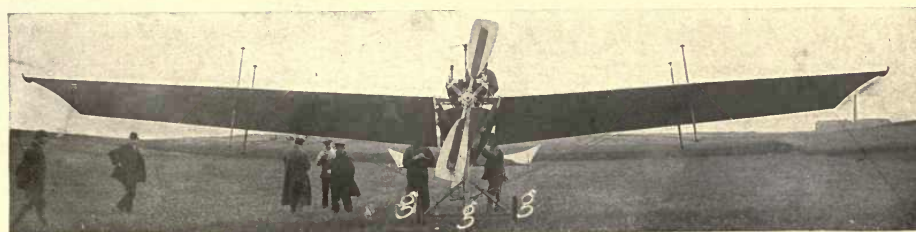

FIGURE 215.—Front View of Antoinette VII.



FIGURE 216.—Rear View of Antoinette VII. This is the machine with which Latham flew 20 miles in his second attempt to cross the English Channel. Ailerons are discarded in favor of rocking the whole wing, and the alighting gear is reduced to the wheels *g g g* and *u*.

progressing in any given direction, even though it be kept headed in this direction and continuously driven at full speed. This is because in addition to the actual movement through the air there also must be considered the movement of the air itself—a movement that will be of evident effect if the ground is in sight, but which at night or over water can hardly disclose itself even though it may be causing a lateral or angular drift, or even a direct movement backwards, at greater speed than the air speed of the vehicle. At the time this is written the most interesting case in which this effect has been observed occurred in Bleriot's flight across the English Channel, in the course of which, during a very few minutes when the land on both sides was out of sight because of fog, several miles leeway were made in spite of a supposed proper direction of the machine, involving subsequent coasting along the English shore to make a landing at the point for which a supposedly straight course had been steered at the outset (see Figure 265).

FIXED-DIAL COMPASSES

Compasses in which the dial is fixed, with the needle moving over it, are commonly used for surveying because of certain points of convenience that they possess for this purpose. They also are used, though for this purpose they are less suitable, by explorers and others in going over land.

FLOATING DIAL COMPASSES

Compasses in which the dial is fastened to the needle, which is attached with its points in registry,

with the north and south marks on the dial, and the whole so mounted as to turn very lightly—usually by floating in a liquid—constitute the common form of mariner's compass. They have the advantage of pointing not only the north and south, but the other cardinal and intermediate directions in such a way that any given direction can be readily seen at a glance, without revolving the case.

BAROMETERS

A barometer carried on an aerial vehicle serves two purposes, that of indicating altitude and that of forecasting weather changes. In either case the barometer is simply a pressure gage, indicating the atmospheric pressure at any given time.

MERCURIAL BAROMETERS

Perhaps the most reliable type of barometer is that in which the air pressure is balanced against that of a column of mercury, the weight of this liquid being so great that a thirty-inch column of it is sufficient to afford a pressure of 14.7 pounds to the square inch—balancing the entire pressure of the atmosphere on the given area at sea level.

ANEROID BAROMETERS

In aneroid barometers the air pressure is indicated by the action of the pressure against the thin metal sides of one or more flat vacuum chambers, of thin, elastic, metal disks, between which springs are placed to resist the pressure. A simple multiplying device converts the very slight movement

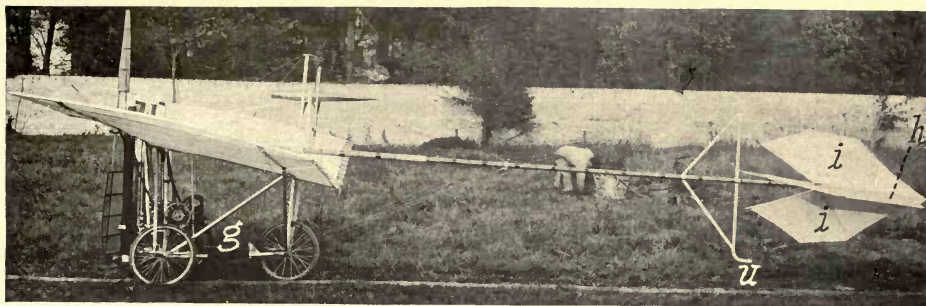

FIGURE 217.—Side View of Santos-Dumont's Belt-Driven Monoplane.

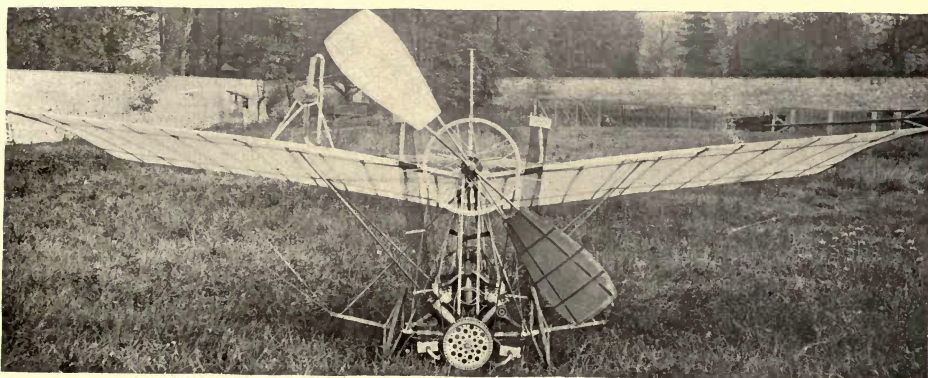

FIGURE 218.—Front View of Santos-Dumont's Belt-Driven Monoplane.



FIGURE 219.—Side View of Santos-Dumont's "Demoiselle."

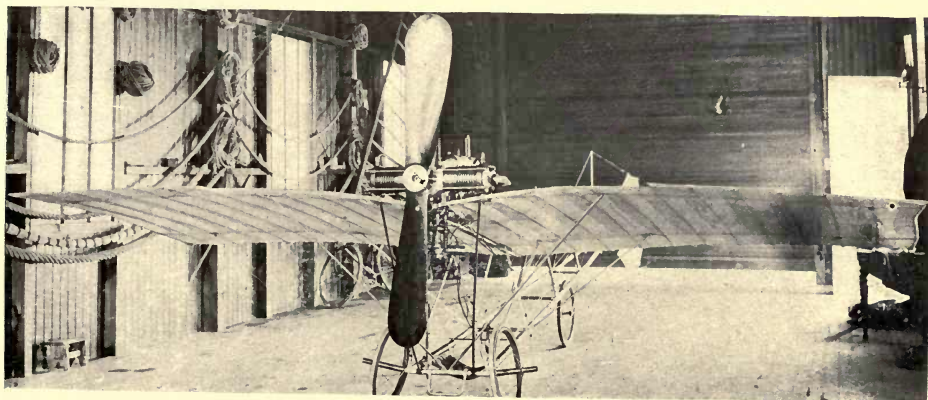

FIGURE 220.—Front View of Santos-Dumont's "Demoiselle." This machine, which weighs less and costs less than many motorcycles, is the smallest machine that has successfully flown.

of the vacuum-cell walls into the more ample movement of a hand around a circular dial.

WIND VANES

The mounting of a small wind vane on an aerial vehicle is useful not in that it can afford any indication of lateral drift of the whole atmosphere, but to the extent that it will show leeway made from a straight course through the effect of unsymmetrical forward resistances such as can arise in the manipulation or adjustment of balancing and steering devices. To be of the highest utility such a wind vane should indicate not only lateral but also vertical deviation, for which reason a ball or gimbal mounting would seem to be the proper thing.

In the Wright brothers' experiments they often use a short strip of tape or cloth, perhaps a half-inch wide and a couple of feet long, tied to some forward part of their biplane so that by the angle of its drifting back towards the operator an indication is had of the performance of the vehicle.

MISCELLANEOUS INSTRUMENTS

In addition to the more important instruments already enumerated there are several others that might conceivably prove useful or requisite.

The use of a level as a sort of grade indicator to show angles of ascent and descent must be of evident utility. Such a level already applied in some aeronautical experiments is that illustrated at Figure 254, in which the body is a light metal cup, covered by a spherically curved glass top and

filled with alcohol except for the small space occupied by the bubble at the top. The series of concentric rings or grooves in the inner side of the glass cover, made visible by filling with black enamel, afford instant indication of longitudinal

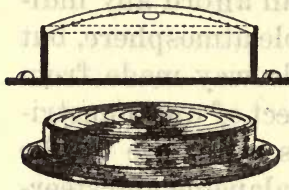

FIGURE 224. — Universal Level. This consists of a metal cup with a curved glass top, beneath which a bubble floats in a liquid. The direction of its movement from the center shows the direction of its tilting, while the amount of its movement over the graduated rings on the glass is a measure of the extent of the tilting.

or lateral deviation from a normal level course by forcing the bubble away from its normal position at the center of the glass to a position away from this point to a distance corresponding with the change in level and in a direction corresponding with the direction of the change.

A quickly manipulable sextant, or some practical or approximate equivalent of this valuable instrument of navigation, seems to be the one evident hope—aside from methods of dead reckoning—for determining and maintaining a course against a lateral drift due to the wind, as suggested on Page 423. The difficulties, however, of making reliable observations of sun or stars from aerial vehicles are likely to prove very great.

The provision of a timepiece of chronometer qualities is an evident necessity if long aerial voyages are ever to be undertaken. As is well understood by all in the least degree familiar with navigation, an accurate chronometer is the modern navigator's chief reliance for determination of his longitude.



FIGURE 245.—Side View of Blériot XI with Wings Tied on Frame.

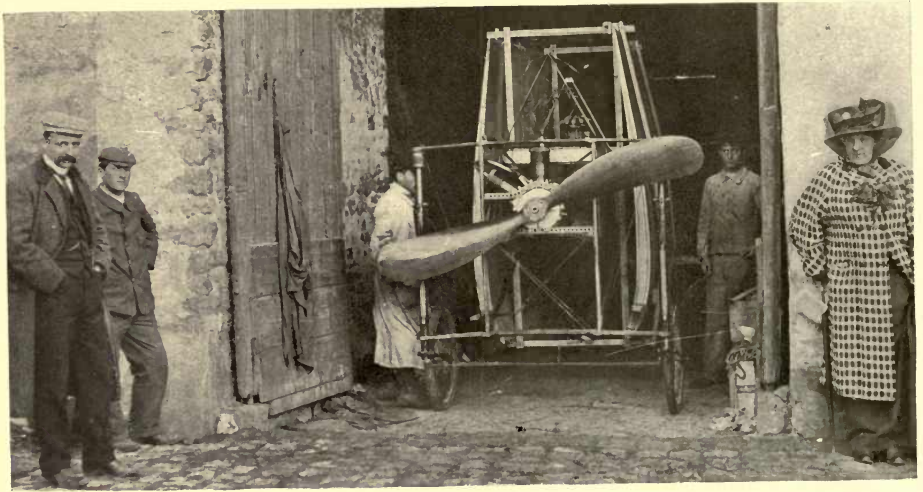

FIGURE 246.—Front View of Blériot XI, Showing Demountable Wings.



FIGURE 247.—Assembling Blériot XI.

CHAPTER FOURTEEN

MISCELLANY

In addition to the more important and more evident considerations that disclose themselves in any survey of the achievements and the prospects of modern aerial navigation, there is discovered a great number of more obscure possibilities—possibilities at the present time impossible to appraise and even difficult to define, but nevertheless constituting proper subjects for some measure of attention.

In this connection it is perhaps well for the reader to impress upon himself the idea that the aeroplanes of today, despite their decidedly remarkable recent successes, must probably bear to the more nearly perfected mechanism of the flying vehicle of the not distant future some such relation as was sustained by the automobile of ten or fifteen years ago to the wonderful, practical, popular, economical, and in every essential respect successful vehicles that today throng the streets and roads of all civilization, and around the construction and improvement of which there has developed a science that in itself constitutes a special department of engineering and an industry in which are invested hundreds of millions of dollars. It may seem to the casual reader a venturesome

thing to predict any similarly extensive development of aerial vehicles. Yet it is to be remembered that even the most accustomed forms of modern transportation—the railway, the steam vessel, the bicycle, the automobile, etc., all had their very inception actually or almost within the lifetimes of people now living, while without exception their development from the experimental stage to the status of unquestioned utility has covered much shorter periods.

Certainly it cannot be escaped or overlooked that the atmosphere as a medium of travel affords more room with less limitations than apply to any other mode of transportation; that it is the medium used by birds for the transportation of considerable weights at great speeds with absurdly small power; and that, though the bird possesses the almost inimitable coördination of animal mechanism, man has nevertheless proved already capable of imitating this coördination and control not only in a considerable degree, but also with remarkable success and safety—the lives so far lost in this growing conquest of the air with heavier-than-air machines being much smaller for given distances traveled than proved the case in the development of apparently much safer means of terrestrial and aquatic travel.

APPLICATIONS

Concerning the possible and probable applications of aerial vehicles, it is perhaps easier to argue than it is to convince, but at least it will be admit-

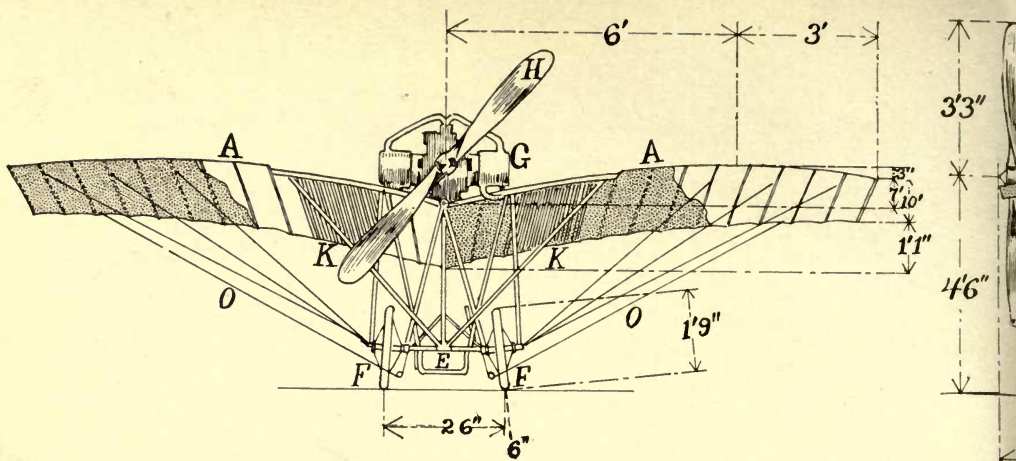
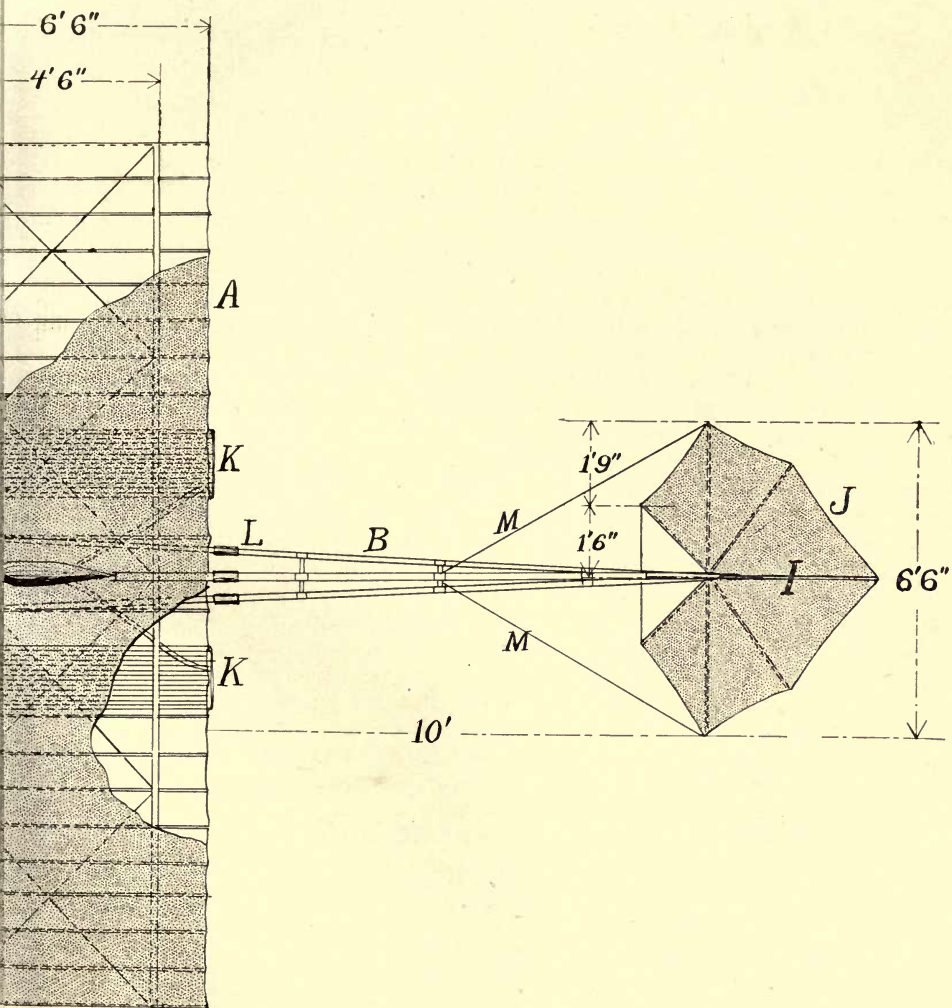
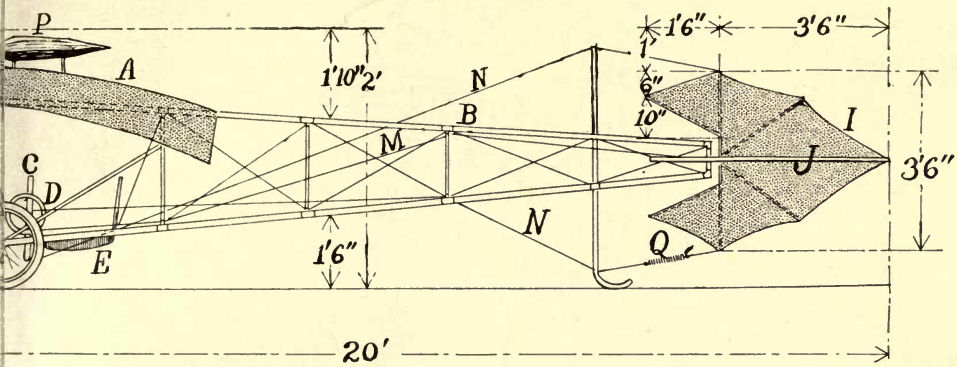
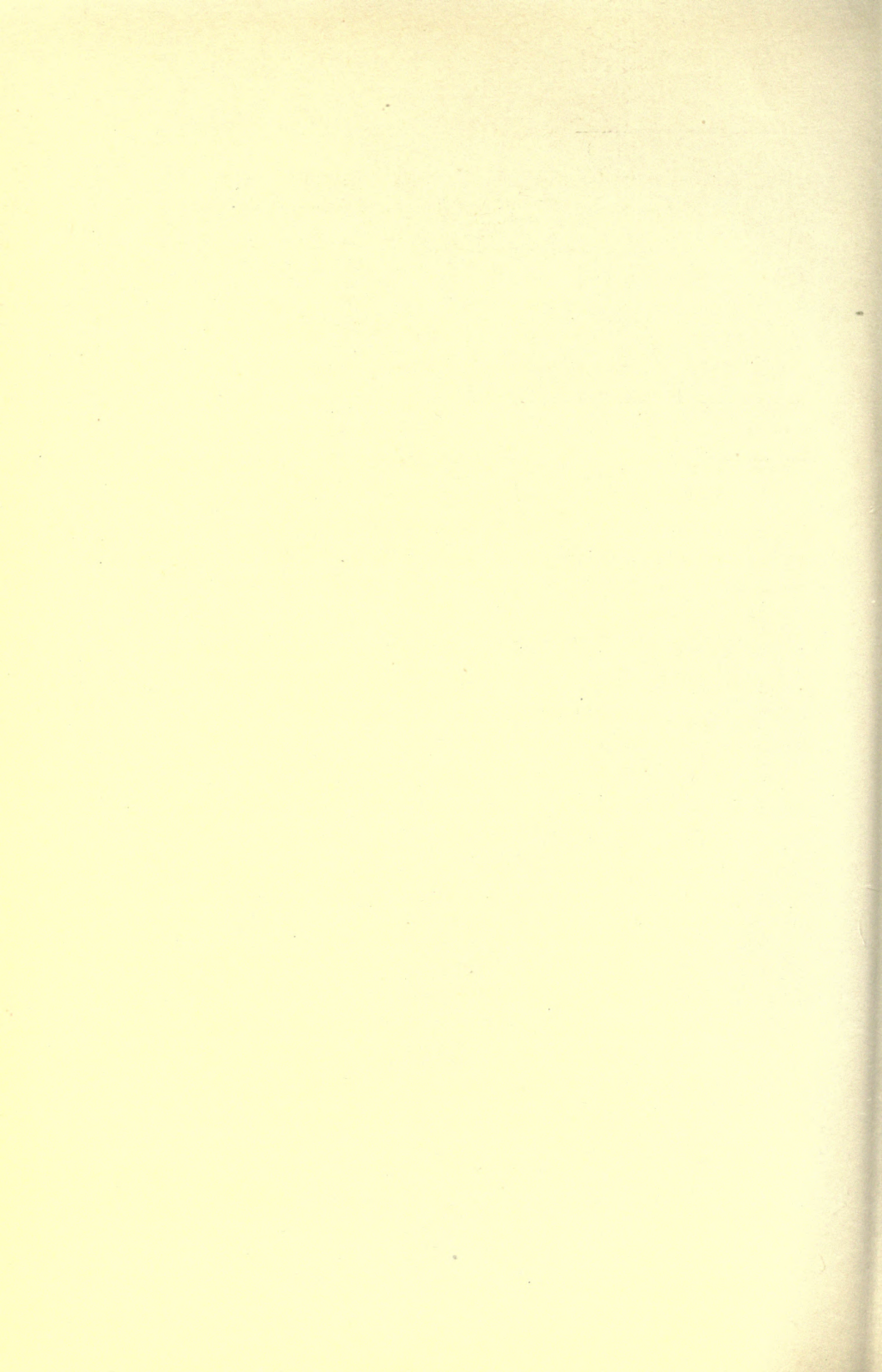

FIGURE 221.—Scale Drawings of Santos-Dumont Monoplane. This is the lightest, least expensive, and one of the most successful power-driven aeroplanes yet developed. The main frame *B* consists of three bamboo spars, widely spread in front and brought closely together at the rear. One of these spars is above and the other two below, side by side. All three of these spars are cut at *L*, so that the machine can be readily taken apart and reassembled by use of the tubular sleeves placed at this point. Closely applied wrappings of wire or cord counteract the tendency of the bamboo to split. The monoplane sustaining wing *A* is single surfaced, with the wing bars on the rarefaction side of the ribs, and there is no attempt to round the wing tips or flatten the curves of the end sections. The lateral balance is maintained by wing warping, by the wires *O O*, which pass over the small pulleys shown and then connect directly to a laterally-movable vertical lever. This lever is ingeniously operated by a section of tubing sewn into the back of the operator's coat and slipped over the lever when he is in the canvas seat *E*, so that the natural swing of his body maintains the equilibrium. Fore-and-aft balance is secured by movement of the horizontal rudder surface *J* through the control wires *N N* and the lever *C*, the spring *Q* serving to maintain the wires taut in all positions. Lateral steering is by the vertical rudder *I*, operated by the wires *M M* from the wheel *D*. Several machines of substantially this same type have been successfully flown with different engines, both air and water cooled, but all of somewhat similar two-cylinder, horizontal-opposed types. The most satisfactory results have been secured with the Darraq motor pictured in Figure 116. This engine weighs only 66 pounds, though it develops 35 horsepower, and is water cooled by the radiators *K K*, which consist simply of a large number of parallel tubes arranged under the wing surfaces. The gasoline tank is at *P*. The wooden propeller *H*. 6½ feet in diameter, is mounted directly on the engine shaft, a portion of the advancing edge of the sustaining surface *A* being cut away to accommodate it. The alighting gear consists simply of the two bicycle wheels *F F*, slanted inwards at the top as shown in the front view, and supplemented by the tubular metal skid in front of the rear rudders. The weight of this machine is about 240 pounds. Dimensions are given in feet and inches. For further details of the Santos-Dumont machines, of the particular model above described as well as the various constructions from which it developed, reference should be had to Figures 116, 141, 217, 218, 219, 220, and 238.





ted that such vehicles must find some fields of usefulness, whether or not it is to be contended that these fields will prove exceedingly broad or exceptionally limited.

WARFARE

War being fundamentally an affair of danger and disaster, all possible strictures that can be leveled against the safety of aerial vehicles must lose force when confronted with this application. Much discussion and speculation has been aroused by the contemplation of the possibilities of the flying machine in war—even books having been written in which it has been attempted to portray, often in the most interesting manner, phases of the warfare of the future.*

The schemes that have been suggested in the way of tactics and methods to be employed in aerial warfare cover the widest possible range, from the ridiculous to the plausible.

A somewhat discussed aspect of the flying machine's war possibilities has been that of mounting on dirigibles and other aerial craft firearms of types similar to those of the smaller calibers used in land and naval warfare. Because of the great weight of even the lightest of effective modern weapons, the considerable weights of ammunition required, and the comparatively low accuracy in firing at moving targets from unstable platforms, it is impossible to believe that any real success can attend such plans. Even under the most favorable

*In this connection, the writer has particularly in mind H. G. Wells' "War in the Air."

circumstances, it is one of the well-established statistics of military history that for every man killed as much as or more than his weight in metal must be shot from firearms. It therefore seems scarcely clear how aerial vehicles, necessarily rather limited in their carrying capacities—even though great further progress in this regard be made—can effect very material damage upon the unconcentrated troops that commonsense modern tactics have already dictated as a means of minimizing danger from attacks with machine guns and shrapnel. Elimination of this sort of aerial warfare from consideration leaves the aerial vehicle with only one, but a sufficiently dangerous method of attack—by the dropping of high explosives as accurately as may prove possible into the weakest and most vulnerable points in the enemy's military and social organization. And this method, as speculation upon it is indulged in, becomes sufficiently horrifying to appall the most skeptical tactician or hardened soldier.

Undoubtedly, the initial points of attack would be on the sea the enormously costly mechanisms—the battleships, cruisers, and torpedo-boats—of modern navies, which even today seem open to destruction should occasion arise by very ordinary application of the capabilities of such aeroplanes as have been already developed—working, it is to be emphasized, not individually but in fleets, with results that seem quite inescapable. On land the points of attack might be the storehouses of military and food supplies, or even the property in



FIGURE 222.—Side View of the R. E. P. Monoplane.



FIGURE 223.—Three-Quarters View of the R. E. P. Monoplane. The wing wheels *b b* and the twisting rudder *h* are features of this machine.

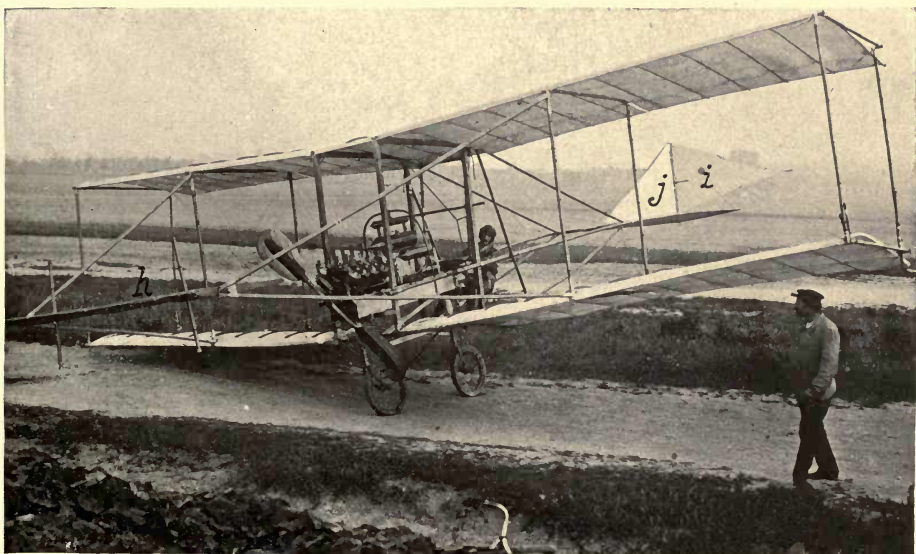

FIGURE 224.—Captain Ferber's Dihedral Biplane.

great cities, which, all action of peace congresses and international tribunals to the contrary, it is very likely that a determined and aggressive foe would ultimately assail after issuing due warnings commanding immediate removal of all non-combatants, such warnings to be disregarded at the peril of the party attacked. For in the last analysis of the bitterness of conflict between militant nations, wars are fought less by rules than to win victories.

In the face of such tremendous improvement in mechanisms for the destruction of life and property—without which war cannot be successfully waged, the view that warfare can continue indefinitely, in a world of civilized and intelligent beings constantly growing more civilized and more intelligent, is an incredible one. Altogether more likely than this indefinite continuation of war, or such voluntary disarmament and arbitration as is proposed by idealists, seems an unavoidable and enforced arbitration, imposed upon all by concerted action of the great powers of the world, which instead of maintaining individual armies whose military equipments—land, naval, and aerial—will be pitted against one another will pool their forces for the maintenance of an international policing force to compel arbitration of international questions, and to punish terribly such benighted nations as may have the hardihood to assert militant dissent from the prescriptions of the intelligent majorities of civilization.

Almost as significant as its power for de-

struction is the invulnerability of the aeroplane. Though without armor or any corresponding protection, yet, operated in fleets, and if necessary under cover of night, no one familiar with modern gunnery or the use of firearms needs to be told how utterly difficult and impracticable will be found all schemes for winging the aerial vehicles. It is difficult enough to hit a fixed target from a substantially-mounted weapon after the range has been accurately found. It is more difficult to strike a moving target on the ground, or afloat on the water, though even in these cases the restriction of the movement to a horizontal plane and the possibility of correcting errors in the determination of the range by noting the splash in the water, or dust thrown up, is a great help. But to strike a vehicle moving through the air, capable of extraordinary celerity in maneuvering, capable of three-dimensional travel—up and down as well as in all lateral directions—and with no means whatever of finding range, can never happen except by the purest of pure accidents. And when it does happen its effect upon the enemy's strength is so certain to be so utterly trivial—involving the destruction of no more than a few hundred dollars' worth of machinery and the lives of not more than one or two individuals—that its futility as a means of winning a victory is almost too evident to require discussion.

SPORT

Under the heading of this much abused term can be perhaps fairly characterized the utilization

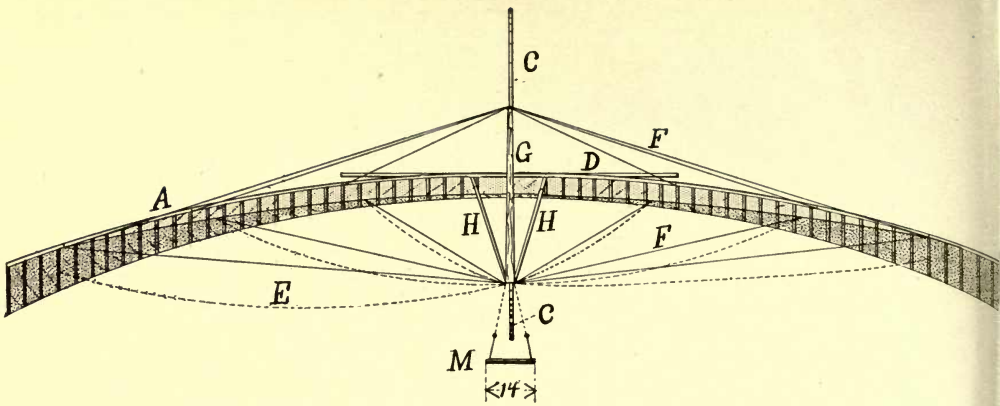
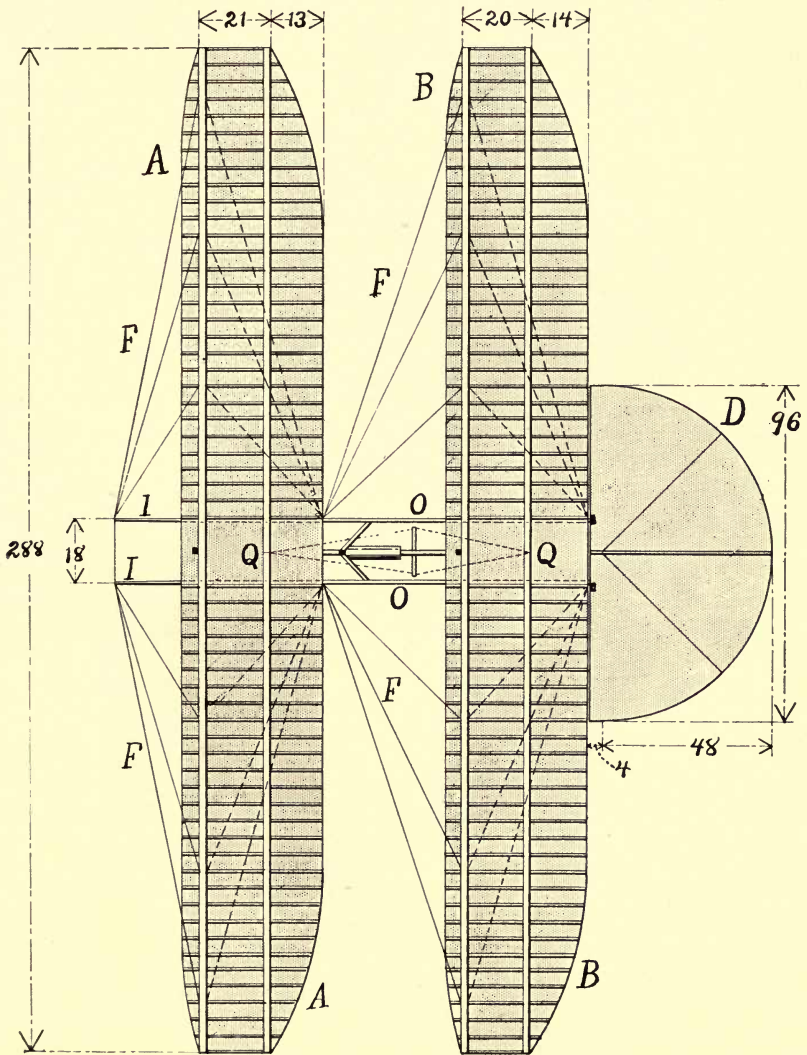
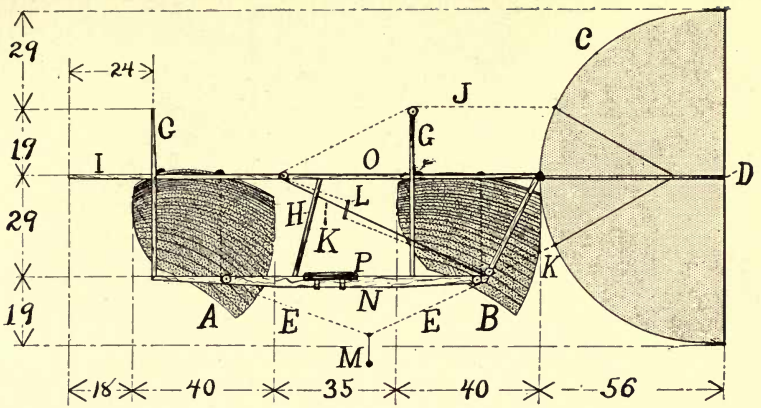

FIGURE 225.—Scale Drawings of Montgomery Glider. This machine is exceedingly simple though as in the case of all aeronautical apparatus only the most substantial and well-considered detail construction is to be tolerated if safety is to be assured. The framework consists primarily of the two light upper bars *OO*, terminating in the spars *II*, and of the heavier bottom bar connected by the four slanting vertical members *HH*. Each of the two main wing frames consists of two wing bars attached on top of *OO*, and bearing on their under sides 58 equally-spaced curved ribs that pass through pockets sewed into the single surface of light rubberized silk percale that is considered the preferable material for the wing covering. The front bar of each wing is firmly lashed to *OO*, rigidly trussed into a pronounced arch by the wires *FFF*, and braced by the masts *GG*, but the rear bars are divided at *QQ* so that they hinge over *OO* and droop loosely at their ends to a level considerably below that of the front bars. They are, however, prevented from lifting above a certain point by the control cords *EE*, which run over pulleys as shown and are attached to the stirrup bar *M*, by means of which the operator controls the device with his feet. When in the air the droop or arch of the wings is not as pronounced as shown in the drawings, which show the machine at rest. The operator sits astride the seat *P* and steers by pressing on one side or the other of the stirrup bar, the cords from which are so crossed that the pressure with the right foot pulls down the rear edges of the left wing ends, and vice versa. This manipulation may be also used as a balancing control, but equilibrium is maintained chiefly by the automatic effect of the very large fin surface *C*, which though it moves up and down with the rudder *D* has no lateral movement. In addition to the dissimilar twisting or warping of the wing ends by pressing down on one side or the other of the stirrup bar, by pressing down on both ends simultaneously all the rear wing tip edges are drawn down together—a manipulation that sets a very effective braking action, by which the machine can be brought to land so lightly that the operator is not even jarred. In addition to these control movements there is another, by pulling down the pulleys over which the cords to the wing *B* are passed, through the action of which the whole angle of the rear wing can be changed in relation to that of the front wing, thus affording control over the longitudinal equilibrium by an elevator-like action of the two wings in relation to each other. The horizontal tail surface *D*, proximate to the center of the rear edge of *B*, is controlled by the cords *JK*, which are attached to the wooden clamp *L*, automatically located by the effect of the angular pull upon it in any position at which it may be placed on the stationary wire *K*, which runs from one of the bars *O* to the bar *N*.

The ribs of this machine should be made of clear, well-seasoned spruce, $\frac{1}{4}$ inch wide and $\frac{5}{16}$ inch deep, and each rib must be made of two pieces glued together under pressure in a form, so that they will hold the requisite curve. The wing bars are best made of hickory, about $1\frac{1}{2}$ inches thick at their centers, and tapered to about half this section at the ends. The frame bars can be of spruce, about $1\frac{1}{4}$ inches by 2 inches at their centers and tapered to their ends—to a smaller size forward than at the rear. *N* is likewise about $1\frac{1}{4}$ inches thick, and may be as deep as $3\frac{1}{2}$ inches at the center. The tail framing is of light wood edges stayed by wires arranged like the spokes in a bicycle wheel. The machine weighs about 40 pounds. All dimensions are in inches.



of aerial vehicles for pleasure travel in one manner and another.

Aeroplane contests already have provided thrills sufficient to satisfy the most *blase* audiences, and in the near future, when the speeds made seem certain to become vastly higher than any that have been maintained with any other types of vehicles, they will become even more spectacular. Moreover the element of safety in such contests is much greater than might be supposed—probably much greater than in automobile racing, which has been responsible for a truly appalling list of fatalities. This is because, while land vehicles are built to travel on land, they are built to do so only on especially prepared courses, so when an automobile leaves the road, or a rail vehicle leaves the rails imminent and terrible dangers are introduced, whereas in the case of the vehicle designed to travel in the air—even a plunge to the earth involves movement *through* rather than away from its natural route, with corresponding chance if the vehicle be well designed of regaining its normal control and of recovering its equilibrium, or, at worst, of landing without injury to the occupant.

MAIL AND EXPRESS

The first commercial applications of flying vehicles must inevitably be to the transport of light commodities, such as it is desirable to convey at great speeds and which can be paid for at high rates per unit of weight.

The ideal service of this character would be

that of a number of vehicles traversing a route of the maximum distance possible to accomplish without alighting, dropping mail bags on clear areas where watchers would be waiting to receive them.

NEWS SERVICE

Besides for the distribution of mail and express, aerial vehicles may lend themselves to the distribution of newspaper matrices and illustrations prepared at central points for quick transmission to rural newspaper plants, not provided as at present with expensive editing and composing forces, but chiefly equipped with stereotyping and printing facilities.

EFFECTS OF LOW COST AND MAINTENANCE

Most important factors in the further improvement and the future applications of aerial vehicles are certain to be the lower first and maintenance costs that are reasonably to be anticipated if what has been already done is any criterion.

With some of the most efficient modern aeroplanes it has been proved possible to transport weights of as great as 1,600 pounds for distances of twelve and fifteen miles on a gallon of gasoline—a result that compares most favorably with even the best secured with modern automobiles, especially at anything like similar speeds—in the neighborhood of 40 or 45 miles an hour.

An inevitable result of low first and maintenance costs must be the extensive acquisition of aerial vehicles by all manner of individuals—indi-

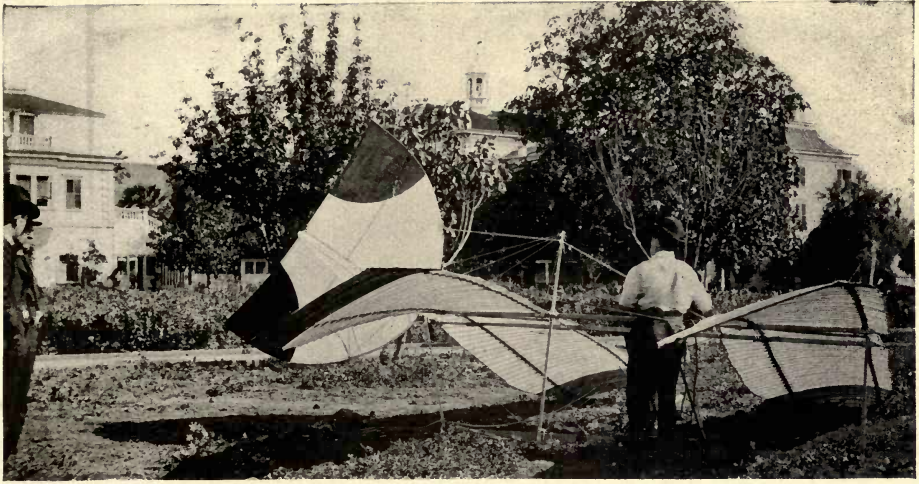

FIGURE 226.—Side View of Montgomery Double Monoplane Glider. This machine was probably built on more scientific principles than any other so far constructed. On at least three occasions operators have deliberately turned side somersaults with it, besides which many descents have been safely made from heights ranging up to 4,000 feet, at speeds said to have ranged as high as 68 miles an hour. Its equilibrium is so positive that it automatically rights itself when released upside down in the air.

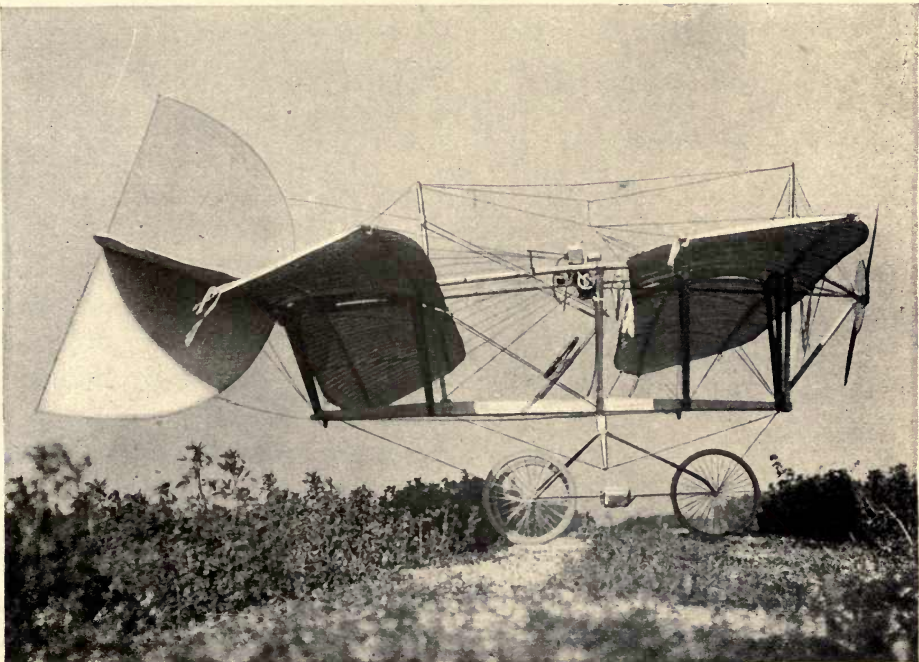

FIGURE 227.—Side View of Small, Power-Propelled Montgomery Double Monoplane. This machine has a wing spread of 26 feet, an area of 250 square feet, and weighs from 400 to 450 pounds, including the weight of the operator and the fuel. It flies at a speed of over 30 miles an hour with less than six horsepower, and employs more deeply cambered curves than have been successfully used in any other machine. Its stability is inherent in the form of its surfaces rather than dependent upon the manipulation of balancing devices, so that if dropped upside down it will invariably right itself and commence gliding with a fall of not over four or five times the span of its wings. The large vertical surface at the rear has no movement sidwise, being a stabilizing fin, not a rudder.

viduals of a class today quite unable to afford even the most inexpensive automobiles. More than this, the aerial vehicles not being confined to roads or highways of any kind, there is not the slightest possibility either of monopolies or of limitations in their use other than the direct physical limitations imposed by such mechanical imperfections as, of course, can never be wholly eradicated, however they may be minimized.

GENERAL EFFECTS

The wide introduction of aerial vehicles into the hands of the general public, if it ever occurs, and it seems more than likely that it will occur, cannot fail to exert consequent influences of the profoundest importance upon innumerable phases and regulations of the accepted social order. The very independence of movement which only an aerial vehicle can possess will in itself unfailingly modify the whole structure of civilization.

A most certain result of the new condition in human affairs following upon man's achievement of flight will be the inevitable effect on laws and customs. Assertions to the contrary notwithstanding, it is impossible to see how either exclusion laws or customs laws (except perhaps in the case of very heavy commodities) are going to be at all enforceable in the coming era of aerial navigation. The boundaries of every nation in the world, except possibly those of the most densely populated, will absolutely cease to exist as barriers that can be policed and safeguarded against pro-

gressing humanity's perfectly natural disposition to travel and communicate without let or hindrance.

A more sinister aspect of this time to come is the tremendous facility with which the aerial vehicle will lend itself to the perpetration of crime with almost perfect assurance for the criminal of escape from punishment and other consequences. Indeed, as a police problem the aeroplane bids fair to become far more serious than the much-apprehended and now-realized noiseless gun. Nevertheless, no one with any real optimism can long believe that progress in science and invention can have any permanent injurious or detrimental effect on human affairs. Perhaps the solution will be a greater effort on the part of society as a whole, and especially upon the part of the now more powerful and arrogant elements within it, so to ameliorate and improve the conditions of the "criminal classes", so-called, and more particularly of the poverty-stricken classes—from which nearly all criminals are recruited by the reactions of oppressive environments—that less crimes will be committed not because of policing and punishment, but because of reduced incentive.

RADII OF ACTION

Since almost the only limitation at the present time in the way of indefinitely-continued flight, even with present machines—and barring, of course, the matter of more or less violent storms—is the difficulty of carrying sufficient supplies of

FIGURE 229.—Side View of Latest Curtiss Biplane. This machine, which won the world's speed record at Rheims, France, in August, 1909, is one of the lightest machines ever built, weighing less than 500 pounds. Its lateral balance is maintained by the ailerons at a , and its longitudinal balance by the elevator surfaces b b b . The wheeled running gear g g is without springs. Note the forked aileron control embracing the operator's shoulders. Propulsion is by a single propeller at the rear, revolved by an eight-cylinder, V-shaped, 50-horsepower motor.

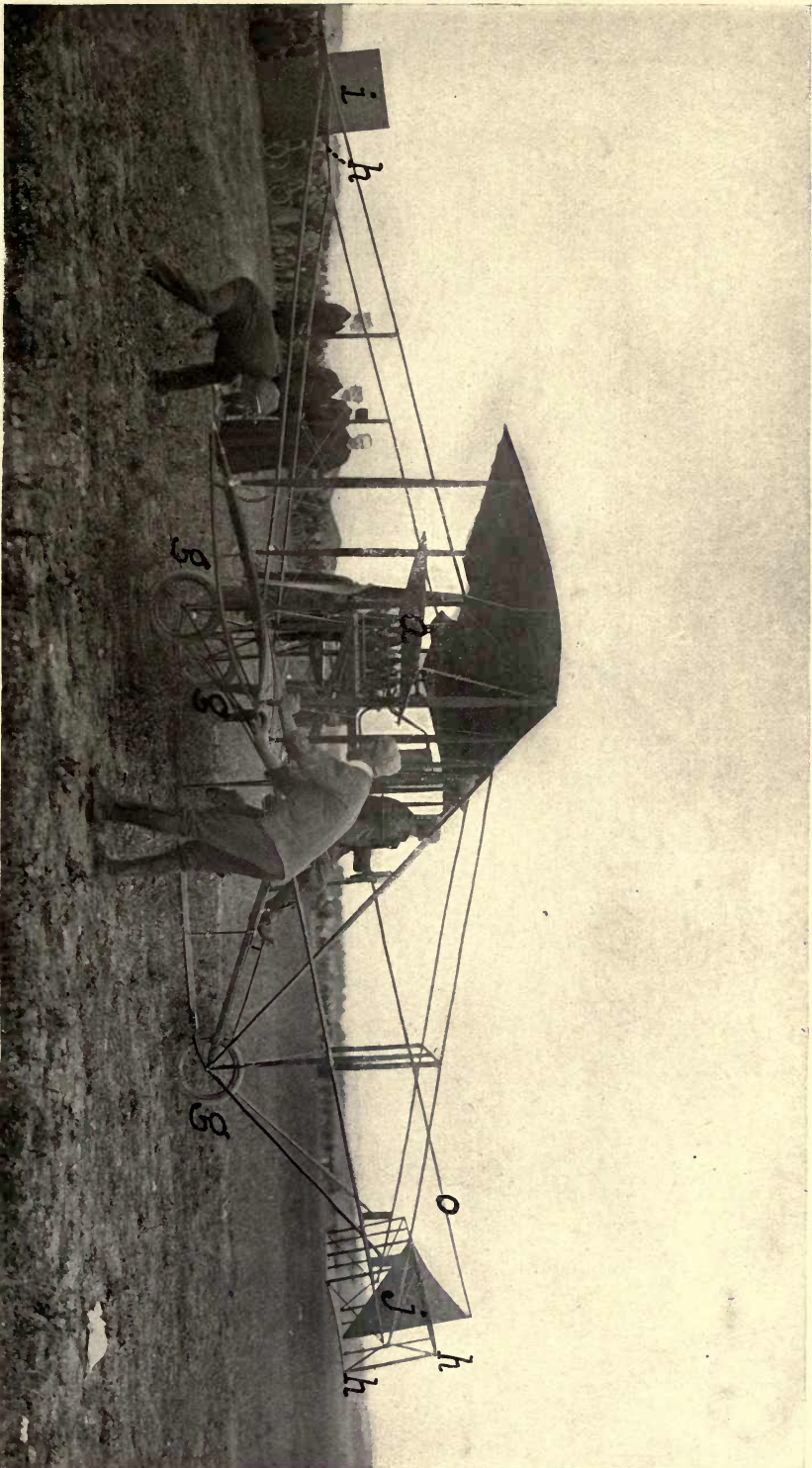

fuel, it is clear that as more efficient propellers and engines, or surfaces affording given sustentation with smaller head resistances, may be developed, the radii of action is certain to be increased in proportion.

INFLUENCE OF WIND

In the case of water travel, excepting in rare instances of river navigation through rapids or of navigation through narrow channels with rapid tidal flows, the currents in navigable waters are not of sufficient speed materially to help or hinder vessels passing through them. With the atmosphere the case is quite the other way. In this lightest of earth's traversable media movements of the air in the form of wind, of velocities considerably in excess of the best speeds that have been attained with aeroplanes, are common. In fact, it is a fair assertion that winds of even as high as 100 miles an hour—approximately twice as fast as the greatest present aeroplane speeds—are occasionally to be reckoned with, even though they will not be commonly encountered and never will be flown in when such flight is avoidable.

DEMOUNTABILITY

Apparently not satisfied with the altogether sufficient difficulties of making flying machines to fly, more than one inventor has in addition attempted to construct such vehicles in folding form—probably inspired by the beautiful perfection of the bird's wing mechanism—with the idea of simi-

larly quickly stowing the wings and other parts of the machine in compact and portable shape.

It being a condition involved in almost any conceivable aerial vehicle that considerable dimensions must be employed because of the necessity for operating in one way or another upon large areas of air, there is much to be said in favor of any scheme that seems to promise a compacter arrangement of the vehicle elements when the machine is at rest than is required when it is in the air. This is important both for storage and for shipment and, as has been suggested, has its counterpart in all known flying creatures, which without exception fly with surfaces capable of being folded more or less out of the way when not in use.

But the difficulties in the way of making reliable folding wings are very great—so great that in the present state of the art it seems hardly desirable to attempt overcoming them until after more perfect and dependable results are secured in the more vital functioning of flying mechanisms.

Demountability, however, is an altogether different thing from folding, this term implying only the ready detachability and separation of different parts with corresponding facility in reassembling. Several very successful modern aeroplanes are made demountable in greater or lesser degree.

A further advantage of demountability is the conversion by its means of the aerial vehicle into a more or less capable road vehicle. Thus the "June Bug" of the Aerial Experiment Association,

with its wings off, was still capable of rolling along on its wheeled starting gear. In this condition it proved capable of speeds as high as forty-five miles an hour, simply run on the road under the thrust of its own propeller.

In the case of the "June Bug", however, the wings when taken off were not carried with the machine, making the scheme employed in the most recent Bleriot monoplanes and illustrated in Figures 245, 246, and 247, altogether superior. As is shown in these illustrations, the two main wings are simply detached from their proper places on the *fuselage* and tied compactly against the sides, so that the machine, carrying all of its flying elements, makes an excellent vehicle for running on good roads—a most desirable feature in case a landing is made on a bad surface and it becomes necessary to prospect about before a suitable place for starting is found.

Undoubtedly this matter of demountability, especially as machines become more practical and more numerous, is one that will merit further consideration by designers, with the result that present-day shortcomings will decreasingly handicap future progress.

PASSENGER ACCOMMODATION

Accommodation for passengers in most of the flying machines so far built has been of a more or less makeshift character, it being appreciated that the most essential thing as yet is to produce machines that will fly, leaving the minor question of

comfortable passenger accommodations for subsequent solution.

SEATS

About the least that can be provided in the way of passenger accommodation is some sort of seating arrangement. So far the most of such seats have been of the most elementary construction, as is suggested in the illustrations throughout these pages. Lately, however, some of the more advanced craft are appearing with very comfortable arrangements for seating the operator, as is particularly evidenced in the boat-like cockpits provided in the Bleriot, Antoinette, and R. E. P. machines, as shown in Figures 249, 250, and 252, respectively.

HOUSING

As proved the case in the development of the automobile, it probably will be only a short step from the provision of comfortable seats to the provision of enclosures for these seats, housing the operator and passengers from the weather and from the wind of the movement through the air.

UPHOLSTERY

Cushioning of the bottoms and backs of seats is a luxury that has already found application to the aeroplane, though cane and wooden chair seats are found rather lighter.

Pneumatic Cushions, of covering materials with rubber or other gasproof linings, inflated with air, are much used in boats and yachts and to some extent for the seats of automobiles. Pneumatic



FIGURE 248.—Wicker Chair and Foot Control of Ailerons in Sommer's Farman Biplane.



FIGURE 249.—Cockpit of Bleriot Monoplane Number XI.

cushions are exceedingly light, constitute very satisfactory life preservers in case of descent into water, and are sufficiently durable to make them thoroughly practical. It therefore seems reasonable to regard them as an ideal type of aerial-vehicle upholstery.

HEATING

While it can be considered hardly reasonable, in the present status of aeronautical engineering, to transport special devices for keeping the passengers warm as is done in rail and water vehicles and even in automobiles, there is another road to the provision of such comforts without materially adding to the weight or complication.

By the Exhaust gases which must be

emitted from all internal-combustion engines, which are very hot, and which must be disposed of, it is possible to secure a considerable heating effect in a very simple and practical way.

A typical exhaust heater such as is to some extent used for automobiles is illustrated in Figure 255, in which the principle is simply that of a muffler-like apparatus beneath the passengers' feet, and through which the gases from the engine are caused to follow the intricate course indicated by the arrows and determined by the numerous

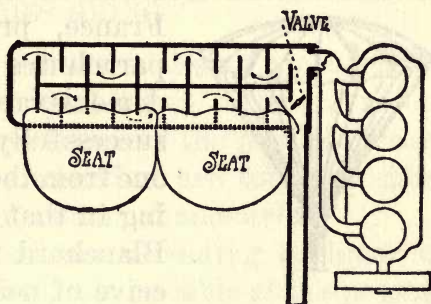

FIGURE 255.—Suggested Use of Exhaust Gases to Heat Foot Warmer.

baffle plates, finally making their exit to the rear. The valve provides means of throwing the heater in and out of action.

PARACHUTES

The use of parachutes antedates the invention of the balloon, it being on record in Loubere's "History of Siam" that 250 years ago an oriental inventor entertained Siamese royalty by leaps from great heights with two parachutes attached to a belt. In 1783 M. le Normand, of Lyons,

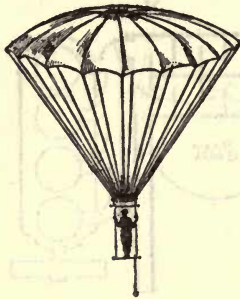

FIGURE 256.—Parachute.

France, proposed the use of parachutes as fire escapes, and demonstrated their utility by successfully descending with one from the top of a high building in that city. The aeronaut Blanchard was the first to conceive of using the parachute in ballooning, and in 1783 he tested one by attaching it to a basket

in which was placed a dog, whereupon the whole being released at a considerable height settled to the ground in safety. In 1793 he descended himself from a balloon, but, though the fall was fairly retarded, he nevertheless suffered a broken leg as a result of his daring. On October 22, 1797, the first really successful parachute jump was made by André Jaques Garnerin from a balloon a mile and a quarter high over the plain of Monceau, near Paris.

Modern parachutes, such as that illustrated in

Figure 256, are made from twenty to thirty feet in diameter, with a hole at the center to prevent oscillation, and without framing of any kind, the series of cords by which the surface is attached to the weight serving to preserve the umbrella-like form essential to a safe descent, and produced primarily by the air pressure. They sustain about half a pound to the square foot. Parachutes capable of safely carrying a man have been made of less than twenty pounds in weight.

DESIGNING

In the design of aerial vehicles an exact science is becoming rapidly established, with its recognized engineering practises and the possible freakish departures therefrom that are found to exist in all departments of technical endeavor.

For the benefit of the intending designer or experimenter, however, it is possible at the present time only to emphasize the important point that this field of engineering is one in which nothing less than a broad and practical engineering knowledge can suffice to produce results. Were successful aerial vehicles to have been produced by the rule-and-thumb methods that have been more or less advantageously employed in most other fields of mechanical engineering, successful flying or at least gliding machines would have been invented two thousand years ago, for failure in the past has been due not to lack of effort or facilities, out to the inadequate technical equipment possessed by experimenters. The conclusion is that the ordi-

nary amateur will do best by closely copying proved constructions.

TESTING AND LEARNING

In testing new flying machines, and even in learning to operate ones of established qualities, there are a number of things to be considered that are a little different from the conditions surrounding the tests of other mechanisms and the operation of other vehicles.

Thus failure of an experiment with a mechanism of this type is likely to be not a mere mechanical failure, but also may readily result in injury to or the death of its operator unless ingenious and well-considered precautions are taken to assure a maximum prospect of safety.

Likewise, for a beginner to attempt to drive a machine even of a type known to be well capable of flying, the attempt can easily become most dangerous business if gone at in a reckless manner.

LEARNING FROM TEACHER

By all means the best method of learning to operate a flying machine is that possible when the machine can carry two people and the pupil can thus take his first rides with an expert.

PRACTISE CLOSE TO THE SURFACE

When an instructor is not to be had, as in the case of a new machine that no one knows how to fly—not even that it will fly—or of a machine that will carry only one person, it becomes possible for the operator to acquire the necessary dexterity

only by practise. Such practise is most readily and speedily secured by the use of large level areas over which the machine can be run on its wheeled or other running gear, with "low jumps" into the air that extend to greater and greater lengths as the experimenter becomes proficient.

Practise over Water presents a number of very great advantages over any other sort of practise that can be had, there being in the first place the level and almost ideally smooth surface, in addition to which, if it comes to falling, water is better to fall upon than hard ground. Drowning is sufficiently guarded against by the circumstance that almost all modern machines have sufficient wood in their construction to float them, besides which they can be fitted with inflated fabric floats and the operator provided with a life preserver.

MAINTAINING HEADWAY

If there is any one point in the operation of most modern aeroplanes that calls for especial emphasis, it is the most imperative necessity for always maintaining headway, since the forward movement through the air is all that sustains the machine in the air.

LANDING

Just at the moment of landing, it is possible with most machines to execute an abrupt upward steering movement, with the effect that the wing surfaces strike the air at a very steep angle of incidence, causing them to act as a sort of brake. This maneuver will be better appreciated if its relation

is realized to the similar maneuver of birds, which always at the moment of alighting oppose the full areas of their wings to the direction of travel.

AERIAL NAVIGATION

Though in its general meaning this is the subject to which the whole of this book relates, in a more specific sense it is to be applied to the details of operating and driving aerial vehicles.

Considered from this standpoint aerial navigation, like water navigation, presents its special and peculiar problems.

This being the situation there can as yet be no established science of aerial navigation, but it is nevertheless possible to formulate some of the essential principles of such a science and to perceive many of the factors in the problem.

FLYING HIGH

Flying very high so far does not seem to have met with the approval of any but the more reckless experimenters, and in no case recorded at this writing has any power-driven aeroplane ascended more than 4,600 feet high, while ascents even to this and to other considerable altitudes have been made not so much from any necessity for flying great heights, as under the more frequent spur of prize competitions. The longest sustained flight made previous to this writing, that of Farman at Rheims, on August 27, 1909, was at a height rarely exceeding ten feet from the ground.

Steadier Air than is in most cases to be found

nearer the ground is well established to exist at greater heights, particularly over surfaces that are irregular or built-up.

Choice of Landing, in case of motor breakdown or other reason for descent, is greatly broadened by flight at considerable altitudes. This will be

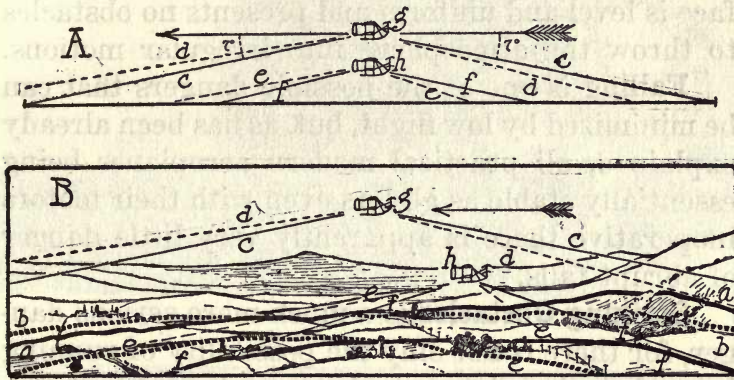

FIGURE 257.—Effect of Height Upon Choice of Landing. Note that the machine *g* has a much greater area than the machine *h*, down to which it can glide in case of motor failure, its angle of descent being indicated by the solid lines *c c*, those at *f f* being for the machine *h*. The dotted lines *d d* and *e e* show the distortion from the circle upon which landing is possible, when there is wind blowing in the direction of the arrow.

more readily understood from reference to *A* and *B*, Figure 257, in which the aeroplanes *g* and *h* can normally descend in calm air on gliding angles represented by the solid lines *c* and *f*, thus affording choice of landing anywhere within a circle of a diameter proportionate to the height of the start and the flatness of the angle of descent.

FLYING LOW

Flying low, while introducing safeguards also introduces dangers, especially if attempts be made to fly low over rough country, in which the chance

of striking obstacles with the machine flying reliably might easily become more serious than the danger of a fall from the remoter possibility of some desperate and unexpected breakdown.

In all probability the lowest regular flying of the future will be over water areas, where the surface is level and uniform and presents no obstacles to throw the atmosphere into irregular motions.

Falling is one of the possible dangers that can be minimized by low flight, but, as has been already explained, all practical modern aeroplanes being essentially stable as gliders even with their motors inoperative there is apparently very little danger of abrupt falls.

Striking Obstacles is a much more serious danger, for there is not only the possibility of running into obstacles not seen in time because of the attempt to skim over them too closely; there is also the danger while flying low of being thrust enough out of the intended course by a sudden wind gust to cause such an accident.

Vortices and Currents in the air are well demonstrated to exist in proximity to all terrestrial objects during winds, and are of a violence and complexity of motion varying with the strength of the wind and the character of the obstacles. Travel through such vortices and currents obviously is much more dangerous than travel through uniform air, a fact that has already been discovered by some of the pioneers in aerial navigation. An interesting example was remarked by Glenn Curtiss at Rheims, in 1909, when over one



FIGURE 250.—Seating Arrangement and Control System of Antoinette Monoplane.



FIGURE 251.—Sling Seat of Captain Ferber's Biplane.

part of the course he found the air to be "literally boiling", as he expressed it.

TERRESTRIAL ADJUNCTS

In the impending utilization of the air as a highway for sporting and military operations and probably for the conveyance of mail and express matter, if not absolutely as a medium for all kinds of passenger and commercial traffic, it is inevitable that systems of signalling from the earth's surface to the aerial vehicles must be devised.

An ideal means would be the use of wireless telegraphy but this in its present development comes nearer to permitting the aerial craft to receive messages than to send them, because of the much greater weights of sending apparatus.

SIGNALS

The kinds of information that it is likely to be most essential for the future aerial pilot to have from terrestrial stations will be data in regard to his location, measurements of wind direction and velocity, weather forecasts, etc. To these ends it doubtless will prove feasible to establish lettered or other landmarks easily recognized by day, with systems of lights to serve the same purpose by night. The idea of painting signals, and even the flying machines themselves, with luminous paints capable of emitting a clearly-visible glow in the dark has been suggested, and doubtless could be developed into a considerable safeguard against accident and a means of greatly facilitating navi-

gation. The most recent and interesting work along this line has been done by William J. Hammer, of New York, the well known physicist, who is secretary of the Aeronautic Society.

Fog Horns and Whistles would provide a means of signalling weather and wind conditions, of transmitting orders, etc., at times when view of the earth's surface might be obscured by low-lying fogs or clouds.

The United States Weather Bureau system of

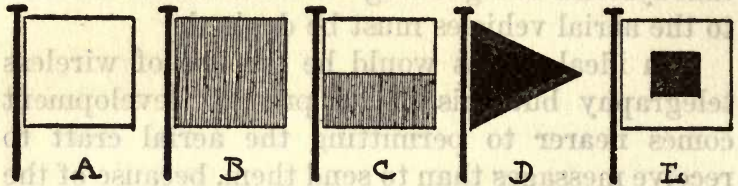

FIGURE 258.—United States Weather Signals. A denotes fair weather; B, general rain or snow; C, local rain or snow; and D, a rise or fall in temperature, according to whether it is placed above or below the other flag displayed. E indicates approach of a cold wave.

weather forecasting by means of simple flag combinations could be readily adapted for display on horizontal surfaces, or even by lights at night.

For use in rainy or foggy weather, along sea coasts, etc., the United States Weather Bureau at present announces its forecasts by means of whistle blasts, one long blast repeated at intervals meaning fair weather; two long blasts indicating general rain or snow, three long blasts indicating local rain or snow, one short blast indicating lower temperature, two short blasts indicating higher temperature, and three short blasts indicating a cold wave. The long blasts are of from four to six seconds and the short from one to three.

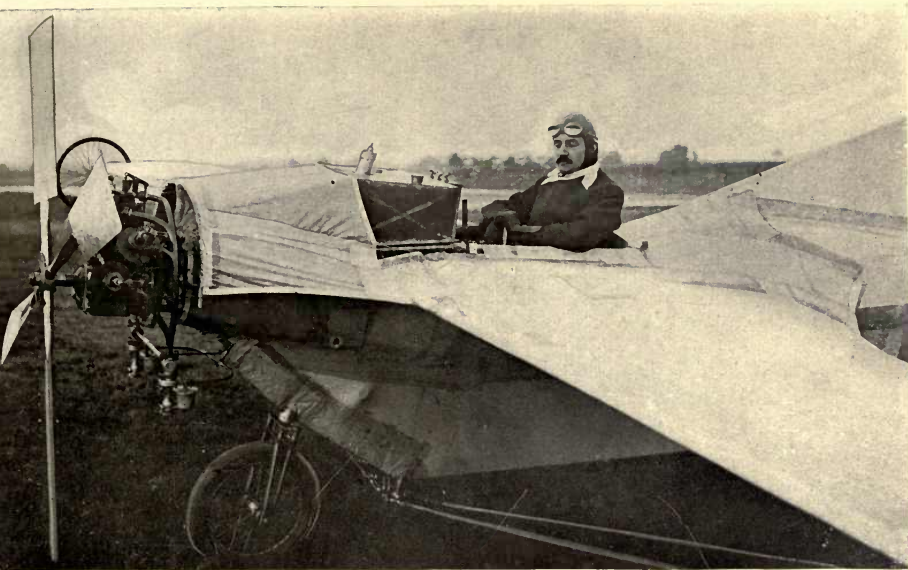

FIGURE 252.—Cockpit and General Details of R. E. P. Monoplane.

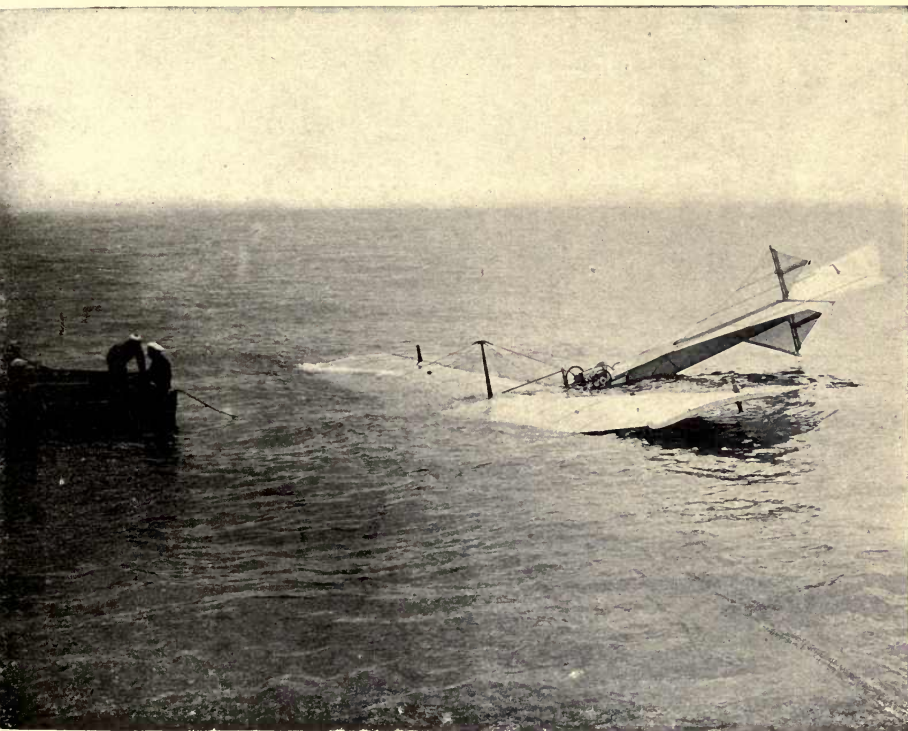

FIGURE 253.—Latham's Antoinette Monoplane in the English Channel. Showing that such a machine may be made to constitute an excellent raft.

PATENTS

The aeronautical patent situation in the United States is a very interesting one—so interesting that the full drawings, specifications, and claims of what seem the two most important, No. 821,393, to Orville and Wilbur Wright, and No. 831,173, to John J. Montgomery, are here reproduced in full.

Other United States patents the claims of which are reprinted herein are numbers 582,718, to Chanute, 582,757, to Mouillard, and 544,816, to Lilienthal.

Specification and Claims of Wright Patent.

No. 821,393.

Filed March 23, 1903.

Issued May 22, 1906.

Expires May 22, 1923.

To all whom it may concern:

Be it known that we, Orville Wright and Wilbur Wright, citizens of the United States, residing in the city of Dayton, county of Montgomery, and State of Ohio, have invented certain new and useful Improvements in Flying-Machines, of which the following is a specification.

Our invention relates to that class of flying-machines in which the weight is sustained by the reactions resulting when one or more aeroplanes are moved through the air edgewise at a small angle of incidence, either by the application of mechanical power or by the utilization of the force of gravity.

The objects of our invention are to provide means for maintaining or restoring the equilibrium or lateral balance of the apparatus, to provide means for guiding the machine both vertically and horizontally, and to provide a structure combining lightness, strength, convenience of construction and certain other advantages which will hereinafter appear.

To these ends our invention consists in certain novel features, which we will now proceed to describe and will then particularly point out in the claims.

In the accompanying drawings, Figure 1 is a perspective view of an apparatus embodying our invention in one form. Fig. 2 is a plan view of the same, partly in horizontal section and partly broken away. Fig. 3 is a side elevation, and Figs. 4 and 5 are detail views, of one form of flexible joint for connecting the upright standards with the aeroplanes.

In flying-machines of the character to which this invention relates the apparatus is supported in the air by reason of the contact between the air and the under surface of one or more aeroplanes, the contact-surface being presented at a small angle of incidence to the air. The relative movements of the air and aeroplane may be derived from the motion of the air in the form of wind blowing in the direction opposite to that in which the apparatus is traveling or by a combined downward and forward movement of the machine, as in starting from an elevated position or by combination of these two things, and in either case the operation is that of a soaring-machine, while power applied to the machine to propel it positively forward will cause the air to support the machine in a simi-

lar manner. In either case owing to the varying conditions to be met there are numerous disturbing forces which tend to shift the machine from the position which it should occupy to obtain the desired results. It is the chief object of our invention to provide means for remedying this difficulty, and we will now proceed to describe the construction by means of which these results are accomplished.

In the accompanying drawings we have shown an apparatus embodying our invention in one form. In this illustrative embodiment the machine is shown as comprising two parallel superposed aeroplanes 1 and 2, and this construction we prefer, although our invention may be embodied in a structure having a single aeroplane. Each aeroplane is of considerably greater width from side to side than from front to rear. The four corners of the upper aeroplane are indicated by the reference-letters a, b, c, and d, while the corresponding corners of the lower aeroplane 2 are indicated by the reference-letters e, f, g, and h. The marginal lines a b and e f indicate the front edges of the aeroplanes, the lateral margins of the upper aeroplane are indicated, respectively, by the lines a d and b c, the lateral margins of the lower aeroplane are indicated, respectively, by the lines e h and f g, while the rear margins of the upper and lower aeroplanes are indicated, respectively, by the lines c d and g h.

Before proceeding to a description of the fundamental theory of operation of the structure we will first describe the preferred mode of constructing the aeroplanes and those portions of the structure which serve to connect the two aeroplanes.

Each aeroplane is formed by stretching cloth or other suitable fabric over a frame composed of two parallel transverse spars 3, extending from side to side of the machine, their ends being connected by bows 4, extending from front to rear of the machine. The front and rear spars 3 of each aeroplane are connected by a series of parallel ribs 5, which preferably extend somewhat beyond the rear spar, as shown. These spars, bows, and ribs are preferably constructed of wood having the necessary strength, combined with lightness and flexibility. Upon this framework the cloth which forms the supporting-surface of the aeroplane is secured,

the frame being inclosed in the cloth. The cloth for each aeroplane previously to its attachment to its frame is cut on the bias and made up in a single piece approximately the size and shape of the aeroplane, having the threads of the fabric arranged diagonally to the transverse spars and longitudinal ribs, as indicated at 6 in Fig. 2. Thus the diagonal threads of the cloth form truss systems with the spars and ribs, the threads constituting the diagonal members. A hem is formed at the rear edge of the cloth to receive a wire 7, which is connected to the ends of the rear spar and supported by the rearwardly-extending ends of the longitudinal ribs 5, thus forming a rearwardly-extending flap or portion of the aeroplane. This construction of the aeroplanes gives a surface which has very great strength to withstand lateral and longitudinal strains, at the same time being capable of being bent or twisted in the manner hereinafter described.

When two aeroplanes are employed, as in the construction illustrated, they are connected together by upright standards 8. These standards are substantially rigid, being preferably constructed of wood and of equal length, equally spaced along the front and rear edges of the aeroplane, to which they are connected at their top and bottom ends by hinged joints or universal joints of any suitable description. We have shown one form of connection which may be used for this purpose in Figs. 4 and 5 of the drawings. In this construction each end of the standard 8 has secured to it an eye 9, which engages with a hook 10, secured to a bracket-plate 11, which latter plate is in turn fastened to the spar 3. Diagonal braces or stay wires 12 extend from each end of each standard to the opposite ends of the adjacent standards, and as a convenient mode of attaching these parts I have shown a hook 13 made integral with the hook 10 to receive the end of one of the stay-wires, the other stay-wire being mounted on the hook 10. The hook 13 is shown as bent down to retain the stay-wire in connection to it, while the hook 10 is shown as provided with a pin 14 to hold the stay-wire 12 and eye 9 in position thereon. It will be seen that this construction forms a truss system which gives the whole machine great transverse rigidity and strength, while at the same time the jointed connections of the parts permit the aeroplanes to be bent or twisted in the manner which we will now proceed to describe.

15 indicates a rope or other flexible connection extending lengthwise of the front of the machine above the lower aeroplane, passing under pulleys or other suitable guides 16 at the front corners e and f of the lower aeroplane, and extending thence upward and rearward to the upper rear corners c and d of the upper aeroplane, where they are attached, as indicated at 17. To the central portion of this rope there is connected a laterally-movable cradle 18, which forms a means for moving the rope lengthwise in one direction or the other, the cradle being movable toward either side of the machine. We have devised this cradle as a convenient means for operating the rope 15, and the machine is intended to be generally used with the operator lying face downward on the lower aeroplane, with his head to the front, so that the operator's body rests on the cradle, and the cradle can be moved laterally by the movements of the operator's body. It will be understood, however, that the rope 15 may be manipulated in any suitable manner.

19 indicates a second rope extending transversely of the machine along the rear edge of the body portion of the lower aeroplane, passing under suitable pulleys or guides 20 at the rear corners g and h of the lower aeroplane and extending thence diagonally upward to

the front corners a and b of the upper aeroplane, where its ends are secured in any suitable manner, as indicated at 21.

Considering the structure so far as we have now described it and assuming that the cradle 18 be moved to the right in Figs. 1 and 2, as indicated by the arrows applied to the cradle in Fig. 1 and by the dotted lines in Fig. 2, it will be seen that that portion of the rope 15 passing under the guide-pulley at the corner e and secured to the corner d will be under tension, while slack is paid out throughout the other side or half of the rope 15. The part of the rope 15 under tension exercises a downward pull upon the rear upper corner d of the structure and an upward pull upon the front lower corner e, as indicated by the arrows. This causes the corner d to move downward and the corner e to move upward. As the corner e moves upward it carries the corner a upward with it, since the intermediate standard 8 is substantially rigid and maintains an equal distance between the corners a and e at all times. Similarly, the standard 8, connecting the corners d and h, causes the corner h to move downward in unison with the corner d. Since the corner a thus moves upward and the corner h moves downward, that portion of the rope 19 connected to the corner a will be pulled upward through the pulley 20 at the corner h, and the pull thus exerted on the rope 19 will pull the corner b on the other side of the machine downward and at the same time pull the corner g at said other side of the machine upward. This results in a downward movement of the corner b and an upward movement of the corner c. Thus it results from a lateral movement of the cradle 18 to the right in Fig. 1 that the lateral margins a d and e h at one side of the machine are moved from their normal positions, in which they lie in the normal planes of their respective aeroplanes, into angular relations with said normal planes, each lateral margin on this side of the machine being raised above said normal plane at its forward end and depressed below said normal plane at its rear end, said lateral margins being thus inclined upward and forward. At the same time a reverse inclination is imparted to the lateral margins b c and f g at the other side of the machine, their inclination being downward and forward. These positions are indicated in dotted lines in Fig. 1 of the drawings. A movement of the cradle 18 in the opposite direction from its normal position will reverse the angular inclination of the lateral margins of the aeroplanes in an obvious manner. By reason of this construction it will be seen that with the particular mode of construction now under consideration it is possible to move the forward corner of the lateral edges of the aeroplane on one side of the machine either above or below the normal planes of the aeroplanes, a reverse movement of the forward corners of the lateral margins on the other side of the machine occurring simultaneously. During this operation each aeroplane is twisted or distorted around a line extending centrally across the same from the middle of one lateral margin to the middle of the other lateral margin, the twist due to the moving of the lateral margins to different angles extending across each aeroplane from side to side, so that each aeroplane-surface is given a helicoidal warp or twist. We prefer this construction and mode of operation for the reason that it gives a gradually-increasing angle to the body of each aeroplane from the central longitudinal line thereof outward to the margin, thus giving a continuous surface on each side of the machine, which has a gradually increasing or decreasing angle of incidence from the center of the machine to either side. We wish it to be understood, however, that our invention is not limited to this particular construction,

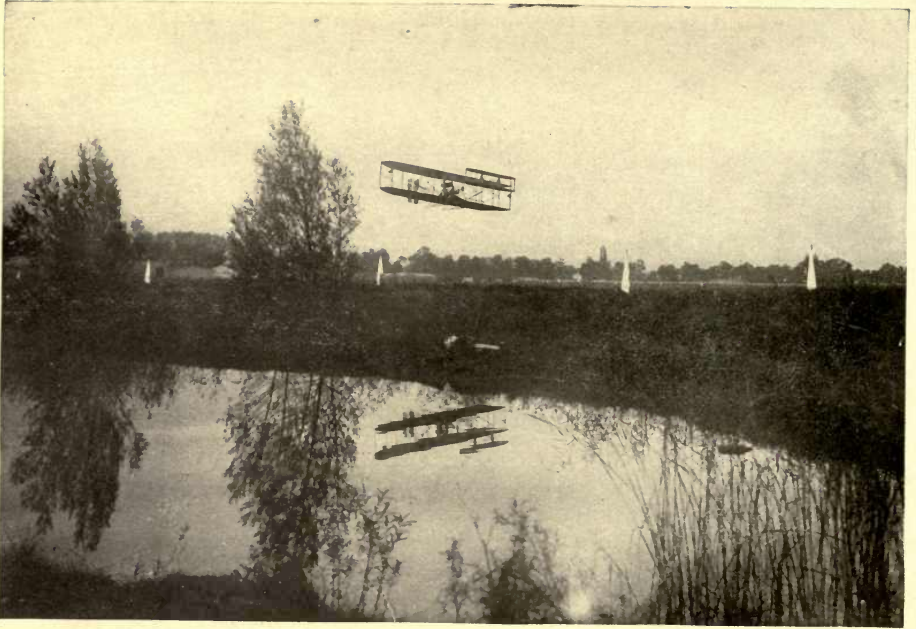

Count de Lambert in Wright Biplane at Juvisy, France.

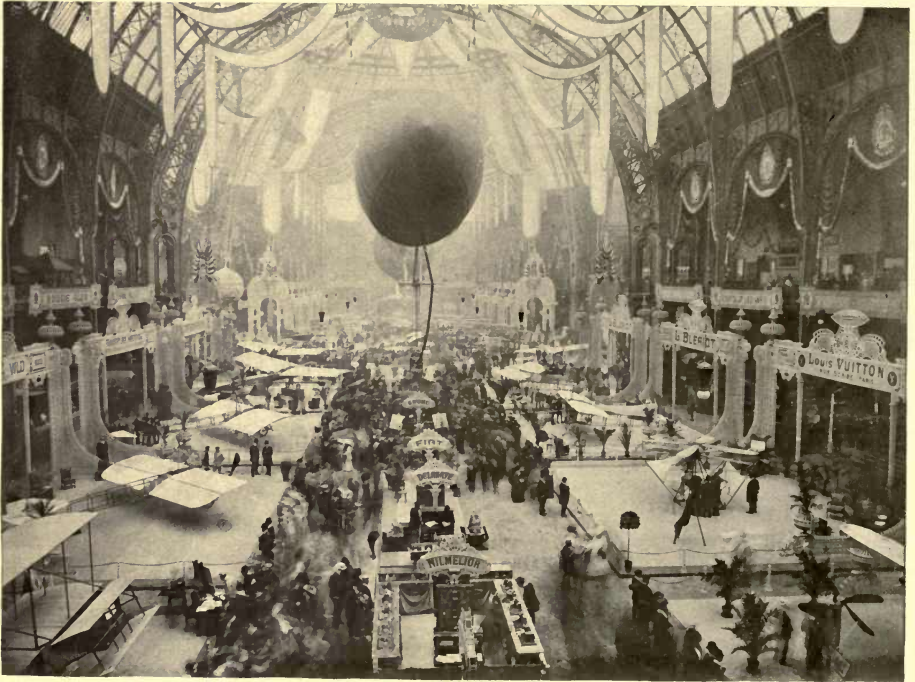

FIGURE 254.—View down main hall of Paris Aeronautical Salon, which closed October 15, 1909. The value of the exhibits and accessories, the cost of the decorations, and the attendance was far greater than at any automobile show ever given in the United States or Europe. It was the second annual event of the kind to be held in Paris and a large number of orders for various makes of machines was placed for future delivery—110 being for one well-known monoplane.

No. 821,393

O. & W. WRIGHT,
FLYING MACHINE.

PATENTED MAY 22, 1906.

No. 821,393

O. & W. WRIGHT,
FLYING MACHINE.

PATENTED MAY 22, 1906.

No. 821,393

O. & W. WRIGHT,
FLYING MACHINE.

PATENTED MAY 22, 1906.

FIG. 1.

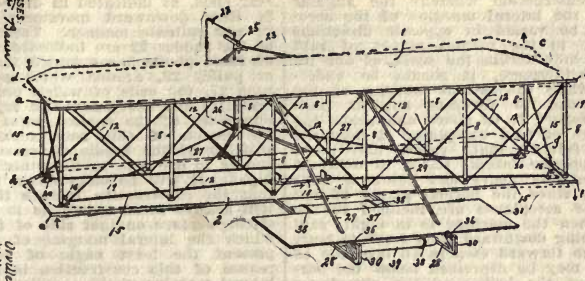

WITNESSES:
William G. Rowan,
James Miller.

INVENTORS:
Orville Wright,
Walter Wright.

WITNESSES:
William G. Rowan,
James Miller.

INVENTORS:
Orville Wright,
Walter Wright.

WITNESSES:
William G. Rowan,
James Miller.

INVENTORS:
Orville Wright,
Walter Wright.

FIG. 2.

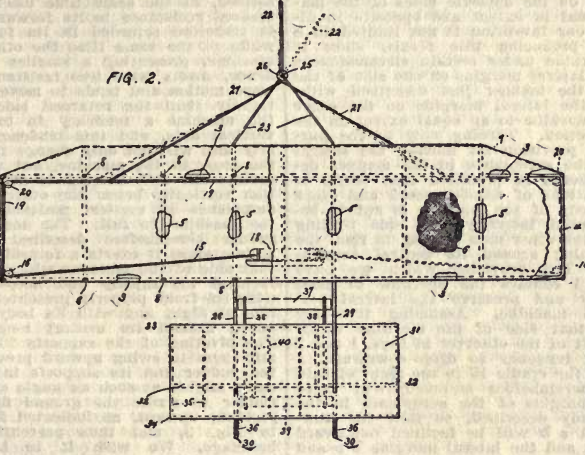

INVENTORS:
Orville Wright,
Walter Wright.

FIG. 3.

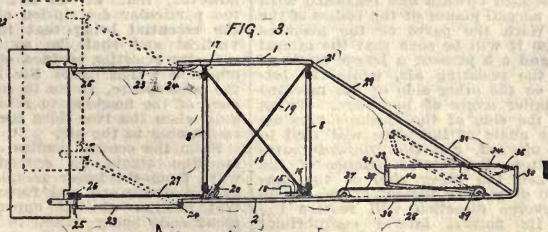

WITNESSES:
William G. Rowan,
James Miller.

FIG. 4.



INVENTORS:
Orville Wright,
Walter Wright.

FIG. 5.

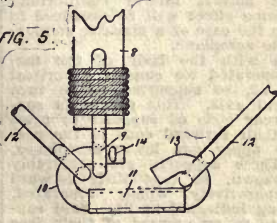

FIGURE 259.—Wright Patent Drawings.

since any construction whereby the angular relations of the lateral margins of the aeroplanes may be varied in opposite directions with respect to the normal planes of said aeroplanes comes within the scope of our invention. Furthermore, it should be understood that while the lateral margins of the aeroplanes move to different angular positions with respect to or above and below the normal planes of said aeroplanes it does not necessarily follow that these movements bring the opposite lateral edges to different angles respectively above and below a horizontal plane, since the normal planes of the bodies of the aeroplanes are inclined to the horizontal when the machine is in flight, said inclination being downward from front to rear, and while the forward corners on one side of the machine may be depressed below the normal planes of the bodies of the aeroplanes said depression is not necessarily sufficient to carry them below the horizontal planes passing through the rear corners on that side. Moreover, although we prefer to so construct the apparatus that the movements of the lateral margins on the opposite sides of the machine are equal in extent and opposite in direction, yet our invention is not limited to a construction producing this result, since it may be desirable under certain circumstances to move the lateral margins on one side of the machine in the manner just described without moving the lateral margins on the other side of the machine to an equal extent in the opposite direction. Turning now to the purpose of this provision for moving the lateral margins of the aeroplanes in the manner described, it should be premised that owing to various conditions of wind-pressure and other causes the body of the machine is apt to become unbalanced laterally, one side tending to sink and the other side tending to rise, the machine turning around its central longitudinal axis. The provision which we have just described enables the operator to meet this difficulty and preserve the lateral balance of the machine. Assuming that for some cause that side of the machine which lies to the left of the observer in Figs. 1 and 2 has shown a tendency to drop downward, a movement of the cradle 18 to the right of said figures, as hereinbefore assumed, will move the lateral margins of the aeroplanes in the manner already described, so that the margins *a d* and *e h* will be inclined downward and rearward and the lateral margins *b c* and *f g* will be inclined upward and rearward with respect to the normal planes of the bodies of the aeroplanes. With the parts of the machine in this position it will be seen that the lateral margins *a d* and *e h* present a larger angle of incidence to the resisting air, while the lateral margins on the other side of the machine present a smaller angle of incidence. Owing to this fact, the side of the machine presenting the larger angle of incidence will tend to lift or move upward, and this upward movement will restore the lateral balance of the machine. When the other side of the machine tends to drop, a movement of the cradle 18 in the reverse direction will restore the machine to its normal lateral equilibrium. Of course the same effect will be produced in the same way in the case of a machine employing only a single aeroplane.

In connection with the body of the machine as thus operated we employ a vertical rudder or tail 22, so supported as to turn around a vertical axis. This rudder is supported at the rear ends of supports or arms 23, pivoted at their forward ends to the rear margins of the upper and lower aeroplanes, respectively. These supports are preferably V-shaped, as shown, so that their forward ends are comparatively widely separated, their pivots being indicated at 24. Said supports are free to swing upward at their free

rear ends, as indicated in dotted lines in Fig. 3, their downward movement being limited in any suitable manner. The vertical pivots of the rudder 22 are indicated at 25, and one of these pivots has mounted thereon a sheave or pulley 26, around which passes a thimble-roped rope 27, the ends of which are extended out laterally and secured to the rope 19 on opposite sides of the central point of said rope. By reason of this construction the lateral shifting of the cradle 18 serves to turn the rudder to one side or the other of the line of flight. It will be observed in this connection that the construction is such that the rudder will always be so turned as to present its resisting-surface on that side of the machine on which the lateral margins of the aeroplanes present the least angle of resistance. The reason of this construction is that when the lateral margins of the aeroplanes are so turned in the manner hereinbefore described as to present different angles of incidence to the atmosphere that side presenting the largest angle of incidence, although being lifted or moved upward in the manner already described, at the same time meets with an increased resistance to its forward motion, and is therefore retarded in its forward motion, while at the same time the other side of the machine, presenting a smaller angle of incidence, meets with less resistance to its forward motion and tends to move forward more rapidly than the retarded side. This gives the machine a tendency to turn around its vertical axis, and this tendency if not properly met will not only change the direction of the front of the machine, but will ultimately permit one side thereof to drop into a position vertically below the other side with the aeroplanes in vertical position, thus causing the machine to fall. The movement of the rudder hereinbefore described prevents this action, since it exerts a retarding influence on that side of the machine which tends to move forward too rapidly and keeps the machine with its front properly presented to the direction of flight and with its body properly balanced around its central longitudinal axis. The pivoting of the supports 23 so as to permit them to swing upward prevents injury to the rudder and its supports in case the machine alights at such an angle as to cause the rudder to strike the ground first, the parts yielding upward, as indicated in dotted lines in Fig. 3, and thus preventing injury or breakage. We wish it to be understood, however, that we do not limit ourselves to the particular description of rudder set forth, the essential being that the rudder shall be vertical and shall be so moved as to present its resisting-surface on that side of the machine which offers the least resistance to the atmosphere, so as to counteract the tendency of the machine to turn around a vertical axis when the two sides thereof offer different resistances to the air.

From the central portion of the front of the machine struts 28 extend horizontally forward from the lower aeroplane, and struts 29 extend downward and forward from the central portion of the upper aeroplane, their front ends being united to the struts 28, the forward extremities of which are turned up, as indicated at 30. These struts 28 and 29 form truss-skids projecting in front of the whole frame of the machine and serving to prevent the machine from rolling over forward when it alights. The struts 29 serve to brace the upper portion of the main frame and resist its tendency to move forward after the lower aeroplane has been stopped by its contact with the earth, thereby relieving the rope 19 from undue strain, for it will be understood that when the machine comes into contact with the earth further forward movement of the lower portion thereof being suddenly arrested the inertia of the upper

portion would tend to cause it to continue to move forward if not prevented by the struts 20, and this forward movement of the upper portion would bring a very violent strain upon the rope 19, since it is fastened to the upper portion at both of its ends, while its lower portion is connected by the guides 20 to the lower portion. The struts 28 and 29 also serve to support the front or horizontal rudder, the construction of which we will now proceed to describe.

The front rudder 31 is a horizontal rudder having a flexible body, the same consisting of three stiff cross-pieces or sticks 32, 33, and 34, and the flexible ribs 35, connecting said cross-pieces and extending from front to rear. The frame thus provided is covered by a suitable fabric stretched over the same to form the body of the rudder. The rudder is supported from the struts 29 by means of the intermediate cross-piece 32, which is located near the center of pressure slightly in front of a line equidistant between the front and rear edges of the rudder, the cross-piece 32 forming the pivotal axis of the rudder, so as to constitute a balanced rudder. To the front edge of the rudder there are connected springs 36, which springs are connected to the upturned ends 30 of the struts 28, the construction being such that said springs tend to resist any movement either upward or downward of the front edge of the horizontal rudder. The rear edge of the rudder lies immediately in front of the operator and may be operated by him in any suitable manner. We have shown a mechanism for this purpose comprising a roller or shaft 37, which may be grasped by the operator so as to turn the same in either direction. Bands 38 extend from the roller 37 forward to and around a similar roller or shaft 39, both rollers or shafts being supported in suitable bearings on the struts 28. The forward roller or shaft has rearwardly-extending arms 40, which are connected by links 41 with the rear edge of the rudder 31. The normal position of the rudder 31 is neutral or substantially parallel with the aeroplanes 1 and 2; but its rear edge may be moved upward or downward, so as to be above or below the normal plane of said rudder through the mechanism provided for that purpose. It will be seen that the springs 36 will resist any tendency of the forward edge of the rudder to move in either direction, so that when force is applied to the rear edge of said rudder the longitudinal ribs 35 bend, and the rudder thus presents a concave surface to the action of the wind either above or below its normal plane, said surface presenting a small angle of incidence at its forward portion and said angle of incidence rapidly increasing toward the rear. This greatly increases the efficiency of the rudder as compared with a plane surface of equal area. By regulating the pressure on the upper and lower sides of the rudder through changes of angle and curvature in the manner described a turning movement of the main structure around its transverse axis may be effected, and the course of the machine may thus be directed upward or downward at the will of the operator and the longitudinal balance thereof maintained.

Contrary to the usual custom, we place the horizontal rudder in front of the aeroplanes at a negative angle and employ no horizontal tail at all. By this arrangement we obtain a forward surface which is almost entirely free from pressure under ordinary conditions of flight, but which even if not moved at all from its original position becomes an efficient lifting-surface whenever the speed of the machine is accidentally reduced very much below the normal, and thus largely counteracts that backward travel of the center of pressure on the aeroplanes which has frequently been productive of serious injuries

by causing the machine to turn downward and forward and strike the ground head-on. We are aware that a forward horizontal rudder of different construction has been used in combination with a supporting-surface and a rear horizontal rudder; but this combination was not intended to effect and does not effect the object which we obtain by the arrangement hereinbefore described.

We have used the term "aeroplane" in this specification and the appended claims to indicate the supporting-surface or supporting-surfaces by means of which the machine is sustained in the air, and by this term we wish to be understood as including any suitable supporting-surface which normally is substantially flat, although of course when constructed of cloth or other flexible fabric, as we prefer to construct them, these surfaces may receive more or less curvature from the resistance of the air, as indicated in Fig. 3.

We do not wish to be understood as limiting ourselves strictly to the precise details of construction hereinbefore described and shown in the accompanying drawings, as it is obvious that these details may be modified without departing from the principles of our invention. For instance, while we prefer the construction illustrated in which each aeroplane is given a twist along its entire length in order to set its opposite lateral margins at different angles we have already pointed out that our invention is not limited to this form of construction, since it is only necessary to move the lateral marginal portions, and where these portions alone are moved only those upright standards which support the movable portion require flexible connections at their ends.

Having thus fully described our invention, what we claim as new, and desire to secure by Letters Patent, is—

1. In a flying-machine, a normally flat aeroplane having lateral marginal portions capable of movement to different positions above or below the normal plane of the body of the aeroplane, such movement being about an axis transverse to the line of flight, whereby said lateral marginal portions may be moved to different angles relatively to the normal plane of the body of the aeroplane, so as to present to the atmosphere different angles of incidence, and means for so moving said lateral marginal portions, substantially as described.

2. In a flying-machine, the combination, with two normally parallel aeroplanes, superposed the one above the other, of upright standards connecting said planes at their margins, the connections between the standards and aeroplanes at the lateral portions of the aeroplanes being by means of flexible joints, each of said aeroplanes having lateral marginal portions capable of movement to different positions above or below the normal plane of the body of the aeroplane, such movement being about an axis transverse to the line of flight, whereby said lateral marginal portions may be moved to different angles relatively to the normal plane of the body of the aeroplane, so as to present to the atmosphere different angles of incidence, the standards maintaining a fixed distance between the portions of the aeroplanes which they connect, and means for imparting such movement to the lateral marginal portions of the aeroplanes, substantially as described.

3. In a flying-machine, a normally flat aeroplane having lateral marginal portions capable of movement to different positions above or below the normal plane of the body of the aeroplane, such movement being about an axis transverse to the line of flight, whereby said lateral marginal portions may be moved to different angles relatively to the normal plane of the body of the aeroplane, and also to different angles relatively to each

other, so as to present to the atmosphere different angles of incidence, and means for simultaneously imparting such movement to said lateral marginal portions, substantially as described.

4. In a flying-machine, the combination, with parallel superposed aeroplanes, each having lateral marginal portions capable of movement to different positions above or below the normal plane of the body of the aeroplane, such movement being about an axis transverse to the line of flight, whereby said lateral marginal portions may be moved to different angles relatively to the normal plane of the body of the aeroplane, and to different angles relatively to each other, so as to present to the atmosphere different angles of incidence, of uprights connecting said aeroplanes at their edges, the uprights connecting the lateral portions of the aeroplanes being connected with said aeroplanes by flexible joints, and means for simultaneously imparting such movement to said lateral marginal portions, the standards maintaining a fixed distance between the parts which they connect, whereby the lateral portions on the same side of the machine are moved to the same angle, substantially as described.

5. In a flying-machine, an aeroplane having substantially the form of a normally flat rectangle elongated transversely to the line of flight, in combination with means for imparting to the lateral margins of said aeroplane a movement about an axis lying in the body of the aeroplane perpendicular to said lateral margins, and thereby moving said lateral margins into different angular relations to the normal plane of the body of the aeroplane, substantially as described.

6. In a flying-machine, the combination, with two superposed and normally parallel aeroplanes, each having substantially the form of a normally flat rectangle elongated transversely to the line of flight, of upright standards connecting the edges of said aeroplanes to maintain their equidistance, those standards at the lateral portions of said aeroplanes being connected therewith by flexible joints, and means for simultaneously imparting to both lateral margins of both aeroplanes a movement about axes which are perpendicular to said margins and in the planes of the bodies of the respective aeroplanes, and thereby moving the lateral margins on the opposite sides of the machine into different angular relations to the normal planes of the respective aeroplanes, the margins on the same side of the machine moving to the same angle, and the margins on one side of the machine moving to an angle different from the angle to which the margins on the other side of the machine move, substantially as described.

7. In a flying-machine, the combination, with an aeroplane, and means for simultaneously moving the lateral portions thereof into different angular relations to the normal plane of the body of the aeroplane and to each other, so as to present to the atmosphere different angles of incidence, of a vertical rudder, and means whereby said rudder is caused to present to the wind that side thereof nearest the side of the aeroplane having the smaller angle of incidence and offering the least resistance to the atmosphere, substantially as described.

8. In a flying-machine, the combination, with two superposed and normally parallel aeroplanes, upright standards connecting the edges of said aeroplanes to maintain their equidistance, those standards at the lateral portions of said aeroplanes being connected therewith by flexible joints, and means for simultaneously moving both lateral portions of both aeroplanes into different angular relations to the normal planes of the bodies of the respective aeroplanes, the lateral por-

tions on one side of the machine being moved to an angle different from that to which the lateral portions on the other side of the machine are moved, so as to present different angles of incidence at the two sides of the machine, of a vertical rudder, and means whereby said rudder is caused to present to the wind that side thereof nearest the side of the aeroplanes having the smaller angle of incidence and offering the least resistance to the atmosphere, substantially as described.

9. In a flying-machine, an aeroplane normally flat and elongated transversely to the line of flight, in combination with means for imparting to said aeroplane a helicoidal warp around an axis transverse to the line of flight and extending centrally along the body of the aeroplane in the direction of the elongation of the aeroplane, substantially as described.

10. In a flying-machine, two aeroplanes, each normally flat and elongated transversely to the line of flight, and upright standards connecting the edges of said aeroplanes to maintain their equidistance, the connections between said standards and aeroplanes being by means of flexible joints, in combination with means for simultaneously imparting to each of said aeroplanes a helicoidal warp around an axis transverse to the line of flight and extending centrally along the body of the aeroplane in the direction of the elongation of the aeroplane, substantially as described.

11. In a flying-machine, two aeroplanes, each normally flat and elongated transversely to the line of flight, and upright standards connecting the edges of said aeroplanes to maintain their equidistance, the connections between such standards and aeroplanes being by means of flexible joints, in combination with means for simultaneously imparting to each of said aeroplanes a helicoidal warp around an axis transverse to the line of flight and extending centrally along the body of the aeroplane in the direction of the elongation of the aeroplane, a vertical rudder, and means whereby said rudder is caused to present to the wind that side thereof nearest the side of the aeroplanes having the smaller angle of incidence and offering the least resistance to the atmosphere, substantially as described.

12. In a flying-machine, the combination, with an aeroplane, of a normally flat and substantially horizontal flexible rudder, and means for curving said rudder rearwardly and upwardly or rearwardly and downwardly with respect to its normal plane, substantially as described.

13. In a flying-machine, the combination, with an aeroplane, of a normally flat and substantially horizontal flexible rudder pivotally mounted on an axis transverse to the line of flight near its center, springs resisting vertical movement of the front edge of said rudder, and means for moving the rear edge of said rudder above or below the normal plane thereof, substantially as described.

14. A flying-machine comprising superposed connected aeroplanes, means for moving the opposite lateral portions of said aeroplanes to different angles to the normal planes thereof, a vertical rudder, means for moving said vertical rudder toward that side of the machine presenting the smaller angle of incidence and the least resistance to the atmosphere, and a horizontal rudder provided with means for presenting its upper or under surface to the resistance of the atmosphere, substantially as described.

15. A flying-machine comprising superposed connected aeroplanes, means for moving the opposite lateral portions of said aeroplanes to different angles to the normal planes thereof, a vertical rudder, means for moving said vertical rudder toward that side of the machine presenting the smaller angle

of incidence and the least resistance to the atmosphere, and a horizontal rudder provided with means for presenting its upper or under surface to the resistance of the atmosphere, said vertical rudder being located at the rear of the machine and said horizontal rudder at the front of the machine, substantially as described.

16. In a flying-machine, the combination, with two superposed and connected aeroplanes, of an arm extending rearward from each aeroplane, said arms being parallel and free to swing upward at their rear ends, and a vertical rudder pivotally mounted in the rear ends of said arms, substantially as described.

17. A flying-machine comprising two superposed aeroplanes, normally flat but flexible, upright standards connecting the margins of said aeroplanes, said standards being connected to said aeroplanes by universal joints, diagonal stay-wires connecting the opposite ends of the adjacent standards, a rope extending along the front edge of the lower aeroplane, passing through guides at the front corners thereof, and having its ends secured to the rear corners of the upper aeroplane, and a rope extending along the rear edge of the lower aeroplane, passing through

guides at the rear corners thereof, and having its ends secured to the front corners of the upper aeroplane, substantially as described.

18. A flying-machine comprising two superposed aeroplanes, normally flat but flexible, upright standards connecting the margins of said aeroplanes, said standards being connected to said aeroplanes by universal joints, diagonal stay-wires connecting the opposite ends of the adjacent standards, a rope extending along the front edge of the lower aeroplane, passing through guides at the front corners thereof, and having its ends secured to the rear corners of the upper aeroplane, and a rope extending along the rear edge of the lower aeroplane, passing through guides at the rear corners thereof, and having its ends secured to the front corners of the upper aeroplane, in combination with a vertical rudder, and a tiller-rope connecting said rudder with the rope extending along the rear edge of the lower aeroplane, substantially as described.

ORVILLE WRIGHT
WILBUR WRIGHT.

Witnesses:

Chas. E. Taylor,
E. Earle Forrer

Specification and Claims of Montgomery Patent.

No. 831,173.

Filed April 26, 1905. Issued September 18, 1906.

Expires September 18, 1923.

To all whom it may concern:

Be it known that I, John J. Montgomery, a citizen of the United States, residing at Santa Clara, county of Santa Clara, State of California, have invented certain new and useful improvements in Aeroplanes; and I do hereby declare the following to be a full, clear, and exact description of the same.

My invention relates to the class of aeroplanes; and it consists in certain surfaces with means for adjusting them, as I shall hereinafter fully describe.

The object of my invention is to provide a controllable aeroplane device.

Referring to the accompanying drawings, Figure 1 is a side elevation of my aeroplane device. Fig. 2 is a top plan of the same. Fig. 3 is a front view of the same. Fig. 4 is a plan, enlarged, of one side of one wing-surface. Fig. 5 is a cross-section on the line $x x$ of Fig. 4. Fig. 6 is a detail view of the controlling wires and cords which change the surface of the aeroplane. Fig. 7 is a detail view of the same adapted for the rear wing-surface of the aeroplane. Fig. 7 is a detail view of the same adapted for the rear wing-surface in order to vary its inclination to the front wing-surface.

In the form of the device here illustrated, there is a front wing-surface A, a rear wing-surface B, and a horizontal tail-surface C. The wing-surfaces A and B in fore-and-aft or transverse section are curved, the most perfect form of the curve being that of a parabola, whereby the curve in front is sharp and that in the back is relatively more gradual, as seen in Fig. 5. These two surfaces A and B are connected by the bars D of a frame.

The front portions a and b, respectively, of the wing-surfaces are best curved down from center to ends, as seen in Fig. 3, and are firmly attached to the fore-and-aft bars D at the points d. They are also strongly braced in all directions by wires d', running to vertical frame-posts d² and to the frame-bars D. The rear portions a' and b', respectively, of the wing-surfaces are hinged midway of their length, where their stiffener-bars are severed and hinged together at a² and b², so that said rear portions are free to droop, but are restrained from upward movement by a series of wires E, attached to the lower beam F of the frame in a manner which I shall

presently describe. These rear portions a' and b' simply rest on the frame-bars D, and thereby having their freedom of movement can assume various positions, like the arms of a balance, thus causing a change in the form of the wing-surfaces on the two sides. This change of surface is for the purpose of guidance and partly for equilibrium and is produced by the following means. The wires E, which are attached above to the rear portion a' of the front wing-surface A, pass downwardly from each side of said portion, the group of wires from each side being united below, as shown in Fig. 6, to opposite ends of an equalizing-cable e through the intervention of a ring. The equalizing-cable e plays freely through a pulley e', secured on top of the lower beam F of the frame of the machine. Secured to the wing terminals of the equalizer-cable e are cords e², which pass therefrom to the beam and cross each other through a guide e⁴ on said beam, and thence said cords pass downwardly and backwardly, as seen in Fig. 1, and are attached to the ends of a cross-foot or stirrup-bar G, as seen in Figs. 2 and 3. The wires E, which are attached above to the rear portion b' of the rear wing-surface B, pass downwardly from each side of said portion, the groups of wires from each side being united below, as shown in Fig. 7, to opposite ends of an equalizing-cable similar to the cable e in front and similarly lettered, through the intervention of a ring. This rear equalizing-cable instead of being guided by a pulley firmly attached to the beam F is guided and plays freely through the upper pulley of a triple sheave, (lettered e³), which sheave is connected with and held by a cord J, attached to it. This cord J passes freely through a hole in beam F, as seen in Fig. 7, and is thence guided by a pulley j under the beam to a point forward, as shown in Fig. 1, to within reach of the operator. Cords e² are secured to the terminal rings of the rear equalizer-cable, e, as shown in Fig. 7, and thence are guided by the lateral pulleys of the triple sheave e³ downwardly and backwardly to the foot or stirrup bar G, as seen in Figs. 2 and 1. By pressing down on the stirrup-bar on one side the rear portions of the wing-surfaces on one side are drawn down, while those on the opposite side are allowed to yield to the air-pressure be-

neath. By these means the wing-surfaces change their form. The pressures on the two sides of the device are varied, and the device may keep its course when meeting a gust, which would tend to tilt it and turn it aside, or it may be made to change its course.

A feature of the arrangement of the cords e^2 (indicated in Fig. 6) is that the one attached to the left arms passes through the guide E^1 to the right end of the stirrup-bar, and vice versa. Thus a pressure with the right foot will force down the left rear surfaces, making this the stronger side of the device, while the right rear surfaces yielding become the weaker. These changes cause the device to swing to the right.

By simultaneously pressing on both ends of the stirrup-bar all the rear portions of both wing-surfaces are depressed for the purpose of partly meeting the requirements of the fore and aft equilibrium; but this is mainly done by varying the relative inclination of one of the wing-surfaces to that of the other. This last-named variation involves both fore and aft equilibrium and continuance of flight, as I shall presently explain. This adjustment of inclination is accomplished by allowing the free rear portion of the rear wing-surface B to rise under the pressure of the air and, by pulling it down again as required by means of its wires E and cords e^2 , heretofore described, which, as shown in Fig. 7, are adapted for this independent use as the pulleys e^3 of the rear control are not secured to the beam F, but are held by a separate cord J, which passes within reach of the operator, being guided by a pulley j.

In the rear of the device in connection with the tail-surface C there is a large surface H perpendicular to the tail-surface, attached to it and extending both above and below it. The tail-surface is adapted to swing vertically by being hinged at c to the rear of the wing-surface B and its movement is effected by means of a cord L, secured to it on each side, Fig. 1, said cord being suitably guided and attached to a sliding handhold I within reach of the operator.

The surface H moves vertically with the tail-surface; but it has no side movement, because its function is that of a keel or fin and not that of a rudder. It serves to maintain the side equilibrium, which it does by performing an operation different from that of a rudder. The essentials of this fin-like surface H are, first, that it shall be relatively large; second, that it shall be proximately to the rear surface, and, third, that it shall extend above and below the tail-surface C.

Concerning the fore and aft aligned wing-surfaces A and B there are two essential adjustments, first, that of the rear portions of each relatively to the front portions and, second, that of the inclination of one surface relatively to the other. By the first adjustment the surfaces undergo changes of form and the effect is to vary the air-pressures on the two sides of the machine, whereby the device may keep its course, being prevented from tilting or turning aside and may change its course. These results are based upon the essential character of a wing-surface. Investigation has shown me that a wing is a specially-formed surface placed in such a position as to develop a rotary movement in the surrounding air. This position is determined by mathematical considerations. The various requirements of gliding are met by changes in various parts of the wing. The movements in the air are of such a nature as to make it possible to separate the wing-surface, as I have done in my device, into front and rear sections and maintain the special rotary movement of the air which lies at the basis of this phenomenon. The sections though separated have a form and adjustment suitable to themselves, based upon the fundamental formula of formation and ad-

justment, but these must be coordinate to the idea of one larger wing of which they are supposed to be parts. By the second adjustment—namely, that of the inclination of one wing-surface relatively to the other—the machine maintains equilibrium and flight. If a surface moves at a slight angle through the air, the center of pressure is near the front edge, and the weight carried must be below this point. To meet the requirements of varying speeds of motion, it is necessary to either change the position of the weight or the angle of the surface. This in my device is done by changing the angle between the front and rear wing surfaces A and B. In the process of gliding there must be a continual change in the angle of these surfaces to maintain the proper speed and equilibrium.

Concerning the tail-surface C there must be an up-and-down or vertical adjustment. The tail-surface is in reality but an extension of the rear wing-surface B. By the variation of its angle the pressures in the rear are varied. The same variations are, indeed, produced if the tail be dispensed with and the rear wing-surface is changed in its angle. In other words, whether the tail be a separate surface or only an extension of the rear wing-surface it is enough to say that the rear surface must be adapted to change its angle in part or whole.

The effect of the fin-like surface H is this: If from any cause the machine is tilted to one side and it commences to glide sidewise, though the front parts have an unimpeded side movement, the rear part having the large fin H meets resistance and as a consequence the machine is swung around and continues to travel in the direction it started to fall. This of course takes the machine out of its course. To bring it back again, the wings must be operated as before described. Thus it will be seen this vertical fin-like surface has a distinctive character, due to its size and position, and, though apparently a rudder, is the reverse and not designed to perform the office of a rudder.

Heretofore I have described the wing-surfaces as being curved in cross-section, the best form being parabolic. It must now be noted that for the best results the form of each side of each wing-surface is specialized, as follows: All the fore-and-aft or cross sections are parabolic curves; but those curves nearer the center are most inclined to the path of movement and thence toward the ends their inclination is gradually decreased, thereby producing a sinuosity of the wing, as shown in Figs. 3 and 5, which is the normal surface from which the various changes are made. In addition to this adjustment or arrangement the curved cross-sections, beginning about two-thirds from the center, are less sharply curved in front, and so continue decreasing in sharp curvature to the ends. This is shown in Figs. 4 and 5, where in the successive sections 1, 2, 3, and 4 show the gradual cutting off at the front of the sharp beginning of the several parabolic curves. The first of these arrangements—namely, the gradual change in inclination of the cross-curves to the path of movement—is for the purpose of properly meeting and cutting the rising current of air immediately in front of the wing-surface, analysis and experiments having shown that the action of the under surface of a wing is to cause an ascending current of air immediately in front of the wing-surface, this ascending tendency being greatest at the center and gradually diminishing toward the tips. The second arrangement—namely, the diminishing curvature near the ends of the wing—of the forward end of the curves is for the same purpose, but is rendered necessary by the fact that if the foregoing adjustment of the surfaces were continued to the end the sharp curvature of the front edge would force the

N. 531,173.

J. J. MONTGOMERY, PATENTED SEPT. 16, 1906.
AEROPLANE.
APPLICATION FILED APR. 26, 1906.
1,689,775-43217 1

Fig. 6.



Fig. 1.

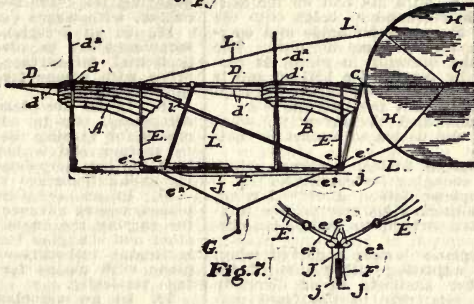

Fig. 7.



N. 531,173.

J. J. MONTGOMERY, PATENTED SEPT. 16, 1906.
AEROPLANE.
APPLICATION FILED APR. 26, 1906.
1,689,775-43217 2

Fig. 2.

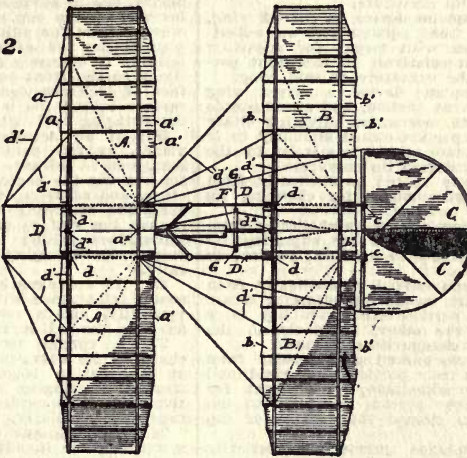

N. 531,173.

J. J. MONTGOMERY, PATENTED SEPT. 16, 1906.
AEROPLANE.
APPLICATION FILED APR. 26, 1906.
1,689,775-43217 3

Fig. 3.

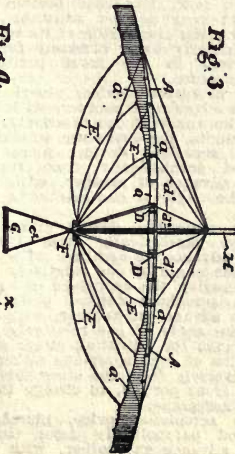

Fig. 4.

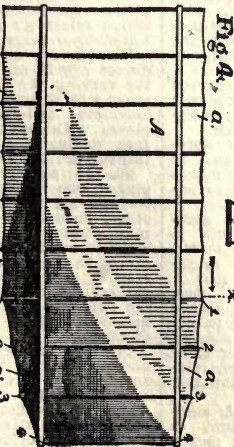

Fig. 5.



Witnesses
Oscar R. Dean
J. Campbell.

Inventor:
John J. Montgomery
by John J. Dean
his attorney

Witnesses
Oscar R. Dean
J. Campbell.

Inventor:
John J. Montgomery
by John J. Dean
his attorney

Witnesses
Oscar R. Dean
J. Campbell.

Inventor:
John J. Montgomery
by John J. Dean
his attorney

FIGURE 260.—Montgomery Patent Drawings.

rear portions of the surface into a too abrupt position relative to its path, thus building up a large unnecessary resistance to the forward movement.

In using the aeroplane the operator sits astride the beam F, with his feet on the stirrup-bar G. With one hand he holds onto the frame and with the other he holds and operates the cord L for adjusting the tail. The machine, with the operator in place, is carried to a height by means of a balloon and is launched from any desired elevation by tripping its connections with the balloon.

Having thus described the invention, what I claim as new, and desire to protect by Letters Patent, is—

1. In an aeroplane device, a curved wing, with means for changing its curvature.

2. In an aeroplane device, a curved wing, with means for adjusting its rear portion relatively to its front portion, to change its curvature.

3. In an aeroplane device, a curved wing, with means for adjusting either side of its rear portion either similarly to or diversely from the other, relatively to the front portion, to change its curvature.

4. In an aeroplane device, a curved wing, having a rigid front portion and an adjustable rear portion with means for adjusting said rear portion relatively to the front portion to change the curvature of said wing.

5. In an aeroplane device, a curved wing having a rigid front portion, and an adjustable rear portion, with means for adjusting either side of its rear portion either similarly to or diversely from the other, relatively to the front portion, to change its curvature.

6. An aeroplane curved parabolically from front to rear, with means for changing its surface.

7. An aeroplane curved parabolically from front to rear with means for adjusting its rear portion relatively to its front portion, to change its surface.

8. An aeroplane curved parabolically from front to rear with means for adjusting either side of its rear portion either similarly to or diversely from the other, relatively to the front portion, to change its curvature.

9. An aeroplane curved parabolically from front to rear, its front portion being rigid, and its rear portion adjustable, with means for adjusting said rear portion relatively to the front portion, to change the surface of the aeroplane.

10. An aeroplane curved parabolically from front to rear, its front portion being rigid, and its rear portion adjustable, with means for adjusting either side of its rear portion either similarly to or diversely from the other, relatively to the front portion, to change its curvature.

11. In an aeroplane device, plural curved wings, one in advance of another, with means for varying the angle of one relatively to another and changing the curvature of each.

12. In an aeroplane device, plural aeroplanes curved parabolically from front to rear, one in advance of another, with means for varying the angle of one relatively to another.

13. In an aeroplane device plural aeroplanes curved parabolically from front to rear, one in advance of another, with means for varying the angle of one relatively to another, and changing the curvature of each.

14. In an aeroplane device, plural aeroplanes, one in advance of another, with means for varying the angle of one relatively to another, and means for adjusting either side of the rear portion of each aeroplane either similarly to or diversely from the other side, relatively to the front portion, to change the surface of each aeroplane.

15. In an aeroplane device, plural aeroplanes, curved parabolically from front to rear, one in advance of another, with means

for varying the angle of one relatively to another, and adjusting the rear portion of each aeroplane relatively to its front portion to change the surface of each.

16. A curved aeroplane with means for changing its curvature, and a horizontal tail behind, with means for swinging it vertically.

17. In an aeroplane device, plural curved aeroplanes one in advance of another, and a horizontal tail-surface behind the last aeroplane with means for swinging said tail-surface vertically.

18. In an aeroplane device, plural curved aeroplanes, one in advance of another, with means for varying the angle of one relatively to another and a horizontal tail-surface behind the last aeroplane with means for swinging said tail-surface vertically.

19. In an aeroplane device, plural aeroplanes, one in advance of another, with means for varying the angle of one relatively to another and changing the surface of each, and a horizontal tail-surface behind the last aeroplane with means for swinging said tail-surface vertically.

20. In an aeroplane device, plural aeroplanes, one in advance of another, with means for varying the angle of one relatively to another, means for adjusting either side of the rear portion of each aeroplane either similarly to or diversely from the other side, relatively to the front portion, to change the surface of each aeroplane, and a horizontal tail-surface behind the last aeroplane with means for swinging said tail-surface vertically.

21. In an aeroplane device, plural aeroplanes, curved parabolically from front to rear, one in advance of another, with means for varying the angle of one relatively to another, and adjusting the rear portions of each aeroplane relatively to its front portions to change the surface of each, and a horizontal tail-surface behind the last aeroplane with means for swinging said tail-surface vertically.

22. An aeroplane having at its rear a horizontal tail-surface with means for swinging it vertically, and a relatively large fin-surface fixed to the tail-surface perpendicularly.

23. A curved aeroplane with means for changing its curvature said aeroplane having at its rear a horizontal tail-surface, with means for swinging it vertically, and a relatively large fin-surface fixed to the tail-surface perpendicularly.

24. An aeroplane device comprising plural aeroplanes one in advance of another, a horizontal tail-surface at the rear of the last aeroplane with means for swinging it vertically, and a relatively large fin-surface fixed to the tail-surface perpendicularly.

25. In an aeroplane device, plural aeroplanes one in advance of another, with means for varying the angle of one relatively to another and changing the surface of each, and a horizontal tail-surface behind the last aeroplane, with means for swinging said tail-surface vertically, and a fin-surface fixed to the tail-surface perpendicularly.

26. In an aeroplane device, plural aeroplanes, one in advance of another, with means for varying the angle of one relatively to another, means for adjusting either side of the rear portion of each aeroplane either similarly to or diversely from the other side, relatively to the front portion, to change the surface of each aeroplane, and a horizontal tail-surface behind the last aeroplane with means for swinging said tail-surface vertically, and a fin-surface fixed to the tail-surface perpendicularly.

27. In an aeroplane device, plural aeroplanes, curved parabolically from front to rear, one in advance of another, with means for varying the angle of one relatively to another, and adjusting the rear portion of each aeroplane relatively to its front portion to change the surface of each and a horizontal

tail-surface behind the last aeroplane, with means for swinging said tail-surface vertically, and a fin-surface fixed to the tail-surface perpendicularly.

28. A curved aeroplane with means for changing its curvature and provided with a fin-surface perpendicular thereto.

29. A curved aeroplane with means for changing its curvature and provided with a fin-surface perpendicular thereto and extending both above and below said aeroplane.

30. An aeroplane curved parabolically from front to rear.

31. An aeroplane curved parabolically from front to rear, its curves, in successive sections from center to ends, decreasing in inclination to the path of travel.

32. An aeroplane curved parabolically from front to rear, its sections near the ends being less sharply curved at their front ends than the forward ends of sections nearer the center.

33. An aeroplane curved parabolically from front to rear, its curves in successive sections from center to ends decreasing in inclination to the path of travel, and its sections near the ends being less sharply curved at their forward ends than the forward ends of sections nearer the center.

34. An aeroplane curved parabolically from front to rear, its curves in successive sections from center to ends decreasing in inclination to the path of travel, its sections near the ends being less sharply curved at their forward ends than the forward ends of sections near the center, and means for changing the surface of said aeroplane.

35. An aeroplane curved parabolically from front to rear, its curves in successive sections from center to ends decreasing in inclination to the path of travel, and its sections near the ends being less sharply curved at their forward ends than the forward ends of sections nearer the center, and means for adjusting the rear portion of said aeroplane relatively to its front portion.

36. An aeroplane curved parabolically from front to rear, its curves in successive sections from center to ends decreasing in inclination to the path of travel, and its sections near the ends being less sharply curved at their forward ends than the forward ends of sections nearer the center, the front portions of said aeroplane being rigid, and means for adjusting its rear portion relatively to its front portion, to change its surface.

37. In an aeroplane device, an aeroplane curved parabolically from front to rear, its curves, in successive sections from center to ends, decreasing in inclination to the path of travel, and a horizontal tail-surface approximate to the rear of said aeroplane, with means for vertically swinging said tail-surface.

38. In an aeroplane device, an aeroplane curved parabolically from front to rear, its curves, in successive sections from center to ends, decreasing in inclination to the path of travel, a horizontal tail-surface approximate to the rear of said aeroplane, with means for vertically swinging said tail-surface, and a fin-surface secured perpendicularly to the tail-surface.

39. In an aeroplane device, an aeroplane curved parabolically from front to rear, its curves, in successive sections from center to ends, decreasing in inclination to the path of travel, a horizontal tail-surface approximate to the rear of said aeroplane, with means for vertically swinging said tail-surface, and a fin-surface secured perpendicularly to the tail-surface and extending both above and below said surface.

40. In an aeroplane device, an aeroplane curved parabolically from front to rear, its curves in successive sections from center to ends decreasing in inclination to the path of travel, and its sections near the ends being

less sharply curved at their forward ends than the forward ends of sections nearer the center, and a horizontal tail-surface approximate to the rear of said aeroplane, with means for vertically swinging said tail-surface.

41. In an aeroplane device, an aeroplane curved parabolically from front to rear, its curves in successive sections from center to ends decreasing in inclination to the path of travel, and its sections near the ends being less sharply curved at their forward ends than the forward ends of sections nearer the center, a horizontal tail-surface approximate to the rear of said aeroplane, with means for vertically swinging said tail-surface, and a fin-surface secured perpendicularly to said tail-surface.

42. In an aeroplane device, an aeroplane curved parabolically from front to rear, its curves, in successive sections, from center to ends, decreasing in inclination to the path of travel, with means for changing the surface of said aeroplane, and a tail-surface approximate to the rear of said aeroplane, with means for vertically swinging said tail-surface.

43. In an aeroplane device, an aeroplane curved parabolically from front to rear, its curves in successive sections from center to ends decreasing in inclination to the path of travel and its sections near the ends being less sharply curved at their forward ends than the forward ends of sections nearer the center, with means for changing the surface of said aeroplane, and a tail-surface approximate to the rear end of said aeroplane, with means for vertically swinging said tail-surface.

44. In an aeroplane device, an aeroplane curved parabolically from front to rear, its curves in successive sections from center to ends decreasing in inclination to the path of travel, and its sections near the ends being less sharply curved at their forward ends than the forward ends of sections nearer the center, with means for changing the surface of said aeroplane, a tail-surface approximate to the rear end of said aeroplane, with means for vertically swinging said tail-surface, and a fin-surface secured perpendicularly to the tail-surface.

45. An aeroplane device, comprising plural aeroplanes, one in advance of another, with means for changing the surface of each, and means for varying the angle of one relatively to another, each of said aeroplanes being curved parabolically from front to rear, its curves in successive sections from center to ends decreasing in inclination to the path of travel, and its sections near the ends being less sharply curved at their forward ends than the forward ends of sections nearer the center, a horizontal tail-surface approximate to the rear portion of the last aeroplane, and means for vertically swinging said tail-surface.

46. An aeroplane device, comprising plural aeroplanes, one in advance of another, with means for changing the surface of each, and means for varying the angle of one relatively to another, each of said aeroplanes being curved parabolically from front to rear, its curves in successive sections from center to ends decreasing in inclination to the path of travel, and its sections near the ends being less sharply curved at their forward ends than the forward ends of sections nearer the center, a horizontal tail-surface approximate to the rear portion of the last aeroplane, means for vertically swinging said tail-surface, and a fin-surface secured perpendicularly to the tail-surface.

In witness whereof I have hereunto set my hand.

JOHN J. MONTGOMERY.

In presence of—

J. Compton,

D. B. Richards.

Claims of Chanute Patent.

No. 582,718. Filed December 7, 1895. Issued May 13, 1897. Expires May 13, 1914.

1. A soaring-machine having a rigid frame comprising a hoop A, plates K pivoted to said hoop, on upright pintles, wings L attached to said plates, and contractile members N lying I, the wings L having ribs l hinged in said plates, and the elastic cords N connecting the front ribs with the hoop A, substantially as described.

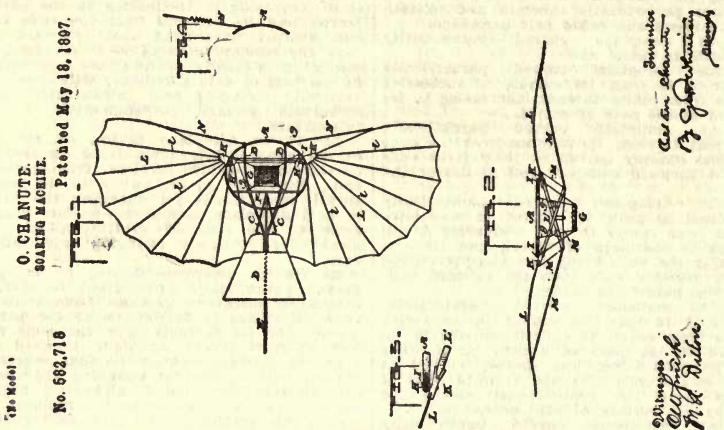

FIGURE 261.—Chanute Patent Drawing.

in the plane of the wings and attached at one end to the hoop and at the other end to the fronts of the wings, substantially as described.
 2. In a soaring-machine, the combination with the framework comprising the hoop A, of the plates K pivoted thereto on the pintles

In testimony whereof I affix my signature in presence of two witnesses,
 OCTAVE CHANUTE.

Witnesses:
 Charles J. Roney,
 Edw. Barrington.

Claims of Mouillard Patent.

No. 582,757. Filed September 24, 1892. Issued May 13, 1897. Expires May 13, 1914.

1. A soaring-machine consisting of an aeroplane composed of two wings, each hinged upon a vertical axis and capable of forward and backward movement only, substantially as described.
 2. A soaring-machine consisting of two wings, each hinged upon a vertical axis, an automatic regulating device controlling the angular position of the wings with the variation in speed, substantially as described.
 3. A soaring-machine consisting of two wings, each hinged upon a vertical axis, and a mechanical device attached to said wings for throwing forward the tips of the wings, substantially as described.
 4. A soaring-machine consisting of two wings, each hinged upon a vertical axis, and a spring attached to said wings, substantially as described.
 5. A soaring-machine consisting of two wings, each hinged upon a vertical axis, and a spring normally holding the tips of the wings in advance of said axis, substantially as described.
 6. A soaring-machine consisting of two wings, each hinged upon a vertical axis but in different approximately parallel planes, so that one can close partly over the other, substantially as described.
 7. A soaring-machine consisting of two wings, each hinged upon a vertical axis, and each having a tail portion adapted to close one over the other, substantially as described.

8. A soaring-machine consisting of two wings, each hinged upon a vertical axis, and adapted to close one over the other, and a mechanical device attached to said wings for positively closing them at will, substantially as described.
 9. A soaring-machine consisting of two wings, each hinged upon a vertical axis, and a cord attached to each wing and running through an eye in the other wing, for closing said wings together substantially as described.
 10. A soaring-machine consisting of two wings, each hinged upon a vertical axis, and provided with stop-cords to limit their angular movement, substantially as described.
 11. A soaring-machine consisting of two wings, each hinged upon a vertical axis, and having a portion movable out of the plane of the wing, substantially as described.
 12. A soaring-machine having wings adapted to move in horizontal planes, a portion of the fabric covering each wing being stiffened by flexible slats and having its rear edge free from the frame of the wing, and cords attached to said rear edge for pulling it downward, substantially as described.
 13. A soaring-machine consisting of two wings, each composed of a framework, a net spread under the framework, and a covering of fabric fastened below the net, substantially as described.
 14. A soaring-machine consisting of an ar

taiffical sternum adapted to be fastened to the body of the aviator and two wings, hinged to said sternum on an upright axis, substantially as described.

15. A cuirass or corset for an aviator consisting of a rigid breastplate provided with means for firmly attaching it to the body, and having attachments for receiving and sup-

ported to hold a spring, as G, substantially as described.

18. The combination with the rigid breastplate A carrying the hooks C, D of the wing, each having arms F provided with eyes f' to fit on the hooks, substantially as described.

19. The combination with the rigid breastplate A having the hooks C, D and the clamp

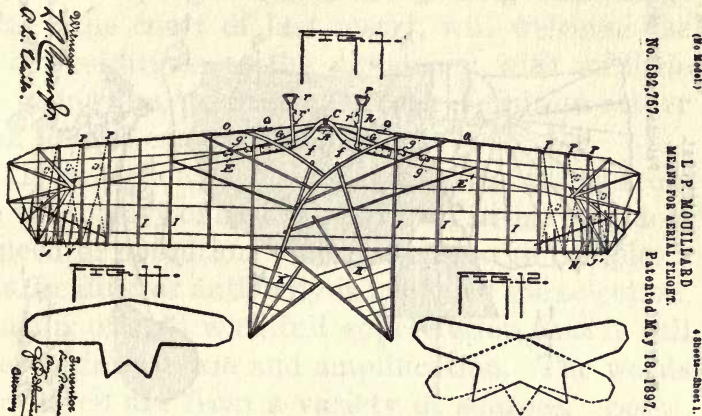

FIGURE 262.—Mouillard Patent Drawing.

porting an aeroplane, substantially as described.

16. A cuirass or corset for an aviator, consisting of a rigid breastplate provided with means for firmly attaching it to the body, and having hooks upon which a pair of wings may be hinged on a vertical axis, substantially as described.

17. The combination with the cuirass having a rigid breastplate A, of the hooks C, D, one above the other, and a clamp, as H, adapt-

ed, H, of the wings each having arms F hinged upon the hooks, and the flat steel spring G held at its middle by the clamp, and having its ends attached to the wings, substantially as described.

In testimony whereof I affix my signature in presence of two witnesses.

LOUIS PIERRE MOUILLARD.

Witnesses:

S. Nuripoy,
C. P. Lugold.

Claims of Lilienthal Patent.

No. 544,816. Filed February 28, 1894. Issued August 20, 1895. Expires August 20, 1912.

1. In a flying machine, the combination of two crossed carrying rods a, two wings vaulted upward, and strings or wires i extending from the ends of the carrying rods toward the peripheries of the wings, substantially as set forth.

2. In a flying machine, the combination of two crossed carrying rods a, two wings vaulted upward, strings or wires i connecting the two carrying rods with the wings, and a vertical fixed rudder substantially as set forth.

3. In a flying machine, the combination of a crossed frame, two wings connected therewith, strings or wires i, a vertical fixed rudder r and a horizontal tail q, adapted to turn upward automatically, substantially as set forth.

4. In a flying machine, the combination with a supporting frame, of a wing adapted to be folded together and having its ribs diverging from a common support, and suitably hinged thereto a string connecting the outer points of the ribs, and continuous fabric attached to a series of ribs, substantially as set forth.

5. In a flying machine, the combination with a supporting frame comprising a hoop, of a wing having its ribs diverging from a common support, a string connecting the outer

points of the ribs, a wire, as g, fastened to the first rib of the wing and attached to the hoop and fabric stretched over the ribs and such wire, substantially as set forth.

6. In a flying machine, the combination with a supporting frame, of a wing having its ribs diverging from a common support, fabric stretched over the ribs and wires, as i, extending from the ribs downward to the supporting frame for the purpose of adjusting thereby the tension of the ribs, substantially as set forth.

7. In a flying machine, the combination with a frame comprising a hoop and crossed bars connected therewith, of wings supported by said frame, substantially as set forth.

8. In a flying machine, a supporting frame for the wings comprising a hoop h, rods extending from it for supporting the operator and a tail and a rudder, and pockets as d for receiving the ends of the ribs of the wings, substantially as set forth.

9. In a flying machine the combination with a supporting frame, of wings with suitable ribs connected therewith, front tension wires g, and pockets d for receiving the inner ends of the ribs, the ribs being made capable of turning around their centers in such pock-

ets for the purpose of folding up such wings, substantially as set forth.

10. In a flying machine, the combination with a supporting frame, of wings, a fixed rudder and a pivoted tail adjusted to come to rest upon the rudder when swinging downward, substantially as set forth.

Signed at Berlin this 1st day of February, 1894.

OTTO LILIENTHAL.

Witnesses:

Herman Muller,
Reinhold Weidner.

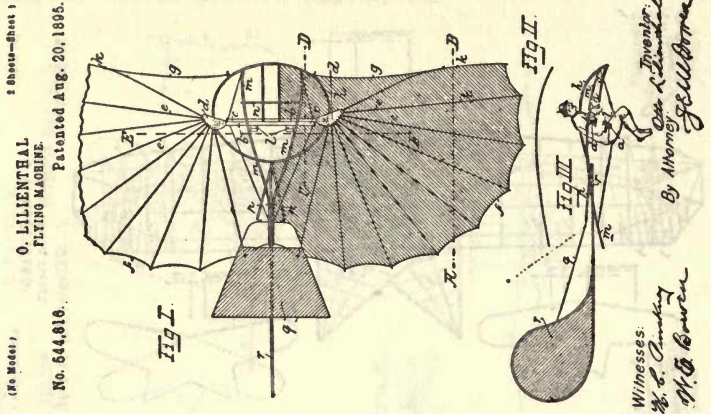

FIGURE 263.—Lilienthal Patent Drawing.

GLOSSARY OF AERONAUTICAL TERMS

The rapid and extensive recent development in aeronautics has given rise to a pressing need for proper technical terms wherewith to characterize the different elements of the new mechanisms without ambiguity or awkward circumlocution. In the English language this need has been met largely by borrowings from the French, supplemented by a number of new significances given to common words. Undoubtedly it is the superior richness of the French language in its technical nomenclatures, coupled with a quite characteristic fertility in the invention of timely words and phrases, that has enabled France thus to fasten so much of its aeronautical terminology upon us.

That there is anything objectionable in this situation, or in the often railed-at warping of modern meanings away from archaic significances,

is likely to be maintained only by extreme patriots or purists. The generality of readers and writers, knowing that the language of progressing mankind must itself progress, and recognizing that usage is here the court of last resort, will welcome the needed additions to the dictionary with as little ado as may be, preferring to seek definition rather than to give ear to denunciation.

In the following list are given the terms from the vocabulary of aeronautics most in use and most in need of definition. No pretension to completeness, finality, or authority is made for the selection, which is offered with full appreciation that it will meet both criticism and amplification. The words here given are from a variety of sources. Some, as has been suggested, are common words that new needs have invested with new meanings. Others are foreign or coined. A few have been frankly originated by the writer in the hope that they may meet needs not otherwise met. And many, of differing forms, are of synonymous meanings— included with the idea that only time can decide between them.

A

adjusting plane, *same as* ADJUSTING SURFACE.

adjusting surface. Commonly, a comparatively small surface, usually at the end of a wing tip, used to adjust lateral balance; preferably restricted to surfaces capable of variable adjustment but not of movement by controlling devices. *See* STABILIZER *and* WING TIP, *and compare* AILERON *and* BALANCING SURFACE.

advancing edge. The front edge of a sustaining or other surface. *See* FOLLOWING EDGE.

advancing surface. A surface that precedes another through the air, as in a double monoplane. *See* DOUBLE MONOPLANE *and* FOLLOWING SURFACE.

aerocurve, *n.* A proposed substitute for AEROPLANE, *which see*.

aerodrome, *n.* A substitute proposed by Langley for AEROPLANE, *which see*. Strictly applicable to a course rather than to a vehicle.

aerofoil, *n.* Another proposed substitute for AEROPLANE, *which see*.

aeroplane, *n.* A generic term applied in common use in all classes of sustaining surfaces; a misnomer to the extent that it is strictly applicable only to flat surfaces.

aileron, *â'tër-ôn*, *n.* A small hinged or separated wing tip or surface, capable of independent manipulation for the purpose of maintaining lateral balance. *See* BALANCING PLANE *and* BALANCING SURFACE, *and compare* ADJUSTING SURFACE, STABILIZER, *and* WING TIP.

- air speed, *n.*** The speed of an aerial vehicle through the air, as distinguished from its LAND SPEED, *which see*.
- alighting gear.** The under mechanism of an aeroplane, used to cushion its descent and to bring it to a stop as it reaches the ground. *See* RUNNER and STARTING DEVICE.
- angle of entry.** In a curved aeroplane surface, the angle made by a tangent to the advancing edge with the line of motion. *See* ANGLE OF INCIDENCE and ANGLE OF TRAIL.
- angle of incidence.** In a curved or a flat aeroplane surface, the angle made by the chord or by the surface with its line of travel. *See* ANGLE OF ENTRY and ANGLE OF TRAIL.
- angle of trail.** In a curved aeroplane surface, the angle of a tangent to the rear edge with the line of travel. *See* ANGLE OF ENTRY and ANGLE OF INCIDENCE.
- apteroid, ăp'tēr-oid, *a.*** A term coined by Lanchester to designate that type of wing which is short and broad, as opposed to PTERYGOID, *which see*.
- arc.** Any portion of a circle or other curve. *See* CHORD.
- arch.** A down curve given to the ends of a wing surface. *Compare* DIHEDRAL.
- aspect.** The top or plan view of an aeroplane surface. *See* ASPECT RATIO.
- aspect ratio.** The proportion of the length to the width of a wing or aeroplane surface. *See* ASPECT.
- aspiration, *n.*** The little-understood phenomena by which under certain circumstances an air current flowing against the edge of a properly curved wing or aeroplane surface, is said to draw such surface towards the current. *See* TANGENTIAL.
- attitude.** *Same as* ANGLE OF INCIDENCE, *which see*; also *see* FLYING ATTITUDE and GROUND ATTITUDE.
- automatic stability.** Applied to lateral or longitudinal stability maintained by the action of suitable elements on mechanisms independent of any control exercised by the operator; there is a tendency to restrict the term to such stability secured by automatic manipulation of controlling devices, rather than to systems in which balance is maintained by the use of fins or dihedral arrangements. *See* BALANCING SURFACE and STABILIZER.
- aviation, ă-vi-ă'shun.** Dynamic flight by means of HEAVIER-THAN-AIR mechanisms.
- aviator, ă'vi-ă-tēr.** The operator or pilot of a heavier-than-air flying machine.

B

- balance, *v.*** To maintain equilibrium by hand or automatic movement of balancing surfaces, as opposed to equilibrium maintained by stabilizing. *See* BALANCING SURFACE, and *compare* STABILIZE.
- balancing plane.** *Same as* BALANCING SURFACE.
- balancing surface.** Any surface capable of automatic or other manipulation for the purpose of steering, or of maintaining lateral or longitudinal balance. *See* ADJUSTING SURFACE, AILERON, ELEVATOR, and WING WARPING, and *compare* STABILIZING SURFACE and SUSTAINING SURFACE.
- beat.** Occasionally used to refer to the periodicity of revolving-blade or flapping-wing movements.
- biplane, bī'plān, *n.*** an aeroplane with two superposed main surfaces. *See* DOUBLE MONOPLANE, MONOPLANE, TRIPLANE, and MULTIPLANE.
- body.** The center portion of an aeroplane or other aerial vehicle, in which the motor, fuel tanks, passenger accommodation, etc., are placed. *See* FUSELAGE and NACELLE.
- brace, *n.*** In the structure of an aerial vehicle, a frame member in compression; preferably restricted to diagonal compression members, in contradistinction to STAY, *which see*, and therefore not the same thing as a STAY, *which see*.

C

- camber, *n.*** The maximum depth of curvature given to a surface as measured at right angles from the chord to the highest point of the surface.
- caster wheel.** In an alighting gear, a wheel mounted on a vertical pivot forward of its center of rotation, so that it automatically turns with changes in the course of the vehicle. *Compare* FIXED WHEEL.
- cell.** A boxlike unit, consisting of upper, lower, and side surfaces, as in a box kite; used to afford lateral stability by the action of its vertical surfaces and longitudinal stability by its horizontal surfaces.

- center of effort.** The point or axis along which the propulsive effort or thrust of one or more propellers is balanced.
- center of gravity.** The center of weight, about which the vehicle balances in all directions.
- center of lift.** The center or mean of one or more centers of pressure. *See* CENTER OF PRESSURE.
- center of pressure.** Really a line of pressure, along the under side of a wing or aeroplane surface, on either side of which the pressures are equal.
- center of resistance.** The point or axis against which the various forward pressures balance.
- center of thrust.** *Same as* CENTER OF EFFORT.
- chassis, shă-sê', n.** The under structure or running gear of a vehicle.
- chord.** A straight line drawn between the ends of the arc of a circle or other curve. *See* ARC.
- compound control.** A system of control in which two separate manipulations, as of a vertical or horizontal rudder, are effected by compound or two-directional movement of a single lever or steering wheel.
- compression side.** That side of a surface or propeller blade which acts against the air; usually the lower surface in the case of wings and aeroplanes. *Compare* RAREFACTION SURFACE.
- curtain, n.** *Same as* PANEL.

D

- deck, n.** A main aeroplane surface, used particularly with reference to BIPLANES and MULTIPLANES, *which see*.
- demountable, dê-mount'ăble, a.** Said of a mechanism designed with special provision for ready taking apart and reassembling.
- derrick, n.** A tower in which a falling weight is dropped to start an aeroplane.
- diagonal.** A diagonal brace or stay in a frame-work.
- dihedral, dî-hê'drăl, a.** Said of wing pairs inclined at an upward angle to each other. *Compare* ARCH.
- dirigible, dîr-ig'ible, a.** Steerable or navigable; applied to balloons.
- double monoplane, n.** A monoplane with two supporting surfaces, one in advance of the other. *See* ADVANCING SURFACE, FOLLOWING SURFACE, MONOPLANE, and MULTIPLANE.
- double rudder, n.** Any rudder in which there are two surfaces, usually similar in size and outline.
- double-surfaced, a.** Said of wings or aeroplanes with upper and lower surfaces, between which the ribs, wing bars, etc., are concealed. *Compare* SINGLE-SURFACED.
- down-wind, adv.** Movement in the direction of or with the wind. *Compare* UP-WIND.
- drift, n.** The aerodynamic resistance of an incorrect wing or aeroplane surface to forward movement, as distinguished from HEAD RESISTANCE and SKIN FRICTION, *which see*. *Compare* LIFT.
- droop, n.** *Same as* ARCH.

E

- elevator, n.** A term that has come into general use to describe horizontally placed rudders for steering in the vertical direction.
- ellipse.** One of the conic sections, certain portions of which are closely related to formation and development of correct wing sections. *See* PARABOLA and HYPERBOLA.
- entry, n.** A term that refers generally to the whole form, angle of entry, angle of incidence, etc., of an aeroplane or wing surface moving through the air. *See* ANGLE OF ENTRY, ANGLE OF INCIDENCE, WING SECTION.
- equivalent head area.** For purposes of calculation, an area of unbroken flat surface having a head resistance equivalent to the total of that of the various struts, bars, braces, stays, etc., of an aerial vehicle. *See* PROJECTED AREA.

F

- feathering, a.** Said of surfaces moved in such manner that in one direction they pass edgewise and in the other flatwise through the air.
- fin, n.** A single fixed vertical surface, not capable of movement out of its normal plane. *See* STABILIZING SURFACE.

- fish section, n.** A term applied to cross sections roughly resembling the body of a fish, blunt in front and more finely tapered towards the rear; a form that opposes a minimum resistance to movement through the air.
- fixed wheel.** In an alighting gear, a wheel not capable of being turned out of its normal plane of rotation. *See* CASTER WHEEL.
- flapping flight, n.** Flight by means of more or less rapidly reciprocating surface. *See* HELICOPTER, ORNITHOPTER, and SOARING FLIGHT.
- flexible propeller, n.** A propeller consisting of fabric more or less loosely mounted on a framework, so that it can adapt its form to the air pressures.
- flying attitude, n.** The angle of incidence of a wing or aeroplane surface in flight, as opposed to its angle when the machine is resting on a horizontal surface. *Compare* GROUND ATTITUDE.
- flying angle.** *Same as* FLYING ATTITUDE.
- following edge.** The rear edge of a wing or aeroplane surface. *Compare* ADVANCING EDGE.
- following surface.** A sustaining surface that is preceded by another, usually similar. *Compare* ADVANCING SURFACE.
- footpound, n.** The amount of energy required to raise one pound one foot; not involving the element of time. *See* HORSEPOWER.
- forced pressure.** An increase in the pressure of air adjacent to a surface that acts upon it. *Compare* FORCED VACUUM.
- forced vacuum.** A lowering in the pressure of air adjacent to the surface that acts upon it. *Compare* FORCED PRESSURE.
- fore-and-aft stability.** *Same as* LONGITUDINAL STABILITY.
- fuselage, fū'sēl-āj, n.** The framework of an aerial vehicle; preferably restricted to aeroplane frameworks.

G

- gap, n.** The distance between two adjacent surfaces in a biplane or multiplane.
- gliding, n.** Flying down a slant of air without power.
- gliding angle, n.** The angle at which gliding descent is made; usually the flattest angle at which a machine is capable of descending. *Compare* RISING ANGLE.
- gliding speed, n.** The speed at which an aerial vehicle glides at its flattest angle of descent. *See* GLIDING ANGLE.
- ground attitude.** The angle of incidence of an aeroplane surface with the machine standing on the ground, as opposed to its angle when the machine is in flight. *Compare* FLYING ATTITUDE.
- guy, n.** A wire or cord connecting with a more or less remote element of the mechanisms of a flying vehicle; preferably restricted to such wires and cords as constitute parts of the controlling system.
- gyroscope, jī'rō-skōp, n.** *See* GYROSCOPIC EFFECT.
- gyroscopic effect.** The property of any rotating mass whereby it tends to maintain its plane of rotation against disturbing forces.

H

- hangar, hāng'ār, n.** A shed for housing balloons or aeroplanes, generally the latter.
- head resistance.** The resistance of a surface to movement through the air; closely proportionate to its projected area. *See* DRIFT and PROJECTED AREA, and *compare* SKIN FRICTION.
- heavier-than-air, a.** Applied to dynamic flying machines weighing more than the air they displace. *Compare* LIGHTER-THAN-AIR.
- height, n.** Specifically, the maximum vertical dimension of an aerial vehicle.
- helicopter, n.** A dynamic flying machine, of the heavier-than-air type, in which sustentation is provided by the effect of screws or propellers rotating on vertical axes.
- horizontal, n.** A term suggested for a level plane through a flying machine when it is in flight, as opposed to a similar level taken when the machine is standing on a horizontal surface.
- horizontal rudder, n.** A horizontally placed rudder for steering in vertical directions. *Compare* VERTICAL RUDDER.
- horsepower, n.** A rate of work equivalent to the lifting of 33,000 footpounds a minute. *See* FOOTPOUND.

hovering, a. Said of flying in which practically a fixed position in the air is maintained.

hyperbola. One of the conic sections, believed by Lillienthal to be the correct form for a wing section. *See* ELLIPSE *and* PARABOLA.

K

keel. A longitudinally placed under-framing for stiffening the structure of a flying machine; chiefly employed in the design of elongated dirigible balloons.

L

lattice girder, n. A stiff and light structural element so named because of the resemblance of its criss-crossed members to lattice work.

lateral stability, n. Stability in the lateral or side-to-side direction. *Compare* LONGITUDINAL STABILITY.

land speed. The speed of an aerial vehicle over the land as distinguished from its AIR SPEED, *which see*.

landing area. A special surface upon which flying machines can alight with minimum risk of injury from obstructions. *See* STARTING AREA.

landing skate. *Same as* RUNNER.

leading edge. *Same as* ADVANCING EDGE.

leeway, n. Movement at right angles to a correct or desired course caused not by errors in steering, but by lateral drift of the whole body of the atmosphere.

lift, n. The sustaining effect, expressed in units of weight, of an aeroplane or wing surface; usually compared with DRIFT, *which see*.

lighter-than-air, a. Applied to an airship weighing less than the air it displaces. *Compare* HEAVIER-THAN-AIR.

longitudinal stability. Stability in the longitudinal or fore-and-aft direction. *Compare* LATERAL STABILITY.

M

main deck. *Same as* MAIN PLANE, *which see*.

main plane. Usually the largest or lowest supporting surface of a multi-surfaced aeroplane.

main landing wheels. In an alighting gear, the wheels that take the chief shock in landing.

mast, n. A spar or strut used for the attachment of wire or other stays to stiffen wings or other parts of a structure.

monoplane, n. An aeroplane with one or more main surfaces in the same horizontal plane. *See* DOUBLE MONOPLANE, *and compare* BIPLANE, MULTIPLANE, *and* TRIPLANE.

multiplane, n. An aeroplane with two or more superposed or otherwise arranged main surfaces; often, and perhaps preferably, applied to aeroplanes having three or more main surfaces. *See* BIPLANE, DOUBLE MONOPLANE, MONOPLANE, *and* TRIPLANE.

N

nacelle, nā-sēl', n. The framework or body of an aerial vehicle, preferably restricted to dirigible balloons. *See* FUSELAGE.

negative angle of incidence, n. An angle of incidence below the line of travel; capable, despite a common impression to the contrary, of affording considerable sustentation with correctly curved wing surfaces.

O

ornithopter, n. A dynamic flying machine, of the heavier-than-air type, in which sustentation is provided by the effect of reciprocating wing surfaces. *See* FLAPPING FLIGHT, ORTHOGONAL FLIGHT, *and* AEROPLANE.

orthogonal, or-thog'ō-nāl, a. Flapping flight in which sustentation is produced by direct reaction of the air in a vertical direction, as opposed to sustentation secured by a feathering movement of the wings. *See* FLAPPING FLIGHT.

P

- panel, n.** A vertical surface in a box-kite-like structure.
- parabola, n.** One of the conic sections, which is, with certain proper modifications, the correct curve for the section of a wing surface; a parabola is practically an ellipse with its other focus at infinity. *See* ELLIPSE and HYPERBOLA.
- partition, n.** *Same as* PANEL.
- phugoid theory, fū'goid, n.** A theory advanced by Lanchester to the effect that all types of aeroplanes naturally fly in undulating paths with the undulations of an amplitude and a period determined by the form and size of the structure.
- pilot, n.** A widely preferred term for the operator of an aerial vehicle.
- pitch, n.** The amount of forward movement that would be made by a propeller in the course of one rotation were it to progress through a solid nut. *See* PROPELLER, STRAIGHT PITCH, and UNIFORM PITCH.
- plane, n.** Practically a flat surface, though "aeroplane" has come to mean curved surfaces as well. *See* AEROPLANE.
- polyplane, n.** *Same as* MULTIPLANE.
- port, n.** The left side of a vehicle. *Compare* STARBOARD.
- projected area, n.** The equivalent flat area of an irregular structure; the same as the area of the shadow of such a structure cast by parallel rays on a plain surface. *See* EQUIVALENT HEAD AREA.
- propeller reaction.** The tendency of a single or unneutralized propeller revolving in one direction to revolve the vehicle to which it is attached in the other direction.
- pterygoid, a.** A term coined by Lanchester to designate that type of wing which is long and narrow, as opposed to APTEROID, *which see*.
- pylon, n.** *Same as* DERRICK.
- radial spoke, n.** In a wire vehicle wheel, a spoke extending radially from the hub to the rim. *Compare* TANGENT SPOKE.

R

- rarefaction side, n.** That side of a surface or propeller blade, opposite that which acts against the air; usually the upper surface in the case of wings and aeroplanes. *See* COMPRESSION SIDE.
- reactive stratum, n.** The compressed stratum of air flowing beneath an aeroplane surface or behind a propeller blade.
- rib, n.** An aeroplane member parallel to and used to maintain the correct form of the wing sections. *Compare* STIFFENER and WING BAR.
- rising angle, n.** The angle at which an aeroplane ascends in the air; usually the steepest angle at which it is capable of ascending. *Compare* GLIDING ANGLE.
- rudder, n.** A vertical or horizontal surface for steering in a horizontal or vertical direction. *See* HORIZONTAL RUDDER and VERTICAL RUDDER.
- runner, n.** Used in some alighting gears in preference to wheels because of the better action upon contact with the ground.

S

- screw, n.** *Same as* PROPELLER.
- semichord, n.** The part of a chord on either side of the highest point of the curve; not necessarily an exact half of the chord. *See* CHORD.
- single-surfaced, a.** Said of wings or aeroplanes with single surfaces, above or below which the ribs and wing bars are placed. *Compare* DOUBLE-SURFACED.
- skid, n.** *Same as* RUNNER.
- skin friction, n.** The friction of the air against the surfaces of an aerial vehicle.
- slip, n.** The amount of distance lost in the travel of a propeller, estimated by comparison of the distance actually travelled in a given number of turns with the distance that theoretically should be travelled as figured from the PITCH. *See* PITCH.
- soaring flight, n.** The flight of certain large birds without wing flapping, differing from gliding in that it commonly involves upward movement apparently in defiance of the laws of force and motion, though some, without well-established reason, suppose it to be accomplished by taking

advantage of rising air currents, internal air movements, etc. Its solution and imitation constitute one of the problems of aerial navigation.

- spar, n.** A term in more or less common use to describe struts, masts, braces, etc.
- stabilize, v.** To maintain equilibrium by the action of surfaces rather than by the manipulation of devices.
- stabilizer, n.** An anglicised form of the French "*stabilisator*." Any surface for automatically maintaining lateral or longitudinal balance. *See* AUTOMATIC STABILITY, FIN, LATERAL BALANCE, and LONGITUDINAL BALANCE.
- stabilizing surface, n.** Any surface placed in a vertical or other position, primarily for the purpose of maintaining equilibrium. *See* CELL, DIHEDRAL, FIN, LATERAL STABILITY, and PANEL, and compare BALANCING SURFACE and SUSTAINING SURFACE.
- stable equilibrium, n.** said of machines in which any tendency to tip over automatically corrects itself without the use of automatic balancing devices. *See* FIN.
- starboard, n.** The right side of a vehicle. *Compare* PORT.
- starting area.** A special surface from which flying machines can be launched either with or without starting devices. *See* LANDING AREA and STARTING DEVICE.
- starting device.** Any device for launching aerial vehicles. *See* DERRICK, STARTING IMPULSE, STARTING RAIL, and STARTING TRUCK.
- starting impulse.** The initial thrust required for starting aeroplanes; secured either by the propeller thrust or other means within the vehicle itself, or by special extraneous appliances. *See* DERRICK, STARTING DEVICE, STARTING RAIL.
- starting rail, n.** A rail on which an aeroplane is run in starting. *See* STARTING DEVICE, STARTING IMPULSE, and STARTING TRUCK.
- starting truck, n.** A small truck upon which an aeroplane is mounted while there is imparted to it the initial impulse. *See* STARTING DEVICE, STARTING IMPULSE, and STARTING RAIL.
- stay, n.** In the structure of an aerial vehicle, a frame member of wire or other material. *See* BRACE.
- stiffener, n.** A straight bar used to stiffen a flat surface, in contradistinction to a rib, which maintains the curvature of a curved surface. *Compare* RIB.
- straight pitch, n.** In an aerial propeller, a uniform angle of blade surface from hub to tip, so that the different portions of the blade do not advance through the air at the same speeds. *Compare* UNIFORM PITCH.
- strainer, n.** *Same as* TURNBUCKLE.
- strut, n.** A compression member in a structure; particularly applied to vertical members separating the sustaining surface of biplanes and multiplanes. *See* BRACE and SPAR.
- strut socket.** A metal or other socket or corner piece for joining struts and other frame members.
- supplementary surface, n.** A comparatively small surface used in conjunction with larger surfaces for some special purpose, as the maintenance of equilibrium, for steering, etc. *See* AILERON, FIN, and RUDDER.
- sustaining surface, n.** Any surface placed in a horizontal, or approximately horizontal position, primarily for the purpose of affording sustentation. *See* AEROPLANE and compare BALANCING SURFACE and STABILIZING SURFACE.

T

- tail, n.** A rear element of an aeroplane adapted to improve its stability and often affording a place for the attachment of vertical and horizontal rudders, stabilizing devices, etc. *See* CELL, ELEVATOR, and RUDDER.
- tail wheel, n.** A wheel mounted under the tail of an aeroplane to support it on the ground. *See* CASTER WHEEL and RUNNING GEAR.
- tangential, a.** Applied to the forward inclination of the sustaining force with certain surfaces at certain angles, so that the surface tends to move into the wind. *See* ASPIRATION and DRIFT, and compare LIFT.
- tangent spoke.** In a wire vehicle wheel, a spoke extending on a tangent from the hub circle to the rim, this construction affording a wheel adapted to transmission of power. *Compare* RADIAL SPOKE.
- tie, n.** A wire or other tension member connecting two points in a structure. *See* STAY.

tightener. Any device for tightening a stay wire, but preferably restricted to tighteners of types that do not involve cutting the wire. *Compare* TURNBUCKLE.

tractor screw. A propeller placed in front of a vehicle, so that it pulls instead of pushes it through the air.

traveling speed, n. Same as GLIDING SPEED, *which see*; also used to refer to the maximum speed of an aeroplane.

triplane, n. An aeroplane with three main surfaces. *Compare* BIPLANE, DOUBLE MONOPLANE, and MONOPLANE.

trochoidal, trō'koyd-äl, a. A term coined by Hargrave, a *trochoidal plane* being defined by him as "a flat surface, the center of which moves at a uniform speed in a circle, the plane being kept normal to the surface of a *trochoidal wave*, having a period equal to the time occupied by the center of the plane in completing one revolution."

turnbuckle. A device with a right and left-hand screw for tightening wire ties and stays. *Compare* TIGHTENER.

U

uniform pitch. In an aerial propeller a varying angle of blade surface from hub to tip, so that all portions of the blade tend to advance through the air at the same rate of speed. *See* PITCH and STRAIGHT PITCH.

up-wind, adv. Movement in a direction directly against the wind. *Compare* DOWN-WIND.

V

vertical rudder. A vertically-placed rudder for steering in horizontal directions. *Compare* HORIZONTAL RUDDER.

W

wake, n. The trail of disturbed air left by a moving aerial vehicle, invisible, but in a way resembling the wake of a ship in its effect upon other vehicles that pass into it. *See* WASH.

wash, n. Lateral oscillations of air sent out from the sides of an aerial vehicle; invisible as in the case of the foregoing except by their effect upon adjacent vehicles. *See* WAKE.

wing arc, n. The arc of movement of a flapping wing. *See* FLAPPING FLIGHT and ORNITHOPTER.

wing bar. A longitudinal strengthening member in a wing or aeroplane, running from tip to tip and crossed at right angles by the ribs. *See* RIBS.

wing girder, n. Same as wing bar, excepting that it usually implies a more elaborately built-up construction.

wing plan, n. The outline of a wing or aeroplane surface viewed from directly above or below.

wing section. The fore-and-aft curvature, to the path of movement, in the sections of a wing or aeroplane. *See* AEROPLANE, ELLIPSE, HYPERBOLA, and PARABOLA.

wing skid. A small runner under the tip of a wing to protect it from damage by coming in contact with the ground. *Compare* WING WHEEL.

wing tip. The extreme outer end of a wing, often made movable or capable of warping, to control lateral balance. *See* AILERON and WING WARPING.

wing warping. A system of maintaining lateral balance by differential twisting of wing tips, in such manner as to increase the sustentation on one side and decrease it on the other.

wing wheel. A small wheel under the tip of a wing to protect it from damage by coming in contact with the ground.

CHAPTER FIFTEEN

FLIGHT RECORDS

Much interest naturally attaches to the various records that have been made with flying machines, for which reason there is herein presented in tabu-

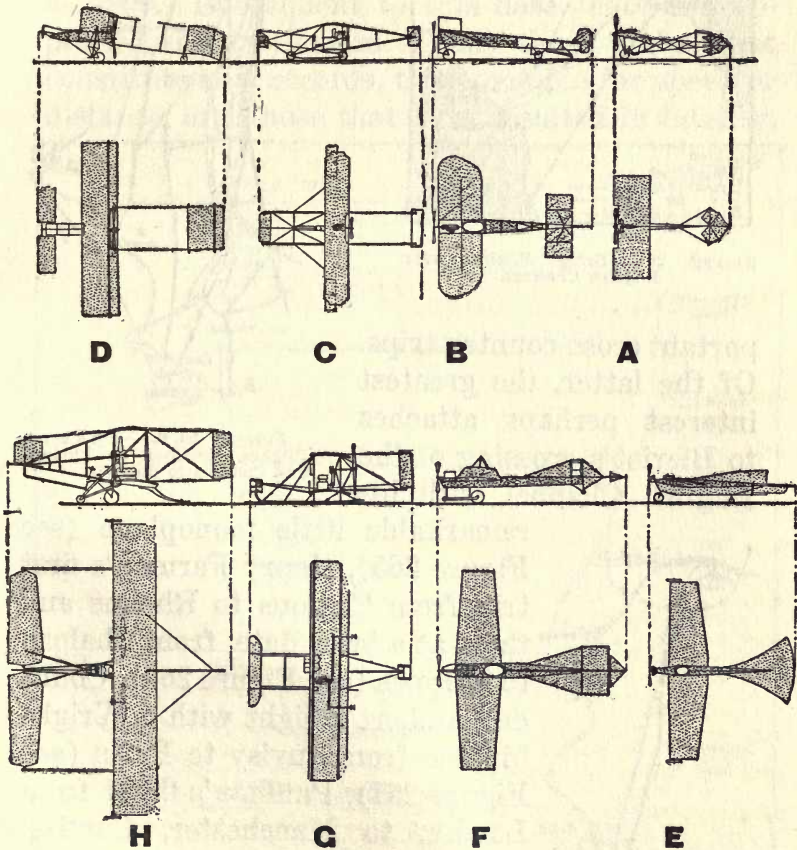

FIGURE 264.—Diagrammatic Comparisons of Modern Aeroplanes. *A*, Santos-Dumont Monoplane; *B*, Bleriot Monoplane; *C*, Curtiss Biplane; *D*, Voisin Biplane; *E*, R. E. P. Monoplane; *F*, Antoinette Monoplane; *G*, Wright Biplane; *H*, Cody Biplane.

lar form the most complete record yet published of such flights, together with maps of the more im-

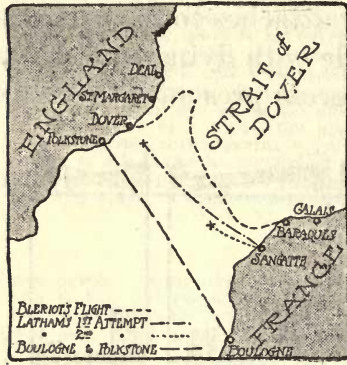

FIGURE 265.—Early Flights over English Channel.

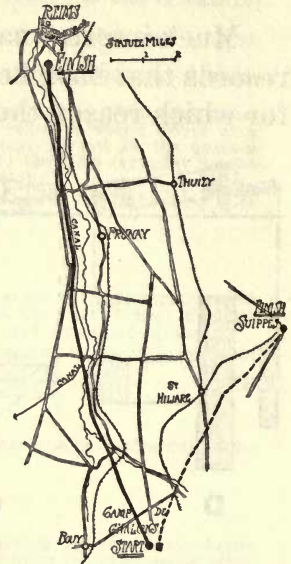

FIGURE 266.—Farman Flights, Chalons to Rheims, and Chalons to Suippes.

portant cross-country trips. Of the latter, the greatest interest perhaps attaches to Bleriot's crossing of the English Channel with his

remarkable little monoplane (see Figure 265), Henry Farman's first trip from Chalons to Rheims and then, at a later date, from Chalons to Suippes (see Figure 266); Count de Lambert's flight with a Wright biplane from Juvisy to Paris (see Figure 267), Paulhan's flight from London to Manchester, Curtiss' flight from Albany to New York, and Captain Roll's round-trip flight across the English Channel, Hamil-



FIGURE 267.

ton's flight from New York to Philadelphia and return, Vedrine's flights with the Morane mono-

plane in France, Renaux' flight to the summit of the Puy de Dome, and Prier's London-to-Paris flight.

In the tabular history that follows are given the full particulars of every flight of special importance or interest from the earliest times to the end of 1909. Subsequent to this date there are appended the particulars of only those flights that constitute new records, those notable for speed or distance, and those that have resulted in fatality.

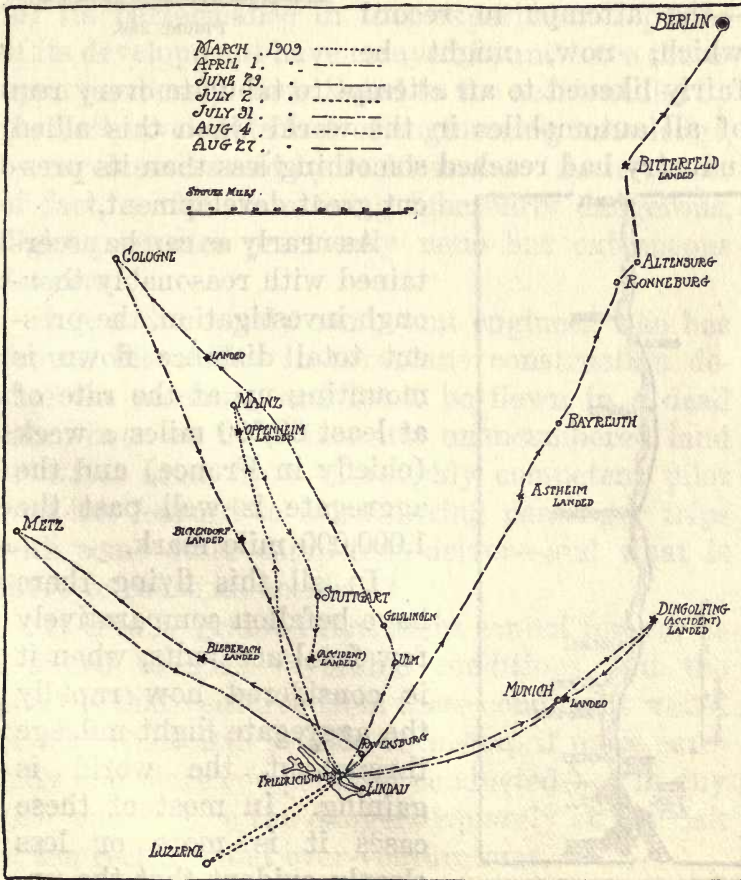

FIGURE 268.—Map Showing Principal Zeppelin Flights.

It was originally the author's intention to continue to chronicle every flight, however brief in duration, but at this writing it is the fact that aeronautical development has progressed too fast and far for detailed track to be kept of every minor flight—the attempt to record which, now, might be fairly likened to an attempt to tabulate every run of all automobiles in the world when this allied industry had reached something less than its present great development.

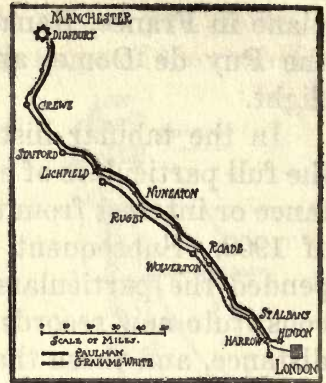

FIGURE 269.

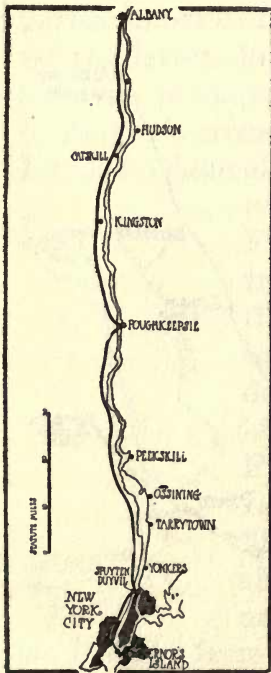

FIGURE 270.

As nearly as can be ascertained with reasonably thorough investigation, the present total distance flown is mounting up at the rate of at least 60,000 miles a week (chiefly in France) and the aggregate is well past the 1,000,000 mile mark.

In all this flying there have befallen comparatively few fatal accidents, when it is considered how rapidly the aggregate flight mileage throughout the world is gaining. In most of these cases it is more or less clearly evident that the un-

fortunate result was due to some preventable carelessness or recklessness rather than to any inherent danger inseparable from the reasonably judicious use of the new vehicles of the air.

From the standpoint of the supposed inherent dangers in aviation, an even better showing might be made by a careful analysis of the fatal accidents that have occurred. Indeed, the accomplishment of flight has become almost too easy—with the regrettable result that men wholly unequipped for its performance in this experimental period of its development have essayed it, and have thereupon needlessly contributed to the accident list by perfectly avoidable lack of engineering knowledge, by carelessness and by recklessness. As a matter of fact, so far from being inherently dangerous, flight possesses practically none but extraneous dangers.

Let a thoroughly competent engineer who has proved his ability in aeroplane construction design the machine, and let it be flown in a dead calm, over an unbroken and unencumbered land or water area, by a thoroughly competent pilot who has learned to drive during passenger trips with some other competent driver—and what is there to cause an accident?

It is to be granted that flight cannot forever be confined to such favorable conditions, but the point is that ventures from these conditions would be materially less prolific of mishap if more carefully and more competently conducted—or in any case would place the dangers squarely at the risk of the reckless and over-venturesome.

TABULAR HISTORY OF FLIGHTS

DATE.	PLACE.	MACHINE.	FASENERERS.	DISTANCE.	HRS. MIN.	SEC.	REMARKS.
11th Century.	Over Lake Trasimene.	Glider	Oliver of Malmesburg.	370 feet	From tower; fell and broke leg.
15th Century.	Perugia, Italy.	Glider	Gio Battista Dante.	800 feet	From tower; fell and broke leg.
1843	England	Stringfellow	Gio Battista Dante.	138 feet	Broke wing. Flown along with.
1866	Wenham	Glider	Mouillard	600 feet	First biplane. Started as kite.
1867	Trefuente, France	Glider	Le Bris	100 feet	Monoplane model.
1871	Paris, France	Glider	A. Penna	131 feet	0:00:11	Model.
1880	Australia	Hargrave	John J. Montgomery.	943 feet	Straightway.
Oct. 9, 1880	Chateau d'Armain.	"Hole"	Clement Ader	164 feet	Model.
1881	Australia	Hargrave	Otto Lilienthal	128 feet	Two thousand shorter glides.
1882	Germany	Glider	Percy Plicher	600 feet	Hovering in wind. Many shorter glides.
1883	Cardross, Scotland.	Glider	Wright brothers	520 feet	Capized.
1884	England	Multipians	Hiram Maxim	800 feet	Thirty-pound model.
July 31, 1884	Potomac River.	Langley	Otto Lilienthal	4,000 feet	Lilienthal killed.
May 6, 1886	England	Langley	Otto Lilienthal	1,000 feet	Two thousand glides on thirty different days.
Aug. 10, 1886	Dune Park, Indiana.	Glider	Octave Chanute, A. M. Heryng, and William Avery	600 feet	Attempted circle
1897	Satory, France	Multipiano	H. Langley	984 feet	Plicher killed.
Oct. 14, 1897	Satory, France	Avion	Clement Ader	600 feet	One thousand shorter glides.
Sept. 30, 1899	Xaverftoft, England.	Glider	Percy Plicher	900 feet	With power.
Dec. 19, 1903	Kitty Hawk, N. C.	Wright	Wright brothers	852 feet	Went in water.
Oct. 16, 1903	Potomac River.	Langley	Manly	40 feet	From balloon 800 feet high.
Mar. 18, 1905	Leonards, California.	Glider	Montgomery	From balloon 3,000 feet high.
Mar. 20, 1905	Leonards, California.	Glider	Montgomery	Many shorter glides.
April 28, 1905	Santa Clara, Cal.	Montgomery glider.	Daniel Maloney	8 miles	Maloney killed.
July 18, 1905	Santa Clara, Cal.	Montgomery glider.	Daniel Maloney	
Sept. 20, 1905	Dayton, Ohio.	Biplane	Wright	11.12 miles	0:18:00	
Sept. 20, 1905	Dayton, Ohio.	Biplane	Wright	12 miles	0:17:15	
Sept. 30, 1905	Dayton, Ohio.	Biplane	Wright	15.25 miles	0:35:05	
Oct. 3, 1905	Dayton, Ohio.	Biplane	Wright	20.75 miles	0:33:17	
Oct. 4, 1905	Dayton, Ohio.	Biplane	Wright	24.2 miles	0:38:03	
Oct. 5, 1905	Dayton, Ohio.	Biplane	Wright	Few feet	0:00:108	
Aug. 27, 1906	Bagatelle, France.	Biplane "No. 1"	Alberto Santos-Dumont.	160 feet	Without rear rudder.
Oct. 8, 1906	Isny, France.	Biplane "No. 1"	Alberto Santos-Dumont.	177 feet	
Oct. 24, 1906	Bagatelle, France.	Monoplane	Volsin	164 feet	
Nov. 13, 1906	Bagatelle, France.	Biplane "No. 1"	Alberto Santos-Dumont.	197 feet	
Nov. 13, 1906	Bagatelle, France.	Biplane "No. 1"	Alberto Santos-Dumont.	271 feet	
Nov. 13, 1906	Bagatelle, France.	Biplane "No. 1"	Alberto Santos-Dumont.	722 feet	0:00:21 1/4	
Nov. 13, 1906	Bagatelle, France.	Monoplane	Alberto Santos-Dumont.	122 feet	
Nov. 13, 1906	Bagatelle, France.	Monoplane	Alberto Santos-Dumont.	33 feet	
Nov. 16, 1907	Bagatelle, France.	Volsin	Leon Delagrang	658 feet	Seven unsuccessful machines built before this.
Mar. 30, 1907	Bagatelle, France.	Volsin	Henry Farman	100 feet	
April 6, 1907	Bagatelle, France.	Monoplane	Louis Bleriot	100 feet	
July 11, 1907	Bagatelle, France.	Monoplane	Louis Bleriot	493 feet	
July 25, 1907	Isny, France.	Monoplane	Louis Bleriot	469 feet	
Aug. 6, 1907	Isny, France.	Monoplane	Louis Bleriot	610 feet	
Sept. 17, 1907	Isny, France.	Monoplane	Louis Bleriot	935 feet	
Oct. 15, 1907	Isny, France.	Volsin	Henry Farman	Very short	
Oct. 25, 1907	Buc, France.	Monoplane	Robert Esnault Pelterie	1,190 feet	
Oct. 25, 1907	Buc, France.	Monoplane	Robert Esnault Pelterie	1,522 feet	
Oct. 26, 1907	Isny, France.	Volsin	Henry Farman	2,530 feet	First turn.
Oct. 26, 1907	Isny, France.	Volsin	Henry Farman	492 feet	With rear rudders.
Oct. 27, 1907	Buc, France.	Monoplane	Robert Esnault Pelterie	196 feet	
Nov. 15, 1907	Isny, France.	Monoplane "No. 2"	Count de Voisins	
Nov. 15, 1907	Isny, France.	Monoplane "No. 2"	Count de Voisins	
Nov. 31, 1907	Bagatelle, France.	Biplane "No. 2"	Alberto Santos-Dumont.	478 feet	

TABULAR HISTORY OF FLIGHTS—Continued

Date	Location	Country	Plane	Pilot	Altitude	Notes
Dec. 1, 1907	Banck, Nova Scotia	U.S.	Selfridge	T. E. Selfridge	656 feet	
Dec. 1, 1907	Issy, France	France	Monoplane	Louis Blériot	1,978 feet	
Dec. 6, 1907	Issy, France	France	Monoplane	Louis Blériot	1,670 feet	
Dec. 17, 1907	Issy, France	France	Monoplane	H. de Fischeff	4,921 feet	
Dec. 31, 1907	Issy, France	France	Volsin	Henry Farman	26 feet	
Jan. 18, 1908	Issy, France	France	Volsin	Henry Farman	4,921 feet	
Feb. 12, 1908	Bagatelle, France	France	Monoplane	Gastambide-Mengin	492 feet	
Mar. 12, 1908	Hammondsport, N. Y.	U.S.	"June Bug"	J. A. D. McCurdy	318 feet	
Mar. 20, 1908	Issy, France	France	Volsin	Leon Delagrangé	1,978 feet	
Mar. 21, 1908	Issy, France	France	Volsin	Leon Delagrangé	4,921 feet	
Mar. 21, 1908	Issy, France	France	Volsin	Henry Farman	1,225 miles	
Mar. 24, 1908	Issy, France	France	Volsin	Leon Delagrangé	4,921 feet	
Mar. 29, 1908	Chenit, France	France	Volsin	Farman and Delagrangé	453 feet	
Apr. 10, 1908	Issy, France	France	Volsin	Leon Delagrangé	315 miles	
Apr. 11, 1908	Issy, France	France	Volsin	Leon Delagrangé	810 miles	
May 27, 1908	Rome, Italy	Italy	Volsin	Leon Delagrangé	6,592 miles	
May 30, 1908	Rome, Italy	Italy	Volsin	Leon Delagrangé	7,776 miles	
June 2, 1908	Chenit, France	France	Volsin	Henry Farman	3,980 feet	
June 17, 1908	Luc, France	France	Volsin	Henry Farman	3,980 feet	
June 22, 1908	Milan, Italy	Italy	Volsin	Luigi Bleriot-Falferle	10,863 miles	
June 29, 1908	Issy, France	France	Monoplane	Louis Blériot	2,286 miles	
July 4, 1908	Hammondsport, N. Y.	U.S.	"June Bug"	J. A. D. McCurdy	3,420 feet	
July 4, 1908	Issy, France	France	Monoplane	Louis Blériot	8,728 miles	
July 6, 1908	Ghent, France	France	Volsin	Henry Farman	0:08:47	
July 6, 1908	Turin, Italy	Italy	Volsin	Louis Delagrangé and Mme. Therese Lettier	12.24 miles	
July 8, 1908	Turin, Italy	Italy	Volsin	Louis Delagrangé	656 feet	
July 9, 1908	Huanderes, France	France	Biplane	Wilbur Wright	0:01:45	
Aug. 12, 1908	Huanderes, France	France	Biplane	Wilbur Wright	0:03:43	
Aug. 12, 1908	Huanderes, France	France	Biplane	Wilbur Wright	0:06:56	
Aug. 13, 1908	Issy, France	France	Biplane	Captain Ferber	0:08:18%	
Aug. 18, 1908	Huanderes, France	France	Biplane	Wilbur Wright	840 feet	
Aug. 19, 1908	Issy, France	France	Biplane	Captain Ferber	1,640 feet	
Aug. 29, 1908	Issy, France	France	Biplane	Captain Ferber	1 mile	
Sept. 5, 1908	Anvours, France	France	Biplane	Wilbur Wright	0:01:30	
Sept. 6, 1908	Anvours, France	France	Biplane	Wilbur Wright	0:10:48%	
Sept. 6, 1908	Issy, France	France	Volsin	Leon Delagrangé	0:29:53%	
Sept. 9, 1908	Ft. Myer, Va.	U.S.	Biplane	Orville Wright	0:37:31	
Sept. 9, 1908	Ft. Myer, Va.	U.S.	Biplane	Whille Wright	1:02:30	
Sept. 10, 1908	Ft. Myer, Va.	U.S.	Biplane	Whille Wright	1:04:57	
Sept. 11, 1908	Ft. Myer, Va.	U.S.	Biplane	Orville Wright	1:10:50	
Sept. 12, 1908	Ft. Myer, Va.	U.S.	Biplane	Orville Wright	1:15:20	
Sept. 14, 1908	Issy, France	France	Biplane	Uberto Santos-Dumont	0:09:00	
Sept. 16, 1908	Anvours, France	France	Biplane	Wilbur Wright	0:08:00	
Sept. 17, 1908	Issy, France	France	Volsin	Leon Delagrangé	0:30:27%	
Sept. 21, 1908	Anvours, France	France	Biplane	Wilbur Wright	1:31:25%	
Sept. 22, 1908	Anvours, France	France	Biplane	Wilbur Wright	1:33:20%	
Sept. 24, 1908	Anvours, France	France	Biplane	Wilbur Wright	0:54:35%	
Sept. 25, 1908	Anvours, France	France	Biplane	Wilbur Wright	0:09:01%	
Sept. 25, 1908	Anvours, France	France	Biplane	Wilbur Wright	0:11:35%	
Sept. 25, 1908	Chalons, France	France	Volsin	Henry Farman	24,232 miles	
Sept. 29, 1908	Chalons, France	France	Volsin	Henry Farman	24,000 miles	
Oct. 1, 1908	Chalons, France	France	Volsin	Henry Farman	24,544 miles	
Oct. 2, 1908	Chalons, France	France	Volsin	Henry Farman	24,654 miles	
Oct. 3, 1908	Chalons, France	France	Biplane	Wilbur Wright and Franz Sichel	0:55:37%	

Propellers had just been lengthened which made them interfere with rudder wires, wrecking machine and fatally injuring Selfridge.
Averaged 25 feet high
Eighteen-mile wind.

TABULAR HISTORY OF FLIGHTS—Continued

Oct. 6, 1908	Chalons, France	Biplane	Wilbur Wright and Leon	0:04:00	Boilee's weight, 238 pounds.
Oct. 7, 1908	Chalons, France	Biplane	Wilbur Wright and Arnold	1:04:26 1/2	
Oct. 7, 1908	Chalons, France	Biplane	Fordeyce Wright and Mrs.	0:02:03	
Oct. 10, 1908	Chalons, France	Biplane	Hart O. Berg	
Oct. 21, 1908	Toury, France	Monoplane	Louis Bleriot	Estimated total of Wright's flights in France to this date, 13 hrs., 49 min., carrying 13 persons, total of 431 miles without accident.
Oct. 26, 1908	Brussels, Belgium	Triplane	Baron de Caters	0:04:00	Speed record.
Oct. 26, 1908	Chalons, France	Voisin	Henry Farman	0:17:50	Fifty-five miles an hour, with wind.
Oct. 30, 1908	Bouy to Rheims	Voisin	Henry Farman	Eighty-two feet high.
Oct. 31, 1908	Chalons, France	Voisin	Henry Farman	Cross country: three landings: 43.7 miles an hour.
Oct. 31, 1908	Toury, France	Monoplane	Louis Bleriot	0:11:00	
Oct. 31, 1908	Toury to Artenay	Monoplane	Louis Bleriot	
Nov. 21, 1908	Germany	Voisin	Kennes Gossner	
Dec. 1, 1908	Germany	Voisin	M. Ziepel	
Dec. 1, 1908	Germany	Voisin	J. T. C. Moore-Brabazon	
Dec. 9, 1908	Germany	Voisin	M. Ziepel	0:54:53 1/2	
Dec. 18, 1908	LeMans, France	Biplane	Wilbur Wright	
Dec. 18, 1908	LeMans, France	Biplane	Baron de Caters	
Dec. 26, 1908	Brecht, France	Triplane	Henry Farman	
Dec. 28, 1908	Issy, France	"Antoinette IV"	M. Weileringer	"All directions."
Dec. 28, 1908	Issy, France	Biplane	Wilbur Wright	Circle, at 49 miles an hour.
Dec. 28, 1908	Avouray, France	Biplane	M. Weileringer	Thirty to 35 miles per hour.
Dec. 28, 1908	Avouray, France	Biplane	Wilbur Wright	Several flights.
Dec. 31, 1908	Avouray, France	Biplane	M. Weileringer	Officially only 76.5 miles.
Jan. 1, 1909	Farnborough, England	Biplane	S. F. Cody	2:20:23	
Jan. 2, 1909	Issy, France	"Antoinette IV"	M. Gastambide	
Jan. 6, 1909	Issy, France	"Antoinette IV"	M. Weileringer	
Jan. 9, 1909	Chalons, France	Army Biplane	S. F. Cody	First passenger.
Jan. 16, 1909	Chalons, France	Voisin	J. T. C. Moore-Brabazon	Broke wing.
Jan. 16, 1909	Chalons, France	Voisin	J. T. C. Moore-Brabazon	Ten feet high.
Jan. 18, 1909	Issy, France	Voisin	J. T. C. Moore-Brabazon	Three descents
Jan. 18, 1909	Issy, France	"Bleriot XI"	Louis Bleriot	In circle
Jan. 18, 1909	St. Martin de Crau	M. Zetopp	Five flights.
Jan. 19, 1909	Berlin	M. Zetopp	First flight of this model.
Jan. 19, 1909	Berlin	M. Zetopp	Broke elevator.
Jan. 23, 1909	Chalons, France	"Bleriot XI"	Louis Bleriot	
Jan. 28, 1909	Berlin	Voisin	J. T. C. Moore-Brabazon	
Feb. 1, 1909	Bennwillers, France	Triplane	Borgnis	
Feb. 1, 1909	Berlin	Voisin	Wilbur Wright	
Feb. 1, 1909	Berlin	Biplane	Wilbur Wright and Paul	
Feb. 14, 1909	Mourmelon le Grand	Voisin	M. Tussauder	
Feb. 14, 1909	Mourmelon le Grand	Voisin	M. Legagneux	1.24 mile
Feb. 14, 1909	Mourmelon le Grand	Voisin	M. Legagneux	3.10 miles
Feb. 14, 1909	Mourmelon le Grand	Voisin	Henry Farman and passenger	6.21 miles
Feb. 15, 1909	Pat, France	Biplane	Wilbur Wright and Katherine	3.10 miles
Feb. 15, 1909	Pat, France	Biplane	Wilbur Wright	0:07:00	
Feb. 16, 1909	Issy, France	Biplane	Wilbur Wright and Count	
Feb. 16, 1909	Chalons, France	"Bleriot XI"	de Lambert	2.48 miles
Feb. 20, 1909	Pat, France	"Antoinette V"	Louis Bleriot	4.893 feet
Feb. 20, 1909	Font Long, France	Biplane	Wilbur Wright	3,900 feet
Feb. 20, 1909	Font Long, France	Biplane	Wilbur Wright and Count	0:28:00	Partly cross-country.
Feb. 20, 1909	Font Long, France	Biplane	de Lambert	0:20:00	

TABULAR HISTORY OF FLIGHTS—Continued

Feb. 22, 1909 Pau, France Biplane Wilbur Wright and M. Barbot	0:05:00	Ninety feet high. Twelve-mile wind.
Feb. 22, 1909 Baddeck, Nova Scotia Army biplane S. F. Cody	1,600 feet	
Feb. 23, 1909 Baddeck, Nova Scotia "Silver Dart" J. A. D. McCurdy	4.5 miles	
Feb. 24, 1909 Isny, France Voisin J. T. C. Moore-Brabazon	3,280 feet	
Feb. 24, 1909 Isny, France Voisin J. T. C. Moore-Brabazon	1.2 miles	One circle. Two circles.
Feb. 27, 1909 Isny, France Voisin J. T. C. Moore-Brabazon	3.1 miles	Several flights.
Feb. 28, 1909 Isny, France Voisin J. T. C. Moore-Brabazon	0:11:00	
Mar. 5, 1909 Baddeck, Nova Scotia "Silver Dart" J. A. D. McCurdy	0:22:00	
Mar. 11, 1909 Baddeck, Nova Scotia "Silver Dart" J. A. D. McCurdy	0:13:00	One landing, cross-country. Two circles. This flight makes total of 1,000 miles—over 100 trips over 9-mile course.
Mar. 17, 1909 Pau, France Biplane Wilbur Wright and Katherine	0:21:00	
Mar. 18, 1909 Baddeck, Nova Scotia "Silver Dart" J. A. D. McCurdy	16 miles	
Mar. 18, 1909 Baddeck, Nova Scotia "Silver Dart" Baldwin	0:03:00	
Mar. 19, 1909 Pau, France Wright Count de Lambert	0:09:00	After only 5½ hours' instruction.
Mar. 19, 1909 Pau, France Wright Count de Lambert	0:27:59	After 6½ hours' instruction.
Mar. 19, 1909 Pau, France Wright Count de Lambert	0:27:59	Cross-country. Not substantiated.
Mar. 23, 1909 Texas Biplane C. A. Newman	12 miles	
April 8, 1909 Pau, France Wright Students under Capt. Ferber	984 feet	Short flights. After five lessons.
April 9, 1909 Juvisy, France "Antoinette V" Rene Demanest	80 feet	Wrecked machine.
April 9, 1909 Juvisy, France "Antoinette" Hubert Latham	80 feet	
April 10, 1909 Pau, France Wright Count de Lambert and Rene Gasnier	8,280 feet	
April 12, 1909 Pau, France Wright Count de Lambert and Col. Vives		Lesson flight.
April 12, 1909 Buc, France "Eliot" Maurice Guifroy		Lesson flight.
April 12, 1909 Buc, France R. E. P. Wilbur Wright		Both caught in gusts with little dam-
April 15, 1909 Rome, Italy Biplane Wilbur Wright	0:10:00	Lesson flight.
April 16, 1909 Rome, Italy Biplane Wilbur Wright and Lieut. Calderara	0:06:30	
April 16, 1909 Rome, Italy Biplane Wilbur Wright and Capt. Bagnasco	0:07:00	
April 16, 1909 Rome, Italy Biplane Wilbur Wright and Lieut. Savoia	0:08:00	
April 19, 1909 Centocelle, Italy "Antoinette VI" Hubert Latham	4,921 feet	
April 19, 1909 Centocelle, Italy Biplane Capt. Buregat	300 feet	
April 19, 1909 Centocelle, Italy Biplane Wilbur Wright and Lieut. Hubert Latham	0:30:00	
April 22, 1909 Buc, France Voisin Baron de Caters	3 flights	
April 24, 1909 Buc, France Voisin M. Legagneux	3,100 feet	
April 25, 1909 Buc, France Biplane M. Legagneux	4,020 feet	
April 25, 1909 Buc, France Biplane Henry Farman	1.25 miles	
April 25, 1909 Buc, France Biplane Maurice Guifroy	3.10 miles	
April 25, 1909 Buc, France "E. P. 3" Hubert Latham	8,000 feet	
April 25, 1909 Buc, France "Antoinette" Hubert Latham	984 feet	
April 28, 1909 Centocelle, Italy Wright Lieut. Calderara	4.8 miles	
April 29, 1909 Chalons, France "Antoinette VI" Rene Demanest	0:05:00	
April 30, 1909 Chalons, France "Antoinette VI" Rene Demanest	9.32 miles	
April 30, 1909 Chalons, France Voisin J. T. C. Moore-Brabazon	4.5 miles	
May 2, 1909 England Voisin J. T. C. Moore-Brabazon	600 feet	
May 2, 1909 England Voisin J. T. C. Moore-Brabazon	1,500 feet	
May 6, 1909 Rome, Italy Wright Lieut. Calderara		Machine upset by gust; Calderara hurt.
May 13, 1909 Aidershot, England Army biplane S. F. Cody	1 mile	Three short flights.
May 14, 1909 Aidershot, England Army biplane S. F. Cody	600 feet	Damaged by gust.
May 14, 1909 Aidershot, England Army biplane S. F. Cody	1,640 feet	
May 15, 1909 Chalons, France "Antoinette" Hubert Latham		
May 16, 1909 Chalons, France "Antoinette" Hubert Latham and M. Demanest	1,640 feet	

TABULAR HISTORY OF FLIGHTS—Continued

May 20, 1909	Chalons, France	Antoinette	Hubert Latham & M. L. Bouché	1,978 feet	
May 20, 1909	Pau, France	Wright	Paul Tissandier	35.72 miles	
May 21, 1909	Chalons, France	Antoinette	Hubert Latham		
May 21, 1909		Wright	Paul Tissandier and M. L. blanc		
May 21, 1909		Wright	Paul Tissandier and M. L. blanc		
May 22, 1909	Buc, France	Volsin	M. Rouger	18.63 miles	
May 22, 1909	Buc, France	R. E. P.	Marice Guifroy	2,640 feet	
May 22, 1909	Buc, France	R. E. P.	Marice Guifroy	2.36 miles	
May 23, 1909	Juvisy, France	R. E. P.	Maurice Guifroy	6 miles	
May 24, 1909	Juvisy, France	Volsin	Leon Delarange	8.6 miles	
May 30, 1909	Issy, France	"Bleriot XI"	Louis Bleriot	0:40:00	
June 5, 1909	Hammondsport, N. Y.	"Antoinette"	Hubert Latham	1:07:37	
June 5, 1909	Juvisy, France	"Golden Flyer"	Glenn H. Curtiss	8 miles	
June 6, 1909	Juvisy, France	Antoinette	Hubert Latham	10 miles	
June 7, 1909		Monoplane	Louis Bleriot and Andre Fournier	1,978 feet	
June 7, 1909	Juvisy, France	Volsin	Leon Delarange	1.24 miles	
June 8, 1909		Antoinette	Hubert Latham	8 miles	
June 8, 1909		Antoinette	Hubert Latham		
June 6, 1909	Morris Park, N. Y.	"Golden Flyer"	Glenn H. Curtiss	2,040 feet	
June 8, 1909	Morris Park, N. Y.	"Golden Flyer"	Glenn H. Curtiss	1 mile	
June 8, 1909	Issy, France	"Bleriot XII"	Louis Bleriot	1,040 feet	
June 11, 1909	Issy, France	"Bleriot XII"	Louis Bleriot	4,320 feet	
June 12, 1909	Juvisy, France	Volsin	Leon Delarange	3.7 miles	
June 12, 1909	Issy, France	"Bleriot XII"	Louis Bleriot, Alberto Santos Dumont and Andre Fournier	984 feet	
June 12, 1909	Issy, France	"Bleriot XII"	Louis Bleriot and mechanic	3.73 miles	
June 13, 1909	Juvisy, France	"Antoinette IV"	Hubert Latham	30.446 miles	
June 13, 1909	Juvisy, France	"Antoinette IV"	Captain Ferber	3.1 miles	
June 14, 1909	Issy, France	"Bleriot XII"	Hubert Latham	1.96 miles	
June 15, 1909	Chalons, France	"Antoinette IV"	Louis Bleriot	11 miles	
June 17, 1909	Morris Park, N. Y.	"Golden Flyer"	Glenn H. Curtiss	2,640 feet	
June 17, 1909	Ft. Meyer, Va.	Biplane	Orville Wright		
June 18, 1909	Morris Park, N. Y.	"Golden Flyer"	Glenn H. Curtiss	2 miles	
June 18, 1909	England	Army biplane	S. F. Cody		
June 18, 1909	Chalons, France	Volsin	M. Paulhan		
June 19, 1909	Issy, France	"Antoinette IV"	Albert Santos-Dumont	820 feet	
June 19, 1909	Issy, France	"Bleriot XI"	Louis Bleriot		
June 19, 1909	Issy, France	Monoplane	Albert Santos-Dumont		
June 19, 1909	Issy, France	Monoplane	Albert Santos-Dumont		
June 23, 1909	Chalons to Sulppes	Wright	Count de Lambert		
June 23, 1909	Chalons, France	"Golden Flyer"	Henry Farman	40 miles	
June 23, 1909	Morris Park, N. Y.	"Golden Flyer"	Glenn H. Curtiss	1 mile	
June 25, 1909	Issy, France	"Bleriot XI"	Louis Bleriot		
June 26, 1909	Issy, France	"Bleriot XII"	Louis Bleriot		
June 28, 1909	Issy, France	"Bleriot XII"	Louis Bleriot		
June 28, 1909	Issy, France	"Bleriot XII"	Louis Bleriot		
June 28, 1909	Ft. Meyer, Va.	Biplane	Orville Wright	3,960 feet	
June 30, 1909	Issy, France	"Bleriot XI"	Louis Bleriot	5,000 feet	
July 1, 1909	Issy, France	"Bleriot XI"	Louis Bleriot		
July 2, 1909	Ft. Meyer, Va.	Biplane	Orville Wright		
July 2, 1909	Ft. Meyer, Va.	Biplane	Orville Wright		
July 2, 1909	Chalons, France	"Antoinette"	M. Gaboriau, Alme, Colliere		
July 2, 1909	Chalons, France	"Antoinette"	M. Gaboriau, Alme, Colliere		
Lesson flight				0:08:00	
Eleven flights				0:04:30	
Several flights, including turn					
0:48:00					
0:10:18%					
1:07:37					
In wind and rain					
Figure-eight curves					
Cross-country					
At 68 miles an hour					
At 81 miles an hour					
against it					
In two flights					
Five passengers, one after another					
Cut off power at 60 feet high, started					
at 100 feet, then					
glided again to ground—all in 16-					
mile wind					
Figure eight					
Straightaway					
Two turns					
Broke wing					
In two flights					
At 45 miles an hour					
Two short flights					
New height record, 450 feet					
Also several shorter flights					
Total time in five flights					
Brose rudder					
Cross-country, 150 feet high					
At 43 miles an hour					
Eleven circles in strong wind					
Two short flights with passenger					
In 13 to 20-mile wind					
In closed circle					
0:07:00					
0:12:00					
0:05:00					
0:12:00					
0:36:35%					
0:06:11					
0:07:00					
0:12:00					
0:05:00					

TABULAR HISTORY OF FLIGHTS—Continued

July 8, 1909	Brayelle, France	Monoplane	Louis Bleriot	17.3 miles	0:47:17	Twenty-four circuits.
July 4, 1909	Juvisy, France	Monoplane	Louis Bleriot	3.75 miles	0:50:08	
July 5, 1909	Chalons, France	Farman	Roger Sommer	1.86 miles	0:30:00	
July 9, 1909	Juvisy, France	Wright	Count de Lambert			
July 9, 1909	France, France	Monoplane	Louis Bleriot			Several short flights.
July 10, 1909	Douai, France	Volsin	M. Paulhan	1.24 miles	0:05:38	At first attempt.
July 12, 1909	Ft. Myer, Va.	Biplane	Orville Wright			
July 13, 1909	Douai, France	Volsin	M. Paulhan	2,640 feet	0:15:00	Two flights.
July 13, 1909	Ft. Myer, Va.	Biplane	Orville Wright	2,640 feet		in flight.
July 13, 1909	Ft. Myer, Va.	Biplane	Orville Wright	2,640 feet		One landing.
July 13, 1909	Mineola, L. I.	"Golden Flyer"	Glehn H. Curtiss	1,600 feet	0:03:00	
July 13, 1909	Mineola, L. I.	"Golden Flyer"	Glehn H. Curtiss	1.5 miles	0:45:00	
July 13, 1909	Mineola, L. I.	"Bleriot XI"	Louis Bleriot	33 miles	0:07:20	Stamps to Toury, then Chevilly.
July 14, 1909	Mineola, L. I.	"Golden Flyer"	Glehn H. Curtiss	3.1 miles	0:43:00	Total time in several flights.
July 14, 1909	Juvisy, France	Wright	Paul Tissandier			
July 15, 1909	Douai, France	"Golden Flyer"	M. Paulhan			
July 16, 1909	Mineola, L. I.	"Golden Flyer"	Glehn H. Curtiss	3,000 feet	0:05:00	Total in two flights.
July 17, 1909	Mineola, L. I.	"Golden Flyer"	Glehn H. Curtiss		0:07:20	
July 17, 1909	Chalons, France	Farman	Roger Sommer	0:30:00		
July 17, 1909	Mineola, L. I.	"Golden Flyer"	Glehn H. Curtiss	15 miles	0:26:00	Described figure eight
July 18, 1909	Ft. Myer, Va.	Biplane	Orville W. Wright		1:04:00	
July 18, 1909	Chalons, France	Farman	Roger Sommer		0:52:30	
July 18, 1909	Mineola, L. I.	"Golden Flyer"	Glehn H. Curtiss	30 miles	0:01:37	Official distance, 24.947 miles
July 18, 1909	Juvisy, France	Volsin	Pelot Gaudart		0:01:59	Three circuits of course.
July 18, 1909	Douai, France	"Bleriot XI"	Louis Bleriot	.62 mile	0:57:40	Race.
July 18, 1909	Douai, France	"Bleriot XI"	Louis Bleriot	1.94 miles	0:57:40	
July 18, 1909	Douai, France	Volsin	M. Paulhan	6 miles	0:08:00	590 feet high.
July 19, 1909	English Channel	"Antoinette IV"	Hubert Latham	17 miles	0:25:00	Went in water.
July 19, 1909	Ft. Myer, Va.	Biplane	Orville Wright	20 miles	0:30:00	
July 19, 1909	Ft. Myer, Va.	Biplane	Orville Wright	12.43 miles	1:23:00	Cross-country.
July 19, 1909	Chalons, France	Volsin	Henry Farman	12.43 miles	1:15:00	Total time of four flights.
July 20, 1909	Chalons, France	Farman	Roger Sommer		0:20:45	
July 20, 1909	Ft. Myer, Va.	Biplane	Orville Wright	2 miles	0:05:00	With one landing.
July 21, 1909	La Hays, Holland	Wright	M. Lefebvre	2.17 miles	0:14:00	
July 21, 1909	Juvisy, France	Volsin	Pelot Gaudart	4 miles	0:17:00	
July 21, 1909	Ft. Myer, Va.	Biplane	Orville Wright		0:38:00	
July 22, 1909	Chalons, France	Biplane	Henry Farman		1:05:00	
July 22, 1909	Chalons, France	Farman	Roger Sommer		0:11:00	
July 22, 1909	Chalons, France	Farman	Roger Sommer		1:17:19	
July 23, 1909	Douai, France	Farman	Cockburn	48.5 miles	1:05:00	Official distance, 29.84 miles
July 23, 1909	Douai, France	Volsin	M. Paulhan	40 miles	1:05:00	150 feet high
July 23, 1909	Chalons to Sulpes, France	Biplane	M. Paulhan			One circuit of course.
July 24, 1909	Juvisy, France	Volsin	Henry Farman			
July 24, 1909	Ft. Myer, Va.	Biplane	Pelot Gaudart			First flight in Russia.
July 24, 1909	Mineola, L. I.	"Golden Flyer"	Glehn H. Curtiss	25 miles	0:52:30	
July 25, 1909	Odessa, Russia	Volsin	Van der Schrouff	9.26 feet		Stearns to Dover
July 25, 1909	English Channel	"Bleriot XI"	Louis Bleriot	25 miles	0:37:00	Started without weight, against 18 mile wind.
July 26, 1909	Fort Myer, Va.	Biplane	Orville Wright	4 miles		Went in water.

TABULAR HISTORY OF FLIGHTS—Continued

July 27, 1906	English Channel	"Antoinette VIII"	Hubert Latham	19 miles	
July 27, 1909	Voisin, France	Voisin	Pelot Gaudart	435 miles	1:23:30	Fell in sea.
July 28, 1909	Châlons, France	Farman	Roger Sommer	6.21 miles	
July 28, 1909	Voisin, France	Voisin	Pelot Gaudart	3.1 miles	
July 30, 1909	Fort Myer, Va.	Biplane	Orville Wright and Lieut. Lahm	1:23:20	
July 30, 1909	Fort Myer, Va.	Biplane	Orville Wright and D. Glenn H. Curtiss	10 miles	0:14:42	Cross-country.
July 31, 1909	Minneapolis, L. I.	"Golden Flyer"	Pelot Gaudart	3.1 miles	0:07:34	
Aug. 1, 1909	Voisin, France	Voisin	Roger Sommer	1:50:30	Forty-five miles an hour.
Aug. 2, 1909	Châlons, France	Farman	Roger Sommer	9 miles	0:12:00	
Aug. 2, 1909	Châlons, France	Farman	Roger Sommer	Several short flights.
Aug. 3, 1909	Stockholm, Sweden	"Silver Dart"	J. A. D. McCurdy and Edwin H. Higgs	3 miles	0:48:00	First flight in Sweden.
Aug. 3, 1909	Châlons, France	Biplane	Henry Farman	0:14:00	
Aug. 3, 1909	Châlons, France	Voisin	Jean Gobron	Three short flights.
Aug. 3, 1909	Minneapolis, L. I.	"Golden Flyer"	Glenn H. Curtiss	Two circuits of course.
Aug. 3, 1909	Châlons, France	Farman	M. Cocksburn	0:15:00	
Aug. 4, 1909	Châlons, France	Farman	Roger Sommer	2:06:40	
Aug. 4, 1909	Châlons, France	Farman	Roger Sommer	0:15:20	
Aug. 5, 1909	Châlons, France	Voisin	Etienne Bnanu-Yarilla	1,640 feet	In closed circle.
Aug. 5, 1909	Issy, France	Monoplane	Louis Bleriot	3,280 feet	
Aug. 6, 1909	Châlons, France	Farman	Roger Sommer	
Aug. 6, 1909	Stockholm, Sweden	Voisin	M. Legagneux and Erik M. Paulhan	8,980 feet	0:15:50	
Aug. 6, 1909	Dunkerque, France	Voisin	M. Paulhan	12.4 miles	2:27:15	
Aug. 7, 1909	Châlons, France	Farman	Roger Sommer	23 miles	1:32:45	
Aug. 7, 1909	Dunkerque, France	Voisin	M. Paulhan	12 miles	0:15:00	
Aug. 7, 1909	Rome, Italy	Wright	Lient. Savoia	4 miles	Four low flights.
Aug. 7, 1909	Minneapolis, L. I.	"Golden Flyer"	Charles Foster Willard	7 miles	Five flights.
Aug. 8, 1909	Minneapolis, L. I.	"Golden Flyer"	Charles Foster Willard	Smallest machine.
Aug. 9, 1909	Minneapolis, L. I.	"Golden Flyer"	Charles Foster Willard	0:16:00	Cross-country.
Aug. 9, 1909	Minneapolis, L. I.	"Golden Flyer"	Charles Foster Willard	0:04:00	Avoided collision by rising over De-
Aug. 14, 1909	Minneapolis, L. I.	"Golden Flyer"	Charles Foster Willard	marest's monoplane.
Aug. 19, 1909	Rheims, France	Biplane	Glenn H. Curtiss	1.8 miles	0:01:58	This time taken in course of longer
Aug. 20, 1909	Minneapolis, L. I.	"Golden Flyer"	Charles Foster Willard	6.21 miles	0:08:55 1/2	In 20-mile wind.
Aug. 22, 1909	Rheims, France	Wright	M. LeFebvre	18.4 miles	0:29:02 1/2	
Aug. 22, 1909	Rheims, France	Wright	Paul Tissandier	0:28:59	
Aug. 22, 1909	Rheims, France	Wright	Count de Lambert	0:09:47	
Aug. 22, 1909	Rheims, France	Antoinette	Hubert Latham	0:11:52	
Aug. 22, 1909	Rheims, France	Farman	Roger Sommer	0:11:30	
Aug. 22, 1909	Rheims, France	Wright	Count de Lambert	0:00:36	
Aug. 22, 1909	Rheims, France	Wright	Paul Tissandier	0:11:58	
Aug. 22, 1909	Rheims, France	Voisin	Etienne Bnanu-Yarilla	0:11:56	
Aug. 22, 1909	Rheims, France	Farman	M. Cocksburn	0:11:56	
Aug. 22, 1909	Rheims, France	Monoplane	Leon Delagrangue	
Aug. 22, 1909	Rheims, France	Wright	Paul Tissandier	
Aug. 22, 1909	Rheims, France	Wright	Paul Tissandier	18.6 miles	0:24:59 1/2	
Aug. 23, 1909	Rheims, France	Biplane	Glenn H. Curtiss	6,135 miles	0:08:35 1/2	
Aug. 24, 1909	Rheims, France	Antoinette	Hubert Latham	18.6 miles	0:36:02 1/2	
Aug. 24, 1909	Rheims, France	Monoplane	Louis Bleriot	6,133 miles	0:08:03 1/2	
Aug. 25, 1909	Rheims, France	Voisin	M. Paulhan	83.07 miles	2:42:24	Went over 500 feet high.
Aug. 25, 1909	Rheims, France	Biplane	Glenn H. Curtiss	
Aug. 25, 1909	Rheims, France	Antoinette	Hubert Latham	6,135 miles	0:08:04 1/2	
Aug. 25, 1909	Odessa, Russia	Antoinette	M. Cattan	Machine wrecked.
Aug. 25, 1909	Odessa, Russia	Antoinette	M. Cattan	

TABULAR HISTORY OF FLIGHTS—Continued

Aug. 26	1909	Rheims, France	"Bleriot XI"	Louis Bleriot	6 miles	0:08:38	
Aug. 26	1909	Rheims, France	Antoinette	Hubert Latham	43.46 miles	1:01:51	At 42 miles per hour.
Aug. 26	1909	Rheims, France	Antoinette	Hubert Latham	96 miles	2:13:09 3/5	Smashed wing.
Aug. 26	1909	Rheims, France	Wright XI	Count de Lambert	68.34 miles	0:55:59 1/5	
Aug. 26	1909	Rheims, France	Biplane	Glenn H. Curtiss	24.39 miles	0:28:59 3/5	
Aug. 26	1909	Rheims, France	Bleriot XI	Louis Bleriot	68.34 miles	1:38:02 1/5	
Aug. 27	1909	Rheims, France	Antoinette	Hubert Latham	1:46:52		No distance allowed for curves. Time was taken at 111.78 miles. Rarely over 10 feet high.
Aug. 27	1909	Rheims, France	Biplane	Henry Farman	118.06 miles	3:04:56 2/5	
Aug. 27	1909	Rheims, France	Farman	Roger Sommer	37.28 miles	0:21:34 2/5	
Aug. 27	1909	Rheims, France	Farman	Louis Delaunay	31 miles	0:15:31	
Aug. 27	1909	Rheims, France	Antoinette	Hubert Latham	48.5 miles	0:53:08 1/5	
Aug. 27	1909	Dunkirk, France	Wright	M. Baratreux	1,600 feet		
Aug. 28	1909	Rheims, France	Biplane	M. Lefevre	13.04 miles	0:15:50 3/5	At 47.65 miles an hour.
Aug. 28	1909	Rheims, France	Bleriot XI	Glenn H. Curtiss	12.43 miles	0:07:56 1/5	
Aug. 28	1909	Rheims, France	Bleriot XI	Louis Bleriot	12.43 miles	0:07:56 1/5	
Aug. 28	1909	Rheims, France	Bleriot XI	M. Lefevre	12.43 miles	0:20:47 3/5	
Aug. 28	1909	Rheims, France	"Bleriot XI"	Louis Bleriot	6.2 miles	0:07:47 4/5	At 47.8 miles an hour.
Aug. 28	1909	Rheims, France	Antoinette	Hubert Latham	12.43 miles	0:08:40 4/5	
Aug. 28	1909	Rheims, France	Biplane	Henry Farman	6.2 miles	0:17:32	With passenger.
Aug. 28	1909	Berlin, Germany	Biplane	Orrille Wright	6.2 miles	0:10:29 2/5	
Aug. 28	1909	Rheims, France	Biplane	Glenn H. Curtiss	18.6 miles	0:31:00 1/5	
Aug. 28	1909	Rheims, France	Biplane	Glenn H. Curtiss	18.6 miles	0:25:39	
Aug. 28	1909	Rheims, France	Biplane	Glenn H. Curtiss	18.6 miles	0:26:40	
Aug. 28	1909	Rheims, France	Antoinette	Hubert Latham	18.6 miles	0:25:18 1/5	
Aug. 28	1909	Rheims, France	Biplane	Glenn H. Curtiss	18.6 miles	0:26:33 1/5	
Aug. 28	1909	Rheims, France	Biplane	Glenn H. Curtiss	18.6 miles	0:23:29	
Aug. 28	1909	Rheims, France	Biplane	Count de Lambert	18.6 miles	0:27:51 3/5	Over 300 feet high. Over 400 feet high.
Aug. 28	1909	Rheims, France	Antoinette	Hubert Latham	4.5 miles		In three flights.
Aug. 28	1909	Aldershot, England	Biplane	S. F. Cody	10 miles	0:15:00	
Aug. 28	1909	Aldershot, England	Biplane	S. F. Cody and mechanic	3.35 feet		In close circle; also two untimed flights. Attempt to cross Lake Ontario, Went in water.
Aug. 30	1909	Germany	Biplane	M. de Nabas	3,980 feet	0:01:15	
Sept. 2	1909	Juvisy, France	Koechlin	Chpt. Ferber	3,980 feet		
Sept. 3	1909	Juvisy, France	Volsin	Chpt. Ferber			
Sept. 3	1909	Toronto, Canada	"Golden Flyer"	Charles Foster Willard			
Sept. 4	1909	Berlin, Germany	Biplane	Orrille Wright		0:19:00	Three flights; one with passenger.
Sept. 5	1909	Tournaï, France	Volsin	M. Faulhan		0:35:00	Three flights; Mme. Splrs. as passenger. Lefevre killed. Machine fell only ten feet.
Sept. 6	1909	Nancy, France	Farman	Roger Sommer			
Sept. 6	1909	Nancy, France	Farman	Roger Sommer			
Sept. 7	1909	Juvisy, France	Wright	Jugene Lefevre	1,800 feet		
Sept. 7	1909	St. Cyr, France	Monoplane	Count de Lambert			
Sept. 7	1909	St. Cyr, France	Biplane	Orrille Wright		0:55:00	
Sept. 7	1909	Boulogne to Wimereux, France	Volsin	Capt. Ferber	10 miles	0:11:00	Round trip cross-country, with landing.
Sept. 8	1909	Berlin, Germany	Biplane	Orrille Wright		0:35:56	
Sept. 8	1909	Berlin, Germany	Biplane	Orrille Wright and Capt. S. Reichardt		0:17:00	
Sept. 8	1909	Aldershot, England	Biplane	Orrille Wright	40 miles	1:03:00	
Sept. 8	1909	Germany	Biplane	Orrille Wright and Capt. Reichardt		0:20:00	
Sept. 9	1909	Brescia, Italy	Volsin	M. Rouger	1.86 miles	0:15:00	Reached height of 328 feet.
Sept. 9	1909	Brescia, Italy	Volsin	M. Rouger			
Sept. 9	1909	Aldershot, England	Biplane	S. F. Cody, Capt. Brooke			

TABULAR HISTORY OF FLIGHTS—Continued

Sept. 9, 1909.	Nancy, France.	Farnum	Roger Sommer	12.4 miles	0:17:00	In two cross-country flights.
Sept. 9, 1909.	Journal, France.	Voisin	M. Paulhan	38 miles	1:02:38	Stopped engine and glided to ground.
Sept. 10, 1909.	Berlin, Germany.	Biplane	Orville Wright	19.6 miles
Sept. 10, 1909.	Nancy, France.	Farnum	Roger Sommer, Mdlle. Savoir, and Mdlle. Marvingt	Two flights; one passenger in each.
Sept. 11, 1909.	Nancy to Lenoncourt, France.	Farnum	Roger Sommer	24 miles	Round trip cross country; landed at Lenoncourt.
Sept. 11, 1909.	Brescia, Italy.	Biplane	Glenn H. Curtiss	31.06 miles	0:49:24	Reached height of 377 feet.
Sept. 11, 1909.	Brescia, Italy.	Voisin	M. Rouger	0:42:16	Two short flights.
Sept. 11, 1909.	Aldershot, England.	Biplane	S. F. Cody	0:03:00
Sept. 11, 1909.	Berlin, Germany.	Biplane	Orville Wright	1:22:12
Sept. 11, 1909.	Berlin, Germany.	Biplane	Orville Wright and Capt. von Kehler
Sept. 12, 1909.	Brescia, Italy.	Voisin	M. Rouger	6.3 miles
Sept. 12, 1909.	Brescia, Italy.	Wright	Lieut. Calderara and Lieut. Savoia
Sept. 12, 1909.	Brescia, Italy.	Wright	Lieut. Calderara and Gabriele d'Annunzio	1 mile
Sept. 12, 1909.	Brescia, Italy.	Biplane	Glenn H. Curtiss and Gabrielle d'Annunzio
Sept. 12, 1909.	Nancy, France.	Farnum	Roger Sommer, Mdlle. Savoir, Roger Sommer, Mdlle. Lathamer, M. Friant, Sommer, Jr., M. Thiry	:00:00	Six flights, four with passengers.
Sept. 13, 1909.	Nancy, France.	Farnum	Roger Sommer, M. Feltz, M. Munier, M. Thiry, Mme. Mancy, Mlle. Lathamer, Mlle. Sommer, Mdlle. Lathamer, and Sommer, Jr.
Sept. 13, 1909.	Journal to Taintegules, France.	Voisin	M. Paulhan	Eight flights, seven with passengers.
Sept. 13, 1909.	Berlin, Germany.	Biplane	Orville Wright and Prof. Hegenbarth	1:35:00	Cross-country, with one landing.
Sept. 13, 1909.	St. Cyr to Buc, France.	Monoplane	Alberto Santos-Dumont	5 miles	0:10:00	One flight alone; both in high wind.
Sept. 13, 1909.	Châlons, France.	Voisin	M. Sanchez-Besa	0:12:00	Off ground with 130-foot run; round trip.
Sept. 15, 1909.	Brescia, Italy.	Wright	Lieut. Calderara and Lieut. Savoia	6.2 miles
Sept. 17, 1909.	St. Cyr to Widenulle, France.	Monoplane	Alberto Santos-Dumont	5.6 miles
Sept. 17, 1909.	Berlin, Germany.	Biplane	Orville Wright	10.56 miles
Sept. 17, 1909.	Ostend, Belgium.	Voisin	Louis Paulhan
Sept. 18, 1909.	St. Cyr, France.	Monoplane	Alberto Santos-Dumont	1.24 miles	0:03:15%	Cross-country. Reached height of 765 feet. Circled over sea. Flew with hands off, waving handkerchiefs.
Sept. 18, 1909.	Berlin, Germany.	Biplane	Orville Wright and Capt. F. Latham	1:35:00	Ferber hurt, dying later.
Sept. 22, 1909.	Roulogne, France.	Voisin	Capt. Louis F. Ferber	Details not confirmed.
Sept. 23, 1909.	Oakland, California.	Fung Joe Guey	2,640 feet	Details not confirmed.
Sept. 24, 1909.	Borris, Texas.	Adolph Herf	0:57:00
Sept. 27, 1909.	Berlin to Johannisthal, Germany.	Antoinette	Hubert Latham	With wind. Said to have reached speed of 74½ miles an hour.
Sept. 28, 1909.	Place Machine	Passengers	H. M. S.
Sept. 28, 1909.	Berlin, Germany.	Voisin	M. Kersch	Distance, 31 miles	0:54:00
Sept. 28, 1909.	Johannisthal	Voisin	Louis Heriot	12 miles	0:24:33
Sept. 28, 1909.	Johannisthal	Voisin	Henri Rouger	80 kilom.

TABULAR HISTORY OF FLIGHTS—Continued

Sept. 29, 1909	New York City	Biplane	Wilbur Wright	1:37:21½	Circled Statue of Liberty. Made one other flight.
Sept. 29, 1909	Johannisthal	Antoinette	Hubert Latham	0:56:30	Circled Governor's Island.
Sept. 30, 1909	New York City	Biplane	Glenn H. Curtiss	Reached height of 902 feet. In three flights.
Sept. 30, 1909	Berlin, Germany	Biplane	Orville Wright	4.5 miles
Sept. 30, 1909	Berlin, Germany	Monoplane	Hans Grade	1:21:00
Oct. 1, 1909	Johannisthal	Antoinette	Hubert Latham	2:53:25½
Oct. 1, 1909	Johannisthal	Farman	Henry Farman	1:04:58
Oct. 1, 1909	Johannisthal	Biplane	Wilbur Wright
Oct. 1, 1909	Colonge	Bleriot	Louis Bleriot	0:10:00	Reached height of 1,037 feet.
Oct. 2, 1909	Berlin, Germany	Biplane	Frederick William	0:20:00	Over Hudson River.
Oct. 2, 1909	Berlin, Germany	Biplane	Orville Wright	2:49:00	Reached height of 900 feet.
Oct. 3, 1909	Johannisthal	Farman	Henry Farman	21 miles	Two sharp flights.
Oct. 4, 1909	New York City	Biplane	Wilbur Wright	0:33:33	Plunged 70 feet to ground without injury.
Oct. 7, 1909	Berlin, Germany	Biplane	J. Rouget
Oct. 7, 1909	St. Louis, Mo.	Biplane	Glenn H. Curtiss
Oct. 7, 1909	College Park, Md.	Biplane	Wilbur Wright	0:00:58%
Oct. 9, 1909	St. Louis, Mo.	Biplane	Glenn H. Curtiss	3,280 feet	0:01:49
Oct. 10, 1909	Frankfort	Bleriot	Louis Bleriot	1 mile	1:12:00
Oct. 10, 1909	Frankfort	Voisin	Baronde Caters	1:27:00
Oct. 11, 1909	College Park, Md.	Biplane	Wilbur Wright	1,000 feet	0:00:37%	Made complete circle in this time.
Oct. 11, 1909	Chicago, Ill.	Biplane	Glenn H. Curtiss	0:49:50
Oct. 18, 1909	Frankfort	Biplane	Wright	25 miles	0:19:00	Cross-country; circled Eiffel Tower.
Oct. 19, 1909	College Park, Md.	Biplane	Wilbur Wright	48 miles	1:32:16½
Oct. 21, 1909	Blackpool, England	Biplane	Henry Farman	0:12:00%	Said to have made 80 and 100 miles an hour at times with wind.
Oct. 21, 1909	Javisy, France	Wright	Comte de Lambert	7.5 miles
Oct. 22, 1909	Blackpool, England	Antoinette	Hubert Latham
Oct. 28, 1909	Antwerp	Voisin	Rouget	1:03:08
Oct. 29, 1909	Brooklands	Farman	Capt. Englehardt	2:49:30
Oct. 30, 1909	Brooklands	Wright	Lieuts. Humphreys & Foullos	1.55 miles	0:02:43	Engine stopped. Gilded safely to ground.
Oct. 30, 1909	College Park, Md.	Monoplane	Hans Grade
Oct. 30, 1909	Brooklands, England	Voisin	Louis Paulhan	0:58:30	Reached height of 720 feet.
Nov. 1, 1909	College Park, Md.	Wright	Lieut. Frank P. Lahm	0:16:00
Nov. 1, 1909	College Park, Md.	Wright	Lieut. Frank P. Lahm	96 miles	3:09:00
Nov. 1, 1909	Brooklands, England	Voisin	Louis Paulhan	0:25:25
Nov. 3, 1909	Brooklands, England	Wright	Charles C. Hamilton	1:01:15
Nov. 3, 1909	College Park, Md.	Wright	Lieuts. Humphreys & Foullos	144 miles	4:06:25
Nov. 5, 1909	Mourmelon, France	Biplane	Henry Farman	1:50:00
Nov. 5, 1909	Mourmelon, France	Wright	Capt. Englehardt	1:01:53
Dec. 12, 1909	Chalons	Voisin	Chateau	1:01:53
Dec. 16, 1909	Issy	Farman	J. de Lesseps	1:20:28
Dec. 20, 1909	Chalons	Bleriot	Mortimer Singer	1:01:23
Dec. 20, 1909	Chalons	Voisin	Jacques Balsan	1:31:00
Dec. 30, 1909	Chalons	Bleriot	Delagrange	2:32:00
Dec. 31, 1909	Javisy	Bleriot	Delagrange	1:06:00
Dec. 31, 1909	Chalons	Antoinette	Latham	1:22:00
Dec. 31, 1909	London	Wright	C. S. Rolls	1:04:00
Dec. 31, 1909	Chalons	Farman	H. Farman	1:10:00

HOURLY FLIGHT RECORDS

Jan. 6, 1910.	Bourg	Farman	Van den Born.	1:16:00	
Jan. 11, 1910.	Los Angeles	Curtiss	Glenn Curtiss	1:00:00	
Jan. 16, 1910.	Oran	Bleriot	Oileslaegers	1:05:12½	
Jan. 23, 1910.	Los Angeles	Farman	Louis Paulhan	1:57:27	
Jan. 31, 1910.	Los Angeles	Farman	Louis Paulhan	1:48:40	One passenger
Jan. 31, 1910.	Chalons	Farman	Van den Born.	1:48:50	One passenger
Feb. 6, 1910.	Hellipolis	Voisin	Rouget	1:48:58	
Feb. 9, 1910.	Hellipolis	Voisin	Metrot	65 kilom.
Feb. 11, 1910.	Hellipolis	Voisin	Metrot	85 kilom.
Feb. 28, 1910.	Fau	Farman	Geo. Chaves	1:47:00	
Mar. 2, 1910.	Chalons	Farman	Capt. Bugeat	1:00:00	
Mar. 7, 1910.	Chalons	R. Farman	Lieut. Camermann	1:08:00	
Mar. 6, 1910.	Chalons	Farman	Maurice Farman	1:00:00	
Mar. 6, 1910.	Juvisy	Farman	Farman	1:02:25	Two passengers
Mar. 11, 1910.	Juvisy	Voisin	Caudart	1:10:00	
Mar. 11, 1910.	Le Havre	Bleriot	Molon	1:24:00	
Mar. 17, 1910.	Le Havre	Bleriot	Molon	1:04:00	
Mar. 21, 1910.	Cannes	Wright	Popoff	1:33:00	
Mar. 21, 1910.	Fau	Farman	Gasnier	1:05:00	
Mar. 27, 1910.	Cannes	Farman	Grabame White	1:06:00	
Mar. 27, 1910.	Cannes	Farman	Prechon	1:06:02½	
Apr. 2, 1910.	Fau	Bleriot	Bleriot	1:15:00	
Apr. 2, 1910.	Mourmelon	Farman	D. Kinet	1:02:30	One passenger
Apr. 3, 1910.	Mourmelon	Farman	Gibbs	1:12:00	
Apr. 3, 1910.	Juvisy	Tellier	Dubonnet	1:50:00	
Apr. 4, 1910.	Cannes	Farman	Frey	1:02:33	
Apr. 5, 1910.	Mourmelon	Farman	Sommer, Dubonnet	1:05:00	
Apr. 6, 1910.	Mourmelon	Farman	Capt. Marconnet	1:10:00	
Apr. 8, 1910.	Chalons	Farman	D. Kinet	2:10:00	
Apr. 11, 1910.	Johannisthal	Farman	Jeanin	2:01:55	Two passengers.
Apr. 17, 1910.	San Sebastian, Spain	Bleriot	Le Blon	Le Blon drowned after fall in shallow water
Apr. 17, 1910.	Memphis, Tenn.	Curtiss	Glenn Curtiss	Got off the ground in 5½ seconds
Apr. 17, 1910.	Barcelona, Spain	Curtiss	Godard	Flew over town and harbor.
Apr. 11, 1910.	Brayelle, France	Bleriot	Leblanc	
Apr. 11, 1910.	Aras and back, France	Breguet	Breguet	
Apr. 15, 1910.	Nice, France, to Aras and back	Farman	Chaves	24 9/10 ml.	Cross country.
Apr. 15, 1910.	Nice, France, to Aras and back	Farman	Chaves	65¼ ml.	
Apr. 16, 1910.	Nice, France, to Aras and back	Farman	Ermoif	80 7/10 ml.	
Apr. 19, 1910.	Nice, France, to Aras and back	Farman	Chaves	50 9/10 ml.	1:43:58
Apr. 19, 1910.	Nice, France, to Aras and back	Farman	Van den Born & passenger	38½ ml.	
Apr. 20, 1910.	Mouzon, France	Antoniette	H. Latham	1:10:00
Apr. 20, 1910.	Mourmelon, France	Sommer	M. Sommers, M. Colom, M. Frey	5:00
Apr. 20, 1910.	Mourmelon, France	Sommer	Mdlle. Dutrieux and passenger	6:00
Apr. 23, 1910.	Paris, France	Tellier	Legagneux	1:30:00
Apr. 23, 1910.	London to Manchester	Farman	Dubonnet	Flight over Paris.
Apr. 23, 1910.	London to Manchester	Farman	Grabam E. White	Had to give up at Litchfield, owing to intense cold.

HOUR FLIGHT RECORDS—Continued

Apr. 27, 1910.....	London to Manchester.	Farman	Louis Paulhan	186 mi.	4:11:00	Descended at Lichfield for 8 hrs. rest. Made last 24 miles in 24 minutes.
Apr. 27, 1910.....	London to Manchester.	Farman	Graham E. White	107 mi.	2:35:00	Descended at Roade, 60 miles from London, for rest. Descended at Polesworth owing to engine trouble.
Apr. 27, 1910.....	Mourmelon, France.....	Farman	L'evet, Fecant.....	1:07:00	Flew over Strasburg.
Apr. 27, 1910.....	Mourmelon, France.....	Farman	Chéret and passenge.....	1:32:00	
Apr. 28, 1910.....	Douzy, France.....	R. Sommer	Bouvier.....	1:00:00	
May 3, 1910.....	Strasburg, Germany.....	Antoinette	Winckels.....	1:30:00	
May 10, 1910.....	Rhels, France.....	Hanriot mono-plane	Wagner, Marcel, Hanriot and George Emile.....	
May 11, 1910.....	Euc, France.....	Farman	Christiaens.....	1:37:00	Collision with mark post caused death
May 11, 1910.....	St. Petersburg.....	Wright	Popoff.....	2:08:00	
May 11, 1910.....	Lyons, France.....	Farman	Van den Born.....	34 % mi.	
May 12, 1910.....	Werner Neustadt.....	"Taube" mono-plane	Uher and passenger.....	2:15:00	
May 13, 1910.....	Lyons, France.....	Farman	Van den Born.....	
May 13, 1910.....	Lyons, France.....	Antoinette	Hauvette Michelin.....	1:39:00	
May 13, 1910.....	Lyons, France.....	Sommer	Lévesneux.....	1:01:00	
May 13, 1910.....	Herlin.....	Farman	Chavez.....	2:36:25	
May 13, 1910.....	Berlin.....	Farman	Jennin.....	2:24:45	
May 13, 1910.....	Mourmelon, France.....	Wright	Capt. Engelhardt.....	1:50:00	
May 13, 1910.....	Mourmelon, France.....	Farman	Marinet.....	1:28:00	
May 13, 1910.....	Enghien, France.....	Wright	Yennin.....	1:48:00	
May 14, 1910.....	Mourmelon, France.....	Farman	Téard and passenger.....	1:10:00	Cross country to Sedan, Charleville and re-turn.
May 15, 1910.....	Mouzon, France.....	Sommer biplane.	R. Sommer.....	ab. 50 mi.	
May 15, 1910.....	France.....	Antoinette	Wachter.....	2:02:00	Made one stop. Cross country.
May 15, 1910.....	Mourmelon, France.....	Farman	Martinet.....	1:45:00	
May 15, 1910.....	Mourmelon, France.....	Farman	Nichols Kinet and passen.....	2:51:10	
May 15, 1910.....	Mourmelon, France.....	Farman	Van den Born.....	2:23:00	
May 16, 1910.....	Wiener Neustadt.....	"Taube" mono-plane	Illner.....	49 7/10 mi.	
May 17, 1910.....	Wiener Neustadt to Vienna and back.....	"Taube" mono-plane	Illner.....	
May 20, 1910.....	Mouzon to Sedan.....	Sommer biplane.	Illner.....	54 mi.	1:14:00	
May 20, 1910.....	Mourmelon, France.....	Farman	Comte.....	90 % mi.	1:01:00	
May 21, 1910.....	Brooklands, England.....	Neale monoplane.	Capt. Marconnet.....	1:30:00	
May 21, 1910.....	Brooklands, England.....	Neale monoplane.	Neale.....	200 to 400 yards	
May 21, 1910.....	Euc, France, Etampes, France, Calais, France, to Dover, England.....	Farman	Maurice Farman and M. Tabuteau.....	49 7/10 mi.	
May 21, 1910.....	Johannisthal, Germany.....	Bleriot	Comte Jacques de Lesseps.....	49:00	Cross channel flight.
May 23, 1910.....	Mourmelon, France.....	Farman	Frey.....	46:00	Flew over the kaiser's palace.
May 23, 1910.....	Mourmelon, France.....	Farman	Martinet.....	89 mi.	1:30:00	Started for Paris, but got lost in the fog and had to descend.
May 29, 1910.....	Albany to New York.....	Curtiss biplane.	Glenn Curtiss.....	150 mi.	2:32:00	Average speed 54 miles an hour. One stop
May 31, 1910.....	Frankfort, Indiana to Indianapolis.....	Wright	A. Euler.....	115 mi.	1:19:00	Altitude 4,364 feet
June 2, 1910.....	England to France and back.....	Wright	Walter Brookins.....	
June 9, 1910.....	Chateaux to Paris.....	Wright	C. S. Rolls.....	100 mi.	2:30:00	
June 13, 1910.....	N. Ohio and back.....	Curtiss	Marconnet and Féquaut.....	175 mi.	3:27:00	
June 15, 1910.....	Topeka, Kansas.....	Curtiss	Hamilton.....	15 mi.	

HOOR FLIGHT RECORDS—Continued

June 18, 1910.....	Stettin, Germany.....	Aviatik.....	Thaddeus Robl.....	High wind—Robl killed.
June 20, 1910.....	France.....	Antoinette.....	Thaddeus Robl.....	Mourmelon to Betheny, then Chaons to Mourmelon.
July 3, 1910.....	Reims, France.....	Antoinette.....	Rene Labouchere.....	Wing broke—piloter killed.
July 9, 1910.....	Reims, France.....	Antoinette.....	Rene Labouchere.....	211 miles	4:37:00	First 200-mile flight.
July 10, 1910.....	Reims, France.....	Bleriot.....	Jan Ollieslaegers.....	244 miles	5:35:00	First 5-hour flight.
July 10, 1910.....	Belgium.....	Farman.....	Daniel Kinet.....	Lost control—Kinet killed.
July 12, 1910.....	Southbourne, England.....	Wright.....	Hon. Charles Stewart.....	Vol-planing—Rolls killed.
Aug. 3, 1910.....	Brussels, Belgium.....	Farman.....	Rolls.....	Motor stopped—Kinet killed.
Aug. 7, 1910.....	France.....	Bleriot.....	Nicholas Kinet.....	485 miles	Paris, Troyes, Nancy, Meszlers, Douai, Amiens and Paris in ten days.
Aug. 10, 1910.....	Over Irish Sea.....	Farman.....	Robert Lorraine.....	60 miles	50 miles over water.
Aug. 10, 1910.....	Lanark, Scotland.....	Bleriot.....	John B. Badley.....	1 mile	0:00:47 2-5	With wind.
Aug. 17, 1910.....	From Paris, France.....	Bleriot.....	James B. Moisant and Albert Fleux.....	225 miles	Attempt to reach London. Landed within 30 miles, and required 8 weeks to cover remaining distance.
Aug. 20, 1910.....	Across Long Island Sound.....	Farman.....	Clifford B. Harmon.....	25 miles	0:23:00	From Garden City, N. Y., to Greenwich, Conn.
Aug. 20, 1910.....	Italy.....	M. Farman.....	Lieut. Marquis Pasqua Vivaldi.....	Lost control—Vivaldi killed.
Sept. 27, 1910.....	Arnhem, Holland.....	Sommer.....	Clement Van Maasdyk.....	Broke wing—Van Maasdyk killed.
Sept. 28, 1910.....	Ostend, Belgium.....	Farman.....	Eleine Dutrieu and passenger.....	28 miles	Record for woman pilot. Ascended to 1,300 feet.
Sept. 7, 1910.....	From Paris.....	Farman.....	Weyman and Manuel Fay.....	215 miles	Landed because of fog and darkness when about 20 miles from Puy de Dome mountain.
Sept. 12, 1910.....	Boston, Mass.....	Farman.....	Claude Grahame-White.....	33 miles	0:34:00	Around Boston Light.
Sept. 22, 1910.....	Donatossola, Italy.....	Bleriot.....	Georges A. Chavez.....	Vol-planing—Chavez died from injuries.
Sept. 25, 1910.....	Chartres, France.....	Savary.....	Edmond Polliot.....	Upset by wind—Polliot killed.
Sept. 28, 1910.....	Habsheim, Germany.....	Aviatik.....	Ernst Plochmann.....	Lost control—Plochmann killed.
Sept. 29, 1910.....	Chicago to Springfield, Ill.....	Wright.....	Walter Brookins.....	192.5 miles	5:49:06	Two stops.
Oct. 1, 1910.....	Germany.....	Wright.....	Heinrich Haas.....	Wing broke—Haas killed.
Oct. 7, 1910.....	St. Petersburg, Russia.....	Farman.....	Capt. Leon M. Matzlevitch.....	Vol-planing—Matzlevitch killed.
Oct. 8, 1910.....	Springfield, Ill., to St. Louis, Mo.....	Wright.....	Arch Hoxsey.....	109 miles	3:43:00	One stop.
Oct. 23, 1910.....	La Brayelle, France.....	Breguet.....	Capt. Louis Madlot.....	Belgium.
Oct. 25, 1910.....	Magdeburg, Germany.....	Wright.....	Wolheim Mente.....	First attempt—Madlot killed.
Oct. 26, 1910.....	Paris, France.....	Bleriot.....	Fernand Blanchard.....	Vol-planing—Mente killed.
Oct. 27, 1910.....	Rome, Italy.....	Asteria.....	Lieut. Giuseppe Siglietti.....	Crushed by motor in slight fall—Blanchard killed.
Oct. 28, 1910.....	Belmont Park, N. Y.....	Wright.....	Maurice Tabuteau.....	290 miles	6:01:35	Jumped out of machine—Siglietti killed.
Oct. 28, 1910.....	Belmont Park, N. Y.....	Wright.....	Arch Hoxsey.....	First six-hour flight.
Oct. 28, 1910.....	Belmont Park, N. Y.....	Wright.....	Ralph Johnstone.....	Ascended into wind of 70 miles an hour, causing the machines to go backwards while progressing at full speed into the wind.

HOUR FLIGHT RECORDS—Continued

Oct. 28, 1910.	From Paris, France.	Farman	Landed 20 miles from Brussels, 9,714 feet altitude.
Oct. 31, 1910.	Belmont Park, N. Y.	Wright	Flew from deck U. S. cruiser Birmingham and landed on shore.
Nov. 14, 1910.	Hampton Roads, Va.	Curtiss	0:05:00	Control failed—Johnstone killed.
Nov. 17, 1910.	Denver, Colo.	Wright	Control failed—both killed.
Nov. 18, 1910.	England	Howard-Wright	3:12:30	10,148 feet—official.
Dec. 3, 1910.	England	Howard-Wright	177 miles	Greatest duration of continuous flight.
Dec. 3, 1910.	Rome, Italy	Farman	Lost at sea—never found.
Dec. 9, 1910.	Pan, France.	Rleriot	Run over by machine on ground—Picollo killed.
Dec. 18, 1910.	Etampes, France.	Farman	289 miles	11,474 feet high—not officially a record.
Dec. 22, 1910.	North Sea.	Short-Wright	10,575 feet altitude.
Dec. 23, 1910.	Sao Paulo, Brazil.	Bleriot	Control failed—both killed.
Dec. 26, 1910.	Los Angeles, Cal.	Wright	Control failed—Cammont killed.
Dec. 26, 1910.	Los Angeles, Cal.	Wright	Greatest distance in continuous flight.
Dec. 28, 1910.	Paris, France.	Antonette	Moisant killed.
Dec. 30, 1910.	Buc, France	Nieuport	7:48:31	Vol-planing—Horsely killed.
Dec. 31, 1910.	Laflan's Plain, England	Cody	185 miles	Landed upon machine started from beach of U. S. Cruiser Pennsylvania
Dec. 31, 1910.	Buc, France.	R. E. P.	330 miles	Time not officially a record.
Dec. 31, 1910.	New Orleans, La.	Bleriot	6:30:00	Started from water.
Dec. 31, 1910.	Los Angeles, Cal.	Wright	Landed on water within 10 miles of Havana.
Jan. 9, 1911.	Belgrade, Servia.	Russian	Vol-planing—both killed.
Jan. 18, 1911.	San Francisco, Cal.	Curtiss	Came down upon and started from machine, beach and water with same machine.
Jan. 21, 1911.	Lima, Peru.	Died from injuries a couple of weeks later.
Jan. 26, 1911.	San Diego, Cal.	Curtiss	25 miles	Vol-planing—Stein killed.
Jan. 30, 1911.	From Key West, Fla.	Curtiss	85 miles	Vol-planing—both killed.
Feb. 2, 1911.	Paris to Boulogne.	Farman	493 miles
Feb. 6, 1911.	Doberlitz, Germany.	Farman
Feb. 11, 1911.	Donzy, France.	Sommer
Feb. 16, 1911.	San Francisco, Cal.	Wright
Feb. 26, 1911.	San Diego, Cal.	Curtiss
Mar. 2, 1911.	Baton Rouge, La.	Gates
Mar. 3, 1911.	Laredo to Eagle Pass, Texas.	Wright	116 miles
Mar. 5, 1911.	From Antibes, France.	Bleriot	125 miles
Mar. 7, 1911.	Paris to Clermont-Ferrand.	Maurice Farman.	235 miles
Mar. 7, 1911.	City of Mexico.	Bleriot

Landed on small area on Puy de Dome—altitude 4,813 feet high. One 14 minutes en route. 12,062 feet altitude—not official.

HOUR FLIGHT RECORDS—Continued

Mar. 9, 1911.....	France	Nieuport	Nieuport and two others.	62.2 miles	0:59:24
Mar. 11, 1911.....	France	Deperdussin	Bussion and three others.	31 miles	0:31:23
Mar. 12, 1911.....	France	Deperdussin	Bussion and four others..	31 miles	0:31:35 1-5
Mar. 19, 1911.....	Mourmelon to Rieims, France.	Nieuport	Lieut. F e u a n t and	37.75 miles	0:43:00
Mar. 21, 1911.....	Juvisy, France.....	Silone	Louis Breguet and eleven	2 miles
Mar. 23, 1911.....	Douai, France.....	Breguet	others.
Mar. 24, 1911.....	Douzy, France.....	Sommer	Roger S o m m e r and
			twelve others.
			Brey.
Mar. 28, 1911.....	Ile de Rothschild, France.	Caudron	Joseph Cel.
Mar. 30, 1911.....	Toulouse, France.	Bleriot	Morin	100 miles	1:40:00
Mar. 30, 1911.....	Douzy, France.....	Volsin	Bregi	2:00:00
Mar. 31, 1911.....	Pottiers to Paris, France.	Morane	Vedrine	208 miles	2:12:00
Mar. 31, 1911.....	France.....	Nieuport	Nieuport and two others.	68.4 miles	1:04:58
Apr. 2, 1911.....	Deepfritz, Germany.....	Euler	Lieut. Erler and passen-	421 miles
			ger.
Apr. 12, 1911.....	London to Paris.....	Bleriot	Pierre Prier.....	250 miles	3:56:00
Apr. 17, 1911.....	France.....	M. Farman	Lieut. E. Ryasson.....
Apr. 17, 1911.....	France.....	M. Farman	Capt. E. Bonard Yaron..
Apr. 18, 1911.....	San Francisco, France.	Pine	Yallon
May 6, 1911.....	Shanghai, China.....	Sommer	Reue
May 10, 1911.....	San Antonio, Texas.....	Curtiss	Lieut. Geo. G. M. Kelly.
May 11, 1911.....	Johannesthal, Germany.....	Herr	Beckmuller.....
May 17, 1911.....	Los Angeles, Cal.....	Hardlee	A. V. Hardie.....
May 18, 1911.....	Reims, France.....	Deperdussin	Pierre Marie Bourlique
			and Lieut. Paul Dupuis
May 22, 1911.....	Paris to Angouleme.....	Morane	Vedrine	279 miles	3:39:00
May 23, 1911.....	Angouleme to San Se-	Morane	Vedrine	233 miles	3:49:00
	bastian	
May 24, 1911.....	San Sebastian to Bur-	Morane	Vedrine
	gos	
May 26, 1911.....	Burgos to Madrid.....	Morane.....	Vedrine.....	140 miles	2:45:00
May 28, 1911.....	Voghera, Italy.....	Bleriot	Cirri	401 miles	13:35:00
May 28, 1911.....	Paris to Avignon.....	Bleriot	Roland Garros.....	1,300 miles
May 31, 1911.....	Paris to Rome.....	Bleriot	Andre Beaumont.....

*Corrections and Additions.

Sept. 7, 1909.....	Rome, Italy.....	Rossi	Enea Rossi.....
Dec. 6, 1909.....	Nice, France.....	Fernandez	Antonio Fernandez.....
Jan. 4, 1910.....	Bordeaux, France.....	Bleriot	Leon Delagrangé.....
Apr. 10, 1910.....	Marselles, France.....	Fabre	Fabre

INDEX

A

<i>Abbe Desforges</i>	120
Accessories	410
Acetylene	410, 413
Acetylene and Oxygen	416
Acetylene Burners	415
Acetylene Generators	414
Action and Reaction	194
Action, Radii of	436
Adams-Farwell Revolving Motor	129
<i>Ader, Clement</i>	120, 134, 140, 229, 392
Ader's Steam Aeroplane	134
Ader's Avion	151
Adjustable Ball Bearings	328
Aerial Experiment Association	154, 229, 360, 438
Aerial Metal	384
Aerial Navigation	446
Aerial Travel, Influence of Wind on	437
Aerial Travel Over Water	38
Aerial Vehicles, Design of	443
Aerial Vehicles, Applications of	428
Aerodynamics, Laws of	170
Aeronautic Society	450
Aeronautical Congress of 1893, Montgomery Paper Presented to	174
Aeronautical Development	23
Aeronautical Society of Great Britain	233
Aeronautical Terminology	464
Aeronautical Terms	464
Aeroplane Analogies	26
Aeroplane Details	158
Aeroplane, Fighting Utility of in War	37
Aeroplane, Framing	230
Aeroplane History	131
Aeroplane Most Promising	26
Aeroplane a Misnomer	26
Aeroplanes, Analogies in Nature	159
Aeroplanes, Balancing	215
Aeroplanes, Building and Testing	395
Aeroplanes, Efficient Modern	434
Aeroplanes, Typical	394
Air an Elastic Fluid	52
Air, Compressed	309
Air Cooling	290

Air in Advance of Surface, Effect of Surface Upon.....	172, 174
Air in Motion	50
Air, Liquid	50, 309
Air, Mobility of	63
Air, Properties of	49
Airships Versus Battleships.....	36
<i>Alexander</i>	120
Alighting and Starting	356
Alighting Gears	369
<i>Allard</i>	120
Alloy Steel	383
Alloys, Aluminum	384
Aluman	384, 393
Aluminum	393
Aluminum Alloys	384
Aluminum Bronze	386, 393
Aluminum Paint	388
Ammonia Gas	102
Anemometers	420
Aneroid Barometers	424
Angle of Incidence	204
Angle of Incidence, Effect of Excessive.....	204
Angle of Incidence, Proper Determination of.....	186
Animals and Aeroplanes, Flying.....	162
Animal Flight, Deductions from.....	159
Animal Oils	354
Annular Ball Bearings.....	33
Antoinette Monoplanes.....	31, 142, 155, 168, 208, 218, 312, 358, 396, 440
Antoinette Motors.....	85, 280, 289
Anzani Engines	280, 281, 398
Applewood	292, 375
Applications of Aerial Vehicles.....	428
<i>Archdeacon</i>	140, 153
Arc Lamps	411
Arcs of Circles.....	172
<i>Archytas</i>	118, 119
Argentallum	385
<i>Arlandes, Marquis d'</i>	70
<i>Artingstall</i>	120
Ash	375
Assembling	392
Atmosphere, Composition of.....	45, 46
Atmosphere, Extent of	43
Atmosphere, Height of	43, 44
Atmosphere, "Permanent Inversion Layer" in.....	55
Atmosphere, The "Homogeneous".....	43
Atmosphere, Tidal Currents in.....	58
Atmosphere, Weight of	43, 45
Atmospheric Electricity	64
Atmospheric Properties and Phenomena.....	43
Autogenous Welding	391
Automatic Equilibrium	221
Auxiliary Exhausts	297
<i>Avery, William</i>	136

B

Babbitt	343
"Baby," English Dirigible.....	83
<i>Bacqueville, Marquis de</i>	120
Balance, Lateral	215
Balancing Aeroplanes	215
Balancing by Dihedral Angle	216
Balancing by Vertical Surfaces	216
Balancing by Wing Warping	216
<i>Baldwin</i>	85, 120
Ball-Bearing Sizes, Capacities, and Weights.....	336
Ball Bearings	328
Ball Thrust Bearings	333
Ballast, First Use of.....	71
Ballast, Sand	109
Ballast, Water	109
Balloon An Evasion Rather Than Solution.....	24
Balloon Baskets	380
Balloon Duration Record	74
Balloon Envelope Materials	91
Balloon Envelopes, Sheet Metal.....	92
Balloon Fabrics, Cotton.....	93
Balloon Fabrics, Gas-proofing	95
Balloon Fabrics, Linen	94
Balloon Fabrics, Paper	94
Balloon Fabrics, Silk	93
Balloon, First Captive	70
Balloon, First Hydrogen.....	71
Balloon-height Control	106
Balloon Housings	115
Balloon Inflation	96
Balloon Landing Pits	116
Balloon Nettings	103
Balloon Valves	107
Balloons, Dirigible	76
Balloons, Early Chinese Ascensions with.....	66
Balloons, Heated-air	49
Balloons in Siege of Paris.....	74
Balloons, Internal	111
Balloons in War	73
Balloons, Limitations of	78
Balloons, Non-dirigible	66
Balloons, Non-lifting	107
Balloons, Soap Bubble	67
Balloons, Spherical	75
Balloons, Sounding	44
Balloons, Vacuum	67
Bamboo	375, 392
Bamboo, Split	375
Barometers	424
Barometers, Aneroid	424
Barometers, Mercurial	424
<i>Barton, Dr.</i>	83
Baskets, Balloon	380

Bats	165
Bats, Soaring	165
Bearings	327
Bearings, Adjustable Ball	328
Bearings, Annular Ball	330
Bearings, Ball	328
Bearings, Ball Thrust	333
Bearings, Cone	346
Bearings, Cylindrical Roller	340
Bearings, Flexible Roller	340
Bearings, Plain	342
Bearings, Roller	339
Bearings, Scraping Plain	345
Bearings, Tapered Roller	341
Beech	392
<i>Beedle</i>	83
<i>Bell, Alexander Graham</i>	137, 139, 153, 263
Belt, Link	317
Belts and Pulleys.....	324
<i>Berliner, Emil</i>	125
Berliner Helicopter	129
Berliner Helicopter, Data Concerning.....	130
<i>Berson</i>	75
<i>Berson and Süring</i>	44, 45
<i>Besnier</i>	120
Bevel Gears	322
Bicycle Analogies	39
<i>Bienvenu</i>	127
Biplane, Analogy with Box Kite.....	169
Biplanes	169
Birch	376, 392
<i>Black, Dr.</i>	67
Blade Outlines for Propellers.....	246
<i>Blanchard, Jean-Pierre</i>	72, 88, 120, 234, 442
Bleriot, Alighting Gear.....	370
Bleriot Machines, History of.....	135
<i>Bleriot, Louis</i>	30, 31, 119, 135, 153, 167, 168, 217, 241, 260, 281, 423
Bleriot Machines	207, 259, 312, 358, 396, 439, 440
Block Chains	316
Boat Convoys	38
Boat Paper	393
Body-Cradle Control.....	229
Boilers, Steam	301
Bolts	391
<i>Borelli</i>	120
<i>Bourcart</i>	120
Box Kite, Invention of.....	123
Box Tails	220
Boxwood	376-392
Braided Linen	393
Brass	392
Brasses and Bronzes	386
Brazing	391
Breakdown Not Inability.....	34
<i>Breant</i>	120

<i>Breary, F. W.</i>	233
<i>Breguet</i>	125
Breguet Helicopter-Aeroplane	130
British Aeronautical Exhibition.....	299
Bronze, Aluminum	386
Bronze, Phosphor	386
Bronzes and Brasses.....	386
Burners	303
Burners, Acetylene	415

C

Cable Chains	317, 319
Calcium, Carbide	413
Calcium Light	416
California Spruces	379, 392
California Vulture	159, 356
Carbon Steel	382
Castings	382
Cast Iron	384, 393
Castor Oil	353
Casualty Appraised by Horror Rather Than by Statistics.....	30
Carbureters	291
Catgut	389, 393
<i>Cavallo, Tiberius</i>	67
<i>Cavendish</i>	67, 98
<i>Cayley</i>	120
Cedar	392
Cements and Glues	390
Center of Gravity, Beneath Center of Pressure with Correct Surfaces at Correct Angles	213
Center of Pressure	184, 213
Center of Pressure, Forward Inclination of.....	190
Chains and Sprockets.....	314
Chains, Block	316
Chains, Cable	317, 319
Chains, Crossed	315
Chains, Lateral Flexibility in.....	316
Chains, Roller	317, 318
Chains, Silent	317
Chains, Standard American Roller.....	318
Change-speed Gear	314
Chanute Biplane	136
<i>Chanute, Octave</i>	22,
120, 136, 139, 140, 141, 142, 150, 155, 169, 218, 363, 398, 404,	451
Chanute Patent	462
<i>Charles, M.</i>	69, 71
Chauviere Propellers	241
Cherry	392
Chestnut	392
China Grass	390, 393
Cholski, Description of Wing Warping in 1881.....	217
Chord Angles	204
Chromaluminum	385, 393
Chrome-Nickel Steel	383

Chromlum	383
Chronometer	426
Cleared Areas, Necessity for in Starting and Allighting.....	366
<i>Clement-Bayard</i>	83, 157
Clips	391
Close-to-Ground Flight	30
Clutches	325
Cody Biplane	219, 259, 260, 314, 315, 399
<i>Cody, S. F.</i>	154
Coastal Winds	59
Coleoptera (Wing-case Insects).....	166
<i>Collier, M.</i>	153
Compass	422
Compound Movements in Controls.....	227
Compressed Air	309
Compressed Gas	109
Condor	160
Cone Bearings	346
Confined and Unconfined Air as Vehicle Support.....	29
Conservation of Energy, Relation of Law of to Soaring Flight.....	202
Construction and Materials.....	372
Continuous Rotating Mechanism Unknown in Animal Economy.....	26
Contents, Table of.....	7
Controlling Means	226
Cooling, Air	290
Cooling, Water	289
Copper	393
Cordage and Textiles	387
<i>Cornu</i>	125
<i>Cornu Helicopter</i>	129
Cost of Construction and Maintenance, Low.....	28
Cotton	388
Crossed Chains.....	315
Cups, Grease	352
Cups, Oil	349
Currents and Vortices	448
<i>Curtiss, Glenn H.</i>	22, 31, 154, 155, 169, 241, 448
<i>Curtiss Biplanes</i>	209, 229, 259, 358, 370, 400
Curvature of Wings.....	207
Curved Surfaces	172
Curved-Wing Aeroplanes	26
Cushions, Pneumatic	440
Cylinder of Rotation About Wing.....	187
Cylindrical Roller Bearings.....	340

D

<i>Daedalus and Icarus</i>	119
Daimler Motor	87
<i>Dandrieux</i>	120, 128
Danger of Flight.....	32, 33
<i>Danjard</i>	154
Deal	380
<i>Defolco</i>	143
<i>Degen</i>	120

<i>DeGroof</i>	120
<i>DeLabouret</i>	120
<i>Delagrange</i>	153
Dellwik-Fleischer Process for Producing Hydrogen.....	99
<i>DeLouvrie</i>	120
Demountability	437
Design of Aerial Vehicles.....	443
<i>D'Esterno, Count</i>	141, 146, 154
D'Esterno's Wing Warping.....	216
<i>Deutsch, M.</i>	82
Diameters, Propeller	250
Dihedral Angle	216
Dihedral Angle, Objection to.....	207
Dihedral Angles of Wings.....	207
Dirigibles, Effect of Size Upon.....	90
Dirigibles, Non-rigid	89
Dirigibles, Rigid	89
Dirigibles, Semi-rigid	89
Distance and Speed.....	420
Drag Ropes	110
Drift	210, 211
Dropped Weights	362
Drums, Winding	363

E

<i>Edison</i>	125, 128
Efficiencies of Aerial Propellers.....	253
Efficient Modern Aeroplanes.....	434
Elastic Bodies, Lack of Knowledge Concerning Laws of Motion of.....	195
Electric Lamps	411
Electric Lighting	411
Electric Motors	304
Electric Welding	391
Elevators	224
Elm	376, 392
Empire de l'Air, L'.....	156
Enamels	389
Energy, Question of Amount Required for Flight.....	192
Engine, Antoinette	280
Engine, Anzani	280, 281
Engine, Fiat	280
Engine Muffling	296
Engine, Naphtha	309
Engine, Renault	280
Engine, R. E. P.	281
Engines, Gasoline	277
Engines, Multicylinder Gasoline	277
Engines, Revolving Cylinder	282
Engines, Steam	299
Engines, V-shaped	280
English Channel, First Crossed by Balloon.....	72
Escape Valves for Balloons	107
Equilibrium, Automatic	221
Exchange of Momenta.....	195

Exploration and Prospecting.....	34
Express and Mail.....	433

F

Fabrics	388
Facing Wind in Starting and Allighting.....	367
Factors of Safety.....	30
Fan Blowers and Windmills.....	237
Farcot Machine	124
<i>Farman, Henry</i>	30, 153, 154, 169, 209, 221, 228, 241, 446, 474
Farman Biplanes	259, 358, 371, 404
Feathering Paddles for Propulsion.....	232
<i>Ferber, Captain Ferdinand</i>	140, 155
Ferber Biplane	208
Flat Engine	280
Fir, (New England Spruce).....	392
Fir, (Norway Spruce).....	329
First Commercial Applications of Flight.....	33
Fish, Flying	161
Flag, Waving of.....	179
Flapping Flight	159
Flat Surfaces	171
Flexible Roller Bearings.....	340
Flexible Rudders	224
Flight, Flapping.....	159
Flight of Wing-case Insects.....	159
Flight Records	473
Flight, Soaring	159
Flights, Tabular History of.....	476
Floats	359, 370
Fluids, Impact of Elastic.....	198
Fluid Movements, Nature of.....	175
Fluids, Rotations in.....	179
Flying Animals and Aeroplanes.....	162
Flying Animals, Size of.....	159
Flying Dragon	163
Flying Fish	161
Flying Frog	164
Flying High	446
Flying Lemur	163
Flying Low	447
Flying Machines Cheaper Than Motorcycles.....	29
Flying Squirrels	163
Flywheels	297
Folding Wings	438
Force and Motion	193
Forced Lubrication	350
Forms of Propeller Surfaces	244
Forms of Surfaces	169
Framing of Aeroplanes.....	230
<i>Franklin, Benjamin</i>	70
Freedom of Travel	40
French Walnut	378
<i>Frost</i>	120

Fuel Injection	293
Fuel Pumps	294
Fuels	303
Fuselage	439

G

Gain of Weights over Arcas.....	27
<i>Garnerin, Andre Jaques</i>	442
Gas, Compressed	109
Gas, Cost of.....	79
Gas, Leakage of.....	79
Gasoline Engines	277
Gasproofing Balloon Fabrics.....	95
<i>Gauchot</i>	147
Gear, Bleriot Alighting.....	370
Gears, Alighting	369
Gears and Shafts	320
Gears, Bevel	322
Gears, Spur	321
Generators, Acetylene	414
<i>Gibson</i>	120
<i>Gerard</i>	120
<i>Giffard, Henri</i>	80
<i>Glaisher and Cowell</i>	44, 56, 74
Glider, The Montgomery.....	173
Gliding Flight, Indefinite.....	231
Glue	393
Glues and Cements.....	390
<i>Godard, Louis</i>	84
Gores for Balloons	75
Grade Indicator	425
Graphite	344
Gravity Lubrication	349
Grease Cups	352
<i>Green</i>	120
<i>Gross</i>	75
Gross Dirigibles	83, 84
Gut, Silkworm	390
Gutta Percha	95
Gyroscope	222
Gyroscopic Action of Propellers.....	262

H

Hair	390
<i>Hammer, William J.</i>	450
"Hangars"	115
Hardwoods	374
Hargrave Clockwork Motors.....	123
<i>Hargrave, Laurence</i>	22, 122, 124, 155, 235, 236, 299
Hargrave Models	235
Hargrave Rubber-band Motors.....	123
Hargrave Steam Engine.....	122
Head Resistance, Effect of Rear Form Upon.....	215

Head Resistance, Lower to Unit Area of Small Surfaces.....	315
Head Resistances	210
Head Resistance, Effect of Projected Area Upon.....	213
Head Resistance, "Wind-cutting" Shapes of Little Value in Reducing....	213
Heating	441
Heavier-than-air Flying Machines.....	117
Heights Attained With Balloons.....	44
Helicopter	25, 125
Helicopter-Aeroplane	126, 130
Helicopter, Analogy With Aeroplane.....	131
Helicopter, Berliner	129
Helicopter, Cornu	129
Helicopter History	125
Helicopter Toys	127, 128
Helicopters in Nature.....	126
Helicopters, Lateral Progression of.....	130
Helium	102
Hemlock	377, 392
Hemp	393
Henson	22, 155
Hero	127
Herring, A. M.....	22, 136, 155
Hickory	377, 392
Hinged Wing Tips	217
Holly	378, 392
Hopkins	71
Horizontal Rudders	224, 225
Horn	393
Hot-tube Ignition	287
Housing	440
Human Hair	393
Hydroplane	316, 359

I

<i>Icarus</i>	119
Ignition by Heat of Compression.....	287
Ignition, Hot-tube	287
Ignition, Jump-spark	285
Ignition, Make-and-Break	284
Illuminating Gases	101
Impact of Elastic Bodies, Formula of.....	196
Impulse, Starting	360
Incandescent Lamps	412
Incandescent Mantles	416, 417
Incidence, Angle of.....	204
Inclined Surfaces	364
Indefinite Gliding Flight.....	231
Indicator, Grade	425
Influence of Wind on Aerial Travel.....	437
Insect Fliers	166
Insect Fliers, Largest.....	167
Internal Balloons	111
Iron	382
Iron (Commercial)	393

Iron (Pure Wrought).....	393
Ivory	393

J

Japans	389
Jay	120
Jeffries	72
Jets and Streams, Phenomena of.....	182
Jobert	120, 124
Jump-spark Ignition	285
"June Bug"	438, 439

K

Kaufman	120
Keith	120
Kerosene	355, 418
Knabenshue	85
Krupps	383

L

Lacquers	389
Lambert, Count de.....	474
Lamboley	120
Lamp, Nernst	413
Lamps, Arc	411
Lamps, Electric	411
Lamps, Incandescent	412
Lamps, Oil	411, 417
Lamps, Tungsten	412
Lana, Francis	67, 102
Lancewood	392
Langley Machines	207, 208, 260, 381, 404
Langley, Professor	23, 136, 275, 300, 359, 369
Langley's Law	212
Larch	392
Large Craft, Not Much Use for.....	27
Large Surfaces, Reason for Greater Sustention Per Unit of Area.....	184
Lateral Dimensions of Machines	206
Lateral Progression of Helicopters.....	130
Latham	31, 119, 396
Launching Aeroplanes Over Water	38
Launching From Height	368
Launching Vehicles	365
Launoy and Bienvenu	127
Law of Areas, Bulks, and Weights.....	27
Laws of Aerodynamics.....	170
Leather	393
Lebaudy Brothers	82
Lebaudy Dirigibles	83
LeBris, Captain	120, 146, 155, 216
Lift and Drift.....	210, 211
Lendenfeld	235

Level	425
Lever Controls	228
<i>Lecavasseur, M.</i>	155
"Liberte," French Dirigible.....	83
Light, Calcium	416
Lighter-than-air Machines	24, 25, 65
Lighting, Electric	411
Lighting Systems	410
Lights, Arrangement of.....	419
Lignum Vitæ	392
<i>Lilienthals</i>140, 147, 149, 151, 169, 172, 190, 218, 364, 404, 405, 451	
<i>Lilienthal, Gustav</i>	137
<i>Lilienthal, Otto</i>	137
Lilienthal Patent	463
Lilienthal's Tables	211
Limitations Expected	35
Linen	388
<i>Linsfeld</i>	155
Link Belts	317
Linseed Oil	95, 389
Liquid Air	50, 309
Locust	392
<i>Lome, Dupuy de</i>	80
Longitudinal Balance	220
Lorraine-Dietrich Motor	85
<i>Loubers</i>	442
<i>Loup, Michael</i>	156
Low Flying	447
Lubricants	352
Lubrication	347
Lubrication, Forced	350
Lubrication, Gravity	349
Lubrication, Splash	347
Luminous Paints	449

M

<i>McCurdy</i>	22
Magnallium	385, 393
Mahogany	378
Mahogany (Honduras)	392
Mahogany (Spanish)	392
Mail and Express	433
Make-and-break Ignition	284
<i>Maloney, Daniel</i>	138, 143, 144, 146
Maloney, Death of.....	145
Manila	393
Mantles, Incandescent	416, 417
Maple	378, 392
<i>Marey</i>	120, 235
Masses in Motion	194
Materials and Construction	372
Materials, Strength of.....	399
Maxim (Multiplane)	260, 404, 405
<i>Maxim, Hiram S.</i>	22, 128, 156, 258, 300, 358

<i>Meerwein</i>	120
Mercurial Barometers	424
Metals	381
Meteorology	53
Mineral Oils	352
Miscellaneous Controls	229
Miscellaneous Propelling Devices	231
Mobility of Air	63
Modification of End Sections.....	189
Moisture on Balloon Surfaces.....	112
Monoplanes, Greater Sustention of.....	167
<i>Montgolfiers</i>	68, 97, 127
Montgolfiers, First Experiment of.....	68
Montgomery Aeroplane	406
Montgomery, Flights in 1905.....	138, 139
Montgomery Glider	173, 407
<i>Montgomery, John J., Prof.</i>	22,
31, 138, 140, 141, 142, 146, 167, 168, 173, 181, 217, 221, 275, 368,	451
Montgomery Paper Presented at Aeronautical Congress of 1893.....	174
Montgomery Patent	457
<i>Moore</i>	120
"Motor" Account of Montgomery Flights.....	139
Motor, Anzani	398
Motor Standardization	28
Motors, Antoinette	85
Motors, Daimler	87
Motors, Electric	304
Motors, Lorraine-Deitrich	85
Motors, Spring	310
Motors, Vapor	309
<i>Mouillard, Louis Pierre</i>	141, 146, 156, 216, 451
Mouillard Patent	462
<i>Moy, Thomas</i>	156
Muffling Engines	296
Multicylinder Gasoline Engines.....	277
Multiplanes	168
<i>Murrell</i>	120
Muslins for Balloon Envelopes	93
Multibladed Propellers	248

N

Nalls	390
Naphtha Engine	309
<i>Napter</i>	120
Nature's Mechanisms	25
Navigation, Aerial	446
Nernst Lamp	413
Nettings, Balloon	103
<i>Newcomb, Simon</i>	160
News Service	434
Nickel-Aluminum	385, 393
Nickel	383
Non-lifting Balloons	107
Normal Resistance of Surfaces.....	211

"Normally-Flat" Surfaces of Wright Patent.....	455
<i>Normand, M. Le</i>	442
Norway and California Spruces.....	379
Norway Spruces.....	379

O

Oak	378
Oak, English	392
Oak, Live	392
Oak, White	392
Oil	389
Oil, Castor	353
Oil Cups	349
Oil Lamps	411, 417
Oil, Linseed	389
Oil, Olive	353
Oil, Sperm	354, 417
Oilers, Ring and Chain.....	348
Oils, Animal	354
Oils, Mineral	352
Oils, Vegetable	353
Olive Oil	353
Open Balloon Necks.....	110
Oregon Pine	392
Ornithopter	25, 118
Ornithopter History	118
Orthogonal Flight	120
Osculatory Circles of Parabola.....	181
Osier	380
Oxygen and Acetylene.....	416

P

Paint, Aluminum	388
Paints and Varnishes	388
Paints, Luminous	449
<i>Palmer</i>	120
Panhard Motors	280, 289
Parabola, Correct Section for Sustaining Surfaces.....	180
Parabola, Osculatory Circles of.....	181
Parabola, Relations of Focal Lengths to Chord Lengths.....	191
Parabola, Study of.....	181
Parabolic Sections in Propellers.....	245
Parabolic Surfaces	173
Parabolic Surfaces, Compound Effects of.....	183
Parabolic Surfaces, Reflection of Impulses Beneath.....	182
Paraboloid Reflectors	419
Parachutes	442
Parseval Dirigibles	83, 84
Partinium	385, 393
Passenger Accommodation	439
Patent, Chanute	462
Patent, Lillenthal	463
Patent, Montgomery	457
Patent, Mouillard	462
Patent, Wright	451
Patents	451

Pearwood	392
Pedal Controls	229
Pellerie, Robert Esnault.....	154, 167, 228, 258, 259, 408
Penaud, A.....	120, 124, 127, 146, 147
Percales for Balloon Envelopes.....	93
Peripheral Speeds of Propellers.....	250
Pettigrew	120
Phillips, Horatio	157, 168, 173
Phillips, W. H.....	127
Phosphor Bronze	386
Pichancourt	120, 124
Pilcher, Percy S.....	22, 147, 218, 404, 407
Pines	379
Pine, Pitch	392
Pine, Red	392
Pine, White	392
Pine, Yellow	392
Pivoted Rudders	224
Placing of Propellers.....	258
Plain Bearings	342
Plane Placed at Angle to Stream.....	179
Plumwood	392
Plural Carrying Surfaces.....	221
Plural Propellers	259
Plural Wing Tips	220
Plurality of Operators	227
Pneumatic Cushlons	440
Poplar	379, 392
Power Plants	273
Practical Utility	39
Pressure Above Surfaces	187
Priestly	68
Prigent	120
Progress Against Wind	27
"Progress in Flying Machines," Book.....	120, 121
"Progress in Flying Machines," Account of Early Montgomery Work in..	142
Projected Area, Effect Upon Head Resistances.....	213
Propeller Analogies	237
Propeller-Blade Arrangements.....	252
Propeller-Blade Outlines	246
Propeller Blocks	267
Propeller Diameters	250
Propeller-driving Arrangements	313
Propeller Efficiencies	253
Propeller, Effective Surface of.....	241
Propeller Materials	264
Propeller Pitch and Blade Angles.....	242
Propeller Placings	258
Propeller Surfaces, Forms of.....	244
Propeller Thrust	361
Propeller, Typical	270
Propellers, Gyroscopic Action of.....	262
Propellers, Multibladed	248
Propellers, Peripheral Speeds of.....	250
Propellers, Plural	259

Propellers, Single	259
Propellers, Two-bladed	249
Propulsion	231
Pterodactyl	160, 165
Pulleys and Belts.....	324
Pumps, Fuel	294

Q

<i>Quartermain</i>	120
Questions of Safety.....	29
<i>Quinby</i>	120

R

Radli of Action	436
Radli of Action Possible to Secure	27
Rail Launching Devices.....	359
Rapid Transit, Secret of All	28
Rattan	105
Rawhide	390, 393
Reaction Turbines	127
Reciprocating-wing Systems	25
Reciprocating Wings	234
Records, Flight	473
Reflectors	418
Reflectors, Paraboloid	419
<i>Renard</i>	82, 128
Renault Engine	280, 291
R. E. P. Engine.....	281
R. E. P. Monoplanes.....	31, 226, 358, 408, 440
"Republique," French Dirigible	83, 84
Resultants Beneath Surfaces	181
Revolution Counters	422
Revolving-Cylinder Engines	282
Reversible Sprockets	319
<i>Richet</i>	120
Ring and Chain Ollers.....	348
Rip Cords	108
<i>Rittenhouse</i>	71
Rivets	391
<i>Robert</i>	69, 71
Rocket Schemes	310
Rocking Wings	288
Roller Bearings	339
Roller Chains	317, 318
<i>Romaine, M.</i>	72
Rotating-wing System	25
Rotations in Fluids	179
<i>Rozier, Pilatre de</i>	70
<i>Rozier, Pilatre de, Death of</i>	72
Rubber	95
Rudders, Flexible	224
Rudders, Front	220
Rudders, Horizontal	224, 225

Rudders, Pivoted	224
Rudders, Rear	220
Rudders, Twisting	225
Rudders, Vertical	224
Runners	360, 370

S

<i>Saint-Fond, M. Faujas de</i>	69
<i>Saint Victor, Castillon de</i>	74
<i>Santos-Dumont, Alberto</i>	82, 104, 140, 148, 229, 261, 408
Santos-Dumont Machines	208, 358
<i>Shaeck</i>	74
"Scientific American," Account of Montgomery Flights	139
"Scientific American Supplement," Description of Wing-warping in 1881 ..	217
Scraping Plain Bearings	345
Screw Propellers	236
Screws	391
Shafts	320
Shoulder-Fork Control	229
Seats	440
Sections of Sustaining Surfaces	171
<i>Selfridge, Lieutenant</i>	259
Semi-Parabola	180
<i>Serero, Auguste</i>	104, 107
Shafts and Gears	320
Shellac	389
Shifting Weight	218, 221
Siemens, Electric Motor	81
Signals	449
Silent Chains	317
Silk	388, 393
Silk Cord	390
Silkworm Gut	390, 393
Single Propellers	259
Size of Flying Animals	159
Sizes of Machines	27
Skin Friction	210
Skin Friction of Propellers	257
Slip in Propellers	243, 244
Small-unit Vehicle Ideal	28
Smeaton's Tables	211
<i>Smyth</i>	120
Soaring Bats	165
Soaring Birds	164
Soaring, Explanation of	200
Soaring Flight	159
Soaring in Calm Air	274
Soaring, Phenomena of	192
Sockets, Strut	386, 387
Softwoods	379
Soldering	392
Sounding Balloons	44
Spar Varnish	389
Speed and Distance	420

Speed and Flying Radius	26
Speed, Effect Upon Sustentation.....	212
Speed of Aerial Travel.....	27
Speed of Reciprocation With Wings.....	235
Speeds, Maximum and Average.....	27
Speeds of Land Travel.....	38
Speeds Ultimately to be Attained.....	26
Spencer	83
Sperm Oil	354, 417
Splash Lubrication	347
Split Bamboo	375
Sport	432
Spring Motors	310
Sprockets and Chains.....	314
Sprockets, Reversible	319
Spruce	379, 392
Spruces, Norway and California.....	379
Spur-gear Drives	321
Spur Gears	321
Squirrels, Flying	163
Standard American Roller Chains.....	318
Starting and Alighting.....	356
Starting Devices	357
Starting Impulse	360
Steam Bollers	301
Steam Engines	299
Steam Engines, Hargrave	122
Steel	382
Steel, Cast	393
Steel, Malleable Castings	393
Steel, Common Plano Wire.....	393
Steel, Tinned Plano Wire.....	393
Steel Alloy	383
Steel, Carbon	382
Steel, Chrome-Nickel	383
Steering Aeroplanes	223
Steering Balloons	113
Steering Balloons by Drag Ropes.....	114
Steering, Effect of Propellers on.....	262
<i>Stevens</i>	85
Straight Pitch in Propellers	241
Strength of Materials	398
<i>Stringfellow</i>	22, 157, 299
Structure, Always a Visible and Invisble.....	214
Strut Sockets	386, 387
<i>Struve and Teleschiff</i>	120
Surface Moving a Fluid.....	178
Surface, "Normal" Resistance of.....	211
Surfaces, Arrangement of	205
Surfaces, Circular Arcs.....	172
Surfaces, Design of Tandem.....	191
Surfaces, Forms of.....	169
Surfaces, Inclined	364
Surfaces, Parabolic	173
Surfaces, Pressure Above	187

Surfaces, Proper Form and Adjustment.....	180
Surfaces, Staggered	205
Surfaces, Superposed	205
Surfaces Sustaining, Values of Different.....	210
<i>Süring</i>	75
Sustaining Force, Forward Inclination of.....	211
Sustaining Surfaces as Continuous Wings.....	206
Sustaining Surfaces as Separate Wings.....	206
Sustaining Surfaces, Sections of.....	171
Sustention, Effect of Adjacent Surfaces Upon.....	212
Sustention, Effect of Change of Outline Upon.....	212
Sustention, Increase With Speed.....	212
<i>Sutton</i>	120
Swinging Wing Tips	219
Sycamore	392

T

Table of Contents.....	7
Tables of Wind Pressures.....	214
Tables, Lillenthal's	211
Tables, Smeaton's	211
Tabular Comparison of Flying Animals and Aeroplanes.....	162
Tabular History of Flights.....	480
Tails, Box	220
Tallow	354
Tandem Propellers	263
Tandem Surfaces	191
Tangential	190, 211
Tanks	310
Tapered Roller Bearings	341
<i>Tatin, Victor</i>	120, 157
Teak	392
Technique of Aerial Navigation	41
Temperature, Effects of on Balloons.....	112
Terminology, Aeronautical	464
Terms, Aeronautical	464
Terrestrial Adjuncts	449
Textiles and Cordage	387
Thermopile	307
Things Possible but not Profitable.....	29
Three Traversable Media	24
Thrust Propeller	361
Tilting Wing Tips	217
<i>Tissandier, Gaston and Albert</i>	81, 305, 307
Toy Helicopters	127, 128
Trade Winds	60
Transaqtatic Mail Lines	38
Transmission Elements	313
Transportation Never Unlimitedly Flexible	35
Triplanes	
<i>Trouvé</i>	121, 124
Trouvé Electric Motor	305
Tungsten	383
Tungsten Lamps	412

Turnbuckles	386, 387
Twisting Rudders	225
Two-Bladed Propellers	249
Types to Survive.....	24
Typical Aeroplanes	394
Typical Propellers	270

U

United States Weather Bureau.....	450
Uranium	383

V

Vacuum Balloons	67
Valves, Balloon	107
Vanadium	383
Vanes, Wind	425
<i>Vantman, Melvin</i>	84
Vaniman Triplane	169
Vapor Motors	309
Variable Wing Areas	218
Varnishes and Paints	388
Vaseline	352
<i>Vault, Henry de La</i>	74
Vegetable Oils	353
Vehicles, Applications of Aerial.....	428
Veneers and Bendings	380
"Venetian-blind" Constructions	168
Vertical Rudders	224
Vertical Surfaces for Balancing.....	216
Vertical Surfaces in Nature's Fliers.....	163
Vertical Surfaces, Rare in Nature.....	209
Victoria Aluminum	385
"Ville de Nancy," French Dirigible.....	83
<i>Vinci, Leonardo da</i>	120, 126
Visible and Invisible Structure of Machine.....	214
Voisin and Curtiss Machines.....	227
Voisin-Farman Triplane	169
<i>Voisin, Gabriel</i>	31, 123, 140, 153, 169, 221
Voisin Biplanes	154, 209, 321, 358, 367, 409
Vortices and Currents	448
V-Shaped Engines	280
<i>Vuia</i>	157
Vulcanized Fiber	344
Vulture of California, Largest Soaring Bird.....	159

W

Walnut	378
Walnut Black	392
Walnut Hickory	392
Walnut French	378
Warfare	429
Water Cooling	289

Wave Lines in Fluids.....	178
Wave Surfaces for Propulsion.....	233
Weights, Dropped	362
Weiss	221
Welding, Autogenous.....	391
Welding, Electric.....	391
Wellman, Walter	84
Wenham, F. H.....	22, 168
Wenham, F. H., <i>First Suggestion of Multiplane</i>	149
Whalebone	393
Wheel Controls	228
Wheeler	120
Wilcox, James	71
Wilkie	143, 144
Willow	380, 392
Winding Drums	363
Windmills and Fan Blowers.....	237
Wind Pressures, Tables of.....	214
Wind Vanes	425
Wind Velocities	62
Wing Outlines	204
Wing Surfaces	189
Wing Surfaces, Modification of End Sections.....	203
Wing Tips, Hinged.....	217
Wing Tips, Plural.....	220
Wing Tips, Swinging.....	219
Wing Tips, Tilting.....	217
Wing Warping, Early Use of.....	216, 217
Wing Warping for Balancing.....	216
Wings, Continuous	206
Wings, Dihedral Angle of.....	207
Wings, Folding	438
Wings, Lateral Curvature of.....	207
Wings, Reciprocating	234
Wings, Separate	206
Wings, Speed of Reciprocation with.....	235
Wire	281, 386
Wire Tightener	387
Wise, John	74
Wolframium	385, 386
Wolframium, in <i>Zeppelin Dirigible</i>	87
Wood	105, 373
Wright	254, 289
Wright Brothers, <i>Wilbur and Orville</i>	149, 425, 451
Wright Machines.. 209, 227, 259, 260, 262, 275, 280, 312, 314, 315, 359, 361, 362, 388, 399, 409, 474	
Wright Machines, Vertical Surfaces in Elevator of.....	210
Wright Machines, Wings Drooped in.....	207
Wright, Orville	152, 259
Wright Patent	152, 451
Wright Patent, "Normally Flat" Surfaces of.....	455
Wrights.. 22, 30, 140, 150, 169, 190, 217, 218, 224, 228, 229, 360, 364, 365, 371	
Wright Starting Device.....	362
Wright, Wilbur	152, 261

Y

Yamada, Isaburo 84
Yew 392

Z

Zeppelin 85, 386
Zeppelin Dirigibles 86, 88, 90
Zeppelin Envelope Material 92

14 DAY USE
RETURN TO DESK FROM WHICH BORROWED
LOAN DEPT.

This book is due on the last date stamped below, or on the date to which renewed.
Renewed books are subject to immediate recall.

OCT 29 '67 - 1 PM

LOAN DEPT.

NOV 17 1967 34

REC'D

DEC 11 '67 - 11 AM

LOAN DEPT.

APR 4 1982

REC'D MAR 16 1982

LD 21A-60m-2,'67
(H241s10)476B

General Library
University of California
Berkeley

MAY 10 1960 OCT 4 '67 - 2 PM

LOAN DEPT.

LD 21-100m-2,'55
(B139s22)476

OCT 18 1966
General Library
University of California
Berkeley

YD 18121

21

1892

1892

