

630.7
I l 6b
no.611
cop.8

UNIVERSITY OF
ILLINOIS LIBRARY
AT URBANA-CHAMPAIGN
~~BOOKSTACKS~~

630.1
I866
no. 611
cop. 8

A VIBRATOR-POWERED METER For Small Grain and Ground Feed

By H. B. Puckett and Robert M. Peart

This vibrator feed meter feeds oats into an auger which delivers ingredients to an automatic feed grinder. The voltage controller on the right is one means of adjusting flow and the sliding gate is another. The vibrator meter is fed by an overhead bin-supply spout.



AGRICULTURE LIBRARY

JAN 23 1950

UNIVERSITY OF ILLINOIS

UNIVERSITY OF ILLINOIS · AGRICULTURAL EXPERIMENT STATION

In cooperation with the U. S. DEPARTMENT OF AGRICULTURE

TWO OR MORE FEED METERS, operating together and with their outputs proportioned, constitute a feed blender. The blender is an essential part of an automatic feed grinding system (Fig. 1). The principle of this automatic system is to grind a mixed ration rather than to blend a ground one. Grains and supplements are continuously metered in the desired proportion into a grinder which does an excellent job of mixing while it is grinding. A complete automatic feeding system includes: (1) bins; (2) blender;

(3) grinder; (4) conveyor; and (5) distributor (such as a bunk feeder or self-feeder).

A feed meter is also necessary when silage and concentrates are mixed and distributed by a mechanical bunk feeder. The silo unloader delivers silage uniformly to the feeder and at the same time the feed meter applies the concentrate at the desired rate. The feed meter insures that the added material is uniformly distributed and that each animal has an opportunity to eat the proper amount of silage and supplement. The feed meter saves expensive feeds and takes much less of the operator's time. A silage distributing system with a vibrator meter installed to apply the supplement



Five vibrator feed meters are used here to deliver shelled corn, oats, and different supplements in the desired proportion to an automatic 5-horsepower electric hammer mill. (Only three can be seen in the picture.) This grinder includes an ear corn drag, which removes and meters ear corn, and a complete automatic control which regulates the feeding rate and stops the grinder at the end of the desired time period or when there is mechanical trouble. (Fig. 1)

is shown in Fig. 2. A feed meter is useful for any job of applying a granular material at a uniform rate — for instance, feeding ground corn into legume silage at the silo filler. An automatic timer on a feed meter will turn the meter off at the right time so that the desired total amount of feed is delivered to a wagon, truck, or feeder.

A vibrator-powered meter has been developed which has a low first cost, is simple to construct, and has long life. It is powered by 120V 60-cycle current, has no rotating parts, and requires no lubrication. The meter consists of a metal box with an apron and a 60-cycle solenoid vibrator attached to the bottom (see cover picture). Output is regulated by a gate which controls the amount of feed on the apron, and by a rheostat which adjusts the coil voltage and the amplitude of vibration. The meter output may also be regulated by adjusting the air-gap spacing of the vibrator. Decreasing the air gap minimizes the effects of voltage changes at the higher values of voltage and is useful if the discharge rate is to be controlled by adjusting the gate and if the vibrator is connected directly to the 120V 60-cycle supply. Under these conditions, normal line voltage fluctuations have small effect on the meter output.

The output of a vibrator-type meter is dependent upon several factors which must be held constant to achieve satisfactory performance. They are:

1. Amplitude of vibration
 - a. coil voltage
 - b. air-gap spacing
 - c. resonance frequency of meter box (size and thickness of material in box)
2. Angle of repose of material
3. Height of gate
4. Length of apron from gate
5. Angle of meter bottom (vibrating member) with the horizontal
6. Width of apron

Most of the above factors are fixed in design and installation. Voltage, air-gap spacing, and gate adjustment are left variable to adapt the meter for each installation.

Several meter designs were tested. The one shown on the cover was chosen, because it gave the greatest range in metering



The top half of this barrel is a hopper for ground feed. A vibrator-type feed meter in the bottom half delivers the feed at the correct rate to the push-pull type bunk feeder. (Fig. 2)

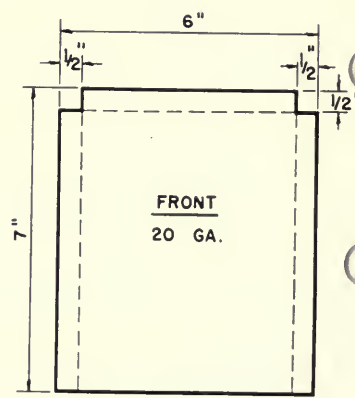
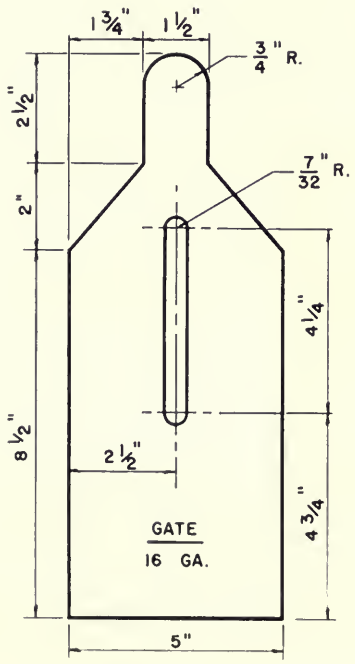
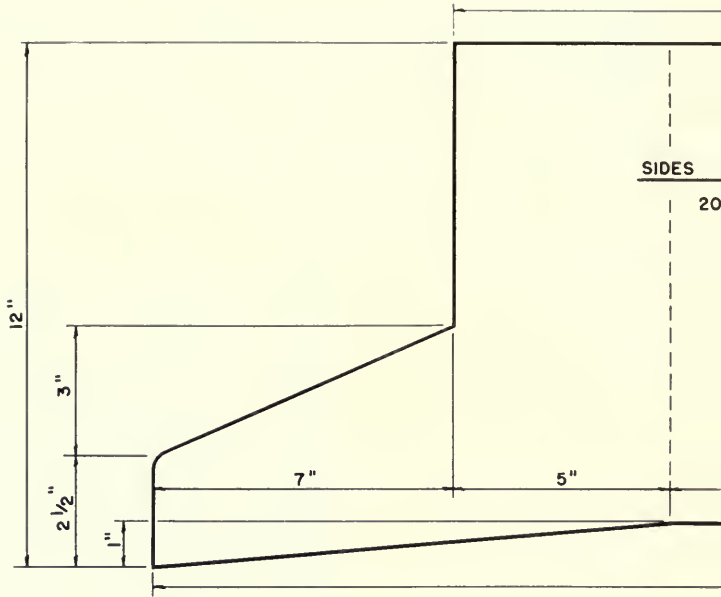

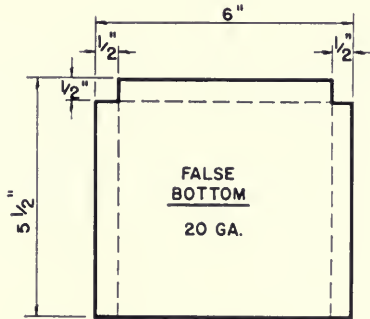
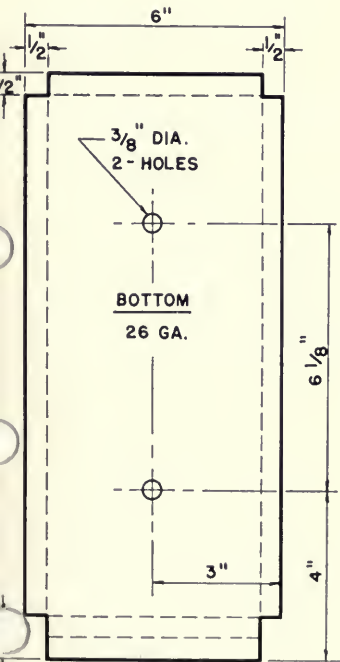
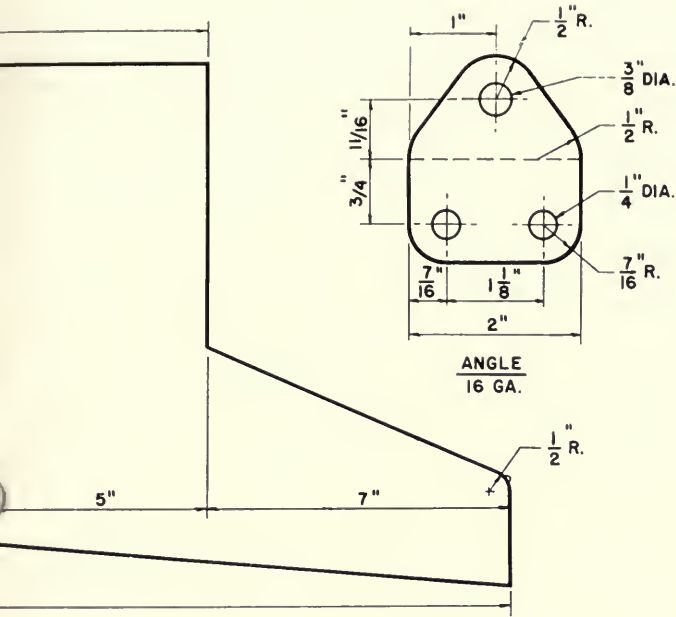

--- BEND LINES

with the highest accuracy. The predicted limit of error for this meter is 5 percent at capacities of 2 to 30 pounds per minute. (For the effect of gate opening and coil voltage on meter output, see Fig. 4.) Voltage and gate opening are independent in their effects on meter output.

The sides of the vibrator meter are made of heavy galvanized steel (20 gage) to reduce their tendency to vibrate, whereas the bottom is made of lightweight steel (26 gage) so that it vibrates easily with the basic frequency of the vibrator (7200 vibrations or pulses per minute).

The bottom of the meter is sloped 5° below the horizontal so that the vibrator motion, which is perpendicular to the meter bottom, will advance the feed on the meter apron toward the outlet with each pulse. The false bottom of the meter lessens the load on the vibrating member so that it vibrates easily and more uniformly. It also reduces the tendency of feed to pack in the meter box, and in some instances, the delivery pipe. The meter should always be mounted with the sides and back perpendicular to the horizontal.

Each meter should be calibrated after it is installed and calibrated for each new batch of feed. Variation in mounting will change its output. Feed-stuffs vary in content of fine materials and in some cases in the amount of foreign material. These variations will affect the output of the meter. Make final calibration of a meter after it has operated 30 to 60 minutes. The feed will polish the metal surfaces in this "break-in" period. After they have been polished, the flow of feed will stabilize.

This meter can be easily and quickly constructed by anyone with the proper tools and experience in sheet metal work. Construction drawings are given in Figs. 3 and 5. Bend all lap joints 90° and make the joint with the lap strip on the inside. Spot welding, if available, is the most convenient way of fastening the joints. Rivets or sheet metal screws with soldered joints can be used. The connection must be rugged to withstand the vibration. Secure the heads of vibrator mounting bolts by spot welding or soldering them to the sheet metal. Spot welding or soldering the bolts makes it easy to attach the vibrator and to adjust the gate. Attaching a 4-inch section of a steel ruler to the gate and a pointer on the main frame provides an easy means of calibrating the meter.

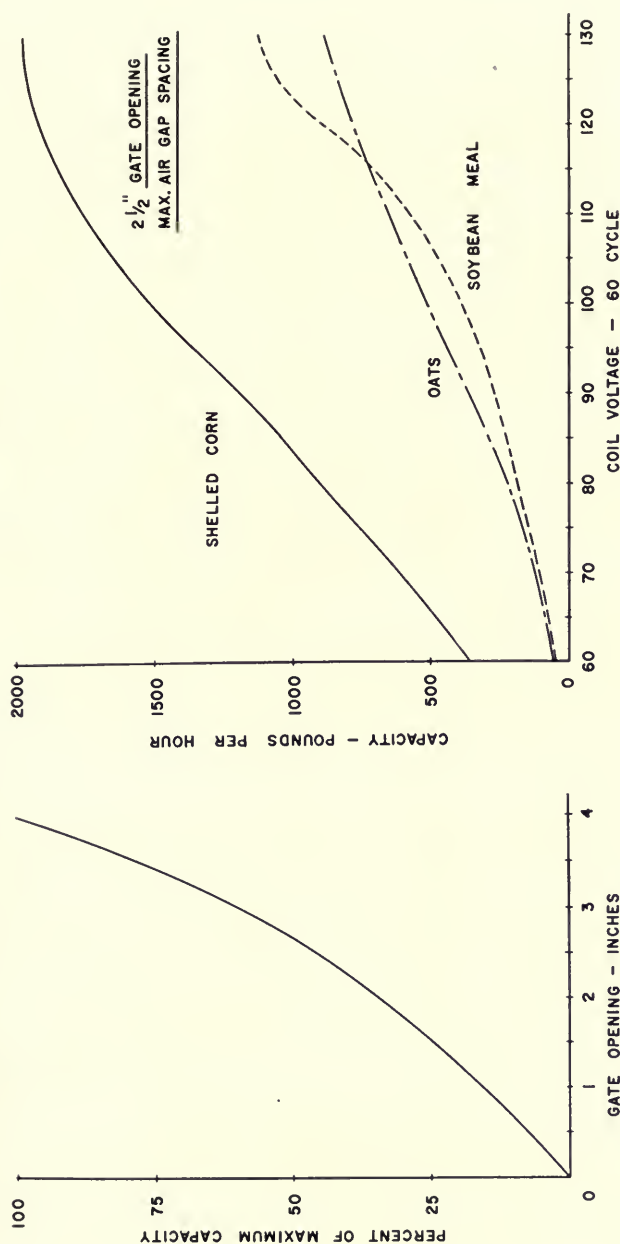

The meter output at various gate openings with constant coil voltage is directly proportional to the percent of maximum capacity for the gate openings as shown in the graph on the left. For example, 540 pounds of soybean meal per hour are metered through a $2\frac{1}{2}$ -inch gate opening at 110 volts (see graph on right). This rate is 45 percent of maximum capacity (see graph on left). If the voltage remains at 110 and the gate opening is decreased to 1 inch, the new rate will be 16 percent of the maximum capacity. Therefore, $\frac{540}{45} = \frac{\text{new rate}}{16}$, or 192 pounds per hour.

(Fig. 4)

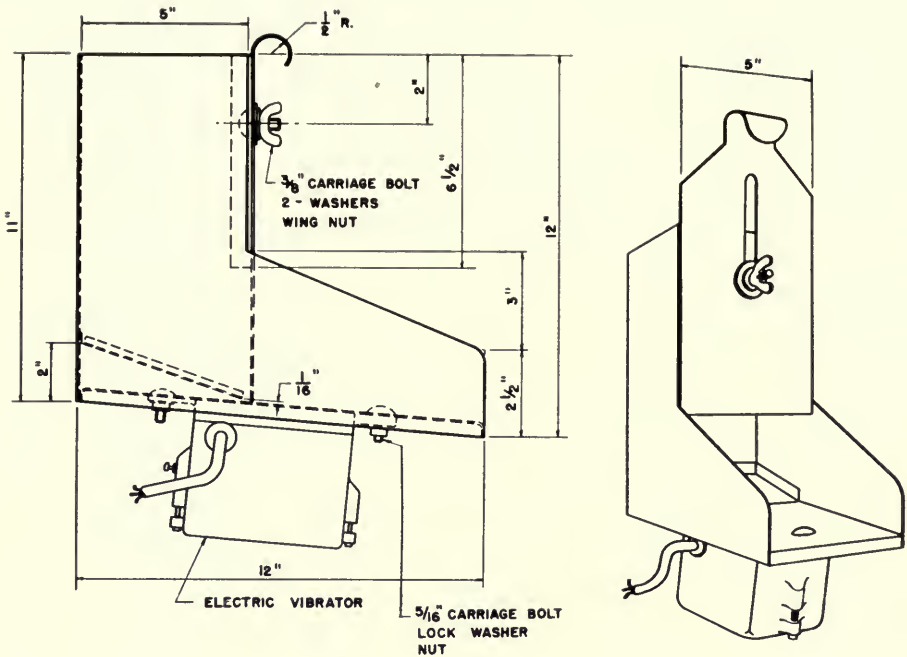

This feed meter was developed as part of a cooperative research program between the Agricultural Engineering Department of the University of Illinois Agricultural Experiment Station and the Agricultural Research Service, U. S. Department of Agriculture.

Experiment Station funds for the work were provided in part by the Illinois Farm Electrification Council, a group whose activities involve the application of electricity to agriculture. Electric power suppliers, serving 97 percent of Illinois farmers, are active in the Council.

This bulletin reports research conducted by H. B. Puckett, Agricultural Engineer, Agricultural Engineering Research Division, Agricultural Research Service, U. S. Department of Agriculture, and Robert M. Peart, Research Associate, Agricultural Engineering Department, University of Illinois.





UNIVERSITY OF ILLINOIS-URBANA

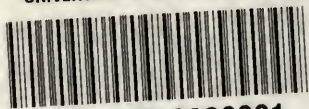

3 0112 018398831