

UC-NRLF



5C 55 157

WE and OUR GOVERNMENT



JEREMIAH W HIPPLE JENKS
RUFUS DANIEL SMITH

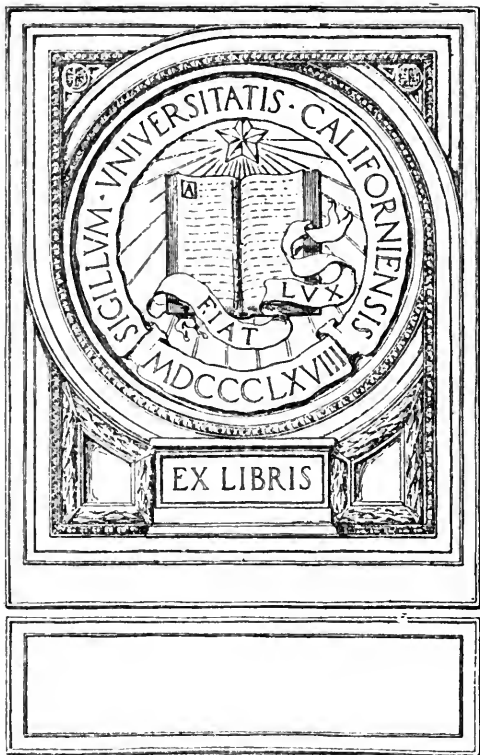

EX LIBRIS

Digitized by the Internet Archive
in 2008 with funding from
Microsoft Corporation

"Let the people know the truth, and the country is safe."—Lincoln

WE AND OUR GOVERNMENT

By

JEREMIAH WHIPPLE JENKS

Research Professor of Government and Public Administration
New York University

and

RUFUS DANIEL SMITH

Associate Professor of Public Economy, New York University

With fourteen full page drawings by Hanson Booth, and over
five hundred halftone and line illustrations



DONALD F. STEWART

Editor

The text of this book has been read and approved by an Editorial Advisory Board composed of many of the leading educators of the whole country. The book is published in cooperation with Federal Educational Activities

New York
The American Viewpoint Society
a department of
Boni & Liveright, Inc.
1922

TO THE
ADMINISTRATIVE

JK 274
J4

WE AND OUR GOVERNMENT

Copyright, 1922, by

Boni & Liveright, Inc.

All rights protected including the Scandinavian

FORT ORANGE PRESS
THE BRANDOW PRINTING COMPANY
ALBANY, NEW YORK

AUTHORS' FOREWORD

HE Government of the United States must be carried on by intelligent American citizens who have a grasp of the fundamental principles underlying its organization and activities. The purpose of this first volume of The American Viewpoint Series, "We and Our Government," is to state and discuss these principles simply and concisely. The main emphasis throughout the book is placed on ideas vital to an understanding of the actual workings of our Government rather than on a purely encyclopedic statement of detailed activities which change so rapidly from day to day.

The authors are indebted to the Editor of the Series, who, with infinite patience and skill, has re-expressed in pictures and captions the text of the book. These illustrations (there are over 500), with their captions, make in themselves a simplified and concise text emphasizing the outstanding points in each chapter much in the same manner as a moving picture develops its theme. In fact the reader has really three connected narratives: First, pictures; second, captions, and third, text.

Educators who have examined the first volume have expressed the opinion that this original plan of illustration makes it for all an exceptionally easy, interesting, and helpful book to read.

The authors will indeed be satisfied if "We and Our Government" meets the need so often expressed to them by teachers and students for a book which would explain clearly and simply how our Government works and the principles upon which it is built. If it arouses in its readers a desire to take a greater interest in our country and its problems; to know more of its resources, its economics and its people, then those who are responsible for it will be richly rewarded.

The authors are greatly indebted to the members of the Editorial Advisory Board of the American Viewpoint Society for their valuable cooperation in the preparation of the text of this book, also, to Raymond F. Crist of the Bureau of Naturalization, Department of Labor, Washington, for his editorial assistance in the preparation of the text of Chapter V—American Citizenship.

J. W. J.
R. D. S.

THE EDITORIAL ADVISORY BOARD OF THE AMERICAN VIEWPOINT SOCIETY

DONALD F. STEWART
President and Editor
HORACE B. LIVERIGHT
Chairman of Executive Board

EDITORIAL ADVISORY BOARD

- FANNIE FERN ANDREWS
Secretary, The American School
Citizenship League
- ANNIE WEBB BLANTON
State Superintendent of Public
Instruction, Texas
- EDWIN C. BROOME
Superintendent of Schools,
Philadelphia
- ARTHUR H. CHAMBERLAIN
Executive Secretary, California
Council of Education
- J. A. C. CHANDLER
President, College of William
and Mary
- FRANK CODY
Superintendent of Schools,
Detroit
- L. D. COFFMAN
President, the University of Min-
nesota
- WILLIAM M. DAVIDSON
Superintendent of Schools,
Pittsburgh
- ARTHUR D. DEAN
Professor of Vocational Educa-
tion, Teachers College, Columbia
University
- FRANK L. DYKEMA
Executive Secretary of the
Americanization Society,
Grand Rapids
- F. E. FINEGAN
State Superintendent of Public
Instruction, Harrisburg
- EUGENE LYMAN FISK, M. D.
Vice President and Medical Di-
rector, Life Extension Institute
- ALBERT BUSHNELL HART
Professor of Government in Har-
vard University
- GRACE RAYMOND HEBARD
Professor of Economics and So-
ciology, University of Wyoming
- H. V. HOLLOWAY
Commissioner of Education, State
of Delaware
- JEREMIAH W. JENKS
Research Professor of Govern-
ment and Public Administration,
New York University
- JOSEPH FRENCH JOHNSON
President, Alexander Hamilton
Institute; Dean and Professor of
Political Economy, New York
University
- R. G. JONES
Superintendent of Schools,
Cleveland, Ohio
- HON. BEN B. LINDSEY
Judge of the Juvenile Court,
Denver
- ORTON LOWE
Director of English, Department
of Public Instruction,
Pennsylvania
- JOHN J. MAHONEY
Professor of Education, Boston
University, and Director of
Extension Courses for Boston
University, and the Harvard
Graduate School of Education.
- WILLIAM McANDREW
Associate Superintendent, New
York Public Schools
- I. B. MORGAN
Director of Continuation,
Schools and Vocation Bureau,
Kansas City, Kansas
- PETER A. MORTENSON
Superintendent of Schools,
Chicago
- ANGELO PATRI
Principal of Public School No.
45, New York City
- FRANCES PERKINS
Secretary, Council of
Immigrant Education, New York
- JOSEPHINE CORLISS PRESTON
Superintendent of Public Instruc-
tion, State of Washington
- GEORGE F. QUIMBY
Industrial Service Secretary, As-
sociated Industries of Massachu-
setts
- PHILIP SHORE
Chairman Board of Education,
Tampa, Fla.
- RUFUS DANIEL SMITH
Associate Professor of Public
Economy, New York University
- WILLIAM C. SMITH
Supervisor of Immigrant Educa-
tion, The University of the State
of New York
- CORA WILSON STEWART
Chairman, National Illiteracy
Committee, Frankfort, Ky.
- ASHLEY H. THORNDIKE
Professor of English, Columbia
University
- JAMES E. WEST
Chief Scout Executive,
Boy Scouts of America
- ARTHUR H. WILDE
Dean, School of Education,
Boston University
- WILL C. WOOD
Superintendent of Public Instruc-
tion, California

SUBJECTS CHOSEN FOR THE SERIES OF CITIZENSHIP BOOKS BY THE EDITORIAL ADVISORY BOARD

- (1) POLITICAL:—3 Books
a *We and Our Government
b *History of the United States
c *We and Our Neighbors
- (2) NATURAL RESOURCES:—2 Books
a Our Treasures of Land and Sea
b The Mighty Commerce of the Nation
- (3) POPULATION:—1 Book
*Who and What Are We?
- (4) BUSINESS RELATIONS:—1 Book
*We and Our Work
- (5) SOCIAL RELATIONS:—3 Books
a *Public and Personal Health
b *The American—Author, Artist, Builder
c *To Learn—Where and How

NOTE.—The titles of the books are not given—subject matter only. Asterisk (*) indicates subjects for which authors have been secured.

A PARTIAL LIST OF AMERICAN VIEWPOINT AUTHORS

- JEREMIAH WHIPPLE JENKS, Ph. D., LL. D., Re-
search Professor of Government and Public Ad-
ministration, New York University; Chairman, Board of
Directors, Alexander Hamilton Institute.
- ALBERT BUSHNELL HART, Ph. D., LL. D., Professor
of Government in Harvard University.
- JOSEPH FRENCH JOHNSON, D.C.S., LL. D., Dean
and Professor of Political Economy and Finance, New
York University and President, Alexander Hamilton
Institute.
- ASHLEY H. THORNDIKE, A. M., Ph. D., Professor of
English, Columbia University.
- EUGENE LYMAN FISK, M. D., Vice-President and
Medical Director, Life Extension Institute, New York.
- HENRY PRATT FAIRCHILD, Ph. D., Professor of
Social Economy, New York University.
- RUFUS DANIEL SMITH, M. A., Associate Professor
of Public Economy, New York University.
- ANGELO PATRI, Principal Public School 45, The Bronx.
- JOHN J. MAHONEY, Professor of Education, Boston
University, and Director of Extension Courses for
Boston University and the Harvard Graduate School
of Education.

CONTENTS

	Page
Declaration of Independence.....	6
Chapter 1.—We, The People.....	9
Chapter 2.—The Mechanics of Government.....	25
Chapter 3.—Law and Government.....	35
Chapter 4.—The Constitution of the United States.....	47
Chapter 5.—American Citizenship	77
Chapter 6.—Party Government	91
Chapter 7.—Our Vote in Government.....	105
Chapter 8.—Our Representatives in Government.....	121
Chapter 9.—Taxes and Government.....	133
Chapter 10.—National Government	149
Chapter 11.—State Government	171
Chapter 12.—Local Government	185
Chapter 13.—The American City.....	193
Chapter 14.—America—A World Nation.....	209
Questions and Problems Based on Text.....	216
Index	222

ILLUSTRATIONS

The photographs for this book were secured from (1) the Departments and Bureaus of the Federal Government, (2) the Library of Congress, (3) New York Public Library, (4) Underwood and Underwood, and Ewing Galloway, New York, (5) Boards and Departments, New York City and from other sources. The publishers are indebted to David E. Roberts, Division of Prints, Library of Congress, for his valued cooperation.

FEDERAL COOPERATION

The American Viewpoint Society is *authorized* by the Secretary of the U. S. Department of Labor to state that the work it is undertaking in the production of books and educational films for the citizenship classes throughout the United States is done in *cooperation* with and in furtherance of the policies and plans of the Department in its citizenship training work.

IN CONGRESS, JULY 4, 1776

The unanimous Declaration of the thirteen united States of America

WHEN, in the Course of human events, it becomes necessary for one people to dissolve the political bands which have connected them with another, and to assume, among the powers of the earth, the separate and equal station to which the Laws of Nature and of Nature's God entitles them, a decent respect to the opinions of mankind requires that they should declare the causes which impel them to the separation.

We hold these truths to be self-evident, that all men are created equal, that they are endowed by their Creator with certain unalienable Rights, that among these are Life, Liberty and the pursuit of Happiness. That to secure these rights, Governments are instituted among Men, deriving their just powers from the consent of the governed. That whenever any Form of Government becomes destructive of these ends, it is the Right of the People to alter or to abolish it, and to institute new Government, laying its foundation on such principles and organizing its powers in such form, as to them shall seem most likely to effect their Safety and Happiness. Prudence, indeed, will dictate that Governments long established should not be changed for light and transient causes; and accordingly all experience hath shewn; that mankind are more disposed to suffer, while evils are sufferable, than to right themselves by abolishing the forms to which they are accustomed. But when a long train of abuses and usurpations, pursuing invariably the same Object evinces a design to reduce them under absolute Despotism, it is their duty, it is their duty, to throw off such Government, and to provide new Guards for their future security. Such has been the patient sufferance of these Colonies; and such is now the necessity which constrains them to alter their former Systems of Government. The history of the present King of Great Britain is a history of repeated injuries and usurpations, all having in direct object the establishment of an absolute Tyranny over these States. To prove this, let Facts be submitted to a candid world.

He has refused his Assent to Laws, the most wholesome and necessary for the public good.

He has forbidden his Governors to pass Laws of immediate and pressing importance, unless suspended in their operation till his Assent should be obtained; and when so suspended, he has utterly neglected to attend to them.

He has refused to pass other Laws for the accommodation of large districts of people, unless those people would relinquish the right of Representation in the Legislature, a right inestimable to them and formidable to tyrants only.

He has called together legislative bodies at places unusual, uncomfortable, and distant from the depository of their public Records, for the sole purpose of fatiguing them to compliance with his measures.

He has dissolved Representative Houses repeatedly, for opposing with manly firmness his invasions on the rights of the people.

He has refused for a long time, after such dissolutions, to cause others to be elected; whereby the Legislative powers, incapable of Annihilation, have returned to the People at large for their exercise; the State remaining in the meantime, exposed to all the dangers of invasion from without, and convulsions within.

He has endeavored to prevent the population of these States; for that purpose obstructing the Laws for Naturalization of Foreigners; refusing to pass others to encourage their migrations hither, and raising the conditions of new Appropriations of Lands.

He has obstructed the Administration of Justice, by refusing his Assent to Laws for establishing Judiciary Powers.

He has made Judges dependent on his Will alone, for the tenure of their offices, and the amount and payment of their salaries.

He has erected a multitude of New Offices, and sent hither swarms of Officers to harass our people, and eat out their substance.

He has kept among us, in times of peace, Standing Armies without the Consent of our Legislature.

He has affected to render the Military independent of and superior to the Civil power.

He has combined with others to subject us to a jurisdiction foreign to our constitution, and unacknowledged by our laws; giving his Assent to their Acts of pretended Legislation:

For quartering large bodies of armed troops among us:

For protecting them, by a mock Trial, from punishment for any Murders which they should commit on the Inhabitants of these States:

For cutting off our Trade with all parts of the world:

For imposing Taxes on us without our Consent:

For depriving us in many cases, of the benefits of Trial by jury:

For transporting us beyond Seas to be tried for pretended offenses:

For abolishing the free System of English Laws in a neighboring Province, establishing therein an Arbitrary government, and enlarging its Boundaries so as to render it at once an example and fit instrument for introducing the same absolute rule into these Colonies:

For taking away our Charters, abolishing our most valuable Laws, and altering fundamentally the Forms of our Governments:

For suspending our own Legislatures, and declaring themselves invested with power to legislate for us in all cases whatsoever.

He has abdicated Government here, by declaring us out of his Protection and waging War against us.

He has plundered our seas, ravaged our Coasts, burnt our towns, and destroyed the lives of our people.

He is at this time transporting large Armies of foreign Mercenaries to complete the works of death, desolation and tyranny, already begun with circumstances of Cruelty & perfidy scarcely paralleled in the most barbarous ages, and totally unworthy the Head of a civilized nation.

He has constrained our fellow-Citizens taken captive on the high Seas to bear Arms against their Country, to become the executioners of their friends and Brethren, or to fall themselves by their Hands.

He has excited domestic insurrections amongst us, and has endeavored to bring on the inhabitants of our frontiers, the merciless Indian Savages, whose known rule of warfare, is an undistinguished destruction of all ages, sexes and conditions.

In every stage of these Oppressions We have Petitioned for Redress in the most humble terms: Our repeated Petitions have been answered only by repeated injury. A Prince, whose character is thus marked by every act which may define a Tyrant, is unfit to be the ruler of a free people.

Nor have we been wanting in attentions to our British brethren. We have warned them from time to time of attempts by their legislature to extend an unwarrantable jurisdiction over us. We have reminded them of the circumstances of our emigration and settlement here. We have appealed to their native justice and magnanimity, and we have conjured them by the ties of our common kindred to disavow these usurpations, which would inevitably interrupt our connections and correspondence. They too have been deaf to the voice of justice and of consanguinity. We must, therefore, acquiesce in the necessity, which denounces our Separation, and hold them, as we hold the rest of mankind, Enemies in War, in Peace Friends.

WE THEREFORE, the REPRESENTATIVES of the UNITED STATES OF AMERICA, in GENERAL CONGRESS, Assembled, appealing to the Supreme Judge of the world for the rectitude of our intentions, do, in the Name, and by authority of the good People of these Colonies, solemnly PUBLISH and DECLARE, That these United Colonies are, and of Right ought to be FREE and INDEPENDENT STATES; that they are Absolved from all Allegiance to the British Crown, and that all political connection between them and the State of Great Britain is and ought to be totally dissolved; and that as FREE and INDEPENDENT STATES, they have full Power to levy War, conclude Peace, contract Alliances, establish Commerce, and to do all other Acts and Things which INDEPENDENT STATES may of right do. And for the support of this Declaration, with a firm reliance on the protection of Divine Providence, we mutually pledge to each other our Lives, our Fortunes, and our sacred Honor.



©The American Viewpoint Society

Drawing by Hanson Booth

THE SPIRIT OF THE UNITED STATES

When we think of the United States, we think of opportunity, speed, individuality,
vision, earnestness of purpose and resourcefulness

We, The People

Character and National Resources—the Ideal Combination Which
Makes a Great and Outstanding Nation

WE WORKED TOGETHER AND HELPED ONE ANOTHER." According to Rear-Admiral Robert E. Peary, an American, this was the plan that enabled him to reach the North Pole in 1909, after many other heroic explorers had failed. It is the principle to follow in all the work of life, great and small.

Have you ever stopped to think how necessary it is in modern life that all of us work together to help one another? Let us for a few minutes think of the reason for some of the things that in our daily life we take for granted. Early each morning we open the back door, or the dumb-waiter door if we live in a big apartment house in a great city, and take in the bottle of milk that is to be used for our breakfast. It is usually waiting

for us. But suppose that for some reason or other, perhaps a big snow-storm which ties up the railroads, our morning bottle of milk is not on time. What troubles arise! The oatmeal without milk does not taste nearly so good! The baby cannot understand. Then we begin to wonder. "What is the matter?" we ask. And with the question comes the realization of how very dependent we and our family are upon others for our every-day comforts and happiness.

Ordinarily, getting a bottle of milk seems a simple matter. Every morning we look for it and find it in the same spot on the three hundred and sixty-five days of the year. It never enters our heads that a complex business organization is responsible for such a commonplace occurrence; that many people working together furnish us with milk,

and that while some of us have our work to do after a seven o'clock breakfast, others of us have been up and at work much earlier.

Team Work

MAN cannot live and maintain the kind of a society in which we now live without cooperation... Our American Democracy is team work on a great scale. It is a great society composed of individual citizens, organized to be a political **WE** . . . A Democracy is a country owned and managed by all its adult citizens through their government.

A Long Journey

Let us trace the bottle of milk back along its journey. Every morning of the year some milkman must get up at two or three o'clock in order that fresh milk may be delivered for the cereal and the baby. The job of the milkman is a hard, tire-

some task. Part of the price we pay for each quart of milk goes toward his weekly wages.

In the larger cities each driver secures his milk from some central station where it has been *pasteurized* and iced carefully in order that it may be pure and wholesome when it reaches our homes. The central plant has in turn secured its supply of milk from the railroad which runs daily milk trains back along its lines for literally hun-

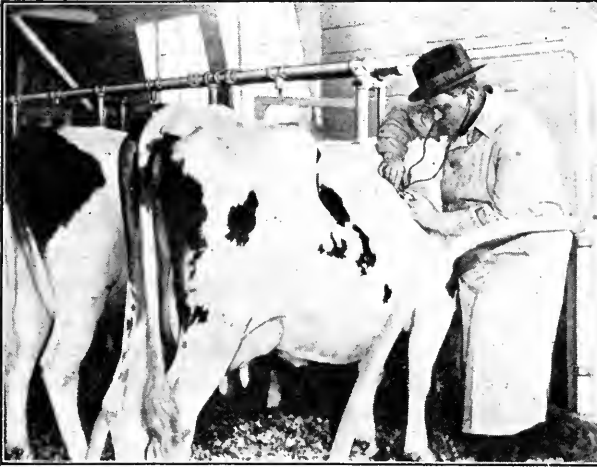

Many people work together so that we will get our bottle of milk every morning. **THE GOVERNMENT EMPLOYS MANY TO TEST THE COWS** to make sure that they give pure milk. There are those who milk the cows and still others who deliver the milk to us.



Great numbers of people work in **THE LARGE STEEL PLANTS** where steel rails are made for the railroads that bring the milk from the country to the city.



THOUSANDS MORE BUILD THE AUTOMOBILES that the farmers use to haul the milk to the railroad stations. 3,000,000 American farmers own automobiles. The automobile industry employs 2,740,000 people.

dreds of miles from the largest cities. To each rural station milk is brought from the surrounding districts by individual farmers. Unless the farmers meet the trains, and the trains are on time, we fail to get our supply promptly. Each individual farmer and his hired man must milk the cows both morning and night without a break in the routine. Out of the price we pay for our milk must go a percentage to each of the workers who have handled it.

Still other individuals are interested in our morning bottle of milk. In order that we may be safe from infected milk, some official of the government has tested the cows for tuberculosis. The government has also required that certain standards of cleanliness be met, that the milk be kept free from adulteration, and that a definite grade of richness of cream and of purity be maintained. Clean milk, pure milk, rich milk, milk on time, means that we and our family keep in good health. There are many individuals who are responsible for these conditions.

The Whole World Helps

This is not all. Many other agencies, indirectly, are called upon. The engineer and the fireman of the train which brings in the milk must be experienced men. The cars necessary to transport such a product as milk have to be especially manufactured in a great car-making plant. The rails on which the milk trains run are produced in a great steel plant, which in turn goes back to the mining centers of coal and iron. The highways to railroad stations were built and

are kept in repair by government officials. The automobiles which the farmers use to transport their milk from the farms to the stations were built by thousands of workers laboring in the factories at Detroit or Cleveland. Even the farmer's tin pail and can and the lowly milk bottle went through many processes in a great tin or glass manufacturing plant. In one way or another the whole world has been drawn into the process of delivering our early morning bottle of milk.

A Great Newspaper

Another interesting example of cooperation is the newspaper. It is the twin, at least in time and importance, to the bottle of milk. The newspaper also meets us at the breakfast table. It is our daily traveling companion. Before we reach the office or workshop we know what has happened throughout the world during the last twenty-four hours. We have read perhaps about a *great fire*, about the happenings at some *important conference* in Washington, of the details of *yesterday's* baseball game, of a severe earthquake in Japan, of a famine in Russia or China, of the President's latest choice for the United States Cabinet, of another *missing link* discovered in the Himalaya Mountains; all told in short, snappy news items that we may read quickly.

What a marvelous organization a newspaper is, from the boy who delivers it in the morning, right back through the printing plant, composing room, to the wireless and cable, and the



Many must work together so that we may get our newspaper every day. **THE STORY OF A GREAT FIRE** must have reporters, editors and printers. Still others, working together, must make the huge rolls of



paper and must build the large printing presses. It took the work of thousands of men and women to give to the world the story of the Conference on Limitation of Armaments, held at Washington. At this Conference, on the last day, February 6, 1922. **PRESIDENT HARDING GAVE AN ADDRESS.** The next day it

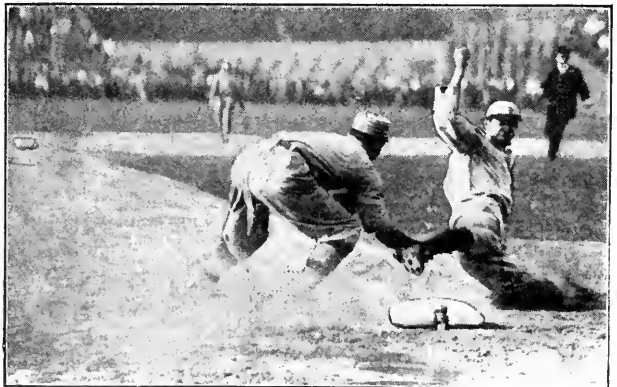

was printed in all the papers. The work of a great many is needed to report a **BASEBALL GAME.**



In the early days of our country people did not work together as we do now. For example, the father of Lincoln built this log cabin IN WHICH THE GREAT LINCOLN WAS BORN, February 12, 1809. Today, we



do not build our homes. **WE HIRE CARPENTERS, PLUMBERS, PAINTERS** and other skilled workers to build them for us. In the U. S. over 3,500,000 are

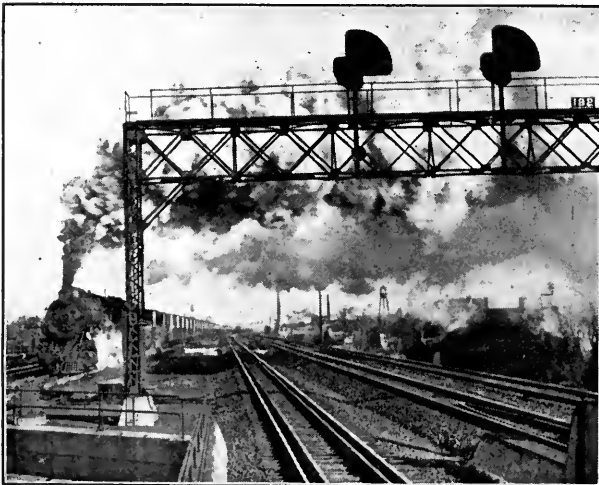

employed in the building trades. **WE ALSO PAY THE RAILROADS** to bring the materials for our homes from distant parts of the country. They haul yearly over two billion tons of freight.

reporters and editors who gather and edit the news.

All these things illustrate the marvelous fact that we are a part of a vast, intricate organization. Modern life is the combined results of the efforts of thousands, even millions, of people, each of whom has contributed his mite of effort. Society is a finely spun, delicate but wonderful organization. To live we must each be dependent on the other, and yet few of us are conscious that we are working to build and support this organization. Our first concern is to get our wages. *How much more interesting and vital our work becomes when we realize its social meaning, that it is our contribution to the support of society!*

Thousands Employed

Take anything which we use, even a silk necktie, and trace it back to its original source, and it will be found that countless men and women have worked to make it. We no longer build our own homes as did the early pioneers in America. We have carpenters and plumbers and painters and architects do the work for us. We in turn, however, are doing something for each of them. We may work in a school as teachers and educate their children. We may be locomotive engineers who carry materials from city to city. We may be lumbermen in the Maine woods or the Canadian forests who cut the trees which furnish lumber for our home or the wood pulp for our newspaper.

But in any case, whatever we do means working together. **Wherever we turn in modern life**

we find the need of cooperation. There is cooperation in the home; business is cooperation on a larger scale. *Man cannot live and maintain the kind of society in which we now live without cooperation.*

The Need of Confidence

Underneath this cooperation is mutual confidence. Unless one stops to think, one little realizes the amount of confidence that one must place in other people. Take money; for example, a paper dollar. What is it worth? As paper—nothing. Why is it worth a dollar? Because behind it stands the good promise and the whole strength and honor of the government. We have confidence that the American Government to its fullest extent is ready to back that paper dollar.

Another example: You buy some groceries and give a check in payment. The storekeeper accepts your check, endorses it, and sends it to a bank. The bank places it to the credit of your store. From there it passes on through a central bank and clearing house until it finally comes back to your own bank where it is charged against your account. You use the whole great banking system of the United States at every step; you place confidence in many and the many place confidence in you. *Mutual confidence—confidence in the integrity, in the proficiency, in the honesty, in the good intentions of others—is the keystone around which modern society is built.*

You buy an automobile of a well-recognized make. You do not test every part of that machine yourself. You are confi-



In order to work together we must have faith in each other. When **YOUR GROCER ACCEPTS YOUR CHECK** in payment for the tea, sugar and flour that you buy, he shows confidence in you. He



believes that your check is good, endorses it, and sends it to his bank, where it is placed to his credit. From there it passes to a Central Bank and Clearing House until **IT FINALLY COMES BACK TO YOUR BANK**, and is charged against your account. In

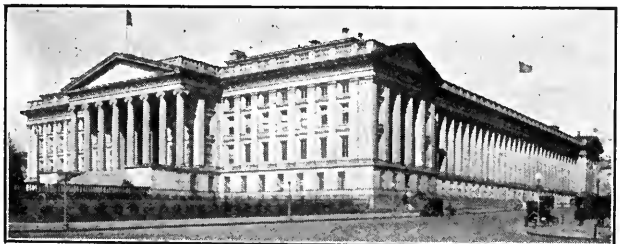

THE UNITED STATES TREASURY a record is kept of all money—gold, silver, and bills—that is issued by the National Government.



Because we have faith in each other this is a safe country to live in. There are people, however, who seek to destroy confidence by breaking the laws. He who breaks a law commits a crime and **MUST PAY A PENALTY FOR HIS CRIME.** Because there are



such people we need the police. The police have many other duties. One of the important duties of the police is to **REGULATE STREET TRAFFIC.**

dent that a machine of that make has been thoroughly tested *before* it comes into your hands. Confidence is the basis of modern life. *The man or woman who attempts to destroy this confidence by thoughtless, selfish or criminal acts, is an enemy of the community.*

Basis of Government

Cooperation and confidence, so necessary in modern life, also form the basis of *Government.* Government is organized for the purpose of looking after common interests, interests that can be best handled by the cooperation of us all. A *state* is similar to any other organization created for a definite purpose. It is all of us organized into a *political* society for the purpose of serving the common good, and without this organization we could not receive this service. All of us, each active as a separate individual, would be too weak; all acting together are mighty.

The purpose and need of government is illustrated many times a day. "That's the best *cop* in town," said George, as the policeman at the corner of Fourth Avenue and Twentieth Street, New York, with uplifted hand stopped the traffic. He motioned a young woman with a little girl to cross the street, took gently the hand of the child and helped her across, started the traffic promptly and in a minute had everything running safely again. "How is he better than the policeman at the corner of Lafayette and Canal Streets?" I asked. "He handles the traffic just as well, and besides he's kind to the women and especi-

ally looks after children," said George, who has boys of his own.

Backed by the State

We seldom think of a policeman as the special protector of women and children. Usually we think of him as the guardian of life and property against criminals. But he is needed to keep order among the well-meaning citizens as well as to protect us from the acts of criminals, or to force criminals to answer for their acts. Nine out of ten of the automobile drivers mean well and are reasonably careful. They do not wish to hurt anyone. They do not wish to be needlessly selfish in disobeying traffic rules, but no two automobile drivers think exactly alike. No two of them see the traffic from exactly the same point of view. Therefore, someone with authority is necessary to direct the traffic. With an able officer in charge who has the power of the whole State back of him, not only are our streets made safe, but the traffic moves along more rapidly and easily.

Need of Umpires and Rules

When we think of a traffic policeman as a director who smooths our way, we have hit upon a new conception of government. What is true of street traffic is equally true of many things in our daily life. The great majority of us have good intentions. We are willing to do our share for the good of all, but since we are individuals, with separate minds, each thinking in his own way, we form different plans and do things in different ways. Unless there is some impartial umpire with real



The police are hired by the people organized as government. Some cities also have WOMEN POLICE



a part of whose work is to look after the children. States employ CONSTABULARY OR STATE POLICE, to keep order in the country and small towns, and to hold in check those who by their acts are

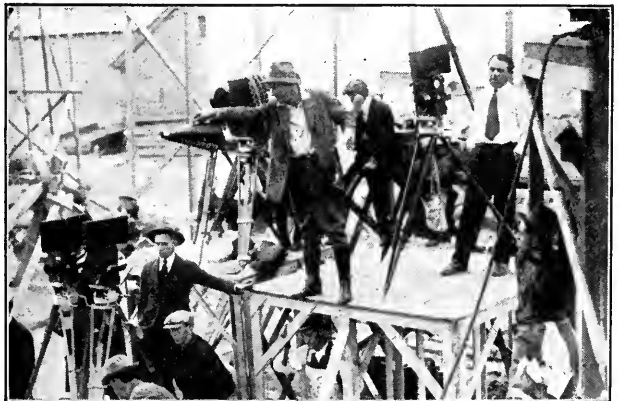

enemies of the people. Police are needed just as directors are needed to make moving pictures. WITHOUT A DIRECTOR no moving picture could be made.



Some who are enemies of the people are not criminal at heart but are careless or thoughtless. The man who tosses away a lighted cigarette does not mean to start a fire, yet **MANY FIRES ARE CAUSED THIS WAY.** It is because so many are careless that our yearly loss through fire is over \$250,000,000. The



thoughtless person who spits on the sidewalk would not do so if he gave a thought to the thousands of people who are **SICK WITH TUBERCULOSIS.** This disease is often spread by spitting. For people who



are thoughtless, as well as for those who are criminal, we must have **LAWS, POLICE AND THE COURTS.**

authority who enforces the rules that we have mutually agreed upon, we should live and work continually at cross purposes.

How could the actors, the electricians and camera men work in harmony to produce a moving picture if they did not follow the instructions of the director? Without him there would be confusion. In like manner, with so many people doing so many things in so many different ways, without laws and their rigid enforcement, there would be endless confusion in any city or any nation. This confusion would become very serious unless there were uniform rules or laws that apply to all the people so that each one may know in advance just what he must not and must do, so far as his acts affect the comfort of his neighbors.

Bad Neighbors, Poor Citizens

In every community there are people who object to rules. Some of these are merely thoughtless or careless, some ignorant, some selfish, and some actually criminal. The thoughtless and the selfish would like to act as they please regardless of the comfort and welfare of others, provided the law would permit. They who carelessly throw away their glowing cigarettes, or thoughtlessly drop their orange or banana peelings on the sidewalk, have been responsible for many costly fires and serious accidents.

Spitting on the sidewalk is also an act of the thoughtless, selfish, or ignorant citizen which may result in sickness and death to others. It spreads tuberculosis and other dread diseases.

Such a person is simply a bad neighbor and poor citizen, but not a criminal *at heart*. Others, as for example, thieves, have no respect for law and are willing to break it in order to gain their evil desires, hoping that they will not be caught. *For protection from the acts of such people, not only criminals, but also the thoughtless, selfish and ignorant, we must have laws, the police and the courts.*

More Examples

Let us have a few more examples of the need of government. When, as a result of the Spanish-American War, the United States, in 1898, came into control of the Philippine Islands, smallpox was a very common disease that carried off thousands of natives every year. We had already learned the value of *vaccination* as a safeguard against this disease. In their ignorance the natives objected to being vaccinated, but our Government insisted, as it does with us. In one year, more than a million people in these islands were vaccinated, and as a result smallpox was banished from the Philippines within the short space of two or three years. Only by good laws and a strong government were the people of these Islands saved from paying the penalty of their own ignorance.

"*SWAT THE FLY*" is, in many of our towns and cities a popular and a wise slogan, for the fly is a very common carrier of many kinds of contagious diseases, especially cholera and typhoid fever. These, along with other epidemics, are spread by infected food and drink. Modern



Then there are enemies of the people who are ignorant. It is because some dealers who sell cakes, candy or fruit are ignorant of the danger of flies that the city government sends men to teach them the need of **PROTECTING FOODSTUFFS FROM THE FLIES.**

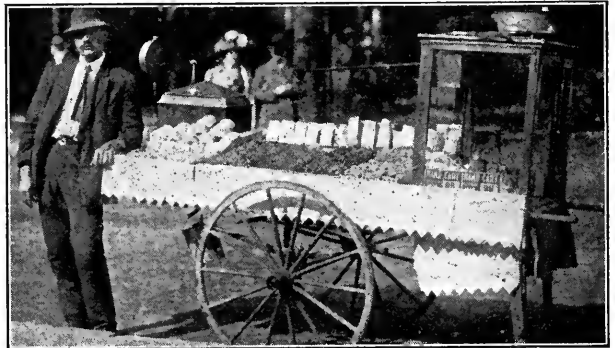

One should not buy **CANDY THAT IS SOLD FROM CARTS** unless it is covered with glass. The people,



through their government, also hire experts to **TEST THE FOOD SOLD IN TINS AND JARS.** They who knowingly sell impure foods are criminals.



It has been shown that the police are political or public servants. There are many other kinds of public servants. **THE CITY EMPLOYS MANY DOCTORS AND NURSES** to protect our health and to see that the city's health laws are obeyed by the people.



SCHOOL TEACHERS ALSO ARE PUBLIC SERVANTS. They do work of the greatest good. Not only do they teach reading, writing and arithmetic



but they also give to the girls lessons **IN HOUSE-KEEPING** and teach the boys useful trades.

medical knowledge is showing to us how other insects, such as the mosquito, carry other diseases. Several of the doctors in the *Public Health Service of the United States Government* have given their lives in fever-ridden districts of Latin America in order to prove how yellow fever is carried from insects to human beings.

As a result of this medical knowledge regarding the spread of certain diseases by flies and other insects, rules for covering fruit, candy and food-stuffs at street corner stands and on market wagons and carts are made and enforced. For the same reason special rules must be made by the Government for the inspection of meat markets and market supplies of various kinds.

Healthful, nourishing foods may be rendered harmful by being brought into contact with that which is infected. The only way to prevent such infection is to pass rigid laws and strictly to enforce them. Such laws as those contained in the *Federal Pure Food and Drug Act* are necessary for public health. This Act is of great benefit and help to everyone.

Government An Agent

Government, as these few illustrations show, is our agent. It acts in the interest of the common good. It protects us. It also gives to each of us a better chance to make the most of his talents; to become the best and greatest man that natural gifts will allow. It is *organized good* opposed to *individual selfishness*. It is all of us organized for the purpose

of providing for our mutual welfare. We, as working people, are carpenters, miners, painters, stenographers, plasterers, doctors, lawyers, printers, long-shoremen, engineers, firemen or business men. At the same time we are citizens and there are some things that affect all of us, no matter what our occupations.

Organized Into Groups

In order to take care of these common needs we have organized ourselves into the *United States of America*, or *State of New York*, or *City of Cleveland* or *New Orleans* for the purpose of placing our common needs in the hands of other workers—public servants—teachers, policemen, street cleaners, nurses, legislators, judges and mayors. We, the People, pay these workers of ours to look after our needs.

Our relation to governmental service is very aptly illustrated by the answer a father made to his little daughter: "Father," said the child, "I'm awfully afraid of that policeman on the corner!" "You should not be, daughter," was the reply, "I am helping to pay his salary to have him take care of you."

This is a good point of view to have toward government. On the other hand, each individual, through government, is enabled to enjoy a liberty of action which would not be possible under other conditions. Without government either selfish or criminal individuals might well interfere with our freedom of action and our right to work and live as seems best to us. *The government servants free us from the need of spending our time in*



LEGISLATORS ALSO ARE PUBLIC SERVANTS. They are chosen by the people at election time to make new laws and to provide the means of enforcing the old laws. The important work that public



servants do for us is clearly shown at the time of an accident. Then **POLICE PATROLS AND CITY AMBULANCES** rush to the place where the accident happened to give first aid to the injured person or



persons. **STREET CLEANERS ALSO ARE PUBLIC SERVANTS.** Clean streets and alleys make the city a much healthier place in which to live.



The people, organized as government, do many things that we as individuals could not do. This shows the need of government. The authority that our government has for doing these things comes from the people. In July, 1776, the DECLARATION OF INDEPENDENCE was signed in the name and by



the authority of the people. THE CONSTITUTION OF THE UNITED STATES begins with the words, "WE, THE PEOPLE OF THE UNITED STATES."



In 1620, the Pilgrim Fathers signed the MAYFLOWER COMPACT. It also was an agreement of the people.

looking after many things, and thus permit us to give more time to our individual duties.

Democratic Documents

The Constitution of the United States in its *Preamble* gives one of the best statements of the purposes of government to be found anywhere. It says:

"We, the People of the United States, in order to form a more perfect Union, establish justice, insure domestic tranquillity, provide for the common defense, promote the general welfare, and secure the blessings of liberty to ourselves and our posterity, do ordain and establish this Constitution for the United States of America."

The Mayflower Compact, that historic document written by the Pilgrims who landed on the Massachusetts coast in 1620, is also remarkable for its clear statement of the purpose of government. In part it reads:

"We whose names are underwritten, having undertaken, for the glory of God, a voyage to plant the first colony in the northern part of Virginia, do solemnly combine ourselves together into a civil body politic for our better ordering; and to frame such just and equal laws, from time to time as shall be thought most convenient for the general good of the colony, unto which we promise all due obedience."

Here, also, we have the idea of the people organizing themselves into a political body in order to form rules for the general good of all. And here, too, we note the need of obedience to these common laws.

Spirit of Democracy

These documents bear the spirit of democracy. Both contain the essential idea of democracy. The Constitution of the United States begins with "*We, the People.*" The Mayflower Compact begins in a similar manner: "*We do solemnly combine ourselves.*" The essence of democratic government is to be found in these words: *We get together; we combine; we look after our common interests; "We, the People" must work together in order to provide for the common good. A democratic government is mutual cooperation and organization of neighbors one with the other for the purpose of meeting the general needs.*

Read every great democratic document of history, from the *Magna Carta* and *Bill of Rights* of England to the new Constitutions of the Republics of China and Czecho-Slovakia, and you will find them alike in their emphasis upon common needs. A democracy is a society cooperating for the good of all. It is a government owned and managed by its citizens. *Our American Democracy is team work on a great scale.* It is a great society composed of individual citizens who are organized into a political WE. The American Democracy has been organized in order that the opinions and policies of the citizens may find free expression.

Size and Production

What picture comes in our minds when we say "*We, the People?*" All too often we see a map, a map of a great



In 1215, the nobles of Great Britain forced the King to sign THE MAGNA CARTA. This great document stated the rights of the individual against wrongdoing



on the part of the government. In 1918, the PRESIDENT OF THE REPUBLIC OF CZECHO-SLOVAKIA signed, in Independence Hall, Philadelphia, the Declaration of Independence of his people. This Declaration is patterned after the Declaration of Independence of the United States.



A strong democratic government can come only from a people of character and intelligence. The character of the people of this nation was shown in the great World War. When we **BUILT SHIPS AT THE RATE OF ONE A DAY** we, as a people, showed



speed, resourcefulness and earnestness of purpose. The spirit of the nation was shown when millions of our young men **WILLINGLY LEFT THEIR HOMES**



FOR THE TRAINING CAMPS and Europe, in answer to their **PRESIDENT'S CALL TO ARMS.**

country with a long seacoast, with many wonderful harbors, with vast forests, and glorious scenery, with inexhaustible mines and great cities. In America we think too often in terms of size, of the vast numbers of bales of cotton, of the millions of bushels of wheat, or of the tremendous amount of coal which we produce.

Character More Important

The real growth and strength of our nation or any other nation depends upon something more than material things like resources and production. As James Russell Lowell, American author and publicist, wisely said: "*Material success is good, but only as the necessary preliminary to better things.*" "*We the People*" and our *character* are even more important than mines and fertile fields.

When we think of France, we think of the spirit of the French as expressed in those immortal words at the Battle of Verdun: "*They shall not pass!*" When we think of the Irish, we think of a race rich in humor, in imagination, in courage. Scotland immediately brings to our mind the integrity, the steadfastness and the strength of will of the Scotch. At the mention of England, we think of tenacity of purpose as shown by Nelson at Trafalgar. When the Italians come to our mind, we think of their industry and their love for art and music. When we think of China, we think of its civilization which has existed for thousands of years; we think of Chinese trustworthiness, and their tremendous capacity for work, of their great sense of

justice and honor. *When we think of the United States, we think of opportunity, speed, individuality, vision, earnestness of purpose and resourcefulness.*

The World War

When our love of freedom and justice summoned us to enter the Great War, the American people sprang to their grim tasks. The workers of the nation cheerfully answered the call to speed up production. Ships were built at the rate of one a day. Business and professional men left their desks and laboratories to place their trained minds at their country's service. Our young men, by the millions, ungrudgingly flocked to the camps and from there to the battlefields and performed deeds of valor, bringing to the nation undying glory. History gives no other example equaling the speed and energy and resourcefulness of America's response to its President's call to arms. *Every great nation is first built upon the character of its people.* As Viscount Bryce, the author of *The American Commonwealth*, said: "The History of the nation is the history of the men who compose the nation, and not of their dwelling place."

But when we have a nation which is rich in its resources and has also a people of noble character, then we have the ideal combination which makes a nation fit to guide the destinies of the world.

Enlightened Democracy

We must not forget that America is the first great successful Democracy, and that for scores of years after its foundation the rest of the world prophesied its failure. But it did not fail. American Democracy spread. The Great World War was fought, in fact, for the maintenance of the American idea of Democracy.

And now as we look forward into the future we see the doom of despotism, and we entrust the happiness and safety of the peoples of the world to *enlightened Democracy*. We have because of this great thought become the leader and *inspiration of the nations*, and we must keep our thought and purpose sound and pure.

It is a combination of these two essentials—unlimited resources and people of character—that makes this great democracy of ours—THE UNITED STATES OF AMERICA!

"That we here highly resolve that . . . this nation, under God, shall have a new birth of freedom—and that government of the people, by the people, for the people, shall not perish from the earth."—*Abraham Lincoln*.

✦ ✦ ✦

"It is vain to hope for the success of a free Government without the means of insuring the intelligence of those who are its source of power."—*Rutherford B. Hayes*.

✦ ✦ ✦

"The will of the people is the end of all legitimate government."—*John Quincy Adams*.

✦ ✦ ✦

"We admit of no government by divine right . . . that all are upon an equality, and that the only legitimate right to govern is an express grant of power from the governed."—*William Henry Harrison*.

✦ ✦ ✦

"Our Democracy means that we have no privileged class, no class that is exempt from the duties or deprived of the privileges that are implied in the words, 'American Citizenship.'"—*Theodore Roosevelt*.

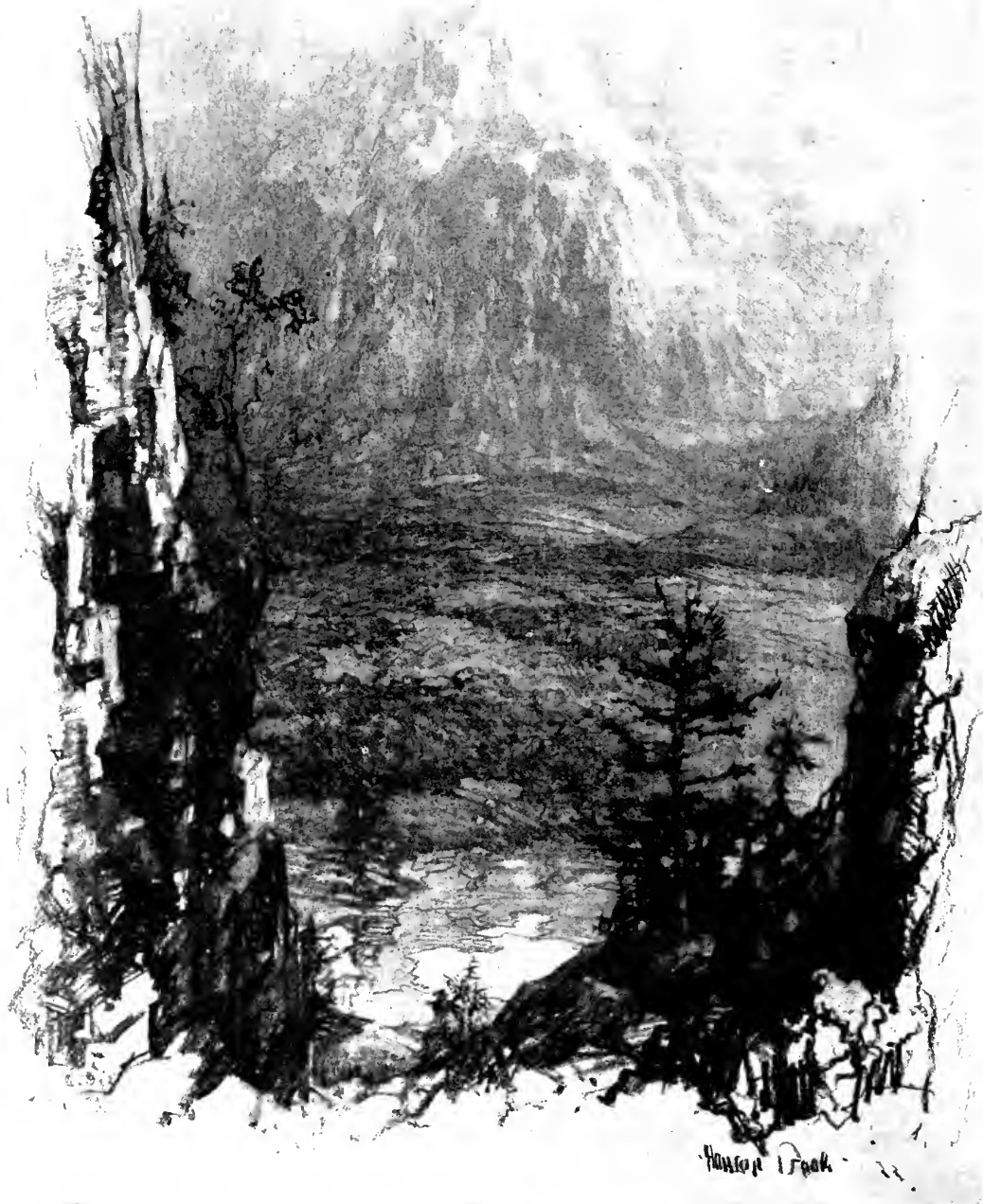

©The American Viewpoint Society

Drawing by Hanson Booth

OUR NATIONAL WEALTH

The development of our natural resources, such as water, minerals and forests, is a matter that should be looked after by the Federal Government.

The Mechanics of Government

We, The People, Are the Members of a Great Corporation, and the Men and Women Whom We Elect Are Our Business Managers

THE UNITED STATES IS ALL OF US—*WE, THE PEOPLE*—ORGANIZED FOR THE PURPOSE OF GOVERNMENT. How are we organized for this purpose in the United States?

There are different ways of carrying on the business of a nation just as there are many ways of organizing a business. One

business may be run by a single individual. The owner is the *boss*. His decisions are final. Another business may be organized into a partnership with two or more individuals sharing the task of looking after its activities.

A corporation form of organization may be used with stockholders, a board of directors, a president, vice president, secretary, and a treasurer. A nation also may be run by one person who considers it his own private property and uses it for his own selfish purposes. But, on the other hand, a nation may be run on the corporation plan with a few people or many as the members, and a few or many officers to run the business.

The corporation plan is the one used by most governments today. *We, the people, are the members and stockholders of the corporation. The people whom we elect to run the business of government are our own business managers.*

When we read the newspapers and magazines we are often confused by some of the words that are used to describe governments. We become familiar with such words as *monarchy, oligarchy* and *democracy*, but we seldom take the trouble to find out what they really mean. How many of us can tell what a monarchy is? There are the mon-

archies of Great Britain, Japan and Spain. Are they alike because each has a monarch who is supposed to lead? Certainly not; they are very different. Are the Republics of France, Switzerland, Mexico and the United States governed exactly alike? They differ greatly both in spirit and form. Is Great Britain with its king any less democratic than France with its president? No, both countries are controlled by the

Three Duties

THE three duties of Government are:

- 1 To make the law;
- 2 To administer the law;
- 3 To interpret and enforce the law.

All three working together promote the best interests of the people... It is our duty to do all in our power, as individuals, towards making these three functions of Government work properly.

people. Both are responsive to public opinion. In each, the people have organized themselves for the purpose of government.

Snap Judgments

The above questions show how very careful one must be not to make snap judgments about the government of a country. There is a vast difference between governments. Sometimes a name means nothing. Nations are often

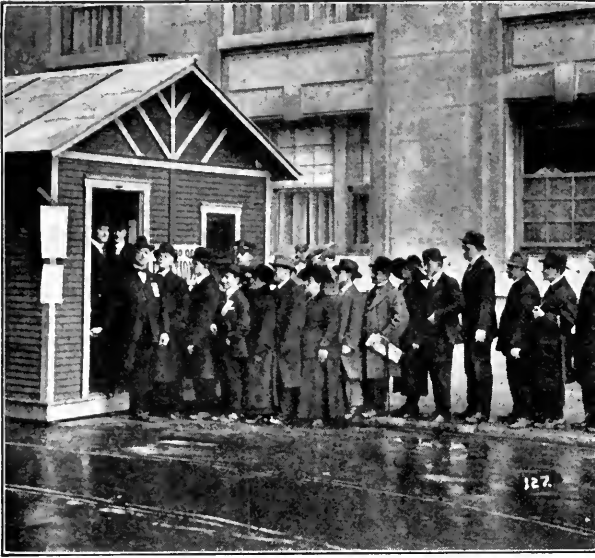

There are three reasons for calling the United States a true democracy. First, almost ALL THE MEN AND WOMEN IN THIS COUNTRY CAN VOTE.



Second, the representatives must TELL THE PEOPLE WHAT THEY HAVE DONE while in office. Third, the United States Constitution, or the State Constitutions, which contain the fundamental laws, can be changed by the people's representatives, or,



in the latter case, sometimes by the votes of the people themselves. In most of the States of the Union one must be a citizen before he can vote. Therefore, all who live in this country, and who are of age, SHOULD BECOME CITIZENS.

called *radical*, *liberal*, or *conservative*; yet we can understand next to nothing of the meaning of these terms until they are explained by the person using them. There are three very important tests which determine the democracy of any given country.

First Test for Democracy

The *first* test for democracy is to find out what percentage of the people of a country can vote and thus take a legal part in the government. The right to vote is all-important. Only those who have it can either make laws directly or elect representatives. To be without the right to vote is to be without the right to determine the policies of the government. A country, therefore, could hardly be called democratic where voting is limited to a small percentage of the people. Such a country leaves too much power in the hands of a few. *Therefore, the first essential of a true democracy is that practically all the men and women over the age of twenty-one shall have the right to vote.*

Second Test for Democracy

The *second* test for democracy is to find out if the elected representatives of the people are required at certain stated times to tell the people what they have done while in office. The officials of a democracy are required to act *for* the people. They are responsible *to* public opinion. They may not do as they please. They should not hold office on account of their family name, nor because of their wealth. They should be chosen because of their honesty, ability and willingness to serve.

Third Test for Democracy

The *third* test for democracy, and possibly the most important, is to find out who has the right to change the fundamental law of the land, which is to be found in the Constitution. Is this great right given to a czar, or a kaiser, or an emperor? If so, there is no democracy in the country. In a democracy, the power to change all laws, from the highest to the lowest, must rest in the hands of the people or in representatives who are directly elected by the people. To find out how democratic a country is, we should always apply this last test and the other two just mentioned. *A government, no matter by what name it is known, that cannot stand these three tests is not a democracy.*

Government is Practical

The word *democracy* is a combination of two Greek words which, written in English, look like this: PEOPLE to RULE. The tests just described show how important the people are, yet they do not show how the people are *to rule*.

The people can rule because they have organized themselves into groups each of which has a very definite work to do. These groups are: first, local groups, such as the *county*, the *town* or the *city*; second, the *state*; third, the *nation*. All of these parts must work together with the greatest efficiency, like the parts of an automobile, if the best results are to be obtained.

Local Government

There are certain things that each part of a government can do best if limited to a small area

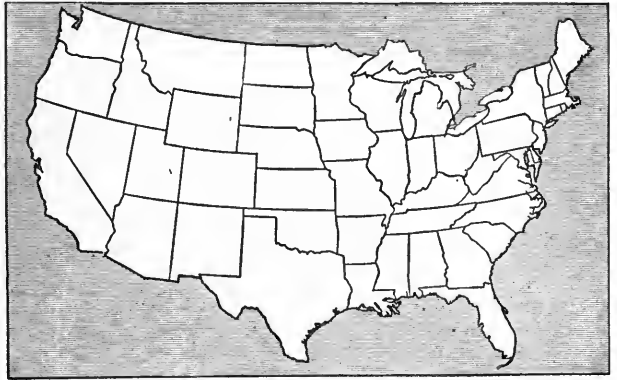

Continental United States has an area of 2,974,000 square miles. Its population is over 105,000,000. In a country so vast, it would be a difficult matter for a democracy to succeed unless the country was organized for the purpose of government. So the land was organized into FORTY-EIGHT STATES. Each



state was organized, as Michigan, into COUNTIES. The counties are divided into townships. Villages,

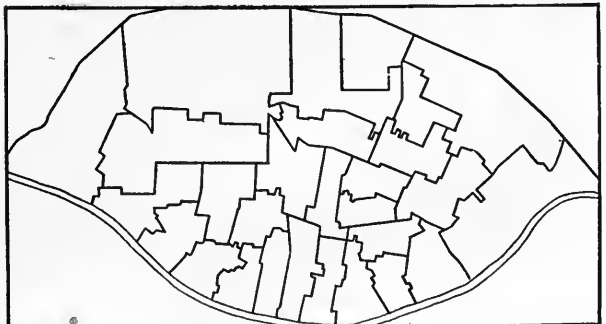

towns and cities belong to another group. Even the CITIES ARE DIVIDED INTO WARDS. The ward system of the city of St. Louis is here shown.



The cities, towns, villages, counties and townships look after their own affairs. This is the business of local government. Detroit, for instance, must REPAIR ITS STREETS, OR FIX ITS WATER MAINS



when they burst. PITTSBURGH, alone, can say how high its buildings should be. These things inter-



est only the people living in certain localities. But no city or township may alone do what it likes with THE PUBLIC SCHOOL SYSTEM. For education is a matter that interests the people of a whole state.

and to a small number of people. The care of the streets in Detroit is certainly not of interest to the people in Denver. Whether Pittsburgh should limit the size of its skyscrapers, is not for the people of St. Paul to decide. These questions concern only those people living in the same localities. They must be settled by county, town, or city governments—*local government*.

In small areas like a village, or town, or even a county, or, as in one of the small *cantons* in Switzerland, the people may come together in a town meeting and themselves vote taxes and appropriations or make laws. This is sometimes called a *pure democracy* in distinction to a *representative democracy*.

The State Government

Other needs, however, must be looked after by a larger unit of government. *Education*, for example, is a matter which concerns too many people to be handled by single independent towns. *Family matters—the regulation of marriage and divorce and the care of children*—should be dealt with by an even larger group than that which represents a large city. *The right of property*—that is, the right to gain it, to use it and to dispose of it—is too great a question for small groups to decide. Great masses of people are involved. Nearly all business is done through agreements or contracts and it is essential that these be properly made and judged. It would lead to confusion and ruin if each small local group had, for example, different laws regarding contracts. The same rule holds true regarding crime, its punish-

ment or prevention and the policy of dealing with criminals. The law must be made uniform by the consent of many villages, counties, towns and cities, acting together in what is called a *state*.

This is the second largest group or unit of our government. New York, Illinois and California are group names familiar to most of us. The state, through its power to make and enforce laws, touches more closely the lives of men, women and children. *It is primarily state laws that govern the personal affairs that affect closely our liberty and prosperity.*

National Government

Just as there are some affairs best looked after by each state, so there are others best turned over to the judgment of the people of all the states acting together in what is known as the *United States*. This idea of common action by several states, called a *federation*, is primarily an American idea when carried out into a real Union such as ours.

In our country most of our business is transacted by the use of money. It would be most inconvenient for us to do business in New York in terms of *dollars*; in California with some other kind of money, such as English *pounds sterling*; in North Carolina with French *francs*; and in Illinois with Italian *lire*. It is very desirable that the same money standard be used throughout the United States, and that this money be uniform in weight, size, shape and value. This ideal would never be reached if each state acted independently in the coining of money.

But money is not the only



The same is true regarding the prevention or punishment of crime. Therefore, **THE COURTS ARE UNDER STATE CONTROL.** But there are some



things that even a state government cannot do. It cannot coin money. This is the work of the National Government. **THE BUREAU OF ENGRAVING AND PRINTING, Washington,** makes our paper money.



Each printed sheet of banknotes **MUST BE CAREFULLY EXAMINED** by experts. Our gold, silver and copper coins are made in the U. S. mints. The largest government mint is in Philadelphia, Pa. Other mints are in New Orleans, San Francisco, Denver and Carson City.

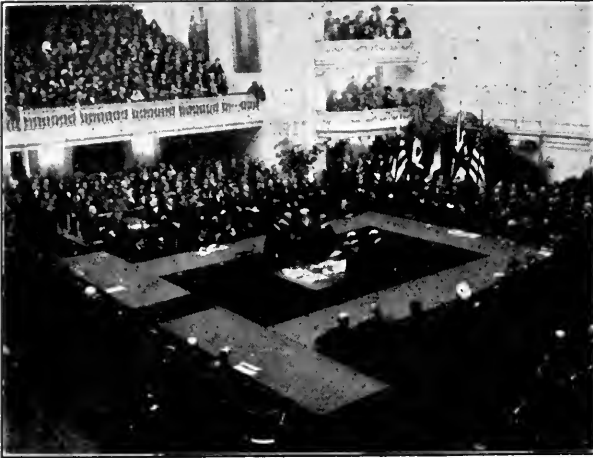

Only the National Government can deal with other nations. The President, who is its head, alone could call, for instance, the CONFERENCE ON LIMITATION OF ARMAMENTS at which all nations invited



sent some of their most able men. Our Secretary of State, CHARLES E. HUGHES, was chairman of this great Conference. He is the second man from the left in the picture. Nations have diplomats in Washington



all the time. THE REPRESENTATIVES or DIPLOMATS to this country from that great nation, Italy, are here shown. American interests abroad are looked after by our Ambassadors and Consuls.

matter that should be handled by the nation; there are others. The *post-office* touches our lives very closely and must be directly managed by the National Government. The development of our *natural resources*, such as water, minerals and forests, is another matter that should be looked after by the nation.

Relations with Other Nations

Only the *nation itself* is qualified to deal with the other nations of the world. Every country in modern times has dealings with other countries. These relations are very important, inasmuch as they involve the question of peace or war. The great *Conference on the Limitation of Armaments*, held in Washington in the winter of 1921-22, included the delegates from nine countries, and included in its range the whole Pacific Ocean and the countries which it borders. Questions raised at such a conference are of the highest importance. A war once started in that part of the world would affect over a billion people. It would directly affect the lives of Americans, Canadians, Australians, New Zealanders, Filipinos, Japanese, Koreans, Chinese, Englishmen, Frenchmen, Dutchmen, Russians, Mexicans, and all South and Central Americans, to say nothing of its enormous consequences to the rest of the world.

Naturally such important problems cannot be managed by the separate states of the American Union. All nations should appoint experienced and wise ambassadors, ministers and counselors to deal with such questions.

Thus confusion is avoided when the National Government transacts all international business instead of leaving it to the separate states. It is only by uniting into the United States of America that we are strong enough to impress other nations.

Other Divisions of Government

So far it has been pointed out that the people are strong because they have divided themselves into certain workable groups called villages, towns, counties, cities, states, and the nation; that each group has certain duties to perform; that if it were not for the harmonious working together of all of these groups the people could not rule.

We may now consider another wise arrangement that we, the people of the United States, have made so that our government would work smoothly. Just as we have divided ourselves into great groups, so we have divided the people that represent us into three main divisions, each having a special kind of work to do. These three divisions are the *legislative*, the *executive* and the *judicial*.

The Legislative Division

From the very nature of the case the first task of our government is to lay down the rules by which all of us must be guided in our actions. These rules must be made to suit the wishes of the majority, and to promote the welfare of the people in the community. As we put it: *The Majority Rules*. In order that these rules may be formed in an orderly manner, we elect certain men to study our problems and to put the needed rules into



Government, whether it be local, state, or national, is made up of three main divisions, each having a special work to do. These divisions are the legislative, the executive and the judicial. The legislative division makes the law. In a city, a body usually known as THE CITY COUNCIL, makes the law.

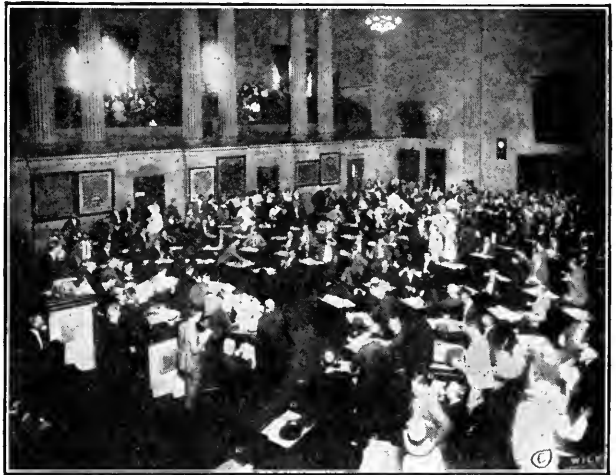

In a state, THE STATE LEGISLATURE, made up of legislators, makes the law. The legislative division of

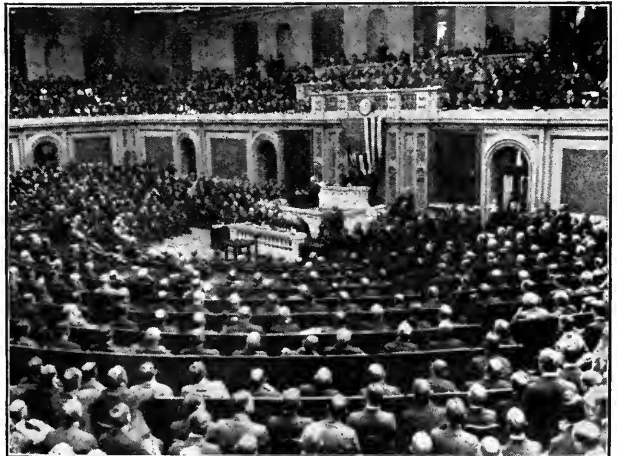

the National Government is CONGRESS, which is composed of two bodies—the Senate and House of Representatives. The people elect members of all these three bodies.



After laws are made they must be administered. The administration of law belongs to the executive division. A **MAYOR** is the executive for a city. He



administers the laws for the city. A **GOVERNOR** is the executive for a state and administers the laws for



his state. **THE PRESIDENT** is the chief executive. He administers the national laws. The third division is called the judiciary. Its members are called judges. Their duty is to interpret and enforce the law.

laws. When such lawmakers represent the people of a city, they are generally called *city councils*. Bodies of this sort make rules that are known as *local ordinances*.

When the elected lawmakers, representing the various sections of the state, come together in a body, they are known individually as *legislators* and together as the *state legislature*. For convenience and thoroughness in handling their work, such state legislatures are divided into two groups, usually known as the *Senate* and the *House of Representatives* or the *Assembly*.

When the elected lawmakers representing the various states come together as a group, they are known individually as *United States congressmen*, and collectively as *Congress*. For convenience and thoroughness in handling its work, Congress is divided into two parts which are called by the same names as the two divisions of the State legislature, namely: the *Senate* and the *House of Representatives*.

All of these bodies come together for the same purpose—to make laws. Each has its own field within which it must work. The local group makes only *local laws*; the state group makes only *state laws*; the national group makes laws which concern the whole country.

The Executive Division

After laws are made they must be enforced. There must be some definite group chosen to carry out the will of the majority. There must be some group that will carry out the laws and see that the people do their legal duties. For this purpose the

people have selected a group of officers that is known as the *Executive*.

The *Mayor* is the head of the town and city law-enforcing body. Under the mayor are several chief city officers who in turn have under them men and women who administer the laws.

In the states the executive consists of the *Governor* and a corps of chief officers, many of whom are elected by the people, but some of whom are appointed by the governor with the approval of the senate.

For the nation the *President* is the chief executive. With him work the Vice President and a small group of men known as the *Cabinet* and selected by the President. These officers constitute the group which administers the law.

The Judicial Division

Beside the law-making group, and the law-administrative group, there must be a *law-judging group*. The meaning of the law has to be made clear. Questions continually arise. Some people claim that a given law means one thing, while other people say that to them it means just the opposite. Decisions must be reached and people must be compelled to abide by the laws, or to suffer the legal penalties if they disobey them. That part of the government which decides what the laws mean and which inflicts penalties for violation of the laws, is called the *judiciary*. The sep-

arate persons in the judiciary are known as *judges*.

A *justice of the peace* is a judge who acts in a village or township. A *magistrate* is a judge in a city. Judges of the State Supreme Court decide upon the meaning of the laws pertaining to the state. They are known as *chief justices* and *associate judges*. The nation has also its law-judging body—the *federal courts*, with the *United States Supreme Court* at its head. They interpret the law as it applies to the United States, more especially as it touches the *Constitution*.

The preceding paragraph completes a general description of the three great functions of government: (1) *to make the law*; (2) *to administer the law*; (3) *to interpret and enforce the law*. All three working together promote the best interests of the people.

Government is intended to improve living conditions. It compels us to uphold definite standards. It produces order and security. Through it we enjoy liberty, for it makes it possible for us to carry on our chosen work without interference from the thoughtless and the criminal. Government represents the system that we ourselves have built. Without it, as a people, we should be weak. *It is our duty to do all in our power, as individuals, toward making these three divisions of government—the legislative, the executive and the judicial—always work properly.*

“America is another word for opportunity.”—*Emerson*.

* * *

“The government is expressly charged with the duty of providing for the general welfare.”—*Abraham Lincoln*.

* * *

“. . . Of all the various modes and forms of government, that is best which is capable of producing the greatest degree of happiness and safety, and that is most effectually secured against the danger of maladministration. . . . When a government shall be found inadequate or contrary to these purposes, a majority of the community hath an indubitable, unalienable and indefeasible right to reform, alter or abolish it, in such manner as shall be judged most conducive to the public weal.”—*Section III, A Bill of Rights, The Convention of Virginia, 1776*.



©The American Viewpoint Society

Drawing by Hanson Booth

THE RULE OF LIFE IS ORDER

The game of life, especially in a great city, without rules or umpires or penalties, would simply mean the trampling of the weak by the strong

Law and Government

Law in a Democracy Grows out of Public Opinion, out of the Views of a Majority of the People

KILL THE UMPIRE; he's rotten!" yell the fans as the local star slides home and is called out. Rules and umpires, what troublesome things they are, yet how necessary wherever people play or work together! "Play ball," snaps the umpire as the argument among the players becomes hot over a decision. "Get off the field," he orders an offending player who uses abusive and profane language.

Laws, rules, umpires, penalties are necessary in every walk of life. Despite our dislike of being hemmed in by restrictions, we may not act as we please. Life is too complex. We live among too many neighbors. The game of life without rules or umpires or penalties would simply mean the trampling of the weak by the strong. This would be a world in which selfishness would be supreme. There would be no respect for, and understanding of, the rights of others.

How Rules Began

How have many old customs—everyday customs—of life arisen? Why, in the wedding ceremony, is a ring used? Why is there a "best man"? Why are straw hats put away each year on the fifteenth day of September, rather than on the thirtieth? Why, in the United

States, do we lift our hats to the ladies? Why do drivers of wagons and automobiles in America use the right side of the road, but in England the left?

These common every-day customs and habits are rules which have been carried down through generations of people, from father to son, until today we do not even question them. They are part

of our daily life. In a great many cases they run back to a time before a record of the deeds and thoughts of man was kept.

Custom and Caste

In India customs have been carried to such an extreme as to separate the people of that great country into groups so distinct and so cut off from each other that a member of one group, usually called a *caste*, cannot marry into another. Differences between groups are

so sharp that members of one of these groups cannot eat with the members of another, cannot even touch the other's hand or garment without losing caste. In India an individual is *born* into his work, into his occupation, into a place in life, and he can never move into another place, because he belongs to a certain established caste.

How different the United States would be if every citizen belonged to a caste! If, because a boy's father was

A Command

LAW is a command of Government which says "Thou shalt," or "Thou shalt not" . . . Every resident of a community, whether a citizen or not, must obey the law . . . The law of the land must be upheld at all costs . . . The Government must execute the law as it is, not as individual citizens think it should be executed.



WHEN A PERSON COMES TO THIS COUNTRY, it is good for him to learn our customs. He thus saves himself a great deal of trouble. He should not

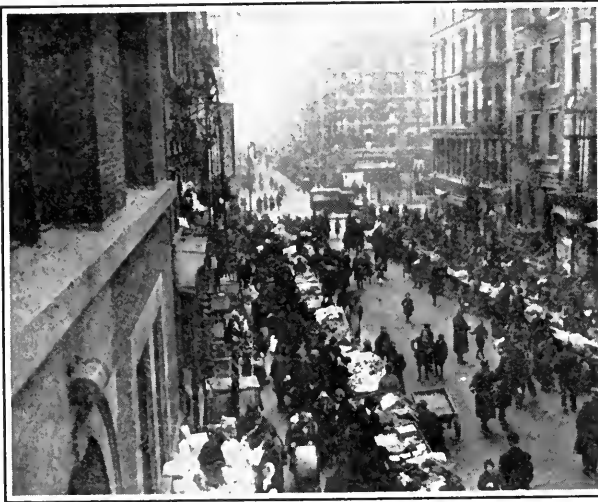

be content to live all the time in the FOREIGN QUARTERS OF A CITY. By mixing with Americans he will get to know their ways and soon he will



make friends and will be more successful in GETTING A JOB. Working in with the customs of a country will make life go more smoothly and agreeably for him. It is also in the interests of the United States that all should live in harmony with its customs and laws. There is another reason why one should learn the customs of a country in which he intends to live. By so doing he will have a better understanding of the laws of the country.

a bookkeeper, he too, by custom, must be a bookkeeper. What a queer country it would be if the daughters of carpenters were forced to marry only carpenters' sons! This is just the meaning of caste. In India these customs are obeyed more fully than many laws such as we have in the United States. Although we may laugh at these castes of India, we must remember that every nation has its own way of doing things and the customs of one race often seem foolish or outlandish to another race.

Do As the Romans Do

There is an old saying: "When in Rome do as the Romans do." This is simply another way of saying that one should respect the customs of others and not criticise those customs simply because they are different from our way of doing things. If you go to another country, it is generally a good thing to fit in with the customs of the people living there. You thus save yourself much time and avoid a great deal of trouble. This also applies to those who come to this country. Respecting the customs of others makes friends for you; makes it possible for you to secure work more easily. Working in harmony with the customs of a country makes life go more smoothly and far more agreeably in every way.

Custom and Law

When the government finds it necessary to back customs by force, by political action, then a custom becomes a law.

It might be that an old custom has become very bad for the

people to follow, and must be changed by law. On the other hand laws may have to be passed to meet new customs created by new conditions. In the latter case, for example, the new conditions created, in 1922, by the wide use of the *radio*, have compelled the Secretary of Commerce, Herbert C. Hoover, to hold conferences to find out if the Government's wireless sending and receiving stations are being interfered with by the activity of the thousands of enthusiastic radio fans throughout the country. Without doubt new laws will have to be passed to regulate the operation of radios in the homes.

Law is a command of government which says "THOU SHALT," or "THOU SHALT NOT," and imposes a penalty for its violation. It is the written will of the people with the force of the government behind it. Nearly everyone remembers being told about the laws of the Medes and the Persians which never changed. Today in modern democracies there are no laws of this character. Law should change as conditions of life change, in order to meet the new needs. *Law in a democracy grows out of public opinion, out of the views of a majority of the people.*

A few houses located at a cross road grow into a village; this village grows into a city, and possibly may become a great center of population like Chicago or Philadelphia or New York. As the change takes place, new laws have to be passed in order to meet the many new needs and new problems.



If one knows the customs or habits of a country, he understands, in a great measure, its laws. Customs or habits create laws. New laws are passed to take care of new customs that arise. The recent wide use of the radio, for example, has made the government, through its Secretary of Commerce, HERBERT C. HOOVER, call conferences to find out if new laws should be passed to regulate the use of the radio in



the homes. Law is a command of government which says, "THOU SHALT" and "THOU SHALT NOT," and imposes a penalty for its violation.



There are some laws that are called Constitutional or Fundamental Laws. In the United States such laws are found in the Federal Constitution or in the different state constitutions. In 1775 THE AMERICAN COLONISTS left their homes, farms and shops to fight for the fundamental right of a people to tax themselves through their own representatives. The

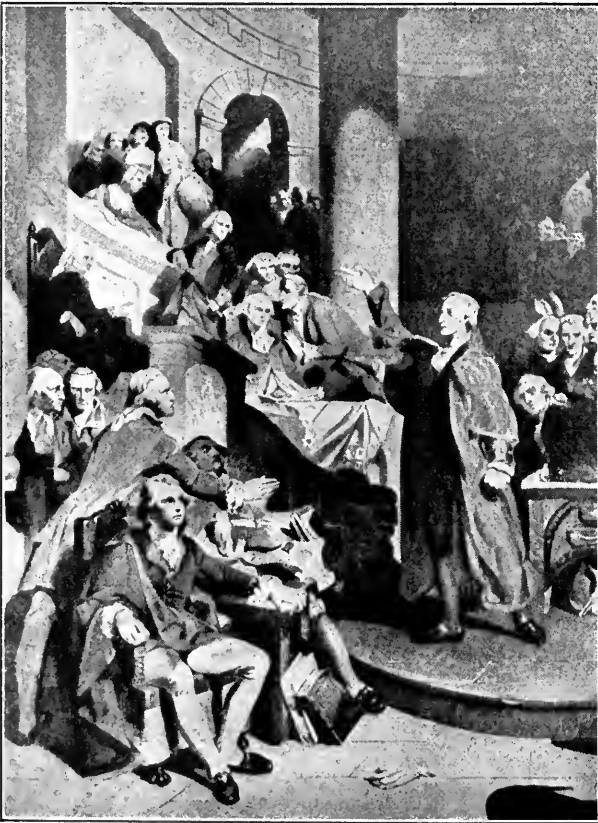

Virginia Bill of Rights, adopted at the Convention of Virginia, 1776, was the immediate forerunner of the Declaration of Independence, formally adopted July 4, 1776. PATRICK HENRY, an American patriot, delivered his famous speech in the Virginia Convention of 1775.

Constitutional Law

In order that people may live and work together successfully, there are a few rules absolutely essential in their nature. These laws are called Constitutional laws. We speak of them as the *fundamental laws of the land*.

In the United States such fundamental rules are found in the *Constitution* or in the different *state constitutions*. They are laws which protect us against the danger of oppression. They also organize the form of government in which we live and which has been described in chapter two. Many of the most important fundamental laws are found in a number of outstanding documents of England, such as:

The Magna Carta,
The Habeas Corpus Act,
The Bill of Rights.

Magna Carta, a great historical document given to the world in the year 1215, clearly states the rights of the individual against aggression on the part of a government. This document is one of the foundation stones of free, democratic and constitutional government. *The Habeas Corpus Act*, of the year 1679, is another landmark of human liberty. It clearly establishes the principle that "every human being who is not charged with or convicted of a known crime is entitled to personal liberty." *The Bill of Rights*, 1689, restates these principles of human liberty.

American Documents

America also has given many documents to the world which state principles of freedom. When the American colonists

in 1765 protested against royal oppression and the levying of taxes without representation they made a *Declaration of Rights and Grievances*. The *Virginia Bill of Rights*, 1776, was the immediate forerunner of the *Declaration of Independence*, unanimously and formally adopted July 4, 1776. This latter document is the American Magna Carta, and asserts the right of the people to form a constitution and a government of their own. *The Constitution of the United States*, in which the American Government is organized and its principles of liberty stated, has become a model the world over for new governments to copy. *The foundations of liberty and free government are to be found in all these great historic documents.*



The men, who in 1776 WROTE THE DECLARATION OF INDEPENDENCE, stated in this great document the right of a people to govern themselves. They fought for this right and won. The Constitution

The Organization of a Club

When you organize an athletic club or a debating society, one of the first things you do is to put in writing the purpose of the club, the names and duties of the officers, when the club is to hold its meetings, how much the dues are to be, and the rights and privileges of the individual members of the club. When you do this you write a constitution.

The constitution of a nation, such as the United States, fills the same need and meets the same purpose in your political life as this constitution of your athletic club does in your athletic life. Most countries today have a written constitution of this kind. It gives stability and purpose to the government.



of the United States has become a model the world over for new governments to copy. This picture is INDEPENDENCE HALL, Philadelphia. Here the Declaration of Independence was signed. Here Congress sat from 1778 until the close of the Revolution. Here, in 1787, the Federal Convention assembled to frame the Constitution of the United States.



This Constitution states among other things three fundamental laws. The first great fundamental law is the **RIGHT OF FREE SPEECH**. The second is the



RIGHT OF A FREE PRESS, and the third is the



RIGHT TO HOLD MEETINGS to discuss any matter that a group of citizens may wish to discuss. But no one may abuse these rights to the harm of the citizen or the government. It was for these rights that the **PILGRIM FATHERS** came to this country. The illustration shows their first meeting in America.

Bill of Rights

Every constitution of a country should contain three essential points. It usually states most clearly in the beginning the rights and the privileges of the individual citizen. Very often this is called the *Bill of Rights*. The Constitution of the United States, for example, as well as every individual state constitution, contains certain rights which are given to every citizen, such as the right to a *trial by jury* to those charged with crime. It also guarantees the right of *free speech*, a *free press*, and the right to *hold meetings* to discuss any matter which a group of citizens may wish to discuss.

Organization of Government

Every club or society must be organized; so must every government. Orderly government means one which works in an organized and regular manner. Every constitution states how the government is to be organized. The *National Constitution* and *state constitutions* show how Congress and the State Legislatures are to be made up, how their members are to be elected and how long they are to remain in office. These constitutions also tell what officials are to execute the law, indicate the requirements for and the length of the terms of such executives, and the manner of their selection.

Amending a Constitution

Constitutions must be changed from time to time to meet new conditions, otherwise there are likely to be violent disputes and revolution. Through changes in

constitutions (called amendments), the desires of the people are newly expressed from time to time as new needs arise in regard to what shall be the fundamental law of the land. Such amendments allow for progress in government.

It is dangerous to change a fundamental law too quickly. Our Constitution should not be amended unless a large majority of the people of the United States demand it, and not until time is given to think over the wisdom of the change proposed.

A good government is not always a government that changes too rapidly, or a government that meets every whim and fancy of the people. Individuals are fickle and change their minds very quickly. Constitutional changes should be made only after long and sober thought.

Statutory Law

Other laws are not so fundamental in their nature as are constitutional laws. There are many rules which are likely to need changes at frequent intervals. Laws of this character are left to Congress or a State Legislature to look after. They are called *Statutes*.

Everyone should have a clear idea of the difference between *Constitutional Law* and *Statutory Law*. *Constitutional Laws are fundamental, and can be changed or added to only through special amendment; Statutory Laws are not so fundamental, and so can be changed or added to when desired, by a simple act of the elected lawmakers, or, in some states, in special elections by the people themselves.*



The Constitution may be amended. The 16th Amendment, WHICH GAVE CONGRESS THE POWER TO LEVY AND COLLECT AN INCOME TAX was passed by the Legislatures of the several states; then by the 61st Congress, February 25, 1913.

YES	<input type="checkbox"/>	AMENDMENT NO. 1
NO	<input type="checkbox"/>	"Shall the proposed amendment to section nine of article five of the Constitution, extending the civil service to veterans of the Spanish and World Wars," be approved?

YES	<input type="checkbox"/>	AMENDMENT NO. 2
NO	<input type="checkbox"/>	"Shall the proposed amendment to section six of article three of the Constitution, which increases the salary of the legislature from fifteen hundred dollars to three thousand dollars," be approved?

YES	<input type="checkbox"/>	AMENDMENT NO. 3
NO	<input type="checkbox"/>	"Shall the proposed amendment to section one of article two of the constitution, providing that any person who is entitled to vote by attaining majority, by naturalization or otherwise, unless such person is a native born citizen, shall be required to read and write English; and authorizing the legislature to provide the manner in which soldiers' and sailors' children shall be educated," be approved?

YES	<input type="checkbox"/>	AMENDMENT NO. 5
NO	<input type="checkbox"/>	"Shall the proposed amendment to section eighteen of article six of the Constitution, providing that the courts and courts of domestic relations," be approved?

YES	<input type="checkbox"/>	AMENDMENT NO. 6
NO	<input type="checkbox"/>	"Shall the proposed amendment to section eight of article seven of the Constitution, providing that that portion of the old Erie canal lying between Rome and Mohawk," be approved?

YES	<input type="checkbox"/>	AMENDMENT NO. 7
NO	<input type="checkbox"/>	"Shall the proposed amendment to section eight of article seven of the Constitution, providing that that portion of the old Erie canal lying between the easterly portion of the counties of Herkimer and Oneida," be approved?

CONSTITUTIONAL AMENDMENTS, on the other hand, are, in many states, submitted directly by the State Legislature to the people for approval. There are other laws called Statutory Laws. These can be changed by a simple act of the elected lawmakers of a State Legislature, or in some states by the people themselves at a special or regular election.



Every citizen must obey the fundamental laws of his state and nation. He must obey statutory laws which have been passed at the CAPITOL by Congress,



or passed by the legislature of a state at the STATE CAPITOL, for example, of Texas. He must also obey local ordinances which have been passed by the local



law-making body at the CITY HALL. This is New York's City Hall.

Local Laws or Ordinances

In local communities, such as villages, counties and cities, many minor matters which apply to the daily conduct of the people of a community must be looked after by the local government. *Street traffic rules* are a good example. Certain streets in congested quarters in large cities are roped off for children to play in, and rules are made that vehicles cannot go through such "play streets." People living in tenements are not allowed to clutter up fire-escapes with bedding or boxes, since in case of fire this would hinder people from getting to the street. An influenza epidemic strikes a city. The Health Department must do everything possible to prevent street cars being overcrowded and it must quarantine the homes of people who have the *flu*. When the epidemic is over, these rules can be repealed. Such problems are local and often temporary in their nature.

In every village or city an individual will find, and will have to obey, a great many minor laws of this character. These rules are called *Local Ordinances*, and are rules made by a city department under power given by law. They are passed by a city council or by some other body of local officials.

Every citizen, then, must obey *fundamental laws* of the land which are found in the Constitutions. He must obey *statutory laws*, which have been passed by Congress or by state legislatures. He must also obey *local ordinances* which are designed to meet local needs.

Where New Laws Come From

Every legislature has all sorts of proposals made to it to put into law. Some may suggest that certain movie films are bad for children to see, and may urge the state to appoint a *commission* to censor such objectionable films. A group of working people, seeing the dangers of unprotected machinery in factories, may request the passage of a law making necessary the introduction of safety devices. A flood may have swept over a town and a bill be introduced to widen and deepen the river channel in question. An epidemic of typhoid fever breaks out in a city, and a bill is drawn up to build a new filtration plant. Congress may have appointed a committee to study some very complex question, such as *immigration* or *savings banks*, for the purpose of making a complete report and recommendations for a new law. Proposals flow in from every direction to a legislature.

Kinds of Law

Every citizen is subject to two kinds of law: *criminal* and *civil*. A crime is an offense against public security and peace. An individual who commits a crime has injured his state or his community, and must be punished by the state or community. Any person breaking a law is subject to arrest and punishment by the government. Penalties are attached to every law. If a person murders another, he may be electrocuted or imprisoned for life. If he breaks the traffic rules, he may be fined a few dollars or sent to jail for one day.

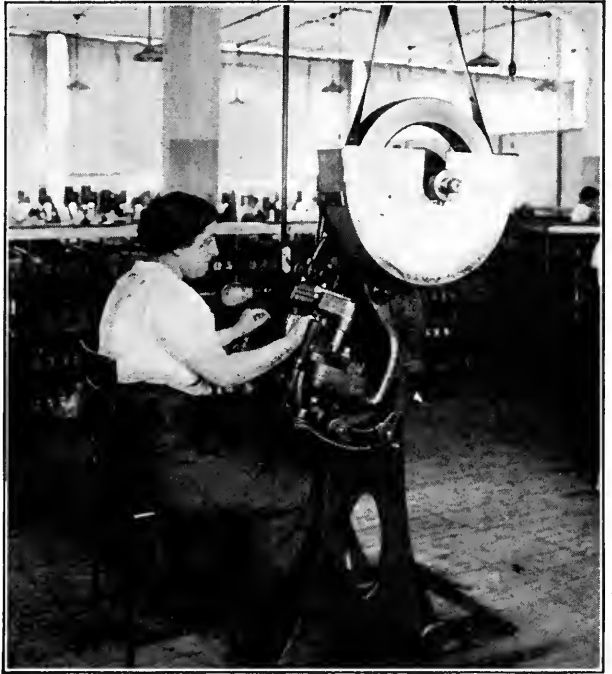

Every national, state or local legislature has all sorts of proposals made to enact into law. A group of working people, seeing the danger of unprotected machinery, may request the legislature of their state to pass a law making necessary the introduction of SAFETY DEVICES. . . . A FLOOD



HAS SWEEPED OVER A TOWN and a bill is introduced to widen and deepen the river channel. The



national legislature may have appointed a committee, such as a U. S. Senate Committee, to study some question as, for example, IMMIGRATION. Each of these measures may in time become law.



Every Citizen is subject to two kinds of law, criminal and civil. He who breaks a law must pay a penalty. If a person **BREAKS A TRAFFIC RULE**, he may be fined a few dollars or sent to jail for



one day. If his offence is greater, **HE MAY BE LOCKED UP IN JAIL FOR A LONG TIME.**



The highest court in the United States is **THE SUPREME COURT**. From its decisions there is no appeal. This court meets in the Capitol.

A Difficult Matter

Between these two extremes of sentences are hundreds of other laws, each with its individual punishment consisting of imprisonment, a fine, or the loss of the privilege of citizenship. It is a difficult matter at times to know what penalties should be attached to a crime. A penalty, if possible, should always fit the nature and magnitude of the crime.

When a person breaks a criminal law, he may be arrested by a police officer, if there is evidence that he has broken the law. Even a citizen may arrest the offender in case of threatened violence. *Warrants* or *permits* to arrest are required, however, for the more serious crimes. A warrant is issued by a court, after evidence has been given and sworn to that a certain named individual has committed a specified crime.

The *Grand Jury* is another body which may swear out warrants for the arrest of people who have committed serious crimes. It is a body of citizens who are called together to investigate the *evidence* of crimes. The district attorney or some other prosecuting official representing the state, presents the evidence and if the evidence is strong enough, the grand jury swears out a warrant charging an individual with the crime and orders his arrest.

Rights of the Accused

Constitutions, both State and Federal, guarantee an individual accused of crime certain rights and privileges. A citizen who is charged with felony (a serious crime with a penalty of imprison-

ment or worse), is entitled to a speedy trial by a jury. *The jury system is a most important part of American justice.* It secures for each individual accused of a crime a fair trial by his fellow citizens. A jury hears all the evidence and makes a decision on evidence given. It is generally composed of twelve individuals (in minor cases sometimes of six), and in order to convict, must give a unanimous opinion. If the verdict is not unanimous, another trial is given the accused unless the case is dropped.

An individual charged with a crime cannot be harshly treated. He is entitled to the services of a lawyer, is given the privilege of going free on giving bond that he will appear when required—except where extreme crime has been committed—and *is presumed to be innocent until found guilty.* In all criminal cases the state—the people who have been harmed—are represented by a district attorney or some other public official, while the accused is represented by his own lawyer. In case he has not enough money to pay for one, the state must see that the accused has a lawyer to defend him.

Civil Law

Many disputes arise among people over questions of contracts, or of money. One individual, for example, makes a contract with another to build a house. The contract is broken by the builder. He may be sued for damages on the part of the individual who has made the contract with him for the house. Possibly you have bought a home. After buying it you have discovered that you have not a clear title to the land upon which the house stands. You must take the question to court in order to determine who really owns the property. A child is run over and hurt or killed by an automobile. The parents of the child have the right to sue for damages. An individual dies without

a will and leaves property. The division of this property must be settled by the courts.

Criminal and Civil Law

All cases of this character come under the heading of *Civil Law*. Many acts, of course, are both *civil* and *criminal*. An automobile driver may have been reckless and broken the law and at the same time injured a person. He may be tried in a criminal court by the state, and he may at the same time be sued by the injured for damages.

Courts and judges have two purposes. In the first place they are organized to find out whether an individual has committed a crime, and if he has, to sentence him—to punish him. Courts are also organized to settle disputes between people over the question of personal and property rights. The first group of courts are called *Criminal Courts*, the second *Civil Courts*. Special courts, called *Probate* or *Surrogate Courts*, handle cases of inheritance or wills.

Constitutional Decisions

In the United States the courts have another important function to perform. Certain very fundamental rules are found in the Constitution of a State or of the United States, as has been shown before. *In America, courts determine whether any statute, law, or ordinance is in conflict with constitutional law.* This power is very important as it gives the court the task of guarding the constitution against assault by legislation. A law, if declared unconstitutional by a court, cannot be enforced.

Everyone, under all circumstances, should obey the laws. Every resident of a community, whether a citizen or not, should obey the laws. The laws of the land must be upheld at all costs. The government must execute the laws as they are, not as individual citizens think they should be executed.



©The American Viewpoint Society

Drawing by Hanson Booth

THE STATUE OF LIBERTY

The Constitution of the United States has been a beacon light for new nations

The Constitution of the United States

“The Most Wonderful Work Ever Struck Off at a Given Time by the Brain and Purpose of Man.”—Gladstone

WE HAVE LATELY MADE THE ACQUAINTANCE of a number of new states, among others, Poland, Jugo-Slavia, Hungary and Finland. We have seen these countries start out on stormy careers of independent statehood, struggling to throw off the many infant diseases that afflict most young nations and governments. Just as the life of a baby is often threatened, so the life of an infant nation is often in danger.

It is not an easy task, all mothers know, to raise babies. Statesmen, who may be looked upon as political mothers, find it just as difficult to raise nations to maturity. An infant state, born as the result of war, does not easily settle down under a permanent form of government that insures peace and prosperity to its citizens. These new countries and their experiences make this all too plain. Army factions, disgruntled leaders, debts and depreciated paper money, riots, dissatisfied soldiers, racial, political, class and religious prejudices, fanned to white heat, are just a few of the problems which new nations must settle before real stability is secured. Courage, statesmanship, toleration, and faith in the future are needed by these leaders who guide a newly launched *ship of state* on its first voyage.

Conditions After the Revolution

On October 19th, 1781, at Yorktown, Cornwallis surrendered to the combined American and French forces. This battle ended the *American Revolution for Independence*. The long struggle with England had been fought, and successfully concluded. The *Thirteen Original States* faced an independent

future in much the same condition as these new countries just mentioned.

While the war was on, economic conditions had become greatly demoralized. Finances had been neglected. Armies had marched back and forth from New England to the Carolinas leaving destruction behind. Paper money had been recklessly issued until the Colonists looked upon a piece of *Continental money* in much the same way that Austrians and Rus-

sians, since the World War, have looked upon *kronen* and *rubles*. “*Not worth a continental*” is still a saying in current use, which has come down from those early revolutionary days when paper money was so plentifully printed.

Many of the colonies and thousands of the colonists were badly in debt. Prices were high, life was disorganized, everything was in confusion, as the new nation of America began its independent career. Troubles immediately

Thirty Minutes

IT takes but thirty minutes to read “the oldest written instrument of Government in actual use.” There is no better way to know and to understand the **CONSTITUTION** of the **UNITED STATES** than to read it. No writer can explain it in more simple or concise language than is used in the **CONSTITUTION** itself...It is the foundation of American Government.



THE SURRENDER OF CORNWALLIS, at Yorktown, October, 1781, successfully ended the struggle for American Independence. The following six years mark the most critical period in American history.

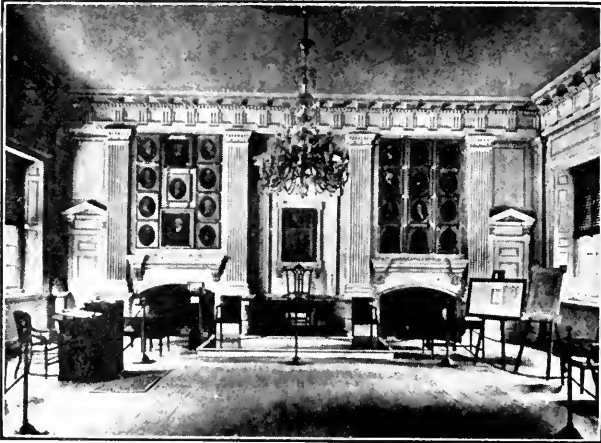

On May 25, 1787, the Constitutional Convention met in THIS ROOM in Independence Hall, Philadelphia, to create and organize a National Union. George Washington presided over the Convention. Finally the Constitution was written. . . .



The original manuscripts of the Declaration of Independence and the Constitution of the United States are in the custody of the LIBRARY OF CONGRESS.

blocked its path. Riots broke out in several parts of the country. Soldiers and officers, paid in depreciated paper money, were in bad financial straits and clamored for assistance. Individual states quarrelled with each other. The fires of sectional jealousy and antagonism, which had heretofore been kept under control through the stress of war, now that it was over, burst into flame. In despair, George Washington said of the situation: "*We act like one nation to-day and thirteen to-morrow.*"

Many Defects

The Government, at this time, and during the latter years of the war, consisted of a *Continental Congress* made up of delegates from the Original Thirteen States. This Congress operated under the provisions of the *Articles of Confederation*, a war constitution, adopted on November 15th, 1777. Under these Articles, in spite of their many defects, the States managed to stick together in their long struggle against the mother country.

But for peace purposes the Articles of Confederation proved impossible. The Continental Congress had little power. It had no power to collect taxes. The Government did not have an executive head—a *President*. The delegates were paid their salaries by individual states. They were elected for one year only. Congress lacked power, was unable to carry out its decisions, and soon fell into disrepute.

This has been called the critical period of American history; critical because the forces of disunion seemed to be getting the

upper hand. America needed a strong national state to bring law, order and *union* out of the existing chaos.

Discouragements at First

George Washington, James Madison, Alexander Hamilton, Benjamin Franklin, and others, realized the danger. They urged that action be taken. Virginia, taking the lead, sent an invitation to the other states to meet with her to discuss the situation. Only five states responded. The delegates met at Annapolis in 1786, but little progress was made.

Although very much discouraged and disappointed at the meager results, these leaders persisted in their efforts. Through their influence the Continental Congress then called a *Constitutional Convention*, made up of delegates representing the states. This Convention met in Philadelphia on May 25th, 1787.

The delegates to this Constitutional Convention were men experienced in public affairs, trained in law and practical politics, and well read. Many had been active in state government and had already held high executive or judicial positions. George Washington was elected *President* of this Convention and presided over its meetings.

Birth of the Constitution

The Convention faced many problems, but the fundamental one was to create and to organize a *National Union*, and to do this in spite of the jarring jealousies between individual states, and their general fears of a strong central government.

Many views regarding the form which the new government

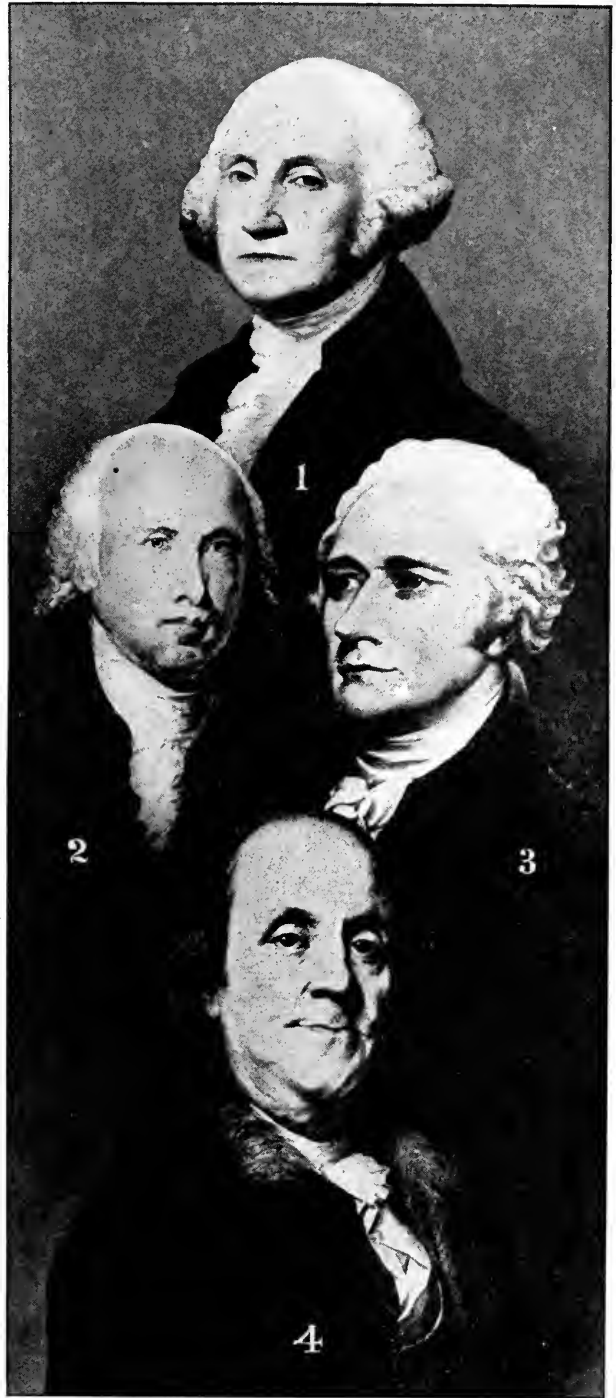

But it was necessary to have the written Constitution approved by the Delegates to the Constitutional Convention, and, finally, have each state ratify the work of the Delegates. After five months of debate all this was done. America owes much to THESE FOUR MEN and the others who were chiefly responsible for this great achievement.—(1) George Washington, (2) James Madison, (3) Alexander Hamilton and (4) Benjamin Franklin.

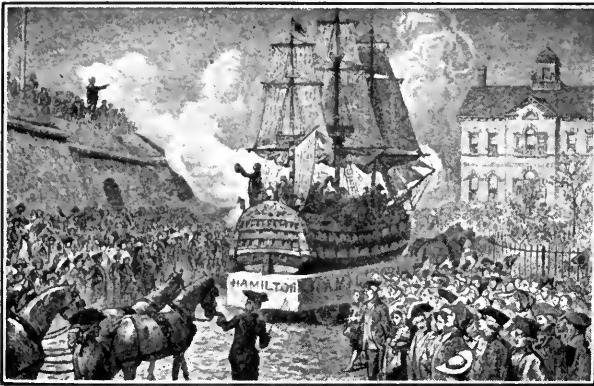

When the Constitution was ratified by the Delegates, there was great rejoicing. In New York City the celebration took the form of A MONSTER PARADE. Alexander Hamilton, whose name appears on the float, represented New York State at the Constitutional Convention. . . .



The United States Government was born on the 30th of April, 1789, when GEORGE WASHINGTON TOOK THE OATH OF OFFICE as our first President.



dent. THIS STATUE OF WASHINGTON, in front of the old Sub-treasury, New York City, marks the spot where Washington was inaugurated.

should take were presented. Several plans were outlined in detail by state delegations. The Constitutional Convention sat from May until September, and thoroughly discussed and debated these plans and suggestions. *The new Constitution for The United States of America was at last written and finally accepted and signed by the delegates on September 17th, 1787.*

Its Adoption by the States

Adoption by the Constitutional Convention, however, did not put the new government into actual operation. *Nine* of the thirteen states, according to the agreement of the delegates, had first to *ratify* the work of the Constitutional Convention. The proposed constitution was submitted to the vote of *state conventions* made up of special delegates.

A hot campaign followed. Many arguments were raised against the adoption of the new Constitution. Many even went so far as to denounce it. Washington, Franklin, Hamilton, Madison, Jay, Morris, and the other leaders of the day, stood firm and urged its acceptance.

The First President

This final fight was won at last. The Constitution was ratified by the required number of states. The new government was born. *On the 30th of April, 1789, George Washington took the oath of office as the first President of the United States of America, on the balcony of Federal Hall, which stood at the corner of Nassau and Wall Streets in New York City.*

Read It

This Constitution, which made the American people a nation, is *the oldest written constitution or complete instrument of government in actual use*. It is also the briefest and simplest. There is not an unnecessary word in it. With the illustrations, it does not fill over twenty pages of this book and takes but little more than the same number of minutes to read. Read it!

Gladstone, the great English statesman, thought this written instrument of government to be “*the most wonderful work ever struck off at a given time by the brain and purpose of man.*” Historians admit that it was the most democratic achievement of all history up to that time. It marks a milestone on the road to popular government and has been

a beacon light for new nations. Above all, *the Constitution has worked and stood the test of time.*

It was written to meet the needs of a little over three million white people, largely rural, living in a country in which only about *one hundred thousand square miles* were inhabited and which contained few rich and hardly any poor. The Constitution is now being applied to *3,743,448 square miles of territory*, including outlying possessions; to vastly different economic and social conditions, and to over *one hundred and seventeen million* men, women and children.

The United States, under the form of government outlined in its Constitution, has grown to be one of the most powerful, most prosperous, and most stable governments in the world!

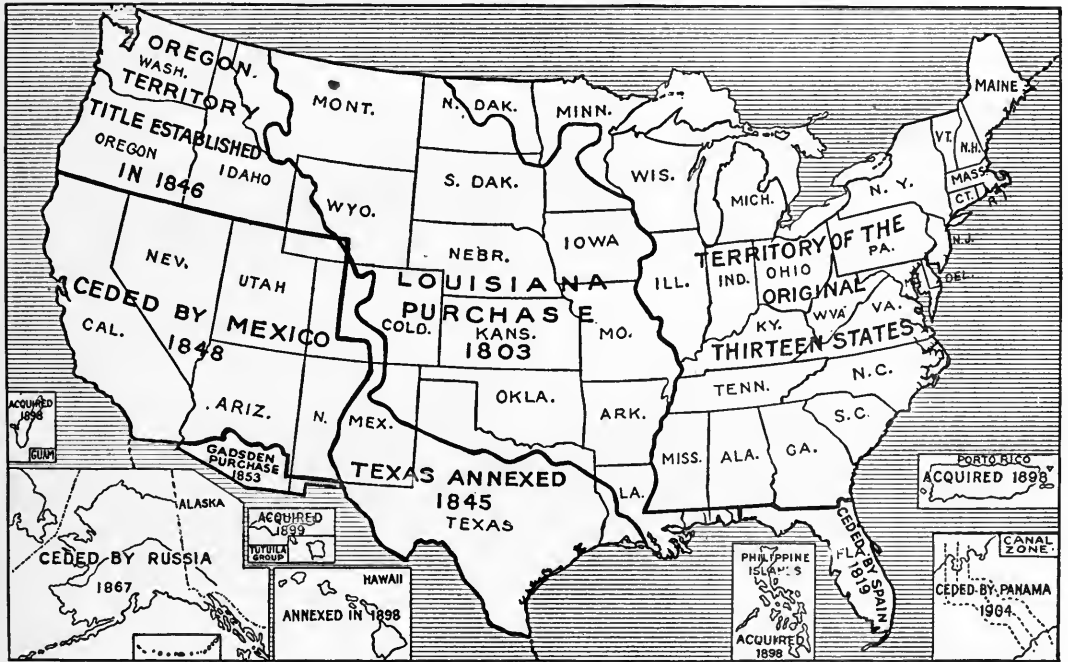

THE TERRITORIAL GROWTH OF THE UNITED STATES

The Constitution was written to meet the needs of a little over three million white people—living in a country in which only about one hundred thousand square miles were inhabited. It is now being applied to 3,743,448 square miles of territory and to 117,859,358 men, women and children.

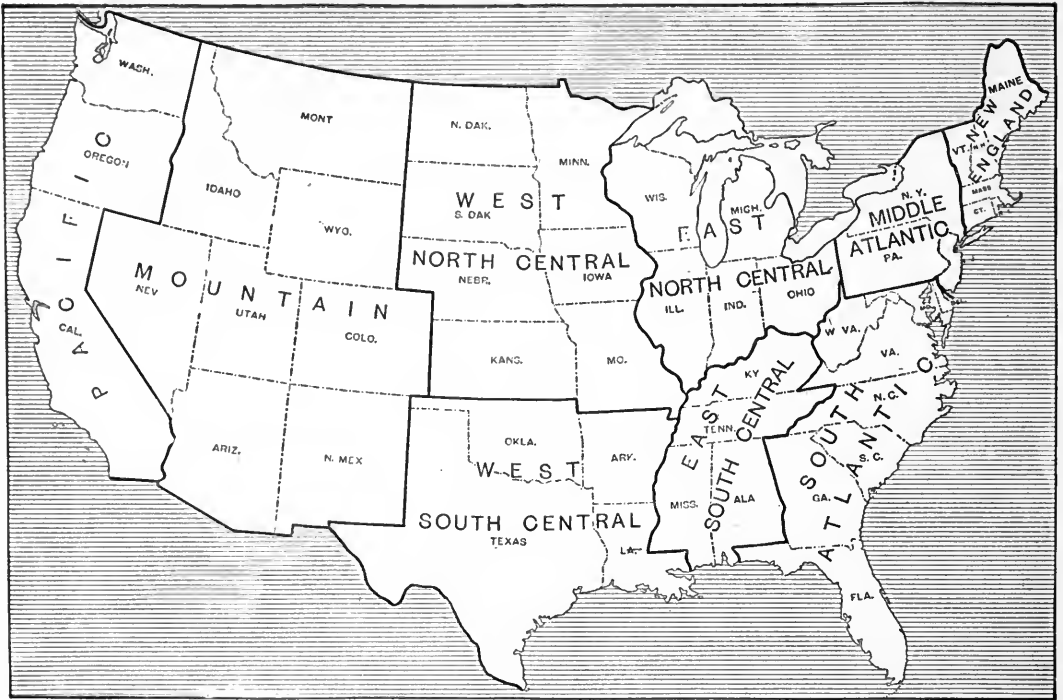

CONTINENTAL UNITED STATES OF AMERICA, SHOWING GEOGRAPHIC DIVISIONS
(AREA: 2,974,000 SQUARE MILES)

The Constitution of the United States of America

The Constitution originally consisted of a Preamble and seven Articles, and in that form was "*Done in Convention by the Unanimous Consent of the States present the Seventeenth Day of September in the Year of our Lord one thousand seven hundred and Eighty seven and of the Independence of the United States of America the Twelfth.*" The Constitution was declared in effect on the first Wednesday in March, 1789. The signers of the original Constitution, by virtue of their membership in Congress, were:

Go. WASHINGTON, *President and deputy from Virginia.* **New Hampshire**—John Langdon, Nicholas Gilman. **Massachusetts**—Nathaniel Gorham, Rufus King. **Connecticut**—Wm. Saml. Johnson, Roger Sherman. **New York**—Alexander Hamilton. **New Jersey**—Wil. Livingston, David Brearley, Wm. Patterson, Jona. Dayton. **Pennsylvania**—B. Franklin, Robt. Morris, Thos. Fitzsimons, James Wilson, Thomas Mifflin, Geo. Clymer, Jared Ingersoll, Gouv. Morris. **Delaware**—Geo. Read, John Dickinson, Jaco. Broom, Gunning Bedford Jun., Richard Bassett. **Maryland**—James McHenry, Dan. Carroll, Dan. Jenifer, of St. Thos. **Virginia**—John Blair, James Madison, Jr. **North Carolina**—Wm. Blount, Hu. Williamson, Richd. Dobbs Speight. **South Carolina**—J. Rutledge, Charles Pinckney, Charles Cotesworth Pinckney, Pierce Butler. **Georgia**—William Few, Abr. Baldwin. Attest: WILLIAM JACKSON, *Secretary.*

The Constitution was ratified by the Thirteen Original States in the following order:

Delaware, December 7, 1787, unanimously.
Pennsylvania, December 12, 1787, vote 46 to 23.
New Jersey, December 18, 1787, unanimously.
Georgia, January 2, 1788, unanimously.
Connecticut, January 9, 1788, vote 128 to 40.
Massachusetts, February 6, 1788, vote 187 to 168.
Maryland, April 28, 1788, vote 63 to 12.

South Carolina, May 23, 1788, vote 149 to 73.
New Hampshire, June 21, 1788, vote 57 to 46.
Virginia, June 25, 1788, vote 89 to 79.
New York, July 26, 1788, vote 30 to 28.
North Carolina, November 21, 1789, vote 193 to 75.
Rhode Island, May 29, 1790, vote 34 to 32.

The Preamble to the Constitution

We, the people of the United States, in order to form a more perfect Union, establish justice, insure domestic tranquillity, provide for the common defence, promote the general welfare, and secure the blessings of liberty to ourselves and our posterity, do ordain and establish this Constitution for the United States of America.

Article I. Legislative Department



THE CAPITOL AT WASHINGTON, D. C. HERE CONGRESS, COMPOSED OF THE SENATE AND THE HOUSE OF REPRESENTATIVES, MEETS

SECTION 1.—Legislative Powers of Congress

Congress

All legislative powers herein granted shall be vested in a Congress of the United States, which shall consist of a Senate and a House of Representatives.

The term of each Congress is two years. It assembles on the first Monday in December.

SECTION 2.—House of Representatives

Representatives: How Chosen

1. The House of Representatives shall be composed of members chosen every second year by the people of the several States, and the electors in each State shall have the qualifications requisite for electors of the most numerous branch of the State Legislature.

The Sixty-seventh Congress has 435 members in the House. The number of congressmen changes with each census.

Qualifications of a Representative

2. No person shall be a Representative who shall not have attained to the age of twenty-five years, and been seven years a citizen of the United States, and who shall not, when elected, be an inhabitant of that State in which he shall be chosen.

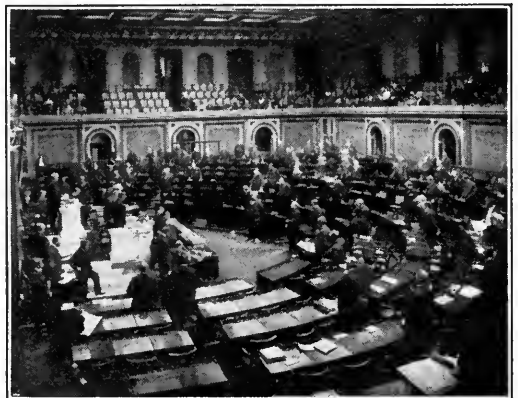

THE HOUSE OF REPRESENTATIVES

"The House of Representatives shall be composed of members chosen every second year by the people of the several states."—Par. 1, Sec. 2.



UNITED STATES CENSUS OFFICIALS

The number of Representatives from each state is determined by the population of each state, as shown by the census.—Par. 3, Sec. 2.



FREDERICK H. GILLETT, SPEAKER OF THE HOUSE SINCE 1919

"The House of Representatives shall choose their speaker and other officers."—Par. 5, Sec. 2

Representatives and Direct Taxes

3. Representatives and direct taxes shall be apportioned among the several States which may be included within this Union, according to their respective numbers,¹ which shall be determined by adding to the whole number of free persons, including those bound to service for a term of years, and excluding Indians not taxed, three fifths of all other persons.² The actual enumeration shall be made within three years after the first meeting of the Congress of the United States, and within every subsequent term of ten years, in such manner as they shall by law direct. The number of Representatives shall not exceed one for every thirty thousand, but each State shall have at least one representative; and until such enumeration shall be made, the State of New Hampshire shall be entitled to choose three, Massachusetts eight, Rhode Island and Providence Plantations one, Connecticut five, New York six, New Jersey four, Pennsylvania eight, Delaware one, Maryland six, Virginia ten, North Carolina five, South Carolina five, and Georgia three.

¹The apportionment under the census of 1910 is one representative for about 240,000 persons.

²The word "persons" refers to slaves. This paragraph has been amended (Amendments XIII and XIV) and is no longer in force.

Vacancies to be Filled

4. When vacancies happen in the representation from any State, the Executive authority thereof shall issue *writs of election*³ to fill such vacancies.

³Call a special election.

Powers of Choosing Officers, and of Impeachment

5. The House of Representatives shall choose their Speaker and other officers; and shall have the sole power of impeachment.

SECTION 3.—The Senate

Senators: How and by Whom Chosen

1. The Senate of the United States shall be composed of two Senators from each State, chosen by the Legislature thereof, for six Years; and each Senator shall have one Vote.⁴

⁴Senators are now elected by direct vote of the people. See Amendment XVII.

Senators: How Classified

2. Immediately after they shall be assembled in Consequence of the first Election, they shall be divided as equally as may be into three Classes. The Seats of the Senators of



THE SENATE CHAMBER

"The Senate of the United States shall be composed of two Senators from each state."—Par. 1, Sec. 3.

the first Class shall be vacated at the Expiration of the second Year, of the second Class at the Expiration of the fourth Year, and of the third Class at the Expiration of the sixth Year, so that one-third may be chosen every second Year; and if Vacancies happen by Resignation, or otherwise, during the Recess of the Legislature of any State, the Executive thereof may make temporary Appointments until the next Meeting of the Legislature, which shall then fill such Vacancies.¹

¹A vacancy now is filled by the Governor of the State appointing a new Senator, or calling a special election. See Amendment XVII.

Qualifications of a Senator

3. No Person shall be a Senator who shall not have attained to the Age of thirty Years, and been nine Years a Citizen of the United States, and who shall not, when elected, be an Inhabitant of that State for which he shall be chosen.

President of the Senate

4. The Vice President of the United States shall be President of the Senate, but shall have no Vote, unless they be equally divided.

President pro tem, and other Officers of the Senate—How Chosen

5. The Senate shall choose their other Officers, and also a President *pro tempore*,² in the Absence of the Vice President, or when he shall exercise the Office of President of the United States.

²For the time being.

Power to Try Impeachment

6. The Senate shall have the sole Power to try all Impeachments. When sitting for that Purpose, they shall be on Oath or Affirmation. When the President of the United States is tried, the Chief Justice shall preside: And no Person shall be convicted without the Concurrence of two-thirds of the Members present.

Sentence, in Cases of Impeachment

7. Judgment in Cases of Impeachment shall not extend further than to removal from Office, and disqualification to hold and enjoy any Office of honor, Trust or Profit under the United States: but the Party convicted shall nevertheless be liable and subject to Indictment, Trial, Judgment and Punishment, according to Law.

Vote for one!		UNITED STATES SENATOR	9
<input type="checkbox"/>	★	HARRY C. WALKER.....	Democrat
<input type="checkbox"/>	🦅	JAMES W. WADSWORTH, JR.....	Republican
<input type="checkbox"/>	🏭	JACOB PANKEN.....	Socialist
<input type="checkbox"/>	🏛️	ELLA A. BOOLE.....	Prohibition
<input type="checkbox"/>	👤	HARRY CARLSON.....	Social Labor
<input type="checkbox"/>	👨🌾	ROSE SCHNEIDERMAN.....	Farmer-Labor

NEW YORK CANDIDATES—U. S. SENATE
Senators are now elected by direct vote of the people.—
 See Amendment No. XVII to the Constitution.



THOMAS R. MARSHALL, PRESIDENT OF THE SENATE, 1913-1921
"The Vice President of the United States shall be President of the Senate."—Par. 4, Sec. 3.



JOHN MARSHALL, "THE EXPOUNDER OF THE CONSTITUTION", CHIEF JUSTICE, 1801-1835.
"When the President of the United States is tried, the Chief Justice shall preside."—Par. 6, Sec. 3.

SECTION 4.—Elections and Sessions



OPENING OF THE UNITED STATES CONGRESS, 1903

"The Congress shall assemble at least once in every year."—Par. 2, Sec. 4.

Times, etc., of Holding Elections

1. The Times, Places and Manner of holding Elections for Senators and Representatives, shall be prescribed in each State by the Legislature thereof; but the Congress may at any time by Law make or alter such Regulations, except as to the Places of chusing Senators.

When Congress Shall Meet

2. The Congress shall assemble at least once in every Year, and such Meeting shall be on the first Monday in December, unless they shall by Law appoint a different Day.

SECTION 5.—Government and Rules

Membership—Quorum, Etc.

1. Each House shall be the Judge of the Elections, Returns and Qualifications of its own Members, and a Majority of each shall constitute a Quorum¹ to do Business; but a smaller Number may adjourn from day to day, and may be authorized to compel the attendance of absent Members, in such Manner, and under such Penalties as each House may provide.

¹The number authorized to do business. In this case, one more than half the total number of members.

Rules of Proceedings—Powers to Punish

2. Each House may determine the Rules of its Proceedings;² punish its Members for disorderly Behaviour, and, with the Concurrence of two-thirds, expel a Member.

²Rules for the conduct of business.

CALENDAR OF HOUSE BILLS.
SIXTY-SIXTH CONGRESS.

House of Origin	By Whom Introduced	Title	Action
H. R. 61	Mr. Larkin, May 29, 1919	To prohibit immigration for a period of four years, and for other purposes.	
H. R. 583	Mr. Johnson of Washington, May 19, 1919	To provide for the protection of the citizens of the United States by the temporary suspension of immigration, for the deprivation of additional chance of admission, for the registration of alien, to promote the assimilation of alien, to further regulate the immigration of alien to, and the residence of alien in, the United States, to amend the provisions of the immigration act relating to alien names, and for other purposes.	
H. R. 1104	Mr. Baker, May 20, 1919	To prohibit the coming of Asiatic laborers into the United States, and in other purposes.	
H. R. 1105	Mr. Baker, May 20, 1919	To prohibit immigration for a period of four years, and for other purposes.	
H. R. 1240	Mr. Kierkels, May 20, 1919	To exempt and exclude from the United States certain undesirable alien.	Considered in connection with H. R. 10310.
	Mr. Dillinger, 1919	Transmitted over 1 of the 61st June 29, 1904, as amended by the act of May 9, 1916, relative to the naturalization of alien born up to the terms of the Alien duty and exclude from the United States.	Oct. 9, 1919.—House Considered.

REDUCED FAC-SIMILE OF CALENDAR OF HOUSE BILLS ON IMMIGRATION, SIXTY-SIXTH CONGRESS

Each house may determine the rules of its proceedings.—Par. 2, Sec. 5.



REDUCED FAC-SIMILE, COVER PAGE, CONGRESSIONAL RECORD

"Each house shall keep a journal of its proceedings and from time to time publish the same except in such parts as may in their judgment require secrecy."—Par. 3, Sec. 5.

Journal of Proceedings

3. Each House shall keep a Journal of its Proceedings, and from time to time publish the same, excepting such Parts as may in their Judgment require Secrecy;³ and the Yeas and Nays of the Members of either House on any question shall, at the Desire of one-fifth of those Present, be entered on the Journal.

³For example: news in time of war.

Adjournment of Congress

4. Neither House, during the Session of Congress, shall, without the Consent of the other, adjourn for more than three days, nor to any other Place than that in which the two Houses shall be sitting.

SECTION 6.—Privileges and Restrictions of Members

Pay and Privileges of Members

1. The Senators and Representatives shall receive a *compensation for their services*,¹ to be ascertained by law, and paid out of the Treasury of the United States. They shall in all cases, except treason, felony, and breach of the peace, be privileged from arrest during their attendance at the session of their respective Houses, and in going to and returning from the same; and for any speech or debate in either House they shall not be questioned in any other place.

¹Seventy-five hundred dollars a year and twenty cents for every mile of travel each way from their homes at each annual session.

Prohibitions on Members

2. No Senator or Representative shall, during the time for which he was elected, be appointed to any civil office under the authority of the United States, which shall have been created, or the emoluments whereof shall have been increased, during such time; and no person holding any office under the United States shall be a member of either House during his continuance in office.



DANIEL WEBSTER "DEFENDER OF THE CONSTITUTION," SPEAKING IN THE SENATE

For any speech or debate in either house a Senator or Representative shall not be questioned in any other place.—Par. 2, Sec. 6.

SECTION 7.—Method of Passing Laws

Revenue Bills

1. All bills for raising revenue shall originate in the House of Representatives; but the Senate may propose or concur with amendments as on other *bills*.²

²A bill is a written statement or proposal offered to be made into law.

How Bills Become Laws

2. Every bill which shall have passed the House of Representatives and the Senate shall, before it become a law, be presented to the President of the United States; if he approve he shall sign it, but if not he shall return it with his objections to that House in which it shall have originated, who shall enter the objections at large on their journal, and proceed to reconsider it. If after such reconsideration two thirds of that House shall agree to pass the bill, it shall be sent, together with the objections, to the other House, by which it shall likewise be reconsidered, and if approved by two thirds of that House, it shall become a law. But in all such cases the votes of both Houses shall be determined by yeas and nays, and the names of the persons voting for and against the bill shall be entered on the journal of each House re-

49th CONGRESS, In SENATE. **S. 4528.**

IN THE SENATE OF THE UNITED STATES.
December 7, 1896.

Mr. KERR introduced the following bill, which was read (twice) and referred to the Committee on Immigration.

A BILL

To provide for the temporary suspension of immigration, and for other purposes.

Be it enacted by the Senate and House of Representatives of the United States of America in Congress assembled,

49th CONGRESS, In SENATE. **H. R. 7.**

IN THE HOUSE OF REPRESENTATIVES.
April 11, 1897.

Mr. TORNEY introduced the following bill, which was referred to the Committee on Education and ordered to be printed.

A BILL

To create a Department of Education, to authorize appropriations for the conduct of said department, to authorize the appropriation of money to encourage the States in the promotion and support of education, and for other purposes.

¹ *Be it enacted by the Senate and House of Representatives of the United States of America in Congress assembled,*

FAC-SIMILES OF (1) SENATE IMMIGRATION BILL, AND (2) HOUSE BILL "TO CREATE A DEPARTMENT OF EDUCATION"

All bills for raising revenue shall originate in the House of Representatives.—Par. 1, Sec. 7.



PRESIDENT HARDING SIGNING A BILL

"Every bill which shall have passed the House of Representatives and the Senate shall, before it become a law, be presented to the President of the United States. If he approve he shall sign it."—Par. 2, Sec. 7.

spectively. If any bill shall not be returned by the President within ten days (Sundays excepted) after it shall have been presented to him, the same shall be a law, in like manner as if he had signed it, unless the Congress by their adjournment prevent its return, in which case it shall not be a law.

Resolutions, etc.

3. Every order, resolution, or vote to which the concurrence of the Senate and House of Representatives may be necessary (except on a question of adjournment) shall be presented to the President of the United States; and, before the same shall take effect, shall be approved by him, or, being disapproved by him, shall be repassed by two thirds of the Senate and House of Representatives, according to the rules and limitations prescribed in the case of a bill.

SECTION 8.—Powers Granted to Congress

The Congress Shall Have Power:

To lay and collect taxes, duties,¹ imposts, and excises,² to pay the debts and provide for the common defense and general welfare of the United States; but all duties, imposts, and excises shall be uniform throughout the United States;

¹Duties: money paid on goods brought into this country.
²Imposts and excises: money paid on certain goods made in this country.

To borrow money on the credit of the United States;

To regulate commerce with foreign nations, and among the several States, and with the Indian tribes;

To establish a uniform rule of naturalization, and uniform laws on the subject of bankruptcies throughout the United States;

To coin money, regulate the value thereof, and of foreign coin, and fix the standard of weights and measures;

To provide for the punishment of counterfeiting the securities and current coin of the United States;

To establish post-offices and post-roads;

To promote the progress of science and useful arts, by securing, for limited times, to authors and inventors the exclusive right to their respective writings and discoveries;



ALIENS RENOUNCING ALLEGIANCE TO THEIR FORMER COUNTRIES AND RULERS

"The Congress shall have power to establish a uniform rule of naturalization."—Par. 4, Sec. 6.



UNITED STATES MARINE GUARDING MAIL

"The Congress shall have power to establish post-offices."—Par. 7, Sec. 8.

To constitute tribunals inferior to the Supreme Court;

To define and punish piracies and felonies committed on the high seas, and offenses against the law of nations;

To declare war, grant letters of marque and reprisal,¹ and make rules concerning captures on land and water;

¹Letters granted by the government to private citizens in time of war authorizing them, under certain conditions, to capture the ships of the enemy.

To raise and support armies, but no appropriation of money to that use shall be for a longer term than two years;

To provide and maintain a navy;

To make rules for the government and regulation of the land and naval forces;

To provide for calling forth the militia² to execute the laws of the Union, suppress insurrections and repel invasions.

²Militia: citizen soldiers.

To provide for organizing, arming, and disciplining the militia, and for governing such part of them as may be employed in the service of the United States, reserving to the States respectively the appointment of the officers, and the authority of training the militia according to the discipline prescribed by Congress;

To exercise exclusive legislation in all cases whatsoever over such district (not exceeding ten miles square) as may, by cession of particular States, and the acceptance of Congress, become the seat of the government of the United States,³ and to exercise like authority over all places purchased by the consent of the Legislature of the State in which the same shall be, for the erection of forts, magazines, arsenals, dockyards, and other needful buildings;—And

To make all laws which shall be necessary and proper for carrying into execution the foregoing powers, and all other powers vested by this Constitution in the government of the United States, or in any department or officer thereof.

³The District of Columbia.



SOLDIERS OF THE UNITED STATES ARMY

"The Congress shall have power to raise and support Armies."—Par. 12, Sec. 8.

... "To provide for calling forth the militia."—Par. 15, Sec. 8.

"To provide for organizing, arming, and disciplining the militia."—Par. 16, Sec. 8.

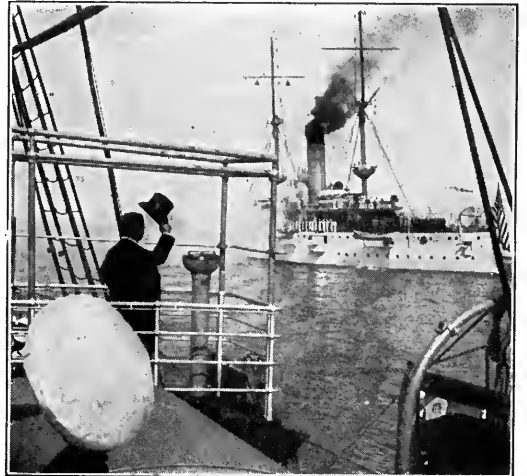

THE AMERICAN NAVY SALUTES ITS FORMER COMMANDER-IN-CHIEF, THE LATE PRESIDENT ROOSEVELT

"The Congress shall have power to provide and maintain a Navy."—Par. 13, Sec. 8.

SECTION 9.—Powers Denied to Congress

Migration or Importation

1. The migration or importation of such persons as any of the States now existing shall think proper to admit, shall not be pro-

hibited by the Congress prior to the year one thousand eight hundred and eight, but a tax or duty may be imposed on such importation, not exceeding ten dollars for each person.⁴

⁴An immigrant to the United States must pay a tax of eight dollars (\$8)

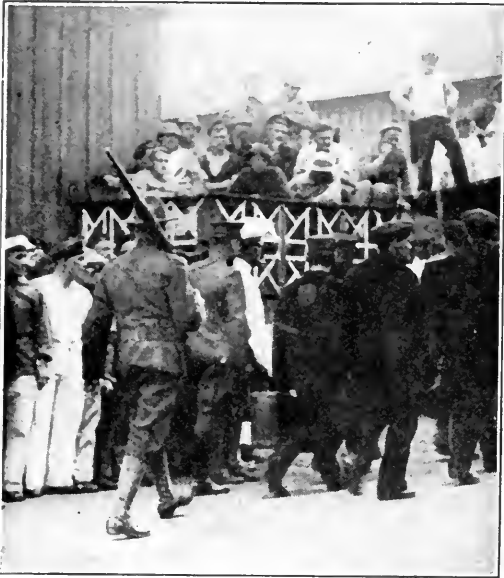

U. S. WAR DETENTION CAMP

"The privilege of the writ of *habeas corpus* shall not be suspended unless when in cases . . . the public safety may require it."—Par. 2, Sec. 9.

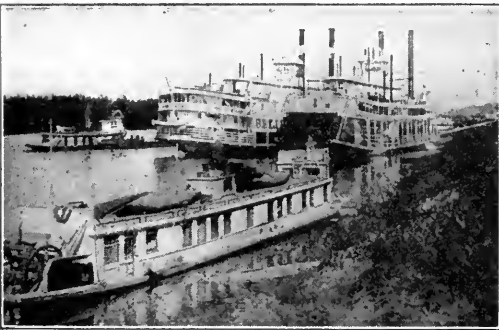

MISSISSIPPI RIVER STEAMERS

"Vessels bound to, or from, one State, shall not be obliged to enter, clear, or pay duties in another."—Par. 6, Sec. 9.

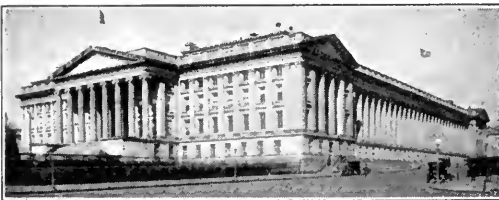

UNITED STATES TREASURY

"No money shall be drawn from the Treasury but in consequence of appropriations made by law."—Par. 7, Sec. 9.

SECTION 10.—Powers Denied to the States

Absolute Prohibitions

1. No State shall enter into any treaty, alliance, or confederation; grant letters of marque and reprisal; coin money; emit bills

Habeas Corpus

2. The privilege of the writ of *habeas corpus*¹ shall not be suspended, unless when in cases of rebellion or invasion the public safety may require it.

¹An official document requiring an accused person who is detained awaiting trial to be brought into court to inquire whether he may be legally held.

Bills of Attainder

3. No *bill of attainder*² or *ex post facto* law³ shall be passed.

²A special legislative act by which a person may be condemned to death or to outlawry or banishment without the opportunity of defending himself which he would have in a court of law.

³A law relating to the punishment of acts committed before the law was passed.

Taxes, How Apportioned

4. No *capitation*⁴ or other direct tax shall be laid, unless in proportion to the census or enumeration herein before directed to be taken.

⁴A tax levied per head...In 1913 the XVI Amendment gave Congress power to tax incomes.

No Export Duty

5. No tax or duty shall be laid on articles exported from any State.

No Commercial Preference

6. No preference shall be given by any regulation of commerce or revenue to the ports of one State over those of another; nor shall vessels bound to, or from, one State, be obliged to enter, clear, or pay duties in another.

Money: How Drawn from Treasury

7. No money shall be drawn from the Treasury, but in consequence of appropriations made by law; and a regular statement and account of the receipts and expenditures of all public money shall be published from time to time.

No Title of Nobility

8. No title of nobility shall be granted by the United States; and no person holding any office of profit or trust under them, shall without the consent of the Congress, accept of any present, emolument, office, or title, of any kind whatever, from any king, prince, or foreign state.

of credit; make anything but gold and silver coin a tender in payment of debts; pass any bill of attainder, *ex post facto* law, or law impairing the obligation of contracts, or grant any title of nobility.

Conditional Prohibitions

2. No State shall, without the consent of the Congress, lay any imposts or duties on imports or exports, except what may be absolutely necessary for executing its inspection laws; and the net produce of all duties and imposts, laid by any State on imports or exports, shall be for the use of the Treasury of the United States; and all such laws shall be subject to the revision and control of the Congress.

No State shall, without the consent of Congress, lay any duty of tonnage,¹ keep troops² or ships of war in time of peace, enter into any agreement or compact with another State, or with a foreign power, or engage in war, unless actually invaded, or in such imminent danger as will not admit of delay.

¹Lay any duty on shipping coming within their borders.

²Other than its militia.

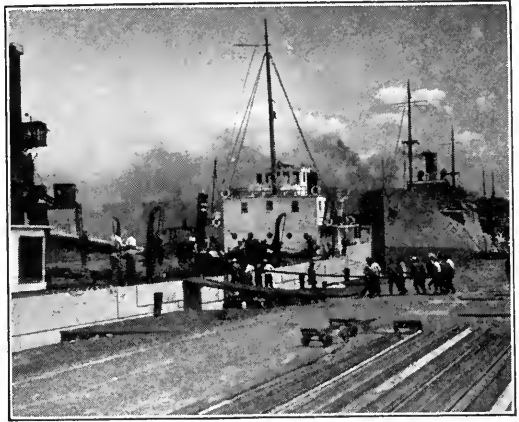

EXPORTING RAILS FROM CLEVELAND TO CANADA

"No state shall, without the consent of Congress, lay any imposts or duties on imports or exports, except what may be absolutely necessary for executing its inspection laws."—Par. 2, Sec. 2.

Article II. Executive Department

SECTION 1.—President and Vice-President

President: His Term of Office

1. The executive power shall be vested in a President of the United States of America. He shall hold his office during the term of four years, and, together with the Vice-President, chosen for the same term, be elected, as follows:

President: How Chosen

2. Each State shall appoint, in such manner as the Legislature thereof may direct, a number of electors, equal to the whole number of senators and representatives to which the State may be entitled in the Congress; but no senator or representative, or person holding an office of trust or profit under the United States, shall be appointed an elector.

[The electors shall meet in their respective States, and vote by ballot for two persons, of whom one at least shall not be an inhabitant of the same State with themselves. And they shall make a list of all the persons voted for, and of the number of votes for each; which list they shall sign and certify and transmit sealed to the seat of the government of the United States, directed to the president of the Senate. The president of the Senate shall, in the presence of the Senate and House of Representatives, open all the certificates, and the votes shall then be counted. The person having the greatest number of votes shall be the President, if such number be a majority of the whole number of electors appointed; and if there be



THE WHITE HOUSE—THE OFFICIAL HOME OF THE PRESIDENT OF THE UNITED STATES

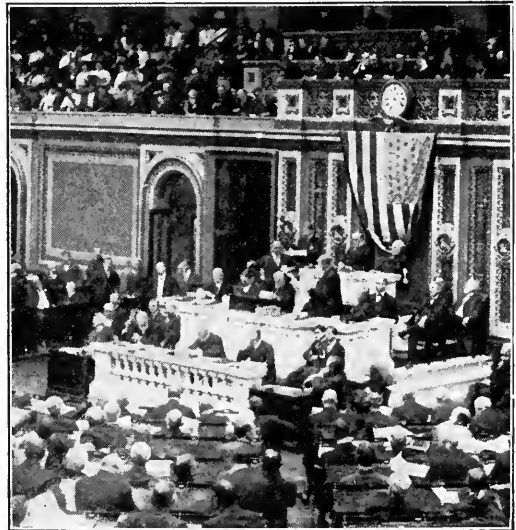

COUNTING THE PRESIDENTIAL ELECTORAL VOTE

"The President of the Senate shall, in the presence of the Senate and the House of Representatives, open all the certificates, and the votes shall then be counted."—Par. 2, Sec. 1.



**THE PRESIDENT AND MRS. HARDING,
VICE PRESIDENT AND MRS. COOLIDGE**
Warren Gamaliel Harding was born November 2, 1865, near Blooming Grove, Morrow County, Ohio. Calvin Coolidge was born July 4, 1872, at Plymouth, Vt. . . . "No person except a natural born citizen . . . shall be eligible to the office of President . . . or Vice President."—Par. 4, Sec. 1.

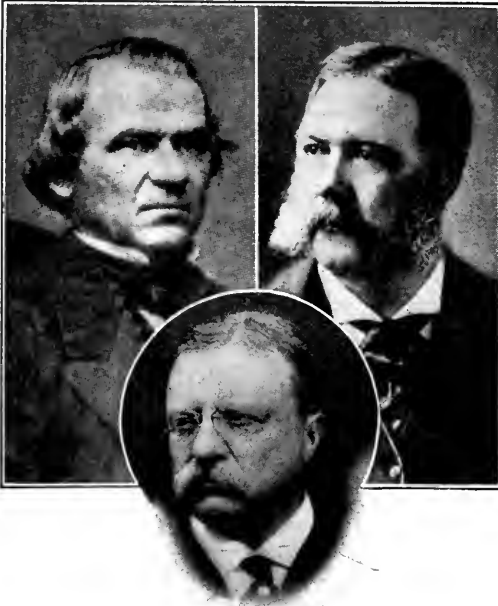

VICE PRESIDENTS WHO BECAME PRESIDENTS

"In case of . . . the death of the President . . . the same shall devolve on the Vice President."—Par. 5, Sec. 1, Andrew Johnson became President on the death of Abraham Lincoln; Chester Alan Arthur, on the death of James Abram Garfield; Theodore Roosevelt, on the death of William McKinley.

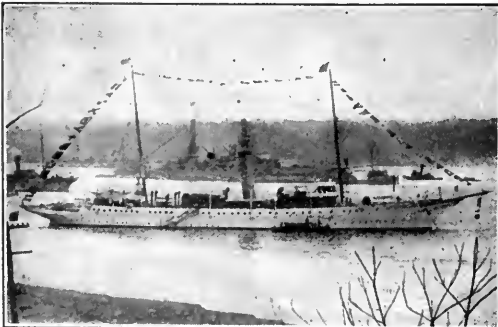

PRESIDENTIAL YACHT, THE MAYFLOWER
The salary of the President is now \$75,000 a year. In addition, he receives \$25,000 for traveling expenses, the use of "The Mayflower", The White House, etc.—Par. 6, Sec. 1.

more than one who have such majority, and have an equal number of votes, then the House of Representatives shall immediately choose by ballot one of them for President; and if no person have a majority, then from the five highest on the list the said house shall, in like manner, choose the President. But in choosing the President, the votes shall be taken by States, the representation from each State having one vote; a quorum for this purpose shall consist of a member or members from two-thirds of the States, and a majority of all the States shall be necessary to a choice. In every case, after the Choice of the President, the Person having the greatest Number of Votes of the Electors shall be the Vice-President. But if there should remain two or more who have equal Votes, the Senate shall choose from them by Ballot the Vice-President.^{1]}

¹This paragraph in brackets has been superseded by Amendment XII.

Electors to Vote on Same Day

3. The Congress may determine the Time of choosing the Electors, and the Day on which they shall give their Votes; which Day shall be the same throughout the United States.

Qualification of President

4. No Person except a natural born Citizen, or a citizen of the United States, at the time of the Adoption of this Constitution, shall be eligible to the Office of President; neither shall any Person be eligible to that Office who shall not have attained to the Age of thirty-five Years, and been fourteen Years a Resident within the United States.

In Case of Death

5. In Case of the Removal of the President from Office, or of his Death, Resignation, or Inability to discharge the Powers and Duties of the said Office, the same shall devolve on the Vice-President, and the Congress may by Law provide for the Case of Removal, Death, Resignation, or Inability, both of the President and Vice-President, declaring what Officer shall then act as President, and such Officer shall act accordingly, until the Disability be removed, or a President shall be elected.

President's Compensation

6. The President shall, at stated Times, receive for his Services, a Compensation, which shall neither be increased nor diminished during the Period for which he shall have

been elected, and he shall not receive within that Period any other Emolument from the United States, or any of them.

His Oath of Office

7. Before he enter on the execution of his office, he shall take the following oath or

affirmation:—“I do solemnly swear (or affirm) that I will faithfully execute the office of President of the United States, and will to the best of my ability, preserve, protect and defend the Constitution of the United States.”

SECTION 2.—Powers of the President

Commander-in-Chief

1. The President shall be commander-in-chief of the army and navy of the United States, and of the militia of the several States, when called into the actual service of the United States; he may require the opinion, in writing, of the principal officer in each of the *executive departments*,¹ upon any subject relating to the duties of their respective offices, and he shall have power to grant reprieves and pardons for offenses against the United States, except in cases of impeachment.

¹There are ten executive departments; each has a secretary. Altogether they form the President's Cabinet



COMMANDER-IN-CHIEF

“The President shall be Commander-in-chief of the Army and Navy of the United States, and of the Militia of the several states.”—Par. 1, Sec. 2.

Treaty Making Power

2. He shall have power, by and with the advice and consent of the Senate, to make treaties, provided two thirds of the Senators present concur; and he shall nominate, and, by and with the advice and consent of the Senate, shall appoint ambassadors, other public ministers, and consuls, judges of the Supreme Court, and all other officers of the United States, whose appointments are not herein otherwise provided for, and which shall be established by law; but the Congress may by law vest the appointment of such inferior officers, as they think proper, in the President alone, in the courts of law, or in the heads of departments.

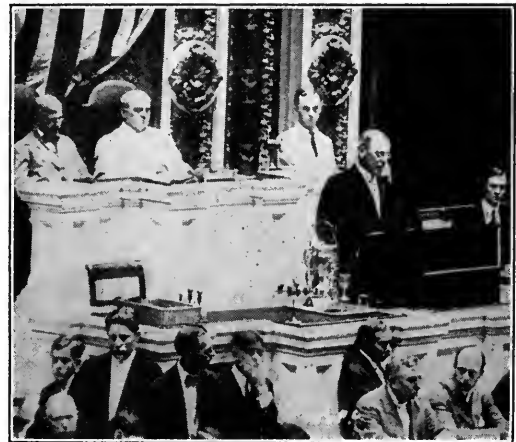

FORMER PRESIDENT WILSON DELIVERING A MESSAGE TO CONGRESS

“The President shall from time to time, give to the Congress information of the state of the Union.”—Par. 3, Sec. 2.

Power to Fill Vacancies

3. The President shall have power to fill up all vacancies that may happen during the recess of the Senate, by granting commissions which shall expire at the end of their next session.

SECTION 3.—Duties of the President

Message to Congress

He shall from time to time give to the Congress Information of the State of the Union, and recommend to their Consideration such Measures as he shall judge necessary and expedient; he may, on extraordinary Occasions, convene both Houses, or either of

them, and in Case of Disagreement between them, with Respect to the Time of Adjournment, he may adjourn them to such Time as he shall think proper; he shall receive Ambassadors and other public Ministers; he shall take Care that the Laws be faithfully executed, and shall Commission all the Officers of the United States.

SECTION 4.—Civil Offices Forfeited for Certain Crimes

Impeachment

The President, Vice-President and all civil Officers of the United States, shall be re-

moved from Office on Impeachment for, and Conviction of, Treason, Bribery, or other high Crimes and Misdemeanors.

Article III. Judicial Department

SECTION 1.—United States Courts—Supreme and Inferior

Judicial Powers

The judicial power of the United States shall be vested in one Supreme Court, and in such inferior courts as the Congress may from time to time ordain and establish. The

judges, both of the Supreme and inferior courts, shall hold their offices during good behavior, and shall, at stated times, receive for their services a compensation which shall not be diminished during their continuance in office.

SECTION 2.—Powers and Jurisdiction of the Federal Courts

The Judicial Power

1. The judicial Power shall extend to all Cases, in Law and Equity, arising under this Constitution, the Laws of the United States, and Treaties made, or which shall be made, under their Authority;—to all cases affecting Ambassadors, other public Ministers and Consuls;—to all cases of admiralty and maritime Jurisdiction;—to Controversies to which the United States shall be a Party;—to Controversies between two or more States;—between a State and Citizens of another State;—between Citizens of different States;—between Citizens of the same State claiming Lands under Grants of different States, and between a State, or the Citizens thereof, and foreign States, Citizens or Subjects.

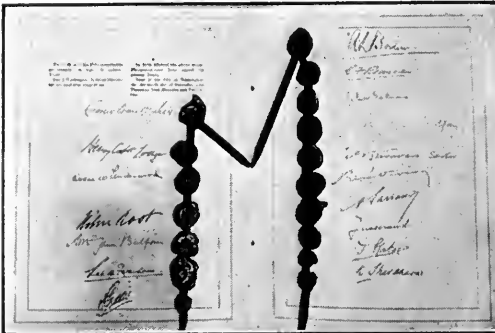

SIGNATURES TO THE "FOUR-POWER PACIFIC TREATY"

At the close of the Conference on the Limitation of Armament, a treaty was signed December 13, 1921, by the United States, England, France and Japan applying to relations in the Pacific. All treaties are a part of the supreme law of the United States and stand on a par with the Constitution and other laws.—Par. 1, Sec. 2.

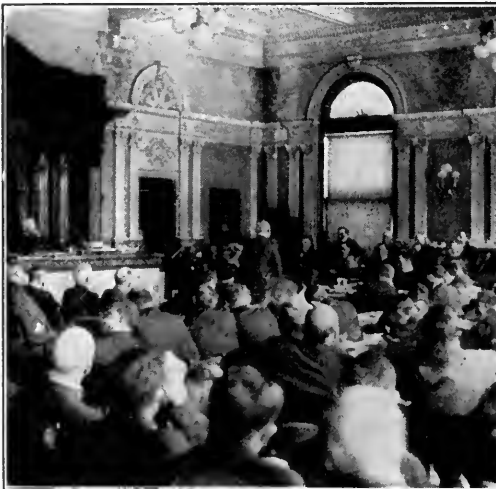

A UNITED STATES COURT IN SESSION
"The trial of all crimes, except in cases of impeachment, shall be by jury."—Par. 3, Sec. 2.

Original Jurisdiction

2. In all cases affecting ambassadors, other public ministers, and consuls, and those in which a State shall be party, the Supreme Court shall have original jurisdiction. In all the other cases before mentioned the Supreme Court shall have appellate jurisdiction, both as to law and fact, with such exceptions and under such regulations as the Congress shall make.

Trial by Jury

3. The trial of all crimes, except in cases of impeachment, shall be by jury; and such trial shall be held in the State where the said crimes shall have been committed; but when not committed within any State the trial shall be at such place or places as the Congress may by law have directed.

SECTION 3.—Treason: Its Nature and Punishment

Treason Defined

1. Treason against the United States shall consist only in levying war against them, or in adhering to their enemies, giving them aid and comfort. No person shall be convicted of treason unless on the testimony of two witnesses to the same overt act, or on confession in open court.

Punishment of Treason

2. The Congress shall have power to declare the punishment of treason, but no attainder of treason shall work corruption of blood or forfeiture except during the life of the person attainted.¹

¹Punishment for treason shall not affect anyone but the person convicted.

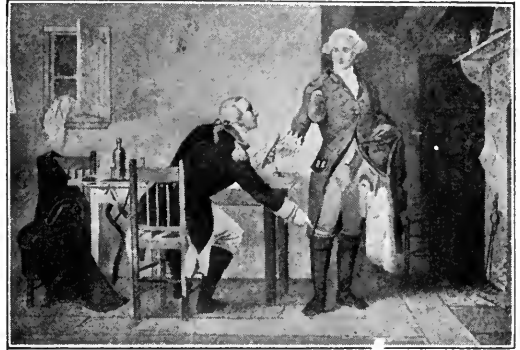

BENEDICT ARNOLD GIVING INFORMATION TO BRITISH OFFICER DURING REVOLUTIONARY WAR

See Definition of Treason.—Par. 1, Sec. 3.

Article IV. Relations of the States and Federal Government

SECTION 1.—Recognition of State Authority

Public Acts

Full faith and credit shall be given in each State to the public acts, records and judicial proceedings of every other State. And the

Congress may by general laws prescribe the manner in which such acts, records, and proceedings shall be proved, and the effect thereof.

SECTION 2.—Laws Regarding Citizens of the United States

Privileges and Immunities

1. The citizens of each State shall be entitled to all privileges and immunities of citizens in the several States.

Fugitives from Justice

2. A person charged in any State with treason, felony, or other crime, who shall flee from justice, and be found in another State, shall on demand of the executive authority² of the State from which he fled, be delivered up, to be removed to the State having jurisdiction of the crime.

²The Governor of the State.

Fugitive Slaves

3. No person³ held to service or labor in one State, under the laws thereof, escaping into another, shall, in consequence of any law or regulation therein, be discharged from such service or labor, but shall be delivered up on claim of the party to whom such service or labor may be due.

³“Person” here includes a slave. This provision is now superseded by the Thirteenth Amendment.



OFFICERS TAKING “A FUGITIVE FROM JUSTICE” BACK TO THE STATE WHERE HE COMMITTED THE CRIME

“A person charged in any State with treason, felony, or other crime, who shall flee from justice, and be found in another state, shall, . . . be delivered up. . . .”—Par. 2, Sec. 2.

SECTION 3.—New States and Territories



THE CAPITOL OF THE STATE OF ARIZONA
Arizona was the last State to be admitted to the Union (February 14, 1912) "New States . . . shall be admitted into this Union."—Par. 1, Sec. 3.

Admission of States

1. New States may be admitted by the Congress into this Union; but no new State shall be formed or erected within the jurisdiction of any other State; nor any State be formed by the junction of two or more States, or parts of State, without the consent of the Legislatures of the States concerned as well as of the Congress.

Territory and Property of the United States

2. The Congress shall have power to dispose of and make all needful rules and regulations respecting the territory or other property belonging to the United States; and nothing in this Constitution shall be so construed as to prejudice any claims of the United States, or of any particular State.

SECTION 4.—Protection Guaranteed by the Federal Government

Protection of the States

The United States shall guarantee to every State in this Union a republican form of government, and shall protect each of them

against invasion; and on application of the Legislature, or of the Executive (when the Legislature can not be convened), against domestic violence.

Article V. Power and Method of Amending the Constitution

Constitution: How Amended

The Congress, whenever two-thirds of both Houses shall deem it necessary, shall propose amendments to this Constitution, or, on the application of the Legislatures of two-thirds of the several States, shall call a convention for proposing amendments, which, in either case, shall be valid to all intents and purposes, as part of this Constitution, when ratified by the Legislatures of three-fourths of the several States, or by conventions in three-fourths thereof, as the one or the other mode of ratification may be proposed by the Congress; provided that no amendment which may be made prior to the year one thousand eight hundred and eight shall in any manner affect the first and fourth clauses in the ninth section of the first article; and that no State, without its consent, shall be deprived of its equal suffrage in the Senate.

AMENDING THE CONSTITUTION OF THE UNITED STATES

*The amendment authorizing the taxing of incomes was proposed to the Legislatures of the several states by the Sixty-first Congress in July, 1909, and was declared to have been ratified in a proclamation by the Secretary of State, February 25th, 1913.
An Amendment to the Constitution shall be valid to all intents and purposes when ratified by the legislatures of three-fourths of the several states.—Article 5.*

Article VI. General Provisions

Public Debt

1. All Debts contracted and Engagements entered into, before the adoption of this Constitution, shall be as valid against the United States under this Constitution, as under the Confederation.

Supremacy of Constitution

2. This Constitution, and the Laws of the United States which shall be made in Pursuance thereof; and all Treaties made, or which shall be made, under the Authority of the United States, shall be the supreme Law of the Land; and the Judges in every State shall be bound thereby, any Thing in the Constitution or Laws of any State to the Contrary notwithstanding.

Official Oath

3. The Senators and Representatives before mentioned, and the Members of the several State Legislatures, and all executive and judicial Officers, both of the United States and of the several States, shall be bound by Oath or Affirmation, to support this Constitution; but no Religious Test shall ever be required as a Qualification to any Office or public Trust under the United States.



REDUCED FAC-SIMILE FIRST PAGE OF THE CONSTITUTION

"This Constitution, . . . shall be the supreme Law of the Land."—Par. 2, Art. 6.



SECRETARY OF NAVY, EDWIN DENBY, TAKING OATH OF OFFICE

"All executive and judicial officers . . . shall be bound by Oath or Affirmation, to support this Constitution."—Par. 3, Art. 6.

Article VII. Ratification of Constitution

How Ratified

The ratification of the conventions of nine States shall be sufficient for the establishment of this Constitution between the States so ratifying the same.

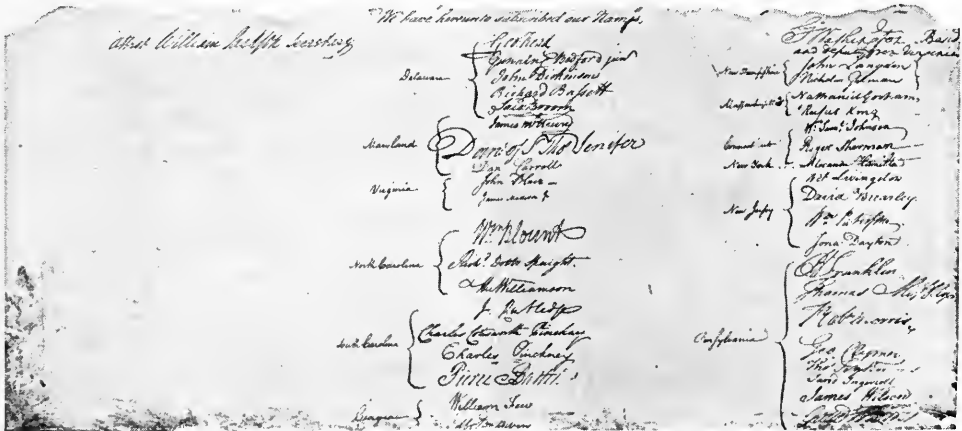

THE SIGNERS OF THE ORIGINAL CONSTITUTION

"Done in Convention by the Unanimous Consent of the States Present the Seventeenth Day of September in the Year of our Lord one thousand seven hundred and eighty-seven, and of the Independence of the United States of America the Twelfth."

Amendments to the Constitution

The following amendments to the Constitution, Articles I. to X., inclusive, were proposed at the First Session of the First Congress, begun and held at the City of New York, on Wednesday, March 4, 1789, and were adopted by the necessary number of States. The original proposal of the ten amendments was preceded by this preamble and resolution:

"The conventions of a number of the States having, at the time of their adopting the Constitution, expressed a desire, in order to prevent misconstruction or abuse of its powers, that further declaratory and restrictive clauses should be added, and as extending the ground of public confidence in the Government will best insure the beneficent ends of its institution;

"RESOLVED, By the Senate and House of Representatives of the United States of America, in congress assembled, two-thirds of both Houses concurring, that the following articles be proposed to the Legislatures of the several States, as amendments to the Constitution of the United States; all or any of which articles when ratified by three-fourths of the said Legislatures, to be valid to all intents and purposes, as part of the said Constitution, namely:"

(The Ten Amendments Declared in Force, December 15, 1791)



THE RIGHT OF FREE SPEECH

"Congress shall make no law . . . abridging the freedom of speech."—Article 1, Amendment.



"AN AMERICAN'S HOME, HIS CASTLE"
The right of the people to be secure in their persons, houses, papers, and effects, against unreasonable searches and seizures, shall not be violated.—Article 4, Amendment.

ARTICLE I

Religious Establishment Prohibited,
Freedom of Speech, of the Press,
and Right to Petition

Congress shall make no law respecting an establishment of religion, or prohibiting the free exercise thereof; or abridging the freedom of speech or of the press, or the right of the people peaceably to assemble, and to petition the Government for a redress of grievances.

ARTICLE II

Right to Keep and Bear Arms

A well-regulated militia being necessary to the security of a free State, the right of the people to keep and bear arms shall not be infringed.

ARTICLE III

No Soldier to be Quartered in Homes

No soldier shall, in time of peace, be quartered in any house without the consent of the owner, nor in time of war but in a manner to be prescribed by law.

ARTICLE IV

Right of Search and Seizure

The right of the people to be secure in their persons, houses, papers, and effects, against unreasonable searches and seizures, shall not be violated, and no warrants shall issue but upon probable cause, supported by oath or affirmation, and particularly describing the place to be searched, and the persons or things to be seized.

ARTICLE V

Provisions Concerning Prosecution,
Trial and Punishment. Private
Property Not to Be Taken
Unless, Etc.

No person shall be held to answer for a capital or other infamous crime unless on a presentment or indictment of a grand jury, except in cases arising in the land or naval forces, or in the militia, when in actual service, in time of war or public danger; nor shall any person be subject for the same offence to be twice put in jeopardy of life or limb; nor shall be compelled in any criminal case to be a witness against himself, nor be deprived of life, liberty, or property, without due process of law; nor shall private property be taken for public use, without just compensation.

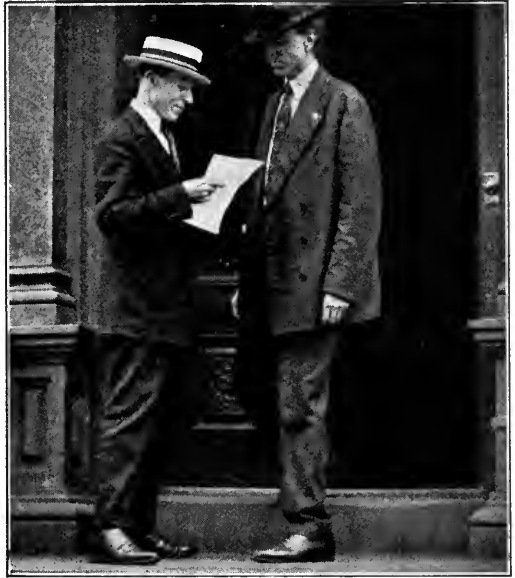

COURT AGENT SERVING WARRANT

" . . . Nor shall any person . . . be deprived of life, liberty, or property, without due process of law."—Article 5, Amendment.

ARTICLE VI

Right to Speedy Trial, Witness, Etc.

In all criminal prosecutions, the accused shall enjoy the right to a speedy and public trial, by an impartial jury of the State and district wherein the crime shall have been committed, which district shall have been previously ascertained by law, and to be informed of the nature and cause of the accusation; to be confronted with the witnesses against him; to have compulsory process for obtaining witnesses in his favor, and to have the assistance of counsel for his defence.

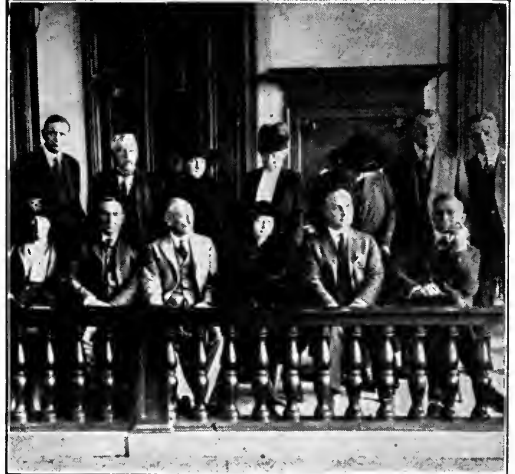

TRIAL BY JURY

"The right of trial by jury shall be preserved."—Article 7, Amendment.

ARTICLE VII

Right of Trial by Jury

In suits at common law, where the value in controversy shall exceed twenty dollars, the right of trial by jury shall be preserved, and no fact tried by a jury shall be otherwise re-examined in any court of the United States than according to the rules of the common law.

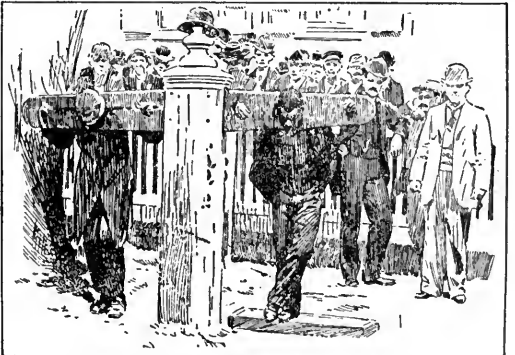

PRISONERS IN THE PILLORY

This form of punishment is discontinued. . . . "Nor cruel and unusual punishments inflicted."—Article 8, Amendment.

ARTICLE VIII

Excessive Bail or Fines and Cruel
Punishments Prohibited

Excessive bail shall not be required, nor excessive fines imposed, nor cruel and unusual punishments inflicted.

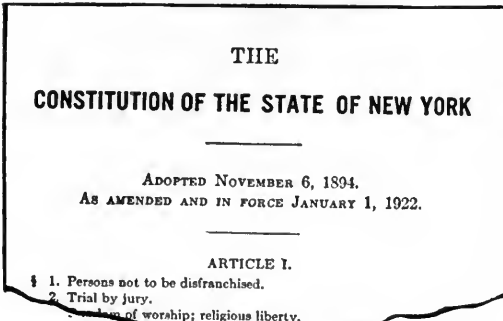

A STATE CONSTITUTION

Powers not given to the United States by the Constitution, nor prohibited to the States, are reserved to the States or to the people.—Article 10, Amendment.

ARTICLE IX

Rule of Construction of Constitution

The enumeration in the Constitution, of certain rights, shall not be construed to deny or disparage others retained by the people.

ARTICLE X

Rights of States Under Constitution

The powers not delegated to the United States by the Constitution, nor prohibited by it to the States, are reserved to the States respectively, or to the people.

Additional Amendments to the Constitution

The following amendment was proposed to the Legislatures of the several States by the Third Congress on the 5th day of March, 1794, and was declared to have been ratified in a message from the President to Congress, dated Jan. 8, 1798.

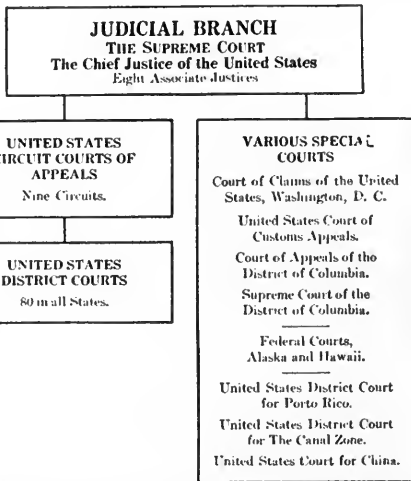

ARTICLE XI

Judicial Powers Construed

The judicial power of the United States shall not be construed to extend to any suit in law or equity, commenced or prosecuted against one of the United States, by citizens of another State, or by citizens or subjects of any foreign state.

CHART OF JUDICIAL BRANCH OF THE UNITED STATES GOVERNMENT,
Article 11, Amendment.

The following amendment was proposed to the Legislatures of the several States by the Eighth Congress on the 12th of December, 1803, and was declared to have been ratified in a proclamation by the Secretary of State, dated September 25, 1804.



PRESIDENTS OF THE UNITED STATES CHOSEN BY THE HOUSE OF REPRESENTATIVES

(1) Thomas Jefferson, (2) John Quincy Adams, (3) Rutherford Birchard Hayes. . . . In the first two cases the House of Representatives chose the President. In the latter case, a special committee decided the dispute over electors.—Article 12, Amendment.

ARTICLE XII

Choosing President and Vice-President

The electors shall meet in their respective States, and vote by ballot for President and Vice-President, one of whom at least shall not be an inhabitant of the same State with themselves; they shall name in their ballots the person voted for as President, and in distinct ballots the person voted for as Vice-President; and they shall make distinct lists of all persons voted for as President, and of all persons voted for as Vice-President, and of the number of votes for each, which list they shall sign and certify, and transmit, sealed, to the seat of the Government of the

United States, directed to the President of the Senate; the President of the Senate shall, in the presence of the Senate and House of Representatives, open all the certificates, and the votes shall then be counted; the person having the greatest number of votes for President shall be the President, if such number be a majority of the whole number of electors appointed; and if no person have such majority, then from the persons having the highest numbers, not exceeding three, on the list of those voted for as President, the House of Representatives shall choose immediately, by ballot, the President. But in choosing the President, the votes shall be taken by States, the representation from each State having one vote; a quorum for this purpose shall consist of a member or members from two-thirds of the States, and a majority of all the States shall be necessary to a choice. And if the House of Representatives shall not choose a President, whenever the right of choice shall devolve upon them, before the fourth day of March next following, then the Vice-President shall act as President, as in the case of the death or other constitutional disability of the President. The person having the greatest number of votes as Vice-President shall be the Vice-President, if such number be a majority of the whole number of electors appointed, and if no person have a majority, then from the two highest numbers on the list the Senate shall choose the Vice-President; a quorum for the purpose shall consist of two-thirds of the whole number of Senators, and a majority of the whole number shall be necessary to a choice. But no person constitutionally ineligible to the office of President shall be eligible to that of Vice-President of the United States.

The following amendment was proposed to the Legislatures of the several States by the Thirty-eighth Congress on the 1st of February, 1865, and was declared to have been ratified in a proclamation by the Secretary of State, dated December 13, 1865.

ARTICLE XIII
Slavery Abolished

1. Neither slavery nor involuntary servitude, except as a punishment for crime whereof the party shall have been duly convicted, shall exist within the United States, or any place subject to their jurisdiction.
2. Congress shall have power to enforce this article by appropriate legislation.

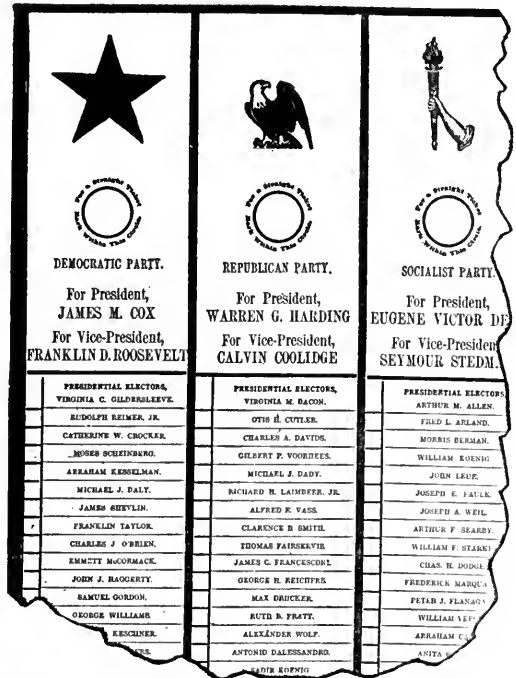

BALLOT OF CANDIDATES, ELECTORAL COLLEGE—1920

The members to the Electoral College are chosen by direct vote of the people.—Article 12, Amendment.



ABRAHAM LINCOLN—THE GREAT EMANCIPATOR



CHILDREN OF ALIENS, BORN IN AMERICA
"All persons born . . . in the United States, . . . are citizens of the United States."—Article 14, Paragraph 1, Amendment.



U. S. A. BONDS, A PUBLIC DEBT

"The validity of the public debt of the United States . . . shall not be questioned."—Article 14, Paragraph 4, Amendment.

The following, popularly known as the Reconstruction Amendment, was proposed to the Legislatures of the several States by the Thirty-ninth Congress on the 16th of June, 1866, and was declared to have been ratified in a proclamation by the Secretary of State, dated July 28, 1868. The amendment got the support of 23 Northern States; it was rejected by Delaware, Kentucky, Maryland, and 10 Southern States. California took no action. Subsequently it was ratified by the 10 Southern States.

ARTICLE XIV

Citizenship Rights Not to Be Abridged

1. All persons born or naturalized in the United States, and subject to the jurisdiction thereof, are citizens of the United States and of the State wherein they reside. No State shall make or enforce any law which shall abridge the privileges or immunities of citizens of the United States; nor shall any State deprive any person of life, liberty, or property without due process of law, nor deny to any person within its jurisdiction the equal protection of the laws.

2. Representatives shall be apportioned among the several States according to their respective numbers, counting the whole number of persons in each State, excluding Indians not taxed. But when the right to vote at any election for the choice of electors for President and Vice-President of the United States, Representatives in Congress, the executive and judicial officers of a State, or the members of the Legislature thereof, is denied to any of the male members of such State, being of twenty-one years of age, and citizens of the United States, or in any way abridged, except for participation in rebellion or other crime, the basis of representation therein shall be reduced in the proportion which the number of such male citizens shall bear to the whole number of male citizens twenty-one years of age in such State.

3. No person shall be a Senator or Representative in Congress, or elector of President and Vice-President, or holding any office, civil or military, under the United States, or under any State, who, having previously taken an oath, as a member of Congress, or as an officer of the United States, or as a member of any State Legislature, or as an executive or judicial officer of any State, to support the Constitution of the United States, shall have engaged in insurrection or rebellion against the same, or given aid and comfort to the enemies thereof. But Congress may, by a vote of two-thirds of each House, remove such disability.

4. The validity of the public debt of the United States, authorized by law, including debts incurred for payment of pensions and bounties for services in suppressing insurrection and rebellion, shall not be questioned. But neither the United States nor any State shall assume or pay any debt or obligation incurred in aid of insurrection or rebellion against the United States, or any claim for the loss or emancipation of any slave; but all such debts, obligations, and claims shall be held illegal and void.

5. The Congress shall have power to enforce by appropriate legislation the provisions of this article.

The following amendment was proposed to the Legislatures of the several States by the Fortieth Congress on the 27th of February, 1869, and was declared to have been ratified in a proclamation by the Secretary of State, dated March 30, 1870. It was not acted on by Tennessee; it was rejected by California, Delaware, Kentucky, Maryland, and Oregon; ratified by the remaining 30 States. New York rescinded its ratification January 5, 1870. New Jersey rejected it in 1870, but ratified it in 1871.

ARTICLE XV

Equal Rights for Citizens

1. The right of the citizens of the United States to vote shall not be denied or abridged by the United States or by any State on account of race, color, or previous condition of servitude.

2. The Congress shall have power to enforce the provisions of this article by appropriate legislation.

The following amendment was proposed to the Legislatures of the several States by the Sixty-first Congress on the 12th day of July, 1909, and was declared to have been ratified in a proclamation by the Secretary of State, dated February 25, 1913. The income tax amendment was ratified by all the States except Connecticut, Florida, Pennsylvania, Rhode Island, Utah, and Virginia.

ARTICLE XVI

Income Taxes Authorized

The Congress shall have power to lay and collect taxes on incomes, from whatever sources derived, without apportionment among the several States, and without regard to any census or enumeration.

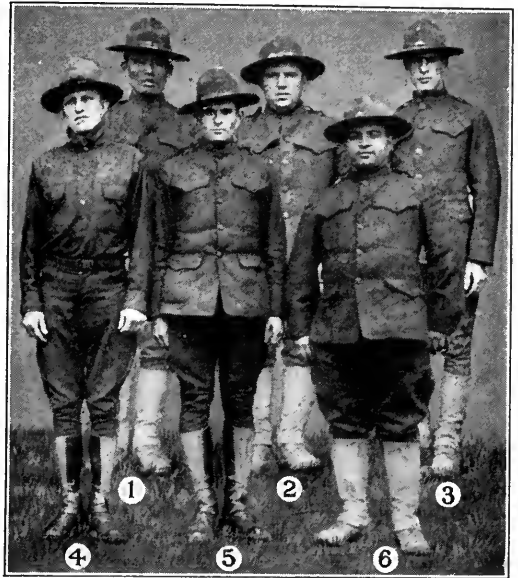

SIX DIFFERENT RACES SHOWN HERE

These American soldiers, who fought in the Great World War, represent the following races: (1) Chinese, (2) Italian, (3) Greek, (4) American, (5) Russian, and (6) Turkish.

"The right of a citizen of the United States to vote shall not be denied or abridged . . . on account of race." Article 15, Amendment.



WOMAN ENTERING VOTING BOOTH

The Nineteenth Amendment added the word "sex" to the Fifteenth Amendment.



PAYING INCOME TAX

"Congress shall have power to lay and collect taxes on incomes."—Article 16, Amendment.



FORMER SECRETARY OF STATE BRYAN
SIGNING 17TH AMENDMENT TO THE
CONSTITUTION, MAY 31, 1913

"The Senate of the United States shall be composed of two senators from each state, elected by the people."—Article 17, Amendment.



FEDERAL OFFICERS ENFORCING THE
EIGHTEENTH AMENDMENT

"The manufacture, sale, or transportation of intoxicating liquors . . . is hereby prohibited."—Article 18, Amendment.

The following amendment was proposed to the Legislatures of the several States by the Sixty-second Congress on the 16th day of May, 1912, and was declared to have been ratified in a proclamation by the Secretary of State, dated May 31, 1913. It got the vote of all the States except Alabama, Delaware, Florida, Georgia, Kentucky, Louisiana, Maryland, Mississippi, Rhode Island, South Carolina, Utah, and Virginia.

ARTICLE XVII

Election of United States Senators

1. The Senate of the United States shall be composed of two Senators from each State, elected by the people thereof, for six years; and each Senator shall have one vote. The electors in each State shall have the qualifications requisite for electors of the most numerous branch of the State Legislatures.

2. When vacancies happen in the representation of any State in the Senate, the executive authority of such State shall issue writs of election to fill such vacancies; Provided, That the Legislature of any State may empower the Executive thereof to make temporary appointment until the people fill the vacancies by election as the Legislature may direct.

3. This amendment shall not be so construed as to affect the election or term of any Senator chosen before it becomes valid as part of the Constitution.

The following amendment was proposed to the Legislatures of the several States by the Sixty-fifth Congress, Dec. 18, 1917; and on Jan. 29, 1919, the United States Secretary of State proclaimed its adoption by 36 States, and declared it in effect on Jan. 16, 1920.

Early in 1920, the validity of the Eighteenth Amendment was upheld by the Supreme Court of the United States, in suits to void, brought by the States of Rhode Island and New Jersey, and by various brewers and distillers.

ARTICLE XVIII

Liquor Prohibition Amendment

1. After one year from the ratification of this article the manufacture, sale, or transportation of intoxicating liquors within, the importation thereof into, or the exportation thereof from the United States and all territory subject to the jurisdiction thereof, for beverage purposes is hereby prohibited.

2. The Congress and the several States shall have concurrent power to enforce this article by appropriate legislation.

3. This article shall be inoperative unless it shall have been ratified as an amendment to

the Constitution by the Legislatures of the several States; as provided in the Constitution, within seven years from the date of the submission hereof to the States by the Congress.

The following amendment was proposed to the Legislatures of the several States by the Sixty-fifth Congress, having been adopted by the House of Representatives, May 21, 1919, and by the Senate, June 4, 1919. On Aug. 26, 1920, the United States Secretary of State proclaimed it in effect, having been adopted (June 10, 1919-Aug. 18, 1920), by three-quarters of the States. The Tennessee House, Aug. 31, rescinded its ratification 47 to 24.

ARTICLE XIX

Nation-Wide Suffrage to Women

1. The right of citizens of the United States to vote shall not be denied or abridged by the United States or by any State on account of sex.

2. Congress shall have power, by appropriate legislation, to enforce the provisions of this Article.



WOMEN'S SUFFRAGE DEMONSTRATION

*"The right of citizens of the United States to vote shall not be denied or abridged . . . on account of sex."
—Article 19, Amendment.*



THE GREAT SEAL OF THE UNITED STATES OF AMERICA



©The American Viewpoint Society

Drawing by Hanson Booth

AMERICAN CITIZENS OF THE FUTURE

Citizenship is the highest and greatest gift of the nation

American Citizenship

Intelligence, Self Control, and Conscience—the Three Qualities Most Needed in the Citizens of a Democracy

OVER 34,000,000 IMMIGRANTS have entered the United States since 1820. At the present time, according to the 1920 census, there are 13,712,754 foreign born in America, including immigrants from more than two score nations. Under these circumstances, who are American citizens and how may one become an American citizen, are vital questions that touch us all, native and alien born alike.

The Greatest Gift

Citizenship is the highest and greatest gift of the nation. When conferred on an individual who comes from another land, it makes of him or her a part of our great society, and clothes such an individual with the rights and privileges of a native American citizen.

This gift, from the Federal Government, itself, naturally and rightly, is given only to those aliens who will fit in with the American civilization. To those who give evidence of sound moral and political character; to those who are willing to take the trouble of showing, through study of the Constitution, the American Government, and the English language, their appreciation of, and their ability to use with judgment *this great gift of citizenship*—to all those, this gift is freely, gladly, and wholeheartedly given.

Naturalization

Naturally, the people of the United States fall into two classes, *citizens* and *aliens*. The Government has provided a means whereby men and women from other countries—*aliens*—may become citizens of the United States. This method of becoming a citizen is called *naturalization*. It is the act of adopting

foreigners and clothing them with American citizenship. There are *three* ways through which an alien may become a naturalized citizen of the United States.

The First Way

In the first place, the National Government may confer citizenship upon certain people *en masse*, collectively, or upon particular classes of persons. Such naturalization may come to individuals as the result of *conquest*, by

treaty, by *special act of congress*, or when new states are admitted to the Union.

For example: The citizens of the former independent state of Texas became citizens of the United States *when Texas was admitted to the Union*. In 1917, the people of Porto Rico, as a body, became full citizens of the United States *by act of Congress*. When Louisiana, Florida, and Alaska were bought from France, Spain, and Russia respectively, the people living in those

Four Steps

THERE are four steps which an alien must take to become an American citizen: First, he must file a Declaration of Intention; second, a Certificate of Arrival; third, a Petition for Naturalization; fourth, he must appear before a judge, submit to an examination, and declare on oath his allegiance to America.

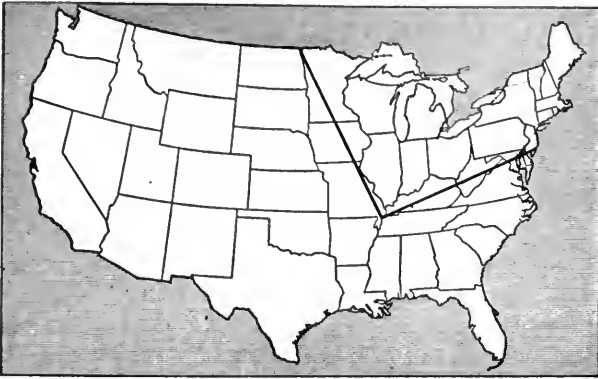

Over 34,000,000 aliens have come to this country since 1820. At present there are almost 14,000,000 foreign born in the United States. Nearly 10,000,000 live in 18 PER CENT OF THE TERRITORY OF THE UNITED STATES,—that part enclosed by the heavy lines drawn on the map. In this section are most

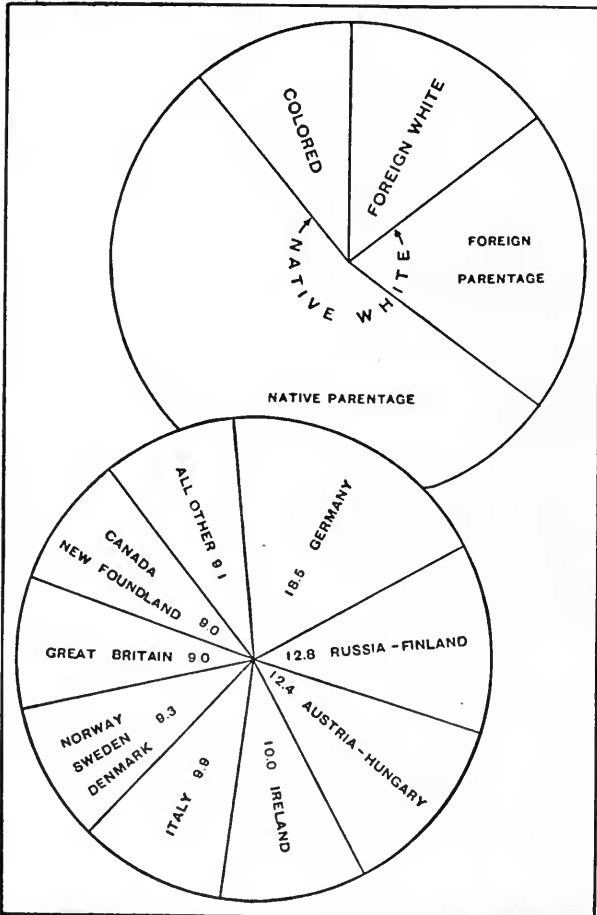

of our great cities. THE TOP CIRCLE is interesting for it shows the proportion of foreign born and those of foreign born parentage to the native white population of this country. THE SECOND CIRCLE shows the percentage of each of the more important alien races that go to make up this huge total of 13,712,754 foreign born in the United States today.

regions later became citizens of the United States in this collective manner.

The Second Way

Citizenship, in the second place, may be acquired through the naturalization, or through the American citizenship of *someone else*. Minor children, for example, may become citizens through the *naturalization of their father*. A citizen of the United States, however, cannot give American citizenship *by adoption* to a child of foreign born nationality.

Citizenship of Women

Formerly, the wife of a foreigner automatically became a citizen of this country when her husband was naturalized. On the other hand, an American woman who married a foreigner automatically lost her American citizenship. A new law changes this, and provides "*that the right of any woman to become a naturalized citizen of the United States shall not be denied or abridged because of her sex, or because she is a married woman.*"

Now, a woman who marries a citizen of the United States or whose husband becomes naturalized does not automatically become a citizen. She, herself, must be naturalized. In doing so, however, she does not have to file a *Declaration of Intention* and is only required to have lived continuously in the United States, Hawaii, Alaska, or Porto Rico for one year, at least, preceding the filing of her petition. A woman citizen of the United States who marries a foreigner (except one ineligible to American Citizenship) does not lose

her American Citizenship unless she in court formally renounces it. A woman who before the passage of this new law had lost her United States Citizenship by reason of a marriage to a foreigner, may regain this citizenship by naturalization.

The Third Way

Unless *naturalized* in one of these two ways, an alien must go through the third method of naturalization—the *formal process of taking out citizenship papers*. The right to do this is not granted to all foreign born people. According to the naturalization laws, only those aliens who are white or who are of African nativity or of African descent, are eligible for American citizenship.

Since the Chinese and Japanese, and members of other yellow or brown races, are not considered white persons or persons of the African race, they are excluded from becoming citizens of the United States.

Those who can neither speak nor understand English cannot become citizens of the United States by naturalization. Neither can *polygamists*, and *criminals*, such as murderers, thieves, bribers and perjurers, or persons of immoral character become naturalized. Individuals not believing in, or opposed to organized government, or members of or affiliated with any group or association of persons teaching such doctrines, are also barred from this great privilege of American citizenship.

Four Necessary Steps

There are *four* necessary steps which must be taken by an alien



Since about one-eighth of our total population of 105,710,620 is of alien birth, the subject of American citizenship is of great importance. There are those who cannot become citizens of the United States. Illiterates, polygamists, **CRIMINALS**, and those opposed to organized government, cannot become citi-



zens. Only those who are of good character, and who are **WHITE PERSONS**, or, who are of **AFRICAN NATIVITY** or of African descent can become citizens.

Form 201B

FACTS FOR DECLARATION OF INTENTION

U. S. DEPARTMENT OF LABOR
NATURALIZATION SERVICE

NOTE.—A copy of this form will be furnished by the clerk of the court, the Chief Naturalization Examiner, or the public-school teacher to each applicant for a declaration of intention, so that he can at his leisure fill in the answers to the questions. After being filled out the form is to be returned to the clerk. It is to be used by him in properly filling out the declaration. If the applicant handed out after June 29, 1906, his declaration should not be filed until the name of the vessel to definitely give (or the name of the railroad and border port in the United States through which the alien entered), as well as the date of arrival.

TO THE APPLICANT.—The fee of one dollar required by law for the declaration, must be paid to the clerk of the court before he commences to fill out the declaration of intention. No fee is chargeable for this blank, and none should be paid for assistance in filling it out, as the Naturalization Examiner of the public-school teacher will help you free of charge.

My name is _____ Age: _____ years.
(Name should appear here in true original, and correct name in English. (Give age last birthday.)

_____ known as _____
(If name has been any other name in this country, that name should be shown on last immediately above.)

Complexion: _____

Form 2020

U. S. DEPARTMENT OF LABOR
NATURALIZATION SERVICE

TRIPLE DATE
It is the applicant's duty to make the date

No. _____

UNITED STATES OF AMERICA

DECLARATION OF INTENTION

Invalid for all purposes seven years after the date hereof

_____ ss: In the _____ Court
of _____

%, _____ aged _____
do declare on _____
complexion _____

The first step that an alien who desires to become a citizen must take is to file a Declaration of Intention. Before he files such a Declaration he should secure a paper called **FACTS FOR DECLARATION OF INTENTION**, and if he cannot do so himself, he should get someone to assist him to fill it out prop-



erly. Then, **WHEN HE GOES TO THE CLERK OF THE COURT'S OFFICE**, he will know how to fill out properly the Declaration of Intention. The alien

Form 2020

REQUEST FOR CERTIFICATE OF ARRIVAL
FOR USE OF ALIENS ARRIVING AFTER JUNE 29, 1906

U. S. DEPARTMENT OF LABOR
NATURALIZATION SERVICE

Know to the Clerk of the Court:

This form is to be used only when an alien arrived in this country after June 29, 1906.

When an alien desires to petition for naturalization, this form should be given to him before he is permitted to file his petition, and the execution of the petition for naturalization should not be commenced until this certificate of arrival is received by the clerk of the court. The alien should be directed to complete the letter below and carefully fill in all the blanks in this form, as the information is necessary to obtain the certificate of arrival, and will aid the clerk of the court in filing the petition for naturalization. The alien should then mail this form to the Commissioner of Naturalization, Department of Labor, Washington, D. C.

That official will at once take steps to obtain and forward to the clerk of court the certificate of arrival required by section 4 of the act of June 29, 1906, to be attached to and made a part of the petition at the time of its filing. The statement of facts will also be forwarded to the clerk of the court. Notice will also be given to the alien that the certificate has been sent to the clerk of the court named by him.

COMMISSIONER OF NATURALIZATION,
U. S. DEPARTMENT OF LABOR,
WASHINGTON, D. C.

See: I came to this country after June 29, 1906. Please obtain a certificate showing my arrival in the United States and forward it to the Clerk of the _____

(The person who has filled this form will be asked to sign the petition for naturalization which I have filed.)

must, in the second place, secure a **CERTIFICATE OF ARRIVAL**, that is, if he came to this country before 1906. To secure this certificate, he must make a request for it to the Bureau of Naturalization.

man or woman who desires to become an American citizen. *First*, a paper called a *Declaration of Intention* must be filed. *Second*, a *Certificate of Arrival* must be secured. *Third*, a second paper called a *Petition for Naturalization* must be filled out and filed. *Fourth*, the applicant must appear before a *judge*, submit to an examination regarding his *knowledge of the Constitution and his loyalty to the American Government*, and *declare on oath in open court that he will support the Constitution of the United States and renounce all allegiance to any other country.*

The entire cost is but \$5.00; \$1.00 when the First Paper (the Declaration of Intention) is filed and the remaining \$4.00 when the Petition for Naturalization is filed with the Clerk of Court.

The Declaration of Intention

The *first step* that an alien desiring to become a citizen must take is to declare his purpose of becoming one by filing a *Declaration of Intention* to reside permanently in the United States and within seven years to renounce all allegiance to his former country and to its ruler.

Any alien, man or woman, *eligible to citizenship*, and over eighteen years of age, may file such a declaration at the *office of the Clerk of Court*. In order to do so, witnesses need not be brought, nor is it necessary for the alien to be able to speak English at the time. In fact, he does not have to be able even to sign his name; his mark will do. This declaration is usually called "*The First Papers.*"

The Certificate of Arrival

All aliens who came to the United States after June 29th, 1906, must secure a *Certificate of Arrival*. This is the *second step*. Those who came before this time do not require such a certificate. The application has spaces to show the time, the place, and the manner of arrival in the United States and may be secured free of charge from the *Clerk of Court*, or, from some agency in the community in which the alien lives which is interested in naturalization. After this request for a *Certificate of Arrival* is made out, it must be sent to the *Bureau of Naturalization*, Washington, D. C., and returned with the *Certificate of Arrival* to the *Clerk of the Court* to whom the alien has applied for citizenship. The applicant is then notified that his *Certificate of Arrival* has been received and is instructed to proceed at once with the third step.

U. S. DEPARTMENT OF LABOR
BUREAU OF NATURALIZATION

NOTE—FOR USE OF ALIENS WHO ARRIVED BEFORE JUNE 29, 1906.

FACTS FOR PETITION FOR NATURALIZATION

Clerk of court and applicant should read these instructions carefully. Clerk of court should refer to exact petition for alien as he refers to the Court after June 29, 1906, until certificate of arrival is furnished by the Bureau of Naturalization, after receipt of the alien on June 29. (There is but one Blue Form.) A copy of this form (21) should be furnished by the clerk of court for each applicant for a petition for naturalization who arrives in this country on or before June 29, 1906, and the first of such copies filed in the papers in the court.

The clerk of the court must enter) the fee of \$4 below by endorsement to fill out the petition as far as possible before June 29, 1906, so that the first of such copies filed in the papers in the court.

After being filed out, this form is to be taken by the applicant to the clerk, to be used by him in properly filling out the petition.

Witnesses must be citizens of the United States. If any witness is a naturalized citizen, he must take his certificate of naturalization, encased in a separate paper, to the court when the petition is filed, and when it is heard by the court.

My name is _____
 (Last name first, then first, middle, and last name in full)

I am _____
 (If not naturalized citizen of the United States, give name of the country of which you are a citizen)

I was born _____
 (State or your name)

U. S. DEPARTMENT OF LABOR
BUREAU OF NATURALIZATION

UNITED STATES OF AMERICA

PETITION FOR NATURALIZATION

For the District of _____ Court of _____

The petitioner is _____

My place of residence is _____

My name is _____

AFFIDAVITS OF PETITIONER AND WITNESSES

I, the undersigned, being duly sworn, depose and say that he is the petitioner in the above-entitled proceeding; that he has read the foregoing petition and knows the contents thereof; that the said petition is signed with his full true name; and that to the best of his own knowledge, belief and true information, and to those matters he believes it to be true.

Witness my hand and seal of office this _____ day of _____ 19____

_____ reading at _____

_____ reading at _____

Witness and say that he is a citizen of the United States of America.

If the records show that the applicant is eligible for citizenship in so far as the facts bearing upon his arrival to this country are concerned, the Bureau of Naturalization will send the *Certificate* to the

Petition for Naturalization

The *third step* is the filing of a *Petition for Naturalization*, commonly called "*Application for Second Papers*." This important step is called a *petition* because the individual is requesting the United States of America to make him one of its citizens.

This *Application for Second Papers* must be made out at least two years after and not more than seven years after the alien's Declaration of Intention. If he waits more than seven years he must make out a new Declaration or "*First Paper*" before making application for his second papers as his original Declaration of Intention is of no value.



Clerk of the Court to whom the alien has applied for citizenship. Then the alien takes the third step, the filing of a **PETITION FOR NATURALIZATION**. In



filing this petition, the petitioner, whether man or woman, must take **TWO WITNESSES** to the court.



Within ninety days after the filing of the Petition for Naturalization, the petitioner and his witnesses will be examined by a NATURALIZATION EXAMINER. After the ninety days, if this preliminary ex-



amination has proven satisfactory, the alien and his witnesses will be examined a second time, but this time IN OPEN COURT BEFORE THE JUDGE. If the



Court is satisfied that the applicant has met all the requirements of the naturalization law, then the alien will be asked to take the OATH OF ALLEGIANCE.

Two Witnesses

Every alien, in order to make the petition (Petition for Naturalization), must have resided in the United States *at least five consecutive years*, and *at least one year* in the State in which the petition is made. He must appear at the office of the *Clerk of the Court* to file his petition. Two citizens of the United States who have personally known him for *five years* in the United States, the last of which must be in the State in which he makes his petition, *must come with him as witnesses*, and be willing to testify to his good and law abiding character and to his respect and love for America and American ideals and institutions.

If the alien has not lived for five years in the state he may bring two witnesses who have known him all of the time he has lived in the State, and secure *written statements from two other citizens* who knew him while he lived in any other state. The petitioner must also take with him his *first papers* (the Declaration of Intention), and his notice from the Bureau of Naturalization that his Certificate of Arrival has been sent to the Court.

The Examination

Not less than *ninety days* after the filing of this petition (Petition for Naturalization), the applicant must take the *fourth and last step* in becoming an American citizen. Now he must appear in *open court*. During the ninety days and before taking this final step, the Federal Government, through its *naturalization examiners*, conducts a thorough investigation of the

statements made by the petitioner and his witnesses. A *naturalization examiner* will question the alien regarding his knowledge of the Government and history of the United States, also about the government of the state and city in which he lives.

Final Papers

The petitioner, after appearing before the examiners, then presents himself in open court. He is examined again by the *Judge* and if found acceptable, is allowed to take the *Oath of Allegiance* to the United States. After taking the oath, the new citizen is given a *Certificate of Naturalization* usually called "Second Papers," which shows him to be an American citizen.

The Oath of Allegiance

The oath which the petitioner takes is:

"I HEREBY DECLARE ON OATH, THAT I ABSOLUTELY AND ENTIRELY RENOUNCE AND ABJURE ALL ALLEGIANCE AND FIDELITY TO ANY FOREIGN PRINCE, POTENTATE, STATE OR SOVEREIGNTY, AND PARTICULARLY TO (NAME OF SOVEREIGN OF COUNTRY), OF WHOM I HAVE HERETOFORE BEEN A SUBJECT; THAT I WILL SUPPORT AND DEFEND THE CONSTITUTION AND LAWS OF THE UNITED STATES OF AMERICA AGAINST ALL ENEMIES, FOREIGN AND DOMESTIC, AND THAT I WILL BEAR TRUE FAITH AND ALLEGIANCE TO THE SAME."



A woman who is applying for citizenship must take the same steps as a man. She, too, with her two witnesses, must PASS A PRELIMINARY EXAMINATION. She too, with her two witnesses, MUST



APPEAR IN OPEN COURT and satisfy the Judge as to her knowledge of the American Government and the Constitution and the government of the state



and city in which she lives. After which, if the Court is satisfied, she MUST TAKE THE OATH OF ALLEGIANCE.



After the oath of allegiance has been administered, the newly naturalized citizen IS HANDED A CERTIFICATE OF NATURALIZATION which certifies



that the holder has met all the requirements of the law and is entitled to enjoy all the civil and political rights that a native born American citizen enjoys.



This is a reduced fac-simile of a CERTIFICATE OF NATURALIZATION which every citizen receives upon becoming a naturalized citizen of the United States. The holder of such a certificate should carefully preserve it, as there are times when he may be asked to produce it.

Comply With Law

It is to the interest of an alien desiring citizenship that he comply to the fullest extent with the plain requirements of the naturalization law before filing his petition. Courts may cancel certificates of naturalization when received through fraud, or even under misunderstanding or misinterpretation of the law.

False statements on the part of an alien desiring citizenship, or on the part of his witnesses, are felonies under the Federal Statutes and are severely punished by fine and imprisonment.

Citizenship Classes

In many parts of the United States, citizenship classes have been organized to meet the needs of aliens taking out their naturalization papers, and these classes should be used by the declarants, and petitioners and their wives wherever possible. The Bureau of Naturalization at Washington is also ready to assist aliens to solve their difficulties in becoming American citizens.

Many fall by the wayside before completing all the necessary steps. During the years from 1907 to 1922, over 3,700,000 Declarations of Intention were filed. Only 1,885,620, or about one-half, made petitions for their second papers during the same time, and of these, only 1,608,437 secured their final Certificates of Citizenship.

Soldiers and Sailors

Honorably discharged soldiers and sailors of foreign birth who served during the World War are exempt from some of these naturalization steps. A veteran

may take his discharge from our army or navy to a naturalization examiner, be identified by two American citizens, and then file his petition for naturalization in the naturalization court most convenient to him. That court will hear his petition immediately, and he can secure, without further trouble, his naturalization certificate as an American citizen.

The Bureau of Naturalization at Washington is ready to advise any foreign born American soldier or sailor regarding his citizenship status.

Citizenship Difficulties

Naturalized citizens, and children of naturalized aliens—sometimes even the children born in this country of foreign parents, often are faced with serious and confusing citizenship difficulties when they leave this country. One difficulty arises over the fact that some countries—most European and Latin-American countries—*claim as their citizens all children born abroad of their own nationals.*

Uncle Sam, on the other hand, while making the same claim, also claims as citizens *all children born on American soil* no matter what the nationality of their parents may be, and regardless of race, sex or color. He even regards as Americans the children born here of Chinese and Japanese parents even though he does not allow their parents to become naturalized.

Naturally, misunderstandings arise, especially when people return to the old country.

Generally such difficulties are settled in a mutually friendly



Soldiers and sailors of foreign birth who served during the World War, can acquire citizenship more easily than civilian aliens. A veteran may take his discharge paper to a Naturalization Examiner, be identified by two American citizens, and then **FILE HIS PETITION FOR NATURALIZATION.** He will



be heard immediately **IN ANY NATURALIZATION COURT** in the district in which he lives, and can



secure, without further trouble, his naturalization certificate as an American citizen.

Note: The photographs illustrating the steps taken in the process of naturalization, and run on this and the preceding pages of this chapter, were made exclusively for this book by authority of James J. Davis, Secretary of Labor, and under the direction of Raymond F. Crist and O. T. Moore of the Bureau of Naturalization.



Every citizen should know, obey, and support the law. The symbol of the law of our country is the flag. Everyone should observe these simple rules which are called "Courtesy to the Flag." The flag should never be left outside after sundown. It should always **BE HUNG FREE**, that is, it should never be tied or tacked to anything. When the flag passes by,



during a parade, for example, **ALL MALE CITIZENS SHOULD SALUTE IT** as Theodore Roosevelt and the late Mayor Mitchel of New York City are seen saluting it. If the citizen is in uniform he must salute as the officers in the picture are saluting.

manner, but in times of war nations are apt to claim as citizens, everyone they possibly can, especially young men. People who come under this double citizenship rule—who have two citizenships—may find it troublesome if they go back to the old country during such times. *One should be sure of his citizenship before traveling in war time.*

Citizenship Endangered

Naturalized citizens who leave the United States must also be careful about the length of time *they remain away*. Naturalization is a privilege and may be revoked.

If within five years after securing citizenship papers an individual returns to his native country, and lives there for *two years*, or if he goes to another country and stays away from this country for *five years*, his naturalization may be *canceled* by our Government.

The Federal authorities assume that such an individual does not desire to remain an American citizen. *Diplomatic and Consular officers* of the United States are obliged to give to the *Department of Justice* the name of such a person.

In order to prevent such loss of citizenship, a naturalized citizen must report to the *American Embassy* or to an *American Consular Office* in the foreign country where he is living and present satisfactory evidence of his intention to remain a citizen of the United States. If this is not done, a naturalized citizen may find that he has lost his American citizenship and may also, on account of the *new percentage*

immigration laws, find it most difficult to return to this country.

Children Born Abroad

Children born abroad of American parents likewise have serious difficulties at times. The United States considers a *child born on foreign soil* an American citizen if its father was an American citizen when the child was born, and provided the father, at any time, had resided in the United States.

The United States, however, will only give protection to such a child, if, at the age of *eighteen*, he records his intention at an *American Consulate* of becoming a resident and remaining a citizen of the United States; and on reaching the age of *twenty-one* takes the *oath of allegiance* to the United States.

This American protection will not be given in all cases. Suppose such a child born in France of American parents, reaches the military age. A war breaks out. He is taken by the French authorities for military service. The young man appeals to the United States for assistance. He will find that the United States will not recognize his appeal and will not step in to protect him, but, on the contrary, will say: *You were born in France, you have lived in France, you are under obligations to France; do your duty!*

This is only fair on our part. We have millions of people born in this country of foreign parents who, under our laws, are considered American citizens and who are liable to military duty in case of war. If such individuals claimed the citizenship of another country when war



In taking down the flag, as Mrs. Harding, wife of the President of the United States is doing, great care must be taken TO PREVENT ANY PART OF THE FLAG FROM TOUCHING THE GROUND. Betsy

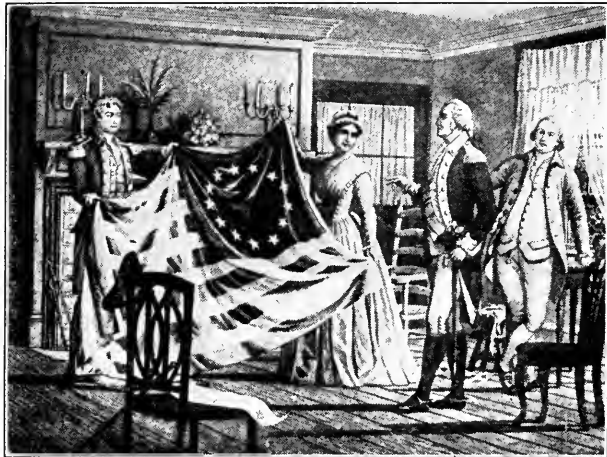

Ross, daughter of an American patriot, is said to have designed the first flag of our country. THE STARS IN THIS FLAG REPRESENT THE THIRTEEN ORIGINAL STATES. Today there are forty-eight stars in the flag, a star for each state. If Alaska, for example, becomes a state of the Union, another star will be added to the flag. The number of stripes in the flag never change.



Naturalized citizens who hold or recently have held public office in the United States may be numbered by the thousands. Space permits the naming of but a few:

1. James J. Davis, present SECRETARY OF LABOR, born in Wales. 2. Franklin Knight Lane, SECRETARY OF THE INTERIOR under President Wilson, born in Canada. 3. William Bauchop Wilson, SECRETARY OF LABOR under President Wilson, born in Scotland. 4. Knute Nelson, SENATOR from Minnesota, born in Norway. 5. William Spry, GOVERNOR of Utah, born in England. 6. Julius Kahn, CONGRESSMAN from California, born in Bavaria. 7. Oscar Solomon Strauss, AMBASSADOR to Turkey, born in Bavaria. 8. Jacob Gould Schurman, U. S. MINISTER to Greece and China, born in Canada. 9. Henry Morgenthau, AMBASSADOR to Turkey, born in Germany. 10. John W. Goff, JUDGE OF THE SUPREME COURT OF NEW YORK, born in Ireland. 11. Jacob Riis, MEMBER OF PARKS AND PLAYGROUNDS COMMISSION, New York, born in Denmark. 12. James Couzens, MAYOR of Detroit, born in Canada.

broke out, in order to evade military service in the United States, Uncle Sam would say to them: *You were born in America, you are living in America, you are under obligations to America; do your duty by America!*

Rights and Privileges

When an alien has become a citizen of the United States of America, what are his rights and privileges? With one exception, he shares all the benefits which belong to a native born citizen. He can hold any political office, except that of *President* or *Vice President* of the United States, privileges that are reserved to the native born.

All other political and civil privileges are his. Politically, a naturalized citizen has the *right to share in the government through his vote* and may hold *any civil service office*. He is entitled to American protection at home and abroad.

Constitutional Rights

At home an American citizen is constitutionally guarded in certain fundamental rights. He has the right *to free speech, to assemble, to make a petition, to fair treatment if accused of a crime, to personal liberty, to control property, and to religious freedom.*

Rights and Their Use

Often, however, there is much confusion of thought over these constitutional rights. A student, many years ago, asked his schoolmaster where his rights began and where they ended. The reply is worth repeating. "*Your rights,*" said the old teacher, "*end just where the other fel-*

low's rights begin." There is a truth in this reply that many people in America need to learn.

Every right must be used within reason, with due regard to the rights of others, and one may even add, to the rights of the society in which one lives. *The right to assemble and to free speech* does not mean permission to hold a meeting and address an audience in the middle of a busy street, thus blocking traffic. Free speech does not carry with it the right to slander another's reputation. Free speech does not include the right to advocate the overthrow of the government by riots and violence.

If the individual use of a right endangers the health, or the morals, the peace or the safety of others, that right may become *license*, and may be curbed. In other words, *the full enjoyment of rights in a democracy calls for a great deal of common sense and self control on the part of the individuals claiming them.*

The Citizen's Obligations

Every right has a corresponding obligation. Duty should be stressed as strictly as rights in a democracy, or democracy will fail. What are some of the duties which all Americans should practice?

Is it too much to ask that a citizen know his country's history and be proud of it? Every citizen should *know, obey and support* the law. If he thinks a law unjust or unwise, he should attempt to change it in a constitutional manner.

Every believer in good government should register and vote, cooperate with other citizens in the public welfare and honor and respect the National Flag.

The citizen also should share in the common burdens of his country. No one has the right to share in the *common privileges* and then to shirk the *common burdens*, such as those of *paying taxes and guarding against crime*. War is another common burden. Only a *slacker* accepts the privileges and the rights afforded by America and then refuses to fight or die in the nation's cause, if need be, when trouble comes.

The Qualities of a Good Citizen

Intelligence, self control, and conscience, are the three qualities which, according to a great political writer, are most needed in the citizens of a democracy. A citizen must be able to understand the interests and the problems of this great nation.

A citizen must be able and willing to subordinate his own will to the general will. A citizen must feel his responsibility and be prepared to make his country a better place to live in by helping, by learning, and by giving service.

The United States has many great and difficult problems to solve. Some even claim that democracy is on trial. America, however, will face the future without fear if it can build upon citizens with these qualities—*intelligence, self control and conscience!*

PLEDGE OF ALLEGIANCE

"I PLEDGE ALLEGIANCE TO MY FLAG AND TO THE REPUBLIC FOR WHICH IT STANDS; ONE NATION INDIVISIBLE, WITH LIBERTY AND JUSTICE FOR ALL."



©The American Viewpoint Society

Drawing by Hanson Booth

A POLITICAL CAMPAIGN IN FULL SWING

Political enthusiasm is a healthy sign

Party Government

A Political Party Should Live Not for Itself, but for the Good of the Whole Nation

A *DIFFERENCE OF OPINION regarding speed makes horse races.*” Just as surely it makes political parties. Our second President, John Adams, put it more elegantly when he said: “Political parties begin with human nature.”

As we have already learned in the preceding chapters, each qualified citizen has the privilege of taking an active part in his government by voting for representatives or by directly expressing his approval or disapproval of important questions. But no two men ever think exactly alike. Differences of opinion arise. Policies approved by some voters are opposed by others. If each individual had his own way there would be as many issues to decide as there are men to have opinions. In

the United States, where there are about thirty million voters, there would be about thirty million issues!

Under such conditions there would be much said, but little done. Self-government means, however, the rule of the majority; and there must be some means found to find out the will of the majority. By long experience the people in democracies have hit upon the only means of finding the will of the majority. They form themselves into great

groups, the members of which have come to an agreement on certain commonly accepted principles. Each group has its own policies and its own representatives which it wishes to elect to office in order that its policies may be carried out. These several groups struggle for victory at elections. It is agreed that after the elections are

over the policies of the successful group shall be put into operation for a definite period. It is after this manner that political parties are born and grow in power.

Democracy and Parties

Political parties are the certain result of giving people the right to think their own thoughts, to express their opinions publicly, and to control their government. In despotic autocracies a single individ-

ual, such as a czar or a kaiser, or a small group of individuals, decides matters. In such governments the mass of the people, in order to make their will felt, must resort to revolution. Even mild criticism of bad conditions is likely to bring serious punishment.

The government of France under Louis XIV had little regard for the will of the people. In those days even a slight expression of displeasure at the king's actions was considered treason-

His Clear Duty

EVERY voter should understand that an election is for the purpose of finding which is to prevail—his point of view, or that of his neighbor who differs from him. Once a decision is reached, it is the duty of every citizen to abide lawfully by that decision until the time appointed for another election, when the point at issue may again be considered.



In this country political and economic questions have always been the great issues between parties. Issues based on religion or questions between races or classes have never found favor in America. The issues of the campaign of 1920 were both political and economic. WARREN G. HARDING, now our President, who is here seen making a phonograph record of a campaign speech, was nominated by the

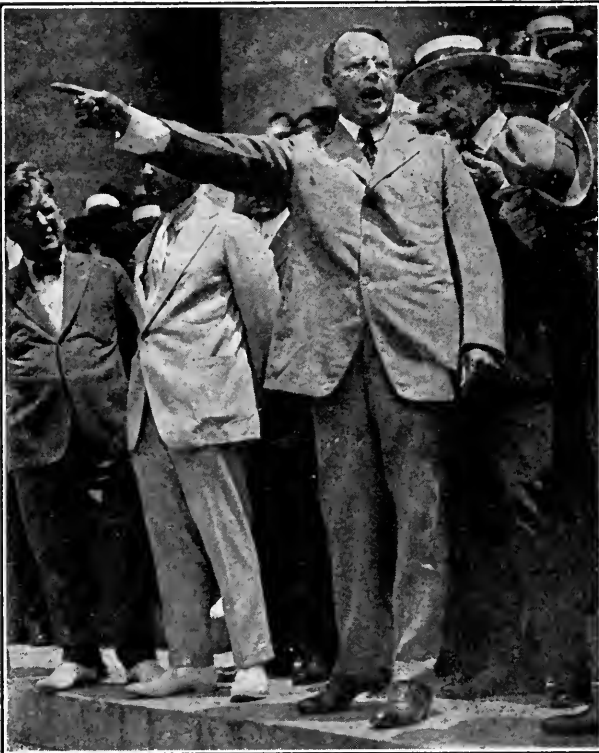

Republican party; JAMES M. COX, then Governor of Ohio, was nominated by the Democratic party.

able and rebellious. The king was the government. He was the law. His power was absolute and supreme.

At present popular government is the rule, and in popular government it is most natural that groups band together in order to express themselves effectively. Groups mean parties, and no democratic country can be run without them. All citizens enjoying the voting privilege have the right to combine with others into a political party in order to control the current policies of government according to their own views. In other words, *parties flourish under popular government because they are essential to democracy.*

Why Parties Are Organized

As has been stated before, parties are organized on account of the differences of opinion which arise over important questions. These opinions may be racial, religious, social, political or economic in character.

Most continental European countries have religious parties. Parties of this character have never appealed to the American people and have not made much headway, though religious questions are factors in all parties. Nor have parties based on racial differences ever developed to any great extent in the United States, though racial differences often enter into political organizations and policies.

In the United States political and economic questions have been the great causes of party division. In the last election (1920), the two issues of the campaign were *The League of Nations* (political), and *the reduction of taxes*

(economic). At first our country was divided over the question of whether the United States should be a real union, with the individual states subordinated to the central government, or whether the power of the central government should be limited, and the individual states allowed to be almost supreme in themselves. Those who believed in a strong central union were called *Federalists*, those taking the opposite view were called *Anti-Federalists*. This difference of opinion over the organization of the United States grew so intense that the great Civil War was fought to settle the question—"States' Rights versus the Union." Since then it has been recognized in the United States that an individual state, like Illinois or Alabama, is a part of a great whole, and that *no single state, or group of states, has the right to withdraw from the union of states*. This was a victory for those who believed in the Union.

Party Differences

Soon another issue arose between parties. They took sides on the question of *taxation*. The Republicans believed in protecting, by means of a *tariff*, American manufacturers from the competition of foreign goods. The Democratic Party adopted the policy of a *tariff for revenue only*.

Then, in 1896, still another issue arose. This time *free silver* was the great question over which Republicans and Democrats fought. The Democrats, led by William Jennings Bryan, favored free silver, while President Mc-

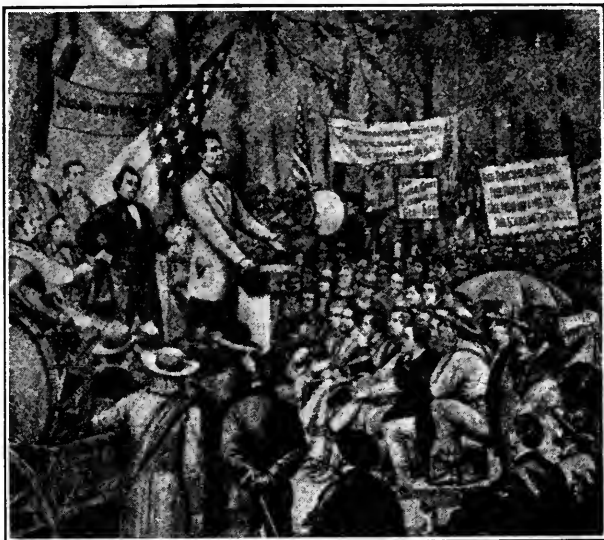

The fight waged by the two major parties in Lincoln's time was over the political question of States' Rights. LINCOLN AND DOUGLAS DEBATED this question pro and con, before large audiences in every



part of the country. Later, the economic questions relating to the tariff and "free silver" became the great issues. WILLIAM JENNINGS BRYAN, leader

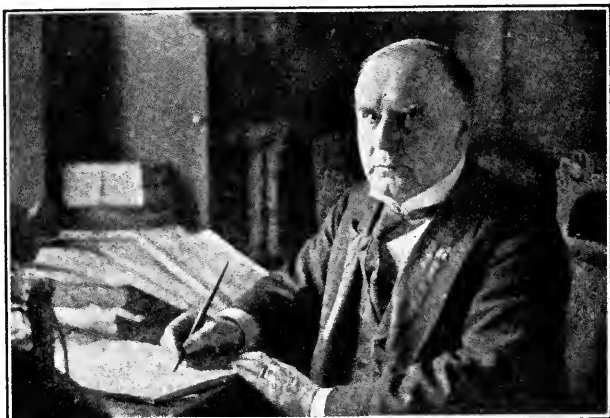

of the Democrats, and WILLIAM MCKINLEY, leader of the Republicans, were the central figures in these great political campaigns.



If American political parties are not built on questions which are economic or political, they have little chance to win at the polls. A party must put forward an issue that men and women OF ALL CLASSES, OF ALL CREEDS, OF ALL RACES, will approve. There should be only one vote—an American vote!

Kinley and the Republicans wished to keep the gold standard. Economic questions of this character have largely been the cause of the division of parties in the United States.

The kinds of issues upon which parties are built have a great effect upon the orderly progress of a nation. In general, parties based solely on racial or religious questions are to be condemned. Such issues are likely to arouse so much bad feeling as to cause serious trouble. Such problems tend to settle themselves through the common-sense of the individual and are best let alone by the government. This is why the United States Government does not officially recognize religious questions. *This is why every individual in America thinks as he pleases on religious questions.*

No Hyphen Wanted

Racial groups formed into political parties are also to be condemned. *There should be only one vote—an American vote!* Every citizen at the polls should think of himself as a part of the United States. He should have in mind the welfare of the country as a whole and not the selfish interests of any particular race. Nor should he stir up problems foreign to our interests in this country.

Some people advocate a class party, such as a political party made up solely of working men or business men. Here again selfish interests are likely to become so strong as to destroy all thought of the welfare of the country *as a whole*. Fortunately, in America, parties based on race, religion, or class distinc-

tions, do not appeal very strongly to the average American voter. American political parties, to hope for success, must include in their ranks voters from all walks of life, from all economic classes, and from all races and religions.

A Two-Party Government

In other countries the tendency is towards a number of parties, but in the United States the voters usually group themselves into two strong parties, such as *Republican* and *Democratic*. At times, however, other parties have sprung up around special issues, such as *slavery*, *prohibition*, *socialism* or *progressive legislation*. In fact, new ideas are often best brought before the public by the formation of a third party which centers its attention upon a particular problem. Then when the idea has become so well known as to attract many voters, it is either adopted by one of the two leading parties, or it carries its followers along until they are so strong in numbers as to displace one of the dominant parties as a national influence, so that, in the end, we again have two leading parties. The situation is peculiar, but United States history shows that we are wedded to a *two-party system* of government.

There are several great factors which make party government strong in the United States. One is a need for some organization which will be responsible for the acts of its candidates. People seem more inclined to support a candidate when he is backed by an organization than when he is running independently, and

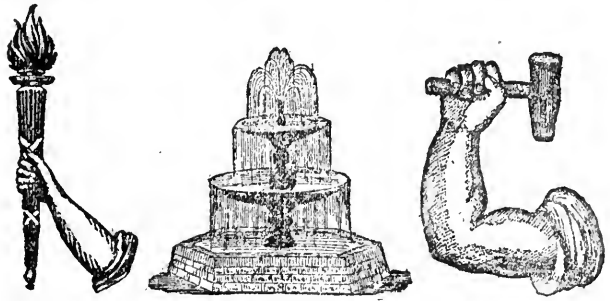

Third parties have sprung up around issues such as Prohibition, Socialism, and Slavery. Each party adopts A PARTY EMBLEM. The Socialist, Prohibition and Labor-Socialist emblems are here shown. The official emblem of the Republican Party is an

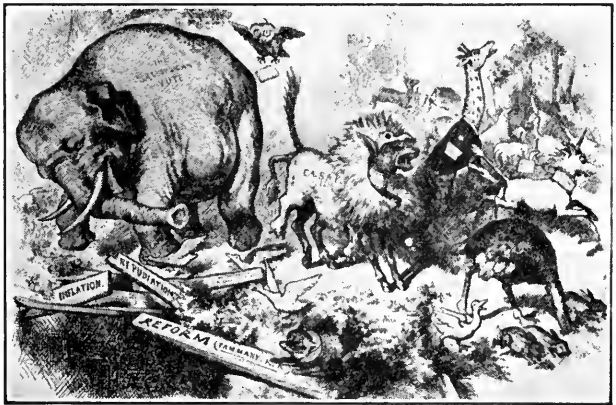

Eagle, that of the Democratic Party is a five pointed star. Often parties are better known by their cartoon emblems. Thomas Nast, a noted cartoonist of Harper's Weekly (then a Republican paper), first drew the Republican Party as an ELEPHANT and the

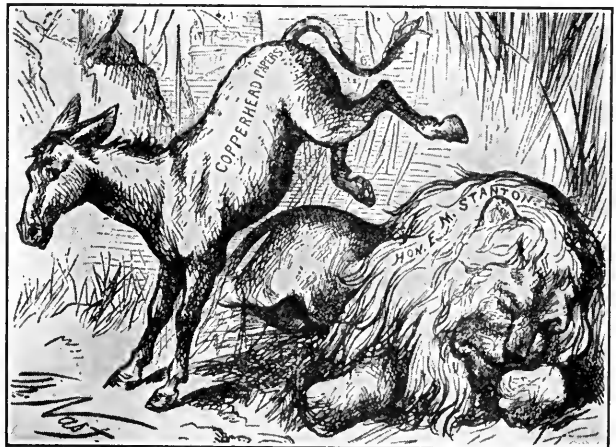

Democratic Party as a DONKEY. The Prohibition Party has several cartoon emblems: a pump, a camel and a water wagon. Local parties, too, may have cartoon emblems. For instance, the symbol of the Democratic Party in New York City is a Tiger.



Political parties are built like armies. They have leaders. These leaders are like the officers in an army—of all grades. But unlike the officers of an army, the party leaders do not issue commands. Instead, they seek to **AROUSE ENTHUSIASM** among

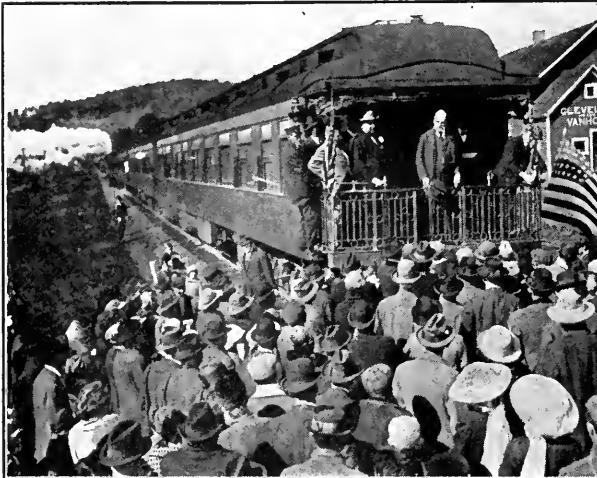

the voters; they attempt to **PERSUADE THE PEOPLE** to believe in their platform; they do



everything possible to **AROUSE CONFIDENCE** in their candidates. A great deal of work of this kind must be done to bring out the vote, for many voters think themselves too busy to vote. Some are indifferent; others are just lazy.

cannot be held responsible for his acts. When a man presents himself as candidate for the Republican or Democratic Party, it is taken for granted that the party has put its trade-mark upon him and has made itself responsible for his opinions. The voters are thus largely assured of the stand the representative will take on questions if elected.

Like an Army

Political parties are organized like armies—there are privates, and officers corresponding to corporals, sergeants, lieutenants, captains, majors, colonels, and a general.

There is a big difference, however, between an army and a political party. It is a difference in spirit. In an army a command means obedience. If a group of privates refuse to fight, or if they desert, they may be court-martialed and shot. It is not so in a political party. There everything depends upon confidence, enthusiasm, and persuasion. If the commands of a political general in charge of the fight do not appeal to the rank and file, they can get another general, or vote with another party. They may not vote at all.

Millions of voters who supported President Wilson in 1916, changed their minds in 1920 and voted for President Harding and his policies. In 1924 President Harding and the Republican Party must again ask for a public endorsement of their policies. It is possible then, as it always is in politics, that the people will swing back to the other party.

“VOTES,” the Battle Cry

Unlike a general in an army, every political leader must at-

tract voters in order to keep at the head. Only in proportion as he gets votes is he successful in winning elections. This means that it is the chief duty of a political party to elect its own people to office. *Duty* is the word to use, although some reader may question its use. It is only by having their own representatives elected to office that a group of voters may have their policies carried out. Party leaders are doing nothing wrong when they attempt, in every honest and honorable way, to fill the elective offices of the government with men who will carry their party's policies into effect.

Party Machinery

To do this effectively every party requires machinery and organization. In the United States, with its one hundred and six million people, a party must hold to its standard a vast army of voters in order to be successful. Every party must have discipline and maintain a united front, otherwise it will be defeated. Candidates must be nominated; issues must be presented clearly; platforms must be built. Every possible voter must be registered and be at the polls if the party is to win on election day, for, strange to say, a great many voters act only when prodded. If left to themselves, many, through laziness or indifference, would never take the trouble to express themselves at the ballot box. Such voters must be aroused and fired with enthusiasm.

Every party must have a *caucus*, or a *convention*, or a *primary*, in order to get its



"VOTES" IS THE BATTLE CRY in a political campaign. Indeed, Uncle Sam is as anxious as are the leaders of the parties themselves that everyone vote who can. This cartoon, drawn by Williams, shows that our Government believes it to be the duty of everyone to vote. It is our duty. Our representatives in Congress, in the State Legislature, in the City



Council, should be made to feel that they are responsible to all the people, and not to a few who, perhaps, represent a certain class. Nothing will make them feel this responsibility so much as a large vote. THEODORE ROOSEVELT was one of the great party leaders who could always bring out a big vote.

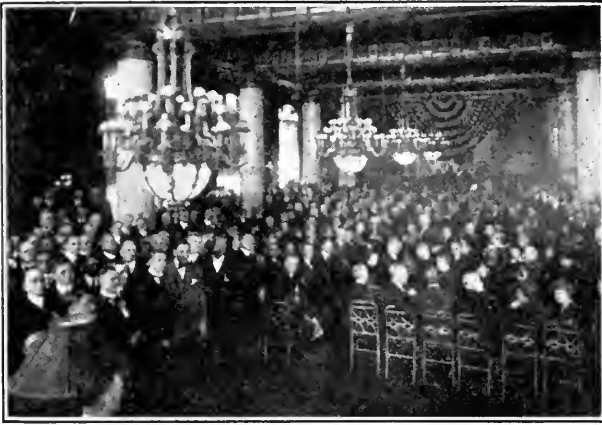

As regards the people who are in it, a political party has been likened to an army, but as regards its mechanical structure, it is like a pyramid. A political party is built like a pyramid. At the top of the pyramid is the NATIONAL COMMITTEE, made up of a chairman and one man from each state. This commit-

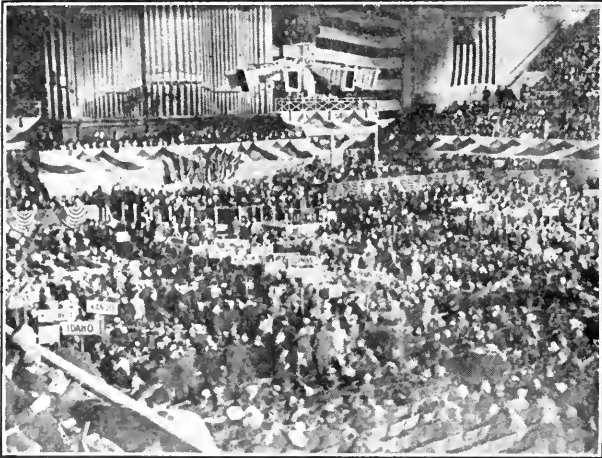

tee is chosen at the NATIONAL CONVENTION which meets every four years to nominate a president and vice-president. From the National Committee, so

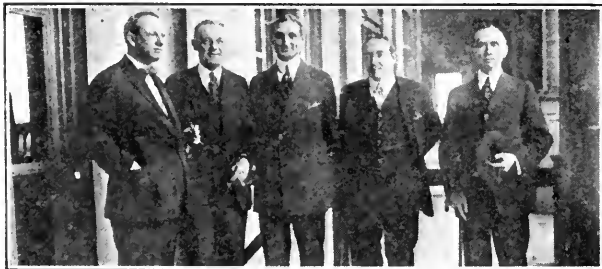

chosen, is picked a small EXECUTIVE COMMITTEE. This latter committee carries on the work of the party between one presidential election and another. At the base of the pyramid are the vast numbers of local district committees, the state and county committees, the assembly district, congressional, senatorial, judicial and aldermanic committees. The executive committee of the Democratic party in 1920 is here shown.

candidates nominated. All of this takes money and a great amount of it is required to carry on all branches of party work. To get enough money requires a great deal of effort. The result is that political parties in the United States have taken a place among the most elaborate and most efficient organizations of their kind in the world.

Built Like a Pyramid

As regards the people that are in it, a political party has just been likened to an army, but as regards its mechanical structure, it may be likened to a pyramid. At the base of the pyramid are the vast numbers of local district committees. At the apex is the *National Committee*, composed of a few men, who represent the thousands in all the divisions of the party.

The National Committee

The members of this committee are chosen every four years at the *National Convention* of the party. One committeeman is elected from each state. This committee has a chairman who is the business manager of the party. It has also a small executive committee. Ordinarily this chairman and his executive committee carry on the national activities of the party between the time of one presidential election and another. One very important task of this committee is the selection of a place of meeting for the national convention which nominates candidates for president and vice-president of the United States.

The National Convention

This national convention meets once every four years. Every

political party has one. It includes delegates from every state, each state having twice as many members in this national convention as it has representatives and senators in Congress. A national convention usually numbers about one thousand members. In addition to nominating a president and vice-president, the convention adopts a *party platform* which states its policies to the voters of the nation. It also names a national committee for the next election.

Each party also has a *state committee*, which does in the state about what the national committee does in the nation. Among the duties of the committee is the calling of the state convention which nominates state officers and makes a state party platform. Also it conducts state campaigns and looks after the general welfare of the party within the state.

Each party also has *county* and *city committees* which attend to local party interests. All these committees, on account of their first-hand contact with the voter, play an important part in a political organization. In the county committees are to be found the party officials of the local election district.

Other Committees

In every party there are also a number of other committees, representing different governmental districts or groups of officials, such as an *assembly district committee*, a *judicial committee*, a *congressional committee*, a *senatorial committee*, or even an *aldermanic committee*. Through its committees and their officers, a party is molded



A NATIONAL CONVENTION MAKES HISTORY. At such a convention there are present delegates from every state—about 1,000 delegates in all. The rule is that each state sends twice as many members as it has representatives and senators in Congress.



In addition to **NOMINATING A PRESIDENT AND VICE PRESIDENT**, the convention adopts a platform. This platform aims to state the policy of the party. After the convention is over, every effort is made



through the executive, state, county and other committees of the party to win the election, which is held on the first Tuesday following the first Monday in November, about four months after the National Conventions. On the night of the election great crowds in all the cities **WATCH FOR THE ELECTION RETURNS**. This immense crowd is watching the returns in Times Square, New York City.



In the old days, **THE DESIRE FOR OFFICE AND THE SPOILS OF OFFICE**, were likely to make political managers adopt methods in the campaign that were dishonest. These corrupt methods are not so common now. Still dishonest methods even to-day



have a way of cropping out in political campaigns. **THE BALLOT BOX MUST AT ALL TIMES BE CAREFULLY GUARDED BY ALL THE CITIZENS.** An electorate that cannot be corrupted, and elections that show the true choice of intelligent voters are the great safeguards of a democracy.

into a complete whole from the bottom to the top of the pyramid.

Corrupt Methods

Party zeal, the desire for office and the spoils of office, are likely to make political managers look with leniency on dishonest methods. Often winning becomes the supreme end of the party, and dishonest means are made to appear justifiable. Partisanship of this character was much worse a few years ago than it is now. Still dishonest methods have, even to-day, a way of cropping out in political campaigns. This must always be watched by the voter. In former days corruption and dishonest methods, especially in municipal elections, were common. Voters were often bribed openly. The ignorant voters were grossly deceived and at times threatened with violence, and other illegal methods were frequently used at elections. In many cases a political campaign became a battle of political wits, each party attempting to outdo the other in dishonesty.

Political rivalry is a good thing just so long as the methods used are honest and above-board. Voters may be attracted, but the election must be free from corruption. Political enthusiasm is a healthy sign, but when carried to the point of dishonesty it is better that the political party using these methods be defeated at the polls. No political issue is so important to the nation as to justify corrupt political methods. It is far better to have a poor measure adopted in a fair election than to have good policies adopted by unfair methods. *Fraud*

strikes at the very heart of democracy; it should never be tolerated by the voter.

Winning and Losing Elections

The spirit with which parties in this country accept defeat is most important. A sportsman-like acceptance of the verdict of the majority at the polls is the sign of a healthy government. If this state of mind is not held by the voter, or the party, pre-election rivalry is likely to be carried over and lead to serious differences.

Every voter should understand that an election is for the purpose of finding out which is to prevail—his own point of view, or that of his neighbor who differs from him. *Once a decision is reached it is the duty of every citizen to abide lawfully by that decision until the time appointed for another election, when the point at issue may again be brought up for consideration.* As soon as a candidate for the presidency of the United States is elected, he becomes the *President of us all*, and as such should command the respect and loyalty of every citizen. Rousseau, the great political philosopher who so influenced French thought, emphasized this important point in his celebrated book *The Social Contract*. In some countries where this spirit of fairness is not clearly understood, the defeated candidate and his supporters become a revolutionary party. In such a case democracy does not prevail, but *anarchy*.

Issues Should Decide

It is much better in a democracy to give support to a weak



A political campaign may become intense, even bitter, as election day draws near. Yet, after the decision of the voters is once made the defeated candidates **SHOW TRUE SPORTSMANSHIP** by congratulating and offering assistance to the victors. It is



well that this is so. In some countries where this principle of fairness is not clearly understood, the defeated candidate and his supporters become a revolutionary party. In such a case democracy does not prevail, but *anarchy*. In the United States, as soon as the candidate for the presidency is elected, he becomes the **PRESIDENT OF ALL**, and as such should command the respect and loyalty of all.

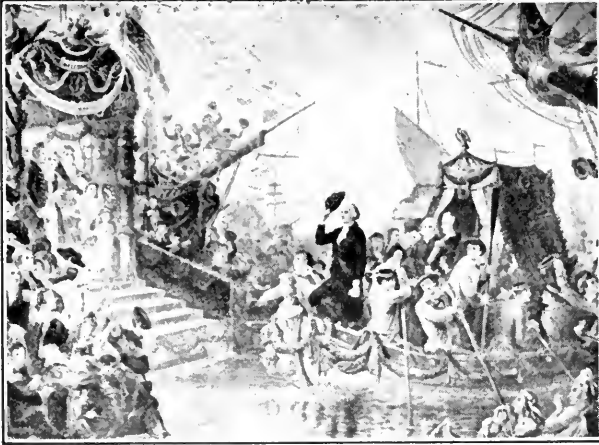

Happily for this country, it has never wanted for great leaders in any crisis in its national affairs. In the dark revolutionary days WASHINGTON was the great leader. He is here shown landing in New York

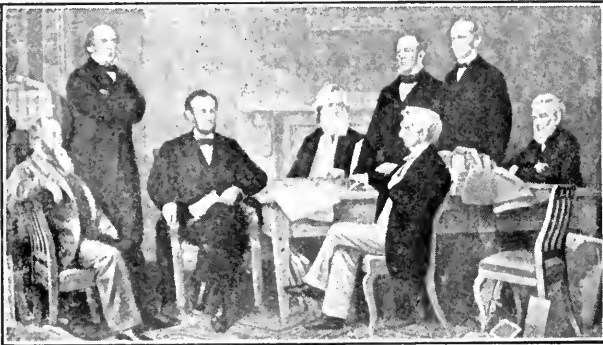

for his first inauguration, 1789. He was our only President who was unanimously elected by the people. Then arose the great and wise and patient LINCOLN. This is Lincoln's cabinet. This body of men guided the nation through the dark days of the Civil War.



A great leader, whose memory Americans respect, was ROBERT E. LEE, commander of the armies of the South in the Civil War.

official who is honestly elected, than it is to attempt to get rid of him by violence. Democracy has been organized for the purpose of deciding issues by votes and reason, not by force. Of course mistakes are made in democratic governments just as they are made in other forms of government, but as the late Theodore Roosevelt said in one of his campaign speeches, *the people in a democracy have the satisfaction of making their own mistakes*. The wrong man may be elected, the wrong policies may be adopted, but democratic government gives us the privilege of correcting mistakes and changing our officials at certain lawfully established times.

The Political Boss

A political party that has existed for a long time or has been in power for a number of years is in danger of falling into the hands of a few men, or even one man, who use the party for selfish ends. Such a party exists not so much as a means of expression for the voter but as an agent of corruption.

Yet not all organizations are evil which pass into the hands of a single strong leader, or a few leaders. A successful business is usually the product of the brains of one man who gives his whole time to its success. Leadership is harmful only when it is used to further bad practices. Leadership by able and honest men is an absolute necessity. *George Washington*, the first President of the United States, was a leader among men. *Abraham Lincoln*, a great party leader, often condemned in his

day, is now honored and revered by every American.

A citizen must always realize that bad, dishonest leadership is possible only because the average voter allows it. The boss is crafty and quick to take advantage of the weaknesses of human nature. He holds his position only through the indifference, the apathy, the prejudices and weaknesses of the average voter. Unhindered, he fills offices with rascally *henchmen*, thereby strengthening his position. He counts on a certain proportion always voting the same ticket, and on another group not voting at all. He knows that many people inherit their opinions from their parents. He also knows that many never think for themselves but accept the opinions of those with whom they associate. He realizes that many people look upon their government as something outside of their every-day life—something that does not concern them excepting on election day and possibly not then unless the issues are important.

Ask any man on the streets to name the officials for whom he voted at the last election. The President, the Governor, the Mayor and a Senator, he may mention without hesitation, but it is probable that he will not know the name of a single minor official for whom he voted. He made his cross in a square opposite an emblem that stood for a

ticket; *his not to reason why!* Yet his thoughtless act along with the same lack of reasoning on the part of thousands of other mis-called voters, is the power which supports the corrupt machine and the dishonest boss.

The foregoing statements about party abuses must not blind the reader to the great good that is to be found in political parties. *Parties form one of the great educational forces that influence the American voter.* They awaken interest. They stir up enthusiasm. They spread information about political questions. They give the voter the opportunity to unite with others for effective action, and they are constantly trying to make all men and women realize their rights and obligations as citizens.

This educational work is especially important in a country like the United States where there are so many different sections and people. There must be some binding force. As yet no organization has been developed that is equal to a political party in its power to unite diversified sections and people. Still there is much that should be improved, but to improve and perfect we must work from the bottom up. The important causes which wreck or make political parties are you, Mr., Mrs. and Miss Citizen! *What are YOU going to do about it?*

“I know no South, no North, no East, no West to which I owe allegiance.”
—Robert T. Winthrop.

✦ ✦ ✦

“We join ourselves to no party that does not carry the flag, and keep step to the music of the Union.”—Rufus Choate.

✦ ✦ ✦

“We cannot become thorough Americans if we think of ourselves in groups. America does not consist of groups.”—Woodrow Wilson.

✦ ✦ ✦

“Democracy is a political principle, the aim of which is that government shall not be controlled by one class or group, but rather by the whole populace.”
—A. S. Sachs.



Hanson Booth

©The American Viewpoint Society

Drawing by Hanson Booth

VOTING: THE GREAT PRIVILEGE OF THE CITIZEN

The United States has today what is called a universal suffrage

Our Vote in Government

The Vote is the Greatest Gift of the State to Its Political Children—
Vote at Every Opportunity

OUR VOTE IS OUR VOICE IN THE GOVERNMENT. It is the method which democracies use to give to their qualified citizens a legal part in deciding what the government shall do.

Groups of citizens may hold meetings, write letters, send in petitions and memorials to their representatives, and in many other ways express their opinion of what the government is doing. Thereby they doubtless influence the government somewhat through the force of public opinion. Legally, however, they decide the course of government *only through voting*.

Voting is the great privilege of the citizen. Originally this privilege was granted only to those who were born into certain noble families, or to individuals who had made much money or rendered special public service. Two hundred years ago it was thought that only the noble-born or the well-to-do had a right to say what the government should do. The rank and file of people were politically of no account. They could express themselves in indirect ways, but not legally through the vote. Gradually, however, this idea has been displaced as countries have become more democratic. To-day the privilege of voting is given in

the United States practically to all citizens over twenty-one who can meet simple demands of residence, of a small tax, education, and character, asked for by the government of a state.

What Is an Electorate?

In the newspapers one often reads of *the electorate*, that is, the body of citizens legally qualified to vote at a certain stated time, in a stated way. Such a group is an essential part of government. Governments more and more are putting greater responsibilities upon their voting citizens, the electorate, and are asking them to take a more important part in governmental decisions.

A voter influences government in several ways. In the first place he is given the opportunity to elect the most important official,

World Democracy

HISTORY in the past has been written almost entirely about kings and queens and lords and ladies of high degree . . . Now history must be written in terms of the common man, of the man in the street, of the people. Government is now in their hands. What the world will be one hundred years from now must be determined by the votes of every-day men and women.

or officials, who execute the law of the land. Every voter, for example, has the opportunity of voting, in the United States, for the *electors* of the *President and Vice President*. In each of the forty-eight States of the Union, he has the privilege of voting for the *Governor* and some of the more important officials. In cities he votes for a *Mayor*, or, more often of late, a *City Commissioner*.

In the second place, a voter has the privilege of choosing those individuals

"Shall the bonds of the City School District of the City of Cleveland be issued in the sum of Two Million Dollars (\$2,000,000.) for the purpose of providing buildings for the public library of said District, for furnishing the same, and for paying the cost and expense thereof."

FOR THE ISSUE OF BONDS

AGAINST THE ISSUE OF BONDS

"In favor of the expenditure of \$2,000,000.00, in addition to the proceeds of the bond issue of \$1,250,000.00, heretofore authorized, for the purpose of erecting and completing a building for a county jail, court rooms for Insolvency Court, Criminal Court and Prosecuting Attorney's Office. (It has been agreed that about half the space in this building will be leased to the City of Cleveland for Central Police Station, police court, prosecutor's office, probationers' offices and other similar municipal purposes.)"

"Against the expenditure of \$2,000,000.00, in addition to the proceeds of the bond issue of \$1,250,000.00, heretofore authorized, for the purpose of erecting and completing a building for a county jail, court rooms for Insolvency Court, Criminal Court and Prosecuting Attorney's Offices. (It has been agreed that about half the space in this building will be leased to the City of Cleveland for Central Police Station, police court, prosecutor's office, probationers' offices and other similar municipal purposes.)"

The voters in this country cast ballots for President, Vice President, governors of the states, mayors and aldermen of the cities, senators and representatives. In many cases they vote for judges. **AMENDMENTS TO THE FEDERAL AND STATE CONSTITUTIONS** are directly or indirectly referred to the



voters. The wisdom of **SPENDING LARGE SUMS OF MONEY** for street car systems, for example, is often referred to the electorate for decision.

who are to determine, through legislation, what the government shall do and how it shall be done. He chooses, in the Federal Government of the United States, the *senators* and the *representatives*. In the state government, he elects the *assemblymen* and the *senators* to the state legislature. In the city government, he elects the *aldermen* or *councilmen*.

Sometimes the voter also elects the people who are to judge his acts. This privilege is not granted in all cases. In the Federal Government this task is given to the President, subject to the approval of the Senate. Most countries believe that better and more independent judges can be secured through appointment than by an election. This is the purpose of giving the President power to appoint all *Federal Judges*.

In the state governments and local governments, however, the voters usually elect the *judges*, although in some states, Massachusetts for example, they are appointed by the Governor.

The voter not only elects executive, legislative and judicial representatives, but in many cases he acts directly on government policies through his vote. *Amendments to State Constitutions* are often referred to the electorate for decision. The wisdom of spending large sums of money on proposed public works of a state or city is often referred to it. About one-third of the States in the Union have accepted the idea of a *referendum* whereby decisions on many important laws are referred directly to the people, provided a

sufficient number request it by petition, or the Legislature or Constitution so determines.

Citizens and Voters

Very often many people confuse *citizenship* and the *suffrage*. Not all citizens vote. Some citizens are allowed to vote; others are not.

The Fourteenth Amendment of the Constitution of the United States states: "*All persons born and naturalized in the United States and subject to the jurisdiction thereof are citizens of the United States and of the states wherein they reside.*" This amendment was passed in order to make clear that citizenship in the United States is a national matter. *Citizenship cannot be bestowed or withdrawn from any individual by state action. Your citizenship is a national gift.*

But because you are a citizen of the United States it does not follow that you have *the right to vote* wherever you may be in the United States. A citizen, to be able to vote, must meet certain qualifications which a *state government* thinks necessary. Whether you may vote or not is left to the decision of each individual state.

Vote Safeguarded

Every state in the union has thrown safeguards around the vote. Before you are allowed to vote you must meet certain tests. These tests vary greatly in the different states. You may be required to pay a certain tax, or to be of age, or to have lived in a state, a county, or an election district for a definite length of time. It may be required that you be



Often we confuse citizenship and the suffrage. When a man or woman **BECOMES A CITIZEN** it does not follow that he or she can vote. You are a

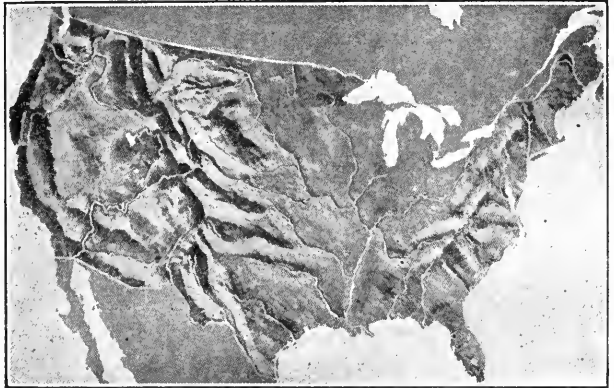

citizen **OF THE WHOLE UNITED STATES**, but one state gives you the right to vote. Before you are allowed to vote you must meet certain tests. These tests are made by the several states. Some states



require that you **PAY A CERTAIN TAX**, or be of age, or have lived in the state or election district a definite length of time or can read and write. Tests vary in the different states.



A CENTURY AGO only those who owned property could vote. Now it is felt that property tests ex-



clude the working man and place the control of the Government in the hands of the rich. Everyone will admit CHILDREN SHOULD NOT VOTE. In countries with many immigrants, where there are large



numbers of NEWLY-NATURALIZED VOTERS each year, it is felt that an individual should live in a state and in a certain district within the state a definite length of time before he can vote.

able to read and write and meet certain moral and mental tests.

Property Qualifications

It has already been stated that a century ago only those individuals holding property were thought to have a permanent interest and thus a share in government. In those days the privilege of voting was limited to those who held a certain amount of property, or possibly to those who paid so many dollars in rent. Such qualifications, in America, have almost entirely been done away with. *It is felt that property tests exclude the working man and place the control of the government in the hands of the well-to-do, thereby making government a class matter.* In some states, however, a poll tax still remains a voting requirement. Such a tax is a direct charge of one to three dollars, usually levied upon each citizen.

Age Qualifications

Everyone will admit that children should not vote, since their minds are not developed. Also their interests are looked after by their fathers and mothers. Some age must be fixed upon as the legal age for voting. This age in practically all countries has been set at *twenty-one*.

Residence Qualifications

In the United States, Australia, New Zealand, the South American States, and Canada, where the population is constantly moving and changing on account of immigration and travel, where there are large numbers of newly-naturalized voters each year, it is felt that an individual should live in a state and in a

certain district within the state a definite length of time before voting. Such a period of residence is required in all states of the United States. In New York before voting the citizen must live thirty days in his election district, four months in the county, and one year in the state.

Sex Qualifications

Women, up to very recent times, could not vote. Their interests, it was felt, were looked after sufficiently by their husbands or fathers or other male members of the family. Many women, especially those in business or working in factories, were dissatisfied. In consequence agitation was carried on for many years to secure the vote. Gradually state after state, at first principally the western states, granted this privilege. *The Nineteenth Amendment to the Constitution of the United States became law after three-quarters of the states had ratified it.*

Other Qualifications

None will deny that criminals, lunatics and idiots should be denied the right to vote. Less clear, however, is the need for educational tests, such as reading and writing, for which there seems to be an increasing demand. It is thought that the ability to read and write is something which every voter should have. How can an illiterate person read the news or otherwise gain the knowledge required to vote intelligently on election day? A number of states—Massachusetts and New York are good examples—require such qualifications. When all the



The following photographs show the steps taken by a voter when casting his ballot. They were made under the direction of the President of the New York City Board of Elections, John R. Voorhis. This picture gives a general view of the INSIDE OF A POLLING PLACE. Here is shown a "close up" view of



the ELECTION OFFICIALS who must be present when the votes are being cast. When a voter enters



a polling place HE MAY BE CHALLENGED by a voter or by any election official. If challenged, he must give all information requested by an Inspector of Elections. This information must tally with that which he gave about himself on Registration Day, and which then was recorded in a book called Register of Electors.

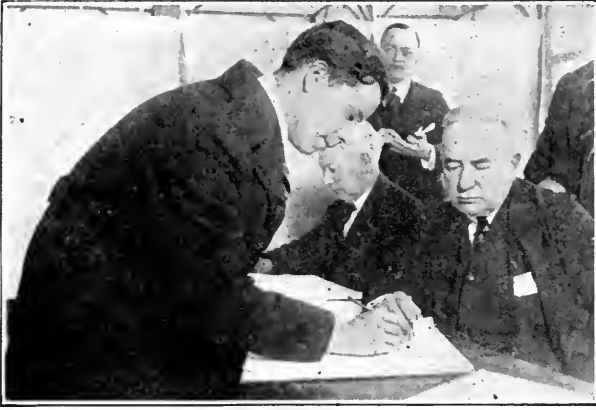

The voter then **MUST SIGN HIS NAME** in the Register of Electors' book. His signature is compared by an election official to the signature that he made

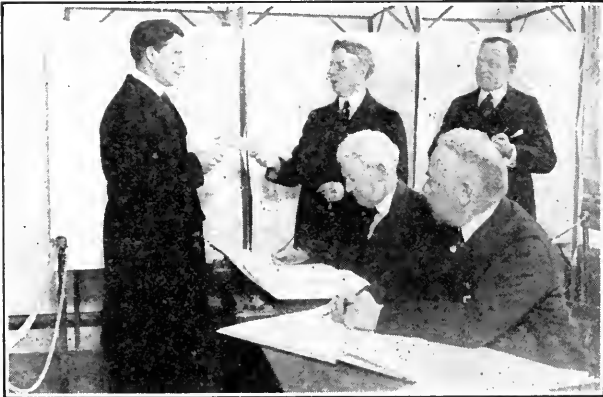

on registration day. If the election officials are satisfied that the man is entitled to a vote, he is then **HANDED A BALLOT**. Then he **GOES INTO THE**

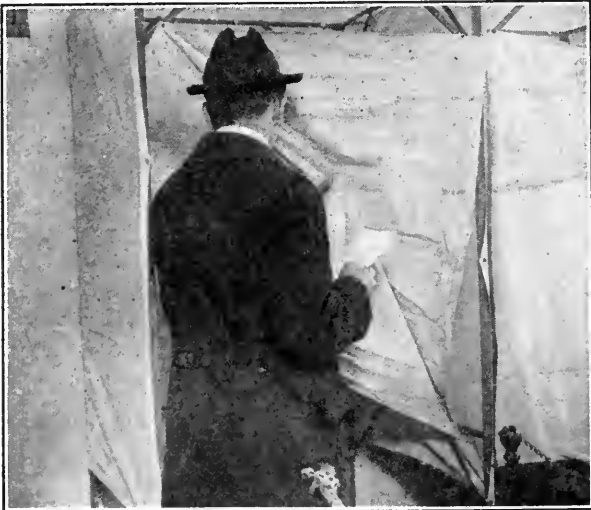

VOTING BOOTH alone. The voter must mark his ballot with a black crayon pencil—one is always found in the booth. If he uses his fountain pen or a colored pencil to mark his ballot, his vote becomes void. If he makes a mistake in marking his ballot he must not erase. He should ask for another ballot.

qualifications have been met the voter acquires the legal right to exercise the privilege of voting.

The Widening of the Suffrage

Despite the fixing of these tests, all of which prevent the unfit from voting, the past century brought great changes. It was a period which began with the few who might vote, and ended with the day when practically everybody over twenty-one years of age has the privilege. In the United States at the time of the Revolution voting was very much restricted. It is estimated that at that time only one person in thirty could vote, although in Massachusetts about one in fifteen had the franchise. By 1870 all men who met certain simple qualifications had the privilege. At the present time women, as well as men, exercise this privilege. Restrictions have one by one been taken off, until we have what is called a *universal suffrage*. Today more than one out of every four people in the United States are eligible to vote.

What is true of the United States is also true of the world. One hundred and twenty-five years ago there were only a few countries in the world where people had the privilege of electing their own representatives. The United States was the outstanding example. Gradually the principle of the right of people to decide political questions for themselves and to elect representatives who will carry on government according to the popular will have been extended, until today the large majority of the governments of the world are run in this manner.

This is a tremendous world responsibility for the citizen to carry. It is a dream that people have hoped for and looked forward to for many centuries. History in the past has been written almost entirely about kings and queens, and lords and ladies of high degree. Kingdoms and oligarchies and aristocracies, and other despotic forms of government long held the center of attention. Now history must be written in terms of the common man, of the man in the street, of the people. Government now is in their hands. *What the world will be one hundred years from now must be determined by the votes of every-day men and women, not by the decisions of autocrats or oligarchies.*

Registration

In order to vote, a citizen must *register*, must have his name placed among the legally qualified voters. This registration is taken as a measure of precaution. If, on election day, everyone who wished to vote just went to the polls without any system to identify him, such as registration gives, it would be very difficult for the election officials in charge of the polls to prevent illegal voting. To investigate the qualifications of the voters at such a busy time would cause much confusion and wrangling and untold delay.

Some Voting Regulations

In some states the list of qualified voters is made up before election day by a group of officials, such as the *selectmen* of a town. In other states, and this is true of most of them today, an individual must register,

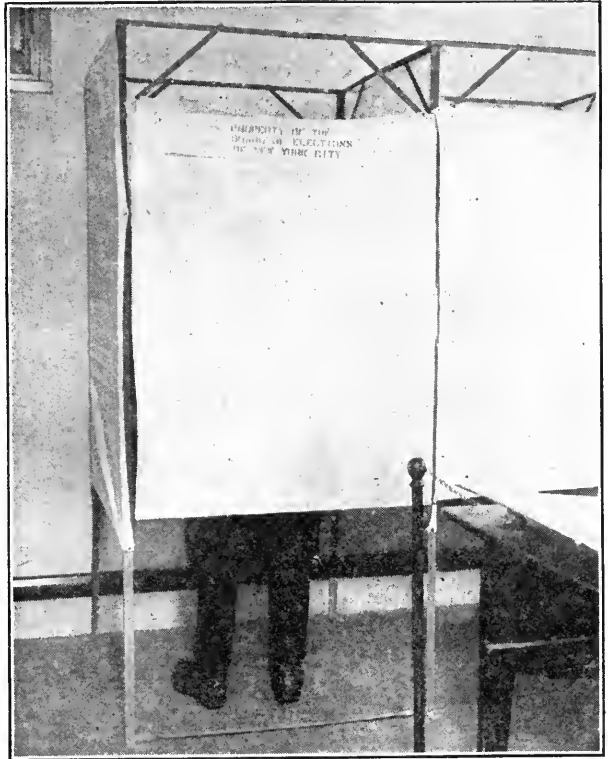

In the voting booth he MARKS HIS BALLOT IN SECRET. No one can know how he votes. This matter of secrecy is very important. If a voter had



to mark his ballot in the open or tell the election officials how he wished to vote, an attempt might be made to force him to vote against his desire. After the voter has marked his ballot he comes out of the booth and HANDS HIS FOLDED BALLOT TO AN ELECTION OFFICIAL.

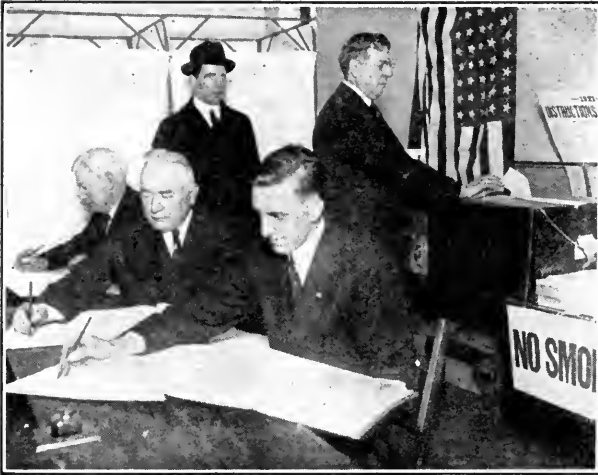

An election official, then, in the presence of the voter, tears off the stub of the ballot and **DEPOSITS THE STUB IN ONE BOX AND THE BALLOT IN ANOTHER BOX.** When the votes are counted, the number of stubs must equal the number of ballots.



In election districts where **VOTING MACHINES** are used, the process of voting is the same, but instead of marking a ballot, the voter operates a machine. This, too, is done in secret. Franklin D. Roosevelt, Democratic nominee for Vice President in the election of 1920, is here seen about to operate a voting machine.

personally, before an *election board*, or *registrar of voters*, that is, he must appear before certain officials, appointed by the government, and give his name, address, length of residence in the district, occupation, citizenship, and any other particulars which may be asked for. It is also necessary that he sign his name in the registration book. All statements are verified before the election takes place. In the larger cities the police go from door to door with the list of registered voters in order to find out if false statements have been made.

In large cities, where illegal voting is less easily detected than in country districts, a voter may be required to register every year. In country districts, one single registration may do as long as the voter lives in that district. This is possible because the voter is known in the neighborhood.

The Secret Ballot

The manner in which a citizen records his choice at the polls is very important. On the day of election a citizen must have his right to vote verified before he is allowed to enter the voting booth, and, in some states, as a final step he must sign his name in the *poll book* so that his signature may be compared with the one he made in the registration book on a previous day. After satisfying the election officials that he is qualified to vote, he is then given an official ballot.

This matter of secrecy is very important to the individual voter. If you had to mark your ballot in the open or tell the election officials how you wished to vote,

an attempt might be made to induce you to vote contrary to your desire. Today no one knows how you vote. This is your own personal business. *The introduction of the official secret ballot marks great progress in the holding of fair and honest elections.*

More Polling Regulations

After the voter has selected his candidates and made the proper voting marks, he must fold his ballot and hand it to an election official. As this official takes the ballot he tears a stub from it and places the stub in one box and the ballot in another. The number of the stubs and the ballots must correspond at the final counting of the votes. This makes it almost impossible to *stuff* the ballot-box.

There are many other precautions taken against the use of dishonest methods at the polls. Every state has them. Two stand out more prominently than the rest: party workers are not allowed to approach voters within a restricted area about the polls, and only a definite number of party watchers may be present when the votes are being counted. Of course it is understood that every election official must keep strictly to election laws, or be subject to prosecution. Abuses sometimes crop up, but everything considered, an election in the United States today is fairly and honestly conducted.

Kinds of Ballots

These official ballots may be made up in many different ways. How they are made up is an extremely important matter to the voter. Generally there are two

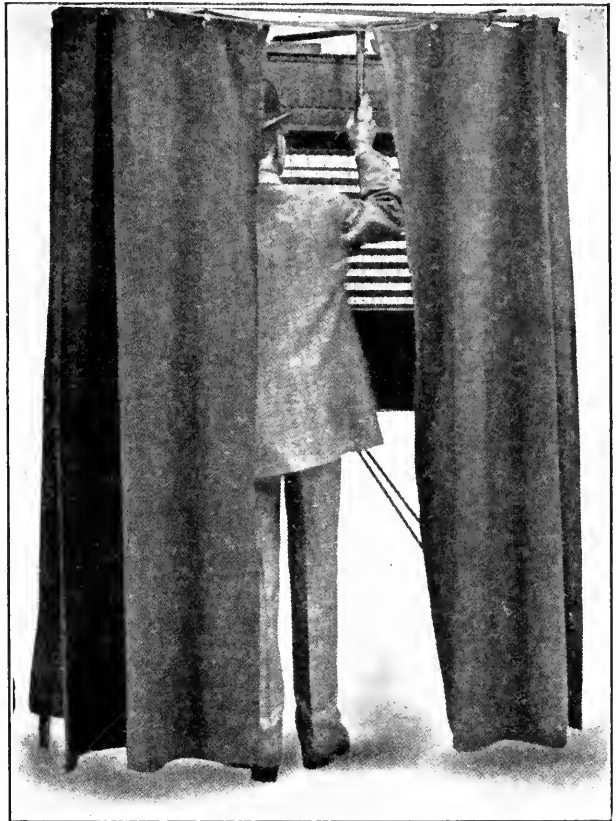

A voter cannot operate a machine until he has pulled the lever that CLOSSES THE CURTAIN. He

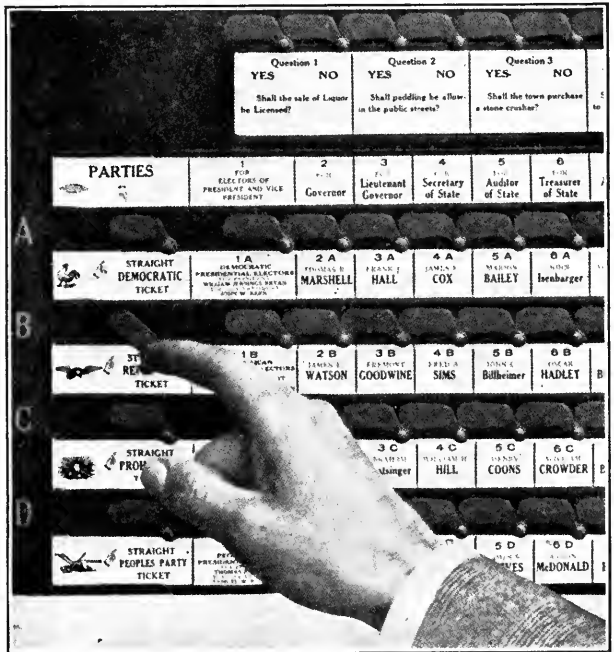

casts his ballot by PULLING DOWN A SMALL LEVER underneath the name of the candidate for whom he wishes to vote.

1. To vote for a candidate on this ballot make a single cross X mark in one of the squares to the right of an emblem opposite his name.
2. To vote for a candidate not on this ballot write his name on a blank line under the candidates for that office.
3. Mark only with a pencil having black lead.
4. Any other mark or erasure on this ballot is unlawful.
5. If you tear, or deface, or wrongly mark this ballot, return it and obtain another.

<p>1</p> <p>ASSOCIATE JUDGE OF THE COURT OF APPEALS.</p> <p>Vote for one!</p> <table border="1" style="width: 100%; border-collapse: collapse;"> <tr> <td style="width: 20%; text-align: center;"> <input type="checkbox"/> </td> <td style="width: 80%;"> WILLIAM S. ANDREWS.....Republican </td> </tr> <tr> <td style="text-align: center;"> <input checked="" type="checkbox"/> </td> <td style="text-align: center;"> TOWNSEND SCUDDER.....Democratic </td> </tr> <tr> <td style="text-align: center;"> <input type="checkbox"/> </td> <td style="text-align: center;"> HEZEKIAH D. WILCOX.....Socialist </td> </tr> </table>	 <input type="checkbox"/>	WILLIAM S. ANDREWS.....Republican	 <input checked="" type="checkbox"/>	TOWNSEND SCUDDER.....Democratic	 <input type="checkbox"/>	HEZEKIAH D. WILCOX.....Socialist	<p>2</p> <p>MAYOR.</p> <p>Vote for one!</p> <table border="1" style="width: 100%; border-collapse: collapse;"> <tr> <td style="width: 20%; text-align: center;"> <input type="checkbox"/> </td> <td style="width: 80%;"> HENRY H. CURRAN.....Republican </td> </tr> <tr> <td style="text-align: center;"> <input checked="" type="checkbox"/> </td> <td style="text-align: center;"> JOHN F. HVLAN.....Democratic </td> </tr> <tr> <td style="text-align: center;"> <input type="checkbox"/> </td> <td style="text-align: center;"> JACOB PANKEN.....Socialist </td> </tr> <tr> <td style="text-align: center;"> <input type="checkbox"/> </td> <td style="text-align: center;"> T. DE HUNT.....Farmer-Labor </td> </tr> </table>	 <input type="checkbox"/>	HENRY H. CURRAN.....Republican	 <input checked="" type="checkbox"/>	JOHN F. HVLAN.....Democratic	 <input type="checkbox"/>	JACOB PANKEN.....Socialist	 <input type="checkbox"/>	T. DE HUNT.....Farmer-Labor	<p>5</p> <p>JUSTICES OF THE SUPREME COURT FOR THE SECOND JUDICIAL DISTRICT.</p> <p>Vote for three!</p> <table border="1" style="width: 100%; border-collapse: collapse;"> <tr> <td style="width: 20%; text-align: center;"> <input type="checkbox"/> </td> <td style="width: 80%;"> HARRY E. LEWIS.....Republican </td> </tr> <tr> <td style="text-align: center;"> <input type="checkbox"/> </td> <td style="text-align: center;"> FRANK S. GANNON, JR.....Republican </td> </tr> <tr> <td style="text-align: center;"> <input checked="" type="checkbox"/> </td> <td style="text-align: center;"> MITCHELL MAY.....Democratic </td> </tr> <tr> <td style="text-align: center;"> <input checked="" type="checkbox"/> </td> <td style="text-align: center;"> WILLIAM F. HAGARTY.....Democratic </td> </tr> <tr> <td style="text-align: center;"> <input type="checkbox"/> </td> <td style="text-align: center;"> JOSEPH A. WHITEHORN.....Socialist </td> </tr> </table>	 <input type="checkbox"/>	HARRY E. LEWIS.....Republican	 <input type="checkbox"/>	FRANK S. GANNON, JR.....Republican	 <input checked="" type="checkbox"/>	MITCHELL MAY.....Democratic	 <input checked="" type="checkbox"/>	WILLIAM F. HAGARTY.....Democratic	 <input type="checkbox"/>	JOSEPH A. WHITEHORN.....Socialist	<p>8</p> <p>REGISTER.</p> <p>Vote for one!</p> <table border="1" style="width: 100%; border-collapse: collapse;"> <tr> <td style="width: 20%; text-align: center;"> <input type="checkbox"/> </td> <td style="width: 80%;"> EDWARD H. MADDOX.....Republican </td> </tr> <tr> <td style="text-align: center;"> <input type="checkbox"/> </td> <td style="text-align: center;"> JAMES A. McQUADE.....Democratic </td> </tr> <tr> <td style="text-align: center;"> <input type="checkbox"/> </td> <td style="text-align: center;"> IDA CROUCH HAZLETT.....Socialist </td> </tr> <tr> <td style="text-align: center;"> <input type="checkbox"/> </td> <td style="text-align: center;"> CHRIS RILEY.....Farmer-Labor </td> </tr> <tr> <td style="text-align: center;"> <input type="checkbox"/> </td> <td style="text-align: center;"> EDWARD M. WARING.....Prohibition </td> </tr> <tr> <td style="text-align: center;"> <input type="checkbox"/> </td> <td style="text-align: center;"> FRED J. DEVERALL.....Single Tax </td> </tr> </table>	 <input type="checkbox"/>	EDWARD H. MADDOX.....Republican	 <input type="checkbox"/>	JAMES A. McQUADE.....Democratic	 <input type="checkbox"/>	IDA CROUCH HAZLETT.....Socialist	 <input type="checkbox"/>	CHRIS RILEY.....Farmer-Labor	 <input type="checkbox"/>	EDWARD M. WARING.....Prohibition	 <input type="checkbox"/>	FRED J. DEVERALL.....Single Tax
 <input type="checkbox"/>	WILLIAM S. ANDREWS.....Republican																																						
 <input checked="" type="checkbox"/>	TOWNSEND SCUDDER.....Democratic																																						
 <input type="checkbox"/>	HEZEKIAH D. WILCOX.....Socialist																																						
 <input type="checkbox"/>	HENRY H. CURRAN.....Republican																																						
 <input checked="" type="checkbox"/>	JOHN F. HVLAN.....Democratic																																						
 <input type="checkbox"/>	JACOB PANKEN.....Socialist																																						
 <input type="checkbox"/>	T. DE HUNT.....Farmer-Labor																																						
 <input type="checkbox"/>	HARRY E. LEWIS.....Republican																																						
 <input type="checkbox"/>	FRANK S. GANNON, JR.....Republican																																						
 <input checked="" type="checkbox"/>	MITCHELL MAY.....Democratic																																						
 <input checked="" type="checkbox"/>	WILLIAM F. HAGARTY.....Democratic																																						
 <input type="checkbox"/>	JOSEPH A. WHITEHORN.....Socialist																																						
 <input type="checkbox"/>	EDWARD H. MADDOX.....Republican																																						
 <input type="checkbox"/>	JAMES A. McQUADE.....Democratic																																						
 <input type="checkbox"/>	IDA CROUCH HAZLETT.....Socialist																																						
 <input type="checkbox"/>	CHRIS RILEY.....Farmer-Labor																																						
 <input type="checkbox"/>	EDWARD M. WARING.....Prohibition																																						
 <input type="checkbox"/>	FRED J. DEVERALL.....Single Tax																																						
<p>6</p> <p>COUNTY JUDGES.</p> <p>Vote for three!</p> <table border="1" style="width: 100%; border-collapse: collapse;"> <tr> <td style="width: 20%; text-align: center;"> <input type="checkbox"/> </td> <td style="width: 80%;"> WILLIAM R. BAYES.....Republican </td> </tr> <tr> <td style="text-align: center;"> <input type="checkbox"/> </td> <td style="text-align: center;"> ALMETH W. HOFFE.....Republican </td> </tr> </table>	 <input type="checkbox"/>	WILLIAM R. BAYES.....Republican	 <input type="checkbox"/>	ALMETH W. HOFFE.....Republican	<p>9</p> <p>PRESIDENT OF THE BOROUGH OF BROOKLYN.</p> <p>Vote for one!</p> <table border="1" style="width: 100%; border-collapse: collapse;"> <tr> <td style="width: 20%; text-align: center;"> <input type="checkbox"/> </td> <td style="width: 80%;"> GEORGE W. BAKER.....Republican </td> </tr> <tr> <td style="text-align: center;"> <input type="checkbox"/> </td> <td style="text-align: center;"> EDWARD RICE.....D </td> </tr> </table>	 <input type="checkbox"/>	GEORGE W. BAKER.....Republican	 <input type="checkbox"/>	EDWARD RICE.....D																														
 <input type="checkbox"/>	WILLIAM R. BAYES.....Republican																																						
 <input type="checkbox"/>	ALMETH W. HOFFE.....Republican																																						
 <input type="checkbox"/>	GEORGE W. BAKER.....Republican																																						
 <input type="checkbox"/>	EDWARD RICE.....D																																						

main ways of arranging the names of the candidates and the positions for which they are running. One of the most popular forms, commonly called *The Massachusetts Ballot*, is arranged according to the offices for which the candidates are running. In other words, the names of all candidates for governor are placed one after the other, either in alphabetical order, or in the order in which they are drawn for position. Beginning with the highest office, each group of candidates is then arranged in the order of its importance.

The voter, in making a choice, must first look for the office, such as Governor, Lieutenant-Governor, Comptroller, Mayor, or Alderman; then read the names under each position in order to find out the candidate for whom he desires to cast his vote. This method must be followed for all the positions to be filled, and an "X" must be marked at the side of each name voted for.

A Split Ticket

A ballot of this character is a very difficult matter for the uneducated voter to use successfully. Such a voter has great difficulty in voting a straight ticket, that is for all the Republican, or all the Democratic, or all the Socialist candidates, as he has to hunt among a great many names to find the right party candidates. For the intelligent voter such a ballot makes it easy to vote a *split ticket*; that is, to vote, let us say, for a Republican Governor, a Democratic Lieutenant-Governor, and an Independent Mayor.

A modified official MASSACHUSETTS BALLOT is here shown. In New York State the party emblem is printed opposite the name of the candidate. For the intelligent voter, this makes it easier to vote a split ticket; that is, to vote, let us say, for a Republican Governor, a Democratic Lieutenant-Governor, and an Independent or Socialist Mayor. This ballot, however, makes it hard for a voter to vote a straight ticket, that is, for all the candidates of one party, as he has to hunt among a great many names to find the right party candidates. This form of ballot is generally used in local elections.

Illustration of Ballots

Another ballot, possibly more popular than the Massachusetts Ballot, is what may be called the *Party Column Ballot*. This ballot is used in a great many states. It is arranged according to party; that is, the columns of names run down the ballot, each separate column containing the names of the candidates of a particular party. At the top of each column is the party emblem with a circle underneath. The voter may vote in one of two ways. He may cast a *straight ballot* by making an "X" in the circle, or he may *split his ticket* by marking an "X" at the side of the name of each official for whom he wishes to vote.













This form of ballot is the best for a person who wishes to vote a straight ticket. It is good for the illiterate or uneducated voter. He simply puts his cross in the circle and votes correctly. It is also best for the staunch party voters who wish to vote a straight party ticket.

A third form of ballot now very common is a combination of the two forms just described. The arrangement is the same as that of the Massachusetts Ballot, but each name is preceded by the party emblem so that even an illiterate voter can mark his ballot correctly. In every election many ballots are thrown out because the individual voter has not followed directions. A good ballot is one that reduces this possibility to a minimum.



Becoming a Member of a Party

The voter's task is not completed when he votes on election day. He is extended the privilege of doing his share in the

1. To vote for all the electors of one party make a cross X, mark within the circle above the party column.
2. To vote for some, but not all, of the electors of one party, make a cross X, mark in the square at the left.
3. To vote for some, but not all, of the electors of two or more parties, make a cross X, mark in the square at the left.
4. To vote for some, but not all, of the electors of one party, make a cross X, mark in the square at the left.
5. To vote for some, but not all, of the electors of one party, make a cross X, mark in the square at the left.
6. Any other mark or any cross or line on the ballot renders it void.
7. If you tear, or deface, or wrongly mark this ballot, return it and obtain another.

 DEMOCRATIC PARTY. For President, JAMES M. COX For Vice-President, FRANKLIN D. ROOSEVELT	 IN THE CIRCLE ABOVE THE NAME MAY BE MADE A CROSS X, MARK IN THE SQUARE AT THE LEFT.	PRESIDENTIAL ELECTORS: VERONICA C. GILBERT-SHEVY RICHARD BELMOR, JR. WALTER W. WOODRUFF
 REPUBLICAN PARTY. For President, WARREN G. HARDING For Vice-President, CALVIN COOLIDGE	 IN THE CIRCLE ABOVE THE NAME MAY BE MADE A CROSS X, MARK IN THE SQUARE AT THE LEFT.	PRESIDENTIAL ELECTORS: VERONICA M. HAYDON OTIS B. CUTLER CHARLES A. DAVIES
 SOCIALIST PARTY. For President, EUGENE VICTOR DEBS For Vice-President, SEYMOUR STEEDMAN	 IN THE CIRCLE ABOVE THE NAME MAY BE MADE A CROSS X, MARK IN THE SQUARE AT THE LEFT.	PRESIDENTIAL ELECTORS: JUSTICE W. ALLEN FRED L. ALLARD MORRIS BERMAN WILLIAM COLEMAN
 PROHIBITION PARTY. For President, AARON S. WATKINS For Vice-President, D. LEIGH COLVIN	 IN THE CIRCLE ABOVE THE NAME MAY BE MADE A CROSS X, MARK IN THE SQUARE AT THE LEFT.	PRESIDENTIAL ELECTORS: JUSTICE S. V. CHARLES E. JAY JOHN A. DUNFEL CLARENCE DICKEYSON
 INDEPENDENT NOMINATIONS. SOCIAL LABOR PARTY. For President, WILLIAM W. COX For Vice-President, AUGUST GILLHAUS	 IN THE CIRCLE ABOVE THE NAME MAY BE MADE A CROSS X, MARK IN THE SQUARE AT THE LEFT.	PRESIDENTIAL ELECTORS: HENRY BURNS ANDREW PETERSON E. A. JACKIE
 INDEPENDENT NOMINATIONS. FARMER-LABOR PARTY. For President, HARLEY P. CHRISTENSEN For Vice-President, MAY S. HAYES	 IN THE CIRCLE ABOVE THE NAME MAY BE MADE A CROSS X, MARK IN THE SQUARE AT THE LEFT.	PRESIDENTIAL ELECTORS: JOSEPH L. DYER WILLIAM BUCKNER
BLANK COLUMN. IN THE COLUMN ABOVE THE VOTER MAY WRITE THE NAME OF ANY PARTY OR CANDIDATE HE DESIRES TO VOTE WITHOUT MAKING IT NOT PRINTED ON THE BALLOT.		PRESIDENTIAL ELECTORS

A PARTY COLUMN BALLOT, which is here shown, is an ideal ballot for the staunch party man. All the candidates for a certain party are run under the party emblem. To vote a straight party ticket all the voter has to do is to mark an "X" in the circle under the party emblem. This form of ballot is not so easy for those voters who wish to vote a split ticket. This is the form of ballot that is used throughout the whole country for Presidential Elections. In these elections, tickets are not split by the voters to the extent that they are in local elections. Most voters usually want to see the party win, and hence vote a straight party ticket. . . . For many reasons it is desirable that a voter become a member of a political party and even become a worker in it.

ASSOCIATE JUDGE OF THE COURT		1
Vote for one! OF APPEALS.		
	<input type="checkbox"/>	WILLIAM S. ANDREWS.....Republican
	<input checked="" type="checkbox"/>	TOWNSEND SCUDDER.....Democratic
	<input type="checkbox"/>	HEZEKIAH D. WILCOX.....Socialist
(Empty row)		

The voter must take care to see that he marks all sections of his ballot properly, otherwise it will be thrown out. The first illustration shows A CORRECTLY MARKED BALLOT. The "X" is in the







running of a political party. Many voters neglect this duty. There is little use in criticising party government, or regretting the fact that there is little difference between candidates except in the degrees of their dishonesty, if we fail to do our share in party government. However, to become a party member a citizen must meet certain tests. In some states the test of party affiliation used to be left to the decision of the party managers who were given the power to make up the list of eligible party voters. Such a method, of course, gives the *central organization committee* control over the party organization.

Party membership in most states is now regulated by law. In some states a simple declaration to the effect that you belong to a party is enough. In others the act of voting at a primary is all that is necessary to make you a member of a party. In others, again, the voter is required to give his party affiliation when he registers at the primaries, and from this record the lists of the enrolled party voters are made.









Open and Closed Primary

There are two kinds of primaries; the *Closed* and the *Open*. In the closed primary the voter must declare to which party he belongs and vote only the ticket of the party. In the open primary he has the privilege of voting in secret for which ever party he chooses.

As a legally recognized member of a party, the individual may vote in the party primaries for the candidates who are running for office, and at the same time he may vote for those repre-

Vote for one!		MAYOR.	2
	<input type="checkbox"/>	HENRY H. CURRAN.....Republican	
	<input checked="" type="checkbox"/>	JOHN F. HYLAN.....Democratic	
	<input type="checkbox"/>	JACOB PANKEN.....Socialist	
	<input type="checkbox"/>	JEROME T. DE HUNT.....Farmer-Labor	
	<input type="checkbox"/>	GEORGE K. HINDS.....Prohibition	
	<input type="checkbox"/>	JOHN P. QUINN.....Social Labor	
	<input type="checkbox"/>	JOSEPH DANA MILLER.....Single Tax	
(Empty row)			

proper place—in the square opposite the party emblem. THE NEXT BALLOT WOULD BE THROWN OUT. The 'X' is not in the proper place and voids the entire ballot for ALL offices. The third ballot

Vote for one!		COMPROLLER.	3
	<input checked="" type="checkbox"/>	CHARLES C. LOCKWOOD....Republican	
	<input checked="" type="checkbox"/>	CHARLES L. CRAIG.....Democratic	
	<input type="checkbox"/>	HARRIOT STANTON BLATCH...Socialist	
	<input type="checkbox"/>	BEN HOWE.....Farmer-Labor	
	<input type="checkbox"/>	JOHN McKEE.....Prohibition	
	<input type="checkbox"/>	E. A. ARCHER.....Social Labor	
	<input type="checkbox"/>	EDWARD LINDGREN.....Workers' League	
	<input type="checkbox"/>	GEORGE R. MACEY.....Single Tax	
(Empty row)			

IS MARKED INCORRECTLY, for the voter has voted for TWO candidates when he should have voted for just ONE and the officials are compelled to void this ballot for office of Comptroller ONLY.

representatives of the party who carry on the party organization. These are very important duties, although they are not generally so considered by the average voter. Your *county committeeman*, for example, is often elected by a very few voters. He is, however, an official of consequence, being concerned very largely with the building of party organization policies.





Intelligent Voters

Although good government depends upon a large group of active and intelligent voters, one of the great difficulties in all democratic countries is the task of keeping the voter on the job. Generally the interest at a Presidential Election is great enough to bring out a record vote, possibly as much as seventy-five to ninety or even ninety-five per cent of all the voters; but in local elections interest often lessens so that the percentage of votes cast runs from fifty to as low as ten per cent of the possible voters. Yet these local officials are of the first importance for they decide matters which touch our daily lives.







Lack of interest, especially in local elections, tends to throw a party into the hands of *machine men*, and is one of the main causes of corrupt boss rule. A lack of interest on the part of the mass of voters in a democratic country is unfortunate, since democracy must depend upon its voters.

Compulsory Voting



Many remedies have been suggested to bring the voters out on election day. In a few nations voting has been made compulsory. In Belgium and Spain the

JUSTICES OF THE SUPREME COURT FOR THE SECOND JUDICIAL DISTRICT. 5		
Vote for two!		
		HARRY E. LEWIS.....Republican
	X	FRANK S. GANNON, Jr.....Republican
	X	MITCHELL MAY.....Democratic
	X	WILLIAM F. HAGARTY.....Democratic
		JOSEPH A. WHITEHORN.....Socialist

A like mistake has been made in this ballot. The voter has VOTED FOR THREE CANDIDATES when only TWO are allowed. Thus this ballot for Justices of the Supreme Court is made void. The fifth

PRESIDENT OF THE BOROUGH OF QUEENS. 8		
Vote for one!		
		EDGAR F. HAZLETON.....Republican
	X	MAURICE E. CONNOLLY.....Democratic
	X	BARNET WOLFF.....Socialist
		HERMAN DEFREM.....Farmer-Labor
		JOHN W. MOORE.....Prohibition
		FRED HESSE.....5-Cent Fare

ballot would not be counted because THE "X" IS ON THE LINE instead of in the square. A voter is permitted to vote for parties not on the ballot. He

COUNTY JUDGE. 6		
Vote for one!		
		HENRY G. WENZEL, Jr.....Republican
		BURT JAY HUMPHREY.....Democratic
		LOUIS ROEPER.....Socialist
		<i>Alfred E. Smith</i>

can do this by WRITING IN THE NAME OF HIS CANDIDATE in space left for this purpose. Note that where two or three votes are to be cast on any one ballot, a corresponding number of blanks are left to fill in names. A voter who uses anything but a crayon PENCIL WITH BLACK LEAD in marking his ballot will not have his vote counted.

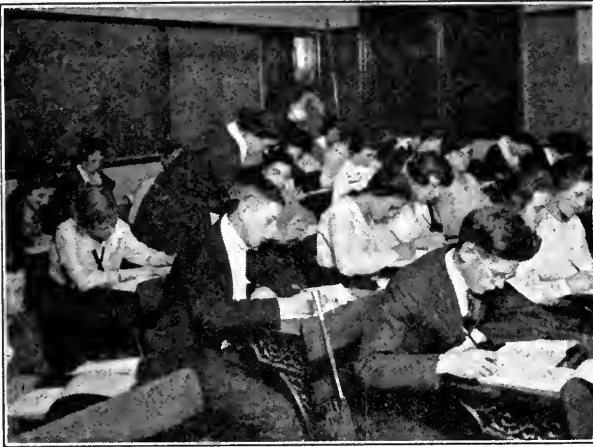

America, through the government of the states and municipalities, and the encouragement of the National Government, aims to meet the educational needs of all its citizens. The school system extends from the Kindergarten through THE ELEMENTARY SCHOOL, High School, Normal School, and Municipal

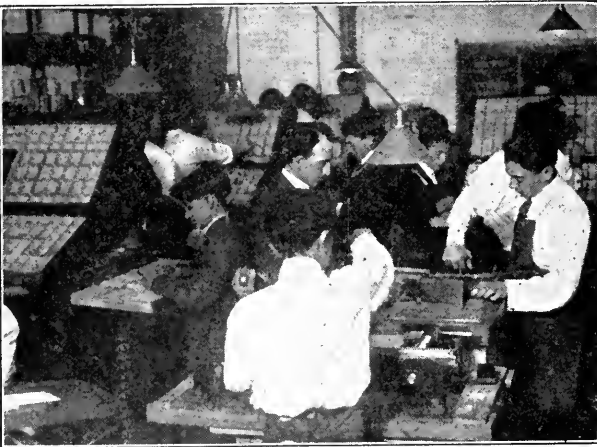

and State University. To better meet the needs of the times, encouragement is being given to the development of Junior High Schools and DAY AND EVENING VOCATIONAL OR TRADE SCHOOLS,



and to the introduction or development of courses in instruction for the foreign born, especially in AMERICAN CITIZENSHIP.

individual who neglects to vote is fined or has his taxes increased, or, if the offense is repeated, he loses his political rights. Some people urge passing such a law in the United States. Such a plan, however, has never received popular approval in this country, and it is doubtful if it could be made generally effective.

When a democracy has to compel its voters to go to the polls, something is radically wrong. Would an unwilling voter cast his vote either intelligently or loyally? Only an intelligent, active, enthusiastic citizenship, voting without compulsion, can make an efficient democracy. *A burning desire to vote on the part of each voter is the first essential of good government.*

Education

Democracy depends upon a great group of voters, an electorate, who are educated to the needs of government. Thorough education must go hand in hand with the vote. In the United States, giving the vote to all men and women over twenty-one years of age carries with it many problems for American democracy. *A democracy where the rank and file of voters are ignorant and prejudiced will fail.*

Some students of politics claim that a democracy cannot be successful where *twenty-five per cent. of the voters are illiterate.* America depends upon an educated body of citizens who can understand the many proposals made to them; who can see the mistakes which often lie back of many glittering schemes that fool the ignorant. In a democratic state nothing pays so

well as education. *All citizens should give their entire support to the upbuilding of the best possible school system, and should never, through false economy, be led to support any policy which will break down the educational progress of the nation.*

The Supreme Task

The schools are the bulwark of this Democracy. Upon their foundation is placed the responsibility of training future American citizens. The leaders of our educational forces realize this fact. They are placing more and more emphasis on citizenship training. Civics in many states is a required course of study in the schools. Special citizenship teachers are being trained; evening schools are rapidly increasing in number, and on every hand is found a renewed interest in this supreme task of the public schools,—the training of American citizens.

For this reason, America spends on its schools more money than on any other part of its governmental activities. These schools, paid for by the taxes of all the people, serve this great nation by training men, women and children to appreciate their privileges and to carry their obligations as citizens.

Evening Schools

In many cases, girls and boys are forced to leave school at the end of their elementary school training. For these, and for the adults who have never had an opportunity to secure an education, evening schools are provided. Splendid public libraries, second in importance only to the schools, also give facilities for free information and education. In America the advantages of learning are not limited to any age or to any sex. Any man, woman, or child will find some school to meet his or her particular need. No nation in the world has provided its citizens with more educational opportunities than are to be found in the United States.

Character Training

More important even than technical book education is a training in character, in will. Most republics that have failed owe their failures to lack of self-control on the part of the citizens. A group of men, for example, that finds itself in a minority after an election, and is unwilling to accept the decision of the majority, starts a revolution to seize the offices. Such methods will in time destroy a democracy. *Only people of self-controlled will can make a success of self-government. Democracy is self-government.*

Another item of equal importance is that the individual citizen must unselfishly consider the welfare of the community as a whole. It has already been noted that taxpayers are often unwilling to bear the proper burdens of taxation. This usually happens because people do not realize how much they owe to the government, or that government is all of us organized. The proper attitude, however, is that of the good neighbor, the man who wishes to see the community as a whole prosperous. When citizens possess sufficient knowledge, self-control, and devotion to the welfare of the majority, their government is sure to be successful.

The vote is the greatest gift of the State to its political children. The citizen who is granted this privilege should seek to merit it by securing all the information possible that will give him a better understanding of government. It is even more important that the citizens, as has been stated, train themselves in self-control and unselfishness. Especially is this true in the United States where government by the people prevails. If our government is to succeed all citizens must be trained for self-government. In the words of the noted economist, John Stuart Mill: "Universal teaching must go hand in hand with universal voting."

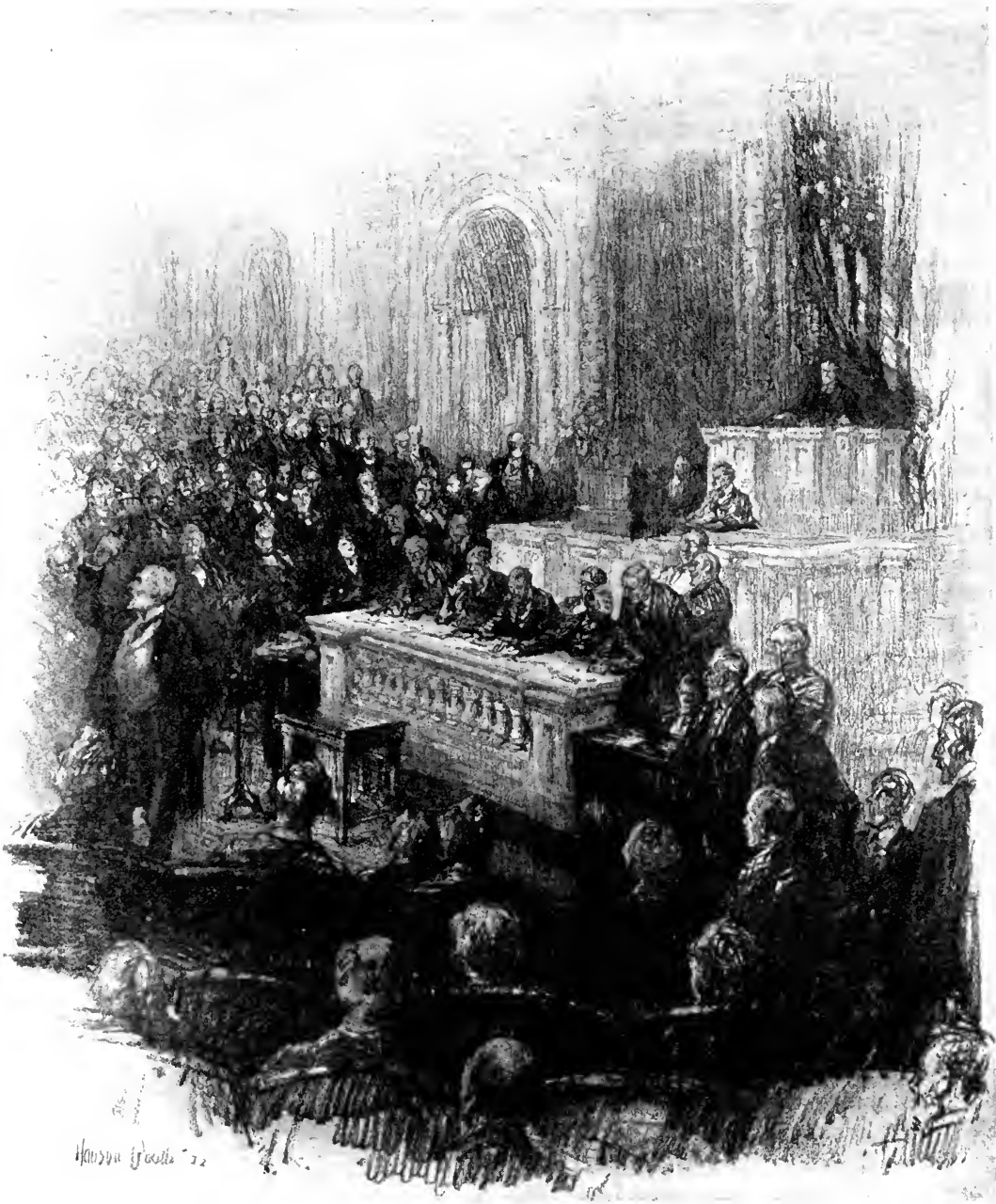

©The American Viewpoint Society

Drawing by Hanson Booth

OUR REPRESENTATIVES IN CONGRESS

One reason why the United States is such a stable, strong and sound country is this:
It has a Representative Government

Our Representatives in Government

A Man Chosen by Others to Act as Their Representative Should Be a Free Agent

THE UNITED STATES is a young nation. We seldom stop to consider, however, that it is the oldest popular government now existing in the world, and that according to some authorities it is the strongest democracy and the one least inclined to change its ways.

Proof of the first of these statements can be found in history. For proof of

the other two we must examine the organization of the government of the United States which makes it difficult to pass new laws quickly unless unusual circumstances, such as war, demand them.

Government action is too slow, we are told. Yet when we see the trouble that comes to impatient nations we must ask ourselves this question: Were not the founders of our country wise when they so framed the Constitution as to make

our government take stock before passing an important piece of legislation?

Of people who act rashly we always say: "Well, you can expect nothing good from them, they are always in hot water!" If plain Mr. Homestead and Miss Flora Loveland elope an hour after being introduced at a suburban dance, all the neighbors murmur: "Marry in haste, repent at leisure." But if Senator Homestead and Senator Flora Loveland, along with other senators, fail to put a bill

through promptly after it has been introduced, the voters grumble and exclaim: "H-m-m! They're slower than molasses in winter time!"

There is too much at stake for a government to act hastily. The Prohibition Amendment is an example of the difficulties in making a law that pleases everyone. Although it was discussed for

many years before it became law, and was passed as the Constitution decrees amendments should be passed, there are still many people who think it unfair and unjust.

A large majority of the population should be in favor of laws of this character before they are put into law, otherwise public sentiment will not be strong enough to enforce them.

Real progress in government is made step by step; it does not come in a hurry. Laws formed as the

result of hasty action are likely to do more harm than good. The difficult problems of democratic government demand the earnest thought of *all* citizens.

Difficulties of Detecting Errors

It is often difficult in government to know or to discover what is wrong. Often what appears an evil is not wrong. Again, after one discovers the evil it is still difficult to suggest a remedy.

The True Basis

THE United States is made up of great cities, of farms, of ranches, of the orange groves of California, of the mills of New England, of the cotton fields of the South and of the wheat fields of the West . . . Representatives coming from all parts of the country bring together the public opinion of the Nation. On the basis of that public opinion legislation is passed.



After the World War there was a great public clamor for lower prices. In 1919, the President called a GREAT CONFERENCE OF LABOR AND BUSINESS MEN to Washington to see if a way could not be found to reduce prices. But the task of reducing



prices was very great. This task was made harder because a period of unemployment set in. People without work could not buy. Prices, under such conditions, naturally came down of themselves but not in a way that pleased the public or our representatives in Washington. Even if goods are sold at lower prices it hardly can interest THE MAN OUT OF A JOB, or the farmer who, perhaps, receives so little



for his crop that it does not PAY HIM TO HARVEST IT.

Every citizen knows that shortly after the World War there was a great public demand for lower prices. Politicians especially were demanding that the high cost of living and high prices should come down. The word "*profiteer*" was on everybody's lips. Often the average citizen seemed to think that a *profiteer* was *everyone else but himself*. Few stopped to consider that in periods of high prices work is plentiful, everyone is earning good wages, and there is little real suffering. But when prices come down many find that work is scarce and wages and profits less.

Government Must Take Time

There is no use telling a man who is out of work that he may buy a shirt today for one dollar and fifty cents which cost three dollars a year ago. Nor would it be wise to praise low prices in the presence of a western farmer who perhaps receives so little for his crop that it hardly pays him to harvest it. The question of high or low prices is one of those just mentioned as being hard to solve.

Which is the better? What is the remedy when prices are high? What is to be done when prices are low? Would there have been a bad panic in the United States after the late war if prices had not come down? Now that they are down, how are we to relieve the suffering that the low prices have brought? No one knows. We see then how difficult it is for a government to act wisely and justly toward all its people. *It must take time to think* before it acts if it is to be strong and wise.

Representative Government

One reason why the United States is such a stable, strong and sound country is this: It has a *representative government*. A representative government is one in which the people choose certain of their number to act for them upon public questions. It is carried on by individuals elected by the voters who could not possibly take time away from the business of making their living to study the relative merits of all the complex governmental problems that arise.

Representative government in America was first established in Virginia in 1619. Every one of the *Thirteen Original Colonies* which later formed the United States had representative assemblies, elected by the voters, which had the power to legislate and the power to tax.

Legislation in a Small Town

In Massachusetts and other New England States town meetings called together all the citizens of all the towns at certain stated times of the year and passed laws. The people attended these meetings in person, and by personal voting expressed their approval or disapproval on town questions. For small groups this was an excellent way of doing business. Even today this method of legislating is carried on in New England towns, in New York rural districts, in Michigan and elsewhere. The townspeople make their own laws, elect their own officials, make their own appropriations for local improvements, and provide for the raising of their own taxes.

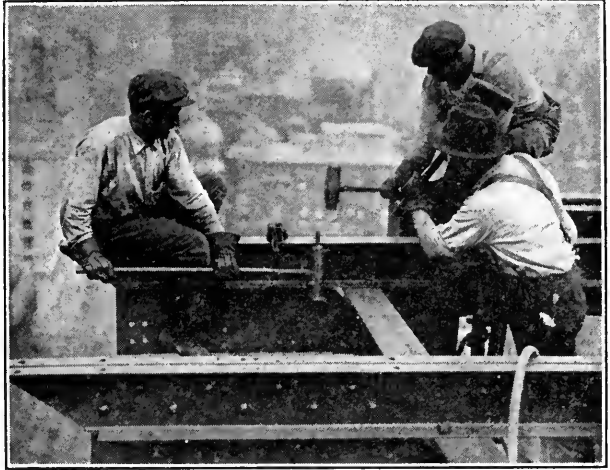

In the early months of 1922, prices were down, but many were out of work. Few were satisfied. So, it will be seen that the work of our Representatives is most difficult at times. Upon their shoulders rest many complex problems. The reduction of prices and unemployment are but two of the problems that they are called upon to solve. **WE, OURSELVES, ARE TOO BUSY** to give the necessary time to the

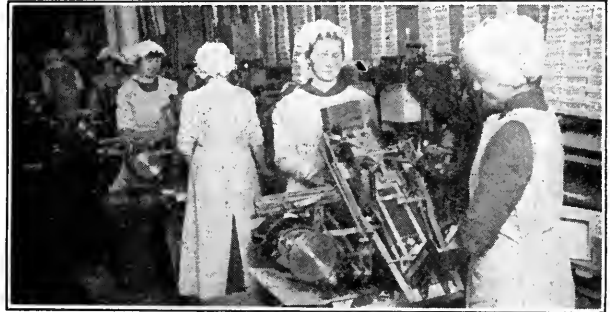

careful study that these and many other questions demand. **WE HAVE OUR WORK TO DO** in shop, office, factory or farm. Long ago, when there were fewer people in the country and men took more time

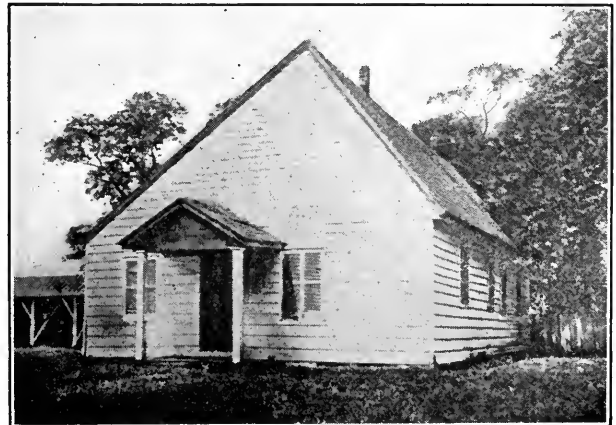

to attend to public matters, all the voters used to gather in **MEETING HOUSES**—the one illustrated is typical—and there discuss public questions.

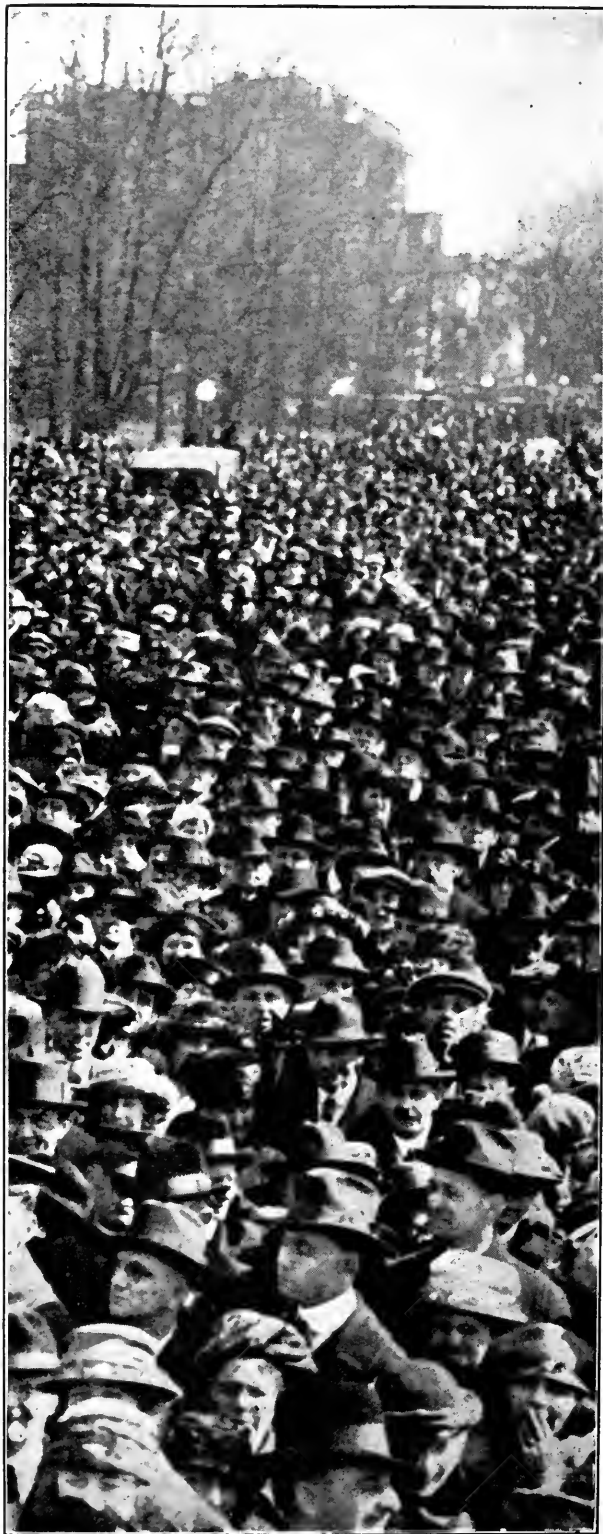

PART OF THE GREAT CROWD at President Harding's Inauguration, March 4, 1920. How could each of these be heard in a town meeting?

For large groups such a method is found difficult. Just as soon as the towns grow into cities the plan weakens; and when states composed of millions of people try the method, it fails altogether. What would happen if it were attempted by the National Government, itself!

In small towns all the citizens can get together in one single large room or hall and debate town politics. They can meet, for example, to discuss whether or not they wish to have a new high school, and where that high school should be located. *But where can all the people of a state get together?* And how can the average voter, without much time for study, solve the complex problems of state and nation?

Complex Problems

The tariff, the control of the railroads, the organization of the Federal Reserve Bank, the making of a treaty, the drafting of a franchise for a city street railway, unemployment, are questions which require knowledge, training and long study by people who give their whole time to such subjects. Can we, as voters, do better than to elect to office honest, well-qualified men and women who will deal wisely for us with these and other great questions? Former President Wilson has stated: "*A people who know their own minds and can get real representatives to express them are a self-governed people.*"

Good government is not so much a question as to which is more democratic, direct or representative legislation, but, rather, which gives the better results,

As American Government is run today, *the main responsibility of the voter is to elect upright and wise representatives who will act for him.* The ultimate and the final power of government in the United States is in the hands of the people, but to a very great extent, and necessarily so, the people must express this power and rule through chosen agents.

Representatives or Delegates

In a representative democracy the voters pick out a small group of men who will act for the many. A man chosen to act for others, to be a representative, should be a free agent. In other words, he has the right to act as he thinks best in a given situation. He should be subjected to no direct compulsion.

For example, if he is elected to Congress he must bear in mind *that it is his duty to act for the good of the whole nation, and not alone for the good of the district from which he comes.* At times he may have to go against the views held by the majority in his district. Some people feel, however, that a representative must be a *delegate*; that he must always vote as his particular district dictates; that he is its mouthpiece or sounding board.

The distinction between a delegate and a representative is very important. If representatives are to be looked upon as mere mouthpieces, it is very doubtful whether we shall secure big and outstanding men for our legislators. On the other hand, if we keep in mind the idea that our legislators are our representatives we shall probably secure men who think independently and who are willing to take the

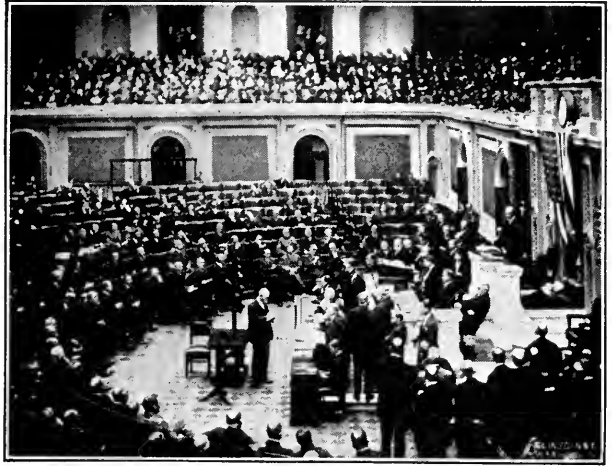

With a population of 105,710,620, living in 2,974,000 square miles of territory, it would be impossible to call together the people of even one big city. So **WE ELECT REPRESENTATIVES WHO LEGISLATE FOR US.** Our legislators must take an oath to up-



hold the Constitution and our laws. Every representative, from the President of the United States down to the humblest public official, **MUST TAKE SUCH AN OATH** upon taking office. The illustration shows William McKinley the twenty-fifth President of the United States, taking the oath of office.

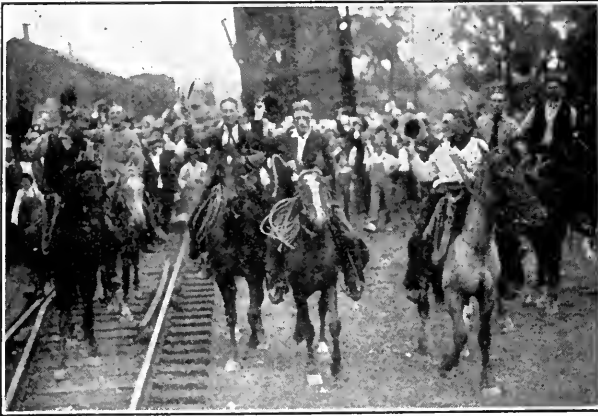

Surely Representatives can do the work of making laws better than we could do it ourselves. They give all their time to the work; they are in company with people from all parts of the country; they are in constant touch with experts in every walk of life. The President, or a candidate for the Presidency, meets citizens in all parts of the country. He meets **THE PEOPLE OF THE FAR WEST.** He



talks to the men and women **OF OUR GREAT CITIES.** He discusses the questions of the day with men



and women who live on **THE GREAT FARMS AND RANCHES.** The same is true of our representatives. We have neither time nor opportunity to get their point of view. But our President and our other representatives have.

responsibilities of furthering, as best they can, their country's welfare. Representatives have, also, better opportunities to study and understand public questions in all their bearings than their constituents can possibly have. The delegate idea, however, favors the demagogue, the man who is willing to promise to do anything or everything that his district desires.

Value of the Representative

Individuals constantly living among people who think as they do are apt to become narrow-minded. We should keep in mind the fact that a legislature represents, in the case of a city, *all sections of the city*, in the case of a state, *all sections of that state*, and in the case of Congress, *all sections of the United States*. Representatives, meeting as they do representatives from all sections of the city, the state, or the nation, are best qualified to legislate for the common good. A wide difference of social and economic conditions in the United States, makes it very difficult to tell what the opinion of the whole country is on any particular issue. The legislator, the representative, is probably more nearly correct in his judgment of what the people want than are the voters.

One of the great benefits of a Presidential election is gained from the fact that the candidates often visit all parts of the country during the campaign. The knowledge thus gained helps the successful candidate to fill better the high office of President of the *whole* country.

A man in Chicago, for example, may not realize that nearly one-

half of the population of the United States is living in rural districts. A man living in a small town, or on a ranch in the far west, does not realize what six million people look like in the city of New York. The United States is made up of great cities, of farms, of ranches, of mines, of the orange groves of California, of the mills of New England, of the cotton fields of the South, and the wheat fields of the West.

All these go into the making of the American Nation, which is organized in such a way that representatives coming from all parts of the country, representing all the different economic and social interests of all the states, bring together the public opinion of the nation. On the basis of that public opinion legislation is passed.

A Word of Caution

A word of caution should be given here. One often gets the idea from some of our newspapers and at times from speakers, that most representatives in government are in office solely for their own good or for selfish reasons. In some cases this is no doubt true, but it is not usually the case. Many examples might be given of men who have sacrificed career and fortune to serve the people. We are very quick, often too quick, to say that public servants are self-seeking.

Government Reform

Many people today demand that our government move more quickly. They are not content with slow but sure progress. They feel that representative government does not carry out the wishes of the people; that



Our legislators in Congress who come from all the States meet together in Washington and there exchange views. **COMMITTEES IN CONGRESS** that are created to study questions for the purpose of future legislation are made up of public representa-

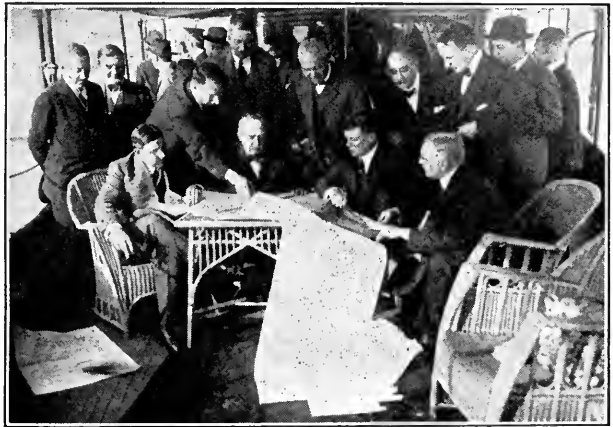

tives from the North, South, East and West. In addition, **THESE COMMITTEES** have power to get



expert advice touching upon such questions as **UNEMPLOYMENT, NAVIGATION, LABOR, FINANCE**—every public question, in fact. The names of some of these committees are: Agriculture and Forestry, Appropriations, Banking and Currency, Civil Service, Commerce, Education and Labor, Finance, Foreign Relations, Immigration, Ways and Means, Appropriations, Pensions and Naval Affairs. There are about twenty chief committees of the U. S. Senate, and about the same number in the House.

INSTRUCTIONS

THIS BALLOT MUST BE MARKED WITH A PENCIL, HAVING CARE TO LEAVE THE SPACES FOR THE CANDIDATE'S NAME CLEAR. THE BALLOT MUST BE MARKED WITH A CROSS OR X IN THE SPACES AT THE LEFT OF THE NAME TO BE VOTED FOR. THE BALLOT MUST BE MARKED WITH A CROSS OR X IN THE SPACES AT THE LEFT OF THE NAME TO BE VOTED FOR. THE BALLOT MUST BE MARKED WITH A CROSS OR X IN THE SPACES AT THE LEFT OF THE NAME TO BE VOTED FOR.

Official Ballot for the Primary Election of the
Republican Party,
 CITY OF SCHECTADY, COUNTY OF SCHECTADY,
 SEPTEMBER 12, 1921



FIRST ASSEMBLY DISTRICT,
 EIGHTH WARD,
 FOURTH ELECTION DISTRICT.

<p>LABELLED FOR THE REGISTER FOR PUBLIC OFFICE</p> <p>MEMBER OF ASSEMBLY (NAME TO BE PRINTED)</p> <p>1 CHARLES H. MALES</p> <p>COUNTY CLERK (NAME TO BE PRINTED)</p> <p>2 GEORGE T. BRADY</p> <p>COUNTY TREASURER (NAME TO BE PRINTED)</p> <p>3 WILLIAM H. WALKER</p> <p>COMMISSIONER (NAME TO BE PRINTED)</p> <p>4 WILLIAM C. TUCKER</p> <p>NOTARY PUBLIC (NAME TO BE PRINTED)</p> <p>5 LEON O. GIBBLE</p> <p>PRESIDENT OF THE COMMONS DIVISION (NAME TO BE PRINTED)</p> <p>6 CLARENCE A. MURPHY</p> <p>COMPTROLLER (NAME TO BE PRINTED)</p> <p>7 WILLIAM A. WICK</p> <p>CITY CLERK (NAME TO BE PRINTED)</p> <p>8 WALTER C. WHITEHEAD</p> <p>ASSISTANT (NAME TO BE PRINTED)</p> <p>9 MARTIN LITZENDORF</p> <p>10 VICTOR W. VAN ROYNE</p> <p>11 LEONARD BROWN</p> <p>12 EDWARD TOWNLEY</p> <p>13 EUGENE C. BARTLEY</p> <p>14 W. P. McWILLIAM</p> <p>ADDRESS (NAME TO BE PRINTED)</p> <p>15 W. H. SINGLES</p> <p>16 WILLIAM L. DODGE</p> <p>DEPUTY CLERK (NAME TO BE PRINTED)</p> <p>17 ERWIN L. ALLER</p> <p>GEORGE H. BLOTT</p>	<p>CANDIDATES FOR THE PARTY POSITION OF COUNTY CLERK</p> <p>MEMBER OF COUNTY COMMISSION (NAME TO BE PRINTED)</p> <p>18 CARL H. SCHWARTZ</p> <p>19 GEORGE H. DUTCHELL</p>	<p>LABELLED FOR THE PARTY POSITION OF DELEGATE</p> <p>DELEGATE TO STATE CONFERENCE (NAME TO BE PRINTED)</p> <p>20 THOMAS G. BUCKNER</p> <p>CHARLES G. TAYLOR</p> <p>GEORGE PARKER</p> <p>21 FRANK CRAMER</p> <p>H. HERBERT WOODCOCK, JR.</p> <p>BARTER L. WOODRUM</p> <p>LELA STALY</p> <p>HYKEL SCHLESFELD</p> <p>ALTERNATE DELEGATE TO STATE CONFERENCE (NAME TO BE PRINTED)</p> <p>ALICE L. BERRYMAN</p> <p>JAMES O. PARKER</p> <p>JOS. H. WINDLEWOOD</p> <p>ELIZABETH WESTMYER</p> <p>22 CHARLES EUGENE</p> <p>W. W. WELLS</p> <p>JAMES A. ROBERT</p> <p>J. HARVEY ORSBORN</p> <p>DELEGATE TO JUDICIAL DISTRICT CONFERENCE (NAME TO BE PRINTED)</p> <p>23 JOHN ALEXANDER</p> <p>24 WALTER B. MOHR</p> <p>WALTER H. FLYNN</p> <p>ALTERNATE DELEGATE TO JUDICIAL DISTRICT CONFERENCE (NAME TO BE PRINTED)</p> <p>WILLIAM S. GILPIN</p>
---	--	---

The chief reforms that are demanded by the people are four, namely: Direct Primaries, Initiative Legislation, Referendum and the Recall. **DIRECT PRIMARIES** seems to be the most important. The method that was used everywhere up to a few years ago was known as the Convention System. A

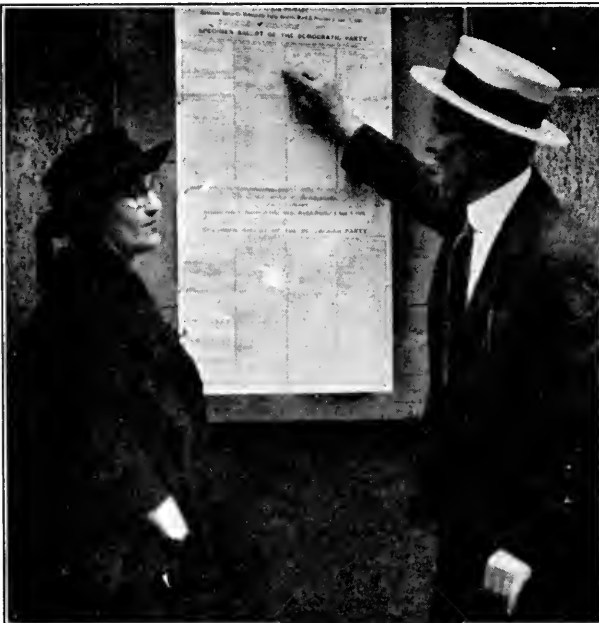

political party holds a Convention. It **MAKES A PARTY SLATE** which includes all the names of the candidates nominated at the convention. These names are printed under the party emblem.

it does not respond to popular demands; that political parties rather than the people dictate the actions of our representatives.

The chief reforms that are demanded to remedy those conditions are four: First, *that the selection of candidates shall be placed in the hands of the voters at what are called "direct primaries."* Second, *that if the people so desire, they may initiate laws by petition and not through representatives, thereby getting what is known as "initiative legislation."* Third, *that if the people desire, a law shall be referred to the voter for final decision. This process is called the "referendum."* Fourth, *that any official who does not meet the demands of the public shall be turned out of office by what is known as the "recall."*

Direct Primaries

Two methods of selecting candidates for office are in use. The first is the method which was used almost everywhere a few years ago—the *convention system*. It operates as follows:

A political party holds a convention of party delegates, chosen at local caucuses, to select people from the party who seem best suited to run for office. People so selected are said to be *nominated* for office by the party in convention. The party officers then publish a list of all the men and women nominated. This list is known as *the party slate* or *ticket*. On the ballot used on election day the party ticket is printed under or over the party emblem. Since other political parties have chosen their candidates in the

same manner and printed their tickets on the ballot sheet, each party ticket is said to be run against the other.

It has been claimed that men nominated in conventions are not the real choice of the people but of a few party managers, or possibly one manager—the boss. To remedy the defects of the convention method a second plan for choosing candidates has been used. It is known as the *direct primary*, and works as follows:

The voters themselves, under the direction of the Government, hold an election, a *primary*, in which it is decided directly what candidates will go on the party ticket. At this election anyone in the party may run for any office. A voter may even nominate himself if he sees fit to do so, even though the party managers and bosses are against him. This method, as has been pointed out, does away with delegates and makes the nominations free to all. It gives each individual voter the chance to select his own candidate. It is a system of choosing candidates now used in many of the states of the United States, though the presidential candidates are still chosen every four years by the convention method.

The Vital Need

No matter which system is used, the direct primary or the convention, the results will always be poor if the people are not alert, intelligent, active and enthusiastic. This is the vital need—an *electorate that is intelligent and on the job.*



It is claimed that men nominated by the convention system are not the choice of the people, but of political bosses. To remedy the defects of the convention method the Direct Primary method is often used. The voters themselves hold an election, a primary, and there decide who shall be candidates. The method of voting in the primary is no different from a regular election. The former Governor of New York State—Mr. Alfred E. Smith—and Mrs. Smith, are here shown VOTING AT A PRIMARY.



A primary campaign is conducted like any political campaign. The vote at a primary is never as large



as the vote at an ordinary election. Presidential candidates are chosen by the CONVENTION SYSTEM.

	YES	NO
<p>ALIEN LAND LAW. Initiative act. Permits acquisition and transfer of real property by aliens eligible to citizenship, to same extent as citizens except as otherwise provided by law; permits other aliens, and companies, associations and corporations in which they hold majority interest, to acquire and transfer real property only as prescribed by treaty, but prohibiting appointment thereof as guardians of estates of minors consisting wholly or partially of real property or shares in such corporations; provides for escheats in certain cases; requires reports of property holdings to facilitate enforcement of act; prescribes penalties and repeals conflicting acts.</p>		
<p>Sufficient qualified electors of the State of California present to the secretary of state this petition and request that a proposed measure, as hereinafter set forth, be submitted to the people of the State of California for their approval or rejection, at the next ensuing general election. The proposed measure is as follows:</p> <p style="text-align: center;">PROPOSED LAW.</p> <p>(Proposed changes from provisions of present laws are printed in black-faced type.)</p> <p>...ing to the rights, powers and disa-</p>	<p>or corporation is inhibited from acquiring, possessing, enjoying or transferring by reason of the provisions of this act. The public administrator of the proper county, or any other competent person of corporation, may be appointed guardian of the estate of a minor citizen whose parents are ineligible to appointment under the provisions of this section.</p> <p>On such notice to the guardian as the court may require, the superior court may remove the guardian of such an estate.</p> <p>(a) That...</p>	

Initiative and Referendum

Other popular reforms have been introduced in many cities and states under the title of the *Initiative and Referendum*. Initiative means simply that the people themselves may propose laws without waiting for their representatives to do so. The method generally used is to circulate a petition among the voters and if ten, or fifteen, or twenty-five per cent—the percentage varies according to the states—of the voters sign the proposed law, it is submitted at the next general election for rejection or adoption, or the legislature is compelled to propose such a law for submission. This method of lawmaking has been introduced into many cities and about one-third of the states.

The *Referendum* is very similar in character to the *Initiative*. A bill is passed by the Legislature, but a number of citizens of the state, or city, feel that the Legislature has made a mistake, that if this bill were submitted to the people, a different decision would be made. In such a case, a petition is circulated asking that the bill be submitted to the vote of the people at an election. As in the case of the initiative, if a certain percentage of the voters, ten, fifteen, or twenty-five per cent, sign this petition, the law is then submitted to the people for a referendum vote. California has the referendum plan.

It is a question open to fair consideration whether the citizen will get better laws by passing upon them himself, or *by giving his best thought upon choosing the right kind of representatives.*

INITIATIVE means that the people themselves may propose laws without waiting for their representatives to do so. **THIS IS SAMPLE OF BALLOT USED IN CALIFORNIA IN 1920**, on which the measures then submitted to the electors were:

CONSTITUTIONAL AMENDMENTS PROPOSED BY LEGISLATURE—Constitutional Convention, State Aid to Institutions, Absent Voters, Alien Poll-Tax.

CONSTITUTIONAL AMENDMENTS PROPOSED BY INITIATIVE PETITIONS—Highway Bonds, Initiative, Land Values Taxation, Prohibiting Compulsory Vaccination, Salaries of Justices, School System.

ACTS OF LEGISLATURE SUBMITTED TO REFERENDUM—Community Property, Insurance Act, Irrigation District Act, Poison Act.

ACTS SUBMITTED BY INITIATIVE PETITION—Alien Land Law, Chiropractic Act, Vivisection.

The Recall

There is another popular reform—the Recall. It has to do with representatives. It is a device whereby a mayor, a judge, a governor, or any other elected officer may be forced out of his position because he has displeased the majority of those voting.

If a number of citizens, say, twenty-five or fifty per cent—the percentage varies according to the states—sign a petition demanding the recall of an official who they feel has not been carrying out his pledges, the official in question must stand for another election. He must go before the people, defend his policies, and ask for a vote of confidence. If the vote goes against him he is removed from office and another person is elected to fill his place. In other words, *the recall is a way for dissatisfied voters to express their disapproval of their official representatives without waiting for the regular election date to come around.*

Much can be said both for and against the recall. There are officials who do wrong, who become grafters, who are not fit for office, who get mixed up with vice. Under such circumstances the well-intentioned voters may use the recall to advantage.

On the other hand there are many officials who do right and are exactly fitted for office, who clean out grafters and remove the vicious, but who do not suit the prejudiced, mean groups of a community. *Under such circumstances the use of the recall may, if the vicious succeed, prove very harmful.*

A Narrow View

Some people fall into the habit of thinking that government is poor and

inefficient because they do not get what they want, or because the government does not do as they think it should. That is natural. They consider their opinions the will of the majority, and are, therefore, suspicious when legislation does not go their way. It is quite possible, however, that their opinions are held by only a small group, and that the representatives are actually preventing minority legislation from being passed when they refuse to carry out certain demands.

Those individuals who have traveled the country from the Pacific to the Atlantic know that opinions held in New York and Boston are not necessarily those held by the voters in the rest of the country on many important questions. Many people in the great immigration centers feel that the restriction of immigration, for example, is unwise, and that the almost unanimous action of Congress in 1921, in cutting down the numbers of people allowed to come into the United States, did not represent the feelings of the people. The action of Congress in this particular case may not meet the wishes of groups in New York or other cities, but it is very likely that when Congress acts almost unanimously it knows what it is doing and is representing, faithfully, the sentiments of the country as a whole. If conditions and public sentiment change, Congress, no doubt, will express itself in new immigration legislation to meet the situation. *Congress seldom passes legislation by an overwhelming vote without being right in its judgment of public opinion.*

“Where Liberty dwells, there is my country.”—*Franklin.*

† † †

“God grants liberty only to those who love it, and are always ready to guard and defend it.”—*Daniel Webster.*



©The American Viewpoint Society

Drawing by Hanson Booth

PUBLIC EDUCATION, A GREAT TASK OF GOVERNMENT

A few years ago these things—libraries and books—were only for the wealthy

Taxes and Government

Taxation is Compulsory Payment for Services Rendered by Local, State or Federal Government

IT IS NOT RIGHT to exempt me from paying an income tax! A citizen should pay to his government a percentage of what he earns, no matter how small that percentage may be. I get a great deal from my government; I should have the satisfaction of paying, in part at least, for what I get." This was a most unusual complaint! It was made by a married man who was exempt from the Federal and New York State Income Tax because he received only fifteen hundred dollars a year!

It is an unusual point of view. Few people have it. Usually the Government is looked upon as a far-away organization, located in Washington, D. C., which is forever taking in taxes the daily bread of the average citizen. Yet, is not *Mr. Fifteen Hundred's* view, as expressed above, the only one that every citizen should have? Good and efficient government is almost as necessary to the individual as food, clothing and shelter. If we would but take the time to examine facts we should quickly discover how absolutely essential good government is to our everyday happiness and welfare; how our very life depends upon the manner in which government is carried on. Why, then, should we cry "Extortion!" and "Robbery!" when we receive a bill in the

form of a tax for these essential services of government? Why, in other words, should we regard taxes as a worse burden than grocery bills?

What We Get From Our Government

The pocketbook, especially when it is taxed, is a touchy spot. On account of the heavy burdens of taxes and living expenses, most people today are criticising their government for spending too much money. The demand that taxes be reduced is general. All about us we hear the charge that the government is inefficient, wasteful and extravagant.

Such statements are apt to be thoughtless. Those who make them at times scarcely realize how, from the cradle to the grave, all of us are dependent upon government for assistance

and protection. But few know that the individual becomes more and more dependent upon his government in proportion as life becomes more complex. If we consider a moment, our minds can recall many vitally important services rendered by government.

The traffic policeman, the soldier and sailor, the judge, the school-teacher, the postman, the lighthouse keeper, the visiting nurse, the health officer, are ever present reminders of the services

Resources Limited

MANY citizens have the idea that the Government has unlimited resources received through taxation. They do not realize that each individual must pay his share of the Government's cost out of his own pocket. . . A good government is careful not to undertake too many new activities which will make necessary burdensome and unwise taxation.

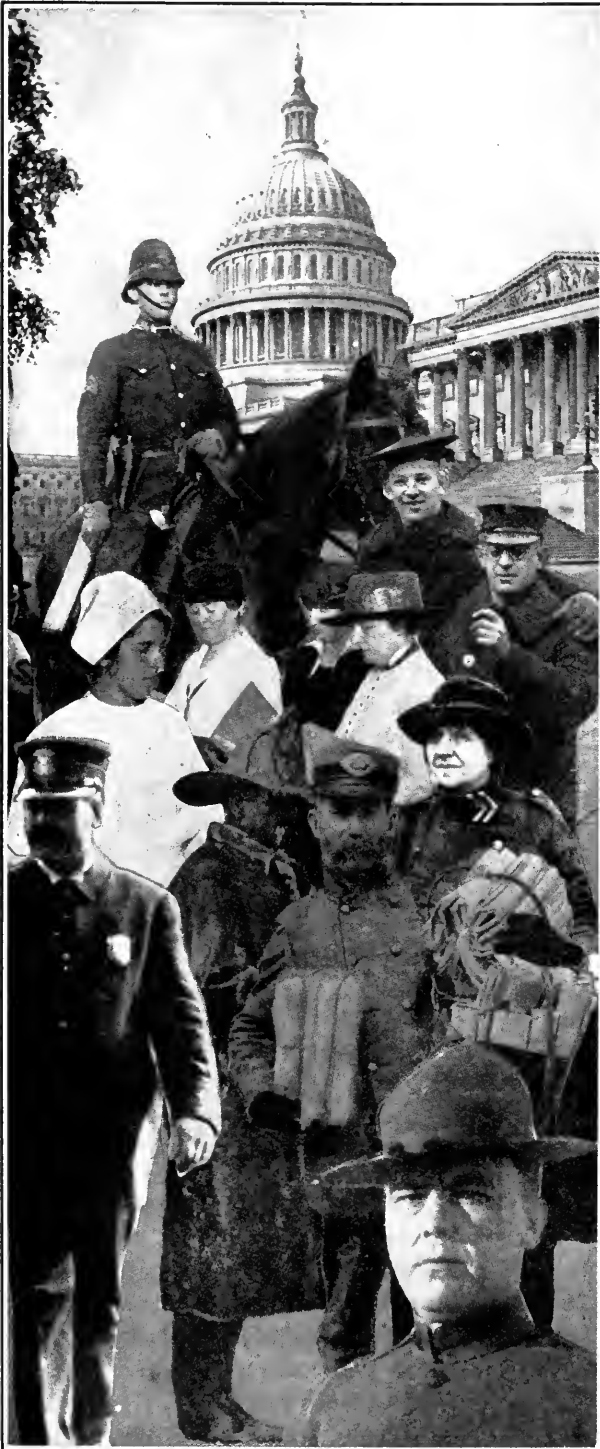

Many object to the amount in taxes that we have to pay for the service that the government gives us. We think government is wasteful. In many ways it is. Yet THESE PUBLIC SERVANTS receive very moderate salaries for the important tasks they perform. They protect us, assist industry, look after the health of the community and educate our children.

which our government renders in return for taxes. These government servants are all a part of our every-day life; they are all busy carrying on that important task of government which is to look after our common needs. *These individuals protect us from danger, make industry possible, look after the health of the community and educate our children.* None are overpaid; most of them receive very moderate salaries, yet all are doing their tasks in an orderly, quiet and efficient manner. The mail is delivered, children are educated, the streets are kept clean, traffic is regulated, and travel by sea is made less dangerous—all by government servants who save us much thought and inconvenience. Their salaries are paid by us in the form of Federal, state and local taxes.

Thoughtless Criticism

We must avoid making careless statements that lump all government services under the head of "wasteful, extravagant and inefficient." It is unwise to criticize taxation before first taking time to learn why the government spends money, and what proportion is spent for the various activities carried on by the government.

The thoughtless "knocking" of the government, indulged in by so many, may do much more harm than good. It may result at times in curtailing or even abolishing many excellent and vital activities, and may harm a great many individuals in the public service who have rendered long and faithful service. On the other hand *intelligent, thoughtful and indepen-*

dent criticism of a helpful nature is absolutely necessary to keep a democracy efficient and responsive to public opinion.

Many of us look upon government solely as a force that restricts. Its main purpose just now, to some, seems centered upon keeping them from getting a drink. Such a viewpoint is very shortsighted. It is true that government as our agent does restrict us, but the restrictions are generally for our own and our neighbor's good, or for the good of society. However, the government also, as our agent, does vastly more than restrict. *It protects us; it assists us in our work; it develops us into better men and women.*

The Tasks of Government

Let us take these tasks in order. First, we find that the foremost, and also the most expensive, is the protection given us by our government against aggression from outside the country, and aggression from dangerous individuals, such as criminals, from within.

War is a stern and disagreeable possibility. Few nations, if any, have ever been exempt from protecting themselves and their citizens at some time in their careers against the attack of some other nation. All government must, therefore, be fore-armed. All nations have had to spend vast sums for defense. It will always be so until nations, acting through their governments, learn to live peaceably together, even while holding different opinions.

Danger From Within

Equally as important to the citizen as the safeguarding of his



The great task of government is to protect us from danger from the outside and from danger from within. It must, for instance, build **STRONG FORTS**. Forts are built to guard coast and boundary lines. Fortunately no forts are needed to guard our long boundary line to the north. Neither has Canada built forts. The

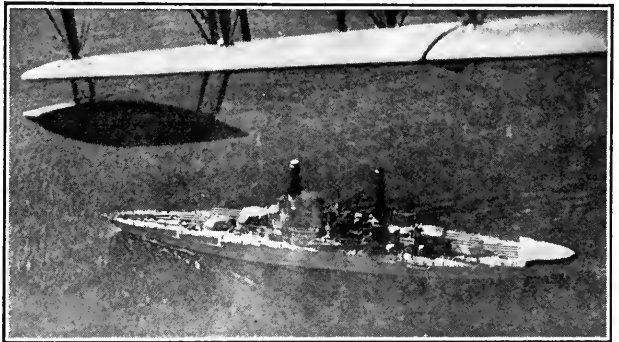

government must build **POWERFUL BATTLESHIPS**, cruisers, destroyers and submarines. It must protect



us with **FLEETS OF AIRPLANES**. In brief, it must maintain at all times for instant service a powerful navy and a well-equipped and trained army. Thus does the government protect us from danger from the outside. All nations so protect their citizens.

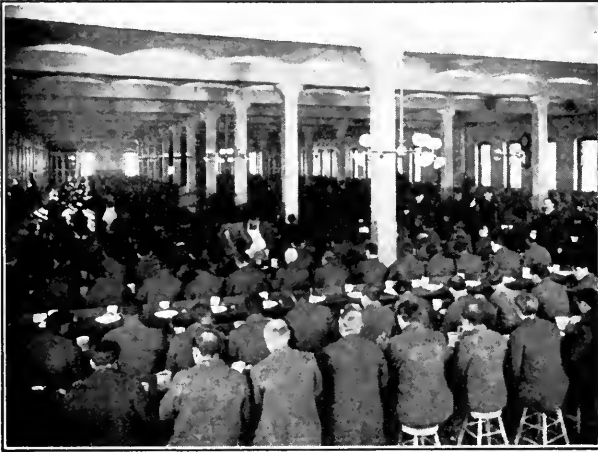

There are dangers from within from which we need the protection of the government. Every government must provide policemen, courts and JAILS for those who have broken the law. These prisoners are at dinner at Sing Sing prison, N. Y. The government



also helps us to make a better living. The POST OFFICE DEPARTMENT carries our letters, checks, money orders and parcels. It safeguards our money in its postal savings banks. The government protects

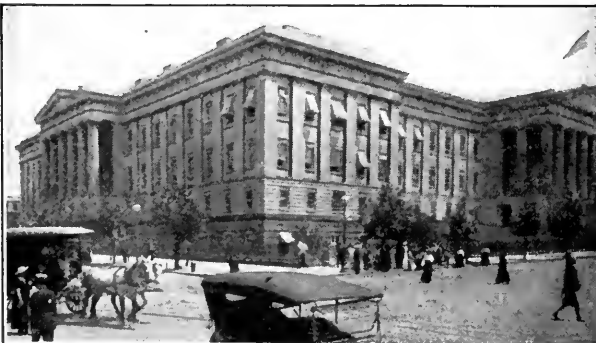

the interests of the author, artist and inventor by granting copyrights and patents. THE U. S. PATENT OFFICE is in Washington. Over 40,000 patents were granted by this office in 1921.

country from attack by other nations, is the government's task of protecting the life, property and reputation of its citizens from danger within. Every government must provide *policemen, courts, jails and firemen.*

A Better Living

The government does much more than protect its citizens. *It assists us to make a better living.* This is the second great task of government. Business can be carried on more effectively. Professional men, such as doctors and teachers, are given opportunity to secure better training through professional schools supported by the state. Working people are helped to become better workmen through trade schools. The government actually assists us to make more money. It conducts many activities which advance us personally, and make for better business conditions. *The United States Post Office*, for example, is a great help to every citizen. The rapidity and certainty with which it delivers the mails is a vital aid to business. Checks, money orders, contracts, must be sent through the mail; and if the postal service were corrupt, or badly managed, business would be greatly hampered. Through the government's guarantee of *copyrights*, writers and publishers of books are protected. An inventor of a new device is also protected by the *Government's Patent Office*, which grants a patent keeping others from using the invention without permission.

The Federal Reserve Board, a great banking institution organized by the United States Gov-

ernment, promotes good business conditions. Through this Board's control of credit, the possibility of a panic, such as the terrible one which occurred in 1893, is greatly lessened. Panics cause the loss of millions of dollars, millions of people are thrown out of work, and thousands of firms and corporations go bankrupt.

Better Men and Women

In addition to assisting citizens in their daily work, the government also *helps them to become wiser men and women*. It wishes its citizens to be well educated so that they may vote intelligently and thus make America a better place to live in.

This is the third great task of the government. Public education, public recreation and public health facilities are provided so that every citizen may have the advantages of knowledge, play and good health. Schools, parks, playgrounds, libraries, museums, zoological gardens and art galleries are free to all, so that each individual, if he has the desire, may avail himself of the accumulated treasures of the world to be found in books, music, sculpture and pictures. A few years ago these things were only for the wealthy. The government now provides them for all of us. One of the great ideals of America is to give all its citizens the opportunity to broaden and deepen their minds.

Government Tasks Greater

The tasks undertaken by the government twenty years ago were much fewer in number than those carried on today. To many individuals the automobile, the electric light and the bathtub



The government not only protects us but it also educates us and provides for our health. There are over 8,000 free PUBLIC LIBRARIES in the United States. The Library of Congress, Washington, has



the largest collection of books in the Western Hemisphere, and third largest in the world. It contains over 2,831,000 printed books and pamphlets. Many cities have art galleries and MUSEUMS for the free entertainment and education of the people. The Smithsonian Institution and the U. S. National Museum, Washington, are free to the public. All this



costs the government a great deal of money. The great CITY OF NEW YORK alone today spends a third as much money as it cost to operate the whole United States Government in 1910.



Our government gives us greater service than it used to give. A few years ago it paid little attention to the health of the children in our public schools. Now, even **THEIR TEETH ARE CAREFULLY EXAMINED**



and instruction is given on how to preserve them. The government also **BUILDS STREETS**, water sys-

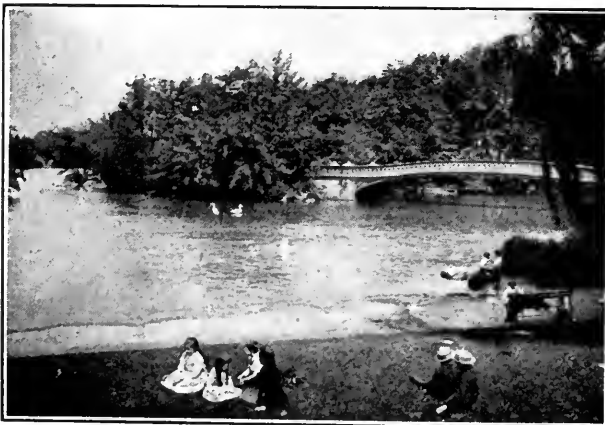

tems and sewers. It plans and maintains **BEAUTIFUL PARKS** and playgrounds. All this service costs money. We often object to the sum the government demands from us to pay for the service that it gives. We object far more if we do not get the service.

have become necessities, while to the government many things formerly considered unnecessary have become necessary. Better education, more recreation, cleaner streets, more parks, well-planned cities are being constantly demanded, and in consequence the cost of maintaining the government is always increasing. *The great city of New York alone, today, spends one-third as much money as it cost to operate the whole United States Government in 1910.*

The more complex life becomes and the more the conscience of the people is aroused, the more government is asked to do. The schools of today, especially in the larger cities, not only train the child's mind in many subjects, but also undertake the improvement of the child's health. Today there is medical inspection of children—especially of their teeth and eyes; and nurses' rooms, elaborate gymnasiums and playgrounds are part of the equipment. Evening classes, free lectures and other forms of adult education are now provided by many states.

Health Departments

Modern medical knowledge regarding typhoid, tuberculosis, measles, diphtheria, yellow fever and smallpox, have brought about a vast increase in the work of *public health departments*. Cities are learning that municipal cleanliness is necessary to combat the spread of disease. The fight against mosquitoes and flies, the constant and careful disposal of garbage, well-constructed sewers, a pure water supply, are modern needs. We know that without them, es-

pecially in our crowded cities, disease would grow to frightful proportions. Only a few years ago, all cities were at times swept by plagues and epidemics.

All these things mean taxes, and more taxes. *But they have added to the average length of human life by more than fifteen years.* Is that not worth while? Even from the financial viewpoint it surely pays well.

War and Taxes

The statement is often heard that *the National Government of the United States is spending seventy-five per cent or more of its income on past and possible future wars.* This is true. It must be remembered, however, that under the American form of government certain powers and duties are given to the Federal Government and among them the most important is that of defending us from the attacks of other nations.

In America, most of the activities which closely touch the citizen's life are looked after by state and local governments, while those that concern the nation as a whole are administered by the National Government. *Possibly half or more than half of our taxes in normal times are for the purposes of state or local governments.* It is for this reason that such a large portion of the money that Congress appropriates goes toward military preparedness.

The *Great World War* called for enormous expenditures which increased the public debt to many times its former figure. During the war, money was spent freely. It is always so. Vast sums are raised.



The sum in taxes that at present we have to pay to the FEDERAL GOVERNMENT alone, is very heavy. This is due to the Great World War. Because of this war it had to spend vast sums. It had to borrow bil-

Meanwhile, YOU Save!

 A black and white illustration of soldiers in a trench during a battle. One soldier is being helped up by another, while others are engaged in combat. The scene is filled with smoke and the sounds of war.

LEND YOUR SAVINGS TO THE GOVT

BUY! W.S.S. BUY!

WAR SAVING STAMPS
A HEALTHY INVESTMENT BY THE
UNITED STATES GOVERNMENT

ions of dollars from its citizens. The Government did this through Liberty and Victory Loans and the sale of WAR SAVING STAMPS (W. S. S.).



We should meet all these war debts cheerfully, ungrudgingly, gladly. The men who **FOUGHT IN THE TRENCHES**, who manned our ships, risked

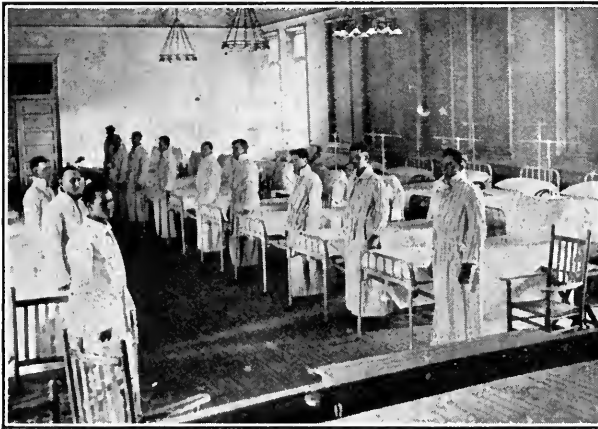

health and life. Today, many of them are **SICK OR CRIPPLED**, and are being nursed back to health and strength in the great U. S. Army Hospitals. Thou-



sands **GAVE THEIR ALL**—their lives. If our taxes are heavier because of the help that the government gives these soldiers and sailors, or their families, what of it! What is the payment of a tax measured against the giving of a life! The cost of the Great World War to the United States was over Fifty-One Billion Dollars. Included in this huge sum are loans of Ten Billion Dollars to our Allies in the war.

Quick results are secured. There is little time for careful thought. For many years to come not only the United States but the whole world will carry a huge burden of taxation. The people must pay these debts out of their earnings. The United States did very great things during the World War. What was done was worth doing; we should not grumble now because we have to pay the bills. As a nation we must pay these war mortgages represented by *Liberty* and *Victory Loan bonds*. These debts and their interest charges are the largest items in the present cost of our National Government. When these debts are cancelled, a great hindrance to national progress will be removed.

Certain other definite war obligations must be paid. We are indebted to the men who paid the price of war—the gassed, the shell-shocked, the wounded, the diseased. It is going to cost us only money—they risked *life and health*. We should care for them cheerfully, ungrudgingly, gladly. *What is a tax measured against a human life?*

Federal Government Activities

The Federal Government does a great many things, however, beside protecting us from enemies. As in the case of local and state governments it has undertaken many new activities formerly thought to be outside the tasks of government.

Under the direction of the President the ten great Executive *Departments* are working for the good of the people in all the states. *The Department of Commerce* is assisting Amer-

ican business men to sell their goods abroad. *The Department of Agriculture* is aiding the farmer in a thousand different ways. Many more illustrations might be given to show the way in which the Federal Government is caring for our interests.

Buying Government Service

It is well to remember, when we speak of the high cost of government, that it is selling us more and more of these useful services and that our taxes are merely a payment, and a legitimate one, for such services. When a man hires a plumber to thaw out the pipes which have frozen in his home, he expects as a matter of course to pay the bill. We hire our government to give us good water, to keep our streets clean, to help us sell our goods abroad.

From our government come countless services which can only be performed through such agencies which act for all of us. Furthermore, what we spend in taxes for such services, in many cases, actually saves us hundreds of dollars in personal expenses.

Public health measures have greatly reduced the likelihood of our contracting disease. Child mortality today is half, in many cities less than half, that of twenty-five or fifty years ago. Our taxes have helped to bring about this change. Money spent on education is also well spent. *A democratic government, depending upon a prejudiced and ignorant body of citizens to exercise the franchise and elect representatives, will eventually fail.*



The governments work in our behalf has in many cases produced wonderful results. CHILD MORTALITY, today, in many cities, is less than half what it



was twenty-five years ago. ILLITERACY is steadily



decreasing. The safety of Democracy rests on THE VOTES OF INTELLIGENT MEN AND WOMEN.

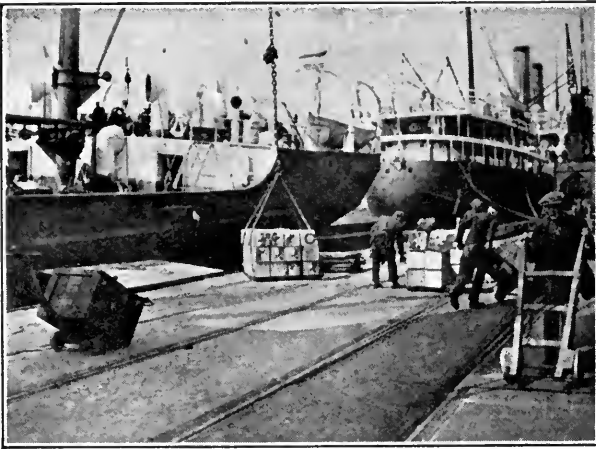

The Federal Government secures taxes from many sources. GOODS THAT ARE BROUGHT INTO THIS COUNTRY are taxed. This form of taxation is called



a tariff. The most important U. S. CUSTOMS HOUSE is in New York City. The U. S. Customs Receipts, 1921, were \$308,564,391. The government



taxes nearly everything that is sold at A CIGAR STAND. Tobacco, in any form, has always been considered a luxury and so has always been taxed. During the war many things sold at a soda fountain were taxed. Many of these taxes have been removed,

What the Government Taxes

Debts, interest charges, and the many activities of the government require a great deal of money. The annual cost of government—local, state and national—in the United States before the Great War was *four billion dollars*. Since that time this vast amount has been greatly increased. Not all of this money is raised in taxation, however, as the government secures part of its expenses in other ways, such as the sale of public lands, receipts from the post-office, water rates, and payments for other services.

In taxing, the government uses many methods to secure money to carry on the public business. The National Government, for example, levies an *income tax* which takes a percentage of the amount earned by an individual over and above a certain stated sum, such as one thousand dollars for a single person, or two thousand, or twenty-five hundred dollars for a married person. The more you earn, the greater the proportion taken by the government. Certain foreign goods—shoes, toys, chemicals, etc.—coming into the United States, are taxed. This method of raising money is called a *tariff*. In former years this was the most important source of national revenue.

The National Government also taxes liquors (for medicinal and scientific use), tobacco, playing cards and oleomargarine. Such taxes are called *Internal Revenue Taxes*. Before the Prohibition Act was passed a very large amount was secured from the manufacture and sale of liquors for beverages. The National

Government also taxes corporations, and at times imposes consumption taxes upon luxuries, such as fur coats, silk stockings and theatre tickets.

State Governments

State governments also use a variety of taxes. Like the National Government some states tax incomes. When people die and leave large sums of money to relatives, or other people, the state may take a portion for its own work. As in the case of the income tax, the state increases the proportion it takes of an inheritance according to the size of the amount of money left. It may also take a greater percentage if the individual to whom the money is left is simply a distant relative, rather than a wife or child. When the *inheritance tax* is increased for such reasons it is called a *Graduated* or *Progressive Tax*. State governments also tax real estate, mortgages, and corporations.

Local governments, acting under state law, also levy their own taxes for their own purposes. To a large extent real estate taxes furnish the bulk of the local government revenue. Retail stores, peddlers, push-cart men, may be required to pay a tax to do business. A new and ever-increasing source of revenue has been found in the taxing of automobiles. There are slightly over 11,000,000 automobiles and trucks in service in the United States. Each must carry a license, which is a tax. On the other hand, the automobile costs the government a great deal of money, through making good roads and traffic policemen necessary.



We must pay taxes not only to the Federal Government but also to our state government. Then there are local government taxes to pay. The state and local governments secure the great bulk of their taxes from **REAL ESTATE**—the land and buildings. Mil-



lions of dollars are also secured from owners of automobiles. Over 11,000,000 **AUTOMOBILE LICENSES** were issued last year by the state govern-



ments. **PEDDLERS AND PUSH CART MEN** pay a tax to the governments of the cities in which they do business. A good part of the money that we pay in taxes goes to state and local governments.



It is very difficult for a government to impose a fair tax on everyone. It tries to make the burden of taxation as light as possible on wage earners—especially **THOSE WITH LARGE FAMILIES.** Those who



enjoy large incomes and **LIVE IN LUXURY** should pay, in proportion, much more. This is just, although no man, rich or poor, should be exempt from paying



a tax. The government also tries to make the payment of a tax as convenient as possible. For this reason the **INCOME TAX** may be paid in quarterly installments. The government also tries to make a tax as little as possible; enough to pay expenses—only.

These illustrations show the many ways used by different parts of the American government to get money to pay their separate bills. A resident in America must pay directly or indirectly village or city, county, state and Federal taxes.

Dangers in Taxation

This variety in taxation methods makes it necessary to define a good tax. The power of taxation is a very dangerous, although an absolutely necessary and useful power of government. Chief Justice Marshall of the United States Supreme Court once said that *the power to tax is the power to destroy.* He meant that this great weapon of the government, if used thoughtlessly, unwisely, or viciously, might destroy any business. The American Colonists of pre-Revolutionary times realized the danger in wrong methods of taxation when they coined the phrase "*Taxation Without Representation.*"

The makers of the Constitution of the United States, to safeguard the people against the wrong use of this power, specifically limited the National Government in its power of taxation. Congress may only levy taxes in order to "*—pay the debts and provide for the common defense and general welfare of the United States.*" All taxes imposed by Congress must be uniform throughout the United States. The Constitution also prohibits any tax or duty upon articles exported.

What Is a Good Tax?

Taxes may be good or bad. Every government must be care-

ful how it taxes its citizens. Adam Smith, the father of modern economics, in a remarkable book called "*The Wealth of Nations*," published in 1776, laid down rules about taxes which are recognized as sound even today, and with which every citizen should be familiar.

First, he thought that *citizens should be taxed according to their ability to pay*. This means that wealthy people should pay in proportion a greater amount than poor people. It does not mean, of course, that the wealthy should pay *all* the taxes. In the second place, *a good tax should be levied at the time and in the manner most convenient for the citizens to pay*. Lastly, *a tax should take out of the citizen's pocket as little as possible above the amount actually needed to run the government*.

The Justice of Taxation

Taxation is compulsory payment for government services. A percentage of the income of every citizen is taken. Taxation always falls, in the end, upon us as individuals. When a man rents a house, his rent includes the tax upon the property. When he buys a suit of clothes, included in the price that he pays the retailer is a percentage of many taxes. For instance, there is the business tax of the retailer, the tax on the real estate—the land on which the store is built and the building—the corporation tax of the manufacturer of the cloth, and the tax on the land on which the sheep is raised or the cotton grown. Just a few of the taxes which the selling price helps to cover have been named. In like manner taxes are



Taxes that have been mentioned are direct taxes. All pay taxes indirectly. Included in THE RENT THAT WE PAY FOR A HOUSE or apartment is part of the real estate tax that the owner of the

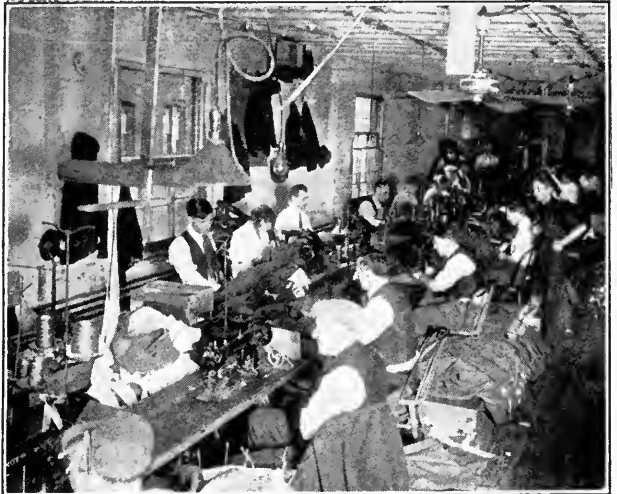

building must pay. The corporation tax that the MANUFACTURER OF CLOTHES has to pay, makes



our suit cost a little more. The same is true when we BUY MEAT AT THE BUTCHER'S, or provisions at the grocer's. We cannot buy anything without paying (indirectly) a tax. The last things that a government will place direct taxes upon are life's necessities—bread, for instance.



The government is faced with two problems. It must constantly plan new ways to raise money through taxation. It must constantly plan new ways to cut down expenses. Hence, the Secretary of the Treasury consults with A COMMITTEE OF CONGRESS as to the best way to solve the first



problem. Just as every individual should make his expenditures come within his weekly wages so every government must bring its expenses within the amount of money that can be raised. But however

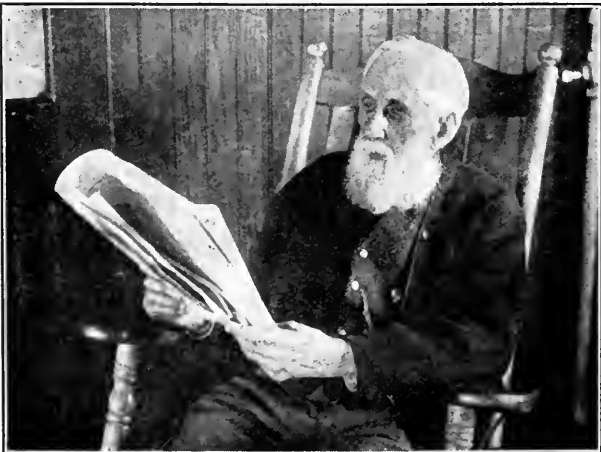

the problem of taxation is solved the average man who reads of the vast sums the government needs, will ever wonder WHAT IT DOES WITH ALL THE MONEY IT RECEIVES IN TAXES.

included in the price that we pay our butcher for the steak or chops that we buy.

In making its taxation plan, the government must be very careful not to tax some of its citizens or some of its industries too heavily. If, for example, it should raise all its money through a tax on real estate, it might make rents so high as to cause good houses to be out of the reach of people living on small wages.

The government must also be careful not to tax business too heavily for that might destroy or drive away trade which, of course, means less prosperity for everyone. Taxation is a difficult matter. It is not easy to find a tax which is just to all.

Unreasonable Demands

Because a very great sum of money is taken in by the government in the form of taxes, many citizens expect it to return to them or their district anything they may want. The inhabitants of a town think nothing of asking the government to build a post-office, for instance, that would in size and architectural beauty be suitable for a good-sized city.

Small boys are constantly asking their parents for a great many things that they see in store windows. They believe their parents have unlimited means. Many citizens have the same point of view toward their government as boys have towards their parents. They think the government has unlimited resources without stopping to realize that each individual must pay his share of the government's cost out of his own

pocket. Just as every individual should make his expenditures come within his weekly wage, so every government must bring expenses within the amount of money that can be raised.

The government cannot do everything that we, as citizens, think it should do. A good government recognizes this fact, plans its *budget* accordingly, and is careful not to undertake too many new activities which will make burdensome and unwise taxation necessary.

Some of Our Complex Problems

There are complex problems demanding immediate solution. At times there is waste and inefficiency, graft and corruption in the government service. This is true of every human organization. Even the most efficient business organization falls short of one hundred per cent perfection. We have the right, however, to get as near one hundred per cent value for each dollar of taxation as possible. We should see that we get value for our taxes.

During the last few years, as a result of the war, this nation has developed a habit of extravagant spending, both individually and governmentally. In fact, the whole world has contracted the disease. Now, as a nation, we must economize. We are beginning to recognize this fact. Congress has provided for a *Director of Budgets* under the President of the United States. This is one of the most important steps that the Government has ever taken. Governmental extravagance must be eliminated. National thrift and the citizen's effort

toward strict economy are necessary if we are to lift the burden of taxation.

The United States has a new point of view toward debt and waste. An aroused public opinion is demanding economy in Federal, State and Municipal Government. But, as President Harding has said: "*It is not easy to change the habits of a country; it is not easy to stand against those who want to spend.*"

Reduction of expenditure means relieving men of their jobs. Inertia, old methods, loose standards, must be met and conquered at every turn. Politicians protest over the elimination of jobs; communities object because certain buildings, such as post-offices, have not been erected in their home towns. The men who undertake the work of reducing national expenditures, or state expenditures, or local expenditures, will always have the cheap and vicious political forces of the country arrayed against them. They must face the whine of the office-holder, the requests of the office-seeker, and the attacks of the politician. A President, a Governor, or a Mayor, attempting to reduce expenditures, has a difficult task.

It is easy to spend, easy to build up the political machine by giving out jobs. To turn about and reduce the number of useless employes and to eliminate unnecessary expense is difficult. Many toes are pinched in the process. Yet every citizen should fearlessly advocate and support the removal of the evil triplets of government: *Waste, Inefficiency and Corruption.*

"It is not your father, alone, who paid for your schooling; your uncle, your neighbor, those who know you and those who never saw you, are taxed to provide the money that educates you. Why? Because the people of America decided that they would govern themselves and that as a people, united in a government, they would educate the growing generation in the principles which distinguish the American government from the autocracies of the old world."—
William McAndrew.

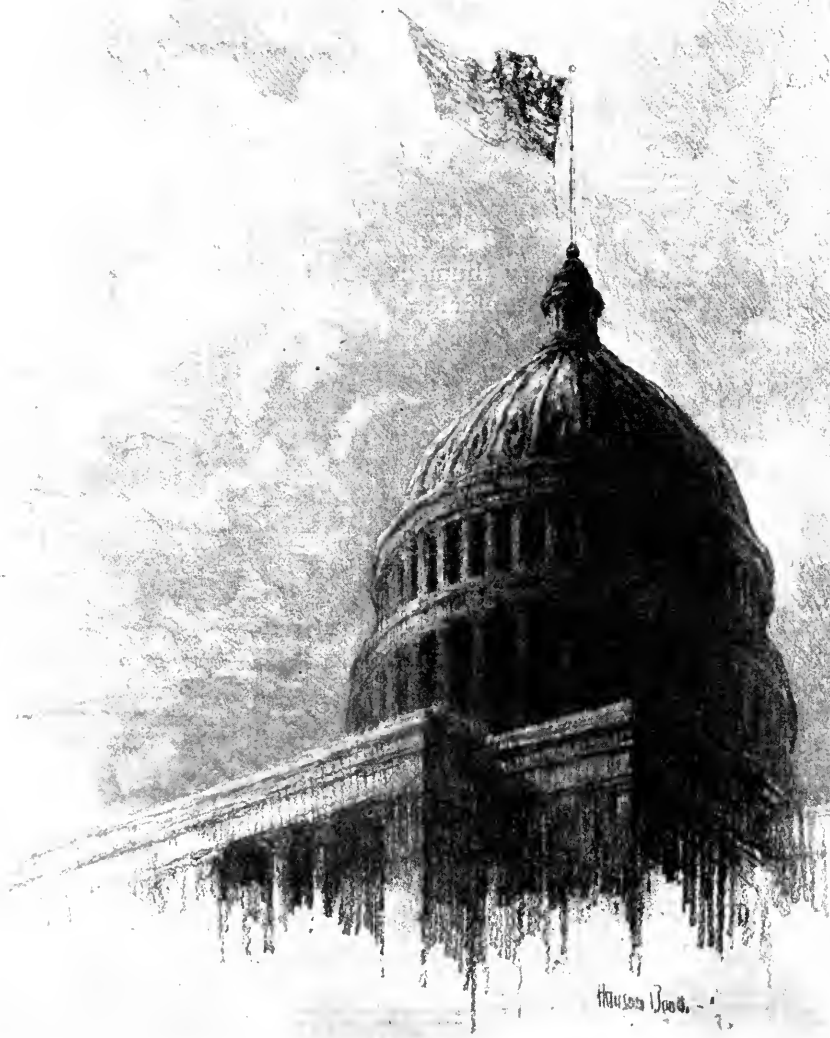

©The American Viewpoint Society

Drawing by Hanson Booth

ONE FLAG, ONE PEOPLE, UNITED UNDER A COMMON GOVERNMENT

We have grown into one people, meeting together, talking together, working and doing
business together

The National Government

“Government *OF* the People, *BY* the People, *FOR* the People”

THE reasons for the separation of the United States Government into *executive, legislative and judiciary* branches, have already been explained in the chapter on the *Mechanics of Government*. The text of the Constitution which you have read, gives the details of this three-fold separation. There are many other important facts, however, about the *President* and his *Cabinet, Congress* and its *legislative work* and the *Federal courts* and their organization, which one must know if he is to understand clearly how the American Government actually works.

The President of the United States

The President of the United States is the outstanding figure in our government. The position of Chief Executive

of this nation places the individual who holds it among the few leading political statesmen of the day. His name is known the world over. His constitutional powers, plus his opportunities to lead and influence the great economic, moral, and spiritual forces of America, stamp him as probably *the most powerful executive in existence*. Indeed, today, the President of the United States has become, among the nations of the earth, an international figure.

The Growth of the Presidency

It was not expected by the framers of the Constitution that the President would become so powerful a personage, but the growth of the nation, and the increasing complexity of our national life, have brought a decided increase in his influence. The office of the President has steadily grown in strength in comparison with other parts of the government, until today, the *American* people look largely to the President for national leadership.

The same tendency towards increasing the importance of the *executive* is to be seen in *state governors* and *city mayors*. They, too, in their respective fields, are looked to for leadership and have much more responsibility on their shoulders than they had a few decades ago. This growth in executive

leadership is one of the outstanding developments in American politics.

The strength of the American President is to be found, first, in his *constitutional powers*, and, second, in his *national prestige* and his *political leadership of his party*. The President's constitutional powers may be discussed under six main headings, viz., his *executive control, appointments, his war power, his position in foreign affairs, his legislative power, and his right to grant pardons*.

True Democracy

“**W**E hold these truths to be self-evident, that all men are created equal; that they are endowed by their Creator with certain unalienable Rights; that among these are Life, Liberty, and the pursuit of Happiness. That, to secure these rights, Governments are instituted among Men, deriving their just powers from the consent of the governed...”

Declaration of Independence



George Washington

Mount Vernon

"FIRST IN WAR, FIRST IN PEACE AND FIRST IN THE HEARTS OF HIS COUNTRYMEN."

These words were spoken in an eulogy of Washington by General Richard Henry Lee, before both Houses of Congress, December 26, 1799, twelve days after the death of "The Father of his Country."

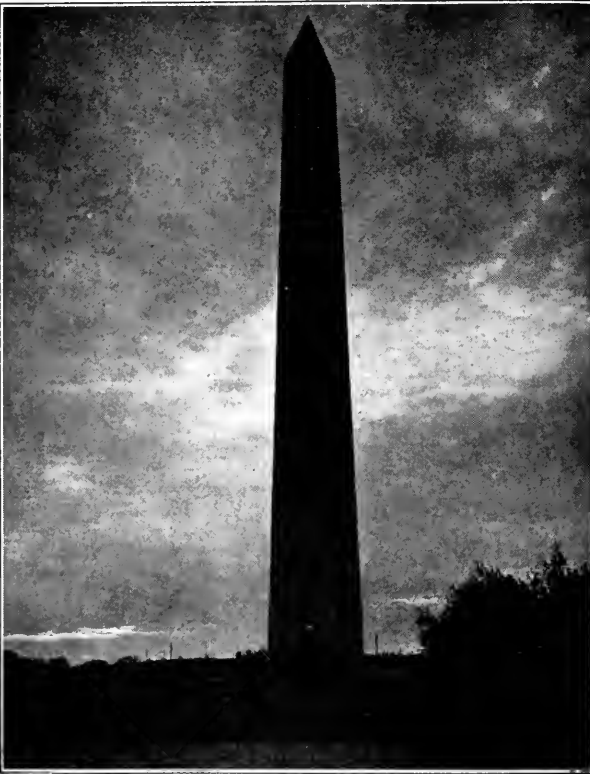

THE WASHINGTON MONUMENT

This notable monument is 555 feet high, 55 feet square at the base. It stands in the Capital City, Washington, and was erected (1848-1885) in honor of George Washington.

His Executive Control

The President is the head of the *national administration* and carries the enormous responsibility of looking after the *actual governmental work*, which, as the country increases in size, wealth and population, has become almost overwhelming. Only a robust, vigorous physique, and an extraordinary capacity for hard, continuous work, will carry a man through the four or eight years of never-ending labor which the American Government requires of its chief. This is even more true in war time, as the lives of Lincoln and Wilson, both war presidents, illustrate.

Appointments

The *power to make appointments*, together with the right, in most cases, to *remove from office*, are two of the President's most important and troublesome duties. *Appointments*—many thousands of them—take much of his time. The appointment of important *officials, judges, ambassadors*, and the members of such bodies as the *Tariff, Inter-State Commerce, and Federal Trade Commissions*, must be confirmed by the Senate.

Naturally, the President has not enough time to go over the records of all candidates—only the most important ones get his personal attention—and must rely largely upon the advice of others. If the appointment to be made is in some state, for example, the *Collector of the Port of New York*, the Senators in that state are, in nearly all such cases, consulted, and their advice as to the appointment fol-

lowed. This custom is called "*Senatorial courtesy.*"

Commander-in-Chief

The President is *Commander-in-Chief of the Army and Navy*, with the right and duty of using the entire strength of the nation to compel obedience to the laws and to meet foreign invasion. His executive control in time of war is enormously increased. Through his *Secretaries of War and Navy*, he makes his appointments in the Army and Navy, directs the movements of troops and ships, and initiates all military policies.

His Power in Foreign Affairs

His *constitutional power in foreign affairs* is closely connected with the President's war powers, for, as Commander-in-Chief of the Army and Navy, he can take measures to repel an attack on the part of a foreign nation. He can take armed action, in fact, against another nation, if an emergency arises, although only *Congress* has the legal power to *declare war*. President Wilson took armed action against Mexico several times during his administration without a declaration of war.

It is within the President's power to recognize the independence of other countries, often a very delicate matter, especially if the country to be recognized has just declared its independence. All *treaties* with foreign countries are first negotiated by the President, generally through his *Secretary of State*, or some specially appointed diplomat. To be formally binding upon the United States, however, and to become a part of its

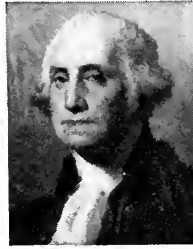

George Washington
1789-1797

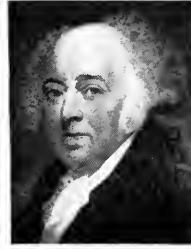

John Adams
1797-1801



Thomas Jefferson
1801-1809

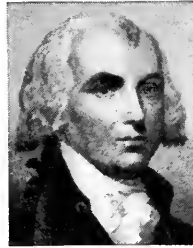

James Madison
1809-1817

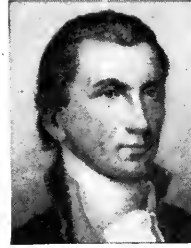

James Monroe
1817-1825

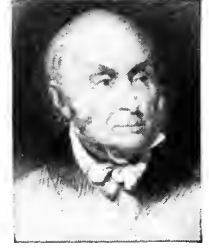

John Quincy Adams
1825-1829

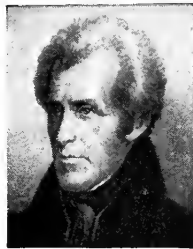

Andrew Jackson
1829-1837



Martin Van Buren
1837-1841



William H. Harrison
1841-1841

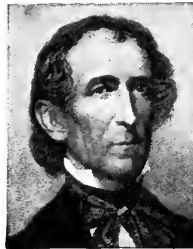

John Tyler
1841-1845

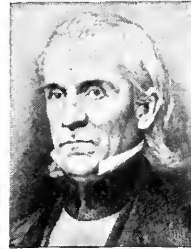

James K. Polk
1845-1849

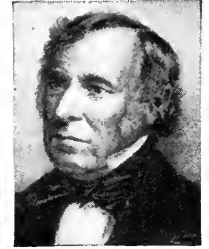

Zachary Taylor
1849-1850



Millard Fillmore
1850-1853



Franklin Pierce
1853-1857



James Buchanan
1857-1861

Presidents of the United States from Washington to Buchanan, inclusive.

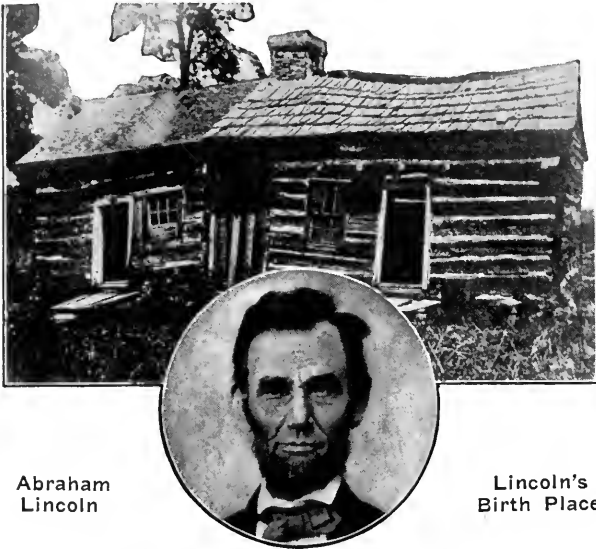

Abraham
Lincoln

Lincoln's
Birth Place

LINCOLN'S GETTYSBURG ADDRESS

"Fourscore and seven years ago our fathers brought forth on this continent, a new nation, conceived in Liberty, and dedicated to the proposition that all men are created equal. Now we are engaged in a great civil war, testing whether that nation, or any nation so conceived and so dedicated, can long endure. We are met on a great battle-field of that war. We have come to dedicate a portion of that field, as a final resting place for those who here gave their lives that that nation might live. It is altogether fitting and proper that we should do this. But, in a larger sense, we cannot dedicate—we cannot consecrate—we cannot hallow—this ground. The brave men, living and dead, who struggled here have consecrated it, far above our poor power to add or detract. The world will little note, nor long remember what we say here, but it can never forget what they did here. It is for us the living, rather, to be dedicated here to the unfinished work which they who fought here have thus far so nobly advanced. It is rather for us to be here dedicated to the great task remaining before us—that from these honored dead we take increased devotion to that cause for which they gave the last full measure of devotion—that we here highly resolve that these dead shall not have died in vain—that this nation, under God, shall have a new birth of freedom—and that government of the people, by the people, for the people, shall not perish from the earth."—(Delivered at the dedication of the National Cemetery, November 19, 1863.)



The beautiful Lincoln Memorial as seen from the top of Washington Monument in Washington.

supreme law, *treaties must be ratified by at least two-thirds of the Senate.*

His Legislative Power

The President in his *messages to Congress reports upon the condition of the nation and recommends necessary legislation.* As he speaks with the voice of the nation and as the leader of his party, his recommendations always carry great weight. The President may also call *special sessions of Congress* to consider legislation which he thinks necessary and which has not been passed in the regular sessions. Often, the threat to call a special session, especially if it is to take place during the summer months, is enough to make Congress do what the President wishes.

The President's disapproval of legislation may be shown in several ways. Constitutionally he can *veto* congressional legislation, and very often a mere hint or threat that he will use the veto is enough to block legislation which he thinks unwise, since it is a difficult thing for Congress to secure the two-thirds vote necessary to pass a vetoed bill over the President's head. Moreover, congressmen who belong to the same party as the President, do not care, unless the issue is very great, to break with the President, as it may possibly injure their own chances of re-election. If a congressman opposes the President, the power of appointment may possibly be used by the President to throw political strength to an opponent of the congressman in his own party.

His Power of Pardon

Among the important constitutional rights given to the President is that of granting *reprieves* and *pardons* for offenses against the United States, except in cases of *impeachment*. The President's pardon power does not extend to offenses against individual states, which is solely the right of a *governor*.

Requests for pardon are usually made to the *Department of Justice*, or, if made directly to the President, referred by him to this Department for recommendation. *The Attorney General*, the head of the Department of Justice, investigates, consults the trial judge and prosecuting attorney, and makes his recommendations to the President. The latter may do as he pleases with the recommendation. He may mark the papers with the words "*pardon granted*" or "*pardon refused*," thus giving a prisoner his freedom or keeping him in prison as he thinks best; or he may grant a reprieve, modifying the term or nature of the punishment.

National and Party Leadership

In addition to his legal and constitutional powers, the very position of the President adds to his prestige and importance and probably makes him the strongest executive in the world. The people of all the states have voted for him. He represents the nation in a somewhat different way from a senator or a representative in Congress.

In still another way does the President possess power. A party has nominated and elected him. While in office he is *the party's natural head*. The party

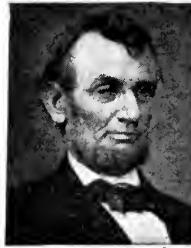

Abraham Lincoln
1861-1865



Andrew Johnson
1865-1869



Ulysses S. Grant
1869-1877

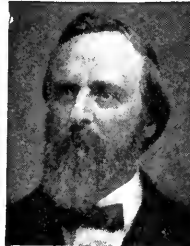

Rutherford B. Hayes
1877-1881

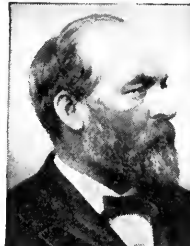

James A. Garfield
1881-1881

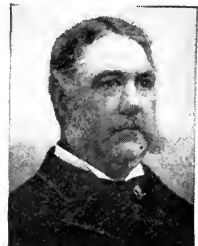

Chester A. Arthur
1881-1885



Grover Cleveland
1885-1889 1893-1897

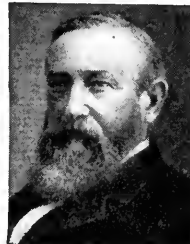

Benjamin Harrison
1889-1893

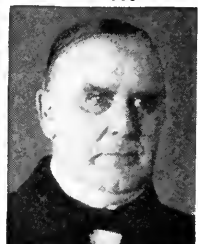

William McKinley
1897-1901



Theodore Roosevelt
1901-1909

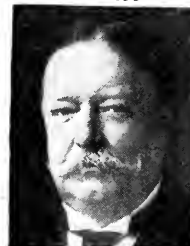

William H. Taft
1909-1913



Woodrow Wilson
1913-1921

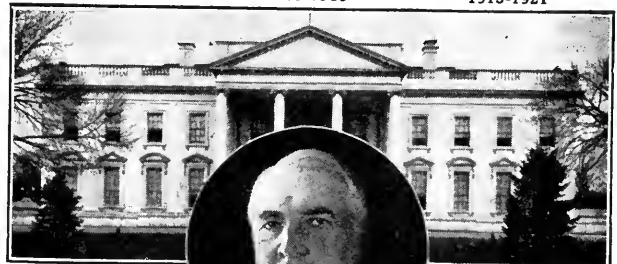

Warren G. Harding
1921-

The White House, Official Home of the Presidents.

Presidents of the United States from Lincoln to Harding, inclusive.



The President of the United States is the head of the National Administration. He carries the enormous responsibility of looking after the actual governmental work which, as the country increases in size, wealth and population, becomes almost overwhelming. HIS CABINET, COMPOSED OF ELEVEN MEMBERS, assist him in this great task. Each member of the President's Cabinet, with the exception of the Vice President, is chosen by the President and becomes the head or Secretary of an Executive Department. This picture shows the members of President Harding's Cabinet at the beginning of his administration, March 4th, 1920. President Harding was the first President to include the Vice President in the Cabinet.

looks to him to see that its platform is carried out; that the administration makes a good record, so that when an appeal is made to the public for continued support at the next election, good campaign arguments will be available. He is *his party's commander-in-chief!*

His Election

The method of electing a President is confusing to many people. The original plan of election, when the Constitution was written, was that the President and Vice President should be selected by a group of men, an *Electoral College*, appointed by each state in such a manner as their *legislatures* directed. *The number of representatives in this electoral college from each state was equal to the total number of Senators and Representatives it had in the United States Congress.*

These representatives, or *electors*, were then to meet in state groups and select the candidates whom they thought would make the best President and the best Vice President. Washington was elected *unanimously* in this manner. After Washington retired, this plan developed many defects, and was later somewhat modified, but we have kept until to-day the old machinery of electors, that, as a unit in each state make the *electoral college* and cast the vote for President and Vice President. For all practical purposes, however, we *vote directly for a President and a Vice President.*

There were *531 electoral votes* in the electoral college in the last Presidential election. A candidate, to be elected Presi-

dent, must have a majority of this number. In case of a tie, or when no one candidate receives a majority in the electoral college, the president is elected by the *House of Representatives* and the Vice President by the *Senate*. If the President should die, he is succeeded, first, by the *Vice President*, and in case of the latter's death, by the *Members of the Cabinet*, in the order in which their departments have been formed. The Secretary of State would come first, the Secretary of the Treasury, second.

The Cabinet

The President's *Cabinet*, the members of which are his intimate advisers and helpers—his *official family* as it is often called—is not mentioned in the Constitution, although it is one of the most important parts of the Government, and is rapidly increasing in power. The work of the members is so striking and so much in the limelight, that they become almost as well known as the President himself. For example, *Hughes, Hoover, Mellon, Weeks, Davis* and other members of President Harding's Cabinet, are almost as well known as President Harding.

In the first place, the members of the Cabinet are the President's *confidential advisers*, and in nearly all cases are picked from the same political party as the President's. In choosing them he takes great care to see that all sections of the country are represented, for in this way the President not only satisfies sectional pride and secures political strength and support, but makes it possible for himself to keep in close touch with men

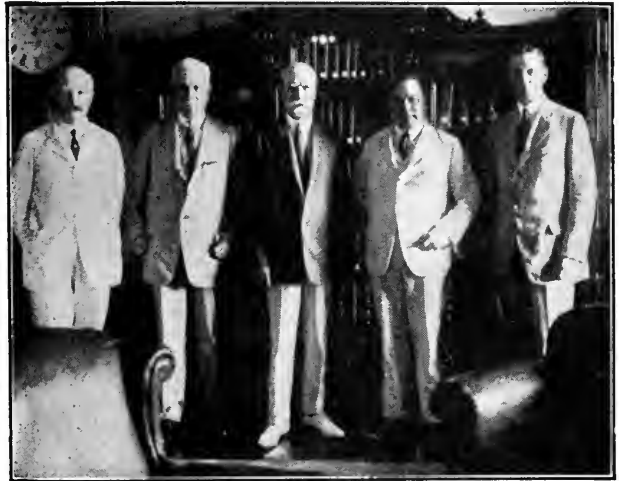

The Department of State is the first Executive Department in the order in which the ten were formed. Its chief work is to look after foreign affairs. In July, 1922, a new treaty between this country and Canada was considered. A DELEGATION FROM CANADA, headed by its Premier, Mackenzie King, held conferences with the head of the Department of State, Secretary Chas. E. Hughes. This

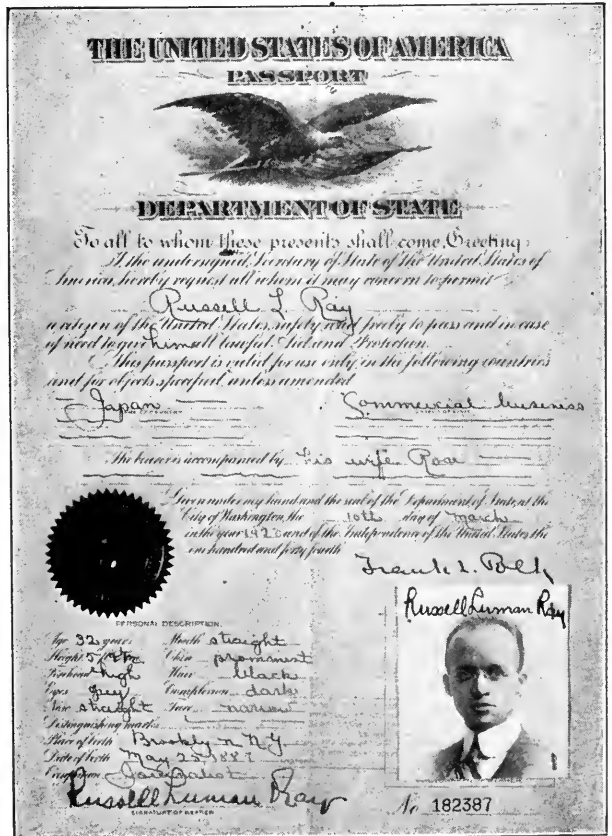

Department also directs United States diplomats, and deals with foreign diplomats. It issues passports. This is A REDUCED FAC-SIMILE OF A PASSPORT.



Next in order is the Department of the Treasury. When the Federal Government wishes to borrow money, it does so through the Treasury Department. During the World War the LIBERTY AND VICTORY LOANS were under the direction of this De-



partment. Its main duties are to collect and disburse money for carrying on the government, care for the health of the people, GUARD THE PERSON OF THE PRESIDENT and his family, make the



U. S. money, GUARD THE COAST against smuggling, and prevent diseases from entering the country.

who thoroughly know public opinion in all parts of the country.

Personal friendship, too, has at times a great part to play in the selection of a cabinet member. Above all, a member of the Cabinet ought to be a good administrator, as he is the head of a large department employing thousands of people.

Cabinet Meetings

Cabinet meetings, where administration questions are taken up, are very informal. The President is never bound by the opinions of his Cabinet although they help him in making his decisions. *He is the only elected official constitutionally responsible for the executive part of the Federal Government's business.*

There are ten executive departments, the heads of which make up the Cabinet. With the Vice President now invited by President Harding, the Cabinet members number eleven.

Department of State

The Department of State looks after foreign affairs. Its work is extremely important, especially in time of war. All *United States diplomats* are under its direction. All *foreign diplomats* carry on their business through it. It also examines and issues *passports*.

The Department of State also keeps and announces all *laws* of the United States, all *treaties*, all *executive orders* and *presidential proclamations*.

Department of the Treasury

The Department of the Treasury collects *national taxes*, pays all the *bills* of the Government and has charge of making *United*

States money. Many other miscellaneous duties and services are under its supervision, such as the *public health service*, *customs*, *coast-guard*, and the *planning of national buildings*.

Departments of War and Navy

The Departments of War and Navy need no explanation, although mention should be made of the *engineering corps of the Army*, which was responsible for the building of the *Panama Canal*, one of the great accomplishments of all history. The War Department also has a *Bureau of Insular Affairs* which has charge of *The Philippines* and *Porto Rico*.

Department of Justice

The Department of Justice is the *legal adviser*, the *legal protector* of and the *legal prosecutor* for the United States. It is also the caretaker of its *penitentiaries* and *prisons*.

Post Office Department

The Post Office Department, in addition to transporting, collecting and delivering the mail, has charge of *postal savings banks* and the *parcels post*.

Department of Interior

The Department of the Interior has many miscellaneous duties, such as the issuing of *patents*, the supervision and selling of *public lands*, care of the *Indians*, paying *pensions*, reclaiming and irrigating *arid land*. The great national parks are in its charge, as is also the fostering of *education*.

Department of Agriculture

The Department of Agriculture gives us our daily weather

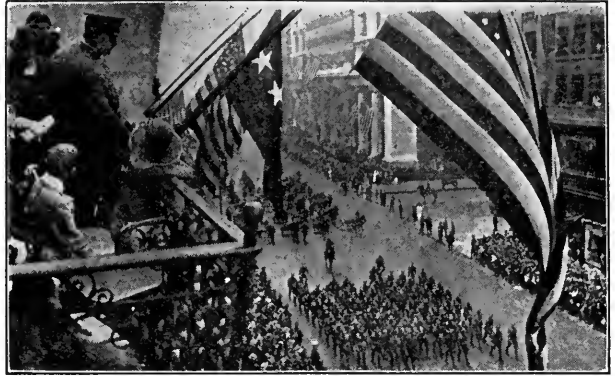

Another important executive department is the War Department. It is responsible for the efficiency of THE UNITED STATES ARMY. The Army of the United States consists of the Regular Army, the National Guard, while in service of the United States,

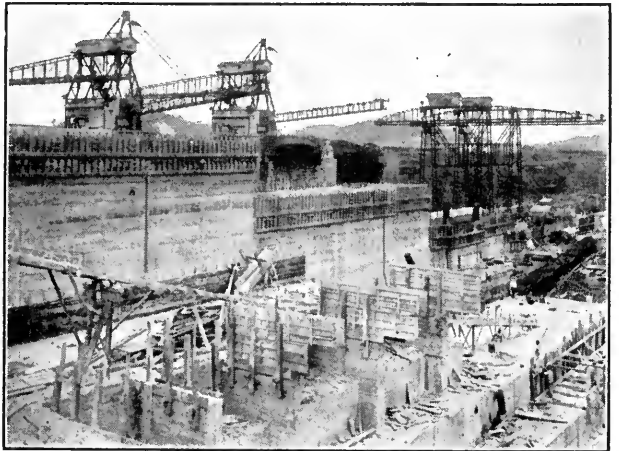

and the Organized Reserves. One of the mighty tasks that the War Department performed was the BUILDING OF THE PANAMA CANAL. This canal is considered one of the greatest works of man. It shortens the water route between New York and

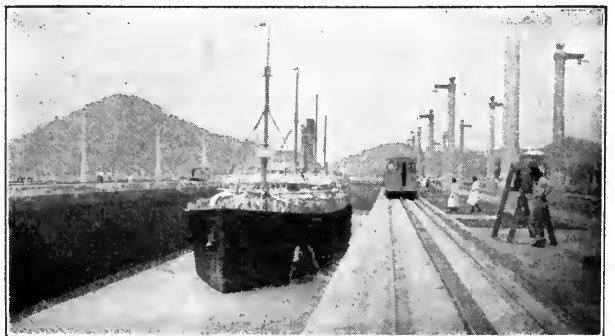

San Francisco nearly 8,000 miles. The canal is fifty miles in length from ocean to ocean. A SHIP CAN PASS THROUGH IT in about 10 hours. 2,892 ships passed through the Panama Canal in 1921, carrying 11,599,214 tons of cargo. The tolls collected by the Government for this year were \$11,276,889.61.



Next is the Department of Justice. This department is the legal adviser, the legal protector of and the legal prosecutor for the United States. Agents of the Department of Justice, assisted by the local police, were engaged during the World War in seizing seditious literature. The Post Office is the fifth great



executive department. Its chief business is to **DELIVER THE MAILS**. It also has charge of Postal Savings Banks and Parcel Post. With the adoption



of the Parcel Post and the ever widening extension of **RURAL FREE DELIVERY**, the work of the Post Office Department has become of increased importance to all the people.

reports, helps the farmer to produce good crops; investigates the values of food and enforces the *Food and Drug Act of 1906*. The great forest reservations are in its charge.

Department of Commerce

The *Department of Commerce* assists in the development of *foreign* and *domestic* commerce, takes the *census*, operates *fish hatcheries*, supervises *light-houses*, inspects *steamboats* and makes *coast surveys*.

Department of Labor

Last, but not least, is the *U. S. Department of Labor*. In it are to be found many Bureaus and Divisions vital to all of us. *Naturalization* and *Immigration* are two great problems under its jurisdiction. Statistics about the condition of labor in the United States are issued by it and an Employment Service is conducted by this department. Two very valuable Bureaus in the Department are the *Children's* and *Women's Bureau*. The first gives its attention to questions of *child welfare*, while the latter looks after the interests of *wage-earning women*.

Boards and Commissions

In addition to these Cabinet Departments, there are a number of important independent *Boards* and *Commissions*. They are constantly growing in number, especially as the Government extends its aid to and increases its supervision over the business of the country. The *Interstate Commerce Commission*, with its control of railroads, the *Federal Trade Commission*, which is the great business supervisor of the

nation, the *Federal Reserve Board*, under which our banking system is organized and operated, the *United States Shipping Board*, with its task of developing American merchant shipping, and the *United States Tariff Commission*, are some of the most important of these independent agencies.

Independent Establishments

The Government of the United States is the greatest of all modern publishers. It employs hundreds of scientists, who are engaged the year round in making researches and investigations in all branches of agriculture and household economy, in geology, in mining, in electricity, in chemistry, in astronomy, in engineering, in aviation, in preventive medicine, in forestry, in irrigation, in transportation problems, in trade and manufactures.

The results of all these activities are constantly reduced to print and poured out in an incessant flood from the *Government Printing Office* at Washington, the largest printing plant in the world and the most comprehensive and effective organization ever known.

These documents have the freedom of the mails and are sent without postage at the cost of printing only.

The *United States Civil Service Commission* is the largest employment director in the world. It annually selects thousands of men and women to do the work in the departments and bureaus of the Government.

The *Library of Congress* houses thousands of priceless books and is the official custodian of Gov-

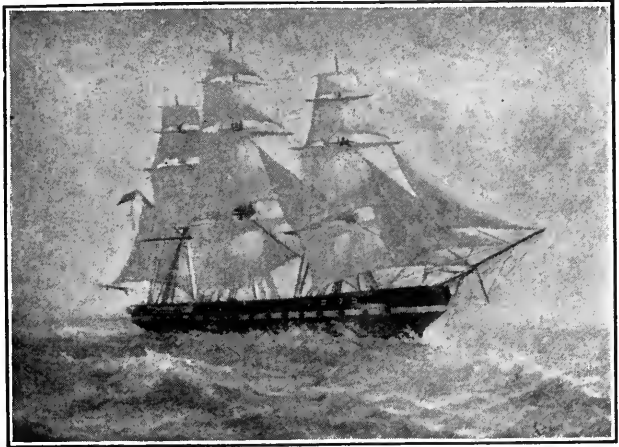

The Navy Department comes sixth. Above is a picture of the famous old warship, *CONSTITUTION*, nicknamed "OLD IRONSIDES," that brought such glory to the American Navy in the War of 1812.

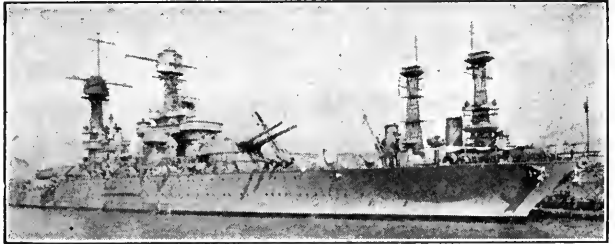

Compare this veteran of by-gone days with a late addition to the United States Navy, *THE TENNESSEE*.

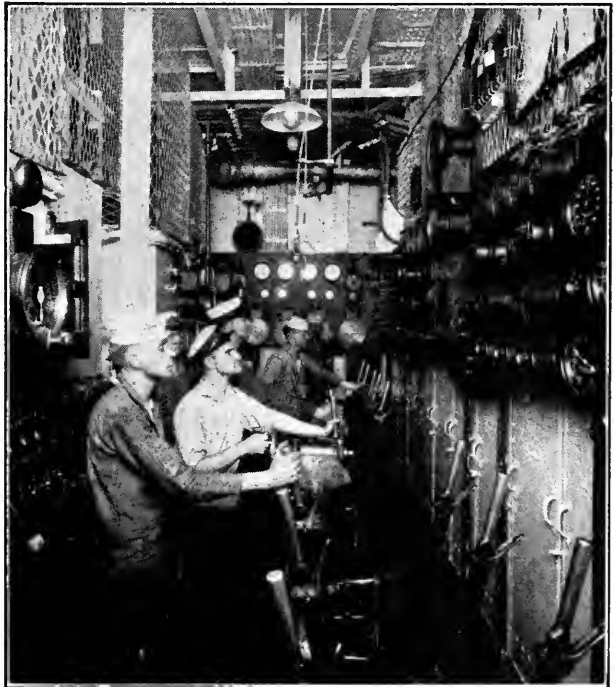

SEE. This triumph of modern fighting craft is OPERATED BY ELECTRICITY.



The Department of the Interior has many duties to perform, chief of which is to RECLAIM AND IRRIGATE ARID LANDS. Millions of acres of desert land now produce rich crops in abundance.

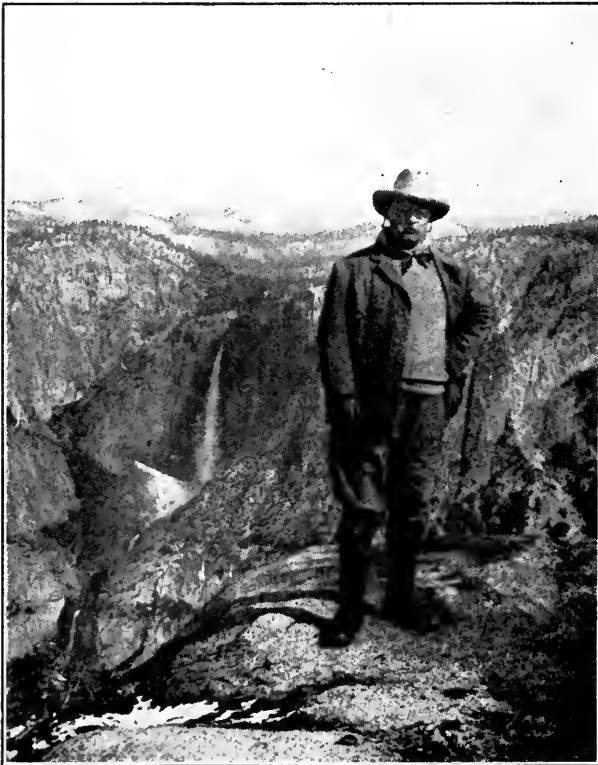

The nineteen great national parks of this country are also under the care of this Department. This picture shows Theodore Roosevelt visiting the Yosemite National Park. This park contains 1,125 square miles.

ernment publications. *The Smithsonian Institution* is another educational part of the United States Government. It has conducted many wonderful investigations into the history and customs of *American Indians* and has collected thousands of specimens and fossils illustrating past and present animal life in this country.

The United States Congress

The law making body of the National Government is called the *Congress*, and through it the people of the United States put into legal effect all policies under which they are to be governed. The Congress is composed of two bodies, the *House of Representatives* and the *Senate*.

Several reasons influenced the makers of the Constitution in adopting a two-house plan for the national legislature. The fathers of the Constitution did not think it altogether wise to give such great power to one single body, which, if not checked by a second house, might hastily pass ill-considered laws. The value of a second or upper house was expressed by Washington, when he said that *the Senate would be a saucer in which the tea of the House would be cooled*. A Congress, composed of two Houses, was also a compromise between the large and more thickly peopled states and the smaller ones. The *House of Representatives* was organized to represent the people, the *Senate* to give equality to the individual states.

In practice, the plan has worked very well. It has brought to bear on all national

legislation two bodies composed of representatives elected in different ways, and therefore looking at questions from different angles. Through the House of Representatives and the Senate working jointly, the Government of the United States has been stabilized, hasty legislation has been checked, and the laws that have been passed have been the result of thorough consideration.

The House of Representatives

This is often called the *lower* or *popular House*. Representatives are elected from *435 congressional districts*, distributed among the states according to their population. A new distribution of congressional districts takes place every *ten years* according to the new census. The term of a member of the House is only *two years*.

All representatives go out of office and come into office together, so that the House changes its makeup every two years. For this reason, those members who have been re-elected many times—Joseph Cannon and the late Champ Clark are two good examples—often have a great personal control over the House on account of their leadership in committees and their intimate knowledge of procedure and rules.

The Speaker

The organization of the House is very complex, but there are two factors in the organization which everyone should know about; first, the *Speaker*, second, the *Committees*. The *Speaker of the House*, elected by its mem-



The Department of Agriculture looks after the welfare of the farmers. It takes care of our national forests. It does everything possible to prevent **FOREST FIRES** that each year destroy timber val-



ued at about \$17,000,000. It inspects the products of the **GREAT SLAUGHTER HOUSES** of the country; enforces the Food and Drug Act, and for this pur-



pose, **MAINTAINS LABORATORIES** IN WASHINGTON and other places where experts analyze food-stuffs sold in stores and shops.



The Department of Commerce has very important work to do. **IT TAKES THE CENSUS** every ten years. The last one was taken in 1920. By this census the population of the continental United States was

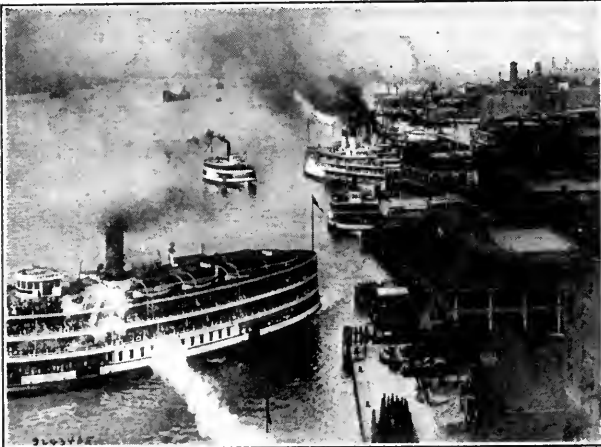

found to be 105,710,620. This Department **INSPECTS STEAMBOATS** to make sure that they are safe and that their owners comply with all the requirements of the law. It builds and operates light-houses, and



charts waterways in order to lessen as much as possible marine disasters. Perhaps the most important duty of the Department of Commerce is to assist in the development of **FOREIGN AND DOMESTIC COMMERCE**.

bers, is in a position of real influence. Up to recent times, when his power to name all members of Committees was taken from him, his influence in American government was considered next to that of the President himself. At one time his power over legislation was so great that he was called the *Czar of the House*, but in 1910 he was shorn of much of his control and power.

This power is now largely in the hands of *committees* and the *floor leader* of the majority party. The minority party also has its floor leader who is the captain that directs the attack on the policies of the majority leader and his party.

The Speaker still has numerous rights and privileges, including the one to recognize the members of the House when they wish to speak on the floor. He also makes the House appointments to committees which meet in conference with the Senate.

From twenty to twenty-five thousand bills are presented at each session of Congress. A little arithmetic will show anyone that the House would have to keep in continuous session every day in the year, morning and night, if it gave only a few minutes consideration as a body to each one of these bills. The great majority of them, however, never get beyond their first reading.

House Committee System

There are over *sixty permanent standing committees* in the House to handle this enormous number of bills. Among the more prominent ones mentioned in the newspapers are the *Com-*

mittees on Ways and Means, Appropriations, Judiciary, Banking and Currency, Rivers and Harbors, Agriculture and Military Affairs. Many of the committees have sub-committees to consider special subjects.

These committees always have their majority and minority members. When the Republicans are in the majority in the House they control the committees and the Democrats have only a minority representation. If the Democrats are in control, it is just the opposite. Membership on a committee depends on the length of time that a member has been in the House. New members of the House are put at the foot of the list and must make their way upwards as committee members.

The United States Senate

The Senate is a continuous body, since only one-third of its membership changes every two years. The Senate does not elect its own presiding officer since the Constitution gives it one in the *Vice President*, who, however, can vote only in case of a tie. The Senate also has its committee organizations.

Senators are more likely to be re-elected than the Members of the House, therefore the Senate does not change its makeup as often or as much as the House of Representatives. This longer term of office allows a Senator to resist better the pressure of immediate considerations. It gives him prestige and importance. Individuals stand out more prominently in the Senate since it is a very much smaller body of men than the House. Debates



The last Executive Department is the Department of Labor. Its work is to gather labor statistics and to assist in IRONING OUT DISPUTES BETWEEN EMPLOYERS AND EMPLOYEES. Immigration is

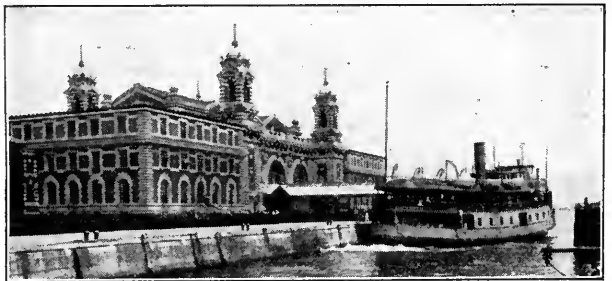

another activity. THIS DEPARTMENT ALSO HELPS ALIENS TO BECOME NATURALIZED CITIZENS. Two very valuable Bureaus in the De-



partment of Labor are the Children's Bureau and Women's Bureau. The first is concerned about CHILD WELFARE, the second looks after the interests of wage-earning women.



In addition to the ten Executive Departments named, there are the independent establishments of the Government, chief of which is the **CIVIL SERVICE COMMISSION**. This Commission examines all those who seek employment in any of the competitive classified civil service positions. There are about 76,000 such positions in Washington and over 500,000 outside. Another important independent

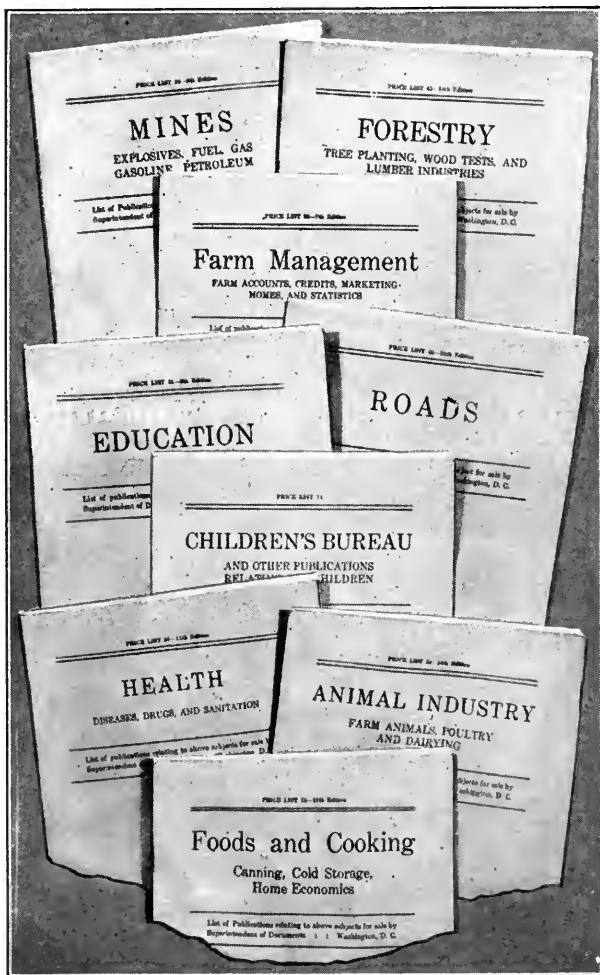

office is the **GOVERNMENT PRINTING OFFICE**. Every one should avail himself of the opportunity which the Government gives to secure at a very low price **MATTER WRITTEN BY EXPERTS ON ALMOST ANY SUBJECT**. There is just one condition to the liberal offer of the Government and that is that payment be made in advance.

are more important. Many great American orations—Daniel Webster's and John C. Calhoun's on the nature and the powers of the Federal Government—were made on the floor of the Senate.

In the *House*, because of its large membership, in order to get business done the right to talk must be strictly limited. In the *Senate*, it is unlimited, and is sometimes used to talk bills to death. Such an attempt to kill a bill is called a "*filibuster*."

Passing Bills

All bills for *raising revenue*, according to the Constitution, must be first introduced in the *House of Representatives*. Every other kind of bill can start in *either* House.

Let us take a bill which has been introduced in the House of Representatives, and trace its course until it becomes a law of the United States.

A copy of the Bill, which may be introduced by an individual member or by a chairman in behalf of a Committee itself, is endorsed with the member's name and is sent to the *Clerk's table*, where it is *numbered* and *recorded*. The Bill is then referred to the proper committee for consideration. A *bill on immigration*, for example, goes to the *Committee on Immigration and Naturalization*. This constitutes the first reading. If, on *reading* it, the Committee does not feel that it is a good bill, it simply drops it and does nothing—makes no report on it. Thousands of bills are *killed* in this way.

If the Committee thinks the bill has merit, it may do one of several things. It may *report the*

bill back to the House as it is written; it may *amend* the bill, and report it as amended; or it may *write a bill of its own* along similar lines and present it to the House with a favorable recommendation. In the latter case, the bill is very likely to pass. If it is a very important bill it goes through a long series of committee hearings, at which any person in favor of it or against it may appear.

The bill is then taken up in a *private session of a committee*, at which its final form is decided upon. Each bill must have *three readings*. The first is by *title* only, as indicated. At the second reading the *whole* bill is given. Amendments may then be offered by the Committee or others and voted upon.

The question then comes up "*Shall the bill as amended be engrossed and read a third time?*" Here, besides the contests on the amendments, the real struggle and debate takes place. Those in favor of it and those against it debate. The question is then put to a vote. If it passes, the bill must come up a third time, usually by *title* only. With few exceptions, a bill reaching the third reading is passed with little difficulty.

Goes to Senate

The bill is then sent to the *Senate*. It is not necessary to describe in detail the procedure of the Senate, which corresponds closely to that of the House. Bills go through the same three readings. Usually, however, the Senate has many changes or *amendments* to make.

As no bill may become a law

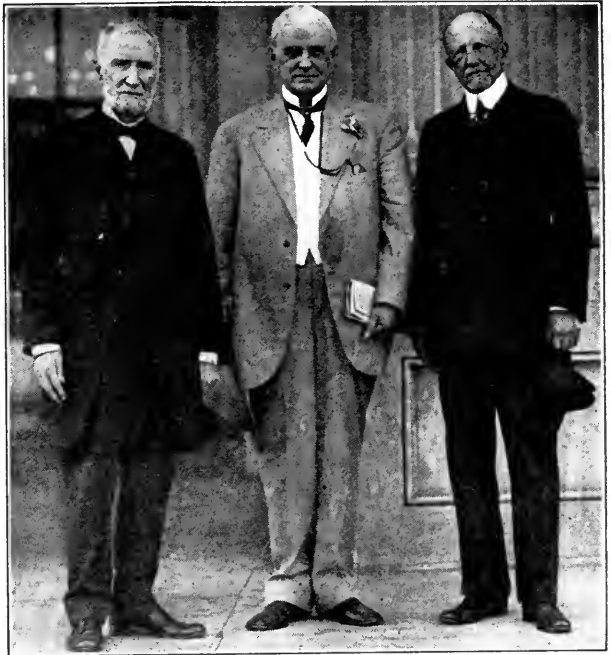

The legislative branch of the government is The Congress. The most important member of the House is the Speaker. Two recent Speakers of the House were JOSEPH G. CANNON and the late CHAMP CLARK. The present Speaker is FREDERICK H.



GILLETT. There are over 60 standing committees in the House to handle the enormous number of bills

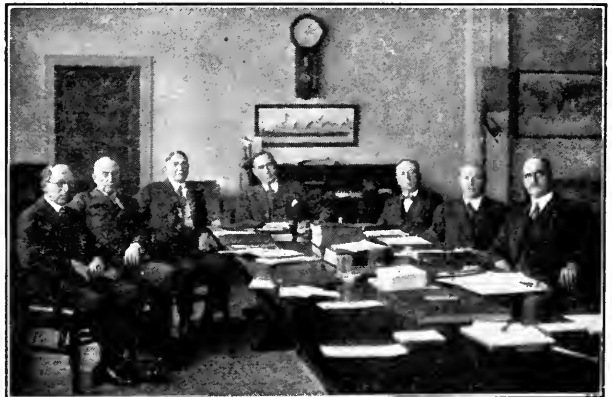

which are presented at each Session of Congress. The Senate has a corresponding number.

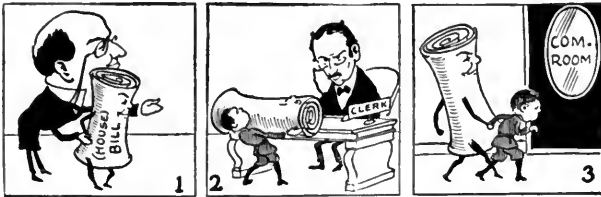

The course that a House bill must take before it becomes a law is about as follows:

(1) A bill is introduced in the House and (2) is sent to the Clerk's table where recorded, and (3) is referred to the proper Committee.

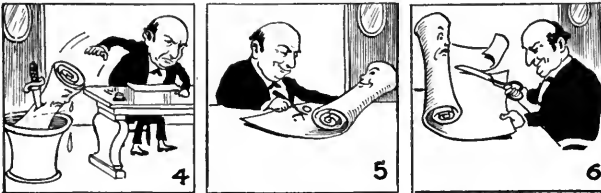

In Committee the bill is either (4) killed, or (5) endorsed, or (6) amended—



Or (7) rewritten. Then it (8) is taken up in Committee and (9) discussed in secret or private session.

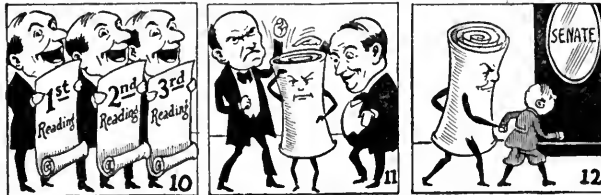

A bill (10) has three readings; and (11) is debated and amended. If passed it (12) goes to the Senate.

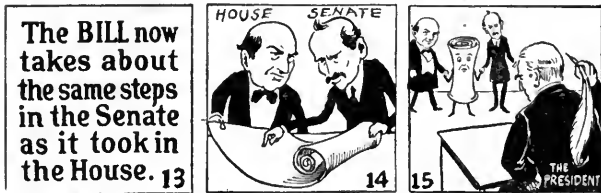

See (13). Then (14) representatives from both Houses decide upon its final wording; then it is put to a final vote. If passed it (15) goes to the President.



If (16) the President vetoes the bill, it goes back to Congress. If passed by a two-thirds vote it is law unless (17) the Supreme Court decides it unconstitutional. If constitutional, it (18) remains a law.

unless it is passed *in exactly the same form by both chambers*, something must be done to bring about an agreement. A *conference committee* is appointed, made up from members of the Senate and the House. This committee meets, adjusts the differences, and formulates a final bill which is then referred back to the Senate and to the House of Representatives.

If passed by both Houses, it is sent to the President, who has the right to *accept* it or *veto* it. If he accepts it, *the bill becomes a law of the United States*. If he vetoes it, it fails unless it is passed again by a two-thirds vote of each house; in that event it becomes a law without the President's approval.

Goes to President

A bill passed by Congress and signed by the President must in some cases jump another hurdle before being finally accepted as a United States law. This final hurdle is the *Federal Courts*, which *interpret the Constitution and statute law*.

Federal Courts

The Federal Courts have been organized so as to make them as *impartial* as is humanly possible, as much in a democracy depends upon the people's confidence in the integrity of this branch of government.

The *Judges* of these courts are appointed by the President, which appointments must be *confirmed* by the Senate. They are appointed for life on good behavior, so as not to be subjected to the whim or the partisanship of any one moment. It

is their duty to *interpret the law*, and *the Constitution* as it is, without favor to any individual, group or class. Sometimes its decisions prove unpopular with certain groups and bring partisan attacks on the courts.

Everyone must remember that some agency, in the kind of government that we have, must finally decide whether this law or that law violates the Constitution. Any body of men who of necessity must make such important decisions is at times unpopular. However it is not the duty of the court to meet popular opinion. It is to interpret the Constitution.

It would seem, in looking over the history of the United States that *the courts have, on the whole, done their duty wisely and impartially and have interpreted the words of the National Constitution and the laws passed by Congress in a manner which has allowed the United States to make sound and consistent progress along political, economic and social lines.*

The Supreme Court

The Courts of the United States consist of *three groups*. The first and most important, and at the head of the American judicial system, is the *United States Supreme Court*. This Court is made necessary by the Constitution but the details of its organization have been left to Congress. It now consists of a *Chief Justice* and eight *Associate Justices*. The Chief Justice receives \$15,000 a year; the Associate Justices, \$14,500.

The jurisdiction of this court is discussed in Section 2 of Article 3 of the Constitution. It



The highest court in the American Judicial System is the UNITED STATES SUPREME COURT. Owing to the death of Chief Justice Edward D. White



in 1920, William Howard Taft was appointed by President Harding, with the consent of the Senate, to become the new Chief Justice. Before taking this position, Ex-President Taft, as all officials must do, **TOOK THE OATH OF OFFICE.** In May, 1922,



members of the United States Supreme Court re-dedicated, at Philadelphia, THE BUILDING IN WHICH THE FIRST SUPREME COURT OF THE UNITED STATES HELD ITS SESSION, 133 years ago.

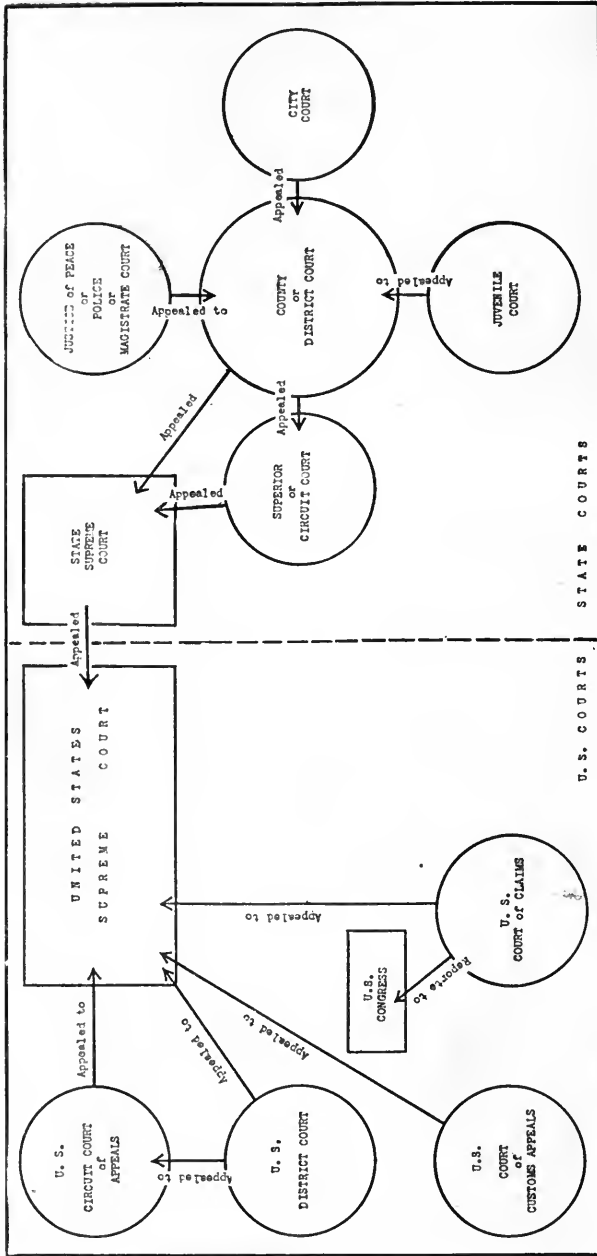

The Federal and State judicial systems are shown by this chart. The reader will note how certain cases, starting in the lowest courts, state or national, may be carried through the higher courts and eventually to the United States Supreme Court.

The Federal Courts have been organized so as to make them as impartial as is humanly possible, as much in a democracy depends upon the people's confidence in the integrity of this branch of Government. All the Judges of the Federal Courts are appointed by the President, which appointments must be confirmed by the Senate. Judges are appointed for life on good behavior, so as not to be subjected to the whim or the partisanship of any one moment.

has original jurisdiction over certain kinds of cases, that is, it hears these cases for the first time. Most of its work, however, consists of deciding cases which come to it on appeal from other federal courts or state courts. On the whole, however, it only passes on a very small percentage of all laws that are passed and it never gives a constitutional decision except on an actual case which is brought before it. All decisions are made by majority vote.

Many Justices of the Supreme Court, and especially the Chief Justice, who actually has no more power in making decisions than the other judges, have been outstanding figures in American government.

John Marshall was probably the most noted of the Chief Justices. His constitutional decisions in our early history were so important and had so great an effect in determining the working form and powers of our government and had so great an influence on American life that he has been called the "Ex-pounder of the Constitution."

Circuit Court of Appeals

The next court is the *Circuit Court of Appeals*. Nine great circuit court judicial districts have been organized in the United States, each district having four, three, or two justices, as the case may be.

These circuit courts were organized to relieve the Supreme Court of a great deal of its work, especially in hearing cases of appeal from the lower courts. In some instances a circuit court decision is final. The Circuit Courts also enforce and review

certain orders and decisions of such bodies as *the Inter-State Commerce Commission*, *the Federal Trade Commission* and *the Federal Reserve Board*.

District Courts

The next lower order of federal courts is *the District Court*. There are *eighty-one* such districts in the United States, in each one of which is a *District Judge*, although some districts have more than one. There are over *one hundred Federal District Judges* in the United States. These courts hear cases involving *crimes against the Federal Government*, *internal revenue cases*, *crimes against the postal laws*, and *infringements of copyrights or patents*.

Each Federal District Court has a *United States District Attorney* for purposes of prosecution, and a *marshal* to carry out the decisions of the Court. Decisions of the District Court may be appealed to the Circuit Court, and in some cases directly to the Supreme Court.

Special Courts

In addition to these three orders of courts, there are some special courts. *The Court of Claims* has been organized to hear all cases brought against the United States on account of salaries, payment for supplies, or other damages. It is composed of one *Chief Justice* and four *Associate Justices*.

The Court of Customs Appeal is likewise organized to hear disputes arising over the *tariff laws*. An importer may bring in a large consignment of goods on which he must pay a duty; he may question the duty which has been imposed and bring his claim up in the Court of Customs Appeal. This Court has a *Chief Justice* and four *Associate Justices*.

In addition to these two special courts,

courts have been organized for the District of Columbia, Hawaii, Alaska, Porto Rico and The Philippines, territories or dependencies of the United States that are organized in a different manner than are the forty-eight States of the Union.

A United Country

Through these three branches of Government—Executive, Legislative and the Judicial,—the National Government carries on the great tasks given to it by the Constitution. These tasks are constantly increasing in number and variety. This is necessarily so, and is simply a result of the natural growth of the nation.

America began with a few isolated outposts along the Atlantic Ocean—among others, Jamestown, Virginia; Plymouth, Mass., and New Amsterdam, New York. As the colonies grew together their dependence upon each other increased. At last they united in a common government, one that we use to-day. Under it the different parts of the nation have continued to grow closer together, until to-day north, south, east and west need each other more than ever before. New York, Chicago, San Francisco, and New Orleans are now more nearly alike, closer together than the Boston and New York of Revolutionary days. We have grown into one people, meeting together, talking together, doing business together. The United States is more than a government, it is a great society, knit together by railroads, telephones, newspapers, books, schools, commerce and industry. The National Government in the ways just described looks after the common needs of this great society, while the state governments, described in the following chapter, look after the more local tasks.

“All men are entitled to a hearing in the councils which decide upon the destiny of themselves and their children.”—*Andrew Johnson*.



©The American Viewpoint Society

Drawing by Hanson Booth

A UNITED NATION OF FORTY-EIGHT STATES
The state provides for the governmental needs of farm and city

State Government

State Government is that Division of the American Federal System that Touches the Daily Life of the People

FROM the cradle to the grave every American is influenced in some way by *state government*. When a child is born, state law immediately requires a *birth certificate*. The doctor who looks after him when he contracts a child's disease is *licensed* by the state. A *state compulsory education law* sends him to school at the age of six. Before he is allowed to attend classes, the state requires that he be *vaccinated*. His school is organized under state authority and supervision. His teachers are *licensed*. If the boy leaves school at an early age, he is required to have *working papers*. If he becomes a chauffeur, a *state license* to drive must be secured. If he enters a factory, his hours of work and conditions of labor may be *regulated by state law*. If injured, a *state workmen's compensation act* protects him.

Instead of leaving school, however, he may continue his education through the *high school*, and after that through a *state university*, paid for by state taxes. He may win a *state scholarship* giving him free tuition. He may be graduated as a dentist, a doctor, or a lawyer; but before he can begin to practice, he must pass a state examination and secure a *license*. If he wishes to marry, a *marriage license* must first be

secured. His wife desires an automobile, which he purchases; but he finds that before he can run it a *state license* is needed, and a *state tax* must be paid. His marriage may turn out unfortunately. If so, he and his wife may be divorced according to state law.

If the young man becomes a farmer, *state agricultural experiment stations* are ready to assist him. If he becomes a railroad executive, he is subject to the orders of a *state public utility or public service commission*. He may run a milk company, and then *state health laws* must be observed. He may conspire with other men in his own line of business to raise prices or to form a monopoly. Then the state, under its *anti-trust laws*, may fine him or send him to prison.

When he is eventually overtaken by old age, disease or accident, and is pronounced dead by a *licensed* doctor, the state requires a *permit* for his *burial*. Even his undertaker must have a *license*. After death the state still retains some form of control over the property he has left behind him. Under state law his property is divided. Finally, a part of what he leaves may be taken by the state in the form of an *inheritance tax*.

The state, as these various illustrations have indicated, is in close contact

Close to the People

THE title of "The United States of America" is an exact description of our government; a federal union of states... State government must be kept close to the people. It must work for their social and economic interests, since it is that division of the American federal system which is charged with looking after intimate human needs.



From the cradle to the grave, every American is influenced in some way by state government. At BIRTH the State requires a BIRTH CERTIFICATE. A LICENSED DOCTOR writes it out. At six a state law SENDS THE CHILD TO SCHOOL.



His TEACHER is licensed. If the youth works during vacation, WORKING PAPERS authorized by the state must be filled out. After Public School he may go to a STATE UNIVERSITY.

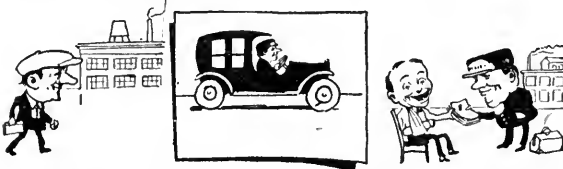

If he goes to work in a factory his HOURS OF LABOR may be regulated by the state. If he runs a taxi he must secure a STATE LICENSE. If he is injured while at work, a STATE WORKMEN'S COMPENSATION LAW protects him.



If the young man enters a profession—DENTIST, LAWYER, or CERTIFIED PUBLIC ACCOUNTANT—he must secure a license.



If he MARRIES, buys an AUTOMOBILE, or goes FISHING, he must first secure, in each case a STATE LICENSE.

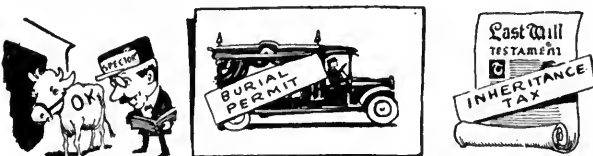

His FOOD AND DRINK are inspected by the State. He dies, and is BURIED by State permit. His heirs pay an INHERITANCE TAX on what he leaves.

with the social, economic, and educational life of its people, but it also exerts its sway in another manner.

The National Government rests upon the states. They are necessary to its successful operation. State law, for example, determines who may vote in national elections. States are divided into the districts from which congressmen are elected. Candidates for national office are nominated under state regulation. Even amendments to the National Constitution are made possible through the vote of state legislatures.

An Exact Description

The title of "The United States of America" is an exact description of our government: a federal union of states. How important it is, then, to everyone that state government be properly organized, that its different parts work together smoothly, that it be run honestly, efficiently and economically.

If this important part of our government becomes honeycombed with graft and corruption, if our state officials are men of small calibre, then we are injured in every vital step that we take during our lives. State government must be kept close to the people. It must work for their social and economic interests, since it is that division of the American federal system which is charged with looking after practical human needs.

Although in details state governments vary widely, their general organization is similar in many ways. State governments correspond closely to Federal Government in organization.

The State Constitution

The foundation of every state government is its *constitution*. Before the Federal Constitution was adopted in 1787, each of the original thirteen states had already written and adopted its own constitution. Since that time, thirty-five additional states have been admitted to the Union, each with its own constitution.

Congress determines whether or not a constitution, which a state must present before admittance to the Union, is satisfactory. It may ask a state before admittance to make certain changes in its constitution, or may even refuse a state entrance into the Union on account of the character of this instrument.

State Legislatures

The *state legislature* determines the policy of state government. It is made up of two bodies, a smaller or upper house, generally called the *senate*, and a larger or lower house, which in some states is called the *house of representatives*, in others, the *assembly*, and in a few, the *house of delegates*.

For purposes of electing state senators, a state is divided into *senatorial districts*, whereas representatives to the lower house are elected from smaller divisions, generally called *assembly districts*. A state legislature usually meets once in two years, but in a few states once a year.

No body of men in America wields legal powers so vital to all of us as the members of a state legislature. A *state legislature* possesses every power not forbidden by state or national con-

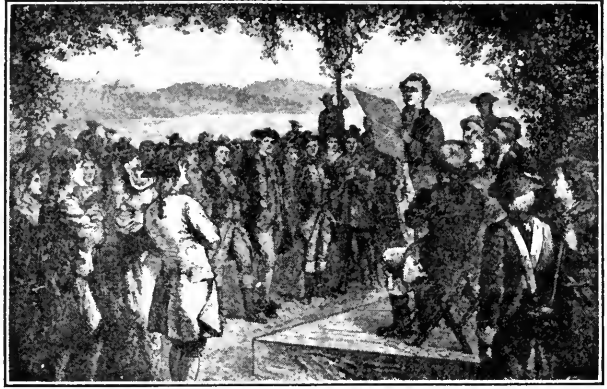

The foundation of every state government is its constitution. Since 1787, when the Thirteen Original States became the United States of America, 35 states have been admitted to the Union. Before admission, these states were called territories. This picture shows the INAUGURATION OF THE NORTH-WEST TERRITORY at Marietta, Ohio, 1783.

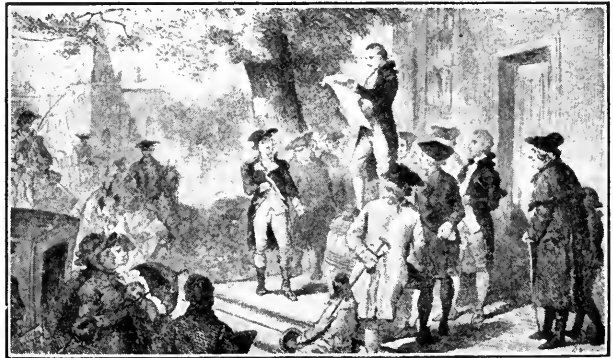

New York State ADOPTED ITS CONSTITUTION in 1777. The City of Albany was chosen its capital.



THE LEGISLATURE AT ALBANY determines the policy of government of the State of New York.



A state legislature composed of two bodies, an upper and lower house, meets in the State Capitol building and there conducts the business of the state. Photographs of a few of the State Capitols are here shown.

State Capitols of (1) Kentucky at Frankfort, and (2) Pennsylvania at Harrisburg.

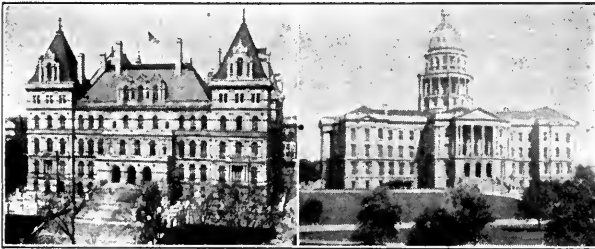

State Capitols of (1) New York at Albany, and (2) Colorado at Denver.



State Capitols of (1) Wyoming at Cheyenne, and (2) Ohio at Columbus.



State Capitols of (1) Vermont at Montpelier, and (2) Connecticut at Hartford.



State Capitols of (1) Texas at Austin, and (2) Washington at Olympia.

stitutions. On account of the wide range of subjects with which it deals, a vast amount of business comes before every state legislature. In consequence, these bodies pass thousands of bills on a great number of subjects every year. For this reason every voter on election day should be very careful to consider the men and women who offer themselves as candidates for a state legislature.

In order to get through with their work, *committees* closely patterned after those in the National Congress are chosen. Bills in a state legislature, as in Congress, are first considered by a *committee* and go through *three readings*.

The power of the *speaker* of the lower house and of the *floor leaders* in both houses of a state legislature is even greater than in Congress.

The Governor

The chief executive of a state is the *governor*. He occupies a position very much like that of the President of the United States. There is this difference, however: in the National Government the President is the sole officer elected and held responsible for executive work, while in the states the governor is not the only executive officer elected. Usually the *secretary of state*, the *treasurer*, the *comptroller*, the *attorney general*, and sometimes other officials have their own duties to perform and are not responsible to the governor. In most states they are elected by the people and are responsible to *them*. The governor, unlike the President, has no cabinet. The chief executive officials are not

his organized advisers, though he often must consult them. He stands alone and is in a weaker position in the state than our President is in the nation.

This is so because when the first state governments were organized the people who wrote the constitutions had firmly fixed in their minds the abuse of executive power which had been exercised by the old colonial governors. Therefore, in order to forestall a too powerful executive, the position of governor was weakened. In many instances he was simply made a figurehead and the state legislature was made the supreme outstanding feature in the state governmental machinery.

Nevertheless, with the growth of our state governments and the great increase in their activities, an increased need for executive leadership has arisen. This, coupled with the enormous and alarming growth in state budgets, has brought the governor to the front. *To-day the people of the states are looking more and more to their executive chief for guidance and leadership.*

Governor's Legislative Power

The governor, in addition to seeing that the laws are carried out, has much legislative power. He *sends messages* and makes *recommendations* to the legislature. He may use the *veto* on bills sent to him for approval. He can call *extra sessions* of the legislature to consider special subjects which he believes should be enacted into laws. For example, former Governor Hughes, of New York State, some years ago called a special session of the legislature



Next to the President, a state governor is the most important executive in American public life. A successful governor is very often considered for the position of President or Vice-President.

(1) William McKinley (2) Grover Cleveland (3) Woodrow Wilson (4) Theodore Roosevelt were state governors before they became President. (5) James M. Cox, Democratic candidate for President, 1920, was Governor of Ohio. (6) Vice President Calvin Coolidge was Governor of Massachusetts. (7) Chas. E. Hughes, the Republican Candidate for President in 1916, was Governor of New York. (8) Former Vice President Thomas Marshall was Governor of Indiana.



State activities may be grouped under a few main headings. A state's most important work is education, and **CITIZENSHIP TRAINING** is a feature of



this work. Another feature is the provision that the state makes through its agricultural colleges to give information on farming. This picture shows a class in the **STATE AGRICULTURAL COLLEGE OF WISCONSIN**, studying soils. A state government



grants licenses. For example, a doctor may not **PRACTICE MEDICINE** unless provided with a license granted by the state.

to pass anti-gambling and race track legislation. Budget reforms in a number of states are also bringing the governor more directly into the problem of making appropriations.

Governor's Appointing Power

The governor makes many appointments to office subject to the approval of the state senate and these, as in the case of the President, take a great deal of his time. He can remove many officials from office on charges of misconduct or neglect of duties. A governor is the *commander-in-chief of the state militia*, with the right to use it in case of riots or uprisings. This power was exercised by Vice President Coolidge, when he was Governor of the State of Massachusetts, in policing the City of Boston during a policemen's strike. If a governor needs federal assistance, *he can call upon the President for troops*. He likewise has the power of pardon and reprieve. In addition, he has many social duties to perform.

Next to the President, a governor is the most important executive in American life. A governor with strength of character, initiative, and the ability to lead, means much to the happiness and safety of the citizens of a state. Men who make their mark and stand out as governors are very often considered for the position of President of the United States.

The Lieutenant Governor

In over half of the states a *lieutenant governor* is also elected. He generally presides over the meetings of the state

senate and fills the governor's place when the governor is ill, absent, or when he dies in office.

In addition to the governor, there are a number of other elected officials, each of whom is responsible to the people for his share of the state's work. Usually there is a *secretary of state*, a *treasurer*, a *comptroller or auditor*, and an *attorney general*. Still other officials, who may be elected or appointed, as the case may be, are the *superintendent or commissioner of education*, and the *commissioners of banking, of insurance, of highways, of labor, of industries, of public works, and of health*.

Boards and Commissions

Every state, in addition to these officials, has a great number of separate miscellaneous *offices, boards and commissions*. State government when it first began was a very simple matter, and included only a few elected officials and not many activities. But the stupendous growth of business, the rapid increase in wealth and population, and the endless multiplication of social problems have led to an enormous expansion in state administration. Activities have increased to such an extent, in fact, that only a few years ago New York State found, on investigation, that it had 187 separate boards, commissions and other agencies carrying on the State's work. Massachusetts discovered 216, and Illinois was attempting to do its work with 130 such divisions.

Civil Service

The vast army of public servants necessary to carry on these many activities has



Next comes the Sanitary and Public Health work of the state. Officials of a state government inspect food sold in the stores and markets. Inspectors also TEST THE SCALES AND MEASURES used in the

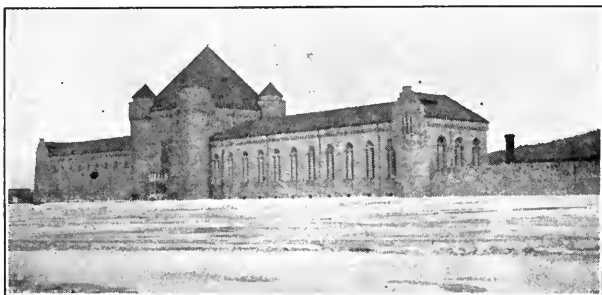

sale of merchandise. A state maintains asylums for the insane, the deaf, dumb, and feeble-minded. PENITENTIARIES are built and maintained by the



state. At police headquarters a "ROGUE'S GALLERY" containing photographs of all prisoners, is kept. Here also is kept the Bertillon measurements of each prisoner. The measurements are very complete and include, for example, the length of the prisoner's ears, the distance between his eyes, etc. But of the first importance is a photograph of his finger print. This is very carefully filed and preserved.



THE STATE GOVERNMENT BUILDS ROADS. This interesting photograph shows where a road built by one state stops at the boundary line of its neighboring state. A state government **BUILDS**

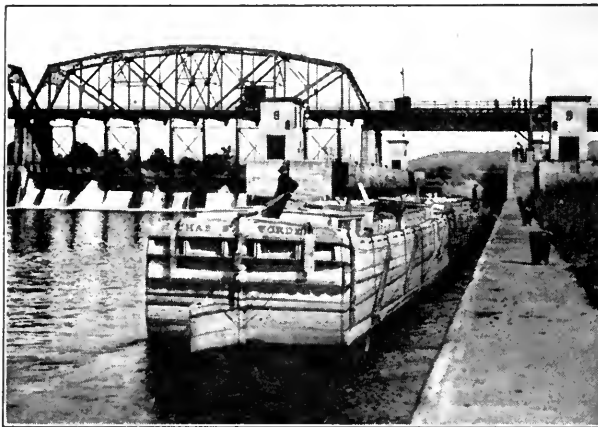

CANALS, widens and deepens streams, and **CONSTRUCTS BRIDGES**. There are about seventy-five State Canals, with a total canal length of slightly over one thousand miles. The original cost of building these seventy-five canals was in excess of \$366,000,000. Added to this sum must be the annual



cost of upkeep. For the pleasure and instruction of the people, the states maintain great **PUBLIC PARKS**.

brought to the fore the great question of the *civil service*. Appointments to the majority of state positions are now in the hands of the *state civil service commission*, acting under *state civil service laws*. No matter how efficiently a civil service commission may act, however, many grave problems constantly arise over the methods that should be used to promote civil service employes, to keep this great body of men and women keyed up to efficiency and to exclude graft, corruption, and the spoils system from the state service.

State Activities

Although state activities are many, they may be easily grouped under a few main headings. To begin with, there is the great work of *education*, supervised by a *state board of education*, and directed by a *state superintendent* or *commissioner* and his assistants. Closely related to education is the duty of a state to draft the rules for the *granting of licenses* to those who desire to become doctors, lawyers, dentists, teachers, public accountants, or to enter many other professions or occupations.

Public Health

Next comes the *sanitary* and *public health work* of a state, usually in charge of a *state department of health* and its *commissioner*. There are still to be considered the great welfare and correctional activities carried on in *asylums* for the insane, the blind, the deaf and dumb, the feeble-minded, and in the many *reformatories* and *prisons* and in the courts.

Public Works

These unfortunates in our welfare and penal institutions must be housed in buildings. Here enters another important state activity—*public works*—such as the erection of public buildings to house them. Other important public works include the making of *highways, canals*, and the laying out of *state parks*.

Agriculture

Agriculture is very important and much is done by the government of a state to see that this foundation of our country's economic life is well looked after.

Development and Conservation

The development of *water power*, the *conservation of forests*, of *mines*, and of other great wealth-giving resources are all important state activities.

Labor Protected

Labor must not be forgotten. Every state has thrown many safeguards around its laboring population. *The state protects its women and children against long hours and bad conditions of work*. In some states minimum *wage commissions* have been set up in order to see that these workers receive at least living wages. *Workmen's compensation commissions* have been organized to do away with the long delays resulting from court actions, and to substitute for the former inadequate and unjust payments for accidents a new system of legal payments based on the seriousness of the injury received.

State Militia

Still another function of state government is the organization

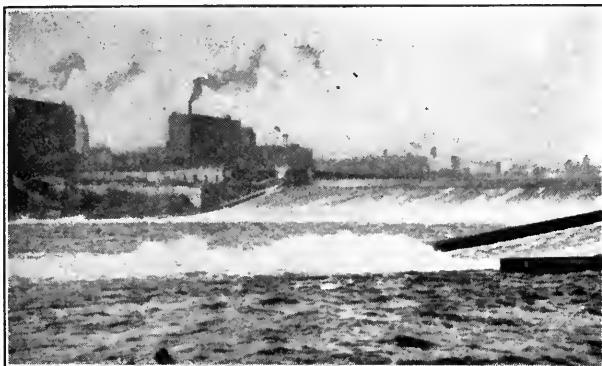

The **DEVELOPMENT OF WATER POWER** is another important work of state government. Of recent years, the states have become exceedingly

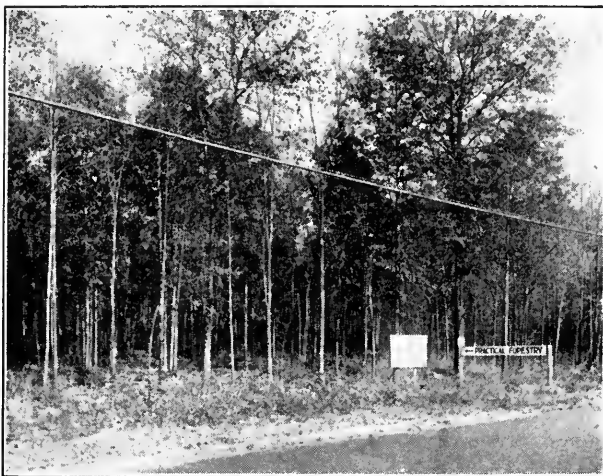

active in the **CONSERVATION OF FORESTS**. The country is very rich in mineral deposits. These must be conserved. The total value of the mine and



quarry products of the United States in 1920 was \$6,707,000,000. In the State of Pennsylvania alone, over 180,000 men are employed in mining anthracite coal, and about 615,000, in bituminous mines. This is a group of **PENNSYLVANIA COAL MINERS**.



A state government protects labor. In each factory, in many states, it posts "LAWS RELATING TO INSPECTION OF FACTORIES", and compels factory owners to conduct their business according

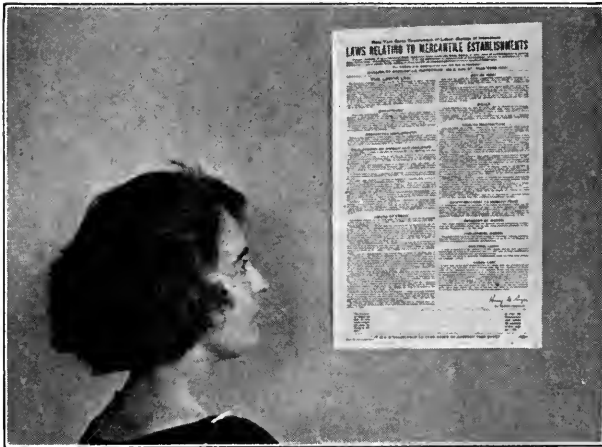

to the laws governing factories. In like manner, the owners of stores and shops are compelled to run their business according to "LAWS RELATING TO MERCANTILE ESTABLISHMENTS." To do away with

GENERAL FORM No. 3 6-21-30-20,000 (20-722)

NOTICE

—

The undersigned, an Employer within the meaning of the Workmen's Compensation Law of the State of New York, hereby gives notice to his employees, to all persons interested, and to the public, that he has complied with all the rules and regulations of the State Industrial Commission and that

secured the payment of

the lengthy court trials in cases where the adjustment of payments for accidents are considered, many states have passed "WORKMEN'S COMPENSATION LAWS," and require that a statement of this law be posted wherever men and women are employed.

of the *state militia*, which includes the building of *armories* as *regimental drill centers*. Some states also have a police system of their own. The *state constabularies* of New York and Pennsylvania are examples.

Business Safeguarded

One of the largest tasks of state government concerns itself with those activities which connect government and business. States hold to strict supervision and accounting *banks* and other financial institutions, such as *life insurance* and *trust companies*, which are trusted by so many thousands of people with their property and their savings. *Public utilities*, such as *railroads*, *gas* and *electric light plants*, *telegraph* and *telephone companies*, also carry on their work under the eye of the state.

Tax Collections

Last, and possibly the most important of all the duties of a state, is the *collection of taxes* to pay for all these activities of state government.

Higher State Courts

Each state has its own *system of courts* and *judges*. State judges differ in two important particulars from federal judges. In the first place, in the majority of states, judges are elected by popular vote instead of being appointed. Some states, however, have their higher judges appointed by the governor with the consent of the state senate. The state of Massachusetts goes still farther in having its Governor appoint all judges direct.

State judges, in the second place, instead of being appointed

for life or good behavior, in practically all cases serve for definite terms of office ranging from two to twenty-one years.

At the head of the state judiciary is the *supreme court*, sometimes called the *court of appeals*; or, as in New Jersey, *the court of appeals and errors*. This usually consists of from five to nine judges. This court does in the state what the federal Supreme Court does for the Union. It protects the rights of the citizens guaranteed in the state constitution, interprets statute law, and keeps the different parts of state government in their place, preventing them from overstepping their constitutional positions.

In about one-third of the states provision has been made for *superior* or *circuit courts*, occupying about the same place and doing about the same kind of work in the states that the Circuit Courts of Appeal perform in the National Government. These two higher courts hear cases which are appealed from the lower courts.

County or District Courts

The *county* or *district court*, or *court of common pleas* as it is sometimes called, is a lower court—a trial court—corresponding in many ways in its position in the state to the federal district court in the National Government. This court settles important civil disputes between individuals; tries important criminal cases, and, in some states, looks after the rights of minor orphan children and the distribution of property left by people who have died. In most states, however, *county*, *probate*, *circuit*, or or-



A State Government maintains A MILITIA and

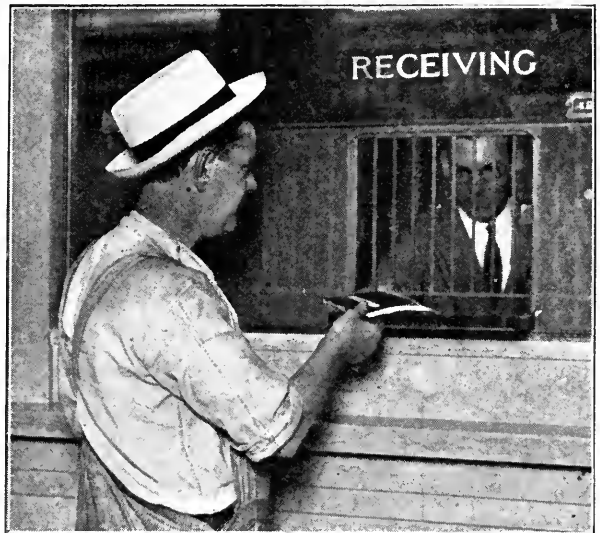

builds armories. When one DEPOSITS MONEY IN A BANK or PAYS AN INSURANCE PREMIUM, it is comforting to know that the banks, life insurance companies, and other financial institutions must



give a strict accounting to the state. Public Utilities such as SUBWAYS, railways, etc., also operate under state supervision.

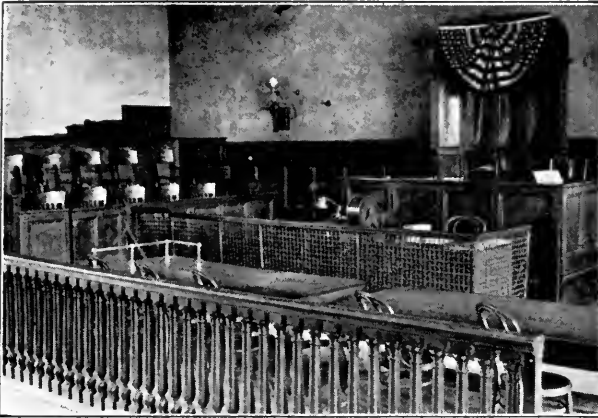

Each state has a system of courts and judges. All the lower courts—county, city, magistrate and municipal courts—are under the jurisdiction of the state. The interior of all courts is about the same as here shown. One should never forget that



trial by jury is a constitutional right of every one in this country. Therefore, each court room has a place built especially for the twelve jurors. Note the chairs to the left of the first photograph. If we



are to have good laws and good courts, everyone must recognize his responsibilities and help in whatever way he can. If we desire good judges we must vote for honest, capable, and impartial men.

phans' courts are organized separately to attend to these very important matters.

Lower Courts

Many minor crimes or misdemeanors are committed in every community. For example, a man may become drunk, or drive his automobile faster than the law allows or disobey other traffic regulations, or he may have a fight with his neighbor, or play *craps*. It is not necessary, in the vast majority of instances, to hold a person committing these misdemeanors for a county or a district court which is set aside to try the more serious criminal and civil cases.

Possibly 75 to 90 per cent of the cases which arise in a community are of this minor character just described. All states have organized *lower courts* to look after such matters.

In the country districts, *justices of the peace*, usually elected by the voters of a township or some other county subdivision, attend to such matters. In villages, towns, and small cities, *the magistrates' courts* do the same kind of work. In both of these courts it is possible to look after minor *civil cases* as well as criminal cases. As a community grows larger and cases become more numerous this double task is not possible.

In the larger cities the *magistrates* or *police courts* confine themselves to trying persons charged with minor offences. In Chicago, in New York, and other large cities, for example, special magistrates' courts are even set aside to look after those who violate traffic regulations, those who commit immoral acts, and

families which have domestic difficulties of one kind or another.

Juvenile Courts

It is now generally recognized in America that children who commit crimes or who need correction for waywardness should not be *haled* before the regular courts and brought into contact with hardened criminals and their vicious influences. Provision is now made by most states for *children's or juvenile courts*. Judge Ben Lindsey of Denver, Colorado, is known the world over for the work he has done with juvenile offenders.

Poor Man's Courts

City or municipal courts are also provided in cities for the settlement of thousands of small lawsuits often involving workmen and their wages. These are frequently called the *people's or the poor man's courts*.

It is very necessary that the minor civil cases coming up in these courts, which individually may not amount to

much but which in the aggregate touch thousands of poor people, should be handled quickly, inexpensively and fairly. Otherwise much dissatisfaction is sure to arise.

If we are to have good state laws and courts, every one must feel his responsibility and help in whatever way he can. If we desire able and upright judges, we must vote for honest, capable and impartial men.

Throughout this chapter emphasis has been placed upon the fact that the state is that part of American government which touches the daily life of the people. It is impossible, however, for a state to do all of this work through its own machinery, for the task of administration would be too great. A state depends upon local subdivisions to do many things for it. It delegates many of its powers to units of local government. State government cannot be understood unless one also knows something of *the county, the town, the village, and the city*.

"A state grows in power as its citizens become enlightened."—*Storrs*.

† † †

"The work of a state in the long run is the work of the individuals composing it."—*Mill*.

† † †

"The very idea of the power and the right of the people to establish government pre-supposes the duty of every individual to obey the established government."—*Washington*.

† † †

"The law of nations is founded upon reason and justice, and the rules of conduct governing individual relations between citizens or subjects of a civilized state are equally applicable as between enlightened nations."—*Grover Cleveland*.

† † †

"Every citizen should obey the law, even when striving to alter it. . . . He need not praise the law which he obeys. He need not pretend to think it wise, carefully drawn, just or expedient, but he should obey it, even though striving meanwhile, by every lawful means, to convince the majority of the justice of his objections. . . . To aid him in his fight for good laws the ballot is given him."—*R. M. McElroy*.



©The American Viewpoint Society

Drawing by Hanson Booth

THE VILLAGE MEETING

Practically every citizen is a part of four Governments: viz., National Government, State Government, County Government and Village Government.

Local Government

Local Government is a Matter of State Control Exercised in accordance with State Legislation within the Rules of a State Constitution

PRACTICALLY every citizen of the United States is a part of at least *three* governments, the vast majority of people of *four* or even more. First, he belongs to the *National Government*; second, the *state*; third, the *county*, and with few exceptions, one or more other units of government such as a *city*, a *town*, a *village*, or of a *school*, *fire*, *sanitary*, *drainage* or other special district.

A few facts from Illinois will indicate the variety and the number of these state subdivisions. This **West-**ern State has *102 counties*, *70 cities* with a population of 5000 or over, *1400 townships*, about *800 villages*, over *12,000 school districts*, and, in addition, a variety of other districts such as those formed for *sanitary*, *park* and *drainage purposes*.

No wonder it is so difficult for an individual to understand all the details of local government. The details are so many that it is only possible in this chapter to suggest the variety of forms local government takes and some of the important officials who look after our local needs. Nevertheless, as these parts of government touch our daily life at every turn, everyone should take as active an interest as possible in the local government of the community in which he lives.

Smaller Units Necessary

The very same reasons that make it necessary and wise for every state to look after its own needs, also make it desirable that each state be sub-divided, for convenience in governing, into smaller units. These sub-divisions look after their own local needs; they are also utilized by the states as convenient

agencies to carry out state laws covering certain matters, such as, *police protection*, *the collection of taxes*, *caring for the poor* and *the insane*, and *providing for public schools*.

A state, in other words, finds it desirable and wise to delegate some of its powers to these smaller units. In this manner the execution of state law is made more flexible and better suited to the varying conditions

which exist in different *rural districts*, *villages* and *cities*.

It is not altogether correct, however, to compare this division of tasks between the state and its subdivisions to the division that exists between a state and the National Government. In the latter case, *the state governments have absolute control over their own affairs*. The National Government cannot step in and cannot interfere with their work. Local state units, on the contrary, are merely

100 Different Ways

WHERE the National Government touches the individual once, and a state government ten times, local government comes into contact with the individual in a hundred different ways...An efficient and honest local government means everything to the happiness of the people and is the foundation upon which stands a strong state and nation.

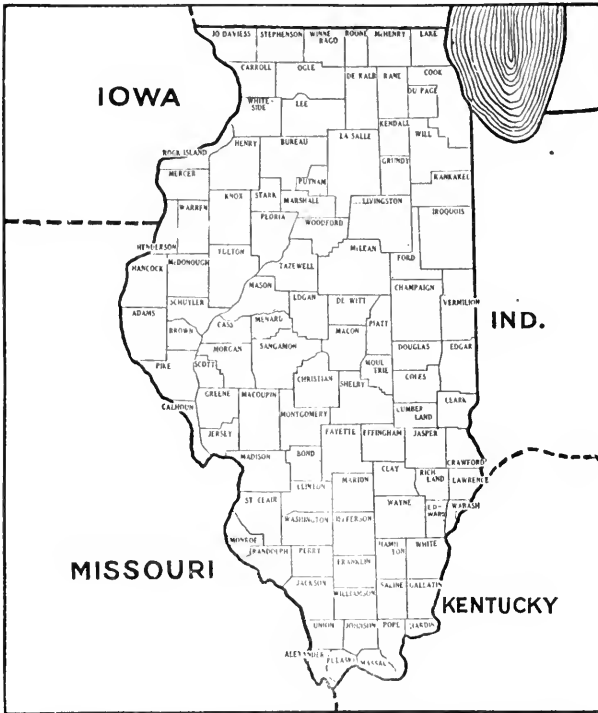

Each State of the United States is divided into counties; the counties, into smaller units. THE MAP SHOWS THE COUNTIES IN THE STATE OF ILLINOIS. In the counties are located cities, towns and villages. Each of these divisions of the state has

the creatures—the agents—of the state. Local government is a matter of state control exercised in accordance with *state legislation* within the rules of a *state constitution*. Local government is a child of the state. It can be organized or divided up, or done away with, as the state thinks best. Cities and other units object, at times, to this control of the state when it becomes arbitrary, or is used for partisan or corrupt purposes.

Many states have put in their constitutions home rule provisions protecting local government, especially cities in their organization and work, but within such restrictions, a state is free to act as it pleases. A state legislature may itself grant cities or towns or counties the right to govern themselves to whatever degree seems best. As this question of home rule mostly concerns the city, it is discussed more fully in the following chapter.

Local Government Varies

The variety of forms and names used in American local government is due to the fact that in the United States it had its roots in the earliest settlements that were made—at *Jamestown*, at *New Amsterdam*, and at *Plymouth*. The *county* and the *town*, for example, the two most important and widely used units of local government, were brought by the early Colonial settlers from England, where they had already gone through a long history of development. During their long development in the United States, they have assumed many



local government. THE STATE LEGISLATURE OF ILLINOIS, for example, has jurisdiction over the government of the counties, townships, cities, towns, and villages within the State. Local government is affected by local conditions, therefore, its form differs as local conditions differ.

forms with a multitude of elected officials.

New England States

The reader may live in New England. Here he will find the *town* and the *town meeting* the vital units of local government. The states of New England are divided into *counties*, but from the viewpoint of a citizen and his personal needs, the county is not of very great importance. In the New England States it is in the main simply a unit of judicial administration.

The town form of government—the vital local subdivision in New England—was developed by the early Colonists who lived in small compact settlements. It was a very democratic form of government in which all the freemen of the town shared. The town meeting, where everyone could individually express an opinion, was held several times a year. Later, as the town grew in size, a small committee known as *selectmen* was duly appointed to carry on the town's business between town meetings.

New England still retains this simple method of conducting town affairs. Town policies and laws in Massachusetts are still made by all the voters at town mass meetings. In addition to the selectmen, other officials are now elected, for example, a *town treasurer*, a *town clerk*, and a *school committee*, the *chief of police* and the *head of the fire department*. The *chairman of the board of selectmen* is the chief executive officer of the town. The New England town, which has the same general powers as a city but does not act under a charter, also does

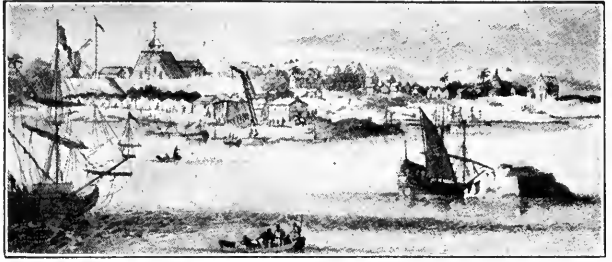

Local government in New England had its origin in the small, compact town. This is a picture of NEW AMSTERDAM, now New York City. A form of



local government that is suitable to a small section in the East would hardly meet the needs of THE GREAT FRUIT SECTIONS OF THE STATE OF CALIFORNIA, or the vast stretches of GRAZING

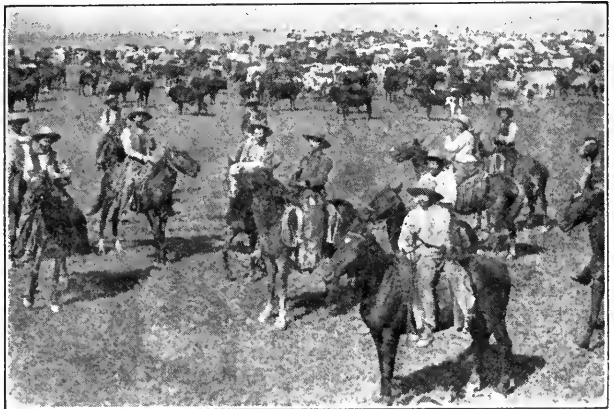

LANDS OF THE SOUTH WEST. Each section has a form of local government to meet its own needs.

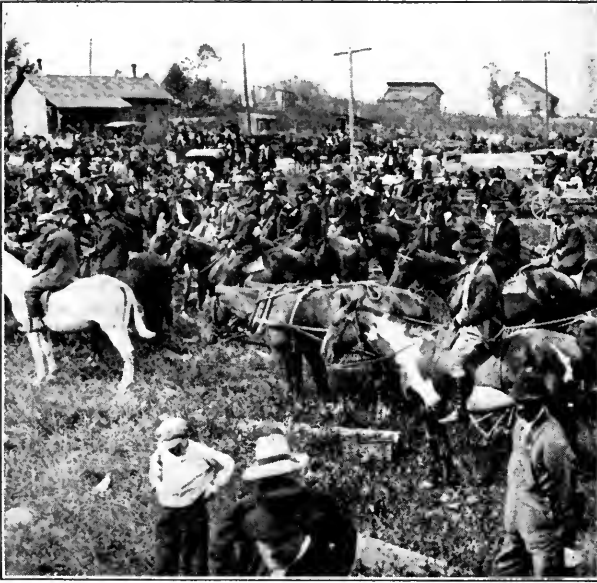

The HARDY MOUNTAINEERS OF KENTUCKY have developed different forms of local government from those found in New England and the Middle Atlantic States. This is true, also, of the form of



local government developed by the people of the Southeastern and COTTON GROWING STATES. There are over 3,000 counties in the United States, varying from a few square miles in area to Custer County, Montana, with its 20,175 square miles. Naturally, no general description of local government will cover exactly the organization of any particular locality—county, town or village, township, or city.

many things for the state government, such as *collection of state taxes, keeping records of births, deaths, marriages, land transfers, and administering state health laws.* It is also a district used for state and national elections.

South and West

The reader may live south of the *Mason and Dixon Line*, or in one of the *Far Western States*. Here the *county* and not the town becomes the most important local governmental unit. It is very natural that the New England town form of government has never been used in these less thickly settled parts of the United States except those occupied earlier by people from New England. In states like Michigan, the town meeting still survives, although the meetings are less often held and do less business. The county, naturally, covers a much larger area than the town. In the South, with its huge tobacco and cotton plantations spread over a wide territory, people are much more scattered, and the county is a much easier unit of government to use. This is also true of the vast stretches of land to be found in many of the Far Western States.

The county, however, is not confined alone to the South and the Far West. Every state in the Union, with the exception of *Louisiana*, where the corresponding unit is called a *parish*, is divided into counties. The county is universal, although more important in some parts of the country than in others. Altogether, in the United States, there are over 3000 counties,

varying in size from Bristol County, R. I., with its 25 square miles to San Bernardino County, California, covering thousands.

Importance of the County

The county is important for many things. It usually constructs and keeps in repair bridges and highways. The county almshouse and farm, and poor relief, are part of its welfare work and, in some cases, hospitals.

The county is also a very important unit of administration for the state, since it, in many places, looks after elections, selects polling places, appoints election officials and keeps a record of election results. It is usually a unit from which representatives are nominated and elected to one or both parts of a state legislature.

The county also acts for the state in administering criminal law, police matters, and in collecting taxes. The county court, the county judge, the county prosecutor, and, of course, when a conviction is made, the county jail, compose an important group of law enforcement agencies.

You record your will, or a deed of sale to a piece of property that you buy, or a mortgage on your house, in a county office. Many states use the local unit for the control of schools, with a county school superintendent in charge.

The reader will note that we have not stated that any one county does all of these things. The practice varies considerably in the different states.

Government of Counties

With the exception of Louisiana and Rhode Island, all coun-

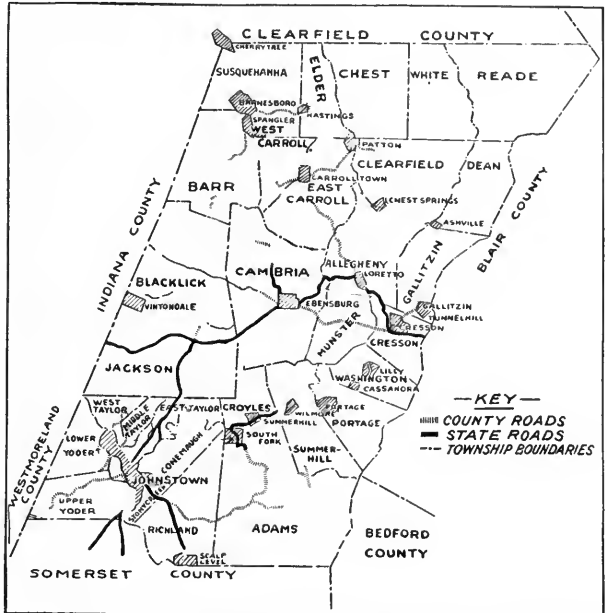

Each county in a state, as for example, CAMBRIA COUNTY, PENNSYLVANIA, is divided into townships. This map also shows the location of the towns



and villages in the county. It shows, too, how the State Government of Pennsylvania cooperates with the County Government of Cambria in the BUILDING OF GOOD ROADS. This is a very important work of both state and local governments. Good roads have done more than anything else to make farm life more attractive. This is especially true since the invention



of the automobile. The DRAINING OF MARSH LANDS within the county or township is another important function of local government.



Each County has a Court House in which the work of the County is done.

In a County Court House usually will be found the offices of the County Supervisors, County Sheriff, Prosecuting or District Attorney, Coroner, County Clerk, County Treasurer and the County Registrar.

Should you wish to record your will, or a deed of sale to some property, or a mortgage to your house, or pay your county taxes, you must go to the County Court House. A record of the births, marriages and deaths of the county is kept in the County Court House. In the County Court House **THE COUNTY COURT HOLDS ITS SESSIONS.** The County Courts are under the jurisdiction of the State.

ties are governed by a *board of supervisors* or *county commissioners*. These boards vary in size from as few as *three* to possibly as many as *fifty* members. The manner of their election also varies greatly as one goes from state to state. The county board of supervisors, or commissioners, usually has charge of the county poor farm, highways and bridges, poor relief, elections, and much miscellaneous work.

In addition to the county supervisors, there are many independent elected officers, among others a *county sheriff*, possibly the oldest and most important official, also a *prosecuting or district attorney*, a *coroner*, a *county clerk*, a *county treasurer*, and a *county registrar*.

Township Government

Instead of living in New England or the South, the reader may live in one of the Middle Atlantic States—New York, New Jersey or Pennsylvania—or in one of the Middle Western States of the Union. Here he will find that the county and the New England town form of government have been combined in what is often called the *mixed type* of local government—the *county-township plan*. The township, or town, in these sections of the United States is a subdivision of the county and of much less importance than it is in New England. Each township has its own *board of trustees*, or a *supervisor* and *town chairman*. It also has its *clerk*, *treasurer*, and *assessors*. In these states, often, the town supervisors, acting together, form the *county board of supervisors*

for the transaction of county business. In some states as Illinois, the town form prevails in one part of the state, the county in another.

In the Far West, the county, instead of being divided into townships, is usually cut up into districts called *precincts*. *School, judicial* and *road districts* are also used, but the county is the all important local unit.

Where the population in a part of a township or a county becomes thickly settled, there is generally a demand for a different kind of government, so that *streets, water supply, sewerage and lighting*, and other interests may be better looked after. A village, or a borough, or an incorporated town is then organized and incorporated under a general state law. Although by such act it receives the right to look after its own affairs, it still remains a part of the township, and county.

Village Government

Village government is very simple. Usually at a village meeting a *board of trustees* or a *council*, and a *village president* or *mayor* are elected by the qualified voters to look after village affairs. All questions regarding legislation and taxes are voted upon by popular vote at the village meeting. There are over 10,000 villages in the United States.

As a village grows larger and its needs become more complicated, it may be

chartered by the state as a *city* and be given a more adequate form of local government.

Other Forms

There are still other local government forms which should be mentioned, such as *school, judicial, road, sanitary, water control* and *fire control districts*. There are many others but it would take a chapter to mention them. The *school district* is probably the most important, as it is the most widespread and the one with which most rural inhabitants come into close contact and personal relationship.

School districts are formed for the purpose of *buying land, building schools, hiring and paying teachers, and levying school taxes*. Most school districts are in charge of a *school committee* or *board*.

Where the National Government touches the individual once, and the state government ten



THE VILLAGE OFFICERS OF DESLACS, NORTH DAKOTA, 1922: This is the first time in history that women have filled all political offices in a community. In the front row, left to right, are: The Chairman of the Board of Trustees; the Trustee, Third Ward; the Trustee, Second Ward; and the Treasurer. In the top row, the Justice of the Peace; the Marshal; the Clerk of the Village and the Assessor.

times, local government comes into contact with the individual in a hundred different ways. But usually the average citizen knows less about the details of his own community than he does about his state and national governments. But, nevertheless, *virile, efficient, and honest local government means everything to the happiness of the people and is the foundation upon which stands a strong state and nation*.



©The American Viewpoint Society

Drawing by Hanson Booth

THE AMERICAN CITY OF THE FUTURE

The location of future public buildings, transportation, generous park and playground space—these and many other needs will be planned far ahead

The American City

The American City Dweller Meets His Local Government and Its Services Every Hour of the Day

SMITH is the average American city dweller. He lives in a small house or rents a flat of six rooms. When he and his family get up in the morning, they wash with pure water supplied by the *City Water Department*. This water is often brought many miles in *aqueducts* and is provided in generous quantities and at small cost to Smith and his family, for drinking, cooking, and bathing.

The Smith family sits down to a breakfast cooked by gas or electricity, supplied by municipally owned *gas or electric light companies* or by private companies controlled by a *public service commission*. The *City Health Department* guarantees the milk used on the cereal at breakfast—its quality and its purity. After breakfast, the garbage is put in a can, later to be removed by the *City Street Cleaning Department*. Dish-water, instead of being thrown into the streets, as is still the custom in many backward countries, is carried away in *city built sewers*.

In some Oriental countries, where buzzards, dogs and other animals still constitute the sole scavenging department, and where there is little if any regard for sanitation, "*it is all right to have eyes*" some one has said, "*but it is a misfortune to have a nose.*"

Mr. Smith goes to his work on a trolley car, an elevated, or a subway train, and pays a fare which is fixed *by law*. If he works in a factory he is protected from unguarded machinery and carries on his occupation under conditions of health prescribed by law and enforced by *inspectors* of city and state. In case of fire, an efficient *City Fire Department* is

on the scene in a few minutes with its apparatus, ready to put out the fire, and, if need be, to save his life. If Smith is run over by an automobile, *traffic policemen* make a right of way for the *city ambulance* so that a *city doctor* may reach him as quickly as possible.

More Safeguards

Mr. Smith, instead of working in a factory, may be a clerk working in a ten, fifteen, or thirty story office building. Here, too, *city government* has thrown its safeguards around him. The skyscraper has been built according to building laws laid down by the *City Building Department*. The elevators which take him up and down are regularly inspected. The building may be furnished with automatic fire extinguishers required by *city ordinance*. Every step Smith takes throughout the day finds some city department, bureau or official assisting or protecting him.

The City Beautiful

AS a citizen, think of the future of your city. It is going to grow. Insist that your agents, the city officials, have a plan which will provide for future needs. Do everything possible to make your city beautiful, orderly, convenient. Never miss an opportunity to cast your vote for *good city government!*



THE MAN WHO LIVES IN A CITY meets his local government almost every minute of the day. The water in his home is supplied by the city. The

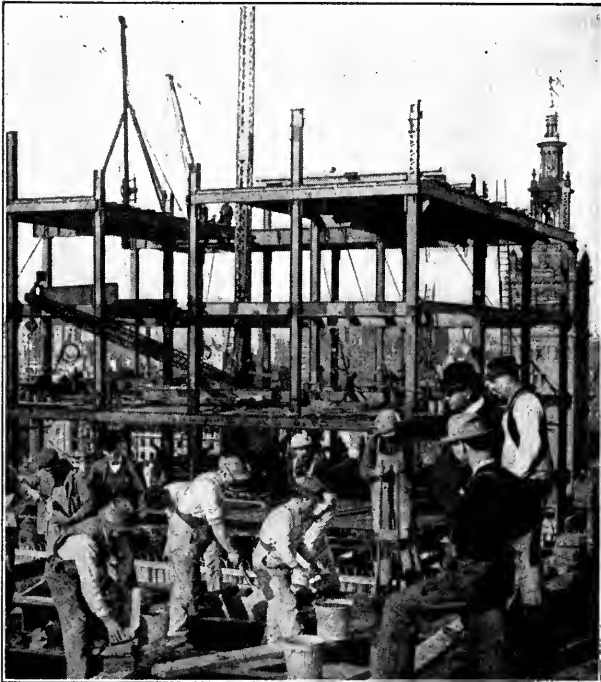

building in which he works—a shop, factory or a skyscraper with hundreds of offices—WAS BUILT ACCORDING TO THE BUILDING LAWS OF THE CITY and is at regular times examined by city officials to see that it is safe and kept in good condition.



THE STREETS of a city are built, kept in repair, cleaned, policed, and lighted by the city government.

Public Schools

Smith's children go to *school*. A special *traffic policeman* sees to it that they cross the busy streets in safety. The school building in which they study is built along modern lines; it is well lighted and fireproof. The teachers have passed *city examinations*, certifying to their fitness to teach. Doctors and nurses from the *City Department of Health* examine the children regularly and watch for signs of contagious diseases. Lunches, in some cities, are furnished to the pupils at cost.

Public Libraries

After school the children take advantage of the recreational facilities maintained at city expense. The oldest boy who is, perhaps, interested in *radio*, goes to the *public library* to read the latest magazines and books on the subject. The younger boy plays baseball in the *city park*, while the little one goes to a *neighborhood playground* in charge of an experienced playground teacher.

Mr. and Mrs. Smith and the family, on a winter's evening, go to a *free lecture* in the *school-house* or *community building*. On a summer's evening a *municipal band concert* may entertain them. As they go home, they walk along a street lighted by gas or *electricity*, paid for by city taxes. The American city dweller meets his local government and its services from the time he arises to the time he goes to bed. The *city policeman*, even while Smith and his family sleep, is patrolling his beat, and the city fireman is ready at a minute's notice to answer the clang of the fire bell.

Is it any wonder that every city dweller should take an active interest in his *municipal government*? Until one thus stops and catalogs his daily dependence upon the government of the city in which he lives, one has only a slight idea of its importance, and its many services to the people. "*City Government*," remarks a recent writer, "*touches more people at more points, and more frequently, than any other branch of government.*"



American cities have grown very rapidly in the last sixty years. Now over half the population of this country lives in cities. In 1860, the United States had JUST 26 CITIES WITH A POPULATION OF

Growth of American Cities

The most striking social fact of the last century is the amazing growth of American cities. A few figures will impress the rapidity of this growth on the mind of the reader.

In 1820, the U ited States had only a dozen towns with populations exceeding 8,000. Geography students in those days had little trouble naming all the American cities. Today, such a feat would be impossible. In the early days of the last century, only five per cent of all the people in this country lived in cities. Even as late as 1860, New York had just passed the million mark, while Chicago, with its 109,260 people, Detroit, with its 45,619, and Kansas City with its 4,418, were only at the threshold of their wonderful municipal careers.

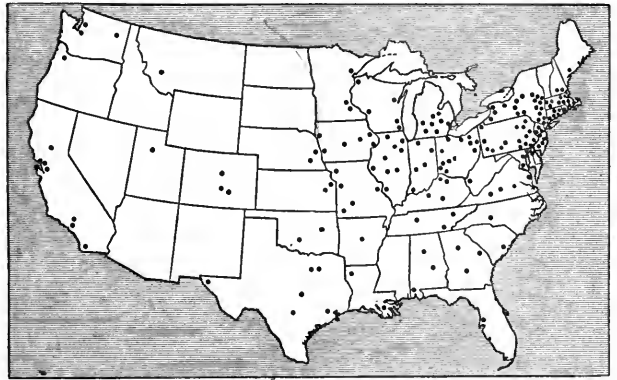

30,000 or over. Now there are over 100 with a POPULATION EXCEEDING 50,000. New York, alone, has a population of 5,620,000. Then comes Chicago with 2,701,705; Philadelphia, 1,823,779; Detroit, 993,678; Cleveland, 796,836; St. Louis, 773,000; Boston, 747,923; Baltimore, 733,826; and Pittsburgh, 588,193. That part of the United States which contains the

Look at them today! New York City, the leading city of the world, approaching the six million mark, Chicago, with 2,701,705, Detroit with almost a million, and Kansas City with 324,410! What a contrast these figures make with those of 1860!



One-tenth of the people of the United States today live in the

greatest number of cities and, naturally, that part that is the MOST DENSELY POPULATED, is shown on this map. The second most densely populated area in this country is the State of Illinois.

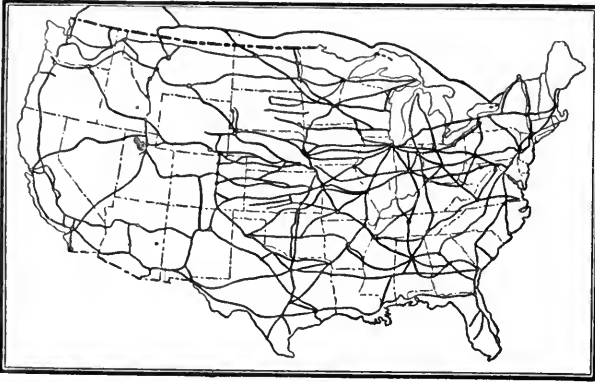

The growth of American cities is due to many causes. Railroads have greatly added to their development. Only **THE MAIN LINES OF THE RAILROADS** are shown on this map. Industries have also

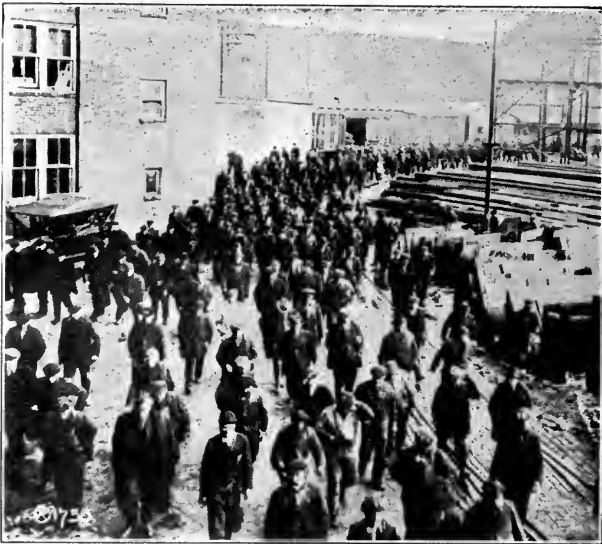

added to this growth. They constantly demand a large and increasing number of workers. The automobile has encouraged the building of good roads,

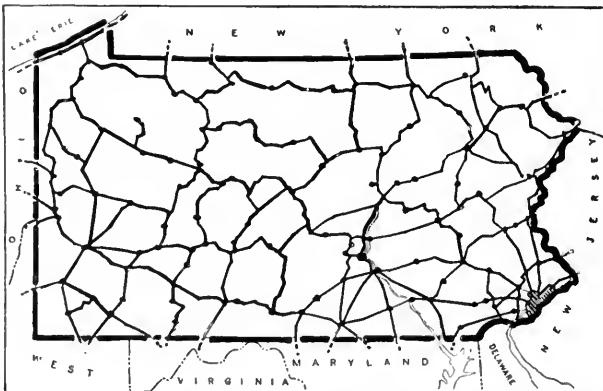

and good roads increase the size of cities by enabling the farmer to bring with ease his produce to the city. This map shows **THE GOOD ROAD SYSTEM OF THE STATE OF PENNSYLVANIA**.

cities of New York, Chicago and Philadelphia. *One-fourth* of all the people of this great country live in sixty-eight cities with populations of over one hundred thousand. The 1920 census, for the first time in this nation's history, brought out the startling fact that *more than half, 54,304,603, to be exact, of the American people live in cities of 2,500 and upwards.*

Reasons for Growth of Cities

This growth has its roots in many causes. The enormous development of factories, the vast extension of commerce, the amazing and rapid increase in transportation facilities—the railroad, the trolley, the motor truck, and the automobile—have all contributed. Modern agricultural machinery has made it possible for a relatively smaller country population to supply with food a relatively larger city population. There has been a steady drift of people from the country districts to the city within the last few decades. Immigrants, especially those who have come since 1880, have, to a large extent, remained in the cities and not gone on the farms. The result of these many causes has been to *cityfy* rapidly the United States.

This change, there is no doubt, is going to have many effects on American thought, social and economic life, and political institutions. Great municipalities have always been the nerve and the storm centers of civilization. The city dweller, in time, if this tendency from country to city continues, will gain political control. Municipal government, since over one-half of the American people now live in cities, must be carefully studied.

City Government Better

Until very recently, American cities have had a bad record for corruption, inefficiency, and waste. James Bryce, one of the keenest critics of our country, some years ago said that *the government of cities is the one conspicuous failure of the United States.*

But this has changed. *American cities, since 1900, have made tremendous progress in good government.* Although the *spoils system* has not entirely gone, the general introduction of *civil service standards* has greatly reduced its use. Voters have become more public spirited and much better informed. American cities have now begun to think in terms of progress.

The idea that a city is a business organization that should be run in the interests of its stockholders—the citizens—has made much headway. The passwords to good city government have now become *efficiency, responsibility, service, streets, sewers, transportation, parks, playgrounds, schools, health, safety, charities*—these are the business and social problems of the city, and upon their efficient handling city administrations must be judged.

What Is a City?

So far, we have not defined a city. "A city is a municipal corporation possessing power to sue and be sued, to acquire, hold, and dispose of property, to enact ordinances, to raise money by taxation, and to exercise the right of eminent domain."

This definition sounds very difficult, but it is not. It sim-

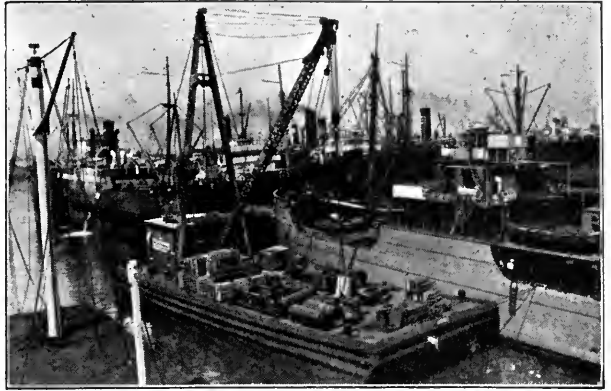

A city that is built near water will add to its population the many thousands who work on the docks and ships. This is a picture of A SECTION OF PHILADELPHIA'S GREAT WATER FRONT. The wonder-



ful LABOR SAVING MACHINES THAT THE FARMERS NOW USE to prepare the soil, plant, cultivate, gather and harvest the crops, add to the growth of cities, for one man with such improved



machinery can now do the work of many. IMMIGRATION IS ANOTHER REASON FOR THE GROWTH OF CITIES. Over eighty out of every hundred immigrants who come to this country settle in the cities.



A city is a business corporation. It can sue you or you can sue it. Should you receive an injury by falling into a hole in the street or sidewalk over which workers employed by the city had neglected to place a flag by day or a lantern by night, **YOU COULD SUE THE CITY.** If you do not pay your taxes, the



city can sue you. A city can make its own laws. **THESE LAWS ARE CALLED CITY ORDINANCES.**

ply states that a city is a business corporation which can sue you, or which you can sue; and just like other corporations, it can buy and sell property. It can make its own laws covering local matters, which, as has already been explained in Chapter 3, are called *ordinances*. A city can tax you, and it also can take your property for public purposes, for which, of course, it must pay.

The Authority of the State

All cities are, legally, the creations and the agents of *state governments*. Cities are absolutely under state legislative control, except where that control is limited by a *state constitution*. *The authority which any city has to carry on its work comes from a state.*

City Charters

The constitution of a municipality is its *charter*. It is granted to a city by the *state legislature* or under state law. A charter is the foundation of city government. It tells what officials a city may have, how they must be chosen, and what they may do.

Home Rule

Control by the state legislature has led to many conflicts over the right of a city to run its own affairs without constant interference on the part of a state. Who makes the city charter? What is to be put into a city charter? How may the charter be changed? These are vital questions which every state in the Union is attempting to answer.

State legislatures have often abused their power over cities. This control at times has greatly slowed up municipal progress;

and state or even federal *politics*, not the good of the city, in many cases have prevailed. Cities are in good part business corporations with certain governmental functions. Their citizens are to be considered the stockholders who mostly pay the bills. It is only fair and just that they control, as far as it is wise, the purse strings of their city government, and decide for themselves the kind of city government under which they wish to live. *Cities should have as much home rule as it is practicable to give them.*

State Authority Necessary

On the other hand, there is another side to the question of *home rule*. No city can live unto itself. Cities deal with many matters that are of wider concern than the municipality itself. Smallpox, for example, breaks out. Immediately the districts around the city, the state, even the Nation, have a concern in the manner in which the epidemic is handled, for smallpox spreads rapidly and if not quickly checked might affect the whole country.

No city can dispose of its sewage in such a manner as to endanger the health of another city. A city located at the head of a stream should not be allowed to dump its sewage into it in such a manner as to scatter disease to the cities and towns situated on the river below it.

New York City and Los Angeles go back miles into the mountains for their water supply. But other cities also are looking for water and must have similar privileges. The state, a higher authority, is the judge.



A city can condemn property and, at a fair price, secure it and use it for whatever purpose it may wish. An official of the city of Philadelphia is here shown beginning the work of TEARING DOWN PART OF A SLUM DISTRICT which that city turned into a beautiful park. This is known as the

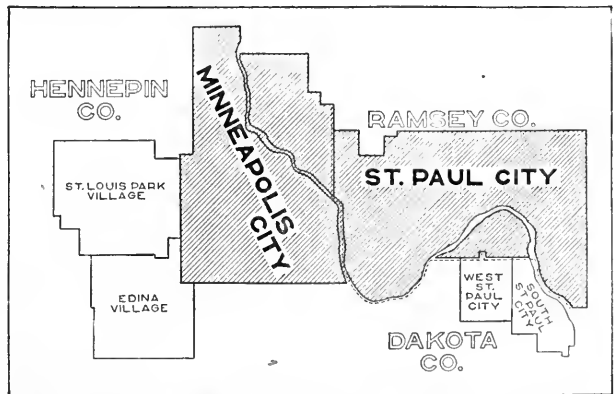

right of "eminent domain." The cities of Minneapolis and St. Paul have authority over THE TERRITORY THAT IS SHADED on this map.



The home of the government of a city is usually called the city hall. SAN FRANCISCO HAS ONE OF THE MOST BEAUTIFUL CITY HALLS IN THE UNITED STATES.

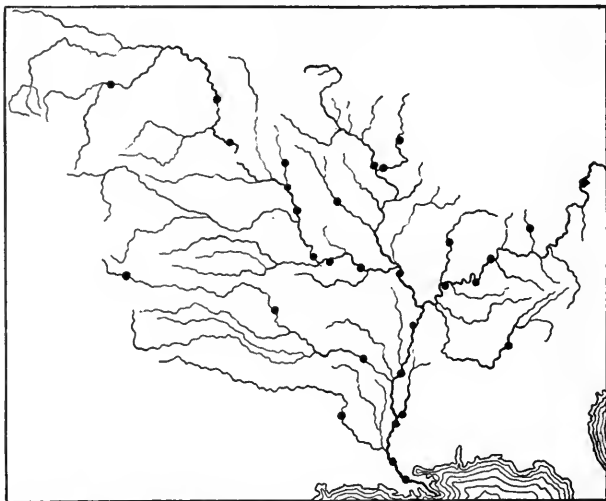

The government of a city is under the government of the state in which the city is located. This is right. A city bordering on THE MISSISSIPPI RIVER, or on one of its tributaries (see illustration), could not, for example, do what it wished with the river. In this case, each city (note dots) on this mighty waterway must consider the interests of all the other cities, hence, the need of state, even

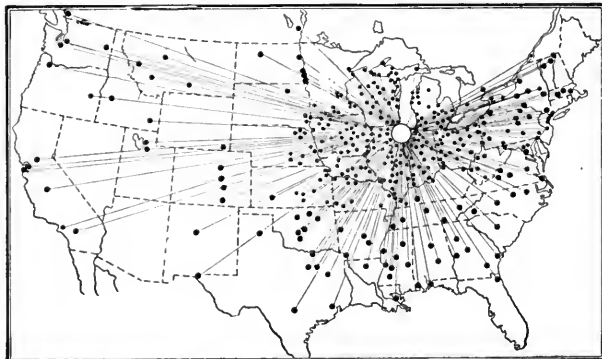

national supervision. Another example: Each day A FREIGHT TRAIN LOADED WITH FREIGHT LEAVES CHICAGO TO THE POINTS INDICATED ON THIS MAP. Here, again, millions of people who do not live in Chicago are interested in the transportation facilities of this great city. Here, again, the state and nation must step in. So important to a

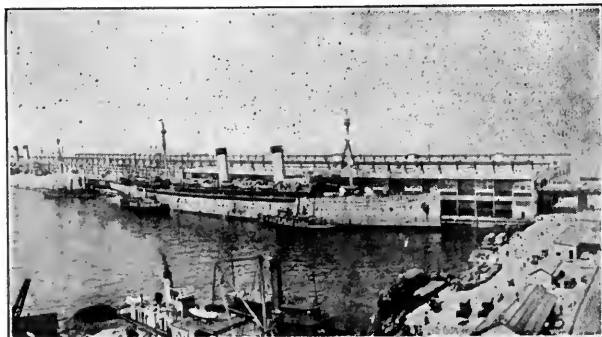

city is this one item of transportation, alone, that many cities are building their own docks. THE MUNICIPAL DOCKS OF GALVESTON, TEXAS, are shown.

Financial waste and extravagance in a great city may have a disastrous effect on other cities and on the state in which it is situated. Transportation facilities and their proper development are of as much concern to the truck farmers who desire to ship their vegetables to a neighboring city as they are to the city itself.

The development of great commercial centers, San Francisco, Chicago, New York, and Buffalo, is the concern of the whole nation, as well as of the citizens who live in those great cities. New York, for example, is the spout through which a large part of the whole trade of America must pass. New York is a national center, made what it is because a large portion of the gigantic wealth of the great United States goes through New York to its world destination. The world's products, in return are distributed from it, fan-shape-wise, to every hamlet and city in the United States. If high dock charges and inadequate shipping facilities are allowed to exist in New York, they have important evil results not only to the New Yorker, but to the State, to the Nation and to the World!

The proper relationships that should exist between city and state must be fixed on the basis of common sense and expediency which takes into consideration facts like these. Above all, the problem should not become merely a question of petty or party politics.

Kinds of City Government

Each State, as these facts indicate, is its own *municipal labo-*

ratory. Each city in America, at least in details, differs from other American cities. For these reasons, no statement which can be made about American municipalities in general will exactly describe the government of any particular American city.

The government of American cities falls into three general types. Everyone should have a working knowledge of them, their advantages and disadvantages. Many cities have, within recent years, changed their city governments entirely. Many more will do so within the next few years. As such changes are usually referred to the municipal electorate, every voter should have a clear idea of what he is asked to decide.

Mayor-Council Type

The Mayor-Council type of city government is the oldest. In this type the mayor is the chief executive and is aided by heads of departments such as the commissioners of police, fire, health, charities, correction and recreation, usually appointed by him. He carries out the ordinances passed by the city council or the board of aldermen which is the legislative part of the city machinery.

This council, or board, is usually elected on a ward basis; that is, a councillor or an alderman is elected from and represents a district in the city which is called a ward. The Mayor-Council type is the form of city government still generally used throughout the United States.

Power in this type of government has been gradually shifted from the city council or the board of aldermen to the mayor,

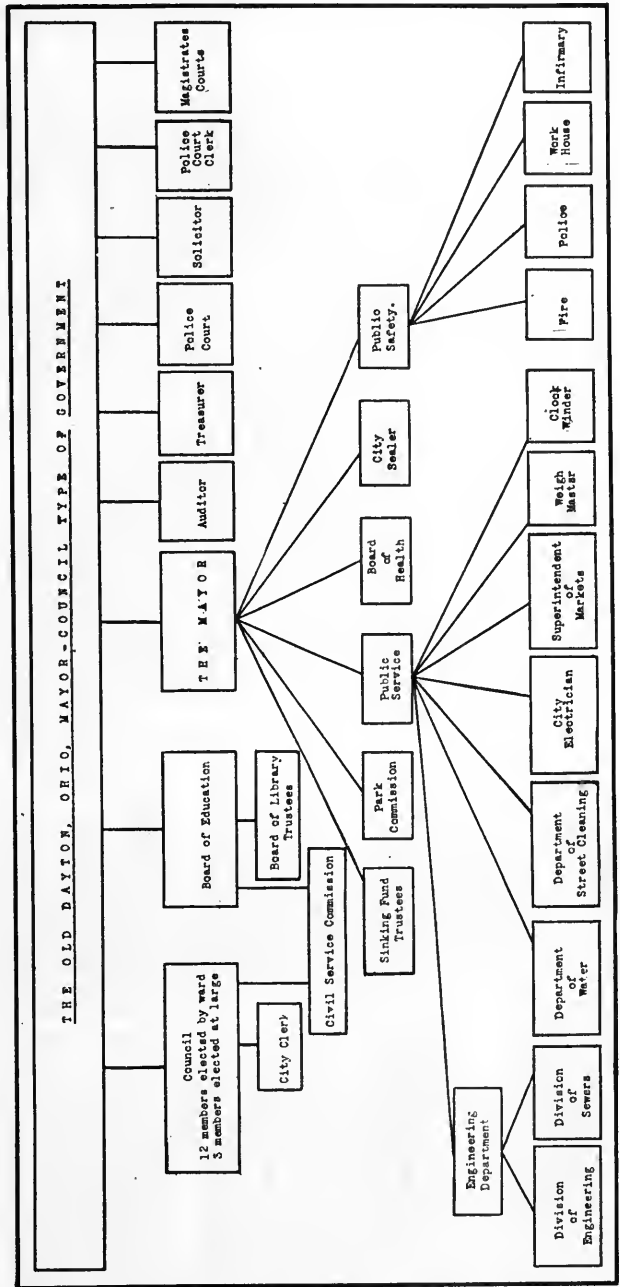

The greater number of cities in the United States are governed by THE MAYOR-COUNCIL TYPE OF GOVERNMENT. This chart illustrates this form of government. The people elect the Mayor and the members of the Council. The Mayor is the chief executive and appoints heads of departments. The Mayor also carries out the ordinances passed by the City Council or the Board of Aldermen.

Power in the Mayor-Council Type of City Government has been gradually shifted from the City Council or the Board of Aldermen to the Mayor. A Mayor who successfully governs a great city is often in line for the Governorship of his State.

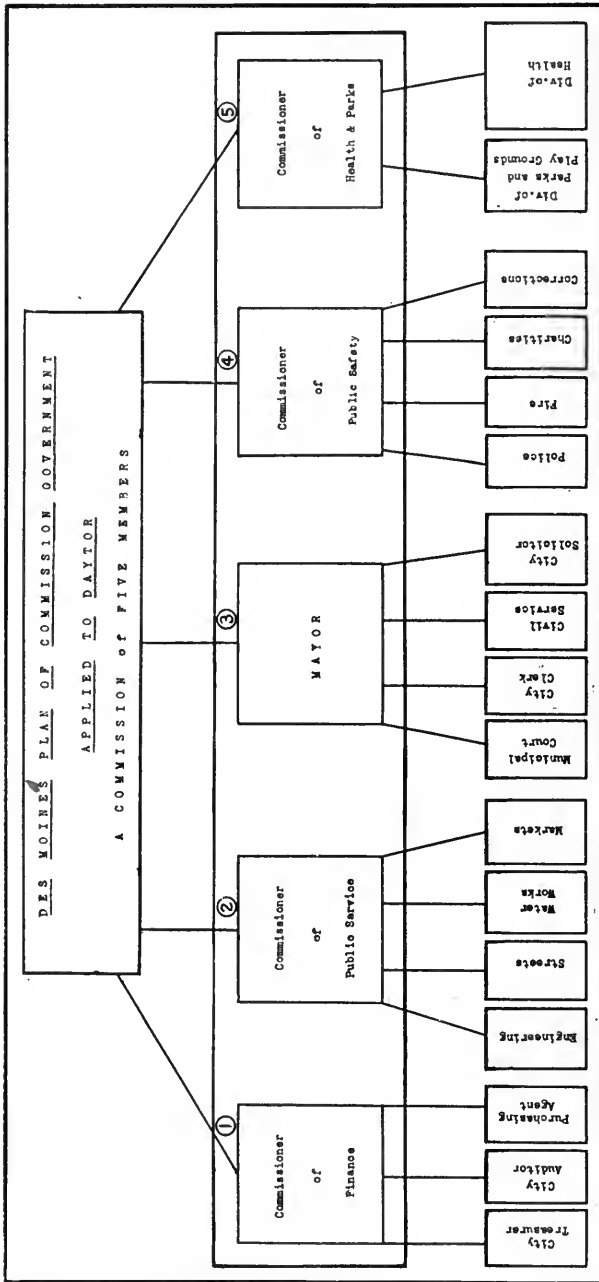

Many cities have adopted THE COMMISSION FORM OF GOVERNMENT. The chart illustrates this new plan of city government. The Commission puts the City Council and the Mayor in one body usually composed of five men. These five men pass all ordinances, make all appropriations, supervise and carry on the entire work of the city. By this plan, the Mayor becomes the nominal head and represents the city when important functions occur.

Many advantages are claimed for the Commission Form of Government by the cities which have adopted it. So far, however, only a few of the larger cities have adopted the plan; but among medium sized cities, the plan has spread very rapidly.

who is the outstanding and important figure.

The Commission Form

New standards have brought striking reforms. The most important has been the adoption of the *Commission form of city government*, first tried out by Galveston in 1901. This city, at the time, had the reputation of being one of the worst governed in America. There is an old saying, "*It is an ill wind that blows nobody good.*" The tidal wave and great storm that struck Galveston in 1900 was such an ill wind. It did great damage and nearly wiped out the city, but it gave, in return, a new type of government which has been copied in many parts of the United States.

In the reconstruction that followed the destruction of the city, the old city government was swept away, root and branch. A *commission of business men* carried on the city government as a temporary matter. Soon, the great merits of this centralized, responsible type of government were seen. Galveston petitioned the *Texas State Legislature* to be allowed to adopt the plan permanently. She was allowed to do so. Soon, the State Legislature allowed other cities of the State to take up the same system. Iowa followed Texas. Today the *Commission plan* has so spread that the cities using it can be counted by the hundreds.

How It Works

The *Commission plan* puts the powers and duties of the city council and the mayor, the legislature and the executive, into the hands of one body. This body

usually consists of *five men*, although the number may vary. *These five men pass all ordinances, make all appropriations, supervise and carry on the entire work of the city.* The work of running the city is distributed among the members of the commission according to their own wishes. One commissioner may look after *public affairs*, another, after *accounts and finance*, another, after *public safety*. One may look after *streets and public improvements*, and the last after *health and charities*.

The scheme practically abolishes the office of mayor as it is found in the Mayor-Council type. A mayor is usually elected, however, so that the city may have a nominal head to represent it upon important occasions. He sits as a member and formal chairman of the commission but has no greater powers than the other members.

Each commissioner is held responsible for the efficient running of his own department. The entire commission is held responsible for the city government as a whole.

Advantages

Many advantages are claimed for the *Commission form of government* by the cities which have adopted it. In the first place, it puts responsibility in the hands of a small group of men. The voters thus know those whom they should blame for shortcomings. Better men, experience seems to show, are attracted to public office by the increased authority and responsibility that the Commission form gives to them. Moreover, the governmental structure is greatly

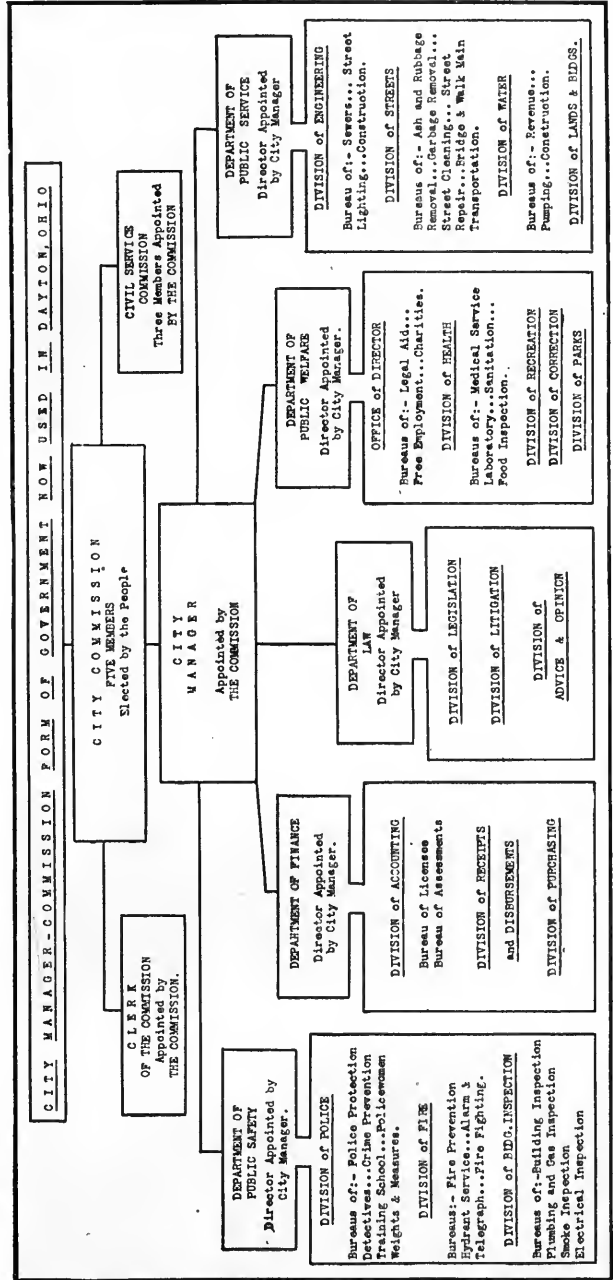

There is yet another plan of city government. This is called THE CITY MANAGER PLAN. It is, as the chart shows, like the Commission plan with the addition of a City Manager.

This Manager can be compared to the general manager of a business corporation or to the superintendent of a factory. The City Manager is hired by the Commission and is chosen because of his special fitness for the work. He is a trained public official whose job it is to take charge of a city government. It is a new profession. Some universities even are training men for this particular line of service. The City Manager Plan is now used in over 200 cities in America, but, like the Commission Form of Government, only medium sized cities have as yet adopted it.



Every city carries on five great groups of services: In the first place a city protects life and property. One of the most important departments of a city is **THE POLICE DEPARTMENT**. Many cities send their police in cars to patrol the suburban districts. The second public safety depart-

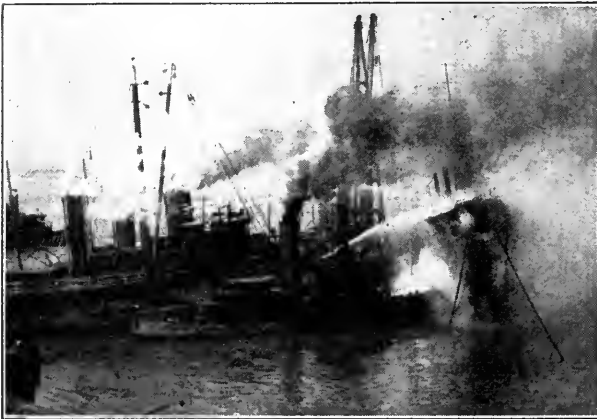

ment is **THE FIRE DEPARTMENT**. If a city borders a river it maintains a fleet of powerful fire boats.



Another great group of services that a city gives comes under the general name of "public works." Building streets and sidewalks and keeping them in repair is work that belongs to this department.

simplified and business is more efficiently carried on. There is less friction between antagonistic parts of the government. Less time is lost in useless discussion, so often the bad habit of a city council. It seems to be a more business-like arrangement for the kind of work that cities have to do.

So far, however, only a few of the large cities have adopted the plan. They still retain the Mayor-Council type of government, but among smaller cities, especially the medium sized cities, the plan has spread rapidly.

Des Moines, Iowa, and other cities, have combined more radical measures with the Commission plan, such as the *initiative*, the *referendum* and the *recall*. Two of the most interesting measures adopted by these, and other cities, are the doing away with the party emblems on the ballots used in municipal elections, and the use of an *open, non-partisan primary* in making nominations for office.

City Manager

Many cities have added another feature to the Commission—the *city manager*. Cities which have adopted this plan are usually said to have the *City Manager type of government* although it is more correct to say *the Commission City-Manager plan*.

The city manager is an expert superintendent of city affairs. He can be compared to the general manager of a business corporation, or to the superintendent of a factory. He is generally appointed for an indefinite time by the commissioners, and is responsible to, and removable by

them. He is usually paid a good salary.

The city manager does away with one of the difficulties which has been brought out by experience with the Commission form of government. The commissioners are not usually experts in any one special line of municipal administration.

When a commissioner takes charge of the police department, or of health, or of charities, he is very often not fitted to do the work. *The city manager, however, is a trained public official, whose job it is to take charge of a city government and its activities.* It is a new profession. Some universities, even, are training men for this particular line of service. A city manager is now used in over 200 cities in America, but, like the Commission plan of government, this form has made rapid headway only in the smaller cities.

Services Given

We have described the importance, the growth of the American city, and its government. Only indirectly has anything been said about what it does. These tasks are just as important as the form of the government of a city, and both are closely related. The machinery of government is no more than a means to an end. That end is *service to the citizen.*

It is confusing to attempt to catalog these services, they are so many. It is helpful, however, to boil them down to *five great groups of services* which every city carries on.

Public Safety Departments

In the first place, a *city protects life and property.* Here are

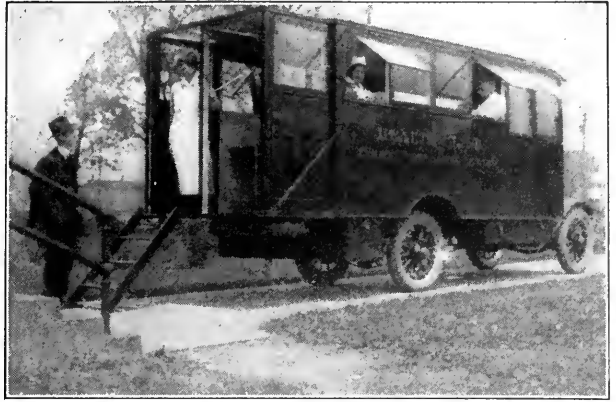

The city, in the next place, does many things for the welfare of its citizens. It maintains city hospitals, and in the larger cities "hospitals on wheels" with doctors and nurses go to the homes of the people in distress. The poor are also looked after by the city.



CITY CHARITIES AND LODGING HOUSES are maintained for the homeless. The fourth great task of the city is Education. It is interesting to note how fully the American Public School system is developed



in the cities and towns of our newly acquired Territories. This is a picture of Hawaiian children entering a public school in Honolulu.

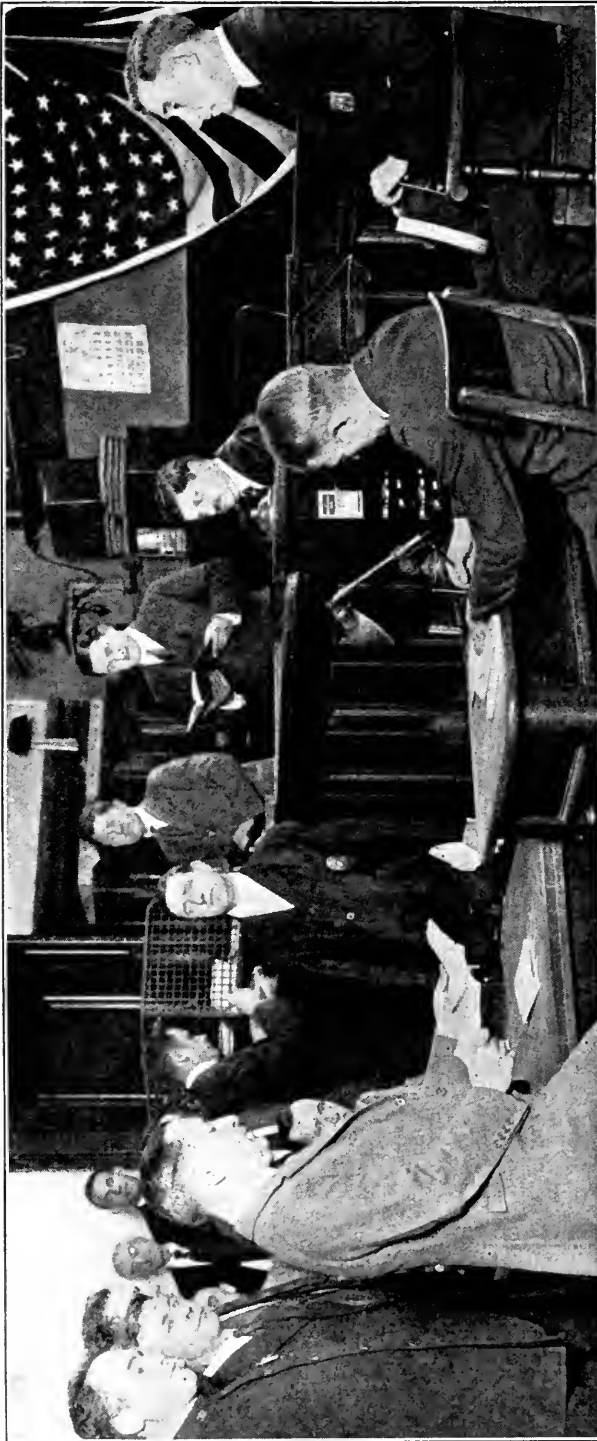

Cities, in many cases by state permission and authorization, have their own courts. This picture shows the WEST SIDE COURT, NEW YORK CITY, said to be the busiest magistrate's court in the United States. Here may be seen the judge, the prosecuting attorney who is reading the warrant, the detectives, clerk of the court, etc. The prisoner is behind the policeman and detective at the left.

found those great public safety departments, such as *police, fire, corrections and health.*

Public Works

In the second place, a *municipality looks after many public works*, such as the making of streets, erecting public buildings, laying sewers and the like.

Welfare Departments

A city, in the third place, *does many things for the personal welfare of its citizens.* All cities make provisions for the relief of the poor, the sheltering of the homeless, the care of the sick, homes for the old, and other like activities.

Education—Finance

The fourth great task—*education*—is apparent to all. The fifth and last, *finance*, is ordinarily given little attention by the citizen except when he is presented with his tax bill. Individual cities spend millions—hundreds of millions—of dollars. The budgets of New York, Philadelphia and Chicago are greater than the entire expenditures of some independent nations. Good bookkeeping, it is often and truly said, is the first essential to the success of any business. Sound accounting is just as important to a city.

Citizen's Responsibility Great

This multitude of services, the vast army of civil servants needed to carry them on, and the very rapidity of growth of American cities, place a heavy responsibility on the municipal citizens, and those whom they elect to office. Above all, every voter should have a clear idea of the government of his city, its form and its functions.

Many of the present problems, the defects which we are trying to do away with today, can be traced to a lack of vision on the part of those responsible. People—city administrators—have not looked far enough ahead. They have not thought of their duty in terms of progress. The consequence has been that most cities in the United States in the past have grown up much like *Topsy*, with little care and without much planning for the future.

The location of future public buildings, transportation, needs of an increasing population, automobile and street traffic, adequate planning for sewage disposal, generous park and playground space—these and many other needs should be planned far ahead. Otherwise, millions of dollars will later have to be spent for improvements and advantages

which would only cost a small fraction if arranged for beforehand.

Washington, the Capital of America, with its convenient arrangement, its broad streets and its excellent and well planned locations of public buildings, is a fine example of city planning. Cleveland, in this respect, is looking far ahead, as are also the cities of Toledo, Minneapolis, San Francisco, Chicago, New York, and many others.

As a citizen, think of the future of the city in which you live. It is going to grow. Insist that your agents, the *city officials*, have a plan which will provide for future needs. Do everything possible on your own part to make your city beautiful, orderly, convenient. Never miss an opportunity to cast your vote for *good city government!*

“WE WILL NEVER BRING DISGRACE TO THIS, OUR CITY, BY ANY ACT OF DISHONESTY OR COWARDICE; WE WILL FIGHT FOR THE IDEALS AND SACRED THINGS OF THE CITY, BOTH ALONE AND WITH MANY. WE WILL REVERE AND OBEY THE CITY’S LAWS AND DO OUR BEST TO INCITE A LIKE RESPECT AND REVERENCE TO THOSE ABOVE US WHO ARE PRONE TO ANNUL OR SET THEM AT NAUGHT. WE WILL STRIVE UNCEASINGLY TO QUICKEN THE PUBLIC’S SENSE OF CIVIC DUTY. THUS, IN ALL THESE WAYS, WE WILL MAKE THIS OUR BELOVED CITY NOT LESS, BUT GREATER, BETTER, AND MORE BEAUTIFUL THAN IT WAS BEFORE US.”—*The Oath Taken by the Boys of Old Athens.*

✦ ✦ ✦

“Cities, indeed, have been the cradles of human liberty.”—*Guthrie.*

✦ ✦ ✦

“A city is well governed when the people obey the magistrates and the magistrates the law.”—*Solon.*

✦ ✦ ✦

“When a man assumes a public trust, he should consider himself as public property.”—*Jefferson.*

✦ ✦ ✦

“In order to succeed, we need leaders who can kindle the people with the fire from their own burning souls.”—*Roosevelt.*

✦ ✦ ✦

“The very essence of a free government consists in considering offices as public trusts, bestowed for the good of the country, not for the benefit of an individual or a party.”—*Andrew Jackson.*



©The American Viewpoint Society

Drawing by Hanson Booth

AN IMPORTANT TASK FOR THE SCHOOLS

The American electorate must be prepared to meet its international problems wisely. . . . The schools must bear most of this burden of preparation.

America—A World Nation

The Spanish-American War Brought to Us the Problem of Governing Territories Peopled by Races Alien in Speech and Customs

ONE OF THE MOST IMPORTANT PROVISIONS in the National Constitution has still to be discussed. This clause reads: "*Congress shall have power to dispose of and make all needful rules and regulations respecting the territory or other property of the United States.*"

Under this wise provision, the rapid territorial expansion of the United States has taken place. It has enabled America to grow from *thirteen original states* straggling along the Atlantic seaboard to a gigantic nation extending from the Atlantic to the Pacific, from the Canadian border to the Rio Grande, and reaching out to many distant possessions — *Alaska, Hawaii, the Philippines, the Panama Canal Zone, Porto Rico, American Samoa, Guam, and the Virgin Islands.*

Government of Territories

The Spanish-American War, in 1898, suddenly brought the United States face to face with the problem of governing territorial possessions peopled by races alien to us in speech and customs and unfamiliar with American institutions. The war closed with the American flag flying over the Philippines, Porto Rico and Guam. The annexation of Hawaii, which also took place in 1898; the acquisition of the Panama Canal Zone in

1904, and of the Virgin Islands in 1917, gave this nation many new perplexing questions of colonial administration to solve. Congress, by virtue of its authority under the constitutional provision just quoted, has met these problems by the passage of a series of "*organic acts*" which provide for the government of these territories and dependencies.

These acts are the fundamental laws, *the constitutions*, so to speak, of the insular possessions of the United States.

The Hawaiian Islands

Congress established a territorial government for these mid-Pacific islands in 1900. Under the provisions of this act, the Federal Government at Washington operates directly such services as the *post office, the collection of customs, coinage, and the regulation of national banking;*

while all local matters are looked after by the local Hawaiian government.

This local government consists of a *Governor* appointed by the *President of the United States* with the consent of the *United States Senate*, and a *Territorial Legislature* made up of *two houses*, a *Senate* with fifteen members, and a *House of Representatives* with thirty members. Hawaii also has the right to send one *delegate* to the Na-

The Monroe Doctrine

"* * * **T**HE American Continents * * * are henceforth not to be considered as subjects for future colonization by any European Powers * * * therefore, * * * we (The United States) should consider any attempt on their part to extend their system to any portion of this hemisphere as dangerous to our peace and safety."

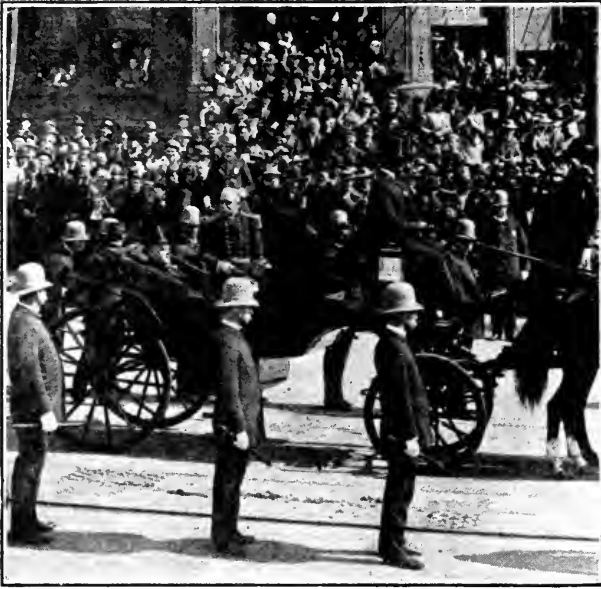

During the Spanish-American War, 1898, the American Flag was raised in the Islands of the Pacific. THE HERO OF THIS WAR WAS ADMIRAL DEWEY, who, upon his return, received the thanks of Congress and President McKinley, and also the applause of the citizens of the whole country.

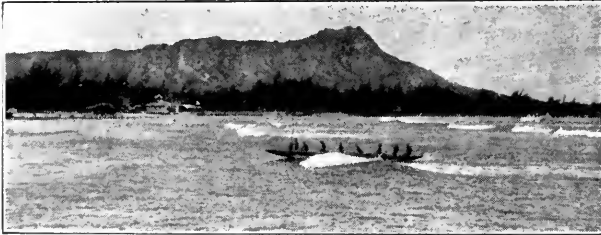

In 1898, the United States annexed Hawaii and organized these Islands into a territory in 1900. The approach to Honolulu, the capital city, is strongly fortified. The government FORTIFICATIONS ARE BUILT ON THE TOP OF A GREAT MOUNTAIN.



Fishing is one of the chief industries of the natives of these Islands. Honolulu HAS MANY GREAT FISH MARKETS.

tional House of Representatives at Washington. This delegate, however, cannot vote in that body. All citizens of these islands at the time of annexation in 1898, became citizens of the United States.

The Philippine Islands

This very important group of islands, our outpost in the Far East, is now governed under a *Congressional Act passed in 1916*. The *Philippine Legislature*, which looks after local matters, consists of two houses, a *Senate* of twenty-four members and a *House of Representatives* of ninety members. This legislature sends *two resident commissioners* to the House of Representatives of the United States, but, as in the case of Hawaii, these delegates have not the right to vote.

The executive head of the Philippine Islands is a *Governor-General* appointed by the President of the United States with the consent of the United States Senate. He has the right to veto bills passed by the local Filipino Congress. Vetoed bills cannot be passed over the Governor-General's head without the consent of the President of the United States. This provision gives the President a check on all Filipino legislation.

Pledge of Independence

The Act of 1916 contains a pledge to give the Philippines Independence when the right time comes. Independence naturally depends upon the ability shown by the Filipinos to govern themselves, on the educational progress which they make, and on the international situa-

tion as it affects the strategic importance of these islands.

The Filipinos are not citizens of the United States as are the people of Hawaii and Alaska. The provisions of the National Constitution of the United States have not been extended to them. Internationally, however, the American Government will protect them and see that their rights abroad are respected to the utmost.

In this respect a Filipino to all intents and purposes is an American citizen. He is, however, generally called a "national" of the United States, to distinguish him from a full-fledged citizen.

Porto Rico

Porto Rico was acquired by the United States in 1898 as the result of the *Treaty of Paris*, which terminated the Spanish-American War.

The government of this West Indian island is very similar to that of the Philippines. A *Governor-General* is appointed in the same manner and with the same powers. With the assistance of an *Advisory Executive Council* of six members, he is at the head of the island's administration. The *Legislature* consists of two houses, a *Senate* with nineteen members and a *House of Representatives* with thirty-nine members.

Porto Rico sends to the Federal House of Representatives one delegate who, as in the other possessions, has no right to vote. In local affairs Congress has interfered very little with Porto Rico, and the island, in consequence, has had a full measure of *home rule*.

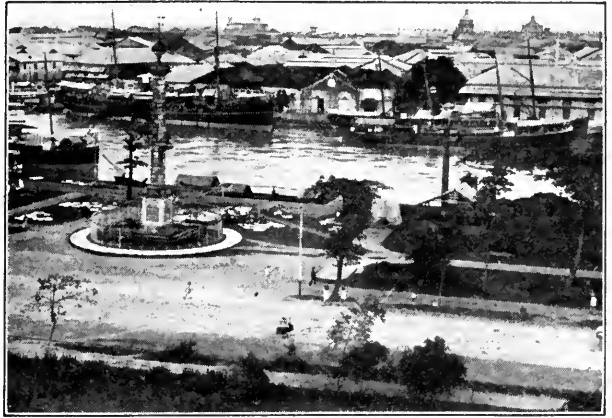

The Philippine Islands were acquired in 1898 as a result of the Spanish-American War. They embrace over 3,000 islands and have a total area of 150,026 square miles. Their population is over 9,000,000. MANILA IS THE CHIEF CITY, a view of which is

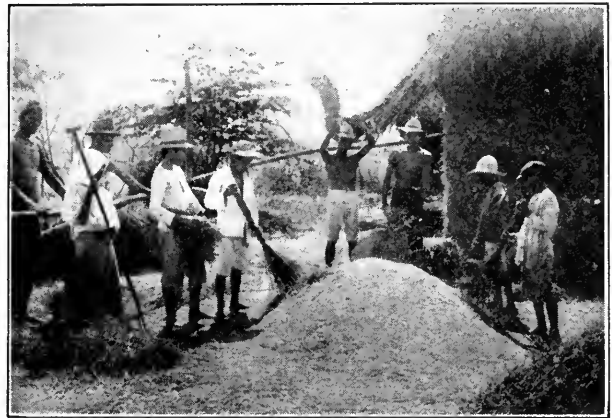

here shown. Before these islands were acquired by the United States, primitive methods were employed in all industries. The picture shows NATIVES THRASHING RICE by the old hand method. Up-to-



date farm machinery is now generally used. THE GROWING OF SUGAR CANE is one of the chief industries of these islands. This industry has tripled in the last 12 years.



Porto Rico was also acquired by the United States as a result of the Spanish-American War. San Juan is the chief city of this island and its Capital. A STREET SCENE of this city is here shown.



Sugar cane is grown in great abundance on this island, and a great deal of SUGAR IS ANNUALLY SHIPPED FROM SAN JUAN to the United States.

Samoa, Guam, The Virgin Islands, and Panama Canal Zone

Samoa and Guam are both governed by a *naval officer* appointed by the Secretary of the Navy of the United States. These islands are under the control of this Department. The Virgin Islands are temporarily in charge of the Navy Department. The Panama Canal Zone has a *Governor* appointed by the War Department to look after its affairs.

Alaska

Alaska, the oldest and most important of our possessions, was purchased from Russia in 1867. It is a territory of the United States, controlled by a *Governor* who is appointed by the President and by an *Alaskan legislature* which passes local laws.

Owing to its small population and to the vast territory which this country covers, many matters are looked after directly by the *Executive Department* in Washington. Education, for example, is under the direction of the *Department of the Interior*. Alaska sends one delegate, without the right to vote, to the House of Representatives.

The District of Columbia

Just a word should be said about the *District of Columbia*, known to most of us as the City of Washington. This territory, set aside as the seat of the National Government, is under the absolute control of Congress. Its affairs are looked after by a *commission of three* appointed by the President, while all the laws affecting the District, must

be passed by Congress. Permanent residents of the District have no vote. The cost of the government of Washington is divided, ^{40%} one-half being paid by the National Government, the ^{60%} other half by local taxes.

[Our Territorial Policy

The American territorial policy has been based on the betterment and advancement of its territories and possessions. Cuba, for example, occupied by us during the Spanish-American War, was later returned, although America still extends its protection to this island. Everything possible has been done to raise the level of education and of government in our possessions. In the Philippines we have introduced a *complete and up-to-date school system*.

The form of government and the laws of the United States have been introduced in the territories, and in most cases the rights and the privileges of the United States Constitution have been extended to the people. Local government, *home rule*, has been introduced as rapidly as possible. The natives of most of these possessions now have their own local legislatures.

A World Nation

The raising of the American Flag in these insular possessions has done a great deal to bring us into close contact with a number of other nations. As our Flag has crossed the Pacific it has brought us face to face with the great Oriental nations of China and Japan. Our part in the World War brought us into immediate contact with many



The Panama Canal Zone includes all the land for five miles on each side of the center line of the route of the Panama Canal. This is practically **THE ONLY TERRITORY UNDER THE AMERICAN FLAG THAT GROWS BANANAS**. American Samoa was

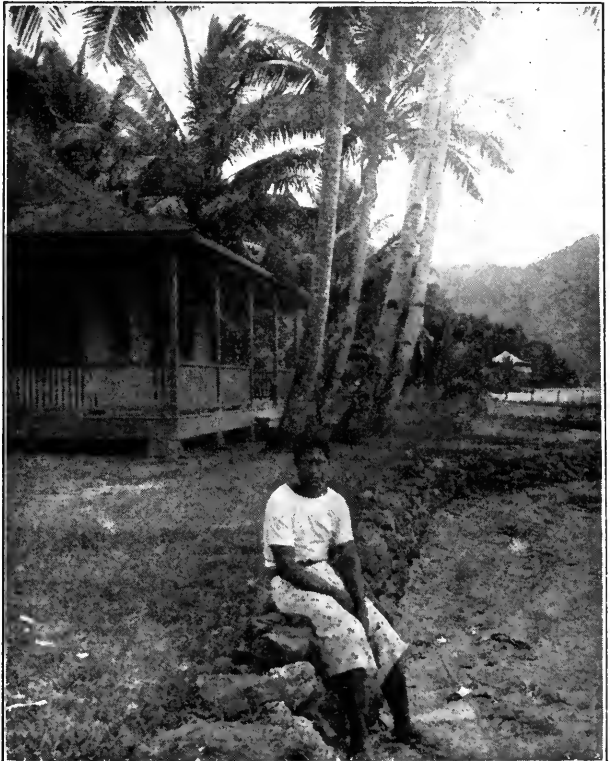

acquired by the United States in 1900 as the result of a treaty with Great Britain and Germany. Pago Pago is its chief city and the seat of Government. The picture shows **A SCENE ON THE WATER FRONT AT SAMOA'S LITTLE CAPITAL**.



Alaska was bought from Russia in 1867 for \$7,200,000. Since that date it has produced furs exceeding in value \$100,000,000; minerals—gold, copper and silver—\$425,000,000. Its annual fishery products yearly exceed in value \$50,000,000. But this is not the whole story of Alaska's wonderful wealth and opportunities. Annually, nearly a million dollars worth of products of the soil are produced. THE ACREAGE PLANTED IN WHEAT IS YEARLY INCREASING. The native population is composed of



Indians and Eskimos. Fishing, hunting and, more particularly, the raising of herds of reindeer, are the chief occupation of the natives. In the picture will be noted A ROW OF CURIOUSLY CARVED TOTEM POLES. The carvings depict animals. These, the work of the natives, have a religious significance.

other nations. Today when we speak of the American foreign policy we think of the whole world; whereas, only a few years ago when anyone in the United States spoke of the American foreign policy he thought only of our *South American neighbors* and the *Monroe Doctrine*.

The cable, the radio, improved ocean transportation, the expansion of foreign trade, newspapers and press associations have all contributed in bringing the nations of the world into closer contact.

International Problems

It is not within the province of this book to discuss or advocate any particular *international policy*. It is, however, within its scope to emphasize the fact that in the future such questions will become more and more important to the people of the United States, and that every citizen will be called upon to discuss foreign affairs and to place in office men who will understand them and pass intelligently on them.

The American electorate must be prepared to meet these international problems wisely and with a true realization of the economic, racial and political factors involved. It is a great responsibility. It means that to solve such matters wisely America must have citizens who know not only their own government thoroughly but also its political and industrial history; who know something of other nations, who have a grasp of economics and some idea at least of the importance of the great racial questions which stand in the forefront of the world's problems.

This is placing a heavy burden on the average American citizen; but citizenship in the American democracy in these troublesome days means a heavy responsibility. *Education—Education—Education*—must be the motto of the United States. The schools naturally must bear most of this burden.

Many think that the schools exist to prepare people to earn more money. This

is important but only incidental. *The real job of the schools is to make better, wiser, more patriotic American citizens.* America—every democracy in fact—*must be built on its schools*, since an educated and self-controlled electorate is the foundation upon which a **REPUBLIC**, above all other forms of government, rests for its very existence.



©N. Y. World

Drawing by W. J. Enright

AN EXAMPLE FOR THE WORLD

"At the recent Conference on the Limitation of Armaments held at Washington, no single aspect of international relations attracted more attention than the unfortified frontier of from three to four thousand miles between the United States and the Dominion of Canada. * * * Here no forts threaten, no bombs are planted, no poison-gas projectors are concealed, no navy yards clang with the making of war machines, no cannon lie in wait. No airplanes search out hidden strongholds, no submarines explore the clear waters of these lakes. There is no army and no navy; best of all, there is the hundred-year habit that prevents the people from feeling the need of either or even wondering why they do not exist. * * * As the matter stands, the Canadian boundary-line is the world's finest example of common sense applied to exorcising the nightmare menace of war."—N. Y. World.

Questions and Problems Based on the Text

If You Can Answer Correctly the Following Questions, You Have the Right to Say, "I Know the Main Facts and Fundamental Principles Regarding the Government of the United States"

CHAPTER I—WE, THE PEOPLE

1. Estimate the number of people who had a part in providing the material for, and in making and selling the pair of shoes that you are wearing. (Page 9)
2. Why is confidence in, and cooperation with one another necessary in modern life? Give five examples of your dependence upon the honesty and good intentions of your neighbors. To how many people do you trust your life when you ride in a train? (Page 13)
3. Why is a policeman needed to keep order among people who mean well? Name other duties of a policeman. (Page 15)
4. Name five ways in which the government—local, state or National—helps you to save your time. (Page 17)
5. Can you repeat the preamble to the Constitution of the United States? This preamble is thought to contain one of the best statements of the purposes of government to be found in any document. What are these purposes? (Page 20)
6. What does the word "American" mean to you? Why is the character of the people of a nation even more important than its rich natural resources? (Page 22)

CHAPTER II—THE MECHANICS OF GOVERNMENT

1. What are the three most important tests of a democracy? Apply those tests to the United States. (Page 26)
2. To how many different kinds of government are you responsible? Name two officials of each kind. (Pages 27, 28, 29)
3. Why should not the government of a state instead of the National Government handle questions which come up in connection with other countries? (Page 30)
4. Why is the government our agent? Into what three main divisions do we group the people who represent us in the Government? In what division is the Governor of your state? The Chief Justice of the United States Supreme Court? The Mayor of your city? Your state Senator? Your city Councilman or Alderman? The President of the United States? (Pages 31, 32, 33)
5. Is it our duty to assist the Government to enforce the Prohibition Amendment to the Constitution even though we may dislike this particular law? Give full reasons for your answer. (Page 33)

CHAPTER III—LAW AND GOVERNMENT

1. Why are rules and umpires necessary in a baseball game? In what respect can you compare the laws of the Nation with the rules of a baseball game? Is it right for an individual player in a baseball game to break a rule of the game if he thinks the rule unfair? Why? (Page 35)
2. What advantage is it to an immigrant to this country to adopt and respect the customs of the United States? (Page 36)
3. Why do people in the United States think so much of the Constitution? Why would it be wrong and harmful to change this Constitution without a great deal of thought on the part of the people? (Pages 39, 40)
4. What is a law? Explain the difference between a constitutional law and a statutory law. What is an ordinance? What is the difference between the Prohibition Amendment and a law against spitting on the sidewalk? (Pages 40, 41, 42)

5. Name five new laws which you would like to see passed, including an Amendment to the Constitution of the United States. Name three existing National laws, three State laws and three local ordinances. (Page 43)
6. Where do new laws come from? (Page 43)
7. If a person is arrested and accused of committing a crime, what constitutional rights may he demand? (Page 44)
8. If a driver runs an automobile without a license, and, exceeding the speed limit, injures someone, what two kinds of law is he subject to? (Page 45)

CHAPTER IV—THE CONSTITUTION OF THE UNITED STATES

1. Why is it so difficult to get a new nation started? Illustrate your answer from some of the present day infant states, such as,—Hungary, Poland, or any other you may think of. (Page 47)
2. Trace the events that led up to the making of the Constitution of the United States. Why has this period been called "the critical period of American History"? (Pages 48, 49, 50)
3. Who was our first President? When and where was he inaugurated? (Page 50)
4. To how many people did the Constitution apply when it was first written? What was the area of the United States at that time? (Page 51)
5. How many states ratified the Original Constitution? Where? When? (Page 52)
6. What can Congress do? How is it organized? (Page 53)
7. How were United States Senators first chosen? How are they now chosen? (Page 54)
8. Are you able to name ten powers given by the Constitution to Congress? Five powers denied to Congress? Two powers denied to the States? (Pages 58, 59, 60)
9. Name the qualifications of a President. How long does the President hold office? Can he be re-elected? Name some of his powers, duties. Who succeeds the President in case of death? (Pages 61, 62, 63)
10. If a great strike should occur in the coal mines of this country and the public face the winter with no coal, what could the President constitutionally do? What do you think he should do?
11. Define Treason. (Page 65)
12. If a man commits a crime in the State of Texas and flees to the State of Arkansas, can the authorities of the first State bring him back for trial? How? (Page 65)
13. Why does not the oath that all public officials must take contain a religious test? (Page 67)
14. Why are the first ten Amendments to the Constitution called "The American Bill of Rights"? Name the rights that relate to the arrest, trial, and punishment of criminals. (Pages 68, 69)
15. Can a state abridge the rights of any citizen of the United States? (Page 72)
16. Should amendments to the Constitution be made easier? Why?

CHAPTER V—AMERICAN CITIZENSHIP

1. Why is citizenship "the highest and greatest gift of the Nation?" (Page 77)
2. In what three ways may an alien become a citizen of the United States? Give the words of the new law that applies to the naturalization of women. Should an American woman who marries a foreigner lose her American citizenship? (pages 77, 78, 79)
3. Japanese and Chinese aliens cannot become citizens of the United States. Do you think this right? (Page 79)
4. Why should citizenship be denied to those who cannot read and write the English language? (Page 79)

5. Suppose a married couple from Italy come to the United States. The husband refuses to take out citizenship papers. Should the wife be allowed to become a citizen of this country even though her husband does not wish to become one? (Page 78)
6. What are the four necessary steps which must be taken by an alien to become an American citizen? Describe each step in detail. (Pages 79, 80, 81, 82, 83)
7. Give the Oath of Allegiance. (Page 83)
8. How may a soldier or sailor become a citizen? (Pages 84, 85)
9. An alien lives in the United States twenty years without becoming a citizen. War breaks out. Would the United States be justified in telling this man to join its army and, if he refuse, to leave the country? (Page 85)
10. Can citizenship ever be taken away? Give instances. (Page 86)
11. Name three rights of a naturalized citizen, and three duties. Are his rights and duties different from those of a native born citizen? (Page 87)
12. Why is a speech advocating the use of violence an abuse of the right of free speech in a democracy like the United States? What should be done to a person so abusing this right? (Page 88)
13. Can a naturalized citizen become President? Name three naturalized citizens from your state who hold, or have recently held, public office. (Page 88)
14. Why is self-control such an important quality for the citizens of a democracy to possess? (Page 89)
15. What does the Flag represent? What is the meaning of the expression "Courtesy to the Flag"? Give the words of the Pledge of Allegiance. (Page 89)

CHAPTER VI—PARTY GOVERNMENT

1. Why are political parties necessary in a democracy? "Self-government means the rule of the majority." Why should this be? (Pages 91, 92)
2. Why is it better for a country to have its political parties founded on big, broad political and economic issues which appeal to all classes of voters, rather than to have parties founded on class or religious issues? (Pages 92, 93, 94).
3. Why should the United States insist that there be only one vote—an American vote? (Page 94)
4. How do political parties resemble an army? How do they differ from an army? (Page 96)
5. Why does a political party need money? (Page 98)
6. Is it better to have a bad law adopted or a weak man elected in a fair and honest election, than it is to have a good policy adopted or a good man elected by dishonest methods? Should a democracy ever recognize corrupt or violent methods in winning an election? Does the end ever justify the means in politics? (Page 100)

CHAPTER VII—OUR VOTE IN GOVERNMENT

1. How do you take a legal part in the government? (Page 105)
2. Have all citizens the voting privilege? What are the tests you must meet before voting for the Governor of your state? (Page 107)
3. Why are property tests generally excluded in voting? (Page 108)
4. Why is the history of the world in the future to be determined by the votes of every-day men and women? (Page 111)
5. Define (1) Polling Place, (2) Election Officials, (3) "Challenged", (4) Ballot, (5) Spoiled Ballot, (6) Voting Booth, (7) The Secret Ballot, (8) Split Ticket, (9) Registration, (10) Suffrage, (11) Electorate, (12) Party Watchers. (Pages 109, 110, 111, 112, 113, 114)

6. What is the difference between a Massachusetts Ballot and a Party Column Ballot? What kind is used in your state? (Pages 114, 115)
7. Should a voter join a political party? Give reasons. (Page 115)
8. What is the difference between an open and closed Primary? Is a Primary Election conducted in a different way from an ordinary election? (Page 116)
9. Should citizens be compelled to vote? Give reasons. (Page 117)
10. What is the effect in a democracy of uneducated and unintelligent voters? (Page 118)
11. What is the supreme task of the Schools? Give reasons. (Page 119)

CHAPTER VIII—OUR REPRESENTATIVES IN GOVERNMENT

1. What are some of the difficulties which keep a government from always acting justly and wisely toward all of its citizens? (Pages 121, 122)
2. Why is real progress in a democracy made slowly, step by step? Why are laws which are passed as a result of hasty action likely to do more harm than good? (Page 122)
3. What kind of government has the United States? Democratic? Despotic? Representative? Give reasons. (Page 123)
4. If you were elected to the United States Senate from your state, would you feel it your duty, while in Congress, to place the interests of your own particular state first, or the interests of the Nation as a whole?
5. If a friend of yours whom you knew had little ability was running for office, and his opponent was unknown to you, personally, but of known ability, for whom would you vote? Why? (Page 125)
6. What is the chief responsibility of the voter? (Page 125)
7. Is it reasonable to believe that a group of representatives in Congress or in a state legislature, could pass better laws than would be passed by the voters themselves? Give reasons for your answer. (Page 126)
8. What is (1) a Direct Primary, (2) a Referendum, (3) the Initiative, (4) the Recall? (Pages 128, 129, 130, 131)

CHAPTER IX—TAXES AND GOVERNMENT

1. Name twelve officials of the government who do things for you. (Page 134)
2. Why should we be careful in our criticism of government expenditures? (Page 134)
3. Name three ways in which the government restricts you in your daily life. Name five ways in which the government protects you. Name six ways in which the government is assisting you to do better work and to be a better citizen. (Pages 134, 135, 136, 137, 138)
4. Name three things that the National Government taxes, three that your state government taxes, three that your local government taxes. (Pages 139, 140, 141, 142, 143)
5. What difficulties face a governor or a mayor who attempts to reduce the expenses of a state or city government? (Page 147)
6. What is a tax? Does every wage-earner pay a tax? Name a tax which you pay. How do you pay it? Should everyone, no matter how poor, pay a tax? What taxes do people pay without knowing it?

CHAPTER X—THE NATIONAL GOVERNMENT

1. Why do the American people to-day look to the President for national guidance and leadership rather than to Congress? Is this a good tendency? (Page 149)
2. The President has a position to fill in a certain state. The Senators of that state recommend a man whom the President thinks not quite fit for the job. He knows, however, that if he does not appoint the man, the Senators will not support him on an important piece of legislation. Should the President appoint the man? (Page 150)
3. How is the President elected? What are his constitutional powers? Why should the President be Commander-in-chief of the Army and Navy? (Pages 149, 150, 151, 152, 153, 154)
4. Why is the President's Cabinet called his official family? Is the President obliged to follow the opinions of the members of his Cabinet? May he disregard their opinions entirely? (Pages 155, 156)
5. What are the ten great departments of the United States in the order of their formation? What are their chief duties? Name the present head of each department. (Pages 156, 157, 158)
6. Name an important independent establishment of the Government. What is its work? (Page 159)
7. Why are Committees in Congress absolutely necessary? (Page 162)
8. Trace the course of a bill introduced in Congress until it finally becomes a law of the United States. What kind of bill must originate in the House of Representatives? (Page 166)
9. How are the members of the United States Supreme Court appointed? What are their terms of office? Why is the United States Supreme Court so important a part of the American Government? (Pages 167, 168)
10. Outline the judicial organization of the United States. (Page 168)

CHAPTER XI—STATE GOVERNMENT

1. Add five more ways to the ones already given on Page 171 in which your state government touches your daily life.
2. Why is the title "The United States of America" an exact description of the American form of Government? What other countries have adopted this federal form of government since the United States was organized? Could all the countries of South America be united under this plan? (Page 172)
3. In what ways do state governments correspond in their organization to the Federal Government? (Page 172)
4. Why should every citizen carefully watch the work of his representatives in the state legislature? (Pages 173, 174)
5. What may a Governor do in case of riots or uprisings in a state? What are some of the Governor's other powers? (Pages 174, 175, 176)
6. A man has worked in the party organization of his state for ten years. His party elects a Governor and a majority in the State Legislature. A \$10,000 position in the state service is open. He asks the Governor for the position. Should the Governor appoint him? (Page 177)
7. What state activities have been organized to protect (1) the business man, (2) the investor, (3) women and children, and (4) the laboring man? (Pages 178, 179, 180)

CHAPTER XII—LOCAL GOVERNMENT

1. In what way are the counties and townships of a state in a different relation to their state government than the state is to the Federal Government of the United States? (Pages 185, 186)
2. Why do the Southern States have a different form of local government from the New England States? Would it be possible to have all forms of local government the same? (Pages 186, 187, 188)

3. Would the holding of old fashioned town meetings by the citizens of New York, Chicago or Philadelphia be a practical method, to-day, of conducting the affairs of these cities? (Page 187)
4. Why is local government important?
5. If a murder should occur in the immediate vicinity in which you live, what county officials would be brought into the case? (Page 189)
6. What county officials did you vote for in your last county election? (Page 189)

CHAPTER XIII—THE AMERICAN CITY

1. Can you name ten other ways than those given on Pages 193 and 194 in which your city serves you?
2. Young men and women from the country are coming to the cities. Is this a good thing? If not, what would you do to stop the movement? (Page 195)
3. Name five reasons for the great growth of American Cities. Why is this growth likely to change American political thought? Will the change, in your opinion, be good or bad? Why is a large farm population a good thing for a nation to have? (Page 196)
4. What is a city? What can a city do? (Page 197)
5. Why should a city have as large control as possible over its own affairs? Why is it very unwise for a state to give any city absolute control over its own affairs? (Pages 198, 199)
6. What are the three general types of American city government? What type is used by your city? Do you think a change to one of the other two types would be a wise move on the part of your city? (Pages 201, 202, 203, 204)
7. Examine the last edition of your local paper and note the items relating to the work of your city government.
8. What does your city do for (1) its poor, (2) its children, (3) its sick (4) its business men, (5) its working people? (Pages 205, 206)
9. In what way could your city be made (1) more beautiful, (2) more convenient, (3) more safe? Has your city a plan for its future growth? If not, what can you do to help in getting one?

CHAPTER XIV—AMERICA—A WORLD NATION

1. Should the Hawaiian Islands be made a State of the United States? How may these Islands become a state?
2. The Filipinos are asking for Independence? Do you think the United States should grant them this privilege? Now?
3. How are the following governed? (1) Hawaii, (2) Philippines, (3) Porto Rico, (4) Alaska, (5) District of Columbia, and (6) Panama Canal Zone?
4. Write your own comment (about 250 words) on the idea expressed in the cartoon on page 215.

INDEX

- Accused, rights of, 44.
 Agriculture, Department of, 141, 157, 161
 Allegiance, Oath of, 83; pledge of, 89.
 Alaska, 212, 214.
 Aldermen, 106.
 Aliens, 77; naturalization of, 77; children of, 86; naturalized aliens who have held public office, 88.
 Ambassadors, 150.
 Amending the Constitution, 40, 66, 172.
 Amendments to Constitution, 68.
 American Documents, 20, 38, 39, 40.
 American Revolution, conditions after, 47.
 Army, U. S., 23; Congress has power to support, 59; obligations to, 140; President, Commander-in-Chief of, 63, 151; Department of War, 157.
 Arnold, Benedict, 65.
 Articles of Confederation, 48.
 Assembly, 32, 173.
 Assembly districts, 173.
 Attorney-general, 174, 177.
- Bail, 69.
 Ballots, secret, 112; Kinds of, 113; Massachusetts, 114; split, 114, illustration of, 115; Party Column, 115; Spoiled, 116, 117.
 Banks, supervision, 180, 181.
 Bill of attainder, 60.
 Bill of Rights, 21, 38, 40.
 Bills in Congress, 57; How bills become laws, 57, 162, 164, 166.
 Boss, political, 102.
 Budgets, city, 206; Federal, 147.
 Bureau of Engraving and Printing, 29.
 Bureau of Naturalization, 81, 82, 84.
- Cabinet, President's, 155.
 Candidates, selection of, 128.
 Capitol, national, 42.
 Capitols, State, 42, 174.
 Caste, system, 35.
 Caucus, political, 97.
 Census, 158.
 Certificate of Arrival, 77, 80.
 Certificate of Naturalization, 83, 84.
 Charter, town, 191; city, 198.
 Circuit Court of Appeals, 168.
 Circuit Courts, 181.
 Children's Bureau, 158.
 China, Constitution of, 21.
 Citizenship, greatest gift, 77; classes in, 84; difficulties in acquiring, 85; rights and privileges of, 87; obligations, 89. See *Naturalization*.
 Citizens, well meaning, 15; thoughtless, 16; privileges and immunities of, 65, 89; obligations of, 89; Qualities of good, 89; naturalized citizens who have held or hold public office, 88; right to vote, 105; Education of, 119.
 City, activities of the government of, 193, 194, 205, 206; growth of, 195; reasons for growth of, 196, 197; improvement in government of, 197; what is a, 197; authority of a, 198, 199; State supervision necessary, 199; government of, 200; Mayor-Council type of government, 201; Commission form, 202; city-manager form, 204; public works of a, 206; finances of a, 206; citizen's responsibility to a, 206; Planning a, 207.
 City Manager, 204.
 City Planning, 207.
 Civil Law, 45.
 Civil Service Commission, 159, 164.
 Civil War, cause of, 93.
 Coast Guard, U. S., 156.
 Colonial Policy, U. S., 213.
 Commander in chief, 63.
 Commerce, dept. of, 162.
 Commerce, power of Congress to regulate, 58; Department of, 140, 162.
 Commission form of City Government, 202.
 Commissions, U. S., 158.
 Committees, party, 98.
 Comptroller, 174, 177.
 Committees in Congress, 162.
- Conference on the Limitation of Armaments, 30.
 Confidence, need of, 13.
 Congress, powers of, 53, 56; adjournment of, 56; pay, privileges and prohibition of members of, 57; resolutions in, 58; powers granted to, 58; powers denied to, 59; message to, 63; public opinion reflected by acts of, 131; two houses of, 160; passing of bills in, 164, 166.
 Congressional Record, 56.
 Conservation, National, 157; State, 179.
 Constitutional Convention, 49, 50.
 Constitutional law, 27, 38, 41.
 Constitution of States, 173.
 Constitution of the United States, Preamble to, 20; tests for democracy, 27, 39; Amending, 40; signers of, 52; text of, 53, 54, 55, 56, 57, 58, 59, 60, 61, 62, 63, 64, 65, 66, 67, 68, 69, 70, 71, 72, 73, 74, 75; supremacy of, 67; ratification of, 67; power to raise taxes given by, 144.
 Consuls, U. S., 30, 86.
 Continental Congress, 48.
 Convention, national, 98.
 Cooperation, need of, 13.
 Copyrights, 136.
 Cornwallis, 48.
 Court House, 190.
 Courtroom, 182, 206.
 County, government of, 187, 189; importance of, 189; courts of, 189.
 Courts, 29; city, 183; county, 181; criminal, 45; District, 181; Federal, 33, 166; juvenile, 183; state, 180; surrogate, 45; territorial, 169.
 Courts, need of, 17, 33, 45.
 Court of Claims, 169.
 Court of Common Pleas, 181.
 Court of Customs Appeal, 169.
 Criminal Law, 45.
 Czecho-Slovakia, Constitution of, 21.
- Declaration of Independence, facsimile of, 6; words of, 7; signing of, 20, 39.
 Declaration of Intention, 80. See *Naturalization*.
 Declaration of Rights and Grievances, 39.
 Delegates, difference between representatives and, 125.
 Democracy, American, 21; enlightened, 23; tests of, 26, 27; definition of, 27; pure, 28; representative, 28.
 Democratic Documents, 20, 38, 39, 40.
 Departments of—Commerce, 140, 158; Agriculture, 141, 157; State, 30, 64, 151, 155, 156; Treasury, 30, 60, 156; Justice, 86, 153, 157; War and Navy, 157; Interior, 157; Post Office, 157; Labor, 158.
 District of Columbia, 212.
 District Courts, 169.
 Districts, local, 191.
 Divorce, 28, 171.
- Education, Democracy depends on, 18, 141; Citizenship, 119; vital need of, 129; public, 137, 194.
 Elections, 56; national, 101; Presidential, 154.
 Electoral College, 62, 154.
 Electorate, 105, 129. See *Vote*.
 Emblems, Party, 95, 128.
 Eminent Domain, 199.
 Employment Service, U. S., 158.
 Evening Schools, 119.
 Executive Division of government, 31, 32, 61, 169.
- Far West, local government in, 188.
 Federal Courts, 33, 64, 166; how judges are appointed to, 166; Supreme Court, 167; Circuit Court of Appeals, 168; District Courts, 169; Special Courts, 169.
- Federal Government, 27; protection guaranteed to states by, 66; activities of, 140; Executive Departments of, 140; States necessary to, 172.
 Federalists, 93.
 Federal Reserve Board, 136, 159.
 Flag, U. S., courtesy to, 86, 87; Pledge of Allegiance to, 89.
 Floor Leader, 162.
 Food and Drug Act, 18, 158.
 Forest Conservation, 179.
 Forms of Government, monarchy, 25; oligarchy, 25; democracy, 25.
 Franklin, Benjamin, 49.
 Freedom, of Speech, of Press, from search and seizure, 68.
 Fundamental Law, 27, 38, 41.
 Federal Trade Commission, 150, 158, 169.
 Federation, 29.
 "Filibuster," 164.
 Filipinos, 211.
 "First Papers," 80.
 "Free Silver," 93.
 Fugitives, 65.
- Galveston, 202.
 Gold standard, 94.
 Government, basis of, 14; organization of, 14; purpose and need of, 14; food inspection by, 18;—our agent, 18; servants of, 19; organized groups of, 27; State, 27, 171; local, 27, 185; national, 27, 149; three divisions of, 31, 33; rules of, 56; a two-party, 95; progress in, 121; representative, 123; reforms of, 127; tasks of, 135; problems of, 147; territorial, 213.
 Government Printing Office, 159, 164.
 Governor, State, 174, 175; Legislature, power of, 175; appointing power, 176.
 Graduated or Progressive Tax, 143.
 Grand Jury, 44.
 Guam, 212.
- Habeas Corpus Act, 38, 60.
 Hamilton, Alexander, 49.
 Hawaiian Islands, 209.
 Health Department, 138, 141, 194.
 Home Rule, 186, 198, 213.
 House of Representatives, 53, 160, 161; qualifications of representatives, 53; direct taxes and, 54; President elected by, 70, 155; Speaker of, 54, 161; committee system of, 162.
- Illinois, subdivisions of, 185, 186; State Legislature of, 186.
 Illiteracy, 141.
 Immigration to U. S., 77; Department of Labor's work on, 158.
 Impeachment, 64, 153.
 Income tax, Amendment, 73; money received from, 142.
 Independence Hall, 39, 48.
 Independent Boards and Commissions, 158.
 Indians, care of, 157.
 Inheritance tax, 143.
 Initiative and Referendum, advantages, disadvantages of, 130.
 Interior, Department of, 157.
 Internal Revenue taxes, 142.
 Interstate Commerce Commission, 150, 158, 169.
 Irrigation, 157.
- Judges, appointment of, 150; Federal, 106
 Judicial divisions of government, 31. See *Judiciary, Courts*.
 Judicial System of U. S., 168.
 Judiciary, 33.
 Judicial Powers of U. S., 70.
 Jury, Trial by, 64, 69.
 Justice, fugitives from, 65; Department of, 157.
- Labor Dept. of, 158, 163.
 Laws, need of, 17, 35; beginning of, 35; custom and, 36; definition

- of law, 37; public opinion and, 37; source of, 43; kinds of law, 43; difficulty of making, 44; power of Congress to make, 53, 59. See *Constitutional Laws, Fundamental Laws, Statutory Laws, National Laws, State Laws, Civil Law, Criminal Law.*
- Legislative division of government, 31, 33, 53, 169.
- Legislation, 121; initiative, 128.
- Legislatures, State, 31, 32, 40, 173, 186; Power of, 173.
- Library of Congress, 48, 137, 159.
- Licenses, 143, 178.
- Lincoln, Abraham, 12, 71, 93, 102; Gettysburg, address of, 152.
- Local Government, work of, 27, 28; taxes raised by, 143; forms of, 185; sub-divisions of, 185, activities of, 185, 189; State supervision of, 186; varieties of, 186; origin of, 186; New England form of, 187; officials in, 187; South and West forms of, 188; Louisiana forms of, 188; Far West form of, 191.
- Louisiana, forms of local government in, 188; parish in, 188.
- Loans, Liberty, 139; Victory, 140.
- Madison, James, 49.
- Magistrate, 33.
- Magna Carta, 21, 38.
- Majority, 31.
- Manager, City, 204.
- Mayflower Compact, 20.
- Mayor, 32, 33, 105.
- Mayor-Council type of City Government, 201.
- Message to Congress, 63.
- Militia, power of Congress to call forth, 59; right to bear arms, 68; State, 176, 179.
- Mints, U. S., 29.
- Money, 13, 29; Continental, 47; power of Congress to borrow, 58; to coin, 58; counterfeiting of, 58; how drawn from Treasury, 60, 157.
- Monroe Doctrine, 209.
- Municipal Government. See *Local Government.*
- Museums, 137.
- National defense, 135.
- National Committees, 98.
- National Government. See *Federal Government.*
- Naturalization, power of Congress to establish uniform rules of, 58; how to acquire, 77, 78, 79; four steps in, 79; Bureau of, 81, 82, 84, 158; certificate of, 83; fraud and penalties in, 84; Soldiers and Sailors, 84.
- Navy, U. S., 23; Congress has power to maintain, 59; obligations to, 140; President, commander-in-chief of, 63, 151; Department of, the, 157.
- New England Town Meetings, 123, 187
- New York, 138.
- Nobility, no title of, 60.
- Oath, President's, 63; official, 67; allegiance, 83; Boys of old Athens, 207.
- Ordinances, 28, 42.
- Original Thirteen States, 47; ratification of Constitution by, 52; representative government began in, 123.
- Organization, Club, 39; Government, 40.
- Panama Canal, 157.
- Panama Canal Zone, 212.
- Parks, public, 178.
- Parties. See *Political Parties.*
- Party, state ticket, 128; membership, 115, platform, 99.
- Passport, 155.
- Patents, 136.
- Penitentiaries, 136, 157, 177.
- Pensions, 157.
- Petition for Naturalization, 77.
- Philippine Islands, vaccination in, 17; Government of, 210.
- Police, duties of, 15; need of, 17.
- Political Parties, 91; democracy and, 91; organization of, 92, 96; issues of, 93; citizens of all creeds and races in, 94; built like an army, 96; machinery of, 97; Candidates of, 97; Conventions of, 97; Committees of, 98, 99; corrupt methods of, 100; Educational work of, 103; how to become a member of a political party, 115.
- Polling place, 109.
- Porto Rico, 211.
- Post Office, 30; power of Congress to establish, 58; work of, 136.
- President of U. S., term of office, 61; How chosen, 61, 70; Qualifications of, 62; in case of death of, 62; Compensation of, 62; oath of office of, 63; Powers of, 63, 149; duties of, 63; impeachment of, 64; how nominated, elected, 99; head of whole nation, 101; who votes for, 105; increase of executive power of, 149; strength of, 149; appointments of, 150; commander-in-chief of army and navy is, 151; legislative power of, 152; power of pardon of, 153; party leadership of, 153; Election of, 154; Cabinet of, 155, 156; veto power of, 166.
- Presidents of United States, 151, 153.
- Primaries, 97; Direct, 128; Open and Closed, 116; advantages of, 129.
- Prohibition, amendment, 74; taxes cut off because of, 142.
- Property, 28; qualifications for voting, 108.
- Public Debt, 73; Victory and Liberty Loans, 140, 156.
- Public Health-Service, doctors of, 18; State, 178; Department of, 206.
- Public Lands, 157.
- Public Libraries, 137, 194.
- Public Safety Departments of a City, 205.
- Public Schools, 18, 141, 119, 129, 137, 194, 206, 215.
- Public Servants, 19, 177.
- Public Works, 206.
- Qualifications of voters—property, age, sex, 108, 109.
- Races, characteristics of, 22.
- Recall, advantages and disadvantages of, 131.
- Referendum, 106, 128, 130.
- Reform Government, 127.
- Registration, 111.
- Representatives, test of democracy, 26; necessity for, 124; value of, 126.
- Republics, 25.
- Resources, 30, 133.
- Revenue Bills, 57.
- Rights of Citizens, 69, 72, 73, 87; Constitutional, 88.
- Rogues Gallery, 177.
- Rules, need of, 15.
- Samoa, 212.
- Schools, Public, 119, 194, 205.
- "Second Papers," 81.
- Secretary of State, 151, 174, 177.
- Senate, U. S., 54, 160; power to try impeachment, 55; President of, 55, 163.
- Senators, how and by whom chosen, 54; how classified, 54; Qualifications of, 55; how elected, 74.
- Senatorial districts, 173.
- Slavery abolished, 71.
- Smithsonian Institution, 160.
- Soldiers and Sailors, Naturalization of, 84.
- Speaker of House, 54, 161.
- State, amendments to constitution of, 130.
- State Constitutions, 173.
- State, Department of, 30, 64, 151.
- State, Government, work of, 28, 171, 172; powers denied to, 60;
- rights of, 70; taxes raised by, 143; Federal Government corresponds to, 172; Constitution of, 173; Legislature of, 173; Senate, 173; House of Representatives, 173; Senatorial districts of, 173; Assembly districts of, 173; Capitols of, 174; Governor of, 174; other officials of, 174; militia of, 176; Lieutenant Governor of, 176; boards and commissions of, 177; Public servants of, 177; activities of, 178; Education, 178; Public works, 179; agriculture, 179; Conservation, 179; Labor protected by, 179; Business safeguarded by, 180; Courts, 180.
- States, admission of, 66; Division of, 172; Constitution amended by vote of, 172.
- State rights, 70.
- Statutory Law, 41.
- Suffrage, Women's, Amendment, 75, 109; widening of, 110.
- Supreme Court, U. S., 33, Chief Justice of, 55, 167; Jurisdiction of, 167.
- Tariff, 93; raising money by a, 124, 142, 169; commission, 150, 159.
- Taxation, dangers in, 144; limits to, 144; problems in, 147; extravagance in, 147.
- Taxes, power of Congress to, 58; how apportioned, 60; who should pay, 133; what we get in return for our, 133; criticism of, 134; war and, 139; what the Government, 142; Internal revenue, 142; tariff, 142; State, 143; what are good, 144; indirect, 145; Justice of raising, 145; State, 180.
- Territories, U. S., 209; Government of, 209; U. S. policy to, 213.
- Township, Government, 190; officials of, 190.
- Treason, 65.
- Treasury Department, 13, 60, 156.
- Treaties, 30, 64, 151, 156.
- Trial by Jury, 40, 64, 69.
- Umpires, need of, 15.
- United States of America, two essentials of, 23; how organized, 25; growth, 51; territory and property of, 66.
- United States Shipping Board, 159.
- Vice President, 55; term of office, 61, 62; how elected, 70, 99, 154.
- Village, Government, 191; activities of, 191.
- Virginia, government first established in, 123.
- Virgin Islands, 212.
- Vote, 105; influence of, 105; officials elected by, 105, 106; privilege to, 107; safeguarding of, 107; qualifications to, 108, 109; registration of, 111; intelligent, 117; compulsory, 117; education necessary to, 118; greatest gift, the, 119.
- Voting, test of a democracy, 26; regulations, 111, 113; secret, 112; machines, 112, 113.
- War and Navy Department, 157.
- War, Power of Congress to declare, 59; Saving Stamps, 139.
- Warrants to arrest, 44, 69.
- Washington, George, 49, 50, 102, 150; monument, 150.
- Water Power, development of, 179.
- Wealth, national, 23.
- We, the People, 20, 21.
- Welfare, 206.
- Women, Citizenship of, 78.
- Women's Bureau, 158.
- Women's Suffrage. See *Suffrage.*
- Workmen's Compensation Commissions, 179; law, 180.
- World War, America's contribution, 23; taxes due to, 139; Cost of, 142.

"WE AND OUR WORK"

By JOSEPH FRENCH JOHNSON

President Alexander Hamilton Institute; Dean and Professor
of Political Economy, New York University

"*We and Our Work*" has been written to meet the demand for a new work on Economics that is in harmony with advanced educational theory and practice. The present day emphasis on the Social Studies in the Secondary Schools, together with the rapid development of the Commercial, Vocational and Junior High Schools, have brought about an insistent demand from teachers for a book on the subject of Economics that is not merely an adaptation of an existing text for advanced readers. "*We and Our Work*" meets this demand and is a new approach to the study of Economics. It will incorporate, as will all the books of the Series, the same editorial and pictorial features of "*We and Our Government*."

CONTENTS

Chapter

1. The Purpose of Work
2. The Industrial Revolution
3. American Industry
4. American Agriculture
5. Transportation
6. Classes of Workers—Manual, Mental
7. How Wealth is Produced—Land, Labor, Capital, Enterprise
8. Money, Prices and Banks
9. Large Scale Production (Trusts, Monopolies, Public Utilities, etc.)

Chapter

10. Rent and Interest
11. Profits and Wages
12. Labor Organization
13. Good Times and Hard Times
14. On Spending (Consumption)
15. Conservation: National Thrift, versus National Waste
16. To Brighten the Outlook (Reform Movements)
17. Cooperation and Prosperity

"WE AND OUR HISTORY"

By ALBERT BUSHNELL HART

Professor of Government in Harvard University

The title describes the purpose of the book. It is a clear account both of the development of the people who inhabit the country called the United States, and of their society and government. It tells how they passed from the colonial to the national condition, and from a small nation became a great nation. It follows the American people in their party and political history, their government, their occupations, their labor system, their education, their business combinations and their foreign relations. The details of elections and of military campaigns are very briefly stated. The viewpoint of the work is that the history of America is the history *not of occurrences but of human beings*. Each chapter ends with a brief account of the great man who best illustrates that epoch.

OUTLINE

PART ONE. FOUNDATIONS OF THE REPUBLIC

Chapter

1. The Land We Live In
2. First American People (1492-1775)
3. Conquest of the Wilderness (1492-1750)
4. From Colonists to Nation (1750-1789)

PART TWO. THE YOUNG UNITED STATES

Chapter

5. Getting Under Way (1789-1815)
6. Popular Government (1815-1829)
7. National Growth (1829-1861)
8. Public Questions (1829-1861)
9. The Civil War (1861-1865)

PART THREE. WELDING THE NATION

Chapter

10. Reunion of the Nation (1865-1877)
11. Politics and Public Men (1877-1897)
12. Immigrants and Emigrants (1877-1897)
13. Developing the Nation (1877-1897)

PART FOUR. REACHING OUT

Chapter

14. Parties and Presidents (1898-1923)
15. Eastward and Westward (1898-1914)
16. Care for the People (1898-1923)
17. In the World War (1914-1919)
18. What America Has Done for the World

For additional titles of books of the series, see page four.

The American Viewpoint Society
a department of Boni & Liveright, Inc., Publishers
New York City



THIS BOOK IS DUE ON THE LAST DATE
STAMPED BELOW

AN INITIAL FINE OF 25 CENTS
WILL BE ASSESSED FOR FAILURE TO RETURN
THIS BOOK ON THE DATE DUE. THE PENALTY
WILL INCREASE TO 50 CENTS ON THE FOURTH
DAY AND TO \$1.00 ON THE SEVENTH DAY
OVERDUE.

FEB 6 1934

NOV 6 1938

NOV 9 1941

NOV 20 1941

24 Mar '62 JG

REC'D LD

MAR 27 1962

SEP 11 1982 1

RET'D

AUG 5 1982

LD 21-50m-1,'3

140
m

33378

530895

JK274

JA

UNIVERSITY OF CALIFORNIA LIBRARY

