

Historic, archived document

Do not assume content reflects current scientific knowledge, policies, or practices.

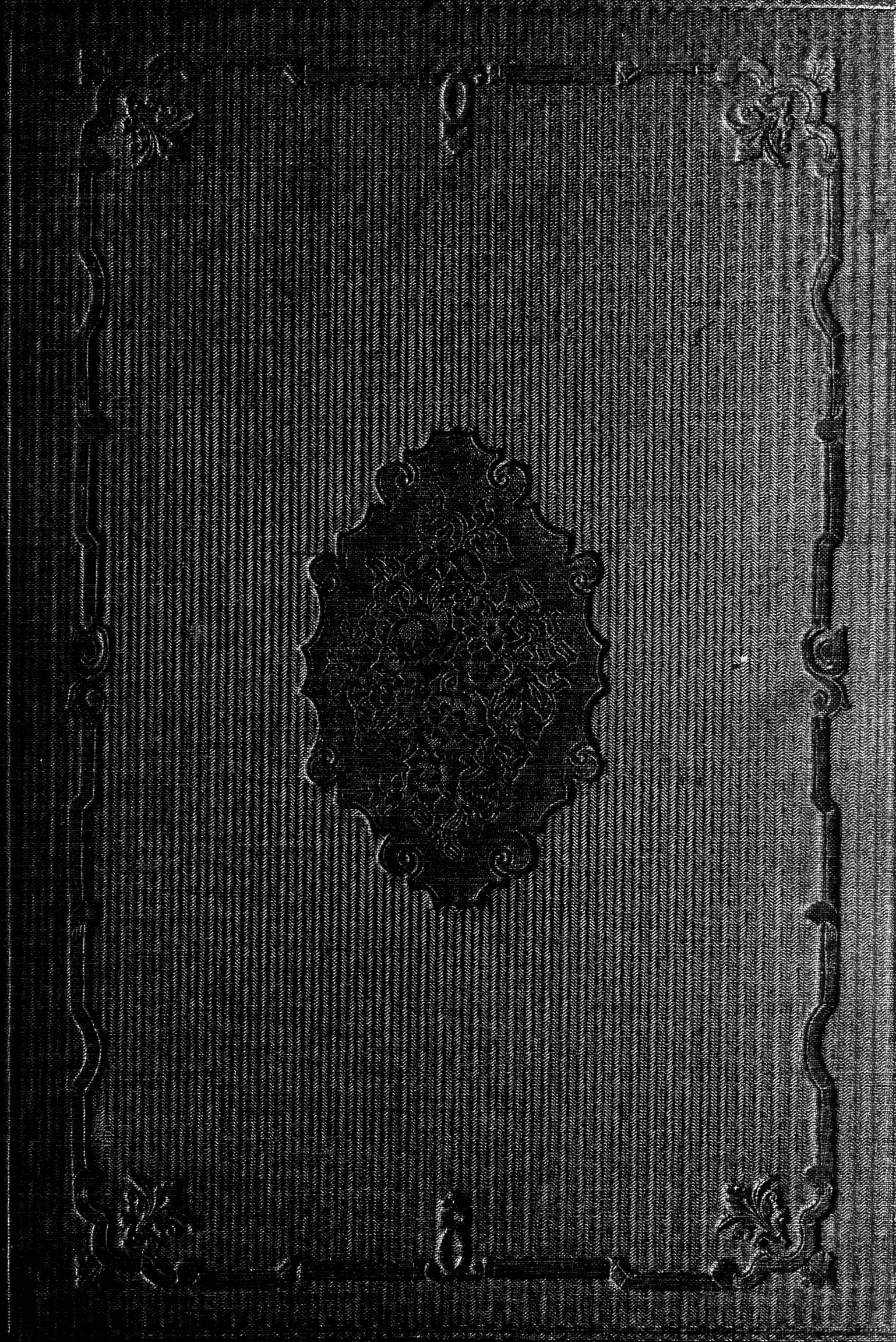

LIBRARY

OF THE

U. S. Department of Agriculture.

Class 80

8-159

J82

Ser. 1. v. 9

THE COTTAGE GARDENER,

AND

COUNTRY GENTLEMAN'S COMPANION.

CONDUCTED BY GEORGE W. JOHNSON, ESQ.

EDITOR OF THE "GARDENER'S ALMANACK," ETC.

THE FRUIT AND FORCING-GARDEN, by Mr. R. Errington, Gardener to Sir P. Egerton, Bart., Oulton Park; and Robert Hogg, Esq., Secretary of the Pomological Society.

THE KITCHEN-GARDEN, by Mr. J. Robson, Gardener to the late Earl Cornwallis; and Mr. T. Weaver, Gardener to the Warden of Winchester College.

THE FLOWER-GARDEN, by Mr. D. Beaton, late Gardener to Sir W. Middleton, Bart., Shrubland Park.

STOVE AND FLORISTS' FLOWERS, by Mr. T. Appleby, Victoria Nursery, Uxbridge.

THE GREENHOUSE AND WINDOW-GARDEN, by Mr. R. Fish, Gardener to Colonel Sowerby, Putteridge Bury, near Luton.

WOOD-CRAFT, by Mr. T. Appleby, Victoria Nursery, Uxbridge.

MANAGEMENT OF BEES, by J. H. Payne, Esq.

POULTRY-KEEPING, by the Rev. W. W. Wingfield, Secretary to the Cornwall Society for Poultry Improvement.

DISEASES OF POULTRY, by W. B. Tegetmeier, Esq.

ALLOTMENT GARDENING, by Mr. Keane and others.

VOLUME IX.

LONDON :

PUBLISHED BY WM. S. ORR AND CO., AMEN CORNER.

1855.

THE COTTAGE

COUNTRY, GREAT BRITAIN

CONDON

THE EDITOR AND PUBLISHERS
OF THE COTTAGE
AND THE COUNTRY
AND THE GREAT BRITAIN
AND THE CONDON

DEPARTMENT
OF THE GREAT BRITAIN
AND THE CONDON

PUBLISHED

I N D E X.

- ABELIA uniflora and its culture, 453
 Acacia culture, 441; dealbata, or affinis hardy, 421; celsastrifolia, 500
 Achimenes in autumn, 114; list of, for greenhouse, 151; culture, 440
 Advertisements, 33
 Ægilops ovata, 215
 Aerides, culture, 233
 Æschynanthus splendidus, 122
 Agapanthus umbellatus, 20; list of, 141
 Age, exemptions, 413
 Agricultural Society of England's Meeting, 465
 Agricultural training for boys, 467; operations for March, 505
 Air, promoting its circulation, 333; admitting, 440
 Albuca, list of, 141
 Ale, the pint o', 464
 Allamanda, treatment of weak, 53; in pots, to manage, 194; Schottii, 194
 Allotment Farming—November, 64; December, 148; January, 247; February, 327; March, 407; April, 506
 Allotments, rules for their establishment, 204
 Alpina nutans not flowering, 472
 Alstromerias, list of, 142, 160; dying down, 194
 Amaryllis, culture at Claremont, 60; list of, 161; reticulata, 221; to discern from a lily, 303; culture, 332; Atamasco and formosissima culture, 393
 American garden, to construct, 271
 Animals, notes about, 469
 Anomatheca cruenta and juncea, 240
 Antholyza, list of species, 203
 Annuals, rules for sowing, 134; sowing in turf, 491
 Apis muscorum, 89
 Apples, list of, for espaliers, 33; Beauty of Kent, 36; list of dessert, 157; descriptive list of kitchen, 176; gathering, 294; list of, 314; annual imports, 357, 397; in Derbyshire, 394
 Approaches, to form, 296
 Apricot as a standard, 72; pruning, time for, 194; diseased, 234; cause of decay, 317
 Aralia japonica, 82
 Araucaria Bidwilliana, 499
 Arbor vitæ sowing, 354
 Arches over walks, 20
 Asparagus, beds, making, 325; forced, 421
 Attachment, singular, 313
 Auricula, soil for, 363; spring treatment of, 284; autumn and winter culture, 306; its winter treatment, 323; its properties, 342; diseases, 343; list of, 343
 Australia, plants for, 20
 Azalea japonica, 142; sowing, 353; indica culture, 441
 Azara integrifolia culture, 284
 BABIANAS, their culture, 203
 Bacon Hopper, 252, 354
 Balsam cuttings, 52; sowing, 374; culture, 442; sowing for July, 431
 Bank, sloping, for fruit, 94; plants for a green, 233; plants for river, 234
 Barnardia scilloides, its culture, 203
 Barrenwort, 55
 Bath and West of England Agricultural Show, 413
 Beans, culture of, 385
 Beatonia, species of, 203
 Beautiful, influence of, the 221
 Bedding-out plants, 26; distances for, 134
 Bedding plants and bulbs, 20; white, 374
 Bees: honey harvest, 15; new mode of managing, 15, 53; particulars of twelve stocks, 16; drones seen late, 33; honey season in Northumberland, 48; confining, 49; wild, Apis lapidaria, 51; Calendars—November, 66; December, 150; January, 248; February, 328; April, 507; ventilation, 66; north aspect for, 66; dividing hive for obtaining artificial swarms, 66; Taylor's notes on, 66; Golding's improved hive, 73; age of young broods, 73; wild, 89, 112; harvest of 1852, 93; honey-harvest on moors, 110; swarming with young queen, 153; management, 173; in Taylor's hive, 174; using old comb, 174; notes on, 192, 252; honey harvest in Lincolnshire, 213; destroying royal cells, 214; feeding and hives, 248; necessity for feeding, 269; in boxes, 353; feeding, early breeding, cleaning floorboards, snow, recipe for barley-sugar, 409; excess of drones, 491; entrance to Taylor's hive, 492; artificial swarms, 430
 Bee-boxes, 449; with the comb broken down, 452
 Begonia parviflora hybrid, 17; Evansiana, wintering, 105; hybrid, 123; winter blooming and culture, 304; Thuaitesii and culture, 415; sowing, 471
 Bell-glasses, 496
 Belts of trees, 474
 Berberis vulgaris, 21
 Bessera, list of species, 204
 Bignonia radicans, treatment, 53; radicans major not thriving, 193
 Birds, familiarity of, 19
 Blandfordias, list of and culture, 204
 Boleti, list of eatable, 169
 Bomareas, list of and culture, 240
 Borders, arrangement of, and list of plants, 345
 Botanical terms explained, 452
 Bouquet in Covent-Garden, 78, 99; model, 158; d'amour, 313; price of, 341
 Brava geminiflora, 241
 Brodiaeas, list of and culture, 241
 Brunsvigias, 242; list of and culture, 260
 Buds and bulbs, on the possibility of combining, 375
 Bulbine, 301
 Bulbs, hardy and half-hardy, their culture, 140, 160, 203, 240, 260, 301, 319, 361, 399, 438, 477; for large beds, 173; leaves, 451
 Bullfinch diseased, 114
 CABBAGE, culture of Thousand-headed, 33; tribe, notes on, 46; protecting, 243; culture, 328, 386; weevil, 359
 Cabbage-worts, their value, 65
 Cactus culture, 472
 Calceolaria seed, sowing, 52; list of yellow, 152; for bedding in shades, 412, 471; culture, 459; compost, 431
 Calendar for November, 73; December, 153; January, 253; February, 333; March, 413; April, 510
 Californian agriculture and horticulture, 373
 Calliphurria Hartwegiana, 302
 Callithauma, species and culture, 302
 Calochortus, species and culture, 302
 Calostemmas, list of and culture, 319
 Calthorpe's (Lord) small garden tenants, 158
 Camellia buds falling, 94; turned brown, 252
 Campanula Carpaticas flowering, 113
 Camposema rubicunda, 1
 Canna, wintering, 105
 Cantua dependens culture, 8; injured by heat, 33
 Cape Jasmine not flowering, 152
 Cape of Good Hope wines, 318
 Carnation soil, 73; layering, 194; culture of perpetual, 205
 Carpodotes, its culture, 320
 Carpolyza spiralis, 320
 Carrot failure, 234; culture on unsuitable soil, 463; sowing, 506
 Cassia corymbosa as a standard, 145
 Castuses when resting, 194
 Cattleya guttata, 220; mossiæ, culture, 233; pallida, 500
 Cauliflowers, wintering, 46, 63
 Ceanothus rigidus culture, 9, 275; azureus, 33, 92; in Devonshire, 275; list of and culture, 281, 422
 Celery blight, 94; best kinds, 134; coal-ashes as a preservative of, 185; cause of decay, 234; and its cultivation, 484
 Celsia Cretica, 94
 Cereus (night-blowing) in greenhouse, 52
 Chaffinch's familiarity, 19
 Cheese dairying, 138
 Chelidoniums, 473
 Cherries in Derbyshire, 394
 Chilworth's (Rev. J. L.) residence, 103
 Chiswick Shows in 1853, 138
 Chlidanthus fragrans culture, 320
 Choretis, list of and culture, 320
 Chrysanthemum forcing, 20; Pomponé Hendersonii, 82; time of flowering, 122; culture, 223; list of, 243
 Cider-making in Herefordshire, 291; sweet, making, 488
 Cinchona Calisaya, and culture, 493
 Cinchonads, how known from Madderworts, 75
 Cinerarias mildewed, 20; sowing, 73, 460; blooming in November, 152; blooming in March, 294; amelloides, propagating, 412; compost, 431
 Claremont, visit to, 59
 Clanthus puniceus, wintering, 204, 314; in room, 234
 Climate, vicissitudes in our, 486
 Climbers, a purple autumn, 33; for greenhouse, 72; list of tender, 173; in stove, 332; hardy, 393; for high wall, 413; combination of, 423
 Clivia nobilis culture, 320
 Coburgias, list of and culture, 320
 Cochlearia acaulis, 83, 342
 Cockle beds, 72
 Cockscomb culture, 442
 Collanias, and their culture, 361
 Colocordium culture, 302
 Commelina scabra, and culture, 35; wintering, 105
 Conantheras, and their culture, 361
 Coniferae, 86, 125, 164, 206, 244, 285, 324, 365, 403, 443, 482; at Finedon Park, 106; sowing Himalayah, 253; planting, 431
 Conifers, time for planting, 33
 Conservative walls, their use, 224
 Conservatory, heating a small, 134
 Cooperias, and their culture, 361
 Coreopsis filifolia, 83
 Cornelian cherry, as a fruit, 59
 Coronillas, list of, 422
 Correas, list of, 422
 Cosmos bipinnata, 83
 Cottage garden and its November crop, 48
 Cottagers, prizes for, at Shows, 106; a chapter for, 385
 Couch grass, its impoverishing power, 467
 Country Gentleman's Companion, 152
 Courteen Hall Gardens, 144
 Couve tronchuda, 492
 Covent-Garden notes, 2, 23, 36, 56, 77, 99, 117, 136, 157, 176, 198, 216, 236, 257, 298, 316, 337, 359, 378, 398, 417, 435, 456, 475, 495; fraudulent measures at, 278; cut flowers at, 341
 Cows, oat straw for, 214; turnips required for, 214; murrain in, 432
 Crab stocks, grafting, 114
 Crinum, and their culture, 361
 Crystal palaces, Rivers's, 18
 Cucumber house, 73; pit and its management, 187; forcing, 234; early, in dung-bed, 239; removing male blossoms, 253; culture, 412; useful sorts, 432
 Cumingia, species and culture, 399
 Cunninghamia sinensis, 9
 Cupressus, various species, 9; list of species, 45; Govenii in bloom, 458
 Cuttings, how to strike, 152; bottom-heat for, 354
 Cyanella, species and culture, 400
 Cyclamen, leaves decaying, 173; lost their leaves, 393
 Cyclobothra, species and culture, 400
 Cypella, species and culture, 401
 Cypripedium soil, 492
 Cyrtanthus, species and hybrids, 401; list of species, 438
 Cytisus filipes, 422
 DACRYDIUMS, list of, 86
 Dahlias, seedlings for 1853, 29; house-sewage for, 114; of 1851, 186, 290
 Dammaras, list of, 87

- Damp, what is, 194; walls, to cure, 234
 Damsons, 93; wine, fining, 333
 Danish Isles, sixteen months in, 119; abundance of fruit there, 119
 Dantzic, a visit to, 428
 Daphnes, a few of the best, 167; *indica rubra*, 221; list of, 422
Datura just blooming, 19; requires shelter, 113; sanguinea in the open border, 221; in room, 234
 Daubenyas, 439
 Decay, its increase in plants, 338
 Decorative planting, 473
 Decoy pond and its water-fowl, 190
 De la Pre, 106
Dendrobium nobile Blandianum, 500
 Dessert, fruits for winter, 259
Deutzia gracilis and *scabra* culture, 8
 Dewing, its meaning and mode of applying, 402
 Dianellas, 439
 Dibble for wheat, 233
Dichorisandra, 82
Diplacus puniceus, 422
 Double-glazing and a well as protectors from frost, 455
 Draining, 65, 497, 505
 Drain, to construct, 134
 Drimias, 439
 Dryandras, list of, 423
 Dung-beds, construction of for forcing, 286
- EARLY life of Poor Man's well-wisher, 272, 450
Echeandia ternifolia, 439
Echeveria rosea, 421
 Edgings, 108; Hogg's, 258
Edwardsia grandiflora seedling, 214, 333, 423
 Eisenbeck (Professor Von), 118, 158
 Elder juice frauds, 36
Elisene longipetala culture, 439
 Elm, the *fastigiata*, 452
Epimedium Alpinum, 55
Eranthemum, 305
Erica bicolor, with pale flowers, 73; *Banksia* dropping its buds, 152
Eriobotrya japonica, 423
Erythrina crista-galli propagating, 20, 423
Escallonia macrantha culture, 9, 423
 Espalier rail, 234
Eucalyptus, 423
Euchilus obovatus culture, 263
Eucomis culture, 440
Eucrosia bicolor, 440
Euphorbia jacquiniiflora, for wreaths, 59, 305
Eutaxia myrtifolia culture, 262
 Everlasting flowers mingled with grasses, 223
 Exhibitors of flowers, their tricks, 418
- FAIRY-RINGS explained, 469
 Fault (A) among us, 287
 Feathers, different markings described, 387; their varieties, Pencilled, 406; the Laced, 465
 Ferns, moving hardy, 54; fogging off, 94; Moore's labels for, 99; shoots, cooking, 314, 354
 Ferrarias, 440
 Finedon Park, 106
 Fish diseased, 472
 Fitzroya wood, 493
 Flax thrashing, 492
 Flower-beds, plans to be given, 20; a new one, 60; new mode of trying colours in, 471
 Flower-buds, to distinguish double and single, 33
 Flower-garden plans, (No. 1) 67, 73, 113, (No. 2) 147, (No. 3) 289, 393, 427
 Flower-markets, London, 212
 Flowers, general competition with, 218; coloured everlasting, 471
 Forcing, preparations for early, 101; notes on, 238; operations of the season, 286; its general principles, 300
 Forest Trees of Great Britain, 355
 Forests (Royal), their mismanagement, 379
 Forsaken Heritage (The), 13
Forsythia viridissima pruning, 394, 423
Forsyth MSS., 3, 36, 77, 98, 146, 357, 377, 417
 Fourcroyas, 440
 Frenelas, list of, 87
 Fruit, stores, managing, 38; and vegetable culture combined, 80; influence of soil on, 313; growing, its commercial importance, 395; how to secure a crop, 419
 Fruits, Belgian Commission on, 300
 Fruit-trees, general planting of, 137; on walls, their distances, 152; for north walls, 152; renovation of, 178, 218; for Cumberland, 294; after the mild winter, 318; grass-walk over roots, 333
 Fuchsias, list of good, 32; *spectabilis*, 33, 114; with a single stem, 52; wintering, 53, 105; list of and culture, 92; list of best, 132; straggling, 152; *Fuchsia* bed, to make, 174; culture, 249, 460; budding, 294; cordata, 342; *serratifolia* culture, 412
 Fumigating greenhouse, 54; injury from, 471
 Fungi, British eatable, 14; eatable, 109, 169; British, 189, 348; useful kinds, 312
Funkia subcordata, 17; *grandiflora alba*, 27
- GALAXIAS, 440
 Gardeners and their masters, 22; who are impostors, 257
 Gardenias for walls, 461
 Garden-orchard, 80
 Garden, restoring an old, 424, 431
 Gardens, benefits of exhibiting them, 222
 Gardiner (W.), proposed biography of, 118
 Gas, heating by, 433
 Gastromomas and their culture, 477
Gaura Lindheimeri, 26
Geissomeria aurantiaca, 420
 Geissorhizas and their culture, 478
 Gelasine and Gethyllis, 478
 Geraniums, moving into greenhouse, 20; propagating Golden-chain, 20; wintering scarlet, 33; wintering, 53, 104, 471; (Scarlet), Amazon and others, 102; cuttings of Unique, 113; as standards, 144; turning yellow, 151; unpruned, 234; (Commander-in-Chief) as a bedder, 273; management of scarlet, 354; gangrened, 354; treatment of seedling, 304; for forcing (Queen of February), 457
Gesnera Zebrina, culture, 52, 103, 205; elongata culture, 304; *Suttonii alba*, mealy bug on, 314
 Gladioli, notes on species, 174
Gladiolus gandavensis, planting out, 194; culture, 479
 Glasgow, garden near, 53; Floral Exhibition, 418
Glaucium luteum, 375; *corniculatum*, 395
 Glazing, double, 20; laps in, 20; its benefits, 55; to remedy drip, 94
 Gloxinias not bulbing, 33; management, 173; list of and culture, 252; from leaves, 376
 Gold fish in vases, 450
 Goosander, red breasted, its habits, 37
 Grafting on upper side of branches, 252; in a hotbed, 482
 Grapes, preserving, 20; Black *Barbarossa*, 84, 499; growing late, 124; caterpillars on berries, 134; diseased, 174; the Fox, as a stock, 180; forcing, good specimens of, 233; cause of their shanking, 381, 428; the *Trebiana*, 477; *Esperione* and others, 500
 Grasses as ornaments, 223
 Greasing the wheel, 166
 Greenhouse construction, 20; stages, 59; plants for back wall, 72; trellis plants, 84, 94; and vinery, 114, 363, 382; with west aspect, 114; facing the north, 214; plants, winter-blooming, 282; vines and flowers in, 294; arranging a new, 294; heating, 333, 387; climbers, 374; modes of heating small, 422, 430; in March, jottings for, 459; work there, in March, 440
Grindelia grandiflora, 115
 Guano, its composition and value, 176
 Guernsey Lily cone flowering, 273
Guzmania tricolor, 83
- HABRANTHUS and their culture, 479
Habrothamnus elegans and *fasciculatus* culture, 282
 Haemony, what is it? 114
 Hardenbergias, list of and culture, 84; mono-phylla treatment, 234
 Haricot bean, a large white, 174
 Heath cuttings, management of, 354; propagating and growing, 412
 Heat, how to retain, 415
 Heating, easy mode of, 387; economical mode of, 410; by gas, 413; a small greenhouse, 433; modes of, 501
Hedychium Gardnerianum, 471
 Hellebores, winter-flowering, 421
 Herbaceous plants, list of, 27
 Hickory nuts, sowing, 33
Hippeastrum alicium platypetalum culture, 342
Hippophae rhamnoides, 174
 Hives (Taylor's), 294
Hoarea melanantha, 17
 Hollyhocks, list of, 33, 53
 Honey harvest of 1852, 372
 Horticultural and Pomological Association, 399, 452, 470
 Horticultural Society's Meetings, 81, 122, 220, 341, 420, 457, 498
 Horticultural Society, rules for a Provincial, 265; *Peebleshire*, 266; of London first suggested, 358; its first formation, 377; in Tipperary, 477
 Hotbed, a shallow, 17; its duration if shallow, 152; for early forcing, 366; its construction and management, 480
 Hothouse, law of removing, 314
- Hot water in bottles to exclude frost, 430
 Hot-water *versus* Polmaise, 245
 Hyacinths in pots, 294; with many offsets, 471; deformed, 510
 Hybrid between sheep and deer, 470; between pheasant and fowl, 470, 472
Hydrangea culture, 413
- ICE, preserving, 214
 "I have no one to take care of me," 407
 Indian seeds, 173; corn, 499
Indigofera decora pruning, 353
 Insects, Stephens' Collection, 496
 Ipomeas, to keep free from red spider, 194
 Iris (China) culture, 54
 Irrigating with sewage, 153
 Ivy keeping walls dry, 252; pruning and propagating, 354; against a wooden fence, 491
Ixias, propagating, 53; culture at Claremont, 61
- JACKDAW's familiarity, 19
 Japan Lilies for garden decoration, 508
Jasminum, dwarfs, 61; *sambac*, management of, 194
 Jones, William and Ann, 88
 Junipers, list of, 126
Juniperus, list of species, 164, 206
Justicia speciosa culture, 304
- KEARSLEY House, 63
Kennedy, list of and culture, 84
 Kidney beans, new varieties tried, 100; forcing, 239
 Kitchen-garden crops, 328; routine, 367, 385, 408; crops, arranging economically, 504
- LABELS for Roses, 234; cheap, 386
 Laburnum, origin of the purple, 196
Lachenalia tricolor, 83
 Lady gardeners, 490
 Landscape Gardening, 296, 473; Major's, 495
Lantana mutabilis culture, 314
 Larch, its value and species, 206
 Laurels, pruning, 152; time for cutting down, 234
 Leaves, consequences of removing, 135; removing from bulbs, 335; reciprocate with the roots, 336; propagating by, 452
 Lemon trees unhealthy, 472
 Lettuces for London markets, 78
Librocedrus, list of species, 244
 Light, its importance to plants, 407
 Lilies, mixture of, 214
Lilium lancifolium, culture in greenhouse, 461; in open ground, 598
Limatodes rosea, culture, 220
Limnocharis Humboldtii, hardy, 399, 457
 Lions, tame, 470
 Liquid manure, Roe's mode of applying, 79
 Liqueur culture, 494
Lithospermum rosmarinifolium culture, 284
 Lobelias, tall, propagating, 44, 62; culture, 62; wintering tall, 105; syphilitica and cardinalis, their culture, 151; list of tall, 152
 Look round, Taking a, 13
 Loquat, 423
 Lotus *jacobæus*, managing, 194
 Lupins, to arrange a bed of, 83
- MACGILLIVRAY (Dr. W.), his British Birds, 37
Macheranthera tanacetifolia, and culture, 155
Magnolia grandiflora propagating, 354
Malva umbellata, 220
Mandevilla suaveolens, propagating, 412
Manettia bicolor culture, 243
 Mangold sowing, 506
 Mantell (Dr. G. A.), 199
 Market gardens round London, 379
 Masters and their Gardeners, 134
Maurandya Barclayana culture, 19
 Mauritius, its sugar and gardening, 178
 McGlashen's transplanting machine, 379, 453, 476
 Measures in Covent Garden, 435
Meconopsis cambrica, 335
Medinilla Sieboldii, 82; not flowering, 152
 Melidiores, or Maladores, 94
 Melon seeds, good age for, 234; culture, 412; under rough plate glass, 509
Melianthus major, 150
 Meteorology in Mauritius, 359
 Michaelmas Daisy, hybrids, 115
 Mildness of the season, 359
Miltonia spectabilis culture, 353
 Mistletoe sowing, 114
Mitraria coccinea culture, 9
 Mushroom beds, preparing dung for, 29; modes of cooking, 169; to establish on lawn, 234; preparing, 292
 Mussel layers, 71
 Mustard, its derivation, 300
- NECTARINE (Stanwick) not hardy, 138
Nelumbium speciosum culture, 510

- Nematanthus longipes, as a show plant, 52
 Newbury Horticultural Society, 399
 Nicotiana alata, 175
 Niven, Mr., 339
 Normandy and its poultry, 111
 Normandy, 170, 273, 290
 Northampton Horticultural Show, 105; Nursery Gardens, 144
 Notes, comparing, 142
 Nuphar lutea, 135
 Nurserymen as fruit dealers, 139
 Nymphaea alba, 95; cœrulea hardy, 457
- OAK, Selsey Forest and Stephen's 355; height of the upright, 452; soil, 467
 Oat-sowing, 505
 Enothera macrocarpa and missouriense propagating, 20
 Old garden, renewing an, 412
 Oncidium papilio culture, 233
 Onions, roping, 39; (potato) culture, 174; sowing, 328; culture, 405
 Opium, its production, &c., 295
 Oranges and lemons for back wall of greenhouse, 152
 Orange-tree culture, 314; sickly, 471
 Orchard-house, fruits for, 113; Rivers', 299
 Orchard, trees for, 252; notice of early, 336; hints on planting, 338; in 18th century, 356; in Kent, 395; planting, 497
 Orcharding, its profit, 472
 Orchids, sale of, 78; culture, 233, 394; from seed, 500
 Osmaston Manor, 43
 Oxalis bowei, and other species, their culture, 124; list of, and times of blooming, 125, 134; Deppii not blooming, 252
 Oxford Botanic Garden, 180
 Oxyanthus tubiflorus and culture, 75
 Oyster layers, 71; vegetable, 214
- PALMA CHRISTI out-of-doors, 17
 Pampas grass, 96, 379; getting seed, 27
 Pansies, descriptive list of, 184, 207, 308
 Papaver argemone, and hybridum, 195; nudicaule, 215; dubium and rhœas, 255; somniferum, 295
 Paper of straw, &c., 436
 Paraguay, 96
 Parsnip culture, 385
 Paterson to Mr. Forsyth, 3
 Paul Jones, 79, 436
 Paulownia imperialis, 235
 Peach, Shanghai, 100; forcing early, 104; tree, borders, 179; pruning, time for, 194; trees, cause of decay, 317; house management, 360
 Pears cracking, 20; Hessele, and Louise d'Avranches, 23; Brown Bœurré, 24; best baking, 57; in October, 84; new seedling, 100; Louis Bonnes, 114; Louise Bonne, its history, 134; list of dessert, 193, 217; on quince stocks, 214; as wall-fruit, 275; history of, 276; gathering, 294; list of, 314; early culture in England, 315; for wall culture, 316; in Derbyshire and Northumberland, 394; effect of different stocks, 413; why gritty, 451
 Peas in October, 83; new varieties tried, 100; growing early, 127; culture, 396; from France, 457; growing early, 504
 Peat, its use and treatment, 54; charcoal for camellias, 273
 Pelargoniums (large) dying, 93; improvement in, 304; raising from seed, 383; propagating by cuttings, 404; summer treatment, 423, 442; two-year old, 462; winter treatment, 483; grafting, 423; sowing, 471; list of, 491; house for, 443; seedling growing, 447; the spot in, 502; preparing for show, 502; sowing in autumn, 509
 Petunia, its characteristics, 85; cuttings and seed, 106; soil for, 126; summer and winter treatment, 145; management for exhibition, 165
 Pheasants, rearing, 52, 391; keeping, 370; silver, a vagrant, 418
 Phlox floccosa, account of, 54
 Phyllocladus, list of species, 244
 Physalis alkekengi, 153; edulis, 294
 Phytolacca decandra culture, 93
 Picea, list of species, 285
 Pigeons, diseased throat in, 274; Antwerp carriers, 311; disease in, 314; treatment of canker in, 332; kinds to keep, 354; house, place for, 394; consequences of mixing, 471
 Piferer, the garden, 326
 Pine culture, Hamiltonian, 4, 24, 159, 201; ventilation, 24; heating, 25; propagating, 57; descriptive terms, 58; house for, 58; soil for, 58; culture, tan for, 120; weight of fruit, 123; query as to fruiting, 152; treatment of fruiting, 332; apples, shifting, 436; three best, 499
 Pinetum, trees for, 133
 Pinus, list of species, 324, 366, 403, 443, 483
 Pit for forcing, &c., 53; for propagating, 412
 Pits, management of plants in, 181; covering cold, 401
 Plants, packing for exportation, 40; their gradual development, 216; hardy in Ireland, 230; spontaneous growth of, 408
 Plectranthus concolor-picta, 82
 Pleroma elegans, pruning, 193
 Plum, Purple Gage, 21; in Derbyshire, 394; for standards, 452
 Poinsettia pulcherrima, 305; culture, 471
 Polmaise heating, 245, 252
 Polyanthus narcissus culture, 273
 Polygala Dalmatiana, 500
 Pomological societies, 298
 Pony, the Cottage Gardener's, 370, 388, 445, 488
 Poppy-worts, 195, 215, 255, 295, 375, 395, 433, 473
 Porphyrocoma lanceolata culture, 374
 Potato murrain and large produce, 2; disease, 30; autumn-planting, 33; planting in clay soil, 54; early good varieties, 54; culture, 65; planting, 73, 253, 328, 408; quantity consumed, 76; a variety not affected by murrain, 76; successful mode of culture, 77; kinds most free from disease, 106; murrain, 111; grown without leaves, 136; forcing, 208; growing, 211; failure, 234; manufacturing young, 337; experiments in its culture, 465; Malfatti's, 477; planting Ash-leaved, 506; hybridising, 510
 Pot-herb culture, 444
 Pots for training, 134
 Potting sand, 314
 Poultry, Liverpool Show, 17; mania for Cochins, 18; prolificacy of Cochins, 19; hens' nests, 19, 48; cramp in, 20; Winchester and Southern Counties Society, 22; cost of keeping Cochins, 32, 294; Andrews' Cochins-Chinas, 38; Cornwall exhibition, 38; Cochins-China Fowl's remonstrance, 49; sending to the Show, 49; prolific ducks, 53; fattening Cochins, 54; Cochins v. Spanish, 54; experiments on feeding, 68; visits to the chief yards (Sturgeon's), 69; Polands at Dominica, 73; roup, treatment of, 73; what is a pure breed, 73; North Staffordshire Show, 79; Cochins, Dorkings, and Spanish, 90; expense of feeding, 91, 94, 131, 150, 153, 192, 250, 273, 291; for laying, 94; White Shanghai, 94, 354; Ducks not laying, 94; choice of Shanghai, 94; Lovell's, 94; time for sitting, 94; results of Mr. Sturgeon's sale, 96; chief yards of England (Capt. Hornby's), 108; cross-bred, 114; Spanish, &c., 114; its literature, 115; Mowbray and Dickson on, 116; soil for, 116; colours of, 116; increased importance of, 118; Penzance poultry yards, 129, 210, 248; Cochins-Chinas, weight of, 129; laying soft eggs, cure for, 133; Silk fowls, 133; doubts about keeping, 134; cooking Shanghaes, 134; use of December eggs, 152; eggs for travelling and hatching, 152; feeding Shanghai, 152; proneness to sit, 153; ornamental and domestic (Dixon's), 155, 178; egg hatching, works on by Nolan, Richardson, and Baily, 156; Hamburg described, 156; shows, their abuses, 158; cross breeding and roup, 168; Shanghai described, 170; Dorchester show, 171; Hitchin show, 172, 233; Cochins-China, no such breed, 174; at the Mauritius, 178; Winchester Show, 187; rapid growth of Shanghai, 189, 211, 250; the Dorking, 191; Musk Duck, 192; Polands v. Hamburgs, 194, 274, 490; lot at Sturgeon's sale, 194; Great Metropolitan Show, 199, 251, 308, 369; dimensions of cocks, 210; Dorkings v. Shanghaes, 212; inflammation of egg passage, 213, 350; to prevent a hen sitting, 214, 233, 273; fencing for yard, 214, 274; points in Shanghai fowls, 214; Birmingham Show, 225, 250; dealers should not be judges, 226; broken limbs, to treat, 230; Mr. Punched's yard, 231; Bristol Show, 232; Shanghaes unrelated, 233; colour of Shanghai's legs, 234, 432; rape and linseed dust for, 234; price of Shanghai, 238, 294; white Polands with white crests, 238; Salisbury Show, 251; laced Polands, what are their characters, 252; rules for exhibitions, 256; Cochins, Dorking, and Spanish, 269; Great Metropolitan, Dublin, and Birmingham Shows, 270; white comb in Shanghaes, 272; Black Bantams, their characteristics, 273; sickle feathers in Shanghai cocks, 273; Black Shanghaes, 274, 333, 354; Silver-Spangled and Golden-Spangled Hamburgs, 274; eggs, to detect feundated, 274; arrangements at Birmingham proposed, 276; Brahma Pootra, 288, 413; disease of (Apoplexy), 289; hatching, nests, and breeding, 292; pens at shows, 292; Dorkings, their characteristics, 294; effects of long shows, 297; sales of Shanghai, 299, 436; Cheltenham Summer Show, 300; cross-breeding and use of medicine, 312; paralysed limbs, 314; Truro and Penzance Shows, 328; Dublin Amateur Show, 332; feathers, 332; breeding pure chickens, 332; comb of Dorkings, 332; roup in Shanghaes, 333; rheumatism in, 333; consequences of shows, 338; memorial to Birmingham committee, 338; dealers as judges, 347, 447; Doncaster and Honiton shows, 349; pea-fowl, 351; Mr. Wingfield's yard, 351; cross-breeding, 352; Silver-pencilled Hamburgs, their characteristics, 354; Birmingham show rules, 357; price of eggs, 360; Torquay, 368; mistakes at shows, 369; judges and auctions, 369; Spanish at Truro, 369; exhibition fever, 371, 411, 489; apoplexy and paralysis, 371; eggs, preserving, 373, 393; chicken feeding, 373; eggs, impregnating, 374; black-breasted game, 374; three eggs laid in a day, 379; different kinds of feathers, 387; Hamburgs classified, 388; Reigate show, 389; Royal Dublin, Bath, and West of England and Birmingham, 390; hints on breeding, 393; characteristics of Dorking, 393; imperfect eggs, 393; cuckoo feather, 387, 394; prize list of Royal Agricultural Society at Gloucester, 394; sale of Mr. Pott's Shanghai, 399; pencilled feather, 406; Polands and Hamburgs, their distinctions, 409; spangle defined, 409; cross-breeding, 410; influencing the sex of chickens, 411; breeding pure, 413; Shanghaes with unfeathered legs, 413; Shanghai eggs, 413; Doncaster show, 418; prizes by our Agricultural societies, 425; hints to societies, 426; bantams, their varieties, 431; Egyptian, 431; hybrid with pheasant, 432; Captain Hornby's Spanish, 432, 472; Polands, 432; Yorkshire Agricultural Society's prizes, 434; Bath and Western Counties prizes, 435; Kendal and Smithfield Club Shows, 436; cross breeds, 446; rules at shows, 447; laced versus spangled Polands, 448; on shipboard, 449; inflammation of their stomach, 450; influencing their sex, 451; crowing hen, 452, 491; Shanghai chickens since Christmas, 452; weight of Dorkings, 452; cross with pheasant, 452; egg-eating pullet, 452; lameness in Dorkings, 452; Nutt's Shanghaes, 456; Newcastle Show, 457; the laced feather, 456; beards of Polands defended, 467; egg-eating hen, 471; summer ducks, 471; sudden death of Shanghai, 472; laying soft eggs, 472, 492; weight of Shanghai cock, 477; Bath and West of England Society's rules, 477; Laced Polands, 486; on shipboard, 487; egg-bound, 489; frost-bitten, 491; keeping breeds distinct, 492; white Bantams, 492; profits of keeping, 492; Spanish, 492; Bath and West of England exhibition, 494; sale of, 496; Great Northern show, 496; Bearded Polands, 507; egg-eaters, 509, 510; size of house required, 509; Egyptian, 509; Bolton Greys, 510; cross between Shanghai and Dorking, 510; shape of egg, 510
 Pouretia (Puya) longifolia, 199
 Preserving specimens of animals, 372, 391, 432
 Prices in 1675, 37
 Primroses (Chinese), how to grow superior, 458
 Primula Palustris, 459
 Propagating tender plants, 321
 Protecting crops, 265; fruit-trees, 318; plants, various modes of, 416, 419
 Protection from frost, 455, 456; to early forced vegetables, 457
 Psoralea esculenta, 158
 Pterocarpa Caucasia, 60
 Pteris holoserica, 20
 Puya zeylanica, 83
 Pyrethrums, white, culture, 234
- QUINCE, mildewed, 72
- RABBITS, liver complaint in, 54; importation of, 119; long-eared, 253
 Rain, quantity fallen, 199
 Ranunculus planting, 471
 Raspberries, soil for, 234
 Ravens and their young, 469
 Redbreast's familiarity, 19
 Red spider, destroying, 412
 Rhododendron ciliaris, hybridizing, 458
 Rhubarb forcing, 114, 146, 248; earliest and most profitable, 252
 Rhynchospermum jasminoides, 421
 Ridging, its importance, 149
 Rochea falcata, 314
 Rogiera amœna, 420; Roczii, 458
 Rolleston Park, 44
 Romeria hybrida, 433
 Rookery, to establish, 33
 Rooks, 52

Rooms, showing plants in, 61
 Root storing, 65
 Root crops, removing leaves from, 236; digging for, 408
 Rosa microphylla culture, 281
 Rose and Ivy, 94
 Roses arranged according to their colour and growth, 10; protecting Tea-scented, 33; on turf, 54; renovating moss, 54; pegging down, 54; soil for, 73; newly-bedded mismanaged, 73; on back wall of forcing-house, 106; pruning budded, 113; climbing, 113, 451; Devonensis, 153; management of Lamarque, 173; pruning standard Chinese, 193; felicitate perpetual, 253; pruning climbing, 374; planting cuttings, 413; leaves mildewed, 451; near London, 452; from eyes, 509
 Rotation of crops, 149
 Rustic seats and gates, 20

SAIL-CLOTH for sheltering, 54
 Salading, lists of, 342, 500
 Salix, its species, 36
 Salt, goat's fondness for, 339
 Salvia patens, wintering its roots, 73; hardy in Ireland, 152; sowing, 432
 Samphire pickling, 54
 Saponaria Calabrica culture, 374
 Scotia speciosa, 472
 Scotland, state of crops, 38
 Scrapers, garden, 218; moveable garden, 410
 Screen of evergreens, 491
 Sea-kale, forcing early, 145
 Selago distans culture, 284
 Sewage, removing its smell, 114; how to use, 134; unfermented, and irrigating with, 153
 Shaded border, plants for, 234
 Shankling, to prevent, 248
 Sheldrake and its haunts, 50, 70
 Sheep buying, 153; barking trees, 452
 Shows, list of, 4, 24, 38, 57, 79, 100, 120, 136, 159, 178, 201, 218, 238, 258, 279, 300, 318
 Shrubs, list of hardy, 94
 Silk, its growth in England, 77
 Sinclair (Sir J.), 77, 98, 136
 Siphocampylus microstomus culture, 341
 Skimmia japonica, 82, 220
 Smith (Sir J. E.), to Mr. Forsyth, 36
 Snow as a protection from frost, 456
 Soil, what is a poor, 113
 Soils for fruit-trees, 179
 Solandra levis, 82
 Sonerila orbicularis, 221; japonica culture, 341
 Song Birds (British), 132
 Soot as a manure, 273
 Sowing small seeds, 510
 Sparaxis propagating, 53
 Sparrows, out-manceuvring, 253
 Spinsters, a word to, 367
 Sports in plants, 216

Spring crops, preparing ground for, 344
 Spud (a useful garden), 371
 Stauntonia latifolia, a new hardy evergreen climber, 421, 471
 Stoneleigh Abbey, 63
 Stones beneficial to light soil, 373
 Stove for pines, 4; plants for exhibition, list of, 35; in greenhouse, 303
 Strawberry, two new varieties, 100; forcing early, 102; forcing those in bloom in open ground, 274, 279
 Structures, gardening, 500
 Styvechale Hall, 63
 Suburban gardens, forming, 87; walks and edgings for, 107
 Succulents in the Oxford Garden, 181
 Suffolk Heaths, 130
 Sulphur, on hot surfaces, 273; symptoms of excess of, 413
 Sweet Pea, cuttings of roots, 472

TACSONIA SANGUINEA, 315
 Tailor, the poor, 246
 Talc, as a substitute for glass, 138
 Taste, jottings about, 27
 Taxodium sempervirens, 20; in bloom, 458
 Tea seeds, 459
 Tender plants that may be dormant in winter, 104
 Tetratheca pruning, 274
 Thunbergia alata in the open air, 60
 Titlark, its treatment, 132
 Tobacco, cultivating and harvesting, 31; plants producing, 175
 Torenia asiatica sickly, 114; culture, 304; propagating, 412
 Training with eyed nails, 314
 Transplanting large trees, 238; M'Glashen's plan, 379, 453
 Trees before a house, 20; fast growing, 113
 Trellis, climbers for, 20; table, for fruit, 420
 Tropaeolum tuberosum, its produce, 174; tricolorum, 174; tricolorum shedding its leaves, 193; Lobbianum varieties, 230; Lobbianum, pentaphyllum, and tuberosum culture, 242; tricolorum culture, 311; roots, cooking, 412
 Trymalium odoratissimum, 500
 Turnips, produce per acre, 236; sowing, 507
 Tying-down training, 273

UNITY of expression in gardens, 27

VANDA CŒRULEA, 81; influence of heat on, 123; suavis, 220
 Vegetables, imported, 457; borders, turfing, 471
 Ventilation, 252
 Veranda, plants for, 394
 Verbenas, damping off, 152; mode of preserving, 194; propagating, 471
 Veronica speciosa in room, 234; Andersonii and speciosa culture, 283

Victoria Regia at Glasgow, &c., 253
 Village Feast, 209
 Vinery, management of, 339; choice of vines for, 412; heating a small, 510
 Vines, culture, 20; at Bishop Stortford, 30; admitting stems, 31; for cool greenhouse, 54, 393; in pots, 72; border, 94, 152, 194; forcing early, 101; removing, 106; bark removing, 152, 194; dressing for, 253; mildew, its prevalence, 258; grafting, 274; in pots from eyes, 274; disbudding, 339; stopping, 340; shoots drooping, 413; forcing, when to begin, 457; dressing, 472; still unpruned, 472; blighted, 509; gnawed by a dog, 452
 Violets their history, 35; Russian Superb, 36; modes of cultivating different kinds, 162

WALKS in small garden, 93, 107; their classification and arrangement, 397; in orchard, 498
 Walls, conservative, and heated fruit, 183; forming a conservative, 264; furnishing, 274, 305; plants for preservative, 343, 384, 422, 461, 503; for fruit, 497; flowers, &c., for north, 509, 510
 Wall-trees unfruitful, 274
 "Wanting for nothing," 128
 Ward's case, plants for, 274, 491
 Water for orchard, 498
 Water lilies, 95; yellow, 135
 Watsonia fulgida in border, 193
 Weather during last fifty years, 486
 Wedgewood, John, 357, 377
 Weeds, modes of killing, 306
 Weigela rosea culture, 9; pruning, 193, 394
 West Indies, useful plants for, 417
 Westringia Dampierii culture, 262
 Wet days, work for, 29
 Wet season, influence of, 165, 265
 Wheat, its origin, 215; sowing, 300; sowing spring, 485
 Whitley Abbey, 63
 Widow indeed (The), 47
 Wilderness, shrubs for, 181
 Wild Flowers (British), 21, 55, 95, 135, 195, 215, 255, 295, 335, 375, 395, 433, 473; profit from, 214; walks after, 300
 Window gardening, points in, 42
 Wintering plants, easy mode of, 234
 Wireworm, mode of destroying, 330
 Woodlice, destroying, 402
 West Park Gardens, 143

YEAR, close of the, 264
 Young, Dr. G., 417
 Yuccas, new mode of culture, 6; list of, 7

ZEPHYRANTHES ATAMASCO culture, 393
 Zichyas, list of and culture, 84
 Zinc, for garden pots, 62
 Zygopetalum Mackayi, culture, 233

WOODCUTS.

	PAGE
Camptosema rubicunda	1
Berberis vulgaris	21
Front light of Vinery	31
Commelina scabra	35
Epimedium alpinum	55
Flower-Garden plan	67
Oxyanthus tubiflorus	75
Nymphaea alba	95
Grindelia grandiflora	115
Titlark	132
Nuphar lutea	135
Flower-Garden plan	147
Machaeranthera tanacetifolia	155
Nicotiana glauca	175
Cucumber Pit	187

	PAGE
Papaver argemone	195
Papaver nudicaule	215
Garden scraper	218
Mr. Punchard's Poultry Yard	231
Paulownia imperialis	235
Papaver dubium	255
Tent for Exhibitions	267
American garden plan	271
Ceanothus rigidus	275
Flower-Garden plan	289
Poultry basket	292
Papaver somniferum	295
Tacsonia sanguinea	315
Meconopsis cambrica	335
Salecy Forest Oak	355

	PAGE
Glaucium luteum	375
Label	386
Hot-water apparatus	387
Glaucium corniculatum	395
Pencilled feather	406
Moveable garden scraper	410
Begonia Thuaitesii	415
Flower-Garden plan	427
Romeria hybrida	433
Hot-water apparatus (gas-heated)	434
Abelia uniflora	453
Laced feather	465
Chelidonium majus	473
Cinchona calisaya	493

WEEKLY CALENDAR.

M D	OCTOBER 7—13, 1852.	WEATHER NEAR LONDON IN 1851.				Sun Rises.	Sun Sets.	Moon R. & S.	Moon's Age.	Clock bef. Sun.	Day of Year.
		Barometer.	Thermo.	Wind.	Rain in In.						
7	TH Beech leaves fall.	29.785 — 29.669	60—40	S.W.	09	13 a. 6	23 a. 5	11 18	24	12 15	281
8	F White Poplar leaves fall.	29.955 — 29.833	59—32	W.	13	15	21	morn.	25	12 32	282
9	S Hazel yellow.	29.924 — 29.802	60—56	S.	—	16	18	0 31	26	12 48	283
10	SUN 17 SUNDAY AFTER TRINITY. Cam. T. b.	30.168 — 29.535	68—46	W.	—	18	16	1 52	27	13 3	284
11	M Old Mich. Day. Oxford Term begins.	30.224 — 30.188	68—53	S.	—	20	14	3 16	28	13 18	285
12	TU Fieldfare comes.	30.283 — 30.274	68—54	S.	—	21	12	4 42	29	13 33	286
13	W Elder leaves fall.	30.129 — 29.989	62—54	S.W.	04	23	10	sets.	☉	13 47	287

METEOLOGY OF THE WEEK.—At Chiswick, from observations during the last twenty-five years, the average highest and lowest temperatures of these days are 61° and 43° respectively. The greatest heat, 75°, occurred on the 13th in 1845; and the lowest cold, 26°, on the 13th in 1850. During the period 84 days were fine, and on 91 rain fell.

RUBY-FLOWERED CAMPTOSEMA.

(*Camptosema rubicunda.*)



PLANTS of this comparatively new genus have been likened to, and called, Kennedias, in gardens. In their outward appearance, and in their general habit, they much resemble some of the species of Kennedyia, Zichya, and Hardenbergia, yet, when they are examined botanically, they exhibit a wide departure from that group, and come nearer to Canavallias and Diocleas. The genus was founded by Hooker and Arnott, and the name derived from *kamptos*, bent, and *sema*, a standard, alluding to the form of the

flower branches. Instead of *Papilionaceæ*, as formerly, all the pea-flowering, and all plants, whether with pea-flowers or not, that bear their seeds in pea or bean-like pods, as the Acacias, are now called Leguminous plants, because such pods, in the language of botany, are called *legumes*; and to get rid of the old associations about pea-flowers, or *papilionaceæ*, leguminous plants are now called *Fabaceæ*, or Beanworts. This species of *Camptosema* is a native of Brazil—a very gay climber, with ruby-coloured, pea-like flowers hanging down in long racemes, and producing a fine effect. It requires the heat of a stove to make the most of it, but a warm conservatory will probably be found sufficient for it. It was first introduced to the German gardens four or five years ago, under the name of *Kennedyia splendens*. *Leaflets* smooth, milky-green beneath; *racemes* of flowers about nine inches long, drooping; *calyx* with two small bractes at the base, somewhat two-lipped, and from 4 to 6 lobed; *petals* nearly equal, deep ruby-red in colour, the largest rather bent back, clawed with two blunt teeth at the base of the lamina; other petals clawed, each with two blunt teeth at the base of the lamina. It is in the Diadelphia Decandria of Linnæus. The *stamens* are in two groups, nine and one.—*Botanical Mag.*, 4608.

Culture and Propagation.—From what I have learnt about this new fine climber, I have no doubt but that it will succeed well where the *Beaumontia grandiflora* and *Stephanotis floribunda* thrive and flower. It is true the latter will do just as well in the Calcutta orchid-house, the common stove, the early vinery, and the warm conservatory; but the *Beaumontia* will not do in either heat nor cold—that is, in a stove or in a greenhouse—but in a place intermediate between the two; and such intermediate temperature, I am quite sure, is best for this *Camptosema*; and, being a strong grower, it must have sufficient head-room to extend itself freely before it will flower much. Cuttings from small side shoots is the nursery way of propagation, but, for private use, make layers of long shoots of last year, in the spring, and so get full-grown plants at once. D. BEATON.

No one better than an Editor knows the impossibility of acting so as to please everybody, and even in enlarging our paper, at a certain expenditure of several hundreds of pounds, and with a total uncertainty as to any remunerative return, we are quite sure of displeasing some of our readers. We shall regret the displeasure of even one of them, but conscious of the soundness of our intentions, we hope all things, and pursue our way. That way has been known for four years to our readers, and we can assure them that “the old path” will not be diverted, but only widened. We have felt that for some time, Poultry, and other intelligence, though strictly within our original purpose, have trespassed upon space that should be devoted to Gardening, yet, Poultry, Bees, the Aviary, and Farming, are subjects on which a large proportion of our subscribers demand from us information. Then, again, we have been asked not to print advertisements so that

these must be bound up in the volume; whilst other, and very numerous, parties have required, that to these advertisements we should give additional space.

We are also fully conscious of the truth of an opinion expressed in a recent number of *The Quarterly Review*, that the contents of our little work are as suitable for the cottage of gentility, with double coach-house, as that usually tenanted by the labourer; but while we admit thus much, we well know it is, and has been successfully, our aim to write so as to be clear and useful to all. We have the best of all evidence, that the man of education, as well as the self-taught labourer, are satisfied with our pages; and although we shall so far meet the criticism of our Quarterly contemporary as to add to our present title that of THE COUNTRY GENTLEMAN'S COMPANION, and while it will be our continued study to cultivate the good will of that important class, we shall still pursue our course unaltered, still study to

be THE COTTAGE GARDENER, but with its usefulness again increased. In testimony of this, and we have other new stores of information placed at our disposal, we offer the present number as the best of evidence.

IN our last number we stated our conviction that the days of the Potato are not yet brought to a close, but that we look forward with confidence to a recurrence of that state of health in the plant, when unmurained crops will be usual, and murrained crops rare. We stated, also, our reasons for thus hoping, and one of those reasons is, that, even in the worst murrained of years, we find many instances of crops entirely exempt from the disease. This exemption is not of rare occurrence, and though the circumstances occasioning such exemption are not with certainty known, yet the exemption demonstrates that such circumstances exist. If they exist, they can be ascertained; and, when ascertained, the days of safety to the potato will be restored.

One such instance of exemption has been communicated to us by one of the best practical horticulturists we know—Mr. Weaver, gardener to the Warden of Winchester College. He says—"Early this spring I received thirteen very handsome potatoes from a gentleman of this neighbourhood, who is fond of having good potatoes at his table every day. They are called the *Dalmahoy Seedling*, being raised by Lord Morton's steward, at his lordship's seat, Dalmahoy, near Edinburgh. They were all very sizeable—from 3 inches to 3½ inches, the widest way of them—and I determined to plant them whole. But where could I plant them? was the next question, as nearly every inch of our ground was under crop at the time. At last, finding a small plot alongside some globe artichokes, a line being set down about five feet wide from the artichokes, here I planted the sets, two feet six inches from set to set in the row. This was done on the 13th of March. The row stood clear of everything excepting a few weeds; the plants were not earthed up at all, and I believe nothing was ever done to them from the time they were planted until they were taken up about the middle of August. On taking up the first root, seeing the tubers so numerous, induced me to count them. The following is the number found at each root:—58, 62, 47, 33, 54, 41, 45, 48, 29, 30, 32, 57, 47. I took them up myself, and, I believe, every one of them: the sample very fine for the season. After they were taken up about six or eight days, they were looked over, and all diseased ones removed, which was nearly one-third of the bulk. This has been found the case in all our general crops that were in the ground so late as the middle of August.

"One kind, which we call the *Herefordshire Early Purple*, is a kind which we generally begin taking up for use about the second week in July, having done so for many years. Wanting the quarter for another purpose, these were all taken up by the 20th of the month, and stored away in the potato house, where most of them are at this time. In these we have not seen a

diseased potato at all this season, from the first to the present time.

"Another favourite, called *Heigh's Norbury Seedling*, a beautiful potato, allied to *Walnut-leaved Kidney*, and a great bearer, was taken up on the 1st of August, and scarcely any diseased ones have been found among these from first to last. The same observation applies to *Rylott's Flourball*—scarcely any diseased, and taken up at the same time. *Luker's Oxonian*, taken up at the same time, nearly one-third diseased. *Forty-folds*, about four bushels of which were taken up at this time, were much more free from disease than those which remained in the ground to the middle of August. Among these last taken up, full one-third were diseased. And in a quarter of *York Regents*, which were somewhat shaded by trees, upwards of two-thirds were diseased."

We may add, that Mr. Weaver entirely coincides with us in recommending planting none but early kinds, planting whole sets, and planting early.

COVENT GARDEN.

THERE were many fine gardens in London once; but what Mr. Dickens calls "The Great Invasion" has so squeezed and circumscribed them, that, yielding to "the pressure from without," there is nothing left of them now but their names. We can imagine in our own minds what these old gardens were like, with their trim hedges, clipped "greens," and "allies artly devised in the same;" to say nothing of "the proper knots," as flower-beds, which would have supplied, with credit, designs for any "Knitting, Netting, and Crochet Book," even of the present day. We can imagine, too, what the old gardeners were like, with their long beards, Elizabethan ruffles, and high conical hats. These are what some people call "the good old times;" but they have all passed and gone, and with them the good old gardens, and the good old gardeners, of London, leaving scarcely even a trace of where this one "grafted all sortes of trees," or that other practised "the right ordering of all delectable and rare flowers."

The only place of this kind, bearing the name and aspect of what it once was, is COVENT-GARDEN; and, as if unwilling to be banished from their former haunts, it would seem as if the ghosts of these old times still met and held their midnight revels there—for during the time that mortals sleep, there are produced, in this once fertile spot, such fruits, and flowers, and esculent plants, as would excite the incredulity of those who have not seen them. It would astonish some of our country friends who have never witnessed such a sight as is there exhibited every Tuesday, Thursday, and Saturday morning, to see the ponderous cabbages, the unmeasurable carrots, the enormous celery, the gigantic rhubarb, the snowy turnips, and the curly parsley! produced as if by fairy power, or coming from, we hardly know where.

It is of COVENT-GARDEN that we intend weekly to furnish the readers of THE COTTAGE GARDENER with a report. Our object shall be to notice everything as it

comes into season, with such comments and remarks on the most important productions as we conceive will be interesting. In this way they will have a sort of calendar of horticultural produce, as well as a good indication of what to grow and what to avoid. These ghosts of whom we have spoken know well, and none know better, what is worth growing, and what suits best the taste of this great world of London.

During the past week there has been an abundant supply of all kinds of fruit. APPLES are very plentiful, and range in price from 3s. to 8s. per bushel. *Fearn's Pippin* has made its appearance as gay and ruddy as ever; this is much grown by the market-gardeners of London, for, besides being a good market apple, it is a great bearer, and its fine, brisk, and sugary flavour render it suitable either for dessert or kitchen use. *Golden Pippins* and *Ribstons* are "in," and there are still a few *Kerry Pippins* left, but they are very small and very shrivelly. PEARS vary from 3s. 6d. to 7s. 6d. per half-sieve,* and are also very plentiful; besides a number of nondescript varieties, there are several of the best sorts already in perfection. *Williams' Bon Chrétien* are going out; they are getting very yellow and very "sleepy;" these have been very plentiful this season, more so than that respectable individual, "the oldest inhabitant," ever remembers. *Hessle*, not *Hazel* nor *Hessel*, has also furnished a large supply, but is going out, and giving way to the *Autumn Bergamot*, *Beurré Capiaumont*, and *Marie Louise*; as these will be in season for some time to come, we shall have an opportunity of commenting on them on a future occasion. There are some very fine *Gansel's Bergamots*, from Guernsey, for which the epicure must give from 3s. to 5s. per dozen. The *Jersey Gratioli* has also appeared during the week; this is a most delicious pear, but very little known: everybody who wishes to plant six trees should have this one of them; we shall speak of it again. *Louise Bonne of Jersey* has been in for some time; this also is a very fine and very beautiful autumn pear, which ought to be in every collection; it may be said to come in between the *Williams' Bon Chrétien*, *Jersey Gratioli*, and *Marie Louise*. PLUMS of inferior baking kinds, such as *Muscle*, and other hedge varieties, are plentiful still, at about 2s. 6d. to 3s. the half-sieve. *Damsons* are also very plentiful, at the same prices. Among the dessert varieties, *Coe's Golden Drop*, and some small shrivelled *Greengages* are all that are to be seen. Of PEACHES, the *Late Admirable*, and a few *Catherines*, are making their appearance; but we would rather have a good *Jersey Gratioli*, or *Marie Louise* pear, than all the *Catherine* or other late peaches the garden can produce. GRAPES, both home and foreign, are plentiful. *Black Hamburgs* constitute the former, and fetch according to quality and colouring, from 2s. to 5s. per pound. The foreign are from 9d. to 1s. per pound.

Many fruits which are merely enumerated in the present notice, shall be treated of at length, as we have occasion to refer to them in subsequent reports. H.

* Half-a-Sieve contains three-and-a-half gallons.

FORSYTH MSS.

IN our last notice of LIEUTENANT PATERSON (vol. viii. page 378), he was at Norfolk Island, in the May of 1792, and there, and at Port Jackson, he continued until nearly the close of the century, but before that he had become Captain, in the New South Wales Corps. He then returned home, but did not remain there long, for under the date of February 22nd, 1800, and from Port Jackson, there is this letter from

MRS. PATERSON TO MR. FORSYTH.

We arrived here on the 4th November, after a tolerable speedy voyage of less than five months, which was a fortunate circumstance for us, as the ship was excessively uncomfortable, and ill calculated for passengers, and besides very leaky. We put into St. Salvador, on the coast of South America, to refit, from which place, until we arrived here, we had constant gales and bad weather. In one of these severe storms Col. P. was nearly killed by a fall in the cabin, being very much bruised, and three of his ribs broken. He is now, thank God, quite recovered, and has been lately exploring the banks of the river Hawkesbury, principally for coal, which was not found just at the spot where he expected; but there is plenty in other situations. He was amply rewarded, however, for his trouble, by discovering many new plants, and in visiting the different settlers in that neighbourhood. The crops of grain those farms produce are wonderful, but, notwithstanding the fine country and climate, the colony is in a most wretched state, from bad management. An active, able man, is much wanted here, as Governor, and that soon, or I fear it will take a long time to bring it about again. I send this letter by Mr. Cover, one of the unfortunate missionaries sent out in the Duff. He is a worthy man, and can give a correct idea of this place, having been here above twelvemonths. He will also be able to give you every information respecting that unsuccessful mission. The cultivation of the vine in this country is very much neglected, from the two or three last seasons having failed. Fruit-trees, particularly apricots and peaches, thrive uncommonly well, especially the latter, which in general produces fruit the second year from the stone. Col. P. would have written to you himself, but is very much engaged in arranging regimental business to send home.—E. PATERSON.

He returned to the colony not only as Colonel of his regiment, but as Lieutenant-Governor, and continued to retain that office until his final retirement. His last letter among these manuscripts is dated from Sidney, October 13th, 1800.

COLONEL PATERSON TO MR. FORSYTH.

Governor Hunter being about to quit this country gives me an opportunity of saying that both Mrs. P. and myself are in good health.

Since my arrival in this country I have had very little time to pursue my favourite amusement, what with the duty of the corps, and the constant watch we are obliged to keep over the United Irishmen that have been lately sent to this colony. We have discovered several plans that were in great forwardness to subvert the government, and to put every one to death that would not join them.

On a committee (to investigate the business), of which I was one, it clearly appeared that their plan was to have seized on a detachment of soldiers doing duty at Panamatta, in the time of Divine Service, and to have attacked us at head-quarters. We fortunately discovered their diabolical intentions the day before it was to have been attempted, and, from their observing our preparations, they did not assemble; but we found several of their ringleaders. Some of them have been punished, and a party of them sent to Norfolk Island.

There are three of our officers that return to England by this conveyance; one of them, Captain Johnston, is a prisoner under my arrest. As Governor Hunter would not allow a court-martial to try him in this country, the evidences are taken on oath, and sent to the commander-in-

chief. I shall be anxious to know the result. From all these circumstances you will easily conceive that my situation in this country is not very pleasant.

He retired from New South Wales in the spring of 1810, and among the deaths recorded in that year, we find this entry. "June 21st. At sea, on board His Majesty's ship *Dromedary*, Colonel William Paterson, Lieutenant-colonel of the 102nd regiment, F.R.S., Member of the Asiatic Society, and many years Lieutenant-Governor of New South Wales, from which colony he was returning to England in the command of the 102nd Regiment."

The following is a list of the *Horticultural and Poultry Shows* of which we are at present aware. We shall be obliged by any of our readers sending us additions to the list, and giving the address of the Secretaries.

HORTICULTURAL SHOWS.

- BURY ST. EDMUNDS, Nov. 26 (Chrysanthemums). (*Sec.* G. P. Clay, Esq.)
 CALEDONIAN (Inverleith Row), Edinburgh, Dec. 2.
 HAMPSHIRE, Nov. 18 (Winchester). (*Sec.* Rev. F. Wickham, Winchester.)
 LONDON FLORICULTURAL (Exeter Hall, Strand), Oct. 12+, Nov. 9+, 23, Dec. 14+.
 NORTH LONDON, Nov. 23, Chrysanthemum.
 SOUTH LONDON (ROYAL), Oct. 14+, Nov. 11+, Dec. 9+, 16.

POULTRY SHOWS.

- BIRMINGHAM AND MIDLAND COUNTIES, 14th, 15th, 16th, and 17th December.
 BRISTOL AGRICULTURAL, December 7th, 8th, and 9th. (*Sec.* James Marmont.)
 CORNWALL (PENZANCE), about a week after the Birmingham. (*Secs.* Rev. W. W. Winfield, Gulval Vicarage, and E. H. Rodd, Esq.)
 DORCHESTER, Nov. 18th. (*Sec.*, G. J. Andrews, Esq., Dorchester.)

† For seedlings only.

PINE-CULTURE: THE HAMILTONIAN MODE.

WE have, during the last few months, received so many queries, or heard inquiries about Pine-culture, from persons of moderate means, who wish to indulge occasionally in that luxury, and occasionally to make the fruit, by sale, pay the expenses incurred, that we think it will be but an act of justice to take up the subject in a step-by-step way; the dryness, or tedium, necessarily attending this course in the eyes of the experienced, will, we hope, be excused for the sake of the class alluded to. Too much generalisation befits not persons of this caste; they want the very alphabet of culture itself; and to make ourselves useful, we must, to use an apposite saying, "begin at the beginning."

As much confusion has continually arisen from a jumbling together the pot and the open-soil modes, we must, in this series of papers, confine ourselves to the open-soil, or Hamiltonian mode of culture, believing it to be the very best of all for the amateur; being the easiest to learn, on account of its extreme simplicity, and requiring so small an amount of labour and attention. It is somewhat fortunate that the subject should force itself at this period upon us, when, of all others, perhaps, the least advice is required in other affairs.

STRUCTURE FOR PINE-CULTURE.—We come here to the consideration of the form, the angle, or roof pitch, the glass, the interior fittings, &c., each of which will be handled in due course. Having much faith in our

friend Hamilton, whose long experience in this matter, to say nothing of his being the originator of this system, highly qualifies him to offer advice, we have written to him on the subject, in order to see if he is prepared, by subsequent experience, to confirm what he had previously laid down in his useful book. He has most kindly and fully answered the inquiries we had to make, and also permitted the use of his name, if necessary.

Mr. Hamilton has, within these four or five years, built a new house for his pine system; and it will be well to give a detail of its character. It is a span-roofed structure, running east and west, thus presenting a south roof and a north one. The pitch of the roof is three-and-a-half inches to the foot, the length of the house fifty feet, and the breadth fifteen feet. There is a walk up the centre, beneath the ridge, of two feet in width; a bed of five feet on either side, and a trench, or cavity, eighteen inches, front and back, for the piping. This house holds one hundred plants, and, according to friend Hamilton, each plant ought to produce one full-sized fruit annually, of some five to seven or eight pounds—to fix a weight for the purpose of enabling our readers to form a calculation. Of course, it will be understood, that whilst the weight here assumed would be too much for such as the Queen section, so, in like manner, will it be below the standard for such as the Providences, Envilles, Cayennes, &c.;—thus much to obtain a clear view of the question. To return to the digressive point—the external character and dimensions of a house proper for this system—we come now to the mode of heating. "Each bed," says Mr. H., "would require two pipes, in order to equalize the heat at the roots of the pines; two would be far better than one of greater calibre, for it is not a high concentration of heat at one point that is requisite, but a steady and given amount equally diffused. Moreover, it will be seen, that in hot-water heating, although a circulation *may be* established in one pipe or tank, yet it would be necessarily sluggish; and a return pipe to the boiler ensures a lively circulation, in addition to the end in view—the equalization of the bottom warmth."

Thus much for bottom or ground-heat; now for atmospheric warmth, for which *special* piping is requisite. Mr. H. says there should be two pipes back, and two in front, that is to say, a flow and a return belonging to it. It will here be seen what value is to be attached to the idea of growing pines out-of-doors, in Britain, like so many artichokes. When such is well accomplished, rents will assuredly rise, for some thousands of acres will be needed for vineyards and pine-gardens, for the demand for both will be enormous.

Thus it will be seen, that eight parallel lines of piping are considered requisite by Mr. Hamilton in such a house, and if pines are to be grown in the highest degree of perfection of which they are capable at any season, we join in Mr. H.'s opinion. The beginner in pine-culture must here observe, that the pipes to heat the soil are no more than an equivalent for the loss of tan, or other fermenting material, so that such may be fairly left out of the question of expense; for although, in the event of tan-yards being close at hand, the bottom-heat from that source might be obtained at a cheaper rate, yet, when the extra labour and uncertainty are taken into consideration, a certain loss in the end may be counted on. When tan has to be drawn half-a-dozen miles, we consider the proceeding most preposterous, according to the old adage, "penny wise and pound foolish;" those, however, who do not care about winter-pines, but would rest content with a good lot of such as Queens, Providences, and Envilles, from June to October, may succeed with one-half of the piping for warming the air of the house. The bottom-heat piping, nevertheless, the same as before stated.

To return to Mr. H., he says, "my boiler is at one

end of the house, in the centre, and outside. Immediately opposite to it inside, I have a reservoir, or iron pan, of about two feet in depth, by half-a-yard square, and this has six pipes attached to it." It will be here seen that the reservoir is but a centre, common to all the pipes, which all take their flow here, and here deliver their return. This, we suppose, is partly to save the expense of what are termed elbow-joints, and other complex affairs. In this description we are not quite sure that we understand Mr. H.; if, however, any error should creep in, we shall soon get it rectified. Mr. H.'s words are these, "the reservoir will require six pipes attached to it, so that the pipes which heat the air of the house can be plugged or stopped at any time, when only bottom-heat is requisite. This answers much better than valves." We saw Mr. H.'s house about twelvemonths since, and witnessed his thus turning off the flow, which he did in an instant, by merely thrusting a roll of coarse cloth into the advance pipe.

Having thus far followed Mr. Hamilton's plans pretty closely, we may be allowed a few comments as we proceed. In the first place, it does seem matter of astonishment, that a practice so simple, and consequently economical, so much in accordance with the habits of the pine, as stamped in indelible marks by nature's own impress, should not before this have become more general. What said Pope?

"Truths would you teach, and save a sinking land,
All hear, none heed you, and few understand."

And so it has ever been with inventions which carry a great amount of simplicity in the face of them; they pass unheeded by the majority of minds for want of the appearance of that degree of elaborateness, which, in fact, is the bane, instead of the true merit of most inventions. In speaking thus, we do not wish it to be inferred that the Hamiltonian mode ought to supersede all others; by no means. There are cases in which the pot mode may be more desirable, inasmuch as the pines may, with facility, be removed to a cool room in the pot, when necessary to retard them for particular purposes; and, indeed, it is still a question whether the Hamiltonian mode is equally applicable to all kinds; that it suits the Black Jamaica, or what is termed Montserrat by some, is undeniable. This pine, at least, seems quite at home under this treatment; and as a pine for general use, and especially for winter, it will be long, we think, before it is superseded; albeit, the rising popularity of the Cayennes threatens hard. We may here offer an opinion about the form of the house, which, indeed, is the first thing to begin with. Mr. H., it has been seen, is an advocate for span-roof houses, running east and west. Now, we really do not see why this mode should hold such a strong position in the minds of our practical men. "Speak well of the bridge that carries you safe over," is a trite maxim, and doubtless will apply to the case in hand; but a too stiff adherence to established modes is but too apt to assume a pertinacious character, and to prove a barrier to progression, which, in the most unmistakable manner, is the order of the day. Why not north and south? Pines, it is said, occasionally enjoy a little shading for three or four hours during bright and hot days, and the mid-day sun can very well be dispensed with on such occasions. But to build span-roofs with a southern facing, is to set a trap to catch all the mid-day rays possible. Sir Joseph Paxton, breaking through the trammels of prescription long since, shewed by his ridge-and-furrow-roof that there were more ways than one of building houses. The ridge-and-furrow of course is simply a multiple of the span-roof, with an eastern and western slope, or in other words, a morning and an evening side. Now, if it can be shown that a half-day's sunshine will suffice for pines, whether that half-day be an eight to twelve o'clock affair, or a twelve to four o'clock, why the rest of the question

would seem to follow as matter of course. We have talked over this subject with several first-rate men at various times within the last half-dozen years, and have almost invariably found them with a latent desire to break from southern slopes, "willing to wound but afraid to strike." Not every one, however, who can conceive a project carrying promise of advance, has the power to shew forth his conceptions in real bricks and glass.

To sum up, then, as far as the roof question is concerned, we may be permitted to offer our impression, which is, that it appears tolerably certain that the southern slope may be departed from in the case of pines, and exchanged for a morning and evening side, as in a span running north and south, as to its longitudinal direction, or, indeed, to some other points of the compass, as the case may be; and that much latitude may be fairly given in this respect, the pinery giving up a point occasionally to existing circumstances, perhaps as an adjunct to the villa or to other structures.

But if a span-roof running east and west *must* be adopted, we think that some little change in the modification of the interior fittings might be resorted to with advantage. For instance, it is a matter of principle that an equality of light should be enjoyed by the pines; those on the north side of the walk should have an equal chance in that respect with those on the south bed. To effect this, the bed on which they stand must necessarily be somewhat higher. Admitting, then, a span-roof perfectly equal in dimensions as to the exterior, we would have the back bed half-a-yard, or nearly so, higher than the front, or, if you please, the front bed half-a-yard lower; all this amounts to the same thing. In such a case, the first and ruling principle would be, to pay a due regard to the ordinary ground level outside; the front bed should be so placed as to present every portion of the foliage to the solar rays, even in the depth of winter. This done, the lower the whole structure was sunk below the ordinary ground level the better, according to our ideas; inasmuch, as the farther this point is carried out, the more the structure would prove self-protecting—a great matter in economising fuel; and every gardener knows that the use of fuel in the dull winter months, or, indeed, at any period, is a necessary evil, to give it a hard name. But not only is a proper economy involved in this arrangement, but the very health of the pines.

There is still another consideration as to the roof question; and, as we are simply throwing out hints for the consideration of those about to embark in pine-culture as a profitable investment, it will be well, perhaps, to offer suggestions with freedom, and to make our comments keep pace with the order of the subject. In pursuance of this, then, we would say, if a span-roof, running east and west—are both sides of the span obliged to be equal? In thus widening the question, we shall give a free scope to a full examination of the whole subject. As the south front is too apt to admit of too great an amount of the solar rays, why not make it less in width, say as two to three? Many other remarks might be offered on the character of the roof, but as they interfere too much with the line of our subject, we must postpone them until we can offer a chapter on roofs. The structure, then, should be so far sunk below the level, as that the front sill of the sashes is but above that level; other parts will follow as matter of course. As to glass, Mr. H. has omitted to mention it in his correspondence; but before closing this subject, we will take care to ascertain this, which, with anything else that may arise, together with omissions, &c., will be introduced at the conclusion. It seems probable, in the event the house having an east and a west roof, that the British sheet would be most eligible; and as to a south and north roof, rough plate on the south, and

sheet on the north; however, we have no experience of the rough plate.

As an encouragement to those about to venture on the Hamiltonian system, it may be observed, that Mr. H. has had it in operation for many years. At first, in a poor, low, contracted, and rough-looking house, which, without the noble pines it contained, would have been but a sorry affair. Such, however, was his success, that his employer empowered him to build a handsome new house to his own liking, and here the system may be seen duly carried out. We now give an extract, in concluding *this paper*, from Mr. H.'s letter now on the table: "The gardener of H. Marsland, Esq., of Woodbanks, is going by my instructions. He has three plants of the Montserrats (?) with three fruits each, and there is every probability of the nine fruits weighing thirty-three pounds." R. ERRINGTON.

(To be continued.)

YUCCAS.

In these days of plant-growing, for fame, for gold or silver medals, or for hard cash, such old plants as Adam's needle, and the like of it, that are thought beyond the art of the specimen grower, are left to nature, or rather are taken from her care, and then turned adrift to take care of themselves as best they may. *Yuccas* will grow or live in any kind of soil, if it is not too wet, and when one flowers any thing beyond the common run, it is reported in the periodicals as something strange, like the flowering of the American Aloe, as it is called, and no one turns his attention to the improvement of the race, or, if he does, he thinks there is little merit in saying much about it. Hence it is, that if you wish to flower a *Yucca*, and would learn the easiest and best way to go about it, you may look through all the authors, from Phillip Miller to the last number of *THE COTTAGE GARDENER*, and not be much the wiser. Indeed, I do not remember a single author who has given a full account of the propagation and cultivation of *Yuccas* as a class, except Mr. Gordon, of the Horticultural Society's Garden, at Turnham Green, and that was seven years ago (*Gardeners' Chronicle*, 1845, p. 384). Since that time, Mr. Gordon has so far improved on his own recorded practice, that his success surprised me the other day on looking over the garden. Like most other gardeners, I never dreamed that *Yuccas* are as susceptible of improvement, at the present day, as the Pine-apple plant was twenty years ago; but so it is, without any shadow of a doubt, and not only that, but it may be so managed as to become a regular competitor on the exhibition tables.

As far as I can make out, we have only one instance on record, in which a *Yucca* was exhibited in a pot for a prize, and that was in Fifeshire, in Scotland, some years ago. The flower-stem of this plant rose seven feet from the pot; the plant was exhibited in September, and was only struck from a cutting the March before. We know that some people run away with an idea that the *Yucca*, and the American Aloe, flower only once in a hundred years; others are as far wrong, who assert that a *Yucca* will flower regularly every year, after it once comes to a flowering age. The opinions about this age are also as far from the truth as the rest of the story. Some will tell you that five or seven years will bring it into a flowering state; others say ten years; whilst a third says fifteen, and a fourth goes as far as twenty. All this is in black and white, in my own library; but there is a *Yucca* in the next parish to me, Long Ditton, which did not flower for twenty-five years after being planted, and it might have been two or three years old at the time. It is now in bloom for the third time, and there were just five years between each time of flowering.

The truth is, however, that the flowering of *Yuccas* depends on soil and situation, rather than on certain or uncertain dates.

Yucca gloriosa is the one we hear most about, and this plant is a native of the sea-shore, in the southern states of North America, and although it lives with us in almost any soil or situation that is not absolutely wet, it prefers the sea-coast, a full southern aspect sheltered from all other points, the best friable loam, and a rock, or chalky bottom perfectly dry. In such situations in Devonshire, Cornwall, the Isle of Wight, and the South of Ireland, it blooms every year as well as it does in Virginia or South Carolina.

At its full age, it is not proof against those very severe winters we sometimes experience in this country. For instance, the great celebrated tree *Yuccas*, in the Oxford Botanic Garden, with stems five feet high, clear of leaves, and which Mr. Baxter, the no-less-celebrated curator, successfully transplanted, were cut down to the ground by the frost of the winter of 1837—38, but they sprang again from the roots, while plants of four or five kinds of them, not nearly so large or ripe, as we may say, stood out in Kilkenny without any protection whatever. It has been observed, that more *Yuccas* flowered with us in the hot summer of 1826 than in any one season before or since. In that year, a *Yucca gloriosa superba*, the best variety, with the purple on the back of the petals, flowered for the first time, after being twelve years planted, and two years when planted in a nursery at Windsor. The top of the flower-stem was twelve feet six inches from the ground; the flower-stem itself being upwards of nine feet; out of this stalk grew forty-seven side branches, eighteen inches and upwards in length, and each produced from twenty to thirty flowers, or probably 1,100 flowers in the whole. Who would not envy so noble a specimen of this much-neglected plant. "But stop a while"—another individual of the same species, whose girth, at fifteen inches from the ground, was 25½ inches, produced six flower-spikes at the same time, on which was counted in one day no less than 2,704 flowers. But the most splendid specimen of *Yucca* on record, under cultivation, is a plant, or rather tree, of the Aloe-leaved species, of which the Countess Dunraven sent a drawing to Mr. Loudon, from the gardens at Adare, in Ireland. This drawing is given in many of Loudon's works; in the *Vegetable Kingdom* of Dr. Lindley; and in other works here and on the continent. This *Yucca* was twenty-eight feet high; at ten feet from the ground the trunk girted seventeen inches, and at twenty feet it divided into "six massy branches, each terminating in a pyramid of flowers." Notwithstanding such instances, a *Yucca gloriosa* that is from three to five feet high in the stem and leaf, with a flower-stem of about equal dimension, would be a very fair specimen to pride oneself on, after a few years cultivation, on the principle advised by *THE COTTAGE GARDENER*.

It is very strange that no writer has sufficiently admired the *Yuccas* as fit plants to introduce into geometric flower-gardens, for which they are admirably suited, when reared with the sole view of that kind of furnishing; and no less so, that some of our great architects—Sir Charles Barry, for instance—have never thought of them as architectural plants, as one may say, instead of the great aloes which Sir Charles, at any rate, is so fond of for rearing up on pillars and corners in his elaborate designs. I could name more than one place in which Sir Charles Barry introduced, not only an aloe or two, but aloes in great numbers, as architectural ornaments, such aloes being cast in lead, and placed in stone, or composition vases, after being daubed over with a vile light-green colour, cockney fashion; and these aloes, too, anything but real imitations of the natural plant. Add to all this, a sharp north-easter, the thermometer

three parts down to zero, and a lot of gardeners sliding on the ice-clad lake, or carrying a cabbage on a long pole, looking over the hall, the castle, or the mansion, decorated in this pseudo style, and you have anything but a picture true to nature or to art.

Although the *Yuccas* have been cut down to the ground by some of our severest winters, they are yet sufficiently hardy to be allowable, in effigies, as accompaniments to architecture, without outraging our ideas of means to an end; at any rate, they are highly appropriate for planting in corners, angles, or other spare places in regularly laid-out gardens, as any one may now see, looking at the new plantation of *Yuccas* in the American garden of the Horticultural Society of London. There is not such another batch of *Yuccas* in the three kingdoms—that is, so fit for planting as ornaments to a flower-garden.

People far off in the country, who knew the old arrangement of this garden, will recollect a large mass of *Yuccas* which stood, for half an age, not far from the great and celebrated *Glycine*, where a short piece of wall projected from the long conservatory wall on which the *Glycine* is trained. All this is now altered: the cross wall is taken down, and the *Yuccas* are removed; so that the whole of the conservatory wall, from the cloak-room to near the council-room, can be seen at one glance—an immense improvement. Some of the *Yuccas* look as old as if they were the very plant from which Adam took his needle, and some of them had I know not how many heads. But now, in their new bed, they are all single-headed, and look as young and thrifty as Mr. Errington's pines which he struck from his best suckers last March, and much after the same style of growth, without any visible sign of a stem to any of them. Many of them promise to flower next year, and that in a manner as far superior to the usual run of *Yuccas*, as the present state of pine-growing is from what it was when Mr. Errington first went into Cheshire; and it is in this very style that they will soon be seen in our best flower-gardens all over the country. But it is sad news to us who are poor, and are members of this Society, to learn that they will not be able to supply us with a single *Yucca* from our own garden, at least, for the next four years, for this reason, that the whole stock has been divided to the last head and sucker for the new plantation, and that the young plants are in such a vigorous state of health, that one can hardly look for a sucker from any of them before the time specified. We must all trudge to the nurseries; meantime, I shall keep on hammering at the subject until every plant of *Yucca*, in every nursery in the kingdom, is made the most of, like those in the Society's garden; and who will venture to say there is nothing new under the sun when I describe the perfectly new way by which the old *Yuccas* in this collection have been renewed to the age of mere suckers?

The more usual way of increasing this family is from suckers which rise from the roots, and from divisions of the head that are branchy; these are slipped off in the spring, and some of the lower leaves being removed, and a few days allowed for the wounds to dry, the suckers are either planted out in the open ground, in some light soil, where they will root during the summer, or they are potted in a light compost, and then plunged in bottom-heat, where they will root much sooner. But when neither suckers nor side branches are produced, Miller, the only author on whom I can lay my hands, who has recommended the plan, directs the head to be cut off, taking a portion of the old stem with it, potting this, and applying bottom-heat to it, when it will soon root; "and this cutting off the heads will occasion the stems to put out suckers, which they seldom do without until they flower; so that by this method the plants may be obtained in plenty." This is the method which

Mr. Gordon adopted with the tops of all his old plants, after divesting them of all side branches. Suckers and offsets he formed into one lot, and all the tops into another, taking off long pieces of the old, dry stems along with single heads; but, instead of nursery rows, and potting for hotbeds, he removed the whole at once to his new plantation, and planted them in as novel a way as his success is complete. Indeed, I never saw anything answer better; formerly he recommended a hole for them, a foot deep and two feet across, to be filled with a good compost; then to plant a sucker, or a well-established plant in the middle, and to press the soil firmly round the stem; on this occasion, however, he tried a new experiment. After opening the holes, he made a compost of half clay and half cow-dung, and stuck in his plants so that the bottom leaves were just within the surface, and then he rammed the compost round the stems as hard as if he was laying the foundation for a pyramid; and if the plant was at all top-heavy, he put a stone on the top to steady it still firmer. The cow-dung kept the clay from drying too hard for the new roots to work through, while the clay was yet firmer than any loam could be for steadying the plants; and as soon as roots were made, there was a rich feast for them to begin with, and the plants now show that they took advantage of it.

I have often seen young pine-apple plants healthy enough to gladden the heart of any old gardener, but I never saw plants more healthy, or better-looking in their way, than these *Yuccas*.

And now, for THE COTTAGE GARDENER: just look round and see if you have a starving *Yucca* anywhere about the garden, with a crooked stem as hard and dry as a May-pole, and if it has ever flowered, the chances are that it has more than one division in the head; all the better; every division of the head will make a new plant. You must now trace where the head divides, and strip off the leaves below that point; then it will be easy enough to slip off every division but the one which seems the most central, this must be left to go with eighteen inches or more of the hard crooked stem to form your premier plant. Never think, for a moment, of taking up the roots, and of transplanting the whole as it is, for that would spoil the whole experiment; you cannot force blood through dry bones, or sap from the old roots up through a stem as dry as a cork; but get young fleshy roots from the very bottom of the leaves, and as far down the piece of stem as they like to come, the sap will flow vigorously, and the leaves will soon be as green as leeks, and as stiff as pokers; and if you plant them as above, and arrange them so as to be in pairs, no matter how far apart, there are no plants that will more stamp the character of a terrace garden, the front of a box terrace, or, indeed, any geometric figure.

At the end of next March will be the best time for all this; *Yucca gloriosa superba* the best plant to use—the one with the purple back to the white flowers, and *Yucca draconis*, or *recurva*, or *recurvifolia*, or *acuminata*, for it goes under all these names, is the next best. This kind turns back the leaves in the middle, looking as formidable as a dragon, which gives meaning to the second name; but *recurva* means that kind of turning in the leaves. The third best kind is *filamentosa*, and it has no stem, but it flowers very freely, and is easily known by the white threads or filaments which hang from the edges of the leaves. There are many more kinds, they say as many as thirty, but these are enough to begin with in a small way. If I had a long walk with grass on both sides, I would make an avenue of these *Yuccas*, planting them ten or twelve feet apart, and six feet from the walk; a more ambitious man, with a large stock of plants in the reserve garden, would try to have every other plant in bloom along both sides at once, and the other half the year following. D. BEATON.

THE GREENHOUSE.

I SHALL shortly advert to several plants, to meet the inquiries of several subscribers.

CANTUA DEPENDENS.

"I have a plant twelve months old; should I let it get quite dry in winter, or how manage it?" This plant may be treated, in many respects, as a fuchsia, but it will not stand so much *dryness* in winter, because its stems are much more slender, and less succulent. Even fuchsias, though rejoicing in a rest in winter, are frequently injured by being kept too dry at that period, especially when it is intended to preserve any part of the old stem. One of the finest plants I have seen of the *Cantua*, was, in my opinion, injured in a similar manner. It had been grown freely during summer in an intermediate house, and was beautifully branched all round from a central stem. It was then put in an airy place, in autumn, to ripen the shoots, and kept cool and dry in winter; but in spring and summer it only showed a few flowers from the strongest and terminal shoot. I think one of two courses should have been followed:—to have kept the plant slowly growing without a check, and waited for the sunny-days of spring and an airy position to get masses of bloom from the end of the shoots; or, what I should prefer, with a strong established plant, allow the wood to get ripened before autumn, give the plant a temperature of about 45° in winter, with no more water than would keep it just moving; then prune it back considerably in spring, place it in a warmer place, or the closest and warmest end of the same house; re-pot, if necessary, when the young shoots are one inch in length; shade, syringe, and encourage with suitable moisture, and, if possible, additional heat, and an open airy position, and the stiff, but luxuriant shoots will furnish you with its beautiful dependant fuchsia-like flowers. The plant will thus require similar management, but a little *more* care than a fuchsia.

Propagation.—The small side-shoots, formed after pruning back, when a little firm at their base, and from two inches in length, make the best cuttings. Take them off, if possible, close to the old stem, wounding it as little as may be; use a lancet-like knife for cutting clean across at the base; remove a few of the lower and small leaves, and then insert the cuttings in silver-sand, over sandy-peat, in a well-drained pot, cover (after watering) with a bell-glass and place any where where shade can be given, and a temperature secured a little higher than the parent-plant previously enjoyed.

Potting.—On getting a small tiny plant, you may continue giving successional pottings as the pot gets filled with roots; but after twelve or eighteen months growth, when the plant is pretty well established, one potting, as instanced above when growth was progressing, would, in every respect, be preferable.

Compost.—Sandy peat, a little turfy loam, and broken pots, for the first potting, increasing the loam in subsequent pottings. When the plant gets established, let the loam be nearly one-half, with a portion of charcoal, broken pots, and dried nodules of cow-dug.

Watering.—Give liberally when the plant is growing freely; lessen as autumn approaches; just see that the soil is not dry in winter; apply weak liquid-manure when the first flower-buds peep, and let the water be aerated, and always as warm, rather warmer, than the temperature in which the plant is growing.

Temperature.—40° to 45° in winter, 50° to 55° in spring, 60° in summer, 50° to 55° in autumn, with from 10° to 15° rise for sunshine, during which, in spring especially, the syringe may be used.

Insects.—Keep free, is the grand thing; fumigate for fly, use sulphur for the spider, but *carefully*, as the plant is very sensitive to brimstone.

DEUTZIA GRACILIS.

It is complained that "this will not grow." It is, however, one of the prettiest things lately introduced; but I suspect it always will be a plant of *slow*, as well as slender growth. A correspondent may expect his plant, four inches high, to produce its pretty white flowers next March, or the beginning of April, if he keeps it all the winter in a common greenhouse. After satisfying himself with seeing the first flower, I would recommend every flower-bud to be removed, and the points of the shoots to be stopped, and the plant placed in an airy, warm corner, to encourage growth. Not that the plant *absolutely* requires heat, for I believe, ultimately it will be found that it is as hardy, or nearly so, as *D. scabra*; while that, again, in many places, has proved itself as hardy as the Philadelphus, or Mock Orange. So long as *D. gracilis* is rather scarce, and in a small state, it would be folly to place it in a shrubbery, or even at the foot of a wall, though, no doubt, ere long, it will be placed in both positions. At present, and especially when in a small state, a dry, cold frame, or pit, or a common greenhouse, will be the most suitable winter quarters. It produces its flowers one season on the slender, well-ripened shoots produced in the preceding; this must be kept in mind when growing and pruning. It grows so slowly, that little pruning, farther than nipping the points of shoots and thinning the young ones, will be required. If these young shoots are well ripened in autumn, extra heat will bring the flowers out any time in winter, especially after Christmas.

Compost.—Equal parts of sandy peat and loam, when young, increasing the loam, and adding leaf-mould and cow-dung as the plant gets older and larger.

Watering.—Give liberally when growing and flowering; lessen the quantity in autumn, and just see that the soil is moistish in winter. In bright days, at the latter period, it will be better to lessen evaporation, by a dusting over the top with the syringe, in preference to soaking the roots. On this account, many small plants, in little pots, that require *rest* in winter, are best kept when plunged *in*, and the pots surfaced with moss. The roots are thus kept easily in an equal state, neither wet nor dry.

Propagation.—Cuttings of ripened one-year-old wood, taken off in autumn, and inserted in sandy soil, under a bell-glass or hand-light, in a cold-pit, the glass, however, not being pressed close down; or small side-shoots in spring, when 1½ inch long, inserted under a bell-glass, and placed in a temperature a few degrees higher than that of the plant from which the cuttings were taken.

DEUTZIA SCABRA.

This, though an old plant, is still a most interesting one, whether used for the greenhouse or the open shrubbery. It is easily propagated by young, stiff, side-shoots, under a hand-light, in a shady place, in June; but easier still, by inserting ripened young shoots in a shady, sandy border in autumn, just as you would do a currant cutting. If grown in pots, and taken into the greenhouse, it will bloom in the end of March and in April. If wanted earlier, it will stand a gentle forcing. Few things are more lovely than its shoots, from two to four feet in length, covered with its beautiful snow-white flowers. When done flowering, and the young shoots are growing freely from the bottom, all the old shoots should be cut away, and the young ones thinned to the required number; five or seven being a good number for a large pot. When growing, the plant will relish manure waterings. Ripening the young shoots is the great thing to ensure fine flowering. Treat it in every respect as you would a favourite raspberry-bush. A good loamy soil suits it.

WEIGELA ROSEA.

This, when treated as a greenhouse plant, may be managed almost in every respect as the above. It seems quite as hardy as any shrubby Philadelphus, or Honey Suckle. I never succeeded so well with it as with the *Deutzia*, though certainly it is worth a little attention for decorating a house in the spring months. It blooms chiefly, not on last year's shoots, but on those of the current season, coming from well-ripened buds on last season's growth. In pruning for blooming, therefore, we must take the *vine*, and the *rose*, and not the raspberry, as our example. The bush character is thus easily produced. Both the *Weigela* and the *Deutzia* may now be lifted carefully, and potted, and if the pot is plunged in any material containing a little heat, while the top of the plant is exposed, the rooting process will be encouraged, and the plants may afterwards be set in the greenhouse, or forced in spring.

ESCALLONIA MACRANTHA.

This, "with a stout stem, eighteen inches high, and nice side branches, four inches long," may be expected to yield you a few of its pretty flowers next season. If, however, a fine specimen is your object, I would not be too anxious for many flowers. Keep it in a moderate greenhouse during winter, and place it in an airy cold pit out-of-doors in summer. Use rather more peat than loam at first, increasing the loam by degrees. The plant, when two or three feet in height, if a young stock has been secured, might be ventured against a conservative wall. Stubby young shoots will strike under a hand-light in summer. Younger ones will strike more quickly at an earlier period; but they must be inserted in sand, over sandy-peat, covered with a bell-glass, and kept in a frame or pit.

CEANOTHUS RIGIDUS.

This, "nine inches high," can hardly be expected to bloom next season, nor would it be desirable, though the species or variety will bloom when in a small state. This and *dentatus*, from their stiff habits, are amongst the best of the semideciduous kinds for greenhouse decoration. Like others, they chiefly bloom on young shoots of the current season's growth, proceeding from well ripened buds of the former year. The plant should, therefore, be kept moving, and no more, during the winter. The young shoots should be cut back to the lowest bud in spring, or nearly so, and this will throw more strength into the young shoots. A warm corner in the greenhouse will be the best place for them until May, then, a cold pit in summer, and full exposure in autumn, defending the plants at the close from heavy rains and incipient frosts. Cut off the greenest part of the shoots in winter; keep the plants cool then, and neither wet nor dry. The increase of heat and sun-light in spring, and the necessary increase of moisture, will give an impulse to the vegetative powers, and young shoots will be freely produced; which, if the plant is old enough, and the wood matured last season, will yield you charming blue flowers in summer. These young shoots, taken off close to the stem when from two to three inches in length, make nice cuttings when inserted under a bell-glass, or hand-light, in sandy loam, with sand on the surface. The pots for plants must be well drained, and then loam, with a little sand and peat will grow them well. Though ornamental for a cool greenhouse, a conservative wall, protected with a glass case, would be the best position for this and the greater part of the species that did not require a tropical temperature.

MITRARIA COCCINEA.

This has as pretty a scarlet tube as any Gesnerwort of them all; but, unlike the most of the group, instead of soft succulent stems and large leaves, it is a compact

little shrub, with small neat foliage. The first time I saw it, visions of flower-beds of it flitted before me. These I have not yet seen realised, and, perhaps, the flower droops rather too much for the purpose; but, as a hardy greenhouse plant it will be of great use in spring and early summer. I am not aware that it has yet been tried out of doors. It will grow nicely in rough peat and loam, and, after it is some size, will stand in a cold pit, or out-of-doors in summer. Fibry peat and sandy loam, rough in proportion to the size of the shift given, will grow it well.

Little pruning, farther than nipping the point of a strong shoot, to produce uniformity of growth, will be required. The pots should be well drained, and about a seventh part of the compost should consist of broken pots and clean charcoal. With good drainage, waterings will be required freely in the growing and blooming season, decreasing as the end of autumn approaches, and giving it but seldom in winter; the temperature in the latter period, with air, at all suitable times during the day, may range from 38° to 45°, allowing a rise for sunshine. I have no doubt the plant would do well near a conservative wall, especially if furnished with a glass-case. Stubby, half-ripened shoots will strike quickest under a bell-glass, when having a slight rise of temperature, shade, &c. Older cuttings will require less trouble, but more time.

R. FISH.

CONIFERÆ.

(Continued from page 398.)

CUNNINGHAMIA SINENSIS (Chinese Cunninghamia, or Broad-leaved Chinese Fir).—Named in honour of its discoverer, Mr. James Cunningham, by L. C. Richards, a celebrated French botanist. It was originally named, by Mr. Salisbury, *Belis jaculifolia*, and by Mr. Lambert, author of a Monograph on Pines, *Pinus lanceolata*. It is the only species yet discovered. Very ornamental, but too tender for the northern parts of England. In Devonshire and Cornwall, and even in Gloucestershire, it has as yet withstood the severity of the climate. No doubt, in many parts of Ireland it would thrive well. It is a very ornamental tree, rising to the height of fifty feet in China and Japan. It is as yet very rare.

CYPRUSSUS (Cypress).—This genus contains an assemblage of trees and shrubs highly valued for their beauty, and well adapted to ornament the pleasure-ground, or form beautiful objects in the Pinetum. Their style of growth, generally upright, and densely clothed with branches and foliage of a pleasing dark green, in some instances, and light green in others, renders them exceedingly beautiful objects. Many species were known and highly valued by the ancients. Pliny mentions a Cypress at Rome which fell in the time when Nero was Emperor, and was judged to be as old as Rome itself. Five hundred years ago a Cypress was planted on the grave of the renowned poet Hafiz, and is yet alive, a living monument to the memory of the poet. There is a remarkable Cypress at Lomna, in Italy, which has attained the height of one hundred and twenty feet, and is more than twenty feet in circumference at the base of the stem. The use of the Cypress as a memento of the departed in cemeteries is well known; even to this day it is used for that purpose in various parts of the Old World: the far-famed Funereal Cypress was seen by Lord Macartney in China, in the "Valley of Tombs." All these particulars recommend the plants of this genus to the peculiar notice of the antiquarian, the scholar, and the man of taste, as well as to the owner of pleasure-grounds, the planter, and the nurseryman. Even the name is interesting, being said to be derived from *Cyparissus*, a handsome youth of the Island of Ceos, who was, according to heathen mythology, changed into

a Cypress; though some authors think the name is derived from the Isle of Cyprus, where one species abounds.

C. CORNEYANA (Mr. Corney's Cypress).—China. A very handsome species, of an elegant drooping habit, not much known, but well adapted to ornament either a small or large garden. Very scarce.

C. FASTIGIATA of Decandolle (Common Cypress).—This species is extensively spread over the South of Europe, Greece, Turkey, and Asia Minor. It is the Cypress of the ancients. It is the species so often referred to by Homer, Virgil, Ovid, and Lucretius, in their poems. The wood is remarkable for its durability. For avenues, it rivals the Junipers and the Arbor Vitæ, associating admirably with the balustrades of a terrace-garden. It is useful, also, to break the outline formed by round-headed low trees. It is perfectly hardy, cheap, and plentiful in the nurseries. There are two varieties, one named *Thujaefolia*, from resembling an Arbor Vitæ, and *Variiegata*, from its foliage being variegated.

C. FUNEBRIS (Funereal Cypress).—This species has been already referred to, as having been seen by Lord Macartney, and it was noticed also by Sir G. Staunton; but we are indebted to Mr. Fortune for introducing it to this country. He published an account of it in the Horticultural Society's Journal, where he describes it as "a noble-looking fir-tree, about sixty feet high, having a stem as straight as the Norfolk Island pine, and branches drooping like the weeping willow. The branches grew at first horizontally with the main stem, then described a graceful curve upwards, and drooped again at the points. From these main branches, others long and slender hung down towards the ground, and gave the whole tree a weeping and graceful form. The form of the tree was very symmetrical, and reminded me of some of those large and gorgeous chandeliers which one sees in public halls in Europe. It has a most beautiful and striking effect upon the Chinese landscape." Perhaps the largest stock in Europe of this favourite Chinese tree is in the nursery of Messrs. Standish and Noble, at Bagshot. We saw them on a visit there already alluded to in writing on the *Cryptomeria japonica*; but the largest of them has not as yet assumed the drooping form. Hitherto it has proved perfectly hardy, and is so plentiful, that nice plants, nine inches high, may be had for 2s 6d, or even less, if a quantity is taken.

C. GOWENIANA (Mr. Gowen's Cypress).—Named in compliment to Mr. Robert Gowen, Treasurer to the London Horticultural Society. This is said to be a low shrub or tree, of some ten feet or fifteen feet high in its native country, California; but, from what we have seen of its quick growth, it must in this country eventually attain a much higher altitude. An interesting, upright-growing species, with very bright green foliage.

C. HORIZONTALIS (Spreading Cypress).—A native of the South of Europe, but perfectly hardy in Britain. Described by Du Hamel as a variety of the Upright Cypress, with the branches spreading out at right angles from the stem. It is like the species in every other respect, and forms a handsome tree forty feet high.

C. KNIGHTIANA (Mr. Knight's Cypress).—The origin of this beautiful species is unknown. From the plants that we have seen of it, it appears sufficiently distinct; it is allied to *C. torulosa*, and, like that species, is rather tender in the northern parts of Britain. T. APPLEBY.

(To be continued.)

ROSES ARRANGED ACCORDING TO THEIR COLOUR.

A CORRESPONDENT, who signs himself "A Derbyshire Subscriber," writes for information about selecting

Roses, so as to have only such as are distinct in colour. He says, "The great objection to these flowers is their sameness of colour. I want to get all the really and strikingly distinct shades, from the darkest crimson to pure white, and thence again to bright yellow." Now, we think this idea a good and useful one, and, as our correspondent suggests, one that would be useful to others, as well as himself, that are about to purchase roses. We, therefore, shall draw up a selection of Roses possessing the property of colour in high perfection. Suggestions of this nature from our readers are always useful; they lead the writers for THE COTTAGE GARDENER to enter upon such subjects as our subscribers wish for information upon, and, by that means, diffuse the knowledge required. Correspondents, therefore, wanting information suitable to their particular locality, need not fear writing for it; but they ought always to send full particulars as to locality, soil, and subsoil—whether the soil is high or low, whether well-drained, and any other particular they may think necessary to be known, in order that the answer may contain the fullest instruction in every point.

To return to our subject of selecting Roses, our correspondent wishes to combine roses for the open border and roses for a wall, or trellis, in the selection. This is somewhat difficult, as there are not so many climbing roses of distinct colours as there are in those that are not climbers. The list may appear somewhat long, but our correspondent, or others, may easily shorten it in giving their orders. The varieties are all good, distinct, and will, we believe, come true to the colours indicated.

T. APPLEBY.

COLOUR: DARK CRIMSON.

SUMMER ROSES FLOWERING IN MAY, JUNE, AND JULY.

FOR THE OPEN BORDER.

Provence.
Sylvain
Moss.
Celina
Countess de Noé
Cranoisie foncée
Du Luxembourg
Etna
Lanci
Damask.
Reine de France
Prince Regent
Hybrid Provence.
Garibaldi
Hybrid Chinese.
Aurora
Chénédole
Honneur de Montmorency
Marie de Champlouis
Hybrid Bourbon.
Paul Ricaut
Vulcan
Gallica.
Jules Bagot
La Amethyst
Ohl

FOR WALKS AND TRELLISES,
OR PILLARS.

Hybrid Chinese.
Chénédole
Brennus
Descartes
Fulgens
Paul Ricaut
Hybrid Bourbon.
Sylvain
Anadis, or Crimson Bour-
sault
Ayrshire Queen
Russelliana

AUTUMNAL ROSES FLOWERING FROM JULY TO NOVEMBER.

Perpetual Moss.
Herman Kegel
Damask Perpetual.
La Capricieuse
Thiers
Hybrid Perpetual.
Apollo
Baronne Hallez
Charles Bossiero
Bossuet
Grand Capitaine

Hybrid Perpetual.
Gloire de Rosamene

FOR THE OPEN BORDER.

Bourbon Roses.
Comice de Seine et Marne
Deuil de Duc d'Orleans
Dupetit Thouars
Paul Joseph
Souchet
Chinese, or Bengal Roses.
Assuerus
Beau Carmiri
Citoyen des deux Mondes
Cramoisie Superieur
Fabvier

FOR WALKS AND TRELLISES,
OR PILLARS.

Chinese.
Cramoisie Superieur
Fabvier
Marjorlin du Luxembourg
Noisette.
Eclair de Jupiter
Fellenberg

FOR THE OPEN BORDER.

Hybrid Perpetual.
Beranger (New)
Cassimir Delavigne
Comte de Paris
Edward Jesse
Lane
Madame Joley
William Jesse
Bourbon.
Aurore du Guide
Charles Souchet
Desemet
Hennequin

FOR WALKS AND TRELLISES,
OR PILLARS.

Hybrid Perpetual.
General Changarnier

Bourbon.
Julie de Fontanelle
Louis Philip D'Angiers

COLOUR: SCARLET OR CARMINE.

SUMMER ROSES FLOWERING IN MAY, JUNE, AND JULY.

Moss.
Emperor
Globuleuse
Gallica.
Eblouissante de Laqueue
Nouvelle Provence
Pashet
Rouge Eblouissante
Hybrid Chinese.
Beauty of Billiard
Dombroskii
Gloire de Couline
Parigot
Virginie Zechler

Gallica.
Colonel Coombes
Feu Brillante

Hybrid Chinese.
Mareschal Soult

AUTUMNAL ROSES FLOWERING FROM JULY TO NOVEMBER.

Perpetual Moss.
Perpetuelle Mauget
Damask Perpetual.
Elise Masson
Hybrid Perpetual.
Doctor Marx
Etendard de Marengo
Lady Francis de Waldegrave
Lady Alice Peel
Pius the Ninth
Robin Hood
Comte d'Eu
Geant des Batailles
Louise Fabvier
Bourbon.
Bouquet de Flore
Dumont de Courcet
Henri Clay
Henri le Coq
Justine
Chinese.
Carmin d'Yebles
Prince Charles

Hybrid Perpetual.
Louis Buonaparte
Robert Burns
Comte Bobrinsky

COLOUR: PURPLE CRIMSON.

SUMMER ROSES FLOWERING FROM MAY TO JULY.

Moss.
L'Obscurité
Damask.
Bouvet
Gallica.
Boule de Nanteuil
Cambronne
General Damremont
Tricolor Superb
Great Western
Legouvé
William Jesse

Damask.
Duke of Cambridge
Gallica.
Heureuse Surprise
Frederic the Second
General Jacquemont
Lady Hamilton
Legouvé
Climbing Roses.
Elegans

AUTUMNAL ROSES FLOWERING FROM JULY TO NOVEMBER.

Perpetual Moss.
General Druot
Damask Perpetual.
Mogador

COLOUR: DEEP ROSE.

SUMMER ROSES FLOWERING FROM MAY TO JULY.

Provence.
Adrienne de Cardoville
Moss.
Charlotte de Sor
Damask
Crested
Foncée
Prolifere
Damask.
Sextus Popinius
Gallica.
Duchess of Buccleugh
Napoleon
William Tell
Hybrid Provence.
Adeline
La Ville de Londres
Hybrid Chinese.
Adèle Bear
Belle Marie
Coupe d'Amour
General Allard
Henri Barbet
La Superbe
Tippoo Saib

Climbing Roses.
Gracilis
Madame Plantier
Superba

AUTUMNAL ROSES FLOWERING FROM JULY TO NOVEMBER.

Damask Perpetual.
Cælestina
Hybrid Perpetual.
Augustine Mouchelet
Aubernon
Comte d'Egmont
Duchess de Galliera
Earl Talbot
Montaigne
Rivers
Bourbon.
Augustine Leleur
George Cuvier
Chinese.
Augustine Hersent
Reine de Lombardie
Tea Scented.
Belle Marguerite
Madame Goubalt

Hybrid Chinese.
Henri Barbet
Jenny

Hybrid Perpetual.
Montaigne
Mrs. Elliott
Prudence Reser

COLOUR: LIGHT ROSE.

SUMMER ROSES FLOWERING FROM MAY TO JULY.

Provence.
Cristata
Rachel
Moss.
Blush
Crested
De Metz
Jean Bodin
Princess Royale

FOR THE OPEN BORDER.

Damask.
La Ville de Bruxelles
Leda
Alba.
Lucrece
Vicomte de Schrymaker
Gallica.
Celestine
Cynthia
La Jeune Reine
William the Fourth
Hybrid Provence.
Adèle Sanger
Roi de Pays
Hybrid Chinese.
Comte Boubert
Comte d'Hebe
Leopold de Bœuffrémont
Paul Perras
Prince Albert

AUTUMNAL ROSES FLOWERING FROM JULY TO NOVEMBER.

Damask Perpetual.
Josephine Antoinette
Hybrid Perpetual.
Baronne Prevost
Clementine Seringe
Duchess of Sutherland
Madame Pepin
Queen Victoria (New)
Reine des Fleurs
Titus Livius
William Griffiths
Pompone
Viscountess de Belleval
Bourbon.
Apolline
Armosa
Coupe de Hebe
Theresa Margat
Souvenir de Malmaison
Noisette.
Euphrosyne
Chinese.
Mrs. Bosanquet
Virginile
Tea Scented.
Adam
Caroline
Lyonnais
Nina

COLOUR: WHITE.

SUMMER ROSES FLOWERING FROM MAY TO JULY.

Provence.
Unique, or White
White Burgundy
Princess Lamballe
Moss.
Unique
White Bath
Damask.
Blanchette
Madame Hardy
Pulcherie
Hybrid Provence.
Blanchefleur
Blandine
La Vestale

AUTUMNAL ROSES FLOWERING FROM JULY TO NOVEMBER.

Macartney Rose.
Maria Leonida
Moss.
Perpetual White
Damask Perpetual.
Celine Dubois

FOR WALKS AND TRELLISES,
OR PILLARS.

Climbing Roses.
Blush Boursault
Rosea plena Ayrshire

Hybrid Chinese.
Leopold de Bauffrémont

Hybrid Perpetual.
Duchess de Montpensier
Lady Sefton
Madame Trudeaux
Reine Mathilde
Titus Livius
Comtesse de Rambuteau

Bourbon.
De Lamartine
Madame Desprez

Noisette.
Triomphe de la Ducherie
Viscountess d'Avesne

FOR WALKS AND TRELLISES,
OR PILLARS.

Hybrid Chinese.
Madame Plantier
Hybrid Perpetual.
Pauline Buonaparte
Leonide Leroy
Noisette.
Miss Clegg
Pumila alba
Chinese.
Alba
Camellia blanc
Tea Scented.
Clara Sylvain
Julie Mansais
Strombio

COLOUR: CREAMY WHITE.

SUMMER ROSES FLOWERING FROM MAY TO JULY.

Damask.
Madame Soëtman
Alba.
Madame Legras
Hybrid Provence.
Globe White Hip
Pauline Garcia
Double White Musk
Princess de Nassau
Noisette.
Caroline Marnieuse
Tea Scented.
Archduchess Therese
Belle Allamande
Bride of Abydos
Niphotos
Madame Brady
Romain
Taglioni

Climbing Roses.
Countess of Lieven
Queen of the Belgians
Laura Davoust

Noisette.
Caroline Marnieuse
Tea Scented.
Josephine Malton

COLOUR: FAWN, OR BUFF.

Bourbon.
Queen
Noisette.
Ophirie
Tea Scented.
Abricoté
Don Carlos
Jaune Abricoté
Moiret
Mondor
Perfection
Semele

Noisette.
Jaune Desprez
Tea Scented.
Marie de Medicis
Madame Plantier
Moiret
Safrano

COLOUR: YELLOW AND SULPHUR.

SUMMER ROSES FLOWERING FROM MAY TO JULY.

Austrian Rosea lutea
Yellow
Harrisonii
Persian Yellow
Rosa Sulphurea (Double
Yellow)
Noisette.
Clara Wendall
Cleopatra
Le Pactole
Mrs. Siddons
Simolor
Jaune (of Smith)
Tea Scented.
Devoniensis
Eliza Sauvage
Princess Adelaide
Viscountess de Cazes

Yellow Austrian
Persian Yellow
Rosa Banksia lutea, or Yellow

Noisette.
Clara Wendall
Solfaterre

"TAKING A LOOK ROUND."

THIS homely phrase is often pregnant with important events. A look round, "with the eyes open," frequently points out what ought to be done without delay; at the same time, a scrutinizing glance at the progress, or otherwise, which certain crops are making, recalls to mind what was done to that crop at the proper time; and either proves the justness or the fallacy of the treatment it is undergoing. "A look round," likewise, discloses many things it would be better to get rid of. If a survey takes place after a period of showery weather, weeds will be found in places expected to be clean, almost in number and luxuriance to dispute with the legitimate crop their right to a share of mother earth. "A look round," at this season, will also be accompanied with the inward expressions of "This job must be done"—"These *Carrots* must be taken up"—"These *Tomatoes* must have the sun"—"These *Cabbage-plants* are stifling each other in the beds, and none planted out yet; I will have that done to-morrow"—"These *autumn-bearing Raspberries* shall not dangle on the ground, and get themselves all dirt in that way, I will see and have them staked up." These, and a thousand other duties suggest themselves at every step when a general survey takes place; or, if we place the case on a higher standing, and allow that the skill and strength of the gardening staff has done all the above at the most fitting time, and that, with a shake of the head, the old garden labourer tauntingly invites inspection of everything in detail, still the eye of the critic, strengthened by the inquiries he makes, enables him to see some things that he thinks may be improved another season by adopting another course, which he explains.

It is thereby seen that "a look round" may be turned to account even in the best kept garden establishments. Now the amateur, who has only a few rods of ground, may also derive some interest, if not knowledge, in this systematic survey; we do not ask him to take stock in a mercantile form, but we ask him to reflect what small, insignificant plants those *Brussels sprouts* were when the peas, which over-topped them, were removed in August, and see how they have progressed since; if he has treated them with liquid-manure, he will, doubtless, be giving that enriching food the credit for their advance; but there is another agent as well, remember; August and September treated us to more rain than is usual for these months, hence the growth of this and similar productions. "A look round" will also display, that if *Early Horn Carrots* have not been removed from the earth some little time, they will now be surrounded by a white beard of new rootlets, indicative of a second growth, and certainly inimical to the root's keeping well. "A look round" will also tell him, that in spite of what great writers say about earthing-up *Celery* by wholesale, he must not lose the chance of the first fine day to do his, if it require ever so little; and, subsequently, the duty becomes still more imperative, as the days will not all be fine after this, and the growing season, which is synonymous with the blanching season, is fast drawing to a close; these, and many other necessary jobs, will suggest themselves, leaving the operator the discretionary power which one to do first; this, of course, must be regulated by circumstances, and the urgency of the individual objects. Suiting the work to the weather, is a golden maxim never to be lost sight of in gardening matters. The fine dry days, so plentiful at Midsummer, cannot be repeated now; consequently, the housing of root-crops, earthing of *celery*, and other needful duties, must have the first attention on such occasions, while a dull day will do to prick out *Cabbage Plants*, prepare ground for the principal crop, (the earliest one we suppose to have been planted some time ago). Beds, with some mode of applying a pro-

tecting article, may be prepared for *Cauliflowers*, which will speedily want planting out in their proper quarters, while *Dwarf French Beans* and *Scarlet Runners* must have mats, or something that way, thrown over them on frosty nights, which are likely now to follow bright days, with a north wind. To these duties may be added that universal one of having an eye to order, cleanliness, and good keeping, which in a garden, even at this time of the year, is not without its merits; still, by-and-by, the removal of bulky things, as *scarlet-runners*, *peas*, &c., and the ground dug after the leaves have fallen, will give the whole that more pleasing appearance which it is difficult to obtain while leaves are falling, and other things (though still useful) present a decaying aspect. One of the principal ornaments of a garden at this untoward season are sound *walks*; these, whatever may be the condition of the adjoining ground, ought always to be good, and at this time of the year their utility is more manifest, when access to the turf, &c. is denied by the damp grass to those for whose enjoyments all that is ornamental in a garden was introduced. Next to walks, are the *edgings*; these, if of box, may also be in nice trim at this season; if they were cut, as we advised, in the showery weather of June, they will have grown sufficiently to show a fresh growth, and yet not so much as to become unsightly large or jagged. Many other little things may be seen to in the way of giving a tidy appearance to the whole, and we can point out no better mode of the amateur finding out what wants doing, than just taking "a look round." J. ROBSON.

THE FORSAKEN HERITAGE.

By the Authoress of "*My Flowers*," &c.

My readers may remember that, some months ago, I described the effects of a thunder-storm as having smitten a tree—an old ash-pollard—and spared the cottage which stood almost by its side. That little cottage was the dwelling of a young widow and her four children, who had lost their earthly prop and stay some years ago. I am now going to tell the story of this young widow, for the benefit of others, who may, like her, be left alone on earth, with only the rich inheritance of God's promise.

Mary Anderson's husband had been a bargeman, and had settled in the village in consequence. His wife belonged to another county; she had no friends in her new parish, but they were steady, respectable young people, very quiet, and very clean; and when poor Anderson began to sink into decline many were kind and helpful to them. After his early death the poor young widow remained still in her little bit of a cottage. It looked away from the village over a sweet, sunny scene; it had a very small garden before the door, and a rough shed at the gable end. This, with a small kitchen, and a yet smaller bedroom, was the home of the widow and her orphan family.

Nothing could be cleaner or neater than Mary and her children. She was always so tidily dressed, without a shred of finery, and her shoes and stockings were so particularly clean and well made, that it was impossible not to notice her. She was never down-at-heel, like many of her neighbours, which gives such a wretched, slatternly look; and she was never seen in torn or draggled clothes, or standing gossiping about. Her two boys went to work, the little girls to school, and the mother was always seated in-doors, busy with her needle, alone, until the evening, when her little ones were also quietly at work by her side. The cottage was, indeed, the picture of what a widow's home should be.

There is a heritage for the widow and the fatherless, signed, sealed, and delivered into their hands, when the grave closes upon him who toiled and fed them. "Leave thy fatherless children, I will preserve them alive, and let thy widows trust in me."

Mary Anderson and her children were preserved alive. She had always work and food; friends were raised up, who sent them clothes; and neater, cleaner children could not

be seen in the parish. One of her boys gave her trouble, but, after leaving one or two farmers in disgrace, he at last got a place where his elder brother worked, and grew more steady and well behaved.

Mary was a kind creature among her neighbours. She would often get up in the night to help her poor bed-ridden neighbour, Betty Lamb. She would nurse the sick, and assist in the houses of her richer friends, when she could be spared from her own duties. She was able, also, to talk well on religious subjects. She knew the truth, and she *seemed* also to know the promise; but what we know we do not always feel; and it is one thing to "speak with tongues," and another to experience the power of the Spirit in our hearts.

A rumour at last spread by degrees through the village that Mary Anderson was going to marry again. No one at first believed it, but a man, who was himself a widower with a family, was seen very often digging in her garden, while Mary stood with her work beside him; and it did certainly look rather like a change, people began to think. Mary flatly denied the fact. She declared to her neighbours she had no thoughts whatever of marrying again; and when spoken to by a lady on the subject, she said quietly, but with her eyes cast down, "I don't know anything about it myself, ma'am."

That Mary was uttering falsehoods at last became evident to all. She became the wife of Sam Spicer, quitted her own little cottage, and entered upon her new home and duties, which lay at the other extremity of the parish. Mary had a right to marry again if she chose—there was no human reason why she should not; but it was plain that she condemned herself for doing so, by flatly denying the fact. Oh! nothing *can* prosper that is entered upon with a lie! God will not, He *cannot* bless it; and without His blessing—nay, with the curse upon "all liars" resting upon us—how can we reasonably expect even common good to arise from our undertaking?

Mary Spicer forgot the *promise*, or, at any rate, she gave it up with all its rich abundance, when she cast off her "first faith," and became the wife of a violent, savage-hearted man. No doubt she thought him what he professed to be, as *we* generally do upon these occasions, but her ground for so thinking was sand. He talked well, and deceived her. Let woman *watch the life*, and not listen to the words of the man who seeks her hand; let her be as "the deaf adder" to his voice, and open wide the eyes of her understanding to his actions. Mary Anderson closed her eyes and listened; and upon Mary Spicer's brow was stamped in deep characters, "Ichabod."

When the promise was cast aside, Mary soon felt the difference. She was shut up at a distance with her new partner for life; but the sad truth was soon made known and blazed abroad. Her poor little girls came among their old friends in the village with melancholy tales of all their misery; their backs and arms were black with blows; and they were glad to get out of the house and wander about any where, and any how. The sons were as miserable as the daughters; they idled about, rather than go to such a home; and instead of being clean, and well cared-for in their dress, they could not get their clothes properly washed or mended. Mary is seen now and then stealing through the village, downcast and dispirited. Her neat, cheerful look is gone, and she turns away as fast as she can from the gaze of her former acquaintance. How she must mourn in heart as she passes the grave of her first husband, and the cottage where the promise rested, and gave her so many blessings! How she must weep as she reads the title-deed that God has given to the widow, and that she threw madly away! She had *tried* the deed, and found it "faithful and true," so that her sorrow and self-reproach must, indeed, be almost too great to bear. Her violent husband treats her as cruelly as he treats her children; they share the same fate; but the bitterest pang to the mother's heart must be the stroke that falls upon her helpless and unoffending orphans.

Let the fate of Mary Spicer ring in the ears of all in her circumstances. Let it be a powerful warning to them not to cast off their "first faith," but to hold fast to the promise, and fear not that it will ever fail. While Mary sat quietly in her cottage, with her children round her, all went well

with her; the hand that rules the world, and that guides the bolt of heaven, can cover the heads of those that trust in Him, and shield them from every danger. Has He not said Himself, "Leave thy fatherless children, I will preserve them alive, and let thy widows trust in me?"

In my next paper, I shall sketch the life of one who dwells in the same village with Mary Spicer, and who is "a widow indeed."

BRITISH EATABLE FUNGI.

IN treating on these, I shall first speak of them collectively, and, secondly, confine myself exclusively to those indigenous to our British isles. Fungi are the most nutritious of all vegetables, and the nearest approach to animal food; some, if moderately used, are most nourishing in their raw state, as they lose their good qualities by culinary preparation; and those who have lived entirely upon them in their raw state for some time, with bread and water, state that they have experienced rather an increase of strength than otherwise. When eaten in this state, however, those should be chosen which have a solid flesh, and an agreeable smell and taste, as *Agaricus campestris* (Common Mushroom), *Agaricus procerus* (Tall Agaric), and *Tuber cibarium* (Truffle), &c.

I have little doubt that the very dread of the term Toadstools, and the unsightly appearance that some assume when growing in damp, gloomy, and unhealthy places, to those who do not appreciate their veiled beauties, together with the idea that the venom of serpents and toads renders fungi poisonous, and that, with the exception of the common mushroom, they are all injurious, has caused, through prejudice, which is too prevalent in this land, that valuable and most extensive order of plants to be despised and rejected as an article of food. A gentleman, who has travelled nearly all over the continent, informs me, that fungi appear in most of the markets, and are abundantly eaten, and that he never saw in the public journals, or otherwise heard of a case of poisoning from them. In Russia, Poland, and throughout the greater part of Europe, they form delicacies amongst the rich, and a regular article of diet to the poor people, whole tribes being frequently nearly wholly supported by collecting them; for, in addition to the immense amount of food they supply in their fresh state, they are abundantly preserved by drying, or soaking in oil, vinegar, or brine, and form a valuable article of commerce, from the products of which the poor man is enabled to purchase other necessaries, which he otherwise would be deprived of. To such an extent was the sale of fungi carried on in Italy, that in 1837 it was deemed necessary to fix a definite time and place in the public markets for the sale of fungi exclusively, and to appoint an inspector, who should examine the baskets brought into the city by the peasants previously to their sale. In most uncivilized countries they have been used as an article of diet by the natives, and in Australia, *Militaria Australis* is a fungus known as "native bread."

With respect to the cultivation of esculent fungi, little has been done in Britain, with the exception of the *Agaricus campestris* (Mushroom), which it is well known is cultivated by good gardeners with as much success as other vegetables, and it is extensively cultivated in the ancient quarries which run under part of the city of Paris. The *Agaricus campestris* is native to the whole of Europe, part of Asia, Africa, and America—reaching as far north as Lapland, and as far south as Barbary.

On the continent many others have been tried, with more or less success; and I see but little reason why many should not be cultivated largely in this country, and enable us to enjoy a good supply of delicious food, which is now entirely neglected. *Boletus edulis* is cultivated largely in Paris, simply by watering the ground under oak trees with water in which a quantity of the Boleti have been allowed to ferment, the only precaution necessary being to protect, by fencing, the ground destined for their production, as deer, pigs, and rabbits are very fond of them; this plan is said to be infallible, and much practised in France. In Germany, the *Morels* were so much esteemed, that the peasants who collected them, observing that they grew most abundantly where wood had been burnt, set fire to large forests to

favour their growth; and to such an extent did this injurious practice proceed, that it became necessary to enact severe laws for its suppression. The *Truffle* has been cultivated on the continent with more or less success; a light, dry soil appears most favourable to its growth; but, like other fungi in their natural state, it is a most capricious plant.

It is well known that serious accidents have arisen from the careless way of collecting and preparing fungi for the table (which I shall endeavour to explain in a future paper on the Poisonous Fungi). For collecting, therefore, fine dry weather should be preferred, and those should be chosen cautiously which grow in wet, shady, and unhealthy situations, although they are well known to be wholesome species; those being preferred which are found in open, dry situations, and exposed to light and a free current of air. A flat-bottomed wicker basket, with clean cloth, as used in the south of England in the markets for eggs and butter, should be chosen, also a house-painter's brush should be provided, to remove dust, dirt, leaves, insects, &c., and a knife to remove the roots; the stems may be cut off close, and should generally be rejected, and the fungi may then be closely packed. They should always be gathered before fully grown, and all that are maggoty, or attacked by insects, also all that have been dislodged from their resting-place by boys or cattle, should be rejected. Having obtained as many as required, they should be conveyed home, and, with as little delay as possible, prepared for the table, or preserved for future use.

I find space will not allow me, as I intended here, to enumerate those most esteemed as food in different parts of the globe; I shall, therefore, defer it to my next paper, which will also contain receipts for cooking.—F. Y. Brocas.

(To be continued.)

THE HONEY HARVEST.

I BEG to offer my mite to the common stock. Up to the month of July, I never knew so bad a season since I have had bees. An agreeable change at that time took place, we had copious showers of rain, and then splendid weather to the end of the month; after which the honey gathering season is about over in this locality, as it is principally an hay-growing district.

My No. 1 swarm, an artificial one, was taken off June 19th, and put into one of Taylor's Bar Hives, and placed where the stock formerly stood (according to the "Country Curate's" plan, which answered very well in preventing any casts from coming off). But there is danger of over-doing it, as a neighbour of mine did, as in his case there were not bees enough left to defend the hive, which was attacked by a neighbour's bees, who succeeded in carrying off every particle of honey, in spite of narrowing the entrance to the hive. However, I could not, by any means, induce them to work in the super, although the stock-box was full of honey, nearly down to the floor-board. So I fumigated them, and took two bars of comb out weighing 7 lbs.

No. 2, also an artificial swarm, taken off June 23rd, into a common cottage hive, plundered it the middle of August, and took 18 lbs. of honey from it.

No. 3, natural swarm, June 25th, which was a very small affair, as we did not see it go off, but found it hanging from a tree close by, late in the evening, and I suppose the principal part of the bees had returned back again to the parent stock. I supposed, by placing the swarm in the stock's place, I should get plenty of bees to it. But I was woefully disappointed, for a most deadly warfare commenced. The result was the loss of a greater part of the bees. Can any of your readers account for the fighting?—the swarm must have come out of the hive that I attributed it to, there being no other at all likely. (But I observed fighting, more or less, at all the swarms that had been put where the stock formerly stood.) From this swarm I took 12 lbs. of honey, by destroying the bees.

No. 4, a Nutt's Hive, the bees of which I could not induce to work in the side-boxes. Swarmed July 1st; hived it into one of the side-boxes, thinking it would commence working

there; but no, the next morning I found them all united in the centre-box again. At the end of seven days, that is, July 8th, it swarmed again, and a magnificent swarm it was, and I hived it into a common hive. In the course of a week I placed an eke under it, and at the end of fourteen days it swarmed. From this swarm I took 28 lbs. of honey. The same Nutt's Box threw off a cast, a few days after which I hived it into a straw cup. From this I took 6 lbs. of honey, by fumigating it, and adding the bees to one of my stocks, as I considered they would be principally young bees, and might be of some service. I have abandoned the plan of adding the bees that I plundered to those intended for stocks, as I could see no benefit from it the spring following. I consider they only help to eat up the food of the stock, and then die before they are of any service to the stock, unless bees live to a greater age than is generally supposed.

By-the-by, I saw a notice a short time ago, in THE COTTAGE GARDENER, that the Entomological Society had offered a prize for the best treatise on the longevity of bees. I am anxiously waiting the result. I think it a very good bit of the "Country Curate's," to preserve the brood from the hives you are plundering. I took mine carefully out, and arranged it upon the top of two of my stocks, then placed empty hives over it, and the bees presently came through, and hatched it out, which appeared to strengthen those stocks very much.—H. T. N.

P. S.—I have just seen a drone bee go into my No. 1 stock (Sept. 25th). I saw a great many the beginning of this month. Do you think they are without a queen? if so, what will be my best plan with them?

NEW MODE OF MANAGING BEES.

I HAVE much pleasure in complying with your request, and forward you the following particulars relative to the method adopted by me at your suggestion, in the case of the only four swarms which came off in my apiary. As soon as the swarms had left the hives, the stocks were stopped up; the swarms, as soon as hived, put in the place of the stocks, and the stocks removed a short distance, and kept closed from 24 to 36 hours.

No. 3 sent out, 19th June, a swarm weighing 5½ lbs. On unstopping it, the workers began to eject the drones with frightful rapidity, no other kind of work was carried on, and the hive, for we could see into it on the back side of the box, appeared clear of them in a few days. On the 14th day from swarming, a few were seen; on the 20th, piping was heard; and the following day a young queen was cast out. On the 26th July, some of the old combs were removed, from which 4¼ lbs. honey were run; 1½ lbs. of bees was added to this stock on the 26th August, and 3 lbs. sugar, and 1½ lbs. honey, prepared as directed in Golding's Is. Bee book, was supplied previously to the 1st September, when it weighed 9¼ lbs. From the swarm No. 19, ten pounds of honey were run on the 19th August.

No. 13 sent out, 19th June, a swarm weighing 4¼ lbs. Immediately on its being unstopped, drone ejection commenced, and in a few days the work appeared to be completed. On the 30th July, some combs were removed, from which 3 lbs. of honey were run. No drones were then seen. As this stock did not appear to progress well, it was taken up on the 4th August, but contained no honey, no brood, no queen, and only half a pound of bees. The swarm, No. 15, was deprived, 29th July, of 7 lbs. of honey. No. 6 sent out, 1st July, a swarm weighing 4½ lbs. The pan on top was removed, and as it contained comb with drone and worker brood, and royal cell with princess, it has, with the addition of 2½ lbs. of bees and feeding, made a little stock. As soon as the parent-hive was unstopped, the workers threw out, in the course of two or three hours, between six and seven ounces of drones. No honey has been taken from this hive, 1¼ lbs. bees was added 24th August, and it weighed, 1st September, 12¼ lbs., or a little more than one-half of what it weighed 1st September, 1851. The swarm, No. 4, was taken up 24th August, and yielded 7 lbs. honey.

No 2 sent out, 3d July, a swarm weighing 4¼ lbs. Drone ejection was proceeded with, as in the three cases above-named, with great rapidity. Removed side-combs, 30th

July, and ran 2½ lbs. of honey. No brood was observed. On the 5th August, added ¾ lb. bees; 26th August, 1½ lbs. bees. Prepared food, 5 lbs. sugar, 1½ lbs. honey, was given previous to 1st September, when it weighed 7 lbs. From the swarm No. 16, when taken up 24th August, 7¼ lbs. of honey were run.

No cast has issued from either of these hives. My assistant and myself, in thinking over the case of No. 13 within the last few days, have considerable doubts as to the existence of any royal cell in it. On taking up No. 7, that had not swarmed, none was found. I must leave you to judge of the merits or demerits of the new mode. On these particulars you may rely. It is my intention to try it again next year, but I would not recommend it to be adopted with all the stocks in an apiary, since, from the wholesale and sudden expulsion of the drones, and the uncertain nature of our climate, the requirements of the queen might not be met in time. Huber, if I remember rightly, states that this should be within thirty days.

I send you herewith an account of what twelve stocks and four swarms have done with me, North Bucks, and having had under my notice from fifty to sixty other hives that have been taken up, a very large portion of which I fumi-

gated myself, I am of opinion that my own apiary presents a more favourable report than I should have been able to give, could I have ascertained in all cases the weight of honey run from each hive. In many cases of stocks and swarms, of which I have heard, it has varied from four to six pounds. I fear there are very few stocks or swarms in this locality that can stand the winter without feeding. I shall hope that we may be favoured next year with a season as productive as that of which C. R. R. writes. Query. Does he weigh his hives, swarms, honey, &c.? As accuracy is so essential to the formation of correct opinions, I would suggest to him and your other correspondents, to avoid in future the terms "very large," "enormous," "amazing quantity;" the ideas they convey are so vague. A bee-keeper of forty years standing sent me, as he said, an "enormous" quantity of bees, and laid a wager, for which I reproved him, with the person who brought them, that they weighed 5lbs. I weighed them accurately, and they were found to be only 2¼ lbs.

P. S. I should feel much obliged to C. R. R. if he would give me the size of his "very large" hive, the weight of his "enormous" swarms, as well as that of his "amazing quantity" of honey of other sorts than top honey.

Particulars of Twelve Stocks and four Swarms.—Season, 1852.

Description and kind of Hive used.	Wt. 23rd April, 1852.		Wt. 23rd June, 1852.		Year of the queen's birth.	Honey taken from top in glasses or pans.	Honey taken by the removal of combs.	Honey run from combs on taking up hive.	Bees added Aug., 1852.	Prepared food supplied in August, 1852.		Wt. 1st Sept., 1851.			Remarks.
	Sug.	Hon.	Wt. 1st Sept., 1851.	Wt. 1st Sept., 1851.						Wt. 1st Nov., 1851.					
STOCKS.															
1. In Neighbour's cottage hive - -	9	..	1851	g. 7½	1½	23½	27½	24	24	24	Swarmed and cast, 1851; cast returned; 7¼ lbs. comb in glass taken, 1851.
2. In straw-hive, wood top, 12 by 8½ in. -	4½	12½	1850	..	2½	..	2½	5	1½	7	..	14½	14½	14½	Two swarms 19th June, 1851; 14½ lbs. comb taken in small hives in 1851.
3. In Taylor's bar-hive, 11½ in. sq. by 8½ in.	6	5½	1851	..	4½	..	1½	3	1½	9½	16½	15½	15½	15½	Sent out a swarm of 7 lbs. 21st June, 1851; 3½ lbs. honey taken from side combs in 1851.
5. In straw-bar hive, wood top, 15 by 10 in.	8½	15½	supd. 50	1½	25	18½	24	24	24	Formed from 7 lbs. bees put into empty hive at various times, between 11th and 18th Aug., 1851.
6. In common straw-hive, 12 in. by 8½ in.	11½	16½	1851	1½	12½	25	23½	23½	23½	Swarmed and cast, 1851; 1½ lbs. comb in glass, taken in 1851.
7. In do. do. do. -	7½	..	supd. 50	g. 2 p. 6½	12	19	19	19	Formed from 7 lbs. bees put into an empty hive at various times, between 26th August and 8th Sept. 1851.
8. In straw-hive, wood top, 14 in. by 7 in.	4½	..	1850	..	3	12½	..	14½	14½	14½	Swarm of 1st of June, 1851; deprived of 13½ lbs. honey, and fed freely for winter of 1851; cast of 2 lbs. added 17th June, 1852.
9. In box diag. bars, 11½ in. by 6½ in. -	6	..	1851	g. 6	3	25½	18½	17½	17½	17½	Two casts of 1851; no honey taken in 1851.
10. In straw-hive, wood top, 12 in. by 8½ in.	3½	10½	unkwn.	9½	13	13	13	Stray swarm of 1851 purchased 19th June; no honey taken in 1851.
11. In do. do. do. -	7½	11	1851	g. 1	14½	22½	20½	20½	20½	Swarm of 21st June, 1851, weighing on that day 6½ lbs.; no honey taken in 1851.
12. In common straw-hive, 12 in. by 8½ in.	9½	10	supd. 50	6½	16	16	16	Did not swarm, 1851; no honey taken in 1851.
13. In do. do. do. -	5½	4½	1851	..	3	Nil	15½	15½	15½	Cast of 2 lbs. 23rd June, 1851; no honey taken in 1851.
SWARMS.															
14. In Taylor's bar-hive, 11½ in. by 8½ in.	1851	10	This hive increased from 3rd to 10th July, 8½ lbs.
15. In common straw-hive, 15 in. by 7 in.	1851	..	7	12	4	15½	This hive increased from 3rd to 10th July, 9½ lbs.
16. In do. do. do. -	7½	This hive increased from 3rd to 10th July, 6½ lbs.
4. In straw-bar hive, 12 in. by 8½ in. -	7	This hive increased from 1st to 10th July, 9½ lbs.
..	22	23	52½	7½	20	6½	145½	

I cannot speak with certainty respecting all these hives, but, judging from the eight which I weighed several times, I am of opinion that they have, on the average, decreased since the 18th July. Looking at the above statement, it is evident that had no honey been taken from these 16 hives

they would, after consuming 20 lbs. sugar, and 6½ lbs. honey, and receiving 7½ lbs. bees, have only weighed on the 1st September, 1852, 243 lbs., or 77 lbs. less than they should have done to stand the winter. Your readers must form their own judgment from these facts.

B. B.

THE LIVERPOOL POULTRY SHOW.

THE fifth annual show of the Manchester and Liverpool Agricultural Society was held on the 23rd of September, in the capacious Market Place, in Great Homer-street, Liverpool. For the first time, the Society added a show of poultry to the other attractions of its Exhibition, and we congratulate them on the success of their first experiment in this interesting department of rural economy. This, as our readers are aware, is not a good time of the year for showing to advantage their feathered favourites, but, making reasonable allowance for this drawback, this new feature of the Society's exhibition was highly creditable. As is our usual practice on such occasions, we proceed briefly to notice each class. The *Dorkings*, which were the first class here, presented some good pens of fowls, the prize being awarded to Capt. W. Hornby, for three very good birds. The same gentleman carried off the prize in the *Spanish* class, in which there was nothing approaching in excellence the birds exhibited by him; and he was equally successful in the *Game* class, against two or three very good competing pens. In the *Cochin* class, the prize was very deservedly given to Dr. Gwynne, of Sandbach, for three very fine fowls; this class altogether was not first-rate. Of *Malays*, there were none shown, and the *Hamburgh* and *Poland* classes were not good enough to deserve notice. The *Geese* came next, and Mr. Townley Parker again carried off the prize, as he did also in the class of *Goslings*—Capt. Hornby running him very close in both classes. Capt. Hornby obtained the prize for *Aylesbury Ducks*—those for *Rouens*, and for "any other variety," being awarded to very good pens belonging to Mr. Henry Worrall. One pen of *Turkeys* only was shown, by Mr. E. W. Wilmot, but they were excellent, being of the "wild American breed." In the *Duckling* class, the prize again fell to Capt. Hornby, for six beautiful *Aylesburies*; Mr. Townley Parker's *Rouens* being but little inferior to them. In the class of "six chickens," some very fine birds of several varieties were shown, and the judges gave four prizes. Three of them were awarded to Capt. Hornby, for *Cochins*, *Dorkings*, and *Spanish*, respectively, and the fourth to William Copple, for *Bolton Greys*. The Society's medal for the best pen of birds in the yard, was adjudged to Capt. Hornby, for his six *Cochin* chickens, making the tenth prize obtained by him; a proof of what may be accomplished by the judgment and attention of an individual fancier.

With the exceptions to which we have referred, there were some good birds shown in each class, and we have no doubt that the success of this, their first attempt, and the interest excited by this portion of their exhibition, will induce this spirited Association to repeat the show of poultry in succeeding years; and that as the interest taken in them increases, and the encouragement given by the different Societies is extended, the different breeds of domestic fowl will be improved, and disseminated throughout the country.

The judges were Mr. Bissell, of Birmingham, and Mr. Nolan, of Dublin, and their decisions appeared to give universal satisfaction. The arrangements of the show by the secretary, Mr. White, were very judicious, and the poultry pens were as good as we have seen anywhere.

LIST OF PRIZES.

- One male and two female birds to be shown by each competitor.
- For the best white, speckled, or grey *Dorking Fowls*, £1. Captain W. W. Hornby, Knowsley, near Prescott, pen of fowls, of the *Dorking* breed, aged about 2 years.
- For the best *Spanish Fowls*, £1. Captain W. W. Hornby, Knowsley, near Prescott, pen of fowls, of the *Spanish* breed, aged about 2 years.
- For the best *Game Fowl*, £1. Captain W. W. Hornby, Knowsley, near Prescott, pen of fowls, of the *game* breed, bred by himself, aged 2 years.
- For the best *Cochin-China Fowls*, £1. William Cust Gwynne, M.D., Sandbach, Cheshire, three fowls, of the *Cochin-China* breed, bred by himself, and hatched, the cock at the end of March, and the pullets at the middle of March. On sale. Price £20.
- For the best *Malay Fowls*, £1. No entries.
- For the best *Golden-pencilled Hamburgh Fowls*, £1. The variety called "Bolton Bays" or "Golden Hamburgh" fowl, must be exhibited for this premium. No entries.
- For the best *Silver-pencilled Hamburgh Fowls*, £1. "Bolton Greys," "Chitterprats," and "Silver-pencilled Dutch," to be shown for this premium. John Taylor, Halshaw Moor, near Bolton, pen of fowls of the *Silver-pencilled Hamburgh* breed, bred by William Hill, aged 4½ months.
- For the best *Gold-spangled Hamburgh Fowls*, £1. "Golden Pheasant,"

"Golden Mooneys," "Copper Moss," and "Red Caps," to be shown for this premium. R. C. Lowndes, Club-moor, near Liverpool, pen of fowls, of the *Golden-pheasant* breed, bred by himself.

For the best *Silver-spangled Hamburgh Fowls*, £1. "Silver Pheasant," "Silver Mooney," and "Silver Moss," fowl, to be shown for this premium. No award.

For the best *Poland Fowls*, £1. Black, with white crests, golden or silver. No award.

For the best of any other breed or cross of *Fowls*, £1. The breed to be stated on entry. Captain W. W. Hornby, Knowsley, near Prescott, pen of fowls of the *Gold-laced Bantam* breed, bred by himself, aged 1 year and 3 months.

GEESE.

For the best *Geese*, £1. Thomas Townley Parker, Sutton-grange, near St. Helens, geese of the common breed, aged 3 years.

DUCKS.

For the best *Aylesbury Ducks*, £1. Captain W. W. Hornby, Knowsley, near Prescott, pen of ducks, of the *Aylesbury* breed, bred by himself, aged 1 year and 4 months.

For the best *Rouen Ducks*, £1. Henry Worrall, Knotty-ash House, Liverpool, pen of ducks, of the *Rouen* breed, bred by — Henderson, Esq., aged 8 months.

For the best of any other variety of *Ducks*, £1. Henry Worrall, Knotty-ash House, Liverpool, pen of ducks, of the crossed wild breed, bred by himself, aged 1 year and 1 month.

TURKEYS.

For the best *Turkeys*, £1. Edward Woollet Wilmot, Hulme Walfield, near Congleton, pen of turkeys of the wild American breed, hatched April, 1851.

YOUNG POULTRY.

The day on which they were hatched to be stated.

For the best *Six Goslings*, £1. Thomas Townley Parker, Sutton-grange, near St. Helens, goslings of the common breed, bred by himself, hatched on the 10th April last.

For the best *Six Ducklings*, £1. Captain W. W. Hornby, Knowsley, near Prescott, pen of ducklings, of the *Aylesbury* breed, bred by himself, aged 4 months.

For the best *Six Chickens*, £1. Captain W. W. Hornby, Knowsley, near Prescott, pen of chickens, of the *Cochin-China* breed, bred by himself, aged 5 months and 5 days.

Captain W. W. Hornby, Knowsley, near Prescott, pen of chickens, of the *Dorking* breed, bred by himself, aged 4 months.

Captain W. W. Hornby, Knowsley, near Prescott, pen of chickens, of the *Spanish* breed, bred by himself, aged 5 months and 1 week.

EXTRA PRIZE.

For the best pen of Poultry in the show yard, the Society's SILVER MEDAL. The judges awarded it to Captain W. W. Hornby, for *Cochin-China* chickens.

NOTES UPON BACK NUMBERS.

THE *Palma Christi* is not difficult to grow as an out-of-doors plant. It should be raised in the spring hotbed, shifted once liberally, and treated exactly as a balsam till the frosts are over, when it should be planted out in very rich soil, or what would be still better, plant it like a vegetable marrow, with a barrowful of hot manure beneath the soil. Many other tropical plants would grow and show their fine foliage in the summer time if treated thus, and there is not a handsomer one than the *Palma Christi*. All laterals and blossoms should be carefully removed till the plant is four or five feet high.

The *Hybrid Begonia parviflora* by *Cinnabarina*, is now in flower in my stove. It is a miniature *Cinnabarina* in habit, more branched and flowery, but inferior in colour. The pollen of *Cinnabarina* colours some of its mules highly, but others not so well.

Funkia subcordata will not flower satisfactorily out-of-doors, and generally not even in the greenhouse, the flowers being usually deformed by the curling or unequal expansion of one side of the flower. In the stove there is not a more exquisite plant. The flower is of the whitest white I know, the scent delightful, and the leaf a form for the sculptor. Small plants do the best, grown from pieces broken off from the mass in the spring, and each containing one, or at most two crowns.

Your correspondent's "black *Geranium*" was probably *Hoarea melanantha*, a weed, in fact, as he says, but some pretty mules were raised from its pollen some years ago. He must not be cross about his first turn at African bulbs. They, and all imported bulbs, are hard to establish, even for an old hand, sometimes. These little Africans are highly interesting plants, and the time will come, and that soon, when everybody will be running after them again.

Our good instructor, Mr. Beaton, alludes to a tropical experiment of mine. It was not, however, an old hotbed, but a new one made for the purpose, only very spacious and

shallow; one foot was the depth of hot dung, but this was trodden very firmly down on the brick bottom, and enclosed by a little brick-wall to that height. I wished to try if a large and shallow mass would produce and retain the heat as well as the same quantity in the usual more cubical shape, and I think it did so. Most of the tropical plants likely to be experimented upon, such as the South American *Scitamineæ*, and the like, would, if our climate continued as it is to day, be in their beauty, as to blossom and good development, about Christmas day. We, therefore, try to give them such a start, by means of the bottom-heat, as will enable them to begin soon enough to be ready to flower and thrive while our fine weather lasts; but this, the perfection of the thing, will not be done till we try Mr. Beaton's plan of a cheap and simple means of bottom-heat, always at command; while above ground, the plant enjoys what it never gets in our plant-houses, fresh air and exercise. Many men have many minds, and so have the many members of the large family *Amaryllis*. Scarcely any two require exactly the same treatment. The name of the sorts should be given to prevent poor Editors giving evasive answers. Much of this difficulty will cease when warmed borders in the open — In two minutes I shall be on my hobby, so adieu.—A CORRESPONDENT.

(From whom we hope to hear very often.—Ed. C. G.)

MR. RIVERS'S CRYSTAL PALACES.

To gardeners and amateurs. You are all well aware of the annual trouble and expense of fruit-trees on walls, after pruning, nailing, and covering (*but not protecting*), for that is almost an impossibility in our northern parts, and frequently is an entire failure in the more southern districts. Gardeners have been for years crying out—"I'm afraid I shall not be troubled with much fruit this season, as my peaches, pears, plums, and cherries, all apparently are cut off by the frost, and it's nothing but an entire disappointment." Now, to prevent all this, I would earnestly recommend all horticulturists and lovers of gardening to step into Mr. Rivers's nursery, and see there fruit grown to the greatest perfection, such as peaches, plums, pears, apricots, and apples. I, myself, was highly gratified, two months ago, by a visit to his nursery, likewise, at the same period, to the seat of Lord Roden, where I saw, in both places, peaches and apricots in pots, laden with admirable fruit. What would be more pleasing and interesting than to have one or more of these pots, with the sides washed, and the surface covered with a carpet of moss, placed on a nobleman's table, with three to four dozen of beautiful fruit on each plant, which is very easily to be had with only a slight attention. There is no nailing, no tying, and no covering at night with these, only a little additional watering and pruning, as our kind friend Mr. R. directs. And I am sure that the ladies would take great pleasure in gathering the fruit themselves in their dining-rooms. Some are apt to say that the "orchard-houses" are nothing more than rickety cow-sheds, but for them to be convinced about that, I should strongly recommend them to pay one of these structures a visit. Perhaps some of our aged friends, in the same capacity of gardening as myself, would like to know how Mr. R. manages to produce his fruit so abundantly, and if they inquire of him, I have no doubt he will inform them, as I know he is always pleased to give any one information concerning their well-doing. I can safely say, that I could grow fruit in the same way very satisfactorily, although not of so much experience as some; but I hope, as glass is so cheap, that I shall be able to see, one day or other, an orchard-house as large as the Crystal Palace that stood in Hyde Park.

A. B. C.

POULTRY MANIA.

DORKING, *versus* COCHIN-CHINA.

"*Tantas componere lites.*"

(To decide so great a controversy.)

Virgil's Eclogues.

COCK-FIGHTING, as a national pastime, has become defunct, and in lieu thereof, the owners of cocks have entered into strife among themselves; happily, however, the fight

is a bloodless one, and *in the main* is limited to ink-shedding. Most learned have been the controversies, most conflicting have been the facts; and but one truth stands conspicuously forth, namely, that a fowl which passes under the name of "Cochin-China," is just now "the pet of the fancy." We hate foul play, and, therefore, candidly confess, that *why* this has come to pass we cannot determine. Vulgar people insinuate, that it arises from a vain desire to imitate Majesty in small things; and just as the daughters of the honest burgesses of this realm, on all occasions, threw back their veils in a coil around the sides of their bonnets, and tied them in a knot under their chin, on hearing that the Queen, *in a stormy day*, was seen with the bonnet thus accoutred, so have "Cochins" become the fashion, because a few "noble specimens" of the breed occupied a conspicuous position in Her Majesty's aviary. We reverence royalty, wherever we find it. When a king squints, it becomes his subjects to squint likewise. We have heard of a courtier who said he would bow to a thistle, if it were surmounted by the crown of his sovereign. We honour the sentiment. Where is the hungry donkey that would not perform a like act of homage?

But to return to the Cochin-China fowl; what are its qualities? In what special excellence does it transcend the whole race of Spanish, Dorkings, Polands, or Game? In size—in that estimable quality in which a painted sign-post surpasses one of Mulready's cabinet pictures—in that important endowment in which Daniel Lambert was superior to Lord John Russell, and in which the elephant surpasses a man. All its qualities are colossal; and, therefore, in an age when people wish "to get *as much* as they can for their money," they are popular, fashionable, and "the pet of the fancy." It is true, that when they are young, they are superlatively ugly; when at adult age, superlatively tough; and when old, these two qualities are blended in a superlative degree. But *then*, they are very large, very dear, and very fashionable; and these qualities, with the majority, are sufficient to compensate all other defects. The poultry-shows, generally, proclaim that these tailless birds are, as we have described them, "pets." They have all the "prestige" of novelty. All the fervour and enthusiasm which Englishmen lavish on foreign favourites, whether Italian singers, French ballet-girls, Swiss valets; or German nurse-maids, are now bestowed on these emigrants from India, Cochin-China, and the Malay peninsula. Their names appear daily in large capitals in the advertising sheets of the *Times*, the *Gardener's Chronicle*, and other first-rate journals. Mr. Stevens, the auctioneer for all the property connected with natural history in its wide-spread ramifications, exhausts his oratorical powers in their praise; and every dandy who hears of poultry-shows exclaims—"Aw, I've no taste for these things, except, aw, except for Cochins; the rest are low, sir, decidedly low." And yet, in spite of all this dilettanti dandyism—this popular favour—we venture to predicate, that the Cochin-China fowl will disappear as such;—like the Arab horse in England, it will become lost in crosses with other breeds, and be represented by a race possessing their great size, without any of the numerous defects which now characterize the bird.

During the past summer, we saw a Cochin chicken running about at three months old, with "dowl" upon his back, with legs nearly as long as a Flamingo's, and as bare behind as a picked goose. He had, it is true, "roughed it" bitterly, and, therefore, did not resemble very closely the pets of Sturgeon and Punchard—yet he was a genuine Cochin; and around him, reared under, and exposed to precisely the same influences (birds of the same nest and hatch), were gaily congregated chitteprats, half-bred game chicks, and a host of mongrels, carrying in their veins as heterogeneous a mixture of vital fluid as rolls in the arteries of a Yankee, and yet these were all well-feathered, respectable, and decorous, waving their tails with modest dignity, while the unfortunate Cochin ran about as bare, if not as ornamental, as that variegated baboon, who rejoices in the euphonious name of "Cynocephalus maimon." It would become the exertions of benevolent young ladies to make flannel coverings for these ornithological nudities, if such a breed is to be encouraged to the exclusion of the more useful and ornamental denizens of the poultry-yard.

A short time ago, some Cochin-China fanatic was awfully angry with the Royal Agricultural Society for placing the "Dorking Fowl" in Class A of their prize list, instead of the Cochins; but what *could* a farmer do with a lot of naked Cochins? He requires a breed that shall come early to maturity, and weigh heavily, and lay well; and in these particulars the Dorkings far surpass the "pet of the fancy." A Dorking pullet, hatched in April last (12th), within one hundred yards of the unfeathered Cochin above referred to, weighs, at this date, six pounds, and has laid eggs every alternate day for the past three weeks. *This is the breed* for the agriculturist; and the Society has acted wisely and well in their selection and arrangement of the prize list; for if a genealogy, stretching back for centuries, even far beyond the age of the learned Aldrovandi; if associations, classical as the Bard of Avon's writings can make them; if the authority of Pliny and Columella can outweigh the ephemeral opinions of the fashionable dandyism of the present day; or, what is far more to the purpose, if beauty of plumage, early maturity, great size, fecundity in eggs and chickens, whiteness, and delicacy of flesh, constitute claims for preference in the gallinaceous tribes, then, may the high-bred speckled Dorking calmly "abide its time," and treat with proud and becoming indifference the popular mania in favour of the long-legged, tough, tall, and tailless Cochin-Chinas. Such, at least, is the *modest* opinion of
Mickleover, Sept. 22, 1852. AMICUS GALLI.

FAMILIARITY OF BIRDS.

The Robin.—The nursery ballad on the "Children in the Wood," has done much for the protection of the Robin. He is a bird which never congregates, but is widely spread; and there are few localities in the country that are not enlivened by his presence. He is a general attendant on the gardener, particularly on the operations of the spade, in search of worms and insects. He is very familiar, and, if encouraged, soon becomes half-domesticated. For two or three years a robin formed one of my family; seldom did I sit down to a meal without his being on the table. He would enter the house by any door or window, and watch his opportunity to pass into the room as the servant brought in the dishes. At other times he would appear at the parlour window, and on being admitted, would fly to my knee, or perch upon the book I was reading; but his favourite post was the lid of a lady's workbox, and among its contents of bobbins and reels of cotton he would find great amusement. Upon this lid he would warble by the half-hour together, in soft, musical notes, which, at times, appeared to come from different parts of the room, as though he was a ventriloquist. He would feed from the hand, and was not disturbed by the movements of the family.

The Chaffinch.—Another of my familiar acquaintance was a hen Chaffinch, an almost constant visitor. One morning she brought, for my amusement, her little family of four young ones, and having arranged them in a row on the breakfast table, commenced feeding them. After their repast a difficulty arose; she wished to withdraw them, but they remained immovable, and it was interesting to observe her endeavours to accomplish this object, flying in and out of the room, and calling to them, but without avail. They appeared to enjoy their position, and were deaf to her solicitations; at length, one of them flew out, and the rest followed in succession.

The Jackdaw.—One day a female of my family, on visiting a neighbouring farm, brought home a young Jackdaw, which had been caught by a boy. He was turned loose in the garden, and but little thought of him. He grew up, however, very sociable, and though he had full use of his wings for six years, he never left us, and was found dead at last on the gravel walk, apparently killed by a stone. His first concern of a morning was to call me up, by tapping at my chamber window; he would then attend me in my rounds before breakfast, to pick up the earwigs, as they were emptied out of the flower-pots, placed as traps on the tops of the dahlia stakes. He invariably assisted in our garden operations, seizing the small worms, grubs and insects. During the day, his favourite resort was an elm tree by the road-side, and his great delight consisted in holding collo-

quies with the children as they went to, and returned from, school. He would visit the neighbouring cottages, particularly if any workmen were employed about them; would sometimes accompany his mistress to church, which he was with much difficulty prevented from entering, and became at length so troublesome, that on these occasions he was obliged to be shut up: if at liberty, he would watch for her return, and call to her the moment he saw her among the crowd. He would meet me on my coming home from a neighbouring town, and fly for a mile by the side of my gig, uttering "Jack." He would attend me in my country walks, sailing over my head, and alighting on some tree in advance to invite me onwards. When drinking tea on the lawn, he would testify his joy by exhibiting all manner of gambols, sometimes over our shoulders, sometimes hiding himself in the folds of a lady's dress, but generally ending in seizing a slice of bread and butter, and flying off with it. His faults were—his over-familiarity, and making too free with what did not belong to him. Few animals exhibited greater sagacity; he knew when he had done wrong; his life was a system of schemes and contrivances, and his death a family loss.

To those who are fond of studying the habits of birds, and whose position in life enables them to indulge in it, a delightful source of instruction and recreation may be found in cultivating their familiar acquaintance.

S. P., Rushmere.

TO CORRESPONDENTS.

PROLIFICACY OF COCHIN-CHINA FOWLS.—Mr. E. George, of the Rookery, Chaldon, says, "Being a breeder of light-coloured Cochin-China fowls, perhaps you will permit me to add my testimony in their favour, which I think your readers will allow the following facts to be. I have had seventy chickens, from one hen, since the end of February last, besides using some of her eggs in other ways, and one dozen now hatching; and, to my own knowledge, she has laid a double-yolked egg and a soft-shelled one within twelve hours. I have had a brood of chickens from eggs of a pullet hatched the middle of March last; cockerels of same age weighing above *nine pounds*; pullets six pounds; and others, a month younger, five pounds and three-quarters. As to their hardihood, I can only say the numbers we have lost in rearing does not amount to seven per cent., and nearly half of those have been accidents, such as getting into the wrong coops, and being killed by the hen, &c. Now and then a bird will gain weight even faster than those already mentioned: for instance, a cockerel, which I exhibited at Lewes, has continued to gain more than an ounce a day ever since."

HENS NESTS.—Mr. W. J. Beeby, of Chaldon, near Coulsden, Surrey, says, "Referring to former numbers of your periodical, in which it has been endeavoured to show the best place for setting eggs, allow me to remark that, having kept the Cochin-China fowls the last five years, I have set the eggs on the bare ground, in wooden boxes on the ground, and, lastly, in wooden boxes raised from the ground, and (by way of experiment) lined with kamptulicon, (a composition of India-rubber and cork); and I am of opinion that a hen will hatch equally well in either of the above situations, if comfortably placed—the number of chickens brought forth depending entirely on the health of the layers and sitters. Can you tell me whether there have been any of the Cochin-China fowls imported of a pure white colour, with top-knots? Fine specimens of this variety are to be had at Hong-Kong and Shanghai, as I am informed by a party who has been at those places." We have not seen or heard before of white Cochin-China fowls with top-knots. We saw a buff one the other day with a slight tuft of feathers on the head; but we think it was symptomatic of a cross in the blood of one of its parents.

DATURA JUST BLOOMING (*Greenhorn*).—In the first place, give it abundance of water all the time that it is in bloom, and, as we are so near the winter, cease watering altogether as soon as it is out of flower; the leaves will soon droop, and the plant will look deplorable for ten days or so, but you may smile the while. If the leaves do not fall in ten days after the drooping, pull them off, and let the plants stand naked all the winter, and, unless the green top branches begin to shrivel, you need give no water; but if they do, give the pot a good soaking, to keep the tops fresh for cuttings. Any time in March or April, when you have a cucumber bed at full work, cut down your *Datura* as far as you like—or say, at a venture, to within a few inches of where it began to grow from last season; then with a thick paint made with water, soft soap, a little sulphur, and a lump of clay, cover the whole body of the plant, and let this remain as long as you can—it is to kill and keep off insects. Every joint of the tops will make a cutting; but you had better keep two joints to a cutting when the joints are far apart—one joint at the bottom for roots, the other for leaves; and so, when the joints or eyes are close on each other, make the cuttings four or five inches long. They like a brisk bottom-heat, but not much water.

MAURANDYA BARCLAYANA (*Ibid.*).—It is a perennial, and it may be cut in a good deal, and taken up and potted, but not cut down altogether. Keep a foot or so of the main stem, or stems, and six inches of as many of the side branches as you can train without crowding; and if there be any very small branches near the root, keep all of them, and at their full length. You had better do all this cutting at once, but let the plant remain to the end of October. One of the greatest errors in gardening at the present day is cutting in, or pruning, any plant, except the very commonest thing—as a laurel—the same day, or the same week, as it is to be potted from the borders, or transplanted elsewhere; *Maurandya* particularly so, as they make such long wiry roots, with few fibres; but

few plants deserve to be kept from year to year more than they. They also want to be in a cool, airy place all winter, and not get much water until you see them grow away freely. We are going to keep all our old plants of *Maurandias*, *Lophospermums*, *Ecceumocarpus*, and *Cobseas*, this winter. We shall have them in different lengths, from one to ten feet.

FLOWER-BEDS (S. S.).—We are going to give plans of different kinds of flower-gardens, single beds, and angle beds, and groups; and, to open the way for all this, we only propose, at first, to engrave actual flower-gardens as they now stand, with accompanying criticisms and suggestions. Your plan will appear in the series as a good example of a very useful way of making the best of a limited space of ground; meantime, we shall file your letter, to see what we can do for what you want most.

CHRYSANTHEMUMS (Lora).—“How soon is it advisable to force them; I have a large stock, and grow for show in greenhouse only?” They stand no forcing. From the 15th to the 25th of October we have put those with earliest flower-buds into a house, with doors open at both ends night and day, and we gained nearly a week, which was a great feat.

GERANIUMS IN POTS (Ibid).—“These are intended for show in greenhouse; mine are already cut down, thinned, and kept outside. When should I take them to the greenhouse?” As soon as you see your well-arranged letter in print.

CINEBARIAS (Ibid).—“Some of my varieties, and all my *Flora M' Ivors*, show appearance of either dry mould or mildew on the leaves (which are most luxuriant). I have sponged the leaves, and removed the diseased plants out of the greenhouse into a cold frame; have I done right?” Quite right; keep them in a dry, cool air, and dust them with flowers of sulphur.

AGAPANTHUS UMBELLATUS (S. S. S.).—Take it up about the end of October, but March is time enough to divide it, unless you are in a great hurry, when you may take the spade any day in the year, and part it into single plants.

PLANTS FOR TRELIS (Ibid).—Plant one *Clematis montana*, one common *Honeysuckle*, one *Felicite Perpetuelle Rose*, then one *Japan Honeysuckle*, and the last a *Sweet-scented Clematis*, as permanent plants to cover your thirty feet of trellis. You did not say the height of it, but we have assumed ten feet high; then you may plant either duplicates of these, or any you may prefer yourself, to fill the whole length nearly at once, and remove them as our selection fills up. Plant the *Laurels* as far from them as you can, and keep them within due bounds. Your soil will do, but have it trenched, and use great quantity of water the first season; all climbers like it, and stronger occasionally.

SPRING BULBS AND BEDDING PLANTS (M. B. B.).—In the second week in May, 1832, we called, among other places, at Eaton Hall in Cheshire, and at Knowsley, near Prescott; and there, at both places, we found gardeners removing immense quantities of Crocuses, Tulips, Hyacinths, and all the principal spring bulbs, from the flower to the reserve garden, to ripen their leaves, and keep the beds free for the summer crops. Since then we have ourselves practised that plan, and also that of potting all, or most of these bulbs, and removed them in their pots as soon as their beds are wanted; and, upon the whole, we have come to the conclusion that it is best and easiest not to pot any of them, but to remove them the first rainy or showery day after they are out of bloom, to take special care of the leaves, and to keep the ground well watered as long as the leaves kept green. We have also removed spring border flowers, as *Auriculas*, *Polyanthuses*, dwarf *Phloxes*, and such like, in the same way. Any good plant that flowers in the spring may, under this system, be made a bed of. The first flower-bed we ever saw was a bed of *Posies*, or *Polyanthuses*. About the 10th of May you can remove a bed of *Hyacinths*, &c., and plant it the same day with *Verbenas*, or *Calceolarias*, &c., filling in the spaces between the plants quite well with autumn-sown annuals. Next day it will look quite as well as with the *Hyacinths*, and next week it may be in full bloom, according to the kind of annual used.

DOUBLE GLAZING (Y. J. Bailey).—We made double-glazed windows for the fruit-room, when common glass was 1s. a foot, and we liked it much. A double-glazed frame would be as warm as a single-glazed one with double mats on—one inch, or less space will do between the glass. When we hear where glass is to be had at a penny per foot, as lately stated in our pages, we shall return to the subject.

ARCHES OVER WALKS (H.).—Your plan is most excellent, and the best we know of for the display of hardy climbers. A walk seventy yards long arched over, the arches “nine feet apart, and about seven or eight feet high,” will look extremely well. Let the centre of the arches be full eight feet above the walk. The standards to spring the arches from should be six-and-a-half to seven feet high; from these, and on both sides of the walk, arches should spring along the line of the walk, as well as across the walk. Let us earnestly advise you to adopt this suggestion. Then use duplicate plants along the whole line—that is, begin with 2 *Clematis montana*, one on the right, the other on the left hand; then 2 *Japan Honeysuckle*, 2 *Crimson Boursault* rose, 2 *Clematis cirrhosa*, to flower in February and March; 2 old *Double Musk* rose, or some good old *Noisette* to flower in the autumn; 2 *Aristolochia siphon*, for their broad, handsome leaves, and for the sake of variety; then 2 *Felicite Perpetuelle* rose, 2 *Sweet Clematis*, 2 *Laura Davoust* rose, 2 *Clematis Hendersonii*, 2 *Solanum jasminoides*. The following *Roses* are also eligible for your purpose:—*Queen of the Belgians*, *Rampant*, *Princess Marie*, and *Myrianthes*, *Rivers's Queen*, and *Wells's White*, or *Madame d'Arbly*. Try also *Tecoma*, or *Bignonia radicans major*. We would plant “annual and perennial creepers” as *auxiliaries*, but not till after the principals had one season's growth. Then we would try *Gloire de Rosamere* rose at the bottom of the rose pillars; *Clematis Sieboldi* and *purpurea*, with their kind; *Ecceumocarpus*, *Passion-flower*, *Lophospermum*, *Convolvulus major*, &c.

GOLDEN-CHAIN GERANIUMS (Rosa).—This, and the *Flower-of-the-day*, are best propagated in the spring, and should not be kept in pots during summer. In winter both of them will require little water, and to be grown in good turfy peat.

ERYTHRINA CHRISTA-GALLI (Ibid)—This is also best from spring cuttings, just like *Dahlias*, when the old plants make shoots three inches long. We do not usually recommend gardeners.

VINES (Rhydy Gros).—“Your vines have rooted from the very top of the stem under ground.” This is well; encourage such habit. For your insects, look to our back numbers for advice at the dressing used at pruning time. If they commence operations on the foliage in the ensuing

spring, see to fumigations, and the use of sulphur, as repeatedly advised in these pages. You must be moderate in your crop next year, suffering merely the strongest shoots to carry a bunch. The long-rod system is certainly manageable, but the close spur system for us, on the whole.

PEACHES (A. B. G.).—See an article on root-pruning in page 380 of last volume; this will meet your case. The large yellow *Ecnotheras*, *macrocarpa* and *missouriense*, are hardy; but the best way to propagate them is to pot a few old stools, and frame them, and propagate as *Dahlias*. They may be raised from seed, also, sown early in February. *Verbenas* will doubtless keep in the way you describe, but beware of confined damp, and use stout cuttings.

PEARS CRACKING (E. H. F.).—Your *Althorpe Crasanne* cracks through a capricious soil—that is to say, one suddenly liable to drought. If you cannot transplant, apply a top-dressing in the end of April, consisting of three parts manure, and one part adhesive loam, nearly six inches in thickness.

PEACH AND NECTARINE OVER-LUXURIANT (A Cheshire Rector).—Your main stem should have been pinched when it had grown nearly a foot; it is now established as a glutton, or robber. If the rest of the tree is disposed to grossness, root-prune immediately. Watch the shoots produced by your robbers next June, and pinch them as soon as six or eight inches long, repeating it in July in the next growth.

GREENHOUSE (Rev. R. Blackburn).—Your plan is good, and will succeed. This kind of house, with some trifling modifications, is much wanted by the amateur. We would have sashes at front, to slide horizontally in a groove, in order to reach the pots with facility, as also for ventilation purposes. Be sure you have capacious ventilators in back wall, the roof of course fixed. We would have four in yours, which is 17 feet 6 inches long, each half-a-yard long, and six inches wide, placed close to the top. You will also do well to provide a canvass shade, with a penthouse at back to receive it. You had better have four or five vines; when they are so far from the roof they have a tendency “to draw,” or run upwards, and any attempt to oppose this will be well-nigh futile. If you have no piping in front, you may readily obtain another shelf.

PLANTS FOR AUSTRALIA (J. T. W.).—As for fancy things, like florists' flowers, annuals, or any other kind of plant that you like or admire, you will find them just as useful in Australia as if you were only going with them from Inverness or Aberdeen to Exeter. All the bulbs of South Africa, and all the greenhouse bulbs from Washington, to the shores of Patagonia, do better in Australia than in Devonshire; so you may take out any bulb, root, plant, or seed you can lay your hands on; but we must not say where is the best place to buy anything. It is perfectly useless to ask us, or any other authority, what are the best plants for Australia. Whatever plants you like best are sure to be the best for you, either here or in Australia.

TREES BEFORE A HOUSE (Subscriber from No. 1).—Your “good lady” evinces better taste than many whom we could name, that are satisfied with such common things as *Lime-trees* before their doors, near London; and as you want them more for ornament than for screens, let her, by all means, have something handsome, and more aristocratic—say a couple of *Scarlet* or *Dwarf Horse-chestnuts*, the handsomest tree in England while in blossom. Ask for it by the name of *Æsculus rubicunda*; and those *Thorns* which make an equal display with either their flowers or fruit, and you can cut them to anything, if need be: *Crataegus aronia*, with splendid yellow, large haws, that are good to eat; *Crataegus orientalis*, the *Mespilus orientalis* of Tournfort, also with eatable fruit of a coral colour; *Crataegus tanacetifolia*, large yellow fruit. Then the *pink* and *scarlet-flowering Thorns*, and also the *double-flowering* varieties, white, pink, or scarlet. They are the sort of trees for “good ladies;” while *Lime-trees* are very useful for screening shops and butchers' stalls.

FLOWER-GARDEN PLAN (C. M.).—Your plan will be engraved, and will appear in our series, with such remarks as will suit your inquiries. Your proposal of festooning the roses towards the centre is a new and distinct feature, of which we much approve.

PRESERVING GRAPES (Susan).—We have kept grapes until after Christmas, by allowing them to remain on the vine, giving as much air as the weather permitted, to keep them dry. Plants may be grown well in the same house, for directly the leaves of the vine begin to turn yellow they may be stripped off. Grapes keep longer on the vine than anywhere else.

GLAZING GREENHOUSE (E. E.).—Do not let the glass lap over more than one-eighth of an inch. We prefer the laps not to be close.

TAXODIUM SEMPERVIRENS (D. P.).—There is some doubt about the identity of this tree, which is a native of North-West America, and that which is native of New Zealand. It is spoken of in the Horticultural Society's Journal as *Sequoia sempervirens*.

CRAMP IN COCHIN-CHINA FOWLS (Ibid).—We are told that they are liable to this disease, but we have never witnessed it in our own yard, where they have dry, warm shelters, and are liberally fed. Your diet for them is good, and their roosting-place warm. Have they a covered dry place to shelter and busk themselves in when it is wet weather?

VARIOUS.—Novice will see he has been attended to.

SHORT NOTICES (J. B. P., Dublin).—You will perceive we have not lost sight of your request. We try to meet the case of every reader, so far as we know his wants and wishes, and never look upon anything as a trouble.

RUSTIC SEATS AND GATES (An Old Subscriber).—We shall be glad if any one will send us drawings of such as they think ornamental. We will not lose sight of this. *Nettles* can only be destroyed by being constantly cut down, and by sowing salt over them very thickly.

NAMES OF PLANTS (M. A. L.).—No. 1, *Nigella hispanica*; No. 2, *Ulnus campestris*, variety *variegata alba*; No. 3, *Phlomis fruticosa*; No. 4 too much shrivelled to be detected. The Weeping Willow (*Salix Babylonica*) is a native of the Levant, and introduced to this country in 1730. The Weeping Ash is a variety of the common ash, propagated by grafting upon it.

INSECTS (Margate).—The insects sent as infesting old papers, closets, &c., are the *Plinius holosericus*, a species which has quite recently been imported from Russia in dried skins. It has spread with amazing rapidity. It feeds on dried animal remains.—J. O. W.

LONDON: Printed by HARRY WOOLDRIDGE, Winchester High-street, in the Parish of Saint Mary Calendar; and Published by WILLIAM SOMERVILLE ORR, at the Office, No. 2, Amen Corner, in the Parish of Christ Church, City of London.—October 7th, 1852.

WEEKLY CALENDAR.

M D	W D	OCTOBER 14—20, 1852.	WEATHER NEAR LONDON IN 1851.				Sun Rises.	Sun Sets.	Moon R. & S.	Moon's Age.	Clock bef. Sun.	Day of Year.
			Barometer.	Thermo.	Wind.	Rain in In.						
14	Th	Lady-bird hibernates.	29.928—29.841	62—44	W.	03	25 a. 6	7 a. 5	6 a. 7	1	14 1	288
15	F	Gossamer abundant.	29.430—29.336	56—32	W.	34	26	5	6 35	2	14 14	289
16	S	Martin last seen.	29.606—29.502	57—28	S.W.	—	28	3	7 7	3	14 26	290
17	SUN	18 SUNDAY AFTER TRINITY.	29.894—29.802	57—36	W.	—	30	1	7 49	4	14 38	291
18	M	ST. LUKE.	29.941—29.742	59—52	S.W.	01	32	IV	8 43	5	14 50	292
19	TU	Virginian Creeper leaves fall.	30.011—29.930	62—55	S.W.	01	33	57	9 44	6	15 0	293
20	W	Hen Chaffinches flock.	30.080—30.045	64—55	W.	—	35	55	10 53	7	15 10	294

METEOROLOGY OF THE WEEK.—At Chiswick, from observations during the last twenty-five years, the average highest and lowest temperatures of these days are 58.7° and 41.8° respectively. The greatest heat, 76°, occurred on the 14th in 1845; and the lowest cold, 24°, on the 15th in 1850. During the period 101 days were fine, and on 74 rain fell.

BRITISH WILD FLOWERS.

BERBERIDS.—BERBERIDACEÆ.

CHARACTERS OF THE ORDER.—Sepals 3, 4, 6, deciduous, in a double row, surrounded externally by petal-like scales. Petals below the seed-vessels, either equal to the sepals in number, and opposite to them, or twice as many, generally with an appendage at the base in the inside. Stamens equal in number to the petals, and opposite to them; anthers generally with two separate cells, opening elastically with a valve from the bottom to the top. Ovarium solitary, one-celled; style rather lateral; stigma globular. Fruit berried or capsular. Seeds attached to the bottom of the cell on one side, 1, 2, or 3; albumen between fleshy and horny; embryo straight in the axis. Shrubs or herbaceous perennial plants, for the most part smooth.

BERBERIS: Berberry; Barberry.

GENERIC CHARACTER.—Calyx below seed-vessel, of six spreading, reversed egg-shaped, concave, coloured, deciduous leaves; the three outer ones smallest. Petals six, opposite to the calyx, and not much longer, roundish-egg-shaped, concave, spreading, deciduous; the short claw of each bearing internally two oblong, more deeply coloured, probably, honey-bearing glands. Filaments linear, flattened, blunt, opposite to the petals, but shorter, attached to the base of each. Anthers of two separate lobes, on the opposite edges of the summit of the filament, each opening by a valve, from the bottom upwards. Germen oblong-oval. Style none. Stigma single, globular, broader than the germen, acutely bordered, permanent. Berry oblong, blunt, of one cell, pulpy, opening at the top. Seeds two or three, oblong, cylindrical, erect, attached by short stalks to the lower part of the cell.



BERBERIS VULGARIS: Barberry; *Pipperidge Bush.

Description.—It is a deciduous shrub attaining the height of eight or ten feet. Stems upright, branched, bark ash-coloured, slightly grooved, yellow inside, armed with sharp thorns, usually in threes. The first leaves are reversed egg-shaped, finely tooth-edged. Stipules terminating in a hair-like tooth. Stem-leaves alternate, the lowest slightly lobed, with spiny teeth. Secondary leaves in pairs, oblong, and saw-edged, and between the lower leaves and the thorns are

smaller leaves. Flowers towards the end of the branches, in drooping bunches, or racemes, with a bracte to each flower-stalk. Petals yellow, frequently saw-edged, with two orange-coloured nectaries at their base. Anthers roundish and yellow. Stigma greenish. Berries at first green, but when ripe a brilliant scarlet, cylindric-egg-shaped, rather bent, with a brown perforated projection at the end, and very acid. Seeds usually two, rarely three, loose in the berry, except slightly fastened to it at the bottom, oblong, thicker at the top, smooth, reddish, and hard.

There are many varieties, some being without seeds; others with white, yellow, purple, or black berries.

Places where found.—In hedges, and on bushy, chalky-soiled hills.

Time of flowering.—May and June.

History.—Its British name is the Pipridge, or Pipperidge; the Botanical one, and its corruption, Barberry, being borrowed from the Arabic. When the anthers are thoroughly ripe, if the base of the filament be irritated with a pin, or a bristle, the stamen rises with a sudden spring and strikes the anther against the summit of the pistil, affording a remarkable instance of one of the means used to perform the important office of impregnation. This singular vitality of fibre, which we denominate irritability, and which is particularly apparent in such plants as are called sensitive, excited the attention of that very ingenious experimentalist Kölreuter, who observes that the cells of the anthers do not split open lengthways, but that the outer coat detaches itself along the edges of the partition, which separates the two cells, and raising itself up with the greater portion of the pollen adhering to the inner surface, finally faces towards the stigma; having the inner surface that fronts the stigma covered with pollen. It is by this beautiful expedient that nature has so completely succeeded in her object of fecundation by the emission of pollen; for by this mode of opening of the anthers the stamens have gained so much in length, that they are enabled to reach with precision the stigma on which they are to discharge their contents; had the cells opened in the usual way, the stamens would have been too short for their intended functions. And here we may well exclaim with Cowley,

“If we could open and inbend our eye,
We all, like Moses, should espy,
Ev'n in a bush, the radiant Deity.”

When a stamen has gone through this movement, it draws the petal to the base of which it is fixed a little toward itself, and this is the reason why, when we have suddenly stimulated all the stamens of a flower that was before nearly expanded, we see it half closed again. The anthers are insensible to stimulus; the filaments evince most irritability nearest their base. The phenomenon may be fully induced by a burning lens; and when the flowers are electrified, and sparks are drawn from them by the approach of a metallic body, the stamens immediately spring toward the pistil. If it could happen that during the season of bloom the flowers were to remain uninfluenced by adventitious stimulus, the stamens would continue extended at their wonted distance from the pistil, and no fecundation could take place. But let us see the means adopted by Divine Wisdom for insuring the fecundation of this useful vegetable. Each petal has near its base two oblong honey-bearing glands. Between every two of these glands a stamen is placed, so that whenever an insect (of which abundance present themselves in the course of a day, beetles, flies, bees, and wasps, seeking

their own food), attempts to extract the honey exuded by the glands, it must touch, especially the lower and most irritable part of the filament, upon which this organ immediately springs up and proceeds to cover with its prolific dust the upper part of the pistil. A process nearly analogous may be observed in *Aristolochia*, *Orchis bifolia*, and some few other indigenous instances: caprification has been long known to afford remarkable exemplification among exotics.

The leaves are gratefully acid. The flowers are offensive to the smell, when near, but at a proper distance their odour is extremely fine. Dishes for the table are often garnished with bunches of the ripe berries. They are so very acid that birds will not eat them, but boiled with sugar they form a most agreeable rob or jelly. They are used likewise as a dry sweetmeat, and in sugar plums. An infusion of the bark in white wine is purgative. The roots boiled in lye, dye wool yellow. In Poland leather is dyed of a most beautiful yellow with the bark of the root. The inner bark of the stem dyes linen a fine yellow, with the assistance of alum.

An opinion is entertained by many who deserve attention,

THE EDITOR OF THE COTTAGE GARDENER, AS ONE OF THE HONORARY SECRETARIES OF THE WINCHESTER AND SOUTHERN COUNTIES SOCIETY FOR THE ENCOURAGEMENT OF POULTRY, will be greatly obliged by subscriptions being forwarded to him. Every subscriber of five shillings or upwards, thereby becomes a member, and every one wishing to become a member is requested to forward his or her subscription immediately. This is desirable, because the amount of prizes at the Society's first Exhibition, to be held on or before the first of December next, will be increased in proportion to the Society's funds.

The following excellent classification, first arranged by the Birmingham Society, is that also adopted by THE WINCHESTER AND SOUTHERN COUNTIES SOCIETY.

<i>Spanish.</i>	<i>Polands</i> ; black with white crests.
<i>Dorking</i> ; single-combed.	<i>Polands</i> ; golden, with ruffs or beards.
<i>Dorking</i> ; double or rose-combed.	<i>Polands</i> ; golden, without ruffs or beards.
<i>Dorking</i> ; white.	<i>Polands</i> ; silver, with ruffs or beards.
<i>Cochin-China</i> ; cinnamon and buff.	<i>Polands</i> ; silver, without ruffs or beards.
<i>Cochin-China</i> ; brown, and partridge-feathered.	<i>Any other distinct breed.</i>
<i>Cochin-China</i> ; white.	<i>Bantams</i> ; gold-laced.
<i>Malay.</i>	<i>Bantams</i> ; silver-laced.
<i>Game</i> ; white and piles.	<i>Bantams</i> ; white.
<i>Game</i> ; black-breasted, and other reds.	<i>Bantams</i> ; black.
<i>Game</i> ; blacks, and brassy-winged, except greys.	<i>Bantams</i> ; any other variety.
<i>Game</i> ; duck-wings, and other greys and blues.	<i>Pigeons.</i>
<i>Golden-pencilled Hamburg.</i>	<i>Geese.</i>
<i>Golden-spangled Hamburg.</i>	<i>Ducks.</i>
<i>Silver-pencilled Hamburg.</i>	<i>Turkeys.</i>
<i>Silver-spangled Hamburg.</i>	<i>Guinea Fowl.</i>

SIR,—Take them as a body, gardeners are very droll dogs. They have the bump of obstinacy, and the bump of self-esteem. Gall and Spurzheim tell us that these bumps may be exchanged for other and better bumps, provided the party owning them will read or listen to advice. In plain English, if a conceited man leaves off being conceited, the bump of conceit or self-esteem would subside, and give place to the bump of inquisitiveness.

What strides the gardeners in moderate establishments would make, if they could once succeed in being desirous to learn, in place of having an idea that they know more than any body else.

Since I first had a gardener, now some twenty-five years ago, every one who has lived with me has had this unfortunate "bump of conceit," which has always been a great

sustained as they are by some facts, that the Barberry causes wheat growing near to it to be attacked by the mildew. On the other hand, there are many evidences that wheat may be grown in its vicinity without being so affected. It is quite certain that the yellow parasitical fungus found on the leaves of the Barberry, is not the fungus that is the cause of the mildew. They are not only different species, but of different genera; that on the Barberry being *Æcidium Berberidis*, and that on the wheat is *Puccinia graminis*.

The peculiar constituent of the bark of the Barberry, which renders it not only a powerful tonic in medicine, but useful as a dye, has been named *Berberite*. It was first obtained pure by M. Buchner, in 1835. He administered it to some of his patients, in doses of ten grains, and found it a powerful tonic. Berberite answers very well as a dye-stuff, giving a fixed yellow colour without any mordant. Chloride of tin improves the colour. When the cloth is previously impregnated with sulphate of copper, a beautiful greenish-yellow colour is obtained. With nut-galls the colour is yellowish-brown. (*Lindley. Smith. Martyn. Withering. Thomson.*)

hindrance to him in his work, and always, in my experience, ended in a change. My present gardener is as obstinate a dog as you can well imagine. I read very regularly and very carefully, week by week, THE COTTAGE GARDENER, and mark every thing I think worth notice, for my man, and at the end of the week, when I go round the garden with him to see what has been done, and what will require to be done, I hand him over your invaluable little work, offering to him some remark upon the various items which have been noted for his perusal. I always get the same answer—

"It's all very well for them gents to write, but I know a great deal more than they do. They only put things in their paper to mislead, and then of course when our master reads them, he sucks it all in for truth, and that's the way so many poor gardeners are turned adrift."

In vain I have told him, that Mr. Beaton, Mr. Errington, Mr. Appleby, Mr. Fish, and all the other parties who write in THE COTTAGE GARDENER, do so with a sincere desire not to mislead, but to instruct and encourage both the old and the young. I have even myself taken the trouble to follow out, under my own superintendence, some hints thrown out by your able contributors. Success has always attended my efforts, but

"A man convinced against his will,
Remains of the same opinion still."

And so it is with my man; and yet the man is industrious, but his industry is very often lost for want of that bump of inquisitiveness; and nothing, I believe, but a new race of men, will ever correct the evils and heart-burnings which must arise between master and man.

The life of a common working gardener is, I am quite aware, against an increase of knowledge. He labours from Monday morning to Saturday night, and has only Sunday to refresh and recruit his strength and ideas. I have tried a different system; I give my man four set holidays in the year. I send him on those days either to Kew, Chiswick, Regent's Park, or Rosherville Gardens, pay all his expenses, and tell him to pick up some new ideas, and come back as lively as a lark.

Last year, I sent him and his wife to the Crystal Palace, and desired him, as a matter of course, to look at all the new garden things there, with a view to his improvement, and my benefit. When he came home, I asked him how he liked the place, and what he saw, his answer was—"Nothing new of note in the garden line." And the only things he thought well of, were the warlike weapons! The man is young (only 32), but his ideas are fixed, and nothing seems to stir him up; and if I were to change him for another, I might, by trying to jump out of the frying-pan, just jump into the fire.

Now, what I want you to do, Mr. Editor, is to write pretty regularly some paper on this sad subject, for I know nothing more disheartening to a gentleman, than continually seeing new faces, without getting even a change of ideas.

If I were not engaged all day, and every day, in business, I would only have a good, honest, willing, steady, and hard-working labourer, rather than a man calling himself a gardener. Plain directions, and a little common sense,

would do much, for nature is always ready to give plenty, if due diligence is used.

Once more, therefore, good Mr. Editor, have the goodness to do your best to improve this obstinate race of beings, you would add to their happiness, and to our comfort as masters, and you would be raising your journal high in the scale of usefulness.

A CITY FRIAR.

SUCH is the letter we have just received from a gentleman whom we know to be a man of sterling sense, and an indulgent master, but we are glad in the conviction that there are not many cases similar to his own, for we have little power to help the employers of such gardeners as our friend endures. We cannot undertake the office of censor of gardeners, any more than we can undertake to educate them. All that we profess to do, is to prepare weekly information appropriate to the season, conformably to the best gardening knowledge of our time, and to answer such questions as are addressed to us.

That information, and the answers to such questions, are given by some of the best practical gardeners of the day; and we can state, without any possibility of contradiction, that whoever has adopted their recommendations carefully, never failed in obtaining his object. Now, if a gardener, who has had none of the advantages which are possessed by our departmental writers, thinks that he knows as much as they do, and spurns at the information they can give, we can only pity him as a man that of all others is most hopeless of being improved, for he is not only ignorant, but is ignorant of his ignorance. Such a man, perhaps, will be surprised to hear, that there is a correspondence continually being carried on between the most skilful of British gardeners, who seek from each other advice, and suggestions, and information, when they are carrying out new plans, and when they encounter difficulties. Such men come also to THE COTTAGE GARDENER'S pages, and one of the most distinguished of them has said that he never took up one of our numbers without benefiting by some of its information.

We claim no especial merit for this, because from the worst of publications some instruction must be gleaned. Above all, we have not the presumption to attempt to instruct gardeners. We address ourselves to the amateur, and we advise him, as in the case before us, never to attempt to *teach* his gardener. There are always modes of conveying our wishes, without making it conspicuous that a man does not know his business, and if he carried our wishes into effect, we should never enquire whence he derived the necessary knowledge, or what means he adopted. He may have plans of his own, and whilst we are quite alive to what results the master has a right to require, we are quite as sensible that as the responsibility of failure rests upon the gardener, the means to be adopted should be left to him. Mrs. Ashton Smythe, it is said, requires grapes in the desert every day of the year, and Mr. Sanders, the gardener at Tidworth, regularly supplies the demand, but his employer never thinks of dictating how it shall be done. If however, Mr. Sanders did not know how to effect such a succession, and refused to be instructed

how Mr. Fleming, of Trentham, accomplishes the same object, then we should say he failed in his duty, and was unworthy of his position.

COVENT GARDEN.

I MUST not forget that in my last paper I promised to refer more at length this week to several subjects that were only alluded to in the report of last. And of these, the first we shall notice are those varieties of fruits which are most likely to be soonest over, and which are not likely to come under our observations again this season. The *Hessle Pear*, which we referred to last week, and which we observed is not "Hazel," as written by Lindley, nor "Hessel," as in the Horticultural Society's Catalogue, is a variety which was first discovered at the village of Hessle, near Hull, in Yorkshire. It does not rank as a first-rate pear, nor is it to be compared to many others of the same season; but being an immense bearer, and a respectable-looking article for the popular eye, it is admirably adapted for market-gardeners and orchardists. The tree is of very graceful habit, having slender pendulous shoots, of a very dark-purplish-black colour, and may easily be distinguished from every other variety by its characteristic appearance. *Louise d'Avranches*, and not "Louise Bonne de Jersey," as it is now erroneously called, is one of the very best and most delicious of our autumn desert pears. There have been a few of them in the market during the week, but ere our next report is written their season will be over. It is generally stated, by writers on pomology, that the origin of this variety is unknown; and having been introduced to this country from Jersey under the name of "Louise Bonne," it was, to distinguish it from the old Louise Bonne of Dubamel, called "Louise Bonne of Jersey." But its proper name is *Louise d'Avranches*; and all who value correctness of nomenclature, may take my authority, if they think it worth taking, for stating that it was raised by a M. Longueval, of Avranches, and the original tree is still in existence in the garden Rue St. Germain, and now in the possession of M. Le Clerc.

Of APPLES there has been a good supply during the week, and the demand has been very brisk. Sorts, which the week previously made 2s. 6d. and 3s. per bushel, have last week been sold for 4s. and 5s. And who do our readers imagine is the cause of this great and sudden rise? The Michaelmas goose. "I could a sold twice as many as I had, sir, if I could a got 'em," said a salesman to me. "I never see things go off as they did, never, all *my* life." The sorts which were in the market were—*Emperor Alexander*, *Alfriston*, *Hanwell Souring*, *Golden* and *Winter Pearmain*, *Scarlet Pearmain*, *Nonsuch*, and many lots of mixed varieties.

The PEARS which have been most plentiful, are *Bishop's Thumb*, but they were generally very small, and inferior in quality, their flavour being styptic. *Swan's Eggs* have made their appearance, but only to a small extent; there being only a few bushels of them offered. Everybody knows the *Old Swan's Egg*, as one

of the most highly and peculiarly-flavoured of our old English varieties. The *Brown Beurré* is also among the arrivals of the week, and is now just coming into perfection. Many of our readers may not know, and a great many have never heard of this fine old pear. It is a French variety, which has been held in high estimation by the horticulturists, both of this country and the Continent for the last two centuries; but as it requires the protection of a wall to bring it to perfection, it is not so generally cultivated, nor so widely known as it would have been had it been better adapted to general cultivation in this country. The prices which pears have made last week are also considerably in advance of the former. The cold weather is now driving our London population from their summer to their winter quarters, and consequently the demand and consumption becomes every day greater.

There is nothing new in the way of PLUMS from what was recorded last week, except a few *Reine Claude Violette* or *Purple Gage*, a fruit, which some of our readers will perhaps be astonished to find me say, I prefer to the green gage. Whether grown upon a wall, or as a standard in a suitable situation, and allowed to hang till it is "dead-ripe," that is, till it begins to shrivel, it is one of the most delicious sweetmeats which the most delicate palate could desire; but it must not be confounded with the "blue gage," a very different and inferior variety.

There have been some very fine GRAPES exhibited during the week, and particularly a few bunches of large well-grown *Canon Hall Muscats*, which were sold at 5s. and 6s. per pound. The *Black Hamburgs* continue at last week's quotations.

CUCUMBERS have been very plentiful, and some of them very good and cheap. I observed a lot varying in length from twelve to eighteen inches, from 2d. to 6d., and 9d. each. FILBERTS plentiful, at 9d. per pound. TOMATOES, 4s. to 5s. per half-sieve, or 8d. per punnet, containing eight or nine large ones. CAPSICUMS, long red, 6d. per dozen. MUSHROOMS are very plentiful and very large, and fetched from 3s. 6d. to 5s. per bushel.

CUT FLOWERS are, of course, not so plentiful now as they were earlier in the season; they consist of both in-and-out-door plants. As an illustration, I shall give the following constitution of a large and handsome bouquet:—*Double White Camellia*, *Double Chinese Primroses*, *Geraniums*, *Scarlet Geraniums*, *Azalea indica alba*, *Mignonne*, *Heliotrope*, *Gardenia*, *Verbenas*, *Pinks*, *Saffron Rose*, and fringed round the outside with leaves of the *Oak-leaved Geranium*. Of the common kinds there are lots of *Dahlias*, *China Asters*, *French and African Mari-golds*, *Fuchsias*, &c.

Again we must leave much of what we should like to have noticed till another week. H.

The following is a list of the *Horticultural and Poultry Shows* of which we are at present aware. We shall be obliged by any of our readers sending us ad-

ditions to the list, and giving the address of the Secretaries.

HORTICULTURAL SHOWS.

- BURY ST. EDMUNDS, Nov. 26 (Chrysanthemums). (Sec. G. P. Clay, Esq.)
 CALEDONIAN (Inverleith Row), Edinburgh, Dec. 2.
 HAMPSHIRE, Nov. 18 (Winchester). (Sec. Rev. F. Wickham, Winchester.)
 LONDON FLORICULTURAL (Exeter Hall, Strand), Nov. 9+, 23, Dec. 14+.
 NORTH LONDON, Nov. 23, Chrysanthemum.
 SOUTH LONDON (ROYAL), Oct. 14+, Nov. 11+, Dec. 9+, 16.

POULTRY SHOWS.

- BIRMINGHAM AND MIDLAND COUNTIES, 14th, 15th, 16th, and 17th December.
 BRISTOL AGRICULTURAL, December 7th, 8th, and 9th. (Sec. James Marmont.)
 CORNWALL (PENZANCE), about a week after the Birmingham. (Secs. Rev. W. W. Wingfield, Gulval Vicarage, and E. H. Rodd, Esq.)
 DORCHESTER, Nov. 18th. (Sec., G. J. Andrews, Esq., Dorchester.)

† For seedlings only.

PINE-CULTURE—HAMILTONIAN MODE.

(Continued from page 6.)

In the last paper the subject was brought up to the matter of *glass*; heating being merely pointed at. We here resume it; and having stated Mr. Hamilton's amount of piping for a house to fruit one hundred plants, we may offer a few observations. It will be remembered that Mr. Hamilton uses a flow and a return pipe all round the pit, with the exception of the end farthest from the boiler, and these exclusively to warm the atmosphere of the house. Each five-feet bed, too, has its flow and return pipe; and if we understand Mr. Hamilton's observations correctly, the flow and return in each bed are totally unconnected with each other, or with the flow and return round the exterior. It may also be observed, that the latter is in two divisions,—the one passing along the south side, and the other along the north, unconnected; a flow and return to each; the only bond of connection being the boiler, or, rather, the iron pan before described, where it would appear all the pipes meet. The two delivery pipes for the atmosphere proceed out of the two sides of this pan, near to and parallel with the end of the house, and the two delivery pipes for the bottom-heat proceed from the front of the pan, and fall at once into a similar parallel, and thence turning right and left into the chambers, the return pipes being, of course, beneath them. It will be seen that by this arrangement there must, perforce, be a great preponderance of heat at the boiler end, which, indeed, is the case in most houses, and so far generally leaves in the mind an idea of incompleteness—something to be desired. We stay not here to offer suggestions as to the possibility of improvements; space will not permit; but merely point, as we proceed, to matters deserving farther consideration, and leave it to the mind of the ingenious reader to examine such portions of the subject.

VENTILATION.—Mr. Hamilton, in his descriptive account, has said nothing on this head; not, however, because it is unimportant. We must here offer our ideas. In all ventilation, as connected with horticultural structures, it is a practice founded on well-known principles, to provide both outlet for the heated air—presumed to be of a depraved character—and inlet of fresh or cool air, of course, pure; these at distinct levels. We need scarcely point to the fact, that such practice is based upon the well-known rarefaction of air by heat, whereby warm particles have a constant tendency to

ascend, and the cooler as strict a tendency to rush in and supply their place. These facts are so well known to our readers that we merely point to them. Of course, under such circumstances, the highest level possible naturally seems the most eligible for the outlet, and the lowest for the inlet. The apex of a span-roof is, indeed, the very point where the greatest accumulation takes place, and here we at once suggest some ventilators. This position in such a house is tolerably fortunate in another respect; beneath it is the walk or passage, and here the operator can work such ventilators with facility, by a rope or otherwise. In all cases, we would have the escapes of liberal dimensions. It has been, and still is a practice with many, to have sliding roof-lights, but this is bad practice, involving much breakage of glass and inconvenience; a sufficient ventilation may always be accomplished by the ventilators here alluded to. There are many ways of constructing, fixing, and working these things, and we may merely observe, that any mode which will permit them to be worked with facility, and so fitted as to be capable of graduation and of excluding the rain and wind, will suffice. In a house fifty feet long, and of the character before described, we should have apertures of this kind about every ten feet, presenting an area when wide-open of about half-a-yard in length, by a foot in width. It is seldom that they would be required wide-open; nevertheless, it is well to be provided for contingencies, especially if unprovided with a shade. It must here be understood, that we consider this the minimum amount of escape.

And now for the inlet, or admission of fresh air at as low a level as is consistent with other regulations. Modern practice recognises the propriety of heating fresh air on its entrance to the interior of the house, and there is little doubt that it is really expedient to do so. To this end, the heating apparatus in modern hot-houses is so arranged, that in general one or two pipes are so placed as to receive the cold air at its entrance; that is to say, the position of the piping is made to bear a relation to the front ventilators. In some cases, front sashes are used, and these are made to slide or to swing outward on hinges; but, it must be remembered, that there is no absolute necessity for front sashes in pine-culture. Be that as it may, there is sure to arise a necessity for piping at the front of the house, and advantage should be taken of this, to have at least one pipe just above the floor level, and the ventilators for admitting fresh air just opposite that pipe. We think it a very good arrangement where two pipes, a flow and a return, are wanted in front, so to arrange them, and the boiler level, as that the lower or return pipe may rest on the floor line. This pipe we would have partly enclosed in a trench, say half its depth, and this trench made waterproof, and of some eight or ten inches in width, might have a tap at one end, communicating with a cistern or reservoir, so as to fill the trench with water as often as necessary, whilst, at the other end, should be another tap, or plug, entering a drain, so as that the water at any time could be run off speedily. This we consider a most excellent plan, and not a whit the worse from its extreme simplicity; it is what we have formerly termed "a pipe in a ditch." The apertures for the admission of fresh air should, as before observed, be opposite the surface of this trench, and the air would pass through the body of the house or pit duly attempered with heat and moisture. One thing is very desirable, to which we before alluded, viz., the propriety of being able to graduate the front air according to circumstances.

Thus much as to the ventilation; and before quitting the subject, we must beg to recommend a canvass shade to all houses with a southern slope, especially if large panes of sheet-glass be used. This should, by all means, be fixed to work on a roller, after the manner of the

orchid-houses about the Metropolis. Whatever people may say about the pine enjoying plenty of solar-light, which is, doubtless, the case when in a very healthy condition at the root; still, there are a few hours daily, in hot periods, when such shade is of immense benefit, if only in preventing a too rapid diminution of air-moisture. But a judicious shading accomplishes much more, and the preservation of their beautiful green-colour, together with that milky-green tint, for which healthy pines are notorious, is an object connected not only with appearance, but with health itself.

It will be seen that Mr. Hamilton advocates heating by hot-water; and, indeed, when properly fitted, we see nothing more to be desired. As to the old smoke-flue for pine-culture, nobody ever dreams of it in these days. We do not say that pines cannot be grown by such a mode of heating; they assuredly can, and well too, if needs be; but what we must affirm is, that it involves more expense in the end, and more uncertainty; and is, of necessity, nearly as great a consumer, as producer of atmospheric moisture; without a liberal supply of which, it matters not what the mode of culture may be. Whether piping or flues be used, a due provision must be made for *air-moisture*. It is a very common practice to have flue-covers in the form of a sunken panel, such should be three inches in depth; for piping, metallic trays of a saddle-form, may be placed on the flow-pipe, or the pipes may be obtained with flanges, all of a piece; and these, too, must be made to hold a liberal amount of water. In all three cases, a permanent reservoir should be established, however supplied. Those who have a fall of water, and require much for other purposes, would do well to use a "hydraulic ram," which is, indeed, one of the most valuable adjunct a garden establishment can possess. We have had one in work here for some thirty years, and this constantly supplies the mansion, laundry, stables, gardens, farm-buildings, and, indeed, the whole premises.

Before quitting the heating portion of the subject, we must beg to advert to another point or two. In the first place, our advice is, be sure you have a liberal amount of *piping*; that is to say, secure heat enough and to spare. We would have an apparatus which would guarantee us 70° in winter, when the out-doors thermometer indicated 12° or 15° of frost. Some persons may think this unnecessary, but they may be assured that under-heating is a false economy—a sad mistake. When the house is short of heating surface, and hard weather occurs, there is a continual temptation to stir the fires, and the owner may rest assured that every stir costs money. We would so arrange matters, as that little stirring was requisite, and that two good fire-dressings in the twenty-four hours should, if possible, suffice; all the rest should be regulated by the ash-pit door. In these cases, care should be taken to secure a capacious grate that will hold abundance of fuel. Those who have to "pay the piper," need not be alarmed at these things; we are not going to advocate a greater consumption of fuel than other folks.

We know of a Rogers's conical-boiler, one of the smaller size, that has been working for some half-dozen years, and we will engage that it has constantly consumed nearly twenty per cent. more fuel than a capacious one would have done. The hopper for fuel is so small, that it requires feeding every two to three hours, and if not waited on as late as eleven o'clock on a winter's night, it is almost sure to go out. Here, then, is a case in point; the working such an apparatus as this for half-a-dozen years, would go far to cure any one of a predilection for small furnaces.

As to the *boiler*, we care little about that; too much importance has been laid on these things. The best we have ever had to deal with is a "Burbidge," and from the firm of Burbidge and Healy, in Fleet-street. This

is really so complete, as to leave nothing to be desired. It is on the reverberating principle; and the ash-pit doors, which slide on a round bar of iron, give the most complete command over the apparatus.

One thing, as connected with the heating, we had almost forgotten to name, and that is, the propriety of having sliders or openings in the walls of the chamber that contains the pipes for bottom-heat; these, when the bottom warmth proves too strong, may be opened for awhile, and the surplus heat discharged into the air of the house. By such means, the bottom-heat and air-heat may be made "to play into each others hands." Having now disposed of heating matters, structure, &c., we shall, in a future number, take up cultural details.

R. ERRINGTON.

BEDDING, HERBACEOUS, AND ROCK PLANTS.

The prettiest plant for a flower-garden, that I have seen this season, and one that is very little known out of London, is called *Gaura Lindheimeri*, named after some German of the name of Lindheimer, and is pronounced as if written Lyndhymer, with the accent on the *ei*. For those who are looking out for good herbaceous plants, here is one of the gayest, and although not yet proved, I am quite sure it will make as showy a bed as any plant we now possess of a light colour. It is now (2nd October) beautifully in bloom in my own experimental border, and I think we can always rely on it from early in June to the end of September. It will seed as freely as the poppy, and it is perfectly hardy. Here, then, is a treasure, a novelty, and a gay flower to the bargain. I received my plant of it from the Horticultural Society. Fellows of the Society are entitled, by long usage, to any little thing that can be spared from their garden; and many persons join the Society, not for encouraging the growth of cabbages, but altogether for what stray plants they can call for from the garden; and some members do call for things most outrageously, and say all sorts of things if their demands are not complied with by return of post or train; but since 1830, I never heard of any complaints of one member being favoured more than another, in this respect. On the other hand, many of the members think it below their dignity to ask for anything from the Society, and would rather see part of their funds expended in keeping a collector or two, in distant parts, searching for new plants. At present, the Society has no one "out" on such a mission, excepting the ninth-part-of-a-man who went out some time since to Oregon. My plant of *Gaura Lindheimeri* is not likely to ripen seeds this year, having been removed at the wrong time. Whether it is in the nurseries or not I have not heard; but there are several large plants of it in the garden of the Society, in the American ground, in patches, and the idea of making it into beds occurred to me the moment I saw it. The plants of it at Chiswick are two or three years old, and between two and three feet high; the upper half being covered with flowers in the terminal-spike fashion, every branch ending in a spike of flowers. The plant grows in a dense mass; the spike begins to flower from the bottom, and before it has done flowering at the top, some of the seeds are ripe on the lower part, just as the *Clarkias* and *Godetias* do. The plant forms a section of the same order (Onagraceae), as the *Clarkias*, *Enocheras*, *Fuchsias*, and the like. The flowers are pure white, starchy, and as large again as those of *Jasminum grandiflorum*, and the calyx is larger than usual, and of a deep pinkish-red colour, throwing a shade of French-white on the flowers as they tremble in the air; altogether very pretty and pleasing. If we go right with this new bedder, we need not have it above eighteen

or twenty inches high, or about the same size as a good bed of *Salvia chamædrioides*, and this is the only plant with which I can compare its style of growth and flowering, only that this *Gaura* will produce three spikes, or three times as many flowers as the *Salvia*.

One may be excused for erring in first experimenting on a plant for a new purpose. But the following is the way I would try our present subject. Sow seeds of it the first week in March, and as soon as the seedlings were up, give them as much air as to *Calceolaria* seedlings. Pot them first into store pots, and afterwards into single pots of the smaller size, and by the end of April they would be fit to plant out in a nursery-bed, or border. Here I would let them remain till about Midsummer, then I would plant them out into the flower-garden, where a bed of annuals were beginning to fade. When the white and red *Clarkias* are sown in the second week in April, they generally begin to look seedy by the last week in July, and this *Gaura Lindheimeri* would be an excellent substitute for a bed of white *Clarkias* in a regular arrangement of colours. Seedlings of the *Gaura* would be coming into bloom by that time, or if they were in full bloom, they would remove from the nursery-bed with no harm. Some persons would prefer keeping them in pots all the while, but that is too extravagant for half the world, because of so much watering, and too slovenly for any good gardener, for unless a gardener can remove nine-tenths of all his annuals, without hurt, from a nursery to a flower-bed, any time before they are in bloom, why, he may as well bundle up and be off to "the diggings." The second year there will be no difficulty in having the bed of *Gaura*, by treating the plant as a biennial. Sow it towards the middle or end of May, in the open ground, in the reserve garden, and if it should throw up for flower in the autumn, let the flower-stalks be cut off as fast as they appear. It will then be in good order to plant out next spring where it is to flower. After that, old plants of it may be divided every autumn or spring, so that the plants do not get too high for a bed, or, perhaps, seedling plants will be found preferable.

Salvia coccinea.—I saw plants of this old and long-forgotten *Salvia* in the same collection, and it is well worth being saved and propagated for bedding-out. The only other one of the genus which will remind gardeners of the aspect of this *Salvia*, is one that was common twenty years ago, and called *Pseudo coccinea*. But this old one does not appear to be so strong, and is a more close and freer bloomer.

I also saw a variety of bedding *Geranium*, related to the *Golden Chain*, but a much stronger, and a larger-leaved kind, with the yellow on the leaves paler. Where the *Golden Chain* succeeds, as it does at Shrubland Park, this will never be a rival to it, but where the soil does not suit the *Golden Chain*, this will be a good, indeed the best, substitute for it. They had no particular name to it. *Punch* was the best scarlet in the flower-beds here, and it stood the heavy rains better than *Tom Thumb*. There was also a fine large bed of the *Salmon Geranium*, and *Lady Middleton* was a great favourite, and preferred before either *Cherry Cheek* or *Judy*. There was a large bed of a neutral tint, made of *Verbena trifida*, a close grower, and greyish flowers, which are very sweet, and the kind is well worth growing, not for bedding, but for cut flowers for nosegays, to be used as flowers of the Heliotrope. The best new *Verbena* I have seen this year, for a distinct bed, was at Mr. Jackson's nursery, next door to me, it would make the best pink bed of all I have seen; the flower is a bright reddish-pink, with a large white eye; the plant was in a pot, but the habit appeared to be well suited for a bed, and the name is of foreign accent, *Madame Comonissam*, or some such word, for the tally was not very clearly written.

HERBACEOUS PLANTS.

The very best autumn-flowering plant of this description that I saw in the Society's garden, was *Funkia grandiflora alba*. In my younger days, *Funkias* went by the name of *Hemerocallis*, or Day Lily, and this white one, though not very new, is the very best of the family, and is, indeed, a conspicuous plant, well worth having; and flowering so late in the season, makes it still more desirable. There are two plants not altogether herbaceous, or shrubby, but something between the two as they stood in the borders; one is *Clematis tubulosa*, and the other my own great favourite, *Indigofera decora*. Both have received medals as green-house plants, but they are sufficiently hardy about London to stand out in the borders, and from what I know of them, both prefer a peat border. The *Clematis* stood as a thick bush, twenty inches or two feet high, and well covered with large light-blue flowers. I saw it in two or three other places this season, where it was not nearly so good, but the nature of the soil made all the difference. *Gentiana pneumonanthe* was in fine bloom in the American-garden, and there were several other species of the Gentian, all nice flowers for a mixed border; and there are several little shrubs, or half shrubs, that are equally suitable for such a place, and foremost among them is the old-fashioned *Comptonia asplenifolia*, named after Bishop Compton, the greatest patron of gardening and botany in his day. It is a North American plant, doing better in peat than any other way, with leaves as pretty as those of a fern; and *Clethra alnifolia*, another little American plant, requiring a damp peat-border, and seldom seen out of nurseries. I saw them both in the mixed borders at Chiswick, and I never saw them so much in character before. In the same borders were large patches of the scarce *Azalea procumbens*, which one hardly ever sees in these days out of botanic gardens; this is a native of the Grampian range, in Scotland, and it is said that at one time its place of growth was only known to the Messrs. Brown, of the Kinoul Nursery, at Perth, who made a better market of it than of the *Double Scotch Rose*, which was first obtained by them in that nursery, and I never saw it more flourishing than on this occasion, and I recommend it and *Epigaea repens*, another scarce plant, as pet plants for the American borders. A plant of the *Lilium giganteum*, of India, one of the most stately of all the true lilies, has been planted out here in the new American garden, and it looks as if it would do out-of-doors with us; and if so, it will be a match some day for the Pampas grass (*Gynerium argenteum*), which is not far from it in the same garden, and which I hope the Messrs. Dickson, of Chester, will be able to seed, and when Mr. Appleby calls there again, he would bring us up a large batch of the seedlings; indeed, it would be worth while to send out to Mr. Tweedie for a peck or two of the seeds of this royal grass. Mr. Tweedie was the collector who first sent it to the Glasnevin Botanic Garden, in Dublin; and as Mr. Appleby tells us (vol. viii., p. 414), that "unfortunately the Messrs. Dickson have not been able as yet to increase it," writing to Mr. Tweedie seems now the only chance we have of getting a stock of it for supplying the universal demand that is sure to be made for it wherever THE COTTAGE GARDENER is read. Does our friend Mr. B., of Philadelphia, know a correspondent in the south, who could send him a supply of the seeds? Let him and Mr. Low, of Clapton, who has dealt largely with Mr. Tweedie, run a race for this grass.

ROCK PLANT.

But grass or no grass, I must not run away from my little pet plants, till I make known the *best rock plant*, in England or America either; it is called *Polygonum vacciniifolium*. I saw it both at the Society's Garden, and at Kew, and there can be no mistake about it,

although some of us are disappointed at not seeing the flowers come out so gay and brilliant as they are given by Dr. Royle, in his "Illustrations of the Plants of India," where the colour of the flower and the spikes is a deep rose, but with us they put you more in mind of a red brick than of a rose; nevertheless, all the cottage gardeners in the kingdom must get hold of it. It grows as close as a carpet, and runs away "like anything," as Sam Slick would say. It only grows a few inches high, but it flowers all over, like a corn-field, in close spikes, three or four inches long, and that too all through the autumn, until the frost puts a stop to it. According to Dr. Royle, it grows up as high above the level of the sea as 13,000 feet, on the peaks of the Himalayas, so that no frost can hurt it here. It would soon carpet a bed for Rhododendrons, like *Musk mimulus*, or it would cover over rock-work, or blocks, or make an edging for any block bank, or cover bare places about a Swiss-cottage, like the common *Tutzan*. D. BEATON.

JOTTINGS ABOUT MATTERS OF TASTE.

Unity of Expression.—"And what about that cranky subject?" good-humouredly write and say many of our friends. "Just let us know the temperature and the soil, and the waterings, certain plants require, and leave us to give *expression* according to our fancy. Your greatest doctors disagree as to the veriest trifles in these matters; why should not I have a fancy of my own? If it pleases me, who has a right to interfere? And by what means can you demonstrate that your ideas, your tastes, your arrangements, are superior to mine?" I own there is great force in statements such as these. We all *will* form opinions of our own, and it requires time, observation, and thought, to alter us a shade in their validity. A man could hardly get along if he did not consider his own plans best in the peculiar circumstances. He must be orthodox. The mischief is that, going a step farther, he is apt to imagine that his *doxy* is the only orthodoxy, while all other doxies are heterodoxy. Would that these ideas were confined to gardening. They meet us in the most momentous affairs of life. In our little world of gardening they foster alike rude, independent action, and a servile, copying spirit. "Oh! such a design will be quite out of character with the rest of your grounds; it will neither contrast nor harmonise with anything." "Indeed! why? I don't see that a fine wheat stack even should be any disagreeable object on my lawn." Another will have beds of his own quite original in their form, and they are twisted and turned into all conceivable quirks and fancies, involving vast labour in making and keeping, and yet never can be made to present an imposing effect. "One arrangement is very striking at a certain place—I will have the same here." It matters not that one position may be on a hill, and the other in a valley—that shutting out may be required in one place, and opening up in another! Water in every shape is a delightful accessory in gardens and pleasure grounds; its very sight cheers—the noise of its gurgle, ripple, or dropping, tranquilises the mind. A gentleman has come from Versailles, or witnessed the unequalled *jet d'eau* at Chatsworth, and forthwith he must have a spirting miniature fountain in his garden, though placed in the highest ground in the neighbourhood, leading every visitor to ask in astonishment where the water comes from. No doubt, even in this respect, much may be done with water-rams and steam power; but if the natural position of the valley is wanting, the *magical* influence of a fountain will ever be lessened, if not destroyed.

Hence it is, notwithstanding all that has been said and written, that the expressions, "good taste, and bad

taste—refined taste, and vulgar taste," are a mere bewildering enigma, being interpreted by as many minds to mean as many different things. Hence, too, our most learned and able writers on taste, gardenesque effect, &c., speak so astutely about "*imitating nature—following nature—taking nature for our guide,*" this same nature being a very useful, somewhat undefinable "looming"—something for adorning a sentence, or clenching an argument. And yet how indefinite is the idea communicated. We know that in all culture of plants we must take our first teachings from nature, ponder over and endeavour to supply the *circumstances* in which plants, unaided by man, flourish the most; but there, in an artistic point of view, the matter mostly ends. Surely it is not intended by the "imitators of nature," that our park scenery is to be the *beau idéal* of a thick forest, that has received its planting from the winds and birds of heaven; that our pleasure grounds are to resemble untrodden prairie, or the thickets by the side of a tropical stream; or that our flower-beds and plant-houses should have their exact counterpart in the circumstances, as well as flowers that deck the mountain's brow, and peep through the tangled glade. All these have their charms, and will ever command admiration; but artistic loveliness—the seen and felt presence of the tending, training hand of man, and yet not offensively obtruded—constitutes the *delight* of the garden. Make the *position* and the *circumstances* connected with every demesne, however humble, the first principle, the ground work of all ornamental gardening operations; and instead of unmeaning combinations, or servile imitations, we shall have little Edens, as interesting as they are diversified. Follow out in such arrangements the *imitation-of-nature* principle, and our Paradises would become monstrous wildernesses, eliciting, after all, but little of the kindred emotions we experience in beholding more natural scenery, that has cost man but little money or labour.

True, the introduction of the wild and picturesque in garden-scenery is *sometimes* attended with the most delightful results. But several things are necessary to secure that result. First: The natural circumstances, as respects character and position, must be suitable. Secondly: The grounds must be so large, that the clearly artistic gardenesque, and the more concealed artistic picturesque, should not be jumbled together. A knotty, wrinkled, hollow pollard, filled with flowers, looks beautiful on a lawn, at some distance from an elegant mansion. An artistic vase looks best near such a house. The beauty of the one and the other consists in their being so separated, that the mind and the eye alike have space for repose, before contemplating their separate beauties. Place them in juxtaposition, and you destroy the peculiar interest of both. Contrasts of opposite styles do not interfere with; they even help, and are necessary to a higher style of beauty, to a more perfect *wholeness*; but then these contrasts must be gradual, not commingled or rudely clashed together; for as we can only contemplate one set of ideas successfully at one and the same moment, for the sake of a bewildering variety and contrast we lose all the benefits and beauties of a "*unity of expression.*"

I feel myself a very tyro in these matters, though convinced as to the general correctness of the inferences adduced. In proportion as civilization and refinement advance, it will be found that these *trifling things* will gain in importance. A good while ago, similar ideas were broached, when, in answer to inquiries, I endeavoured to define the meaning of the terms *Greenhouse* and *Conservatory*, mentioning that the first was a house for preserving plants in pots and boxes, while the latter was a habitation for exotic-plants, planted out in the soil. I endeavoured to shew that a higher style of beauty would be insured, by as much as possible

attending to these characteristics, and thus instead of confounding, promote "*unity of expression.*" I do not recollect if I instanced any facts in confirmation. Let me just mention what convinced me more fully *then*, and what still further confirms me *now*. At one of the Regent's Park Exhibitions, two years ago, the show of American plants was in full magnificence. One peep below the awning was a realization of the dreams of Fairy-land. Even the beauty of the ladies, dazzling as it was, seemed for once to be shaded. Much, no doubt, depended upon the beautiful arrangement, and the ground-plan so diversified, with bank and declivity, miniature hill and dale, but not a little also depended upon the fact, that *not a pot or box were to be seen*. As you traversed the regular exhibition-tents, unity of idea was again so far prevalent, that every thing had its pot, or box, or block, or basket; but when, after this you entered the beautiful conservatory, and felt delighted in examining the fine healthy specimens of growth, there was still a feeling of the *heterogenous* associated with the whole, and that mostly owing to the fact, that many of the best plants *were planted out*, while others stood in large pots, &c., while collections of small pots were so grouped in masses that the individual pots were easily seen. It does not become me to criticize the mode adopted there, or at the rival garden at Chiswick. Public bodies must frequently attend to *much* besides little matters in taste. Still, I think there are few but will own that if in the conservatory at Chiswick, while the side-platform, as now, is devoted to plants in pots, the plants in the centre bed were not *partially*, but *wholly* planted out, or so plunged with their pots as to seem to be so, that a higher style of beauty would be manifested, merely because a unity of expression was thus made apparent. The same facts struck me forcibly as respects the large conservatory at Kew, when I traversed it during the summer. I mention these, because the instances are well known, and because, from the great good that has been done by these Societies, and the influence they properly and deservedly exercise, whatever is done is noted down as an example by gardeners and their employers.

Now I have not seen many places where these simple ideas are *rigidly* carried out, but if I wanted any thing to convince me of their soundness, it would be my recent *glance* at the grounds, and the well-known large conservatory at Chatsworth. The very position of the building is a master-stroke of policy, combining all the advantages of unity of expression, with the pleasure derived from contrast, between the gardenesque, the picturesquely romantic, and the more purely artistic lineaments of the noble building; situated in an amphitheatre of wood (or seemingly so), peculiarly its own. Just fancy such a huge airy building, so attractive to the eye outside, by its stripes of blue and white painting, Crystal Palace fashion, set down near the Palace of the Peak, or in the middle, or even at the side of the highly-kept grounds, and imagine the bewilderment with which a stranger must contemplate the scene, purely from the want of *repose* between the different objects, the inability to grasp the whole at once. You come not, therefore, on the conservatory immediately on leaving the finer dressed grounds. You enter upon walks, which gradually become more picturesque, through the wooded hill, that overhangs alike the dressed grounds and the classic Derwent; these walks, as you traverse them, become more wildly romantic. Embosomed in one nook you see masses of fern—in others, and creeping over huge stones, some of the finer and hardy American plants; now you pass a huge boulder of rock—again, another that rocks at the slightest touch; and ever and anon you pass huge heights of these masses of rocks, piled securely and firmly, yet wildly upon each other, leading your thoughts back to the doings of the giant Titans of old, when they

rolled mountain upon mountain; and just when in the height of your enjoyment, and wondering where all this will lead to, the large conservatory, with its open area for flower-garden plants, bursts upon your view. Now, in the whole of this wild scenery you never see anything directly opposed to nature; but you never lose sight of the fact, that, the natural circumstances secured, the mind and energy of a human designer had accomplished the rest. The plants in the conservatory looked vigorous and healthy; a platform round the side was appropriated to smaller plants in pots. The whole of the plants in the vast centre were planted out, or seemed to be so. No huge tub, or dirty red pot, interfered with the fine base of a stem of one plant, or the graceful, drooping foliage of another. Here, as well as in the rest of the grounds, the beauty was enhanced from the felt "unity of expression" that prevailed. But I must stop.

R. FISH.

SEEDLING DAHLIAS FOR 1853.

A FEW rambling notes by a friend, who signs himself *Observer*, has been sent to me, and I know the writer to be not only a good and most successful grower, but also one of the best judges of the day of the Dahlia.

He says, "I have seen all the following, and can speak confidently of their merits. I begin with Rawling's *Lilac King*; this is one of the gems of the season; fine lilac; the centre is the summit of perfection, very symmetrical. It is with me No. 1.

"*Sir John Franklin* (Turner's).—This is very much in form and substance like the preceding, with all the properties of a first-rate Dahlia; colour, dark orange-buff.

"*Queen Victoria* (Wheeler's).—Yellow, edged with purple; form, first-rate, and very beautiful; the centre well filled up.

"*Brilliant* (Rawling's).—Bright scarlet of the finest form; centre well up; easy to grow; decidedly the finest scarlet Dahlia ever produced; first-rate in every point.

"*Lord Byron* (Pope's).—Is a flower I noticed at several of the leading shows; the form is first-rate; colour, a clear bright salmon.

"*Miss Caroline* (Brettell's).—White, tipped with purple; a flower resembling the *Marchioness of Cornwallis* Dahlia, but without its faults; every flower appears to close well.

"These six flowers are the gems of the season, and have received the bulk of the certificates. No amateur can mistake, if he wishes to grow the best six varieties for 1853.

"I now go on to notice about six more, which will comprise all I intend speculating in this year among the show varieties.

"*Plantagenet* (Turner's).—Shaded purple, very constant, and a good colour.

"*Bob* (Turner's).—Scarlet, rather flat in the face, not equal to Rawling's *Brilliant*; rather different in colour, but useful, as good scarlets are rather scarce.

"*Lady Dalrymple* (Turvill's).—Light, edged with pink; a flower well up in the centre; of good form; rather small, but useful.

"*Annie Neville* (Keynes's).—Light, edged with purple; well up in the centre, but rather deficient in outline, but useful from its colour.

"*British Queen* (Drummond's).—Light, deeply edged with purple. I have only seen a flower or two, but what I have seen were good; rather thin, and I should say difficult to close.

"*Mrs. Stein* (Stein's).—Shaded purple, rather small, but well formed; one I should grow for its novel colour and shading. It is a very likely show-flower.

"These are all the flowers I have noticed out of a great quantity exhibited at the shows, and I have attended many of them. The *fancy varieties* appear to have made very slow progress this season; in fact, there has been

very few shown. The best I have seen this year is *Mrs. James Rawlings*, a sort of puce tipped with white. The flower took two prizes at the Surrey Gardens. I liked it there very much.

"*Wonderful* (Keynes's) is a striped flower, one of the best striped varieties, and has taken several prizes. There should be a class for striped flowers, to encourage their production.

"*Unanimity* (Edwards's).—Another distinctly-striped flower. If a new class is made for stripes these flowers will be in demand.

"These comprise my observations on the new flowers. If these notes are of any use to your readers, I may be induced to give my opinion on the last year's flowers, as I have grown most of them.—OBSERVER."

I have very few to add to "Observer's" list; he is truly a correct observer, and our amateur friends, growers of dahlias, cannot do better than follow his advice. I pledge myself to the correctness of his descriptions.

Mr. Stein, of Highgate, has a promising seedling, a light scarlet, named *Robinson*, with great depth of petal, of good substance, and excellent form; the same raiser has also one named *Mr. Lockner*, a pinkish-lilac, novel in colour, good in substance, and of first-rate form.

Also, one named *Mr. Dickson*, a blush-white, smooth edges, well up in the centre, and of excellent form. The suggestion "Observer" makes, that he is willing to give his experience and opinion of last year's Dahlias would, we are sure, be useful and acceptable to the readers of THE COTTAGE GARDENER.

T. APPLEBY.

WORK FOR WET DAYS.

UNLIKE the last and several previous seasons, the present one seems likely to visit us with all the arrears of rain which our weather prophets told us was due from the dry winter and spring, which, if not followed by abundance of rains in June and subsequently, would have left our ponds, streams, and wells, lower than was ever known; as it was, they were very low, even in mid-winter, and still more so in May; however, there seems no reason to think that water will have to be carted at Christmas this season, as it was last, to places where it was only necessary to do so in the summer before. The abundant rains of the last month (to say nothing of the present one and what may follow) will certainly replenish all our fountains, and for some time to come the ground is not likely to lack moisture; but in the midst of all this wet weather, the question arises, What are we to do; since out-door work is no longer a duty that can be performed? It then becomes us to see what can be done to advantage under cover in those successional wet days we have been of late so often visited with.

Where there is ample shed-room, *the dung for mushroom-beds* may be prepared, and the beds made, spawned, and other work connected therewith done; not forgetting to look to those beds that are in bearing, or may be expected to come into use soon. These latter, if they have been enduring the drying influence of fire-heat in any shape, must be supplied with water at those parts most exposed. It often happens that a mushroom-bed is formed in some back shed where the stoke-holes are placed. Now these fires, though heating the structures on the other side, very often diffuse an amount of heat backwards sufficient to maintain the temperature of the shed several degrees above similar places where there is no fire. Now this is very useful, as, notwithstanding the healthy, fine mushrooms that are often gathered in the open air until very late in the season, sometimes to Christmas, still some little warmth is necessary to insure a crop at that time, and still more so afterwards. Now

a mushroom-bed made in such a situation, is often more productive than those in "the house" set apart expressly for them; so that the amateur, or he of small means, who has no better place than a corner of half-a-dozen square yards, may, nevertheless, try his hand with a fair chance to succeed in the culture of this capricious production. This vacant space we suppose to be bounded on one or two sides by the wall of the building; on the other sides some temporary erection must also be put up, to keep the dung, &c., from breaking down when looking at the bed, gathering the crop, &c. Where dung is plentiful, and a bed of this sort is to make, I do not like the plan of throwing aside so very much of the litter as is done in preparing dung for beds in a regular mushroom-house, where they are obliged to be made so thin; on the contrary, leave a considerable part with the dung, and in making the bed, let it be double the thickness of the others, about two feet is not too thick, but be sure the dung has been well prepared by frequent turnings, and until all the rank heat is driven off. Now this work may be all very well done on wet days; in fact, if the materials be all inside, it is, perhaps, better done at that time than in dry weather. The spawning of beds that have been made a few days, and have been left to prove their heating powers, may also be performed, and earthing them over may also be done at once; this, in addition to preparing dung, &c., for future beds, may form a very profitable employment for a wet day.

It has been customary, from time out of mind, to *rope Onions* and hang them up; and though some of our younger brethren may dispute the doctrine of their keeping better in that position than when lying on a shelf or dry floor, yet we are not quite sure our grandfathers were at fault here. A string tied tight about the neck of the onion is likely to prevent the escape of its juices through that channel, while the position the rope is usually placed in is certainly more conducive to its preservation than when it is, in an indirect manner, in contact with mother earth. We like an ordinary hay or straw band best for a centre; and care should be taken not to bruise the onions in the handling. And we have no doubt but those who compare notes will be led to say in March, that tied-up onions have kept better than others. This job may advantageously be performed on wet days.

Root crops may also be looked to. *Carrots* keep quite as well in an ordinary cellar when not packed into that close mass so common to some; in fact, I object to pack them at all until December, or when the moisture, which more or less accompanies a heap of most productions, passes off; they may, however, be looked to now, and any symptoms of decay, or decaying matter of other kinds, removed, so as to give no chance to putrefaction spreading through neglect. *Beet* and *Parsnips* we suppose to be in the ground still; but that most uncertain of all productions, *the Potato*, must be looked to, and that frequently, as report would seem to imply that the whole crop of 1852 is, in many places, fast approaching a state of dissolution; and, if we regard the opinion of the worst of those evil prophets who pretend to foretel future events, both the stock of the ensuing winter, and the seed of another year, will be a dead letter. Without going the length of fearing such a result, I must own that I have never seen the disease so bad as it is this season in this district; still I hope that a remnant will be left for us to try again, to see if this scourge cannot in some way be counteracted. All that can now be done with those potatoes which show symptoms of decaying, will be to pick out all the bad ones as they show themselves, and, after drying the others as well as can be done, to dust them with quick lime. This powerful agent is an antidote to most of the fungus tribe, to which this disease is said to belong.

Another job for wet days is the making and sorting of *Label Sticks* for various purposes; some very small ones may be prepared, and tied up in bundles, to name varieties of bedding-out plants, and others that may be potted off when spring comes round; larger ones, but of the same material, may be made for labelling seed pans and other uses, when something more than the mere name may be added. Then, again, large strong ones of the best enduring wood may be made for marking out the position of bulbs, and other unseen plants, that may be scattered over mixed borders; these, when not marked in some way, are apt to have the spade driven right into the centre of them when the border is dug; but a mere mark is not sufficient, better smooth one end of the stake, rub on a little white paint, and at once write the name with a pencil. If this be well-done, it generally lasts as long as the wood endures. These should be rather stubby than tall, as they are not wanted to show themselves conspicuously; but another kind may be made longer, to mark the varieties of kitchen vegetables sown and planted. These ought to be of such a height as to stand to be seen when the plants have grown considerably; for this latter purpose, rounded stakes, flattened and smoothed at one end, are as good as any.

All these, and many more duties, may be performed on wet days, to say nothing of that "ridding-up" of the sheds and other places, which, in spite of regular good keeping, require now and then "a thorough cleaning out."
J. ROBSON.

VINES AT BISHOP STORTFORD.

FINE flowers, fine fruits, and fine vegetables, form subjects for poets and painters, are eagerly sought after by the rich, and looked at with longing eyes by the poor.

A recent visit to Hampton Court, and to Bishop Stortford, has proved to me that there is no royal road to gardening. At Hampton Court, all the appliances of the public purse do not enable our Queen to have at her desert such grapes as are to be seen in a private garden at Bishop Stortford. The Hampton Court vine has been celebrated for nearly 200 years, as a *rara arbor*, and so it was, till others and better were to be found. I have no desire to detract from the splendid growth and excellent training of the Hampton Court vine, but when I find a private gentleman, of moderate means, and with a moderate man for a gardener, can beat the royal vine, I think I am justified in saying, there is no royal road to horticulture or to knowledge.

I will endeavour to describe to such readers of THE COTTAGE GARDENER as cannot visit the royal and the plebian vines, what I saw, for their benefit. The vineries at Stortford consist of two well-glazed, lean-to houses, each sixty feet long, eighteen wide, and sixteen high at the back.

In one house there are fourteen vines of the Black Hambro' kind, entering the house (by a very simple contrivance described below), not up the rafters, but half-way between the rafters, and so up the roof, consequently enjoying all the light which can be had under a glazed roof. Each vine has on it about fifty bunches of grapes, of an average weight of 1½ lb., and in size about a small pigeon's egg. The colour is perfect, and but for a little rust this year, finer grapes never was produced.

In the other house there are the same number of lights, and about the same number of vines of the Muscat kind. These vines enter the house precisely as the others do; there are, as nearly as possible, fifty bunches of grapes on each vine, and each bunch will, when ripe, perhaps average from 2½ lbs. to 3 lbs. The grapes are very large, very even in size, and very clean in growth. The vines in both houses are in perfect health, always feeding upon a rich dish, which does justice to them, and which they do justice to. The leaves are neither gross nor small, but clean, transparent, and full of health, each leaf seems the counterpart of its neighbour, and which set off the fruit quite as much as the fruit sets off them.

The stem of these vines, only ten years growth, is bright

and clean, and as thick as a burly yeoman's arm. There has been no rampant growth, and there is none now. They are pruned upon the short and close spur system, and growing, as if by order, an exact and moderate length. The houses in which the vines grow and flourish face the south, at an angle of forty-five degrees; they stand upon a steeply-sloping bank, and are planted in a well-drained and well-made bed, in such a way that they can be looked after, and trained with nicety and ease.

There is nothing royal in the houses, and nothing royal about the man who waits upon them. The houses are clean and sweet, and the man is civil, without servility. There is an air of order and industry about the place, that makes any thoughtful person believe that where there is a will there is a way.

At Hampton Court the vine is large and fully grown, and managed from its origin upon the long-rod system; age, however, begins to tell upon it. The grapes this year are small, and many bunches will never colour, and never ripen. The house is good in size, and clean, but grand as it is, and as it was, it will not compete with the plebeian's vine in Hertfordshire.

There is something refreshing to my mind in the retrospect; it makes one think how much a man may do who puts his shoulder to the wheel. To be up and doing is the way; never to be dashed, and never to be daunted; a no-surrender man is the man for me, and the British, when once fairly on the scent, succeed wonderfully, excel everybody, because they look far and near for information on any subject they take up. The French invent, and we perfect. The foreigner is full of theory; we are full of practice.

I am well aware there are many aristocratic vines which will compete with those which I have described, but the reader must recollect these aristocratic vines cost an aristocratic outlay; whereas these plebeian vines are tended by a solitary man, who must keep watch and ward over them from one end of the year to the other.

I ought to mention that the Stortford vines are not forced, but merely cared for. Each house is warmed by a flue, and these flues are only used in very chilly or very damp days.

If the foregoing is thought worthy of a place in your journal, I may, perhaps, take the liberty of entering upon a further correspondence at some future time.*—THOS. MOXON.

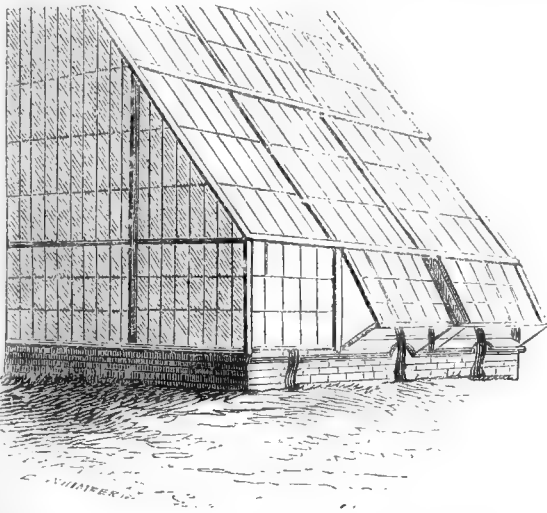

The above mode is adopted for admitting the stems of the vines into the vinery without holes in the brick-work. A broad plate of thick wood projects about a foot from the wall, a semicircular piece is cut out of this for the vine-stem to sink into, and the front lights can then shut down close upon the plate. In the above drawing, two windows are shown propped open, and one is closed. At Bishop Stortford vinery, a piece of wooden plate is fastened to each window, out of that the semicircular piece is cut, so that the plate shuts down upon the vine-stem, but causes all the front lights to project in a slanting direction, even when closed.

* The sooner the better.—ED. C. G.

THE CULTIVATION AND HARVESTING OF TOBACCO.

IN THE UNITED STATES.—Sow as soon as frost is fairly out of the ground, or even in February, if you can get a warm spell of weather sufficiently dry to enable you properly to prepare the seed bed. Select a warm, sheltered spot of virgin land, free from grass and weeds, dig it up lightly, and put the surface in very fine order. For a bed of twelve or fourteen yards square, mix a large wine glass full of seed with about a peck of fine wood-ashes, so as to divide the seed equally through it, that it may be more evenly sown. Sow broadcast on the surface, rake with a fine-toothed rake very lightly, and tread or roll the ground very firmly.

IN ENGLAND.—Sow in a bed, with gentle heat, about the 10th April, or, if only for a few plants, in a small box, or large garden pot, under a frame, with little heat, until the plants appear; but take care that the plants do not get long stalks, as that is fatal to a good plant. They should, when young, be as flat to the ground as possible; if they come up too thick, wait till some have got five or six leaves, when carefully prick them out, so as to give more room for the others to come on; when the largest leaves are about three inches long, plant out where they are to remain, not nearer than three feet apart—in light, warm, well-drained soil, not over rich; if artificially made, let well-rotted leaf-mould form a large portion. Keep the ground well stirred and pricked around it during the period of its growth. The chief ingredients it seeks are potash and ammonia; the latter it obtains in a large amount from the atmosphere, through its immense leaves. As soon as any of its blossoms show colour, break off the head of the plant, including also the small top leaves; this will soon increase the size of the leaves, but, at the same time, the plant will again make an effort to blossom, by throwing out side-shoots. As soon as these become about two inches long, or as thick as your little finger, break them all off. If the season is not too wet, the plant will now begin to open; the ground leaves first, and so upwards. But sometimes it will become necessary to let the plant stand till you have to break off a second set of side-shoots. In America, and in a large crop, you must judge by experience when the plant has the best average of matured leaves upon it, and then cut it down and hang it up in a large, open, and airy barn to cure; but in England, on a small scale, you had better strip each leaf as it becomes ripe, and only cut down what remains when you are afraid of a sharp frost. The small ground leaves generally turn yellow, and in wet weather get partially damaged; they ought then to be pulled; with a large needle and piece of twine, string them and hang them up to dry, leaving them so that air can freely pass between them, and in as airy a place as possible, but under cover from night air, dew, or rain. These leaves will cure light and thin, and make very mild smoking tobacco; the next set of leaves may, or may not, turn yellow, but will look blotchy and rather transparent looking; they may then be pulled and treated in the same way, and so on as they ripen; but seldom, if ever, the whole of the leaves will ripen in this country; so when you anticipate a sharp frost, cut the plant down, and hang it up also to dry. Now, cured tobacco always rapidly absorbs moisture from the atmosphere, and can only be handled when it has given a little, but it must now remain until every vein in the leaf has become *thoroughly dry*, and not a particle of sap remains in it; in this damp climate that may be a very long time. After it has once been thoroughly dry and crisp, watch the next change in the atmosphere, and as soon as it is soft enough to be safely handled, and the middle vein is not crisp enough to snap when bent, take it down and tie it in small bundles, or hands; put these, if on a small scale, in a box, packed evenly with the butts outside, press them moderately, when they will undergo a slight heat; but this is the most delicate and nice part of managing a crop of tobacco; on it depends, most materially, its good flavour, and six or eight hours neglect may injure the whole crop, indeed totally spoil it; on a small scale, however, it cannot suffer so much from the same cause; when fermentation once commences, it sets in with great rapidity; all that is requisite, is that a very slight warmth should be generated, then open it all, shake the hands in the air, so as to let off the heat, and repack it again lightly, or, if it is in the right

condition, you may pack it down as tight as possible into any barrel or box, and it will not heat any more; and the tighter it is packed the better it will preserve its flavour. The sweating gets rid of the bitter gum that coats it, and, when properly conditioned, it should have a fine fresh, fragrant smell, somewhat similar to new hay. The principle of curing tobacco is precisely similar to the correct principle of making good hay, or clover hay, only a more delicate operation. Clover, or grass, when partially cured, should always be put into heaps until fermentation takes place, give it then a good shaking out and airing, and it will never injure by heating in the stack; so with tobacco, only it must be managed with a little more nicety, as it changes its condition so rapidly with each atmospheric change. Nitrate of potass is the chief ingredient in its ashes. The stalk or stem of the plant is of no use except for manure, for which it is valuable for any of the cereal crops.

It is erroneously supposed by many to be a great exhauster of the soil, and to require very rich ground. The idea is a monstrous fallacy, based upon practical results, without tracing them to their proper cause. Rich ground will make a very heavy crop of inferior tobacco, but the finest tobacco that can be grown is upon a poor sandy virgin soil. The first and second season after clearing off the timber, when the plant can obtain a sufficient quantity of potash from the little vegetable leaf-mould that is on the surface, combining which with the large quantity of ammonia its extensive system of leaves enables it to absorb from the atmosphere, it forms the nitrate of potass which, with some silicates, forms the principal ingredient of its ashes. A wet season is the most fatal to tobacco, especially if water lies about the roots; for which reason a little side or very undulating ground will make the brightest crops.

LEYTON.

[The correspondent who has obliged us with this, says it is furnished by a Maryland tobacco planter, now resident, and for the last two or three years, in England, and, therefore, may be relied on.—ED. C. G.]

THE BEST FUCHSIAS.

ALLOW me to say a few words on the six best Fuchsias that are out. For the three dark with purple corolla;—First, take *Nil Desperandum*, *Clapton Hero*, and *Alpha*. These are the best three darks, so far as quality is the object. If size, then take *Orion*, *Don Giovanni*, and *Smith's Kossuth*. For the light, take *Banks's Conspicua*, *Ariel* (Banks), and *Princess* (Banks). These I have found to be the most useful light ones that are grown. Their quality I have tested, therefore, if your correspondent, "Lacy," has not them in his collection, I should advise him to secure them; they are reasonable in price. He may obtain all the varieties mentioned above, at Mr. Smith's, Tollington Nursery, Islington. If "Lacy" wants something nearer perfection than the Fuchsias I have noticed, he must stop till the spring of 1853. Then he may procure *Banks's Glory*—than which in dark Fuchsias there is nothing to equal it. The beautiful deep crimson of the tube and sepals, the corolla being a glossy violet purple, forms a most gratifying contrast. It has had the honour of six first class certificates at the principal shows this season. Likewise a white Fuchsia, *Lady Franklin*, is considered the best light-coloured. The tube and sepals being so pure white, and the corolla pinky purple; it is quite entering into a new class of Fuchsias. If "Lacy" procures these in the spring, he need not fear competition. There are a few others that ought not to be omitted, if a first-rate collection is wanted. I will name them at a future time.—R. WEATHERILL.

COST OF KEEPING COCHIN-CHINA FOWLS.

UNDER the impression that I had sufficiently trespassed on the space of your paper, and the patience of your readers, I had determined to trouble you no more; but Anster Bonn's last letter calls for some remark. I do full justice to her zeal, her intelligence, and knowledge of the good qualities of Cochin-China poultry—I admire her candour; but whilst I read with pleasure her remarks, and readily

believe she is fully impressed with the reality of all she states, I must, with all courtesy, be permitted to add, that I am not the least convinced that Cochin-Chinas have any right to the great superiority she wishes to claim for them; nor do I think that Anster Bonn, keeping only one *sort* of poultry, can enter into this comparative discussion with a mind as unprejudiced as one who, like myself, keeps several sorts of what are supposed to be the best poultry, and who (only wishing to arrive at what is really the best breed) has no prejudice or partiality to gratify.

When Anster Bonn *did* keep *other* poultry, by her own account they were "indifferent Dorking, Spanish, a mixed lot, &c.;" but in my case I claim to have some of the best Cochin-Chinas in England, bred from Mr. Sturgeon's and Mr. Andrews's best birds—not (as Anster Bonn hints) "with length of leg, and upright gait," likely to have any cross of Malay; but short-legged, good in colour and shape; and as you, Mr. Editor, have seen my birds, you will give me credit for not decrying Cochins from envy. I agree perfectly in many of the good qualities advanced by Anster Bonn in favour of her feathered friends—I admire their laying powers, their docility and their *early maturity*; but even on this last point something may be said. I have heard (and am inclined to believe) that an opinion is gaining ground with some of the oldest, most experienced Cochin-China fanciers, that if this poultry does come into use earlier than other fowls, so they go out of use proportionably earlier. If this proves to be so, one of the great merits claimed for them is much weakened. Time must prove this. I am inclined to attach great weight to this opinion, coming to me from the quarter it did.

Anster Bonn, *even*, cannot defend the size of their eggs. I heard remarked at the breakfast-table the other morning, when some Cochin-China eggs appeared, "Do you call *these* eggs? Why, I could eat a dozen of them!" As for myself, I can sympathise with others, I have detested eggs ever since having been let in for a "horrid thing," I was comforted by hearing that I had *only* eaten for a "breakfast egg" what was called a "dinner egg" (an abomination of six weeks old).

Two points must remain in dispute between Anster Bonn and myself:—The quality of Cochins as table fowls; and the quantity of food they consume. The first must be always a matter of taste. I have now tried several, and *still* think they are not equal to *any* Dorking (Mr. Baily's, or anybody's). Of the dinner to which Anster Bonn alludes I had heard some rumour; and I do not doubt Anster Bonn's kindness and candour will induce her to inform us, whether the general opinion in the dining-room was pronounced as decidedly in favour of the Cochin-China as she tells us it was "out of the dining-room." I have heard a whisper it was not so.

Anster Bonn's statement as to the expense of food of her fowls is to me perfectly astounding. "One penny a week per head!" It strikes me, either that I (from being, I suppose, a friend to the farmer) have been paying too much for my corn, or that there is a "screw loose" in the domestic economy of my poultry-pard. I have never kept any correct account of the weekly expense per head, but in a rough way I have *supposed* it to be from 3d. to 3½d. per head weekly (unless with the *run* of a farm-yard, when it would be much less), for common fowls, and more for Cochin-Chinas.

I have heard several remarks of—"A penny a-week, indeed! Ridiculous! Much more like a penny a-day, &c." I offered an old woman, who *walks* some of my fowls, a penny! twopenny! threepenny! a-week. She refused them all.

A poultry dealer of my acquaintance puts it at 2½d. a-week. "But then, Sir (he added), I can get my stuff cheaper than you." I am determined, now, to put this to the test. I have confined two lots of fowls (each consists of one Cochin-China cock, and two hens) in two separate yards. A quantity of food had been weighed previously, in separate boxes, for them. From these they will be fed, and as what is left at the end of the week will be weighed, I can ascertain to half-an-ounce what the consumption of food has been, and your readers shall be acquainted with the consumption, the cost, the number of eggs laid in the time (and their joint weight), and they may then form their

own opinion. These *lots*, having no grass in their yards, will be furnished with green meat, *gratis*.

I am also trying the same experiment with our Cochinchina cockerills at a distance (the results of which you shall hear), and I intend to try the same also with some Spanish poultry.

I will take every care that the trial shall be conducted with the most perfect fairness, and I feel great interest in the result.

I have no leaning one way or the other. I have no object to gain, or prejudice to gratify. I really wish to ascertain, which is the cheapest and most profitable fowl to the cottager. And whilst gladly acknowledging the many merits of my friends, the Cochins, I honestly believe, that as being somewhat of a novelty, they have taken a higher perch in the poultry stage, than they are entitled to, or than they will retain. In the words of the old farce—"I may be wrong, but that's my opinion." But should further experience prove the error, no one will more cheerfully proclaim it, or more humbly acknowledge it than GALLUS.

TO CORRESPONDENTS.

** We request that no one will write to the departmental writers of THE COTTAGE GARDENER. It gives them unjustifiable trouble and expense. All communications should be addressed "To the Editor of the Cottage Gardener, 2, Amen Corner, Paternoster Row, London."

HOLLYHOCKS.—A very trustworthy correspondent at Durham writes as follows:—"I received the following from Mr. Chater, of Saffron Walden, and they have undoubtedly thrown all the other varieties into the shade:—*Comet* (Chater), ruby-red, large; *Joan of Arc* (Parsons), large, bluish; *Lady Braybrooke* (Parsons), crimson; *Magnum Bonum*, maroon; *Meteor* (Bircham), crimson; *Pulchella* (Chater), pink; *Saffiano* (Parsons), pinkish salmon, a splendid flower; *Triumphant* (Parsons), pale primrose, flower very full; *Spectabilis* (Chater), shaded salmon; *Walden Gem* (Chater), ruby-crimson; *White Perfection* (Chater), splendid white; *Mr. C. Barron* (Chater), pinkish salmon. As the Hollyhock has only lately been introduced into the north as a show flower, I think your numerous readers here might be benefited by such lists from amateurs who have grown such flowers, besides being aware that the information is sent by individuals that have no pecuniary interest to promote by making false representations." We shall most readily insert such lists, and any amateur sending us such a list of flowers which he has cultivated and approves, will greatly oblige us. We are obtaining similar lists from professional gardeners, and begin to-day with the *Dahlia*.

ROOKS.—In reply to P. P., who wishes for information as to the most practical way of establishing a rookery, I beg to state, that the first settlement of rooks upon our property was effected by conveying a nest of these birds, when the young were hatched, and fixing it securely in a tree. My sister gave a daring boy a trifle to take the nest, and place it in its new position, from which small beginning a rookery has sprung. I believe the rookery from which the parent nest came was that upon a neighbouring estate, a very few fields from what is now our own; so that the old birds could easily follow the cries of their young. This took place so many years ago, that I do not remember exactly from whence the nest was brought; but if it did not come from the nearest rookery, it must have been from one seven or eight miles off, which I think scarcely possible. Beech and elm are the trees preferred by rooks; our own never fix upon the oaks and limes that stand close to their settlement, but remain exclusively attached to the tall beeches.—R. F. I.

DOUBLE AND SINGLE FLOWER-BUDS.—*Senilis* says, "At page 424 of the last volume, I read, 'We know of no test whereby to know a double from a single Hollyhock before the blossom opens, except that the flower-buds of the double are more globular, and larger.' This leads me back fourteen years, next January, when two of the best and most celebrated *Camellia* growers in England (nurserymen) came to see my *Camellias*. Among other plants, I had a beautiful specimen of a seedling *Camellia*, then in full bud for the first time, but none of them were expected to open before April. The plant had all the appearance of turning out one of the best seedlings of that period; the leaves were as thick and round as those of the old double-striped, or variegated; the young wood was stout and short-jointed, and the buds were as large and round as any in the house at that stage of development. My visitors made an offer of ten guineas for this plant, and would "take all chances;" but no! the offer rather turned me the other way. Still I regretted that I did not know of a test whereby to know a double from a single *Camellia* thus early. A young German, who overheard our conversation, the offer, and my regret, grinned from ear to ear, but said nought until the visitors departed, when, after a little fishing, I got out of him the secret how any flower-bud could be proved as being that of a double or single flower. Cut the bud through the middle, and the secret is out to view—a single folding round the stamens; the double all folds and no stamens. How very simple! but well worth knowing."

TEA-SCENTED ROSES (Q.)—In very severe weather it is a good plan to cover them with a mat, as you propose; and if you could get moss enough to cover the whole surface of the bed an inch or two, and then stick a lot of small, dry branches, such as the tops of pea sticks, in among them, the frost will not harm them, even in so young a state. Dry sticks, if they are placed thick enough, are much better for protection than boughs of evergreens.

FUCHSIA SPECTABILIS (W. S.)—We are not aware that it has been exhibited at any of the shows, and the less that is said about it the better. Perhaps some of our correspondents could give directions for its

culture. We have one blooming well in a warm border, the pot being plunged there all the summer.

GLOXINIAS (Ibid.)—As your plants have made no bulbs, you must not let them get quite dry this winter, else they will slip through your fingers.

CANTUA DEFENDENS (W. S.)—A warm house was sure to play vengeance with it. The very coldest part in the front of a cold pit, where the sun and frost could not reach it, is what it likes.

HICKORY NUTS (H. R. L. N.)—You have brought some Hickory Nuts (*Carya*) with you from Canada, and wish to know the best mode of culture, and in what soil they should be grown. Preserve them in sand, in a cool cellar, and sow them in rows thinly, in the spring, about the end of March. The soil they like is a strong loam, deep and rich, and well drained. Allow them to remain in the seed-rows for two years, then transplant them in October, into nursery-rows, and after the second year transplant them finally where they are to grow to be trees.

PLANTING CONIFERS (M. S.—, Wigan)—You will see Mr. Appleby has answered your queries in several back numbers. If you noticed rightly, the season for planting is mentioned by him to be, *first*, August and September, and then March. The grand object to aim at, should be to plant them at such season as will allow them time to force new roots before the early frosts of winter and the dry weather of spring. The state of the season, whether autumn or spring, will have influence upon the planting. If wet and cold, wait till it is moderately dry and warm. The small bit of a plant you sent we cannot make out. Send it again when in bloom.

BEES.—B. B. says:—"Since I sent you my statement (see pp. 15-16), I have observed in hive No. 2, that the drones are *not* all destroyed, three or four made their appearance on the 26th of Sept., and about the same time from eight to ten bees arrived with bee bread. I have always been led to consider the appearance of drones at this time is a bad sign. If it be really so, how would you have me act? I have been feeding the bees in this hive for the last fourteen days."

WINTERING SCARLET GERANIUMS (B. B.)—Your frame filled with coal-ashes will do excellently to plunge the pots in; and as you have them already cut back, you will have nothing to do but to admit air to them freely whenever the temperature permits, and to exclude frost by covering the glass with hay and mats. The same treatment will exactly suit your *Verbenas*.

THOUSAND-HEADED CABBAGE (Doncaster)—For late spring-feed for sheep, sow early in March, prick the seedlings out when three inches high, and plant out finally early in July. You may continue planting out throughout August and early September, as more ground becomes vacant. Plant in rows, three feet apart each way.

PLANTS FOR FLOWER-BEDS (Ignotus)—We hope to begin the publication of plans next week.

PINE-CULTURE (Stupid)—You will have all your queries answered in Mr. Errington's papers.

APPLES (B)—Six *Desert Apples for Espaliers*, good bearers and good flavoured, are Lamb Abbey Pearmain, Kerry Pippin, Old Nonpareil, Scarlet Nonpareil, and Sturmer Pippin. Six *Kitchen Apples for Espaliers* are Hawthornden, Alfriston, Wareham Russet, Blenheim Orange, Keswick Codling, and Waltham Abbey Seedling.

LABURNUM NOW BLOOMING (A Subscriber)—It is not at all uncommon for untimely blossoms to appear on this tree.

WHITE COCHIN-CHINA FOWLS.—*Aliquis* wishes to know where, and at what price per pair, he can purchase these. You will see two advertisements of them in our last number.

SPANISH CHESNUT SEEDLINGS (T. M. W.)—These are quite hardy, and will require no protection.

TOBACCO CULTURE (A Friar)—See a very full and excellent paper on the subject in our present number.

AUTUMN PLANTING POTATOES (J. R., Everton)—Dig all your light soil over in November, and plant as it is dug; that is, as soon as space enough is dug for a row plant the sets with a dibble, six or seven inches deep, and do not let the ground be trod upon afterwards. Do not add manure of any kind, but in March sow over the surface Epsom Salt, at the rate of three pounds to every hundred square yards. Do not plant any but the earliest ripening kinds; the Kemps are too late.

BACK NUMBERS (Omega)—If you send as you propose, you can have the numbers and the volume bound. Send a note with them, stating what you wish, and your address. Other questions next week.

ADVERTISEMENTS (A Watcher)—It is quite impossible for us to answer for the truth of statements in advertisements. We should have a nice time of it if we had to test the worth of everything advertised. If we are especially asked for an opinion upon any one article, we can do no more than obtain relative information, if possible.

DISEASES OF POULTRY (Ibid.)—You will confer a great favour by communicating your observations upon this subject.

FORGET-ME-NOT SEED (Ellen)—Perhaps Mr. Carter, Seedsman, High Holborn, London, can supply you. Have any of our readers some seed of this flower sacred to remembrance?

PURPLE-FLOWERED CLIMBER (A Subscriber)—This which you saw against the wall of a villa at Torquay, we have little doubt is *Ceanothus azureus*. It is highly ornamental, and the more to be prized because blooming in autumn.

THE LONDON MANURE COM-

PANY beg to offer as under:—
Corn Manure, most valuable for spring dressing, Concentrated Urate, Super-Phosphate of Lime, Nitrate of Soda, Sulphate of Ammonia, Fishery and Agricultural Salt, Gypsum, Fossil Bones, Sulphuric Acid, and every other artificial manure; also, a constant supply of English and Foreign Linseed Cake.

Peruvian Guano, guaranteed the genuine importation of Messrs. A. Gibbs and Sons, £9 10s per ton, or £9 5s in quantities of five tons or upwards. **EDWARD PURSER, Secretary,** 40, Bridge Street Blackfriars.

THE ROYAL EXHIBITION—

39, Albemarle Street, Piccadilly, observe, opposite the York Hotel.—Valuable newly-invented, very small, powerful, Waistcoat pocket Glass, the size of a Walnut, to discern minute objects at a distance of from four to five miles, which is found to be invaluable for yachting, and to Sportsmen, Gentlemen, and Gamekeepers. Telescopes, possessing such extraordinary power, that some 3½ inches, with an extra eye-piece, will show distinctly Jupiter's Moons, Saturn's Ring, and the double Stars. They supersede every other kind, and are of all sizes for the Waistcoat pocket, Shooting, Military purposes, &c. Opera and Race-course Glasses with wonderful power; a minute object can be clearly seen, from ten to twelve miles distant. Invaluable newly-invented Spectacle.

Deafness—New Discovery—The Organic Vibrator, an extraordinary powerful, small, newly-invented instrument, for deafness, entirely different from all others, to surpass anything of the kind that has been, or probably ever can be produced. Being of the same colour as the skin, is not perceptible; it enables deaf persons to hear distinctly at church and at public assemblies; the unpleasant sensation of singing noises in the ears are entirely removed; and it affords all the assistance that possibly could be desired.

S. & B. SOLOMONS, Aurists and Opticians, 39, Albemarle Street, Piccadilly. Observe, opposite the York Hotel.

Lately published, price 5s 6d.

MRS. LOUDON'S WORKS ON BOTANY AND GARDENING.

New Editions, Revised and Improved.

These Volumes contain beautifully Coloured Drawings of above seventeen hundred of the choicest species of Garden and Greenhouse Plants and Wild Flowers, with descriptions, and full directions for cultivation.

In 4to., cloth lettered, price £1 15s; half-bound morocco, gilt edges, £2 2s.

THE LADIES' FLOWER-GARDEN OF ORNAMENTAL ANNUALS. In Forty-eight Coloured Plates, containing upwards of Three Hundred Figures of the most showy and interesting Annual Flowers.

In 4to., cloth lettered, price £2 2s; half-bound morocco, gilt edges, £2 10s.

THE LADIES' FLOWER-GARDEN OF ORNAMENTAL BULBOUS PLANTS. In Fifty-eight Coloured Plates, containing above Three Hundred Figures of the most desirable Bulbous Flowers.

In 4to., cloth lettered, price £3; half-bound morocco, gilt edges, £3 8s.

THE LADIES' FLOWER-GARDEN OF ORNAMENTAL PERENNIALS. In Ninety Coloured Plates, containing Five Hundred Figures of Hardy Perennial Flowers.

In 4to., cloth lettered, price £1 11s 6d; half-bound morocco, gilt edges, £2.

THE LADIES' FLOWER-GARDEN OF ORNAMENTAL GREENHOUSE PLANTS. In Forty-two Coloured Plates, and containing about Three Hundred Figures of the most desirable Greenhouse Plants.

In 4to., cloth lettered, price £2 2s; half-bound morocco, gilt edges, £2 10s.

BRITISH WILD FLOWERS. In Sixty Plates, containing Three Hundred and Fifty Species, beautifully Coloured.

London: Wm. S. OER & Co., Amen-Corner.

BASS AND BROWN'S NEW AUTUMN CATALOGUE is now ready, and will be sent free on receipt of Three Postage Stamps.

BEST NEW GERANIUMS OF LAST SEASON. Strong Plants now ready. **BASS AND BROWN** have the pleasure to offer, as under, the following, all new varieties, of last season, raised by Messrs. HOYLE, FOSTER, and DOBSON. The Collection may be had for £3 15s. Any 12 for 50s, or left to our selection, for 44s.

s. d.		s. d.		s. d.	
Ariadne (Foster).....	5 0	Enchantress (Foster)	5 0	Magnet (Hoyle).....	7 6
Ambassador (Dobson)....	3 6	Exhibitor (Beck).....	3 6	Mochanna (Hoyle).....	3 6
Arethusa (Dobson).....	3 6	Ganymede (Hoyle).....	5 0	Monteith (Foster).....	3 6
Chieftain (Hoyle).....	3 6	Gem (Dobson).....	3 6	Painter Improved (Beck)...	3 6
Colonel of the Buffs (Hoyle)	5 0	Herald (Hoyle).....	3 6	Purple Standard (Foster)...	5 0
Commissioner (Beck)....	3 6	Incomparable (Dobson) ..	3 6	Rubens (Foster).....	3 6
Elise (Hoyle).....	5 0	Lavinia (Foster).....	3 6	Shylock (Foster).....	5 0

NEW FANCY GERANIUMS, raised by **AMBROSE, AYRES, and HENDERSON**, the 12 varieties for £2 2s.

Ambassador (Henderson)...	3 6	Captivation (Ambrose) ..	5 0	Othello (Henderson).....	3 6
Beauty of St. John's Wood (Henderson).....	3 6	Elcetra (Ayres).....	2 6	Princess Royal (Henderson).....	3 6
Caliban (Ayres).....	5 0	Formosissima (Ayres).....	5 0	son).....	3 6
		Gipsy Queen (Ayres).....	5 0	Richard Cobden (Ambrose) 5 0	
		Miranda (Ayres).....	5 0	Superna (Ambrose).....	5 0

NEW SCARLET AND PINK-FLOWERING HORSE-SHOE-LEAVED GERANIUMS.

Amazon (Low).....	2 6	Mountain of Light (Lee).....	3 6
Defiance (A. Henderson).....	2 6	Odoratissima grandiflorum (Henderson) ..	2 6
Hendersonii (Henderson).....	2 6	Shrubland Pet (Henderson).....	3 6

CHRYSANTHEMUMS, fine bushy plants, well set, with flower-buds.

60 Splendid New and Select Varieties, Large-flowering and Lilliputienne, for...	2 0 0
40 ditto ditto ditto ditto	1 10 0
25 ditto ditto ditto ditto	0 17 6

Fine Selections, 5s, 7s 6, and 9s per dozen.

For Varieties of Previous Introduction, see Catalogue. Our Annual Importation of Dutch Bulbs has arrived in excellent condition. We also beg to call attention to our very superb collections of Ranunculi, Gladioli, Iris, and an extensive stock of other roots.

Post-office Orders payable to **STEPHEN BROWN**, Seed and Horticultural Establishment, Sudbury, Suffolk.

HORTICULTURAL BUILDING AND HEATING BY HOT WATER.

Warranted best Materials and Workmanship, at the lowest possible prices.

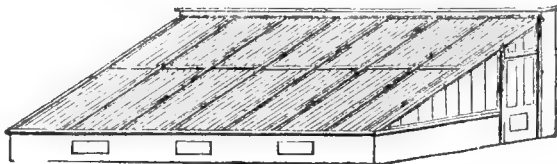

J. WEEKS & Co., King's Road, Chelsea, Horticultural Architects, Hothouse Builders, and Hot-water Apparatus Manufacturers. The Nobility and Gentry about to erect Horticultural Buildings, or the Hot-water Apparatus, will find at our Hothouse Works, King's Road, Chelsea, an extensive

variety of Hothouses, Greenhouses, Conservatories, Pits, &c., erected, and in full operation, combining all modern improvements, so that a lady or gentleman can select the description of House best adapted for every required purpose. The Hot-water Apparatuses (which are efficient and economical), are particularly worthy of attention, and are erected in all the Houses, Pits, &c., for both Top and Bottom Heat, and in constant operation in the Stoves. The splendid collection of Stove and Greenhouse Plants are in the highest state of cultivation, and for sale at very low prices. Also, a fine collection of strong Grape Vines in pots from eyes, all the best sorts. Plans, Models, and Estimates of Horticultural Buildings; also, Catalogues of Plants, Vines, Seeds, &c., forwarded on application.

J. WEEKS & Co., King's Road, Chelsea, London.

TEAS ARE LOWER IN PRICE.—The Stock of Tea in England being nearly ten million pounds more than at this time last year, prices have, in consequence, given way, and enables us to sell really good Teas at very low prices.

The Congou Tea at 3s 4d per pound, and the Hyson Gunpowder at 4s per pound, make an excellent Mixture for general use, while the fine, rich Soucheong Tea at 4s, and the rare choice Gunpowder at 5s, are so really good and truly cheap, that we confidently recommend them to all who desire very superior tea.

We are also selling pure Jamaica Coffee at 1s per pound, and the best Mocha Coffee at 1s 4d. Tea or Coffee to the value of 40s sent carriage free to any part of England, by **PHILLIPS AND COMPANY**, Tea Merchants, 8, King William Street, City, London.

*** A GENERAL PRICE CURRENT SENT POST FREE ON APPLICATION.

THE ONLY STOVE WITHOUT A FLUE, for which Her Majesty's Royal Letters Patent have been granted.

Prospectuses, with Drawings, forwarded free.



Plain, 12s to 25s. Ornamental, 31s 6d to £6 6s.
Stands for Stoves, 2s 6d, 3s, and 5s, each.



CAUTION.—An Injunction having been granted by the Vice Chancellor in the case of "NASH v. CARMAN," restraining the Defendant from making or selling any colourable imitations of the Plaintiff's Stove or Fuel, the Public is respectfully informed that the "JOYCE'S PATENT STOVE," "WITHOUT A FLUE," and the "PATENT PREPARED FUEL," can only be obtained from the Proprietor or his authorized Agents. Every genuine Stove has the Proprietor's name and address on a brass-plate on the front:—

"**SWAN NASH, 253, Oxford Street, London.**"

JOYCE'S PATENT, for warming Halls, Passages, Harness-rooms, Greenhouses, Water-closets, &c., &c. The above Stoves do not emit smoke or unpleasant smell, and will burn without attention or replenishing from 12 to 48 hours. In use daily at the Sole Proprietor's, **SWAN NASH'S**, Ironmonger, 253, Oxford Street, and at the Depot (City), 119, Newgate Street, London; and to be had from the principal Ironmongers in Town and Country.

PATENT PREPARED FUEL, 2s 6d per bushel, only genuine with the Proprietor's name and seal on the sack. **SWAN NASH, 253, Oxford Street, and 119, NEWGATE STREET.**

N.B.—Sole Maker of the **PORTABLE VAPOUR-BATH**, for Families and Travellers, &c., &c., as recommended by the Faculty, complete with large Cloak, £1 11s 6d. **SYPHON AIR-VENT BEER AND WINE TAPS**, 3s 6d; electro-silvered, 5s 6d.

WEEKLY CALENDAR.

M D	W D	OCTOBER 21—27, 1852.	WEATHER NEAR LONDON IN 1851.				Sun Rises.	Sun Sets.	Moon R. & S.	Moon's Age.	Clock bef. Sun.	Day of Year.
			Barometer.	Thermo.	Wind.	Rain in In.						
21	TH	Sun's declination, 10° 52' s.	30.076 — 29.993	62—52	E.	—	37 a. 6	53 a. 4	morn.	8	15 20	295
22	F	Coddy-moddy Gull inland.	30.137 — 29.986	56—50	N.	—	39	51	0 3	9	15 29	296
23	S	Wood Pigeon comes.	30.255 — 33.219	57—50	S.E.	—	40	49	1 14	10	15 37	297
24	SUN	20 SUNDAY AFTER TRINITY.	30.361 — 30.272	57—37	N.E.	—	42	47	2 24	11	15 44	298
25	M	Short-eared Owl comes.	30.386 — 30.348	55—49	N.E.	—	44	45	3 32	12	15 51	299
26	TU	Whitethorn leaves fall.	30.214 — 30.099	57—42	E.	—	46	43	4 39	13	15 57	300
27	W	Tortoise buries.	30.170 — 30.084	59—37	N.W.	—	47	41	rises.	14	16 2	301

METEOROLOGY OF THE WEEK.—At Chiswick, from observations during the last twenty-five years, the average highest and lowest temperatures of these days are 56.3° and 40.1° respectively. The greatest heat, 73°, occurred on the 21st in 1830; and the lowest cold, 20°, on the 21st in 1842. During the period 90 days were fine, and on 95 rain fell.

ROUGH-LEAVED COMMELIN.

(*Commelina scabra*.)



THIS is one of an old genus of herbaceous plants, natives of different countries, some of them requiring the heat

of a stove, others the shelter of a greenhouse, while a third section withstand the rigour of our winters. All of them have fleshy roots or rhizomes, and they belong to the natural order, Spiderworts, the genus *Tradescantia* being the next of the order which is best known to cultivators. They fill up a transition point between the sedges and sedge-like plants, as Xyrids, on the one hand, and the Lilyworts on the other. The genus was named in honour of J. and G. Commelin, two Dutch botanists, by Dillenius, a celebrated professor of botany at Oxford, after whom Linnæus named the genus *Dillenia*. The subject of this biography was introduced from Mexico by Mr. Allardt, of Berlin. It is a half-hardy perennial, and a good figure of it is given in *Paxton's Flower Garden*, iii. 8. *Stems* in a tuft, milky-green, tinged with red. *Leaves* stalkless, sheathing the stems, spear-head-shaped, stiff, horny at the edge, wavy, milky-green, covered with rough elevations. *Flower-sheath* heart-shaped, downy, enclosing from five to ten flowers. *Petals* dull purplish-brown. The genus is included in Triandria Monogynia, class and order of Linnæus. B. J.

Culture and Propagation.—These *Commelinas* are not much in favour among gardeners of the present day, but I recollect the time when as much care was taken of them as is now given to the Dahlias. As soon as the frost cut down the stems, we housed the roots, which grow after the manner of Asparagus, along with those of the Marvel of Peru, Dahlias, Carrots, Parsnips, and Beet-root, in dry sand, away from the frost. In the spring, say in April, they were replanted in light, rich earth in the mixed borders, and if we wanted to increase them, that was effected by dividing the roots as you would a Dahlia, taking an eye or eyes along with each portion of roots. D. BEATON.

A CORRESPONDENT asks us whether we think "the Black Violets (*Nigræ violæ*.—Eclogue, x. 39), the Soft Violet (*Viola mollis*.—Eclogue, v. 38), and the Pale Violets (*Violas pallentes*.—Eclogue, ii. 47), mentioned by Virgil, refer exclusively to our Common Violet?" Without entering into any classical disquisition, or quoting parallel passages from Pliny, Horace, Columella, &c., we reply generally that we believe the references are to one and the same flower, and that that flower is our Common Sweet-scented Violet (*Viola odorata*). "Dark" is quite as faithful a translation of *niger* as "black;" when the Violet is spoken of as "soft," it is in contrast to the thistle, and other armed plants; and the Pale Violets are quite in unison with our White variety. The same correspondent asks if "our Double Violets are recent results of our floricultural skill?" and we will give a reply in the words of old Gerarde, who wrote in 1597—"The Double Garden Violet hath leaves, creeping branches and roots, like the Garden Single Violet; differing in that this sort bringeth forth most beautiful sweet double flowers.—Violets called the Black or Purple Violets, or March Violets of the garden, have a

great prerogative above others, not only because the mind conceiveth a certain pleasure and recreation by smelling and handling of those most odoriferous flowers, but also for that very many by these Violets receive ornament and comely grace; for there be made of them garlands for the head, nosegays, and poesies, which are delightful to look on and pleasant to smell to, speaking nothing of their appropriate virtues; yea, gardens themselves receive by these the greatest ornament of all, chiefest beauty, and most gallant grace; and the recreation of the mind which is taken thereby cannot but be very good and honest: for they admonish and stir up a man to that which is comely and honest; for flowers, through their beauty, variety of colour, and exquisite form, do bring to a liberal and gentle manly mind the remembrance of honesty, comeliness, and all kinds of virtues. It would be an unseemly and filthy thing (as a certain wise man hath said) for him that doth look upon and handle fair and beautiful things, and who frequenteth in fair and beautiful places, to have his mind not fair, but filthy and deformed." Gerarde was a sober and ancient herbalist when he thus wrote, and

we might readily believe, even did we not know the flower, that the Violet must have extraordinary charms, when it could thus excite sedateness to be eloquent.

We shall have occasion to dwell more fully upon the admitted virtues of the Violet when we come to it in due course among the "British Wild Flowers," but we must extract here one note from Willsford's "Secrets of Nature," which says, "When *Violets* flourish in autumn, it is an evil sign of an insuing plague the year following, or some pestiferous disease." If this be so, then will 1853 be a year memorable for its pestilence, for we have before us, October 12th, bouquets and growing plants of the most highly-scented and largest *Violets* we have ever looked upon. These are Shackell's *Russian Superb Violets*; they are treble the size, and far more fragrant than the common Russian Violet similarly cultivated, and though their leaves are also very large, yet the stalks of the flowers are so long and stout, as to render them very conspicuous. Mr. Shackell has a large stock of every description of *Violets*, and intends to sell them at such low prices as to be within the command of all classes. He will, before long, publicly announce his charges. Even Tree *Violets* will be sold very cheap.

FORSYTH MSS.

At page 185 of our 5th volume we gave a biographical sketch of SIR JAMES EDWARD SMITH, the first President of the Linnæan Society, and author of *The English Flora*, and other standard works. The following letter is dated Norwich, September 25th, 1802.

SIR J. E. SMITH TO MR. FORSYTH.

No cause less powerful than the real one should have kept me so long without thanking you for your kind and valuable present of your work, which I now most heartily do. When I received it, I was just beginning to be ill with a fever of violent erysipelas, which detained me a fortnight at Hendon; and then, after my journey home, I was for many weeks unable to look at anything, and in great pain. My complaint is not yet quite gone, but I begin to use my eyes moderately. Your book is in great request here, as it deserves. Mr. Crowe has one copy for his gardener, another for himself, as he makes it his constant study. I have no doubt the general practice of your directions about trees will be of the greatest public use and benefit.

Mr. Crowe and I have again this year been hard at work upon British Willows. Our certain species are about forty. Would it be interesting to you to have cuttings sent you in the winter of all our species, marked with my names? I should be very glad of this, or any other opportunity, of shewing you how much I am, dear Sir, your obliged and faithful friend,

J. E. SMITH.

It may be as well to explain to the non-botanical reader, that the genus *Salix* includes the British Willows, and, in all, about two-hundred-and-twenty-two species, varying in locality from the *Salix arctica*, the last woody plant that lingers in existence as we approach the north pole, to the *Salix Babylonica*, which is found not only "by the waters of Babylon," but in China, Japan, and Northern Africa. These numerous species have been, and still are, the opprobrium of botanists. No one laboured more successfully to arrange them than did Sir J. E. Smith, and his friend Mr. Crowe, until since his death, M. Koch, a German botanist, has

bestowed upon them an amount of knowledge and deep investigation which has left little to be desired.

COVENT GARDEN.

How deep-seated evil practices become! It is upwards of a hundred years since an old writer cautioned the public of that day against the sellers of *Elder berries* and *Elder juice* in Covent-Garden; and it is sad that we should have occasion to do the same now. For a week or two past these commodities have been exposed for sale in considerable quantities. Of the former we need make no remarks, as it is hardly possible that any one could be led astray in the choice of berries, provided they made use of common observation; but against what is sold as *Elder juice* we would have them be especially careful. This article is generally exposed in tubs, and mixed with a large proportion of berries and stalks; but even to a casual observer, the berries show no proportion to the liquor, a great part of which is, in fact, water. "Thus," says the writer above alluded to, "wines and syrups made from *Elder berries* may prove defective, and discourage persons from making a second attempt, by the measure of water with the *Elder juice*, or from blighting causes, or its being expressed from unripe berries." We have thought it our duty to put our readers on their guard against such practices, and would recommend them in all cases, when *Elder wine* is the ultimatum, to provide themselves with sound and well-ripened berries only.

In the fruit-market the supplies have been large during the past week, and the demand little short of what we reported in our last. Everything maintained fully as good prices, and there is every probability they will continue to do so. *APPLES*, it is generally believed, are a short crop throughout those parts from which "The Garden" supply is generally derived, and I am aware of some cases where salesmen have advised their employers to hold, as there is every probability there will be a considerable rise as the season advances. The varieties which have been most plentiful during the week, besides those which we have noticed in former reports, are *Beauty of Kent*—a beauty, indeed, but this season they are very much deformed, having almost entirely lost their conical shape, and become somewhat flattened and angular; they still, however, retain their beauty of colouring and russety base. This must not be confused with the *Flower of Kent*, under which name it is often met with in the market. Though both are good apples, still the former is by far the better one of the two. It is one of the most magnificent apples we know, when grown to perfection, and is one of the best autumn baking varieties. *Emperor Alexander*, of which we made mention last week, is in still. It is like a great many more things in the world, more for show than for use; and I would, therefore, never recommend any one who has only a limited extent of ground to think of growing it. *PEARS* are plentiful, and of all qualities, many of them being, as the costermongers call them, "fine mellow pears." However these may have

done a hundred years ago, they will not do now by the side of *Beurre Bose*, *Duchesse d'Angoulême*, and *Jersey Gratioli*, all of which are now to be had in quantity. The latter is a most delicious, rich, and sprightly flavoured fruit. It possesses that peculiar briskness which is only to be found in a pine-apple, and which one is loathe to call acid; and at the same time is rich and sugary. This is a variety which can be "highly recommended," and which ought certainly to find a place in every garden. PLUMS are going out, and we have nothing new to notice besides what we have treated of in former reports; there are still, however, some arrivals of foreign baking varieties, of what the Germans call *Quetsche* family. The GRAPES continue the same as last week, being chiefly *Black Hamburgs* and *Cannon Hall Muscats*. There has been a large arrival during the week of foreign Black Hamburgs in baskets, in excellent condition, which fetched from 1s. to 1s. 3d. per lb. There are still some late PEACHES to be met with in the first-class fruiterers', but the few remaining NECTARINES there are do not seem very tempting. PINES are plentiful for the demand, and make from 3s. 6d. to 6s. per lb.

In the vegetable department there has been a plentiful supply. CABBAGES make from 6s. to 7s. per dozen, according to the size and quality. The variety which is most extensively grown for the London markets is the *Battersea*, which is also known in the country by many names, such as "Fulham," "Barnes," "Emperor," and "London Market." CAULIFLOWERS are excellent, and vary in price from 1s. to 2s. 6d. per dozen. BRUSSELS SPROUTS have come in, and are to be had at from 1s. 6d. to 2s. per half-sieve. FRENCH BEANS are less plentiful, and are, consequently, making more money. Some weeks ago they could not be sold at any price, but now they are making from 2s. to 2s. 6d. CELERY is very fine; the best can be had at 1s. 3d. per bundle. TURNIPS from 2s. to 2s. 6d. per dozen bunches; and CARROTS 2s. 6d. to 4s. per dozen bunches. POTATOES are on the rise, and likely to continue so; they make from £3 to £6 per ton; the finest are the *Regents*, which are in excellent condition, and make from 3s. 6d. to 4s. per bushel. MUSHROOMS still continue plentiful, at last week's quotations. H.

GOSSIP.

AMONG the very numerous charities at Winchester is *The Natives' Society*, for the apprenticing of the children of poor citizens. It was founded in 1669, but we only notice it for the purpose of quoting some of the prices paid for articles connected with the Society's annual festival in the days of yore.

"1675.—Paid for 9 bushells of malt and grinding £1 6 0
Paid for halfe a bushell of barley for the
poultry - - - - - 0 1 0
"1676.—For lemonds, 4d. For aples, 2s. For cabidge and
cariot, 1s. 6d. For 4 bushells of wheat, 12s. 6d."

At the *Yarmouth Poultry Show*, Miss E. Watts took a first prize for dark-coloured Cochinchina Chickens, and not a second prize, as stated in p. 418 of our last volume.

There is a brilliancy—a glory—around the fall of the warrior on the field of victory that takes away much from the mournfulness of death. We think we are not wrong in saying that there are few so base as to shrink from facing that death with a firm onward foot, and an unquailing heart, amid the ranks of comrades, and all the excitement and panoply of war. This is courage; but it is courage which excitement would infuse into a poltroon. There is another courage which we consider more admirable, though less appreciated—we mean that of the dying student, who, suffering under the slow inroads of an incurable disease, still labours on in the quiet retirement of his library, intent to fulfil his allotted task, though well assured that death's foot is far advanced across his threshold. This is passive courage—this is genuine heroism—and never was it more forcibly displayed than by DR. WILLIAM MACGILLIVRAY, late Professor of Natural Philosophy in the University of Aberdeen. The two concluding volumes of his *History of British Birds* have just been published, and these are the contents of their concluding page:—

"Commenced in hope, and carried on with zeal, though ended in sorrow and sickness, I can look upon my work without much regard to the opinions which contemporary writers may form of it, assured that what is useful in it will not be forgotten, and knowing that already it has had a beneficial effect on many of the present, and will more powerfully influence the next generation of our home-ornithologists. I had been led to think that I had occasionally been somewhat rude, or at least blunt, in my criticisms; but I do not perceive wherein I have much erred in that respect, and I feel no inclination to apologise. I have been honest and sincere in my endeavours to promote the truth. With death, apparently not distant, before my eyes, I am pleased to think that I have not countenanced error, through fear of favour. Neither have I in any case modified my sentiments so as to endeavour thereby to conceal or palliate my faults. Though I might have accomplished more, I am thankful for having been permitted to add very considerably to the knowledge previously obtained of a very pleasant subject. If I have not very frequently indulged in reflections on the power, wisdom, and goodness of God, as suggested by even my imperfect understanding of His wonderful works, it is not because I have not ever been sensible of the relation between the Creator and His creatures, nor because my chief enjoyment when wandering among the hills and valleys, exploring the rugged shores of the ocean, or searching the cultivated fields, has not been in the sense of His presence. "To Him who alone doeth great wonders," be all glory and praise. Reader, farewell."

Death, indeed, was "not distant" when Doctor Macgillivray penned those thoughts on the last day of July, for in little more than six weeks he was within his grave. The opinion he had of the work of his dying years, for it occupied twelve, was not too high. We have perused it thoroughly, and we rose from it with the conviction that it is the best work existing on British Ornithology. It is the best for all the reasons that render such a book valuable—for its descriptions are most full and most accurate—its anatomical demonstrations more perfect than any previously effected—and the habits, haunts, and associations of each bird are most pleasingly described, not only with all the freshness induced by personal examination, but with all the spirit of a genuine lover of nature. We have room only for this short description of the habits of the *Red-breasted Goosander*:—

"In the outer Hebrides, in March, April, and part of

May, and again in autumn, I have seen very large flocks in the small sandy bays, fishing day after day for sand-eels. They sit in the water much in the manner of the Cormorants, but without sinking so deep, unless when alarmed, and advance with great speed. It is a pleasant occupation to an idle scholar or wandering ornithologist to watch one of these flocks as it sweeps along the shores. I have many times engaged in it, both with the desire of shooting some of them, and of studying their manners, which are very graceful. You may suppose us to be jammed into the crack of a rock, with our hats off, and we peeping cunningly at the advanced guard of the squadron, which is rounding the point at no great distance. There they glide along, and now, coming into shallow water, they poke their heads into it, raise them, and seem to look around, lest some masked battery should open upon them unawares. Now one has plunged with a jerk, another, one here, one there, at length the whole flock. Now start up, and if you wish a shot, run to the water's edge, and get down among the sea-weed behind a stone, while I from this eminence survey the submerged flock. How smartly they shoot along under the water, with partially outspread wings, some darting right forward, others wheeling or winding, most of them close to the sandy bottom, but a few near the surface. Some flounders, startled by the hurricane, shoot right out to sea, without being pursued. But there, one is up, another, and I must sink to repose in some hole. How prettily they rise to the surface, one here, another there, a whole covey at once emerging, and all without the least noise or splutter. But they are far beyond shot range. However, having come near the next rocky point, they now turn, dive in succession, and will scour the little bay until arising here at hand they will be liable to receive a salute that will astonish them. A whole minute has elapsed, half another; but now one appears, two, many, the whole flock; and into the midst of them pours the duck-shot, while the noise of the explosion seems to roll along the hill-side. In a twinkling all are down, save six that float on the water, four dead, one spinning round, and the other striving in vain to dive. In less than two minutes they are seen emerging, more than a quarter of a mile out at sea, and presently again they are out of sight. On such occasions they seldom fly."

A correspondent writing to us from Inverness, says:—

"An immense breadth of *Potatoes* is planted here, (chiefly Irish cups); about one-half of the produce is destroyed by the disease, and it is astonishing to me with what cool indifference her Majesty's subjects allow them to remain in the ground to rot! For the life of me I cannot understand this apathy for the potatoes.

"The harvest is completed in first-rate order, and the produce generally abundant. The *Turnip* crops are splendid, with very few exceptions, and some mildew.

"What capital farming, generally speaking, we meet with in Scotland; I admire the quiet method of their proceedings, but the women are worked too hard."

We hear that the first-class collection of *Cochin-China* fowls formed by Mr. Andrews, of Dorchester, have been sold by him to Mr. Cattlin, of London, for £250. We hope Mr. Andrews will address himself to raising a fresh yard of them.

The *Cornwall Society's Exhibition of Poultry*, as stated in our advertisement columns, is fixed for the 10th and 11th of January, 1853. Its premiums, considering that it must, from difficulty of access, be comparatively local, are liberal, and its rules good—so good, that several of them have been adopted by the Winchester and Southern Counties Society for the improvement of Poultry. We have no doubt as to the show being good, for the published accounts of the poultry-yards near Penzance shew that they have first-rate birds in its vicinity. We hope soon to publish extracts from those accounts.

The following is a list of the *Horticultural and Poultry Shows* of which we are at present aware. We shall be obliged by any of our readers sending us additions to the list, and giving the address of the Secretaries.

HORTICULTURAL SHOWS.

- BURY ST. EDMUNDS, Nov. 26 (Chrysanthemums). (*Sec.* G. P. Clay, Esq.)
 CALEDONIAN (Inverleith Row), Edinburgh, Dec. 2.
 HAMPSHIRE, Nov. 18 (Winchester). (*Sec.* Rev. F. Wickham, Winchester.)
 LONDON FLORICULTURAL (Exeter Hall, Strand), Nov. 9+, 23, Dec. 14+.
 NORTH LONDON, Nov. 23, Chrysanthemum.
 SOUTH LONDON (ROYAL), Nov. 11+, Dec. 9+, 16.

POULTRY SHOWS.

- BIRMINGHAM AND MIDLAND COUNTIES, 14th, 15th, 16th, and 17th December.
 BRISTOL AGRICULTURAL, December 7th, 8th, and 9th. (*Sec.* James Marmont.)
 CORNWALL (PENZANCE), January 10th, and 11th. (*Secs.* Rev. W. W. Wingfield, Gulval Vicarage, and E. H. Rodd, Esq.)
 DORCHESTER, Nov. 18th. (*Sec.*, G. J. Andrews, Esq., Dorchester.)

† For seedlings only.

FRUIT STORES.

WE must break in on the series of Pine papers for a week, in order to offer advice on this head. As to gathering, of course much of that will have been performed. The gathering, however, is pretty well understood; and the amount of care requisite tolerably well appreciated. Some of our late pears will be still out in places, such as the Winter Neils, the Glout Morceau, Beurré d'Arenberg, Beurré Rance, Ne plus Meuris, and some of Mr. Rivers's new continental kinds, of which, as far as tried, we cannot speak very highly in the north; in the southern portions of the kingdom they may deserve a very high character. We are no advocates for letting the fruit remain long enough on the trees to endure several degrees of frost. A thermometer of 28° may, perhaps, do no harm, but lower we would never go if we could avoid it. Indeed, after the first week of October, it is probable fruits receive but little benefit from the tree: that they may receive harm is certain. The juices of the tree become very sluggish after that period, and the elaborative functions of the foliage almost a nominal affair, as far as the fruit is concerned, and this more especially with regard to fruits from warmer climates. And now a few words as to the keeping of our valuable winter apples and pears, about which some difference of opinion still exists. It is evident that the main principles we have to consider in this question are as follows—

The temperature.

The hygrometric conditions.

The action of the atmosphere.

Beyond this, we think nothing of any weight pertains to the question; whether they lie on straw, fern, or paper, or on the mere boards, or on any other material, matters little, only as far as they contribute to the carrying-out the necessary conditions, or of saving the fruit from bruises.

As to temperature, there is little doubt that coolness, or that amount of cold which would be unpleasant to endure sitting in a room, is absolutely essential to the long keeping of fruits. But whilst this is observed, let it not be supposed that a single degree of frost may be permitted. Whatever injury it may do the fruit whilst in a growing state on the tree, there is little doubt that much more injury accrues from such conditions when in a transition state from firmness to mellowness.

Some very peculiar changes of a chemical character are well-known to be requisite, and to take place, unless arrested during the ripening process; the chief arrest being, we imagine, occasioned by sudden and injurious depressions of temperature. Some of our best pears will become, under such circumstances, like petrifications, and totally insipid. What has been termed "bletting," that is a sweet-tasted decay, as in the *Medlar*, is probably thus caused, and, indeed, other evils; this at once points to the propriety of being enabled to remove them, when necessary, to a room where a temperature of 50° to 60° can be sustained at any time. Now, we should scarcely think it necessary to fix a heating apparatus in the general store-room; there should be a special room for this purpose in all gardens of any consideration. The grudging little outlays for this purpose belongs, we would hope, to bygone days; for the apothegm "what is worth doing, is worth doing well," gathers strength every day, and has long since invaded the precincts of the garden. In planning new fruit-rooms, we would, from a door at one end of the store-room, enter a little snug box, having a heating apparatus of hot water, the boiler outside, and the interior fitted with a few shelves on one side, and a few receptacles, or nests for shelves, on the other, with a small bench for operations. These shelves would be useful in containing those fruits which, at all periods require a higher temperature, as, indeed, all fruits for immediate consumption would do unless quite ripe. The nests, or receptacles, should be a counterpart of a similar set in the general store-room; and these two rooms would have to exchange fruits very frequently: those ripe and to be retarded moved from the warm room to the cold one, and *vice versâ*. We are here, as in duty bound, setting forth a somewhat high course of practice; not high through complicated machinery or mighty expense, but involving a little trouble, attention—perseverance, if you will. Those who can afford to do such things, and who turn back in dread, we must pass by for the present. It is no part of the duties of those who attempt to advise in these times to affect a very low standard, carrying a specious appearance of economy outside, but penny wise and pound foolish within. We are aware that not all small gardeners can do these things; still it is well to lead even these to a consideration of principles, and of the ultimatum to which everything in the present condition of society has a tendency.

To resume, then, the course of the subject; having spoken of the warm or ripening room, let us think of the character of the general store-room. This, of course, should be much more capacious; whatever the size of the establishment, we should say as six to two. Here would be permanent shelves for those ordinary kitchen apples, common pears, &c., which, once housed, would not require to be removed. On the other hand, there might be sets of drawers, or trays, of a moveable character, exactly fitting the set of nests or receptacles before described in the warm room, so that one or more might be moved at any time with facility. Thus, then, to put a case: we will say this October the 4th we want to retard some *Delice d'Hardenpont* pears, and to hasten some *Marie Louise*; we will then take No. 1 in the warm room, containing the *Delice*, to No. 1 in cool room, containing some *Marie Louise*, and "ring the changes." Again, No. 15 in warm room is a tray of greengages from a north wall, now perfectly mellow; they must be "cooled down." Let us exchange them for No. 8 tray in the cool room, which contains *Ribston Pippins*, and which will be required in a mellow state for some large parties, who are pheasant shooting in the middle of the month. As before observed, these trays must be made to fit the respective nests with ease; this done, the transit is accomplished without the least detriment to the fruit.

About the modes of heating, &c., we have not space for an observation; such may stand over to the long winter evenings, which approach with giant strides.

We pass on to the hygrometric conditions, our second postulate; the amount of moisture permissible or desirable in the air of the fruit-room. This is a somewhat puzzling part of the question, inasmuch as authorities of high standing, and too respectable to be totally set aside, may be found, who throw their bias sometimes into one scale, sometimes into the other. There can be little doubt, we think, that the epidermis (skin) in fruits acts by transpiration, and that such transpirations is, in a degree, arrested by a somewhat damp condition of air; albeit, as we think, at the expense of flavour and mellowness in fruits. However, in this matter, we ought to distinguish carefully; to keep late apples from shrivelling, and to preserve such things as delicate-skinned pears, plums, melons, cherries, &c., are two very different affairs.

With regard to the varying conditions necessary, and the crisis which occurs from the gathering of the fruit to its consumption, much may be said. Mr. Knight, of Downton, made the following remarks:—"Fruits which have been grown on standard trees in climates sufficiently warm and favourable to bring them to maturity, are generally more firm in their texture and more saccharine, and, therefore, more capable of being long preserved sound than such as have been produced by wall trees; and a dry and warm atmosphere also operates very favourably to the preservation of fruits under certain circumstances, but, under other circumstances, very injuriously; for the action of those elective attractions which occasion the decay and decomposition of fruits, is suspended by the operation of different causes in different fruits, and even in the same fruit in different states of maturity. When a grape is growing upon the vine, and until it has attained perfect maturity, it is obviously a living body, and its preservation is dependent upon the powers of life; but when the same fruit is sometimes past its state of perfect maturity, and has begun to shrivel, the powers of life are no longer, or, at most, very feeble in action, and the fruit appears then to be preserved by the combined operation of its cellular texture, the antiseptic powers of the saccharine substances it contains, and by the exclusion of air by the external skin, for if that be destroyed it immediately perishes. If longer retained in a dry and warm temperature, the grape becomes gradually converted into a raisin, and its component parts are then only held in combination by the ordinary laws of chemistry." Thus far Mr. Knight, whose observations went as far in these matters as any man, backed, at the same time, by the most extensive amount of physical knowledge. Now, we have capital illustrations of the soundness of at least one part of Mr. Knight's theory, especially in the *Marie Louise* pear. This we have growing in all forms—on table trellises, the ordinary espalier, the pyramid, and on east and west aspects, and a noble crop we have. Those on a west aspect have a skin like wax-work; those on the pyramid or table trellis, and exposed to every blast, have a russet coating; and those on the east aspect, about intermediate. Now, this has been the case for several years; every year has produced the same results. And what as to flavour and keeping properties? Why, as might be fairly anticipated, just corresponding with the character of the coating, or nearly so. To be nice over such points, however, there is a very peculiar difference between them on the palate, and, for our own part, we can scarcely tell which to covet; our worthy employer, however, who is as keen a judge as most gentlemen, and has a most extensive knowledge of fruits, seems always to prefer those with waxy skin, from the western aspects; and, indeed, they are larger, perhaps more melting, finer in texture, but

assuredly a lighter flavour, though excellent; but to be fair, those from the standards in our north latitude have a kind of snatch of the wildings in them, which, to some palates, is not disagreeable.

It is to be feared that these observations will appear too digressive, and we must hasten back to the main features of our tale. There can be little doubt that apples, especially the ordinary kitchen kinds, endure and enjoy a greater amount of danger than pears, or, indeed, any thin-skinned fruits. They have been well-preserved in ordinary cellars, nay, in pits, or "hogs," and, indeed, much beyond their ordinary season by such means, but, as before observed, at the expense of flavour. This is, however, another argument for the necessity of two rooms. If we must be compelled to keep a general store of all kinds together, we should prefer a room on the north side of an existing building, the floor about a foot above the ordinary ground level, and the exterior walls double, possessing a cavity of about six or eight inches all round the exterior. In the roof, we would have escapements for damp, to be opened at pleasure, and capable of graduation; and we would have similar openings in front, at two levels—one portion just above the floor, and the other near the top of the room. The admission of light need not be the means of ventilation; windows must be, of course, provided, in order to facilitate, when necessary, any arrangements connected with the fruit. This, however, is but a "lumping" of matters; whilst we write thus, we are perfectly assured that some fruits are the better for a moderate amount of moisture in the air; others the worse; and, as Mr. Knight observed, the same fruit at different periods requires varying conditions, in order to bring out its qualities in the highest perfection.

Want of space prevents our pursuing this interesting disquisition as far as existing facts would warrant, and we must pass on to consider

The Action of the Atmosphere.—We are afraid that in discussing this portion of the question little heed will be paid by some to its importance. There can be little doubt, however, that it is a question worthy of much consideration. As for the first gathering of the fruit, within a couple of weeks after which the fruit undergoes what is termed sweating, a most liberal ventilation is necessary to ordinary fruit. Here, again, the propriety of having two rooms irresistibly forces itself on our notice. But these things accomplished, a moderate course becomes necessary; and, indeed, towards Christmas, rooms in general require to be hermetically sealed, as it were. That the more rapid the current of air that passes over them, the greater the detraction of juices from the skin of the fruit, there can be no doubt; but this would seem to be, in some cases, necessary to produce flavour. However, any stagnation arising from moisture in excess must be dissipated by such means, or by heat; and, as before observed, we would have the ordinary stores kept in a cool condition. Whilst, therefore, the warm room would seldom require much air, the cool or store-room would require at times a liberal amount; all this determinable principally, if not entirely, by the character of the air within as to its amount of moisture.

Light.—This, although not placed amongst the conditions for consideration, is a most important affair; in former days paid little attention to. Now, however, the importance of darkness to fruit is almost universally recognised; and most practical men keep their fruit-room shutters closed. This it was that made us suggest ventilation by other means than the windows, for cases frequently occur when a circulation of air without light is essential. Every body knows that fruit is liable to acquire a tendency to breed those obscure cryptogamic bodies commonly termed "moulds," and that these, however induced, are increased by a damp air, and by light.

These are frequently induced by bruises; but some kinds of fruit show an evident predisposition to the produce of this pest. We have reason to believe that darkness is unfavourable to its spreading, and, if so, is another reason for keeping closed shutters. Although the patience of our readers may be exhausted by so much about fruit-keeping, yet we will not confess to the subject itself being exhausted; enough, however, has been said to set our readers thinking for themselves.

R. ERRINGTON.

SENDING PLANTS TO AUSTRALIA AND ELSEWHERE.

This subject occupied nearly as much of our attention for the last two years, as that about bees and poultry; and no doubt, when the flush of the diggings is over, and people there return to their senses, their cottages, and cottage gardens, we shall have an extended sale for our publication in those quarters, and a new impulse will arise in the trade in plants between the two countries. Until the Isthmus of Panama is smoothed down for steam carriage, it is still the safest way to send plants round Cape Horn for the different ports in Chili and Peru, and the trade from London to those ports, as I shall presently show, is reported from the nurseries, and the last accounts from the Cape of Good Hope bring whisperings of gold stores, where the old Caffir Chiefs will one day or other join issue with General Cathcart himself, and his "burgher levies," in a different game, after casting their swords and spears into the Fish River. Here, then, is another opening, in anticipation, for our nurseries and emigration societies to pour in their accumulated stores, to say nothing of the Indian and China market, upon all of which it is better to keep our eye than to sleep with one eye open. I was at Oxford the other day, where I made a whole budget of university, or rather universal, news about gardening; and having, by mere chance, got into conversation with patrons of THE COTTAGE GARDENER, who were discussing the merits of the different ways of transmitting plants to distant parts, I learned that Mr. Low, of the Clapton Nursery, was in the constant habit of executing orders for Australia, New Zealand, and South America; but to make sure of the point, I returned to London the same evening, all in the dark, for the people of the "Great Western" do not provide lights for their second-class passengers like the South Western Company, in whose carriages you could read the small print edition of Uncle Tom's Cabin any night in the week. I was in Clapton just in time to see a large case of plants packed for New Zealand, and another one in progress for Valparaiso. I also saw two more orders, one for Brazil and another for the West Indies. The latter is to be sent out on Ward's plan, and the case is to be returned with bread-fruit trees and others that are scarce in the trade. What was better than all, the packer is an old play-fellow of mine, Mr. McDonald, a well-known gardener of great experience and skill; and, as a matter of course, he made no secret of his way of packing, which is so sure and effectual, that large orders are sent to Mr. Low from the most distant parts, through no other interest than the celebrity of his packers. Indeed, a letter was pointed out to me in proof of this, from the same British resident in Valparaiso to whom the present consignment is to be sent, in which he states that the last plants he had from Clapton arrived in as good health as when they left Clapton, and that some of the Rhododendrons and Camellias were in full blossom when he unpacked them.

From the end of September to about Christmas, Mr. Low thinks is the best time to pack plants for such long journeys; but he has packed in all seasons. The case

that I saw packed for New Zealand is going out with a reverend gentleman (Mr. Baily), who is going on a visit to Taranaki. It was four feet six inches long, nearly two feet deep, and as much in width, of strong one-inch deal; one-half of the plants were packed with the roots in the packing materials, placed against one end of the case, the other half at the other end, and thus their heads met in the middle of the case free from any packing-stuff. I was told that a few holes were to be made on either side of the case in the middle, to let off any damp or vapour from the leaves or packing stuff, but not so large as to admit a mouse. The whole was nailed down firmly, the case then strongly corded, and the address was painted on the lid; and, as an additional strength, strips of half-inch board were nailed all round the case in the middle, and also at both ends, the cords running close to these strips, so that they could hardly be "chaffed," or worn by the tossings of the vessel in bad weather. The plants were of a mixed character, twenty-four of them being shrubs or trees, and a dozen Pinuses, and other things of which I did not think it worth while to take the names, as none of us know really what is most in demand either in New Zealand or Australia; but I expect soon to get a sight of a very long and interesting letter, written from Australia, in which a great many things are explained respecting the gardening want of the different settlements, as well as the gardening gossip of the day in these parts. This is just what every one that is interested in the subject wants to know.

I copied the following digest from the invoice going out to Valparaiso:—450 *Camellias*, 100 of which to be the old double white; 240 maiden plants of twelve kinds of *Plums*; 25 *Ribes sanguineum*; 12 of the *White Ribes*, a variety of *Sanguineum*; 100 newest *Dahlias*; 6 *Stanwick Nectarines*, and 50 *Daphne indica rubra*, together with a host of single plants, many of which, I could vouch for it, were culled from the pages of THE COTTAGE GARDENER. Our friends in South America thus seem to have as much confidence in our recommendations as their brethren in the United States, who, as Mr. Brint, of Philadelphia, told me last July, have the fullest confidence in whatever appears in our pages about new plants. How lenient, therefore, ought our home correspondents to treat our hesitations about getting up lists of such-and-such plants on the spur of the moment, when we have such a weight of responsibility, that ought to be most conscientiously discharged for the good of all parties.

The principle of the mode of packing adopted in this nursery is that which I have all along recommended, but the application of it is different. First of all, the plants are well watered, so as to have every part of the balls wetted through and through; they are then put aside to allow sufficient time for draining off the superfluous moisture. Meantime, a quantity of moss from Epping Forest is thus prepared:—Take a large tub, and pour a potful of water into it, then put in as much of good sandy loam as will form the whole into a thick puddle, or paint; now throw in a quantity of moss, and work it with the puddle, taking care to have every particle of the moss smeared with the compost; with this daubed moss cover each bulb half-an-inch thick, and fasten it round with strings of fresh matting, or small twine. When the whole are thus finished, begin to pack, by placing an inch of perfectly dry moss on the bottom of the case, at one end; on this place a row of the balls on their sides, with the bottom of the balls facing the end of the case, with another inch of dry moss intervening between the balls and that end. The balls being round, there will be little empty spaces between them at top and bottom; these spaces must be filled up with more daubed moss. We have now one layer of plants with their heads lying towards the

middle of the case, a bed of dry moss under and behind the balls, but nothing yet in front of the balls, or what was the surface of the pots. Along this front a layer of the dry moss, two inches thick, is very closely packed, and a piece of stout deal, or board, the exact size of the width of the case, is placed closely against this layer, and nailed at both ends from the outside of the case; the next layer of plants is then packed over the first, and pressed down so as to get bedded in the puddled moss, dry moss being placed all round, as with the first layer, and the interstices filled up with the puddled moss; another bar across as before, and so on till that end is filled, finishing with a layer of dry moss, on which the lid rests. Then finish the other end of the box, or case, just in the same way, and when the lid is nailed on let us turn up the case on one end, and see how the whole stands with the mind's eye. The whole mass in the centre, within the dry moss, is in that state we call neither wet nor dry, and so close throughout that no breath of air can get into it. This of itself, in a wooden box, would remain a long time sufficiently damp to keep the plants alive in their dormant state; but see how things would turn as soon as the vessel got within the tropics—even if there was no jolting of the vessel all the time to disturb the puddle, the wood would not be proof altogether against the heat of a vertical sun, and the damp of the moss would, in time, rise in vapour, and smother the leaves, rot the young shoots, and probably destroy every plant long before they reached the latitude of the Cape of Good Hope; but the firm lining of dry moss—and it must be very firm indeed, and so must the whole mass—is found in practice to be quite proof against any dispersion of damp or vapour whatever, as well as being one of the best non-conductors of heat; and, like the proof of the pudding, all this has been proved in a hundred instances, over a great many years, and to all parts of the globe. I dare say Mr. Low, Mr. Veitch, and all the nurserymen who import plants largely from distant parts, could tell of the hundreds of pounds that have been utterly lost to them from bad packing; and no doubt this system has been arrived at bit-by-bit, although they do not like now to rake up these unpleasant recollections, to which I could myself add a mite or two as big as a locust, if it were to any good purpose; so that my hasty return from Oxford, *all in the dark*, to learn a better system, may be the more easily accounted for, although I must go back, *some day* or other, to finish my notes on the interesting things I left unnoticed this time.

As far as I could make out from the explanation of Mr. McDonald, the great packer, loam is better for puddle than clay, as if it should get too dry, it does not bind so hard as clay would do to injure the roots; mixing it with moss gives a double chance, or rather three chances to one in our favour, for it keeps the whole open, as it were, for the roots to work into the puddle, should they be excited in running through the hot part of the journey, and all gardeners know that roots will run along vigorously on the least application of heat, although the branches be leafless, and encrusted in frost or snow:—make a hot-bed over the roots of any of our hardy trees next winter, and prove the fact, if you doubt this. Indeed, although I cannot explain my meaning so as to make it as clear as I should wish it to be, I am almost sure that the turning point in this safe way of packing, is in allowing the roots to extend freely under high pressure, so to speak:—we have all of us seen trees that have been felled in February brought into full leaf by a few April showers, and that accounts for the effect of the small holes in the sides of the packing case, letting off the vapour that might endanger the heads of the confined plants on this voyage. But there is another turning point. As soon as the heat converts

the dampness of this puddle into vapour, the moss in it sucks it up like a sponge, and on getting into cooler quarters, the loam sucks it back from the moss, and so by a system of "give and take," the moisture is retained in the moss for a very long time, much longer than could be expected from either the moss or the loam by itself; at any rate, the effects are now fully known and taken advantage of, whether we can explain them properly or not.

One remark which Mr. McDonald made to me I cannot withhold, as it may be of use in extreme cases. He said that, if this box was placed inside another box that was one inch larger all round, and that inch space filled with charcoal dust, the whole might go to Taranaki and back again with perfect safety to the plants. I also learned that a hundred plants, including fruit-trees, might thus be packed, and sent on board in London, at from 1s. to 1s. 6d. per head.

D. BEATON.

NOTES ON WINDOW-GARDENING.

WITH all the deficiencies that exist in this department, there are great and pleasing signs of progress. Often have I witnessed results that would constitute no inappropriate lesson to the best gardeners among us. These happy effects are never the consequence of what the indolent too often term "a lucky hit," or "a lucky chance." I have no faith in such chances. I look upon the expression, "lucky fellow," as one which ignorance too often trippingly uses for shrouding from itself its own thriftlessness, idleness, and impudence. From the window of the lady's buodoir, to that in the garret of the street apple woman; from the balcony in a suburban retreat, to the smoky leads on the summits of houses in London, I have seen plants beautiful and flourishing; but never as a matter of "luck," but always the consequence of care, cleanliness, and good management, commingled with something of the enthusiastic for all that pertains to vegetation. Nor is this all. Whatever there may be in the strange principles of mesmerism, there can be no question, that the tending of plants from love to them, will always exert a softening and refining influence upon human character. Without that love, plants may be well grown as a matter of speculation and trade, but without it, and no pecuniary object in view, we shall see little of fine gardening in our cottage windows. This becomes a matter of no little moment, if it be true, as we contend it is, that the condition of a garden, and the state of the window plants, form no bad criterion of the tastes and aspirations of those who reside within. Would that Britain's daughters would clearly see how easily youthful swains "might thus take their notes," and read their character.

Our Editor might well say it was difficult to please every one. Some have complained that we devote too little attention to this interesting subject; while others, again, say "You are always dabbling about the windows, as if there were no other place in which to grow and keep plants; can't you present the subject under entirely new features?" There is the difficulty. It is an easy matter to fabricate, or borrow a new idea, and back and ride it right valiantly, heedless of consequences; but, much as we like novelty, we like those things that are practically demonstrated much better, and writing for the *practicals*, truth obliges us to say, that in this window-gardening concern we are really at a standstill for the *novel*. Almost every plant most suitable for window-gardening has been mentioned; the mode of cultivation alluded to; everything connected with economy, taste, suitability to the circumstances, adverted to and elucidated; and I hesitate not to say, that the various papers scattered through the work, if collected and arranged, would constitute the best treatise on the

subject that has ever appeared. Then why allude to the subject now? Many reasons might be given. Let three for the present suffice. Many are now trying their hand who have read but few of these papers. Many say that they have *tried* hard to work according to rule, and yet have not fully succeeded; and many, again, care less for winter display than making their windows repositories for plants to bloom out-of-doors in summer. From what we have been told, and what I have seen, I can clearly see several causes of failure, and these obviated, as many means of success will be secured. We may so far avoid the one, and secure the other, by attending to the following propositions or directions.

First, *House the Plants, or get them under shelter early in October*. In the northern counties temporary protection should be secured by the end of September. Few window-gardeners will content themselves with one set of plants for the season. They best show their knowledge who can have their windows always fresh and gay with successions of plants and bloom. For this purpose many things may be kept out-of-doors during the summer, and in many cases, cuttings taken from flowering plants in spring will beat their sires in autumn. In a warm, dry autumn, the longer the plants stand sheltered in the open air the better. Their stems thus get more thoroughly matured. Some, of course, want more hardening than others. I lately mentioned all the broad sectioned tribe of Cacti-Epiphyllums as being well-suited for window-gardening. Their blooming well in spring and summer depends on the quantity of bright light that plays on their stems during the previous autumn. Clear sunshine, and comparative dryness at the roots, are the things to aim at. A soaking at the roots *now*, would give so much moisture to the stems, that the muggy atmosphere of a whole winter would scarcely evaporate it. A very little frost would also injure the embryo-buds, though as yet next to imperceptible. Geraniums and other things are also injured by both such means. A miserable sickly hue during the whole of the winter is often the result of a few hours frost or sleet in autumn. If circumstances compel you to keep your plants out late, provide a temporary covering that you can throw over them in a moment of emergency. A light shed, an empty room, anywhere, where light and air can be given, will be a more secure place than out-of-doors, after the commencement of this month. Plants, however tender, will stand a great degree of cold, if they are dry.

2ndly, *Shift and pot early, and, as a pre-requisite, strike cuttings early*. Plants, whether old or young, if growing freely, and fresh roots reaching the sides of the pots, will stand rougher treatment, and require far less trouble in winter, than plants whose roots are beginning to move into fresh soil. Every little oversight, such as too much wet or too much dryness, a moist atmosphere or a dry one, a cold air or a warm air, are apt to be injurious to the latter. The poor things resemble a man with several enemies, who has got no wall against which to plant his back,—no firm yet gently-yielding ground on which to rest his feet. The transplanting of a cutting, or the shifting of a plant pretty well established from one pot to another, always is accompanied by a check to the growing principle. Where conveniences exist, we neutralize these as much as possible by close pits and shading, to lessen evaporation, until the roots are again fairly at work, and thus we submit to a present inconvenience in hopes of obtaining a future advantage. But our window-gardeners are, generally, not overburdened with conveniences; and their only chance to have plants in a nice healthy state in winter, is to pot little after the first of September. It is true, many things may be potted now, but they must rather be viewed as reserves for the future than ornaments for the present.

3rdly. *Bulbs, such as Narcissus, Tulips, Hyacinths, Crocus, &c.,* to bloom in winter, or, rather, in windows in spring, should be potted early likewise; and when placed in a cellar, or in a corner of the garden, covered over with ashes or dry earth. The pots may be brought in to the window when the pots are filled with roots, and the leaves and flower-buds appearing. A slight shading will be wanted at first; a paper funnel, the broad end over the pot, and the small end with a hole in it to admit a portion of light, is useful for this purpose, and also for drawing up the flower-stems of Hyacinths, so as to give the florets room to expand.

4thly. *In potting in autumn, use uniformly light, sandy soil, in rather a rough state.* That which may be obtained by the sides of highways, as the accumulations of road-drift and scrapings, *old* and well aired, will grow nineteen-twentieths of the plants usually cultivated in windows. A little rotten dry leaf-mould may be added if come-at-able, or even a little sandy peat, or a little broken charcoal; but rotten dung should never be used at such time as a component of a compost. If extra vigour in particular cases is required it can always be given by surface-dressings, or manure-waterings. Many render their plants sickly by placing crude matter about their roots, which, when water is applied, gets into a sour soapy mass. They treat, in the short days of autumn and winter, a pot plant in a window, just as they would treat a cauliflower plant in summer. The growing and the flowering principle are just at the antipodes of each other. *Robust, rather than luxuriant, vigour—the greatest quantity of bloom in the smallest possible space—ought to be the aim of the gardener.* Need I say that the pots should be drained so that the water passes easily through them.

5thly. *Water carefully.*—Easier said than done. Water thoroughly when you do water, so as to reach every fibre; wait patiently till the plant is dry, and then repeat the operation, is the whole principle involved. And yet, how few understand it; or, if comprehending it, practice it. I believe that nine-tenths of the deaths of plants in pots are owing to the water can. The reasons of this have been fully explained. The dribbling system, in course of time, leaves the mass of roots as dry as an unused whistle, while at the surface there is a continual struggle between roots being scorched up at one time, and making fresh efforts for existence at another. To the question so very often put, "How often shall I water my plants?" no more definite answer can be given than, "Just when they need it: let them drink only when they are thirsty." Heat and light, the perspiring processes going on, the state of the plant—whether growing or resting, whether in bloom or maturing its growth, whether succulent-stemmed or hardwooded—must all be taken into consideration, and then it will be seen not only that there is a little philosophy in the growing of a plant, but that the plant that may require a refresher twice a-day in July, may be amply supplied with twice a-week in October, and twice a-month in December. As a general rule, unless when flowering or showing bloom, succulents will require little water from this time until April. On the same principle, Scarlet Geraniums will suffer less from dryness than florists' Pelargoniums; and these, again, will not suffer so much as the harder-stemmed fancy varieties. From this time until May the water used should be soft, well-aired, and not lower in temperature than from 55° to 60°, unless in particular cases, such as when a plant has become very dry; little or no water should be allowed to stand in the saucer, never to rise higher than half the height of the drainage during the dark months.

6thly. *Strive to keep the plants in small pots.* You will not only thus save room, command the greatest amount of bloom in the space, but have the means of arranging your plants in fresh combinations, in vases, boxes, or

baskets, in moss, &c., at pleasure; and thus the watering be reduced to a minimum of labour and care.

7thly. *Never hesitate to sacrifice a small present pleasure to realise a high future enjoyment.* Here is a Fuchsia, beautiful in summer, has still a few flowers at the points of its shoots, and for the sake of a flower then and now, you are to keep it in during the winter, though its thin and sickly foliage already gives one the blues. If turned out in the sun a month ago, housed any where from frost in winter, pruned, and fresh shifted in spring, you would have had something to look at next season. Here is a Pelargonium, lanky and bandy-legged, having a few stray flowers since August. What can you do with it now? If you cut it down, it will be mid-winter before it breaks, and how wretched-looking before. The cuttings will be useless, or involving more trouble than they are worth. If that plant had been cut in, pruned in July or August, the cuttings would have been nice little plants now if you wanted them. The old plant would have broken afresh; you could then, by removing the old soil, have shifted into a similar or a smaller sized pot, have had a pretty bush to survey all the winter, and the hopes of a fine sight in spring and summer.

8thly. *Never, if possible, give a check to roots and branches at the same time.* Our last example of the Geranium will shew this. We prune back the unutilized roots and stem, cause fresh roots to be produced, and when these are several inches in length, we slightly prune and disentangle the roots; and the young shoots, by a reciprocal action, cause fresh roots to be formed. Now we might prune the top, and fresh pot at the same time, and yet succeed; but we should lose time by the process, and in delicate cases lose the plant too. See, some time ago, some most valuable suggestions on transplanting, by Mr. Beaton.

9thly, and lastly for the present. *Attend to cleanliness.* Look on the leaves of plants as performing functions analogous to that of your own lungs; and a covering from dust will be secured for them at one time, and a sponging with tepid water no stranger at another. And the best of it all is, that the more trouble you bestow on your pets, the better you will like them. R. FISH.

JOTTINGS BY THE WAY.

(Continued from vol. viii., page 415.)

OSMASTON MANOR, THREE MILES FROM ASHBOURNE, DERBYSHIRE, THE RESIDENCE OF F. WRIGHT, ESQ. Mr. Lamb is gardener there.—This is quite a new place. We have already noticed it when writing on Coniferæ, showing how they have planted a considerable number of *Cedrus Libani*. We have now to add a few notes on the new gardens. The vineries are built on the same plan as those mentioned by Mr. Fish, at Kingston, in a late number—that is, a rather flat ridge-and-furrow-roof. The vines are progressing favourably. In the centre, across the house, is a strong shelf; on this shelf Mr. Lamb had placed vines in pots, which produced some fine fruit, of a good colour, and excellent flavour. The vinery, for there is one finished, is made use of as a plant-house as well, and had in it some well-grown specimens of stove plants, particularly *Alamanda cathartica*, *Echitis splendens*, *Stephanotis floribunda*, *Schubertia graveolens*, *Raphistemma pulchellum*, and several species of *Æschynanthus*, all in flower. There is also a range of plant-houses, one half of which only is complete. In a stove house we noticed a very fine spike, with several branches, of that difficult orchid to bloom, the *Renanthera coccinea*. The plant was healthy, and of a dark green. The method of causing it to bloom was first to grow it freely, and then give it a severe rest. *Oncidium papilio*, the best variety, had seven

blooms expanded, and was a large, healthy plant. The collection of orchids, however, is but small as yet; but it is intended to increase them much as soon as the entire range of plant-houses is finished. In the greenhouse the *Mandevilla suaveolens* was finely in bloom, also a good specimen of *Solanum jasminoides*, and *Kennedyia Maryattii*. There was also several standards of that fine old plant, the *Olianthus puniceus*, which is a novel but very striking mode of growing this plant, worthy of imitation. In an old greenhouse near the mansion there was a fine standard, in full bloom, of *Bignonia grandiflora*, with its large, trumpet-shaped flowers. The stem was more than six feet high, and the branches drooped round it in the umbrella form. It was a striking and ornamental object. In the centre of the garden is a very remarkable object—a lofty stone tower, with a winding staircase, which leads to the top. From this elevation splendid views of the surrounding country are seen. The use of this lofty tower is to convey away all the smoke, not only from every fire in the garden, but also from the dwelling-house, or mansion; so that there are no chimneys to be seen on the premises; yet, though cooking was going on in the kitchen, very little smoke appeared to issue from the tower. We had the privilege of seeing through the house, and were much pleased therewith. Everything is on the largest scale to save labour. Ascending and descending platforms convey coals, and every other needful thing, to the level of each tier of rooms. Water, too, is conveyed by machinery, and every possible convenience is managed on the most approved modern practice that science and skill can bring into play. Indeed, the description of this place, from the number of interesting and useful objects in it, would fill a rather formidable volume, especially when everything now in contemplation is finished.

To return to the garden. The garden walls are hollow, and near the ground have hot-water pipe inside the hollow to heat them. These answer well. Though the peach-trees have only been planted three or four years, they were bearing some excellent fruit, and were very healthy and vigorous. The walls are covered at the top with a projecting iron coping, with contrivances for hanging protecting material; canvass, for instance, from them down to the ground. An excellent plan. The trees are trained to iron-wire-rails, stretched out against them, and about eight inches apart. There did not seem any difficulty about training them, and they are certainly neater than the old method of nails and shreds.

The next place we visited was *Rolleston Park*, the seat of Sir Oswald Mosely, Bart. Mr. Atkinson is the gardener. This place we have often referred to, on account of a remarkably fine *Abies Douglassii*, and *Pinus Sabiniana*. Both these fine specimens continue healthy, and are progressing quickly. The *Abies* is now nearly forty feet high, and twenty feet through, very densely clothed with branches. The *Pinus* is quite as high, but is not so dense; the stem is full three feet round. There is also a good specimen of *Abies Menziesii*, fifteen feet high, and many others very interesting, which our space forbids us to dilate upon. We must, however, mention, that on the walls in the kitchen-garden was a large crop of excellent peaches and nectarines, and a great crop of melons in the pits.

On the front of the vineries is a large square of ground planted as a botanic garden, according to the natural system of Jussieu and Decandolle. Sir Oswald Mosely is passionately devoted to his garden, and is a fine old English gentleman, even of the present day. The place is well worthy of a visit. The gardener, Mr. Atkinson, has been there about twenty years, and is a man of science and unassuming manners. He has a very respectable collection of stuffed birds, all cured and set up by himself during his leisure hours. It would be

most beneficial if every gardener was encouraged to do so likewise.

T. APPLEBY.

(To be continued.)

THE TALL LOBELIAS.

THAT these are florists' flowers, in the sense that term is used, there can be no doubt. Mr. Glenny's rules, by which we may distinguish this class of plants, are—1st, The power to be perpetuated and increased by slips, and other modes, independent of its seed; 2ndly, The power to produce new varieties from seed, capable, like their parent, of being perpetuated; and 3rdly, it must possess sufficient interest and variety to be grown in collections. That these rules are just and correct, we need only glance at such plants as *Calceolarias*, *Cinerarias*, *Carnations*, *Dahlia*s, and the like.

Though the Tall Lobelias have never, that we know of, been shown in collections, or had prizes offered for them, yet there is no reason why they should not. In respect to brightness, and variety of colours, they are surpassed by few, especially in that always-admired and far-off-to-be-seen colour, scarlet or crimson. That they may be greatly improved is certain, from the progress already made; witness the variety named *Queen Victoria*, compared either with the original species when introduced from Mexico, and named *Lobelia fulgens*, or with the old *L. cardinalis*. With regard to diversity of colours, we have already a goodly assortment, ranging from pure white to pale blue, dark blue, purple, scarlet, and crimson. There is variety enough even at present; and if our indefatigable friend in such matters, Mr. Beaton, would try his practised hand at them, we have not the shadow of a doubt but he would, in a few generations, produce all the colours of the rainbow. When I have got over the hurry-scurry of establishing myself in my new occupation, I shall try my unskilful hand at them, and trust many of our florist friends, with their usual perseverance, will also work in the same field, and I am sure then we shall have a very superior race of tall Lobelias.

To forward so desirable an end, I shall write a few brief papers on this fine race of really showy plants, whether cultivated in pots to be exhibited in collections, or as ornaments for the flower-gardens, grown in masses in, as it is called, the bedding-out system; and for this latter purpose Mr. Beaton will wish every success.

There is no doubt that the hardy species from North America will hybridise with the more tender ones from Mexico; and thus we shall attain, in a great degree, another desirable object—the acquisition of a more hardy race. Botanists rejoice when their specific distinctions can be preserved intact, and in the case of orchidaceous plants they are quite safe; but there is scarcely any other tribe of plants with which the hybridiser does not make sad havoc (as they think) with pre-conceived notions; so that at this day there are thousands of so-called species that may be changed, and, as far as beauty of colour, form, and substance are concerned, be improved, by cultivation and cross-breeding. This improvement has been, and will continue to be, a source of never-failing, innocent, healthful, and amusing occupation to hundreds of human beings. Premising thus far, we shall return to our object—the cultivation and improvement of the Lobelia.

As there is nothing like order in every proceeding, I propose to arrange our subjects under the following heads:—1st, Propagation, by seed, by cuttings, and by division; 2nd, Soil; 3rd, Cultivation in pots for exhibition; 4th, Hybridising; 5th, Preserving through the winter.

Propagation by Seed.—As these Lobelias flower late in the year (that is in August), by the time the seed

is ripe it will be too late to sow it, unless the raiser has the convenience of a greenhouse. I will, in the first place, suppose he has not, then the seed must be gathered, cleansed from the seed vessels, and carefully preserved in paper in a dry, cool room, till March; then prepare some light soil composed of sandy loam, vegetable mould, and sandy peat, in equal parts. Mix these well together with the hand, and let the soil become partially dry; then shift a portion of it, for the surface, through a fine sieve; reserving the parts that will not go through the sieve. Procure some wide, shallow pans, with a hole in the bottom to let out the superfluous water; place over the hole a large piece of broken potsherd, or an oyster shell; then cover the bottom of the pan with a layer of smaller potsherds, and upon them put an inch or two of the rough siftings of the compost; press this down level and firm, and then place upon that a layer of the compost unsifted; let this layer very nearly fill the pan. Upon that, finally, put a thin layer of the sifted compost, level it down, and press it gently with a smaller pan, or a round, flat piece of wood made on purpose. Then water gently, but sufficient to wet the whole thoroughly through. Let it stand an hour, to allow the water to settle through, and the surface to become partially dry. It is then ready to receive the seed. As this is almost the smallest of all seeds, it must be, as it were, dusted over the surface, and some very fine powdery compost dusted as thin as possible upon it. Press this very lightly upon the seed, but give no water—the moisture in the soil below will ascend and moisten the seed and its light covering sufficiently for the time. Place the pans in a cold frame, or, what is better, upon a very gentle hotbed, under glass. If the cultivator has a greenhouse, the seed may be sown as soon as it is ripe, in the same manner, and be placed upon a shelf near the glass. In either case, as soon as plants come up, and can be handled, prick out the seedlings thinly in other pans prepared similarly to the seed-pans. There will be this advantage in the autumn-sowing, that the plants will be forward enough to plant out in nursery beds earlier in the following season than the spring-sown ones. It is very likely some will flower that season, and the best only should of course be kept, the rest will do to plant out in the borders of the flower-garden, or be thrown away at once. Such as do not flower should be taken up in the autumn, potted in small pots, singly, and placed either in a greenhouse near the glass, or upon a bed of coal ashes in a cold frame, well protected from frost till spring, when they should be planted out again to prove them.

T. APPLEBY.

(To be continued.)

CONIFERÆ.

(Continued from page 10.)

CUPRESSUS LUSITANICA (Cedar of Goa, or Portuguese Cypress).—A very elegant drooping tree, fifty feet high, grown extensively in Spain and Portugal, hence its specific name. It is not hardy enough to bear the severe cold in the northern parts of Britain, but would, very likely, be able to live in Devonshire and Cornwall near the sea.

CUPRESSUS MACROCARPA, *syn.* **LAMBERTIANA** (Large-fruited Cypress).—This is a noble tree, growing upwards of seventy feet high, with a stem nine feet in circumference. The leaves are rather broad compared with the rest of the species in this genus. They are of a bright green on the upper surface, and of a silvery, glaucous hue on the under. This peculiarity renders it a fine tree to ornament the landscape in this country, as well as a desirable species to introduce largely into the pinetum. The timber is hard and close-grained, which

quality, when the plants are cheaper, will make it valuable as a forest tree, especially as it has proved to be perfectly hardy. Mr. Hartweg found it in California, and says it forms one of the noblest trees in that country, and when fully grown bears a strong likeness to the majestic Cedar of Lebanon. We strongly recommend this beautiful species to the lovers of Coniferæ. The price is moderate; good plants, two feet high, may be had for 2s 6d each. There is a variety named *fastigiata*, a closer-growing and more upright tree, equally hardy, but more rare.

CUPRESSUS MAJESTICA (Majestic Cypress).—A tree well-named, if we may judge from the growing appearance of the young trees we have in this country. Very little is known about it; even its native country and origin are unknown. It is very rare.

CUPRESSUS THURIFERA (Frankincense-bearing Cypress).—A perfectly hardy, fast-growing tree, native of Mexico; in that country it often reaches one hundred feet high. The habit is different to the generality of Cupresses, being thin of branches, and small-leaved, yet it forms a fine tree. We have seen specimens of it about fifteen feet high, quite upright, and very handsome. Though a native of Mexico, it bears our climate well, growing in any soil not actually wet.

CUPRESSUS THYOIDES (White Cedar, or Thuja-like Cypress). This common tree has been separated from the Cupresses by Spach, a writer in a French work on botany, as, we think, quite unnecessarily, and, therefore, we have retained it under the genus where Linnæus placed it. It is, as is well known, a beautiful tree, growing upright, and thickly clothed with branches and foliage, so much so, that no object can be seen through it. This renders it useful to hide any unpleasant, low building, or other unsightly object. It delights in moist soil in America, its native country, but will thrive with us in deep loamy or sandy soil. The wood is fine in grain, soft, and light, and easy to work, and will bear without warping great extremes of drought and wet, hence it is highly valued in the western hemisphere. In this country it seldom reaches more than thirty feet; but in the swamps of America its altitude is often from seventy to eighty feet. In the grounds at Elvaston Castle, in Derbyshire, the variety named *O thyoides variegata* is planted in a close row to form a hedge, and a beautiful object it is. This variety, intermixed among other low-growing green Coniferæ, makes a pleasing variety. There are several more varieties named—*glauca*, *nana*, *Kewensis*, and *atrovirens*—which, in large collections, are desirable enough to cultivate as objects of curiosity.

CUPRESSUS TOROLOSA (Twisted Cypress).—This is an eastern species, growing in Nepal, on the Bhoton Alps. Mr. W. Appleby, the son of the writer of this article, Curator of the Punjaub Horticultural Garden there, describes this tree as being one of the finest objects in that country. The garden is situated about sixty miles from the Himalayan Mountains, the native habitat of the elegant *Cedrus deodara*. Like that handsome tree, the *C. torolosa* is hardy enough to brave our winters, at least, in the south, and is a truly beautiful and ornamental tree. Every collection ought to possess several specimens of it. It has been raised plentifully from foreign seed, and is cheaper than the *Deodar*. Plants well-rooted, three feet high, may be had from 2s 6d, so that no one need be without it. As a single plant on a lawn, it rivals any other species of Coniferæ in beauty. It loves a dry soil, and thrives in a high situation, if protected slightly whilst young. The timber is excellent, being close-grained, and capable of a high polish, rivalling in value the wood of the *Deodar*. As the plants are so reasonable in price, and the timber so valuable, it is worthy of the attention of planters on a large scale, especially on the high waste lands of Ire-

land and the southern counties of England. If our large landed proprietors were to plant largely this species, *Cedrus deodara*, and other new and valuable cone-bearing trees, nurserymen would import seeds more largely, and sell them still cheaper, to meet the demand. Our grand-children would then see quite a new feature in the landscape of the country, as well as be in possession of greater variety of valuable and useful timber.

CUPRESSUS UHDEANA (Mr. Uhde's Cypress).—A native of Mexico, where it grows to sixty feet high. Very unlike the rest of the genus in appearance, growing very fast, but not quite hardy enough to bear the open air. It is, however, a desirable, handsome plant for a conservatory or a crystal palace, like the one now erecting at Sydenham.

T. APPELBY.

(To be continued.)

NOTES ON THE CABBAGE TRIBE.

It would, no doubt, be somewhat interesting, were we able to trace the history of many of our most useful fruits and vegetables, from the period when they first afforded our fore elders that scanty meal which the backwood Indians are at the present day obtaining from natural productions, and which may hereafter assume a widely different appearance, when subjected to the skilful-directed cultivation of centuries yet to come. But whether the wild fruits of the unexplored forest, or that "herbage on which so many of the human race have been accustomed to look for sustenance, be ever destined to become the parents of families that may compete in usefulness with our corn, rice, fruits, and vegetables," as already known to us, is a problem to which the boldest of us cannot venture on a solution. Be that as it may, there is no doubt but many natural products might be so far improved by cultivation, as to increase their usefulness to the wretched inhabitants of those countries where civilization has not yet introduced anything better; but whether the restless enterprise of the "white man," will direct itself to the improvement of those native products, or be content with driving them before him (as he has been accustomed to do the "natives" themselves), and supply their places with things he has been taught to look upon as forming all that is useful in life, is more than any one can now venture an opinion upon, as it is a notorious fact, that notwithstanding the spread of civilization, and the increased comforts, which, as a nation, have been gradually pouring in upon us during the last three centuries, the number of plants from which these necessities or luxuries have been obtained has received very little addition the whole of that time. If vegetables be more plentiful in England in the nineteenth century than in the sixteenth, it is only, or nearly so, that the same kinds are more extensively cultivated now than formerly. Discovery has added but little to our stock, and cultivation has been more directed to the improvement of what we have, than in searching for new objects of a useful kind to work upon. Now, though I do not disagree with those who so laudably endeavour to carry on improvement to the highest possible standard, yet I think we ought not entirely to forget new objects, and those who struggle, however ineffectually, to render them serviceable to our use, are entitled to our warmest thanks; as, notwithstanding the tardy progress they may make, if the object they have in view be a deserving one, success will sooner or later crown their efforts. It may be true, that certain lawgivers will pretend to hem in the field of improvement, by pointing out how far it is possible to go, but even their lines of demarkation are so remote, so ideal, and so often over-

come, that no real benefit can be had by attending to them. Amongst other "fixed laws," it is "laid down," that cultivation weakens the constitution of a plant:—renders it less able to endure the rigours of winter, and prevents its living to so great an age. To the former of these restrictions, might we ask, how does it happen that those valuable stone-fruits of ours ripen so well, and stand our winters, when they are natives of a warmer and more sunny clime? The limited period at which a variety will continue to be profitable, is, however, certainly a proof that cultivation has here extended its favours at the sacrifice of the producer's existence; but this is more than compensated by their increased usefulness, so that it has been laid down as a rarely deviating law, that whatever tends to an early development, has a like influence in hastening to an ultimate end. Fruit-trees that become fruitful at an early age are rarely long lived, and the same with other things. Now, this law, as well as its various ramifications, has been taken advantage of by those who have studied our garden politics, so that they have been able, every now and then, to "report progress," in the shape of a production differing in some respects from the materials they had obtained it from. That this is daily accomplished, is manifested from the many varieties of fruits and vegetables we now have offered to our use, though it cannot be said that all are improvements, neither are they always different from those which preceded them; but that mighty judge, the public, soon discards what is spurious or indifferent, so that only the best is at all patronised, after a trial has been made.

In taking this cursory view of what cultivation has done, and is doing, in the way of changing the constitution or habits of some of our most useful vegetables, I have done it for the purpose of calling attention to one of the most important in the class—the *Cauliflower*. This delicate member of the large Cabbagewort family would seem to have had a common origin with the cabbage, and other species, but by a series of patient "breeding-in-and-in," the old characters would seem to have been overcome, and while the Cabbage, as one branch of the family, has been coaxed to conform to our wishes, by presenting us with a mass of its foliage folded in beautiful order into a globular or conical-shaped parcel, the Cauliflower has been directed to take another turn, and taught to form its embryo flower-buds into that close compact form, which we term "a good head." Other variations of the uses of this all-important family might be adduced, but the above is sufficient to prove the wide range which cultivation is capable of taking, and the consequent results. Now, though they may possibly both claim a common parentage, yet there is a considerable difference in their hardihood—the cabbage standing unscathed where its kinsman would have perished. That this difference is brought about by the cultivation of the latter being directed to the most delicate part of the plant, is certainly the cause of this want of hardihood; but be that as it may, the difference in the two, amounts to something like three or four degrees of latitude, or more; other conditions being the same. By this it will be seen that Cauliflowers ought to exist or stand the winter in the south of England without any more protection than is necessary for cabbage plants in the north of the kingdom; and though there is often a little more difference still, yet the principle is correct. But the two productions are essential at the same place, consequently, the more tender one must be protected through the inclemency of our winters, while the more robust, being left to brave the storm, may, nevertheless, endure its rigours with less injury than its sheltered kinsman. Cauliflowers are, however, ticklish things to deal with, and some other conditions must be complied with, to ensure a successful result; but the subject is one so fraught with

importance, that I find the subject of wintering them must be postponed for another week; in the mean time, let our less experienced friends take care not to nurse these plants into that tender state which makes them as susceptible of cold as if they had been denizens of the greenhouse. A sturdy, healthy growth can only be ensured by continued exposure, and let them be only covered up when the weather threatens to become very severe. But more of this anon. J. ROBSON.

THE WIDOW INDEED!

By the Authoress of "My Flowers," &c.

It is remarkable to observe how unwilling people are to trust in God. If *our own* hearts did not teach us this, we should be quite ready to say the whole world is beside itself, for having such large and full promises given to it, and yet refusing to receive them. And so it is; it is mad, and guilty too; but we are all in the same condemnation. There is scarcely one among us who would dare to rest upon one of God's promises if it went against the promise of the world.

I know, however, one old woman who has dared to do so. She has acted upon, as well as talked about, trust in God; and though she "was young, and now is old," she has not found the "promise" fail.

Old Betty is a widow of above fourscore years: she is, in fact, eighty-nine. She was quite a young woman when her husband died, and left her with two daughters and a son; but he left her with the "promise," also, and he could not have done better for her. A man who had had an affection for Betty in her youth came forward, in due time, and wished to make her his wife. She had no objection to him in himself, but she loved the "promise" better; and chose to abide "under the shadow of the Almighty," who had seen fit to take her earthly prop away. Two or three times Betty was urged by this old admirer to change her mind and marry him, but nothing could move her. She said she was not "afraid but the Lord would provide her a bit of bread," and take care of her children too—and a widow resolutely she remained.

Her eldest daughter married, and died young. The younger became a cripple, from rheumatic gout, and lay for years and years cramped and agonized on a little bed in the corner of the kitchen, with her hands and feet twisted almost into balls, and suffering the most acute pain. She died soon after we first knew the little household, but I can still hear the bitter cry of "Moth-the-r, moth-the-r," which the poor sufferer constantly uttered, as she lay in unspeakable torture. Poor Betty waited upon her by night and by day; she was a tender mother, and did all she could to soften the trial of this poor afflicted creature, but nothing could ease the pains, until the Lord stretched forth His hand and took her.

Betty's son was a "waif and stray." He was wild and worthless in every one's opinion but hers. He was transported after the Riots of 1830; and, excepting two letters that came soon after his going away, she has heard nothing of him. Whether he died, or forgot her, she cannot tell. His term of transportation has long since ended, but he neither comes or writes; and Betty weeps bitter tears over his loss, and her own uncertainty.

The "promise" has never failed poor old Betty through all her trials. When Naomi was left desolate, a daughter-in-law clave to her, and cherished her; in Betty's bereavement a son-in-law became to her as her own, and clave to her with the fond affection of a daughter. He never left Betty's roof from the hour his wife died. He never dreamed of marrying again; he had no child, and Betty was thenceforward his only care. When all her children were swept away, George stood in the gap; he laboured for her, he comforted her; he was a man of few words, but of many deeds, and he cheered and supported her desolate widowhood.

Betty was enabled to turn a penny honestly, by selling a little gingerbread, and a few apples and potatoes in their season. There is always something to be seen still in her window of that kind, although, in these days, she finds

pennies are few among her humble customers. A daily walking carrier from the town has for many years spent his mid-day hours in her cottage, for which he pays a trifle, so that Betty has added her mite to her son-in-law's labours to pay their rent and live. Cleaner or more honest creatures than the widow and her devoted son-in-law the parish never produced. George worked for years on a neighbouring nobleman's estate, and not a word was ever spoken against him. Those who knew him could trust *him*, where none else could be trusted; and he was so civil, so harmless, and so humble, that every one liked and respected him.

But, alas! this comfort has been disturbed in the good and wise providence of God. The aged widow now dwells alone in her little cottage. Her second prop has been taken away, and she rests singly on Him who says "Let thy widows trust in me."

It was a bitter parting. Poor George had been a great sufferer at times for many years, but his last illness was very severe, although he seemed better, and Betty had no idea of his end approaching. He called her up one night in a great hurry, but had nothing to say when she went to him. He was odd in his manner, but still she was not alarmed, and when he wished for a cup of tea, she went down stairs to make a fire, little supposing that on her return she should find him dead. But it was so. The kind eyes were closed, the active arms were still, the voice that was always welcome to her was silent, and poor Betty found herself again a childless widow.

The poor old woman still clings to the "promise," and as she relates the short and simple story of her life, she blesses God for his goodness in never having left her to want. Her mouth has been filled, although with homely fare, bread has been the chief part of her diet, with the weakest liquid that could be called tea, and what causes her heart greatly to rejoice is, that she has never been in debt. She pays to the uttermost farthing every thing she owes, and while a shilling remains owing at the shop she is restless and uneasy.

Her prospects on earth are now somewhat dark. Her rent is high; the carrier's health failing, which would cut off one little means of help, and the failure of potatoes in her little bit of allotment ground, depriving her of that principal support. But her friends, who love and respect her, take no rent for her ground, and she cheerfully says "The Lord will keep me;" and has no excessive dread of the Union, should it please God to bring her to that end. But as yet she holds quietly on her way. She does all her little household work; washes her own clothes; rises at five as usual; and "muddles about" as she says, all day long. It is affecting to see her sometimes looking over all poor George's working tools, which she hopes to sell—a little story belongs to almost all of them; and she seems to see him again seated by the fireside as she spreads them out before her. She is now unable to reach the church, but a lady goes every Sunday morning to read a portion of Scripture, and a simple sermon to her in her little dwelling; and she loves to listen to the Word of Life more and more, now that all other things are passing away. She has a good hope through grace—she has tasted the Word, and found Him "faithful that promised;"—"bread" has been given to her—"water" has been "sure" to her—she has wanted "no good thing." Young and old have died around her—the changes and chances of this mortal life have happened to rich and poor, but old Betty stands like an aged oak, with a twig or two still green, just where she stood more than forty years ago; her head is strongly bent, but her eye is bright, her actions vigorous, and her affections warm and strong. She is now asking anxiously after a young midshipman, who is on his homeward voyage, who has grown up before her eyes, eaten her gingerbread, and waved his sea-cap twice to his old friend, as she stood weeping at her door to see him depart to his ship. *Her* son is lost to her, but she loves the sons of others; and there are some whose first visit, on returning home, is paid to poor old Betty.

There is no fear for those who are "widows indeed," who trust in God, and continue in supplications and prayers night and day. They have a treasure-house, and a key that unlocks it; they have a God, and a way of access to him; they have a promise, and a faithful Promiser. No man can meddle with their promise "or their peace. The Word of the Lord hath said "Let thy widows trust in me." "Heaven

and earth shall pass away," but God's "Word shall not pass away." Let the example of poor old Betty encourage all widows to *trust in God*.

COTTAGE GARDEN, AND WHAT SHOULD BE THE NOVEMBER CROP.

BREADTH, 27½ YARDS; LENGTH, 44 YARDS.

East hedge.

Alley and Raspberry border, 6 feet.

Cabbage tribe succeeded by next spring and summer's mixed crops.

	feet.
Two rows of prickly spinach	4
Alley	1
Three rows of spring brocoli (Knight's Protecting)	9
Alley	1
Three rows [Apple tree] of early spring cabbage	6
Alley	1
Four rows of Scotch kale	12
Alley	1
Two rows of savoys	4
Alley	1

.....
Potato division (autumn-planted).

Sixteen rows of potatoes, at 30 inches apart

Apple tree.

.....
Succession winter division following the mixed crops, and to become occupied with the roots next season.

A flying crop of lettuce succeeded the two rows of spring cabbage, and the row of ash-leaved kidneys, now in their turn succeeded by a trench of parsnips	3
A ridge of turnips (swedes)	4
Alley	1
Two rows of transplanted swedes, or sown turnips	3
Alley	1
One row of [Apple tree] savoys (strong and early planted)	2
Alley	1
Two rows of autumn cabbage	2
Alley	1
Two celery trenches (growing between them a row of cabbage, savoy, or stone turnips)	14
Two rows of strawberries (growing between them white and black Spanish radishes)	7
Alley (or a row of potato onions)	1

Walk, 4 feet.

North hedge.

Walk, 4 feet.

Gooseberry and Currant border, 3 feet.

Nut tree in hedge.

communicate the result of the harvest in Northumberland. The season, though I must call it critical, has been an average good one. The months of July in the gardens, and August on the moors, were very productive, but then many hives had received so severe a check from the miserably cold and rainy weather in June, that they were not in a condition to profit by the succeeding fine weather.

It may not be unacceptable to describe the plan I have pursued, in a locality where the honey season is short, and which has answered so well, that I always intend to adopt it. My hives are Mr. Golding's "Grecian," which I am pleased to see are pronounced by "A Country Curate," the "*ne plus ultra*" of hives. Preferring, as a matter of taste, "the time-honoured straw hive," to those of other materials, it seems to me that the extreme lightness and simplicity of these, with the facility of working them, and having the whole contents of the hive at the disposal of the operator, entitles them to that distinction, while the price places them within the reach of at least a rich cottager. Following the directions in the shilling Bee-book, when the hived swarmed I cut out all the royal cells, and returned the swarm, with its queen. No re-issue took place, and the whole strength of the hive being thus concentrated under a queen two years old, the bees stored 28 lbs. of honey in a super during July. I should add, that I have always found ventilation, and affording additional room, quite ineffectual in preventing swarming.

I am almost inclined to dissent from the sentiment of "A Country Curate," "that there is nothing new under the sun," for the destruction of drones immediately after swarming is a feature in the economy of the bees which I do not remember to have been noted by any author, and its singularity must plead an excuse for a recurrence to a subject which may seem tedious. The early destruction of drones and drone pupa, alluded to in Nutt's book (an appeal to it as an authority would surely be a retrograde step in the path of apiarian science), is what all bee-keepers have experienced in an ungenial season *before* swarming. This year it was seen in many hives, in June, but have we any record not to render its occurrence immediately *after* swarming unparalleled? It would almost tempt me to depopulate a hive, in order to watch the effect on its future prospects. May I say, the idea of a reserve for younger queens is fanciful, those left by the old queen being hatched within at most ten or twelve days of each other, and to the last the succession to the sovereignty is doubtful, as I this year ascertained, for in a hive which did not swarm a second time, the first hatched queen, having disposed of two others, was herself destroyed, when a week old, by one (the last) which had not been liberated from her cell more than twenty hours. Does it ever happen that a stock which has swarmed will swarm again with the young queen, of course after an interval of some weeks? But even supposing such an extreme case, the queen would lay drone eggs before making a deposit in the royal cells.

These observations occupy much valuable space in the pages of THE COTTAGE GARDENER, which, however, are lent to the extension and progress of science, as well as practice, and as the latter must always be dependent on the former, it is hoped they may not be considered inappropriate.—INVESTIGATOR.

SITTING HEN'S NESTS.

A WARM situation has advantages which may not always be foreseen, and the following instance is remarkable, showing how long eggs may be left uncovered without destroying their vitality. I had supplied the eggs (13), and lent a sitting hen to a neighbour, and when she had sat in a granary ten days, was shut out, through the carelessness of a servant. Being a stranger in the farm-yard, the hen was not recognised, but supposed to have strayed in from an adjoining walk, and thirty hours elapsed before it was discovered that the hen had left her nest. The farmer's wife despaired of her brood, but, to her surprise and pleasure, eight chickens were hatched. The tiled roof of the granary was fully exposed to the rays of the sun, and the temperature very high, probably above 80° during the day, and not much lower at night.—INVESTIGATOR, *Lilburn Tower*.

HONEY SEASON IN NORTHUMBERLAND.

THE honey season being over, and the last hives brought from the moors, in accordance with the wishes of some of the correspondents of THE COTTAGE GARDENER, I will

CONFINING BEES.

It is a very singular coincidence, that the hive from which a number of drones were brought out dead, became queenless, as well as Nos. 2 and 13, of "B. B." Its history confirms the opinion of "A Country Curate," that the death of the drones was not the cause of the subsequent misfortune. The drones were brought out June 16th, and the hive swarmed on the 19th, and it is very certain that the old queen would not have left the hive unless the royal larvae had been in a satisfactory state of progress.

Piping was listened for at the usual period, but in vain. Neither was a young queen seen, and as the hive appeared weak and dispirited on the 9th July, the combs were taken up on the bars and examined. Neither queen nor brood being found, a young queen was introduced, and then the hive revived, and on the 5th of August it contained a large quantity of brood, being then sent to the moors; it is now (Sept. 11th) working vigorously in a super. This condition of these hives is not likely to have been caused by the wet and windy weather, as young queens do not leave their hive unless the weather is fine; however, it is not uncommon for a swarming stock to become queenless, and this is not surprising, when we consider the risks to which queens are exposed during their frequent excursions. Some instances of this have fallen under my observation, and perhaps some of the readers of THE COTTAGE GARDENER may be able, from their experience, to give some information on the subject, and also as to what is the immediate effect of a young queen's absence and loss; if it resembles the wild disorder (which all bee-keepers must have witnessed) which takes place when a queen dies in the hive, or is removed after she has begun to lay eggs. This is a subject of importance, to which I have given some attention, and to which I may revert, and should also be glad to learn any observations that have been made on the longevity of queens, whether they have been traced more than four years, and at what season their death usually occurs.

The enquiry of "C. R. R.," July 1st., has just met my eye, and I am happy to be able to answer it. In a hive to which I had returned the first swarm, by taking away the old queen, piping commenced on the 8th day, and, as is usual, with the long note, for the earliest nymph being liberated as soon as she arrives at maturity, is unable to fly for some hours, and the expectant swarm is compelled to wait. There is always piping as long as there is a plurality of nymphs and queens.

May I suggest that the earthenware-pan described July 15th, will not prove a suitable habitation for bees in winter? The non-absorbing quality of the surface will cause great condensation of moisture, and the combs will in consequence become mouldy, and the bees probably unhealthy. Could not these bees now be joined to No. 2, which is no doubt queenless. They might be removed by driving. If a hive of the circumference of the pan is not at hand, a bell-glass or other vessel might answer, by pasting paper over the inside, the bees would probably not refuse to ascend, and then the required weight of food might be supplied from their own honey, with a few pounds of sugar. Six pounds of sugar will yield 10 lbs. of syrup, and though ale may be best, water will answer to boil it in, with the addition of the rum.—INVESTIGATOR.

THE COCHIN-CHINA FOWL'S REMONSTRANCE.

SIR,—I and all our tribe have had our courage worked up to the crowing point by the boastful crow of those Spanish and Dorking cocks of yours, that they and their families are more prolific, eat less food, and are altogether more valuable than we, who have filled so many pockets with the produce of our numerous golden eggs. I am deputed by the rest to deny that we are gourmands, and to say that we eat only in proportion to our size, and that if their wives produce larger eggs, they do not produce so many, nor such rich ones. One of our family was hatched in April, 1850, laid early in August, continued to lay nine out of every ten days, till Christmas, was then broody ten days, laid again in the same ratio till April, 1851, sat three weeks, was then released of her burden, laid

in ten days, and so on. Let them produce one of their family that has done more. Then look at our little ones, how easily reared, while the Spanish tribe are notorious for moping when chickens, and for dying by the dozen. And compare us in size and beauty; some of my wives weigh 9 lbs., 9½ lbs., and 10 lbs., and even 10½ lbs., and several of my brethren weighed 13 lbs., and my father was the same weight. I am glad you will allow me to crow as well as them, and that you do not thrust pieces of wood into my nostrils, to prevent my crowing, as do some of the brutes, who call themselves men, when we are on ship-board. Enjoying this privilege, as champion for our whole tribe, I challenge "Gallus" to a fair and honourable trial of our individual merits, with an equal number of each, equal food in proportion to weight and eggs, and equality in every respect. Mind! I mean *true* Cochins, not mulattos, quadroons, &c., for allow me to say, I have travelled much, and latterly have been invited to pay many visits to professed relations, but was sadly surprised and disappointed to find that the relationship was only this—that some gentlemen from Dorking, and other places in Surrey, had married some of my wives' cousins, and these were their children. At other places I saw the descendants of families who only came from the *same place* as we did. Only think of the impudence of claiming relationship! As well might every ugly cur from the Isle of Skye claim to be a Skye terrier. Pray, Sir, do what you can to prevent this for the future, or I fear these base alliances and assumptions will quite destroy our identity. While I am about it, I'll just ask you another favour. Will you try to invent a poultry exhibition man-trap, for I was once in Sturgeon's prize pen, at Birmingham, and when half asleep, and half awake, at witching time, I think *you* call it, I was disturbed by the introduction of a sly hand into our pen, which withdrew the eggs my wives had laid, marked them, and then did the same with some other pens; these I am told were hatched, and thus my good master's breed was abstracted without pay.

In self-defence, and conscious superiority, I crow defiant,

COCK-A-DOODLE-DO-O-O-O.

SENDING COCHIN-CHINA FOWLS TO THE SHOW.

CHOOSING, catching, feeding, preparing baskets, and directing them, putting in the chickens, and tying down the lids, all is bustle, and the little cart waiting at the gate. The gardener, at present the guardian of the chickens, has just won a *second prize* for flowers. "We must stand *first* this time, Ma'am; good bye, Miss," and away rattles the little cart with its astonished burden. The dear little chickens, how modest, and how pretty they looked! How bright the yellow ones! How decided in their markings; and how bright, too, the partridge! And so they started on their way, to show their beauty among hundreds of the most beautiful in all the eastern counties. So they started. But how did they come back? Looking well and handsome, perhaps handsomer than ever, change of air seemed to have agreed with them; but—chickens no longer—they must lord it now; they must have establishments of their own; they can no longer rest contented, placed apart with pullets, and with cock birds respectively. When let out next morning, the pullets—I love the pullets, pretty confiding, tame little creatures—contented themselves with fluttering all legs and wings across the long grass, "Hock! hock! hock! there *he* is," to where the companions of their recent excursion were confined under a network of wire, and when they found joining company impracticable, returned to eat their breakfast. Not so, the yellow cock. "Young Giant" he had been called before he went, when he was in the habit of being satisfied if he could get his share of the victuals, and avoid the beak of his great red brother; but "Young Pickle" is the name he has gained for himself since he came back, for he has heard of prizes (and done his part towards gaining them, too), he has become self-willed and conceited, he will no longer remain with the cocks. He can surmount, in his eagerness, the little fence which has scarcely ever been surmounted by Cochin-China before, and nothing remains but to give my lord an esta-

blishment of his own. The great red brother, "Bully," is not clever enough to get over the fence, but remains cross, moody, and discontented, on what he evidently considers the wrong side of it. Truly, one of our west country amateurs had good reason for sending his beautiful pen of six young pullets to Birmingham last year.

The poultry exhibitions which now occur so often perform their mission well, occasioning great improvement in all good breeds of fowls; but might they not be made conducive to another?—to a more general, if less interesting, end, by improving the *general stock* of poultry in the country? Let a cottagers' show be carried on conjointly with the local shows, for the encouragement of those who, at present, only want the means to compass the choice varieties. Let a prize of a cock, a cockerel and pullet, or a sitting of eggs of some *first-rate* breed be offered to the cottager who can show a pen of six common fowls in the best health and order, giving at the same time a strong recommendation that for the future, in breeding, the good sort shall be adhered to, and kept distinct. If the show should take place in winter, the eggs might be claimable early the following spring. Some persons, from not having tried the experiment, are fearful of sitting travelled eggs, but they need not be so. Some time back, Mr. Punchard sent me a table of the result of his experience in this particular, by which I find, that out of 901 eggs sent to 63 different places, after travelling distances by sea and land varying between 14 and 395 miles, 555 chickens were hatched; about eleven-eightieths—no bad result. My own experience has proved even more favourable than his, and I have found that eggs which have travelled immense distances, have often produced a larger proportion of chickens than those hatched at home; only showing, perhaps, that when we give a guinea for a few eggs, we bestow more care and attention on them, and the hen in charge of them, than when we merely fetch them from our own hen-house. I am *sure* there are *some*, I have little doubt there are *many* amateurs, who would assist an endeavour like this, which I suggest above, by *giving* the prizes, if the poultry societies could manage the other arrangements, and it would surely conduce towards the result, for the accomplishment of which so many have written and laboured—general improvement in poultry throughout the country. In arranging the details of these and all other shows, the confidence of exhibitors especially, should be supported by the most exact precision respecting the prizes, which should be carefully noted according to precedence, and ties entered as such.

All portions of the country boast their poultry shows now. When will London have hers also? The exigence which still delays a thing so desirable in the eyes of most amateurs, is, I believe, a difficulty in finding some gentleman, with leisure, to undertake the management.

A show of Cochin-China fowls, and no mean one, we shall, however, shortly see in London; but a show without contrast or competition, for on the second of November, Mr. Sturgeon will sell by auction, in Baker-street, a large portion of his far-famed stock.

ANSTER BONN.

(Acting up to the suggestion thus made, our liberal correspondent will offer a cockerel and a sitting of eggs, as a first and second prize, to be competed for by cottagers at the approaching Exhibition of *The Winchester and Southern Counties Society for the Improvement of Poultry*.—ED. C. G.)

THE SHELDRAKE AND ITS HAUNTS.

THE first sheldrake which I ever saw, and the scene in which it made its appearance, remain firmly daguerretyped on my memory, after the lapse of many years. It was my good fortune to be spending the winter in Scotland; and those who have never seen Scotland cannot even dream what a beautiful country it is. I was staying on the banks of that noble river, the Ness, whose entrance into the sea is marked by the town of *Inverness*. The Ness is remarkable for several things: among others, for magnificent salmon. Man gets his share of these fish, but the shoals of seals which haunt the mouth of the river, appropriate the greater proportion of the finny prey. One salmon for breakfast, one for dinner, and a third for supper, is a moderate allow-

ance for each individual of this tribe of seals; because, the meal ended, and his appetite satisfied, Mr. Seal does not put his cold fish, the remains of his twenty-pound salmon, into his larder, but lets it float away for the benefit of the poorer inhabitants of the waters, and amuses himself by catching a fresh one, whenever his mouth begins to water for a little snack. Many readers will ask, *why* we allow this robbery of our salmon fisheries; and why we do not send the seals about their business? But it is of little use arguing, *who* are the rightful owners of the fish, and *for whom* the salmon ought to be preserved—for men, or for seals. A month, on the coast of Invernesshire, will teach the stranger that it is easier to *talk* of dispossessing the seals, than to *do* it.

Salmon fishing, by human creatures, begins there on the first of February. The more snowy and sleety the day, the better luck is expected. That day it *snew* beautifully, as we say in Norfolk; and I think our host caught half a dozen fine fish to his own rod, and could have captured more. I was kindly furnished with tackle, on that and many subsequent occasions. But the Ness, below the falls, is a difficult river to fish, even for adepts; and, till then, I had never thrown an artificial fly, nor seen even a live trout, much less a furious salmon, with the strength almost of a hippopotamus. To do anything in that part of the Ness, it is necessary to throw cleverly thirty yards of line, upon occasion, and to wield steadily the rod which throws it. The consequence was, that the more severely I flogged the water, the less notice would the salmon take of my flies. I sometimes fancied they put their heads out of the river on purpose to laugh at me. Then came a little temper and excitement which made matters worse. At one time, crack went the beautiful fly, of gold and silver and peacock's feathers, off the end of the line, sounding like the explosion from a French postilion's whip-lash; by-and-by, when my energies were collected for a throw which *must* get a "rise," envious shrubs in the background would detain my hook; or the rod would be smashed in two, by the violence of the misplaced effort. I would have given it up, but was good-naturedly urged to continue. Other people caught their salmon; *my* fly never entered a fish's mouth.

The valley of the Ness is lovely at all seasons. Rocks, woods, mountains, a rushing stream, arable lands, meadows, flocks and herds, huts, wreaths of turf smoke, are a few details of the panorama. Fishing soon became, with me, a mere pretence for the admiration of nature. That winter was mild, and often furnished pictures of perfect Alpine beauty: the mountain-tops were covered with snow down to a certain altitude, and then everything was green, and bright, and cheerful, and sunshiny. One day, when I had broken my rod for the dozenth time, I cannot imagine how, and was resigned to the usual good-humoured encouragement to try again next day, I mounted a commanding shoulder of a hill, and sat down to gaze around me. Soon, a beautiful bird came sweeping up the valley from the sea, in mid air, but still beneath me, and followed the course of the river, till it disappeared in the distance. It was a sheldrake, brilliant with orange, white, and some dark glancing colours, I could not tell what. I had read in Willughby, that it was "of a mean bigness, between a goose and a duck," but it looked larger than I expected, from the bright contrast of its hues, which are as conspicuous as those of a magpie, with the addition of greater variety. Tame sheldrakes must be pinioned, or they will afford very pretty sport to your gunning neighbours; and, therefore, in all the aviaries and ornamental waters that I have since visited, no bird of the kind has ever delighted me with a performance resembling that gaudy sweeping flight up the glorious valley of the Ness. I afterwards found that the birds are not uncommon in that neighbourhood, and that they are little sought after by sportsmen. They are good-for-nothing to eat, and their feathers are not usually employed for artificial flies. More metallic tints are in greater request: the poor little kingfisher, not found so far north, yields its skin in England, to be imported into "the land o' cakes." Sheldrakes breed, too, along the coast, in the peculiar spots that suit them, as well as further south. A lighthouse keeper, who had served his turn in the extra solitude of Fern Island, told me that one of his summer amusements was to lay hands on the little sheldrakes hatched there, and to rear them for sale to the dealers in tame waterfowl.

The sheldrake is hardly patronised, as it ought to be, for the decoration of the pond in the pleasure-ground. Orange or bright bay, black or metallic bottle green, and very pure white in the plumage; with bright red bill, and feet, and legs, as Willughby says, "of a pale red or flesh-colour, the skin being so pellucid that the tract of the veins may easily be discerned through it," are not features to be seen in every ordinary farm-yard duckpond. The slight upturning of the bill at the end, gives the same pretty, pert air, as is impressed on the human countenance by a not too snub nose. Both sexes are alike in colouring, though that of the female is less decided. This character, perhaps, also shows their intermediate place between the ducks and the geese: for in the true ducks, however gay the male, the lady is in general soberly brown or russet. I once bought half a dozen sheldrake's eggs in Norfolk (where they have bred regularly on the coast) for as many shillings. They are larger than common ducks' eggs, but otherwise similar: that is, they are of the same shape, tinted with a light sea green, and having a smooth greasy substance. A hen incubated them, and brought off two sheldrakelings, informing us thereby that the little ones are quite destitute of the gay clothing which bedecks their parents. Their down is greyey-brownish-green, like that which covers the goslings of the brown China goose; but they have four lighter yellowish spots, one on each shoulder, and one on each hip, which would help you to pick them out from amongst hundreds of ducklings. After a few days, too, it was evident from their respective increase in size, that one was a little drake, and the other a duck, beginning the world. We reared them to about a month old, when they pined and died. Why? you ought to be able to guess, if you have read Yarrell, and others, on the article Sheldrake. But let us do something better than read. Let us go and visit the breeding places of the sheldrake. We shall then see why Willughby calls them "Burrow-ducks." I am rather in want of a little fresh air, and we shall study natural history after the hunter's fashion.

We are approaching the little fishing-town of Blakeney, and you already perceive a change in the scene. It is a good great-coat colder than at home; and the air is more than transparent. It illuminates the landscape, as if there were some bright medium between it and our eyes, as there is, in truth. These hills are steeper in their declivity than those we are accustomed to: our gravelly crag would not lie at so great an angle to the horizon, but would have slipped down before it became covered with herbage. The material here is well-worn pebble-stones and coarse shingle. You may remember that hills composed of loose matters have a slope corresponding to the stuff they are made of. The ashy cone on the top of Vesuvius is an example which my legs have not even yet forgotten. Different heaps of different rubbish incline according to their own private methods of slope; as would different kinds of sand in different hour-glasses.

A way-side passenger has become a rarity. The few we do meet make a point of saluting us respectfully. Yonder, crouched in the hedge, with red hands and blue face, is a boy deputed to the office here called "keeping" crows. I wonder if he be the same, to whom his employer once shouted, "Well, boy, where are you going to now?" "Why, master, I ha' kept 'em in this piece till they ha' eaten it up good tidily clean. They ha' flown to the tother piece, and I'm now agoin', like winking, to keep 'em there." Observe, too, the cottage gardens. Their contents mark the neighbourhood of the sea. You might suspect it from the extra-bright colours of the few remaining flowers, and from the extreme luxuriance of those rosemary shrubs; but here you see, for the first time during our drive, that handsome plant, the Tree Mallow (*Lavatera arborea*), displaying flowrets not a few. Depend upon it, the "Missis" is finely proud of that ten or twelve-foot specimen. I envy it myself. Those next door are of the same species, though their foliage is so different. Before flowering, the leaves are ample, but when the plant attains its reproductive stage, they are much smaller. In either state it is ornamental, as you see; but though a British native, and even a member of the scanty Bass Rock flora, it is not generally known. Many an alien is more familiar to people who saunter in dressed grounds and trim parterres. In gardens it often remains some years without blooming, but dies in the winter after it

has flowered; for it is, or ought to be, naturally biennial. Seeds fallen in the ground from the parent mallow will keep springing up every season for a number of years: but the young plants are impatient of cold, except in maritime situations, and few survive, which may be the reason why it is so rarely seen inland. But a tolerable gardener would get over that difficulty.

At last we are arrived, and a queer-looking place it is! The town seems a *cul-de-sac*, with no thoroughfare. There is one, discoverable by the enterprising. The dull little two-storied houses, in the narrow street, stand staring full-visaged at each other, like partners in a country-dance, instead of boldly facing the wide extent of marsh, creek, sea, and sands, as you and I should place them, were we to engage one for a three-months' lodging. And, listen! A watchman's rattle! if watchmen had not been swallowed up by the police. Ah! look! it is a fish-cart from Sheringham. The "old chap," in Saxon (the "senile vendor," in Roman) English, distrusts his feeble voice to give due honour to his commodities, so, after a flourish on the rattle, "Haddocks! fresh haddocks!" is gasped forth in a faint and asthmatical cry. Oh! we are not on vulgar ground; though genteel people, dear souls! very rarely trust their precious selves to stand on the pebbly pavement over which we are passing.

"What do you want for this haddock? No. I will not give you more than threepence; if I stretch another penny, I'll have that nice 'But' into the bargain. Very well; we'll take these to B——'s, to be fried for breakfast. It will be a relief to Mrs. B., who does not expect us. Tell me; dare truly genteel people carry a couple of fish into an inn-yard between finger and thumb?"

But it is still too early to pay our respects to the Naiads, "and the nymphs who dance on the sands," though our jaunt has taken place at the best possible age of the moon. At Blakeney it is high water at six in the morning, three or four days after full moon and change. So, we can drop down to the sea and the extraordinary "meals," four or five miles distant by water, with the ebb-tide, and return with the flood in a conveniently-timed day. Before we need take boat there is time for a good walk. Almost every other path is under water, thanks to this pressing north wind, so we will follow the Marsh bank, itself a pleasing wonder.

D.

(To be continued.)

WILD BEES.

By H. W. Newman, Esq.

(Continued from vol. viii., page 422.)

APIS LAPIDARIA (RED, OR ORANGE-TAILED BEE).

THIS is another beautiful species of wild bee very common in England. It forms its nests sometimes in old walls, heaps of stones, &c., or in the earth, generally a couple of inches only from the surface. The female, or queen bee, is large, very black, and hairy, with the three last segments of the abdomen red, or deep orange; the male is smaller, quite differently marked, being nearly all yellow, except the abdomen, which is red; the worker is a smaller bee, and marked the same as the queen. This is a very common bee in some parts of England, and on the continent, but I never saw one of this species in any part of Scotland, though there is a variety of it differently marked, with nearly the same habit in every respect, most frequently found there in old walls; they go by a very vulgar name among the lower orders in the north.

Of these (Red-tailed) I have taken many nests. This is easily done, as they are mostly on or near the surface of the ground, but out of the reach of the tread of cattle. My method is to lay the nest bare in the course of the day, and after sunset, when they are all quiet, to go with a small box, and lift the whole of the nest, combs, bees, &c., all at once, and cover them up for the night. It will amply repay any one curious in these trifles to watch the exit of the workers in the morning, when the aperture is opened, and they find themselves in a new situation; the care with which they survey the entrance one by one, the slow and cautious manner in which they take their first few flights, is most

admirable. Surely no one who observes this can for a moment suppose that the bee finds its way to its hive, or nest, mechanically, without full observation.

The males of the *Apis Lapidaria* have precisely the same habits as the two last described species; these bees leave the nests a few days after they are hatched (guided much by weather), to become wanderers like their congeners. They voluntarily leave, and may be seen flying from thistle to thistle, in their lively liveries of yellow and red.

Three years ago, when at Weymouth, I met a gentleman and his little boy, who were amusing themselves at a nest, killing the workers of this species with a shoe; this was in September. I civilly asked him why he killed them; his reply was, that they had some honey. The nest they had found was at the bottom of the cliff. I caught several of the workers with my naked hand, at which they were surprised. I assured them they were quite harmless, and convinced them that it was too late in the season to find the cells full; they became converts to my opinion, and desisted from destroying them. I have opened and examined hundreds of nests at the end of August, or beginning of September, and never found any honey. They appear to consume it always before the end of the summer; probably it is not wanted after the hatching is over, for as the wild bees are dormant through the winter they require none. We walked a few hundred yards together, and I caught several of the drones from the thistles, and he observed how different they were in appearance, and wondered none had gone into the nest, nor come out while we were there. I told him the reason of this, and that they never returned.

I was at Dieppe, in Normandy, in August, 1843, where I remained a day-and-a-half, on purpose to examine the wild bees in the country near. I found the same species exactly as in England. By far the majority were the Red-tailed, and the *A. Terrestris*. I met a number of French school-boys amusing themselves in the cruel practice of killing the wild bees and extracting their honey-bags. They certainly were adepts at catching them by the back; but when they saw me take several drones in my hand, and pull them by the legs and wings, they began to think I had some magical power, and it was with difficulty I could persuade them that the drones had no stings.

There are several more species of the wild bee in Britain, varieties of those which I have described, but they have all the same habits as to the internal economy of the nest—the drones all leaving without the faculty of returning; and each of the males of all the species make a round of visits, in fine weather, in the early part of the day, to particular spots; and each species varies its flight in this respect on the ground in a manner that a little resembles the workers. I need scarcely add, that none of the honey cells of any of these bees are sealed like the hive bee. The *Apis Lapidaria* is the handsomest of its congeners.

(To be continued.)

ROOKS AND PHEASANTS.

SOME correspondents have frequently asked for advice how to establish a rookery. The reply has been, to set rooks eggs under a magpie, who happens to have built in a favourable situation for a rookery. Assuming that you could get three or four pairs of magpies to build in the same spot near together, the plan would seem plausible, for a pair of rooks will seldom stay; they join other neighbouring flocks; but three or four pairs (if thus hatched and reared) would form a little community of their own, and probably might stay. But the difficulty is to get a magpie to feed a rook. I have known the experiment tried more than once, and the magpie has always deserted the rooks, and starved them, just as the black fine feathers appeared. A magpie is a most curious and sharp-sighted bird, and is not easily imposed on. Rooks, it is true, have a great attachment to the place of their nativity. Not farther back than twenty-five years ago, I remember that a pair of rooks built annually, for several years, on a single tree, in the Royal Hotel yard, and another pair on a tree in Edmund-street, both places then being, as now, in the very centre of Birmingham, but they never staid after their young could

fly. There are two rookeries near my present residence, and one is now altogether deserted in the winter, and is used in the breeding season only, I presume for the sake of the old nests, and by those birds who were bred there.

I have tried to rear young carrion-birds from their unfledged state, and they generally have lost the use of their legs when about fledged. I attribute it to a mistake in feeding, or in the food itself. If I wished to try to raise a rookery, and had a very suitable wood of trees, for they must be high, and a good many of them together, I would get some rook's-eggs, and set them under a bantam or light hen, and would try to rear the young by hand, in a place made amongst the trees, and I would turn them out as I would young pheasants or partridges, when they just began to peck; or the nests themselves might be robbed of their young when hatched, but you must recollect that you can never tame any bird or animal half so well after it has once opened its eyes upon, or been fed by its own parent, as you can by never letting it know any fostering hand besides your own; but the experiment of making a rookery is a very doubtful one.

One word to sportsmen on rearing pheasants, the result of experience. Do not turn up your tame or caged hens in your woods in the spring, to be eaten by foxes and vermin, and avoid putting a tame or caged cock pheasant with your hens to spoil their eggs through incompetency. Crop the hens wings, and put them in a wired place, open at the top, where the wild cock pheasants can have access to them. Then sit off the eggs under a hen, and rear in the usual way.

A WORCESTERSHIRE MAN.

TO CORRESPONDENTS.

** We request that no one will write to the departmental writers of **THE COTTAGE GARDENER**. It gives them unjustifiable trouble and expense. All communications should be addressed "To the Editor of the Cottage Gardener, 2, Amen Corner, Paternoster Row, London."

PRESERVING BALSAMS BY CUTTINGS (J. B.).—There is nothing new in this. The difficulty is to keep the cuttings healthy over the winter in a cool greenhouse. Place them at the warmest end, and if even then the cold should seem too much for them, put the glass over them, under which you struck them. Give little water, but keep them from flagging. A little labour, and you will be rewarded with compact bulbs, very full of flowers.

CALCEOLARIA SEED (A Subscriber).—Your greenhouse would have been quite sufficient for this. No stove heat is required. September is the best month in the year to sow, &c., but as October will be progressing before you see this, we would almost advise you to wait until February, then proceed as follows:—Fill a pot or pots half full with drainage, then with sweet soil, somewhat rough, to within three-quarters-of-an-inch of the top, then fill with half-an-inch more of fine-sifted soil—if a little peat in it all the better—press it down, and then set the pot over head, for ten minutes, in a pail of water; take it out and let it drain for at least twenty-four hours; then place the smallest quantity of fine sandy soil on the surface, press it gently and evenly down, and on this sow the seeds very thinly; then scatter over them a film of dry fine sand, and press again. Put a square of glass over the pot; on this glass place a little damp moss, and set it in a shady part of the greenhouse; remove the moss as soon as the plants appear, and give them a high position, allowing the glass to remain until the plants are some size. They are impatient of water until they are pricked off; and to avoid watering, you will succeed better by plunging the pot into a larger one, and filling the space between with moss, which you can keep moist.

GESNERA ZEBRINA (T. M. W.).—This being in bud, and looking healthy, will no doubt bloom, if you give it a temperature from 56° to 70°. We frequently have it in a glass case in summer, a greenhouse in autumn, and a plant stove the most of the winter.

FUCHSIAS GROWN IN POTS ON A SINGLE STEM (E. C. S.).—You have not told us your advantages. Keep them anywhere during the winter, free from frost, and just not dry, but moist rather than wet. Then cut down in spring, if you want a bush, or merely cut-in the side-shoots, and shorten the top one if you wish a Pyramid from a single stem, and repeat when the shoots have broken a couple of inches, and grow slowly, if you want a robust habit. You may prune in a month, if you like, but we should prefer spring for getting some nice cuttings, if you wanted them. See some hints by Mr. Fish, to-day.

NIGHT-BLOWING CEREUS (Legtonensis).—This is almost as hardy as the rest of the Cacti that will stand well in a greenhouse in winter, when kept dry, and in a state of rest. In such circumstances, it would require the warmth of summer to open its blossom. As to whether *Nematanthus longipes*, *Eschynanthus javanicus*, and *Bignonia insignis*, are suitable stove plants for exhibition, we must reply that we do not know the last, and are not sure we know the second; but all the *Eschynanthuses* are good when well grown. The *Nematanthus* we have had

in bloom for long periods, but scarcely profuse enough to be fit for an exhibition-table, but we did not give it much attention. The long flower-stalks give it a very singular appearance, when seen suspended from the branch.

TWENTY STOVE PLANTS SUITABLE FOR EXHIBITION (Ibid).—The following we think will suit you:—*Allamanda cathartica*, *Allamanda Schottii*, *Æschynanthus speciosus*, *Æ. longiflorus*, *Æ. miniatus*, *Aphelandra aurantiaca*, *Begonia cinnaburina*, *B. fuchsoides*, *Cassia corymbosa*, *Chirita Moonii*, *Clerodendron fallax*, *C. splendens*, *C. Kämpferii*, *Dipladenia crassinoda*, *Franciscea confertifolia*, *F. latifolia*, *Gardenia Stanleyana*, *G. Devoniana*, *G. Fortuniana*, *Glozinia grandis*, *Hoya Bella*, *Ixora coccinea superba*, *I. javanica*, *I. grandiflora*, *Medinilla speciosa*, *Rondeletia speciosa major*, *Stephanotis floribunda*. Take only one of a genus if it suits you, and add, *Gesneras*, *Glotinias*, *Achimenes*, and *Begonias*, as many as you please.

PIT FOR FORCING, PROPAGATING, &c. (B. A.).—We might make an instructive article upon the subject of your pit, ten feet wide, twenty-five feet long, and divided into two divisions, but we cannot answer your questions at large, so as to be useful to others, without a drawing. Let the following for the present suffice. 1 and 2. If your roof at the apex is either a foot higher, or the walls a foot lower, the angle of inclination will be better. 3. Depth of earth two feet. 4. Size of ventilators in front and back walls opposite each light, twelve inches by six inches, but at the front and back sashes more. These, though useful, will not be *absolutely* necessary, but the one opening into the hot-air chamber, and the other over the pipes at back, air may be safely admitted, when it would not be proper to move the sashes. 5, 6. Four-inch pipes will not be too large to heat the tank, though three-inch would do. These cemented troughs *are* useful, but we have no difficulty in getting moisture, by placing open rubble over pipes, and throwing in water when necessary. 7. We would use three, instead of two-inch pipes, for top dry heat, as the water circulates languidly in two-inch pipes, and if we had them at all, we would rather have them in front, or round the house, instead of at the back, as this of itself would preclude your placing according to question 9. Peach-trees against the back-wall, which, however, would not answer so well in such circumstances as vines and cucumbers. We do not see how you are to have additional dry heat from your tile drain 8, in front, as that communicates with the open chamber over the gutter, as well as the opening in the side, 7, to admit moist air. Now, by sinking your floor, for supporting the bed, some twelve or eighteen inches nearer the gutter, and we suppose this floor to be of slate, or some analogous substance, you might still have slides in the side for moist air at will, and then shafts all round communicating with the flooring would give you dry heat at will, besides enabling you to have plenty of rough material, such as brickbats, charcoal, &c., below the bed of earth. With such contrivance, unless you wanted to force plants and melons very early, the two four-inch pipes would be sufficient, especially with a canvass covering in severe weather. 8. The boilers will be nothing too large. 10. Glass, 16-oz. will not be too strong for panes forty inches by twelve inches; but why have them so long; just think of having such a thing as a crash, and the expense and trouble of replacing them. On the whole, we do not approve of your arrangement. Your pit over the gutter or tank is six feet wide, abutting on the front-wall, leaving four feet behind, you must open your front sashes to attend to the management of whatever you have. Why not place the pit in the centre, five feet wide, with two-and-a-half feet wide paths, back and front. You would thus have the whole place at command, and find yourself quite at home in the worst day, as well as the finest. Before building, examine a most economical arrangement of a house, given by Mr. Fish, at page 337, of our second volume. That house still answers admirably, the gardener does little wonders with it. If, however, you are wedded to your present arrangement, you might have a pit eighteen inches wide, and two feet deep, placed over your pipes at the back-wall, and there you may grow vines or cucumbers, to cover the wall, and hang from the hipped roof.

HOLLYHOCKS.—A *Constant Subscriber* recommends *Queen of England* (Chater and Son); delicate pink; very fine; beautiful. *Aurantia* (Rivers); salmon and orange; beautiful. *Obscura Suberba* (Chater and Son); silvery-shaded puce; a decided improvement upon *Obscura*. *Beauty of Haverhill* (Chater and Son); silvery-lilac; beautifully veined. *Napoleon* (Powis); slate, edged with light; fine. *Bella Donna* (Woods); white; one of the best out. *Meteor* (Bircham); crimson; fine. *No. blissima* (Chater and Son); rosy-red; mottled and veined; fine. *Rosy Queen* (Chater); rosy-blush. *Lady Cullum* (Chater and Son); rosy-crimson, glowing as if shot with purple; fine. *Susannah*; creamy-white; very fine. *Abriote* (Chater and Son); colour apricot; fine shape; large size; a noble flower. *Surprise* (Chater and Son); rosy-crimson; fine. *Journ of Arc* (Parsons); silvery-blush; very fine. *Yellow Model*, or, rather, *Primrose Model* (Bircham); this is very fine.

PROLIFIC DUCKS.—Mr. Edwards, Station-Master at the Jynderhurst-Road Railway Station, Hants, has a couple of ducks of the pure white Aylesbury breed, which have laid this season the prodigious number of 261 eggs. One of them laid in daily succession 146 eggs; and she is now running about with a brood of 12 young ones. The other laid 115 altogether; and she has now her second brood, having brought up her first brood of 13 early in the summer.

NEW SYSTEM OF SWARM-MANAGEMENT.—A *Country Curate* says, "I have been all along puzzled to account for the rather peculiar failure of "B. B.'s" trial of the new plan; but at last he has furnished us with some clue to the discovery of the probable cause. He had not learnt his lesson with sufficient care, when he applied himself to give my plan a trial. I have never myself stopped up a hive "from twenty-four to thirty-six hours," (from which a swarm had issued naturally) "as soon as the swarms had left the hives;" nor do I remember any where to have recommended such a treatment! I have said, indeed, that it may be well to stop up such a hive for a few hours on removing it to a fresh stand, but I have generally left my old hives so treated quite open from the first! To stop them up, however, for such a length of time, so full too of bees as they still usually are, after the issue of a natural swarm, I should at once have deemed a most mistaken method of proceeding. It is far otherwise in the case of a stock from which an artificial swarm

has been taken. In this instance there are usually but a *very small* number of bees left in the hive, the drones are mostly all in company with the swarm, and there is *no royal brood* to suffer. But in a stock from which a natural swarm has issued, many (perhaps most) of the drones remain. This, from the nature of the case, we might expect; not only so, there are usually many bees left, and above all, there are young royal queens, perhaps all in a state, and of an age requiring the most assiduous attention. Now what follows in both instances where the old stocks are shut up for so long a space? In the one instance, where the swarm was forced out, the temperature, owing to the paucity of bees, can seldom rise, from the necessary agitation within, to any very inconvenient height; at all events there is *no royal brood* to suffer. In the other case, however, when the swarm issued naturally, the heat from the large population might be expected to rise to a very dangerous height, and it would be almost sure to follow that the royal bees still in the grub state would suffer from that, or from neglect. This, to me, appears to afford quite a sufficient explanation of "B. B.'s" failure. It is the *management*, not the *system*, that is at fault here. But, moreover, I should very much question the policy of "running honey" out of the old hives, unless in a *very* thriving condition. I have never advised it. No doubt, too, the failure of "B. B." must be put down in part to the *very bad* season we had almost everywhere in June. Few mid-June swarms or their parent stocks will be found to have done anything this year. I shall be obliged to "B. B." to give us his opinion of the value of the above remarks. I cannot make out "H. S. N.'s" observations. He is not particular enough in narrating his facts. For instance, is he speaking of the stock or the swarm when he says, "I could not by any means induce them to work in the super?" "No. 3 natural swarm" could not possibly have come out of the stock, in whose place it was put, else there would have been no such fighting as he speaks of. The "fighting," which he says he has seen "more or less at all the swarms that have been put where the stock formerly stood," must have been only in appearance. I have never observed it. It is a *bad* sign to see drones in September, but worse in October. If any are seen now, fumigate and plunder.

VEGETABLE MARROW, &c. (Rosasolis).—It is Vegetable Marrow, and not *Mallow*; and is a kind of gourd. *Ixias* and *Sparaxis* are propagated both by seeds and by offset bulbs; and both ought now to be potted or sown in pots, in good turfy peat, with a little sand, and placed in a cold pit, or on a shelf in a greenhouse; the soil to be kept moderately moist all through the winter, and free ventilation whenever the weather is mild.

BIGNONIA RADICANS (Ibid).—It requires to be close pruned like a grape vine; and, after it comes to a flowering age and strength, it is generally a free bloomer on a south wall, or inside a cool greenhouse in less favourable situations. Can any of our Irish readers tell him what is the right name of a plant there called *Melidore*?

FUCHSIAS AND GERANIUMS (R. E. S.).—The Fuchsias will stand out with a slight protection from frost, and all your old Geraniums must be taken up, their green tops cut off, and the hard bottom parts and roots, after being partially dried, may be packed in a box or hamper with dry fern or hay, and put away from the frost like so many potatoes; but look at them from time to time, to see that they do not turn mouldy. Cuttings will do no good now.

LIST OF BULBS (S. S. S.).—We shall begin to analyse your bulb list immediately, and we hope between us to be of great service to many of our readers. Accept our best thanks for your share of the undertaking.

FLOWER-GARDEN PLAN (J. H. N.).—Your plan will be engraved as an example of a very useful and easy way of managing such a space. As to your *Allamanda*, with seven upright shoots, two feet high, cut four of the weakest shoots down to within two joints of the old wood, and the other three cut to one-half their length; this pruning to be done in March, as soon as you perceive the least appearance of growth; do not give the plant much water all the winter. A good gardener would prune so weak a plant of *Allamanda* at the end of this month; keep it nearly dry all the winter, and "set it to work" in a hot-bed by the end of February; shake away the soil from the roots on the first move of growth, trim the roots, and put it in a smaller pot, force it vigorously for three months, and give it two, if not three, shifts before the end of June, and would have it in bloom nearly by that time; that way would be most dangerous to a less experienced person.

GARDEN NEAR GLASGOW.—J. C. says: "In our garden on a south wall we have *Ceanothus puniceus* (the largest I have ever seen, and a perfect picture in April and May), *Acacia armata*, *Aloysia citriodora*, and a great variety of Tea and other Roses, all of which stand the winter without any protection. Fuchsias grow with us to an immense size. As I have noticed several inquiries in THE COTTAGE GARDENER regarding the *Noisette Rose Solfaterre*, I may mention that we have a plant covering a large part of the front of our house (I say our, for it is my father's, but my brother and I are the gardeners!), which has been in constant flower since the beginning of May last, and still showing buds; it was not pruned at all this spring. We have also had some very fine flowers on *Cloth of Gold*, budded on the Crimson Boursault. All the above are growing in a well-drained border, composed of peat, loam, and sea-sand, the former predominating. In the greenhouse, we intend growing Tea and other Roses for spring and late autumn flowering, and we purpose planting them in a border formed all round the house, instead of growing them in pots, as our time being limited would not admit of the constant attention necessary, as to waterings, &c., were they grown in the latter way. Although Roses are principally what we intend growing, yet we purpose having a selection of other suitable things, and I shall be glad if you would furnish me with a list of such things (including climbers), as you think would be likely to stand the winter without fire-heat; and here I fancy I hear you say—But why not have a flue or brick stove, in case of severe frosts? Well, because as we are residents in town during the winter months, and leave no one who understands the matter to attend to the fire, we thought we should be less likely to have our hearts broken by trusting to Jack Frost, than by leaving fire-heat in the hands of a bungler. Don't you agree with us?" [Yes; certainly.]

GRAPE FOR A COLD GREENHOUSE (J. C.).—The *Royal Muscadine* is the best white, and the *Hambro'* the best black, for such a house as

yours, on the coast of Loch Long, beyond Glasgow. If you plant these vines, you must give up all ideas of other climbers for this house, except, perhaps, *Bigonia* or *Tecoma radicans grandiflora*, which requires the very same treatment in every respect as these hardy grape vines. We know Glasgow Green, and both sides of the Clyde below it; also some of the "bunglers," and best men in these parts; and, as very little can be done on the coast until you go down next May, you will excuse us for not giving you a list of suitable plants for summer culture until we consider "a wee." Some of our London readers, who know as much of Loch Long as of Timbuctoo, will be astonished to read your account of the gardening on that part of the west coast of Scotland. It will be no surprise here, however, to hear of the sons and daughters of wealthy fathers being so much in their garden.

ROSES ON TURF (E. S. F.).—Standard roses will not do so well in groups when the roots are covered with grass as when they have an open circle or bed. A group of standard roses on grass, by the way, is one of the most frightful things that you could devise or think of for a flower-garden; something as if Her Majesty, while at Balmoral, had all the ladies of her household dressed in kilts of the royal tartan. Rather have them planted in this wise—three tall standards in the centre; five half-standards round them; and ten or a dozen strong dwarfs outside of all. These dwarfs should be worked plants on six-inch stems, and the grass might be laid quite close to the stems of the outside row; then, from May to November, who would know but your roses were "on grass?" All the plants or kinds of roses in a group of this kind, should be of equal strength, so as to keep up the uniformity of the whole.

FLOWER-GARDEN PLANS (Ignotus and Others).—One will appear this month, and will be followed by others in a monthly series.

HARDY FERNS (Tom Pouce).—As you intend transplanting native ferns from your own neighbourhood into your rock-work, which you are now constructing, you may begin at once, and go on with them, to the end of next March, as the weather allows. The smaller kinds you will easily remove, as their roots run near the surface; but the roots of the great, strong-growing ferns run very deep, and they must be trenced out to do much good; but if so treated, they want no balls with them. We have known scores and scores of pounds wasted in removing thick, square pieces of turf, or balls, from native fern brakes to "inoculate" parks and rough pieces in pleasure grounds, such balls carrying only the buds and leaving the roots behind. When a piece of fern land is broken-up for cultivation, the farmer will tell you that the roots of ferns are as bad to get rid of as the roots of docks, and this ought to teach us gardeners that the large, common ferns come from pieces of the roots, and so we ought to know better than plant only buds and balls.

MOSS ROSES (An Old Raven).—You must take them all up early next month, trench the ground two spits deep, mixing a good quantity of rotten dung with it if the roots are long, black, and fibreless, as we expect they are, cut them back one-half, and cut in the branches quite close to the old wood, and if the old wood is long, cut one-half of the shoots to near the bottom; then replant them, and put some littery dung on the surface of the ground to mulch them, and next May, when you see the leaves coming out, begin to water them freely, and let them have some weekly to the end of July. If they come up strong, give liquid manure occasionally.

FLOWER GARDEN PLAN (W. T.).—The planting is unexceptionable, and as your *Heliotropes* agree with the *Ageratums*, there is no objection in the least against the mixture, and the centre bed is just the right place for them; but this is the only bed in your garden that is fit to be seen; the four flanking it are *dumpy*, the rest quite frightful. We have not seen the work you allude to.

COCHINS v. SPANISH.—Q. in a Corner says: "I like the spirit in which 'Gallus' writes; agree with him in general as to the excellence of Dorkings, but dissent from his conclusion *in toto*. Having kept almost every variety of fancy poultry during the last thirty years, and paid great attention to their consumption of food, always feeding them *myself*, I have arrived at the conclusion, that if there is any difference in proportion to size, Malays are the *greatest* eaters; that Cochins do not eat more than Spanish or Dorkings, in *proportion* to size; that they are *easily* satisfied, and *often* leave part of their allotted food; and, in opposition to Mr. Bailey, no mean authority, I find they fatten *rapidly*, and that the short-legged variety lay on much flesh on breast and wings. As to their excellence as a table fowl, much, I think, remains to be proved, as the price has hitherto proved a bar to a fair trial on a large scale. Allow me to say, that to sit down to a poultry-dinner, knowing that they are Cochins, and having a preconceived notion that they are *not very good*, is *not a fair trial*. Will 'Gallus' or Mr. Bailey, who so kindly comes to his rescue, allow themselves to be blindfolded, and in that state sit down to table, having slices of poultry set before them, and then say whether it is Spanish, Dorking, or Cochin, *from favour only*? If so, I will confess myself satisfied, but not till then. Is there not in the name of Dorking a charm that would give relish to *any* fowl sold under that name? The only difference I could ever discover, was a flavour in some Cochins approaching that of game, which can hardly be an objection. I know of a case where a very knowing gent sat down to dine off a large Shanghai cockerel, dressed as a Turkey poul, and yet could not discover the cheat. So much for *flavour*. This, however, would go to prove that in this breed there is a little difference in flavour; but I write for information, not victory. As to *productiveness*, there is certainly no comparison between them and Spanish, as far as my experience goes; none in the ease with which chicks are reared,—the Spanish being proverbially difficult to rear. The opinion of some of the oldest and best fanciers has been sought, and it fully coincides with the above. One, when reading the article about the excellence of Spanish fowls as *layers*, laughed outright, and said that they were anything but good, when compared with Cochins."

RED SPIDER (A Twelve-month Subscriber).—We take it that by "Garden Spider," you mean *Red Spider*, and if so, tobacco-smoke will not kill or drive him away; neither will your other remedy,—sulphuring the house,—affect the *Dry White Scaly*, or the *Soft Mealy Bug*, if they are included in your "several other insects." Nevertheless, it is a very

good plan to turn out all plants once or twice a-year from a greenhouse, or from pits, and burn sulphur in those structures, and to keep the doors and ventilators closed for a day or two afterwards. Then, after a few hour's free admission of fresh air, the house or pit is safe enough for any plant. If you use grass as you propose, the expense of keeping it in order will be double what it is now, but your place would look much better. Circles, not more than four feet through, and ovals, eight or nine feet long, are the only shapes suitable for such strips of ground.

EDGING PLANT (Lover of Flowers).—We do not know "a hardy herbaceous perennial that will be in bloom from the 1st of June to the end of September, and not to have pink flowers."

CHINA IRIS (W. G. N.).—It is not at all a fit plant for pots, unless you were an expert gardener. Place it under a west wall, in rich light soil, and it will take care of itself, and blossom there; it is hardy enough, and wants no protection.

PEAT (Y. Z.).—How can we tell you what to put it to, unless we knew what plants you cultivate, and the nature of your soil? It is not used for *Geraniums*; but is especially required for *Heaths* and *American plants*. Keep it under cover. *Crocuses* do not require manure, unless the ground be poor, but to be grown in a moderately rich, well-drained, light soil.

PHLOMIS FLOCCOSA (Subscriber).—This is a half-hardy evergreen, and is so described in *The Cottage Gardeners' Dictionary*, if you read the description there given. To avoid numerous headings, all the half-hardy species are put together. You are there told its average height, colour of flowers, time of their being open, native country, and date of introduction. We have little more to add to such history. It is called *floccosa* on account of its woolly branches. It flowers usually from July to October. There is a drawing of it in the *Botanical Register*, t. 1300.

EQUATION OF TIME (Cockerham).—We believe it is right; we are indebted for it to the *Gardeners' Almanack*, and for that the Stationers' Company employ an astronomical authority.

ROSES PEGGED DOWN (A Recent Subscriber).—We have set our face against the plan of pegging down Roses altogether, for reasons long since explained; therefore, we said nothing about it in *The Cottage Gardeners' Dictionary*. Super-phosphate of lime is good for Roses, no doubt, but good old cow-dung, we think, is far better for them; but try the two, and let us hear the result.

POTATOES IN COLD, WET CLAY (M. R. P.).—Do not plant your potatoes in such a soil until February. Until then keep them buried in layers alternating with coal ashes, or sand, in a cool, dry shed. When you plant, do so in beds about four feet wide, with deep alleys between to drain them. Lime, bricklayers' rubbish, coal ashes, and tan, would be good applications to such a soil. We should plant Ash-leaved Kidneys.

SAIL-CLOTH FOR FRUIT-TREE SHELTERING (A. Z., W—n).—You may obtain this of Messrs. T. and D. Henry, 44, Mark Lane, London.

PLANTING POTATOES (K. H., Dublin).—We regret that the gentleman who instituted the experiments is dead, but we are promised a report of their results.

LIVER-COMPLAINT IN RABBITS.—In number 205, Sept. 2nd., "Amicus" asks if any reader knows a cure for liver-complaint in rabbits? I believe it to be caused by damp, and want of fresh air, also by moist or unwholesome food. I have had rabbits killed by it, that have thriven well in an open grass-plot, till a wet week came on. I think it may be known by the rough and lean appearance of the animal, and I have cured it by keeping them clean and dry, and giving them salt in their dry food. I do not think that the rabbits often grow out so fine afterwards if they do it bad.—B. P. B.

COCHINS NOT FATTING.—I must beg to differ from "Gallus," and Mr. Bailey, respecting Cochin-Chinas not fattening. My young fowls have always been exceedingly fat and delicious eating, and have been pronounced excellent by all that partook of them. Mine, however, are not, I think, the largest sort, more like what "An Old Subscriber" calls the Lovell Cochin-Chinas. So the varieties may differ in their gastronomic qualities.—B. P. B.

PICKLED SAMPHIRE (E. S. D.).—Well sprinkle your fresh-gathered samphire with salt. Cover it with spring water, and let it stand twenty-four hours; then put it into a brass pan, with another handful of salt, and cover it well with vinegar. Cover the pan close, and set it over a slow fire until green and crisp, at which moment take it off, for if allowed to get soft it will be spoiled. When cold, tie over your jar both a bladder and a leather. Samphire may also, we believe, be kept all the year in a strong brine of salt and water, throwing it into vinegar just before you wish to use it.

NAMES OF PEARS (Mr. Watson).—No. 1. Marie Louise. No. 2. Beurré d'Aremberg. No. 3. Marie Louise. No. 5. Easter Beurré, small, bad specimen. No. 8. Napoleon, ditto. No. 13. Nelis d'Hiver. No. 14. Glout Morceau. No. 20. Duchesse d'Angoulême. No. 21. Nelis d'Hiver.

POTATOES (E. O.).—We should grow no other Kidney Potato than the *Ash-leaved*; and no other round Whites, than *Rylott's Flour Ball*, *Fox's Early Delight*, and *Hoptown Early*.

NAMES OF PLANTS (Tyro).—*Escallonia montevidensis*, or *floribunda*, for we believe the two species are identical. It grows without shelter in the Dean of Winchester's garden, at Bishopstoke, Hants. (*Rev. R. M. E.*)—The plant found by your botanical friend in a field near Cloyne, in Ireland, is not a *Verbascum*, but *Celia Cretica*, a half-hardy biennial native of Crete, but growing like a weed in the garden of the Warden of Winchester College. It must have escaped from some garden.

LONDON: Printed by HARRY WOOLDRIDGE, Winchester High-street, in the Parish of Saint Mary Kalendar; and Published by WILLIAM SOMERVILLE ORR, at the Office, No. 2, Amen Corner, in the Parish of Christ Church, City of London.—October 21st, 1852.

WEEKLY CALENDAR.

M D	W D	OCTOBER 28—NOV. 3, 1852.	WEATHER NEAR LONDON IN 1851.				Sun Rises.	Sun Sets.	Moon R. & S.	Moon's Age.	Clock bef. Sun.	Day of Year.
			Barometer.	Thermo.	Wind.	Rain in In.						
28	Th	St. SIMON AND ST. JUDE.	30.100—29.576	54—39	S.W.	33	49 a. 6	39 a. 4	5 a. 18	15	16 7	302
29	F	Virginian Creeper leafless.	29.419—29.305	48—30	N.W.	02	51	37	5 39	16	16 11	303
30	S	Woodcock arrives.	29.599—29.424	49—35	N.E.	01	53	35	6 4	17	16 14	304
31	SUN	21 SUNDAY AFTER TRINITY.	29.612—29.602	48—32	N.W.	02	54	33	6 35	18	16 16	305
1	M	ALL SAINTS.	29.613—29.559	52—28	N.W.	—	56	32	7 15	19	16 18	306
2	Tu	Michaelmas Term begins.	29.550—29.336	50—31	N.	01	58	30	8 4	20	16 18	307
3	W	Lilac leafless.	29.920—29.759	45—26	W.	06	VII	28	9 4	21	16 18	308

METEOROLOGY OF THE WEEK.—At Chiswick, from observations during the last twenty-five years, the average highest and lowest temperatures of these days are 54° and 39.3° respectively. The greatest heat, 67°, occurred on the 29th in 1833; and the lowest cold, 20°, on the 3rd in 1845. During the period 90 days were fine, and on 85 rain fell.

BRITISH WILD FLOWERS.

BERBERIDS.—BERBERIDACEÆ.

(Continued from page 22.)

EPIMEDIUM. BARRENWORT.

GENERIC CHARACTER.—*Calyx* below the fruit, of four small, egg-shaped, concave, spreading, deciduous leaves. *Corolla* of four egg-shaped, equal, concave, spreading petals, opposite to the calyx. *Nectaries* four, one lying upon each petal, and nearly as long, pouch-like, blunt, equal, attached underneath to the *receptacle*, by one side of the orifice. *Stamens* with filaments, awl-shaped, erect, close to the style. *Anthers* of two oblong-oval, parallel cells, attached longitudinally to the inner side of the *filament*, below its summit, each cell opening by a valve, which bursts from the bottom and rolls back. *Germen* elliptic-oblong, with a furrow at the back. *Style* oblique, roundish, the length of the *stamens*. *Stigma* simple. *Pod* oblong, pointed, of one cell and two valves. *Seeds* numerous, unilateral, oblong.

EPIMEDIUM ALPINUM: Alpine Barrenwort.



Description.—It is a perennial. *Root*, creeping, slender, and thread-shaped, by which it increases rapidly. *Stems* about ten inches high, solitary, stiff, smooth, cylindrical, semi-transparent, three-branched at top, near the root scaly. *Leaves*; there are no leaves springing direct from the roots, but each branch bears one most elegant and delicate leaf, on a longish stalk, either once or twice subdivided into three leaflets. *Leaflets* hanging down perpendicularly, heart-shaped, ending in a point, about an inch-and-a-half long, but enlarging after the flowering is over, very veiny, saw-edged, and each tooth ended with a hair, pale-green above

and greyish beneath. From the point where the stalks of the subdivisions of the leaf join the footstalk common to them all, springs the flower-stalk, which bears a cluster of flowers about four inches long, the flowers scattered upon it widely apart, on three or four branchlets, each branchlet usually two-flowered. *Petals* four, dark-red, and contrasting strongly with the four large pale-lemon-coloured *nectaries*, which are full of honey, and very peculiar. *Stamens* short. *Anthers* with a taper point, and two lid-like valves. *Stigma* yellowish, encircled at the bottom by a red band. *Seed-vessel* a one-celled pod, with many seeds.

Places where found.—In thickets in some parts of Yorkshire and Cumberland; on Skiddaw; and near Glasgow and Edinburgh. Very rare.

Time of flowering.—May.

History.—This plant is included in the Tetrandria monogynia class and order of the Linnæan system. It is of such rare occurrence, and has only so comparatively recently been discovered in Britain, that many botanists doubt whether it is really a native of our islands. Gerarde, in his "Herbal," published in 1597, says, "This rare and strange plant was sent to me from the French king's herbarist, Robinus, dwelling in Paris, at the sign of the Black Head, in the street called *Du bout du Monde*, in English, The end of the World. This herb I planted in my garden, and in the beginning of May it came forth of the ground. Its seed came not to ripeness in my garden, by reason that it was dried away with the extreme and unaccustomed heat of the sun, which happened in the year 1590, since which time, from year to year, it bringeth seed to perfection." Johnson, in his edition of Gerarde's Herbal, published in 1636, says, "It groweth in the garden of my friend, Mr. John Milton, in Old Street, and some other gardens about town." This "Mr. John Milton" was the author of "Paradise Lost." Parkinson, in 1640, gives a very accurate description of the plant, but only mentions the mountain districts of Italy as its native place, and Ray, in 1688, says no more than, "I observed it on the Alps, not far from the town of Ponteba." Even as late as 1807, Dr. Martyn writes, that "Mr. Miller affirms that he received some plants of it which were found growing naturally in a wood in the north of England, but he was probably misinformed." Mr. Miller may, therefore, be considered its first recogniser as a native plant. It was certainly found by the Rev. T. Gisborne, in 1787, "in a very wild part of Cumberland called Carrock Fell," and by Mr. Robson, on Skiddaw, in 1795. Johnson seems to have named it *Barrenwort*, "not because that Dioscorides says it is barren both of flowers and seeds, but because, as some authors affirm, being drunk, it is an enemy to conception."—(Smith. Lindley. Martyn. Withering.)

A CORRESPONDENT (W. H. O.) writes to us as follows:—"The advantages of double-glazing are numerous, and among them are included the saving of mats, the saving of the time in covering and uncovering, the gradual return of light to the plants in the morning, the gradual withdrawal of the light at night, and the longer time the plants would have the light, *i.e.*, from earliest dawn to the latest daylight. Moreover, I think that the second glass may have the effect of correcting any fault

in the refraction of the upper glass, and thus prevent burning. I have six small lights, three feet by four feet, double-glazed, and on Saturday last there occurred a rather sharp frost; all my glasses were covered with white frost, with the exception of two places which exactly corresponded to panes which had been broken in the under glazing."

The two places on the outer glass were kept free from white frost by the rush of warm air against them

through the broken panes beneath, and affords strong evidence of the check to the escape of heat which a second glass affords. Let it not be supposed, however, that there ought to be any opening in the inner glass for the purpose of admitting warm air from the bed between the two glazings. So far is this from being desirable, that the panes of glass, both in the lower and upper glazing, should be puttied even between the laps, in order that they may be rendered as nearly as possible air-tight.

The philosophy of double-glazing shows that its power to protect from frost depends upon that tightness, for it is only air confined, or kept quiet, that is a bad conductor of heat, and air in motion carries off heat very rapidly. The most intense cold in calm weather was not a cause of suffering to Captain Parry's men when properly clothed at the North Pole, but the same degree of cold, when the wind was high, was not endurable, although the thermometer showed there was no lower degree of temperature—the air in motion carried off the heat faster. The same principle is in operation when a wet finger is held up to detect which way a current of air is passing, by its rendering one side of the finger colder than the other.

It is on the known fact that air is a non-conductor of heat, that double windows are employed in Russia to exclude the cold, and in the West Indies to exclude the heat. This is no anomaly, for to exclude cold is only another mode of expressing what is intended when we speak of keeping in the heat. In Russia they have to keep the room's heat from escaping into the air, and in the West Indies they have to keep the air's heat from getting into the rooms.

In double-glazing our garden frames, we have the same object in view as they have in Russia; and if the frames had double boards, or the pits double walls, as some ice-houses have, the cold could be excluded, so as to protect many more plants than at present we are able to carry through the winter without the aid of artificial heat.

Another advantage attendant upon double-glazing, besides those mentioned by our correspondent, is the prevention of "drip" within the frame, pit, or house. This is occasioned by the warm air, which contains moisture in proportion to its warmth, coming in contact with the cold glass, and there letting drop all the moisture it is not capable of holding at the lower temperature to which it was cooled by the glass. When the difference between the temperature of the glass and that of the air is great, the moisture is deposited, or let drop, in such quantity on the glass, that the moisture trickles down and forms "the drip." Now, double-glazing would prevent there ever being so great a difference between the temperature of the inner glass and the temperature of the air in the house, as to cause such a sufficient deposition of moisture as to form "the drip."

COVENT GARDEN.

SOME of our readers will be disposed to doubt the correctness of our observation, and the authority of these "city articles" of ours, when they see in Covent Garden fruits purporting to be varieties which we said two or three weeks ago were over for the season. But this is no uncommon occurrence; such modes of imposition having been practised ever since we have known the market, and, for ought we know, one which boasts of as great antiquity as that which we exposed last week in reference to the Elder berries. It may be laid down as a general rule, that whatever kind of fruit you ask for, you can have it. Jargonelles at Christmas, or even at Easter; Brown Beurés all the year round; Ribston Pippins *passim*; and "fine Burgamys," are among the leading articles with these very accommodating traders. Our readers must, therefore, be on their guard how they receive the assurances, and place too much confidence in these individuals. It would be wrong, however, to say that there is no confidence to be placed in any of the fruiterers, for we know that there are some of them who are of the highest respectability and integrity, and who would scorn to be concerned in such practices.

FRUIT.—There is still a continued abundant supply of APPLES, and at a somewhat advanced price; some sorts having made as much as 7s. 6d. per bushel. The general belief is, that Apples are a very short crop, and will, before the season is much farther advanced, be less plentiful than they now are. The sorts which have been most plentiful during the week are—*Ribston Pippins*, *Blenheim Orange*, a fine apple, but, generally speaking, not so large this season as we have observed it. The *Nonesuch*, *Winter Strawberry*, and *Beauty of Kent*, are among the leading sorts, as well as a few parcels of *Emperor Alexander*. In our report of the week before last, our printer's devil, who, like all other devils, is always up to some mischief, made us say there were Golden and Winter Pearmain's in that week's supply, whereas, in "the copy," we only mentioned the Golden Winter Pearmain. The Winter Pearmain's, so far from being in the market, are hardly gathered yet. This *Golden Winter Pearmain* is by some called "King of the Pippins"—a title given to it by a London nurseryman, who, either for the purpose of deceiving his customers, or with the view of retaining the sale in his own hands, applied to it this high-sounding name. Of PEARS there has been an abundance, particularly of *Marie Louise*, which has now become so common as to be met with on almost every fruit-stall in the streets. The *Bishop's Thumb* is also very plentiful, and we observed one or two parcels of the very old-fashioned *Messire Jeane*, which is one of those obsolete French pears that have been displaced by the new Flemish varieties. In the centre arcade were some of the finest *Duchesse d'Angoulêmes* we have ever seen; more like large pear-shaped gourds than pears; they were received from Guernsey. The *Catillac*, which is a stewing pear, has also appeared during the week, but, fine as they looked, there are some others which we would very much prefer to it for that purpose. The great objection to the *Catillac*

is its grittiness, and, however well-grown they may be, this is a characteristic which they invariably possess. If any of our readers are desirous of possessing an excellent stewing or baking pear, there are none which will give them greater satisfaction than *Bellissime d'Hiver*, *Flemish Bon Chrétien*, and *Vicar of Wakefield*; of the latter there have been some very fine specimens exhibited in the market.

VEGETABLES.—These continue plentiful. **CABBAGES** do not vary in price from last quotations, ranging from 6d. to 1s. per dozen. **CAULIFLOWERS** furnish a good supply, and some are of excellent quality, which make 2s. 6d. per dozen, but inferior examples are as low as 6d. **BRUSSELS SPROUTS** about 1s. 6d. per half-sieve. **COLEWORTS**, 1s. to 2s. per dozen bunches. **CARROTS**, of which there are some very fine samples of the *Long Surrey* and *Altringham*, make from 2s. 6d. to 5s. per dozen bunches. **TURNIPS**, 1s. to 1s. 6d. per dozen bunches. **ONIONS** are plentiful and fine, chiefly of the *White Spanish*, or, as it is sometimes called, *Reading* sort; they make from 2d. to 4d. per bunch. **SCARLET RUNNERS** are freely sold at 2s. per half-sieve. **ENDIVE** is very fine, large, and well-blanching, of the *Green Curled* variety, and was selling at from 1s. to 1s. 6d. per score. **CUCUMBERS** continue plentiful, at from 2d. to 6d. and 9d. each. **POTATOES** are rising in price. Fine *Regents* cannot be had, well picked and free from disease, under £7 per ton.

PLANTS AND FLOWERS.—The near approach of winter has banished flowers in pots, and their place is taken by grim, cemetrean-looking "greens," wherewith the Londoners may, for the next six months, adorn their halls and balconies. Of these we may enumerate nice bushy plants of *Laurustinus*, *Aucuba*, *Siberian* and *Chinese Arbor vitæ*, *Cotoneaster microphylla* and *buxifolia*, adorned with red berries, *Exmouth magnolia*, and *Tree Box*. The few **FLOWERS** there are consist of *Erica hyemalis* and *gracilis*, *Trachelium cæruleum*, *Sedum Sieboldii*, *Primula sinensis*, fine, large, fringed varieties, both red and white; *Yellow Pomponé Chrysanthemums*, and *Ivy-leaved Geraniums*. **CUT FLOWERS** consist of *Camellias*, *Ceanothus azureus*, *Cinerarias*, *China Roses*, *Bignonia venusta*, *Verbenas*, *Clove Carnations*, *Snow-berries*, *Fuchsias*, *Heliotropes*, and *Scarlet Geraniums*.—
H.

The following is a list of the *Horticultural and Poultry Shows* of which we are at present aware. We shall be obliged by any of our readers sending us additions to the list, and giving the address of the Secretaries.

HORTICULTURAL SHOWS.

BURY ST. EDMUNDS, Nov. 26 (Chrysanthemums). (Sec. G. P. Clay, Esq.)

CALEDONIAN (Inverleith Row), Edinburgh, Dec. 2.

HAMPSHIRE, Nov. 18 (Winchester). (Sec. Rev. F. Wickham, Winchester.)

LONDON FLORICULTURAL (Exeter Hall, Strand), Nov. 9+, 23, Dec. 14+.

NORTH LONDON, Nov. 23, Chrysanthemum.

SOUTH LONDON (ROYAL), Nov. 11+, Dec. 9+, 16.

† For seedlings only.

POULTRY SHOWS.

BIRMINGHAM AND MIDLAND COUNTIES, 14th, 15th, 16th, and 17th December.

BRISTOL AGRICULTURAL, December 7th, 8th, and 9th. (Sec. James Marimont.)

CORNWALL (PENZANCE), January 10th, and 11th. (Secs. Rev. W. W. Wingfield, Gulval Vicarage, and E. H. Rodd, Esq.)

DORCHESTER, Nov. 18th. (Sec., G. J. Andrews, Esq., Dorchester.)

HONITON, January 12th. (Sec. H. K. Venn.)

WINCHESTER, December 1st. (Secs. G. W. Johnson and J. Colson.)

PINES: THEIR CULTURE.

(Continued from page 26.)

Our readers will remember that in the preceding papers on this subject the matter was brought up to the point of structures, interior fittings, heating, ventilation, atmospheric moisture, shading, &c. Cultural matters come next, and we must begin with *the sucker*, which is the favourite mode of propagation. Space will not permit us to indulge in verbose details, neither are they needed; we may merely observe, that the sucker makes a good plant more speedily than the crowns or gills, and that it takes less room. Those who have dined at public tables in a crowded condition, and have thereby been well elbowed, will readily understand the difference between them; the crown, in consequence of its highly recurved foliage, is much given to elbowing; and were our good friend Beaton's Yuccas to produce crowns as well as suckers, ten to one he would prefer the latter, for their habits bear a great resemblance. For the information of those who do not well understand the technology of horticulture, it may be observed, that the *sucker* is a reproduction from the root, or lower portion of the stem; *the crown*, of course, surmounts the fruit, and *the gills* are little excrescences, which nature, in her sportiveness, causes to assume the character, and, indeed, possess the functions of real plants.

Now, as not every one who reads these observations can build a house at once, and plant these suckers out in soil, we will show how these suckers are cultivated in ordinary practice. Of course, they come to hand at various periods under ordinary circumstances—the greatest bulk generally when the fruit is cut. If this happen any time between October and February, many cultivators leave them on the mother plants, termed "stools," in this condition, until February. Many come to hand, however, through other periods, for some plants produce more suckers than it is expedient to have, and as these come at different periods, it is the practice with some to dibble them in the tan at the front of the pit or frame, just like a cabbage plant. Here they will speedily root, and may remain until there are enough to fill a frame, a pit, or a portion of such, or until some re-arrangement of the stock takes place, when it becomes the cultivator to work them in with his system. On these occasions they are mostly potted, and if good plants, will require seven-inch pots, well drained. They are now, of course, plunged in a bottom warmth of from 80° to 85°, and henceforth the usual routine of culture is practised. They are repotted or shifted, when full of roots, into pots a couple of sizes larger, and thence into their fruiting-pots, when under pot culture; the period of the last shift being partly regulated by the time the fruit is required. The latter may generally be expected about nine or ten months from the final shift.

Now, if any one about to commence the Hamiltonian system could lay hands on a lot of strong-rooted suckers from these seven-inch pots, they would be just the thing; they would be purchased at a moderate

price, compared with fruiting-plants. Another excellent plan would be to purchase stools as soon after the fruit is cut as possible, and to plant these out at once.

And here it is necessary to interpose a few special remarks, for the guidance of those purchasers who are not experienced in Pine-culture. The first is, to beware of insects; not to receive plants at a gift, if at all infested. We are led to these remarks in a more pointed way from the tenor of an enquiry or two recently addressed to THE COTTAGE GARDENER; the querist asking if the crowns of imported fruit would not be a good beginning for one just embarking in Pine-culture?

Certainly, such must appear very feasible and economical in the eyes of the unknowing, but it is both a dangerous and uncalled-for procedure. These crowns are for the most part three-parts killed by the ordeal they have passed; but even this is not the worst; they may be infested with scale, bug, or other insects; at least, they are to be regarded with a suspicious eye; and, moreover, they may not be of the kinds best adapted for a British palate, a British sky, or a British market. Let anyone suggest to a good gardener the introducing a lot of these blistered-looking apologies for a plant amongst his healthy, glaucous-looking Queens or Jamaicas, which, like Cæsar's wife, are above suspicion, and they will speedily see his hairs stand-on-end "like quills," &c. No; if any one feels desirous of trying an experiment in this way, let him make the attempt in some pit or house which may never compromise the general system of Pine-culture. And not only may the crowns or suckers from importations prove foul, but those from home-grown fruit also, although the latter is of somewhat rare occurrence now-a-days. An exceedingly jealous eye, must, however, be kept on them, and the best way for those who do not understand Pine-culture, is to employ some experienced gardener to select them.

In looking over Mr. Hamilton's notes, in answer to certain enquiries, we find that he strongly recommends old stools wherewith to commence his system. He says:—"Let the beginner commence with old stools, with one or more suckers on, and plant them out at once. If old stools cannot be had, let the suckers be stuck in at one end of the pit, in a compost two-thirds leaf mould, and one-third soil. After they have made one foot of growth let them be planted in fresh turf. A fourth-part of the bed would hold the suckers; when well rooted, let them be taken up and laid aside, and their compost can be spread along the bottom of the bed, and the fresh turf can be laid on the top for permanent planting, and then there is no loss of time." It will be seen here what stress Mr. H. lays on old stools, which, however, are not always attainable. It so happens, that they are the very thing that most gardeners on the old or pot-system throw away; the only misfortune being, that they are apt to strip away every sucker of any size previously, and in this case, several months may be lost—a most important affair.

Those about to build should immediately commence a sharp look-out, and, perhaps, the best way would be to offer nurserymen, in Pine-growing districts, a certain value per head, specifying kind, and making *thorough cleanliness* a *sine qua non* condition. As to time of planting, that is almost a matter of indifference. To those determined to build, we say, do so directly, and get the stools all at once, or by instalments, as you can catch them, good and clean, and at as early a period as possible, only take care that everything is ready to receive them.

It will be well here, for the sake of the tyro, to explain a few technical terms pertaining to the Pine in its various stages. Gardeners, in general, use the following to express the character of their plants:—

Small suckers.

Strong suckers.

Successions.

Strong successions.

Fruiting plants.

Fruiters.

There may be some little modification of these terms, here and there, but such, in the main, express these gardening conventionalities. Their meaning is as follows:—*Small suckers* are inferior suckers, or suckers from inferior plants, and are generally under a foot in length (this, however, is dependent on kind); and in diameter, at base, a little over an inch. *Strong suckers* may be characterised as of at least double that strength; the former, by our potting-men, would be put in a five-inch pot, the latter in a seven-inch. When established in their pots, and full of roots, they become *successions*; those in the five-inch pots, the ordinary *successions*; and those in the seven-inch, *strong successions*; providing they have been flourishing. We come now to *fruiting plants*, and these, of course, mean plants prepared to show fruit, although such is not always the case immediately. There are certain marks whereby practical men can tell almost to a certainty whether the fruit has commenced rising, and when in sight it is called "a show." The general character of the plant, just previously, becomes considerably altered; it looks more compact, the outer leaves cease to elongate, or nearly so, whilst those of the interior advance, and also multiply as they advance. The whole plant, by this time, if robust, will, if pulled by the hand, appear firm in the soil as a stout shrub. *Fruiters* are those in which the show is complete, and this title continues up to the time when they begin to change colour, when they become *ripeners*—a term which needs no description.

Having now brought up the subject to what may be termed a fair beginning, as to cultural matters, we may just suppose a house of the kind built and ready for the soil; and here we may offer an extract from Mr. Hamilton's notes on the subject of soil, and what may be termed subsoil. It was before stated that, according to Mr. Hamilton, "there must be no chamber;" this, it will be seen, saves considerable expense. He uses, however, a good depth of rubble, and thus remarks—"Let the rubble cover the pipes three or four inches, and put three inches below, broken bricks, or boulder stones, &c." And here we may name a matter connected with the height of the building, although somewhat out of place. Mr. H. is for a very flat pitch in the roof, as most good Pine-growers are; the fact being, that in very steep roofs the sunlight is apt to be too intense in extremes of weather, and also that air moisture is much more speedily dissipated beneath such roofs—the steep roof being a more rapid transmitter of vapour in its ascent to the highest level than a flat roof; added to this, it is much more difficult to carry out the interior arrangements necessary for the Pines beneath a steep than a flat roof. Mr. H. wishes to have his Pines almost close to the roof—nearly in contact with it. He says, "The roof ought to be about three feet from the surface of the soil at front, and about four feet six inches at back." Now, any one about to plan, may just draw two perpendiculars at the desired distance, representing front and back walls, and, having adopted the proper slope for a roof, may just count his way downwards, allowing no more depth of walling than is absolutely necessary, and finally throw down a ground line at what height he pleases, which will amount to this, that he can, after planning the necessary depth of walling, build as much, or as little, above the ground level as he chooses. These things, however, are familiar to most persons; and in speaking of soil, Mr. H. says "twenty inches is deep enough." As to the character of the soil, Mr. H. prefers, where attainable, turf from an old pasture; and it will have been observed that he, in another place, speaks of

"fresh turf." If the loam, or turf, is heavy—that is to say, too adhesive, or containing too much of the clayey principle—he recommends using "a little decomposed manure, or leaf mould." In another portion of his notes he observes, "If the old pasture turf is not too retentive, I would use no manure."

Our readers must not imagine from this, that what is commonly termed a strong loam is to be held in abhorrence; but it is difficult to convey a just idea of what constitutes a loam to persons unpractised in gardening matters. THE COTTAGE GARDENER, although notorious for substituting plain English for an ambiguous style, has had, perhaps, more difficulty in rendering the matter of loam familiar to its inexperienced readers, than any other affair, in so small a compass. One thing, however, is evident, that Mr. H. is coveting the organic matter which is so abundant in old pasture soils, and which no compost prepared by hand can possibly imitate. It is not the mere quality alone, it is the mechanical texture that forms its chief feature; and whether it be a matter of capillary attraction, its conducting powers as to heat, or its long-continued permeability to atmospheric action, or whether all these are combined,—certain it is, that for many horticultural purposes we cannot find a substitute for this precious material.

For other remaining cultural matters we must refer the reader to subsequent papers, in the conclusion of which we shall doubtless have some discrepancies to reconcile, some errors to correct; and those interested in this rising taste, fancy, demand—call it what you like—will do well to watch the subject to its close.

R. ERRINGTON.

VISIT TO CLAREMONT.

I INTENDED to visit the great Rose nurseries this autumn, to see the perpetual Roses in bloom, and to hear the gossip of the day about Roses in general, but the weather turning out so wet in September must have spoiled the bloom; therefore I gave them up for the present, and went to see some good public and private gardens, and a few nurseries instead. I have often seen Claremont for the last twenty years, but not so late as this—the end of September—and I never yet left it without a string of fresh ideas. On this occasion, I found them in the midst of great improvements and alterations in the forcing ground, and busily finishing up the housing of half-hardy plants, which they grow to very large sizes, and in the summer they arrange them in pairs, singly, or in groups, in different parts of the flower-garden, and in the pleasure-ground, with the pots plunged quite out of sight in most cases; and this is a style of gardening which is carried out at Claremont better than at any other place that I am acquainted with. Indeed, all the house plants here may be said to be specimens, even to the plants from which they cut sweet-scented leaves and twigs for the nosegays, and the old and fancy Geraniums they force in the spring, for cut flowers, are all in great pots, and the plants look as if they were many years old, from their size, but in their aspect they appear as if their youth was renewed from year to year. By this system, the produce is often doubled from the same space of house or pit room, and with less risk to the plants, and less expense in looking after them.

Some of the specimens in the orchid-house are the largest in this country, and no part of Europe can boast of a pair of larger orchids than the two match plants, *Zygopetalum Mackayi*, here. I know of no place where the *Cactus*, or *Epiphyllum truncatus*, has attained such a size, as in one of the stoves or intermediate stove, grafted here on the, I believe, *Pereskia aculeata*. Here also the *Baumontia grandiflora* flowers as abundantly as at Shrubland Park, or with our correspondent

"Devoniensis." The *Euphorbia jacquiniiflora* is also very large, some of the young shoots being from three to five feet long, and when in full bloom, what a splendid wreath the tops of two of the shoots would make, placed in this fashion—one from behind each ear, with the points or tops meeting in the centre of the forehead, and then passing each other about two inches or rather more; to these add four more tops, same size as the first two, and form the six into a star, and my word for it, you would conquer the French President himself, in one night, as sure as ever his uncle was overcome at Waterloo.

But, instead of attending to ball-rooms, we are to see how they are going to provide more room for their greenhouse specimens at Claremont. The old, long house in the forcing ground, once called the "the succulent house," and afterwards the "greenhouse," is no more, and on its site is placed a specimen house, hard upon a hundred feet long, and fourteen feet wide; a broad walk down the middle, to enable them to pass up and down with huge bushes in pots, &c., and a stage on each side, much better than a slate stage, and quite as durable, and drained on the same principle as a garden-pot; thus, a succession of brick arches run along each side, with facings or kirbs next the walk, and a little higher than the crown of the arches. Now, the spaces between the arches are filled up, first with brickbats, then with rough cinders, and a finishing coat of finely-sifted coal-ashes, the whole on both sides being quite flat and level. Provision is made for letting off the drainage from between the arches into a drain. With this kind of stage the house can be kept very dry in winter, and as wet in summer as they choose to make it, without wetting the walk at all; and see what room there is for stowage under the arches. The house is to be heated with hot water, and the same boiler will heat it, and ranges of pine and other pits close by. When the whole is finished, and well proved, I shall ask for the drawings, and some of the specifications, for our pages. All the Pines are grown and fruited here in pits, and they fruit them very extensively every year; the plants look remarkably stout and healthy, with short, thick, and broad leaves—always a sure sign of well-to-do; yet Mr. Malleon says the French beat us out-and-out in the culture of the *Pine*, and that they get one-fourth more weight of fruit from a given space than we do. He was in France this summer, and saw fine Pines fruiting in No. 32 pots. He told me, also, that there is as great demand there for British gardeners now, as was in England once for Scotch gardeners, but for want of a knowledge of keeping accounts in the French way, and not knowing even the rudiments of the French tongue, our young men are not qualified for the Continent. The *Grapes* have also been equally fine this season, chiefly Black Hamburgs, and Canon Hall Muscats. Some of the bunches were a foot long, and the berries particularly large and well flavoured. The vines are pruned on the spur-system, and as soon as the leaves drop off in the autumn.

The Cornelian Cherry-tree (*Cornus mascula variegata*) was in ripe fruit, trained horizontally against a south wall. I never saw this plant so treated before, nor with ripe fruit on it; the fruit is very handsome, and good to eat; it is blunt at both ends, about the size of a small plum or sloe, and of a rich deep claret colour. This kind of Cornel is, therefore, a fit subject for a conservatory-wall, where no glass or artificial heat is used; and to get rid of the kitchen-garden idea, the plant should not be trained horizontally like a pear, but in the fan manner. The flowers of *Cornus mas*, as some people call it, are of no account—yellow little starry things in clusters, but they come very early in the spring before the leaf.

In another part of this garden there is an old plant

that is hardly known among gardeners, yet it is an excellent one for a small garden; it is ten feet high, and looks just as if it was a cross seedling between an ash and a walnut, and the fruit is like a walnut, but is winged. Where the *Ailanthus glandulosa* would be too large this would be a good substitute. The name is *Pterocarpa Caucasica*.

Most of the species and varieties of *Conifers* have been planted here, but the new ones are not yet of a size to attract much attention. *Deodars* twelve feet high; *Cryptomeria japonica* ten feet, and as much in diameter at the bottom; *Pinus insignis* about ten feet; fine plants of *Cunninghamia lanceolata* from twelve to fourteen feet; *Cupressus macrocarpa* eight to ten feet, and, being seedlings, grow up as straight as the Lombardy poplar; very fine examples of *Cupressus torulosa* from ten to fourteen feet.

A large plant of *Wistaria* covers 130 feet of a wall ten feet high, and one of *Chinanthus grandiflorus* eighteen feet of the same wall, and seeds freely every year; and as this is one of the most difficult of our hardy plants to increase by layers, this seed ought to be looked after wherever they ripen, as every garden, however small, ought to have one for supplying its deliciously scented flowers during the winter.

The moment I entered the garden I noticed a new flower-bed a good way off, but of what flowers it was made up, D. Beaton could not tell on the instant. It was a lucky hit by Mr. Malleon, and one that any planter can imitate, and much easier than the shot-silk bed, of which I have not seen a single instance this season that was not a complete failure. This new bed was made with the old rose-scented *Geranium* (*Pelargonium graveolens*), mixed with the *Verbena*, *Robinson's Defiance*. It was a large circle, and the *Geranium* was quite thick all over the space; and very likely few other *Verbenas* could stand so much smothering, for I could hardly see a leaf of the *Defiance*, but the bloom was as regular and thick as if there was no *Geranium* in the bed, and well up above the leaves, making the deception complete a short way off. Mr. Malleon told me that the *Beauty Supreme Verbena*—a pinkish variety, as strong as *Defiance*, or nearly so—planted in the same way with *Mangles' Variegated Geranium*, is equally effective; but these variegated *Geraniums*, and all the more delicate sorts, were potted and housed before I called. It happens very luckily, that every one who is fond of plants likes these two *Geraniums*—the one for the scented leaves, and the other as the best of all the old variegated *Geraniums*. Instead, therefore, of planting out the Rose-scented *Geraniums*, as at present, in all sorts of out-of-the-way places, merely to keep it going, or about the doors, to be rubbed and sniffed at on your going in or out; a bed may be made of it, or a large basket may be legally filled with it on the open lawn; and the scarlet *Verbena* will look more showy over the dark green and jagged leaves of the Rose-scented than in the more natural way, without the help of the *Geranium*. Now, I would advise, at once, a diligent search to be made for all the Rose-scented *Geraniums* that were planted out this season, so as to come in for a bed next year; we shall want plants, at any rate, for 20,000 or 25,000 of it next May, and therefore we cannot afford to lose the old plants; besides, it is ten to one if young plants struck next spring will answer so well as old ones, because the soil at Claremont is so favourable to the growth of this tribe, that they come to an enormous size by the autumn, and yet this last bed did not appear to be a leaf too strong at the very end of September. The plants, in another large bed, of *Diadematum rubescens*, a very moderate grower, were, on an average, two feet high, and some of them double that in diameter. I never saw such a sight before. I never could get it to grow above a foot at Shrubland; and at Kew, this

season, it did not even cover the ground at the beginning of October, although it was planted as thick as usual.

I saw another contrivance, a new move, which looked remarkably gay—a row of Black-eyed Susans, or *Thunbergia alata*, seventy-two feet long, from four to five feet high, and a yard through at the bottom, right out in the open air in front of some hothouses, but they were planted about four feet from the wall, and were staked just like so many Sweet Peas. They all looked as healthy and as full of flowers and seeds as ever any Sweet Peas did. There were three kinds of them mixed; but the white one—the real Black-eyed Susan of our impy days—looked the best. The wonder is that they escaped the red spider at the beginning of July, for naturally they grow much in the shade; and in-doors they do better trained up a dark, damp, back wall than full in the sun. To try this experiment, get a shilling's worth of mixed seeds; sow them in any light, rich soil, quite thick, about the middle of March, or, at least, before the month is out; place the pots in a brisk cucumber bed; and when the seedlings are two inches high, top them by nipping off the very points; and as soon as fresh shoots come out they are fit for potting, when they ought to have very rich, light soil, and to be put three in a pot of three inches over, unless the crop is scanty, when one plant will be enough for a pot. Never allow them to get above six inches high while they are in heat; that is the grand secret; as, when the pots are quite full of roots, and are put into cold frames by the end of April, they will make a strong push all from the bottom, and the foundation is then laid without forcing them. By the third week in May, they will stand the open air all day, and the light to be drawn over them in cold nights. As soon as the weather is mild and settled in June, plant them out in the very richest compost you can make with very rotten dung, leaf mould, fresh turfy loam, and a kindly aspect, and allow them abundance of water as soon as they take to the soil. Any one who can grow celery will find no difficulty with these, only they must not be planted in trenches; but if a space like a celery trench was prepared for them, then filled in with good stuff, and the balls planted entire on the top, you would have them as good as they were at Claremont with half that trouble.

In the centre of the garden were four beds of mixed *Portulaccas*, and each bed would need some hundreds of plants; they must have been most gorgeous earlier in the season, for even now, after a month's rain, they were not amiss, and there was not a blank in any of the beds. Mr. Malleon told me that in some parts of France they grow them by the thousand, and they do so well, that one can hardly look at them in the middle of the day; and, in the same gardens, the *Plumbago Larpente* is one mass of light blue all through the autumn, and the best mass plant they had from us for years.

A double crop of flowers is got here from that beautiful, dark, purplish-blue *Delphinium*, or Larkspur, called *Barlowii*, by cutting the whole plant down to the ground as soon as the flowers begin to fade in June, and, after awhile, giving some good soakings of water to the bed. The second bloom was in its prime when I called. A very large bed in one part of the garden is every year full of *Hydrangeas* in bloom, as regularly as a bed of tulips; the plants being treated as biennials struck from cuttings, and planted out to nurse the first year, and in this flower-bed the year following.

I knew, for many years, that the *Amaryllis belladonna* was better managed at Claremont than elsewhere, and I made a point of asking about it particularly on this occasion, and I found a whole row of it in front of a long row of hothouses in full bloom, and every root or

bulb in the row appeared to be exactly of the same strength, for, out of the whole, there was not a single stem an inch above or below the average height; they all stood as upright and regular as a regiment in single file, which I took to be a high compliment to the royal owner—His Majesty the King of the Belgians, to whom Dr. Herbert dedicated his large work on the Amaryllids. Mr. Malleson takes up all the roots every sixth year, in the month of June, divides them, and, after renewing the border with fresh earth, replants them in single line, placing the bulbs six inches below the surface, and nine inches apart, and about fourteen inches from the wall; behind them, and within three inches of the wall, he has a full row of mixed *Lias*s now in leaf, three inches high, and none of them receive any protection whatever, save what the leaves of the Belladonna afford. These *Lias*s are also allowed to increase and multiply for six years, then are taken up, divided, and the strongest roots put in again three inches deep, and they do as well as Crocuses. There was not a single gap or failure in either of the rows. Patches of both kinds are left in another border to take their chance, without being ever disturbed, as a lesson for the young gardeners to see the necessity of a regular course of culture for bulbs that would seem to most people to do well enough without any care whatever. There were other evidences in this garden of a desire to "teach the young ideas how to shoot," in cases where the requirements of the establishment did not seem to want such things.

I also saw a new plan for getting nice young flowering plants of the new *Jasminum multiflorum* for winter-flowering in small pots. This flowers in winter on the young wood made during the previous summer, and stools of it are planted out on a rich border, from which long shoots rise every year, and when the growth is nearly finished they are layered in small pots, where they soon root, and are then fit for the purpose required.

D. BEATON.

SHOWING OFF PLANTS IN ROOMS.

GROWING PLANTS IN ZINC VESSELS.

AFTER the article on floral boudoirs, to which myself and readers are indebted to the inquiries of a correspondent, some complaints have reached me, that I and others would throw cold water over the attempt to grow plants in windows and rooms, and thus deprive many of one of the sweetest pleasures that it is possible to realize. Sorry should I be that such an effect should be for a moment felt. The conservatory boudoir attached to the mansion would yield an amount of refined interest which plants in living rooms can but rarely evolve; still, the advantages of a floral boudoir may, in some measure, be realized, even in living rooms, by concentrating in one particular part all that is blooming and lovely—a measure which it is often needful and advisable to adopt, when, owing to peculiar circumstances, the proprietors will have their showy plants brought for short periods to the house to inspect them there, even though the idea should be felt, that the plants and their accompaniments are not quite in character with the elegant furniture surrounding them. To counteract this impression, I have recommended ornamental artistic pots for such situations, showing, from experience, with iron, porcelain, and china, as well as with common earthenware, burnt hard, or painted on the outside, that the popular trade error in favour of soft greasy pots was rather more than a delusion. In addition to this, it was recommended that, instead of having numbers of ornamental pots of a miniature character scattered about, it would be better to use common small pots for growing, and then to concentrate a number of these into orna-

mental vases or boxes, covered over the surface with green moss, and with a contrivance below to receive all the extra waterings, which otherwise might find its way into the room. In the case of an elegant box or basket, lined with zinc inside, this receptacle for water may be supplied in the shape of a drawer, waterproof, near the base line of the box. In vases, the lower pedestal should open for a similar purpose. It is an easy matter to make such a pedestal of wood, and with paint and sand it is as easy to make it resemble the vase, however ornamental.

Still, after all this was done, either in our own case, or that of our friends, there seemed to be something wanting to make up a sum total of agreeableness. If the flowers stood near the window, the want of a reflecting back-ground was at once felt. If they were placed farther in the room—at its centre, or near its side—not only was the want of a suitable natural back-ground felt, but the colour of the paint or papering of the room often made the plants look inferiorly different from what they did in their more appropriate homes. Now, the remedy for this would seem to be almost intuitive; very simple, indeed, when once named; and some of our clever contemporaries may have adopted various modes for counteracting the deficiency; but I confess I have seen or heard of no method so simple, and so likely to prove effective, as that practiced by Mr. Fleming, at Trentham—a place which every one fond of, or engaged in gardening, should, if possible, visit, whether his superintendance extends to a few yards or an expanse of acres; whether his views are mostly bounded by his window plants, or his mind rather delights to revel among the vexed questions of building, heating, glass-walling, &c., so characteristic of the day.

Well, in going round, close to the mansion we came on some elegant boxes, seemingly of mahogany or stained wood, with a trellis formed of rods of similar wood, fixed to one side, say the *back* of the box. The box itself was divided into three compartments—two small ones, one at each end, and a larger in the middle—each furnished with separate vessels, shaped like the box, and thus easily set in and removed at pleasure. In the two smaller compartments, at the ends, *Ivy* was planted, and trained over the trellis, thus furnishing a beautiful back-ground. The largest centre division was reserved for flowering-plants, turned out of pots, or grown as hereafter to be mentioned. I forget the *size* of the boxes, say somewhere from three to four feet long, from one to one-and-a-quarter wide, and from nine to twelve inches deep, and the trellis from three to four feet in height, to be tall enough just to reflect the beauty in rooms of such gorgeous plants in winter as *Poinsettia pulcherrima*, *Euphorbia Jacquiniflora*, &c., of which there seemed to be great abundance of fine, young, healthy plants. The size of the boxes is of less importance, as our amateur friends, when once they take the matter up, will vary the size of the boxes, and the height of the trellis, according to the plants they wish to show off. One box might thus have several trellises ready to put off and on at pleasure; and even the vegetation on the trellis might be changed, to suit the size and colour of the flowers, by keeping plants growing and trained in pots, or, better still, in vessels suited to the destined compartment. If well managed and trained previously, there would be little difficulty in fixing them to the ornamental trellis. My mind instantly reverted to many plants as suitable for this purpose, such as the *Vinca major* (the Periwinkle) for large plants, and the *Vinca minor*, in its various forms of green, white-variegated, and silver-variegated, for low-flowering plants. So far as I recollect, Mr. Fleming seemed to have used the *Ivy* exclusively, and that he had found it to stand room-treatment well, with the advantage he gave it of not exposing it too much when first bringing the boxes

out, and then giving them a good breathing-time out-of-doors.

But, as bearing not merely on this subject, but on ornamental pot-gardening, however used, Mr. Fleming mentioned a fact which is well worthy of being more generally tested—namely, that he found plants to flourish better in *zinc vessels* than in any other he had tried. He considered that, from the conjunction of the earth, water, and air, with the zinc, a galvanic action was promoted, in which the plants delighted. Now, I had frequently sown all manner of seeds, and inserted nearly all kinds of half-hardy cuttings into worn-out zinc evaporating pans, flat, and also with round bottoms, and though the things did well enough, I never noticed anything particular about them—in fact, I never made any note on the subject at all. As “seeing is believing,” Mr. Fleming took us to see plants so growing; among others, he pointed out oblong boxes, with two or three Poinsettias growing in them, just of the size to fit into the ornamental boxes, with attached trellis above referred to; and certainly, in contrasting them with their neighbours in pots—and those in pots enjoying individually rather more room and soil, and every other circumstance in common—if there was a shade of difference where all were healthy, the zinc-potted plants had a deeper, blacker green in the foliage. Now, the above fact is one that many a man might have got gold by in the ancient days of exclusiveness. Whatever may be made of it by the trade, and we sober-sided, stand-still practicals, as our more theoretical-progression friends at times call us, it opens up a fine idea for the amateur of refined and artistic tastes. I cannot say how long zinc will last when used for such purposes, as certain waters are apt to corrode it; but, at any rate, it is not so liable to injury as either pots or china vases; it is light, thin, easily moved therefore, and easily inserted inside of other vessels, and requires but little ingenuity in the workman to bend and twist it into all manner of classic and artistic shapes; and as it is cheap, and may be coloured at will, it may thus be instrumental, either as smaller or larger-sized vessels, for banishing the red earth pots from the windows of our cottage *orneés*. In opposition to the maxim, that “prices rise with the demand,” I believe, in this and many other instances, that prices would be moderate in proportion to the numbers of the article wanted. A beginning here may soon lead to greater improvements in our utensils for plant culture.

R. FISH.

TALL LOBELIAS.

(Concluded from page 45.)

In my last paper on these plants I described the mode of raising them by seed. The next head is raising them *by slips or cuttings*, and it is a fortunate circumstance that they are easy to propagate that way, so that any one possessing two or three plants may soon have quite a stock.

The time for this operation is in autumn, just before the plants go out of flower. Frequently they will produce on the flower-stems short leafy shoots—these make the very best cuttings. Also the flower-stem itself may be cut into short lengths, that is, with two buds or joints. The lower joint should have the leaf cut off, and the upper one should have the leaf belonging to it preserved. The pots for these cuttings should be well drained, and filled with rich light soil, well pressed down, with a thin covering of fine silver-sand on the surface. Whilst the cuttings are being gathered and made, give the pots so filled a gentle watering, which will settle the sand, and make it firm by the time the cuttings are ready. With a smooth stick, about as thick as a good quill, plant the cuttings round the pots close to

the edge, turning the leaves so that they may point inwards; they may then be set closer together without interfering with each other. Press the cuttings firmly to the pot side, and fill up the holes with a little more sand, then give a gentle watering, and place them in a gentle heat, or, where there is such a convenience, in a regular propagating house. They will root in a shady part of a greenhouse, but not so certainly or quickly. As soon as they form roots they should be potted off into three-inch pots, and be allowed to remain in heat for a fortnight or three weeks; then place them near the glass in the greenhouse, till they have filled the pots with roots, when they may be allowed to go to rest, but should be kept just moist enough to prevent them losing their roots through the winter. If well managed, about the month of March they will begin to grow again, and will form fine plants for flowering that year.

By Division.—Where room is scarce, and the kinds plentiful, this mode of increase is the least trouble. As soon as they have done flowering, cut down the flower-stems and take up out of the bed or border a number of plants; reduce the ball of earth, and pot them into as small pots as the plants can be got into without crushing. Place them either in a greenhouse or a cold frame, well protected from frost; give water about once a month in case they should be very dry, or if they have been grown in pots, as soon as the bloom is over, cut down the flower-stems, and place them in the same situation through winter. When the warm days of spring arrive; several shoots will be seen springing round the centre of the plants. As soon as that is perceived they may be divided at once. Take a pot in that condition, turn the plants out of it, and shake a large portion of the soil away; then with a sharp knife divide the shoots from each other, preserving some roots to each division, and one or two young shoots; pot them into as small pots as they can be got into without crowding the roots. Place them near the front glass of a good greenhouse, or in a frame kept close and warm till the plants begin to grow, then give plenty of air, and a fresh potting as soon as they have filled the pots with roots.

This is the conclusion of my remarks on propagating these fine flowers. I find I have incidentally included under this head that of *wintering the plants*, and in consequence need not repeat it, but commence now with

The Soil.—To grow these plants well in pot is an important point in culture. When *Lobelia fulgens* was first introduced, a very clever gardener, now no more, a Mr. Hedges, gardener to the Earl of Mansfield, at Caen Wood, was very successful in growing and blooming them. The soil in which he cultivated them was a very rich one, consisting of loam, peat, and well-rotted cow dung. This grew the plants very strong with plenty of foliage, but not so much bloom as we require now-a-days. The soil that I have found to answer best is turfy-loam, peat, and leaf mould, in equal parts. This gives a sufficiently strong growth, and the plants flower more abundantly. To sustain and bring out the bloom, I give, as soon as the flower-stems have decidedly appeared, a weak solution of manure-water every third time they require moisture.

General management and preparing for Exhibition.—The general management consists in re-potting several times during the earlier months of the year. This causes the plants to continue growing strong for the time, and enables them to throw up several strong flowering-stems to each.

Watering.—The Lobelia is a water-loving plant, and therefore, to grow it well water should be given liberally. When the plants have received their last shift into the blooming-pots, nine inches in diameter, and these pots are filled with roots, it will be found advisable to place pans under each pot, to catch the water that passes through the pots, but it must be allowed to dry up sometimes.

The place to grow them should either be a deep pit or on the stage of a greenhouse. To prevent accidents, it is desirable to place a small stick, painted green, to each flower-stem, tying them rather slackly with soft matting. These sticks may remain till the plants arrive at the place of exhibition, when they should all be removed, excepting the centre one. The stems should be strong enough to keep their position. Each stem should bear a long spike of flowers, seven or eight of which should be in bloom at the time; each bloom should consist of petals that are broad and highly-coloured, whether the colour is scarlet, purple, or blue. The best number, or at least a sufficient number for a stand, will be six. That number will include all the best varieties at present known, but if a greater variety is raised, the number may be raised.

Lastly, *Hybridizing*, in order to improve the varieties. This is done in the usual way, that is, by cutting away all the anthers from one flower before the pollen cases burst, and applying the pollen from some other variety, possessing qualities desirable to add to those possessed by the one to bear seed. The flowers thus hybridized should be protected from bees and other insects by a covering of fine net muslin. T. APPELEY.

JOTTINGS BY THE WAY.

(Continued from page 44.)

In the course of my journey I visited the ancient town of *Coventry*, famous for the somewhat apocryphal history of the Lady Godiva and Peeping Tom. There happened to be an *Exhibition of Plants, Fruits, and Vegetables* that day, and I was much gratified to see so many good things on the tables. The gardener at Lord Leigh's, of Stoneleigh Abbey, had good well-bloomed plants of *Allamanda cathartica*, *Stephanotis florabunda*, *Pleroma elegans*, and others. The fruit was also respectable, and the vegetables excellent. It is delightful to observe, at country exhibitions, the very excellent vegetables produced by cottagers: it was especially so to myself, having been so long connected with a work partly devoted to their instruction; and I do not know a more acceptable and useful present to an industrious, hard-working cottager than the first two volumes of THE COTTAGE GARDENER.

On the same day, I had a great treat in visiting the gardens at *Keursley House*, three miles from Coventry, belonging to the Rev. Mr. Thickers. Mr. Craddock is the gardener. There I saw a noble specimen of that beautiful fir the *Picea Welbiana*, a handsome tree with all the branches symmetrically arranged, and not one in the least injured by frost. I may venture to say this is the finest specimen in England. It was full sixteen feet high, and ten feet through. It is planted on the lawn in front of the house, which stands on a considerable elevation. The garden is sheltered on the north and west sides. The subsoil is a kind of shaly rock, with a thick coating of good loam upon it. These circumstances, no doubt, were favourable to the growth of such Coniferæ as are rather tender, like the one I am describing. There was also a thriving specimen of that fine tree the *Abies Douglassii*, twenty feet high and twelve feet through. This specimen was also perfect;—not a branch was wanting to destroy its symmetry. *Abies Menziesii* had reached twenty feet high and ten feet through. The lowest tier of branches reached to the ground, and were regularly disposed up to the last produced tier, forming a truly unique, handsome specimen. *Cupressus macrocarpa*, or *Lambertiana*, was twelve feet high, and a fine, well-clothed-with-branches specimen. There were also thriving trees of *Cryptomeria japonica*, *Cedrus Deodara*, eighteen feet high; *Araucaria imbricata*, and a very green tree of *Araucaria Cunninghamii*, perfectly healthy;

besides many others, more common and of less note, belonging to this tribe. In another part of the grounds I observed a good healthy tree of *Benthamia fragifera*. I was informed that this tree had not as yet fruited. On the rock-work, which is rather extensive, there was a good collection of British Ferns; and in the garden where the glass-houses are, I observed good plants of Heaths and New Holland plants. The place altogether is not very extensive, but is kept in excellent order throughout. I am sure any lover of rare and beautiful, healthy, Coniferæ, as well as other plants, would be as much pleased as I was to view so many unique specimens in so small a place. It is a beautiful drive from Coventry, which is the nearest point by railway to it.

The neighbourhood of Coventry abounds with gentlemen's seats, which are well worthy of spending two or three days in seeing them, especially *Stoneleigh Abbey*, about four miles from Coventry. This place, with respect to gardening, is undergoing considerable alteration. Mr. Nesfield has laid out, in his peculiar style, a new terrace garden, and a large new conservatory is just finished, but not filled with plants, at least it was not when I was there. The present owner seems to be a very kindly-hearted man. The day I visited the place he had a large number of poor children at the hall, and was giving them a feast. Never did I see a happier or merrier group of children; the lord and lady were quite as happy, and as harmlessly merry as the young urchins they were entertaining. It was, we understood, the second birth-day of the young heir that occasioned the holiday. It is such kindness that endears our aristocracy to their dependants. May such kind-hearted nobles increase to render the poor happy and contented.

The kitchen gardens are extensive, and also improving. In one new house I noted a large number of vines in pots to be fruited therein; they were almost as strong as those on the rafters; the wood was ripening beautifully, and they will, no doubt, bear a plentiful crop next year. A span-roofed lofty vinery had been at one end replanted, and the vines were growing strongly. This kind of vinery is rather common, but I know none that shows off the vine so beautifully.

On the road to Stoneleigh Abbey is *Styvechale Hall*, the seat of G. Gregory, Esq. The gardens here are improving much under the fostering care of Mr. John Ashton; and a little distance off is *Whitley Abbey*, belonging to the Hon. Mrs. Hood. This is a very ancient place. I was much pleased with the rock-work here, which is not artificial; the natural rock has been bared to a great extent, and planted with deep rock shrubs and herbaceous plants, and is the most unique thing of the kind I have seen. T. APPELEY

(To be continued.)

WINTERING CAULIFLOWER PLANTS.

It is generally admitted that the production of early Cauliflowers, in conjunction with that of Peas, forms the line of demarcation between the winter and the summer products, which in each the garden may be expected to furnish; and it seldom happens that the Cauliflower, under ordinary circumstances, can be brought into bearing immediately the last Brocoli of the season goes out, an interval of a few days (certainly not more than a week) occurs before this important vegetable takes its place. Now, though it is well known that Brocoli (or Cauliflower either) will keep a few days hung up in a cool place, if not too much stripped of leaves, yet it is always advisable to arrange the planting and other conditions, so that the succession may be such as to dispense with the "preservation system" as much as possible, more especially so at a period when vegetation is so much on the alert as to act in an inverse ratio with

the keeping qualities of the article in question; now, in order to have Cauliflowers as early in the summer as possible, means must be taken to forward their growth in such a manner as to ensure their arriving at maturity in the shortest possible time, as in the case of many other things, the attempt to accomplish this sometimes leads to an opposite extreme. The rearing of plants too early in autumn causes them to attain a sort of matured growth sooner than they ought to do, and the consequence is, they present us with their premature heads long before they have attained that size which is requisite for their usefulness. This is what is called "buttoning," and is just exactly what the skilful cultivator tries to avoid. Now, though we have occasionally had such mishaps, and every one who tries to have his produce early must expect some of the plants to run thus prematurely to head, yet the fewer of such useless productions the better, and the only way to prevent its happening, is not to sow too soon, while to delay that duty too long is attended with risks from another quarter;—the young plants, unable to stand the rigour of winter, either perish, or if they live, cannot possibly come in early; but as all this has been explained, I will suppose that a seed-bed, well furnished with robust plants, is just waiting to be planted out.

A well sheltered border facing the full south, but defended on all other sides, should be dug and manured, adding as much mortar-rubbish as can be had, to expel the slugs and other enemies that may be lurking there. This ground must then be measured off in such a way as to give space for the tops of the hand-lights being taken off, and still afford room to walk through and examine them as required. The common sized square hand-light will hold nine plants, which, after planting, may be covered up a few days to assist them in forming roots, and otherwise establishing themselves; after which they may be gradually uncovered, so as finally to inure them to the cold air, when the thermometer is not too much below the freezing point. A mild, dull season, encouraging an unhealthy growth, is at variance with the plant's preservation when severe weather does set in: fortunately it often happens that very sharp frosts are preceded by more or less of cold chilly weather, which hardens the plant so that it endures the frost with less injury than if a severe frost suddenly followed an open mild season.

Though there are various modes of obtaining early Cauliflowers, this old-fashioned one may still be regarded as the best; but another way is to have a quantity of plants potted, which being partly protected and partly forced, are planted out in March, on some well-prepared situation, as under a south wall; yet it does not always happen that such are the earliest after all, and when the extra trouble is taken into account, the odds lie certainly on the side of planting under hand-lights; or, if they be wanting, a common frame may be placed in such a situation, and filled with plants, which, being treated exactly the same as the above, may be thinned in spring, and the residue left to grow where standing.

It very often happens that both frames and hand-lights are required to protect the necessary number of plants that are wanted in spring; and, in fact, if frames be not wanted for anything else, it is better to appropriate them to this purpose than allow them to remain idle. Now, in addition to the above modes, many temporary ones are made use of with equal success. A bed is made and surrounded with rough slabs, sticks are hooped over it, and a few longitudinal ones being added, mats or other covering are thrown on in hard weather: and with this purpose in view the size and shape of the bed is made in accordance with its covering. In a mild winter, and in the south of England, they will but seldom want covering up; but, in more bleak districts, this will be more wanted: in the latter case, a greater

breadth ought to be planted under glass, if possible; and, in very severe weather, that will be the better for a little covering up, if snow does not affect that purpose.

In the general management of plants in positions as above, it is to be understood that a robust growth is to be encouraged, rather than a delicate, tender one. A little frost ought never to hurt them, which it assuredly would, were they nursed in a temperature more suited for geraniums; in the latter case, the elongated leaves, and the general development of the plant at a period at variance with the state of things out-of-doors, renders it very unfit to withstand any amount of hardship. Nothing is better to harden this, or any other description of half-hardy plant, than the cold drying winds we sometimes have in autumn and winter; the chilling effects of this suspends all growth that may be active, and by contracting or sealing-up those pores, which, in a more excited state, rendered the plant liable "to catch cold," by every cold draught, inures it to that condition in which its constitutional hardihood is put to a fair, yet not severe, test. When hard weather really does set in, it is better to open the frames or hand-lights a little, to allow the damp atmosphere to evaporate. Let us suppose a clear sunny afternoon in December, or January, which we know often betokens a sharp frost; on such an occasion, let the plants be very much exposed, and when shut in, both they and the ground they occupy will be less charged with moisture than previously; and if even a little crispy stiffness from frost has caught hold of them, they are no worse, providing they have been properly inured to cold previously; with this care they may be covered up for several days, if a succession of severe weather forbids their being opened; as by being partly chilled, or shall we say "benumbed"? the active powers of vegetation, as well as of decay, are very much checked: the latter being hardly less important than the former. Care, of course, must be taken in re-opening them to the currents of cold air, but the dull weather that usually follows the "breaking up of a storm" facilitates that; everything being done in the mean time to gradually accustom them again to full exposure. By attending to these simple rules, the amateur will be able to carry his plants through the winter with that degree of robust health which is the only safeguard to a successful issue.

J ROBSON.

ALLOTMENT FARMING.—NOVEMBER.

At last we are arrived at that part of the year when the vegetable kingdom, for the most part, sinks into a state of repose—a not less wondrous provision of Almighty God than that cheering activity and exuberance exhibited in the garden and the field during the spring and summer. By this annual repose, the exhausted soil is enabled to lay in a store of the necessary gases, or qualities derived from the atmosphere; a great proportion of the insect tribes, which otherwise would accumulate in a most destructive degree, are destroyed; and, in addition, the earnest cultivator is enabled to carry out improvements connected with the staple of the soil without loss of time in regard of cropping. To the latter point we would direct especial attention. We never saw a plot of ground yet but that something might be done for it still in the dormant season—something to increase its value and efficiency; and as long as we have the pleasure of conducting out-door operations of this kind, we shall aim at no lower a standard than annually making the land worth more than it was in the preceding year. This may seem a bold standard to assume, but we are persuaded that in the majority of cases it is attainable.

Amongst the most solid and lasting improvements, draining may be pointed to; without this, all other appliances are but a waste of property. By it, where soils are sour, both organic and inorganic matters are brought into play that would otherwise remain inactive; the cultivator is

enabled to deepen his soil—a most important matter at all times, as affording continuous nourishment to the roots of crops during protracted droughts; and, in addition, the labourer is enabled to work his soil with half the trouble.

But one of the most important features connected with draining remains to be pointed to—we mean the increase of ground warmth. Our labouring friends, who are more familiar with the spade than the pen, may think this a trifle, and may stare when we tell them, that not only the gardeners' pine-apples and cucumbers require a bottom-heat, but that it is beneficial in a high degree to most of our ordinary crops. To say that a given plot of ground, five degrees of warmth in advance of an adjoining plot of equal extent and quality, will produce earlier vegetables, is to affirm what needs little consideration; but we go a step farther, and affirm that it will produce more abundantly. Providence has so ordained it, that the ground heat over most of the habitable parts of the globe is some two or three degrees higher than the air heat, taking the averages; so that means taken to increase the ground warmth are not so artificial a proceeding as would at first sight appear.

Next to draining, we regard the improvement of the staple the most important matter, and one, of necessity, facilitated by the former. However, we would not rest content with that amelioration which proceeds as a mere consequence, but carry matters farther. It only requires to appropriate a little of the beer-shop money and time to such matters; not that we suppose, by any means, that many of our readers in humble life are in the habit of thus squandering their time, although we do know that such characters are to be found in all countries; long may they form the exception.

We have not space here to go into details of advice concerning "staple improvements," but may merely point to the fact, that lime-rubbish, and cinder-ashes, burnt moor soil, and such like, are well-known improvers of the staple of clays; and that marls, burnt clay, ditch or pond scourings, peaty soils, &c., are of much benefit to burning sands; and lime, strange to say, has been found to benefit both.

We must now proceed to examine the position of the allotment or cottage garden, and its crops, stores, &c. And first,

POTATOES.—This has been a grievous year as to this invaluable root; great have been the complaints, and, we are sorry to say, great the losses. Nevertheless, so great is the breadth planted, that we are assured the country will be pretty well supplied after all. It appears that the potato has, in these days, a double ordeal to undergo; the first, when the "plague spot" first overruns the whole system of the plant, quite perverting its juices; the other, when the tubers are removed, and, as is too much the case, permitted to ferment, by being placed in a considerable body. These are crises in the character of the potato of latter days which deserve a little study. As to the former, all seem alike at fault; a cure is out of the question; preventives are the chief consideration. No man in his senses can doubt—however much or little it can be made to bear on the disease question—that well-preserved seed must lead to better results, in some form, than neglected or abused seed. We will at once take this for granted, and then the question is: how to preserve seed well? Common sense teaches the veriest clown, that when a potato has sprouted, part of the virtue or energy is exhausted; and that in a state of nature this process takes place in the soil; the conditions almost diametrically opposite. The former, or artificial, condition of the tuber being one exposed, perhaps, to a high amount of perspiration or fermentation, and to a capricious medium; the latter to darkness, and a sort of quiescent state. We merely throw out these observations to set our allotment-men thinking during the long winter evenings; and we advise them to persevere, and not doubt but that the potato will one day be restored to them in its original purity, however long the ordeal may be through which it has to pass.

STORE-ROOTS.—We come here to the general principles of store-root preservation, which are few indeed, and exceedingly simple. These are the points—

- Dryness.
- Exclusion of air.
- Absence of fermentation.
- A low temperature.

As to the first, they can hardly be too dry, if the dryness is accompanied by a very low temperature; if we could select or lay down a pitch, we should say 35° to 40°. Exclusion of air is but another term for darkness, which is, indeed, an essential; and, in general, what promotes the one accomplishes the other. Exclusion from the air prevents loss by perspiration; and darkness prevents a tax on the growing tendencies of the crowns of such roots as Mangold, the Swede, Potatoes, Carrots, Parsnips, &c. Fermentation, caused by placing roots in too great heaps, robs them of a considerable amount of both their nutritious and keeping properties: this is the very bane of many proceedings. A low temperature is another important affair. *Rest is the maxim* with all these things; to this end northern aspects must be sought, and other local advantages, taking care that a high and dry situation be selected. No lodgment of waters must ever be thought of where roots are stored. Thus much about roots in the lump; we have not space for detail. We may, however, observe, that it is well with all store-roots to cut the crown somewhat "into the quick;" the growing principle is thereby crippled for a longer period, and, indeed, weakened. Mangold should be immediately got in, the roots scraped with a piece of stick cut to an edge, and housed dry, if possible; if there is no room in any outhouse, they may be piled, in a dry state, on a piece of high and dry ground, and simply covered nine inches with soil, taking care to sharpen the exterior to a ridge, to throw off rains. Swedes may remain on the ground for another month, for they are very hardy; and, as the Mangold tops are now in use for the pig, &c., the Swede tops may thus be made to succeed them. Parsnips may remain where grown all the winter, unless needed off-hand. Our practice for many years has been to trim off the leaves in the early part of November, and immediately to manure the ground for the succeeding crop; then to open a trench a good depth at one end of the row, and thus provide for trenching them out as wanted, at the same time ridging the soil ready for the succeeding crop. Land, thus treated, is in fine order the following March for any crop of importance. Carrots will, of course, be stored, as they are tender; we cut their tops completely to the quick—a plan named twenty years since in Loudon's Magazine, and which we have practised ever since; it assuredly keeps the roots fresh much longer, and no injury has ever arisen from the practice.

CABBAGE-WORTS.—We long since explained that this broad term was intended to express all those greens, whether Cabbage or not, which are in these days worked into the general cropping economy—some preferring one kind, some another. If we were in a position to grant allotment land to the industrious, we should assuredly take all the lawful means in our power to persuade or to coax our tenantry to secure a sprinkling of these over all portions of the land occupied by summer crops. We are led to these remarks by observing, in a late northern trip, some of the finest soil "that ever a crow flew over," as our Cheshire peasants have it, lying totally idle for the winter, after a crop of rotten potatoes, and this, too, land bringing some three to five pounds per acre. This is really a pity; the time is not far distant when every pole of English land will require to be kept in high cultivation most of the year, in order to keep pace with a stretching population, hungry as the famous Egyptian locusts. Well, all Cabbage-worts will bring to hand half-decayed leaves, which are useful to the swine, at least; and, as these are removed, advantage may be taken to cultivate between them, both for the sake of the existing crop and its successor. What is termed "soiling-up," although condemned by some, is, according to our experience, quite the thing; it prevents the plants wind-waving; it destroys a crop of weeds; it admits air to the soil; and it does more, it causes the plants to root up the stem, thereby rendering them more profitable.

RIDGING.—This was pointed to before; but as a good tale is none the worse for being twice told, we beg again to refer to it. Our advice, then, is, let every yard of land, on which no crop is standing in the end of November, be deep dug, and thrown into sharp ridges.

ONIONS.—Keep your Onions dry; yea, warm if you will, sooner than permit any damp to lodge about them. *Leeks*, if growing, as they should be in drills, should be soiled up like celery some dry day.

RHUBARB.—Those who want this early, with small expense, should cover the crowns with any dry litter as soon as the leaves can be stripped away, which will generally be in the first week of November. "An empty house is better than a bad tenant." And so with such things. Jack Frost had better be kept at a respectful distance.

CABBAGE PLANTS.—Let all those in seed-beds, not required this autumn, be immediately "pricked out" in store-beds, three inches apart. Ours are already done, the soil dressed well with the covering from charred heaps, in order to ensure a clean and healthy plant, which it assuredly will.

ORDER.—This is a strange title to finish with; but let everything be in its place, and walks and ditches cleared by the middle of the month. As far as our experience goes, order is closely related to thrift. R. ERRINGTON.

THE APIARIAN'S CALENDAR.—NOVEMBER.

By J. H. Payne, Esq., Author of "The Bee-Keeper's Guide."

THE requirements of the apiary are but few during the present month, provided that *feeding* has been well attended to in the last; should it, however, have been neglected, no time must be lost in setting about it before cold weather sets in, which may now reasonably be expected.

FLOOR-BOARDS.—It will be well to clean the floor-boards, and (the season for robbing being pretty well over, and the wasps having now finished their maraudings), to have a final examination of all the stocks, securing them well against wet, and making them up, by feeding, to eighteen or twenty pounds each.

REMOVING SUPERS.—All super as well as nadir hives should now be removed, reducing the room occupied by each stock as much as possible.

VENTILATION.—In hives of wood I have always found it necessary, during the winter months, to withdraw one of the slides at the top of the hive, and place over the opening a feeder, or small glass, for the purpose of carrying off the condensed vapour, which would otherwise run down the sides of the hive, and cause dampness and mouldiness to the combs, and sometimes the entire destruction of the stock. Mr. Taylor gives a drawing of a condenser for this purpose in his *Bee-Keeper's Manual*, page 142, fourth edition, which I have found to be very useful, where a feeding-pan could not well be placed.

NORTH ASPECT.—The accounts that I continue to receive from persons, who, at my suggestion, have thus placed their bees, are, hitherto, *all* in favour of it. The advantages arising from it during the late hot weather have certainly been very great, but we must watch it through another spring before it can be generally recommended.

DIVIDING HIVE FOR OBTAINING ARTIFICIAL SWARMS.—I have just received the following letter from my friend, Mr. Taylor, author of *The Bee-Keeper's Manual*, and as it contains much interesting matter on this and other subjects, I will give it at length, for I feel assured the writer will excuse my making use of it.

"I hope you will be able to preserve the dividing hive* through the winter, that we may see what becomes of it next season; so far as we have gone, we know the *principle* is right, and that the thing will *work*; though I am somewhat in the same sceptical position as to artificial swarms as are Dr. Bevan and Mr. Golding; of course, I mean as a general rule, for they are sometimes, doubtless, desirable, and it is well to have the means of accomplishing the business, which I think my hive does, without much risk, trouble, or disturbance. There are, however, other uses I have in store for it, as I mentioned to you, of equal, and, perhaps, greater importance than swarm making. Both Dr. Dunbar and Miner, speak of dividing hives, but I followed my own devices in making the one you have. The one alluded to by Dunbar, is, doubtless, that of Feburier, whose work he translated, though it was not published. Dr. Bevan told me a Welchman once brought him one of these

* I have had one of these hives, which was kindly sent me by Mr. Taylor, at work since June, and find that it acts perfectly, so far as taking to pieces goes, which may be done at any time, with very little trouble, and still less annoyance to the bees. This hive is so constructed, that I have no hesitation in saying that an artificial swarm may be obtained from it at pleasure during the months of May and June.

dividing hives to inspect, as an original invention, and, perhaps, it was even so, although it appeared an exact copy from Feburier's drawings. These I never saw, and am rather curious to know how far we agree. I should always be inclined to caution in accusing any one of plagiarism as to invention, or as to an original idea, particularly where bees are concerned, for hundreds and thousands of heads and hands have been at work on their behalf for centuries. I could name some instances in my own case. You will recollect when I told you, some years ago, I had been scheming to find out a mode and utensil suitable for feeding at the top instead of the bottom of a hive; I had never heard of such a procedure previously; but you had been in possession of a top-feeder for forty years; and, moreover, when Dr. Bevan's second edition came out, there was the very same thing, or nearly so. And so it was as regards feeding with barley-sugar, which the good Doctor recollected to have seen used by a friend many years ago, without farther thinking of it. By-the-by, if you want to defend the passage into a hive against an invasion by wasps, you have but to put a bit of barley-sugar across the mouth, and out will come such a body of bees that no enemy will face them. Repeat the dose as fast as they eat up their fortification, and the wasps will sheer off in despair. The idea came to me from Dr. Bevan. I once read an account of a new invention, by some one, for obviating the evil of damp in hives, in winter, by condensation, precisely the same as had been published by me for years. And yet, afterwards, I discovered that a friend had used the similar means two years before *me*, with success. So you see how often people hit upon the same ideas. I could mention other things; such, for instance, as a method communicated to me lately (as a secret), for washing a hive with salt and water previously to hiving a swarm into it—a practice I recollect in a district in Norfolk half-a-century ago. I saw it tried in two cases forty years since; in one instance with success, and failure in the other. Can it be right to insure a damp hive always in wet weather? Even *THE COTTAGE GARDENER* of the 16th of September furnishes something like an example of a similar nature, where fumigating a hive from the top is alluded to, as if it were something new. All my editions, I think, mention it; but at pages 104 and 124, *third edition*, and page 138, *fourth edition*, it is described. Whether I was the first to think of it, I do not know; but I have often practised the thing (particularly down the ventilators in Nutt's hives), though, in general, common hives do not offer the necessary facilities. The requisite tube is a bent one, which, if you were a *smoker* instead of a *driver*, I would send you. I am inclined to agree rather with Dr. Dunbar, who is a mighty champion for smoke, in many operations on bees. However, we all have our own fancies in such matters, and, perhaps, it is as well each to practice what he best understands and succeeds in. I ought to have said, that the instrument I always have used is what is called the Oxford tube, a moveable one, as opposed to the lamp form, which seems only adapted, as I conceive, to *bottom-fuming*. Even for that I like the other best, as more easily regulated.

"And now you will like to hear how the Observatory hive goes on, in which, as I told you, the bees had from the first been working, exposed to the full glare of day-light. Of course, work is pretty well over; but there is a fair store of honey. I never lost sight of the queen during an inspection of half-an-hour yesterday; she is become sluggish and inactive, and not an egg proceeded from her, though a while back she laid them incessantly, to mere waste. I think I told you she was a *young* lady; but I have since found that the swarm was a prime one, and her appearance confirms it. Her extreme fertility had almost made me a convert to the doctrine of young queens as the best breeders, which, you know, I had many doubts about. My own observations would seem to lead me to the belief that a queen bee does not arrive at her full powers at first. Dr. Bevan spoke decidedly on this point in a letter, which I think you saw. For myself, I have observed that an early second swarm, and a late first one, coming at about the same time, and not much differing as to size, did not prosper as well relatively as might be expected, one queen being young and the other old; the latter, in short, increasing the population the soonest and the most. It might not be so always,

perhaps, though a second swarm rarely becomes very populous. At all events, the question of advantage rests in so much equilibrium, that I had rather, in most cases, let nature alone, unless in some obviously extreme emergency. The *oldest queen* on record was one of Mr. Goldings, which, at four years of age, or nearly so, filled the hive so full of brood of all kinds before she died, that a large swarm issued soon after (in May), and four more subsequently. As regards the question of bees working in the light, I can only say, that so far as I have seen, they appear to care nothing about it, *if used to it from the first*. Alternations between light and darkness does not do; and they are alarmed where one or the other is not continuous. I saw a hive thus working, exposed to the light, many years ago, I think at Oxford; but the experiment, I believe, is hardly likely to lead to any very useful practical result beyond ascertaining a fact. I mentioned the hive I am now working (altogether of glass at the sides) to a friend, who told me he once saw a number of wooden hives at work, and all without shutters to the windows, of which most of the hives had two. The owner, in answer to a question, replied, that he found the bees did not care about the light, and he left

off making shutters to save trouble. In winter, I should say they would be needed; and, on the whole, I should prefer them. However, you shall judge for yourself next year, when I hope to send you a *light hive*. The good old Doctor is to have one; and he tells me he has already in his mind decided as to where it is to stand. We have just emerged from an argument as to the nature of a *drone egg*, leaving off where we began. You will be grieved to hear that his eyes have failed him of late; his own admirable hand-writing being of late exchanged for that of a secretary.

"I mentioned to Dr. Bevan that the Entomological Society had offered a prize for the best essay on the duration of life in bees, of which I thought he knew more than any one. He says he could do no more than repeat what he has already written. The question, indeed, appears to me to have been settled fifteen years ago by him, Dr. Dunbar, Mr. Golding, and, I think, Sir William Jardine, beyond farther dispute (see the "Honey Bee"). But, judging from what has recently appeared as to bees in the name of one of the magnates of the said Society, they do not seem aware that the world has kept moving of late years."

FLOWER-GARDEN PLANS.—No. 1.

THIS, the first of our series of flower-garden plans, was sent to me before the subject was announced for publication. The author is a friend, and a clever gardener, and he had no idea at the time he sent it, that either his "tracings," or anything about them would ever be made public. Having fixed on this plan for our first number, some delay was necessary, to obtain his consent to publish it. He made no observations on the plan the second time, and all that he said in the first letter, was this—"I send you tracings of a flower-garden, which I have some thoughts of laying down here. What do think of it? The colours I merely put down for your good-natured criticism. But I always think a *few well-defined and distinct colours* better than a larger number. Don't you?" I do think so, for that is the grand secret, after all, of planting a flower-garden for effect. Some plant more, to show the extent of their bedding-plants, their scarcity, and so forth, and pride themselves on the greater number of species or varieties they can thus introduce, and when the space is large enough, and the sizes and position of the beds are such as to allow of all that being effected in "a well-defined, and distinct manner," that kind of pride is very excusable. Some day or other, I shall give the best instance I know of that way of planting a large flower-garden. Meantime, I shall give two reasons for fixing on this for the first plan; first, because the colours are given without mentioning the plants for producing them; thus leaving the field open for young planters of both sexes to exercise their taste a little, and send us the names of such plants as *they* would plant in this garden, and this I earnestly invite young artists, as we may call them, to do. Then, after a few months, I shall criticise all that are sent to me, and give the way I would plant myself. As the plans will be numbered, there will be no difficulty in referring to any of them at any future time, and there is a long time before us, between this and next May, without any occasion for pressing on our different styles of planting. All the time that I served at Shrubland Park, the final arrangement of the flower-gardens there was not settled before the middle of April, and those fine gardens have been allowed to be among the very best in the country; and in another year or two, when the whole of the great improvements now going on there shall have been completed, I should not be far

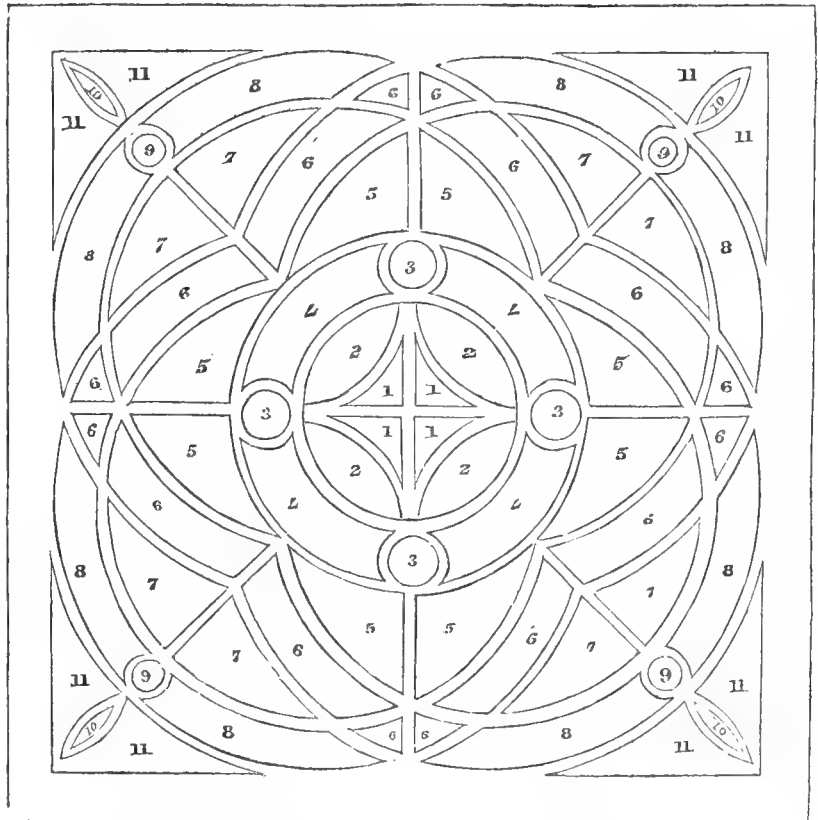

- | | | |
|-----------------------|------------|----------------------|
| 1 Blue. | 5 Blue. | 9 Bright pink. |
| 2 Dark purple. | 6 Yellow. | 10 Brilliant orange. |
| 3 Dwarf box, clipped. | 7 Scarlet. | 11 White. |
| 4 Bright pink. | 8 Blue. | |

from the mark, if I were to say that would be the finest place in England for flower-gardens; and then I venture to say that it will be late every spring before they will settle how the whole is to be planted.

My second reason for this plan is because my friend has introduced a new feature in it, for the first time since I began to plant flower-gardens. I mean his introducing Box as a *relief*, or green colour in beds No. 3, between the dark purple in beds No. 2, and the blue in beds No. 1. This style is all but quite new in this country. I only know of a few places where box-beds, or beds of some flowerless plants are used; but on the Continent, I hear the plan is common, and I know that some old foreign authors treat of this style as quite familiar. The different coloured gravels, pebbles, and sand they use in Italy, in their Italian gardens, is part and

parcel of the same; but here, with our moist climate, and our superabundance of half-hardy and fine-leaved plants, we need not resort to such extremes. Yet, white sand and yellow gravel formed good auxiliaries to many of Lady Middleton's compositions, which we had to fill up; and I know of several places in which some of the old Cape Geraniums, with inconspicuous flowers, are used this way, with very good effect as *reliefs*, as we call them; a new name that I shall have to use often in this series. Then we shall have *neutral* beds, *relief* beds, *mixed* beds, or subdued colours, as well as the more common terms of *harmonious* beds, and beds *contrasted*. I am anxious to have box beds, and box scrolls introduced into geometric gardens, as well as Yuccas, Irish Yews, and a little dwarf Spruce called *Abies Clanbrasilensis*. These last two for strong contrast; the Irish Yew as a slow-growing and fastigate, or quite upright growth; and the *Abies* of much slower growth, and quite flat on the top, with a round head. Also the Irish Furze (*Ulex stricta*), and *Juniperus prostrata* and *squamata*, for the same purpose—strong contrast.

The Irish Furze, or Gorse, is a highly architectural plant; quite as much so as the Irish Yew and Yucca. It was first discovered in the Marquis of Londonderry's Park, in the county of Down. It is soft and silky in the leaves and branches, and bears the knife so well, that it may be formed into almost any shape; square on the sides, round, and sharp-pointed, or flat on the top. The prostrate Juniper makes a beautiful bluish-grey carpet to fill a round bed with, and it can be cut to any shape, and is also a fast grower in good soil. The same are the characteristics of the Juniper called *squamata*, only that it is a stronger growing plant. It could be made into little weeping standards a yard high in the stem, and then be allowed to weep down gracefully on all sides. The culture and propagation of them, as novelties, for the geometric garden, I shall explain shortly; mean time, I have one or two observations to make on the plan before us.

I object to the four entrances at the two ends and two sides, in a garden of moderate extent, unless you have a walk all round it, or a terrace on one or two of the sides; it lessens the effect of the picture, if you allow your visitors, or "company," to walk on straight to the middle of the scene at once, as they will be sure to do, seeing a straight leading walk before them, and as sure as they do, one-half of your garden is, in a manner, lost to them. This is a prevailing fault all over the kingdom, and in compositions, otherwise most beautifully arranged, I would prefer each pair of beds, No. 6, to be united as they now stand, or to be circles or ovals, at the expense of having more gravel at each end. Then your visitors are put off the "follow-the-rest-like-the-sheep" way of looking over the garden, and still they have a choice of right and left, and then the chances are, that some of them will go this way, and some the contrary way; always a lucky hit for the gardener, who prizes himself on his pet points. There may a trick in this, but depend upon it, the thing is as I say, for few gardeners have had more experience in leading companies through such scenes than your humble servant, to whom all this is as familiar as A. B. C.

I highly approve of beds, No. 3, being planted with dwarf box, and that as thick as possible, to be clipped on the outsides like an edging of box, and either as flat on the top as a dining-table, for the sake of uniformity, or as round as a globe; and if rounded on the top, the height to be in proportion to the diameter of the bed. In this instance 18 or 20 inches would be about the proper height.

I would prefer the circular beds, No. 9, to be green also, but not with box; then all the circles would be green—that is, uniform; a capital and practical explanation of the word, as we gardeners apply it; but how can we make a *variety* in a thing we call *uniform*? Nothing in this world so easy; plant No. 9 all round with the Rose-scented Geranium, and keep the growth regular with the knife all the season, and the thing is done to a T; and how lucky that 9 is so far from the centre, and from the middle walks, and, therefore, requiring a higher plant than No. 3, which is under the eye. Still my alteration for No. 9 is not a principle, and I have no right to insist on it, being only a matter of taste or opinion. The disposition of the colours by the author of the plan has my unqualified approbation.—D. BEATON.

EXPERIMENTS ON FEEDING COCHIN-CHINA AND SPANISH FOWLS.

I HASTEN to redeem the promise I made, of stating the results of my trials as to what was the cost of the food of Cochin-China fowls, as compared with that of others.

In the course of a few days, I hope to be able to say what has been the consumption of food (under exactly similar circumstances) by Dorkings, Bolton Grays, and some more Cochin-Chinas. In the mean time, it will be seen that these experiments very nearly verify what Anster Bonn, some time ago, in THE COTTAGE GARDENER, assured us was the case (though her opinion since then seems entirely to have changed), viz.:—"That when common poultry are fed twice a-day, it is necessary to feed Cochin-Chinas three or four times, and to give the food so abundantly that some may be left after the fowls have satisfied themselves." For while Spanish fowls have eaten at the rate of 2d. a-week, the Cochins have cost 3½d., 3¼d., and 4d. This has been, of course, where there is no farm-yard, which is, I think, Anster Bonn's case.

Before detailing how these trials have been carried on, I may add, that I give you my word that they have been tried in the fairest possible manner. Nos. 1, 2, and 4, have been carried on under my own eye. The food weighed out, and the birds almost entirely fed by myself.

In 1 and 2, the birds had the range of a wire cage, about 16 feet by 9 feet, with a small house attached to each cage. I believe the children were in the habit of feeding them with bread, &c., but the poultry never left the inclosure during the week. They were also supplied with green food.

No. 3, besides being fed as by the list, had the run of a large plantation and a stubble field. I have published the weights, which (varying as they do, some having increased, some diminished) may interest your readers. This lot was not under my own eye, but I have great faith in the accuracy of the person who carried on the trial.

No. 4 had the run of a large grass field and plantation. I am quite sure of the accuracy of the quantity of food consumed, and you will see, that under similar circumstances, a lot of thirteen Spanish poultry, of various ages, ate very little more than five Cochin-China cockerels.

The Spanish hens in lot 4 were deep in the moult, and laid no eggs; but, pray observe, that the Cochin-China eggs (few in number as they were) did not average *two ounces* each. I may add, that I have a Spanish pullet who now lays eggs weighing *three-ounces-and-a-quarter*. These are facts, which I leave to the consideration of the readers of THE COTTAGE GARDENER; but I ought to say, that I thought the fairest thing would be to buy my corn in small quantities (by the bushel), as a cottager would be forced to do. The prices I actually paid, were for

Barley, bushel of 60 lbs.,	4s. 6d.,	1d. per lb.
Wheat, "	70 "	6s. 3d., 1d. "
Indian corn, "	60 "	4s. 0d., ¾d. "
Meal, "	60 "	6s. 3d., 1¼d. "
Bran		¾d. "

These are the weights and prices of this county for good food, and I believe it will not answer to a gentleman or a cottager to feed poultry on bad food.

I leave my cause to plead for itself, believing that *truth will out*. I fancy it is even now prevailing, as I have letters before me from three poultry fanciers, who do not know me as "Gallus," but who write—"I am relinquishing a capital breed of Cochins. I wish to revert to the Spanish, which I once kept. The former are certainly good layers, and very hardy, but their eggs are very small, especially when compared with the Spanish, and they are *enormous eaters*."

"I am giving up Cochins. They are good layers, hardy, and good flavoured, but they are *enormous eaters*, their eggs very small, and they are very awkward-looking birds when cooked, their thighs being so large, and their breasts being *anything but plump*."

"I have been in the habit of keeping poultry for several years, and have calculated their cost per head, in the summer months (say from May to August) at *about 1d.* for hens, and 2d. for cocks. From August to May, when they require better food, they cost me 2d. per head, besides which they had scraps from the house. The breeds I keep are Spanish, Gold and Silver Pheasant, and Game. I tried

the sort now so much in fashion (the Cochin-Chinas), and I considered they ate about double what the others did."

So much for the opinion of three unprejudiced people! I have only further to say, that if any of your readers still think that 1d. a-week will keep a Cochin-China fowl, let them (as I did) weigh out 1 lb. of barley (which is about that value), and see how soon a Cochin-China will eat it.

I believe we deceive ourselves in saying "our poultry only eat so much," for we forget the bread, the potatoes, and other scraps, which would, if the cottager kept a pig (as I advise every one to do), go towards its food, instead of to the poultry, so that if the fowls cost less, the pig costs more.

I am very glad, for my own sake, that I made the experiment, and I am firmly convinced that the time is not far distant, when many now opposed to me will be ready to own I am not very far wrong.

GALLUS.

Time of Experiment—Oct. 4 to Oct. 11.

Lots	Description	Age	Weight		Quantity of food consumed	Cost	Weekly average	No. of eggs	Weight of eggs		
			Oct. 4	Oct. 11							
1	Cochin-China Cock	1851	Not weighed.	Not weighed.	lb. oz.	d.	3½	4	8		
	Cochin-China Hen	1851			Meal 3 15	5					
	Cochin-China Hen	1851			Bran 2 0	1				Corn 5 2	4½
					11 1	10½					
2	Cochin-China Cock	1851	Not weighed.	Not weighed.	Meal 4 2	5	3½	6	11		
	Cochin-China Hen	1851			Bran 1 15	1					
	Cochin-China Hen	1851			Corn 5 5	5					
					11 6	11					
3	Cochin-China Cockerel	1852	Not weighed.	Not weighed.	Meal 4 0	5	4½				
	Ditto ditto	April			8 5	8 4				Wheat 14 0	1 2
	Ditto ditto	May			7 13	8 8				Pota- toes 5 0	0 2
	Ditto ditto	June			7 0	7 9					
	Ditto ditto	June			6 14	7 9					
	Ditto ditto	June			5 14	5 12					
					23 0	1 9					

Time of Experiment—Oct. 7 to Oct. 14.

4	Spanish Cock	1850	Not weighed.	Not weighed.	Barley 7 0	0 7	2				
	Spanish Hen	1851								Wheat 6 0	0 6
	Spanish Hen	1851								Meal 5 4	0 6½
	Spanish Hen	1851								Bran 2 8	0 1½
	Spanish Cockerel	1852								Indian Corn 4 0	0 3
	Spanish Cockerel	1852									
	Spanish Pullet	1852									
	Spanish Pullet	1852									
	Spanish Pullet	1852									
	Spanish Pullet	1852									
	Spanish Pullet	1852									
					24 0	2 0					

[NOTE BY THE EDITOR.—We readily declare our belief in the accuracy of the above report, because we know the writer to be an honourable man; and we have but two objections to make to his experiments, and they are these: First, that he did not have his Spanish fowls separated into threes and five, the same as the Cochin-Chinas. This is not an objection for objection sake, but founded upon our own experience, and the experience of others, that two or three fowls by themselves will consume proportionately more food in a day than when a great number are fed together. Whether this is the result of the few being less interrupted, and having less to divert their attention from the food trough, we shall not attempt to explain; but this we know—fifteen fowls fed together eat less in twenty-four hours than the same birds divided into threes, and fed each three in separate places, eat in the same space of time.

Our second objection is, that we have not the weights of the full-grown Spanish fowls, as well as the weights of the full-grown Cochin-Chinas. We suspect that the weight of the latter must be nearly double the weight of the former, and, if so, it is not so great a marvel that they eat nearly twice as much.

We have tried one experiment ourselves upon this subject very recently, and it yields a very different result, explicable upon no other grounds, as far as we can see, than that the birds were all fed together, and that ours in the south have not the keen appetites bestowed upon their brethren in the north, by its colder breezes.

Our experiment extended from Oct. 13th to Oct. 19th, both inclusive. In one yard were fifteen cockerels, and in

the other twenty-seven hens and pullets, all pure-breds, from the stocks of Mr. Punchard, Mr. Moody, and Captain Hornby, with the exception of three hens imported from Shanghai, and two hens, crosses between Cochins and Dorkings. Their respective ages and average weights (in the morning, before being fed) were as follows:—

	lbs.
9 cockerels, aged three months, average weight	- 2
4 cockerels, aged four months, average weight	- 4
2 cockerels, aged six months, average weight	- 6½
8 pullets, aged three months, average weight	- 1½
6 pullets, aged four months, average weight	- 3¼
9 pullets, aged six months, average weight	- 4½
6 hens, average weight	- 6

They were fed upon the following articles, to which we append the weight and price:—

Barley-meal, 46 lbs. per bushel, 3s. 9d.

Barley, 42 lbs. per bushel, 3s. 9d.

Oats, 35 lbs. per bushel, 2s. 9d.

Rice and greaves, averaging 1½d. per lb.

They were fed in troughs, barred across the top, so that they could not trample in the food, nor waste it in any other way; the troughs were never allowed to be empty, and they had a roomy yard, with access to grass for an hour or so daily. The supply of water unlimited. They consumed during the time—

25½ lbs. barley-meal	- - -	25½
4 " bran	- - -	2
14 " oats	- - -	14
14 " barley	- - -	14
4 " rice	- - -	9
2 " greaves	- - -	9

63½ lbs.

64½ pence.

So that the 42 fowls consumed food which cost 64½d. in seven days, being scarcely more than three-halfpence per week each. If this had been a cheap potato year, so that boiled potatoes could have been partly substituted for barley-meal, we are certain that the expense would have been nearer five farthings a week. As in the experiments by "Gallus," the corn was bought of a retailer; if bought by the quarter it would have been somewhat cheaper. During the week the six hens laid seventeen eggs, weighing from 2¼ to 2½ ozs. each, and two double-yolked eggs, weighing 3 ozs. each.]

Anster Bonn in a letter, from which the following is an extract, says—"I enter on the subject now, for this last time, from a desire to reply, with all willingness, to "Gallus's" question. At the dinner to which he refers, the opinion of the fowls in the dining-room was not pronounced so decidedly as out of the dining-room, because it was, on both sides, somewhat repressed by politeness. Although, from keeping but one kind of fowl, I lack the opportunity to join in "Gallus's" experiments, I shall feel great interest in their result; in aid of them, I can only offer the knowledge which I possess. The cost of corn and meal of various sorts to me, during the whole month of September, was £3. 4s. 6d, and the number of fowls being 140. This (about five farthings a-week each) gives rather a greater increase on the preceding months than I expected; but among these fowls are included fifty cocks near maturity: an extravagant disproportion, which would scarcely be tolerated by persons desirous of feeding with economy."

VISITS TO SOME OF THE CHIEF POULTRY-YARDS OF ENGLAND.

[MR. STURGEON'S.]

TIME was, and that within the memory of those who do not wish to think themselves old men, that a trip down Father Thames to Gravesend was an uncertain, and therefore somewhat serious undertaking. If the wind was favourable, and the tide suited, the light little river craft, then called "packets," ran you down merrily enough; but if the breeze failed, and the tide was against you, great was the consumption of patience—and tobacco. Independent of the wind, and comparatively but little affected by the tides,

the introduction of steam-boats put a new face upon the matter, and ultimately the formation of the Blackwall Railway, and an arrangement between the Directors of it and the Steam Packet Companies, to run in connection with each other, have reduced it almost to a certainty. By these means the inhabitants of "Cockneyshire" exchange the smoke of the city for that of the steamers upon the Thames; enjoy a stroll over the new town of Gravesend, and drink their own porter in the gardens upon the hill, where, at the time we have first referred to, we used to shoot rabbits. Of these gardens we may again speak upon a future occasion, but it is of a spot at an intermediate stage of the journey that we propose to-day to discourse.

We will suppose, then, that the reader has taken his ticket at the Blackwall Station. For 1s. 2d. by the first, or 10d. by the second class, he may travel by rail to Blackwall, and thence by the steam packet to the village, once, we are told, the market town of Grays, which is situate on the Essex side of the River, three or four miles before you reach Gravesend. One of those useful wooden piers, so common upon the Thames, runs far enough into the river to enable the steamers to land their passengers in any state of the tide, and for this accommodation sixpence additional is charged.

Leaving the toll-house behind you, you will observe, at a distance of a hundred yards or so, an old square manor-house. This is the dwelling of Mr. Sturgeon and his family; and let us whisper to you, kind reader, that if you are often in the habit of visiting a more hospitable mansion, you are, in our opinion, an exceedingly lucky fellow. We assume that such of our readers as are poultry-fanciers will have heard and read, more or less, of Mr. Sturgeon's Cochinchina fowls; and having told those who were not before aware of it how to reach their abode, we are now about to communicate to such as are unable to avail themselves of that information and to see for themselves, the result of a recent visit to Grays. Let us say, first of all, that here is no pretension to a handsome or costly poultry-house. The Messrs. Sturgeon farm a large tract of land; their poultry, consisting of Cochins exclusively, are kept as part of the stock of their farms; and all that is aimed at in the buildings and places in which they are located, is just sufficient to insure their health, their comfort, and their safety. There is, moreover, none of the nonsensical mystery of concealment—learned, we suppose, from the tricks of the dealers—which are seen in the yards of some of our fanciers; at Grays all is freely shown, and all as frankly told. The history of Mr. Sturgeon's flock is a brief one. His first birds were a present from the captain of a vessel, who brought them direct from Shanghai. The cock was killed by a fox, and the stock was reduced to the hen, which was sitting, and her embryo brood. From these, with the addition of such new blood as he has been enabled more recently to procure, the judgment and attention of Mr. Sturgeon have produced his present magnificent stock. Let our young fanciers derive hope and encouragement from these facts, for each of them has now better opportunities than, five years ago, Mr. Sturgeon possessed.

We have stated that there is no display at Grays. At the back of the house, at a corner of the kitchen-garden, is a plain shed, much such an one as we shall presently have occasion to describe; in this Mr. Sturgeon's breeding birds, or the best of them, abide during the spring months, and their "walk" is a part of the kitchen-garden. It is fenced off from the rest by a length of wire, over which you can step, but which the birds never attempt to pass, so easily are they confined. They run about under some raspberry bushes, and among the cabbages; and we were surprised to see how little mischief they appeared to do. The floor of a small grapery, at the opposite corner of the garden, is given up in early spring to the young broods, who have here light, air, and warmth, and are allowed to run out a little in the middle of the day.

At a distance of a few hundred yards from the house, and near to a little wood, sloping to the south, is the cottage of the intelligent man under whose care the birds are principally placed. Adjoining this cottage, and at a little distance from each other, are two sheds, measuring perhaps (we speak from memory) fifteen feet by ten feet, built of wood, and thatched with reeds from the marshes. There are no

perches, the floor being of open rails (perhaps three inches wide), and the rests are composed of wooden partitions at the end. Excepting those located, as we have said, in the garden adjoining the house, these are the dwelling-places of the best of Mr. Sturgeon's stock, their run out being into the wood and field adjoining. At Ockenden, about five miles from Grays, is another farm occupied by Messrs. Sturgeon. Here are a mill and a lodge-gate, at each of which places a similar plain shed is erected; and in these, and one or two more such at convenient points on the farm, the rest of the birds are parcelled out in lots. Our readers will see, from this simple description, that, although they may, perhaps, not need so many, it is not difficult for them to provide for their feathered favourites places of abode to the full as good as those which Mr. Sturgeon finds sufficient for his. We should ourselves suggest the addition of a perch about eighteen inches high, for which we have found nothing so good as a fir pole split down the centre, the round side being upwards, and the bark left on.

It remains to say a few words of the birds themselves, for it is to them, in truth, and not to see the places in which they are kept, that a visit to any poultry-yard should principally be paid. The prevailing colour of Mr. Sturgeon's birds are the different shades of buff and yellow, with such an admixture of other varieties as the most judicious crossing cannot prevent. The system of dividing them into lots, suitable to the amount of accommodation afforded by each "walk," and of separating the sexes as soon as they are fit to leave the mother, which the number of Mr. Sturgeon's separate "walks" enables him to carry out, promotes the growth, and improves the plumage of the young birds. Having bred, during the two last seasons, extensively, he has had abundant opportunity to select the most perfect in form and colour, and his judgment has made the most of his opportunities. Hence it is that Mr. Sturgeon's birds have carried off the prizes at all the shows (save, we believe, one) at which they have been exhibited, and although others may, and probably have, bred some birds as good as his, we doubt if at this moment any poultry-yard in England can show so many good, with proportionately so few indifferent, Cochins. A reference to our advertising columns shows that our readers may have an early opportunity of testing for themselves the correctness of the opinion we have expressed by looking in at the sale of Mr. Sturgeon's surplus stock at the Baker Street Bazaar, on the 2d November, and perchance some of them may even become the purchasers of some of the fowls of which they are now reading an imperfect account.

We should, perhaps, add, that there is nothing particular in Mr. Sturgeon's mode of feeding his poultry; the different species of our own grain, some whole and some ground, and mixed with water (a little sweet milk, where it can be spared, is an improvement) with occasionally a few tallow-chandler's greaves, being the staple of their food.

We take leave of Mr. Sturgeon and his flock, sincerely wishing him a good sale, and thanking him and his family most sincerely for their courtesy and hospitality to those whose good fortune it has been, like our own, to visit them at Grays. B.

THE SHELDRAKE AND ITS HAUNTS.

(Concluded from page 51).

The stile at the foot of the wharf (nobody can call it a *quay*) is mounted, and here at once is a charming and novel promenade. On the left, just across the channel of Blake-ney harbour, are the salt-marshes, in the state they remain from natural causes. We will have a stroll over them another time. On the right are the valuable marshes of Cley, reclaimed by the simple but costly erection on which we are treading. Several hundred acres have been inclosed by a mound of clayey soil. The ditch formed by its excavation acts as the main drain; a sluice-gate lets off the superabundant water at lowest ebb,—and that is all. *Here* are fat sheep and oxen grazing; *there* are gulls and all sorts of odd things. *I like* the odd things, and hope they will not be exterminated; but they will have a hard battle soon. From this to Weybourn all is to be brought into trim order; and then the rest of this line, as well as the marshes round

the other corner of the coast, will follow. Were I only born to a thousand acres of salt-marsh, half of it should be devoted to the preservation of unpreserved game. But the local papers already display a long advertisement headed, RECLAMATION OF LAND, and concluding with a signature, "Solicitor to the Bill." Farewell to the salt-marsh of olden time. Farewell to wild swans, ruffs, and reeves, and sheldrakes.

The circumvallating ridge makes a bend, and we now have a fine view of what, were we out at sea, would be called the line of coast, for the sandy flats and marshes are thence invisible. The parish church, standing on elevated ground, is the central object, with its curious supplemental beacon-tower, and the low sunlight gleaming through its windows. On the left are the pudding-shaped hills of Sheringham and Weybourn; behind that broad and lofty knoll on the right, dwell the cockle-gatherers of Stiffkey. Yes; take care of your hat: till to-day you hardly knew what "an airy situation" meant. Other breezes may waft the luxurious odours of the spices of Arabia; this bears something better on its wings,—a healthy, hungry appetite. *This* chestful of air, at least, has not passed through a thousand pair of lungs before entering mine. If one had but in one's frame-work a reservoir for fresh air, as the camel has for holding a store of fresh water, it would be worth coming here to breathe once or twice a week. Talk about plants and shrubs purifying the atmosphere, and throwing off oxygen! give me this, fresh from the north sea, for the gale to blow in *my* winter-garden. How delighted the little wavelets are, jumping in the harbour, running races to the shore, and friskily displaying their white shirt-frills! Give them a little more room, and they would soon grow into sturdy full-sized breakers. 'Tis a comfort to know that we could not lose our way wandering along this bank, even if we were caught in a fog, or had lingered after dark.

The tide is ebbing, and the boat awaits us. To get to it, we must pass—what were under water when we mounted the bank—the small pits, or dépôts, where shell fish are kept for daily use,—shallow hollows, dug out on the shore, ten or twelve feet, more or less, square; for the squareness is as uncertain as the size. *Parcs aux huitres*, or oyster-parks, the French would call them. Each pit seems to contain a small collection of mussels at one end, and of oysters at the other. See that rough-looking fellow with his mussel-rake, of eight or nine flat iron teeth, through holes in which a coarse net is laced. In fact, the implement is at once a rake and a landing-net; with it, he first collects his treasures in a heap, and then lades them out to the dry land, to be picked and cleansed, and packed in hampers. Mark the oysters, too, mostly lying with the *hollow* shell upwards, their natural position in the sea, instead of, as we have seen them packed in barrels, with the *flat* side uppermost. Oysters in the sea, laid wrong, will contrive to move till they get themselves right. People who doubt the vivacity of the oyster should visit these pits on a hot summer's day; the spitting, and spurting, and rattling of the assembly, will astonish them. The whole bed of the channel, or "cut" whereon we are about to embark, is covered with oysters and mussels, belonging to different proprietors. These chain cables, reaching across the bottom from shore to shore, mark the limits of each. Great part of our way down to the cockle-grounds will be over oyster and mussel pits or "lays," as they are called, stored with growing or fattening fish: oyster-parks, also, on a larger scale; for the oysters are dredged along the coast, and brought hither; and the mussels, too, are fetched principally from Lynn Deep and the Wash. Those *musselmen* who are not pressed for ready money, find that it pays to let these mussels remain *two years* in Blakeney "lays;" they grow and improve so much by the change of water. A mussel, when it comes to table, can hardly be less than four years old; a periwinkle, five or six. Cockles attain an indefinite age; in proof whereof the best and finest samples are only to be had from newly-discovered beds. You will note in returning, when many of these pits will be left by the tide, that the mussels are laid in deeper water, and much less exposed to be deserted by the tide than oysters. The smaller mussels, that have not thus been put up to fatten, are, in England, used rather for bait than for human food. The fisherman scoops out the

mollusc with his knife, and attaches it to the hook, raw. Whelks, which are also used as bait for cod-fish, are cracked with a hammer on a stone, and hooked *alive*. They are the best of bait; so tough that they never drop off, even if they are not taken by a fish for a week. Whelks are collected on several points of our coast, and are eaten largely by the children of the natives, although not by townspeople hereabouts. For the youngsters they are simply boiled; when adults partake of the mess, they are usually finished off in the frying-pan. Neither these, cockles, nor periwinkles, are kept alive in *vivaria*, or pits, or *parcs*, but are gathered, for the occasion, from their native.

The boat is manned by our polite host, who takes the helm, and by a second hand—in appearance a round bale of blue flannel, standing on two posts, that are encased in blue worsted stockings, and terminated by a short leather casing, to represent shoes. The entire package shall be veiled under the assumed name of Mr. Blackfaced Broadback, if it is possible to conceal anything so bulky. The sail is available for this reach. Down we glide. Overhead flits a pair of curlews, whistling their measured cry. The gun is on board: it would be pleasant to take home a few fat specimens of those. The culinary world is scarcely aware of their roasting merits. We turn to the left, and enter "the Pit:" the sail must come down. A pair of oars with the tide will carry us fast enough. A little flock of Stints wheel round us, and alight on the muddy shore that has arisen from the waves not ten minutes ago. Paddle gently up to them; there they run. Make ready! Present! Bang! There lie some of them; but how to get them? We've no dog. The boat is run aground. In jumps Broadback, up to the thickest part of his blue posts. *He* care for wet feet! Well, the game is not much, though some. Off quickly, or the tide will leave us stuck fast here. The *cockle-iferous* sands are yet too *quick* to venture on; what shall we do? Here's the pilots' house, standing on that wonderful tongue of sand and shingle, called "The Meals," before alluded to. Let us get out and walk, for we have at last arrived at the land of the Sheldrake. This is the *tide-pole* belonging to the pilots, reminding me of what I knew of Robinson Crusoe's almanac in younger days—a northern nilometer, measuring (upwards) the depth of the German Ocean. "What water was it at the pole?" is the twice-a-day question at Blakeney. They are not Trinity-men, but privileged denizens. Eight is their number,—four at a watch. None are here at this state of the tide, so we must be content to peep in at the window. The glass is dull; but the little round hole, through which their telescope is thrust, has not that defect. See, they have bed and board; that is to say, hammock and bench. In the middle is their stove, to heat the kettle and fire the frying-pan. It is placed *there* to economise warmth by its flue. Those square boxes contain each its owner's signal lantern and apparatus. One specimen lantern hangs on the hook there. The hut is but a dingy hole; still we should think it a paradise, if we were dragged into it after having been shipwrecked on the *sea-side* of the Meals. Yesterday I saw a woman (the wife of a master of a collier) who last week passed two days and a night lashed to the mast of a wreck. She was just beginning to recover the shock to body and mind.

Walking around the hut, one says that the pilots might improve their fashions; they are too Scotch in some matters. Proceeding, we find ourselves in a new world. How absurd to run over to the continent for *novelty* alone, till a man has ascertained what there is to see in his own country. Sand, shingle, and mud, are our three elements, or rather materials here. Wind and water are the two rival autocratic powers. The wind has a powerful ally in the Marram grass. *Wind* steals sand from the beach; *Marram* appropriates it, and keeps it. Mount this hillock, and the dodge is detected. You will also learn why sheldrakes are styled burrow ducks. Sand-wreaths are formed on the same principle as snow-wreaths, and do not melt. In these the rabbits burrow, and prepare nesting-places for the sheldrakes. Our dry sandy shores produce another grass, the *Poa bulbosa*, peculiarly fitted to inhabit such ground. Its bulbs grow in clusters, resembling little shallots, and during most part of summer remain inactive, blown about at random. With the autumnal rains they vegetate, fix themselves

by long downy radicles, then produce thick tufts of leaves (a grateful spring food for cattle), and in April or May they flower, having in the meantime formed young bulbs, which, as soon as the herbage withers, are dispersed like their predecessors. This summer dispersion is the cause why the plant remained so long unknown to botanists. Has any one been here with a vast bread-grater, and grated brown-bread crumbs over that muddy hollow of four or five acres? They are the casts of the marine worm, which here socially enjoys itself. The bottom of the next pool is dotted with an infinity of black spots, not the size of a peppercorn. Look at them: they are baby periwinkles, to make feasts for human babies that are as yet only "on their way." These are the food of the tender sheldrakes; with a daily supply of these, I could have reared my pretty pair.

Correspondents pester editorial gardeners to know what ornamental shrubs will grow within the influence of sea-breezes. We are in the midst of patches of one that would ornament any lawn. The *Salicornia fruticosa* has the unusual appendage of evergreen, succulent, hardy leaves. Are you gardeners enough to make it grow with you? I have managed to keep it alive for a year or two.

What a regiment of gulls!—young birds mixed with those in adult plumage,—with "old Mows," as Broadback calls them. "Shute them? Might as well shute at a Grinlin (Greenland) bear! Them there things, and the Danish (hooded) crows too, know when anybody have a gun, as well as what we do!"

Time passes, we return to the boat, and find the channel of "the pit" and "the harbour" inclosed between high walls of shingle sand, the mass of which is found to extend daily. All that point, from the pilots' house to its end, has been gathered by the waters within the last six-and-twenty years, and is still increasing. Before embarking, we will root up a few botanical specimens, and, for private reasons, I shall make free with this rusty piece of old iron hoop.

We are again afloat; the cockle-ground over the way is in capital order; but, get as near as we can, there are many yards between us and dry land. Broadback is overboard. A ride pick-back on that blue bale of flannel saves us wet ankles, though we will say nothing about wet feet. What painter (Copley Fielding, perhaps) could put this scene within a gilt frame? Miles upon miles of trackless sands! We will stick up this bit of drift-wood, as a land-mark, in case,—who can tell? Sudden fogs, or spring-tides, might puzzle us to find the boat.

But is this the famous cockle-ground of Norfolk? Where are the cockles? None are to be seen. They are here, nevertheless. Now for the use of our old iron hoop. We will give it a preliminary flourish, for luck. Who wants shaving?

To business! Half-a-mile off is a fellow stooping at work. Let us join him. In one hand he has a wooden cockle-rake,—a short-handled thing, set with iron teeth; with the other he picks up the cockles, and throws them into his basket. Ah! I see! The cockles lie beneath the sand, embedded in it, at a depth of from half-an-inch to an inch-and-a-half. This is a British California, and these are the diggings. Neither gold, nor cockles, grow on hedges: both have to be worked for. We have brought our basket: the iron hoop shall be fairly divided. You take one half, and I the other. Now scrape away. Bravo; this beats the rake! That fellow loses many a nice one between his rake's teeth. The old ladies from Stiffkey prefer iron hoops to rakes. Another handful of cockles; and here, another! We shall fill the basket. This man only happens to be out cockleing because he has nothing better to do. The regular female professionals are not here to-day, because the carriers' carts (departing twice a week) have all left this morning; otherwise you would have seen a numerous coterie, with succinet drapery, mahogany legs, and incessant clack; still they have a discipline, and a fair-is-fair sort of feeling among themselves. They think this sport, in all possible weather, no hardship; nor grumble at carrying a bushel of cockles two or three miles. Shut them in their cottages, and keep them incessantly to the loom, or the needle, and they would soon pine and die, if they did not go mad.

There; we have filled the basket, a good peck-and-a-half, and have earned a shilling, at eight-pence the peck. The good folks here make three "culls" of their gathering, and

sell the best at three-pence a quarter. Ours are a beautiful sample, clean, not gritty, large, well-flavoured. A man from the next parish discovered this particular "digging" about three weeks ago, and made a fine harvest, till the Stiffkey folks found out his secret. But the tide is flowing, and will carry us up-channel. Time to be off: it is getting dusk, and coming on "roky." Those are not ships, as seen through the misty air, but ghosts of them. Darker and darker, and no moon. The keel of the boat scrapes against the oyster "lays," but does not stick, the tide bears us upwards and onwards so fast. There shines the light of a forge, to serve as a beacon. I wonder how Broadback can find the way, amidst those intricate creeks and mud-banks. "And I," says Broadback, "wonder people are not afraid to travel by night through those lonesome roads, and lanes, and woods." And here we are at last at Blakeney: the day's excursion is ended. I feel a vacancy about the region of the stomach that will not be easily filled up. Afterwards, we will amuse ourselves by roasting cockles for dessert.

South of the Wash, the sandy dunes of Norfolk, called "Meals" and "Marram Banks," are the only places on the east coast of England where there is any chance of catching the sheldrake in the act of nesting; and that chance is yearly becoming less and less, solely from the intrusive curiosity of man. For in front remains the sea, and behind, at present, the salt-marshes; while the rabbits are as numerous as ever, to scoop out the required excavations. The sheldrake is no excavator, and yet it will have a cavern for its nursery. How it arranges matters with the rabbit, of whose house it takes possession, is not so easy to guess as in the case of the pufins, who are equally impertinent in other warrens. They have a bill that would furnish a sharp answer to any rabbit that undertook to remonstrate too obstinately at the mouth of his hole. The want of this underground retreat is one reason why sheldrakes so rarely breed in confinement. They have been successfully tempted by artificial burrows near the water's edge; and a hollow tree let into the bank, forming a sort of blind tunnel, or choked-up drain, has proved irresistible. The darkness seems to be one of the conditions which pleases them; for a tame pair, not being able to find any subterranean hiding-place for their eggs, deposited them under the thickest obscurity of some clipped yews. By attending to these natural requirements; by now and then giving the old birds a treat of small cockles, mussels, and periwinkles; and by letting their young have a daily ration of fresh sea-fish chopped fine; it may be expected that this very striking bird will be reared more frequently than it now is, in the tiny lakes which give so pleasing a charm to our lawns and our shrubberies.

D.

TO CORRESPONDENTS.

VINES (*Omega*).—We are not aware of any work which treats specially of vines in pots. Before answering your questions safely, it will be necessary to know the age of your plants, the diameter of the shoots in their thickest part, and the size of the pot they are in. This obtained, we will give a satisfactory answer.

APRICOT AND QUINCE (*H. M., Herts.*).—Your *Breda Apricot* is not an uncommon case. We had one as large as an apple-tree, which stood for fifteen years without producing a crop—indeed, it seldom set any; but it was too far north (Cheshire). Hertfordshire should produce one. Your "not very free exposure" means partial shade, and this will not do. We would remove it to where it gets every hour's sunshine, and plant it on the ground level, with only a foot of soil beneath it, and that plain loam; no manure. It must not grow strong; and succulent wood should be pinched in from June and July. You may prune away all the coarse young wood on removal. The only one we ever saw cultivated with high success as a tree, was, like yours, at Hampton Court, at the Royal gardens. Thirty-five years since, we have seen this tree laden with fine fruit, and once partook of a tart from the produce; this was excellent. Your Quince that is mildewed, and has ceased to bear, must have a thinning, and receive the sulphur mixture when at rest; also top-dress with old vegetable matter. The Quince is very liable to this mildew. Prune your nuts heavily, and root-prune them.

ERRATUM.—Page 28, line 36, for *monstrous* read *monotonous*.

SEVEN HARDY CLIMBERS FOR GREENHOUSE, AND CONTRASTING IN COLOUR (*N. S. E.*).—*Passiflora racemosa*, purplish; *Bignonia capensis*, yellow; *Passiflora corulea*, blue; *Kennedia Marryatta*, scarlet; *Mandevilla suaveolens*, white; *Tacsonia pinnatifidula*, rose; *Bignonia cherere*, reddish-dull-orange. These will do planted outside of the house, but the roots and stems (as much as is outside) must be protected, the former with litter, the latter with square boxes set against the front wall, filled with sawdust, and capped from wet. They will succeed also in pots or boxes inside the house, but they will grow more rampant in the border.

TWO PLANTS FOR THE BACK WALL OF A GREENHOUSE (*Ibid.*).—You have not said for what purpose. If merely to keep green, try *Cissus*

pentaphylla, and *C. elongata*; if light would reach the wall sufficiently, train *Acacia armata* in one division, and *A. grandis* in the other; or make half *Cactus speciosissimus*, and the other *speciosus*, but they must be dry in winter.

ERICA BICOLOR (M. A. B.).—This produces colourless flowers, and yet the plant is healthy, and well treated. We cannot say what is the cause; perhaps the plant is rather vigorous. Restrain water, just to keep it safe, and see what that will do. We have seen a similar effect produced by water from a pond, in which there was a considerable proportion of decomposing vegetable and animal matter. Use rain water, if possible.

GOLDING'S IMPROVED HIVE (C. W.).—I generally use a bung of cork (when I can procure any so large) for the top holes to all my hives, whether of wood or straw; but there is no need to despise a bit of slate or wood, or anything that may come first to hand suitable for the purpose of covering the holes effectually. I never ventilate my hives in winter, but think it better to keep the bees as snug as possible. My large Golding's hives (of one bushel, corn measure, for permanent stocks) are quite large enough to keep up a supply of as much pure air as the bees can require.

—A COUNTRY CURATE.

AGE OF YOUNG BEE BROOD (Mary).—If your correspondent can procure a copy of the second edition of "The Honey Bee," by Dr. Bevan, she will, at page 398, find a plate exhibiting a piece of honey-comb, and giving very accurate representations of young worker bees of every age, from the first hatching of the eggs at three days old, to the ceiling up of the cell. The eggs are long, whitish, thread-like, or worm-like objects, and when once seen cannot be mistaken. It is not good to use old brood-comb, the bees find it difficult to work up into royal cells. The newer the comb the better. I always get pieces of fresh comb, containing both eggs and brood.—A COUNTRY CURATE.

SOIL FOR ROSES (Subscriber).—The nearest idea we can give you of the right soil for Roses of the *Noisette*, *Bourbon*, and *Hybrid perpetuelle* classes, is this: The same soil that will grow the best onions is the best for these Roses; that soil ought to be manured for Roses, as for onions, with the best rotten manure. Any garden "man," or any "odd" man near you, could tell from this if your soil is suitable. Twenty inches or two feet would be better than less depth if the bottom is dry or drained. If it is not, and is sour and wet, a foot deep is quite enough. For the *Tea-scented Roses*, we would use as much fresh light loam as we could get, chopping up the turf with it, and to every four barrow-loads of it add one barrow-load of half-dry rotten dung. We would mix all this before filling the bed, which is a better way than digging in the dung. No one can tell the actual strength of *liquid-manure*. Use it weak and often is the only safe rule. It is weak when it will not kill grass or dock leaves, or any rough weeds, and after mixing a lot, one can always prove it that way.

FLOWER-GARDEN PLAN (Michel).—Some day or other we may engrave your plan, on account of the novelty of the design. The colours are put in beautifully and artistically, but the plan is all but impracticable. There are seven colours given in each of the end groups, four of which are collected together in one sharp point, a thing that can never be done in practice. The *Marigold* and *Anagallis* will never associate for one side, nor be in proper character with the fine shades of *Verbena* on the opposite sides if they did. The gradations of heights in plants must be as much considered as the colours in a regular figure. A plan or garden that admits of all the plants being of the same height is less dignified than one in which different heights can be arranged with good effect; the latter is by far the most difficult to design.

GERANIUM CUTTINGS (British Seaman).—From your log, we say positively that you will not be wrecked, but the cargo will not come all safe to port. You weighed anchor too late in the season for this. Keep cutting away all leaves that droop, and pick off every black speck as soon as perceived; be sparing of the watering-pot, and raise the temperature just ten degrees. Geranium cuttings made very late in the autumn (October) would be safer on a shelf, high up in the greenhouse, than in a hot-pit of 50° an hour after breakfast. We put in nearly as many pots of cuttings as you (100), late in October, and put them on a very dry shelf, under glass, up high above pots and kettles, with a free current of air, and we expect about seven or eight out of every ten of the cuttings to live; and if they are rooted by the middle or end of February, it is all that we expect and wish for. Hotbeds are awful places for unstruck cuttings in November. *Wood lice* do little or no harm to Geranium cuttings in winter. A selection of bedding Geraniums will be given before you can want them.

CARNATION AND PICOTEE SOIL (G. W. C.).—You say your soil in which you have hitherto grown Carnations, Picotees, and Pinks, is light, and rather inclined to be sandy, and that you have purchased them at times, but have nearly all died. Your soil is too light, and there should be no sand in it. Procure some virgin loam, make your bed of it, with the addition of about one-eighth very well-decomposed hotbed manure. Plant the Pinks now, and the Carnations and Picotees in spring, about the end of March, and attend to the instruction in the Monthly Calendar. Are you quite sure you have no wire-worms in your soil? They are very destructive to these plants. We never recommend dealers.

ARNOLD'S VICTORY GERANIUM (An Amateur).—This was a mistake; it should have been *Arnold's Virgin Queen*.

ROSES (Zadkiel).—You, or a namesake, used to predict the weather, and we predict, that if this should be a very hard winter you will lose nine out of ten of your newly-budded roses that had grown an inch by the middle of October. You must not ask for our sympathy, for you have rushed against a cross firing on the subject of budding roses this very season; but the loss will not be lost on you. When you had next year you will attend to our directions, and not cut back, or even stop, any of the shoots at the time of budding.

CUCUMBERS (Ibid).—Go on and prosper with your new house, the symptoms could hardly be better: house at 80°, soil at 90°, with fine, damp atmosphere; plants looking healthy, and fruit twelve inches long, and growing. What could Mr. Latter himself want more than that? If you find the edges of a single leaf damping from this moist atmosphere, give more air, and throw something on the glass at night, and that will lessen the drips.

TOM THUMB (A. S., 16th Oct.).—Out of all your letter we can only read "Tom Thumb," and "No. 1, 2, and 3." Pray write to us plainly.

SALVIA PATENS (X. Z.).—If you do not want the pots this winter, you had better leave the roots in them, and if you put them in an outside they will dry slowly, without any more trouble. They will also stand exactly the same treatment as potatoes in winter. You might pit them, or house them, or keep them a little moist, or nearly dry. The surest way to get rid of the worms is to turn out the balls gently on the palm of the left hand, and hand-pick them from the balls. Do not, on any account, resort to the common nostrums for poisoning them in the pots.

WINTERING GERANIUMS (Shylock).—If you will refer to page 53 of our last number you will find a mode exactly suitable to your case.

CINERARIA SOWING (B-le-B).—Sow the seed as soon after it is ripe as you can.

HOLLYHOCKS (T. J. C.).—We cannot put in such a proposition.

COW DISEASED (G. T. H.).—The case is too critical for us to advise you. You had better consult some regularly educated veterinary surgeon. What your man says is nonsense.

FUNGUSES (H. L.).—We believe those you sent are poisonous. They are too dangerous to try experiments with.

VULCANISED INDIAN-RUBBER.—J. M. wishes to be informed how he can make a cement that will fix Vulcanised Indian-rubber to wood, glass, or leather.

FORGET-ME-NOT.—If *Ellen*, or any other of our subscribers, will forward their address, with two postage stamps, to *F. Brett, Esq., Potter's Bar, near Barnet*, he will send them a root of this free by post.

OUR VOLUMES (T. G., Dominica).—Our first volume commenced with the first Thursday of the October of 1848, and concluded on the last Thursday in the March of 1849. Our second volume commenced on the first Thursday of April 1849, and ended with the last Thursday in the September of that year. So have the volumes continued to divide the year ever since. You can have indexes for each two volumes that so comprise twelvemonths.

POLAND FOWLS AT DOMINICA (Ibid).—Our correspondent says he thinks he is the first person to introduce these fowls into the West Indies. They were shortly attacked with what he considered a severe cold, affecting chiefly their eyes, and partially blinding some of them, but the birds have bred, and we hope to hear from him how the chickens prosper. The disease was not a cold, but the roup, an inflammation of the head and eyes, caused by the confinement, filth, bad feeding, bad water, and exposure to weather on board ship. A daily pill the size of a pea, made of two parts powdered gentian and one part hydriodate of potash, is the best medicine. Good food and cleanliness are essential additions.

POTATO PLANTING (R. K.).—On the Cotswold Hills, and in a soil and exposure favourable to potato culture, we would still plant no later varieties than *Hoptown Earlies*, *Ash-leaved Kidneys*, and *Rylott's Flour-balls*. Keep your sets as free from sprouting as possible, until you wish to plant them.

BACK NUMBERS (Alpha, Birmingham).—None are now out of print. All have been reprinted.

WHAT IS A PURE BREED OF FOWLS? (Investigator).—This is a question not so difficult to answer as it may appear. Our correspondent asks, "Whether a cross between pure-bred Dorkings and a Game cock would revert to the original type of Dorking in two generations? That is to say, would the cross between Dorking and Game, bred again with pure Dorking, produce fowls which could be called true Dorkings?" We think they would, otherwise one of the most efficient modes of improving our breeds of domesticated animals would be closed. How common is it to infuse courage and substance into our breed of Pointers by a cross with the Hound; and how equally common to derive fineness of bone, depth of carcase, and other desirable points, by an intermixture of our breeds of oxen. Yet the calf of a Short-horn cow, if it retained all the characteristic points of its variety, would be classed as a Short-horn, without any reference to the bull that was its grand-sire.

NAMES OF PLANTS (Rev. R. M. E.).—Your annual is *Coreopsis Drummondii*, in *The Cottage Gardeners' Dictionary*, but also known as a *Calliopsis*. (*Hester S.*)—The Conifer is not Cedar of Lebanon, but the Hemlock Spruce Fir, *Abies Canadensis*. Nothing certain is known about the *Hamony*. We will say more about it, however, soon. (*T. F. J.*)—Your annual is the *Centurea cyanus*, varied a little in colour; the second is not a *Lycopod*, but *Saxifraga elongata*, or Long-stalked Saxifrage. We do not recognise the orchid from the leaves, but will enquire. (*B. H.*)—1. *Cineraria umelloides*. 2. *Statice mucronata*. 3. Too small a specimen. 4. *Sedum Sieboldii*.

CALENDAR FOR NOVEMBER.

FLOWER GARDEN.

ANEMONES, plant for succession bloom. **AURICULAS** and **POLYANTHUSES**, put under shelter (See October). **BULBOUS ROOTS**, finish planting in dry weather; or pot for latest forcing, and for plunging in flower-beds, &c. **CARNATION** layers, finish planting and potting; secure the pot at once from rains. **CLIMBERS** of all sorts, plant, prune, and train. **COMPOST**, prepare and turn in dry weather. **CROCUS**, pot large lumps from the borders for forcing. **CHRYSANTHEMUMS**, against walls or fences, secure from frost. **HALF-HARDY** bulbs in borders, secure from frost and rain by a boarded covering. **DAHLIAS**, cut down after frost, and let roots remain as long as it is safe; when taken up, dry them in open sheds, &c., before storing, where frost and damp cannot reach them. **DRESS** the beds and borders, and put mark-sticks to bulbs and other roots, to guide you when digging. **EDGINGS**, plant. **EVERGREENS**, finish planting, b. **FIBROUS-ROOTED PLANTS**, finish dividing and planting, b. **FORK** over borders, &c. **GLADIOLUS**: all the old sorts may yet be planted; most of the new do better planted in spring. **GRASS**, cut very close the last time; keep clear of leaves; and roll. **GRAVEL**, weed and roll. **HEDGES**, plant, clip, and clear at bottom. **HOE** and rake shrubberies, and bury the leaves, &c. between the plants. **HOLLYHOCKS**, finish planting. **LAYERING**, perform at intervals, if fine weather, till March. **LEAVES**, gather for compost, &c. **MARVEL OF PERU**, take up and store like dahlias. **MULCH** round trees and shrubs lately planted. **PLANT** perennials and biennials (See October). **PLANTING**, deciduous shrubs and trees, perform generally, and finish as early as

practicable. **POTTED PLANTS**, for forcing, plunge in the earth of a well-sheltered border facing the sun. **PRUNE** shrubs and trees generally. **RANUNCULUSES**, plant for earliest bloom. Seedlings of them, in boxes, &c., remove to a warm situation. **WEAK ROSES**, prune without delay; very strong ones, delay pruning till March; tender ones, secure from frost with moss, fern, &c. **SHRUBS** of all kinds, plant, stake, and mulch. **SUCKERS**, from roses and other shrubs, separate and plant. **TIGRIDIAS**, save from frost as long as possible; should not be dried till January or February. **TULIPS**, finish planting, b. D. BEATON.

GREENHOUSE.

AIR, admit rather freely in dry weather. **AZALEAS**, for blooming early, keep in the warmest end of the house, and they will not lose many of their leaves; if the buds are well set and prominent, a few may receive the heat of a plant stove, to bring them in by Christmas; those once forced will come earlier of their own accord again. Those for flowering in spring and early summer keep as cool as possible, so that the temperature is above 35°. **BULBS**, such as hyacinths, tulips, narcissus, &c., pot for spring flowering, and so manage them that roots shall precede flower-stems. **CALCEOLARIAS**, keep growing slowly, in an airy, moist atmosphere; seedlings, pot off, and prick into pans; cuttings of shrubby ones may now be potted, and cuttings may even be put in in the beginning of the month, in a cool, moist place. **CAMELLIAS**, finish setting in; and the late ones may have their buds thinned, if necessary; the earliest will now be swelling, and a little cow-dung water, cleared, and not too strong, will do them good; these should be placed with the forward azaleas. **CINERARIAS**, encourage the forwardest to grow in a moist, gentle heat; keep those for spring and summer just moving. **CLIMBERS**, however beautiful, cut back to give light to the other plants. **CHRYSANTHEMUMS**, remove incipient roots from the axils of the leaves on the main shoots; thin the buds where too thick; encourage with manure water; and if not all in doors, have protection ready. **DAMP STAGNANT AIR**, avoid. **FIRES**, light in frosty and foggy weather, that air may be given; but give artificial heat during the day, rather than at night, unless the frost is very severe. Choose a sunny day, if possible, to light your first fire, as your flue, &c., will be more easily dried: it is no joke to be fixed in a stock-hole behind a fire that will not burn. **FURNACES** and **FLUES**, clean out previously. **HEATHS** and **EPACRISSES**, keep in the airiest part, especially the former. **GRNISTAS**, **CYTISUSES**, **CORONILLAS**, &c., syringe in a sunny day, and aid with manure water, to cause the bloom to open strongly. **GERANIUMS** or **PELARGONIUMS**, encourage the old plants with a good position; train into the desired shape. Nip any luxuriant shoot, so as to equalise the strength; keep fresh potted ones just moving. **GOMPHOLOBIUMS**, *Platylobium*, *Chorozenus*, &c., place in double pots, that they may be more uniform in moisture, as extreme dryness and extreme wet will alike be their ruin. **PLANTS**, keep clear from dirt and insects, by washing and fumigation. **TEMPERATURE**, keep from 40° to 45° at night. **WATER** only when necessary in dull weather; little will be wanted, unless for plants swelling their flower-buds; for these use water warmer than the air of the house. A slight dusting with the syringe over the foliage will be serviceable in a sunny morning. **CLEAN** pots, paths, stages; tie, train, and fresh label in bad weather.

R. FISH.

FRUIT-FORCING.

CHERRIES in tubs, &c., protect roots. **CAPSICUMS**, dry off at root to ripen them. **CUCUMBERS**, afford necessary heat, not below 70°, with air-moisture and all possible light. Early forcing prepare for. **FIGS** for forcing, get to rest; protect pots or boxes, as also branches. **FLUES**, clean all and repair. **INSECTS**, continue the warfare against, also preventive measures. **MUSHROOM-BEDS**, provide succession; spawn when down to 75°; sprinkle beds where the Mushrooms are coming through; keep a moist air. **MELONS**, sustain 75° bottom-heat, 70° top-heat, with abundance of air; fumigate if infected. **NECTARINES** and **PEACHES**, prepare for early forcing, by using the wash so often named in this work, pruning them previously. **PINES**, in dung-pits, improve declining heats; 60° to 70°, with liberal ventilation. **Pines**, late fruiters, 5° more; air in moderation. **REPAIRS**, carry out directly in all houses. **REST** fruits for forcing, plunge and protect wood. **STRAWBERRIES**, in pots, plunge and protect. **VENTILATION**, attend well to during dull periods. **VINES**, for early forcing, as *Peaches*; if roots outside, protect border directly. **Vines**, in fruit, fire occasionally; ventilate freely; keep very dry, and use scissors weekly.

R. ERRINGTON.

ORCHARD.

BORDERS, autumn-dress. **BUDS**, cut bandages off. **CHESNUTS**, gather. **DRESS** to KILL INSECTS as soon as pruned. **FRUIT**, gather all remaining. **FRUIT-TREES** of all kinds plant. **FRUIT-ROOMS**, ventilate freely. **FRUIT-STORES**, pick over. **INSECTS**, wage war against, at every opportunity. **MEDLARS**, preserve. **MULCH**, apply to newly-planted trees. **NUTS**, remove suckers from. **NAILING**, proceed with, in order to expedite spring business. **PRUNING**, perform in the following order: 1st. Bush-fruit, then Cherries, Apples, Plums, Peaches, Vines, &c., and ordinary Pears, reserving choice ones, Apricots, Figs, &c., until spring. **PROTECTION** for blossom, lay by from shrubbery or wood prunings. **PLANTING**, proceed with, all but Figs and Vines. **RASPBERRIES**, plant suckers from, and prune. **ROOT-PRUNING**, perform immediately. **STAKING**, see to. **STRAWBERRIES**, remove rubbish between rows, and manure, but cut not the foliage. **STATIONS**, prepare. **TRAINING**, carry out betimes. **TOMATOES**, ripen before the fire. **TOP-DRESSINGS**, apply. **WALKS**, turn or clean for the winter. **WEATHER**, provide in-door's work for a bad season, such as labels, stakes, training pegs, &c., and grind your bill-hooks, and file your hand-saws.

R. ERRINGTON.

ORCHID HOUSE.

AIR will seldom be required during this month; keep the air inside much cooler, because most of the plants ought now to be in a state of rest. **BASKETS**, plants in, should only be syringed; they ought to be so placed that the drip from them may fall into the walk. **DIVISION**: such plants as *Stanhopeas*, *Gongoras*, and *Acropcia*, may be divided this month, with a view to increase them; give these no water till they start into growth again. **HEAT**: the thermometer in the warmer house should be allowed to fall to 58° in the night, and never exceed 70° by day; 65°

without sun will be sufficient. **POTTING** will be required occasionally; even at this untoward season of the year some plants will grow, and, therefore, must be potted, because if delayed the young roots will begin to push, and then it is difficult to pot without breaking them. **REST**: keep all the plants possible at rest for the next two months; the means are a cooler and drier atmosphere, and no more water at the root than is absolutely necessary to prevent the pseudo-bulbs perishing. **SYRINGING** will be necessary to plants on blocks two or three times during the month. **WATER**, apply sparingly, except to plants growing; to these a larger quantity may be given. T. APFLEBY.

PLANT STOVE.

AIR will still be necessary to this department; give it early in the forenoon, and close the opening by two o'clock. To sweeten the air, light the fires early in the morning, and give air accordingly; this will allow a large body of fresh air to enter the house, which will displace as much foul air. **CUTTINGS** of stove plants should all be potted off early this month if rooted. **BULBS** should now generally be at rest; keep them dry and moderately cool, to prevent a too early excitement. **FORCING-FLOWERS** for this department should be commenced slowly, early in the month, such as *Azaleas*, *Lilacs*, *Laburnums*, *Rhododendrons*, *Roses*, &c. These will flower in December or January. **WINTER-FLOWERING PLANTS** will now be showing their flowers. They should have a moderate supply of water, and occasionally a watering with weak liquid-manure. Keep every part of the stove perfectly sweet and clean; remove all decaying leaves as they occur; stir up the surface of the soil in the pots, to prevent moss and weeds from appearing. In this month, a supply of the different soils, manures, and vegetable mould, should be procured. T. APFLEBY.

FLORISTS' FLOWERS.

ANEMONES may yet be planted, excepting the finest double ones. **AURICULAS** and **POLYANTHUSES**; no delay must take place in putting these into winter quarters, if not already done. Scatter occasionally amongst the pots a layer of very dry ashes, which will absorb the moisture. **CARNATIONS** and **PICOTEES**, finish taking off the layers, and potting them; place them in cold frames, giving plenty of air every day. **DAHLIAS**, cut down when frost-bitten, and cover the roots with a small billock of coal-ashes, or take them up at once, and reverse the roots, to allow the moisture to run out of the hollow stem. Number every root, and put them by in a dry, cool place, where no frost can reach them. **FUCSIAS**, done blooming, prune in, and give no water to, for a month. **HYACINTHS**, finish planting, both in pots and beds. **IRISES**, both *Spanish* and *English*, plant in a rich soil and open situation. **NARCISSUS**, pot and plant out in the beds. **PINKS**, plant out early; fasten firmly, to prevent the frosts from drawing them out. **RANUNCULUS-BEDS** prepare. *Turban variety* plant in beds and pots, the fine-named varieties do not plant till spring. **TULIPS**, plant on or about the 10th of the month; choose a dry day for doing this. **VERBENAS**, take up and pot, dressing-off the straggling branches; their cuttings shelter from early frost. All **FLORISTS' FLOWERS** in **FRAMES** and **PITS** keep moderately dry, clear of weeds, and decaying leaves. Search for **SLUGS** and other vermin daily. T. APFLEBY.

KITCHEN-GARDEN.

ARTICHOKES, winter dress. **ASPARAGUS-BEDS**, dress; attend to that in forcing, and plant in succession. **BEANS**, plant a good main crop toward the end of the month. **BEEF** (Red), dig up for storing. **BROCOLI**, lay down or remove to other warmer situations with good balls of earth; take care not to injure their leaves. **CABBAGES**, plant or prick out into nursery-beds. **CARDOONS**, earth up, b. **CARROTS**, dig up and store, b.; leave or plant out for seed. **CAULIFLOWERS**, prick out in frames, &c., for winter protection, pay particular attention to airing in all fine weather, both hand-glass crops and otherwise. **CELEBY**, earth-up in dry afternoons, having the earth all forked up previously. **COLE-WORTS**, plant. **COMPOSTS**, prepare, and always have a supply in the dry for immediate use. **CUCUMBERS**, attend to in forcing. **DRAINING**, attend to where required. **DUNG**, prepare for hotbeds. **EARTHING-UP**, attend to. **ENDIVE**, tie up for blanching or otherwise; pay particular attention to protection. **GARLIC**, plant. **HERBARY**, clean, &c. **HORING**, attend to; on a fine afternoon never lose a favourable opportunity for this or any other kind of work. **HORSERADISH**, dig up, and lay in the prime for use, and replant. **HOTBEDS**, make for salading, &c. **JERUSALEM ARTICHOKEs**, dig up and store. **LEAVES**, continually collect into some corner for future use. **LETTUCES**, plant in frames; attend to those advancing. **MINT**, plant; force in hotbed. **MUSHROOM-BEDS**, make; attend to those in production. **ONIONS**, in store, look over; (Potato), plant. **PARSLEY**, plant some in a frame for use in snowy weather. **PARSNIPS**, dig up and store, b.; leave or plant out for seed. **PEAS**, of the best early kinds, may be sown toward the middle or end of the month. **POTATOES**, attend to those in store, or dig up, should any remain out. **RHUBARB**, clear away decayed leaves, and top dress; also pot off any number of plants that may be required for early forcing, to bring into the forcing structure as wanted. **RADISHES**, sow, in hotbed. **SALSAFY**, dig up and store. **SCORZONERA**, dig up and store. **SEA-KALE**, pay particular attention to the removing of all the decayed leaves, &c.; top-dressing, covering up with fermenting materials, or other modes of forcing. **SEEDS**, dress and store. **SHALLOTS**, plant, b. **SMALL SALAD-ING**, sow; sow in hotbed. **SPINACH**, thin, earth-stir, and keep clear of decayed and fallen leaves. **THINNING**, attend to. **TRENCH**, ridge, &c., vacant ground. **TURNIPS**, attend to thinning-out, or hoeing the late sown crops, and should the weather be inclined to set in very severe, any number of turnips that are full grown may be taken up, and stored for winter use. Spading-in is often better than the hoe. Always **COVER-UP** a little earlier on the appearance of frosty nights. Also look over your **BROCOLI** quarters of a frosty-looking evening. See if any are fit to cut, or if their leaves need to be broken down over the heads as a protection. T. WEAVER.

WEEKLY CALENDAR.

M D	W D	NOVEMBER 4-10, 1852.	WEATHER NEAR LONDON IN 1851.				Sun Rises.	Sun Sets.	Moon R. & S.	Moon's Age.	Clock aft. Sun.	Day of Year.
			Barometer.	Thermo.	Wind.	Rain in In.						
4	TH	Laburnum leafless.	30.002—29.762	40—22	N.	02	1 a. 7	26 a. 4	10 13	22	16 17	309
5	F	GUNPOWDER PLOT, 1605.	30.084—29.884	45—37	W.	02	3	24	11 28	☾	16 15	310
6	S	Cherry leafless.	29.870—29.846	47—38	N.W.	—	5	22	morn.	24	16 12	311
7	SUN	22 SUNDAY AFTER TRINITY.	29.835—29.770	47—35	N.E.	—	7	21	0 48	25	16 9	312
8	M	Lombardy Poplar leafless.	29.874—29.835	48—38	N.E.	07	9	19	2 10	26	16 4	313
9	TU	PRINCE OF WALES BORN, 1841.	29.869—29.803	43—39	S.E.	14	11	17	3 35	27	15 59	314
10	W		29.757—29.626	49—28	N.E.	01	12	16	5 1	28	15 53	315

METEOROLOGY OF THE WEEK.—At Chiswick, from observations during the last twenty-five years, the average highest and lowest temperatures of these days are 51.8° and 37.6° respectively. The greatest heat, 63°, occurred on the 6th in 1834; and the lowest cold, 20°, on the 3rd in 1845. During the period 91 days were fine, and on 84 rain fell.

LONG TUBED-FLOWERED OXYANTH.

(*Oxyanthus tubiflorus*.)



THIS is a handsome stove evergreen shrub, about three feet high, from Sierra Leone, having white starry, fragrant flowers, with long tubes, as expressed by its names, *Oxyanthus* being derived from *oxys*, sharp, and *anthus*, a flower, referring to the sharp-pointed or starry divisions of both the flower and flower-cup, *alias* calyx. It is figured in *Andrews's Botanical Reports* as *Gardenia tubiflora*.* The genus consists of plants having flowers more or less tubular, but there is a marked difference in the extraordinary length of the tube in the present species, which justifies the application of the specific name, *tubiflorus*. The genus was founded, some years since, by De Candolle. The present species was received by the Earl of Derby direct from Sierra Leone, and was sent by him to Kew, where it flowered for the first time in the July of 1851. It had previously been cultivated at Kew, but erroneously, as the *O. speciosus* of De Candolle. *Leaves* unequal sided, opposite, about four inches long, pointed-reversed-egg-shaped, smooth, almost stalkless; *flowers* in a single cluster, on very short stalks, from between a leaf and the branch; *corolla* greenish-white, six inches long; *stamens* at the mouth of the tube; *stigma* projecting out of the tube. It belongs to Pentandria Monogynia of Linnæus.

The genus belongs to a section of the Cinchonads, which is named in Latin after *Gardenia*, and may be translated *Gardeniads*. Its nearest relationship is with *Posoqueria*, but

* It is *O. tubiflorus* in *Botanical Magazine*, t. 4636.

is not far removed from *Gardenia*, and *Randia*. Formerly, and even at the present day, the plants included in this extensive order are called Madderworts (*Rubiaceæ*), by some able botanists. The natural differences between the true Cinchonads and the real Madderworts are so obvious, however, that the young gardener can point them out at first sight. All the Madders have square stalks, and the leaves are in whorls round the stalk, without any stipules. The Cinchonads, on the other hand, have not a single plant among them with a square stalk, out of the 2,500 species enumerated as such, nor one having the leaves produced in whorls, and every one of them have stipules; the stipules themselves being placed differently in Cinchonads from all other plants, that is not immediately under the foot-stalk of the leaf, but intermediate between one pair of leaves, and the next pair; or, as botanists say, interpetiolarly. Almost all the Madders are as mere weeds to gardeners, while the great majority of Cinchonads are among his best stove plants, as *Ixora*, *Bouvardia*, *Gardenia*, *Rondeletia*, *Hindsia*, *Pentas*, *Manettia*, and many more such. B. J.

Propagation and Culture.—All the best flowering plants in this large order are natives of countries lying within the tropics, and, therefore, require stove heat in this country, and of them it may be said, more than of other tribes, that, as long as they are in the nursing state, the temperature of a close pit, with a brisk bottom-heat, derived from stable-dung, or the old hotbed system is more necessary for them, and more congenial to their nature; and also, that while in this progressive state, they require more peat in the compost than most woody stove plants. With these general rules before the propagator, he takes cuttings of *Oxyanthus tubiflorus*, from the tops of the side-shoots, early in March; plants them close to the sides of a small pot filled with a compost of one-half peat and one-half sand, with an inch of silver sand on the top; and when the pot has had time to drain, after a liberal watering, he places it within another pot, one size larger, filling the space between the two pots with any light compost, finishing with a little sand on the top, to receive his bell glass, which must rest about half way between the two pots. If all goes on as it should, he expects to see his cuttings rooted in six weeks, but a week or two, more or less, will not damp his ardour, if his cuttings do not damp off meanwhile, and to save them from that, he takes off the glass occasionally, wipes it dry, and sees that the sand is neither too wet, nor over dry about the cuttings. At other times, he merely waters the outside of the bell-glass, which will trickle down in the outside pot, and so keep the inner pot and the cuttings sufficiently damp to insure safety, and the emission of roots. When the cuttings are well rooted, he shakes them gently out of the pot, and using two-thirds peat, and one-third sand, he pots them singly into little pots, but instead of placing his little plants in the middle of the pot, old-blue-apron like, he puts each of them in quite close to the side of the pot, and this allows more space for the tender roots, and they will not be so likely to get broken. After a gentle watering with warm water, he plunges the pot again in the hotbed, and puts a small hand-glass over them to insure a speedy growth. A few days after this, he tilts the hand-light on one side, to inure his nurslings to the air by degrees. In a few more days the hand-light is left off at night, and put on after breakfast time, and the first cloudy day he leaves the hand-glass off altogether. A son born to an Empire

could not be more tended to than they are all this time; but it is not more than is necessary, for the nursery is the proper place to lay the foundation of future prosperity, both for plant and heir. As soon as the little pots are filled with roots, then comes another shift, and this is the right time to put the plant in the right place—the centre of the pot—which is a simple move, only to place the ball more to one side of the new pot. The compost is a little stronger, and more stimulating this time; one-third peat, one-third sandy loam, and the other third made of sand and leaf mould.

If all this has been got through by Midsummer, the plants may require another shift before the end of July, but it is always more safe for seedlings, and for young

plants got from cuttings, to begin the autumn with them a month earlier, without a shift at the end of July, than to face the winter with them in pots not well filled with roots and wood in an unripe condition. Therefore, on the whole, let gardeners risk as they may—if they kill two to save one plant, who cares—but let the amateur take my advice, and be content with less growth the first season, and more security for the next. After the first year, our *Oxyanthus* will rank with a general assortment of young promising stuff, requiring about one-third peat, and two-thirds good friable loam, a few charcoal bits, and a little sand, also weak liquid-manure, now and then, and frame-culture, with stopping of shoots, so as to bring up a sure foundation for the future specimen.

D. BEATON.

HOWEVER much some of our correspondents may object to our advocacy of the Potato as a main crop, we must still pursue our course; and we are firm in our resolve to persevere, for many reasons, of which one or two of the most prominent will, perhaps, be accepted as a sufficient justification.

In the first place, the declaration of one gentleman, with whom we conversed the other day, bears testimony to a fact of far greater importance than the words, at first, may seem to convey:—"I do not care for my dinner," he said, "unless potatoes are part of it." It is not an exaggeration to say, that to three-fourths of the population of our islands this vegetable is similarly acceptable. Nor is it a mere consideration as to whether this or that plant affords a food most agreeable to the palate, though even that is important; but the fact is notorious, that, by the best of management, you cannot grow of any other crop so large an amount of nutriment upon an equal space of ground.

The Potato being so generally acceptable to the palate, and being so very productive, it has become, as a matter of course, a crop of most extensive cultivation. The amount of this cultivation has been endeavoured to be ascertained in various ways, and the following are some of the facts ascertained:—

In 1847, Parliament obtained from three unions, selected as fair average examples, returns of the amount of acres devoted to the culture of the various usual crops. In *England*, out of the 21,756 acres in Hartley Witney and Basingstoke union, 236 acres were occupied by Potatoes. In *Scotland*, in the county of Edinburgh, or Midlothian, of 176,874 acres, 6,625 were growing the same root; and in *Ireland*, in the Balieborough union, comprising 86,324 acres, the Potato occupied 11,492. If these, added together, are a fair average of the United Kingdom, then more than one-fifteenth of its surface is occupied by the Potato.

In the same year, Parliament obtained from the constabulary of *Ireland* a further return of the total of its acres then under Potatoes, and the returns showed a gross amount of 284,116 acres, producing 2,048,195 tons of their tubers. In *Scotland*, Mr. McCulloch calculates there are annually grown 200,000 acres of the same root; and he combines Potatoes, Turnips, and Rape, as occupying annually, in *England*, 2,000,000 acres, and their produce as worth, on an average, £14,000,000 sterling. We might multiply the statistical details to a much greater extent, but we will only add,

to show what is the consumption in London alone, that in the three months preceding the first week of December, there are, on an average, delivered there, from ships only, somewhere about 300,000 sacks, each sack containing one hundred-weight-and-a-half of Potatoes.

Now this is the crop, and for which no adequate substitute has been suggested, which we have been advised to abandon as hopelessly diseased. We deny this being its state, and a very few weeks ago we showed why we are of this opinion. We showed that the disease is not universal—that even one field bears a healthy crop, whilst another, with but a hedge between, produces a crop diseased; and that it is quite as frequent that one portion of the same field shall be exempt from the disease infecting the other portion. This being so, and these exemptions showing, as clearly as evidence can show, that there is a certain combination of circumstances which will secure a healthy crop, let us persevere hopefully in our endeavours to ascertain those circumstances.

In confirmation of the soundness of our view of the case, we have now before us two letters, which give practical proofs that there are varieties of the Potato not liable to the murrain that has scourged others; and that there are modes of culture which will ward off this murrain from a variety which is destroyed by that murrain, when differently treated.

The first letter is from Kintbury, near Hungerford, in Berkshire, from a very trustworthy authority, and it says:—"I want to draw public attention to a variety of the Potato called, hereabouts, the '*Kintbury Johns*,' and about Andover, the '*Foolhardys*.' It is a large, coarseish, prolific Potato, and does not boil floury; but it wonderfully avoids the blight, and has done so ever since the disease appeared. This year, which is considered the worst, it is remarkably free from the disease; and the gardener who has our garden says, that among his crops the *Kintbury Johns* have one gallon in a bushel tainted; while the *Fortyfollds*, and all other sorts, have three parts out of four bad. All the poorer people say the same thing. They do not plant it extensively, because they prefer other kinds for eating; but where other kinds will not keep, it seems to me that an inferior Potato is worth having."

If reference be made to our seventh volume, p. 297, a communication, signed H. B., *South Petherton*, will be found relative to Potato-planting, from which this is extracted:—

"It is possible that my plan may have been tried. The

object is to save seed, and give more light and air to the plants. I plant on ridges, three feet wide, one row down the centre, choosing the finest Potatoes, and placing them thirty inches apart. I flat-hoe early, and when the stalks are nine or ten inches long, they are spread from the centre, forming a circle, and the earth is pulled by hand over the middle of the plant; this process is repeated whenever the earth cracks.

"I succeeded this last year in my garden in producing from a ridge fifteen feet by three feet, 72½ lbs. of Potatoes, from six planted whole in March last. The several weights were 15 lbs., 15 lbs., 12 lbs., 11¼ lbs., 9¾ lbs., 9 lbs. Each Potato a different sort. Of the first, the *Old Guernsey*, six tubers weighed more than 6 lbs., and of the second, a pink kidney, there were not more than forty Potatoes to make up the 15 lbs. All the Potatoes were particularly fine."

We hoped to have had this year the results of a still larger experiment tried by the same esteemed correspondent. He, however, is gone from this world of experiments to that of realities; and we have this letter in reply to our inquiries:—"I have looked particularly to the experiments of the Potatoes planted by my late brother, and am sorry that I am not able to furnish you with any proofs of success of his intended mode of cultivation. Owing to his illness and inability to attend personally to them his directions were not carried out. He had planted them, on a large scale, in the field on the plain, in rows three feet wide and two feet apart, in drills; but instead of being laid after the first hoeing, and the earth brought up to the centre, they were hoed up in ridges in the ordinary way; consequently no fresh roots formed as last year, and the produce was deficient in consequence. Still the crop was equal in weight to those planted in drills of twenty-two inches in width, and much finer in sample, being all fit for general purposes, whilst at least one-third on the narrow drills were small; and although it would appear to be a great waste of ground, yet, from the above statement, it proves that the wide drills and deep earthing are most desirable. I strongly recommend to all small occupiers to adopt the mode of cultivation tried by my brother last year, as I am convinced, from what I see by the crop this year, although not carried out according to his plan, that it will succeed. I would also notice that, in this same field of several acres in which many of the labourers had their winter crop, there was not one exception in which they were not diseased and rotten to that extent as to be scarcely worth the expense of taking up. *Whilst in the deep experimental drills I do not think there was one affected.*"

We will only observe upon this that the writer is a highly intelligent, practical farmer, and one of the most extensive holders in the county of Somerset.

FORSYTH MSS.

IF SIR JOHN SINCLAIR had achieved nothing more in the course of the fourscore-and-two years of his life than gathering together and publishing his *Code of Agriculture*, his *Code of Health*, and his *Statistical Account of Scotland*, he would have left sufficient monuments of his untiring industry; an industry the more praiseworthy, because unstimulated by necessity.

He was the third son of G. Sinclair, Esq., heritable sheriff of Caithness, and was born in that county, at Thurso Castle, in the May of 1754. Embracing the legal profession, he was admitted a member of the faculty of advocates in Scotland, immediately that he was out of his nonage, and was called to the bar in England, about seven years later, in 1782, having previously to this sat in Parliament for his native county and other places. Although thus enrolled among the makers and interpreters of our laws, neither of their occupations were his favoured employments; for his heart was given to the cultivation of the soil. *Flemish Agriculture*, *Merino Sheep*, *Oil as a Manure*, the culture and uses of the *Potato*, the origin of *Cattle Shows* and *Agricultural Meetings*, and *Shell Marl* as a manure for Turnips, by turns, were the subjects of his researches, and were descanted upon by his pen. Nor were other subjects, though not strictly agricultural, if connected with the industrial produce of his native country, without receiving their share of his attention. An instance of this is afforded by the following letter, dated from Whitehall, February 19th, 1793:—

SIR JOHN SINCLAIR TO MR. FORSYTH.

It has lately occurred to me, that some of the French emigrants, who are now in this country, might be employed in a manner that would not be disagreeable to them, and would be useful to this country, *in the culture of silk*; but, from all the enquiries I have been able to make, there is little prospect of any material progress being made for some time. A French gentleman, however (one of the emigrants), the Viscount de Bruges, being thoroughly conversant in the culture of silk, it is a pity not to have some experiments tried in that branch even this year. I have sent for the eggs of the silk worm to different countries, and I beg you will be so obliging as to inform me whether there are many mulberries in His Majesty's gardens at Kensington, or elsewhere, and how many trees of thirty years and upwards, either of the *Red* or *White Mulberry*, might be found in the neighbourhood of London, the leaves of which might be either purchased or obtained this season. I am told that they abound much in the neighbourhood of Hammersmith, &c. I have also heard that Her Majesty has tried some experiments in regard to the culture of silk, the success of which you may have heard of. I shall be glad to have the pleasure of hearing from you upon this subject.

COVENT GARDEN.

Those whose field of observation does not extend beyond the smoke and din of London have very peculiar notions as to what is going on in the great world outside. They hear of frosts, and blights, and mildews, but comprehend them not; and when other men tell of this crop failed, and that community suffering, they regard the intelligence with a dim, hazy, and indistinct perception that there is something wrong somewhere, but they cannot realize it, simply because they do not see it, and have not felt it themselves. When you tell such people that apples are a short crop, and potatoes are diseased, they point to Covent Garden, and ask if there is evidence of such to be found there. "Pooh, pooh! nonsense," says one, "I never saw finer potatoes in my life; the farmers always did grumble, and always will; they *must* have something to grumble about." We confess there is some allowance

to be made for such remarks coming from such quarters, for there is certainly never any appearance of scarcity in our markets; and we know frequent instances where country produce is poured into London, and sold to be transmitted to the country again.

We have been led to make these remarks, that our readers may understand how it is we always speak of a "plentiful supply." It is an expression which we might as well discontinue; for whenever an article is in season, here it is sure to be. It matters not how scarce it may be elsewhere, it is safe to find its way to this great whirlpool of consumption, and that, too, in such quantities as would at first appear almost incredible to those who are unacquainted with such matters. Walking along Piccadilly one evening, a year or two ago, in company with a friend from the northern provinces, we met one of those immense four-wheeled waggons, drawn by three horses, and laden with *lettuces*, on its way to Covent Garden. My friend was attracted by what was to him an unusual sight, and after wondering first at the quantity, and then at the ingenious architect who could build a load of lettuces as high above the sides of the waggon, as the sides of the waggon were above the ground, he asked, "Is that all *one man's* growth?" We were, of course, a little amused at the question, which we answered by pointing his attention a few hundred yards further, where there were two more such waggons of the same article, and "all *one man's* growth," and such was this "one man's" contribution in this one article every market-day during the lettuce season. But this was only one man's. How many more such waggons passed along Piccadilly that same evening, on the same errand, we could not undertake to say; and how many more passed along a dozen of the other great metropolitan approaches, we are afraid to say. And thus it is in proportion with all other garden produce.

During the past week, then, the supply both of fruit and vegetables has been plentiful. APPLES continue to advance in price since last week's quotations. *Blenheim Pippins* are very fine, handsome, and highly coloured; when fully matured by keeping, they will, after assuming their yellow hue, be very beautiful. Some of them brought from 7s. 6d. to 8s. per bushel. *Ribston Pippins* have also been very fine, and made 8s. We were rather surprised to see a parcel of *Golden Knobs* so early; the usual time for them to make their appearance being about Christmas. *Kentish Broadend*, a good kitchen apple for present use, was sold at 4s. and 5s. per bushel. In the centre arcade, we found the first exposition of imported *Newtown Pippins*, and the *Lady Apple*—both from America. We shall have to remark upon these on a future occasion. *Fearn's Pippin* is abundant; and there are a few *Golden Reinettes*. Some small *Emperor Alexanders* tried to introduce themselves as *Ribston Pippins*; but notwithstanding their very elegant card and gay exterior the hoax was too apparent. Such stratagems won't do; we would rather have the genuine article from the apple-woman's tray, with its "Ribstone Pippings"

on a piece of dirty whity-brown, than patronize such dishonest attempts. In PEARS we have nothing new to notice in addition to what has been stated in former reports. *Beurré Capiaumont* continues plentiful, of fine quality, and some very beautiful, suggesting, by their fine, glowing, clear orange-russet coat, the adoption of one of its other names—*Aurore*. *Duchess d'Angoulême* is fine and tempting. *Marie Louise* good and handsome; and *Beurré Bose* rich and melting. These constitute the principal of the choice varieties; there are, however, several other inferior orchard varieties, which it would be neither pleasant nor profitable to enumerate. There have been some very fine hothouse GRAPES offered during the week, as *Black Hamburgs*, *Muscats*, and *White Frontignacs*, the prices varying from 1s. 6d. to 6s. per pound.

Of VEGETABLES we have nothing to say beyond what we stated last week; prices are the same, and there is nothing new in the supply. POTATOES have had a bad sale during the week, in consequence of an unusually great supply brought by the Great Northern Railway, so that while last week *Regents* made from £7 to £8 per ton, this week they have with difficulty made £5 to £5 10s. This is a common occurrence in our markets; a sudden rise invariably produces a great arrival, and the supply being greater than the demand, salesmen, to save demurrage on vessels, railway trucks, &c., must force a sale, and so the markets fall.

CUT FLOWERS consist of *Camellias*, *Scarlet Geraniums*, *Heliotropes*, *Fuchsias*, *Roses*, *Cinerarias*, *Violets*, *Verbenas*, and *Ceanothus azureus*. By way of giving our friends in the country the *modes* as regards the arrangement of bouquets, we shall, from time to time, furnish descriptions of any which strike us as being particularly chaste or elegant. One, from its simplicity and beauty, attracted our notice during the past week. It was of the usual size, viz., about eight inches in diameter. The centre was a double White Camellia, round which were arranged a double Red Camellia, and a bunch of double Blue Violets alternately, to the number of six in all; the bunches of Violets being of the same size as the double Red Camellia; between the Violets and the Camellias on the outer margin, was a spike of *Mignette*, and the whole fringed round with leaves of the Rose-scented Geranium. Next week we shall give some more illustrations. H.

GOSSIP

THE value of *Orchids* is still well-sustained, for at a sale of an old-established private collection of them on the 22nd of October, by Mr. Stevens, at his auction rooms in King Street, Covent Garden, the following prices were realised:—*Aërides quinquevulnerum*, £14 14s.; *Lelia superbiens*, a fine specimen, £4; *Cœlogyne cristata*, a large and beautiful plant, £5 5s.; *Dendrobium formosum*, healthy and noble plant, with eight flowering bulbs, £11 10s.; *Dendrobium albo-sanguineum*, fine specimen, £7 15s.; *Phalenopsis grandiflora*, a splendid plant, £13 10s.; *Vanda teres*, a very large plant, £7; *Sacco-*

labium guttatum, £6 5s., besides about one-hundred-and-fifty other specimens, which realised prices varying between twenty shillings and five pounds.

On more than one occasion we have impressed upon our readers the importance of using *manure in a liquid state*, but the subject is far from exhausted, and we have been waiting for an opportunity to give a further notice of the highly valuable "Minutes of Information" recently issued by the Board of Health "On the Practical application of Sewer-water." However, as many who read would be well pleased to inspect the results of such application, we call their attention to the following communication:—

"A short time since we inspected some works constructed by Mr. Freeman Roe, hydraulic engineer, of Bridgefield House, Wandsworth, Surrey, for applying liquid manure to his garden and a small field, consisting together of about three acres. The following is a slight description of the works constructed to effect the object in view.—The refuse of the house and stables is conveyed to an iron tank in the stable-yard, situated about thirty yards from the house, and there diluted with water. There is another tank in the loft of the coach-house, to which the water is laid on, and connected therewith is a pump, by means of which the manure in the tank in the yard is pumped up. In the upper tank the manure is diluted to the required strength for distribution. From the last-mentioned tank there is a pipe connecting it with an iron main of an inch-and-a-half diameter, which is laid under the gravel walk running along the entire length of the garden. To this main there are four hydrants attached at different points, and by means of hose the whole or any part of the grounds can be irrigated at pleasure. The hydrants are well worthy of attention, as combining not only very great simplicity of construction, but also another very important feature, that of economy. They entirely supersede the old mode of using posts and sluice-cocks, and there is very great improvement in the mode of attaching the stand-pipe to the hydrant, which is at once simple and effectual. Mr. Roe favoured us with a *fact*, illustrating the superiority of liquid manure over the ordinary process. He has two beds of celery, planted about seven weeks since; to one he has applied liquid manure—the other has been treated in the usual way. A root was drawn from each bed. That treated with liquid manure measured about twenty inches in length, and four inches in circumference; the other root measured only eight inches in length, and an inch-and-a-half in circumference. We have since had another opportunity of inspecting the two beds, and the difference was still more surprising. Such a fact as this speaks for itself.

"We had nearly omitted to mention, that, by a very simple arrangement, Mr. Roe can irrigate his grounds either with water or by liquid manure."

A correspondent writes to inquire whether the celebrated rose-growers, Messrs. Paul, "are relatives of the celebrated *Paul Jones*?" At first we thought that this was an attempt to have a sly thrust at those gentlemen; but as our correspondent referred us to a volume, showing that the celebrated pirate had been a gardener, and was really a Paul, we have procured the volume (*Burke's Anecdotes of the Aristocracy*), and this is the narrative:—

"Paul Jones was born and bred at St. Mary's Isle, the estate of Lord Selkirk, near Kirkeudbright; his father, by name Paul, a steady methodical Scotchman, being head gardener to the Earl, and young Paul acting in a subordinate capacity in the same establishment. In the gardens were two summer-houses, corresponding to each other. One day Lord Selkirk, during his walks, observed a man locked up in one of them, and looking out of the window; in the other summer-house, looking out of the corresponding window, appeared young John Paul. 'Why are those lads

confined?' said Lord Selkirk to the gardener. 'My lord, I caught that rascal stealing your lordship's fruit.' 'But there are two; what has your son done; is he, too, guilty?' 'Oh! no, please your lordship, I only just put him in for *symmetry*.'"

At the *North Staffordshire Agricultural Society's Show*, held at Stoke-upon-Trent, on the 7th of October,

"The poultry stand was a new and highly interesting feature of the exhibition, and towards it all steps were bent immediately on entering the show-yard. Considering the short time within which this part of the show was got up, we may consider it an excellent beginning of a very useful department for the encouragement of one of the most pleasing of rural pursuits. The catalogue contained thirty-two entries (and owing to the short intimation given of the society's intention of having a show in this department, many pens were exhibited whose entries were received too late for insertion in the catalogue), comprising Cochin-China fowls, exhibited by Mr. William Green, of Longton; Captain Blackburne, of Light Oaks; Dr. Gwynne, of Sandbach; Miss Wilson Patten, and Mr. Joseph Bull, jun., of Longton. Those of Mr. Green, in the first class, were valued at as much as £30 the pair. Spanish fowls were exhibited by Captain Blackburne, and Mr. William Mason, of Hardwick; a pair belonging to the former gentleman were valued at £6. Mr. John Stubbs, of Weston Hall, was an exhibitor of several pens of silver-spangled Hamburg fowls; Miss Wilson Patten, of Dorkings; Captain Blackburne, of American turkeys, and half-bred American and French fowls; and George Tallet, Esq., of Oriental fowls—varieties, Cochin-China and Shanghai. The stud of Mr. Tallet, which is exceedingly beautiful, has been entirely raised in the space of fifteen months from Mr. Simpson's (of Sandbach) stock, collected from the best breeds. The Duke of Sutherland sent black Spanish, silver-pencilled Hamburgs, Andalusian, frizzled and silky fowls (the two latter descriptions being both rare and curious), and Rouen and white-crested ducks. B. H. Allen, Esq., exhibited some white Cochin-China, white Dorkings, gray Dorkings, white turkeys, gold and silver-laced bantams, and cross-bred Cochin-China and Dorking fowls; and the Rev. John Sneyd, some fine Norfolk turkeys. There were likewise pens of Chinese golden pheasants, and of gold and silver-laced Poland chickens. Most of these were commended, as they deserved to be, for their beauty, purity, and rarity, and to some of them prizes were awarded.

"The first prize of £1 1s., in Class 1, was awarded to Mr. Wm. Green, of Longton, for a Cochin-China cock and hen, valued at £30 the pair. The second prize of 10s. 6d. to Dr. Gwynne, of Sandbach, for a cock and hen, six months old, valued at £21 the pair. In Class 2, the prize of £1 1s. was awarded to Dr. Gwynne, for a Cochin-China cock hatched in April, and three pullets hatched in March last. The prize of 10s. 6d. was awarded to Captain Blackburne, for a cock hatched in March, and two pullets hatched in April last. A cock and two pullets, belonging to Mr. Wm. Green, were commended. In Class 3, several pens of Silver-spangled Hamburg fowls, the property of Mr. John Stubbs, of Weston Hall, were highly commended; also some Dorking drakes and ducks, belonging to Miss Wilson Patten, some American turkeys, belonging to Captain Blackburne, and the valuable stud of Oriental fowls exhibited by George Tallet, Esq., which comprised the grouse-feathered sub-variety, the black game variety, the Ptarmigan variety, the cinnamon variety, the purple variety, and the partridge-feathered variety, all raised, as already stated, within the last fifteen months, from Mr. Simpson's stock, selected from the best breeds."

The following is a list of the *Horticultural and Poultry Shows* of which we are at present aware. We shall be obliged by any of our readers sending us additions to the list, and giving the address of the Secretaries.

HORTICULTURAL SHOWS.

BURY ST. EDMUNDS, Nov. 26 (Chrysanthemums). (Sec. G. P. Clay, Esq.)

CALEDONIAN (Inverleith Row), Edinburgh, Dec. 2.
 HAMPSHIRE, Nov. 18 (Winchester). (Sec. Rev. F. Wickham, Winchester.)
 LONDON FLORICULTURAL (Exeter Hall, Strand), Nov. 9+, 23, Dec. 14+.
 NORTH LONDON, Nov. 23, Chrysanthemum.
 SOUTH LONDON (ROYAL), Nov. 11+, Dec. 9+, 16.

POULTRY SHOWS.

BIRMINGHAM AND MIDLAND COUNTIES, 14th, 15th, 16th, and 17th December.
 BRISTOL AGRICULTURAL, December 7th, 8th, and 9th. (Sec. James Marmont.)
 CORNWALL (PENZANCE), January 10th, and 11th. (Secs. Rev. W. W. Wingfield, Gulval Vicarage, and E. H. Rodd, Esq.)
 DORCHESTER, Nov. 18th. (Sec., G. J. Andrews, Esq., Dorchester.)
 HONIFON, January 12th. (Sec. H. K. Venn.)
 WINCHESTER, December 1st. (Secs. G. W. Johnson and J. Colson.)

† For seedlings only.

COMBINATION OF FRUIT AND VEGETABLE CULTURE.

THIS may at first sight seem an easy affair, but, judging from the many very bad specimens of gardening in this way we have met with, the reverse would seem to be the fact. A demand seems to exist amongst one portion of the subscribers to this work to possess some sound information concerning it, and, as we must try to attend to all the interests confided to the advice of THE COTTAGE GARDENER, the sooner it is proceeded with the better, on account of the planting season.

One correspondent, who may be fairly taken as a sample, wishes to plant a first-rate Orchard on this system, and says, "I mention the land being my own, to convey to you that I should spare neither pains nor fair expense in having a first-rate Orchard." He says, also, "The soil is a clay marl, (!) eighteen inches deep, on a clay subsoil six inches, and under is marl an endless depth. I have had it drained; pipes are put below the clay into the marl. I have been cultivating it with parsnips, carrots, potatoes, and cabbage, and I mean to continue this." Now this is not only a possible, but a highly eligible course, especially in these times, when recent political changes lead men to consider whether even their garden policies may not be changed, or modified, to meet the times.

Now, although this mode of mixing fruit with vegetable culture has been much decried by some public advisers, yet, with proper management, we think it the very best plan, economically or for convenience. In the first place, many of our readers require the use of both daily, and have not space for a distinct Orchard. They may also desire so to cultivate it as to make it not only serve their family, but turn to some profit in the market by the sale of surplus stuff. Another matter; a garden of this kind is exceedingly interesting the whole year, and this can scarcely be said of the Orchard alone, and it affords healthful exercise continually for those who enjoy a little out-door employ; the pleasure of which is continually enhanced by the sight or thought of Ribston's, of the Maria Louise Pear, or luscious Plums, and the useful Damson, to say nothing of the bush-fruit.

We rejoice to think that such are extending rapidly, and hope to be the medium of suggesting useful ideas, founded on much experience and constant practice, to those about to commence, and who, to excel, should measure their steps carefully. It is needless to discuss soils in the present paper, any farther than to observe, that almost any soil is convertible into this double purpose by skill, labour, and material. Of course, those

which require most, involve the largest outlay, together with reduced chances of that amount of success, without which it cannot prove satisfactory. A good sound loam, slightly adhesive, resting on a dry bottom, is best of all, and should be from a foot to thirty inches deep; the nearer the latter the better for growing good sized trees. Where the soil is only a foot or less, a dwarfing system had better be adopted. Whatever soils are selected, it should be made a *sine qua non* that the subsoil be dry, or rendered so. Peaty soils are probably the worst; but, barring the extra expense of improving, give no cause for despair. Loose sands are the most unfortunate of all; but these might be made to carry damsons, some cherries, and gooseberries. We, lately, saw some good examples of culture of this kind about Hexham, in Northumberland, at least, such they appeared from the windows of our steamer; but the rate at which we were whisked from Carlisle to Newcastle precluded the possibility of making any accurate observation. One of the principal things in this system, is to see that a very liberal width is allowed *between* the rows of trees, at the same time planting them what might be called pretty close *in* the rows. There needs some "breathing room" between the rows, besides cultural space; but it will be observed, no cultural operations but such as have a reference to the roots of the trees, may be permitted between them *in the rows*. Such, at least, should be our practice; and we dare not advise any other.

Another principle must be pointed to: there must be no irregularity in cropping; everything must be in straight lines, and the rows of trees run, if possible, north and south. Any dodging irregularity, any breaking in here and there because the trees in such places have not made equal progress with the rest, will assuredly compromise the chief end and lead to confusion.

Next in importance to good breathing room, is a recognition of a maxim which we long since suggested in these pages, viz., that every fruit tree should, under all circumstances, have a piece of ground peculiarly its own. It is, indeed, the want of a full appreciation of this which has caused three-fourths of the bungling in fruit-culture from time immemorial. Our pot-cultivators of fruits recognise its importance; who ever hears tell of the great Mr. Potvine (not Poittevin) trowelling over the surface of his Hambro's in large pots, and full of swelling fruit, and trying to steal a crop of small salad or lettuce from the surface, not merely at the expense of the quality of the soil given to the vines, but at the cost of valuable fibres; every one of which is wanted constantly on duty; aye, and more too, if procurable? This then, we urge, is the true policy in our present case.

Having planned the *Garden-Orchard*, for we must endeavour to coin a name for this necessary evil, as to size, distance, &c., &c., let beds of soil be thrown up nearly a foot above the ordinary ground-level, in lines where the rows of trees are to be planted: these beds to be four feet wide at first, and continuous, lengthwise. The trees being planted in these lines will, when fixed, have nearly half the depth of their roots above the ground-level, a necessary procedure both for distinctness and in order to keep them as much as possible from descending into the subsoil. This four-foot border will suffice during the first three years, and after this we would make a point of adding one foot on each side every second year. Thus, in the fourth year, it would be six feet; in the sixth, eight feet; and in the eighth year ten feet, which we should consider the final width, unless for very large orchard trees. At the first setting-out there should be an alley of two feet for operations; and this, on making each two year's addition to the border, would have, of course, to recede a foot farther from the trees on each side of the row. On thus removing the alley, occasion may be taken to add extra

nourishment to any delicate tree, by introducing it in the hollow before filling it up.

And now a few words of advice as to the disposal of the borders on which the trees are planted, for we fancy we hear our friend Turn-to-account whisper, that a good deal of surface will be monopolised by these fruit trees: and that he should wish these borders to assist in paying his rental before the trees commence bearing. Certainly; as no produce of any account may be counted on until a third summer after planting, we really must cast about and see if we can serve our friend; but in so doing, we fear being laid open to the charge of inconsistency. It is well known that we have been preaching up *no-culture* for years on fruit borders: "no surrender" has been the word. And, as our good friend Beaton would perhaps say, in a like fix, "the cat will get out of the bag." It so happens, that all the time this doctrine has been broached, we have been slyly stealing a few Dutch turnips from such borders; have even had strawberry edgings, or edgings of curled parsley.

It verily became necessary, after so much digging and cropping over the roots of fruit-trees since the "good old days of Adam and Eve," to try and turn the current another way; and we did, indeed, deem it prudent to take such dangerous weapons as the spade from inexperienced hands; and not only the spade, but the fork, and even hoe for awhile, in order to let the question assume its proper shape. Now that we think and hope that the great bulk of those interested in the garden orchard really begin to appreciate the non-interference policy, we are quite willing to restore them their forks again, and by all means their hoes. Here, one thing must be observed: it is not so much the abstraction of the virtues of the soil that we dread, but the continual shaving away those finer surface fibres which seem disposed to woo the atmosphere, and by which, indeed, the whole system of the tree becomes more sensitive to the invigorating influences of the solar rays. As for the loss in the soil, that can be replaced; and we must some day point to the propriety of top-dressings every three years after the trees have attained a certain age, and well repaid former attentions by abundant crops. Now, there can be no great objection to taking any such crops as can be obtained by from two to three inches' deep culture, although much better avoided. Having practised such things for years, we are in a position to say, that where depth may not be attained by cultural processes, an equivalent must be sought, and that in the shape of manurial matters. With regard to the Dutch turnips, which on account of their moderate tops, and early tendency to bulb, we do hold to be the best things in the main, they may be obtained at easy cost, by merely hoeing the seeds in, killing a crop of weeds at the same time. This we have done scores of times, and the turnips are invariably better for home use than those from deeply dug or enriched soils, which, by throwing them more into top, depreciates their qualities as food for man.

But these are conveniences as matters of profit, not of particular account. Our plan has been to sow Dutch turnips on such borders in the last week of February, or first week of March, in order to get a strong plant before the fruit trees had much foliage, and the only dressing used has been some of the burnt or charred ashes, soil covering, &c., from the rubbish yard. We never sow them nearer than two feet.

Our readers will now naturally desire to know what we think the best distance at which to plant their trees. As to the distance *between the lines* in a *Garden-Orchard*, we say, the wider the better; but, as our small garden men cannot carry out their objects with too high a standard, we think that ten feet of open soil may be the minimum. By open soil is meant the available space for culture when the trees have come into full

bearing; and, be it understood, that although we adhere to strictly-defined lines or boundaries of crops, we place our main reliance on that portion beyond the damaging influence of the branches of the fruit trees. In the rows, we would allow only twelve feet for dwarf standards; tall standards might require nearly double the distance. Before concluding, we may point to the great propriety of those about to establish gardens of this character, of taking into consideration our *platform mode* of planting, full accounts of which will be found in by-gone numbers, the possession of which we consider absolutely necessary to a full appreciation of planting based on root-control and root-culture, the two leading points in a dwarfing system; which dwarfing system, being fairly translated, means early profit, little trouble, and no vegetable suffocation. Allowing each tree, when full grown, to reach nine feet each way, this, with a couple of alleys of two feet each, and ten feet clear cropping ground, would demand, at least, thirty feet from row to row; if forty, all the better.

R. ERRINGTON.

MEETING OF THE HORTICULTURAL SOCIETY—OCTOBER 19, 1852.

THIS was the first gathering of the Society under the new regulations for the exhibition of *special subjects*, in addition to the usual run of garden produce. The special subjects for this day's exhibition were—*Hardy Annuals*, on their own roots, or as cut flowers; *Dessert Peas* now ready for the table; and *Green Peas* in a fit state to "sauce" a Michaelmas goose. There are certain other *specials* named for each monthly meeting, but all sorts of garden produce may be staged on each occasion, as formerly. Foreigners may also compete at these meetings; so that if we are obliged to take the best of their wheats and barleys, we may also get a share of their best cabbages. But we have the better of them this time, so far that they are not allowed to compete against us, only to fight it out amongst themselves; and if a Britisher tries his luck with foreign productions, as a salesman in Covent-Garden Market did on this the first starting day, he will be pitted against a foreigner; and if there is no foreigner to face against him, his things will be judged without reference to home growth. All this is useful, and a great improvement on the old doings of the Society. Of all the *specials* we had an overflowing abundance. Also an overflow of cut Roses, just as they put them up for the summer exhibitions, together with stove and greenhouse plants, and *novelties*, of which (it is but fair) I shall first tell the particulars.

Two splendid examples of the lovely *Vanda cœrulea*, and two or three plants of the finest and most useful hardy evergreen that has been introduced since the Rhododendron was discovered, the coral-fruited *Skimmia japonica*. I would not have lost the sight for a dinner with the Lord Mayor. It seems but the other day that we first heard of such a thing as a blue Vanda; and when we did hear of it, through Mr. Griffiths, who sent over the dried specimens, we did not know exactly where to send for it, only that it grew on a long-wooded range as they go from Sylhet to Assam, the Kaisa or Coosya range; but now Mr. Stevens hammers it away at his auction-room like an ordinary plant. As for the *Skimmia*, although it was named before I was born, there was hardly a botanist in Europe who believed in the existence of such a thing four years since, for there are two marks of doubt against the genus in the last edition of "The Vegetable Kingdom."

The *Vanda cœrulea*, when not in bloom, might pass for some species of the *Aerides*. The flower-stems rise upright first, and then bend gracefully over; the flowers

are not so thick and fleshy as those of the other species, but they are as large, or larger, than those of *Zygopetalum Mackayii*; the sepals and petals are of equal size, and the lip is narrow, and in one of the plants it was of a deeper blue than the other. The flowers are set wide apart on the stalk, and they stand out well from it, on a tube-like pedicel, allowing a free expansion to them on all sides. The colour of the whole is a delicate light blue, something like the colour of the large blue Clematis (*C. cœrulea grandiflora*), or between that and the blue of the *Agapanthus*. Altogether it is a most beautiful thing. There were from ten to twelve full expanded blossoms on each spike, occupying a space of about a foot in length; but when the plant has more time, under good cultivation, we may expect all this to be much increased.

The *Skimmia japonica* was named by Thunberg, and described in his "Flora Japonica," in 1784, when he returned from his travels in the East to occupy the same chair from which he received the first lessons in botany from Linnæus himself. Dr. Siebold missed this plant, as also did Hensall. But Mr. Fortune, always lucky, got hold of it, and the Messrs. Standish and Noble, of Bagshot, have brought it out in first-rate style; as all new plants ought first to be exhibited. It is a dwarf, bushy evergreen, which you might take for a Pontic Rhododendron at a little distance off, but the leaves are thicker, more fleshy, and not leathery, as in this Rhododendron. They are also of a darker green, quite smooth on both sides, and entire round the edges, and without stipules, like all Hollyworts, the order to which it belongs. It flowers in the spring in heads at the extremity of the branches, just like a Rhododendron. The flowers are quite small, individually; whitish, and as sweet as violets. The great beauty of the plant is in its berries. These are now of the same size and colour as those of a bright-berried Hawthorn or Holly, and stand out in prominent clusters exactly as in the common ivy; but Mr. Fortune told me that when the berries are quite ripe, they are as bright and shine like corals. Here, then, is a new plant that will make a scarlet bed all through the winter, to succeed the *Tom Thumbs*, and is equally gay. I believe Thunberg said it grows a yard high, but Mr. Fortune did not see it more than half that height. It is very bushy, however, and all the better for being so dwarf. We have only to imagine a large plot of ground quite covered with three-year-old seedling common Rhododendrons, and these studded all over the surface with Christmas holly berries, and that is just a picture of a bed of *Skimmia japonica*, as nearly as I can paint it. I shall go down to Bagshot some day to learn how they increase it, what kind of soil it likes best, and all about it. There were berries enough on the plant that was exhibited on this occasion to produce some hundreds of plants; for all the berries in this small order yield from two to six seeds each, and the plant seems to flower as early from seeds as the new *Rhododendron ciliatum*, that is, in two years at the farthest.

The next best plant on the table for a gardener, according to my ideas, was one of those dwarf, small-flowering *Chrysanthemums*, called *Pompones*. Some of us gardeners are really very stupid, and more stupid than the rest were those of us who railed against Mr. Fortune for sending home a still more stupid thing, as they called the pretty Chusan Daisy. But a gardener who had seen more than half round the world, and who could send a covey of daring pirates to another kingdom with an old blunderbuss, was not born to be stupid. The first moment he put his eye on this daisy, the image of a new race rose before him, and here am I recommending the very earliest of this race, called *Hendersonii*, because it comes in full three weeks before the old *Chrysanthemums*, just at that period of the whole year when house flowers

are scarcest. It is as pretty as any of them; brownish-yellow, and as double as a bachelor's button. The plant was also the best grown in the room, and I think it was from our own garden, at Chiswick. I hope the judges will bear this in mind next show day, and not be led away by the size of the flowers of *Chrysanthemum*. We in the country, and all who have a grain of common sense, look for the greatest quantity of well-formed flowers which a given plant is capable of sustaining under a system of *close specimen* kind of growth.

You may just as well give sweet cakes to a baby's doll, as give away our money for *cut flowers of the Chrysanthemum*, for that will never raise gardening one inch on the scale of excellence; and if you urge that the ladies like to see them better that way, you must be met by the fact that far better samples of skill and ingenuity may be seen in the shop windows of the milliners.

The most celebrated plant in the room was a cut specimen, in bloom, of the true Peruvian Bark tree (*Cinchona calisaya*). The first, as we were told, that has flowered in Europe. It was from the Society's garden. The flowers are produced, as in *Tacora*, of a pale whitish colour, but the plant is not worth growing for the flowers. *Solandra levis* was there also, from the garden of the Society. A first-rate stove plant that blooms always at this season, and seems much easier to flower than the old *S. grandiflora*, but the flowers of both are much alike, large, white, and somewhat bell-shaped. No plants are more easy to grow and propagate, but the difficulty is to flower them well; and the way to do that is to give them a long season of rest in a perfectly dry hot atmosphere, without a drop of water till the young wood begins to shrivel. This *levis* is rather new, having only flowered for the first time in England in 1847, at Mr. Pince's nursery at Exeter. There was a nice-looking *Gesnera* from Mr. Glendinning, which looked as if it were a cross between *purpurea* and *discolor*. A fine dwarf plant of *Medinilla Sieboldii* was there in fruit and flower. The flowers are pale pink, in bunches; and I believe they said the berries were to be of a high colour when ripe; it seemed the best of them for a small house, as this plant was quite bushy, and not higher than a fancy geranium. A fine tall plant of *Dichorisandra* coming into flower,—a very useful thing at this season, and easy enough to grow and flower in a stove, and then to stand in a flower-house for full two months in fine blue bloom. This is, also, one of those free-and-easy plants from the stove that will grow out-of-doors from the end of June, and look better than in the orchid-house. I had it so growing many years since. But speaking of house plants for out-door culture reminds me that we had here a new rival for the variegated and blotched-leaved section, which I wish so much to see tried in the open air in July, August, and September. It was from Mr. Low, of Clapton, where I saw lots of it when I went to learn about the packing for long voyages, and where I booked it, and a great many other things, for these pages. The name is *Plectranthus concolor-picta*, a plant looking somewhat like a *Salvia splendens*, but with leaves much paler, and of more varied outline; and in the centre of each leaf there is a large blotch of purple-brown, as if a painter had touched it with his brush accidentally. It is, certainly, unique, and well worth adding to every collection of variegated plants in the kingdom. The less that is said about the flowers of any *Plectranthus* the better.

There was a fine specimen, in the shape of a cut top, of the *Aralia japonica* in flower, from Mr. Snow, gardener to Earl de Grey. It was the finest of the kind I ever saw, and it was but one panicle out of a great many now adorning this very fine shrub, and as it is very seldom seen, I must give some idea of it, as I always attempt to do when I write about any new or uncommon

plant. The flowers are small, white, but very numerous produced along the side spikes of a large loose panicle, coming out at the end of the branches, exactly as they do in *Kœlreuteria paniculata*, another beautiful hardy tree that is not planted half so much as it deserves to be. As Mr. Fish lives not far from Mr. Snow, perhaps he could fish out how this beautiful *Aralia* was treated to get it out so fine; and, indeed, any of our correspondents who may happen to have old established plants of it, would confer a benefit by a sketch of the proper culture. A little Begonia-looking plant, with racemes of small, bright lilac flowers, called *Puya zelanica*, was curious and well worth growing in a small collection of stove plants, as it requires but very little room. *Guzmania tricolor*, an old member of the Bromeliads, looking like a stunted pine-apple plant, had a spike of bloom up from the centre, just in the shape of a pine-apple when it first shows. I never saw this plant in flower before, and it is certainly very pretty and very curious, after this fashion—on the top, where the crown of the pine-apple shows, there is a close bunch of leafy bracts, in crimson-scarlet; below that, and where the pips of a pine-apple would stand, the buds of the flowers were peeping out from between the bracts, just like the tops of so many white crocuses in bud, and the colour of the bracts round their white buds, so to speak, was green, or brown, or streaked, altogether forming the *tricolor* to perfection. None of these Bromeliads are difficult to grow, and they come from suckers as freely as the pine-apple, and they often seed. I am quite sure that most of the store ones would grow and flower beautifully without a particle of soil, like air plants, only having their scanty roots placed in balls of moss, and wound round with small copper wire; then to hang them up against walls, posts, or pillars, and to keep the hollow of the leaves always quite brim full of water, and also to dip the mossy balls continually in water, as Mr. Jackson, of Kingston, does with the lovely *Vriesia speciosa*, alias *Tilandsia splendens*, of which I saw a large stock of seedlings with Mr. Low, at Clapton, the prettiest little things you ever saw, except a drove of speckled fawns or kids. There were two more plants of this order in the way of *Pitcairnea*, one of them very handsome, and the other no-matter-what. The right one put up a flower-stem from the middle, in the usual way, and on the top was a fine crimson head of flowers; the second plant grew in the same way, but the flower-head was a greenish-white. Take a crimson *Love-lies-bleeding* or *Coxcomb* in one hand, and their white varieties in the other, and you have the contrast of these Pitcairns, or whatever they may be, to the very letter. An African traveller showed me a little yellow *Lachenalia*, at one of the Regent Park Exhibitions this last summer, and a dried specimen of a Yellow Geranium one day at Chiswick. I thought the man was daft for his pains. I think otherwise now, after seeing this very pretty species of *Lachenalia* at this meeting. I think it was from the garden of the Society; at any rate, it was capitally grown, and when the bulbs are stronger this will become as a general favourite as *Lachenalia tricolor*, and is well worth having. With the exception of these two species, all the *Lachenalias*, and some of them are very pretty, ought to be set in pure silver-sand, and put in very shallow in the pot, with about half-an-inch of sandy peat on the top, and rough turfy peat, with good drainage, below, and no water ever allowed to get in between the leaves, these bulbs being so touchy that the slightest mishap will rot them. There was a large specimen of *Plumbago Lar-pentæ*, which was in fine bloom when I was at Chiswick in September, but now was too late for it. Also a fine plant of *Sedum Sieboldii*, a plant that is admirably suited for a small neutral bed in an architectural or terrace garden, the effect being more from the sea-green of the leaves, than from the purple blossoms in the autumn.

There was a little plant of *Campanula Vidallii*, which did not show the full character of the species. I heard it run down in one or two places in Oxfordshire because it would not stand the rain; but I have not seen it anywhere so that I could pass a decided opinion of it as a bedding-plant, for which it was first given out.

There was a very pretty, pure white, new, *Trichophyllum* from Mr. Bellenden Kerr; also a botanical *Dendrobium* from some one; another botanical, or, rather, a Manchester plant in fruit, "The Sea Island Cotton Plant;" with *Abelia rupestris*, and twenty-seven kinds of annuals, altogether making a good October meeting without yet coming to the *specials*, of which these annuals are a part. *Cosmos bipinnata* and *Coreopsis filifolia* are the only two out of the lot that are less known to the readers of this work. The *Cosmos* is an excellent wilderness plant, looking as if flowers of the Beauty of Thetford Dahlia—the best of all the single ones—were placed on some loose-growing, fennel-like plant, rising from three to four feet. The *filifolia* *Coreopsis* is so much like the *Drummondii* in flower, that it is not worth a place for its thready leaves. *Lupinus rivularis* is also not so much known as it ought. It is a much deeper blue than *Hartwegii*, and it is less dense in the growth and leaves; but in every other respect, as to height, time of flowering, and treatment, it is the same as *Hartwegii*.

A large bed of the best annual Lupins ought to stand thus—*Mutabilis*, four feet high, in the centre of the bed; a row of *Lupinus Hartwegii*, as being the next in light blue shade; the third row to be of *rivularis*, a darker blue; the fourth, also a row of *rivularis*, to be cut in to eighteen inches high, and not to allow it to rise higher all the season; and the outside row to be of *Lupinus nanus*. Then there would be a regular face of leaves from the ground level, and the best shading that can be made out of *Lupinus*. The whole would keep in flower till October; and the reason why I mention it, is to show that without the second row of *rivularis*, and that kept to a certain height, to suit the rows on each side of it, the arrangement would be a failure, because there would be too great a step between the flowers of *nanus* on the outside, and those of *rivularis*. This great blemish is often coming in now in plans of flower-gardens, and nothing looks worse.

There was a large pan of the gem of *carpet plants*; also an annual, *Cochlearia acaulis*, only two inches high, and all flower, and so easy to grow, that it only requires once to get a footing to keep itself from year to year, especially in a peat bed. The lecturer was very earnest in pressing and explaining all this, and he gave a new turn to the subject this time, which set my teeth on edge. This *Cochlearia*, with its pretty white and blue flowers, may be had on the mantel-piece, or anywhere else in a room, everyday in the year; and not only that, but it will do as well in the saucer of a tea-cup as in the best pot. The way to do it is this—to keep sowing it at different times, and to let it sow itself, so as to have some always in the borders. Then to take your saucer, or little vase, to the border, fill it nearly with soil, and take up patches of this plant in bloom, press them on the top of the mould in your vessel, and next day they are in full bloom. They will last three weeks; then fill again, and so the whole season. If they get behind in flowering out-of-doors, take them up all the same, and the heat of a room will soon cause them to flower. All this was new to me; and I shall never take the spoon out of another man's mouth if I can help it.

Green Peas in pod, and table *Pears*, with *Grapes* and *Pine-apples*, were in abundance, and some were remarkably good.* There was one bunch of a black

* The *Peas* to which were awarded the prize, were *Knights Marrows*, young and excellent, from Mr. Burns, of Chevening. Others, as the

grape, which I would call a monster Black Prince; the weight was 3 lbs. 9 ozs., but the owner, Mr. Butcher, a nurseryman at Stratford-on-Avon, told me that this grape would keep till late in the spring. The name of the grape is *Black Barbarossa*. It had a medal, and it richly deserved one, still, as this is a very little known kind, if the Society did not request to see a bunch or two of it in January and February, or as late as it could be kept fit for the table, they might just as well have thrown this medal over London-bridge. Scotland excelled in table Pears, and it was provoking to hear the lecturer following up this triumph, by raking up the horrors of the winter of 1837-38, when many tender plants stood out "over the borders," that were killed outright about London; and yet I often had a mind to tell Mr. Errington, that if he ever wanted to see pear and peach-trees in perfection, he would need to go into Fife, Perth, or Morayshire, for the sight. The island of Jersey never sent out finer pears than a pear at this meeting, called *Grosse Calabasse*, from Mr. Robertson, gardener to Sir A. Dumber, Bart., Dufus House, near Elgin, a day's journey beyond Balmoral, when I was last there. "The Heart of Midlothian" was also represented by splendid Pears from Exenford Castle, two hundred miles nearer Gretna Green than Elgin. After the Elgin Pears, the next largest were *Duchesse d'Angouleme*. We had also Apples, Plums, Morello Cherries, and Guavas.*

D. BEATON.

GREENHOUSE PLANTS SUITABLE FOR POT-CULTURE ON TRELLISES, &c.

PLANTS fitted for this purpose should possess a climbing, twining, or trailing habit. Where conveniences exist, the last division would look most natural if the pot or basket was suspended, and the shoots allowed to fall gracefully over the sides. Many of the others look admirably when twisting round an arch, or dangling from a rafter. But some are rather slow growing for this purpose; and where a great love for such forms of beauty exists, only a small number could thus be grown. When cultivated in pots, on trellises, a greater variety can be obtained, more dense masses of bloom secured, and the plants can be easily moved from place to place, and thus obtain the best position, as the varying circumstances of the plants require. Of the many that might be selected, I shall to-day allude to the *Kennedy* group, merely premising that all the strongest growing are also fitted for rafters, when planted out and grown in larger pots than would be requisite for trellises. The strongest growing will, therefore, be named first.

The genus *Kennedy*, consisting of pea-shaped flowers, is commemorative of Mr. Kennedy, of the late firm of Lee and Kennedy. The plants are all natives of New Holland, Australia, and the Swan River settlement. Much confusion exists in this group since botanists have divided it into other two allied genera—*Hardenbergia*, commemorative of a sister of Baron Hugel, and *Zichya*, in honour of another German lady, a friend or relative of the same gentleman. Was this the proper place, I do not think I could in every case draw a clear distinction between the three genera, as even in the most recent lists they seem very much commingled together, so much so, that beginners could not greatly err in calling the whole lot of them *Kennedias*, at least, until one of our botanical friends will point out a clearly perceptible difference. In most cases, though not in

all, the *Kennedy* has trifoliate leaves, and the keel of the flowers longer than the wings; in *Zichya*, the keel is short, the leaves trifoliate; in *Hardenbergia*, the leaves are mostly simple and long. As a slight difference will be required in the management, I shall give a short list under the several genera.

Kennedy *nigricans*.—Flowers very deep purple, green, and yellow. This, a number of years ago, we had so strong as to threaten to monopolise the whole roof of a house, and when dangling down the flowers had a very singular appearance in the spring months. Many of the *Kennedias* are climbers, but this is such a twiner that it grasped an iron rod so tightly as ultimately to destroy itself.

K. Marryatta.—Fine scarlet flowers; blooms freely from February to June.

K. rubicunda.—Dark dull red; blooming generally from May to July. These, when grown in pots, will require trellises from four to seven feet in height, and eighteen inches in diameter. If in a balloon shape, the widest part may be a foot wider. The smallest trellis for the last-named.

K. Comptoniana.—Blue-lilac.

Hardenbergia macrophylla (Large-leaved).—Scarlet flowers.

H. monophylla (One-leaved).—Blush-purple.

H. longiracemosa (Long-clustered).—Purple-pinkish.

H. ovata (Egg-shaped-leaved).—Purple.

Many of these, if left to themselves, would have as much tendency to trail as to climb. The trellises should range from six feet to three.

Zichya glabrata (Smooth-leaved).—Orange flowers.

Z. sericea (Silky-leaved).—Scarlet; syn. *Kendilata*.

Z. inophylla (Nerved-leaved).—Scarlet flowers.

Z. heterophylla (Various-leaved).—Purple.

Z. tricolor.—Yellow, red, and purple.

These are pretty twining plants, requiring trellises from 3½ to 2 feet in height, and from 30 inches to 18 inches in diameter.

1st. *Propagation*.—When seed can be obtained, sow in February or March, in sandy peat, plunged in a sweet hotbed: steeping the seeds previously for a day in water at 90°; hardening-off the plants gradually, as they get strong enough for pricking-out round the sides of a pot. *By Cuttings*, choose firm, short, side-shoots from two to three inches long, early in spring, or after fresh growth in summer, when the base of the short shoot is getting hard; and insert them in silver sand, over sandy peat, the pot being three-parts filled with drainage, and kept close with a bell-glass; shade when necessary. Give a temperature rather higher than the plant enjoyed from whence the cuttings were taken; and in a month or six weeks plunge the pots, if necessary, in a slight bottom-heat.

2ndly. *Choosing young plants in a Nursery*.—Fix upon the healthiest and bushiest at bottom. But, provided the plants are young and vigorous, though they be rather naked below, it will be of less consequence than if you were purchasing bush plants, to which a good bottoming is everything. This will appear from

3rdly. *The mode of Training*.—When I used to grow such plants I practised two modes. First, I encouraged the plant to grow with a single stem until it was a little higher than the top of the contemplated trellis; then it was stopped, and all side-shoots and buds on the stem were disbudded gradually, after the shortened top was beginning to push out fresh branches. These were allowed to dangle free of each other, or were secured to any temporary prop, so as to have a good beginning before the trellis was introduced. The main stem, by this means, became as clean as a whip-handle, and, in fact, was never seen at all when once the trellis was covered; besides, the sap was distributed more regularly than when the trellis was covered with rival

Long Jonquil, but little known, from Mr. Evershed, market-gardener, of Godalming, and *Early Warwick*, grown by Mr. Smith, gardener to Mrs. Reay, Wansted, were so good as to deserve an extra prize. Some foreign Peas were also exhibited, but these were in very bad condition.

* The pears exhibited by Mr. Robertson, were Winter Neelis, Sinclair, Marie Louise, Easter Beuré, Grosse Calabasse, Thompson's, Duchesse d'Angouleme, and Glout Morceau.

branches from the base. This method I found a good one for causing free-flowering among the stronger-growing *Kennedias* and *Hardenbergias*, from the check given by training the branches downwards. But, again, suppose you have got a plant of the slower-growing *Zichyas*, that you wisely resolve to cover a trellis with, beginning at its base, and you have either got a solitary shoot, or several shoots, bare for a foot or eighteen inches from the surface of the pot; then the best thing you can do is to give the plant the usual good treatment, until the month of April, or the beginning of May. Then prune it back, not to the surface of the pot, but so as, if possible, to retain a few leaves to keep up the circulation; then tie the shoot, or shoots, to the side of the pot, in order to cause it to break more easily. Place the plant in an increase of temperature of ten degrees, and in a moist atmosphere; and if the stem was not very hard and old, you will get plenty of young shoots to choose from. When these are from one to two inches in length, a fresh shift may be given, if the roots require it, and a vigour will be secured that the old stunted stem never would have yielded. Mind, if the stem is *old*, pruning back close to the pot will be likely to end in death. If the stem was quite young, it might be cut back close without danger.

4thly. *Potting*—when should it be done? When the plants are young, and small shifts are given, attend to them as often as necessary. When they become large, once a year will be ample, and that is best done when the plants are commencing to grow freely after flowering, and receiving what slight pruning they require. Established plants on trellises will not want potting for several years, if the surface is freshened up, and weak waterings from old cow-dung given when blooming and growing.

5thly. *Size of pots*.—Eight inches in diameter will grow the smaller *Zichyas*, and those from twelve to sixteen inches will do for the stronger of the allied genera.

6thly. *Trellises*.—These are most convenient if made of wire, and coloured a dark brown or olive-green. Young Larch-trees, peeled so as to have all the twigs left, then thoroughly dried, and either painted or not, do very well, but require to be fixed in the pot—a great disadvantage—and also demand more labour in training. Two things are necessary to be attended to with wire trellises: First, that they should be fixed to the pot, instead of going into the soil; secondly, that they should be round in form, instead of square or semicircular; and, I may add, thirdly, that the training, when the plant is established, ought to hide the trellis, and the twigs hung in massive, careless profusion, instead of each being stuck in its place with mechanical precision. Never forget that the trellis, however pretty, is merely a necessary supporting crutch, and that plants, as well as men, look none the worst when they *seem* independent of such aids.

7thly. *Soil*.—Heath soil must constitute the chief material for all when young, mixed with a little charcoal and broken potsherds, both of the latter being clean and free from dust. As the plants increase in size, a little at first, and then more loam may be added, of a very fibry character, until, for *Kennedias* and *Hardenbergias*, it may constitute one-quarter, peat one-half, and charcoal, broken pots, and sand, another quarter. When the trellis shift is given, the compost should be pre-eminently fibry and rough; but few of the individual pieces should be larger than a walnut, and most of the small earthy matter be excluded, using enough of silver sand, &c., to keep all in an open state when firmly pressed. It would be advisable to use small successive shifts, until the plants filled five-inch pots or more, and then transfer them, by a large shift, to the trellis pot.

8thly. *Watering*.—The roots must never be allowed to become dry, but comparatively little will be wanted

in winter, or in dull weather. If well drained, and the soil open, as advised, they are not easily injured with water, provided its temperature is sufficiently high, and there is no want of light. Plants that have received a large shift must be watered very carefully for the first twelve-months, more especially in winter, as if the unappropriated-by-roots soil, close to the sides of the pots, were soaked and soured, the plant would be greatly injured. A little manure-water may be safely given when the plant is growing after flowering.

9thly. *Pruning*.—This will be required according to the strength of growth, performing the operation after flowering. Prune so as to secure healthy, well-ripened shoots for the next year. In some cases the bloom is chiefly produced near the points of such shoots, but mostly either in single blossoms, or racemes from the axils of the leaves.

10thly. *Time of Flowering*.—This, with the kinds mentioned, may be expected to last from March to the middle of July; earlier or later, according as the plants have been accelerated or retarded, by being kept in a warm or cool greenhouse during the autumn and winter.

11thly. *Temperature*.—They may be kept at from 40° to 48° in winter, but if often below 40°, or in dull cold weather kept long as low, the plants will feel it, and more especially if the soil is wet. I have had fine specimens rendered worthless from cold alone. The leaves, especially of the simple-leaved kinds, seemed as if they had been burned, but the cold it was that scorched them. Were I growing plants as specimens again, my previous experience would point to 45° as the lowest average temperature at night, but I should not like to see them long under 48°, and in fine weather, a couple of degrees higher, with an allowance of 10° more for sunshine. They who study the native climate of these plants, will see the necessity for this. The other seasons may be mostly regulated by *position*. Expose the plants close to the glass in spring; keep them slightly shaded and cool when in bloom; more shaded, closer, and in a moister atmosphere after pruning; freely exposed to the sun in the end of summer; and during the autumn, never putting them out-of-doors at all, unless in warm autumns, in a sheltered place, full in the sun, the pots protected from its rays, the plants housed before cold nights come, and obtaining a *light*, open position all winter. If on circular trellises, they should be turned partly round every other day, that all parts may have light alike.

12thly. *Insects*.—Red Spider sometimes comes—but that, sulphur water, or sulphur fumes, will cause to flit. A worse enemy is a white scale insect. At first, and when thin, washing off with soap water may aid you; but when once colonies are formed, a young plant, or cutting down the old one and commencing anew, are your best remedies; in the latter case scrubbing well the old stems as the preliminary process. Against these annoyances, *cleanliness* and high health are the best safeguards, and for this purpose the syringe and tepid clear water are good agents, applied sparingly in sunny days in winter, and morning and evening in summer and early autumn.

R. FISH.

THE PETUNIA.

THIS is a florist's flower that is advancing in public estimation, both as an ornament to the greenhouse-stage, and to the flower-garden as a bedding-out-plant. Perhaps the best that was ever yet raised is the one known as the *Shrubland Rose Petunia*. It is equally beautiful in the greenhouse, and in beds in the open air, yet I suspect there are several varieties something like it sold for it, and I draw this inference from the fact, that a gentleman from Manchester writes to me for the

true one. He says he has had several that have turned out counterfeits, which, like counterfeit sovereigns, are useless, except to the utterers, when they are not caught in the fact. There is nothing so grievous to the mind of a respectable dealer as that of sending to his customer a plant not true to its name, which he has had from some person in the trade, expecting it to be the genuine variety. If he is largely dealing in any popular plant, and has obtained the origin of his stock from some one that has deceived him, I leave a discerning public to judge how distressing his feelings must be, when he finds he unintentionally has been distributing, to perhaps numerous customers, a plant not true to its name; and what is worse, spreading the mistake, or evil, it may be designated, on account of his high and deserved (except in such a case) character, he has been supplying other men in the trade, equally as respectable as himself, with plants from the false one. This is a great evil, and I think the sending out plants, in the first instance, of any kind not true, ought to be punishable by an expressed law, for there is no knowing how far, through the innocent instrumentality of the honest well-known sterling dealers, the deceit may be spread. These remarks have been drawn from me in consequence of the letter from my Manchester correspondent, and I trust if ever a dealer is found wilfully and knowingly sending out to nurserymen any kind of florist-flower not genuine, that, for the protection of innocent men, and the public in general, such a dealer may be publicly exposed in the gardening periodicals, such exposure to operate not only as a warning to would-be-cheats, but also as a punishment to the actual offender in the first onset.

I have been drawn from my original purpose when commencing this essay on the *Petunia*, and if I have made myself clearly understood, I may hope my remarks may do good, by removing the onus of wrong dealing from the innocent, and placing it where it ought to be, upon the guilty man. The *Petunia* is advancing, not only in public favour, but also with the florist, because it is found capable of improvement by hybridization. I may suppose now that the *Petunia phanicea* is extinct; but I well remember, some twenty years ago, being highly delighted when I first saw the plant in flower. It had then a great degree of beauty, but was without a good form. My young brethren would scarcely recognise it now, in these days of improvement, in form, colour, and substance—the three grand properties of every florist-flower. As I do not desire to omit any flower that can be placed under the class of florist-flowers, I shall devote a week's essay or two to this showy plant—the *Petunia*, and after they are placed in the hands of our Editor, I will give a series of brief descriptive lists of every kind of florist-flower that is worthy of cultivation in 1853, something similar to the one I gave lately of the *Dahlia*. I am aware that this is an onerous task, but I do not shrink from it, being well aware such lists are extremely useful and desirable to the amateur florist, for whose instruction I chiefly write on this subject; and I should be much obliged to every grower of good varieties of any kind of these flowers, if he would send me a true description of every first-rate variety, in order that the list might be complete, and, consequently, more extensive and useful; the descriptions to be classed under the heads—form, substance, colour, size, and habit. Such lists, drawn from various quarters, would be far more complete and essentially useful than any single one that any one dealer might furnish in his catalogue. I hope my wish for these descriptions will be attended to at once, as the season is fast approaching when it will be desirable to put them into the hands of the purchasers, in order that they may procure them in time for the next year. They may either be sent to me, at Victoria Nursery, Uxbridge, at once, or be sent to the Editor, 2, Amen Corner, Paternoster Row, London.

To return to the *Petunia*. In the first place it is desirable to know what are the properties of a good *Petunia*. 1. *Form*.—The flower should be round without notches on the edge, and it should be rather inclined to cup, that is, the outer edges should not bend back. 2. *Substance*.—The petals should be stout, and able to keep the form nearly as long as the colour lasts perfect. 3. *Colour*.—When a self, it should be clear without fading at the edges; when striped, each stripe should be well defined, and each colour distinct. 4. *Size*.—Each flower should be at least one-and-a-half to two inches across; if large they are liable to bend back. 5. *Habit*.—The plant should be rather dwarf, and produce flowers abundantly; the foliage should be rather small, in order that every flower may be seen distinctly. T. APPLEBY.

(To be continued.)

CONIFERÆ.

(Continued from page 46.)

DACRYDIUM.—This name is derived from *dacru*, a tear, on account of the gummy tear-like exudations on the leaves and branches. The foliage of the plants in this genus are singular and ornamental. I had intended, when I first began these essays on *Coniferæ*, to confine myself to the hardy species only; but as *THE COTTAGE GARDENER AND GENTLEMAN'S COMPANION* is now found on the tables of those who have large conservatories, I think my list ought to include such *Coniferæ* as are ornamental and suitable for such garden buildings. For this reason I include the genus at the head of this article, and shall also include other genera of a similar character; and I do this for the simple, yet sufficient, reason, that of rendering the essays complete and useful to every class of readers. That the genus *Dacrydium* is too tender to bear the open air is, I fear, too certain a fact; but the species are admirably adapted to ornament a conservatory or winter garden, either planted out in the borders, or grown in pots. In either case, they should be grown in pure, strong loam, well drained.

DACRYDIUM CUPRESSINUM (Cypress-like D.), from New Zealand, where it is called by Europeans the New Zealand Spruce Fir. Dr. Solander first discovered this tree when accompanying Captain Cook on his first voyage. That attentive commander, in order to prevent the attacks of that scourge of sailors, the scurvy, made from this tree a kind of spruce-beer, but found it so very astringent, that he was obliged, in order to prevent the bad effects of this quality, to mix it with a tea made of the tea-plant of that country (the *Leptospermum scoparium*). This species was found on the sides of the hills, and also on the sea-coast nearly down to the water. The trees were tall and slender, reaching nearly one hundred feet in height, whilst the stems seldom exceeded three feet in diameter. This disproportion, however, was not seen, because the stems were hid by wide-spreading, drooping branches. The wood is hard, more so than any other resin-bearing trees in that country, and is beautifully variegated with white and red.

DACRYDIUM ELATUM (Tall D.).—This is the *Juniperus rigida* of Dr. Wallich, and the *J. elata* of Roxburgh. It is a native of Pulo-Penang. The tree attains a great height, and is very ornamental. Introduced about 1830, but is yet rather scarce.

DACRYDIUM FRANKLANDII *syn.* *D. HUONENSE* (Huon Pine), found in a district of that name in Tasmania. This is a valuable tree in that country; the timber is used for ship-building and other purposes. Mr. James Backhouse, the nurseryman at York, travelled through that part of the world, and wrote a very interesting "Narrative of a Visit to the Australian Colonies," and describes this tree to be large, and of a pyramidal form, growing to the height of a hundred feet, with a trunk

twenty-five feet in circumference. The branches from the trunk are nearly horizontal, and are clothed with numerous, slender, pendant, scaly branchlets, of a lively green, serving the purpose of leaves, as is the case with the Cypress and Arbor Vitæ. The wood is close-grained and more durable than the White American Pine, and has an aromatic smell. There are some specimens of this very handsome Pine in the greenhouse at Kew that have attained the height of five feet in pots. If they were planted out in a large, lofty conservatory, they would rival in beauty the beautiful *Araucaria excelsa*. The plant strikes easily from cuttings, and is now to be found in most of the nurseries near London.

DACRYDIUM MAI (Mai D.), so named by Mr. Cunningham, who discovered it in New Zealand. Very little is known about this species, though it is, I believe, in Messrs. Knight and Perry's unique collection of these interesting plants.

DAMMARA.—The Dammer, or Amboyna Pine, a very remarkable genus, but, like the preceding one, not quite hardy in this country. The genus differs from other Coniferæ in its leaves, which are broad and long, like a more common deciduous tree. The name, Dammara, is derived from the Malay language, the word being applied by the natives to the resin the plant (*D. orientalis*) produces. This resin is very curious; it is transparent as crystal, and hangs from the trees like icicles, a foot long, and three or four inches broad. It is much prized by the natives, and used as incense. The trees attain the height of eighty feet.

DAMMARA ORIENTALIS (Eastern Dammer Pine, or Amboyna Pitch-Tree).

DAMMARA AUSTRALIS (Southern Dammer, or Courie Pine).—This is a tree that strikes Europeans with surprise in its native woods, where it grows seventy feet without a branch. This peculiarity renders the timber valuable from the absence of knots; and added to that is the fact, that the timber is excellent. It produces, also, resin as abundantly as the eastern species, and is, besides, much hardier. In the warmer parts of Europe, this tree, on account of its valuable properties, should be planted largely; but in this country we must be content to admire its beauty in our lofty conservatories.

FRENELA (Meaning unknown).—This genus was established by Mirbel, and is used by Messrs. Knight and Perry in their excellent Synopsis of Coniferous Plants, to which I am largely indebted for many facts on this interesting tribe of trees.

FRENELA AUSTRALIS, *Cupressus Australis* in *The Cottage Gardeners' Dictionary* (The Southern, or Oyster Bay Pine).—This tree is found on the eastern coast of Tasmania, better known as Van Diemen's Land. Mr. Backhouse says, that though the tree is small, seldom exceeding fifty feet high, yet it is useful for building purposes, and has an aromatic smell. It is the *Thuja Australis* of Desfontaines.

FRENELA CUPRESSIFORMIS (Cypress-like F.).—New Holland.

FRENELA FOTHERGILLII (Fothergill's F.).—Native of New Holland.

FRENELA MACROSTACHYA (Long-spiked F.).—New Holland.

FRENELA TRIQUETRA (Three-sided F.).—New Holland.

All these are greenhouse or conservatory plants, though some of them have lived for some years in the south of England and north of Ireland without protection. They are singular, curious trees, having much the appearance of the common Equisetum or Mare's-tail of our swamps, magnified into trees. They are all easily grown in sandy-peat and loam, and propagated by cuttings.

T. APPLEBY.

(To be continued.)

ON THE FORMATION OF SUBURBAN GARDENS.

It very often happens that a space of more or less extent is found at the sides or back of many of our villa, or suburban houses, which the taste of the owner would be glad to see converted into something useful. I do not here mean those "front gardens," about the laying-out of which so much difference of opinion is abroad, but those slips or yards at the less exposed sides of the house; and which, though often hemmed in with buildings, are yet free from that incessant traffic which marks the "kitchen or stable yard:" in fact, I mean those snug out-of-the-way corners, where the ordinary business of the household brings but few trespassers. Many of these little spots are highly cultivated, and afford the occupant many a pleasant hour, when the stern business of city concerns are over for the day; while, on the other hand, we have been pained to see the evil effects of attempting too much on such little spots. It is in vain to think of making a park out of a pocket-handkerchief; and it is equally vain to think of growing many of the more cumbrous vegetables on a spot not much larger than a dining-room carpet. In vain does the anxious proprietor (in the afternoons when he returns from the scene of his city labours) look for the smaller vegetables and other crops, progressing under a heavy load of scarlet runners, or "Somebody's" tall marrow peas, which he was induced to buy and plant upon the authority of their raiser's advertising claims. I say, in vain he may look for any thing in the shape of onions (except an elongated stem like bullrushes), where the better half of his bed is overwhelmed by the pondrous mass of scarlet runners, which his sticks have ineffectually struggled to maintain in an upright position. A similar disaster will most likely befall any small produce that may have a tall growing potato for a neighbour; and, in fact, the anxiety to obtain so much from so limited a spot leads to disappointment quite as great as that of attempting to give the few rods of ground in the "front garden" a "park-like appearance." Objects of art may be exhibited in miniature, but those of Nature can rarely be made so to conform with anything like a satisfactory result; therefore, the inexperienced suburban occupant, who has such a small plot to occupy with some of the useful productions of cultural science, must remember that the very excellent things he is accustomed to look upon in Covent Garden, and other markets, are the produce of many districts, wide apart, but which the experience of many years has proved to be the best for producing each of them in that perfection he sees so good. Though he cannot reasonably expect to equal them, yet he may grow many things to a tolerable degree of excellence, provided his soil, situation, and other things be all favourable.

Now it often happens that ground in the immediate contact with buildings has received an accession to its ordinary condition, in the shape of large quantities of earth and other materials dug out of the foundations, &c., of the surrounding structures; yet it rarely happens that those who have the care of depositing such matters have any regard at all for any future use the ground may be put to; unless, perchance, they think it a suitable place on which to pile up some more of their bricks and mortar; therefore, it is not unlikely but the amateur, when he first puts his spade in the "back yard," finds its downward progress arrested by some stone too ugly to work even into the foundation; or, it may be, the spade may be drawn up with a material clinging to it which he in vain tries to disentangle, so often does the stiff adhesive clay of the subsoil get brought to the top when there is no ultimate object in preventing its being spread there; should the latter be the case,

the amateur must, as carefully as he can, remove a great part of it, and after getting at the good soil, which for distinction I will call "natural," he must endeavour to bring that to the surface, burying a deal of the waste matter at least two feet below the surface, providing he cannot afford to take it away altogether. In this operation, be it remembered, that all opening or porous substance might with advantage be retained, and these being mixed with the clay, will produce an effect tending to its amelioration. This class of fertilizers includes all the waste mortar that can be had, chippings of stones, and bricks; and even wooden chips are not without their uses. Supposing the clay to be buried beyond the ordinary reach of cultivation, yet it is better that the subsoil should be to a certain extent porous, and the articles above-mentioned are the best of any for making it so. I have said nothing of draining, because I apprehend that the welfare of adjoining buildings had rendered that important object necessary before gardening was thought of; if not, some little difficulties may exist in the way of disposing of the water; but this can only be arrived at on the spot.

This preliminary operation being performed, it is better to wait awhile before advancing much further, if circumstances will allow of delay. Ground that has been trodden upon, and covered up beneath a mass of impenetrable matter, requires exposure to the atmosphere before it regains those fertilizing properties it held previous to its interment; and at whatever time of year the operation of raising it to the surface is performed, a more or less period of preparation is required before it be fit to support vegetation, or to afford it those nutritious juices so necessary to its support. This process is more slow in autumn than at any other period of the year; and, perhaps, it may be more active in the hottest part of the summer. The cold drying winds of spring are not without their uses, neither are the winter frosts; the last, perhaps, being the best for extracting all pernicious matter, and loosening those bands of adhesion, a loosening so essential to soils becoming fertile. Now the same rule holds good here, which we have so often laid down for the trenching or tilling of ground—it must be often done;—the rough turned-up earth, after being partially dried, or otherwise benefited by the atmosphere, &c., may be further improved by having other portions of it exposed to the action of the elements. Let it, therefore, be dug over in dry weather; or, if in winter, when its surface is partially frozen, so as to bear the treading on; and at all times avoid treading upon the dry portion during this probationary process, and by-and-by you will be rewarded by the fine condition the ground is left in; and, eventually, planting and other duties may be done; at the same time taking care that nothing be done until you have contemplated in your mind's eye the ulterior effects such planting will have. In fact, before commencing planting at all, it is better to consider where the principal and subordinate walks are to be, and any other arrangement that may be deemed advisable had better be done before any extensive cropping be gone into; and first of all, the wall-trees, if there be any intended, might be planted, and the walk, edging, &c. formed, and other work done which may be properly called the foundation of the whole plan, and, like every other foundation, supports and maintains the whole superstructure; it is, therefore, imperative that it be good, and that nothing be introduced calculated to mar the affair; but as the subject is one deserving particular attention, I will append some more observations next week.

J. ROBSON.

WILLIAM AND ANN JONES.

By the Authoress of "My Flowers," &c.

"REMEMBER, remember, that thou keep holy the Sabbath day." Who among us remembers this as we ought? Those who most diligently seek to honour the Sabbath will be the most ready to confess that they come short of this strong and remarkable command. They will feel most deeply the requirements of God's holy law, and their own forgetfulness; how must it then really be with those who neither remember the charge, nor mourn over their guilty disregard of it?

It is wholesome and instructive to mark the dealings of God with men, in judgment as well as in mercy—not in the spirit of uncharitableness, but as warnings and calls to ourselves, to take heed lest we fall into the same condemnation, and to glorify our merciful God because He hath *hitherto* spared us.

William and Ann Jones have lived, with a young family growing up around them, "without God in the world." They have always been respectable, hard-working, well-behaved, honest people, and, therefore, the world thought well of them; but still, when we live in quiet, respectable defiance of God's commands, we are living without Him in the world. William Jones did sometimes go to church, to be sure, but very seldom, and his wife *never*. She lived for years at the churchyard gate, within fifty yards of the free sittings, but she never went in. She had a large family, a baby, little children to look after; she could go out to work in the fields very often indeed, but somehow, on Sundays, her cottage and her children could not be left; she had a great deal to do. It was very strange, but so it was; and she remained contentedly at home.

A lady who had known Jones and his wife from their being little children, and had a great regard for them, always employed Ann about her pretty cottage, and engaged her as a kind of "unattached" servant, to come and be useful whenever she was wanted, and a very honest creature she was; but this lady strove in vain to persuade her to keep holy the Sabbath day, and go to church. She warned, exhorted, and reasoned, but all in vain. The heart was not in Ann Jones to honour the Sabbath, and she civilly listened, but did her own way after all. Her mistress would not turn her away because of her guilty obstinacy, for she hoped in time to prevail; and she knew that more was to be done while she had influence over her than if she wholly gave her up; but she very often spoke very seriously to her, and pressed the subject home where a mother always feels it most.

"You will be punished in your children, Ann; some judgment will certainly come upon you for your determined refusal to go to church. Depend upon it the day will come when you will bitterly feel it; you have no excuse: your eldest girl can mind the children when you are out at work, and therefore once on the Sunday she might mind them while you are worshipping God."

No; Ann Jones liked to earn money, and there was no pay at the church door. She served her mistress well, because she knew her, and felt her kindness in a thousand ways: she saw and touched the money, the clothes, the broth, the gruel, &c., that she received from the arm of flesh; but she "knew not God," nor noticed the blessings He showered down upon her, and therefore she did not care to serve Him, or to go into His presence. She made His day a day of business, that she might make her own days days of gain, and went on very quietly and contentedly in her sin. One of the little boys was placed as cowboy to a neighbouring farmer, who was a steady attendant at church himself, with all his family, but who forgot, or did not consider, that he was bid to "remember" that his *servants* also should keep holy the Sabbath day; so little Willy spent *one whole year*, Sabbaths and week-days, in the midst of his cows, and was never for that whole time sent once to church.

One day, about a month ago, we suddenly heard that one of Jones' little boys was dead. Scarlet fever had attacked the child, and in a very few days he was taken from them. Before the funeral took place, another sickened and died. The third who was struck with the disease was poor little Willy, who had on that very Sunday, through the strong representations of a lady, been sent for the first time to

church; but he left his cows that day for ever, and his place knew him no more! He recovered, indeed, of the fever, and another child sickened and died while Willy was getting well; but just as he began to creep again out-of-doors, and gain strength, his body began to swell, and his mother ignorantly and obstinately disregarded the doctor's directions, until too late to save her child; and poor little Willy is now laid beside the sister and brothers who have gone before him. The poor mother is almost stunned with the force of these repeated visitations; four times within the month has the bell tolled for her; four times has death entered her dwelling; four times has the voice of the Lord sounded in her ears. Of the five children that lived at home, the baby in arms only is left; and the stillness—the solemn, terrible silence of that once noisy cottage—must agonise the hearts of the bereaved parents: it must cry louder than any earthly warning, “Hear the rod, and who hath appointed it.”

Little can be said to Jones and his wife as yet. The house is infected, and unsafe; and it needs more than a hasty passing moment to say all that can be said on such an occasion. But if this heavy chastening does not touch and teach the heart; if they “pull away the shoulder,” and “will none of God's reproof,” what can man's feeble word do for them? *This* is no light matter, easy to be misunderstood; this is no trifling circumstance, that seems to need man's hand to drive it home: it is a loud and terrible call from God's own mouth—a sharp and terrible blow from God's own hand—can they refuse to hear and understand it?

“Whether they will hear, or whether they will forbear,” let my cottage readers, yea, readers of *all degrees*, harken. This is a call; a cry to us. What are we doing on the Sabbath? We may not be minding our children, or cleaning our houses, or secretly washing our clothes; but are we *keeping it holy*? Are we “doing our own ways,” “finding our own pleasure,” “speaking our own words,” on that holy day? Are we going to church in the morning, and doing our own business the rest of the day, if we *do* go to church at all? Are we not “Jones's” in our different ways and different spheres? The letter written; the worldly book, the newspaper, read; the journey or the excursion taken; the light, thoughtless, worldly conversation indulged in; the visit paid or received, are “our own ways,” “pleasures,” and “words,” quite as much as cleaning and washing our clothes and houses. Who among us are altogether guiltless in this matter? Who among us remember that the Sabbath is declared by the Lord to be “a sign between me and you, throughout your generations: that ye may know that I am the Lord that doth sanctify you.” Who among us hallows it as it ought to be hallowed? Who among us “remembers” what the Word of the Lord hath spoken.

Let us all take home to our hearts the affliction that has fallen upon William and Ann Jones, the chastening they have received, and lay our hands upon our mouths. The rod may fall next, if it has not already done so, upon ourselves. Let us walk so that our God may visit us in mercy, and not in judgment; for self-condemnation sharpens and poisons the arrow that enters the heart. Let us remember the words of Him, our Redeemer, who came to seek and save that which was lost: “Those eighteen upon whom the tower of Siloam fell and slew them, think ye they were sinners above all men that dwelt in Jerusalem? I tell you nay: but except ye repent, ye shall all likewise perish.”

WILD BEES.

By H. W. Newman, Esq.

(Continued from page 52.)

APIS MUSCORUM, OR MOSS CARDER.

THE queen mother of this species is not so large as that of the others I have described, and she is the latest of the *Bombinatrices* in appearing in the spring. Her colour is pale yellow, very nearly the same as the moss in which she makes her nest, the body is hairy, the proboscis long, legs black; the abdomen of the male is longer than that of the female. The worker becomes cinereous as it gets older. This species is very easily taken, as they make their nest on the surface of the moss, and in most cases removed from the tread of cattle, in some quiet bank, or retired spot with a

southern aspect. One single queen commences a colony, which, in general, is few in number, although in favourable situations in Scotland, where the wild flowers of their seeking abound, I have found two hundred in number, and from that down to twenty, or even ten. This is a good species for watching the operations of the queen bee. I have easily taken many of their nests, the same way as the last described. The more cultivated and rich the country, the fewer bees of this species are found, and they vary in colour. In Scotland they are of a much darker yellow, and are called the *foggy-bee*, from *moss* being called *fog*, in that part of the kingdom.

When shooting on the Moors, in August, I have found the nest of this species very weak in numbers; sometimes only three or four workers besides the queen; one wonders how they exist in such a miserable locality; however, there they may be seen, booming along, and in a very calm day their hum is the only sound heard except the whirr of the Moorcock. When a boy, I had many colonies of these insects in my garden, and have watched their habits, which I can inform my readers are precisely the same as those already described, at least as to the males adopting a voluntary banishment and never returning to their nest. Excepting to an habitual observer, this is the most difficult species to watch, as the difference in colour and appearance is less than in any others between the workers and drones; the antennae of the latter are large, and a little curved, like a cow's-horn.

In an old orchard overgrown with moss, in Northamptonshire, I found at least twenty of their nests in the space of twenty yards square; no cattle had been in it, as it adjoined a kitchen garden, nor had there been any carts or waggons there. I had some difficulty myself to walk without treading on their nests, which may be known by being a little raised above the surface, and the moss a lighter colour. These bees are fond of the wildest of all wild flowers; they fly very near the earth, but have a very straight flight; they may be seen on the wild flowers in the deepest vallies and woods, as well as on the highest hills, and they are by far the hardiest and strongest of all their congeners. I have seen them, in most stormy weather, winging their way from flower to flower, at a time when no other bee could be seen to brave the wind and rain.

The male of this species is the latest of all in appearance, at least in our climate, seldom appearing before the end of August or beginning of September, and may be distinguished by his low flight along hedgerows, and his stopping frequently as if intending to go into the ground; this he will continue for a mile together, and, if watched, he will be seen to return to the same places more than ten times in an hour! There are two or three varieties of the *Apis Muscorum*, one of which the workers are good sized bees, with scarcely any small ones in the nest; these inhabit the West of England. I found that it does not answer the end to examine the nest of the Carders often. I found a strong nest in Northamptonshire, a few years since, and examined it repeatedly by breaking the moss; at last, a young friend of mine, wishing to have it in his garden, we went one night to take it, and discovered about one thousand ants in possession of the combs, and all the bees gone. The ants had got through the moss where it was broken and unguarded, and had overpowered the bees.

Should any of my readers wish to make experiments on any species of these insects, they should choose the end of July or beginning of August, or, if a dry, hot summer, a fortnight earlier. By far the most interesting of the species I have described are the *Apis Lucorum* and *Lapidariae*. The males of each of these are beautiful in their colours, and easily distinguished from the workers. The love of their offspring is strongly developed in all these insects. When first I took their nests, the only combs I robbed them of were those containing honey, being, like a true boy, fond of sweets; the bees that I brought with these combs generally emptied the cells and deserted them. I afterwards found that whenever I took the combs containing *young brood* in embryo, this was never the case.

(To be continued.)

COCHINS, DORKINGS, AND SPANISH.

I HAVE read the correspondence which has appeared in your paper, on the relative merits of the Cochins-China, Dorking, and Spanish fowls, with interest and amusement, not unmingled with instruction. While this discussion shows, beyond doubt, how much the interest felt upon this subject is increasing, its appearance in the columns of your little publication equally proves that we are to look, for the future, upon THE COTTAGE GARDENER as the medium of inter-communication between poultry-fanciers.

The important question is, as it seems to me, which of the varieties named is the most useful and the most profitable—and its solution depends upon several considerations. The man, for instance, who should declare, *ex cathedra*, that the race-horse is superior to the cart-horse, merely because he can gallop round him; and he who, on the other hand, should decide that the cart-horse is more useful than the racer, merely because he can draw a greater weight, are equally wrong in their judgment, or equally unfit to form an opinion. They are of different varieties, and the question being, which is the best, its true answer is, that which combines in itself the greatest number of good points with the fewest bad ones.

Taking this to be the real question in controversy among your correspondents, I request permission to state the result of my experience; for it is only by such friendly discussions as these that facts are elicited, opinions compared, and moot points satisfactorily cleared up. And, first, it is right that I should state that I am an old fancier, and have acted as judge at different Exhibitions; that I have kept Spanish fowls for many years; that an intimate friend of mine keeps nothing but Dorkings, and I have access to his poultry-yard as freely as to my own; and that I have kept Cochins, besides my Spanish, for about four years. These, and what I have had the opportunity of observing of all the breeds in the yards of many fanciers of my acquaintance, are my means of forming a judgment of the relative merits of the varieties in question.

In the next place, I apprehend that the useful and the profitable are made up of the following points:—Which are the most prolific; which the best mothers and nurses; which are the most easily reared, and attain maturity the earliest; and which are the most valuable when that maturity is reached. I propose to touch, shortly, upon each of these points *seriatim*. First, then, which of the three varieties is the most prolific? This question divides itself into two. If we look at eggs alone, the *Spanish*, though the smallest hen of the three, lays, undoubtedly, the *largest* egg. In my opinion, she lays as many of them as the *Cochin*, and consequently a greater weight in the whole, but she never sits. The *Cochin* is, undoubtedly, as "*Gallus*" candidly admits, far superior to the Dorking as a layer, and lays during a much longer period of the year, and she has this superiority over even the *Spanish*, that she lays better during the winter months, when fresh eggs are most valuable.

As regards the hatching of the eggs, the *Cochins*, in my opinion, beat both their competitors hollow. There are fewer bad eggs in proportion to the number set, and the chickens come out stronger than those of either of the other varieties. As mothers and nurses, the *Spanish*, as I have said, do not enter into the competition. The *Dorkings* are good in both respects; but I am inclined to award the palm to the *Cochins*, on account of their soft and fluffy down, and the extreme quietness and gentleness of their disposition; and they begin to lay again sooner than any other fowl. I am also most decidedly of opinion, that of all the chickens I know, none are so easily reared as the *Cochins*. The qualities of the mother, to which I have just alluded, contribute, no doubt, to this result; but even under mothers of other breeds (of which, however, I by no means recommend the use, where *Cochin* mothers are to be had) I have found them easier to rear than either *Spanish* or *Dorkings*. Between the two last-mentioned varieties, I am somewhat at a loss to decide this point, but on the whole, I think the *Spanish* perhaps less delicate in constitution than the *Dorkings*. Out of 120 *Cochin* chickens hatched this year, by *Cochin* mothers (of which I kept some inferior ones for the purpose), I did not lose more than half-a-dozen.

I have never been anything like so fortunate with my *Spanish*, nor has my neighbour with his *Dorkings*.

As regards early maturity, the *Cochins* and *Dorkings* are both superior to the *Spanish*, and I believe the *Cochins* beat the *Dorkings* too. On the 3rd of June, some chickens, weighing above five pounds each, were shown at Cheltenham, if I recollect right, by Mr. Lawton, of York; and I myself killed, in July, a cockerel hatched in March, which weighed (dead) nearly six pounds. I have never seen or heard of any *Dorkings* which attained those weights in the same length of time, and certainly *Spanish* will not do so. As table fowl, for roasting, I think there is very little difference between the three varieties, in point of quality. Fed alike, their flesh is equally good in flavour, and, no doubt, equally nutritious. But for boiling, I agree with the poulterers, that the *Dorkings* are the best, because they are the whitest in the skin, and in the leg; and this delicate white appearance is, no doubt, one reason for their selling best in the market, as Mr. Bailey says they do.

On the whole, my deliberate conviction is, that the *Cochins* will be found the most useful, and (for all purposes) the most profitable of any variety of domestic poultry yet known in this country. I have no prejudice in this matter, having good *Spanish*, as well as good *Cochins*, of my own, and the means of obtaining good *Dorkings* by the asking for; and, indeed, I was so far prepossessed in favour of the *Spaniards*, from having kept them so long, and taken so much pains to procure the best of them, that I have not yet given them up, nor do I intend doing so; and I have only given my verdict in favour of their rivals because my judgment compels me to do so. I must, however, be understood to refer to the short-legged, compact breeds of *Cochins*, and not to the coarser varieties; in fact, to compare the best of the one with the best of the other breeds.

There are some minor points which it may be well to notice, lest I should be thought to have overlooked them.

The *Cochins* are, of all fowls, the most "domestic," and the easiest to keep at home. A fence of the height of three feet will confine them; they are tractable and quiet to a degree, and are neat and pretty in their appearance. I do not at all agree with some of your correspondents, that they are greater eaters than other fowls in proportion to their weight. The farmer does not expect to feed a large *Short-horn* with the same quantity of provender that will suffice for a little *Scot*. And I am of opinion, after repeated trials, near enough to convince both my servant and myself, although not so nicely made as to justify me in giving exact weights, that, allowing for the extra size, neither old nor young *Cochins* consume more food than *Spanish* (and ducks, by the way, beat both hollow).

With regard to present estimation and value, there cannot be two opinions. To say nothing of some few extra specimens, scores of *Cochins* were sold this year, to my knowledge, at £5 each, and hundreds at £2 and £3; and I shall not be surprised if some of Mr. Sturgeon's birds bring, at his sale next week, greater prices than these. There were, undoubtedly, poultry shows, and good ones, before *Cochins* were introduced into this country; but what would our shows now be without them? Every one, I think, will admit that, in these days, the principal classes—those which attract most attention, and excite the keenest competition amongst amateurs—are the *Cochins*. This may, to some extent, wear off, as they get more common (although I cannot say I expect it); but, depend upon it, good birds will always command remunerative prices, and greater ones than either *Spanish* or *Dorkings* ever fetched, although a first-rate *Spanish* or *Dorking* fowl will still bring a good price; and I repeat that I by no means wish to be understood as intending to depreciate them when I say I prefer the *Cochins*. The latter have, undoubtedly, taken a position which, in my humble opinion, their merits will sustain for them; and this is the test of their value.

That I am not singular in the estimate I have formed, the correspondence already published by you sufficiently shows. In further corroboration of it, I refer you to the following extract from a Canadian paper (published at Toronto):—

"On looking over the list of premiums offered by the 'Agricultural Society' for the next month, I was much surprised by finding so little attention paid to a 'class' which

needs improvement here perhaps more than in any other country. I allude to poultry.

"The committee place at the head of this class, 'Dorkings' (without saying whether 'white' or 'spangled')—then follow 'Polands,' and lastly 'Large Breed'—what the 'Large Breed' may be, it is impossible to say. Surely the managers are sadly behind the age in knowledge of poultry, if they are not aware, that there are many varieties of fowls superior to the 'Dorking' and 'Poland.' The Dorking is no doubt a fine bird, as compared with the common, little, miserable objects usually sold in our markets, called 'chickens,' and possesses many good qualities—and the Poland has beauty of appearance, as well as fertility of eggs to recommend it, but into what insignificance they creep when placed near any of the Cochin-China, or Shanghai varieties. There are two families from Cochin-China,—the 'Royal,' and 'Imperial;' four, from Shanghai, the Black, White, Buff, and Brown, all of which are superior to the Dorking and Poland, in the following qualities:—First, size; second, quality of flesh; third, number of eggs; fourth, fertility of egg; fifth, hardihood of chickens; sixth, better nurses; and seventhly, value of feathers (nearly as valuable as those of geese). Add to all this, they have borne our winters, even better than our common fowls have done, and surely any person who has ever seen one of these magnificent birds could scarcely pass them over without notice.

"I have mentioned 'Shanghai's' and Cochin-China's because I am more familiar with them, than other foreign varieties, but there are other birds which have their champions; say 'Brahma Pootra' (26 lbs. the pair), 'Great Java,' 'Plymouth Rock' (18 lbs. the pair), 'Black Spanish' (superior to Poland in weight, and lay quite as well), and many others which we ought to know more about, a knowledge which can easily be obtained by a perusal of an excellent work lately published at Boston, called 'Dixon and Kerr's Ornamental and Domestic Poultry Book'—a work as superior to our old-fashioned poultry books as an 'Imperial Cochin cock' is to a half-bred Bantam."

This statement is especially valuable as bearing testimony that the Cochins will bear even a Canadian winter "better than our common fowls," and before I quit it, I will add, that I shall be much obliged to any of your correspondents who can give any information respecting the other large varieties of poultry mentioned in it, or who can tell me whether "Dixon and Kerr's Poultry Book" can be had in this country.

You will have observed that I have said nothing respecting the different varieties of Cochins; this, as you are aware, will appear in another form. In conclusion, I would add my caution to that of Mr. Wingfield (to whom, and to "Gallus," I feel much indebted for their contributions to your paper)—"to avoid all crossing." A first cross will do for the spit, but after that they soon degenerate into downright mongrels.—COCHIN.

EXPENSE OF FEEDING COCHIN-CHINA FOWLS.

JUST as I am sending off to you the result of another week's trial of the relative quantities of food consumed by Cochin-Chinas and Spanish, I read (in THE COTTAGE GARDENER of October 21st)

"The strain of strutting chanticleer
Cry Cock-a-doodle-doo!"

And I may as well answer it with the words preceding these lines, *Bow! wow!* of which there is a good deal in Mr. Cock-a-doodle-doo's paper. Let me remind *him*, and "Q-in-the-corner" too, whose answer, by-the-by, is much more (to my mind) to the purpose than poor dear Cocky's, that I have never brought into my arguments the words, which they both use—"in proportion to their size." I have nothing to do "with proportion to size." I have been discussing Cochins, as to whether they are the best fowls to keep altogether, or not, taking into consideration their merits (to which I have never been blind), and their fault of "being such large consumers of

food," which fact I can neither be written nor persuaded out of, for I have proved it, not only to my own satisfaction, but to that of every unprejudiced or uninterested person.

As an eating fowl, a Dorking *must* always be its superior. It can be got up to the same weight (even saying nothing as to flavour, and "white meat," when cooked) at a less expense than the Cochin. Surely, then, where chickens are in demand, it is a more paying fowl to the cottager.

As a layer, if a Spanish fowl, at a cost of twopence a week, can produce, say (by way of argument) five eggs, weighing 16 oz., against six eggs from the Cochin-China, weighing 12 oz., but at a cost of fourpence a week,—I leave it to the cottager to say which (if he wants eggs) will suit his pocket best.

I have been told by Anster Bonn, and others, that Cochin-Chinas "did not eat more than other fowls." Now, however, the ground is changed, and "proportion to size" comes into play. I therefore presume it is beginning to be allowed that "they do eat more than others;" and common sense may well (like the Irish echo) answer, "they do." The Cochin-China supporters have injured their own cause, in their over eagerness, by asserting too much. It is not to be supposed that large fowls, coming early into maturity, attaining great size, and laying a great many eggs, can consume as little as smaller hens, who do not equal them in some of these respects.

An old man, a great lover of poultry, asked leave, a few days ago, to see what he called "my new-fashioned poultry." His remark—"Well, Sir, if you do gets many eggs from them chaps' bodies, you *mun* put a lot of grub in their bellies"—is, I believe, quite true.

Your Cochin-China correspondents seem to be ignorant that I am a Cochin-China fancier myself, as well as they; and I may assert that I am very fond of them, but I cannot go all their lengths, and declare there is nothing like them.

This is the last letter I shall write to you on the subject. I shall retire to my perch, satisfied that time and trial will prove me not very wrong; and when I hear of Cochin-Chinas changing hands, as they are now doing—and when I am told, as I have been by an eminent Cochin-China fancier, that "It's time to get out of it," and see many such letters as some I published in my last paper to you—I begin to think I see a "something looming in the future," and that the "old uns," like rats (I do not mean this simile disrespectfully), are leaving a falling house.*

Now, sir, for the trials, which were conducted under exactly the same circumstances as the others, except that only the cock and one hen were left in No. 1, and that, though the cock in No. 2 was the same, the hens were different, but *about* the same age. As to the accuracy of the account, I pledge you my word. It may be said, my feeding is extravagant. I can only say, I went into a farm-house to-day, where they pride themselves on their poultry, and found them mixing a large tub of meal and steamed potatoes for some fine Minorca hens.

You see that similar results are again obtained—the Cochins eating double what the Spanish (and other fowls, which I will name) have done.

I have been told—"Oh! your climate certainly sharpens your fowls' appetites;" but what is food for the goose is food for the gander, and the climate that tells on the Cochin will tell on the Spanish; and the fact remains the same—"That the quantity and cost of food consumed by one is about double that of the other."

A friend of mine, who keeps only Bolton Greys, who has been trying the experiment for me of their eating, reports the result to me as "not quite twopence a week," but he does not send me the quantities. A similar report of a Golden-spangled Hamburg fancier is "about twopence a week." My own impression had been, that, as consumers, fowls might thus be classed:—

Cochins.
Dorkings.
Spanish.

And I fancied that Bolton Greys, &c., ate less than Spanish. This does not appear to be the case; and a man who keeps

* If "Gallus" alludes to the sales of part of Mr. Sturgeon's and of Mr. Andrews' stocks, we think it may prevent misunderstanding to state, that both those gentlemen are pursuing the exclusive breeding of Cochins as ardently as ever.—ED. C. G.

Spanish, and Bantams, told me he thought the latter ate as much as the former. I am inclined to differ from him. I enclose you an extract from an amateur, who, perhaps, knows more of Dorkings than anybody in England.

"I shall not be able to send you yet an exact account of what my Dorkings eat. My opinion is threepence a week, and I am almost sure you cannot do them for less. They may be kept alive for less, but not in condition. I find, on comparing my account for January, February, March, and April, that my twenty-one fowls (having the advantage of a good run, so far as herbage and casual food are concerned) cost me regularly £1 for four weeks all this time." So much for a penny a week! I have liberated my fowls now, as I consider my experiments conclusive; but if your readers are not of this opinion, only let them follow my advice of weighing out a pound of wheat or barley, and seeing how long a Cochin-China hen will be in gobbling it up. But if I can be taught how to feed my fowls well (for I am sure, not to feed them really well is no economy), I am poor enough to gladly save some money, and young enough to be willing to learn.

In taking leave, as an author, of the pages of THE COTTAGE GARDENER, I can conscientiously affirm that (having no object to gain) I have only stated what I believe to be strictly true, the result of my own experience, and that of others; and in thanking you for the courtesy and attention I have received from you.—GALLUS.

Time of Experiment—Oct. 11 to Oct. 18.

Lots	Description	Age	Weight		Quantity of food consumed	Cost		No. of eggs	Weight of eggs			
			Oct. 11	Oct. 18		Weekly average	oz.					
1	Cochin-China Cock	1851	Not weighed.	Not weighed.	lb. oz.	d.	4	1	2			
	Cochin-China Hen	1851			Meal 3 1	3						
					Bran 0 15	1						
					Corn 3 14	3						
					7 14	8						
2	Cochin-China Cock	1851	Not weighed.	Not weighed.	Meal 3 12	4	3	4	8			
	Cochin-China Hen	1851			Bran 1 0	6						
	Cochin-China Hen	1851			Corn 6 0	6						
					10 12	11						
3	Cochin-China Cockerel	1852	Not weighed.	Not weighed.	Meal 4 0	s. d.	4					
	Ditto ditto	April			8 4	8 13				Corn 14 0	1 2	
	Ditto ditto	June			8 8	8 12				7 9	7 10	Pota-
	Ditto ditto	June			7 9	7 12				toes 5 0	2	
	Ditto ditto	June			5 12	6 0				23 0	1 9	

Time of Experiment—Oct. 14 to Oct. 21.

Lots	Description	Age	Weight		Quantity of food consumed	Cost		No. of eggs	Weight of eggs		
			Oct. 14	Oct. 21		Weekly average	oz.				
4	Spanish Cock	1850	Not weighed.	Not weighed.	Meal 5 0	0 6	2	2	2		
	Spanish Hen	1850								Corn 19 0	1 7
	Spanish Hen	1850								Bran 3 0	0 1
	Spanish Hen	1850									
	Spanish Hen	1850									
	Spanish Hen	1850									
	Spanish Cockerel	1852									
	Spanish Cockerel	1852									
	Spanish Cockerel	1852									
	Spanish Pullet	1852									
	Spanish Pullet	1852									
	Spanish Pullet	1852									

FUCHSIAS.

I FEEL disgusted at *Fuchsia spectabilis* being classed with its more handsome neighbours, for there is no beauty in it or of it. A friend of mine has had one for this three years, and it has got to the height of nine feet, without gratifying the cultivator with one of its flowers. *Fulgens multiflora* is far in advance of it. Many advise that the plants which flowered in autumn should be allowed to grow all winter; but that would not do for the cottager, or even for our practical men, for all the nursing that you can give them, the season of rest will not pass over without some defect on the plant's system, for nature will not be robbed of the rest. My plants, which have done flowering, and which I mean to flower next May and June, I have placed in their winter quarters, under the greenhouse shelves, taking care to lay

the pots on one side. This prevents the worms from intruding, and likewise keeps the pots from getting too wet, which would start them into unnatural growth, and so weaken the system of the plant. To do them justice, you should have two sets of plants, one for early-flowering, and the other for late-flowering, so by that means you may secure their blooming from May till November. In the spring, I usually take cuttings at the time I start my plants into growth; taking care to strike these in a nice, moist, dung-bed. By taking cuttings early, and keeping them potted, they will repay the cultivator for all the labour bestowed on them. The compost that I generally use is composed of one-and-a-half maiden loam, one-quarter leaf mould, and one-and-a-quarter what is termed yellow loam, from Wanstead. In this they not only grow vigorously, but retain that glossy foliage which imparts to them that contrast of flower and leaf which is so characteristic. When the plants are in a fast-growing condition, it is a great assistance to water them, say twice in the week, with a liquid-manure of sheep's dung. This makes a great addition to the size of the flowers.

In my rambles to-day I came across that much-noised-about *Fuchsia*, *Batten's Pagoda*. There is something novel in the colour of the flower, but as for showing purposes it is quite worthless; the tube is something in the shape of *Goliah*; the sepals not reflexing, and the corolla something in the shape of a soda-water bottle, never expanding at all; still, for its colour, it might have a place in a collection; but I should advise the amateur, before he buys, to see it in flower, and judge for himself. If he goes to the show-rooms, on the show days, he will be able to pick for himself. We are getting three distinct classes of *Fuchsias*. *First* is crimson with violet. *Second*, white with scarlet. *Third*, white with violet purple. The latter we have been wanting much. The following is a list of specimens of the three classes that I think would not discourage the buyer, nor disgrace the seller.

- 1.—*Alpha*; tube and vessels red, reflexes well, corolla rosy-purple.
Clapton Hero; tube and vessels glossy crimson, corolla purple.
Dr. Smith; bright crimson, with violet corolla.
Kossuth; bright crimson, violet corolla.
Resplendens; crimson-red.
Nil Desperandum; waxy bright scarlet, corolla violet-purple.
Don Giovanni; crimson tube, and sepals rosy, purple corolla.
- 2.—*Princess*; white, with scarlet corolla.
Bride; white, with vermilion corolla.
Elizabeth; blush tube, corolla rosy-purple.
Expansion; white, corolla bright rose.
Joan of Arc; white, corolla rosy-scarlet.
Conspicua; white, with vermilion corolla.
Pearl of England; blush-white, corolla scarlet.
- 3.—*Sidonia*; blush-white, with violet-purple corolla.
Sidonia superba; white, violet-purple corolla.
Delicata; white, with bright purple corolla.

R. WEATHERILL.

CEANOTHUS AZUREUS.

SEEING this beautiful climbing shrub mentioned in your notice to correspondents this week, and not remembering to have seen the culture of it in THE COTTAGE GARDENER, I am induced to send you a few lines upon it. First, as to soil. I find it likes a light garden soil, not too rich, with a little peat to start it. Secondly, as to situation. A wall facing the south; and, thirdly, as to its propagation. It can be raised from seeds, which it produces very freely. Sow them in shallow pans, in three parts peat, one part loam, and one part of well-rottened turf, with a little silver sand to keep it open. Let the pans be well drained, and placed in a cold frame or pit. Sow at the end of February, or the beginning of March. It may also be struck from cuttings in the same frame or pit, using the same soil. To effect this, take off some nice short cuttings about Midsummer, with a little of the old bark at the base of the cuttings. Use the same soil, with a little sand on the top, and place a

bell-glass over them. (I forgot to say that the seedlings must be potted off when about three inches high.) There is also another mode to obtain plants, and which I think the best and quickest way to get a fine plant, and that is to select some of the finest shoots when the wood is moderately firm, with a good leader, and of these shoots, about from nine to twelve inches from the tip, cut a notch or slit upwards about an inch, beginning from below a joint; place in this notch a small wedge, to keep it open, and chop some moss fine, and mix with it a very small quantity of peat, not too fine; place this fine moss and peat in some longer moss, so as to keep it together, then place it round the notch, and bind it up rather tightly, but not too much so; bind it up with large worsted, or what is called wool-spun, and leave a long piece from the tie, and place over this layer, as I shall call it, a common glass bottle, by driving a large nail or hook into the wall, tying a wire or strong whip-cord round the neck of the bottle, and hanging it on the nail, filled with water, and put the end of the wool-spun into the water; this will keep the moss always moist, and when you find it has made tolerably good roots, cut it half way through from the old plant, and in a fortnight you may cut it off, and pot it, and next spring plant it out where it is to remain; protect it a little for a year or two in winter, with a mat or straw; prune it as you would a rose, that is, to about two or three eyes, but above all, do not prune it until the middle of April, or you may lose your plant.—CHARLES LEVETT.

BEE-HARVEST.—1852.

SEEING that you ask for returns from bee-keepers of their experience of this year's results, I beg to forward you the annexed tabular account of my apiary. It consisted, in the spring, of thirteen stocks in various hives, wood and straw, nearly all upon the depriving system, by means of glasses, small straw caps, and small boxes. They were numbered from 1 to 13. I consider it a very bad year, both as to swarms and the amount of honey gathered. To make a comparison, I may state that last year, from nine hives I had seventeen swarms, all of which did fairly. This year I had—

- | | | |
|------|-----|---|
| June | 1. | A swarm from No. 4. |
| " | 4. | Ditto " No. 6. |
| " | 4. | Ditto " No. 10. |
| " | 15. | A second swarm from No. 4. |
| " | 19. | A swarm, not known whence. This deserted the hive a few days afterwards. |
| " | 20. | A double swarm, viz., a first swarm from No. 7, and a second swarm from No. 6, joined together, of their own accord, on a tree at the time of swarming. |
| " | 23. | A swarm from No. 8. |

So that I have seven stocks which have not thrown off a swarm. And have only added six new stocks to my apiary. My honey-harvest has been—

- | | |
|----------|---|
| June 15. | A small wooden box, taken from the top of No. 4. Removed because it contained brood, chiefly drones. The honey in it weighed 2½ lbs. |
| July 24. | A straw cap, taken from No. 2, very rich, and thick comb. Weight 13 lbs.; of which the cap weighed 1½ lbs., honey 11½ lbs. |
| " 24. | A straw cap taken from No. 11, equally good with the above, but the cap somewhat smaller. Weight 12 lbs.; cap hardly 1½ lbs., honey, 10½ lbs. |

N.B. These caps, when well filled, are supposed to hold 10 lbs. of honey. I never before had one of the kind that exceeded that weight, so that the above two are very good specimens.

- | | |
|----------|--|
| July 24. | A straw hive, No. 10. An old hive. Gross weight 23½ lbs. Hive about 5 lbs. Good honey, cut from it free from brood and pollen, about 10 lbs. |
| " 24. | A straw hive, No. 6. An old hive. Gross weight 22 lbs. Hive about 7 lbs. Honey strained from it about 8 lbs. |
| " 30. | One of this year's swarms. Yielded of pure honey, strained, 10 lbs, I. M. |

TO CORRESPONDENTS.

* * * We request that no one will write to the departmental writers of THE COTTAGE GARDENER. It gives them unjustifiable trouble and expense. All communications should be addressed "To the Editor of the Cottage Gardener, 2, Amen Corner, Paternoster Row, London."

RE-ARRANGING WALKS IN A VILLA GARDEN (Suburban).—We do not approve of either of your plans, Figs. 1 and 3 of the walk diverging and surrounding a triangle at top; much better let it proceed up the centre, as in Fig. 2, and terminate in some ornamental object, as an arbour, summer-house, piece of sculpture, or sun-dial; but a summer-house or arbour would be most appropriate. Your space is too limited to grow many vegetables, under any circumstances; therefore, appearances ought to guide you as to its disposal. Avoid all tall things, as Asparagus, Peas, Jerusalem Artichokes, and Scarlet-runners, all of which you will buy cheaper than you can grow, and devote what space you have to lower-growing crops. A walk by the side of a wall is not necessarily injurious to the fruit-trees trained thereon, provided a suitable description of soil be afforded the roots underneath the walk, the substance of which ought to be thin. Trees often do better so treated than when a heavy vegetable crop contends with them for the uses of the border. See an article by Mr. Robson, on Suburban Gardens, in to-day's paper, which will be followed by others bearing on the same subject.

PHYTOLACCAS (T. W.).—Many thanks for the seeds of *Phytolacca decandra*, which are quite true. The plant, however, will grow full five feet high, if you can preserve it through the winter. Damp is worse for it than frost, and it is always a safe plan to grow a few from seeds every year or two. The seeds will keep better in the berries, and also on the stalks, all the winter; and about the end of February is the best time to sow them, and then to sow the berries just as they are. They want the same treatment as ridged Cucumbers, or Capsicums, or Tomatoes, and no soil can be too rich for them to flower in, and no soil can be too poor for them to stand well against the frost. Hence, to grow them to perfection, we ought to treat them as biennials. Sow them at the end of April, in a close, cold pit; nurse them in pots till July; then plant them out for six weeks; then take them up and pot them, and keep them over the winter with the *Humeas*, and next May plant an avenue, or long border, with *Humeas* and *Pocans* alternately. By so doing you will make a stir in that part of the country. Three, five, or seven plants of this *Phytolacca*, planted in a group in front of a tall mass of evergreens, in very rich soil, and at some distance from the walk, would have a splendid effect.

FLOWER-GARDEN (T. F.).—You have distributed the colours well, but the plants do not match as they ought to do for this style; 3 and 4, for instance, purple *Petunia* and blue *Lobelia*, when in their prime, will look like a carriage-horse and a Shetland poney yoked together; both in high condition, but not a match, as all pairs ought to be, whether carriage-horses, flower-beds, or flower-pots. To a practised eye, a man going down the road with a hobnailed shoe on one foot, and a tight Wellington on the other, would not look more strange than a *Petunia* and a little *Lobelia*, side-by-side, "to match!" *Salvia chamædryoides* is the nearest to suit No. 3 bed; 13 and 15 ought to change places with 11 and 12, being lower, and of better habit, next the house; 1, 2, 5, 8, 9, 10, and 14, could not be done better, and there is not a plant in the catalogue to suit No. 6, except *Cineraria amelloides*, to carry out your own way of matching in blue and purple. To exemplify all this, and as a good example of covering such a space, we shall engrave your plan some day. The *Vine* will do very well as you propose to train it, but beware of the shoots being crowded.

FLOWER-GARDEN (J. H.).—The best-shaped beds are circles; next best, ovals; third best, long, narrow beds, with some graceful curves in the outline; and the fourth best is, for you, what you think the best yourself; and so with all the world besides. In nine cases out of ten the shapes of flower-beds are determined by the size, situation, and laying-out of the piece of ground. You marked a line from the circle in front of the offices to the oval at the farthest end, a single bed placed on that line would spoil the effect of your garden, on paper, whatever the shape might be. If you could place two other circles opposite the present two, and a half-moon-shaped bed in the middle, between them, that would be right.

SCARLET-FLOWERING PEACH (R. K.).—We never say where such and such plants can be bought. We said once or twice that Mr. Appleby could get any plant that was on sale in Europe or America for anybody who offered to pay for it. The best way is to give your commission, in all such cases, to the nearest nurseryman, and he can, if he chooses, supply you with plants free of all carriage, &c., as cheap as you could buy them in London. Your bookseller does the same thing every week in the year with this COTTAGE GARDENER. Doing things in a business way, in a business country like England, is always the surest and cheapest way in the long run. We are intending to have excellent lists of all the best shrubs and trees this winter; for we can now afford space for them.

"ORCHARD" will see much of his question answered to-day, in a paper on Fruit and Vegetable Culture. The most noted counties for the *Damson* are Shropshire and Cheshire. In the part where we write (Cheshire) every cottage gardener has them blended with the thorn hedges; and many, in good seasons, pay their rent with these alone. They delight in sandy soil, although we find them occasionally growing in stiff soils. Any nurseryman, living by the rail in those counties, would supply you. Plant directly, above the ground level; use in your stiff soil some road scrapings, or loose material. To your *Apple* list add *Beauty of Kent*, *Chapel Apple* (to be had in any Lancashire nursery), *Dumelow's Seedling*, or *Normanton Wonder*. To your *Pears* add *Jersey Gratioli*, *Dunmore*, *Beurre de Capianmont*, and *Beurre Diez*. You may put the rubble between the roots, in stations formed hard, with a convex surface.

"STUPID."—Your paper will be noticed in due course.

LARGE PLANTS OF PELARGONIUM DYING OFF.—R. F. had some splendid plants of the fancy kinds last summer; dense bushes, the heads fully four feet in diameter, and a mass of bloom for four months.

They have been managed exactly as detailed in this work, and by which they have previously given great satisfaction. They were allowed to get rather dry, were pruned back as usual, broke fresh shoots moderately strong; were fresh potted, and stood still; and now several of the best of them are gone, the main stem decaying just before the skeleton of the top branched off. Now, will any of the learned say what this is owing to? We sometimes think *age*, the mass of flowers they produced, the length of time they bloomed, &c.; but then some of their neighbours underwent all these conditions exactly, and yet seem right enough. When we look on the beautiful skeletons of these defunct plants, and think what they might have been next season, when clothed with flowers and foliage, we cannot help wishing that a plant doctor, of universal curing abilities, had seen and prescribed for them. The plants were more than three years old.

CLIMBING PLANTS FOR GREENHOUSE (J. R.).—We are almost afraid to enter into detail about *Passion Flowers*, *Mundevilla suaveolens*, *Tucsonia pinnatistipula*, *Tecoma jasminoides*, &c., as considerable attention has lately been bestowed upon them. The pruning of most of them was also given. In respect to your inquiries on that subject, as the plants have not yet reached the top of the house, you may shorten the ends a little now of all, and prune in any side-shoots of the *Passion Flowers*. The *Glycine* will bloom on ripe young wood, and also on spurs, just like a currant. *Tropaeolums*, of most kinds, will die down in winter; at least, if the house is not warm they will not succeed. *T. Lobbianum* will do well in a temperature of 50°, and bloom all the winter. As to *pots*, you must proportion the size according to the space you wish the plants to occupy—say from twelve to eighteen inches in diameter. Do not shift them now, however, if these plants are in small pots; wait until the end of March. See what Mr. Fish says to-day.

DESIRABLE HARDY SHRUBS (Ibid.).—We could serve you better if you told us your purpose. The following are useful:—*Deciduous*—*Aesculus carnea* and *pavia*; *Azalea*, Ghent varieties, &c.; *Amelanchier florida*; *Andromeda buxifolia*, speciosa requires heat; *Chimonanthes fragrans*; *Calycanthus floridus*; *Cotoneaster* of kinds; *Crataegus heterophylla*, *pyrifolia*, *coccinea*; *Deutzia scabra*; *Daphne mezereum*; *Gaultheria shallon*; *Hibiscus syriacus variegatus*; *Indigofera violacea*; *Halesia tetraptera*; *Philadelphus grandiflorus*; *Pyrus spectabilis*; *Ribes sanguineum speciosum*; *Spiraea grandiflora Lindleyana*; *Symphoricarpos racemosus*; *Syringa Josikea*. *Evergreens*.—*Adesmia viscosa*; *Berberis aquifolium*, *Darwinii*, &c.; *Benthamia fragifera*; *Bupleurum fruticosum*; *Cotoneaster rotundifolia*; *Daphne cneorum*; *Helianthemum* of kinds; *Kalmia angustifolia*, &c.; *Ligustrum lucidum sempervirens*; *Yucca filamentosa superba*, &c.; *Vaccinium flore coccinea*; *Viburnum tinus*, *hirtum*, &c., with *Rhododendrons*, common and hybrid; *Magnolias*, if the station is warm and sheltered, and for beautiful ever-green effect, have such *Junipers*, *Cupressus*, and *Arbor Vitæ*, as Mr. Appleby has, and will recommend.

ONE-THOUSAND-AND-ONE QUESTIONS (John).—Put them one at a time, and we will answer them, although, if you refer to the indexes of past volumes, you will find all the information you seek. To reply to the whole at once would fill a column.

CIDER-MAKING.—*Somersetensis* will be much obliged by an account of the method of making Cider in Gloucestershire or Herefordshire. Will some of our readers favour us with a reply?

CELERY BLIGHT (A Subscriber).—The blight, or parasitical fungus, which covers both the upper and under sides of the leaves of your Celery plants, is probably one of the numerous species of either *Aecidium* or *Uredo*. Dust the leaves with a mixture of quick-lime and sulphur—two parts of the first to one part of the latter—and oblige us with a statement of the result.

NAME OF ORCHID (T. F. G.).—This, which we did not recognise from so small a piece, we find is *Tillandsia stricta*, a beautiful species from the West Indies and Brazil. You will find an account of it in our sixth volume, page 386.

FOWLS FOR EGG-PRODUCE (W. E. J.).—If you wish for fowls that seldom or never desire to sit, so that you may avoid the trouble of chicken rearing, keep the Spanish. They lay larger eggs than the Shanghai, but the latter lay quite as many in the course of the year, and will lay throughout the winter, if carefully managed. By *Shanghai* we mean what are erroneously, though usually, called *Cochin-Chinas*.

WHITE SHANGHAI FOWLS (N. J.).—They are sometimes pure white, but usually with a considerable admixture of grey feathers in their plumage. We have seen specimens of them larger than of any other colour. They are feathered on the legs. Fashion is too like a butterfly for us to say where she is likely to settle. If any one near Leeds, or York, has any of the White Shanghaes to sell, they will oblige by writing to Mr. John Noble, Boston Spa, York.

PEAT (Y. Z.).—You may apply it with advantage to your *Hydrangeas*, the flowers of which it may render blue; but to none of your other plants or crops will it be of any benefit. It is invaluable to all American plants, and we should think some florist will gladly give you manure in exchange for it.

REGULATION OF TIME.—*Expertus* and the *Rev. F. H. S.* have kindly pointed out, that in our weekly Calendar for October the clock is erroneously put as "before the sun," instead of "behind."

CAMELLIA BUDS FALLING (Emma).—The fact of your Camellias being in the dry air of your sitting-room is quite sufficient to account for this catastrophe. If the soil is wet, and the air dry, or the reverse, buds are always liable to be shed, on account of the disproportionate action of the leaves and roots.

COVENT GARDEN (W. H. H.).—When H. spoke of *Cabbages* and *Cauliflowers* as at so much "per dozen," he used the market phrase, which is there understood as "per dozen bunches." The Potato you mention, *Martin's Seedling*, is a good Potato, but smaller and later than we like to recommend.

DUCKS NOT LAYING (A. S.).—They do not usually lay except in the spring.

DOUBLE-GLAZED LIGHTS (A. J. F.).—As you did not have the inner

glass lapped, and consequently the moisture gets in between the glasses, and condenses so as to cause a serious drip, we recommend you to have the joinings of the inner panes closed, by painting them, by means of a very small brush, with liquid putty. We say "a very small brush," because the paint should not extend over the glass so as to obstruct the light.

SLOPING BANK (Co. Cork).—Unless you have this faced with a mixture of coal tar and dry powdered lime, so as to have a face impervious to ascending damp and weeds, you must fail in training fruit trees upon it. If you have such a facing, then upon it must be a wooden trellis, on which to train the trees.

VINE BORDER (A. B. Y.).—When you made this four feet deep, you made it full two feet too deep. If you had referred to what has been repeatedly said in these pages upon the subject, you would not have thus dangerously erred. The turf and sand, with some bricklayers' rubbish, would have been best without any stable manure. We cannot tell you how far to cut back your Vines without knowing how strong they are, and whether you purpose to cultivate on the spur or single-rod system.

DARK ROSE (S. S. S.).—Either *Elegans* or *General Changarnier* will suit your purpose. *Ivy* will grow very well on the north side of your house. It entirely covers a similar frontage in a house we see daily. Plant the *Irish Ivy*. Keep the roots moist in spring and summer, by covering them with mulch, as the soil is so shallow.

CHOICE OF SHANGHAI FOWLS (Brixton).—As we are convinced there is no such variety as the *Cochin-China*, we shall always in future, except inadvertently, speak of them as *Shanghai*. Of Mr. Sturgeon's breed there can be no doubt, of the other we know nothing. Never mind, however, how excellent the original stock may have been, for they may be spoiled by bad intermixtures and bad keep. Never buy the cock and hens from the same yard. This breeding-in will of a certainty give you chickens inferior to their parents.

BEE FLOWERS (Bromley).—Write to *J. H. Payne, Esq., Bury St. Edmunds*. Your other queries next week.

LOVELL SHANGHAI FOWLS (Iota).—No other description of these can be given than that they are smaller-framed birds, and altogether more delicate-looking than the usual large Shanghaes. They are feathered-legged, and ought to be buff-coloured.

KITCHEN GARDEN (A Constant Subscriber).—You will see what Mr. Robson says in his notes to-day, and in some future numbers. If he does not touch upon any subject on which you require information, write to us again.

WEEKLY CALENDAR (Cymro).—The first column states, from various works on Natural History, the occurrences usual at the time in animal or vegetable nature. The two instances you quote refer to the arrival of the Wood-pigeon, and to the Gull leaving the seashore for inland feeding ground.

SHANGHAI FOWLS (Ovum).—February is the earliest month in which to commence placing their eggs under a sitting hen; and it is of little use to continue doing so after the beginning of June. Eggs have travelled more than 300 miles, without injury, but their safety depends on the packing.

FERNS FOGGING OR DAMPING-OFF (M. D.).—To prevent this, give less water and more air; and sprinkle about a quarter-of-an-inch in depth of silver sand, over the top of the soil.

FEEDING COCHIN-CHINAS.—*J. H. P.* says—"I wish to bear my testimony in corroboration both of 'B. P. B.'s' statement, in last week's number of THE COTTAGE GARDENER, and that of 'Q-in-a-Corner.' I can say with the former, that my young fowls have always been exceedingly fat, many of the cocks now weighing nine pounds each; and, as regards their productiveness, it is extraordinary, for one of my March pullets has already laid upwards of fifty eggs. Neither can I discover that they are such enormous eaters as has been represented. My number is two or three above fifty, consisting of five old fowls, and the remainder chickens, chiefly hatched in March and early in April; their consumption now is one bushel of barley and one bushel of middlings, per week, which I purchase for five shillings, making their cost sevenpence over a penny per week each. I should also say, that they are always kept confined to a space of 180 square yards, green food from the garden is thrown to them occasionally, and their porridge is mixed with water in which meat has been cooked."

CELSIA CRETICA.—A clergyman at *Cloyne*, in Ireland, says—"Many thanks for your information relative to the *Celsia Cretica*; it agrees with what my friend says, who is a most enthusiastic botanist, and is at present collecting the different species of fungi about this, and has found some beautiful ones. Shall I ask him to send you sometimes a paper on the botany of this part of Ireland, if you thought it would be useful for THE COTTAGE GARDENER? [Yes, if popularly written.] The *Celsia Cretica* is common in different fields about this, growing in great luxuriance. I always fancied it was a *Verbascum*. I see an inquiry in last number what *Melidiores* are?—*Maladores* must be meant. They are a species of Persian *Ranunculus*, and make a very handsome bed of mixed colours. I send you some seed, in case you may not know them. If you sow them now in a pot, in greenhouse or hotbed, they may be sufficiently advanced to plant out and blossom in spring. I do not think they are much known, even by seedsmen. I enclose you a flower of one remaining in bloom; it is, however, an ugly one, and rather single; some are beautiful. They hybridise so freely among themselves, you can judge the character of the flower by that."

NAMES OF PLANTS (Rev. R. M. Evans).—Your *Sabia* is *S. Grahamii*. (*Quidem*).—Yours is *Ceanothus azureus*. (*A. M. L.*).—Yours is *Leonotis leonurus*, by some called *Phlomis leonurus*.

LONDON: Printed by HARRY WOOLDRIDGE, Winchester High-street, in the Parish of Saint Mary Kalendary; and Published by WILLIAM SOMERVILLE ORR, at the Office, No. 2, Amen Corner, in the Parish of Christ Church, City of London.—November 4th, 1852.

WEEKLY CALENDAR.

M D	W D	NOVEMBER 11—17, 1852.	WEATHER NEAR LONDON IN 1851.				Sun Rises.	Sun Sets.	Moon R. & S.	Moon's Age.	Clock aft. Sun.	Day of Year.
			Barometer.	Thermo.	Wind.	Rain in In.						
11	TH	Bunting mute.	30.120—30.005	49—30	N.	—	14 a. 7	15 a. 4	sets.	☾	15 46	316
12	F	Wood Pigeons flock.	30.347—30.230	46—29	N.	02	16	13	5 a 0	1	15 38	317
13	S	Green Whistling Plover seen.	30.434—30.345	47—36	S.W.	—	17	12	5 38	2	15 29	318
14	SUN	23 SUNDAY AFTER TRINITY.	30.289—30.100	44—25	N.	—	19	10	6 28	3	15 19	319
15	M	Beech leafless.	30.022—29.946	41—19	W.	—	21	9	7 28	4	15 9	320
16	TU	Teal arrive.	29.845—29.815	42—26	N.	—	23	7	8 37	5	14 58	321
17	W	Titmice near houses.	29.821—29.701	35—27	W.	—	24	6	9 49	6	14 46	322

METEOROLOGY OF THE WEEK.—At Chiswick, from observations during the last twenty-five years, the average highest and lowest temperatures of these days are 50.1° and 35.6° respectively. The greatest heat, 63°, occurred on the 12th in 1841; and the lowest cold, 15°, on the 16th in 1841. During the period 88 days were fine, and on 87 rain fell.

BRITISH WILD FLOWERS.

WATER LILIES.—NYMPHEACEÆ.



CHARACTERS OF THE ORDER.—Sepals and petals numerous, overlapping each other like tiles, passing gradually into each other, the former not falling off, the latter inserted upon the disk which surrounds the pistil. Stamens numerous, inserted above the petals into the disk; filaments petal-like; anthers joined their whole length to the filament, bursting inwards by a double longitudinal cleft. Disk large, fleshy, surrounding the pistil either wholly or in part. Ovary many-seeded, many-celled, with the stigmata radiating from a common centre upon a sort of flat pitcher-shaped cup. Fruit a many-celled capsule. Seeds very numerous, attached to spongy partitions of the seed-vessel, and enveloped in a jelly-like covering. Albumen floury. Embryo small on the outside of the base of the albumen, enclosed in a membranous bag; cotyledons leaf-like. Herbs, with shield or heart-shaped fleshy leaves, growing in quiet waters.

NYMPHÆA.—WHITE WATER-LILY.

GENERIC CHARACTER.—Calyx below seed-vessels, of four large, leathery, oblong, permanent leaves, coloured on the upper side. Petals numerous, oblong, placed in several rows upon the base of the germen. Nectary globose, in the centre of the stigma. Stamens very numerous, flat, placed on the germen above the petals; the outermost gradually broadened. Anthers line like, of two parallel cells, closely attached, in their whole length, to the inner surface of the upper part of each filament. Germen stalkless, globose. Style none. Stigma globe-like, stalkless, of numerous rays, pointed and separate at the extremity, permanent. Berry leathery, scarred, of as many cells as there are rays; at length internally jelly-like and pulpy. Seeds numerous in each cell, roundish. Large, smooth, aquatic, perennial herbs.

Stem none. Leaves floating, on long footstalks, heart-shaped or shield-shaped, entire or toothed. Flowers on long simple stalks, large, white, red, or blue, closing, and sinking more or less below the surface of the water, at night.

NYMPHÆA ALBA: Great White Water-lily; Water Rose; Water Can; Can Dock; Watersocks.

Description.—It is a perennial. Root tuberous, often as large as the human arm, putting forth numerous, widely-extending rootlets, with fibrous ends. Leaves floating on the surface of the water, about nine inches wide, oval-heart-shaped, the notch at the base deep, edge of the leaf unnotched, and raised above the water, smooth, veins on the underside not prominent. Leaf-stalks and flower-stalks cylindrical, full of cells within. Flowers large, from four to six inches across. Petals white, from sixteen to twenty-four in number, in two or three rows, wider than the sepals, or leaves of the calyx, egg-shaped, outer ones with a green streak down the back, approaching in their structure more to that of the calyx, as the inner petals do to the structure of the stamens, becoming gradually smaller. Sepals smaller than the outer petals, being about two inches long, and one inch wide, egg-shaped, blunt, spreading, streaked, but shining and smooth, yellowish-green on the outside, with a white edge, within-side white, sometimes tinged with red. Stamens usually about seventy in number, but sometimes more than eighty; filaments short, thick, broad-spear-head shaped, fast to the side of the germ, white, but inner ones yellow and bent inwards; the outer resembling the inner petals. Germ roundish. Pistil without style, stigma divided into about sixteen rays, about ten lines in diameter, which bend back, each ray corresponding to a cell in the germ. Berry globe-shaped, warted with the remains of the filaments, about sixteen-celled, with a very large concave, grooved, scolloped-edged stigma like the Poppy; rind thin and leathery, jelly-like pulp in the cells, which dries up to a spongy substance. Seeds very numerous, flattened globe-shaped, with a blunt angle on one side, yellowish-green, smooth, and shining, buried irregularly in the pulp.

Places where found.—In slowly-flowing rivers, and ponds never without water.

Time of flowering.—July.

History.—The name of *Nymphæa* is aptly applied to this beautiful genus of water-inhabiting flowers, as realizing the idea of the heathen poets, that the waters are tenanted by nymphs or spirits. The flowers arise and open as the sun attains power in the morning, but they close towards the evening, and either recline upon the surface, or sink within the water.

Those virgin Lilies, all the night
Bathing their beauties in the lake,
That they may rise more fresh and bright,
When their beloved Sun's awake.

There is no doubt but that the flower rises out of the water during sunshine that the pollen may perform its fertilizing office; and the same providential wisdom has so arranged that the seed-vessel, as it ripens, becomes heavier than the water, and sinks to the bottom to deposit its seeds in the mud. The tuberous roots are employed to dye a dark brown by the Irish and the inhabitants of the Isle of Jura. Swine eat it. Goats are not fond of it, and oxen as well as horses reject it. *Aphis aquatilis*, and *Leptura aquatica* live upon it. Its use in medicine is now abandoned. (Smith. Martyn. Lindley. Withering.)

WE first saw the noble Pampas Grass (*Gynerium argenteum*) in the garden of the Horticultural Society, last September, coming into flower, and in the first week of October we called at Kew, and found it there in full bloom, planted out on the grass near the plant houses. There were twenty-six or twenty-seven flower spikes on this fine plant, and notwithstanding the general opinion that more species are to be seen at Kew than in any other collection in this country, after seeing most of them, we came to the conclusion that the Pampas Grass was the best plant they had in this national garden, considering that every cottage gardener in the kingdom could grow and flower it as well as they do at Kew.

From that day we made up our mind to put all resources into active play, in order to provide plants of it to try the experiment. With the exception of the electric telegraph, these means were put in force, and the "returns" we shall show presently; but first of all let us say, that the tops of the flower-stems of this grass stood full nine feet high, that the panicles or flowering parts were from eighteen to twenty and twenty-four inches long, the plumes, or feathery parts, falling gracefully on one side, and as the wind moved them about, two distinct shades were produced in undulating waves, a silvery hue passing over a warm cream-coloured ground. It was late in the afternoon, after a shower, and the sun was strong upon them, and never were we more delighted with the sight of a flower. Sir W. Hooker, Dr. Wallich, and two other foreigners were there, and seemed to admire it as much as we did. It was only a few days before this that Sir W. Hooker wrote as follows, "Who does not, among the many friends of Dr. Wallich, rejoice to learn that this distinguished and most liberal botanist has been recently honoured by his Danish Majesty in being made a Knight Commander of the Order of Dannebrog," Who, indeed! And who does not, among the many friends and admirers of these two distinguished and most liberal botanists, "rejoice to learn" that they are both of them looking hale and hearty, and in as high spirits as if their healths had never been impaired, the one in eastern climes, the other by harassing duties inseparable from his calling during the vast changes and improvements which were effected in this garden during the last few years.

There are several plants of the Pampas Grass round Edinburgh and London, but none on sale. It comes into flower in Scotland earlier than in England, but no one has yet succeeded in getting seeds from it in either country. The only place where seedlings of it are likely to be ripened, is the Glasnevin Botanic Garden, in Dublin, and if they are there ripened, the curator, Mr. Moore, ought to make a good harvest of them, as every one on this side of the water is on the look out for the plant.

Of all the plans that we can hear of for increasing it in other ways, that by Mr. Pince, of Exeter, this season, is the most likely to succeed. Instead of allowing his plants to run to flower, he cuts out the flower-stalks as soon as they appear, and thus causes the strength that

would be expended in producing so many flower-stalks, up to nine or ten feet high, to be reserved for the crown or body of the plant for the increase of side-shoots, as one may say; then, by stripping off some of the lower leaves, as they do with suckers of the Yucca or Pine-apple, and by "earthing up" the soil against these side-shoots, he expects them to root before he removes them from the stool, and the idea is very feasible indeed, and no one will be more pleased to hear of a successful issue than THE COTTAGE GARDENER.

We have suggested that Mr. Tweedie should be written to for another supply of the seed of this most desirable grass, but now it appears that no one in this country knows where he is, or whether he is dead or alive, or is off to "the diggings." We see no other course, therefore, but to get some parties to club together and secure the services of Mr. Fortune to go out to Paraguay to establish another new plantation of tea in the far west. No man knows better how to humour the natives of a tea country than Mr. Fortune, and here is a country that has been tabooed for the last forty years as much as ever China was—larger than Great Britain, and as productive in its own peculiar tea or Maté (*Ilex paraguayensis*) as the far-famed tea districts in China, where he gained his well-earned laurels. Let Mr. Fortune be once introduced to his excellency General Urquiza to spin a yarn about tea and cotton plantations,—how the Celestials and Yankee-doodles might be outwitted in colouring tea and teasing cotton along the tributaries of the Parana and Uruguay—and we pledge our best gold pen that the brave old soldier will have more cause to rejoice at his own "decree," by which this, the finest country in the western world, is now opened "to the sails of all nations," than by all that Sir Charles Hotham and the French Chevalier, or the like of them, could say till Christmas.

All this settled, and the plains of Buenos Ayres rumaged for a large supply of our Pampas Grass, see the thousand chances there would be for new plants in Paraguay itself, where no plant collector has ever yet set a foot. Let us have a joint-stock enterprise into this new country, and not rest satisfied till we have *Cavendishia nobilis*, and such Rhododendron-like plants as common in the trade as conifers. Let our India experiments in raising cotton be repeated on the banks of the sluggish Parana and Uruguay, and if we do not like their holly tea, Mr. Fortune knows where and how to get the real thing for them, and for those who know best how to go about the working of both concerns without recourse to "Uncle Tom's" fraternity. B.

TUESDAY, November the 2d, was a great day for Shanghae Fowls and their keepers, for never were a more beautiful lot exposed for sale than on that day, and never before did they realise such prices. We refer to the sale by auction at the Baker-street Bazaar, and by the effective hammer of Mr. Strafford, of the superfluous stock, and the chickens of 1852, of Mr. Sturgeon's celebrated fowls. There were 150 lots, and these realised

£606. Such a result is quite an epoch in poultry-keeping, and refutes beyond all dispute the opinion entertained by *Gallus* and others, that the taste for Shanghae fowls is on the decline.* It is such an event that we shall reprint the catalogue entire, affixing the price given for each lot, with a few comments upon some of them. It is a record and a standard for poultry keepers worth preserving.

Great judgment was shown in the whole of the arrangement. The birds, for the most part, were sold singly; none but good birds, though necessarily varying in excellence, were included in the lots; there was every facility given for examining them, and every information relative to each lot that a breeder might desire to know. There was no puffing attempted, the auctioneer knew that the birds spoke for themselves—they were from one of the best yards in England, and from that only. The result is well told by the exclamation of a foreign gentleman who came in just as the hammer fell on lot 12—“Seven pounds! Can that be for *von hen!*”

That our readers who were not present at the sale may extract from the catalogue as much instruction as we can aid them to, we will observe that nearly every pullet, unless we have otherwise stated, was in colour buff—buff of medium depth—and the feathers were not glossy, but of a soft surface, very much like that of rice paper. Those of our readers who are sufficiently entomological to know the Drinker Moth, a moth very common of an evening late in the summer, will at once be able to realise the colour of some of the best pullets at this sale. We were glad to observe that the necklace, which was strong and dark on many of the pullets, did not depreciate their value. Thus, lot 78 fetched eleven pounds, although it had a necklace, and so far from thinking it objectionable, we think it adds to the bird's beauty. Surely, nothing but the difficulty of getting rid of it ever suggested its removal being desirable.

All the chickens, it will be observed, were the progeny of one or other of three cocks, and as poultry stud books are sure to be kept, we give their names and performances.

“THE PATRIARCH” took the second prize at Birmingham in 1850, when his chickens took the first prize and medal for unusual merit; first prize at Bradford and Huddersfield, in 1851; and the Cheltenham Cup, at Cheltenham, in 1852.

“SAM” took first prize and medal for unusual merit, at Birmingham, in 1851.

“JERRY” took the Gloucestershire Cup (value 5 gs.), at Cheltenham, in 1852.

“The chickens are bred from hens which shared the honours with the above cocks, and others of equal merit. No inferior hen was bred from.”

“The ages are given as near as the keeper can tell; but it is impossible in such a number to be exact as to the age of the chickens, or the hens from which they are bred.”

Lot 1. *Pullet* by Sam, hatched third week in March; 2*l.* 4*s.* 2. *Pullet* by Jerry, hatched third week in March; 2*l.* 10*s.* 3. *Cockerel* by Sam, hatched first week in April; 2*l.* 15*s.* 4. *Pullet* by Jerry, hatched first week in March; 4*l.* 10*s.* 5. *Cockerel* by Sam, hatched first week in March; weighed 10 lbs. on the 13th of October; 3*l.* 12*s.* 6. *Pullet* from Mr. Moody's stock; 1*l.* 5*s.* 7. *Pullet* by Jerry, hatched first week in

March; 3*l.* 5*s.* 8. *Cockerel* by Patriarch, hatched second week in March; 7*l.* 9. *Pullet* by Sam, hatched third week in March; weight 7 lbs.; 3*l.* 10*s.* 10. *Pullet* by Sam, hatched third week in March; 4*l.* 10*s.*

OLD BIRDS.

11. *Hen* from Mr. Moody's stock, and has weighed over 10 lbs.; 4*l.* 12. *Hen*; took first prize and medal at Birmingham, in 1851; 7*l.* 13. *Cock*; took first prize and medal at Birmingham as a chicken, in 1851; 6*l.* 6*s.* 14. *Hen*; weighed on the 13th of October, in full moult, 10 lbs.; 6*l.* 15. *Hen*, bred in 1851; 1*l.* 15*s.* 16. *Hen*, imported in 1852; 2*l.* 7*s.* 6*d.* 17. *Hen*, bred in 1851; 2*l.* 2*s.* 18. *Hen*, bred in 1851; highly commended, as extra stock, at Halifax; 6*l.* 6*s.* 19. *Hen*, bred in 1851; 2*l.* 15*s.* 20. *Hen*, bred in 1851; highly commended, as extra stock, at Halifax; 4*l.* 15*s.* 21. *Hen*, bred in 1851; highly commended, as extra stock, at Halifax; 8 lbs.; 4*l.* 4*s.* 22. *Hen*, bred in 1850; 2*l.* 15*s.*

WHITE COCHIN-CHINAS.

23. *Cock*, purchased, with a hen, of Mrs. Herbert, at Birmingham, in 1851, and selected by Mr. Sturgeon for the best pair of white birds shown, he having the first choice of her prize and medal birds; 2*l.* 13*s.* 6*d.* 24. *Cockerel*, bred from Lot 23, and hen referred to as purchased with him; 4*l.* 15*s.* 25. *Cockerel*, ditto, ditto; 1*l.* 14*s.* 26. *Cockerel*, ditto, ditto; 3*l.* 27. *Cockerel*, ditto, ditto; 3*l.*

CHICKENS OF 1852.

28. *Cockerel* by Sam, hatched first week in April; weighed 9½ lbs. 13th of October; 3*l.* 10*s.* 29. *Cockerel* by Jerry, hatched first week in March; weighed 9 lbs. 13th of October; 6*l.* 15*s.* 30. *Pullet* by Sam, hatched third week in March; 3*l.* 3*s.* 31. *Cockerel* by Patriarch, hatched first week in March; weighed 11½ pounds. 13th October; 10*l.* 10*s.* 32. *Cockerel* by Sam, hatched second week in April; 1*l.* 15*s.* 33. *Pullet* by Patriarch, hatched first week in March; 5*l.* 5*s.* 34. *Pullet* by Sam, hatched third week in March; 7*l.* 7*s.* 35. *Cockerel* by Jerry, hatched third week in April; 2*l.* 5*s.* 36. *Cockerel* by Patriarch, hatched third week in April; 2*l.* 2*s.* 37. *Cockerel* by Sam, hatched second week in April; 4*l.* 10*s.* 38. *Pullet* by Jerry, hatched second week in March; 7 lbs.; 6*l.* 6*s.* 39. *Pullet* by Sam, hatched third week in March; 5*l.* 40. *Cockerel* by Sam, hatched second week in March; weighed 9½ lbs. 13th of October; 2*l.* 15*s.* 41. *Cockerel* by Patriarch, hatched third week in March; 4*l.* 10*s.* 42. *Pullet* by Jerry, hatched second week in March; *Pullet* by Sam, hatched third week in March; 3*l.* 15*s.* 43. *Cockerel* by Patriarch, hatched third week in April; 2*l.* 2*s.* 44. *Cockerel* by Jerry, hatched third week in May; 2*l.* 5*s.* 45. *Pullet* by Jerry, hatched second week in April; 3*l.* 5*s.* 46. *Pullet* by Sam, hatched first week in April; 7*l.* 15*s.* 47. *Pullet* by Patriarch, hatched third week in March; 6*l.* 6*s.* 48. *Cockerel* by Sam, hatched third week in March; 4*l.* 49. *Cockerel* by Patriarch, hatched second week in April; 3*l.* 6*s.* 50. *Cockerel* by Sam, hatched first week in March; 2*l.* 10*s.* 51. *Pullet* by Sam, hatched third week in March; weighed 8 lbs. 13th of October; 6*l.* 6*s.* 52. *Pullet* by Sam, hatched third week in March; 7*l.* 7*s.* 53. *Pullet* by Sam, hatched first week in April; *Pullet* by Patriarch, hatched first week in April; 6*l.* 15*s.* 54. *Cockerel* by Jerry, hatched third week in April; 4*l.* 4*s.* 55. *Cockerel* by Jerry, hatched third week in March; 2*l.* 2*s.* 56. *Cockerel* by Jerry, hatched first week in April; 4*l.* 10*s.* 57. *Cockerel* by Jerry, hatched third week in April; 8 lbs.; 4*l.* 58. *Cockerel* by Sam, hatched second week in March; 9 lbs.; 5*l.* 59. *Pullet* by Jerry, hatched second week in April; 8 lbs.; 4*l.* 60. *Cockerel* by Patriarch, hatched third week in March; 4*l.* 4*s.* 61. *Pullet* by Jerry, hatched third week in March; 5*l.* 12*s.* 6*d.* 62. *Pullet* by Patriarch, hatched first week in April; *Cockerel* by Sam, hatched second week in April; 6*l.* 10*s.* 63. *Pullet* by Sam, hatched third week in March; *Cockerel* by Jerry, hatched third week in April; 5*l.* 64. *Pullet* by Sam, hatched third week in March; 2*l.* 15*s.* 65. *Cockerel* by Patriarch, hatched third week in March; 3*l.* 10*s.* 66. *Pullet* by Patriarch, hatched second week in April; *Cockerel* by Sam, hatched second week in April; 5*l.* 15*s.* 67. *Cockerel* by Patriarch, hatched third week in April; 3*l.* 7*s.* 6*d.* 68. *Cockerel* by Jerry, hatched first week in May; 1*l.* 15*s.* 69. *Pullet* by Patriarch, hatched second week in April; 5*l.* 70. *Cockerel* by Sam, hatched second week in April; 1*l.* 10*s.* 71. *Pullet* by Jerry, hatched first week in April; 8*l.* 72. *Cockerel* by Sam, hatched second week in April; 2*l.* 5*s.* 73. *Pullet* by Sam, hatched second week in April; 3*l.* 5*s.* 74. *Pullet* by Sam, hatched third week in March; *Cockerel* by Patriarch, hatched first week in April; 3*l.* 5*s.* 75. *Pullet* by Patriarch, hatched second week in April; *Pullet*, ditto; 4*l.* 10*s.* 76. *Pullet* by Sam, hatched second week in April; 3*l.* 5*s.* 77. *Pullet* by Jerry, hatched first week in April; 7*l.* 10*s.* 78. *Pullet* by Sam, hatched third week in April; 11*l.* 79. *Pullet* by Sam, hatched second week in April; 4*l.* 6*s.* 80. *Cockerel* by Patriarch, hatched second week in April; 1*l.* 16*s.* 81. *Pullet* by Patriarch, hatched second week in April; 10½ lbs.; 5*l.* 16*s.* 82. *Pullet* by Patriarch, hatched third week in April; 2*l.* 12*s.* 6*d.* 83. *Cockerel* by Patriarch, hatched first week in May; 2*l.* 7*s.* 6*d.* 84. *Cockerel* by Jerry, hatched first week in March, 9½ lbs.; 3*l.* 15*s.* 85. *Pullet* by Sam, hatched third week in April; 7*l.* 10*s.* 86. *Pullet* by Sam, hatched second week in April; 7*l.* 10*s.* 87. *Cockerel* by Sam, hatched third week in March; 5*l.* 10*s.* 88. *Pullet* by Patriarch, hatched third week in April; 5*l.* 15*s.* 89. *Pullet* by Patriarch, hatched third week in April; 2*l.* 12*s.* 6*d.* 90. *Cockerel* by Patriarch, hatched first week in May; *Pullet* by Jerry, hatched third week in April; 5*l.* 5*s.* 91. *Cockerel* by Jerry, hatched third week in May; 1*l.* 6*s.* 92. *Pullet* by Sam, hatched third week in April; 3*l.* 12*s.* 6*d.* 93. *Pullet* by Sam, hatched second week in April; 5*l.* 15*s.* 94. *Pullet* by Patriarch, hatched third week in April; 3*l.* 7*s.* 6*d.* 95. *Cockerel* by Sam, hatched second week in April; 1*l.* 7*s.* 6*d.* 96. *Cockerel* by Patriarch, hatched first week in May; 2*l.* 12*s.* 6*d.* 97. *Pullet* by Jerry, hatched third week in April; 3*l.* 98. *Pullet* by Jerry, hatched third week in April; 3*l.* 5*s.* 98. *Cockerel* by Sam, hatched third week in March; 6*l.* 100. *Cockerel* by Jerry, hatched third week in April; 3*l.* 10*s.* 101. *Cockerel* by Jerry, hatched first week in April; 12*l.* 10*s.* 102. *Pullet* by Jerry, hatched third week in April; 3*l.* 7*s.* 6*d.* 103. *Pullet* by Sam, hatched second week in April; 3*l.* 104. *Pullet* by Jerry, hatched second week in April; 2*l.* 7*s.* 6*d.* 105. *Cockerel* by Jerry, hatched second week in March; *Pullet* by Patriarch, hatched third week in April; 7*l.* 106. *Pullet* by Sam, hatched third week in April; 6*l.* 15*s.* 107. *Cockerel* by Sam, hatched second week in March;

* No one will rejoice more than *Gallus* at this refutation, for he has Shanghae fowls quite as good as any sold on the 2nd. We take this opportunity to add that some parties have, without any just grounds, thought that *Cock-a-doodly-do-o-o* intended to insinuate that *Gallus* was the party who had the eggs out of the pens at the Birmingham Show. Now we happen to know that *Gallus* was not there, and that he is a man of honour, far above such knavery. But let us also add our conviction that *Cocky-doodly-do-o-o* aimed only at the offence, without intending to point out any culprit. We should like to ask, also, of what use for sitting purposes are eggs laid in December, the month of the Birmingham Show?

21. 2s. 108. *Cockerel* by Sam, hatched second week in April; 4l. 109. *Pullet* by Patriarch, hatched second week in April; 5l. 5s. 110. *Pullet* by Sam, hatched third week in April; 4l. 10s. 111. *Cockerel* by Patriarch, hatched second week in April; 1l. 6s. 112. *Cockerel* by Jerry, hatched first week in May; *Pullet* by Patriarch, hatched third week in April; 5l. 15s. 113. *Cockerel* by Patriarch, hatched third week in March; *Pullet* by Sam, hatched second week in April; 4l. 2s. 6d. 114. *Cockerel* by Sam, hatched second week in April; *Pullet* by Jerry, hatched third week in April; 3l. 15s. 115. *Cockerel* by Sam, hatched third week in March; *Pullet* by Patriarch, hatched third week in April; 6l. 116. *Cockerel* by Jerry, hatched first week in May; *Pullet* by Sam, hatched second week in April; 4l. 10s. 117. *Cockerel* by Sam, hatched second week in March; 2l. 15s. 118. *Pullet* by Sam, hatched second week in April; 2l. 15s. 119. *Pullet* by Jerry, hatched first week in April; 2l. 15s. 6d. 120. *Pullet* by Patriarch, hatched third week in April; 3l. 15s. 121. *Cockerel* by Jerry, hatched third week in April; 4l. 122. *Cockerel* by Sam, hatched second week in April; 1l. 10s. 123. *Pullet* by Patriarch, hatched third week in April; 4l. 7s. 6d. 124. *Pullet* by Jerry, hatched third week in April; 5l. 10s. 125. *Cockerel* by Jerry, hatched second week in May; *Pullet* by Patriarch, hatched second week in April; 5l. 7s. 6d. 126. *Cockerel* by Patriarch, hatched third week in April; 3l. 127. *Cockerel* by Jerry, hatched third week in April; 1l. 14s. 128. *Pullet* by Patriarch, hatched second week in April; 3l. 7s. 6d. 129. *Pullet* by Patriarch, hatched first week in April; 3l. 5s. 130. *Pullet* by Patriarch, hatched first week in April; 4l. 4s. 131. *Cockerel* by Sam, hatched third week in April; 1l. 3s. 132. *Cockerel* by Jerry, hatched first week in April; 1l. 7s. 6d. 133. *Pullet* by Jerry, hatched second week in April; 4l. 12s. 6d. 134. *Cockerel* by Jerry, hatched third week in March; 3l. 3s. 135. *Pullet* by Jerry, hatched second week in April; 3l. 12s. 6d. 136. *Pullet* by Sam, hatched first week in March; 3l. 5s. 137. *Cockerel* by Patriarch, hatched first week in April; *Pullet* by Sam, hatched first week in April; 5l. 138. *Cockerel* by Patriarch, hatched third week in April; *Pullet* by Jerry, hatched first week in April; 2l. 15s. 139. *Cockerel* by Jerry, hatched third week in April; *Pullet* by Patriarch, hatched second week in April; 4l. 4s. 140. *Cockerel* by Patriarch, hatched third week in April; *Pullet* by Sam, hatched first week in April; 3l. 15s. 141. *Cockerel* by Jerry, hatched third week in April; *Pullet* by Patriarch, hatched first week in April; 2l. 4s. 142. *Cockerel* by Patriarch, hatched second week in April; *Pullet* by Sam, hatched second week in April; 4l. 7s. 6d. 143. *Pullet* by Patriarch, hatched second week in April; 2l. 17s. 6d. 144. *Pullet* by Patriarch, hatched second week in March; 3l. 15s. 145. *Pullet* by Sam, hatched first week in March; 3l. 15s. 146. *Pullet* by Sam, hatched second week in March; 3l. 13s. 147. *Pullet* by Patriarch, hatched first week in April; 3l. 15s. 148. *Pullet* by Patriarch, hatched second week in March; 3l. 5s. 149. *Pullet* by Patriarch, hatched first week in April; 3l. 10s. 150. *Pullet* by Patriarch, hatched first week in April; 5l. 10s. 151. *White Cockerel*; 1l. 17s.

We intended to have offered comments upon some of the lots, but we have only space to add, that lot 101, the seven months old cockerel that realised £12 10s., was a buff-coloured bird, very square framed, and stout, but that we think the pullets, as a whole, sold better than the cockerels. This probably arose from the fact that they had all reached the age when their greatest beauty is attained; whilst the beauty of the cockerel is not fully developed until he is about two months older.

FORSYTH MSS.

WHEN we stated that SIR JOHN SINCLAIR was the third son of his father, we omitted to observe that he was the only survivor of the three, and we deem this explanation needful, because, without it, our other statement that necessity did not stimulate him to exertion is not sufficiently apparent. The foundation of his classical attainments was laid at the High School of Edinburgh, but he subsequently received the title of LL.D. from three Universities—Edinburgh, Glasgow, and Oxford. In addition to the places in his native country which we have mentioned as returning him to Parliament, we may add Lostwithiel, and Petersfield, in England.

It deserves to be recorded as one of the bright spots in the too usually black treatment of our countrymen by Napoleon Buonaparte, that when he heard of the capture of a son of Sir John Sinclair, who was travelling in 1806 with his tutor, he immediately ordered passports to be given to them, and treated them with the greatest politeness.

One of the successful efforts of Sir J. Sinclair was the

foundation of the *Board of Agriculture*, in 1793, of which he was elected the first President. He was not so successful, however, in its management. It unfortunately acted as if it had taken for its motto "Prices, Politics, and Practice," and was dissolved somewhere about the year 1812, in consequence of the Parliamentary grant of £3000 a year being withdrawn. Its successor, "The Royal Agricultural Society," acts up to its more legitimate motto, "Practice with Science."

Whilst the Board of Agriculture existed, Sir J. Sinclair was very active in sustaining the publication of its transactions, and Mr. Forsyth contributed to them on the subjects suggested by the following letter, dated Whitehall, June 12, 1797:—

SIR JOHN SINCLAIR TO MR. FORSYTH.

You will herewith receive a copy of the plan, according to which it is proposed to have, not only the corrected Reports drawn up, but also the General Report from the Board of Agriculture, respecting the state of the kingdom at large, by which you will perceive that it is intended to have a distinct chapter on gardens and orchards.

It is extremely difficult to find persons fit for drawing up the different chapters, who unite a talent and capacity for writing with a practical knowledge of the different subjects which it is necessary to have explained, and that is particularly the case in regard to gardens, and even orchards, though we have already collected a great deal of information respecting that branch of our inquiry.

I will shortly endeavour to explain the nature of the paper that it would be desirable to have drawn up on those subjects.

Hints for chapter 9, of the General Report, on the subject of gardens and orchards.

Introduction—On the various modes of raising food for man, by cultivating the earth, and the superior quantity of food produced by gardening.

Sect. 1.—On the production of the garden, in an agricultural point of view.

- 2.—On the most productive articles to be cultivated.
- 3.—Of the best mode of cultivating them, the fittest manures, &c.
- 4.—On the best rotation of crops, so as to produce the greatest quantity of human food.
- 5.—On the value of an acre of garden land properly cultivated as food for man, and the number of persons it would maintain.
- 6.—On cultivating food for cattle, &c. (as Lucerne), in gardens, or in a similar system.
- 7.—On the quantity of land which one man can properly cultivate in a year with the spade.
- 8.—On cottage gardens, their proper size, fittest articles of produce.
- 9.—Of the fruit-garden, and the quantity of food that may be produced in fruit-gardens, per acre.
- 10.—On orchards.

Conclusion—On hot-houses.

It is certain, that fruits may be considered rather as a luxury, or, in hot seasons of the year, as a kind of medicine, and as calculated rather for producing drink than food. At the same time, it is a subject too important to be entirely omitted in an agricultural report on the general state of the kingdom and its productions. The paper need not be long, giving merely a general view of the subject, without entering too much into detail.

If you have leisure to undertake such a paper, I am persuaded that, coming from your hands, it would give great satisfaction to the Board and to the public, which I need not add, would be doing a material service to the country.

N.B.—Sir John Sinclair is particularly anxious that Mr. Forsyth should draw up such a paper for the Board, as he has such access to obtain authentic information on the subject of kitchen-gardening in particular, from the numerous body of gardeners in the neighbourhood of London.

COVENT GARDEN.

THOSE only who live, and those who have lived, in London, know the effect a wet day has on the trade of this great mart; but, when such a state of matters continues, not for one day, but for six, the effect is great indeed. Such has been the case for the last week or ten days, and the consequence is, that business of every kind has been at its lowest ebb. It would be strange if, in the midst of all this depression, Covent-Garden should escape; and still there are some who wonder why it should not, for, say they, people must have potatoes, and cabbages, and fruit; these don't spoil with a wet day, and consumers do not go to market themselves. But, when it is considered that a great amount of the market produce is supplied to costermongers, and that during such weather as we have had lately these persons cannot follow their calling in the streets, it will be at once understood how it is the market has been heavy.

FRUIT.—The supply of fruit continues abundant. In APPLES, the winter varieties begin to come up, and among them we observed our old friend the *Catshead*. This is a fine old English baking apple, not so much cultivated in these days as it once was, but still a favourite in all markets. Wherever there is an orchard planted for the supply of large towns, this is one variety which should always be introduced, as it measures well, and is always in demand. The *Yorkshire Greening* has also appeared during the week, and this, too, is one of those which meet with a ready sale; it is well adapted for sauce, and generally commands a good price. The *Hanwell Souring* is another of the same description, and of it there have been several parcels. The prices which these cooking apples make is from 3s. 6d. to 4s., and 5s. per bushel when very fine. *Golden Winter Pearmain*s still continue abundant, and realised from 3s. 6d. to 5s., according to the quality. We have also observed a few *Dumelows Seedling*, but it is rather early for them. *Ribston Pippins* are still plentiful, and make from 5s. to 7s. 6d. per bushel. *Downton Pippins* are to be met with at the same prices, but not so plentifully. We stated last week that *Newtown Pippins* had arrived from America. This, and the *Lady Apple*, is, we believe, the only apples which are imported to this country as rarities, and the reason is, because they cannot be produced in this climate in the same degree of perfection as in America. Even against a wall the fruit of the *Newtown Pippin* never possesses the same fine flavour as is to be met with in the imported specimens. The *Lady Apple* is the variety which is known in the collections of this country and the continent as *Pomme d'Api*. It was first introduced here in the reign of Charles the Second; but the only attraction it seemed to have was, that it "served the ladies, at their toilets, as a pattern to paint by!" We do not know to what use they are applied now, but we may charitably suppose that the lady who bought half-a-dozen the other day in the Covent-Garden arcade had no intention of applying them to such a purpose as the *belles* of Charles's time did. PEARS are also plentiful. *Beurré Capiaumont* continues to take the lead. A few *Bishop's Thumbs*

may still be met with, and several bushels of *Messire Jean* have also been offered. This was, at one time, grown to some considerable extent, but its cultivation has now been discontinued; and we question if there is a nursery where it is now propagated. The orchards from which the supplies have come must, therefore, be of an early date, for since the beginning of this century, at least, it has not been met with in the nurseries in any quantity. It is one of those old French varieties, which were, in all probability, introduced by London and Wise, of the Brompton Park Nursery. We observed also, in the centre arcade, a few *Glout Morceau* and *Passe Colmar*; of these we shall remark on a future occasion. They are both first-rate varieties, and should be in all choice collections.

VEGETABLES.—There is no variation either in the supply or the prices of vegetables. *Cabbages* are plentiful, at from 6d. to 1s. 6d. per dozen bunches. *Cauliflowers* are also plentiful, at 2s. 6d.; and, indeed, every other description of this department continues much the same as last week. We need not, therefore, repeat what we said in our former reports.

PLANTS AND FLOWERS.—The supply of EVERGREENS IN POTS continues to increase. They are generally handsome, well-grown, bushy plants, and consist of *Aucuba japonica*, *Red Cedars*, *Siberian* and *Chinese Arbor vite*, *Tree Box*, *Spruce Firs*, and *Laurustinus*. CUT FLOWERS are becoming more choice, the recent cold, wet weather having played sad havoc among the border flowers. They consist chiefly of *Camellias*, *Scarlet Geraniums*, Double and large-fringed Single *Chinese Primroses*, *Verbenas*, Double *Blue Violets*, and *Azalea Indica*. Some of the BOUQUETS are very beautiful. We promised last week we should, from time to time, furnish descriptions of any which attracted our notice. We noticed one this week which had a fine, large, double white *Camellia* for a centre, round which was a thick belt of double blue *Violets*; these, again, were bounded with another belt of *Scarlet Geraniums*, and the whole fringed round with leaves of the *Rose-scented Geranium*.

H.

GOSSIP.

HE who has written one of the best books upon *British Ferns*, Mr. Moore, Curator of the Chelsea Botanic Garden, is the most fit person to prepare other assistance for those whom he has induced and aided by his little volume to collect specimens of this beautiful order of plants. One of the first wants felt by such collectors is that of a neat and correct set of *labels* for his collection. To supply this want, Mr. Moore has published a complete set of *Fern labels*. The names of the *sections* of the Order are in large capitals; the names of the *genera* in smaller capitals; and the names of the *species* in letters still smaller, but all very legible. The names of the botanists who bestowed each title, and some synonyms are added to the specific names.

The following is an epitome of the results of the cultivation of *Kitchen Vegetables* and *Fruits*, alleged to

be new and superior, that have been published in the "Journal of the London Horticultural Society." The experiments were conducted, and are reported, by Mr. R. Thompson.

Hardy's Shallot Onion.—Strong flavoured; probably good keeper; irregular in size and form; "by a judicious selection of bulbs for seed, a useful sound-keeping variety may very probably be obtained."

Florentiner Pfluckerbse Pea, from Germany, proved to be our *Early Frame*.

Paradise Pea.—Sown May 17th, fit for use July 23rd; four feet high; good quality; abundant bearer; allied to the *Early Charlton*.

Doré de Fitz-James Pea.—Sown May 17th, fit for use July 20th; four feet high; very good, but a curious degeneration, probably, from the Charlton, the pods and peas being yellow.

Sutton's Early Goliath Pea.—Sown May 17th, fit for use July 18th; four feet high; "a very good, early, productive pea."

Sutton's Superb Marrowfat.—Same as Woodford Green Marrow.

Early Prince of Wales Pea.—Sown February 16th, fit for use June 25th. "A well-selected *Early Frame*."

Royal Alfred Pea.—Sown February 16th, fit for use July 14th; three to four feet high; large and good; "a sort of Marrow, but not so sugary as Knight's."

Trial of Early Peas.—The following are the results of sowing of different kinds of Early Peas, made with the view of ascertaining their comparative merits in point of earliness:—

1. <i>Early Frame</i>	.	sown	November 15;	fit	June 4.
2. <i>Early Kent</i>	.	do.	do.	15;	do. 4.
3. <i>Early Emperor</i>	.	do.	do.	15;	do. 4.
4. <i>Sangster's No. 1</i>	.	do.	do.	15;	do. 4.
5. <i>Early Charlton</i>	.	do.	do.	15;	do. 24.
6. <i>Early Long-podded</i>	}	do.	do.	15;	do. 24.
<i>Bishop's Dwarf</i>		do.	do.	15;	do. 24.
7. <i>Early Surprise</i>	.	do.	do.	15;	do. 24.

The first four of the above may be considered identical. Sangster's No. 1 was admitted to have been sent out in mistake. Slight differences will take place in the *Early Frame*, and other sorts, in consequence of the mode of sowing. Hence the *Early Kent* and *Early Emperor*; but they are certainly not decidedly different permanently. They were exactly alike in the above trial.

Haricot de Prague jaspé.—A tall running Kidney Bean; not good in its green state; dried seeds said to be excellent.

Haricot de Belgic.—A running Kidney Bean; pods five inches long, and still tender; tolerable bearer, but not very early; very good, but must have support.

Bush Haricot (Haricot solitaire).—Fifteen inches high, and branchy close to the ground like a bush; pods abundant, five inches long, crisp, transparent, and excellent; commence forming early, and continue long in bearing; dry seeds, speckled red and white; must be grown two feet apart each way. "Forms a valuable succession to the earlier sorts, especially during hot dry weather."

Small White-seeded Haricot.—A variety of the *Haricot viz.*, but earlier, more productive and hardier, "Not so good as various others."

Newington Wonder French Bean.—Excellent; one foot high; early and productive; pods very fleshy, and seeds form slowly; grown in rows eighteen inches apart.

Black Belgian Kidney Bean.—Best both for early and late sowing. Dwarf; sown in pots and planted out when earth warm enough; and late in summer will produce a crop until cut down by frost. "This and the *Newington Wonder* are considered the best varieties of Dwarf Kidney Beans."

Türkische Bohne.—This Kidney Bean is the same as the *Sabre*.

Duchesse de Trévise Strawberry.—Presented to the Society by M. Jamin, Bourg-la-Reine, near Paris, September 6, 1851.—Fruit middle-sized, ovate, deep red; seeds small, rather deeply embedded; flesh pale red, juicy, with a brisk rich flavour. Leaves large, roundish, widely and rather obtusely serrated. Leaf-stalks moderately tall, very hairy, the hairs on these spreading horizontally, but those on the scapes and runners are adpressed. Appears to be a good

bearer, ripening quite as early as Keens' Seedling. It will require to be planted as widely apart as the sort just mentioned. As far as can be judged of it in the present season it seems deserving of cultivation, or, at all events, certainly of further trial.

Salter's Versailles Strawberry.—Presented to the Society by Mr. John Salter, Nurseryman, Hammersmith, Oct. 24, 1852.—Fruit large ovate, sometimes flattened or cockscomb-shaped; dark red; seeds rather deeply embedded; flesh pale, juicy and rich. Leaves middle-sized, roundish-oval, widely serrated. Leaf-stalks, scapes and runners hairy, the hairs spreading almost horizontally. A good bearer, ripening about the same time as Keens' Seedling, to which it will doubtless be preferred by those who like a brisker flavour than is possessed by Keens' Seedling. On the whole, it is worthy of recommendation, being large and a good bearer; many of the new sorts have these properties only, but this has also good flavour.

Beadnell's Seedling Pear.—This was raised by John Beadnell, Esq., West Green Road, Tottenham, and cuttings of it were presented by him to the Society.—The fruit is nearly middle-sized, turbinate, stalk short; eye a little open; skin pale yellowish-green on the shaded side, red next the sun, much speckled with whitish-grey dots. Flesh melting, exceedingly juicy, and rich. It is not buttery, but so melting, when used in its full perfection, that one can scarcely say whether he is not rather drinking than eating. Its period of ripening varies between the middle of September and that of October. It does not keep long after being ripe. The tree is vigorous, and bears very abundantly. Shoots long, bright chesnut coloured where well exposed, much spotted with whitish spots. Leaves moderately large, cordate on the young shoots, somewhat concave and acuminate, serrated; those on the spurs are elliptic. Stipules linear, rather more than half the length of the petioles. This variety cannot fail to be very acceptable on account of its rich, abundant, and highly refreshing juice.

Shanghai Peach.—This variety was sent to the Society Mr. Fortune, who found it growing to a very large size in the North of China.—Along with a plant of it in a pot, he sent some of the peach stones. These were sown and came up abundantly; but they had a very unpromising appearance for fruit, their foliage being narrow, and altogether unlike that of a cultivated sort. They were, however, potted, and when fit, used as stocks for the original. Several trees on these stocks were planted against a south wall, where they grew rapidly. The trees have produced better fruit this year than formerly, probably owing to unusually high temperature in July. The flowers are large; the leaves of the petals deeply coloured. Leaves crenated, with reniform glands. Fruit very large, ten inches or more in circumference, roundish, and very handsome; pale yellow where shaded, and delicate crimson red next the sun. The flesh is pale yellow next the skin, but very deep red at the stone, to which it is attached by strong fibres, yet it is not everywhere adherent like the flesh of the cling-stone peaches. It is juicy and rich, but it requires to be gathered a day or two before it is used. In this state some gentlemen preferred it to old esteemed sorts. It ripens about the same time as the *Bellegarde*. The tree is a good bearer. Buds of this sort have been distributed to the various nursery-men or other Fellows of the Society who applied for them. It must, however, be observed, that it requires a good aspect, and warm situation. It would probably answer for forcing, with plenty of heat. Some buds of it were sent to Paris, and there its fruit is said to be splendid. Like all large fruited varieties it ought to be well thinned."

The following is a list of the *Horticultural and Poultry Shows* of which we are at present aware. We shall be obliged by any of our readers sending us additions to the list, and giving the address of the Secretaries.

HORTICULTURAL SHOWS.

BURY ST. EDMUNDS, NOV. 26 (Chrysanthemums). (Sec. G. P. Clay, Esq.)

CALEDONIAN (Inverleith Row), Edinburgh, Dec. 2.
 HAMPSHIRE, Nov. 18 (Winchester). (Sec. Rev. F. Wickham, Winchester.)
 LONDON FLORICULTURAL (Exeter Hall, Strand), Nov. 23, Dec. 14+.
 NORTH LONDON, Nov. 23, Chrysanthemum.
 SOUTH LONDON (ROYAL), Nov. 11+, Dec. 9+, 16.

POULTRY SHOWS.

BIRMINGHAM AND MIDLAND COUNTIES, 14th, 15th, 16th, and 17th December.
 BRISTOL AGRICULTURAL, December 7th, 8th, and 9th. (Sec. James Marmont.)
 CORNWALL (PENZANCE), January 10th, and 11th. (Secs. Rev. W. W. Wingfield, Gulval Vicarage, and E. H. Rodd, Esq.)
 DORCHESTER, Nov. 18th. (Sec. G. J. Andrews, Esq., Dorchester.)
 HONITON, January 12th. (Sec. H. K. Venn.)
 WINCHESTER, December 1st. (Secs. G. W. Johnson and J. Colson.)

† For seedlings only.

PREPARATIONS FOR EARLY FORCING.

THE shortest day is not far distant, and the adding one more year to the world's history is the signal with many to prepare for garden luxuries during the ensuing spring. Hundreds, however, are not thus patient, but require things much earlier still—and to such the shortest day forms no rule. To obtain Strawberries in March, Grapes and Figs in April, and Peaches in May, requires that the early forcer put his house in order immediately.

First, then, the *Early Vinery*. What must be done—and in what order? If the roots are inside the house, little will be required. If the Vines have been done justice to at the close of their former labours, their roots will have become somewhat dry—a very wholesome condition to remain in during the rest period. In consequence, the border will have become husky on the surface, and, as much of this as has lost its texture, may be removed, and a little fresh compost, if necessary, be substituted; but it will be well to ease the whole over with three inches of half-rotten manure—that from old hotbeds, where half the volume has been tree leaves is excellent. And now, the border being dryish, let us advise a liberal watering with tepid liquid-manure; but, as it is not proper to risk any lodgment of this powerful fertilizer, it may be applied, in a moderate quantity, three days successively, and will thus quietly penetrate the mass. Of course, the Vines for such early forcing have been pruned, and the wood dressed; if not, we pity the forcer, if the Vines have been forced early in former years. The dressing should be applied at twice, but, before doing so, every portion of loose outer bark must be peeled off, for there is no safety if any be left on. Then let the dressing be applied, and a good practice is, to add plenty of lime to the first coat: this, when dry, will prove a tell-tale, and show the operator, at the second dressing, any portion which may have been missed. If the roots of the Vines are partially or wholly *outside*, the first thing should be the covering of the border with litter, in order to at least exclude frost; and if the material be in a fermenting state, all the better. We think that a temperature of 60° to 70° will be amply sufficient until the buds swell, when it may be increased 5°. And here we would recommend the use of a good tarpaulin to cover the litter, in order to keep out rain and snow: perhaps this article will be as good and economical a thing as can be devised. It is quite obvious, that borders which have been exposed to all the autumnal rains contain sufficient moisture to last them until the new year, at least. If any loose material, the remains of former top dressings, remain on

the surface of the border before covering, we would rake it clear off—or, at least, as far as surface fibres would permit, so as to enable the fermenting warmth to penetrate the border. When the warmth of the fermenting material needs increase, it will be well to introduce muck of the droppings from the stable door, in order to impart richness to the border, when rains or waterings are permitted. Thus far the roots; now for the structure itself. Again we may point to the thorough cleansing requisite in all forcing houses before commencement. This, of course, will consist in washing down, or painting, all wood-work, using strong lime-washes to walls or brick-work, and in washing the roof and other lights as clean in the glass as a drinking vessel. All this complete, let us again advise, in all cases, a good stoving with sulphur, continued for several hours—say from daylight to dusk; and if the operator can cover his roof with mats, canvass, or anything, all the better: closing the frames in as much as possible.

It will be here observed, that nothing with foliage on can remain in during this process. The operator will find this a good chance for stoving his Figs, Vines, Peaches, Cherries, &c., in pots or tubs, for they might be removed here previous to the operation. And now let us inquire if the flues have been thoroughly cleaned; if not, it must be done immediately, and hot-water machinery examined and reported on; for a break-down in midwinter will not obtain the gold medals of Regent-street.

All these things duly carried out, the first steps of forcing may be taken, such consisting, in a great degree, in a reversal of the rest policy. A dry atmosphere must gradually be exchanged for a moist one, and the temperature may be allowed a slight advance. In all these things let nature be imitated; generally speaking, what is termed a mild and soft March day may be the model. Thus, suppose a vinery closed in the last week of October, the temperature might run about thus—

First two weeks in November	about	50°
Third week	ditto	55°
Fourth week	ditto	60°
First fortnight in December		65°
Last ditto	ditto	70°

However, these things depend on other circumstances as well; for as soon as the buds are expanding, the night and day thermometer must differ considerably, for thus nature manages her affairs. If the buds are found to break shyly, or irregularly, more time must be given, or the trees will produce an unsightly crop. The syringe may be plied night and morning, using a fine rose, in order not to batter the dressing-off; and sprinkling must be a constant practice, morning and evening, on the floors, walls, &c. If the operator can introduce fermenting materials, it will be of great service to the Vines; such, turned and sprinkled twice a-week, will produce a most genial kind of humidity in the air of the house. Ventilation during the first month will be resorted to, simply to get rid of surplus heat; and thus matters may proceed until the Vines are in leaf. Having other matters pressing for some future papers, we must here just take a passing glance at other candidates for precocity, and, first,

PEACH-FORCING. Here the same preliminaries are requisite as in the vinery; thorough cleanliness, the use of lime, &c. And here may be named the propriety of adding much sulphur to the lime, which, indeed, should be constantly done in all plant structures; the benefits are more considerable than people commonly imagine. The same wash will answer here as with the vines: this having been so often described in these pages, it may suffice to observe, that it is composed of a clay paint, to which much sulphur and lime are added; and soap liquid added at the rate of four ounces of soft soap to a gallon of water. Every crevice in the branches must

be searched with this dressing; and it should be repeated at an interval of a couple of days or so. In addition to all this, the stoving suggested for the vine will so purify the walls, shoots, &c., that it is probable not even the eggs of the insects will escape. It was the neglect of such extreme precautions in former days which caused such a hubbub about red spider, &c. In those times it was counted nothing extraordinary to see houses under good gardeners of the day overrun with this terrible pest; but now, woe to the credit of a man of any standing in his profession who looks coolly on whilst these insect tribes are committing their devastations.

It happens very fortunately that sulphur, which is antagonistic to the red spider, is so likewise to that terrible scourge of the vine, the *Oidium Tuckerii*, or vine mildew: this is, indeed, a fortunate thing. If the Peaches have not been pruned it must be done instantly if for early forcing, of course before dressing, and great care must be taken in this operation. We may here take occasion to dissipate a serious error, a gardening mesmerism, which is totally unworthy of the day we live in; and that is, the impression that every shoot of the Peach *must* be shortened back. This is consummate nonsense; and the error has arisen from the want of a due consideration of the different degrees of ripeness attained by in-doors and out-doors Peaches as we commonly find them. With regard to the latter, it is very generally necessary to shorten them on account of the immaturity of their points; but with the house Peaches the same reason is not, or ought not, to be present; and the chief reason for shortening in-doors, consists in its tendency to keep the lower portions of the tree well furnished.

Peaches and Nectarines, of some age, and which have been tolerably hard-worked, are very apt to be minus wood buds except at the terminal point. We have frequently seen shoots, which were studded with blossom buds from the base to the extremity, preserving but one wood bud at the very point. Now, it is obvious to any one, that to prune this shoot at any point is to destroy it; and this is not all. Trees of this character rejoice in having their leading buds unmolested: they sustain more lively action in the tree than mere secondary shoots; trees of this habit being below the medium point of luxuriance, and requiring in general some stimulus to keep them going. Let, therefore, common sense prevail in this matter; do not shorten any shoot of a doubtful character; rather leave it to nature. The best wood of all is that which is studded with triple buds, from the base to within a few inches of the apex. These triple buds are almost invariably a wood bud in the centre, and a blossom bud on each side; and are indicative of that happy medium of strength which at once points to well-balanced habit and to a high degree of fruitfulness.

Vines and Peaches, in pots or tubs, must undergo a similar ordeal to those planted out, before forcing; and greater caution still must be exercised over the pruning of pot Peaches. If fermenting materials are at work in the houses, we would make up one portion milder in character, by introducing a good body of tree leaves amongst the warm material, and securing a steady bottom-heat of about 60° to 65°; in such the Vines, Peaches, Figs, &c., in pots or tubs, might be plunged for awhile.

STRAWBERRIES.—Although some persons must needs introduce these in November, or even earlier, in order to have them ripe by the end of February, or beginning of March, yet not one of these ever dreams of success, that is to say, of Strawberries not only red, but actually fit to eat. However, we will not step out of our way to check the progress of science and the refinements of luxury, inasmuch as such recreations have, at least, a wholesome tendency. For, although the gar-

dener may be occasionally troubled with the nightmare whilst his Strawberry blossoms are setting, or, rather, making an effort to do so, his conscience may all the time have a mere sinecure office of it. Nevertheless, it is a pretty-well recognized fact, that few gardeners attach any mighty importance to Strawberries introduced whilst the days are shortening. To those who choose to do so, we beg to suggest the use of a frame or pit for awhile; not that there is any magic about such structures, but that in them the two great desiderata as to Strawberry commencement are most generally to be met with, viz., proximity to the glass, and a little warmth without the smell of fire, and, in addition, those genial gaseous emanations which mere fire and water can never supply equally to sweet fermenting materials. In such a structure, plunged in a body of fermenting materials, which is merely suspected of containing a little warmth—say 60°—the Strawberry plants may take first lessons in the art of forcing. Here, with an atmospheric temperature of 50° to 55°, they may remain three weeks, or, indeed, until the blossom-bud first becomes manifest, when they will do with more warmth, always keeping them near the light and ventilating points. Like Dutch bulbs, however, about which our good friend Fish could tell a pretty tale, it is of no use talking of schemes and appliances if the bud has not been well organized in the preceding summer. As our sage ancestors used to say to hot-headed young folks who were o'er hasty to get married, "as you make your bed so you must lie," so may be said of the Strawberries; if the bed is not well-formed, it matters not whether pit or house.

In putting by our "Gillott" for a few days, we may just observe, that all forcing stores, such as Vines, Peaches, Apricots, Figs, Cherries, Strawberries, &c., whether in pots or tubs, must have protection immediately at their roots, if not hitherto afforded them. Plunged above the ground level, on dry ground, and their branches covered in very severe weather with a little clean straw, they will be in a position to introduce to a forcing process at any time. Trees in pots, thus situated, cannot afford to lose what few roots they possess; and, it must be remembered, that in pots above the ground level they are in a most defenceless state: they love not the every-day fluctuations of a changeable November and December.

R. ERRINGTON.

SCARLET GERANIUMS.

SOME time since, I made a promise to our correspondent, "Devonian," that I would find out for him all that was necessary to know about the new Scarlet Geranium, *The Amazon*, of which he himself spoke highly. He wanted a good selection of them for planting against a high wall, where they live out the winter with him in Devonshire, with a slight protection. When I was at Clapton, the other day, about the packing for long voyages, the first plant I inquired about was *The Amazon*, and I find it is a horse-shoe variety, and the very best of all scarlets, for a wall, or for the centre of a very large bed of them, or for making specimen plants ten or twelve feet high, as Mr. Macintosh has them at the Duke of Buccleuch's gardens at Dalkeith, near Edinburgh. If "Devonian's" border is good, *The Amazon* will reach the top of his wall in four years, or five at the farthest. All this I can vouch for, from my own experience, for I have grown *The Amazon* for eight years, and I have described it in THE COTTAGE GARDENER long since. Mr. Cole, now gardener at Oldford, near Birmingham, was the first man in England who saw this Geranium. In 1843, he pointed it out to me among a lot of seedlings, from the *Shrubland Scarlet* alias *Smith's Emperor*. From that day to this it has

been my own peculiar favourite of all the Scarlet Geraniums, so much so, that no one ever had a cutting of it. All this I told Mr. Low, and pointed out the variety to him, out of many hundreds of plants he had in a long range of pots, before he told me which was *The Amazon*. It has the largest flower-truss of all the race, and if I had anything to do with the Gardens at the New Crystal Palace, I would buy up every plant Mr. Low could spare of it, in addition to the 50,000 scarlets already bespoke for that establishment. I would plant it in masses, in the centres of the largest beds, placing broad bands of *Punch* next to it, and a double row of *Tom Thumb* next the outside. For a match, and as a contrast to this, I would plant equal numbers of the oldest and strongest *Salmon Geranium* I could find, then the *Pink Nosegay* to balance *Punch*, finishing with *Lady Middleton* on the outside. I would either so arrange them, or I would put the scarlets in pairs or match beds, and the shaded pinks the same. This last would be the most complete arrangement, but either way would be more grand and imposing than any other that all the gardeners in England could make out of all the scarlet breed put together. If *Cherry Cheek* could be depended on, it would be better than the *Nosegay* to make the shading more perfect. It would be dangerous, however, to trust to it, where all the beds will be made with fresh soil, and where we all expect to find flower-gardening, like the rest of the designs, in the highest style of art. Meantime, Mr. Low's plants of *The Amazon* are from a foot to thirty inches high, and the price is about 3s. 6d. a plant. Next April we shall have it for 1s. or 1s. 6d., but then it will hardly be so cheap as it is now, because the plants will not be nearly so large and strong.

Here I met with a good stock of the *Shrubland Pet*, the very opposite to *The Amazon*, being the smallest flower of its class, and, like *The Amazon*, it has been raised by more than one grower. I traced it to two different hands this summer; and Mr. Ayres told me of three others who lay claim to its origin, and very likely they are all right; but what is better for our present purpose, I found, down near Oxford, an entire new bedding Geranium, that is, new to me and THE COTTAGE GARDENER. I only made mention of it once, and that as a desirable one to cross from, if it was a breeder, which I now find it is not. We must have a bed of it to match *Lady Mary Fox*, if the London trade can supply so many of it. It is the only one in existence that will match *Lady Mary Fox* exactly, and it is just as good as her ladyship, which we all know is the best of that race. The name is *Touchstone*, and, like *Lady Mary Fox*, it should never be propagated, except early in the spring, and old plants of it should be cut down quite close to the hard wood every autumn, when the plants are taken up for the winter. Forcing either of them in the spring is much against them, but when the old plants are cut and potted in the autumn, a slight bottom-heat in an airy pit for five or six weeks would do them real good; and the next best place for them would be high on a shelf near the glass, in a dry stove, as all stoves ought to be from the middle of October to the end of November, the time when this assistance would be so beneficial to *Touchstone*, *Lady Mary Fox*, and the *Golden Chain*, and also to all other Geraniums under similar circumstances, if we could but afford space for them.

For my knowledge of *Touchstone*, as a first-rate bedder, I am indebted to the Rev. J. Lys Chilworth, Wheatley, near Oxford, whose garden was as clean as a drawing-room, and as tastefully planted as any I have seen since I left Suffolk. His beds are also as full of bloom as we ever had them at this time (Oct. 10th) at Shrubland Park. *Touchstone* here being as good as ever I saw *Lady Mary Fox* in August; and I was told

that "you could not see a leaf in it" earlier in the season, for the mass of crimson flowers.

Ethiopia prostrata was here all bloom: the only place where I have seen it this season. The secret of its doing so well is, that old plants only were used, and divided late in the spring, allowing them room enough to spread well before they were too crowded. *Linum flavum* makes a hardy bedder here, and is never taken up; it was then in bloom. *Unique* was very fine, and so was *Calceolaria Kayii*, and another dwarf yellow *Calceolaria* called *Compactum*, which is very common about Oxford. The old *White China Rose*, which I have so often mentioned, will be in bloom here to Christmas if we do not have much frost. There are several beds of this Rose at Kew this season, where it is tallied *Rosa alba*, proving what I have always said of it—that it was fortunate enough to get about before they began to name the sorts from the breed of the old *odorata*. There was a large plant of *Helenberg* Rose against the house in fine bloom: this is a climber of the Noisette family, and, as it would seem from this example, among the best of them; the flowers are—or were this time—of a deep crimson colour, with the foliage and growth looking very healthy. A fine plant of *Chionanthus fragrans*, or *Grandiflora*, ripened seeds the same as at Claremont (p. 60). The seeds vegetate freely, and it is a thousand pities that a seed of this kind should be lost anywhere until the plants can be sold for five or six shillings the dozen. I saw many plants here that are very scarce round London. Among them are some of the best *Cistus*, or Rock Rose, *Bomarea*, a section of the *Alstromerias*, *Pentstemons* and herbaceous plants. In the greenhouse, *Gesnera zebrina* was in full bloom, just a month earlier than most gardeners in large places, who aim at large specimens, can bring it into the rooms or conservatory. I saw it also in bloom in a conservatory at the end of last August, in the next parish to me, and the mode of culture I found to be exactly the same in both places; and, as October is the worst month in the year for keeping a greenhouse, or any house gay with flowers, I would recommend the same plan to be adopted with part of the stock wherever this *Gesnera zebrina* is grown, or, indeed, wherever a cucumber bed is made in March. Early in March they pot, in the same pot in which they flower, large tubers whole; three tubers in a No. 32-pot. From 75° to 90° is the general heat for the bed at that time, and the pots are kept in such heat to the middle or end of May, when they are removed to adorn the greenhouse, and help to fill it along with other nice things after the "greenhouse plants" are turned out for the season. The *Gesnera zebrina* is so soft and fleshy in all its parts, that this violent change does not show any bad effects, but the shock puts a dead stop to the rapid growth of the plant for a while—a sudden check, as we gardeners say. A disposition to flower is then induced, and when the plant moves on again, a flower spike appears, which takes a long time to come to perfection under a greenhouse treatment, but still they do come to perfection a month or two sooner than by stove and shift culture, although the plants be only a quarter of the usual size. I think the following application of this principle would succeed; and if it would, I know many a good gardener who would reap the benefit of it. Take single, whole tubers, and pot them in No. 60, or three-inch pots, placing the bottom of the tuber on the drainage crock, and filling up, quite firm, with half peat and half leaf-mould compost; any time in February or early in March, plunge them into a brisk bottom-heat of 80° to 85°, and a damp, growing atmosphere. After the first watering, no more will be needed till you see the leaves appear; then keep them constantly moist at the roots and over head, and get as much growth out of them as your means can furnish before the end of May; then turn them into a cold pit, with a very dry

atmosphere, and keep the sun from them till they harden a little. It is now Midsummer, and time for them to be in an airy and light part of a greenhouse, or late vinery; and to guard against the scorching of the roots in these little pots, have all double potted, that is, to put the No. 60-pots inside 48-pots. Before the middle of July the flower-spikes ought to appear; at any rate, keep them on short commons till they do "show;" then sort them into fives, keeping each five, as near as possible, of the same forwardness; water them all thoroughly, and put each five into a No. 16-pot, one in the middle, the rest equally apart near the sides. No matter how rich the compost is for this move so that it is light and lumpy, to let off the large doses of very weak liquid-manure, with which the future waterings are to be made, until the first flowers open; and during this interval, let them be in a close, strong-growing heat, so as to expand all their parts, as much as possible, before they are fit for showing off. After all, this is only a new application of a very old rule by which little Coxcombs not much bigger than your thumb at the time of "showing" the flower, or crest-bud, have been made to expand enormously—and why not *Gesnera zebrina*? Even with a moderate growth, five of them in a pot will make a handsome specimen; the flowers will be just as numerous, and the flower-spike nearly as long as if the plants were grown to their last in single pots, besides being six weeks earlier. The other half of the stock of roots will be used to make the splendid specimens now so much admired.

D. BEATON.

TENDER PLANTS THAT MAY BE KEPT DORMANT IN WINTER.

A PHILOSOPHIC moralist would be apt to say, that modern *upwardism* was one of the plague spots of society. True, we may realise the blessing of contentment, and not be backward in using legitimate means for improving our condition. Ambition only becomes an evil, when, in aspirations after the future and the unattainable, we forget our present advantages and their attendant responsibilities. How many destroy their happiness, keep themselves in a perpetual worry, and render themselves incapable of all useful, generous effort, merely because they *will* aspire to dangle within the extreme bounds of a higher grade, when they might otherwise have been happy, prosperous, and useful, as standing in the foremost ranks of the hardy sons of honourable labour. "Then why is it that you, in your COTTAGE GARDENER, talk so frequently of plants which none but the rich can possess and attain; conjuring up envy in some, discontent in others, an aping refinement in more, and a straining to have plants like their *bettors* in all?" Just because, I believe that *envy* belongs to *no* particular condition in life, and can only be associated with the *diminutive* in mind; because, I believe that a man may have something of philosophy in his head, and a great deal of the real gentleman in his manners, and be all the happier, and more faithful to his duties in consequence; because, I know that the sight of, and the acquaintance with, without the possession of, the beauties of vegetable nature, ever exert a cheering, humanising, bettering-of-heart tendency; and because I am more than convinced, that the love of gardening, however promoted, and however directed, is a most powerful auxiliary for securing happy homes, and promoting self-respect, and manly independence of feeling. "Aye, that is it, they get so *uppish*, and so independent; since they have had these fine cottages, large gardens, and allotments, they think nothing of *charity now*." So spake, not long ago, a querulous old gentleman. I hope it is true. Charity, rightly administered, is one of those virtues that breathes peculiarly of

the atmosphere of heaven. But I trust that the day is dawning, when an addition to the reward of labour shall be no longer given in the name of charity, as an opiate to the conscience, which *ought* to have been given at once as a matter of simple *justice*. Self-respect can stoop to charity *only* as the last alternative. Gardening fosters that self-respect, because, in the country especially, it is a safeguard against vice and idleness. Mind *will* think, and the good must be presented as the opponent of the bad. Glad are we to know, that there are those high in rank who glance over these pages. Pleased are we to see THE COTTAGE GARDENER on the tables of gardeners, of Dukes and Earls; but more delighted, more satisfied would our ambition be, to know that this little manual circulated *more* among the tradesmen, artisans, and labourers of our land. Some, in their enthusiasm, might spend more on plants than their circumstances would justify, and thus develop *upwardism*. In all cases not very extreme, I am so convinced of the good that would follow, that I should be inclined to shut one eye at least. To suit a few with aspirations above their general conveniences, I will pen a few notes on the subject that heads this chapter, even though they be chiefly remembrances.

I. *Scarlet Geraniums*.—These have been discussed under almost every conceivable circumstance. Still, I must not pass them by, as they generally constitute the first step from the democratic to the aristocratic in gardening. 1st. There are those that have been growing and blooming in pots and boxes. If you have not given them much water lately, they will be rather firm in their stems; and kept so dry as that they do not shrivel, they will be preserved easily in any hay-loft or shed, where just a little light can be given in fine weather. All fading leaves should be removed, and the points of the shoots, if at all succulent. In March and April, you must bring them more to the light, and moisten their stems in a sunny day. By-and-by, when the weather becomes warmer, you must water them at the roots; and, if set out-of-doors, you must protect from wet and frost; and when the plants have broke nicely, you may pick off some of the old soil, and top-dress with what is fresh and rich. You will thus have abundance of bloom. 2nd. But you wish to preserve those growing in beds and baskets; and as the roots have been cut in autumn, you would like to keep the plants green all the winter, after taking up and potting them. Then, though the plants may be somewhat dormant, you will be obliged to give them a fair portion of light, as well as keep them from frost. Any building, or an odd room where these conditions are obtainable, will do. 3rd. "Here are a lot more that are still in the ground, and have received no preparatory process, and I have nothing but a close shed, with a window and largish door to preserve them, or a small bed covered with lights, and I should like them to do well next year. Will either place do?" Take up the plants carefully from the beds, and, as your room is scarce, cut away all the softest part of the plant, and the whole, or, at least, all the larger leaves. Then have a pot of quick-lime, if there is some powdered charcoal in it, all the better; dip the top of the plant in it so as to smear all the cut parts; and then pack the roots as closely as you can in dryish earth, leaving the tops exposed. You may place them in moveable boxes if you like. I make many out of any old boards, but if, in your pit or shed, there is no danger of damp from below, they will do as well, and occasion less trouble by being packed on the floor. Light and air must be given them at all suitable opportunities. If they see neither for a week or more, in severe weather, they will take no harm. Frost must be excluded, and any decaying part must be removed. By the end of March they will have become such a thicket, that you must move them to give them room, to en-

courage the growing and then the hardening process. 4th. "I have no plants, but Neighbour *Lose-nothing* has offered me plenty of cuttings. I have a nice, open, light lumber-room, from which frost can easily be excluded." Well, "better late than never," though it is never good to be late. Get some shallow boxes, say three to four inches deep, six to twelve inches wide, and from two to three feet in length; put a little rough stuff in their bottom, and then fill rather firmly with dryish sandy earth. Make the cuttings rather large, leave only a leaf or two at their points, let the base dry for a day or two, and then insert them firmly and thickly in the dryish soil. Now, here is the *particular* part; in a sunny day you may dew the foliage with water, but *not a drop* must go into the soil *until* roots are freely forming. In all these cases the succulent juice stored up in the plant and cutting is that upon which you must depend. Every position indicated is, therefore, better than your own sitting-room would be, whatever bustling care you might give them, just because your fires would dry the atmosphere, and rob the plants, &c., of their self-contained moisture.

II. *Fuchsias*.—These, if not the first, are second favourites with all our artisans of taste. Nothing beats them for windows, baskets, and small gardens. As successions are easily obtained, the plants should *never* remain in-doors whenever some of the leaves begin to fade. Ripening of their wood in the open air, and a good rest, are essential to their future success. A shed or room, where they can be protected from frost, will suit them better than a window or greenhouse. If the pots are plunged, or covered over with a damp material, such as moss, the plants will want no water until fresh growth commences in spring. The damper the plants, the more liable to injury from cold. A lady, very fond of these and other plants, kept them nicely in a light lumber-room in the garden. Her good husband, though equally fond of flowers, knew nothing of their management, and wisely never interfered. One day, however, he took pity on the woe-begone aspect of the plants: he would give them a *refresher*; and tops and bottoms got the water until the place was sailing. He intended to surprise his lady on the following day, and he did. To give them every chance, he left the window open, and forgot to shut it. That night a severe frost left wreck and desolation. His mistaken kindness did the mischief. A little dry hay is useful for throwing over the tops in severe weather.

III. *Begonia Evansiana*.—This is a great favourite with our window gardeners, and deservedly so. I have already written its praises in these pages. I had pots this summer, with four and five stems in each, that were so truly fine, that some of our acute nurserymen did not know what it was. Whenever the flowers drop, and the leaves begin to fade, the plants should be set out-of-doors, where they can have plenty of sun and little water. By this time, the stems will have fallen off, or may be broken off close to the surface of the pot—and the pots themselves be stowed away in any dry cellar, room, or shed, and will take no harm in the dark, until the young shoots have risen a couple of inches in the spring. Then they should have light, and shortly have the roots divided, so as to have one, or several, shoots to a pot. If a little more heat than can be commanded in a greenhouse window can be given, such as the corner of a moderate hotbed, for a month, the plants will thank you for it in future.

IV. *Canna*.—Many of the *Canna Indica* shoots may be preserved in a manner similar to the last, provided dryness is attended to. When raising from seed a hotbed must be secured. Most of them have rhizome roots, or underground stems, resembling the common ginger. Most of them would be too large for windows, but they would look very striking in the centre of baskets and vases. I

have saved the roots of *Indica* in this manner; and also *G. gigantea*, a denizen of the south of Europe. I have heard of others, such as *aurantiaca*, *coccinea*, *lanceolata*, and *patens*, &c., being so created. But to do them well, and get them forward, all would require a help from a hotbed for six weeks or more in the spring.

V. *Tall growing herbaceous Lobelias*.—Our good friend, Mr. Appleby, has alluded to these lately, and you cannot do better than follow his directions. *Cardinalis, fulgens ignea* and *splendens*, are fine scarlets; *Pyramidalis* and *Syphilitica* are fair blues, all of which may be easily kept. All of them, treated generously with rich compost, and plenty of water, do well, either in pots or beds, if they get the help of a little extra heat in spring. At this season, I used to cut over the stems and take up the roots, in balls, and pack them in earth in a potting shed, or such place, where frost could be kept from them. I have also built them one above another like bricks against a wall, never disturbing them until the heat of spring caused the suckers or young plants to move, when they were taken out, divided, and potted. Two or three old plants *now*, will give you a hundred then.

VI. *Salvia fulgens, patens, coccinea, Chamædrifolia*, &c., may be taken up and kept safely in soil, in sheds, during winter. Many will stand in the open ground, with a slight protection of moss, or coal ashes, similar to the hardiest fuchsias. But, with the extra labour involved, the plants will not bloom so early, nor so freely, as those that have been moved and kept dormant in winter. Even the last will not beat young plants kept slowly growing in winter; but then the trouble will be greater, and you must find means for giving light, as well as keeping out severe frost.

VII. *Commelina tuberosa, Mirabilis* (Marvel of Peru), and *Dahlias*, may all be treated similarly. The first is worthy of more general cultivation, on account of its blue colours. The second has nothing of the wonderful and *marvellous* about it *now*, but still a few plants in a small garden are always interesting; and the third everybody thinks he can keep, though I have known many amateurs who have lost their collection year after year. In all, three things, if not essential, are great helps to success. 1st. Growth must be checked artificially, or by frost, before the plants are cut down. 2nd. The roots should remain in the ground some days afterwards; the centre top part, however, protected from wet and frost. 3rd. When the roots are taken up they should be slightly dried, and then packed in dry earth, leaving just the tops exposed, and over which you can throw protecting material in frosty weather. The roots or tubers will thus be kept sound and fresh, and you will escape rotting on one hand, and mummy-drying on the other. When growing in spring, the shoots may be thinned, and the plants potted or planted out at once, to receive a little protection; but in all cases, growth and flowering would be expedited if the plants received a little assistance under glass, in a slight hotbed.

I stop here for the present. It will be seen, that a small room, or shed, with several bins or platforms, one above the another, may thus be made the repository for many useful plants. The more light such places have the better, as it is easy to block up with coverings in severe weather.

R. FISH.

JOTTINGS BY THE WAY.

(Continued from page 63.)

AFTER leaving Coventry I visited Northampton, a town almost as ancient as the former. The neighbourhood is thickly strewed with the seats of the nobility and gentry. The day I arrived I was fortunate enough again to witness an Horticultural and Floricultural exhibition. It was held in the new Town-hall, a splendid, well-

lighted room, and well adapted for the purpose. The plants were well grown and beautifully flowered, especially *Dipladenia crassinoda*, *Aphelandra cristata*, *Allamanda cathartica*, *Russelia juncea* and *grandiflora*, *Crinum amabile*, *Justicia carnea*, *Pteroma elegans*, and varieties of *Lilium lancifolium*, which were exceedingly well grown and bloomed. These plants would not have disgraced Chiswick or the Botanic Regent's-park shows. There was also a fine collection of excellent vegetables, especially Potatoes. One, named *King of Beauties*, was as beautiful as a peach—white skin, size medium, eyes shallow. This was a seedling, exhibited by Mr. Watts, a market gardener. Mr. Watts said that it had never been diseased. He was kind enough to give me one, which I shall propagate as fast as I can, and, if it prove one that will withstand the attack of that fatal disease, the potato-rot, it will be a treasure indeed. There was also a variety known in that locality by the cognomen, *Holland Red*. This also, I was assured by several gardeners, was a hardy variety, not one in twenty being diseased; among ten varieties grown in one garden this was the least diseased of all; it is round, medium size, and reddish skinned. This was exhibited by Mr. Mackie, gardener to E. Bouverie, Esq. I obtained two sets of this variety. *Jackson's Improved Ash-leaved Kidney* is also a fine variety, and was free from disease. These facts are useful; and if every potato-grower throughout the country would notice the varieties that are the least subject to the disease, and publish his notes, a number of valuable varieties would become better known, and might be distributed more throughout the kingdom. Here, as at Coventry, the cottagers' vegetables and hardy fruits were quite equal in quality to the gentlemen's gardeners. And when we recollect that such products must have had great pains, and regular, almost daily, attention bestowed upon them, it is a proof that the encouragement given to cottagers, by giving prizes for their productions, is a great inducement to them to strive to deserve such distinction. By such notice and encouragement, habits of industry are, as it were, incidentally adduced amongst a class of persons who would, probably, without such a stimulus, have spent their hours in idleness, if not in pursuits more demoralizing and injurious to their comfort and that of their families here and hereafter. It is a matter of regret to me, and, no doubt, to many others, that there are so few cottager's prizes given near the metropolis. The London Horticultural Society has begun to give prizes, at their rooms, in Regent Street, for vegetables, and there is no reason why they should not open a class for cottagers especially. I am quite sure the subscribers would not grudge a few pounds a-year for such a praiseworthy purpose. And in large hamlets round London, such as Hammersmith, Highgate, Hampstead, Clapton, Clapham, and others, there are plenty of benevolent clergy and gentry that would be glad to subscribe to have exhibitions purposely to encourage their poor cottage neighbours. If I live, I shall certainly try to establish one at Uxbridge. There is no neighbourhood where cottage gardens are better kept, and they would be still more so if due encouragement were given to the owners. At this (Northampton) show, I had the pleasure to meet my esteemed friend and able coadjutor, Mr. Fish, which was an agreeable surprise indeed. He was there in the capacity of Judge, and our readers will agree with me, a better could not have been chosen. I understand he fills that office here frequently, and I am sure we should be glad if he would give a few jottings by the way when he attends such pleasing meetings. The reports of country exhibitions shows the progress of gardening in various parts, and is always interesting to the garden-loving-reader.

The next day I visited Pinedon Park, the residence of M. Dolben, Esq. The lawn in front of the house is

large, eight or ten acres, I should think. It was planted thinly with all the choice Coniferæ. I was particularly pleased with a healthy specimen of *Pinus patula*, fifteen feet high, and twelve feet through, foliage light green, and elegantly drooping. This species is said to be rather tender, but here it was perfectly hardy, and did not appear to have suffered from frost in the least, every branch being perfect. *Pinus insignis* was thirty feet high, and twenty feet diameter; a perfect pyramid of branches, clothed with healthy foliage of the richest green imaginable. *Cupressus torulosa*, twenty feet high; *C. lusitania*, a rare species in this country, twelve feet; *C. thurifera*, fifteen feet high; *C. macrocarpa*, fifteen feet; and *C. expansa*, twelve feet. *Pinus nobilis*, a handsome, healthy plant, with a strong leader, and short stem, six feet. The great rarity, however, of this place is the *Abies Douglassii-pendula*, a tree unique, and only in this garden; no other place, I believe, possesses a plant of it. In one part of the grounds is a fine dense avenue of old Limes, nearly half a mile long. In walking through this, the spectator might easily imagine he was in some religious edifice, the cloisters of an old abbey, so imposing and solemn is the effect it has upon the senses. Mr. Dolben is justly proud of his choice collection, and spares no pains or expense to add to it every new species of Coniferæ.

Close to the town is an ancient place named De la Pre, the residence of E. Bouverie, Esq. The gardener, Mr. Mackie, two years ago, had occasion to rebuild or improve an old vinery. The vines were about five years old. He took them carefully up, preserving every living root, made a new border, considerably elevated it, replanted the vines, and they were, when I saw them, in most excellent health, with a fine crop of grapes, without a single shanked berry; and, what was more remarkable, they were all of that somewhat tender vine, the Frontignan variety. This was an experiment, and shows what care and judicious management will effect. In the pleasure grounds were some noble Cedars of Lebanon, a gigantic Tulip tree, sixty feet high, which flowers every year; a long yellow-flowered Horse Chestnut; and a fine succession of that rare tree, the *Pinus Ulmaveana*, eighteen feet high.

On the back wall of a forcing house, Mr. Mackie planted, five or six years ago, a number of Roses, chiefly the Provence varieties. These, he said, furnish him with an abundant crop of Roses from February to June. I was much pleased with this wall of roses, and think it worthy of adoption in every garden where cut roses are in request.

T. APPLEBY.

(To be concluded in our next).

THE PETUNIA.

(Continued from page 86.)

In my last paper on these showy plants I described the properties of a good variety; I now proceed to give its culture, and trust my remarks and instructions will be useful to such readers of THE COTTAGE GARDENER as may either cultivate Petunias, or desire to do so. The subject may be divided into, 1st, Propagation by cuttings and by seed; 2nd, Soil; 3rd, Summer treatment; 4th, Winter treatment; 5th, General management, so as to render the plants fit for exhibition.

1st, *Propagation by Cuttings*. Petunias are easily propagated by cuttings during nine months in the year; that is, from February to October. The best cuttings are the young tops of rather weakly growing plants. I have always found that cuttings of most kinds of soft wooded plants, such as *Calceolarias*, *Heliotropes*, *Ageratums*, and such-like, when growing very strong with thick succulent stems, soon damp off, especially in early spring, or late in the autumn, and more especially if put

into heat with a view to strike them quickly; whereas, if the cuttings are rather weak, their leaves do not transpire so much, and the cuttings, consequently, live longer without roots, and have time to send them forth before they perish for want of support from the roots. In spring, the cuttings require a gentle hotbed; but in summer and autumn they strike root readily enough in a cold pit or frame. The cutting pots should be prepared in the usual way; that is, drain the pots well by filling them half-full with broken potsherds; upon these place a layer of the rough siftings of the compost, and upon that place a layer of rich, light, very sandy compost, nearly up to the rim of the pot; and lastly, fill up the pot to the level with fine silver sand; then give a gentle watering to settle it and make it firm; and while that is taking place, look out for and make the cuttings; choose, as I said before, young weak shoots, and cut them off close to a joint, dress off the lower leaves so as to allow about an inch to be planted in the sand, and not more than three or four leaves at the top. Plant them with a short stick, pressing the sand closely to each. The pot may be filled with cuttings in rows across it, or, if space is plentiful, place them out round the edge; I prefer the latter method, if circumstances will allow it, but it is not absolutely necessary; for I have now a pot of cuttings, well-rooted, of the true Shrubland Rose, planted and growing all over the surface of the pot—these were put in last August. As soon as the required number of pots are filled with cuttings, observe that the holes made by the planting-stick are filled up with dry sand. Dry sand is mentioned, because it runs more readily into the holes than moist sand would do; then give a gentle watering again, which firmly fastens the sand round each cutting; leave them on the bench for an hour to dry off the surface moisture and any that may be standing on the leaves. After that time, or thereabouts, place them, if in spring, in the gentle hotbed, or, if in summer or autumn, in the pit or frame; shade from bright sunshine, and water when the surface becomes quite dry. In spring and autumn this will seldom be required, but it must not be neglected. A celebrated propagator has often told me, that the proper and judicious watering of cuttings was the grand secret of success in propagation of all kinds of plants, whether hard-wooded or soft-wooded, from the most delicate Heath down to the easily-struck Tom Thumb Scarlet Geranium; and he was quite right. There are more cuttings destroyed by untimely and injudicious watering, than by any other (excepting scalding by too much heat) point of propagation. Therefore, mind the watering-pot, and do not use it too freely upon cuttings until they are fairly rooted, and show evident signs of having made roots and growth. As soon as these appear, give plenty of air, and expose them fully. The spring and summer cuttings should be potted-off immediately when rooted: but those struck late in the year may remain in the cutting pots through the winter, if room is scarce. When they are potted, let the season be when it may, they should be placed in a frame or pit, where they can be shaded and kept close for a few days, until fresh roots are produced; let them then be gradually inured to bear the full light and air.

Propagation by Seed.—The grand object of propagating by seed is to obtain improved varieties; and in order to increase the probability of success, it is advisable to hybridize. Bees and other insects do this for us to some extent, and many cultivators are content with this natural hybridizing; not so the more scientific operator. He observes the deficiency in some property that an otherwise desirable variety possesses, and endeavours to supply or obtain that wanting property from some other variety that has it. This is done by cutting off the pollen cases from one flower, and supplying pollen from the one whose qualities are desirable to infuse into

the one operated upon; and to prevent the insects from bringing any other pollen, the impregnated flower should be covered with fine net muslin. Seed thus obtained is truly valuable, and is almost certain to produce superior flowers. The seed should be gathered as soon as it is ripe, and be carefully cleaned from the seed-vessels, and kept dry and cool through the winter. Sow it in the spring in shallow pans, placed in a gentle hotbed, or on a shelf close to the glass, in a warm greenhouse or propagating-house. When they come up, prick them out in similar pans, rather thinly. This can scarcely be done too early, for if allowed to remain too long in the seed-pan there is great danger of their damping-off. When they have made three or four leaves, then pot them singly into thumb-pots; and as soon as there is no fear of frosts injuring, then plant them out in a nursery-bed till they flower, and choosing such as are really good, throw the rest away.

T. APPLEBY.

(To be continued.)

WALKS AND EDGINGS FOR SUBURBAN GARDENS.

(Continued from page 88.)

IN continuation of the subject of Suburban Gardens, which last week we left in a simple, roughly-trenched-over manner, it becomes now a duty to study the direction of walks, the disposal of trees, and other things.

Walks, in a general way, run in lines parallel to the outside boundary, if the latter be straight, if not, the walk must not be forced to take every abrupt turning which circumstances may have given to the fence, but may be carried a considerable distance away from it, rather than give those intricate "ins" and "outs" which descend into "the frivolous;" and the direction being fixed on, the formation is next. This subject has attracted much attention of late, some great authorities asserting, that a foundation of more or less depths of rough stones, &c., was not only unnecessary, but absolutely hurtful, and insisting on the walk being composed of a few inches of concrete, asphalt, or some other mixture analagous to them; the advantages of this description of walk, they say, is a smooth, hard surface, and the prevention of weeds. Now this latter qualification is really of less importance to the suburban gardener than to that of the country gentleman; the former, having but little ground to operate upon, rarely grudges the labour it costs, if he takes a delight in it: while the latter may, in other respects, be so taxed, as to be anxious, by all legal means, to get rid of this impost. On the other hand, the materials for an asphalt or concrete walk are more generally at the command of the townsman than of the country horticulturist; the former, surrounded by all the substances required, can readily obtain some one to lay them down in a mechanical manner, which, if done well in other respects, may serve many years; but I never saw any yet that perfectly pleased me: the unyielding hardness is such as to be painful to walk upon, when slightly covered with fine gravel, as is usually the case, and the small stones, about the size of beans, are unpleasant (to say nothing else) for tender feet, while, in wet weather, the imperious nature of the walk renders the fine portion of loose stratum at top, a sort of puddle, which remains so until the superabundant moisture is carried off by evaporation. Now these evils are not easily overcome in those mechanically-formed walks, even when they are done in the best manner; while it too often happens, that the absence of something in the affair, or the undue presence of something else mars the whole matter, and the walk breaks up in flakes. If, therefore, good gravel is to

be had at anything like a reasonable rate, I would advise the amateur to have recourse to the old, but time-honoured way of making walks, as practiced in years gone by. The site being fixed, and the edging, if of box, planted, some little excavation will be necessary. Six inches will do, unless there are other reasons for making it deeper—as the obtaining the soil from its foundation, or the burying of rough stones and other materials otherwise difficult to get rid of. In that case, any depth you like may be gone into, taking care, as you advance to the top, that smaller and closer fitting ones be used, and, what is equally important, those to which worms have an antipathy may then be more freely used, and brickbats, or small stones, with mortar adhering, or mortar, in some shape, may be thrown in amongst the stones. Clinkers, or rough cinder-ashes, are equally obnoxious to this class of underground enemies: but whatever is used, be sure that a fair share be added, as nothing disfigures a walk more than unsightly worm casts, and nothing is more likely to prevent this disfigurement, than the abundance of such offensive substances as noted above. Rough gravel will follow next, and then that which is firm. Now, though gravel may be said to be requisite, yet I have formed very good walks without it; two or three inches of rough stones, like road metal, being covered with coarse black (or any other coloured) sand, so as amply to hide all the stones, and the surface being rolled and made smooth, about an inch or so of white shells was laid on: this makes, perhaps, the most pliant walk of any, the shells soon getting broken, and every shower washing them to the top, making the best appearance of anything for walks, and after rain, or even when it is raining, they are in better order than at any other time; and weeds are more easily removed than when on a hard, firm-setting gravel. I would strongly advocate the use of shells to all who are within reach of them, and they are conveyed very cheaply to all parts accessible by water communication.

Temporarily with the formation of walks is that of edgings, which, in a suburban kitchen garden, cannot be better than of box, which thrives in most situations; a brick, or other fancy kerb-edging, is sometimes used, but the abundance of other objects of a mechanical nature renders something green a relief to the monotonous lines of brick and mortar. Box-edgings will not, however, thrive in every situation; I have seen it planted with its roots laid into the border, instead of the walk, as is usual, and it still refused to grow well, dying off in frequent large patches. In some soils the conditions necessary to insure the welfare of this and other things may be absent, hence the failure. Now these peculiarities cannot properly be expressed by the terms light, heavy, or medium soils, because I have seen box-edgings thrive in all these, and when the two opposite are at the greatest extreme too; the cause of failure then lies in something else than is commonly understood. Neither has barrenness anything to do with it, because I have seen box-edging languish and die where the ordinary garden vegetables were flourishing and thriving as well as could be wished; however, I advise the amateur to try box, which, though occasionally refusing to grow as above, yet is, in a usual way, as much to be depended on as any thing that is planted. It may be planted at all seasons, but dry hot weather is the worst. I am against cutting any of its tops when planted, unless it be very jagged indeed, in which case a little may be cut away; the roots may, however, be pruned into order, and if dry weather follows its planting, watering may be resorted to with advantage; and in following up this subject I may remark, that I rarely clip box-edging more than once in the season, which is about the end of May or early in June, or it may be the latter end of that month, if showery weather does not intervene before that time, as that is of more real importance than the state of the

plant. This period, as will be seen, is just about the middle of the summer growth, and consequently an unfavourable time to cut it with regard to the plant's welfare; but if the weather be dull and showery for a few days it soon overcomes that, and recovers so as to make a few short fresh shoots during the season, just sufficient to break the raw clipped appearance a new cut edging has, as well as to give it that healthy green look which contrasts so strongly with the rusty brown one it often has when cut at an unfavourable season. Next to box, thrift forms a cheerful looking line of edge, only it must be replanted every two years. *Gentianella* will do in some places, but it does not do in every case; double Daisies are also used with advantage; but I dislike Strawberries, London Pride, Thyme, and other large growing plants, as unless the walk be very wide and long too (which suburban gardens rarely are) these are certainly out of place. If the above smaller growing plants cannot be made to grow, then a kerb or other mechanical edging must be adopted, of course, which ever one be used, it is imperative that it should be laid down the same time as the walk is made, in order that the latter be no more disturbed afterwards. I have not mentioned turf edgings, which rarely find their way into a kitchen garden, unless where the walks are of that material, which, however, is unsuitable to the small spots designated suburban gardens. The preparing of ground, and planting permanent vegetable crops will be given next week.

J ROBSON.

VISITS TO SOME OF THE CHIEF POULTRY-YARDS OF ENGLAND.

(CAPTAIN HORNEY'S.)

How many and how various are the thoughts which crowd upon the memory at the bare mention of the name of Knowsley, the baronial residence of him who sways, as his ancestors have often before contributed to sway, the destinies of Britain. But it is of themes other and humbler than those which these historical recollections conjure up that we, who write for the naturalist, the amateur, and the fancier, are destined here to speak. It was at Knowsley that the late Earl of Derby formed, by the labour of a life, that magnificent collection of birds and animals to which science owed so much; which was unequalled as a private menagerie, and surpassed by few, if by any, public establishments of the kind; and which, for the pure love of science, his lordship kept up for a series of years on a scale almost regal. Alas! that we should, with a passing tribute of regret, have to record that his unrivalled collection is numbered "among the things that were," having been, by the unrelenting hammer of the auctioneer, distributed over the world.

Subjects for our humble pen have, however, as it were, arisen from its ashes, for a beautiful and varied assemblage of domestic poultry now occupy some of the enclosures where all that was rare and gorgeous in the feathered creation were once, as we have said, collected together.

Who, of those who have attended the poultry shows which have long existed in the north of England, and which, on account of the increasing interest taken in the objects of them, are extending themselves rapidly throughout the land, has not heard of the name of Captain Hornby, and admired the specimens which he has exhibited? It is to these, then, and to a description of their dwelling-places, that we propose to devote the present paper.

The hospitable cottage of the gallant captain is situated about equidistant from the mansion of Knowsley and the Huyton-gate station of the Liverpool and Manchester railway. Here is a convenient, but rather confined, poultry-yard, of which as much as possible is made, after this fashion which we describe fully for the benefit of those whose space may also be limited. A plain brick building, fronting to the south, and having a roof leaning northwards, is (we speak from recollection) from twenty to thirty feet long, by six or eight wide. Of the height of a door behind, it rises towards the front sufficiently for the lean of the roof. This is di-

vided into three compartments, each ventilated by a kind of wooden chimney, which admits air, but excludes the rain, and the inside is furnished with nests and low perches. On the south side, a small slide, closed at night, allows ingress and egress to the fowls, and on this side are three enclosures, corresponding to the three compartments of the building. These are formed of light, but strong wire, well painted, and may be twelve or fourteen feet long, by eight or nine wide, an alley, or passage, of two feet in width, or thereabouts, permitting visitors to look at the birds, while it prevents them from fighting through the interstices of the net-work. A daily supply of sand, which is obtained close by, keeps all healthy and sweet, and the cleanly appearance of the whole does much credit to the handy little girl who has the care of the poultry located here. Three lots of Cochon-China fowls at present occupy the enclosures we have described. They are bred, we believe entirely, from the stocks of Mr. Sturgeon and Mr. Andrews, and do credit to the races from which they are sprung. They are let out, alternately, for a few hours each day, to roam over the yard and a field adjoining; and thus, while intermixture is prevented, have the full benefit of an extensive walk. To those whose space is small we strongly recommend such an arrangement as that which for these reasons we have described; for it is obvious that three or more varieties of poultry may, by these means, be kept perfectly distinct in a locality somewhat confined. The building is by no means an expensive one, and we anticipate that many young fanciers will be indebted to the Captain for enabling them, by building upon his plan, to extend the varieties of their feathered favourites.

Accompanying our friendly host in a short walk across the beautiful park, which affords, by the way, a view of the noble mansion of Knowsley, we reach some of the enclosures of the quondam managerie. Here is the splendid collection of Spanish fowls which Captain Hornby, almost regardless of expence, has formed; and we do not hesitate to say that, good as are the specimens of his other varieties, these are, beyond doubt, young and old, the flower of his flock. Whoever beats him at Birmingham must have first-rate birds, and shown in first-rate form too. At another place, in that which was once the pheasantry, are his young Cochons, a promising lot, inhabiting splendid quarters. Another walk, equally pleasant and diversified, brings us to a farm-house where one of the game-keepers resides. Here are the Dorkings, turkeys, geese, and Aylesbury ducks, and it is difficult to award the palm where all are of great merit. The speckled Dorkings would do credit to any exhibition, and will be difficult to beat wherever they may be shown. Some other enclosures, at convenient distances, are appropriated to other varieties, all of which must, with the care devoted to them, flourish in walks so healthy and extensive.

Few amateurs can hope, as this imperfect description will show, to possess the facilities which Captain Hornby enjoys for the keeping, each in its purity, of so many varieties of poultry. The arrangements made at his own residence show, however, how easy it is, in a space comparatively confined, to keep two or three distinct breeds. With these, the prudent fancier will be content, preferring excellence in one or two to mere variety of mediocre races, and thanking those few who possess extended means for enriching our exhibitions with the greater number.

That the taste for the pure breeds of domestic poultry is extending itself, we have had repeated occasion to state, and our assertions are more than proved by the increasing numbers of exhibitions and of the varieties shown, as well as by the large prices which first-rate specimens, even of the oldest varieties, still command. Many of our most enthusiastic amateurs are compelled, by space and circumstances, to confine themselves to one variety; and in proportion as their judgment and care are concentrated on a single point, is oftentimes to their success in the production of excellence in that particular breed. To such be all honour, for they do all that their means admit, and even more than, at first sight, such means would appear capable of effecting. But while we give full credit to him who, with slender means, does all that his limited opportunities are capable of performing, it is but fair to accord a larger meed of praise to the fancier who, more fortunate, it may be, in the possession of extended means, yet with increased trouble, anxiety, and toil, effects proportionably greater results. We know of no

one who, on the whole, is better entitled to the credit of having done his utmost, with much judgment, and regardless of trouble or expence, to promote the excellence, and extend the benefits of our best breeds of domestic poultry than Captain Hornby. Thanking him for the urbanity and kindness experienced by ourselves, we anticipate an agreeable and instructive visit for any one who is equally fortunate in obtaining an inspection of the poultry yards at Knowsley, "and so we say most heartily farewell." B.

EATABLE FUNGI.

(Continued from page 14.)

PROBABLY as an article of diet none of the fungi have been so generally and highly esteemed on the Continent as the *Morells*. There are several species of them, and the whole genus is considered free from poisonous properties; some, however, are insipid, and barely eatable; while others, to which our attention will be more especially drawn, as *Morchella esculenta*, *M. patula*, and *M. deliciosa*, are truly excellent.

In Germany they are largely used, and are considered the most delicate and valuable of the fungi; they are seldom eaten alone, or cooked when fresh, but are dried, and in this way may be kept for months or years, and are largely employed in soups, sauces, or gravies, to which they give a high and rich flavour. There are a variety of ways of dressing these most delicious fungi. Paulet gives directions for stuffing Morells with savoury meats, such as pickled pilehards, cray-fish, the flesh of fowls, &c., and says, after they are boiled they are to be served up with champaign, lemon-juice, and bread-crumbs! Persoon, also, gives the following receipts:—

STUFFED MORELLS.—1. Choose the whitest Morells, wash and wipe them well; when quite fresh-gathered, open the stalk at the bottom and fill it with veal stuffing, anchovy, or any rich sauce you please, securing the ends, and dressing between thin slices of bacon. They may be served with a sauce of rich gravy, &c., according to the palate.

2. Having washed and wiped the Morells as directed in the last receipt, stew them for an hour with a piece of ham, and a little parsley, pepper, and salt, adding occasionally a little broth to prevent burning, and when sufficiently done, bind with the yolks of two or three eggs, and serve on buttered toast.

THE LYCOPERDONS (Puff Balls) form another genus, affording abundance of delicious food in many countries, where they abound and spring up after showers with incredible rapidity, some of them attaining enormous dimensions. In Italy and India they are esteemed as great luxuries. The smaller ones may be stewed in a rich beef gravy, either by themselves, or with other esculent fungi, where they are scarce, and may be flavoured with lemon-juice, &c., according to taste. The best method of dressing the large sorts, as *Lycoperdon bovista*, is to cut it in slices, and fry it in fresh butter, with eggs and bread-crumbs. So prepared, it has the flavour of a rich, light omelette; or, as others consider, the flavour of sweetbread. No fungus, says Dr. Badham, requires cooking so speedily as the *L. bovista*, which grows to an immense size, and as it has the power of quickly repairing injuries (being one of the most rapid of the fungi in its growth), Dr. Badham has recommended, where it is found near our domestic dwellings, that a fresh slice should be taken, from time to time, from each fungus, as we require it for the table; for if allowed to remain undressed it soon decomposes, and becomes insipid and unwholesome. When perfectly fresh it is one of the lightest and easiest of digestion.

THE TRUFFLES form another genus equally sought after and esteemed. They vary much in size and colour, being found from nearly white to a dark brown or black. They have a peculiar odour when fresh from the ground, soon making a room, to most people, unbearable, and they will even scent a house for weeks, if allowed to remain exposed in their fresh state, as I experienced when collecting the eatable fungi for the table, while residing at Basingstoke. They are found abundant on the Continent, especially in the south of France and Italy, from whence it is supposed

they are imported into England in large quantities. They are also found in the East Indies and Japan. They are principally used to flavour soups and sauces—(and, in my opinion, may be dried and kept for months or years, and used for the above purpose grated like nutmegs). If dressed in their fresh state, they should be simply washed and boiled in *plain water*, and served up on dry-toast, peeled at the table as potatoes, and eaten with bread and butter, and pepper and salt, in which way they make a good wholesome supper. I have eaten them raw, cut in thin slices and laid between bread and butter.

THE *HELVELLAS* form another genus free from poisonous species, although some are much more highly esteemed than others—some being insipid and tasteless. *Helvella crispa*, *H. lacunosa*, and *H. esculenta*, are the species most esteemed on the Continent. Their flavour is very similar to that of the Morells, and, by some, the *H. esculenta* has been taken for the true Morell; and, in many instances, they are passed for it. They are, undoubtedly, inferior to the Morells, and, unfortunately, are of a tough, leathery, consistence, which, however, is somewhat remedied by soaking them for a night in milk, and afterwards stewing them for some hours. The best way to dress them appears to be—to stew them for four or five hours in a good supply of rich gravy. My method of dressing them was first to chop them as fine as minced veal, then to cover them with plain water in a saucepan, and stew them for about three hours, adding occasionally, for the last hour, flour from the dredger, and fresh butter, pepper, salt, and lemon-juice, to flavour them. They were then served up with dry toast. They are very excellent stewed and served up with hashed mutton.

THE *CLAVARIAS* form another genus producing no poisonous species, and many that are esteemed luxuries. They are a very handsome genus, varying much in colour, which renders them attractive to the collector, and, when preserved in brine, for sale. They are abundantly introduced into the Italian markets, and in many parts on the Continent are highly esteemed as an article of diet. The following receipt for dressing them is given in Dr. Badham's treatise of the *Esculent Funguses of England*. They are first to be stewed with a little butter over a slow fire, afterwards to be strained, then (throwing away the liquor) to be replaced to stew for an hour with salt, pepper, chopped chives and parsley, moistening with plain stock, and dredging with flour occasionally. When sufficiently cooked, the whole to be thickened with yolks of eggs and cream.

The following *Clavarias* are most esteemed—*Clavaria rugosa*, *C. pyxidata*, *C. cinerea*, *C. flava*, and *C. coralloides*.—F. YORKE BROCAS.

(To be continued.)

HONEY-HARVEST ON THE MOORS.

I HOPE it is not too late in the season to invite our apian friends to accompany me, in imagination, on a visit which I had an opportunity of paying early in October, to (I believe I am correct in saying) the largest bee-keeper and honey-dealer on the Northumberland Moors, and I think there are few among them who will not learn something from a description of his autumnal management. Being an old acquaintance, I was soon ushered into the *sanctum sanctorum* of the establishment, the upper apartments or lofts of the house. Around the first room were ranged a number of empty hives, home-made, and all cottage hives, of various sizes, heaps of refuse combs, and, in a recess, piles of the purest heather honey, sealed up in paper equally pure, ready to be dispatched to customers in all parts of the kingdom.* But the point of attraction to the eye of the apian was a row of hives, reversed, and full of combs, containing a large quantity of honey. A glance, however, showed these had not been arranged by their neat artificers; the edges were uneven, many of the centre combs filled with honey, and the side combs empty. In fact, they had been made up from fragments, from such combs as, having contained brood, were unfit for sale. These combs were fixed in empty hives by two small round rods,

* The price of this honey has this season been 1s. 3d. per pound.

thrust from one side of the hive, through the combs, to the other, and thin narrow laths were placed perpendicularly between the combs, to retain them in their proper position; in the evening these were to be tenanted by driven bees. Thence we proceeded to the driving apartment, which was lighted by a small closed window at one end. Here were four men engaged in the operation of driving. Our readers are aware that this is attended with some difficulty when the air has become chilly, and, before this time, the thermometer had fallen at nights to 33°, whilst the Cheviots the following morning were capped with snow! The bees had been brought from the moor about a fortnight previously and placed in the garden, that the brood might be hatched out, and drones were still found in many of the hives. The driving was commenced in the usual manner, an empty hive being placed over the full one, and a cloth bound round the junction. In about ten minutes, when a portion of the bees had ascended, there was a departure from the ordinary mode of driving. The hives were then divided, the upper end being held in a slanting position, and at one point forming a junction with the stock, while the bees, now intimidated and in confusion, were guided and brushed forward with a feather from among the combs. At this stage of the proceedings, the queen not having always ascended, the bees in some hives went streaming briskly up, while in others, their connection between the two hives was, at times, entirely broken; but, in answer to my inquiry whether they did not sometimes entirely fail in dislodging the bees, I was told, that though sometimes it was tedious, and required patience, the hive was *never* left till it was clear of bees. A few flew to the window, and to the owner of only four or five hives they appeared a considerable number, amounting, when several hives had been taken up, to about half-a-pint; but these were gradually grouping in clusters, and in the evening were to be joined to others, for not a life was willingly sacrificed. These hives had only stood the summer; and the object being to obtain as much pure honey as possible from the side-combs, they were mostly of a very large size; the largest eighteen inches in diameter, by thirteen deep, had received a large swarm, which, having been joined by part of another swarm, weighed seven pounds, and, on its return from the moor, the contents weighed five stone, exclusive of the bees. In driving such a hive, the support of the cross-sticks would be almost indispensable. Those intended for winter stocks were much smaller. Families which were not very numerous were to be limited, one queen being removed, and the other retained, according to their merits, for a brief history of the time of swarming, &c., was labelled on each hive.

We next visited the garden, about a quarter-of-an-acre of ground, divided by fruit-trees into four compartments, around which were ranged the hives, and of which the winter stock would be above fifty. While some were inactive and still, others were all bustle and excitement; these were the manufactured colonies, still reversed, with the empty hive tied over them. In about ten days, the combs would be securely fixed to the sides and top by the bees, when the upright props would be removed, and the hive be placed on its winter stand.

Such is the autumnal management which the experience of a long series of years recommends as the most *profitable*. This consideration will demand no advocacy; but surely there are others which should be as potent. If any of our readers still pursue the old and cruel system, will they not pause and reflect before they again apply the brimstone match? Is there not enjoyment in existence to the least in creation? Are there no feelings of gratitude and affection towards our little garden companions, whose active industry has afforded us so much pleasure and amusement, and whose toils may, probably, have contributed to our luxuries? For myself, I re-echo the words of De Gelien, "Je ne les aime pas médiocrement, je me passionne pour elles."

Before laying down my pen, I will make one or two remarks on the accounts furnished by correspondents of THE COTTAGE GARDENER, and for which we owe our thanks, for there are lessons to be learnt from failure as well as success. In the apiaries of "B. B." and "H. T. N.," drones in September are sure signs of mischief of some kind. Liberal feeding might stimulate the bees of a queenless stock to carry pollen, but the problem may have another solution. Are the drones full-sized or dwarfs? If the

latter, there is a queen, but she lays the eggs of drones only. Should "B. B." now join bees with their queen to No. 2 (and I have visions of a palace in ruins, next spring, under the earthen pan), this queen must be dislodged a few days previous to the union. But it appears that "B. B." has had several dislodged families at command, and I would ask, if he has never presented a spare queen to this auspicious hive? Had it not possessed a sovereign, a stranger would have been welcomed with an enthusiasm which might have awakened feelings of envy in the breast of the French President! Does not "H. T. N's" hive No. 1, which is Mr. Taylor's bar-hive, afford facilities for a thorough examination of the combs and bees, by taking out the former on the bars, and so ascertaining its state as regards the queen? In reading the account of the "deadly warfare," my first impression was, that there had been a mistake as to the hive that had swarmed, but to this difficulty, I think, another explanation may be given. It is observed, then, that in summers when honey is very plentiful, bees assimilate readily, swarms unite, and even enter other hives; but in times of scarcity, all their feelings of jealousy, as well as the desire of plunder, are awakened; and, judging from the returns in this apiary, the secretion of honey in the flowers this season had been very small.—INVESTIGATOR.

THE POTATO MURRAIN.

You perhaps will excuse a casual reader, but a close observer, although only a humble individual, addressing you upon the disease of that *root* which, to the poorer classes of society in Great Britain, may be very justly denominated the STAFF OF LIFE. I see, in a recent number of your publication, a very pious letter on the history and culture of the Potato in this country, but ascribing its disease to the introduction of guano. It will be well remembered by many in different parts of England, including Ireland and Scotland, that long before guano was introduced, or even known or thought about, a disease infected the Potato, but more particularly at the planting season, or just after planting, among the sets, which disease was then commonly known as the *dry rot*. It was no uncommon or isolated thing to see only parts of a field or furrows come up. Upon examining the sets that did not vegetate, most of them had entirely decayed, and only the outer skin was left. Various reasons were advanced, and plans suggested, to cure this disease, or prevent a recurrence, such as planting as soon as cut, or substituting a whole potato for a set in lieu of a cut one, in order to prevent the lymph, or *water*, escaping—a system which is now very much followed. You will excuse my simple language, as I wish to make clear what I write to the simplest capacity. I trust to be enabled to show that the disease I write of, dated some eighteen years back, when we had no guano, bears an analogy to the present murrain. Even prior to the above period, I have known the potato slightly diseased at taking-up time thrown aside as not being good and no further notice taken of it.

It seems something singular that the whole science of Europe, practice and theory, philosophy and chemistry, have not yet discovered the cause of this plague, even with the assistance of Moore's and other almanacks to help them. It appears this year, in this island (Thanet), to be nearly as bad as in 1845. Seven years' experience, with the whole of the knowledge of the "Royal Agricultural Society," and prize essays to boot, and no effectual cure or remedy; nay, not even the cause discovered! Eminent practical gardeners and amateurs, down to the veriest clown, all baffled. Surely this is a wonderful mystery; but so it is. Doctors differ, and so do diseases; yet doctors, to cure this, have not been wanting by thousands, with innumerable remedies: but *all have failed*. If the blind lead the blind, both must fall into the ditch; so must all prescribed nostrums, unless the cause of the disease is first discovered; it appears to be making a beginning where it ought to end. You will excuse my using the plain word potato instead of tuber. Honest John Hodge's conceptions are sometimes curious, and his ideas not exactly clear upon all things; he might take it for a new-fashioned drain tile, or, mayhap, he may think it is to grow long Kidnies in, like them gardener chaps

do cucumbers, to exhibit at the flower shows. I am rather surprised to see, in No. 213, Oct. 28, that you are content to let time correct the evil of this plague. You say, "No doubt but that the Potato will one day be restored to them in its original purity, however long the ordeal through which it has to pass: a cure is out of the question." With this I beg to differ: it looks so like despair. I would have shown the original cause of the disease long ago, and without which *time has proved there is no cure*, but those to whom I wrote about it gave me no encouragement; it was left to that ordeal through which it has already passed, and which is yet in store for it. Nevertheless, I will write you another letter (if this finds room in your little publication), and showing the analogy to which I have adverted.—A CASUAL READER.

[Mr. Errington was quite right when he said "a cure is out of the question;" for when the disease attacks a tuber, who will undertake to restore that tuber to health? *Prevention* is what we must strive for. We shall be very glad to receive our correspondent's promised letter.—ED. C. G.]

NORMANDY.

I TAKE UP my pen—as housemaid's say when they write to their sweethearts—for the purpose of sending you a few memoranda on the poultry of this ancient province; but so little new or interesting in that line have I seen during a complete journey through it from east to west, that, although the said pen is a magnificent Canada goose quill from Hudson's Bay, worthy to write an epic in twenty-four books, I shall have to lay it down again before we get to the bottom of the column, unless you permit me to introduce a few other matters which have reference to country life.

As in the Calaisis, all the fowls are a medley of breeds, with here and there some one race predominating in its own locality. In the Pays de Caux, the district extending along the sea on the north of the Seine, the *Spanish* type has the mastery, though nothing like a well-bred Spanish fowl is to be seen. Around Caen, on the other side of the estuary, the *Polish* are in the majority. There is a very large exportation of poultry from the department of Calvados *via* Havre-de-Grace (as I like to see it written); and an inspection of the fowl-baskets, as they are landed from the numerous little steamers, which arrive from Honfleur, from Trouville, from Dives, from Caen, and from Isigny, will treat you to the sight of a great variety of Polish fowls, some with better top-knots than I have seen exhibited at Poultry Shows. You will find bearded, beardless, whiskered, and muffed specimens, black, white, brown, and speckled; so that those original virtuosi whose passions are excited about the beards of Polish fowls, may each select his own particular idol, and fall down and worship it. The poultry of Normandy is famous for its excellence on the table, and after having partaken of an admirable pullet, with watercresses, a philosopher will not spoil his digestion by insisting too positively that she would have been infinitely better with, or without her beard, as the case may be, and as his choice may lie.

The *Turkeys* are still the pure black Norfolk breed, which is so generally cultivated, and varies so little that the race acquires from the circumstance an additional importance in natural history. Was it *the* domestic variety originally imported into Europe? In one respect we perceive the influence of climate; the poults are earlier for the table than in England. Fine birds may be had in August at a moderate rate, and in September they are abundant.

The *Pigeons* also are very large, mostly of a Runtish character, with a dash of the Trumpeter. They are also numerous, and exceedingly domesticated. Blue Rocks and Dovecote Pigeons are less common, and, indeed, are seldom seen. The Cotentin, the rich luxuriant peninsula which extends from Carentan to Cap de la Hague, produces more *Geese* than I had before observed in the north of France, and also makes the most of them; for many of the poor things wandered about half-naked, having lost their feathers by a less easy process than that of moulting.

The most *unlikely* spot in which I ever saw poultry located, was the Digue, or Breakwater at Cherbourg, a gigantic work, of which that at Plymouth is only a reduced copy, so to speak; the one being 4111, and the other 1760 yards in

length. When finished it will have cost seventy millions of francs, or nearly three millions sterling, and is not dear at the price, if we consider the labour it has cost, and the services it renders. It forms a harbour, and protects a bay which would hold almost all the shipping of Europe. It is perfectly insulated, and is built entirely of granite. In the centre is a lighthouse, with suitable habitations for the officers and workmen, *five hundred* of whom reside upon the Digue. From this centre two vast granite arms stretch right and left, each terminating in a large circular fort about half built, but on each of which forts the workmen who labour there live and sleep in temporary wooden buildings; for when the sea is rough, driven by a strong north wind, the arms are impassible; the waves dash over them, and sweep with such violence, that large blocks of granite many tons in weight, which happen to be lying there to complete the edifice, are born away into the bay like pebbles, or dashed together and broken.

On approaching the Digue in our boat, as the lighthouse and central buildings became gradually more distinctly visible, I was prepared for their human occupants, but did not expect to find any of the brute or the feathered creation colonising a more hard bare wall of granite, without soil and without vegetation. However, let man go where he will, he is sure to be followed by certain companions, attendants, and parasites. The natural history of the Cherbourg Digue would be a curious little memoir to draw up: it would remind one of the *Fauna* of those desert islands which Professor Henslow named "Refuges for the Destitute," in respect to their zoology and their botany. Even before we landed, some cocks and hens came forward to display themselves, and strutted along the sharp, straight brink of the Digue. How they contrive to amuse themselves all day long it is impossible to guess, with no earth to scratch in, no dusting holes to bask in, no lawn to ramble over, no thicket or hedge in which to steal a nest; nothing but granite, at which they may scratch and peck to their hearts' content in vain. Next, a couple of dogs made their appearance, and then a cat stole quietly by; for the Digue abounds in rats and mice. The insect world there comprises fleas, of course, whatever else; houseflies I saw while eating an omelette that was kindly cooked for us. In the summer many butterflies make their appearance, and now and then a bee may travel there by mistake. The list of birds is long; I saw swallows, wheatears, and (would you credit it?) a wren.

The fowls might be luxuries of the great folks in the centre, and would not be looked for among the labourers at either end; but after walking something like two miles on one arm of the Digue, and inspecting the immense circular fort, which was rising block by block, and battery above battery, out of the waves of the sea, I was startled by a familiar crow; and there, down amongst the shivers of stone, and the tools, and the heaps of cement, and the wooden sheds, pranced a cock and three or four hens. The men like to be waked in the morning by the voice of their old country companion; and though the view of the opposite coast is exceedingly beautiful, it is too distant to permit them to enjoy the *noises* which belong to such a rich extent of hill and dale.

Poultry keeping at the Digue is to be criticised in one respect. Fowls in the centre would no more think of visiting those at either fort, than they would of flying to the moon; so that a better place of keeping breeds distinct, than these three localities, cannot be found by industrious searching. But the fowls here are of no breed, or any breed. No one cock resembled any other cock, nor any one hen. It is a complete set of experiments in mongrelism.

The forts being at either end, are specially exposed to tempests. Like the rest of the structure, they are founded on rocks that have been cast into the open sea, and piled up till they rise above the surface. In violent storms, the whole Digue can be felt to oscillate and tremble, though it is believed to be perfectly safe *now*. Every squall only settles the stones more firmly in their places, and additional blocks of granite are continually being thrown into the sea, just before and outside the Digue, weather permitting. The forts are similarly protected and supported by large oblong masses of artificial rock, or concrete, made of bricks, stone, cement, and mortar, tossed into the waves when

sufficiently consolidated. Each block costs 1500 francs, or £60, on arriving at its place, which will give some idea of their magnitude. As the sea is beautifully clear, these gigantic heaps of stone can be seen at high-water, and inspected, when the tide is out.

The granite of which the Digue is built is of a cold-looking, light grey, and comes from the Isles Chansey, in the Gulf of St. Malo; the blocks thrown in, to support the foundation, are red, inferior and coarser, and are brought from Fermanville, a few leagues to the east of Cherbourg. I saw two vessels arrive thus laden, and could not think what made them roll and pitch with such a very peculiar heaviness, till they were moored in their required station, under the direction of the commissary. And then the men began heaving the great lumps of stone, each encircled with a necklace of chains, out of the hold, by means of a pulley and ropes fixed to the top of the mast; each heavy mass was swung as near to the outside edge of the deck as possible, freed from its iron ornaments, and then hoisted over the edge with levers, till it overbalanced itself, and fell into the sea upon the spot intended. It was curious to watch the boiling of the waters, and the hissing of the air-bubbles which foamed up afterwards. The whole process was most laborious, and not without danger; it was anything but child's play. Nor would it be any joke for the lobster who happened to be sporting under water on the exact spot where the Titanic lump of granite was about to fall.

A local egg-story must not be forgotten. A Lieutenant in the French Navy told me, that while he was at Cherbourg, a conjuror, or *escamoteur*, who was paying a professional visit to the town, went into the Market-place, and while loitering there, asked an old woman the price of her eggs. She told him she sold them at six sous a dozen. He said that was a great deal too little, and that she did not know the value of the eggs which she had in her basket. He then took one of them and broke it before her eyes, and showed her that it contained, besides the yolk and the white, a forty franc piece—a large gold coin, sometimes called a double Napoleon. He then broke some more of her eggs, and every one of them contained, or seemed to contain, a piece of gold. While this was going on, he offered to buy all her eggs at *twelve* sous a dozen; if she would sell them, he would take every one of them off her hands. But Madame purse-proudly replied that she was not so foolish as to part with such precious eggs as those, with her eyes open, for a mere paltry offer like that, only double what common eggs were worth. Not she, indeed! She should keep them herself. So he went away, affecting great disappointment at her refusal. As soon as his back was turned, the silly old woman began breaking her eggs, one by one, to make sure of the treasures hidden in them. As she went on, she was greatly astonished that she smashed egg after egg without coming to one with a forty franc piece in it, and so she continued, in the true spirit of gambling, expecting that the next venture would draw the prize, till she had not another egg left. She was sitting, beggared and forlorn, in the midst of a mess of crushed egg-shells, and spoilt custard-meat. Of course she then began to cry, and take on. The other market-women crowded about her, and only laughed at her when she told them of the price she had refused for her eggs, and the reason why she refused it. But the conjuror, who had watched the workings of her despair, took pity on her sufferings, and soon returned; and after having had his laugh too, he paid her market-price for the eggs which he had beguiled her into breaking. And as he gave a performance at the theatre that very evening, the trick he played the old woman served him as a capital advertisement, as he doubtless intended; and he had a crowded house, lots of applause, and sacks-full of money. D.

(To be continued).

WILD BEES.

By W. H. Nemman, Esq.

(Concluded from page 89.)

ENEMIES OF THE WILD BEE.

I CONSIDER the common field mouse by far the most destructive enemy of all wild bees;—wherever it finds their nests it destroys them. I had a nest of the *Apis Terrestris*

in my bee garden two years ago, when suddenly, in July, I missed my friends; they were not at work;—on watching for a few moments, a field mouse came out of the hole, and returned; on examination, every bee was killed, and the combs destroyed. But this is not the worst, for these vermin also catch one-half of the queens in the winter, while they are dormant in the earth, and eat them. The forests of England would be well-stocked with wild bees but for the mice. They say that stoats and weasels are also enemies of the wild bee; it may be so, but I never caught them at their nests; and there is one thing quite certain, that the two last-named creatures kill immense numbers of mice. It is most difficult to kill these mice in the fields; for they are far too numerous and too extensively dispersed to be caught with traps. I think the weasel and the stoat are the bee's best friends in the woods, and the cats near villages. The last, and almost worst, enemy of the wild bee is the school-boy! who is constantly, and has been from time immemorial, fond of killing them for the sake of their honey-bag, and as often for pure mischief, and when this is done, in April or May, a whole nest is destroyed.

I think I am entitled to give my readers these words of instruction when I tell them my acquaintance with the "Dumble Dores" is of fifty years' standing. I commenced catching them myself when a child; the first nest I took, and brought home, was in 1798! the last in 1848!

I hope my readers are not tired of these matter-of-fact details of my earliest friends the wild bees. While acknowledging that I have spent many happy leisure hours in studying their history and economy, I trust those of my readers who are not naturalists will not think the pursuit trifling or unsatisfactory, as many do, who are no lovers of these things. For myself I may truly say, that, to this day, I feel thankful that the first fifteen years of my life were spent in the country, and in these pursuits. The old adage, "God made the country, and man made the town," is to me a true saying, for the agency of a Great First Cause is much more apparent in every object around us in the country than in the town;—even in the history of these little insects, how wonderful their preservation during the winter, their frail bodies being, five months in the year, in the cold, wet earth, and other holes and corners! (I once found one in a small fissure of wooden fence; it was dormant until the beginning of February, when it recovered, and flew away). They rise from their long slumbers, refreshed by their rest, as soon as the sun begins to warm the earth.

The study of the wild bee has this advantage over the hive bee, that young people can follow it without danger; they are not vindictive, and, if properly handled, do not sting, even when defending their young; it can also be followed without cost, except that of time; and who is there that has not a leisure hour each day in the summer? I, therefore, strongly recommend this study to my young friends in the country as an intellectual amusement. Natural history has, of late years, become more fashionable, and this is no mean part of it; besides, it is accessible to nearly all who reside in rural districts; and in the hope it may become so, I take leave of my readers, only adding, that in all the species of wild bees, nearly a uniform system prevails as to the order in the nest: all useless and disabled bees are turned out. Their practice is, "He that does not work, neither shall he eat." Many bees are hatched with defects in their wings, and even without wings, from some disease; these are all turned out to perish. The discrimination of the hive bee in this respect is astonishing. I have often placed a bee, which had defects, on the alighting-board, the guards instantly came up to the intruder, and having held a sort of consultation for two or three seconds, they immediately begin to expel it. But mark the distinction; in showery, cold weather, hive bees are often knocked down and benumbed near the hive, and remain in a state of torpor, from which, if not recovered, they will die of exhaustion. I have a thousand times placed these bees on the board near the entrance, the guards rush out as before, but, on examination, although the bee is unable to walk, they do everything to assist the benumbed insect. By some unmistakable instinct, they directly discover that he has no bodily defects! and admit it into the hive after it has recovered by the heat at the entrance!

In conclusion, we may certainly consider bees as among

the wonders of the natural world. "We know in part," yet how little does each one of us know, not probably a thousandth part of the great volume of the stores of natural history! The whole subject leaves us lost in contemplation at the stupendous nature of that Being who is the projector of them all!

TO CORRESPONDENTS.

ORCHARD HOUSE (J. S., Newcastle-on-Tyne).—Yours is a bold set-out for an orchard house; but why leave the ends and front open? We would close it all but about a yard of superficies at the angle at each end. We would also board the front, leaving a space open in the centre of each light, half-a-yard long by six inches wide; and these might have flaps, with a wooden button, to close in bad weather. Have you no escape for heat at the apex? Your fruit arrangement is not first-rate. Cherries and plums may stand the shade of the back wall, but not peaches. We would do thus:—No. 1, Fondante d'Automne; 2, Marie Louise; 3, Beurré Diel; 4, Winter Neillis; 5, Beurre d'Arenberg; 6, Passe Colmar; 7, Royal George Peach; 8, Bellegarde Peach; 9, Elruge Nectarine; 10 and 11, Moorpark Apricots; 12, Shipley's Apricot. On back, inside, six trees, thus—1 Precocoe de Tours Plum, 1 Greengage, 1 Royal Hative Plum, 1 Early Duke Cherry, 1 Late Duke Cherry, 1 Elton Cherry. Outside, at back, Morellos and Currants alternating. The wood must be trained thinly over the roof, at nearly a foot from the glass. The back trellis should have double distance in the wood. Such is our opinion. We are glad to see these things progressing. Pray consult our articles on "Stations," before planting—to be found in back numbers.

PRUNING BUDDED ROSES (Belle).—October and November is the best time to cut back wild shoots that were, or were not, budded the previous summer—then to be cut within six inches of the inserted bud. "The best time for cutting them again," meaning these six-inch stumps, is the beginning of next July. The reason for leaving the stumps is to fasten the young shoots to them which would otherwise snap off with the first gale. It is of no great consequence whether you disbud the stumps or not, but you must stop all shoots from eyes of the wilding, above and below the inserted buds, at the first or second joint, the next season after budding. November or February is the best time to manure them, but manure never comes amiss to them. Cow-dung, so decayed that it will cut like soft putty, and mixed with one-third chopped fresh turf from a good pasture, is the best manure for them.

UNIQUE GERANIUM (S. S.).—February and March are the best months for striking this geranium in heat. In July it strikes freely, full in the sun, or behind a wall; we prefer the sunny side, and a little shading at first. "In a small way," a one-light box facing the south, and having six inches or a foot of light sandy compost, is the safest way to get July cuttings of this and several of the dwarf and delicate sorts. This could be shaded for awhile till the cuttings could stand the sun. The objection to a north aspect is, that if the autumn happens to be cold and wet, cuttings will not strike so well.

WHAT IS POOR SOIL? (S. S.).—All kinds of light, sandy, and gravelly soil, with little or no dead vegetable or organic remains in them; but "soapy clay" may be very poor soil indeed, although not in the sense we use it for flowers. Sand will make any soil poor enough for flowers, and leaf-mould will make any soil rich enough for them, if sufficient quantities are used. The quantities can only be known by inspection.

CAMPANULA CARPATICAS (S. S.).—They never flower in May at all, but from June to September. The Roses *Microphylla* and *Maria Leonide* are not pegged on the principle we object to; they are climbers, and all climbing roses may be trained on the face of the earth, just as well as on the face of a wall, and pegs will then do for nails. Many thanks for the news that these two Roses make beds that flower from May to October in Hants.

FAST-GROWING TREES (A Subscriber, Bromley).—On your light gravelly soil the White Poplar, and the Turin or Lombardy Poplar, are the best to get up quickly to hide the "ugly cottages." For covering wire-work round windows facing the north, no plant is so good as the *Cotoneaster microphylla*, but being a slow grower at first few people use it. Others object to *Ivy*; and then the next best are the evergreen climbing Roses, such as *Myrianthes*, *Princess Maria*, and *Felicite perpetuelle*.

BULBS (S. S. S.).—Many thanks for the remainder of the list; we shall go through the whole of them this winter.

DATURA (Shylock).—A Datura that is only a foot high by the middle of October will not do to be left out this winter, nor next winter either; and it is of no use to dry it and try to save it that way, as it is too young for that experiment. Therefore, as you have no greenhouse, nor pit, nor any space in the house, you have only two events to choose from. Either get a friend to keep it for you in his greenhouse, or let the first smart frost destroy it, and buy a better, or, at least, an older plant, next May.

FLOWER-GARDEN PLAN (W. P. H.).—We recognised your plan the moment we opened the letter. Were it not for the excrescence caused by 8—3, and by 9—9, this plan would be quite faultless in design. There never was a plan more easy to plant and manage than this, and the wonder is how you could possibly contrive to go wrong with it. You were probably misled, trying to imitate the planting of the designer. Committing a fault to escape the consequences of a misfortune put you wrong the whole season. The autumn-sown annuals perished, and to make good their loss you sowed more annuals in the spring, in the very beds where the summer plants were to go. Did any mortal body ever hear of such a daft trick before! And what is the use of asking for our advice now, when you positively do just the contrary of all that you have read in these pages already? In the first place, what was to hinder the removal of the bulbs when the time came for the other planting? No reason whatever. In the second place, try again, and keep to the advice of one book only, and then you will be right. Every book is right according to some notion or other, and every amateur is wrong in trying to work out more than one system at the same time and in the same space. Look to the index for all you want for the fresh start, and after that let us hear from you again, and we engage you shall be right this time.

FLOWER-GARDEN PLANS (A. P.).—We are obliged to keep the engravings to the smallest compass, and to lay down our series to a uniform scale would be worse than useless. No. 1 is applicable to a space of one-quarter-of-an-acre, and not too small for four acres, with suitable accompaniments. You had better not be in too great a hurry, however, till you see a few more of these designs, which will be as various as our stock will afford.

FUCHSIA SPECTABILIS (A Subscriber).—This is a strong two-year-old plant, and has not yet bloomed. Let it have fair greenhouse treatment, and you will probably have bloom in two or three months or sooner. If you do not succeed, you may then in summer plunge the plant under a south wall as you propose; though we have known it fine set against a north wall in summer, and brought into the house in autumn.

TORONIA ASIATICA SICKLY (Mont Blanc).—The house dry, temperature rising from 65° to 70° in the hottest part of the day. The dry atmosphere may be partly the cause. Your frequent ammonia and liquid manure waterings at this season, another cause. A little peat would also be an advantage in the soil in winter, and for winter-blooming the plants should not be more than twelve or eighteen months from the cutting. Your temperature at night should not be below 48°; 5° higher will be better. Mr. Fish detailed how he kept old plants in winter, some time ago, but such rough treatment left the plants like skeletons. A present sacrifice was submitted to produce a future fine effect. From what you state, if you have not young plants, we would lose no time in fresh potting the plant, getting rid of the sour soddened soil, saving all the roots you can, and making rough sandy peat and charcoal a component of your compost.

ACHIMENES (Ibid.).—The leaves sent are just as we should expect to find them. They will always be so at this season, unless, indeed, you have started them late for winter blooming. The appearance indicates either that the season of growth has approached its termination, or that you have scalded them with the sun while the foliage was wet. In either case, your best plan now is to keep the plants in an open, airy place, withhold water gradually, and then turn the pot on its broadside, anywhere, so that the temperature does not fall below 45°. When you want to set the plant growing again, in the new year, turn out the pot, break the soil, and separate and plant the tubers afresh.

GREENHOUSE AND VINERY (Carrig Cathol.).—We do not say anything about the "third time breaking the charm," but beg to assure you that no previous two separate inquiries have come in our way, as, sooner or later, every correspondent and inquiry receives attention. We think that, in the present case, your own judgment and views of economy must decide. You have already got your 7½-foot-long sashes; two of which, joined together, is to form your fixed sloping-roof of fifteen feet. But, as this will not enclose enough of width to suit you, you propose having a glass-roof at the back, so as to widen the house some three feet more, and ask us how long we would recommend such sashes to be. Now, if we possessed the purse-strings, we should have both sides alike—in other words—a span-roof; and then we would have an opaque part in the centre, where all the airing at top would be given. But, waiving the span, and fixing on the short hip, we would recommend the sashes to be about four feet in length, more if you liked it; and now come the other difficulties. You are told that this hipped-roof would make the house colder. Undoubtedly so, every inch of glass will radiate so much heat. You are recommended, therefore, not to discard these short sashes, but to place them at the top of the others, movable, so as to give air thereby, making thus a sloping-roof of 19 or 20 feet; but we do not see how this would greatly economise your heat, farther than having more wall as a retaining power. Were vines, however, your chief object, this, in the circumstances and the size of your sashes, would be the recommendation we would, without hesitation, give. If plants are your chief object, then, if you cannot have a span, then have the hipped, and have it movable, so as you can have abundance of air, unless, indeed, you have other means of giving air in the back wall. This will also be essential in the front wall or front sashes. As economising heat is an object, your house will thus be less exposed to the wind than if the glass had all been of one slope. It is quite true, that you will economise heat and gain width by having a hipped-roof of slate or other opaque substance; but if you put plants in your house, then this, under the opaque-roof, would be of little use, unless as a pathway. If plants are your chief object, would it not be best to compromise the whole matter, by having a hipped-roof, and covers made of wood, asphalt, or tarpaulin, to go over them in all cold weather, and even over part of the roof in front likewise. If laths are placed for such covers to run upon, neither paint nor wood would be injured; and in all places at a distance from the coal-pit, the saving would soon pay for the covers, while the plants within would flourish more.

DISEASED BULLFINCH.—"Your correspondent's (F. L.'s) bullfinch I fear is past a remedy. If it be asthma, linseed is recommended to be given with its food, and soft bread and milk. The linseed is supposed to be demulcent; liquorice-root steeped in water for its drink. But I believe nothing will relieve it. I suspect it is infested with a small parasitic worm, which attaches itself to the wind-pipe or tubes of the lungs by means of its sucker-like mouth, leaving its body hanging loosely or undulating, as it were, in the tubes; this produces excessive irritation, ulceration, wasting of the body, atrophy, and death. The only remedy for this, is shutting the bird in a close box, and subjecting it to tobacco smoke, when, it is said, the worm will be detached from its hold and thrown off; but I must tell you most of the patients die from the treatment, so that it is questionable whether the remedy is not as bad as the disease, as they die from both." WILLIAM RAYNER.

WHITE CINERARIA (W. H. L.).—If it does not produce better blooms in its natural season it is worthless. The petals were thin, notched, and starry, in the bloom you sent.

RABBITS (Philo-Leporidae).—We do not know of any separate work relating to them. We should be very much obliged by any of our readers sending us the results of their experience in the breeding and rearing of these beautiful animals.

HOUSE SEWAGE FOR DAHLIAS (A New Subscriber).—This, mixed with earth, and applied to the soil in moderate quantities, will be beneficial.

POULTRY HOUSE (N. R.).—We shall have a drawing of one published before the year closes, and will give the dimensions, &c.

WHAT IS HEMONY? (Hester S.).—Milton in his *Comus* has these lines:—

"Amongst the rest, a small unsightly root,
But of divine effect, he cull'd me out.
The leaf was darkish, and had prickles on it,
But in another country, as he said,
Bore a bright golden flower, but not in this soil:
—More medicinal is it than that Moly,
That Hermes once to wise Ulysses gave:
Unknown and light esteemed, and the dull swain
Treads on it daily with his clouted shoon:
He called it *Hemony*, and gave it me,
And bade me keep it as of sovereign use
'Gainst all enchantments."

Some think that Milton merely adopted the name from Ovid's *Metamorphoses*, lib. viii., lines 264-5, where the poet speaks of a plant *Hemonia*, its roots, and other parts. Others think with Coleridge in his *Stateman's Manual*, that Milton intended to allegorise the sacramental wine; deriving the name from *aima*, blood, and *ainos*, wine.

CROSS-BRED FOWLS (A Rooster).—It is possible, but not probable, that superior birds may be produced by crossing the varieties, but the pullets so raised must be coupled, we think, with a cock of the same variety as their hen-parent. Your failure in producing superior specimens of a pure breed arose, probably, from your breeding in-and-in—that is, the cock and hens were from the same brood; and then again, to insure further degeneracy, the old cock was coupled with the pullets, his own progeny. The first rule in all stock-breeding is—*Never couple relatives together.*

REMOVING SMELL OF HOUSE SEWAGE (A House Agent).—Mixing gypsum (sulphate of lime), with it as you propose, will partially effect your purpose, which is called "deodorizing;" but a more effective addition would be peat-charcoal. We should recommend you to add some gypsum also.

ADVICE (Grumbler).—We believe that almost every one of your suggestions have been attended to, which is the best evidence that we should not have quarrelled with you, even if we had not anticipated your wishes.

SPANISH AND OTHER POULTRY.—Semper Vigilans says.—"Let me just speak as to my own experience, this being my first year of the above breed. From nine eggs in April, I got seven chicks; nine in May, eight chicks; cut of both, fourteen now live, and one was killed by the mother of the other hatch; being a game hen, the cock setting up his feathers paid the piper. Wanting chiefly eggs, yet combining good fowls for table use, I was led to choose this breed from reading Richardson's work, and also seeing them so highly spoken of at the Birmingham and other shows. My step was at once to get eggs of the best breed then known; as such, half came from Mr. Hornby's stock, half Mr. Peck's, which I intend to cross, and at stated intervals procuring a good cock of fresh blood. It is my intention to see the show at Birmingham, to judge, from observation and opinions gathered, how my birds contrast. Now, in the first place, they are confined to a space eight yards by three yards, wired off, taking in the stable dunghill. My pullets have regularly began to lay in November, if not October, and are still laying; but my Spanish do not promise to lay before December. The cocks of May 3rd weigh 4½ lbs. to 5½ lbs.; pullets, 3½ lbs. Although never a day's sickness, they strike me as far short of what "Richardson" gives you to expect in size. Next: I have anxiously been looking for proof how to breed for table use; as yet, my own plan strikes me as best for such result. Along with the Spanish hen and cock for layers, I think of putting one Cochon and one Dorking hen, of the best breeds, and so allowing them to sit their own eggs for killing. All three being pronounced best, must surely result well. [Quite the contrary; the mixtures will be generally odious]. If, when parties write of weight, they would also give age, and when most suitable for table, the result might be more correctly attained. Should this opinion of quality not be settled before next autumn, the price of my birds shall not prevent me and my friends giving you our candid opinion."

ADVERTISEMENTS (Rector).—We are as anxious as you are to avoid having these bound up in the volume, but we are at the mercy of the advertisers in this respect.

MISTLETOE (B. R.).—To raise this on the tree you wish it to grow upon, cut *underneath* a branch, quite down to the wood, a tongue of bark in this form, **A**; raise up the point of the tongue, and squeeze into it the seeds from a ripe Mistletoe berry, and then let the tongue close down, but do not press it. The best time for this sowing is February.

GRAFTING CRAB STOCKS (Crab Stock).—It is not good practice to remove the stocks now which you propose grafting upon in the spring. Why not let them remain where they are, and remove them after they have been grafted? You may graft upon them any varieties you may prefer.

RHUBARB FORCING (A. B.).—Any of the varieties will do for this purpose, but the *Victoria* being the largest is preferable. Put a chimney-pot, with a piece of board upon its top, over an old-established plant, and whelm over the pot fermenting stable-dung, or leaves, two or three feet thick; or you may make a frame of laths three feet high over a whole row of Rhubarb, and heap the fermenting materials upon that. The time to commence forcing is December. There is no permanent mode of driving away worms from a lawn. Occasional watering with lime-water, and sprinkling with common salt, will keep them from coming near the surface.

PEARS (Verax).—There are three Louise Bonnes, viz., Louise Bonne, Louise Bonne d'Angers, and Louise Bonne of Jersey, all different. *Yellow Calceolarius* shall be attended to.

GREY-SPECKLED DORKINGS.—The Rev. R. E. Morres, Ashcott, Glastonbury, Somerset, will be glad to know where he can obtain these true, and at what price?

GREENHOUSE WITH WEST ASPECT (S. R. W.).—You may grow both vines and plants in this.

LONDON: Printed by HARRY WOOLDRIDGE, Winchester High-street, in the Parish of Saint Mary Kalender; and Published by WILLIAM SOMERVILLE ORR, at the Office, No. 2, Amen Corner, in the Parish of Christ Church, City of London.—November 11th, 1852.

WEEKLY CALENDAR.

M D	W D	NOVEMBER 18-24, 1852.	WEATHER NEAR LONDON IN 1851.				Sun Rises.	Sun Sets.	Moon R. & S.	Moon's Age.	Clock aft. Sun.	Day of Year.
			Barometer.	Thermo.	Wind.	Rain in In.						
18	Th	Widgeon arrives.	29.871—29.839	41—16	N.	—	26 a. 7	5 a. 4	11 2	☾	14 33	323
19	F	Helvella mitra seen.	29.840—29.644	37—25	S.W.	—	28	4	morn.	8	14 19	324
20	S	Waxen Chatterer seen.	30.062—29.861	43—24	N.	—	29	2	0 13	9	14 5	325
21	SUN	24 SUN. APT. TRINITY. PRS. R. born.	29.930—29.830	46—34	W.	—	31	1	1 21	10	13 49	326
22	M	Sun's declination, 20° 15' s.	30.149—29.998	45—25	N.	—	33	0	2 29	11	13 33	327
23	Tu		30.133—29.855	45—32	W.	18	34	111	3 35	12	13 17	328
24	W	Gray Wagtail comes.	29.493—29.452	46—23	N.W.	—	35	58	4 42	13	13 59	329

METEOROLOGY OF THE WEEK.—At Chiswick, from observations during the last twenty-five years, the average highest and lowest temperatures of these days are 49.2° and 36.2° respectively. The greatest heat, 59°, occurred on the 18th in 1844; and the lowest cold, 18°, on the 19th in 1841. During the period 83 days were fine, and on 92 rain fell.

LARGE-FLOWERED GRINDELIA.

(*Grindelia grandiflora*.)



THIS is a good addition to *Grindelia*, a well-known Mexican genus of Composite plants (Asteraceæ), with showy yellow flowers. It was discovered in Texas by Dr. Wright, whence he sent seeds of it to the Botanic Garden at Kew, where it was reared, and proved to be no more than a hardy biennial in our climate, reaching from three to five feet high, and blooming till very late in the autumn. There is another plant in this country, erroneously called *Cineraria tussilaginoïdes*, with large yellow flowers, the counterpart of those of this species. The genus was named by Willdenow, after a German botanist called Grindel. The species is well represented in the *Botanical Magazine*, t. 4628, where it is named and described by Sir W. Hooker.

It belongs to Syngenesia Superflua Class and Order of the Linnæan system. Each stem branches into three or four; each branch leafy, and bearing at its top an orange-coloured flower. Leaves alternate, stalkless, spear-head shaped, toothed at the base only; flowers very large; ray florets strap-shaped, with a tubular base; disc florets yellow, tubular, five-toothed.

B. J.

Propagation and Culture.—This is another addition to the long list of Mexican Composites which have appeared from time to time under cultivation, but which were no sooner on the stage than they disappeared again, for which three distinct causes may be assigned. The first is, that these yellow flowers, like a single yellow *Chrysanthemum*, are considered too common-looking since the rage for herba-ceous plants has subsided. Secondly, that seeds are not ripened with us when these bull-eyed plants flower late in the season, as is the case with this *Grindelia grandiflora*, which was in bloom at Kew till the frost of November, 1851, put a stop to them; and, thirdly, that their roots are not sufficiently hardy for our winters.

There are none of the *Grindelias* more deserving of cultivation than this, because it flowers so late in the season. By far the easiest and surest way to increase and keep it would be to make cuttings of it every season in July, under a hand-glass, out-of-doors; and to give the after-culture exactly as for cuttings and young stock of *Penstemon gentianoides*. In the spring, planting six or seven plants in a patch at the back of the mixed border. Any good garden soil will suit it very well, if it is well worked, and is not robbed by the roots of stronger plants.

We are not yet half alive to the benefit that we might derive from hardy subjects in this extensive order, by turning them into double varieties, of which they are, by nature, more capable than any other race. Some one will yet make a fortune and a name out of the *Michaelmas Daisy*, which we almost despise. The *Cineraria* itself will not be of more varied or gay tints in-doors in the spring than the common *Asters* will be then right out in the open air. This *Grindelia* would be an excellent plant to begin experiments upon. The fact that we must keep it in stock from cuttings is as likely as not to change the nature of it, so far as to cause it to throw off a double-flowering seedling some day or other, for this very reason, that we always make a better bed for a plant that requires so much care than for another, even with a better flower that will take care of itself. Another reason is that a plant from a cutting has not so strong a constitution for the first year or two as a seedling plant of the same sort; and we have great reason to believe, that by reducing the constitutional vigour of a plant, and at the same time giving it a higher degree of culture, is as likely to cause its flowers to turn double. That is, if we can sow seeds from it, if ever so few. No one is now so ignorant as to believe that the art of man can ever turn a plant double otherwise than by seedlings.

D. BEATON.

At page 264 of our last volume, we brought down our tracing of Poultry literature to the time of Gervas Markham, in 1631, and we may pass from thence over the whole of the eighteenth century without finding one author whose works deserve quoting upon the subject. We have referred to Mortimer's "Whole Art of Hus-

bandry," published in 1708, and to many others, and find that where they are prolix, they borrow from the ancients, and where they write from their own experience they are brief and unsatisfactory. Thus, Mortimer says, "As for cocks and hens, I shall not enter into a description of the several sorts of them, only advising

you to choose those that are the best breeders and the best layers;" and similar off-hand, half-contemptuous sentences might be quoted from other writers of that century, showing how little was the value placed upon this kind of stock, and that no attention was bestowed upon its improvement.

The first work that we know of shewing the dawn of better attention to this description of farming stock, is Mr. Bonington Mowbray's *Practical Treatise on Breeding, Rearing, and Fattening, all kinds of Domestic Poultry*. This first appeared in 1816. Between which date and the present, we believe it has passed through nine editions; at all events, the eighth, dated 1842, is now before us. The author understood his subject, wrote from experience, and gives us this first evidence of care and system that we have met with in relation to this branch of rural affairs. He says—

"I have, throughout my life, been a breeder and keeper, and also an amateur of domestic poultry, pigeons, and rabbits; at some periods, upon rather a considerable scale; and have, for many years together, kept a register of the results. I have further done that which, I believe, no other man has taken the pains to do—kept a regular stud book for those breeders, scarcely one of which was so poor as to be without a name; and Regulus, Samson, Flea-catcher, Selima, Moreau, Isaac, and Tom Paine, shine with peculiar lustre on my poultry and pigeon list; whilst Corney Buttercup, Adam, Beelzebub, Lucifer, Carolina, Heecuba, make a figure equally splendid and equally useful, among the rabbits. I think *Montaigne* says somewhere, that if a man would sit and describe that which he has known practically, upon almost any subject, he could scarcely fail of being useful. Just so far my ambition extends. Nor is the world entirely without need of advice on this subject, notwithstanding its antiquity, and the multitude of counsellors."

Every page of his volume testifies that he wrote down only the results of experience, and from these, as from other authors, we shall place before our readers a specimen. In speaking of raising early broods, he says:—

"The number of hens to one cock, four to six, the latter being the extreme number, with a view of making the utmost advantage. Ten and even twelve hens have been formerly allowed to one cock, but the produce of eggs and chickens under such an arrangement will seldom equal that to be obtained from the smaller number of hens. Every one is aware that the spring is the best season to commence breeding with poultry, and, in truth, it scarcely matters how early, presupposing the best food, accommodation, and attendance, under which, hens may be permitted to sit in January; but the attempt to rear winter chickens in this climate, even in a carpeted room and with a constant fire, would, in all probability, be found abortive. I have repeatedly made the experiment with some scores, without being able to preserve an individual through the winter, and nearly the same has resulted with respect to pigs, on a damp clayey or marshy soil. This I request should be understood with some grains of allowance in respect to the soils on which my stock of both kinds was reared, in three counties. They were clayey, wet, and benumbing, and my neighbours were in a similar predicament with myself. It is a mere statement of facts. I have referred in the sequel to those dry soils, better adapted to breeding of poultry, as they are also to breeding and keeping of sheep. I give merely my own actual experience, without doubting that many breeders more fortunately situated have succeeded with winter stock, though, in the best situations, winter may bring with it considerable risk. A record, however, of the experimented fact may remain, as a caution to breeders upon unfavourable soils. The following is a remarkable instance of attention and success in winter breeding.

"The late Mrs. Adams, of Ditchford Farm, near Shipton-on-Stour, in Worcestershire, for many years devoted her

time and attention to the breeding and rearing of winter chickens and spring ducklings, with which she constantly attended Campden and Shipton markets, where her poultry was sought by the neighbouring gentry with avidity, and generally fetched good prices; the superiority of this good woman's poultry was proverbial: as a breeder and fancier she stood pre-eminent; her chickens were always ready for the table by New Year's day, and her ducks were earlier in the market than those of any other person in that neighbourhood. This is given, not as a novelty, but as an example of merit and successful perseverance. In the vicinity of most cities and large towns, chicks and ducklings are reared in the autumn for the Christmas market. The business is done by the aid of artificial heat, by stoving, and with covered floors."

Next appeared, in 1845, *Poultry; their breeding, rearing, diseases, and general management*, by Walter B. Dickson. This is far superior, as a compilation, to any other work we know on the subject. There are gathered together, and arranged in its pages, all the information that is scattered through our county Agricultural Surveys, the French works of M. M. Réaumur and Parmentier, &c.; and he includes in his extracts many from Markham, and, indeed, all his English predecessors who wrote of the same subject. The following is a favourable specimen of his writing—

"THE COLOURS OF FOWLS.—The varieties in the sizes, forms, and colours of fowls, are sufficiently striking to attract the notice of the most indifferent observer; while, to those who can find subject of reflection in every production of nature, they may be made an ample source of interesting remark, as well as of amusing experiment. 'If people,' says M. Réaumur, 'are affected with the kind of pleasure so transitory to the most enthusiastic florists, who procure it but for a few days by a world of care and toil continued through a whole year—if they are affected by the variety and fine combination of colours in their favourite flowers, the poultry-yard, when well managed, may be made to offer them endless pleasures of the same description.'

"The greater number of cocks, even those of the commonest breeds, when exposed to the play of the sun's rays, exhibit the brightest colours, in extraordinary beauty, and varied mixture; and even the hens, if the breeds have been select, are often no less worthy of admiration. Some, for instance, have spots distributed with great regularity, and so brightly white as to look silvery; others are termed golden, because they are spotted or speckled with a fine golden orange colour; while the more common colours are varied in a manner almost endless; and, upon the whole, domestic fowls offer a multitude of colours, the several shades of which would be found with difficulty, if they were sought for amongst the birds of the woods or the waters.

"Another peculiarity in the colour of fowls is, that they frequently change in a very surprising manner, from the time when the chicks cast their down to the annual moult of the full-grown fowls. It is, no doubt, the regular process, at least after the second and third moults, for the colours to continue much the same. I have, at present, a hen of the Spanish breed, which has been of a uniform black for two successive moults, but has now her neck, wings, and tail feathers tipped with pure white. I have another which was all over of a silver grey, but has now her head and neck coal black, with a ring of fine white at the base of the neck, while the rest of the body is finely speckled with black and snow white. It is remarkable also, that this change took place in a few weeks, without any obvious moult, so as to cause her to appear anywhere bare of feathers.

"We are told by M. Réaumur, that one of his hens which his poultry-woman distinguished from the rest by a crooked claw, when her coat began to be taken notice of, had feathers of a ruddy colour mixed with the brown so common among dunghill fowls. A year afterwards, this hen was observed to become almost black, with here and there some large white spots. After the second moulting, black was the predominant colour on every part of the body; but strange to tell, upon the succeeding moult, white was the pre-

dominant colour, and only a few black patches about the size of a crown-piece could be observed. Upon the succeeding moult, all the black spots disappeared, and the hen became uniformly of a pure white like that of a swan. As she was at this time old for a fowl, that is, not less than ten years, it might be thought that old age, which whitens the human hair, likewise whitens the feathers of certain birds; but, in that case, M. Réaumur says, the transition from the ruddy to the white ought not to have been made, as it really was, through the black; and he was of opinion, as the hen was still vigorous and healthy, that she might again change her colour, if she lived, to brown or black.

"M. Réaumur makes some interesting remarks on a cock which he observed with more attention than the hen, so as to establish proofs, that the white colours of the feathers were not, at least in that instance, caused by age. The owner of the cock was struck, the first time he moulted, with the singular change in his colour; and for five successive moults, there was always a considerable change of colour. In his first year, he had some of the ruddy brown, mixed with white, so common in dunghill cocks; in the second, he was all over ruddy brown, or rather red, without any white; in the third, he became uniformly black; in the fourth, uniformly white; and in the fifth, when he was presented by the prior of Bury to M. Réaumur as a curiosity, he had white feathers mixed with a good deal of ruddy colour and brown, bordering upon chestnut, his neck, back, wings, and belly, being ruddy; and even where there were white feathers, they were mingled with ruddy ones. During the summer vacation at Paris, M. Réaumur was two months without seeing the cock; but in this period he became so changed as not to be recognisable, his feathers having become all over of the finest white. The following year he had partly white feathers, but the greater portion was ruddy, or rather of a fair red. Here, then, was a transition from white to a light brown, indicating that the whiteness of his feathers was not owing to the number of his years.

"It has been remarked by several scientific observers, that hen birds of various species, but more particularly hen pheasants, put on, under certain circumstances, the plumage of the male. The celebrated physiologist, Mr. John Hunter, in his work on the "Animal Economy," is of opinion that 'this change of character takes place at an advanced age of the animal's life, and does not grow up with it from the beginning.' Mr. Butler expresses a similar opinion still more strongly, namely, that 'all hen pheasants, as well as common fowls, would assume the plumage of the cock, to a certain degree, if they were kept to a certain age.'—(*Mem. Werner. Soc.* vol. iii.) Though this, however, to some extent may be true, the reasons, or rather the accompanying circumstances and changes of constitution, were first pointed out, it is believed, by Mr. Yarrell, who seems to have determined that the change of colour depends on disease, or removal of the ovarium of the fowl. Among seven hen pheasants, whose plumage more or less resembled that of the male, he found the organ in question diseased, with some variation as to extent, and the progress of change observable in the plumage bore a corresponding analogy. At the commencement of this internal disease, the plumage does not seem to be affected, for 'hen pheasants in confinement, and female of the common fowl in the poultry-yard, had been known to have ceased producing eggs two years before any change was observed in their plumage.'

We have yet three or four modern works to notice, and must, therefore, defer our concluding remarks to a future week.

COVENT GARDEN.

It is astonishing how many subjects are suggested to the mind during our observations on the produce offered for sale in Covent Garden Market, and in the preparation of these reports; subjects both of historical and economic, as well as financial interest. There are many articles produced here which recall the names and experience of names honoured in some department of

horticulture, and others which suggest systems by which we may improve and increase our internal resources. Among these last, we have often thought that a great deal might be done by an extensive and judicious planting of the best varieties of fruits. The importation of Apples, Pears, and Plums is every year becoming greater; and, surely, fruit of our own growth, produced in market with all the freshness of recent gathering, must be far more acceptable than that which has been stowed, and heated, and mouldy, and, in many instances, gathered before it is nearly ripe. There was a great outcry, some years ago, when the duty was taken off foreign fruit. Our growers, like a boy flinching under a threatened blow, hung down their hands, at what they thought was an approaching calamity; and, instead of planting more extensively, and withstanding the approach of the foreigner, they cried out for help, and in the midst of their despair quite forgot to help themselves. Within the last few years a re-action has taken place. When the foreign fruit was admitted, prices fell, and the mechanic who had an apple-dumpling only once a week before, had it three times then: the demand and consumption increased; the home-grower had not enough to supply it, and the foreigner, of course, reaped as great an advantage as he did. Our growers began to find this out, and they set to planting more extensively. Still, however, the demand increases; the prosperity of the country, and the increasing comforts and luxuries of the working classes cry, "give, give." Railways bring town to country and country to town, and year after year we find consumption on the increase. Now, the first object to be kept in view in planting new plantations is the varieties of the fruits. The sorts in general cultivation twenty or thirty years ago will not do now; and it is our intention, next week, to allude more particularly to the varieties which we consider best adapted for this purpose, and which will be most remunerative to the grower. Meanwhile, we shall proceed as usual to record the state of the market for the past week.

FRUIT.—The supply of APPLES during the week has been rather short. Many of the growers are holding back in expectation that the supply will be short. There is no doubt that the crop this year is much shorter than last, and prices will be higher, but we question if it will be judicious on the part of holders to overstand the market while they can realise a fair price. The consequence of holding back will be, a considerable rise, and also a large importation, and then comes the usual reaction—a fall. And it ought, also, to be borne in mind, that there are many feeders to London now; fruit is brought from districts in England in the present day which either consumed or destroyed the crop in the olden time for want of an outlet; and a high price will pay to send from great distances. The prices which have been made during the week are, for cooking Apples, 3s. 6d. to 6s. per bushel, consisting of *Yorkshire Greenings*, *Kentish Broadends*, *Catsheads*, *Beauty of Kent*, and *Flower of Kent*. Dessert Apples are making 4s. to 8s., and are *Ribstons*, *Blenheim Pippins*, *Fearn's*

Pippins, Golden Pippins, and Braddick's Nonpareils. PEARS of the common kinds are not so plentiful; the early orchard varieties are getting over, and what come now are chiefly the finer varieties, such as have been planted of late years. The most choice are *Duchesse d'Angoulême, Passe Colmar, Glout Morceau,* and we have observed a few parcels of *Beurré de Rance.* These are making as much as 3s. and 4s. per dozen. Some very fine *Duchesse d'Angoulêmes* make as much as 6s. per dozen. What few there are of the more common kinds make 5s. to 7s. the half-sieve. GRAPES are plentiful; *Black Hamburgs* realise from 1s. 6d. to 5s. per pound, and *Muscat of Alexandria,* 6s. MELONS are plentiful, at 2s. 6d. and 6s. per pound. FILBERTS, 60s. to 65s. per cwt., or retail at 10d. and 1s. per pound. ORANGES are now beginning to come more plentifully; they are, however, rather of a greenish tinge, and make from 6s. to 12s. per hundred.

VEGETABLES.—There is no alteration in the supply of vegetables, and the prices in consequence continue much the same. CABBAGES, 6d. to 1s. per dozen. BRUSSELS SPROUTS, 1s. 6d. to 2s. per half-sieve. CAULIFLOWERS, 1s. 6d. to 2s. 6d. per dozen. GREENS, 1s. to 2s. per dozen bunches. TURNIPS, 1s. to 1s. 9d. per dozen. CARROTS, 2s. 6d. to 4s. per dozen. ONIONS, 2d. to 4d. per bunch. LEEKS, 1d. to 2d. per bunch. CELERY, 9d. to 1s. 3d. per bundle. SCARLET RUNNERS, 2s. to 2s. 6d. per half-sieve. ENDIVE, 1s. to 1s. 6d. per score. MUSHROOMS, 9d. to 1s. 3d. per pottle.

PLANTS AND FLOWERS.—The usual sorts of EVERGREENS in pots are offered, and seem to meet with a ready demand. Plants in pots consist of *Chrysanthemums* of all kinds, *Heaths, Cinerarias, Chinese Primroses,* double and single, *Mignonette,* and *Ficus elastica,* or *Indian-rubber Tree.* The CUT FLOWERS are abundant, and consist of *Scarlet Anemones, Roses, Trachelium cœruleum, Pinks, Heliotropes, Scarlet Geraniums, Stocks, Camellias, Cereus speciosus, Double Chinese Primroses, Jasminum grandiflorum, Gardenia radicans,* and last, though not least, *Orange Flowers!* H.

GOSSIP.

No fact is more certain—and this certainty gives us great pleasure—than that even farmers are becoming more awakened to the importance of *Poultry* as a portion of their stock. Lord Ducie was a considerable buyer of Shanghai fowls at Mr. Sturgeon's sale; other practical agriculturists are following the example of Mr. Moody, Mr. Sturgeon, and Mr. Punchard; and we have no doubt but that within five years the breed of *Poultry* will be so improved, as to make both farmers and poulterers smile over the remembrance of the weedy mongrels prevalent at the present time. The desire to obtain first-rate birds is not confined to one variety; and, as a proof of this, we may state, that a correspondent informs us, that he knows Captain Hornby refused to take thirty-five guineas for three Spanish fowls which he exhibited at Cheltenham. The same

correspondent, writing from near Liverpool, adds this account of another convulsion—

"It may interest you to know, that after a very hot day and evening (very oppressive) we were all roused by a sharpish earthquake at twenty-five minutes past four this morning (Nov. 9th). From the shaking of the windows when I awoke, my impression was that thieves were breaking through the windows. I jumped up, and struck a light, when my wife showed me the bed and curtains heaving and shaking, and the things on the washing-stand were clattering. I think it lasted near two minutes, with a disagreeable rumbling noise. It was felt at Roby, Seaforth, &c.; but a party of keepers, who were out about four miles from here, did not feel it. It was sharper than most I have felt abroad."

Privation and want bring with them so much of suffering, not merely personal but relative, that the heart softens, and the hand is stretched forth to save from them those accustomed even in their infancy to hardships and deprivations. Still more impressive, still more exciting of every benevolent feeling, comes upon us the information that the great in learning and in virtue are similarly pressed down and benumbed by poverty, and such information has just come to us concerning the celebrated German naturalist *M. Nees Von Essenbeck.* Our contemporary, the *Gardener's Journal,* says that the professor,

"On account of his liberal opinions incautiously expressed during the revolutions of 1848 and 1849, was deprived of his professorship, and is now living in a low suburb of Breslau, in a place called a room, over a cow-shed, and without companion or attendant. He is said to be in his 76th year, and literally starving from want. It is further stated that, some time ago, his library was sold to pay some debts; and his dried plants, which are now his only property, and which, although in some branches they are unequalled, he has nevertheless been unable to dispose of.

"It is a melancholy fact, which we would look past and beyond if we durst, but the fact is patent to all, that science does, with rare exceptions, exact this severe penalty from her true and genuine disciples, as a test of their true devotion. Poverty, indeed, often deep and distressing, would seem to be all but an unalterable condition imposed upon those who unreservedly follow the leadings of science.

"It may, perhaps, be urged that Von Essenbeck suffers not for his devotion to science, but for his meddling with politics. Let us even grant that it was quite competent for the government of his country to supersede him in the Chair of Botany, which he had so long and so ably filled, surely his grey hairs and the invaluable labours of his life ought to have secured him, if not a reasonable competence in his retirement, at least sufficient to make the remainder of his life bearable. Instead of this, however, the man who had so long occupied a leading position among the *savants* of the continent—if we are to believe our authority—'is literally starving from want!'"

The fate of *William Gardiner,* whose death we noticed some months since, leaving one orphan boy, is a painful testimony that poverty and science are too often mated. We mention this, however, more especially for the purpose of making known that Mr. G. Lawson, Curator to the Botanical Society, and Lecturer on Botany at Edinburgh, having undertaken to prepare a Biographical Sketch of *William Gardiner,* with selections from his unpublished papers and letters, and notices of those other self-taught naturalists in humble life, who were his local contemporaries, will be obliged by parties in possession of original MSS. and letters bearing upon the subject, favouring him with the use of the same. It is intended to add, in an Appendix (from unpublished

MSS.), Contributions to the Fauna of Forfarshire; also, additions to the Flora of the County, embracing those Plants not recorded in Mr. Gardiner's "Flora" (now out of print), as well as additional localities, &c., for the rarer species. In this department assistance is invited from local naturalists, whose contributions of facts will be duly acknowledged in the work. Communications may be addressed to Mr. Lawson, 7, Hill Square, Edinburgh.

It is too usual to turn from *Rabbits* as profitless animals, and to associate them with the remembrance of various unsavoury smells. Both these arise from mismanagement, for we know of instances where they were most profitably kept; the yard in which they were was perfectly unoffending, and their manure was the best fertiliser of the adjoining garden. That the breeding of rabbits might be made still more remunerative we have no doubt, for the consumption of them is very large, and the importation from Ostend so extensive, that a deputation from the poultry trade recently stated to our government, that the traffic in rabbits from that port finds employment for from 180,000 to 200,000 persons.

Very recently has been published two very unpretending volumes by Andrew Hamilton, Esq., entitled "*Sixteen Months in the Danish Isles.*" We shall only give from them two short quotations, adding the assurance to our readers, that they will find the work one of the most amusing that has been published this year:—

"From the cemetery, the road goes at once into the country. 'Tis a pleasing change, partly, perhaps, because not a sudden one, to come from the burying-ground to the fields where they are sowing the grain for autumn's harvest. There are plenty of nice land-like farms in the immediate neighbourhood of the metropolis; large comfortable establishments, with apparatus fit for laying in provision of all kinds for the longest winter at a hundred leagues from any town, yet they have the chief town at the very door. And now husbandmen marched o'er the furrows, and scattered their precious seed, in the dull bleak afternoon of a cold spring day, when it needed some faith to believe that the season of budding and blossoming was at hand. But in the trees and about the grass there was now a tendency to burst forth and shoot, that gave notice the time of earth's verdure was about to return. Spring is the time when the sower soweth his seed; it happens also to be the time when most human bodies are laid in earth. The fates of the two are wonderfully similar. As I leaned over the paling and looked at the husbandman's field, I knew that, in a few months, the seeds he planted there would have burst forth, renewed and multiplied, and that the scene, by the blessing of Heaven, would be one of redundant life and beauty. And when I turned my head towards the dead wall I had lately passed, and thought of the more dead enclosure within, I knew that there also, one day, would be a similar scene of revivification, even 'there,' as Bishop Taylor saith, 'where the field of God is sown with the seeds of the resurrection.'"

"Harvest was all past save the fruit harvest. This year there happened to be an unusual abundance of apples and pears, but the quality was inferior. The season had, on the whole, not been genial enough to ripen the fruit; but the spring had been peculiarly favourable to its formation, and the quantity was quite prodigious. Owing to these two circumstances, many people did not think it worth while to gather their fruit at all; they took as much as they might be likely to want, and allowed the rest to rot. In many of the gardens and orchards of our neighbours, we trod on walks covered with fallen apples,—a not very desirable or dry kind of gravel. The plenty was so enormous, I did not

wonder at people becoming hopeless of ever housing it, or using it if they did. And it appeared that there was no market for so much fruit in Copenhagen.

"There was no such scene in the garden-walks of my host, who considered it as a despising of God's gifts to take no pains to reap the kindly fruits of the earth. Whatever might eventually be their fate, they were meantime to be husbanded.

"For many days, nay, for weeks, there was no cessation in the plucking, bearing in-doors, and stowing away of apples. The trees in the garden were, many of them, inhabited by one or two human beings, busy from morning to night, filling large baskets. Two men did nothing but carry the fruit to the house. Many times did I marvel at that constant carrying. Come down stairs when one would, and look through the window whatever time it chanced to occur to one, it was impossible to fail seeing the same two men marching from the garden-gate across the court-yard to a door on the other side, and bearing between them the same large hamper piled high with apples. It was as if the men, on reaching their destination, were transported back to go over the same ground again. I used to think it must be a pastime the mansion owners got up for their guest's amusement, or that it took place by enchantment. I remembered the American superstition of Jumbieback,—the evil spirit who assumed the form of a vast plain or prairie. When travellers essayed to cross the seeming muirland, he allowed them to get on very well during the day, but at night, when they stuck up their tents, he would give a quiet hitch, and transport them back to the self-same spot they had left in the morning, so that they might traverse the treacherous prairie till the day of their death, and never advance one step. I was ready to think my two apple-bearers had got upon Jumbieback.

"Up, above the highest floor of the mansion, it seemed there was a series of attics which were used as store-rooms. There, one of the ladies presided for many days over the disposition of the fruit, until she announced that she abhorred even the smell of apples.

"There was proportionally a like plenty of pears which were the only fruit we thought worthy of being eaten. In the forenoon and in the evening, we used to consume them as heartily as we could; but we made little progress. Each day saw large loads afresh brought in; so we fell upon a clever plan. In the morning, when we took our walks, it was resolved to bear a moderate-sized basket filled with ripe pears for distribution among such of our humbler neighbours as we might meet, or whose cottages we might pass. I carried the basket, but when a cottager hove in sight, I delivered it to one of the ladies, knowing that she could dispense its contents more wisely than I, and that they would be more welcome from her hand. In the course of our round, of whatever length it might be, we always contrived to empty our basket. The attention on the part of the gracious Misses was evidently very well received by their dependents. The first morning of this arrangement, we met, not far from the gates, a large-built peasant girl. "Will you have some pears?" quoth one of the ladies, taking the basket from me, and emptying a good share of its contents into the apron that was at once held out to receive them. The girl spake not a word; but when she had bundled up her apron again about the fruit, with a somewhat theatrical air, as if her gratitude was too great for language, she seized the lady by the arm with her large fist, so that I thought she was going to put Miss's hand into her mouth; but it turned out she was only going to imprint a kiss on it, after which she went on her way.

"One Sunday, when we drove across to afternoon service at the parish church, owing to some error of the clocks, it turned out we had come nearly an hour too early. The clergyman had not yet arrived from his annexed church, at which he had been performing morning service. Coachman was bid to put up the horses, while the Major's asked me whether I would accompany her and her family to call upon the pastor's wife; I acceded.

"In stepping through the garden, I was made aware of the peculiarity in the good lady we were going to see, that, in spite of apparent perfect prosperity, and the absence of all outward calamity, she nevertheless found the world go evermore grievously against her, and her lot full of crooks,

of which she was apt to complain bitterly to all who came within ear-shot. Sometimes she was in such a sea of troubles, that she would hardly admit a visitor.

"We were, however, admitted.

"How do you do, Madame ———?"

"Oh! very middling! Will you sit down, Majoress?" (Here the foreigner was introduced, and made sadly welcome.) "I have just been in Copenhagen; returned on Friday. I ought to have staid longer for my health, for I have been suffering dreadfully from rheumatism; but the weather became so cold after I had been away two days, and as I had left no word here for lighting the stoves, I knew—" (here she mentioned her husband), "must be sitting in the cold, for they could not get the stoves heated without me, and I was obliged to come back to see it done. I was so vexed when I thought of his sitting without fire; I assure you when I thought of him sitting in a cold room, I grew so angry—I was so enraged—I could have—I don't know what I could have done."

"Here the good woman wrought herself into a frenzy, and rolled about on her chair, while we thought she might have spared herself much of the suffering by allowing the servant (or her husband) control enough over domestic matters even to light a stove on personal responsibility. But the pastoress did not suffer any one to rule or even advise in the house,—certainly not her goodman.

"We tried to lead her from the painful theme of the stove, and talked, of course, of the weather, as a gentle change, and other cognate things.

"It has been an excellent harvest," said some one; "there is a remarkable plenty of fruit."

"Fruit!" cried Madame ———; "oh, such an unheard-of quantity of fruit! Did you ever know such a plague? I never saw anything like it. I am sure, before I went to Copenhagen, I did nothing for days together but get the apples and pears taken into the house and put up in the attics; I was so sick of them! And while I was away the pears all rotted, and when I came back the juice had run down through the seams of the floor, and stained all the roof of the room below, and raised such a smell! We have three great pear-trees in the garden, and they bore such a quantity this year. I wish they were cut down;—I wish they were pulled up by the roots. Those wretched pears have spoiled all the ceiling of my room; I wish I had never seen one of them! And all when I was away from home!"

The following is a list of the *Horticultural and Poultry Shows* of which we are at present aware. We shall be obliged by any of our readers sending us additions to the list, and giving the address of the Secretaries.

HORTICULTURAL SHOWS.

BURY ST. EDMUNDS, Nov. 26 (Chrysanthemums). (Sec. G. P. Clay, Esq.)

CALEDONIAN (Inverleith Row), Edinburgh, Dec. 2.

HAMPSHIRE, Nov. 23 (Winchester). (Sec. Rev. F. Wickham, Winchester.)

LONDON FLORICULTURAL (Exeter Hall, Strand), Nov. 23, Dec. 14.

NORTH LONDON, Nov. 23, Chrysanthemum.

SOUTH LONDON (ROYAL), Dec. 9, 16.

POULTRY SHOWS.

BIRMINGHAM AND MIDLAND COUNTIES, 14th, 15th, 16th, and 17th December.

BRISTOL AGRICULTURAL, December 7th, 8th, and 9th. (Sec. James Marmont.)

CORNWALL (PENZANCE), January 10th, and 11th. (Secs. Rev. W. W. Wingfield, Gulval Vicarage, and E. H. Rodd, Esq.)

DORCHESTER, Nov. 24th. (Sec. G. J. Andrews, Esq., Dorchester.)

HITCHIN, Nov. 20th, 22nd, and 23rd. (Sec. S. Goodwin.)

HONIFON, January 12th. (Sec. H. K. Venn.)

WINCHESTER, December 1st. (Secs. G. W. Johnson and J. Colson.)

† For seedlings only.

PINE-CULTURE.

(Continued from page 59.)

It will now be necessary to pursue the subject of after-culture; we will then, if time and space permit, recapitulate the chief features. Before offering any comment of our own, it will be well to take a leaf out of Mr. Hamilton's book, and we may at once turn to page 31 of his truly practical work. He says, as to planting-out Pines: "On February 26, 1828, I planted forty-eight pine plants in the tan-bed, all of which, except one, fruited the same year. The process which I adopted was as follows:—The pit in which they were grown was twenty-seven feet long by ten feet wide inside; two feet of which were occupied by the flues and cavities, which left a width of eight feet for the tan-bed. After all the plants were taken out of the bed, the old tan was levelled, well trodden down, and smoothed with the rake; the whole bed was then covered with fresh tan to the depth of ten inches, the plants were immediately turned out of their pots, with *their balls as entire as possible*, and planted in the bed; they were then *beaten tightly* about the ball, and covered to the depth of one inch only. It will be necessary here to observe, that if the ball, with the roots, be covered too deep, *they will be in danger* of being *burned*. The tan used for this mode of culture must be from British bark, as it undergoes a slower fermentation than foreign tan; and I have always found that as it decays it is rendered less fit for supplying the plants with food. I have tried planting in old decayed tan, but the plants made very little progress; the fruit, also, was of inferior size. Foreign tan is objectionable, as it soon decays. I have been informed that it is mixed with the bark of some of the pine trees; if so, the resinous matter contained in such trees may be injurious to the roots of plants. I am of that opinion; for I have *never found foreign tan answer* for the above system. Plants turned out into fresh British tan, as described, will grow more in four months than in six by any other treatment. The plants, when turned out of their pots into the tan, were about eleven months old. The sorts were principally Montserrats, Black Jamaicas, and a few old Queens; the progress they made during the first three months was really astonishing, and all, except one, ripened their fruit from September to the 1st January. The year following, January 6, 1829, I tried the following experiment. The tan-bed was managed, as I have stated, for those planted out in February, 1828; the sorts were Montserrats, Black Jamaicas, and three or four Queens; and stronger than those of the preceding year, being about thirteen months old when planted in the tan. The same care was taken when turned out of their pots to preserve the ball of earth *with its roots undisturbed*. They were also planted the same depth, and the tan beat tightly about their roots with the hand when planted. In this state they were allowed to remain until the last week in March, at which time *every plant was carefully lifted out of the tan with a long-pronged fork*, by which means the primitive ball was preserved. The roots of some had extended nearly two feet along the surface of the fresh tan, from which they were *carefully disentangled*, and immediately planted in pots *one size larger* than those they were turned out of in the January preceding. After the tan was watered and forked over to the depth of two feet, they were again plunged up to the rims of the pots. *The check* the plants received by being disturbed whilst growing so vigorously may be easily conceived; and they, consequently, all showed fruit in the three following months, and ripened in July, August, and September. Not at all satisfied, on account of *the fruit being smaller* than that of the former year, I tried a third experiment, which indeed varied very little from the first. In the latter end of October, 1829, the same pit was again prepared, by

levelling the old tan, &c., and fresh bark to the depth of eleven inches was spread all over the bed; in this I turned out fifty plants, *out of their pots*, with their balls entire, and all perfected their fruit from the beginning of August to the end of October. Thinking, however, a great improvement might be made in this method of planting out in the tan, I tried the following experiment, which *fully answered* my expectations. At the time these plants were showing fruit, I added *two or three inches of fresh tan* all over the roots of twenty, beating it down with the spade; and the beneficial result was shown in the swelling of their fruit. When these were cut, the suckers growing on all the plants were of a prodigious size; and had I then *known the value of their produce*, by letting them remain *attached to the old stools*, their second fruits might have been ripened by the following October."

This is a long extract, but we do not feel called upon to offer an apology, seeing that it is Mr. Hamilton we would fain represent, and it is, perhaps, well that he should speak for himself: our comments thereon will be at least harmless, and the public will be in a position to judge freely for themselves. Before proceeding farther, we would beg attention to the italics, which we have superadded to the original text, in order to direct the eyes of the uninitiated to the chief features of the Hamiltonian plan. And now a few words to illustrate some of these matters before farther details. It will be seen, that the experiments here related were undertaken for a double purpose, viz., to test the productive powers of the pine grown in tan, and to ascertain if pines could be compelled to "show" through the medium of a check, without loss of size in the fruit. The tan matter appears to be established beyond dispute, although, of course, the question still remains whether it is the most desirable medium. This, it appears is, in a great degree, negated by Mr. Hamilton's subsequent practice. Mr. H., however, says in a note, "I used tan at Thornfield, but none in the new house here; but they like the smell of tan."

As to the check producing fruit, this is what, indeed, might be expected; in most fruits with which we are acquainted, a check on a healthy subject, after a fair amount of liberal growth, generally produces this result, light being in due proportion. The tyro may here learn, that in the case of the pine such was not accomplished without deterioration of size; this, indeed, agrees with the experience of all our most celebrated pine growers: the breaking up of the disrooting system some years since was the signal for an abandonment of the "check system."

Again: Mr. Hamilton gives this caution—"I wish also to observe, that when pine plants are turned out in the winter season, their growth is so rapid, that except they have plenty of air and light, the young leaves are apt to blanch. For several weeks after planting, the surface of the tan ought to be frequently stirred with a rake or long stick, to prevent any fungi breeding, to effect the escape of superabundant bottom-heat, to allow the atmosphere to have free access to the roots, and to keep the tan in a clean, pure state."

It may be here asked, why so much about the *tan*, if Mr. Hamilton has ceased to use it? This is a fair question, and we answer, because we think *tan-culture* still an open question; and also, because localities differ so much. Those who live next door to a coal-pit will hardly care for tan; but we can imagine cases in which parties would be justified in making a liberal use of it; moreover, Mr. Hamilton himself has never, as far as we are aware, totally repudiated its use, whether as a heating medium or for planting in.

We have been speaking all along of "notes" received from Mr. Hamilton, but we find it expedient to have recourse to his most useful little book; which, indeed,

should be well read by all about to embark in Pine-culture without any previous practical knowledge. Candid readers will readily allow for any little "slips of the pen" for the sake of the breadth of Mr. H.'s views; for no sooner is he studied carefully, than those hard fetters imposed by a time-honoured routine, seem to fall off one by one; and the would-be pine grower speedily acquires an amount of freedom before unknown. This, arising from a perception of its simplicity, makes us fancy that pots, crocks, shifts, composts, &c., are passing away like a dissolving view.

Pages 40 to 48 in Mr. Hamilton's second edition, now on the table, are occupied with experiments strongly corroborative of the planting-out system; in which, of course, pots, potting niceties, with other time-consuming matters, are dispensed with: and it is evident that if even Pine-culture were for the million, either this or some other high amount of simplification must be put in requisition. Of course, space will not permit many more quotations from the book, and we will proceed to finish our observations about cultural matters on the planting-out plan; and in a succeeding paper will just skim over the great essentials; or rather skim the very cream from Hamilton's dish, in order to leave the main features strong on the mind of the reader. After this, we do hope to hear of Pine-culture becoming a necessary portion of every gardening system with the middle classes. This, with the Orchard-house, are, perhaps, the two most prominent features in modern fruit-gardening; and surely THE COTTAGE GARDENER may fairly lay claim to having "performed its mission well" in these things.

We last week thought it necessary, in order fairly to elucidate the subject, to pop a few questions to Mr. Hamilton chiefly on the subject of after-culture on the planting-out system. We will give the enquiries and answers verbatim.

"1st. How long after planting before they require culture?"

Ans. All kinds would be better by a little soil on the surface once a year.

2nd. Do you advocate the use of tan up the stems?"

Ans. I used tan at Thornfield, but not now; they, however, like the smell of tan.

3rd. How about leaf-stripping?"

Ans. Be very careful of cutting your leaves.

4th. How about choice of suckers?"

Ans. Should never destroy a ground-sucker unless the plant was already too low in the bed.

5th. What number retained when plenty?"

Ans. I never leave more than three.

6th. Are they chosen by succession or quality?"

Ans. By quality.

7th. When are they removed or thinned out?"

Ans. I tear all superfluous suckers out when six or eight inches high.

8th. How many to a stool, on the average?"

Ans. Three; two stem-suckers and one ground.

9th. Do you ever water at root?"

Ans. I have watered at root twice this summer.

10th. Any plan for checking size in the crown?"

Ans. They want none."

Our readers will see how much I have to thank Mr. Hamilton; indeed, had he not been a very old and well-known friend such liberties could not have been taken. As it is, the only thing to regret is that we could not have the benefit of a regular chit-chat over the affair: distance, &c., precluded the possibility. Still, it is to be hoped that enough will have been stated to prove a pretty good guide to those seeking information. In our next paper on the subject, which may be deferred for a week or two, we shall work up some useful facts, which will throw farther light on the system: in the meantime, we invite young beginners to put what questions they

deem necessary on neglected points: they best know their own wants.

R. ERRINGTON.

MEETING OF THE HORTICULTURAL SOCIETY.—NOVEMBER 2, 1852.

WERE it not for the novelty of seeing a grand struggle for the prizes offered by the Society for the growth and improvement of the *Chrysanthemum*, no one, round London, would be tempted to go out-of-doors on such a day as this was—dull and dreary, with rain pouring down in torrents the whole day. The spirit of the *practicals*, however, was up to the boiling point, and, rain or no rain, they must see and enjoy the battle like true Britons as they are. So they mustered in great numbers; but, alas! the council of our Society are not of practicals, and of course they can hardly be blamed for not knowing the right time of the year for the *Chrysanthemums* to be in a fit state for competition. They knew that *Chrysanthemums* usually bloom in November, and that was all; and a show on the 2nd or 22nd of the month was the same in their unpractical brains. The editors of Moore's Almanack managed much better than this, by keeping snow out in the dog days! This blundering could not have happened at a worse time in our progress. The *Chrysanthemum* has lately become a fit subject for the gamblers in flowers, who, if they could but cook one prize flower up to the mark, would not hesitate to sacrifice twelve of their best plants; and, what is worse than all, their evil practices, to my own personal knowledge, go a long way to sacrifice the credit of the best gardeners in the country. We have had, lately, excellent treatises on the proper cultivation of this useful flower, in defence of practical gardening, and the Horticultural Society steps in, just at the nick-of-time, to second these attempts, and to stamp their value, and the character of our best gardeners; and, as if to prove their zeal, one of the best-grown collections of *Chrysanthemums* in England may now be seen in their own garden, but all to no purpose; and now it is of no use to try to back out of the scrape by saying that gardeners did not understand the rules. Gardeners did understand the rules, and blame me very much for tempting the Society to offer prizes for things out of season. Well, as I have taken a great deal of interest in the shows and meetings of the Society, enjoyed them myself, and endeavoured to make them useful to others, I must pocket this rebuke, and explain how we may get on better in future. Upon the average of seasons, *Chrysanthemums* are in their prime about the 20th of November, or say from the 15th to the 25th, and one week sooner, or one week later, affects *them* more severely than any other flower that has ever been exhibited; all *practical* men know this. It is true, that in large establishments in the country, flowers are very much in request late in the autumn, when ladies cannot go much in the open air, and that October is the worst month in the whole year for house flowers. As a kind of compromise, therefore, gardeners in such places sacrifice some of their earliest *Chrysanthemums* by a slight forcing, and then all that they will bear is only a cold house, such as a peach-house, or vinery at rest, and the doors open at both ends, day and night, and also the top lights a little open at night and on dull days. On very sunny days the top lights and one of the doors may be shut close, but not during the long dark nights. There is no way that a man could think of but I have tried to get in some *Chrysanthemums* by the first of November, and this is the only way in which I ever succeeded; just the reverse of what one would do late in the spring. I have had the *Queen*, *Bicolor*, and three other old varieties, not now well-known, in bloom by the 25th of October by these

means, but none of the others before the end of the first week in November; therefore, I trembled when I first heard of the Society's resolve to open a competition for them in the first week of the month, but concluded, that, as my practice lay at a distance from London, I might be mistaken, and that the flowers come earlier up here than with us far in the country. To make sure of how this stood was my first aim as soon as I saw the failure of this meeting, and there was no lack of London growers on the spot to consult. After exchanging notes with Mr. Chandler, of Vauxhall Nursery, the best authority in London for this flower, and other growers and exhibitors, it turns out that none of them would expect so early a bloom as myself, and some of them maintain that if even very slight forcing were attempted here, mildew would be the consequence and reward in many places round London. This settled, and knowing that "we must all live and learn," the next *Chrysanthemum* exhibition or competition in Regent-street must be held somewhere between the 15th and 20th of November. Now, I think I need not blush for saying that we had only one solitary plant of the common *Chrysanthemum* at this meeting, and that ought to be noted down as a very early one, and I can say it is a very good one—the name is *Madame Derreux*, a fine-shaped flower, flat and imbricated on the face, and of a buffish-yellow colour.

The value of the pretty *Pompones*, the grand, and great-grand-children of Mr. Fortune's Chusan Daisy *Chrysanthemum*, was never better exemplified than on this occasion. All kinds of *Chrysanthemums* are ten days later this season round London than usual; and we have seen already that we can now depend on these *Pompones* from the middle of October, beginning with *Hendersonii*, which was a brownish-yellow on the last occasion (19th October). The same plant was in fine bloom to-day, and age turned the blossoms to a clear yellow. *Hendersonii* should, therefore, be held in great demand for a mother breeder till we get seedlings that will flower from the first of October. Another peculiarity, and a valuable one, appeared in this race, for the first time, on this occasion—sweet-scented flowers. A beautiful little, light lilac flower, called *Le Maine Bété*, has a delicious scent, something between that of orris root, and violets. It was in a collection exhibited, but not for competition, by Mr. Chandler, of Vauxhall Nursery. He had another one called *Ninon*, which will be a great favourite with the ladies in their nosegays and wreaths, for evening head-dresses. It is as flat as a looking-glass, the first essential for a wreath *Chrysanthemum*. The size is half-way between *Bicolor*, the only one of the old sorts that did not look vulgar in a wreath, and a Bachelor's-button. The colour is a delicate French-white. No flowers are more suitable for making regular nosegays than these button *Chrysanthemums*, particularly the pure white, as *Argentine*; French-whites, like *Le Maine Bété*, the sweet one; and the mottled rose, as *Bouton de Venus*; but the great bulk of them are yet of different shades of yellow and buff. We expect a large muster of them at the next meeting on the 7th December, and then I shall take the names of the best varieties, and mention the most distinct colours.

The great lion at this meeting was a *Hybrid Æschynanth*, from Mr. Pince of Exeter, called *Splendidus*, a well-bestowed name. It is by far the best of the family, and shows what can be done with judicious crossing, for which the genus seems to offer great hopes. I did not hear the parentage of this beautiful cross stated, but it ought to have been told. A practised eye could see that *Grandiflorus* was one of the parents; and when not in flower, the cross might easily be mistaken for that species; and that will sufficiently explain the aspect of the plant. The flowers stand more upright than in *Grandiflorus*; they are also much larger, a

greater number of them in a head, and they all open at the same time in each head. The top part of the flower is a rich, soft, crimson-scarlet, lower down, fading into orange-scarlet; and the bottom of the tube ending in a shaded orange colour; altogether making the richest cross that has appeared since the purplish-crimson water-lily at Chatsworth, called *Nymphaea Devoniensis*. There were twelve plants of it in bloom, all from cuttings this summer; and all in 60's, or three-inch pots, showing what a free bloomer it is. Their heights might be from six to eighteen inches; and the largest heads had from ten to twelve open blooms each. Now, as it is lawful, by common consent, to make large specimens of *Achimenes* from a collection of plants, individually small, by planting so many of them in one pot just as they show for bloom; and knowing that some of our best gardeners cannot flower the stronger *Æschynanthus* but indifferently after they come of age; being also quite familiar with the fact, of which Mr. Pince seems to be well aware, that all *Æschynanthus*, whether strong growers or otherwise, flower much better and with greater freedom on single shoots and in the smallest pots; why might not the law be extended to these beautiful *Æschynanthus* as well as to the *Achimenes*? I mean for competition plants. I recollect very well when the parent of this cross, *Grandiflorus*, first appeared, that I made a large number of cuttings of it about the middle of May, and before they were out of their first shift. They all flowered exactly as did the plants now exhibited by Mr. Pince; but before they were allowed to be seen I made two fine specimens with them, in No. 12-pots, and they were much admired that autumn in the conservatory. The two pots were more than half-filled with drainage, so as not to overwhelm the roots with too much soil; about two inches of very rough peat were put over this; then the little plants with very firm balls were turned out of the small pots, No. 60's; the balls were placed on the rough peat, and the spaces between them filled in with equal quantities of peat, sand, and leaf-mould, without any lumps, the surface of the balls being covered half-an-inch. The tallest plants were put in the middle. When the whole were staked, and had a week or two's growth, they were fit for the Queen; but the upshot of the thing was, that in after-years, my worthy employer, Sir W. Middleton, pretty nigh pulled my ears because I did not, or could not, make him such fine specimens with old plants. The like had happened before that time with *Æschynanthus ramosissimus*, for which I paid five guineas to Mr. Tate, of Sloane-street, or at the rate of one guinea an inch. All this I had forgotten till I saw how cleverly Mr. Pince got up his beautiful cross to surprise the Londoners. But I am perfectly sure that this is the grand secret for amateurs and for many gardeners to make the best of all the species of the genus. It is also by far the easiest, as there is no risk, provided that the plants are not turned out of the little pots until the flowers are near their full size. This will not do, however, for competition, as it is against the law to have more than one plant in a pot.

From Mr. Veitch we had a fine plant of the *Vanda cœrulea* in beautiful bloom; and, as is usual with this liberal firm, they always tell the easiest and best way to manage their new plants. They sent to say that the degree of richness in the flowers of this new orchid is according to the heat applied—the more heat the fainter the colour, and the reverse. This may account for what we saw at the last meeting, two growers having each a different variety of *V. cœrulea*, one with a deeper blue lip than the other. If this can be traced to temperature, this orchid should be treated as a Mexican. At any rate, it always gives pleasure to hear how such things have been managed.

We had also a large plant of *Calanthe vestita*, from

the Messrs. Veitch, having large spreading white flowers on long shoots trained on sticks, each flower having a scarlet eye, so to speak. Also a new stove plant, belonging to the order of Cinchonads, and putting one somewhat in mind of *Pavetta caffra*. Mr. Weeks, the celebrated hothouse builder of Chelsea, and whose name has reached the ends of the earth for his success in flowering the Victoria water-lily in an open pond, sent *Zygopetalum crinitum*, a closer growing orchid, and with smaller flowers than those of *Z. Mackayi*, but otherwise not unlike them. Also *Maxillaria picta*, with flowers as strongly scented as those of *M. aromatica*, and, therefore, very desirable; and *Oncidium ornithorhynchum* with small purplish flowers of no great account.

There was a nice *Hybrid Begonia* from the Society's garden, with a wrong parentage given. No one who has the smallest idea of how the pollen tells in this genus, could go so far wrong as to call this a cross between *Manicata* and *Cinnabarina*. There is not a drop of the juice of *Manicata*, or of any species belonging to that section of the genus, in this cross. Nevertheless, the cross itself is a very desirable *Begonia* flowering at this late season, and it looks as if it were much easier to manage than *Cinnabarina*. I saw some splendid crosses from this genus this autumn, in the west of England, and I know of no plants more easy to cross, or from which better results may be expected.

There were two good specimens of late *Achimenes*, from the Society's garden; the old *Coccinea* and *Liepmanni*, and some good plants of the perpetual *Tree Carnation* in three or four varieties. Every body ought to grow these *Tree Carnations*, as they are called, as they flower late and early, and almost all the year round. They were from the continent a few years back, and very little heard of in country places. *Veronica Andersonii*, with five racemes of lilac and blue flowers, after the manner of *Speciosa*, was also from the Society's garden, and samples of the little carpet-plant, *Cochlearia acaulis*. Everybody is now asking where seeds of this little wonder can be had, but I cannot tell. Most of the Fellows of the Society ought to have it by this time, as well as all the London seedsmen. *Bilbergia Moreliana*, a late acquisition from the continent, is as good as any in this genus, the beauty being more in the broad scarlet bracts which accompany the flower. And, lastly, *Cactus truncatus*, a fine plant in good bloom, telling how close we are on the winter.

Of *Fruit*, we had Pine Apples, Grapes, Pears, Sweet Limes, Mandarin Oranges, Citrons, and white Alpine Strawberries, with a Clingstone Peach, which was sent as a Hybrid between a peach and an apricot!

No wonder that gardeners, after a change, or confusion of tallies, should make mistakes about crossed *Begonias*, when people of education will entertain such absurd notions as that a peach could be crossed with an apricot—or that any plant on the face of the earth can ever be crossed with any other plant not of the same genus. Those who simper out extravagances about "*bi-generic crosses*" merely use hard words as a veil for ignorance.

There were three beautiful *Queen Pines*, from Mr. Fleming, gardener to the Duke of Sutherland, at Trentham, two of which were exactly of the same weight, 4lb. 6oz., the third one was heavier by 8oz. Every pine-grower in the kingdom ought to have seen these, if only to puzzle them to know how he can grow such pines, with crowns not bigger than the head of a starling. Mr. Fleming has some grand secret for throwing the whole strength of his plants into the fruit. Mr. Dodds, gardener to Sir J. Cathcart, Bart., sent two *Queen's Pines* of the very same weight as those sent by Mr. Fleming, and more ripe, with crowns rather less than usual; but a smooth-leaved *Cayenne Pine*, from another grower, put these beautiful *Queens* to the blush—in looks, in size, and in weight. It was 6lb. 4oz., and

as handsome a fruit as ever went to table. Many gardeners cannot grow this pine at all. If it gets the least too wet or too damp in winter it turns sulky, and they cannot bring it round again. There was a basket of the true *West's St. Peter's Grape*, and one of *Muscats*, neither of which would be quite ripe before next Christmas. This rainy, cloudy, and muggy autumn, must have taught a severe lesson to all those gardeners who maintain that late grapes should not be forced. There never was a greater mistake. Keep them from "breaking" as late in the spring as you please, but when they do come into leaf, they ought to have as much heat and moisture as air plants, until the fruit begins to turn colour. Even greenhouse grapes, as the Hambrough, are improved by a push from the first coming of the bunch to six weeks after the setting of the berries.

The *Citron* tribe were from Mr. Piper, gardener to E. V. Digby, Esq., of Mintern, Dorsetshire, I happen to know them both, but I cannot tell who is the best gardener—the master or the man. They are both bests, and their large Citrons and Mandarin Oranges were very much admired at this meeting. A gentleman in the room told me that they grow the Mandarin Orange, at Mintern, in the greenhouse as freely as gooseberries, and that he had a basketful of them last August. *Citrons*, after they lay twelve months in preserve, make a beautiful dish at table, either whole or quartered; if whole, they will keep I know not how long. Ordinary *Limes* are better than Lemons in the kitchen, and, better still in whisky-punch, or anything good and hot with a spoon in it; but sweet Limes, like those from Mr. Digby, are scarce articles, and are as good as the best oranges.

There was a fine-looking *Yellow Turnip*, called the "Orange Jelly," of which they spoke very highly. It was raised by Mr. Chivas, of Chester. *Celery*, *Spinach*, *Kohl Rabi*, *Peas*, and some other vegetables were shown, with a King or Queen of the *Vegetable Marrow* tribe, weighing 108 lbs.—it looked like Burn's "Great chieftain o' the puddin'-race"—a Scotch haggis. D. BEATON.

OXALIS BOWELL, AND OTHER SPECIES.

ENQUIRIES as to these not blooming; and complaints as to their not growing, not forcing, and producing fine foliage but indifferent flowers, I hope will be met by the following short outline of culture.

For this beautiful species, as well as for others the most charming of the family, we are indebted to that land of bulbs and heaths, the Cape of Good Hope. The whole have more or less of a peculiar acid taste, which, when not in excess, is very agreeable. Even the most uninitiated may form some idea of the form of the leaves and flowers of the group by examining those of the little *Oxalis Acetosella*, found often so plentifully in woods, but no idea could thus be formed of the magnificence of the present species, with its large crimson flowers. It is generally described as a plant only a few inches in height, but, though it has no stem, it is no uncommon thing to see the flowers rising on strong stalks to from twelve to seventeen inches in height. Few things will beat it, either in a greenhouse or window, on a fine bright day in autumn. It is generally considered an autumn-flower, but, like many other Cape bulbs, the time of *blooming* depends upon the time of *resting* and starting into growth. By successions, I have had it in bloom for seven or eight months out of the twelve; a *clashing* of the bulbs carelessly together destroyed the arrangement. They can only be brought into this succession mode gradually, as each bulb requires the greater part of a twelvemonth to start, grow, bloom, mature, and rest itself. Forced they may

be, but they do not like it; an anxious amateur would, however, soon get over the little difficulty. Even should his bulbs start much about the same time, yet the keeping of a part as cool as to be safe, and giving the others extra heat, will make in the first season a considerable difference in the time of blooming; this first lot may be then kept separate, and treated in the same manner another season. Thus we have seen it bloom from May to December; the medium between these two extremes is the period when it will bloom best with little trouble. In sheltered situations it might then do out-of-doors. I will confine myself to the growing it in pots.

1stly. *Choosing Plants*.—Prefer growing plants, or even plants finished flowering, but with the foliage green; the reason is, that thus you may be sure of well-ripened bulbs by such treatment as will presently be recommended. Failing such plants in pots, choose the *largest*, *firmest*, and *brownest* looking bulbs you can find. If soft, or bagged with watery juices, the consequence of cutting away the foliage too early, you may get foliage, but your flowers will be weak and scanty.

2ndly. *Starting into growth*.—Unless particularly wanted, I would not advise this being done during the dark months of winter. If growth commences in March, bloom may be expected in June and July. It is best to place the tuberous bulbs, with their small ends uppermost, in pans or saucers covered over with earth, rather dry than otherwise, and just kept in that state. A moist, warm place will cause them to shoot sooner; but in the early part of the season I would not advise an average temperature produced by fire heat above 50°. It is better to hurry growth by closeness, warmth, and yet plenty of light afterwards. As soon, however, as the bulbs begin to shoot, before roots commence to form to any extent, they should be placed

3rdly. *In their flowering-pots*.—These should range from six-inch pots for windows, to those from eight inches to twelve inches for greenhouses. Drainage of course must be attended to. Over the drainage a layer of old dried cow-dung, in small hard bits, mixed with charcoal, will be an advantage. The *soil* should consist of equal parts of sandy fibry loam, and fibry peat, with a little charcoal; but fine plants may be produced from sandy well-aired loam and a little rotten leaf mould, or old cow-dung. The soil should be neither wet nor dry. I must try and explain what I mean. "Oh, something about minding pennies, and pounds will take care of themselves." Well, just so; I am no advocate for the contracted and miserly; but, somehow, without these *littles* we cannot get on in gardening. But to the soil: take half-a-handful and close your fingers over it firmly; if on opening your hand the soil remains all in a piece, shewing the marks of your fingers, but falls to pieces when you lay it gently down on the potting bench, it is just in the right state; if it will not remain in one mass in your hand, it is *too dry*; if, when you place it on the bench, it remains without falling to pieces, it is *too wet*. In the one case, you must damp with a fine rose; in the other, you must dry; and either operation will save you future labour and uncertainty. Fill the pots with this soil to within about two inches of the surface, firming it a little; then place the bulbs, small ends upwards, equally over it; about eight bulbs will fill the largest pot well, and yield a large mass of flowers; but if the bulbs are small, add a few more. Sprinkle in the earth amongst them, and over them so that their points are covered. By-and-by, when the flower-stalks are showing, and the leaves are getting the size of a half-penny, the soil will have sunk a little so as to afford room for a top-dressing of old cow-dung, and over that the fastidious may throw a sprinkling of fine soil just to hide it.

4thly. *Watering*.—Of course you will water none

when the bulbs are not growing; but as they are started and potted moisture will be requisite. Here now will appear the importance of what was just now said about soil. If dry, with common watering when would you get it equally moist? If wet, it would dry and crack on the surface; and ten to one but the first wielder of a water-pail that passed that way would render bulbs and soil alike as comfortable as if they had been sunk a foot beneath the surface of a plashy morass. But use the soil indicated; take the precaution, in addition, to place your pots in a pit or frame where thorough air is admitted, the atmosphere is somewhat close and moist, and if the pot is plunged in ashes, &c., all the better. Then the soil will just be in the position for roots to ramify in; and you may safely lock up the water-can until the leaves, getting to the size of a shilling, begin to show that they need a refresher, and by that time roots and everything will have gone also well, that it would require a peculiar clumsy knack indeed to be able to sour or sodden the soil. As the leaves increase in size, and the flower-stalks shew themselves, more air and water will be needed. Pouring it over the dressing of cow-dung will give strength to the flower-stalks after they have fairly started; and after the first blooms appear, manure-watering may be given twice a week in addition. When the flowering is over and the first withered leaves appear, water must be gradually lessened; but some should be given so long as the leaves are green, giving them during this period a good open position, and allowing the plants to remain in the pots several weeks, if not altogether after the foliage has decayed.

5thly. *Position and Temperature.*—As now indicated, when in a dormant state, they cannot be better than in the pots in which they grow, and turned on their broad-sides to keep the soil dry. But, if for economy, the pots should be otherwise wanted, after the bulbs are thoroughly ripened and partly rested, they may be carefully removed, and packed in dryish earth, and kept anywhere where neither wet nor frost can reach them. The earth, in either case, will prevent the juices of the bulbs being evaporated, which, though it might not oppose the production of flowers, would be apt to deprive them of strength, and the foliage of healthy luxuriance.

The plants grow freely where the average night temperature does not fall much below 50°, with a good rise for sunshine; but when flowering, or advancing towards it, enjoys the clearest sunshine and the highest temperature of our summers. A cold pit may, therefore, be said to be its chief delight from May to the middle of September, where it may have full light and air when blooming, and a slight shade and a closer atmosphere when growing. In October the plant will do best in an open warmish greenhouse. I have never seen it better than in sunny days in November and the beginning of December; but then it stood in a rather dry house,—a combination of a plant-stove and a greenhouse, where the temperature at night was seldom below 50°. Even then, at that season of the year, though the bloom opened in clear days, they never became fully expanded, unless during sunshine. These facts will show our greenhouse and window friends the importance of blooming this plant in summer and autumn.

6thly. *Training.*—I have allowed the flowers and leaves to droop; but, unless the plant was elevated above the eye, nothing was gained by the mode, if even then. The simplest, and perhaps the best plan is to place a number of small slender sticks round the inside of the pot, and also several in the centre; connect these together with fine thread; the leaves and flower-stalks will grow through and among them, and will thus be held fast, while the supporting medium will soon be entirely encircled.

It would have been out of place to have said so much

about *O. Bowiei*, at this season, in this department, were it not that a similar mode of management is applicable to the whole bulbous group of *Oxalis*, with, perhaps, the exception of using more peat for the tenderer kinds. They are mostly all such beautiful things, both for greenhouse and window, that I should be glad both to see and have a collection of them; and most of them can be well grown in six-inch pots, and take up but little room in comparison with *Bowiei*. What, for instance, at this season, in a warmish greenhouse or window, can be more beautiful than *O. lobata*, with its lobed leaves, and large yellow flowers; or *O. sericea*, in spring, with its glittering silky foliage and pretty yellow flowers; or *O. tricolor* during the winter and spring, especially in clear sunny weather? As I have already mentioned, many in time may be made to bloom at any period, according to the time they are rested, but it is not advisable to have many in the dead of winter, as it requires a fair temperature and good light to cause the blooms of the best to expand freely. How interesting might many become in autumn and spring to those friends who have but little space at their command. I will, therefore, conclude with a short list of dwarf kinds that bloom freely in autumn and the first months of winter, in spring, and in summer.

In Autumn.—*Lobata*, mentioned above; *Asinina*, ass-ear-leaved, yellow; *Carnosa*, flesh-coloured; *Fulgida*, crimson; *Hirta*, yellow; *Rosacea*, rose-coloured; *Variabilis*, white and red.

In Spring.—*Sericea*, already mentioned; *Canescens*, hoary-leaved, purple flowers; *Flava*, yellow; *Incarnata*, flesh; *Multiflora*, lilac.

In Summer.—*Fuscata*, brown; *Miniata*, vermilion; *Tenella*, lilac; *Rubra flava*, red and yellow; *Darwalliana*, crimson.

Without adding more, I might recommend *Fruticosa*, a yellow semi-shrubby one, to those having the heat of a cool stove at command in winter, and a greenhouse herbaceous one named *Floribunda*, which is easily increased by suckers and division of the roots; the flowers are simple and pink in colour; but the singularity about it is twofold; first, as the plant grows it produces its flowers and leaves in a bundle at the point of the shoots; and secondly, as years roll on this habit gives to the stem of the plant more of the character of a miniature *Palm* than an herbaceous plant. I have had these stems from a foot to eighteen inches in length, and as smooth as a mop-handle; in fact, altogether the plant was too like the mop, handle and all; but still, in a common greenhouse, with rough treatment, it was scarcely ever destitute of flowers.

Oxalis Crenata, once lauded for its edible tubers, and which seemed driven out of the field by *Oxalis Deppei*, but of which little has been seen or heard lately; so difficult is it to get *artistes* of the kitchen, or gentlefolks either, to patronise new-fangled things, IF OF HOME BRITISH GROWTH; though certainly the flowers and points of shoots were nice and pretty too in a salad; the stems made no bad tart; and the tubers, well dressed, being destitute of acid, were immeasurably better to simple tastes, than many of those unpronounceable *kick-shaws* which epicures make so much of, because they pay so nicely for them. These, no doubt, at the right time will be introduced to the notice of those desiring it, by our able fellow-labourer, Mr. Robson. R. FISH.

CONIFERÆ.

(Continued from page 87.)

JUNIFERS.—A large genus of handsome, mostly hardy shrubs; the commoner kinds are grown in almost every garden, and are well suited for that purpose, both on account of their beauty, and being perfectly hardy;

but they grow best about midway between the mountain-top and a low boggy valley. As might be expected, they were well-known to the ancients, and are mentioned in the Bible in the history of Elijah, who hid himself under a tree of this genus when persecuted by the King of Israel. It is mentioned, also, by Pliny, who says that it grew in Spain to a large size. Large quantities grow in the north of Europe. Some species are found in the same locality as the *Cupressus torulosa* in Asia, on the Bhotan Hills, and some are found in North America, so that few plants of any genus are more widely distributed. Many of the species produce timber, which, though small, is remarkable for its durability. The wood has a strong aromatic smell, and when burnt in rooms is said to be fatal to noxious insects. It is used, also, to give hams and bacon that peculiarly smoky flavour so much esteemed by epicures. It is well-known that Juniper berries are used to flavour the spirits called gin and Hollands. To all these uses the plants of this genus can be applied, hence they are interesting, both on account of classical associations, as well as the various uses to which they are applied. I well recollect one use to which the young branches of *Juniperus savina*, the Common Savin, was applied, namely, to destroy worms in the intestines. I had to swallow a tea-cupful three mornings in succession for that purpose, and it was a good remedy, though a dangerous one, at least, I have been informed so since I grew up to manhood, I, however, never felt any ill effects in taking it, the worst was its (to me) very nauseous taste.

The family of Junipers are well adapted to plant in front of taller-growing Coniferæ in the pinetum. They thrive best in a sandy loam, moderately dry, but will grow in almost any soil not absolutely wet. In the beautiful valley near to Alton Towers, there is, or was, a beautiful avenue of the *Juniperus communis*, var. *Seucica*, or *Swedish Juniper*, on each side of the walk leading to the Chinese Temple. Few plants to form an avenue could have a finer effect. This valley was originally a rabbit-warren, but the late Earl of Shrewsbury had it enclosed, broken up, and formed into pleasure-grounds with the finest effect. On the south side, he built a range of ornamental plant houses, with a terrace-walk in front, overlooking the lower part of the valley; and on the north side he built a Swiss cottage, of considerable size, in which there is, or was, rooms for visitors to sit down and refresh themselves. From the platform, in front of the cottage, the visitor had a fine view of the valley—its walk, avenues, conifers, plant-houses, and a lofty Chinese pagoda in the bottom. When I was there, a real, *bona-fide*, aged Welsh harper lived in the cottage, and favoured us with several ancient airs on his harp. This part of the grounds has always most deservedly been greatly admired. At the head of the valley is a fine marble bust of the earl, with this inscription, "He made the wilderness to smile." It is now nearly fifteen years since I had the pleasure of visiting Alton Towers, and I enjoyed such a gardening treat, that the scene is as vivid in my "mind's-eye" as if I had been there only a few weeks ago. I hear the present earl has improved (?) the place much, and, if all be well next summer, I will go and see, and take some "jottings by the way." Two things I should be glad to see there—a good collection of orchids, and an extensive pinetum. The sides of the valley would just be the site for the latter. This digression was brought about by the Swedish Junipers, so let them bear the blame, whilst I escape by turning to describe the species, individually, of this interesting and beautiful tribe.

JUNIPERUS ALBA (Whitish Juniper). There is, or was, a plant of this name in the Gardens at Chiswick, and that is all I know about it. It is not mentioned in any catalogue; at least, I have not seen it.

JUNIPERUS BERMUDIANA (Bermuda Cedar).—One of the few species of this genus that is not quite hardy in this country, introduced so long ago as 1688. It has lived in the open air, in Devonshire, and probably would exist in Ireland. It is the tree that produces the wood from which the cases for black-lead pencils are made. It is also used largely as partitions for rooms in the West Indies, because insects will not attack it.

JUNIPERUS CANADENSIS (Canadian J.).—A hardy, very low shrub, seldom exceeding three feet.

JUNIPERUS CERNUA (Drooping J.).—This is the *J. flagelliformis* of gardens, and is a drooping, curious tree from China.

JUNIPERUS CHINENSIS (Chinese J.).—A native of China and Japan, perfectly hardy and very handsome, growing, in its native country, to the height of thirty feet; but the tallest I have ever seen here was ten feet. It forms a pyramidal tree, densely clothed with branches and foliage, and ought to be in every collection. It should be planted in a conspicuous situation by itself, so that the eye could see it on every side, because there is no coniferous plant that grows so symmetrical, even, and compact.

There are two varieties, both handsome trees, named respectively *Juniperus femina* and *J. Smithii*, but they are rare.

T. APPLEBY.

(To be continued.)

THE PETUNIA.

(Continued from page 107.)

Soil.—In cultivating plants, the most important point is to procure the proper soil. Formerly, the directions given for most plants in this particular was "good garden mould," but in these days the enterprising and zealous grower of plants requires something more explicit and precise; for most growers are aware that soils suitable and health-inspiring for one plant would be death if given to another. Thus, rich compost, used to pot Heaths in, would soon destroy them, whilst, on the other hand, the soil proper for Heaths, and similar fine-rooted plants, would starve, and very likely kill such plants as Carnations, Auriculas, Polyanthus, and, lastly, Petunias. But then, in order to give a suitable soil for such plants, several kinds of soil must, according to the rule of experience, be mixed together; and this mixture is very properly designated by the word compost, the constituent parts of which are many, to suit the various and numerous plants called florists' flowers.

I think, however, the various composts might be much simplified. Some of the older florists, Emerson particularly, recommend such things as seem absolutely monstrous to pot such delicate plants in,—such, for instance, as sugarbaker's scum, blood, night soil, and other strong stimulants, all of which, he says, should be exposed for such a long time to the atmosphere that I opine very little would remain any way different or more nutritive than well-rotted simple hotbed dung, or, what is still better for more delicate plants—such as Auriculas, for instance—well-decomposed tree leaves, usually called leaf mould. With these few remarks on soils, combined under the name compost, I shall proceed to describe what I have found suits the Petunia as well as need be desired. Loam procured from the surface of a pasture, the grass to be taken with it, and the upper layer two or three inches thick only; to be procured in the earlier part of the autumn. This should be laid up in the compost yard for twelve months, and be turned over three or four times during the year. And here I feel it is my duty to digress briefly to state, that the turning over loam, or any other ingredient in a compost, should never be done in wet weather, and for this

reason—the upper surface being full of moisture, and buried at the bottom of the heap in that state, hardens or runs together into a close, lumpy state, into which the beneficial gases of the atmosphere cannot enter, and, therefore, the turning over the heap is positively injurious, and that to an extent that few amateurs are aware of. Turn over these composts, or the more simple soils, loam, peat mould, vegetable mould, or even dung itself (unless it be stable litter in a very dry state), when the surface is moderately dry. A very good time or season to turn the various compost heaps is in a dry frost, without snow. If during such a time the heaps can be turned over till every part has been frozen in its turn, the soils will then be, when a thaw takes place, in beautiful order, and the work of decomposition will have progressed wonderfully. By having this done properly, and at the right times, I have had tenacious loams mellowed and pulverised, and made fit and in good condition to mix with other lighter ingredients in one winter's exposure. And I have also had tree leaves mellowed and decomposed by such attention, in one year, quite as much so as without such care during frost the same material would have taken two years to bring into a state fit for use. The old proverb, *Procrastination is the thief of time*, applies, perhaps, more to gardening operations than any other business.

The loam for the *Petunia* should be rather light, and should be used whilst the roots of the grasses are visible, that is, about one year after it has arrived into the compost-yard. Of this, as a gardener would say, beautiful loam, take one-half, add to it one-quarter leaf mould, one-eighth well-decomposed hotbed dung, one-eighth sandy peat, and as much sand (river would do) as would give the compost a sandy character. These component parts may either be mixed two or three months previously to the time of potting, or be mixed the very day it is wanted. In both cases, let the mixing or compounding take place when the materials are moderately dry. If there should be a continuance of wet weather, let a sufficient quantity of each be brought into the potting room, or some other place sheltered from wet, a month previously to the potting season, in order that it may dry gradually, and so become fit for use.

T. APPLEBY.

A CHAPTER ON PEAS.

NEXT in importance to the potato, and certainly not less thought of when they first make their appearance, "a dish of green peas" forms a sort of epoch whereby we date the advent of summer, and the introduction of the various products common at that time. Besides, the first dish of green peas is a no less remarkable addition to the table fare than the first game of the season; and though the appearance of the latter may be counted on with a certainty as being forthcoming on a particular day, defined by statute, the introduction of green peas is not in any way secured by such protective laws. Acting, therefore, in the spirit of such liberal enactments, the skilful cultivator of late years has endeavoured to hasten on this crop by all the means he can command, and one of the most important things he looks to is the possession of a good, useful, early kind of pea, to sow at the fitting time. Now, though in this case, as in all others, when anything like a demand exists, there is no lack of variety of names, pandering to the capricious taste of an unsteady public, seedsmen have met their views (or attempted to do so) by multiplying varieties to an endless extent. Of course each succeeding new one is said to be so many days earlier than any that preceded it, which, if they had all proved true, we ought by this time to have had green peas before the usual time of sowing, if we were allowed

to reckon these respective days backwards! It would be as absurd to expect these accumulations of utility realised as it would be to look for railway speed increasing so as to land a passenger safely at the end of a long journey some time before he started from the other, although we have been told of an American who maintained the probability of such a thing happening, from *calculations* he had made of the rapid increase of speed of late years, yet I do not deny that some advance has been made in the right direction in the matter of green peas, and probably further progress may be made that way, so as to induce them to hasten their period of usefulness. At all events, enterprise must be directed that way in some shape, otherwise a retrograde movement will be the consequence. I cannot report any very material change in the earliness of the best variety of pea of the present day, with those in use some twenty years ago, yet they may be a trifle; besides which, unless some new varieties be introduced, the extreme old ones degenerate, the same as fruits and other vegetables; but this anxiety to produce new kinds has gone too far: sorts have been puffed upon us differing in no respects from those preceding them. While this has been done by the careful and conscientious trader, less scrupulous parties have been coining high-sounding names, and issuing half-a-dozen kinds out of one bag, with an avidity which none but John Bull would tolerate. However, there are numerous honourable exceptions to this rule, as well as careful and enthusiastic cultivators who spare no pains to increase the utility of this and other vegetables. To this party we are mainly indebted for the position we stand in as regards quality, earliness, and the other improvements imparted to the objects of their attention, still it must be admitted that peas have not benefited much.

The *Early Frame* of a quarter-of-a-century ago was often found in pod, and fit to gather, about as early as the most fashionable-named kind of the present day; and why not?—the seasons have not changed so much for the better yet, and they are of much more importance to the well-being of a crop than all the horticultural skill of the world, however well directed and applied. The season, by which term I mean the state of the atmosphere, has not undergone any material change; and though we now live in days of steam and galvanism, yet Nature's operations develop themselves in a way which alike baffles our skill to hasten or retard, when the ordinary agents by which she works remain unaided and unchecked.

In the case of peas for the first crop, our object is to promote their earliness; and, in doing so, one of our first duties is to supply them with a piece of ground containing as much warmth as the means we have at command will allow. Now, it unfortunately happens, we cannot do much that way; we cannot impart heat to any great amount, but we can, to a certain extent, prevent its being absorbed or withdrawn. An undue amount of cold stagnant water is at variance with the early production of any crop whatever, therefore, whenever that threatens to prevail, means must be taken to remove it. Ground for early peas must be well drained, either naturally or artificially; if by the former means, so much the better. Shelter, again, tends to warmth. A wall reflects back a considerable number of the sun's rays thrown upon it, therefore, what is called a south border is preferable to an open square, these requisites being at command, and the ground having, by previous digging, &c., been rendered as fine and open as possible.

No time must be now lost in sowing the seed, as, by a number of experiments, I have found the middle of November the best time to sow peas to stand the winter. In doing this, observe to sow them thicker than the usual spring or summer crop, the many mishaps they are

liable to rendering a few more necessary to meet emergencies. This, however, must not be carried into excess, I have seen the fatal results of this—sickly seedlings, rising up as thick as small saladings, become an easy prey to the various enemies they have to encounter in their untoward growth. In sowing in wet weather, or when the ground is very wet, it is very good practice to sow the respective rows as the ground is being dug; and if they are sown a little deeper than usual it is all the better, and the seed being covered with coal ashes is some protection from the enemies they will hereafter meet with, a little soil being added likewise, which, moreover, is often covered with a mixture of soot and ashes when the plants make their appearance—this is to make them more distasteful to the enemies preying upon them. Rows about three-feet-and-half apart are at a distance sufficient for the first crop, which ought not to consist of any tall-growing kind, unless strongly recommended by some one who has had experience in its growth. For my part, I prefer those having the habit, &c., of the old *Early Frame*, as being the best for winter; this useful old sort is evidently the parent of the many kinds now before the world. The last few years I have found *Warner's Early Emperor* the earliest of any that I have sown, and I generally sow some three or four sorts at a time, to test their qualities that way. *Isherwood's Railway* I have heard spoken favourably of, but have not tried it; but the *Racehorse*, *Warwick*, and *Prince Albert*, are all behind the *Emperor*. One thing is to have the seed genuine to its kind; if one-half the kinds we have are taken out of a bag of "Charltons," which, it is feared, is too often the case, we may look in vain for that difference in growth, &c., which constitutes a separate variety.

Observe, that in my attacking the dealer in seeds, I am dealing a blow likewise at those whose rage for novelty or variety prompt them to such a course. What occasion has any one for a dozen kinds of peas? A good early sort, followed by one or two good bearing ones, which had better be of the blue or green varieties, as they are more esteemed at table in a general way, is quite sufficient. Now, in making the above remarks on peas to stand the winter, I am perfectly sensible that in some very cold and exposed situations, the injuries they are liable to, from the elements and other sources, render it a more safe course to sow some in pots, boxes, or other contrivances, in heat, in February, to plant out when the weather admits it. But in all cases where a well-sheltered dry border is at liberty, in a latitude anywhere south of the Humber, it is advisable to sow a good breadth at once. In dry situations, in Kent and other counties bordering London, whole fields are sown at this period to pick for the market of that great metropolis.

In conclusion, I may add, that a few *Beans* may also be sown at the same time, and under circumstances similar to the above. The *Long-pod* or *Hangdown* is more esteemed than the *Mazagan*—though, perhaps, scarcely so hardy or early. J. ROBSON.

"I WANT FOR NOTHING."

By the Authoress of "*My Flowers*," &c.

ONE of the most interesting cases of cheerful and happy affliction that I ever witnessed became known to me a very short time ago, and I wish I could transport some of my readers to the "cottage of content," that they might learn a lesson of thankfulness for the lighter trials they may have to bear, and, at the same time, see what may be done under very adverse circumstances when the heart is right with God.

I was walking a few days ago through part of another parish, when I met a respectably-dressed young woman, with a walking-stick in her hand. I was passing on without taking any farther notice, when she stopped me by saying,

"If you please, can you tell me whether I have passed Mr. Wallis's gate?" I replied, that I did not know who lived in the cottage we were standing near, but that she had passed the gate some little distance; "but," I added, struck by a sudden idea, "are you blind?" "Yes, ma'am," she said, "quite blind."

There is something that touches the hardest, stoniest heart on seeing a person who is blind. Helpless; cut off from so many enjoyments of life; dependant on others for everything; defenceless, and exposed to a thousand perils, the blind are endowed with an interest in the eyes of man that is their strong protection. He who dimmed their sight, gave them another boon in place of it; and when He wills, who can resist the power? On questioning this poor blind woman, I found she lived but a little way from where I met her. She said she knew the roads just about her home so well, that she could venture short distances alone, "and I always find one or another, ma'am, to help me along when I want to go farther; every body is very kind to me." She had, on this occasion, met "One" to help her, for, had she gone a little farther, she would have come to a plank thrown across a stream, which might have caused a fall. But it was ordered otherwise, and I took her safely home. On entering the cottage, a boy about six years old, or, perhaps, more, was seated on a low bench in the corner of an old-fashioned, wide chimney. The poor child was swelled in a most distressing manner with dropsy; and his mother told me the "doctors" had done all they could, but he was no better; he had been so for years, and she believed he would never get well. He sat all day long just as I saw him, his eyes fixed on the ground, seldom moving, never complaining, and not often speaking at all. While I was pitying this poor afflicted child, another bright-eyed creature, younger still, came in with an elder girl. This animated child was deaf and dumb! It was scarcely possible to conceive anything more affecting than this cottage scene! The mother blind; the child almost helpless from bad health; another deaf and dumb! But the mother was so cheerful and contented! so rich in faith! so full of peace and joy, and spiritual consolations, that she seemed, indeed, to be dwelling in a "house not made with hands," and to be fed with meat which the world knows not of. She gave me a sketch of her little history, blessing God continually, as she proceeded, for His abundant mercy to her and hers. She is the mother of eight children, five of whom are living at home. Of these, one boy "keeps himself;" another earns eightpence a-week; and the elder girl receives a loaf and a shilling from the parish, to wait upon her helpless mother and little brother and sister. The father is a steady, sober man, who has worked twenty-seven years for the same farmer, and earns seven shillings a-week, one of which is kept back for rent. They all live upon bread, with a scrape of lard upon it, and sometimes, but very seldom, a morsel of butter. Now and then they can buy a "bit of tea," or coffee, which is the cheapest, and an ounce of coffee lasts them, she said, "a great many times!" With quiet, beautiful thankfulness, the blind woman said they wanted for nothing; sometimes they went without a meal; but she had never been in debt! What they could not pay for they never got; her children never asked for anything more than their mother gave, not even the sick one, "and, bless the Lord," she added, "what a merey that is to me!" The most affecting circumstance of all, is the fact, that the little dumb girl generally leads her mother about! "But," I said, "you are blind, and she is deaf and dumb, how do you ever understand each other?" "When I want to go to the shop, ma'am, I take down the basket, and she knows the meaning, and then brings me safe home again." Can any one of my readers imagine a more touching sight than a blind mother led by a little deaf and dumb child? If they can even read this poor description of it without a throbbing of the heart, they must be less than human beings!

This poor blind creature has lost her sight about two years; but such is her deep, unaffected piety, that she appears as accustomed to her painful affliction as if she had never known what it was to see. It is wonderful what religion does for us; I mean religion of the heart, not that which the world understands. It is one thing to talk; another thing to act; and another thing still to suffer joy-

fully what the will of the Lord appoints. I called one day, and found her suffering from illness. She was sitting without a fire, in a cloak and bonnet, and looking very ill; but her heart-happiness was the same. "I want for nothing, ma'am, bless the Lord. I am not drowthy, and I am not hungry; I want for nothing." Oh! how fully did this show forth the faithfulness of the promise, "he that cometh to me shall never hunger, and he that believeth on me shall never thirst." It is impossible to look in her face, sightless as she is, and not see the evidence of a "peace which passeth all understanding;" and the quiet, simple expression of her feelings is exquisite to hear. Here is no excessive "talk of the lips;" no display to catch the eye and deceive; you feel it is real, and it goes to the heart at once.

The cottage is not one to gratify a tasteful imagination; it is situated in rather a wild but pretty spot,—a sort of green, through which passes a cartway; but the scenery on all sides is lovely, and the neighbouring hills always give a sort of grandeur to the valley at their feet. The inside of the dwelling is not attractive either; the air of the little kitchen is not clean or comfortable, as one would wish to see; but a child of ten or twelve cannot be expected to do exactly as she ought, unless innately clean, which few children are; and the poor blind mother can do little. Still they are better than very many others, and their clothes are neat and mended.

Let us all lay to our hearts the lesson taught us by this cottage scene. Let us look round upon our mercies, our food, our raiment, our possessions. Let us consider our health, our eyesight, the sense of hearing, the power of speech; let us dwell a few moments upon all these things, and then ask ourselves whether we can say as the blind mother does, "I want for nothing."

What is the secret of her abundance? What fills her basket and her store? She quietly makes answer, "The Lord is my shepherd: I shall not want;" "Thou preparest a table before me in the presence of mine enemies: thou anointed my head with oil: my cup runneth over." This is the secret, ever-flowing spring of her peace and plenty. She has *nothing*, and yet she "possesseth all things." This is the secret of *all* peace. We may have plenty in the world; but we cannot have peace *out of Christ*. We may turn and twist the matter a thousand ways, but we shall never get at it, never obtain real peace, until we are "one with Christ," until we can experience, in all its truth and richness, that glorious prerogative, "The Lord is my shepherd." Then we shall be sweetly led to say with the poor blind woman, "I want for nothing."

VISITS TO SOME OF THE CHIEF POULTRY YARDS OF ENGLAND.—No. 3.

(PENZANCE).

[The following has appeared in the *Cornish Telegraph*, but was obligingly communicated to us by the author.]

PENZANCE contains several collections of poultry, which would do credit to places where their several merits have long been subjects of emulation.

Among those whose ardour has been specially kindled in this pursuit is Mr. A. Blee; and the result of his observation at Birmingham leads him to regard the Cochinchina race as those most deserving of his care. It would be difficult, indeed, to point out any better lot of pullets than those he now possesses, excellent both as to colour as well as figure. As regards the former, they are mostly fawn and light buff; the neck-hackles in some cases being slightly pencilled, and the legs of all feathered throughout with the same tint. In shape they are robust and compact, with a fine head, and well-proportioned legs. A pullet hatched February 27th in the present year weighed 7lbs. 2oz., and many others were above 6lbs.

Mr. Blee's enclosure is divided only by slight wire net three feet high, which proves that the Cochinchinas have one great merit, viz., that of being retained within bounds by fences which would be altogether disregarded by other fowls. Opposite to this goodly bevy, and in full view, appear the cockerels and their sires, the two latter being admirable

specimens, the one bred by Mr. Sturgeon, and the other by Dr. Gwynn; of blood, therefore, as pure as any fancier can desire. The birds of the year would warrant expectations of their attaining even greater size than their parents; for while the cocks, which are about 16 months old, weigh each 10½ lbs., a young cockerel hatched in February last had already reached 8½ lbs.

Some prettily marked golden spangled Polands, with capital tufts, and fortunately, as we think, *unbearded*, make an agreeable contrast to the lighter colours of the Cochinchinas.

Mr. Blee has given great attention to the original selection and subsequent management of his stock, which promises, however, amply to repay all his care. The following list of the respective weights of some of his Cochinchinas, cockerels and pullets, hatched on February 27th, in the present year, and others in March, speaks favourably for their early maturity.

COCKERELS.		lbs.	oz.
No. 1	8	3
" 2	8	0
" 3	8	4
" 4	8	8
PULLETS.		lbs.	oz.
" 1	5	12
" 2	5	8
" 3	6	4
" 4	7	2
" 5	6	4
" 6	7	12
" 7	7	0
" 8	6	12

A hen of last year was now taken off her nest, and put into the scales, which gave 7lbs. as her weight. At Christmas last she was well up to 9lbs., and this would probably be about an average loss after laying any considerable number of eggs and then sitting.

A singular instance of the good qualities of the Cochinchinas as layers occurred in the case of a Punhard hen, sold by Mr. Blee to a gentleman at Illoggan. Having reached her new home, she laid the next day, and continued to do so, till in ninety-six days she had laid ninety-five eggs; in twenty more days she laid ten more eggs, making in all 105 eggs in 126 days. She then took her nest, sat well, and reared a large and healthy brood.

About 100 head of poultry at present form Mr. Blee's collection, and this is in course of almost daily reduction, from a general desire of amateurs and others to avail themselves of so good a stock. They are certainly well cared for, a four-roomed cottage, with commodious lofts attached, being devoted to their accommodation, with a large exercising area railed off for them in an adjoining field.

Mr. Blee gives it as his decided opinion that, in proportion to their weight, the Cochinchinas are not larger consumers of food than other fowls.

Mr. Lawrence was another of the early members of the Penzance Society, and resolving to decide for himself on the competing claims to excellence of different varieties, he is now enabled to decide on their several merits from personal experience. His Cochinchinas came from the stock of Mr. Andrews, of Dorchester, a most successful exhibitor. The parent birds are certainly worthy of their origin, but their progeny we think bid fair to surpass them.

WEIGHTS AND MEASUREMENTS.—COCHIN-CHINAS.

		lbs.	oz.
No. 1.	Cockerel, hatched March 28th	8	0
" 2.	Ditto, hatched April 8th	7	8
" 3.	Light Cockerel, hatched March 28th	9	8
" 4.	Pullet, hatched April 8th	6	8
" 5.	Hen	8	2

Somewhat more compact in form than the larger varieties, Mr. Lawrence's older birds are distinguished by great symmetry, and a more prevailing tint of cinnamon in their plumage; but the chickens from them have given colours as light as could be desired. It is a curious circumstance respecting Cochinchinas, that the offspring of a dark cock and light hen, or *vice versa*, constantly produce colours as light, or even *lighter*, than when the parents are both of them light-coloured birds.

Mr. Lawrence is fortunate in the possession of a run for his birds in a walled garden near the Roman Catholic Chapel, in addition to his poultry-yard at home. But other claimants now demand our attention, and with good cause. Some *Spanish* are before us with the perfect white cheek, so characteristic of their breed, and the graceful carriage so peculiarly their own. Their character, in an economical point of view, standing so high, no wonder they come into competition with Cochin-Chinas and other favoured races. But, meritorious as are the specimens it now contains, Mr. Lawrence's poultry-yard, we are given to understand, is about to receive a valuable addition in this class from the hitherto unrivalled stock of Capt. Hornby, R.N. We wish him success with them, such as his past efforts have undeniably merited.

But our catalogue of Mr. Lawrence's poultry-yard is yet far from completed. Here are *speckled Dorkings*, as good as we need desire; and the Malays, which although first-class birds, must, we fear, share the fate of their race by gradually yielding to the greater merits of their oriental neighbours, the Cochin-Chinas. Here also are specimens of the birds that excited our admiration at Truro—the *White Indian Game* fowls, the beauty of whose form we cannot but admire, though altogether ignorant as to their possession of the courage of their English relatives.

The meaning of the word "*pencilling*," so often used in describing poultry, cannot be better illustrated than by referring to a pair of *silver pheasants* belonging to Mr. Lawrence. With a touch more delicate than the finest camel's hair brush is equal to, is each single plume of its feathers marked—clear and distinct as the choicest specimen of the florist's most cherished bloom. Thus gloriously clothed, its crest of crimson velvet, confirms our belief that of all the feathered race none can boast of greater symmetry of form, or a more striking combination of colours in its apparel. In courage, also, it takes no second place to the game fowl itself, and thus strict seclusion becomes necessary where more than one male of these birds are kept in aviaries however extensive.

Mr. Lawrence's stock, like some of his neighbours, has of late rapidly decreased, so many, both of this neighbourhood and elsewhere, being desirous of possessing stock selected with so much judgment. To those who think favourably of Cochin-Chinas, it is satisfactory to hear that the experienced owner of so many varieties of fowls has it in contemplation henceforward to limit his attention to Cochin-Chinas and Spanish; and wherever facilities exist for keeping them distinct, his example is, doubtless, worthy of imitation.

Mr. W. C. Pennington also has a portion of this garden, where we saw some good Spanish and grey Dorkings, principally, we believe, from the stock of Mr. Lawrence. These, though as yet young, may still do much before Christmas next, and heartily do we wish success to Mr. Pennington, who, from the first formation of the Penzance Society, has given it his best assistance in every way. His pen of *golden pheasants* at our last exhibition will long be remembered, and most deservedly were they then distinguished by a medal. Mr. Pennington had also purchased some of the best specimens of *Malays* that were shown at Birmingham, but an unfortunate catastrophe occurred, and they are no longer in existence. An aviary of bright-plumaged canaries shows that Mr. Pennington's partiality for the objects of natural history is not limited to poultry alone.

We are all aware of the indefatigable zeal and industry by which so perfect a collection of *British* birds has been formed by Mr. Rodd. The peculiar character of our district has probably afforded greater facilities for such a work than any other part of England would have given, and the Scilly Islands have also contributed many rare specimens. But, however interesting a task to enumerate the various treasures that have been here accumulated, our present task is with the living, for Mr. Rodd's patronage has been shared by them as well as by the fortunate occupants of his glass cases. Some white Dorkings, which, passing into other hands, won a first prize at the Penzance Exhibition, were the first inhabitants of his poultry-yard, but their plumage was better suited to a rural than a town abode; they were therefore succeeded by grey Dorkings, birds that fully bore out the reputation of Mr. Baily, the

dealer from whom they were obtained. Mr. Rodd is also in possession of some very handsome game fowls, whose martial carriage is, probably, a true criterion of the courage they would manifest were the barbarisms of other days ever likely to be renewed. The Penzance Poultry Society has been greatly indebted to this gentleman for the continued assistance which, as Secretary, he has always bestowed upon it.

(To be continued.)

W.

SUFFOLK HEATHS.

I CAN scarcely conceive a greater treat for the lover of nature than a ride or walk over one of our Suffolk Heaths in the month of June, when the Furze or Whin is in full blossom. These heaths extend along the coast, with slight interruptions, from near my residence for upwards of thirty miles. In some places, as far as the eye can reach, scarcely is anything to be seen but Whins with their yellow flowers waving like a sea of gold. They vary in height from two to eight feet; and a person no sooner enters amongst them, than he is struck with the beauty and variety of their fantastic forms. There is hardly any ornament or order in architecture which cannot be recognized; domes, columns, pyramids, broken arches, &c., all gilded, appear to be scattered around, like the ruins of some ancient city. There is one narrow gorge in particular, about a-mile-and-a-half in length, and where no two persons can well pass, up which I often ride, literally buried in flowers, the sprays being above my head. Their perfume is that of the cocoa-nut. These wild and beautiful places were much resorted to formerly by smugglers, who there secreted their booty. If a run of spirits or tobacco was landed and found its way into these heaths all chance of discovery vanished. "There were three gangs of smugglers here," said an old shepherd to me the other day; "I knew all the fellows well; and often have I driven my flock of sheep to and fro in the early morning over the wheel-marks of the previous night to obliterate their traces, and my reward for this service was a bottle of brandy." Smuggling is not so much carried on now.

Whins are largely used for fuel, fencing, and draining. The parishioners in our parish have a right to cut Whins at pleasure; and the farmers who reside near the heaths have the liberty of using them by virtue of their occupations. The latter employ a labourer, to whom they give 1s. per load of forty faggots for cutting and binding; the load sells for 3s. on the spot to the carters, who retail them round the neighbourhood at 4s. a load. Fires sometimes occur on the heaths, and then the church-bell is rung, and all who can repair to the spot provided with various missiles to extinguish it; when this is accomplished, men are left to watch, for the smothered flame will often break out afresh and run in different directions. Acres of Whins are by this means sometimes consumed, and a bright greensward springs up in their place. Notwithstanding their great annual consumption, Whins are still on the increase.

There are two sorts with us, the *Ulex Europæus*, which blossoms in the months of May, June, and July; and the *Ulex nana*, or Dwarf Furze, which blossoms in September, October, and November. Between these periods, the purple *Ericas*, or Heaths, come into flower, and form, with the Hawkweeds and Harebells, an interesting link in the floral chain. Thus Nature, on the wild heaths, crowns barrenness with beauty. Among the *Ericas* grow the *Ferns*, and both together cover large tracts; they are principally used as litter for farm-yards and cattle-sheds, and tread down into excellent manure. Partridges nestle in the *Ferns*, hatching there their young broods; and for this reason they are mostly preserved. *Lichens* and *Mosses* furnish a varied and elastic carpet. Crabbe, of whom Byron has said that he was "Nature's sternest painter, but the best," has given us in his Poems many faithful pictures of our Suffolk coast; he writes:—

"I loved to walk where none had walked before,
About the rocks that ran along the shore;
Or far beyond the sight of men to stray,
And take my pleasure when I lost my way;
For then 't was mine to trace the hilly heath,
And all the mossy moor that lies beneath:
Here had I favourite stations, where I stood
And heard the murmurs of the ocean-flood,

With not a sound beside, except when flew
Aloft the Lapwing, or the gray curlew,
Who with wild notes my fancied power defied,
And mocked the dreams of solitary pride."

The farms on the outskirts of the heaths have mostly a right of pasturage attached to them, and their occupiers are generally flock-masters, and keep from five to twenty and more score of sheep. It is a beautiful sight to see these flocks approach their feeding-grounds from different points, and separate into lines among the furze bushes, looking at a distance like so many net-works of silver. A shepherd and dog attends each. The latter is shaggy, large, and docile, very useful in keeping the flock apart, very expert in singling out intruders, and he will collect the sheep together, and follow his master wherever he may incline to lead them.

Shepherds themselves are generally morose and taciturn, they are also long-sighted, as is the case with sailors, and most persons accustomed to view distant objects. I remember, a few years since, when some North American Indians were on a visit at Plashet House, the residence of the late Elizabeth Fry, of Upton, they descried minutely objects in the rigging of the vessels passing up and down the Thames, when no other persons present could discern them, and it was not till a telescope had been procured that the facts could be verified.

Hares are not numerous, but rabbits abound, and do much damage to the crops of the farmer; indeed, so rapid is their increase, that it is necessary to have occasional battues to destroy them. They usually sell from 1s. to 1s. 2d. per couple. A pair of these in "a ship-pie" is a welcome treat after a walk on a frosty morning. By virtue of the game laws, game is preserved on our heaths, greatly to the annoyance of the public, to the injury of the agriculturist, and to the demoralisation of the labouring classes. Hawks are often shot or entrapped by the game-keepers. Rooks and starlings frequent in flocks the more open tracts, to feed on worms, insects, and larvæ; they mix with the sheep, probably because the tread of the latter disturbs what they are searching for; but should a crow make his appearance, the shepherd becomes alarmed, as he thinks that this bird portends death or disease among his flock; certain it is that during the lambing season, he is sure to be hovering about. Lapwings congregate in numbers, but a single pair will often separate from the rest to hatch their young at a distance, and should a stranger approach their haunt they will sail around him, and greet him with their wild cries. Plovers, redwings, and fieldfares, are to be met with. The fern-owl or goat-sucker, frequents the hedge-rows; cuckoos, in the spring, are calling to each other throughout the day, and larks are abundant, often damaging the young corn by drawing up the blades and feeding on the sprouted kernels. There is no lack of the smaller birds, as stonechats, whinchats, yellowhammers, greater and lesser redpoles, greenfinches, goldfinches, &c. Our village boys capture these by means of a bird-lime which they make by chewing the bark of the holly-tree.

The configuration of our heaths is undulating; the soil, sand and gravel; and there are abundant evidences of their having once formed the bed of the ocean. The history of the gravel is a desideratum. Its colour, for the most part, is red, and abounding with flints, which are small and rounded, showing them to have been waterworn. Where in the world so many flints could have come from, is a puzzle yet to be solved; certainly not from the beds of chalk in our neighbourhood, for these are free from them. The belief that they were originally marine vegetables seems probable, not only from their exterior form, but also from their interior structure—numbers, if broken, display the stem, branches, and organised parts of plants in great perfection, and sometimes the plant itself will separate entire from its matrix. A diligent and scientific investigator might soon collect a series of these fossil plants, and perhaps be able to name and classify them. And if to the study of these he would add that of the various rounded fragments of rocks, and could decide on their original habitat, he would go far to establish the laws of tides and currents. The veins and markings in many of the red flints, prove that the colouring-matter must have entered them when they were in a pulpy state; these flints, if polished, often vie in beauty with more costly gems. The sifting of stones from

the gravel is the work of our unemployed poor; and the materials thus raised are used for the repair of the public roads. Gryphites, echinites, belemnites, madrepores, coals, &c., are found in the gravel. The sands vary in colour and texture. Bog-earth is found in the water-courses and round the margins of ponds; and the most interesting, if not the most useful strata of all, is the crag, which lies under the gravels, at various depths, being of different thicknesses, and often cropping out on the surface. This is a shell deposit, formed, apparently, at two distinct periods, and consists of the upper, or red crag, and the lower, or coralline crag. On entering a crag-pit (which is generally formed by cutting down a foot of a hill) you have before you a perpendicular wall from ten to fifteen feet high, bristling all over with the projecting points of shells; and here an Owen, or an Agassiz, might dive and delve to his heart's content. It furnishes amusement for the visitor, specimens for the collector, and matter for the scientific inquirer. About four hundred species and varieties of these fossil shells have been already discovered. My own collection consists of about that number, besides a great variety of other organic remains, as corals, zoophytes, foraminifera, teeth, &c., all of marine origin. The shells vary in size from a pin's-head to that of a pony's hoof; and the teeth, from a barleycorn to that of a man's hand. In addition to these, there are occasionally to be met with the teeth of the elephant, rhinoceros, and bear; and it is a curious fact, that out of every hundred of the marine fossils, sixty of them are now extinct, or their representatives are to be found only in tropical seas. The corals must have been produced under a like temperature; thus proving that, at the time of their formation, a totally different order of things prevailed. What secrets, then, does this single drawer in the geological cabinet unfold to us? It is a page in nature, written in physical characters on the earth's changes, itself not being obliterated by time. A careful investigation of these phenomena, and a comparison of extinct with living species, would serve to correct theory, and enlarge the bounds of our scientific knowledge.

S. P., *Rushmere.*

SPANISH *v.* SHANGHAE FOWLS AND GOLDEN PHEASANTS.

THOUGH my experience did not lead me to the conclusion to which you had arrived, viz., "That two or three fowls by themselves will consume proportionately more food in a day than when a great number are fed together;" yet, "as fair play is a jewel," and as you considered this an objection to the fairness of my trial, I have lost no time in putting the things to the test, and the results which I now enclose you, prove that your's is theory and nothing more. You will see, that in confinement the fowls eat rather less than when with a free range; and I think this is natural enough, as in confinement they are not as healthy as when they are able to find insects, and grasses, which they know assist digestion, and promote health. The Gold Pheasants were in the moult, and did not lay.

As for your second objection, I certainly did not weigh all mine, nor can I send you the weights of the "full grown" fowls, but I know that the weight of the Spanish Cockerels I quoted, varied from 5lb. 14oz. to 6lb. 3oz.; with the Pullets just under 5lbs., which even, with the argument lately adopted "in proportion to size," will give a greater weight than that of the fowls on which your trials were made, the average weight of which, I find to have been 3lbs. 9oz. Many of your's must, therefore, be *mere chickens*, at least according to the weight of my Spanish chickens.

I cannot end this discussion better than by quoting a letter from a friend of mine (a man of strict veracity), written from Devonshire, where the fowls do not probably enjoy the over "keen appetites bestowed upon their brethren in the north," relative to a Cochinchina Cockerel, hatched March 3rd; and mind, this is the opinion of a former C. China fancier.

"Fine fellow as he is, however, he certainly does eat enormously. One day I weighed his food, which was chiefly barley-meal mixed with milk and water, of which he

ate in one day about $1\frac{1}{2}$ lb., or to about the value of $1\frac{1}{4}$ d., which I think quite enough "in proportion to size."

I give you these facts; I think they require no comments.

GALLUS.

TRIAL OF COST OF SPANISH AND GOLD PHEASANT FOWLS.

Time of Experiment—Oct. 28 to Nov. 4.

Lots	Description	Age	Weight Oct. 28	Weight Nov. 4	Quantity of food consumed		Cost	Weekly average	No. of eggs	Weight of eggs
					lb. oz.	d.				
1	Gold Pheasant Cock	1851	Not weighed.	Not weighed.	Corn	3 0	3	1½		
	Gold Pheasant Hen	1851			Meal	13	1			
	Gold Pheasant Hen	1851			Bran	1 0	4			
					4 13	4½				
2	Spanish Cock	1850	Not weighed.	Not weighed.	Corn	3 8	3½	1½	6	18½
	Spanish Hen	1851			Meal	1 3	1½			
	Spanish Hen	1851			Bran	1 0	8			
					5 11	5½				

[We are glad that "Gallus" has settled the question, that a few poultry do not eat more in proportion than when many are fed together, because, though our limited experience on this point seemed to indicate the contrary, yet we have never tried the experiment so accurately as has been done by our correspondent. He has proved also, by his experiments, that a Spanish Cockerel, weighing on an average 6lbs, and two Spanish Pullets, weighing rather less than 5lbs. a-piece, can be kept for seven or eight farthings per week each; whilst a Shanghae Cock, weighing 10lbs., and two hens, weighing 7lbs. (we speak within their actual weight), cost each from fourteen to fifteen farthings. We should not be far out, we believe, if we stated that the experiments of "Gallus" demonstrate that Spanish fowls, weighing half as much as Shanghae fowls, only eat half as much food, whilst they lay as many eggs, and one-third larger. Those, therefore, who look to eggs only, will do well to keep Spanish fowls. Those who are limited in the space they can devote to Poultry; those who must have birds that cannot fly over a low fence; those who wish for eggs during the winter, and for chickens for the table when only twelve weeks old, and for full-grown fowls that will fill a dish like a turkey; those who admire gentleness of habit, elegance of form, and beauty of colour; and who would have no objection, as did Mr. Sturgeon, to sell 172 birds for £608, will keep Shanghaes. The result of that sale gives the verdict of the public without requiring a jury to be impanelled.—Ed. C. G.]

THE BEST FUCHSIAS.

ALLOW me to recommend a few of the best Fuchsias to the notice of your readers, and in doing so I would state what I consider the properties of a good Fuchsia.

First, the *tube* should be stout, and in due proportion to the breadth and length of the *sepals*, which should be broad, retaining their breadth for at least half the length, well reflexed, but not turning round like a ram's-horn, but standing boldly out, and the tip turning up with a gentle curve; the *corolla* should expand well, so as to form a bell-shape, and be quite even on the edge.

The following varieties, taking all points, come nearer that standard than any others I know. For *dark varieties* take *Nil Desperandum*, *Champion of England*, *Mayle's Game Boy*, and *Turner's Standard*; these, if well managed, are not to be beaten by anything yet out. For *light varieties*, *Bank's Expansion* and *Princess*, and *Kendal's Beauty Supreme*. I know of no Fuchsia, light or dark, having a tube or corolla to equal this. It is rather bad to manage, it requires a light soil, not much manure, and a little heat to bring the sepals up. *Mayle's Bride* also requires a light soil. *Mayle's Diadem of Flora* is a fine greenhouse flower, but rather too coarse for exhibition purposes; every cottage gardener should grow it. Mr. Harrison, of Darlington, has a first-rate light one called *England's Glory*, if cut blooms form any criterion, and I think they are, any one may purchase this without fear of being disappointed.

Any one who may purchase the above-named, and grow them well, will not regret the advice given by

A LANCASHIRE FUCHSIA GROWER.

BRITISH SONG BIRDS.



THE TITLARK, OR TREE PIPIT.

INSESSORES DENTIROSTRES. ANTHIDÆ.

Alauda trivialis, Pipit Lark; *Alauda minor*, Tree Pipit; *Anthus minor*, Field Titling; *Anthus arboreus*, Tree Pipit; the Titlark.

THE Tree Pipit appears to be not so generally known as to be readily distinguished by unpractised eyes from its congener, the Meadow Pipit, while the two are often confounded with each other, each being called the Titlark. The Tree Pipit, however, which is the true Titlark (that is, if you were to request a bird-catcher to send you a Titlark, he would, on receiving such order, send the Tree Pipit), is a summer visitor, one of our migratory birds, arriving here about the first fortnight in April, and is instantly known by its constant, never varying, but cheerful song, which it commences immediately on its arrival. It is usual to observe it perched on the topmost branch of the highest trees, when every few minutes it uprises into the air some distance, uttering a pretty twittering note till it arrives at a certain height, then, with outspread wings and tail, it gradually descends singing its strain, as much like those of a canary as it is possible for one bird to sing like that of another; this in a few minutes is repeated, in like manner ascending and descending, and by a careful observer may be noticed every five minutes, or even more frequently. Now, the bird with which it is often confounded seldom or never perches on trees, and as for its song, I can say very little in its favour. It may be distinguished from the Meadow Pipit, also, first from its being of a lighter colour in its plumage, not so green a cast; next, in being a larger bird; and, lastly, from its hind claw being shorter, and for that reason better enabled to grasp the branch on which it perches. Its gait, too, is more stately than the Meadow Pipit, it walks along the grass more slowly, and moves its tail in a similar manner to the Wagtails, while it differs from the Larks in being a *washer*, and not a *duster*; though in washing itself, it does not perform this operation so vigorously as other birds, but cautiously sprinkles itself with the water. In its habits it is solitary, only to be seen in pairs.

In its natural or wild state, the food of the Titlark mainly consists of insects, such as beetles, grasshoppers, flies, and their larva, and worms. It may be readily and easily kept in confinement. I have, however, never attempted to keep a wild caught bird, as I so much prefer to bring them up from the nest, they then become exceedingly tame and familiar, feeding from the hand most readily and pleasingly. The food upon which I bring them up is bread and milk boiled together, and formed into a stiff paste, with which some coarsely powdered hempseed has been well mixed; chopped egg, white and yolk together, and crumb of bread mixed together or separate, and when able to feed themselves, they usually partook of the food common to all. If placed in an open aviary their habits are well developed, and they may be seen singing on the topmost branch of a tree or perch, and occasionally from thence catching insects on the wing. Its nest may generally be found on the ground, always well concealed, and formed of such materials as best corresponds with the spot selected, but is usually composed of dried grasses and fibrous roots, lined with similar materials of a finer quality, and mixed with hair. The female is a close sitter, and is not readily frightened from her home; but if

she once catches sight of your eye watching her, she stealthily and quietly creeps off her nest, and running along the ground some distance, at length takes to flight. The male bird is usually singing on a tree very close to the nest, which I have often discovered by observing the male bird, after singing, descend to visit his mate. They will breed in confinement, which has been the case with me; this I attribute to my having brought the birds up by hand.—
WILLIAM RAYNER.

DISEASES OF POULTRY.—LAYING SOFT EGGS.

SOME time since I noticed in your paper a request for any information respecting the Diseases of Poultry, and their treatment. For some years I have relinquished the use of the lancet for that of the pen, but when opportunity offers I employ my medical experience (now getting somewhat rusty for want of use) in alleviating the disorders of my domestic pets. I need scarcely say, that all empirical remedies, such as Rue-pills, &c., &c., meet with no encouragement from me; but that I endeavour to treat any disease on ordinary general principles. My medical experience with regard to Poultry is rather limited, my stock consisting of the progeny of two hens, and a cock of Baily's grey Dorkings, which I have found to be as hardy and healthy as it is possible for fowls to be; I have not lost this year a single chicken, although some of the breeders of Cochins in the immediate neighbourhood lost scores of their birds. The only disorder that I had to treat was the laying of soft and partly-formed eggs, which occurred in one Dorking hen, and in a half-bred Cochin. It appears to me that the laying of soft eggs must arise from one of two causes; either a deficiency of lime rubbish, or old mortar, for the fowls to peck at, which was not my case; or from an excited or inflamed state of the oviduct. Thus a hen escaping into the street, and being driven, will often lay a soft egg or two. The Dorking hen above alluded to began to lay exactly one month after hatching, and laid very large eggs, some weighing more than 3½ oz.; she then laid several soft eggs when at roost, and others of which the skins were not closed; the feathers over the back were raised; there was great effort made to get rid of the imperfect eggs and general feverishness; all the symptoms betokened inflammation of the egg-passages, and the treatment was evident. I employed the same remedies that would be used to subdue inflammation of the mucous membranes in the human subject,—one grain of Calomel, and one-twelfth of a grain of Tartar emetic, were made into a pill with bread-crumbs, and readily taken. The next day no egg was laid; but on the following day a well-formed hard-shelled egg. Some weeks or months after the complaint recurred, was met by the same treatment, and a hard egg was again laid on the second day. The half-bred Cochin hen was treated in the same way, and with precisely the same result.

There ends my poultry medical experience. Should I at any time have any extension of practice, or any *post mortems*, I will, if you think my notes worth inserting, send you the result.

As I have the pen in hand, I may perhaps be allowed to give you *my* opinion respecting the Cochin controversy. As *fancy* birds I admire them; those sold at Baker-street from Mr. Sturgeon's stock were truly magnificent. As table birds, it appears to be very doubtful whether (notwithstanding their great size when full grown) they can be fattened to eight or nine pounds at four or five months, like the Dorkings. Again, their fat and flesh come in the wrong place; their wings are so imperfectly developed that they do not fly; and the muscles which move the wings, and form the mass of flesh on the breast, are slightly developed also. Then, although "*de gustibus non est disputandum*," I doubt very much the delicacy of that palate that prefers a Cochin to a Dorking. As to eggs; the fact that the hens become broody several times during the season must lessen their productiveness below that of the Dutch every-day-layers, who never sit; and it appears to me, that if an equal number and weight of eggs can be obtained from a Cochin and a Hamburg, the latter must be the most profitable; for the larger bird must require a larger amount of food, to

supply the function of nutrition and the production of animal warmth.

Another point, and I will finish this rambling, desultory letter. Will you lend your aid to securing uniformity in the names of the Polish and Hamburg. Baily, in the new edition of his book on Fowls (which, by-the-by, is one of the very best really practical books I have seen), Trotter, Dixon, and Richardson, all agree in terming *all* the top-knots, "Polands," whether they have small combs or not, and they confine the term "Hamburgs" to the Dutch every-day layers and its varieties, which are all without a top knot. If this example is followed, there will be a uniformity of nomenclature, which I was sorry to see one of your recent correspondents endeavoured to overset. It appears to me, that it would add much to your usefulness, if those desirous of exchanging cocks, to prevent breeding in-and-in, were to communicate to you; and, if you permit such a notice, I would say that I should be glad to exchange one or two very promising grey Dorking cockerels for equally good birds, or for either gold or silver-spangled Hamburgs.—W. B. TEGTMEIER, *Tottenham, Middlesex.*

TO CORRESPONDENTS.

* * We request that no one will write to the departmental writers of THE COTTAGE GARDENER. It gives them unjustifiable trouble and expense. All communications should be addressed "*To the Editor of the Cottage Gardener, 2, Amen Corner, Paternoster Row, London.*"

TO ALL CORRESPONDENTS.—In self-defence we are reluctantly compelled to announce that we must decline inserting any announcements of articles to be sold, or required, except as advertisements. We are compelled to adopt this resolution, because we find that a contrary course is misinterpreted, lays us open to the charge of giving preferences, and has led to impositions, not only upon ourselves, but upon our readers. Our resolution is sustained by the following letter, by which we are much obliged:—"Enclosed you have payment for inserting the advertisement herein. Should this not be correct, please let me hear from you. You will, I have no doubt (when I tell you that myself and other gentlemen, your constant readers and well-wishers coincide with me), understand me when I tell you, with the very best intentions and most friendly feeling, that you do not get the support to nearly the extent you would do from gentlemen having a few "spare Cochin-Chinas," &c., to dispose of—(a numerous body now)—in consequence of allowing any one who writes to you to append to his communications an advertisement of this or that sort of fowl, or a few 'Spanish' to be disposed of, &c. In one case an advertisement appeared in the regular character, and on the same page, three or four communications of this very nature, and each appearing in the very article before put before the public. It has been thought that this favour was only allowed to correspondents who were also subscribers, or well known to the editor. But this is not so; in one case, at least, when fowls were purchased from one of these favoured ones, and the purchaser was most shamefully cheated and imposed upon; whereas, not unlikely, the honest advertiser came off without a sale, and minus the money sent for his more expensive, but less favoured, advertisement. It strikes everyone so clearly that this is not the kind of way an honest advertiser should be treated, that I am sure I have only to name this to secure better treatment in future. In conclusion, I wish you every success, and hope, in future, I shall see 'The Country Gentleman's Companion' increases in circulation, and made a medium for advertising to the extent its editor's most sanguine desires can wish." We now state most distinctly and unreservedly, that when we have allowed such notices to appear, it has only been on some plea which we thought called upon us to sacrifice our own pecuniary interest. In future we must be more firm—for the sake of others as well as of ourselves.

SILK FOWLS (*H. S. B.*).—There may be a variety of these in Cochin China; but they have no relationship to the Shanghai fowl. The Silk fowl is a native of the warmer parts of the East Indies. We never heard of a cross between them and the Shanghai fowls.

PINETUM.—*Ignotus* has the following—*Cupressus stricta*, *C. Gonioides*, *C. macrocarpa*, *C. funebris*, *Araucaria imbricata*, *Juniperus communis*, *J. Chinensis*, *J. excelsa*, a deciduous *Cypress*, *Cedar of Lebanon*, *Pinus excelsa*, *P. insignis*, *Cryptomeria Japonica*, *Taxodium sempervirens*, *Abies Canadensis*, *A. Douglasii*, *A. Menziesii*, and wants a few more of the *Abies* tribe, or other *fastigiata* evergreens. A few more desirable additions to your list are—*Abies morinda*, alias *Smithiana*, or *Khutrow*, for the three are the same. Then the Silver-fir tribe, or *Picea*, as *P. Cephalonica*, *P. Fraseri*, *P. Webbiana*, and *P. Pinsappo*. The old Silver-fir is as handsome as any; and, where the soil suits it, the Balm-of-Gilead-fir, or *P. balsamea*, the same. *Pinus pinea*, or Stone-pine, *P. Sabiniensis*, and *P. Lambertiana*; *Cupressus torulosa* and *C. Uhdiana*; and of the very newest, if you can spare a guinea for it, *Fitzroya Patagonica*—a fast-growing and beautiful tree, after the manner of the *Cypress*. Of *Junipers*, plant *oxycedrus* and *thurifera*. The Virginian *Cedar* (*Juniperus Virginiana*), and Chinese *Arbor vite*, are not in your list; neither are the *Deodar* and *Mount Atlas Cedars*, all of which should be in every selection of the order.

HINTS AND ANNUALS (*S. S.*).—We quite agree with you that it would be desirable to have monthly lists of Annuals and other things

that might be sown in heat or cold, and now that we have more room we shall keep your "hints" in mind. Nothing of this sort, however, will be in season before the middle of next February. Meantime we should like to hear of any other "hints" which our subscribers think would improve our pages. One of our chief recommendations has been to fill all the spare places between bedders as soon as the beds are planted; but whether "one sort, or colour, should be planted in each bed" is a matter of taste with which we never interfere. We prefer three colours in some of the beds, two in others, and one only in the greatest number. At other times, the stock of Annuals governs our choice; the truth is, we can hardly do amiss if the soil is all covered as soon as possible. It is out of our power to say at what distance bedding-plants should be planted, for each kind cannot be persuaded to be of the same size all over the kingdom at the time of planting. We have planted *Verbena* at six inches apart; *Calceolarias* and *Petunias* the same; *Geraniums* from nine inches to a foot from plant to plant, and so on; but all these we have put in at twice or three times such distances. The *Kilkenny Anemones* are the same as the common border ones all over the kingdom.

BACK GARDENS (Grumbler).—Mr. Robson will tell you how to make the best of the back garden, 200 feet long and from 35 to 40 feet wide. We shall also give a plan or two to convert such enclosures into flower-gardens; still we have no sympathy with "grumblers."

CATERPILLARS ON HAMBURGH GRAPES (C. W.).—"The Caterpillar which feeds on the outer skins of the berries of Grapes is that of the little moth *Cochylis Amphaciella* of Andouin's 'Memoir on the Insects of the Vine.' Fumigation and a sharp look out seem to be the only serviceable remedies."—J. O. W.

OXALIS BOWENI (M. D. P.).—We suspect the dull weather has lately been against the flowers expanding. Give it the openest and lightest position you can command, and a temperature little below 50° at night. See an article to-day by Mr. Fish.

POULTRY-KEEPING.—A *Poor Man's Well-wisher* writes thus:—"When will this question be set at rest concerning which is the most profitable breed of poultry for a poor man? I cannot wait any longer, for have a pair of some sort I must; for what I have read about them in THE COTTAGE GARDENER has put me so much agog for some of these fine birds, that I can hardly sleep in my bed for thinking about them. What profitable things they must be to live upon little more than a penny per week, and to lay six eggs in a week that are worth one shilling each! O dear me! but I must have some of them, you may depend upon it. If I was not a poor man, there would be Cochins-Chinas, Dorkings, Spanish, and Malays, to be seen at my house in less than a month; but, as it is, I am hardly able to purchase one pair, and this makes me so desirous of knowing which would be the best; but I think I may make myself quite satisfied that there is no one going to tell me, so I must purchase one pair at a time, and prove for myself. I think I shall commence with the Cochins-Chinas, for I have a friend that has reared five this summer, two cockerels and three pullets. They were hatched the last week in May, and he tells me that the five have not cost him twopenny per week; and I am sure they have not been within half-a-mile of a stack-yard, or a barn-door, neither have they seen a field of grain of any sort. What will Mr. "Gallus" say to this? They have a good walk on grass, and they are now living, and have been for this last month, upon acorns, which they pick themselves; and when they come home at night they would not thank you for a bit of barley, although Mr. "Gallus" says they are never satisfied. Now all this I know; but about Dorkings, Spanish, and Malays I know nothing; but I don't care how soon I do, for I long to be in possession of some of these profitable birds. But my wife is quite angry to think about me giving a guinea for a pair of fowls, when I have to work hard all the week for the one-half of it; for I must inform you that I am nothing but a poor day labourer, and gold is a thing that I see but once a fortnight; and besides, I shall have to pay for every grain that they eat, for I have nowhere to turn them out, neither on grass nor gravel; but it is no use, for this whim has got hold of me so fast that I must have some of them. But woe-betide you, Mr. Editor, and Mrs. Anster Bonn, if I do not find some little truth in your writing, for I know my wife will comb my hair for me if I do not get some little profit, after spending so much money. So now I hope, instead of telling me which is the best sort to keep, you will tell me which is the best and cheapest way of feeding them, and tell your readers to follow my plan, and get a pair of each sort, keep them separate, and judge for themselves which they think are the most profitable; or, if they do not like to venture into quite so deep a water that I am venturing into, why all that I can say is, there is a good time a coming, so they must wait a little longer till I am got safe ashore, and then I will tell them exactly the way that I got over, if ever I do get over at all, and if I sink I will hold up my hand; but the worst of it will be to them, if there is sound land on the other side, I shall be a mile-and-a-half ahead of them, for you may depend upon it if they waited to see me safe over I shall not wait for them afterwards, for I shall be boldly on the road, for I know very well that there will be poultry shows in our country shortly, where prizes will be given for the best breeds of poultry, and then how I shall laugh at them if, the whilst they are dabbling in the matter, I am in the field gaining the prize. But I must stop, for I dare say you will not think this lot of stuff worth a place in THE COTTAGE GARDENER; but, Sir, I hope you will encourage your cottage readers to press forward. I will tell them anything that I know with the greatest of pleasure, if they would like to hear it, and you have no objections against printing it; there is always something to be learned of the ignorant."—A POOR MAN'S WELL-WISHER. [We shall readily insert more of your "ignorance."—ED. C. G.]

MASTERS AND THEIR GARDENERS.—We well knew when we inserted "A City Friar's" letter, that he had run his pen into a hornet's nest. We have received many replies, but can find space but for one, and with this the discussion must cease:—"I hope you will pardon the liberty I have taken in writing a few lines to you on the subject of a gentleman's letter, who styles himself 'A City Friar,' in your number of October 14. He considers gardeners as 'droll dogs,' and as having the bump of conceit. Now, it is all very well for the masters, such as 'The City Friar,' to be

talking like that; but what would be the consequence if they were to listen to all that is told them? They would be led astray and blamed for carelessness, or for want of a little more of 'the bump of conceit.' If a master wishes to be as master, let him be one, and let the gardener be a gardener; or, else let the master have a common labourer, and himself may be the head-gardener. There are a class of people who are very conceited—masters as well as servants; but you will not find there gardeners who understand their business. They know what wants doing as well (in my opinion, better) than their masters. There are many things a gardener can see want doing that a master does not see, and it grieves him because he cannot do it; why is this but because there are other things that want doing at the same time? This I know by experience; and my opinion is, that if such masters as these were to allow more strength, and leave the managing to the gardener, their gardens would be kept in better order, and things that the master sees undone would be done, and it would be more to the master's interest as well as the gardener's credit. It makes a man careless when a master comes ordering a thing one way, and, perhaps, that thing ought to be done diametrically another way. They would find it quite a different thing if they could but exchange situations."—A CONSTANT READER.

CELERY (J. R. K.).—Nutt's *Champion* and Cole's *Solid-Stalked* are the best varieties we have grown; but we see that at the last meeting of the Horticultural Society, in Regent-street, *Whittington's Red* carried off the prize. Let us add, however, that Celery is so much influenced by cultivation, that almost every variety can be grown to a very large size and to a high degree of excellence; rapid unchecked growth secures both those good qualities. We cannot name dealers.

OUR VOLUMES (Clericus).—You can have the two half-yearly volumes about bound together in one volume, with the fitting Indexes, by applying at our office. We are enquiring about the seed, and will send it if we succeed; we have none left.

SEWAGE FROM HOUSE AND STABLE (E. C. S., Beccles).—Probably about four buckets of water to one of the liquor will make it sufficiently weak for both fruit-trees and flowers; but this is not the time to apply it to them. Why not give it to *growing* kitchen-garden crops, such as cabbages, celery, &c.

DRAIN FROM STABLE (B. J.).—To convey the drainage from this, the piggery, &c., to a tank, nothing will answer better than the sewer pipes now made of coarse stoneware. If they are not less than six inches diameter they will not be liable to choke, if laid with a moderate slope to the tank. A common cast-iron pump is the best for emptying the tank.

HEATING SMALL CONSERVATORY (E. C.).—As your conservatory does not contain more than twenty-five cubic yards of air, and you only wish to exclude the frost, we should have two four-gallon stone bottles, and if one of these was kept with hot water in it during the day, and both were kept so filled at night in the conservatory, you would effect your purpose. To prevent their appearing unsightly during the day, it is very easy to have a wooden case perforated with holes to put over them.

SHANGHAE FOWLS (A Poultry Fancier).—If you cook the cockerels when three or four months old, accordingly as they have thriven, their legs do not appear awkwardly long when roasted. Nor do they at any time appear too long, in proportion to their size, if true and well-bred specimens are kept. It is a libel to call the gangling, half-Malay creatures, which are so common, by the aristocratic title of "Shanghae."

TRAINING POTS.—Mr. J. H. Horsley justly observes: "I have often thought what an assistance it would be if we could get some pots made with small holes round the rim to pass the matting through, instead of crooks and all other contrivances. I have written to Mr. Phillips, potter, of Weston-super-Mare, who informs me he will get some pots made immediately for the trade; and I am sure Geranium growers, who are desirous of making good specimens, will find those pots very useful."

LOUISE BONNE PEAR.—Mr. Hogg says:—"It is a very old French variety, and originated about the middle of the 17th century, in Poitou, on the property of a lady whose christian name was Louise, but whose surname I have never been able to discover. There is, I believe, no good ground for calling any other variety by the distinctive name of "Bonne;" but the old Louise Bonne, being for upwards of a century and a half a popular variety in France, other varieties received similar appellations, either from fancied resemblance to the old variety, or as recommendation of excellence, merely distinguishing them with the name of the places where they were raised, or whence they came. The Louise Bonne of Jersey is a misnomer, and has no claim to the 'Bonne.'"

NAMES OF PLANTS (Rev. R. M. E.).—You send us such small specimens, that you give us much needless trouble; why not send larger ones? We cannot say, from such a specimen, which of the *Geraniums* your's is. The variegated leaf is of *Phlox suaveolens*, var. *variegata*. The other small leaf is, probably, of *Swainsonia galegifolia*. We really have not time to ponder over such specimens. (W. X. W.).—Yours is not a *Helichrysum*, but *Helianthus altissimus*.

NAMES OF FRUITS (A. B., an Old Subscriber).—The apple is *Dumelow's Seedling*, and the pear is *Easter Beurre*.

LONDON: Printed by HARRY WOOLDRIDGE, Winchester High-street, in the Parish of Saint Mary Kalendar; and Published by WILLIAM SOMERVILLE ORR, at the Office, No. 2, Amen Corner, in the Parish of Christ Church, City of London.—November 18th, 1852.

WEEKLY CALENDAR.

M D	W D	NOV. 25—DEC. 1, 1852.	WEATHER NEAR LONDON IN 1851.				Sun Rises.	Sun Sets.	Moon R. & S.	Moon's Age.	Clock aft. Sun.	Day of Year.
			Barometer.	Thermo.	Wind.	Rain in In.						
25	TH	Michaelmas Term ends.	29.492—29.469	46—23	S.W.	—	38 a. 7	57 a. 3	5 49	14	12 41	330
26	F	Oak leafless.	29.738—29.599	36—28	N.W.	—	39	56	rises.	☺	12 22	331
27	S	Greenfinches flock.	29.899—29.788	42—26	N.W.	—	41	55	4 a 37	16	12 2	332
28	SUN	ADVENT SUNDAY.	30.073—29.990	44—21	N.W.	—	42	55	5 13	17	11 41	333
29	M	Song Thrush again sings.	30.170—30.158	39—22	S.W.	—	44	54	5 59	18	11 20	334
30	TU	ST. ANDREW.	30.247—30.162	39—20	N.E.	—	45	53	6 56	19	10 58	335
1	W	Gray Plover goes.	30.257—30.245	39—32	W.	—	46	53	8 1	20	10 36	336

METEOROLOGY OF THE WEEK.—At Chiswick, from observations during the last twenty-five years, the average highest and lowest temperatures of these days are 47.1° and 35.5° respectively. The greatest heat, 60°, occurred on the 28th in 1828; and the lowest cold, 16°, on the 29th in 1846. During the period 85 days were fine, and on 90 rain fell.

BRITISH WILD FLOWERS.

WATER-LILIES.—NYMPHEACEÆ.

(Continued from page 95.)

NUPHAR. YELLOW WATER-LILY.

GENERIC CHARACTER.—*Calyx* below the seed-vessel, of five or six large, leathery, concave, coloured, permanent leaves. *Petals* numerous, oblong, much smaller than the calyx; furrowed and honey-bearing at the back; proceeding, like the stamens, from the receptacle. *Stamens* very numerous, unconnected with the germen, line-shaped, bent back. *Anthers* line-shaped, of two parallel cells, closely attached to the inner surface of the upper part of each filament. *Germen* nearly stalkless, egg-shaped, with an elongation at the summit. *Style* none. *Stigma* stalkless, orbicular, convex, entire or notched, with many central radiating clefts. *Berry* leathery, smooth, pointed-egg-shaped, of as many cells as there are rays, finally pulpy within. *Seeds* numerous, smooth, egg-shaped, in several rows in each cell.

NUPHAR LUTEA: Common Yellow Water-lily; Water-can; Brandy-bottle.



Description.—It is a perennial. *Leaves* slightly egg-shaped, but nearly round, ten or twelve inches in diameter, floating nearly flat upon the water's surface, the edge only being slightly raised as if to keep the water from the upper surface, and the lobes at the stalk lapping over each other, tough, pliant, nerves or veins much raised beneath, upper surface bright green, but under surface paler; leaf-stalks smooth, three-sided, and their length depending on the depth of the water. Dr. Martyn had them 5½ feet long. *Flowers* an inch and-half in diameter, smelling like wine or

brandy, which, connected with the shape of the seed-vessel, has given occasion for one of its popular names. *Calyx* larger than the corolla, its sepals being almost an inch in diameter, roundish, erect, quite entire, slightly waved, smooth, tough, yellow, except at the base outside, where they are green. *Petals* fleshy, golden yellow, half-an-inch long, notched and grooved, from ten to twenty in number. *Stamens* very numerous, amounting from 100 to 165, pressing closely on the germ when the flower first opens, but falling back after shedding their pollen; filaments yellowish, thicker than the anthers, which are yellow, and two lines in length. *Germen* egg-shaped, blunt, smooth, terminated by a small roundish hollow. *Style* scarcely any, with a stigma yellow, unequally and slightly notched, rather convex, but depressed in the centre, and with eleven or twelve rays. *Seed-vessel* bottle-shaped, smooth, divided into twelve or more cells, and irregularly subdivided, so that each seed seems in its own cell. *Seeds* pointed egg-shaped, smooth, shining, and angularly-keeled. *Flower-stalks* nearly cylindrical, long in proportion to the depth of the water, always elevating the flower above its surface, but after impregnation bending down and ripening the seeds under water.

Nuphar differs from *Nymphaea* in having its petals and stamens inserted into a disk at the base of the germen. In *Nymphaea* the disk adheres to the side of the germen.

Sir J. E. Smith considers there is another species, which he describes as *Nuphar pumila*, or Least Yellow Water-lily, but we think with Willdenow and others, that it is sufficient to consider it only as a variety of *N. lutea*. There is no other distinctive character that we know of, than that the flowers are smaller, the petals paler, and the lobes of the leaves do not over-lap each other.

Places where found.—In slowly-flowing streams and pools; not uncommon.

Time of flowering.—July.

History.—Sir J. E. Smith retained for this genus the name *Nuphar*, given it by Dioscorides, and which name the modern Greeks, who make a cordial of its brandy-perfumed flowers, after the example of their forefathers, have but little corrupted, though the Turks have perverted it into *Nufar*. Withering says that the roots bruised in milk destroy the crickets and cockroaches which partake of it. An infusion of a pound of the fresh root in a gallon of water, and a pint of it taken night and morning, is said by the same authority to have cured a leprous eruption on the arm. The root, leaves, and flowers, are also employed in tanning, so that it must contain much astringent matter, or tannin. Swine eat it; goats are not fond of it; and cows, sheep, and horses, according to Linnaeus, refuse it. He also states that it drives away crickets from a house by its smoke when burnt. (Smith. Martyn. Withering. Baxter.)

It has been lately prominently and repeatedly stated in the columns of one of our older contemporaries, that "plants will, under certain circumstances, grow in the absence of leaves." If our contemporary merely intended that plants will emit fibrous roots, or that deciduous species will put forth leaves and even flowers whilst divested of foliage, he would not have given such prominence to his remarks, for these are phenomena

which we see every year among our newly-moved plants and upon our fruit walls.

It is, therefore, intended to be announced as an important discovery that plants which usually perform their growing processes and increase their solid matters by the aid of their leaves, may, "under certain circumstances," be made to increase that solid matter without leaves. One inference intended to be drawn from this

is, that farmers and gardeners may cut off the leaves of their Turnips, Carrots, and Mangold Wurtzel, or Beet, and whilst using those leaves for fodder, that the roots will go on increasing in size.

Now, we warn our readers, without any reservation, against any such practice. It is quite true that you may cut off the tops or leaves of those root-crops, and they will continue to put forth fresh leaves, and to increase in *bulk*, though more slowly than if the tops were left uninjured; but there will be no increase of *solid* matter. The roots will be more spongy, and contain a greater amount of water, but they will not increase in nutritive constituents. If only a portion of the leaves, and those only which age had rendered inactive, are removed; and if a sufficiency of young leaves are left to continue the elaborative functions, we all know that such treatment improves the vigour of the plant; but such judicious culture, for the better admission of air and light to the crop, is no modern discovery, but is to be found in every gardening book published during the last century. On the other hand, so far is the removal of all, or even nearly all, of the leaves of our root-crops from being of any benefit to them, that you may, by repeating the process, gradually render the roots worthless, and even kill them.

A similar delusion once existed, and perhaps still exists, relative to the Potato. It is well known that old tubers of this buried in sand, and kept in a warm dark place, will often produce a cluster of young tubers, without making any attempt to produce leaves. This fact we have seen quoted in justification of the practice which has been recommended of pulling off the stems of the Potato as soon as they showed symptoms of the murrain; the inference being, that the tubers of the crop would continue to grow without the leaves and stems, as in the other case. Such inference is most erroneous. A tuber buried in sand will produce young tubers, but it is entirely at the expense of its own substance; and so far from increasing in solid constituents, we believe that the old and young tubers actually contain more water and less solid matters than the old tuber before producing the young ones. This is easily tested, and we are of opinion that the results of our experiments will in every case be verified. We have weighed six Potatoes, and then had them sliced, and all the water evaporated from them by long exposure to a heat just below 212°. We have weighed three dozen other Potatoes, of similar size, and buried them in sand until some of them produced young tubers. We sliced six of these, and the young tubers they produced, and, having dried them in a similar manner, found in every instance that they yielded less solid matter, in proportion to their original weight, than the six which had not been allowed to produce young tubers.

We, therefore, repeat the warning to our readers, not to be induced to remove an excessive amount of leaves from their root-crops; and we take the opportunity to extend the warning against any extravagant recommendation which at any time goes the length of proving, if correct, that He who created plants was mistaken in

His plans. If experiments are stated which seem to sustain such a recommendation, be assured, beyond all doubt, that either the experiments or the deductions from them are erroneous. Never mind, though the authority which says that plants will increase in solid matter, "in the absence of leaves," tells you that the contrary opinion is "a deeply-rooted prejudice;" it is a prejudice sustained not only by science but by practice.

FORSYTH MSS.

THE projects of SIR JOHN SINCLAIR for turning the soil of Great Britain to advantage were not confined to farming and gardening, but embraced many other arts, foremost among which was extensive planting. These projects he continued after he lost the Presidentship of the Board of Agriculture, and down to the time of his death.

There is no doubt that his Whig politics were the cause, of his being deprived of the Presidentship, yet notwithstanding the castigation he received from Mr. Pitt, and notwithstanding all the government influence, he only lost the office by a single vote, thirteen voting for Lord Somerville, and twelve for Sir John Sinclair. This was in 1798, and in the year following we find a note from him to Mr. Forsyth, containing the following queries. It is dated from 35, Craven Street, Strand, 10th of December, 1799.

QUESTIONS REGARDING PLANTATIONS.

1. If plantations of 500 acres of waste lands were to be made in different parts of England, what do you imagine would be the average price of the land?
2. What would be the expense of fencing the land against sheep and cattle, if 500 acres were included in one plantation?
3. What would be the expense of planting 500 acres with larch; and for how much per acre could they be planted, and upheld for seven years?
4. What would probably be the value of a plantation of larch of thirty years growth, per tree, and per acre?

We must now conclude our notice of this indefatigable, useful, and benevolent man. No man, says one of his biographers, could devote himself with more ardour and perseverance for the benefit of his country, the support of all public institutions, and the reward of merit wherever found;—for the well-being of mankind was the object nearest his heart. How much his sovereign appreciated his merit is testified by his being created a Baronet in 1786, and by his being made a Privy Councillor in 1810. He died on the 21st of December, 1835, at his house in George Street, Edinburgh, aged 82 years.

COVENT GARDEN.

WHEN we entered upon the preparation of these reports, the only object we had in contemplation was to furnish an account of the state of the London fruit and vegetable markets, and of the different descriptions of produce there offered for sale. But, as we stated last week, various ideas force themselves on our mind as we proceed, and it may not be considered out of place to record them here. One of these, as we remarked in

our former notice, is the extended cultivation of fruit as an article of commerce. It is not, however, our intention to enter fully into a treatise on this subject, in what may be called the usual acceptation of the term, but simply to make a few remarks on opportunities which are afforded on almost every property, however small, for introducing some of the best and most profitable varieties, and employing the space which would otherwise be neglected. As regards the systematic planting of orchards, our able coadjutor in the fruit department has done, and will still continue to do, ample justice to this subject.

It has often occurred to us, in our journeyings through the different counties of England, that the hedge-rows and hedge-row-banks, with which the country is so profusely intersected, instead of being allowed to remain as they are, a mass of tangled brambles and bryony, relieved here and there with a stunted old pollard, might be planted with fruit-trees of such sorts and varieties as would not only be useful for home consumption, but which might produce a considerable revenue to the owner. We do not mean that there should be an universal and indiscriminate system of planting, but that it might be carried out to a certain extent, at least in such situations as the proprietors deem best adapted for the purpose. We have ourselves done so, and find, from experience, that it is a system which may be followed out even to a greater extent than we have practised it. We have even done more, for the approach to the dwelling-house is planted on either side with an avenue of Apples and Pears. The varieties we have chosen for this purpose are, of course, all choice as regards the quality of the fruit; but we have also selected them in reference to the habit of growth of the trees. All the *Apples* are of a round-headed habit, and the *Pears* of a pyramidal habit of growth, and in each row there is an apple and pear alternately. This has now been done some few years, and the trees are all well established. We leave our readers to imagine what effect this has produced: how it looks in spring, the Pears dangling with tassels of the purest white, the Apples decked with clusters of red and white, and pink blossoms, with the "little busy bee" humming from flower to flower; how in autumn, "the pulpy fruit with gold irradiate" delights the eye and pleases the taste; and how in winter they look as well as other trees do. If we are to have trees in our shrubberies, and approaches, and hedge-rows, why should they not be of such a kind as will be of some other use than merely to fill up a blank, form a blind, or afford shelter? If there should be a bad fruit year the loss could not be anything, for if the trees had been Ash, Oak, Elm, or Lime, they would have produced as little, and even less. The expense, then, of such a plantation of fruit trees is nothing except the first outlay. It occupies no space which could be appropriated to any other crop, and it answers all the purposes that would be expected from a plantation of timber-trees. And, by-the-by, speaking of timber-trees, we have in fruit-trees *timber* also; for the wood of both the apple

and the pear is constantly in demand, by turners for the manufacture of toys, and by cabinet-makers for inlaying. It may not be generally known that the blocks used by the floor-cloth manufacturers for printing the designs on the floor-cloth are all made of the wood of the pear-tree, so that even when the trees become old, they may be cut down and appropriated to some useful purpose.

We find our space will be hardly sufficient to enable us to enter upon a consideration of the varieties we would recommend for this description of planting this week; but in our next report we shall furnish lists, with observations. Meanwhile, our readers can be "turning the matter over in their minds," as this is now the best season for planting all sorts of fruit-trees, particularly on light soils, and even on those of medium texture, provided they are well drained, which all soils for fruit-trees should be. We shall now proceed to our more legitimate subject, namely, a notice of what has been doing in Covent Garden during the week. As regards prices we have nothing new to communicate. Both fruits and vegetables continue the same as last week, without any alteration. We must, therefore, refer our readers to our last number.

In *APPLES* we have observed an arrival of the *Royal Russet*, a fine old English variety, and a great favourite in many districts. There is one objection, however, to the russets; they are so liable to shrivel. We have also noticed a considerable supply of the *Summer Pearmain*, also a fine old autumn apple, and from its fine striped skin a great favourite in all markets. It is this variety which is generally, indeed we may almost say always, in nurseries under the name of *Royal Pearmain*, a name which by right belongs to what the Horticultural Society in their Catalogue call the *Herefordshire Pearmain*. The *Summer Pearmain* has also had its name changed, and we must allow with some considerable degree of justice too, to *Autumn Pearmain*, for certainly it is much more of an autumn than a summer variety. *Newtown Pippins*, and *Lady Apples*, are much more plentiful than they were last week; the latter particularly make the fruiterers' windows very gay. We find, however, there is an attempt to delude those who do not know better, by substituting a small flat red apple, similar in size and shape to the Lady Apple, for that variety. Any body, however, who has carefully observed the true variety once will be sure to know it again. Its shaded side is of a fine clear lemon-colour; and that next the sun is of the purest and deepest crimson, the whole shining as if varnished. The light and dark colours do not blend so gradually as in most other sorts, for the skin of this variety is so sensitive that even a twig or the slightest shade of a leaf is indicated. It is, in fact, as sensitive as the silverized plate of the dauguerréotypist; and on the red cheek of the little *Lady Apple* any device may be made by simply fastening the device on the fruit before it has received its full depth of colour. *Ribstones* continue plentiful, and there is generally a good supply of baking varieties.

In *PEARS* we have had some new arrivals, such as *Nelis d'Hiver* and the old *Crasanne*, both very fine des-

sert varieties. The others are *Glout Morceau*, *Duchesse d'Angoulême*, and *Passe Colmar*. *Beurré Diel* has also appeared during the week. Of most of these we shall speak on future occasions.

The CUT FLOWERS consist of *Heliotropes*, *Roses*, *Chrysanthemums*, *Scarlet Geraniums*, *Cinerarias*, *Camellias*, *Double Blue Violets*, *Chinese Primroses*, single and double; there were also some rare specimens in this way, consisting of *Euphorbium jacquiniflora*, *Oncidium lanceanum*, *Passiflora cærulea racemosa*, *Dendrobium spectabile*, and some other rare stove plants. H.

GOSSIP.

THE exhibition days at the *Chiswick Gardens* of the Horticultural Society will be, in 1853, on the 14th of May, 11th of June, and 9th of July.

At page 144 of our fifth volume, when giving an account of the *Stanwick Nectarine*, we thus expressed ourselves:—"The Duke of Northumberland having munificently given buds from this Nectarine to raise trees for sale, the proceeds to be given to the Gardeners' Benevolent Institution; and Mr. Rivers, in a similar good spirit, having raised these trees without charge for their propagation, we have thought it right to place these particulars before our readers; but we do no more. Without expressing our opinion upon the merits of the Nectarine, we sincerely hope that both the Institution and the purchasers of the trees may be one and all benefited." For expressing ourselves so guardedly we were blamed at the time, but we were immovable in our resolution not to recommend the Nectarine until its value in our climate was proved by successful cultivation; and those who blamed us must now "eat humble pie." We are sorry to read the following, whilst we congratulate ourselves that we did not aid in ministering to the disappointment. Mr. Ingram, the Queen's gardener, says, "The Stanwick Nectarine is unfit for planting on the open walls of the kitchen-garden;" and another authority says that, even when under glass, it requires fire-heat, and that in flavour it is not superior to the Elruge.

It is very well known that as long since as the time of the Roman emperors, some transparent stone (*Specularis lapis*) was split into thin panes, and used as a shelter for Cucumbers, &c. There can be no doubt, from the description given of it by Pliny in his Natural History (Book 36, Chapter 22), that this stone was the same as our *Talc*. It has been customary to think that this has been quite superseded for gardening purposes. Such, however, is not the case; and since rough glass has been found superior for plants to that which is perfectly transparent, there is reason to believe that talc for similar purposes may be employed. At all events, it is worthy of a trial, for our contemporary, *The Builder*, says, that it may be supplied considerably cheaper than glass, it is much less liable to breakage, and that being lighter, the frames of houses and pits may be less stout. It is added, "Talc has been tried in several places, and found to answer." If any of our

readers have tried it, they will much oblige us by stating the results of their experience.

We have been asked by a correspondent (*Norwich*) whether "soil and temperature" have any influence in rendering one English county less capable of producing *Cheese* than another county more celebrated? and we have no hesitation in saying, that in such cases we believe that soil and temperature have nothing to do with the result. We are quite aware of the old satirical story of the rats eating the millstones and leaving the Suffolk cheeses, yet we are quite of opinion that, with equal dairy skill, and equal richness of pasture, as good cheeses could be made in the east as in the west of England. In confirmation of our opinion, we quote the following from the *Preston Guardian*:—

"So many exaggerated statements have appeared in the papers, respecting the *Gift-Hall Cheese Dairy*, that we have been induced to procure a true statement of the facts, which we have obtained from J. Wilson Patten, Esq., M.P., himself the owner. Gift-hall is a farm in Winmarleigh, North Lancashire, which the proprietor has in his own hand. Cheese-making is a prominent part of farming upon his estate in that district; the dairies of some of his tenants are celebrated, and obtain good prices, while others are sold at inferior rates. Mr. Patten, residing near the borders of Cheshire, and hearing of certain Cheshire farmers getting high prices for the London market, felt desirous to solve the problem, whether the quality of cheese depended on the *land* or on the *maker*, and if on the latter, whether as good cheese might not be made in Lancashire as Cheshire. He proceeded with the experiment in every way so as to give a fair and unbiassed result. He purchased fifty-three cows; and having to buy them off hand, of various breeds, they cannot be considered so select a stock as if he had been farming two or three years. Some calved in January, some in February, some in March, and others later. The first cheese was made on the 18th of April, and up to the 20th of October there were 320 cheeses made. These have not been weighed; but Mr. Patten has no doubt but they will fully average 50lb. each. There are some that weigh as much as 70lbs.; but when they are weighed we will give the exact weight. Of course, in estimating the weight of the whole dairy, we shall have the 'later makes' to add to them. At the estimate of 50 lbs. each, the quantity up to the above date will be 6 tons, 13 cwt., 1 quarter and 10lbs., calculating 120 lbs. to the cwt. No cream was taken off to make butter; but the 'whey butter' has all been kept, and of this there are either six or seven mugs, supposed to average about 60lb. each. We will hereafter give the exact weight of this, and the price it sells for. This celebrated dairy was sold this week to a respectable factor residing at Warrington, and who has a connexion with the London market, and the dairy is intended to be forwarded to London. The price is 63s., taking all together, including the spring cheese, which are never so good as the others, but not including the 'back ends,' which, of course, are also inferior and not ready. The celebrity of this dairy is owing entirely to the dairymaid, Mrs. Dutton, who formerly lived with Mr. Hixley, of Cheshire. Being always noted for making a choice dairy, Mr. Patten engaged her to come to Gift-hall, on purpose to conduct the experiment. The cheese-factor at Warrington had formerly bought Mr. Hixley's dairy when Mrs. Dutton made it, which probably led to the present purchase at Gift-hall. The above are the facts of the case; and we shall be glad to hear of the other farmers on Mr. Patten's estate, or in other parts of Lancashire, being able to equal this experiment. But to prevent disappointment, and to present the matter in a true light, we think a few words of explanation may be useful. And, first, there are certain dairies both in Cheshire and Lancashire that acquire a value by mere *fame*, whilst many others, equally good, cannot command near the same price. Second, the London market, for what is considered a first-rate article, requires a peculiar make, which is not easy to secure; but when a dairy happens to be exactly the thing,

unusually large prices are generally obtained. We do not think that the best Cheshire cheese are at all superior to the best Lancashire; but still fashion or fancy has given them superiority in the London market. And it is this fashion or fancy that has added so large an artificial value to double Gloucester and Stilton above their real merit. To show that it is not the mere fact of a dairy being of the *Cheshire* make that will command a large price, we may name, that while here and there a dairy in Cheshire was fetching as much as the Gift-hall dairy, and some considerably more, the general run of prices at the last Chester fair was from 42s. to 53s., and not a single dairy commanded the prices above named. It is proper that farmers should know that it is not by making *Cheshire* cheese merely that they will get higher prices, but by making that peculiar quality that suits the London market."

The following is a list of the *Horticultural and Poultry Shows* of which we are at present aware. We shall be obliged by any of our readers sending us additions to the list, and giving the address of the Secretaries.

HORTICULTURAL SHOWS.

BURY ST. EDMUNDS, Nov. 26 (Chrysanthemums). (Sec. G. P. Clay, Esq.)

CALEDONIAN (Inverleith Row), Edinburgh, Dec. 2.

LONDON FLORICULTURAL (Exeter Hall, Strand), Dec. 14.

SOUTH LONDON (ROYAL), Dec. 9+, 16.

POULTRY SHOWS.

BIRMINGHAM AND MIDLAND COUNTIES, 14th, 15th, 16th, and 17th December.

BRISTOL AGRICULTURAL, December 7th, 8th, and 9th. (Sec. James Marmont.)

CORNWALL (PENZANCE), January 10th, and 11th. (Secs. Rev. W. W. Wingfield, Gulval Vicarage, and E. H. Rodd, Esq.)

HONITON, January 12th. (Sec. H. K. Venn.)

WINCHESTER, December 1st. (Secs. G. W. Johnson and J. Colson.)

NURSERYMEN AND THEIR FRUITS.

AMONGST the many disappointments which flesh is heir to, few are more annoying than those connected with choice fruits. It is, indeed, exceedingly so for a person to find, after building expensive structures, or garden walls, and having his patience taxed by waiting some three or four years for produce, to find that his supposed Hambro's are Frontignans, or his desired Galande Peach is the Early Anne; yet these are things that happen every day somewhere, and the writer of this has undergone several severe disappointments of the kind in his time. Our nurserymen certainly are not the most negligent tradesmen of the day, by any means; but this grievance happens so frequently as to call on them for increased vigilance in the propagation of their fruits, and in the execution of their orders. Some years since we had determined to have a Galande Peach-tree in a favourite position: this was desirable, in order to furnish a link wanting in the chain of succession. One was obtained from a first-rate nurseryman, and in three years, on fruiting, behold it was a Royal George. Again, soon afterwards it became desirable to plant a very late peach, and a Late Admirable was chosen; and behold, on fruiting, we had another Royal George. Now, this was really infamous, and the annoyance was by no means lessened by a good ground for suspicion that the Royal George had been *knowingly* substituted.

It so happens that nurserymen have not at all times good trees of our more tender peaches; and the Royal

George, being a free grower, might, by a not over-particular foreman, be substituted. We do hope our esteemed friend, Mr. Appleby, will keep a watchful eye on such matters, and this we cannot doubt,—having been a gardener himself, he is keenly alive to the importance of accuracy in such things, and, by thus taking a stand from the first, will be in a position to render the gardening public a service.

Much is expected of all classes in these days, and the nurseryman must use whip and spur in order to keep up with the foremost rank. One of the chief features of our day is the division of labour in our various trades, and this practice has reached the nurseryman in common with the rest. Hence we have rose florists, fruit growers, cultivators of exotics for exhibition purposes, &c.; and we do apprehend that, as the tide flows, this division of labour is destined still farther to extend in the gardening world.

This is as it should be; for the business of a nurseryman was fast becoming of too multifarious a character to be well carried out by one firm in all its branches. We all know, by experience, that much less error takes place with such things as Roses by our rose-growers in these days than by the old mixed nursery system. We do not wish it to be inferred, however, that these rose-growers cannot supply a general order—by no means; but the fact is, they throw their chief strength into the roses, the rest being more of a subsidiary character.

The confusion in the nomenclature of our fruits, hitherto existing, has, indeed, been an enormous grievance, and seems to call either for fresh arrangements, or a far better administration of those existing. We are quite aware that what is called "the trade" is a very sensitive hydra-headed creature; and, doubtless, justly so; for, indeed, its well-being depends, in the main, on its integrity. And it is because we would fain increase even its high character, that we have the tenacity to charge it with the possibility of not being entirely immaculate. Moreover, we owe a duty to the public, whose precedency in this case is indisputable.

Under such circumstances, we rejoice to see a weekly report of that great emporium of fruits and vegetables, Covent Garden market, added to the pages of *THE COTTAGE GARDENER*, and to which the initial "H." is appended; and which letter seems to point to a first-rate pomologist, whose very style and fulness of information seems to betray him. These reports will be invaluable, but country folks would fain have the retail prices distinguished from the wholesale prices. This is, we are aware, a nice task to perform; but who shall say what is impossible in these days?

And here another word to our nurserymen, who certainly in their kind are nowhere excelled: no, not in any country. Since the million will have gardens, and possess the desire, without the practical knowledge, to avail themselves of superior fruits, some means should be placed within their reach of knowing at a glimpse what will suit their purpose. Catalogues they understand not; neither have they time or inclination to collect facts by a slow and tiresome detail, which would put them in a position with the really practical man in adapting kinds to their necessities, or as subordinate to their schemes. Here we must point to the importance of a growing art, the modelling fruits, as well as flowers, in wax. Why not have a cabinet of wax models of fruits as a very proper and necessary appendage to a nurseryman's counter, or shop-window? We are led to suggest this course in consequence of showing the very superior manner in which some of our rising artistes manage these things. Most of our readers have seen the Kew Garden's Museum, or if not this interesting cabinet of models of fruits, they have seen such things in the great metropolis. But we can assure them, that not in the metropolis alone are these matters well carried out, the

taste has fairly beset our provincials. At the last Liverpool exhibition, for instance, Miss Newton, the wax-flower lady, had a case which would not have disgraced the counter of the first seed-shops in Britain. This was mostly composed of pears and apples, and the merest novice would have traced the actual fruits by the lineaments therein portrayed. Incorrectness in colouring seems to be the only charge against these wax modellers; and, doubtless, it is a nice point to hit off the peculiarities of our fruits in this respect; but such difficulties will vanish before that extra perseverance engendered by the increasing demands.

Now, as it appears to us, there are at least two strong reasons why nurserymen might be expected to adopt such a plan: first, its utility to their customers; and secondly, for the information of their staff. As it is, but few of these persons can become familiar with the character of the majority of the fruits they sell; their young trees bear not whilst in their hands; in offering information, therefore, to ignorant purchasers, it is not expected, under such circumstances, to be very complete. But in these days we do hold it essential that every tradesman should be able correctly to describe the character of the wares he deals in. Advertisements are all very proper; catalogues very proper; but none of these will produce that impression on the mind of the anxious purchaser that well-executed wax models would do. For instance, we will here give an extract (descriptive) from the fruit catalogue of one of our most respectable nurserymen—

“GRAPES—*St. Peter's*; black; round; ripens late, &c.
PEARS—*Beurré Bose*; large; good; melting, &c.
APPLES—*Kerry Pippin*; small; first quality; table, &c.”

Now, these taken at random, may serve to illustrate the matter; and we may ask how any novice could form a just idea of the true form, general character, and peculiarly fine bloom of the *West's St. Peter's Grape* from so narrow a description? Then the *Beurré Bose*, which carries such an extraordinary impress on the table when in full size, so peculiar in character; the description would apply equally to a *Beurré Diel*. And to finish: the *Kerry Pippin* Apple; to say nothing of the very superior flavour and peculiarly high-colouring of the flesh, almost an orange colour, no one could picture to himself the handsome appearance on the table of a dish of high-coloured *Kerry's* in the middle of September. And now we will take it for granted that anything which will greatly serve and please customers it is the nurseryman's interest to carry out.

We remember, some years since, when the late Mr. Loudon—who was always aiming at progress—used all the influence his pen could command in trying to improve the character of our nurseryman's catalogues, which had previously been very dry affairs. This, although a somewhat up-hill work at first, at last progressed almost beyond his expectations; and now we have them in the plant way of as high a botanical character as could be desired; and, moreover, through a well-conceived grouping, most useful guides to the purchaser.

Such trays, or cabinets, then, we do urge would promote the culture of fruits, as well as a well-studied and correct nomenclature; and they would be a sort of guarantee that the tradesman was quite in earnest about his collection. They would also lead to increased inquiries on the part of the public; to an enlarged study of fruits, their characters, qualities, &c.; their origin; and, lastly, habits of growth. The last is an important matter, as on a knowledge of such facts must, in a degree, all successful culture be based. To this end we would beg to push the question a little farther, and to suggest that a leaf, a modelled blossom, and a twig of the kind in question, should accompany every

specimen. These, with a tabular card sheet, setting forth, in distinct columns, something like the following: *Uses; qualities; when in use and their keeping; bearing character; eligibilities as to site, &c.; peculiarities as to soil, or otherwise; and, indeed, any other information likely to be needed on the spot.* Now, this well carried out would, we feel assured, speedily raise the character of any fruit grown. The public would feel assured that the mere carrying out the idea would necessarily impose so much real attention to fruits on the part of the vendor, as would of itself lead to that fulness of information requisite to guide the public.

It remains, whilst on this subject, to offer another suggestion, for which we have not the assurance to claim novelty, but we possess a desire to see it made an indispensable qualification of one who aims at being a public purveyor in the matter of fruits. It is this: that every grower plant out a tree, under favourable circumstances, of every kind he receives into his catalogue, in order to let it attain maturity, and fruit if it will; its products tending, of course, to establish or destroy the identity of the wax model. This is surely a wholesome practice, both as to the salesman and his customers: in the former leading to careful selection and a facility of obtaining genuine grafts and buds—and in the latter, engendering that confidence which is the life and soul of all such transactions.

Had we a nursery we should cause these specimen-fruits to accompany all the principal lines or promenades, and every one should have a descriptive label, bearing reference to the model in the seed-shop; as also to the tabular account. R. ERRINGTON.

HARDY AND HALF-HARDY BULBS.

ON the first appearance of THE COTTAGE GARDENER, I promised the Editor, in my haste, that if I could not serve him in any other way, I could “do” the bulbs for him. Ever since, I have found that promises to Editors are like marriage vows—if you once break them, you will probably be out at elbows to the end of the chapter. As if to prove all this, I have now on the table seven folio pages full of the names of hardy and half-hardy bulbs, alphabetically arranged, with their natural orders indicated, all culled, industriously, from the pages of our useful COTTAGE GARDENERS' DICTIONARY by a correspondent (S. S. S.); and I am to give, from the epitome condensed by my friend, Mr. Fish, in the pages of the Dictionary aforesaid, an extended view of their propagation and cultivation, in conformity with my hasty promise.

If I were to do this in a consecutive order, from week to week, and from *Agapanthus* to *Zephyranthes*, I should be called to account; therefore I shall only give a chapter on them now and then, when nothing else is more pressing.

To save repetitions, I shall observe at once, that the different *soils for bulbs* ought to be well exposed for some time before using, so as that all vegetable remains in the compost may be quite decayed, and well incorporated with the mass by frequent turnings; that most bulbs are much improved by beds far deeper than many good gardeners are aware of; that planting with a dibber is injurious to many delicate bulbs, unless good clean sand is used at the same time, and if it is, planting with a dibber is the best practice. The reason of this is, that the sides of a hole made by a dibber will fall heavy on the bulb after the first frost or heavy rain, or, if they stand, will be apt to hold water too long, or make more of it pass down over the bulb than would do so if all the soil over the bulb were free and loose. By making a comparatively large hole for the size of the bulb with a sharp-pointed stick, or dibber,

and then putting in an inch or two inches of sand, then the bulb, after that by filling over the bulb, and all up the hole to the surface of the bed or border, with more sand, all the bad consequences of dibber-planting are got rid of, and a freer passage for the leaves through the column of sand is provided, and the sand, besides lying less heavily over the bulb, is not so apt to injure it as the soil is; besides, the wire-worms, and other grubs, which delight in the mischief they do to bulbs, do not like to work among sand. I suppose sharp silver or river sand tickles them too much to be pleasant. Add to this, that if the mark-stick or tally over the bulb is lost, you have only to scrape a little on the surface till you come to the top of the sand column, and then you are sure of the place.

Almost all greenhouse bulbs, particularly those of them which do not grow actively during our winter, may be grown in a border by the side of a wall, or other building, if they are planted six inches deep, and a slight protection is given from heavy rains and frost. A very small bulb will be able to push up its leaves six inches through a column of sand; and I have seen a *Crocus*, that was accidentally buried two feet deep in trenching a border, come up as vigorously in the leaf as if it were only four inches deep; and I have often seen the *Crocus* flower when the tube of the flower must have been a foot long, owing to the depth of the covering over the bulbs. On the whole, therefore, I shall lay it down as a rule, that all bulbs, whether hardy or otherwise, that grow to the size of an ordinary *Crocus*, may be planted six inches deep, if sand is placed all round them, and straight over them to the surface; and that four inches deep is the safest for such bulbs as do not grow to the size of a common *Crocus*; and that without sand, or very sandy soil, these depths are too much, although they may not show the bad effects for the first few years after planting.

I am rather ambitious that these papers on Bulbs should be as complete and useful as our present knowledge would warrant us to expect; therefore, if I omit anything, or say things that a reader does not comprehend—or if he knows, from *actual experience*, a better way than I shall point out—pray let him write directly, as soon as he reads each paper, and put what he means in as few words as possible.

AGAPANTHUS umbellatus, *albidus*, and *variegatus*, are three forms of the same beautiful plant—the blue African Lily. Some people believe that there are two more forms of it under cultivation, one much taller, and another considerably less than the common one. I cannot decide the point; but I believe the supposed difference arose from different modes of treatment—at least, I never saw any form of the blue one which could not be referred to the common sort. *Albidus* is not such a strong grower as *umbellatus*, and the flowers are of a bluish-white colour. It is a desirable variety, and so is the variegated one. There are no other bulbs that I am acquainted with, except some of the Asiatic great *Crinums*, which delight so much in our very strongest loams, fertilised by the richest manures, as the blue African Lily; and it will bloom and look green in a pot with soil that would stint an *Aloe*, *provided* abundance of water is given. I have known it to look well with the roots immersed in water for four months during the summer. It seeds freely with some gardeners, but is seldom increased that way, as it stoles, or makes side suckers so freely.

The most singular thing that I know of in the whole order of bulbs is, that this, a true evergreen, will flower yearly, for many years in succession, out in the open ground, after the leaves are destroyed every winter by frost: but of the fact itself, I am quite sure, I never knew a frost under 7° injure the leaves, while 10° or 12° of frost will kill them outright. It makes a bold,

fine-looking bed, and it is the most useful pot-plant we have to stand out in summer about the doors, or accompanying architectural works, or in terrace-gardens, as the leaves take no hurt with any wind, and the flower-stems are so stiff that a gale has no effect on them. It can be kept over the winter in pots, with less light and with harder treatment than any other bulb, and very little water will do for it from November to March. March or April is the best time to divide it for increase; but it may be divided any day from that time to October, if not all the year round. It is necessary to use a sharp spade for dividing it, for the roots are strong and much interlaced among each other. A small portion of roots will do with each division, and, in potting them, use strong, stiff loam and very rotten dung, leaving more room for watering than is usual with other plants, as it requires large supplies of water during the summer.

Agapanthus albiflorus is only a variety of the former, and of much less strength. It requires lighter soil, and more care in winter, but is not cultivated nearly so much as it deserves. There can be no question about getting new and useful varieties if the pollen of the blue one were applied to the flowers of this; but I never experimented on this family, and cannot say if this will ever seed.

Agapanthus variegatus also is scarce; but now that a taste for variegated plants is on the rise it will be more run after. Neither of the varieties make such free growth, or produce suckers like the old species; and both of them require lighter soil, and more careful treatment than the old species. I never heard if either could be trusted out-of-doors in winter; probably not. They belong to a section of the order Lilyworts, named after *Hemerocallis*, the day lily. The others best known of this section are the sweet tube rose, the beautiful *Blandfordias*, the splendid *Tritomas*, and the rigid New Zealand Flax *Phormium tenax*.

ALBUCA.—This is a genus of South African Lilyworts, belonging to the section of Squills (*Scillaceæ*), a section which abounds in beautiful bulbs, all of which cast their leaves when going to rest. The species of *Albuca* are numerous, and very ill defined; many of them come here with assortments of "Cape bulbs," but they are soon lost. The bulbs are generally small, light-coloured, and very tender-skinned; and the least mishap causes them to rot, as it does the *Lachenalias*, from the same country. Some of them are the very smallest bulbs at the Cape, and almost defy our attempts at growing them for any length of time; and others throw up stout flower-stalks, two or more feet high, with a crowd of little white flowers on the top. The most of them have white, or creamy-yellow flowers; but the whole family, like the *Alliums*, are more for botanic gardens than for general culture, and, what is singular, I believe they all dislike peat. Very sandy loam seems more favourable to them. I lost nine kinds of them in two years, by putting them in a peat bed, inside a cold frame. They came direct from the Cape in May, and that may have caused the failure, as all of them begin to grow late in the autumn.

We mentioned seventeen species of them in the Dictionary, but I much doubt if half that number could be bought in the trade. *Albuca major*, *fragrans*, *aurea*, and *viridiflora*, would give a good representation of the genus; but *fragrans* is very ticklish to keep. Pot-culture would suit them best; and the moment the leaves turn yellow, the bulbs should be turned out of the pots, and put on a shelf to dry in the sun for a few days, and then to be laid by in silver sand till the end of October. At potting-time, place sand round the bulbs, and do not water them till the leaves appear.

ALSTRÖMERIA, not *Alstromæria*, as some spell it.—As far as we know, all the species of this genus of fine plants have tuberous or fascicled roots. All of them in

our gardens live out the winter with little or no protection; or, if they are grown in pots, they require abundance of air, and large supplies of water while in a growing state. They delight in deep, rich, light soil, well drained, except *A. aurea*, which will do in stiff, damp clay, as well as in common, rich, kitchen-garden soil. The species are exceedingly difficult to distinguish from varieties, as much so as *Calceolarias*; and from one peculiarity common to them all, they are liable to cross each other in a state of nature: hence the great confusion in the names. This peculiarity is in the style, or female organ, which never ripens for the pollen till all the pollen is dead and gone in the same flower; but as the flowers do not all open at the same time, the stigma of the foremost flower gets fertilized by the pollen of the next that opens; meantime, it is as likely as not that strange pollen may find access when more than one kind grow together.

Another genus, called *Bomaria*, is often confounded with *Alströmeria*; but the distinction between them is evident, without any knowledge of botanical points. All the *Bomarias* twine like hops, but none of the *Alströmerias* do. Some of my friends assert that they crossed *Bomaria acutifolia* with a species of *Alströmeria*; but, I am so acquainted with the ways of both, that I would as soon believe in the union of the man-in-the-moon with Diana of the Ephesians. *Collania* and *Sphærine*, two genera of which we have no species in cultivation, intervene between *Alströmeria* and *Bomaria*; and, if any reliance can be placed on their characters, none of them would or could be crossed with either an *Alströmeria* or *Bomaria*. I am thus particular, because, sooner or later, both of them will be great favourites with the cross-breeder.

A. aurea, alias *Aurantiaca* (golden).—Native of the Island of Chiloe; flowers orange, streaked with red, on stalks three to four feet high; quite hardy in England; seeds freely, and increases by the roots as fast as Spear-grass. It ought to be as common as Poppies. I have had it four feet high in clay so stiff that it could not be dug without dipping the spade in water every other thrust; and I believe it would grow in a marsh, or at the edges of ponds or lakes. None of the family like dry chalky soil.

A. Cummingiana.—Named after Mr. Cumming, who first discovered it "on mountains near Valparaiso." It comes nearest to *Hookeriana*; flowers all the summer and down to November, in the open air, and is as hardy, apparently, as a Crocus, if planted six inches deep in rich loamy soil. The stalks are from ten to fifteen inches high, and the flowers of various colours—yellow, brown, and green, chiefly.

A. caryophyllæa (Clove-scented).—This is the proper name for the old *A. ligtu*, a stove plant, which requires light soil, and rest from October till March. It flowers soon after it begins to grow; and as soon as the stems cease growing the plants should be removed into a greenhouse for the rest of the season; without this change it seldom flowers at all, and now it is very scarce. The flowers, crimson and white, are very handsome.

A. hemantha (Blood-coloured).—Notwithstanding the name, the colour of the flowers is not much different from that of *aurea*; but in the meadows near Antuco, in South Chili, it sports naturally into white, vermillion, yellow, orange, and lemon colours. It is also the mother of thirty or forty varieties, called *Van Hout's Alströmerias*; and all of them rest three or four months, from July, and they ought to be taken up every second year, as they bury themselves deeper and deeper at every growth. A tulip bed, or one for hyacinths, made after the old florist school, suits them best, and they should be abundantly watered after they throw up for flower, and they grow slowly from November through the

winter, and, if they appear above ground early in the spring, they ought to have a slight protection.

A. Neillii.—Named after the late Dr. Neil, of Edinburgh, the best friend Scotch gardeners ever had. I am afraid this plant is lost; it was very difficult to manage. The flowers are of a very pink colour, with yellow blotches. I only saw one plant of this. It had all the appearance of being a genuine species, and wanted the twist in the leaf so common in the genus. Some of the species have been seen growing out of the clefts of the rocks, and this appears to me to be one of them.

D. BEATON.

(To be continued.)

AZALEA JAPONICA.—WREST PARK.

THE comparing of notes some time ago, if report spoke true, seemed to be much enjoyed by our readers. None require to be more reminded that there may be *unity* amid the greatest apparent *diversity*, than those who make gardening a pleasant recreation, or a professional pursuit. Often differences are more seeming than real; and the hair's-breadth of advantage that one system possesses over another, can only be demonstrated when, with all their details, they are brought closely in contact. Without this we are too apt, from our imitative faculties, to chime in practically with the dogma, that "what is best administered is best," while all the time there may be some little error in the very thing administered. A striking result so arrests the attention, that to equal the same, most people imagine that they must attend to every iota in a similar manner; while others, more experienced, and generally intelligent, can at once see, that in similar circumstances they can secure the same result with less trouble and expense. It would not be safe for the inexperienced to generalise, as their very ignorance might lead them to regard some apparently trifling matters as of no importance, though these, to the more conversant, would be regarded as the main cardinal points of the system. Hence, I find that the trifles of processes are the things about which young beginners chiefly concern themselves; by-and-by they will find that comparatively a few principles will sustain them, instead of a long calendar of routines. In the meantime, discrepancies in practice sadly puzzle them; they follow our advice this week, the opinion of another the week following, and the counsel of a third afterwards, and then how generally annoyed they are when result-time comes! Had they persisted in any one system all might have been satisfactory. They are told there are many ways to one end; and so there may be, and perhaps not one preferable to the others; but how or when is the end to be gained, when, instead of following out one way to its termination, you keep scrambling from one way across to another? I would meet every doubt if I knew them, and *could* solve them, and reconcile discrepancies if not beyond my ability. We are too constantly needing instruction to imagine we really know very much. Truth has been said to lie deep in a well; hence, few can see her, few find her, and many, with their cumbrous machinery, sink her deeper, and cover her out of sight. I believe she mirrors herself from the smooth surface of the unruffled pool at our feet, and when once we fairly get a glance of her, the only wonder is, not anything about the exceeding difficulty of finding her, but that we had been so blinded by pride and self-conceit as not to see her clearly before. We have all our pet systems, yet nothing would please us more than to be able to improve our favourite plans, or even put an extinguisher on them, and to adopt that which was decidedly superior. What better for this than the statement of difficulties and discrepancies, and the calm, friendly discussion of any differences. Thus,

though living comparatively in retirement, as many gardeners do, and perhaps not free from self-opinionatedness, the usual concomitant of such circumstances, we should, through the pages of our COTTAGE GARDENER, possess many of the advantages alike of the class-room and of congenial society, where thought is met by thought, opinion is tested by opinion, and mind is directly brought into contact with mind.

Azalea Japonica (see p. 82).—Our friend, Mr. Beaton, hoped I might fish out something about this interesting plant. I am at times half-inclined to envy him his present privileges, of being able to see everything that is wonderful, beautiful, and new. In the present case I am fairly upsides with him. I saw the plant before the branch was cut in the evening preparatory to its being taken to London the following morning. I can fully confirm the fact, that the huge panicle was only one of many; and so generally fine were they, that the selecting of the one to be sent was almost a matter of hap-hazard. Even Mr. Snow could not fix upon one that was markedly superior. The plant seemed about seven feet high, and the top nearly as much in diameter. Now for the *position*, as that is the most important matter as to the plant flourishing so well. Imagine you are standing on the east side of a high ornamental wall that runs from north to south. At the south end, a dwarf wall goes at right angles to the west, for the length of somewhere about twenty feet, and then it takes off, at right angles, to the south again for a good distance, constituting, in fact, the eastern boundary of the fruit and kitchen garden. In front of this wall there is a border for shrubs—the exact width of the short wall above referred to—so that the front of the border ranges in a line with the ornamental wall. At the extreme north end of this border, and hence on the south side of the short wall, protected, therefore, from the north and the west, rather freely exposed to the east, but a little shaded by higher things from the south, stands this beautiful plant. The border consists of deep sandy loam; but it is very likely that Mr. Snow gave his favourites a little assistance from leaf mould and peat when young. There are many fine specimens on this border besides, such as *Spiræa Lindleyana*, *Cupressus torulosa*, *C. thurifera*, &c. Whether the plant will thrive equally well in exposed situations, I am unable to say. It was the first time I had seen it in bloom; and I was rather surprised at the colour being whitish, as most descriptions had spoken of it being green. Even though it should be proved hardy enough for exposed places, yet the conservative wall (of which more anon) would be its proper position, as, unless it bloomed *earlier*, it would be apt to be destroyed by frost before the bloom expanded. No doubt we shall hear more about it.

I have mentioned all this the more, because, though *Wrest Park Gardens* lie rather low, they are protected in every direction. A description of the place would at once show this; but this would require considerable space, and I have not got one note on the subject. To give our friends such a slight idea as might incite them to a pilgrim's survey for themselves, I will present them with a few pencil-marks from memory—such as I frequently give, in lieu of a chart, by a few strokes of the pen, to strangers who are going farther, and who complain of a double difficulty: first, that when at a standstill they can find no one to exercise the inquisitive bump on; and, secondly, that when they do find a rustic, they have to stare at each other, like the respective parties in the last recorded miracle; and from the same cause, their respective *patois* being Greek to each other.

The nearest approach to *Wrest Park*, by rail, is *Hitchin*, on the Great Northern; and from thence it is distant somewhere about eight miles. From *Luton* it is

nine miles; and I forget how far from *Amptill* and *Bedford*. The road between these respective places passes the village of *Tilsoe*, where the main entrance is. Here, however, you enter,—I would advise you to go; and this shall be our first pencil *dot*. The gates are beautifully artistic; but what an avenue, or rather triple avenue within—formed of *Elms* and *Sweet Chesnuts*! The central, or carriage one is very unique. Had the Gothic style “loomed in the *future*,” the first architect of taste that had a glance at that avenue would have made it a matter of the *present*. The huge arms of the large trees, mostly naturally, but perhaps a little assisted, span and meet far above your heads, resembling a splendid Gothic cathedral. Ere long, as you go eastward, you soon descry the walls of the garden; Mr. Snow's house at the west corner of the north wall, house and wall being of an ornamental character; and the latter passing eastward until it joins the mansion and offices. The mansion offices, kitchen, fruit, and flower-gardens, are new: the park and main features of the pleasure-ground are I do not know or recollect how old, though constantly being improved. The mansion is in the *Louis Quatorze* style; and as everything connected with it was made from the designs of *Earl de Grey* himself, some conception may be formed of the chaste beauty everywhere apparent, and all impressed with one uniform character, within and without. The whole place may be said to be “self-contained,” that is, though it forms a fine feature in the landscape, when seen from high grounds, to the south-east, south, and south-west, you can, when there, see nothing beyond its boundaries. There is only one exception. Standing on or near the noble stone terrace, on the south side of the mansion, ornamented with statues and vases, you glance along a beautiful glade. First, there is a noble walk, thirty feet in width, proceeding right on, near to a large long parallelogram of water, where the walk parts right and left, and passes along both banks of the water, backed on either side with woods and pleasure-grounds. A pretty temple in the centre terminates the *home* view; but over its top you see bare and rugged and barren heights in the distance, which some might consider an agreeable relief, but which many more would feel to be a *Paul Pry* intrusion upon the soft, mellow beauty and rich luxuriance everywhere around. If such bare heights *could* be covered with wood, with a tower or cottage peeping through it, the effect would be harmonious and enchanting. In the woods and pleasure-grounds, on either side of the piece of water, are many walks, in which hours may be agreeably spent, more especially if accompanied by one versed in local traditionary, and legendary lore. Turning again your back upon the water, and approaching the mansion, you are struck now, if not before, with the vast extent of lawn. A considerable distance to the westward, you will notice a beautiful building, at one time used as a pavilion, or banquet hall. Anon, right and left, you stand opposite another avenue, terminated at either end by commemorative obelisks. Presently, another walk branches off right and left; that to the west leading you to the centre of a beautiful building, standing on the highest of a series of grass terraces. This building is filled with splendid orange trees, imported from the Continent last season, and now encased in *Beck's* beautiful slate tubs. As an architectural fabric, this house presents a fine effect; but as a habitation for plants, the back wall being opaque, the front is decidedly too massive and heavy. This is more apparent when, on entering, you perceive the roof is chiefly opaque, relieved only by upright square lanthorn-like boxes, glazed with glass all round, but from which the rays of light are too diffused before they reach the plants. The whole of the roof might easily, and more economically, have been of glass, without interfering in the least with the architectural effect. This is only one instance added

to the many, that the most accomplished architects are but indifferent gardeners. That such buildings would answer on the Continent, we believe; but have we the sky and the climate of France and Italy?

Retracing our steps, or taking a short cut across the lawn, we again get on the broad walk and approach the mansion. On the east side of the broad walk, and just below the terrace, is a scroll-like Italian garden, ornamented with marble figures, and having some beautiful young standards of Portugal laurels; but we must mount the terrace to see it well. The design seems somewhat intricate; but then every turn and bend are so graceful. Getting to the west end of the terrace, you see the mansion is there terminated by a conservatory. From this, as well as the rooms with which it communicates, a pretty vista is formed, through the opened doors in the divisions of the kitchen-garden. Between them and the conservatory is a wide grass drive, and a beautiful flower-garden, the beds having stone edgings, and the walks of gravel. The south wall, which bounds it to the north, is covered with interesting plants, such as the *Ceanothus azureus*, and the finer *Tea Roses*. The east wall already alluded to, in connection with the Azalea, along with other things, has one of the finest plants of the old *yellow Rose* in the country. I mentioned more than a twelvemonth ago, how fine the Geranium beds, &c., were in this garden.

Of the kitchen-garden I must not speak. I cannot think where I should begin and stop my pencil-marks. If not the best, it is one of the very best kitchen-gardens in England. Its extent is somewhere about five acres, and nicely divided by intersecting walls. The soil is for the most part artificial; Mr. Snow having received something like *carte blanche* to take soil wherever he could find it. The staple, therefore, varies according to the purpose wanted, but chiefly consists of a deep, rich, sandy loam, resting upon gravel. This, and being so fully protected, makes the garden a very early one. All sorts of fruits and vegetables thrive well. In the middle of one of the divisions is the chief range of houses: a plant-stove in the centre, with vineries and peach-house on the sides. In this stove, in addition to many good things, there is a fine collection of the Amaryllis group, most of them hybrids of Mr. Snow's raising. The Vines are very luxuriant. The Peaches have been seen at the Metropolitan exhibitions.

The division of the garden next Mr. Snow's dwelling is none the least interesting. In some particular borders near the house are beautiful old, but rare, herbaceous and bulbous plants. The centre part is chiefly occupied as the pit and frame ground, and here such crops as Sea-kale, Rhubarb, &c., are grown. On the south side, overshadowed by trees, is the fruit-room, a long building, perfectly dry, with double or hollow walls, double roof, means of giving air and letting off vapour at pleasure, a pattern that would please even our friend Mr. Errington, and the excellency of which has been proved in the fine fruit that Mr. Snow has shown for years at the early Metropolitan exhibitions. But in this division, besides some small Fig and Peach-houses, there is a range of small lean-to houses, near Mr. Snow's dwelling, on the east side of the west boundary wall. Here there is always something *nice* to be seen; and among other things, a fine collection of the *Gladioli* group; but what I mention them particularly for, is to remind amateurs that these are the houses I have some time ago chronicled for being heated so economically by small narrow flues underneath the paved floor.

I had no thought of making these dottings until I had finished the few words on the Azalea. If I had possessed notes, or told Mr. Snow of my intention, they might have been more interesting. But that may yet be mended. I forgot to say that the walks in the

kitchen-garden are mostly, and all will be, edged with slate; the gravel is firm and clean. One characteristic of the place is the *neatness ever apparent*, owing partly, no doubt, to the necessary supply of labour; but partly, also, to the innate sense of the neat and the beautiful, and a thorough enthusiasm for his profession, which must be accorded to the respected superintendent.

R. FISH.

JOTTINGS BY THE WAY.

(Concluded from page 106.)

NORTHAMPTON.—Close to the town there are two somewhat extensive nurseries, both well kept, and full of excellent stock, especially of hardy Coniferae, hardy ornamental shrubs and fruit-trees. The oldest one is now occupied by Messrs. Jeyes and Co. In front of one of the hothouses I observed a very fine *Juniperus excelsa*, fully fifteen feet high, and a very unique specimen. In the flower department, I saw several plants in bloom of a tall *Lobelia*, named *Queen Victoria*, one of the best of its tribe. The petals are so broad that they almost touch each other, and the colour a rich scarlet-crimson. I was so much pleased with it, that I purchased some for the purpose of hybridizing. It is a variety that every grower of such things should procure.

The owner of the other nursery is Mr. John Perkins. In it I observed a fine stock of trained Peaches, Nectarines, and other wall-fruit. In both nurseries there were some fine specimens of the best of the *Arbor vite*; the one commonly called the Siberian variety (*Thuja Siberica*). This is hardier than the Chinese (*Thuja orientalis*), and more compact than the American (*Thuja occidentalis*), forming beautiful pyramidal-shaped bushes of a bright green colour all the year. In that pleasing property it far surpasses any other species of *Thuja*.

Courteen Hall, the residence of Sir Charles Wake, Bart.; Mr Gardiner is the gardener at this place. It was the last I called at, and I saw several things that pleased me much. The place is about three miles from the Blisworth Station, on the Great Northern Railway, and is situated in a well-wooded park, very much secluded from the rest of the world. It may be characterised by the term "quiet," in the most exclusive sense. The flower-garden is rather extensive, and well attended to. I was much gratified with what was to me quite a novelty. The flower-beds were circularly disposed, and in the centre of each bed were several *standard* Scarlet Geraniums in full flower. Just at that season, the end of August, the standard Roses were out of flower, the summer-bloomers being past their season, and the autumnals or perpetuals had not come into bloom, but the standard Scarlet Geraniums were fine objects, and made a bright display of rich scarlet, causing no regret for the absence of Roses in bloom. Mr. Gardiner informed me that he first raises young plants, trains them up in pots, dressing off all the side-shoots till they attain the requisite height (four feet) before he allows them to make a head. He then plants them out in June, and they bloom till frost stops them. He then takes them up, pots them, and keeps them through the winter in some dry room till spring, then gently starts them into growth, and when the season returns replants them in the flower-garden. By this management they last several years. To prevent the winds from breaking off the side branches of the heads, he fixes a kind of ring or hoop to the stake that supports them, and fastens every shoot to this ring. I recommended the adoption of this method of growing Scarlet Geraniums, the effect is excellent.* Amongst

* The variety used for forming standards, is that known as *Mrs. Maylor*. What a fine one for that purpose Henderson's *Defiance* Scarlet Geranium would be!

the standard Geraniums I noticed a fine plant or two of *Cassia corymbosa* grown also as standards. This species is neither so well known, nor so much cultivated as an ornament to the flower-garden, as it deserves. Its bright green handsome foliage, and fine golden-coloured flowers, which are produced for a long season, render it very attractive. My able coadjutor, Mr. Beaton, recommends it, and from what I saw at Courteen Hall, I can confidently recommend it also, and in addition to its good properties as a low bedding-out plant, it forms a very ornamental standard, the colour of its flowers being very striking in contrast with the Scarlet Geraniums. Here, also, I noted some beds of the *Zelinda* Dahlia, not more than a foot high, and covered with its purple blossoms. Mr. Beaton would have been in raptures with them. Surely every cultivator of flowers in masses will try a bed or two of this showy, useful plant next year. Sir Joseph Paxton, amongst his 50,000 Scarlet Geraniums in the grounds of the Park at Sydenham, should have some thousands of this showy Dahlia, as an agreeable relief to the glowing colours of *Tom Thumb*, or his *master* either. No doubt he will, and thus bring this fine purple-bedder into public notice.

In the pleasure ground at Courteen Hall there are a few thriving Coniferæ, especially a fast-grown *Pinus insignis*, planted only in 1846, six years ago. It had attained, in that short time, the height of eighteen feet, with a stem as straight as an arrow, and regularly furnished with branches down to the ground. A more unique specimen of its kind does not exist in the kingdom.

This concludes my "Jottings by the Way." I trust, the few cultural hints, scattered, perhaps, too thinly, through them, will be found useful to many. I have yet in reserve a few notes on the *Bagshot Nurseries*, which I took on a recent visit to these celebrated stores of Coniferæ and American plants, on which I may scribble a paper by-and-by.

T. APPLEBY.

THE PETUNIA.

(Continued from page 127.)

Summer Treatment.—The season for this work commences in early spring. I shall suppose a plant to be in a 60-pot, and has passed through winter unscathed. It should be a low, bushy plant, well furnished with branches and healthy leaves. The soil, as directed in my last, should be duly prepared sometime previous, and a sufficient portion placed under cover to become partially dry. A good method to know when the soil or compost is in right condition, is to take up a handful, press it gently, and let it fall upon the bench; if it break into pieces it is fit for use, but if it clings together, it is a sign that it requires more time to dry. I do not approve of *quick drying*, by laying upon flues, for that method drives off the nutritious gases contained in the compost. Let it dry gradually, and, as it were, naturally, and then these gases are preserved. The soil being in suitable condition, let the plants be brought out of the greenhouse to the bench, and prepare the pots to receive them. If old and dirty, let them be clean-washed, and do not use them till they are perfectly dry; then drain them well in the usual way; place some rough siftings over the drainage and upon them place as much soil as will raise the ball of earth the plants are growing in to the level of the rim of the new pots; then turn the plants in succession out of the pots; remove carefully the drainage that may be attached to each ball without injuring the roots; place the plant in the fresh pot, and fill round the ball the new compost till the pot is full; then give a gentle stroke upon the

bench to settle the plants and new earth, and fill up the deficiency; the old ball should then be covered about half-an-inch, and a small space left below the level of the rim to contain water. Proceed thus till all the plants are finished, and then give a gentle watering, and the operation is complete. Return them to the greenhouse, and, if possible, place them close to the glass. As they grow, take care to stop each shoot, to cause more shoots to be produced, and thereby induce a bushy habit. The tops, if required, may be made use of as cuttings. In this stage the plants will require constant attention to keep them duly supplied with water, and plenty of air whenever the weather is mild; and this treatment suits most of the inhabitants of the greenhouse which is so far fortunate for the Petunia. About the middle of April, if all has gone on favourably, they will require a second shift into larger pots, into the same compost, using the same precautions as to drying the soil, draining the pots, and so forth. Most probably the green fly will now make its appearance, and must be instantly checked and destroyed by frequent fumigations of tobacco. It would be an advantage, when the weather becomes warmer, to place the plants in a cold frame or pit, upon a layer of coal ashes. There they will grow much stronger and more bushy than on the greenhouse stage or platform, and thus, as it were, lay in a stock of strength to produce a fine bloom. There is one disadvantage in placing these soft-leaved plants in such a situation, and that is, the mildew sometimes makes its appearance on the leaves. The best remedy I have found for this disease is a dusting of sulphur upon the leaves affected, and a large admission of fresh air on mild dry days. If a weak solution of liquid manure be given to all otherwise healthy plants, more vigour will be given to the system of each, and they will, with the addition of the sulphur, soon grow out of the disease. A third and last shift will be necessary in June; the plants should then be put into pots nine inches in diameter, and in these they are to flower. As soon as the usual inhabitants of the greenhouse are removed into their summer quarters, the Petunias will be in a fit state to take their place. Plenty of air must be given and the roof should be shaded with canvass bunting whenever the sun shines brightly. There, along with Fuchsias, and other summer-flowering plants, they will produce a splendid bloom of fine flowers for two or three months.

Winter Treatment.—As the Petunia is little more than an annual, old plants that have flowered freely through the summer will be so exhausted that it is hardly worth while to keep them through winter; but for scarce kinds or seedlings a winter treatment is requisite. Let such be cut down early in August, leaving all the young shoots that are near the soil; take them to the potting bench, turn them out of their blooming pots, reduce the ball pretty freely, so as to enable the operator to repot them into five-inch pots, give no water, and place them either in a close pit or in a shady part of the greenhouse, where no air can blow upon or over them. Shade closely for a week or two till fresh growth is induced, then inure them gradually; stop the top shoots, and give a small watering. Keep them through the winter as close to the glass as possible, and rather dry than otherwise through that trying dreary season. If these plants can be preserved, they will make fine, strong, early-blooming plants the season following.

T. APPLEBY.

(To be concluded in our next.)

EARLY SEA-KALE AND EARLY RHUBARB.

DIFFERING from almost every thing else, *Sea-kale* is in higher estimation when in a forced state than when

produced under natural conditions. This difference, no doubt, arises from the more complete exclusion of the light and air in the former than is often done in the latter case, as well as in the more timely service it renders at Christmas than it could in May. Leaving, however, a part to furnish fine strong heads in the natural way when spring sets in, let us see what can be done to have some at Christmas, or before, as well as the remainder of the winter and early spring months. Now, to accomplish this no time must be lost; in fact, when this paper reaches the mass of south country readers who have large quantities of this to supply, some progress in the way of hastening it will have been made. Leaving these parties to follow out the practice which their experience has taught them to be most successful, the less-experienced would do well to look over his beds, and after noting down their capabilities and general qualifications, he will see at once which is best to force on the ground it occupies, and which ought to be taken up and hurried into use in some other medium. If the instructions given last year have been carried out there will be a certain breadth of roots prepared expressly for the latter purpose, which ought to be carefully looked to now, as they present the readiest, quickest, and most economical mode of obtaining early Kale. Supposing, therefore, that a quantity of seed had been sown early in spring on some well-prepared piece of ground, had been afterwards thinned, ground-stirred, and every other attention paid to it calculated to encourage its growth, it will by this time have attained a root equal in size with that of most ordinary carrots, and, of course, have formed its buds (which are, in the first year, only one to a plant,) with a degree of strength and plumpness without which it is useless to think of a successful issue, or, rather, it is impossible to obtain fine, strong heads, except from plants which have accumulated a large amount of vital energy in their embryo buds. There may be cases in which the latter produces only a weak, sickly after-growth; and in all cases the forced is below the natural strength in that respect, and, in some instances, goes so far as to present us with a sickly, weak growth from a bud apparently set with considerable vigour; but this anomaly is easily accounted for; the sacrifice it has been called on to make is such as some plants would not live under—let alone flourish. The period of rest so necessary to all vegetation is denied this altogether; and an amount of stimulating heat applied to this with a view to forward its utility—nay, even to drive or hurry it on to the utmost of its speed; it is, therefore, no wonder that it sometimes becomes sickly, and not unfrequently refuses to grow altogether; it is, therefore, imperative on all those who wish to have this production as early as possible, and in good condition, to give it all the advantages that can tend to that result, and, of course, avoid all those evils having a contrary tendency.

Now it is well known that a considerable sacrifice has to be made in all produce hastened to a premature ripeness; and this sacrifice, like many others, differs in the degree of forcible means used; a short period of rest, followed by a gentle heat, gradually applied, is more likely to result in a successful issue, than an application of a moist heat applied to plants whose summer growth has hardly yet ripened. The weary traveller does not like to be roused again into action ere he has retired to rest at all; neither does vegetation, even of the most robust kind, of which Sea-kale is a very good example, as a less hardy plant would be killed outright with one-half of the ill-treatment this is often subjected to. Yet this one has its point of endurance, beyond which it is impossible to go without endangering its existence. Now these dangers are more numerous in the early part of the season than later on; the same amount of trial and hardship that would

produce excellent Kale in February, would either kill plants in December, or only produce a sickly growth at that untoward season. Yet Sea-kale is wanted at both these seasons. Greater care must, therefore, be exercised in the earlier crops, and the plants may be coaxed into producing fair, good, average-sized heads, when everything is supplied them necessary to their wants, and stimulation applied no further than is consistent with their well-doing. In this respect much judgment is required; the plant which, if left until March, could and would endure almost any amount of heat, languishes and dies now, when subjected to only moderate changes of temperature; it must, therefore, be reduced so low, as only to forward vegetation by those gradual means to which alone it is susceptible at this season. The best way to accomplish this, is to have the plants in a medium, over which a perfect command of heat may be attained. When forcing by fire-heat is going on in another department, there is often some odd corner contiguous to the fire-place where a deep box or two might be placed, to be filled with the roots of this plant, then to be afterwards covered with another box inverted over them, and some means taken to keep the atmosphere they are growing in as moist as possible.

A mushroom-house is also a very appropriate place for early Kale, where a shelf or bin may be filled with the roots, placed a few inches apart, and fine soil run in amongst them, with an inch or so of sand or coal-ashes at top. One or two waterings with tepid manure-water will be of service after they have started growth, or even before, if the plant be at all subjected to the drying effects of fire-heat; but either in this case or any other where the plants are so treated, a certain amount of moisture must surround the young shoots, or they will be tough, and not good. Now, if this be difficult to command at all times, it would be better to cover the plants slightly with a something to which moisture may be applied when necessary; moss or litter dipped in hot-water, to which a little salt has been added to kill all insects, will do very well; or it may be that a covering of coal-ashes may be applied, which may be put on so gradually as only to keep the shoots covered as they advance into growth; this, of course, will be best known by occasional examinations, and, with ordinary care, this way Sea-kale of good quality has been produced under circumstances of a very homely and makeshift kind, which every one is obliged to adopt in something or other. And if the amateur, whose means are only limited, be anxious to have Sea-kale at his Christmas dinner, he may certainly accomplish this yet by the means noted above, or he may even produce it by the ordinary method of covering it up on the ground where growing with gentle heating material, of which leaves are the best, and the result in the latter case will be equally good as the former, only not so quick; and when any other heating material than leaves is used, much uncertainty exists as to its overheating, and other contingencies which it is difficult to guard against. The only counter-benefits of the plan is, the little injury its roots derive, compared with those that are taken up and unavoidably mutilated; but the latter should be done as carefully as possible, in order to give the plant every encouragement compatible with the circumstances of its case. Plants, or, rather roots, carelessly taken up, half-broken and otherwise mutilated or deprived of one-half their supplying feeders to the crown of the plant, can hardly be expected to produce heads of any consequence. We, therefore, strongly urge on the amateur to take especial care of this; and in putting them into their forcing quarters not to crowd and injure them to an unreasonable extent, otherwise the produce cannot be expected to be satisfactory.

Although I have not mentioned *Rhubarb* in this article, yet it may be subjected to a similar mode of

treatment to that given for Sea-kale. A few old plants, taken up and planted out in some heated situation, will produce fine useful stalks some time before that growing in the open ground can be urged into action. The deep roots of this plant extending beyond the depth of the heat applied, render its progress more slow than Sea-kale; thus, in most cases, a few roots taken up in November, and put into some warm corner, will produce stalks long before that in open ground, although covered up. So that for all purposes, where an early supply is wanted, the quantity put in as above is attended with better results. It is almost needless to observe, that a well-prepared hot-bed, or one that can be heated by linings, &c., will answer the purpose for Sea-kale, Asparagus, and Rhubarb; but as frames may be all otherwise engaged, a less troublesome mode may serve the first and last of them. *Asparagus* must be accommodated with a frame and hot-bed, as it is important to allow it light prior to its being cut for use. But more of this anon.

J. ROBSON.

FLOWER-GARDEN PLANS. No. II.

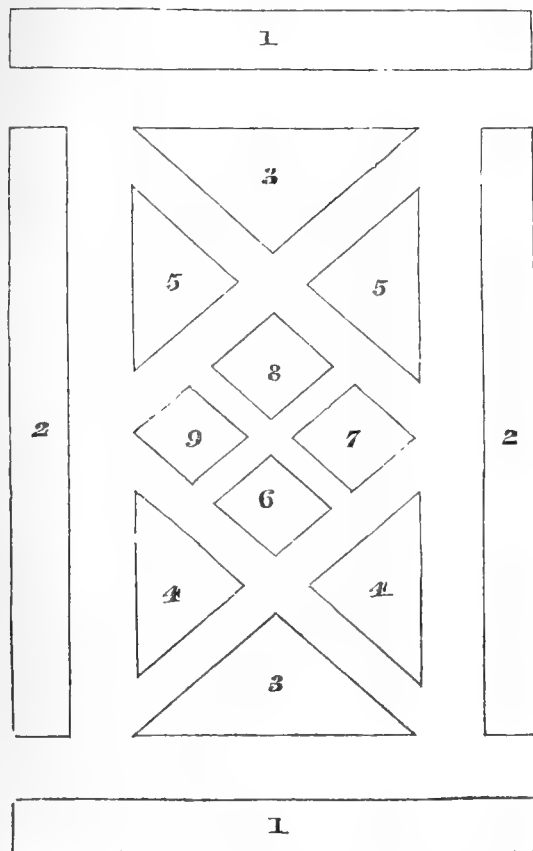

THIS plan was only sent to us this week; but it is so appropriate for what a large class of our readers, in the vicinity of large towns, have been asking for, that I made choice of it in preference to another plan I had ready, but for a different class of subscribers.

I had a very sensible letter the other day from "Grumbler"—the last word in our language that I would use for a signature—in which he urged the great demand that is now made for such plans as are suitable for "block buildings," of which there are three hundred now in his own neighbourhood, not far from London, ready to be laid out. Block buildings, it may be necessary to tell our country cousins, are merely the ordinary villas, or suburban retreats; or, if you like it better, the "country houses" of nine-tenths of our great city chieftains, as they would say in the Highlands; every trade and calling having its own chief or chieftains, and among the rest of them our own correspondent, the "Grumbler." Why such villas, &c., are called "block

buildings," is best known to the speculative builder himself. He buys a field one hundred feet wide along a main road, and two hundred feet the other way; he runs a fence down the middle of it, and each division he calls a "block" of fifty feet. In the centre of each block, and twenty feet from the road, he builds a handsome villa, and sells the two to get some money to enable him to buy or lease a larger "field" next time.

Here, then, we have two chieftains and four gardens—two back and two front ones. The front garden is twenty feet one way, and fifty feet the contrary way. The back garden may be about one hundred feet; so that each block needs two plans; a plan for the front garden next the road, and another for the back, for flowers and vegetables, and "all manner of things." The all manner of things are already on the place, standing bolt upright and as green as leeks; the block builder took care of all that to make the best of his bargain; and here we are in a great bustle to put all things straight.

To make anything of a country life we must have flowers, and to show them off to the best advantage we must have "plans;" and while Mr. Robson is working in the back ground, preparing for getting vegetables "fresh and fresh like," here is our No. 2 plan for the front flower-garden, or for the front part of the back garden; and it is the very thing for such places.

Our worthy friend who kindly took the trouble, for the use of our new settlers, remarked, "notwithstanding its simplicity, I venture to send the inclosed plan, as I have a small flower-garden so laid out which looks exceedingly well. The beds are confined by box edgings, and being near the sea-side the walks are covered with shell-gravel." These are the "white shells" which Mr. Robson recommends for the surface-coat of his new walks (page 108), and capital things they are. They are as brittle as egg-shells, and crumble under the tread like "short cake" under the double teeth of a school-boy coming home from a country fair. The best use I ever saw made of these shells was one day last summer, on the spur of the moment. It was at one of the flower-shows at the Regent's Park. Her Majesty was expected, and the ground was soapy under the tents with so much rain, so, instead of laying crimson cloth all over the paths, as they usually do at the entrance when they expect the Queen, what did Mr. Marnock do but set a whole lot of able fellows with large bags of these shells, to strew them along the paths right round the tents, and they scattered them with their hands, just as Anster Bonn would deal out so much barley to a covey of the true Shanghai breed. In less than ten minutes the royal suite passed along, as dry and comfortable as any of you could wish. After seeing all this, and knowing my relish for comfortable walks, you will not be surprised to hear me chime in with Mr. Robson, "I would strongly advocate the use of shells to all who are within reach of them."

After plans for villa gardens, the next greatest demand has been for how to get the best contrivance for disposing of a collection of herbaceous plants, and how herbaceous plants might be made to do the work of bedding plants, for which sufficient accommodation could not be procured; and, last of all, the best shape for a flower-bed has been asked for. Now, it is certain that all these points depend entirely on taste; yea, what we call the *principle* of planting, whether it be flower-beds, cabbage-plots, plantations, or park scenery, is no *principle* at all, if we except the proper distances and soils for the different things we plant; all the rest is, as it ought to be, governed by taste. Therefore, how is it possible that one generation can lay down rules of taste for the next generation, or be itself governed by that of the past? It is just the same with individuals; and an individual who aspires to lead the public in any branches of taste, or branches governed by taste, ought to show no *particular* taste of his own, farther than that certain means are better for certain ends than others; anything beyond this narrows the channel through which taste flows, according to the influence of the leader. If THE COTTAGE GARDENER were to take up a certain notion, and say that such-and-such was the most tasteful way of arranging a garden, it has influence enough to do a vast extent of injury, by thus contracting the means of improvement. Let individual taste, therefore, have full play only in private, and it will soon improve on

itself. Let it send the results of its experiments, from time to time, to the full glare of light in these pages, and all will strive to follow, and some will endeavour to improve still further, and thus improvements *would* go on uninterruptedly, were it not for the misfortune that a book or an essay appears now and then, in which the author strongly advises the subject of his tale to be carried on according to some improvements which *he* has effected, or thought upon, to the exclusion of all others! Instead of being leaders, such authors ought to be pilloried, as a warning to the public against trusting to such dealers in universal medicines.

This is my second and last preface on the subject. I laid the substance of the two before the Editor, at first starting, in quite another form, but he would not hear of my plan. He told me, in effect, you must tell your tale yourself, in the best way you can, and that is all about it. Now, I hope I have done so sufficiently to be understood. In future, I shall be like Bailie Nicol Jarvie, in Rob Roy—"A Bailie," "a magistrate," and "a free-born citizen," sitting, not in judgment on the different styles of tastes in laying out flower-gardens, but to give a fair hearing and a suitable introduction to all styles and plans that are sent to me; so that we may all learn and improve as we go on.

The plan before us is very accommodating; it may stand either in the front of a villa, next the road, or nearest the country. The front-door, or the centre of the house, may be opposite 1-1, or opposite 2-2; or it may be a distinct feature in a part away from the house. 1-1 and 2-2 would be one of the best arrangements for "herbaceous plants," and the middle figures for gay bedders. Or if the house stood behind 1, the opposite 1 might be of Dahlias, or with Dahlias and a row of the best Hollyhocks behind them. The same with the 2. 2. No one can go up straight to the middle of this garden; and this is always a wise arrangement, particularly in plans of limited extent. Again, 1-1 and 2-2 might be made the "Rosary," surrounding the flower-garden, with rose-arches thrown over the four corners; and if so, pillar-roses, or high standards, ought to run along the centres of each long bed. Those who object to tall standards, and I am one of them, would have pillar-roses about seven feet high, or height of the rose-arches, and festoons from pillar to pillar, and joining the arches. For any of these suggestions, the long beds would need to be at least six feet wide, and eight feet would be better, particularly for the roses, as we must suppose a good pillar-rose to be at least two feet through at the bottom, and the festoons will need as much room as the bottom of the pillars, to allow them to swing about with the wind. Then with an eight-foot bed we have only room for three rows of dwarf-roses on each side of these beds, and hardly that. Once more, if these long beds were only three or four feet wide, and raised six inches above the general level, filled as Mr. Appleby says for florists' flowers; the best late Tulips would do in the one farthest from the house; the best *Early Tulips*, being dwarfier and earlier, next the house; and the side ones with Hyacinths, bordered with Turban or some common Ranunculus. In the summer, all the long beds, being planted with Roses, might be edged with the white *Campanula pumila* at six inches from the sides, or the white *C. carpatica* at nine inches. The plants standing nearly close to each other in the row. Last of all, the two No. 1 beds might be planted with Mayles's *Variiegated Geranium*, and *Beauty supreme* Verbena, plant for plant; or the one next the house this way, and the opposite a shot-silk bed, with *Verbena venosa*, and the old *variegated Scarlet Geranium*. For the middle beds 3-3 ought to have plants a little taller than 4-4 and 5-5, and the dwarfest plants to occupy the four centre beds. If the front door, or the drawing-room window stood opposite 2, then 4 and 5 ought to be of one colour, and if a different plant is used for each, their heights and way of growth ought to be as much alike as possible. The same colours should be repeated in the opposite 4 and 5; the plants either straight across or corner-wise—that is, the plant in 4 to be repeated in the 5 at the opposite corner, or just across in the other 4. On the other hand, if the door or window is opposite 1, then 4-4 should be of the same height and colour, and 5-5 may be of quite a different colour, and the plants a little higher than in 4-4, as they are farther from the eye. For the same reason, the colour in 5-5 should be brighter, or more telling. If 1 is

of the variegated *Geranium* and Pink *Verbena*, we have a strong pink on a white ground; and no blue, lilac, purple, or white should stand in 3 in front of it. I would put the *Kentish Hero* *Calceolaria* in this 3, and a bright-yellow *Calceolaria* in the opposite 3. I would plant 5-5 with two good purples, or light rose-coloured Verbenas or Petunias, and 4-4 with pink or dark-bluish flowers; or, say the right-hand 5 was full of *Shrubland-rose* Petunias, and the left-hand 4 with *Saponaria calabrica*, then the right-hand 4 with pink Ivy-leaved *Geranium*, and the left hand 5 with *Petunia Devoniensis*. But any other plants coming near to these sizes and colours would do just as well. It is the firm opinion of the best planters, however, that matching the height of plants is as essential as the disposition of the colours, if not more so. Also, to suit the height to the size of a bed is of first importance: thus, a circle ten feet in diameter, quite flat, and planted with *Tom-Thumb* *Geraniums*, all of one size and age, though brilliant in the extreme, would still be "bald, like a cat's face," in the eyes of an artist, as I once heard Sir Charles Barry remarking to another great artist, speaking of a great building. The same *Tom-Thumbs*, planted in a circle not more than four or five feet through, would make a gem, and a person who did not know on what part of the body gems are worn, would be just as likely to wear one across the bridge of the nose as anywhere else; and it is as essential in placing heights and colours in flower-gardens.

We have still four beds in the centre of our plan, and if you keep in mind what is said of fitting the height of a plant to the size of the bed, if you never planted a bed before, you can plant these four just as well as any of us. We have got the plants and colours so disposed of in the rest of the plan that you cannot possibly mar the effect or add much to it. I would plant the four beds with scarlet and white—either Verbenas or *Geraniums*—or with four shades, as *Lady Mary Fox*, *Diadematum rubescens*, *Quercifolium coccinea*, and old *Diadematum*. Or, I would keep them for any of whatever were my pet plants, as no colour will much affect that part of the garden. The little blue *Lobelia* and yellow *Oenothera prostrata* would do there. All the beds might be large enough to allow these centre ones, in proportion, to be three feet on the sides; in that case, two of them with *Saponaria calabrica*, the other two of *Sanvitalia procumbens*, would look very well indeed; but then there should be none of the *Saponaria* in the plan. After all this, there are ten other different ways to manage this plan equally well.

D. BEATON.

ALLOTMENT FARMING.—DECEMBER.

Frosty, dark December! the very sound of this month is but too apt to engender in the sons of the soil apathetic feelings. The iron rule of the Ice king, the investment of the earth's surface with a mantle of snow, or, what is generally the alternative, sleety, drizzling rains, turning midday into a kind of twilight, appear to furnish a solid excuse for a total neglect of the soil. And, indeed, either of these conditions, whilst it lasts, is a serious impediment to garden operations. Still, let not any man fancy that the smell, by anticipation, of the Christmas pudding, can alone furnish a thorough excuse for hanging up the spade and mattock to rest for a month or two. Of course, the ordinary labourer has no overplus time to spare from his regular employ, which, after all, is the main thing, and to which all other things must give place. He may be, which we hope he is, in full employ, his services regularly required by his master. But most employers will grant a day by chance for a special matter, the thing properly explained. If we were to seek for a fault in the allotment system, as connected with our agrarian population, it would be where too much temptation exists to absent themselves from their regular employ; in consequence of which a host of ill-feelings sometimes arise. The winter has been, perhaps, an unusually protracted one, or the early spring months excessively wet; at last a favourable period arrives for working the soil; the employer is all on tip-toe, of course, for he has a rent to pay, and a living to make. Well, the very approach of fine weather and long days is the signal for the labourer to begin a spring career on his plot, and if

that plot is nearly a statute acre—as is frequently the case in some districts—there is too often an end of all comfort between the employer and employed. We do not say that such cases are the rule; the exception they are and need be; but when they do occur they are not a whit less a grievance. The only cure for all this is with those who grant allotment plots, to take care that they are not sufficiently large to draw the holder away from his ordinary duties. By experience, we are assured that half-an-acre is too much, and we should suggest a quarter, as well meeting the average of cases. But, perhaps, these remarks apply more to the holders of cottages, to which land has long been attached; with these we have had *much to do* during the last twenty years as labourers under our superintendence, and can bear ample testimony to the asperity of feelings induced by having labourers who would be ever at their post in the short or bad days, and off without notice on the first fine day, when real business might be advantageously carried out. But now for the business of the allotment or cottage gardener, for our duties lie with both.

First of all, we will ask, Is the land *ridged* from which crops have been totally removed, and which is liable to be soured by rain or snow? That is to say, is it piled up to mellow by the winter's frosts, and to drain from the winter's snow? If not, you have omitted a most necessary proceeding, which we assuredly have not omitted to advise in former papers.

In order to save repetition, we beg to refer the attentive reader to page 65, on the improvement of the staple, and pass on to think about rotations for the ensuing year; for we will try and persuade every one of our allotment friends, yea, and cottage gardeners too, to spend the dull evenings, which are not only approaching, but at our threshold, in conning over the various modes or schemes of cropping, by which a *profit* may be realised, and the domestic comforts of the family increased. Those who may feel thus inclined, may refer to many back allotment papers for suggestions, and we will here again offer the results of many considerations of this question, carried on for some years, in which, according to one of our fine writers, we have endeavoured to "make each day a critic on the last."

We do take it for granted that the production of *keeping roots* is the chief basis on which allotment cropping ought to rest, and that all mixed cropping ought to be held subordinate to this principle. Of course, if no pig is kept, it materially alters the question; and if *both* cow and pigs, more so still. The latter being quite the exception, we have, in general, paid less attention to it; but as to a pig alone, that constitutes, doubtless, the majority of cases.

In connection with this view of the case, we hold another maxim—viz., that deep digging or trenching ought to be had recourse to every third year. Such being admitted, it becomes a consideration what class of crops to trench for. As to the benefits derivable from trenching, it is to be hoped that to the minds of many of our readers they are quite familiar; to others we say, that all crops with which we are acquainted, unless of a very stubborn character, enjoy a taste of the subsoil, which appears to contain certain inorganic matters of importance to most crops. This, however, is not all—depth of root to crops that have to undergo culture a whole summer and autumn is of immense importance. Two plots of the *Swede Turnip* shall stand side by side, the soil equal in quality, and in the same condition as to previous cropping. No. 1 shall be trenched two feet deep, using the manure between the spits; No. 2 shall be dug the depth of a half-worn spade, which we will call seven inches, and the same amount of manure dug in. And now we will suppose a hot and dry time in August. The almost certain result would be, that No. 2 will grow with more rapidity, if showery weather, for the first month; but as soon as overtaken by drought it will become stationary, and not only that, but mildewed. The greater expanse of foliage will only subject them to a higher amount of elaboration when the drought comes, and if they cannot extend their fibres in a degree commensurate with the drought in their foliage, they begin to flag, and this flagging indicates the condition of sap requisite to encourage the mildew. By this time, No. 1 shall be striking downwards, and shall have fibres more than a foot in depth, where there is a permanency of moisture, whilst No. 2 has four-fifths of its

fibres in mere dust. Thus stands the case with most crops that we have experimented on; and we boldly affirm that the case is in no way overcharged. The destruction of weeds, insects, &c., although we hold it to be a subordinate consideration, is by no means unimportant; and thus, altogether, surely a case is made out for a periodical trenching.

For general purposes, we do think that the crops for an allotment may be placed in three equal divisions, under the heads—Roots, Miscellaneous Crops, Potatoes. Now, although it is not intended *rigidly* to enforce so *very distinct* a separation of objects, yet, on the whole, we would adhere to it as a maxim, and, above all, take it as a guiding principle annually, as the allotment planning came round. This will keep the cultivator from confusion, and by it, if tolerably well adhered to, he will always be in a position to know the past history of his plots and prospective hopes. These things being settled, mixed or "stolen crops" may be so woven in with the system, as not to derange the main plan; and this must be from a full consideration of the habits and periods of the principal crops.

Although *Potatoes* may be fairly classed among the root-crops, yet in this we would keep them separate; they require separate culture in these days, and, moreover, by separating them the chief of the remaining root-crops will be the deep-rooted or fusiform class, for which depth is particularly essential. This brings us to our point: the ground in three divisions, one division trenched annually, and that for the root-crops.

Now these root-crops, under such circumstances, we would term renewal-crops, or renovators—not that they detract less from the soil than others, but that extra depth and extra culture leaves the land in first-rate order for other successions. They will prove excellent preparers for either Potatoes or the Miscellaneous section; but where many of the Cabbageworts are grown, we should prefer following them with Potatoes, without a particle of manure, presuming the ground to have been liberally treated for the Cabbageworts. We have no more space for rotation affairs, and now beg of our little gardeners to study this matter during these long evenings, and to lay on the fire an extra log, for the wind begins to whistle through every cranny. When they have once decided, let them get a stick or two, shave one end flat for writing on, get a little thick white paint, which rub thinly on the writing part, and *immediately* write the name of the crop; if succeeded by anything, or to receive a "stolen crop," with the circumstances of manuring, digging, &c.

Thus—"Broad Beans sown early in February, rows three feet; Kale planted between, sown March. Beans succeeded by Cabbageworts, or Coleworts, sown middle of June; lightly manured, and dug in end of November into ridges; ridges levelled down in beginning of February." We have written in full, but an ingenious mind will soon make short work of this by a system of abbreviations, or substituting signs or marks for words. Thus, sown may be represented thus, . . . ; planting thus, T representing a dibble, commonly called a "dibber;" the months by first and last letter—thus, My, May, Jy, July, and so on. Even the digging and trenching may stand thus, 1, 2, the one single, the other double digging; and the period of the month by b, m, e., signifying beginning, middle, and end. We now take leave of this portion, having "broken the ice" fairly.

Priming for Spring Crops.—Let not our friends despise the soot of their chimneys, but hoard it up for mixtures to drill with; this we call priming. Such, mixed in spring with burnt or charred rubbish, and the residue of old manure heaps, old leaf or vegetable soil, and a little of Messrs. Gibbs' Peruvian Guano, all well blended, will soon set your young plants on their legs.

Ditches and Fences.—If your allotment or garden has anything of this kind, pray do not delay till the spring, if you can possibly carry anything out. Experience tells us, that spring, if fairly personified by the painter, might come in the shape of a young, strong, and raw, broad-shouldered fellow; but of what use is it having broad shoulders, if they are compelled to do double duty. If his sage old parent, winter, has been a far-seeing old gentleman, and has cunningly had a portion of the burdens destined for the young squires shouldering got rid of before-hand, why all we can say is—a wise sire, and a lucky youth. But joking will not

do; and we say, at least clear out water courses, mouths of drains, or anything else that tells of a stagnation; in fact, any boundary matter also; and if scourings, dubbings, ditchings, or any bulky vegetable matter comes to hand, pray secure it; try to mellow, and to decompose it.

In conclusion, we advise, make up your *rotations* betimes; proceed with not only improvements where possible, but necessary business, ridging and digging, if feasible, for early spring cropping. And, above all, look to your manure-heaps; if not yet wanted, throw them up into steep conical heaps, in order to keep the rain out. If any one doubts the effects of much rain on a heap of muck, let him look at the colour of the water in the nearest ditch below the muck heap, or watch his wife's teapot.

R. ERRINGTON.

THE APIARIAN'S CALENDAR.—DECEMBER.

By J. H. Payne, Esq., Author of "The Bee-Keeper's Guide," &c.

ANSWERS TO MANY QUESTIONS.—Numerous have been the questions to me of late: "What am I to do with my weak stocks; how can I keep them through the winter?" To all I would say, as I have already repeatedly done, *feed them well*, in the manner already directed in the pages of THE COTTAGE GARDENER, and you may keep them through the winter.

ENEMIES.—Guard well against birds and mice; except a vigilant eye is kept upon these, sad inroads may be made amongst your stocks, especially in exposed situations, and at this season they are most to be feared.

VENTILATION.—Look well to this matter for the next two months, where the bees are in boxes or straw hives with wood tops; hives entirely of straw will not require it. A small opening at the top of each box, with an inverted tumbler placed over it, will be sufficient.

FLOOR-BOARDS.—Give the floor-boards a cleaning, and, at the same time, see that the hives have not suffered from the late unusually heavy rains. Freeness from damp is essential to their prosperity, for with it the richest stocks are sometimes destroyed.

SNOW.—Be particularly careful to shut up during the time that snow lies upon the ground, for when the sun shines upon the hives at that time the bees are induced to come out, when numbers perish, by which the hives are much depopulated.

DRIVING BEES.—Thanks are due to "Investigator" for his paper in THE COTTAGE GARDENER of the 11th instant. I willingly tender him mine; many practical hints may be gathered from it, even by those who are far away from the "Moors."

ERRATUM.—In my last Calendar, in Mr. Taylor's letter, for *working* read *making*.

COST OF KEEPING SHANGHAE FOWLS.

ALTHOUGH, Sir, I am, with yourself, very willing to credit the accuracy of "Gallus's" report of his experiments on feeding, and feel, as must all interested in the subject, much indebted to him for the trouble he has taken in the matter, I must, for one, confess that I am very far from thinking those experiments conclusive on the points attempted to be definitively settled by them—namely, as either showing that the Cochinchina breed are larger consumers of food than either the Spanish or the Dorking; or, supposing this to be so, as proving that, therefore, the former is a less profitable breed for the cottager than either of the latter. I think, indeed, that very few of your unprejudiced or disinterested readers will be inclined to admit that those trials, opposed as they are in their results to the experience of so many equally reliable authorities, are of so satisfactory a nature as to justify "Gallus's" opinion of them—that they will of themselves suffice to plead the cause he has undertaken; and, with your permission, I will endeavour to point out in what particulars they appear to me wholly unsatisfactory. First, then, and in addition to the exceptions taken by you, I altogether object to *chickens*, or any but full-grown birds, forming part of experiments made to ascertain the points in question. It will hardly be maintained by Anster Bonn,

or any other champion of the large breed, that birds which, when full-grown, weigh as much as twelve pounds, will require no more food to bring them to maturity than others which, when full-grown, only attain half that weight, which is not far from the relative difference in the weights of Cochins, on the one hand, and Spanish and Dorkings on the other; consequently, if the rapidity of growth is in all proportionate rates in the large and smaller breeds, it cannot but follow that chickens of the larger breed will consume most food. But it does not necessarily follow, as I will presently attempt to show, that the largest consumers of food, when chickens, are therefore the least remunerative breed to keep.

A less obvious, but not on that account a less valid objection to admitting any but full-grown birds into these experiments, is the fact, sufficiently notorious to observant amateurs, that at different and uncertain periods of their growth, chickens, particularly of the Shanghae breeds, increase in weight very much faster than at others (this is partly seen by a comparison of the weights in tables 3 of "Gallus's" experiments); and not unfrequently, after continuing for a time in a slowly-growing state, they will, with a sudden impetus as it were, "go ahead," and develop so rapidly in shape and size as in a few days almost to outgrow the recollection of the feeder. At such times their appetites are most voracious, and the amount of food consumed is in no proportion to what might have been a fair estimate of it before this impetus in growth set in. Hence, results derived from experiments with birds subject to such adventitious influences must be of questionable authority. These objections are, I think, insuperable to the conclusiveness of "Gallus's" experiments; but there are others which, though they may appear to some captious and trivial, to those who are aware of the difficulty of obtaining reliable results in all experiments on the feeding of animals, will of themselves be thought sufficient to preclude safe deductions being drawn from a consideration of the abstract results of these trials. Such are—the want of sameness in the condition of the old birds, some being in moult, some laying, and others not; the unequal advantages to which the different lots were subjected—one lot having the run of a large plantation and stubble field, and another access to a large grass field and plantation, while two more lots were confined to a wire cage, and occasionally fed with bread by children; apparently, too, some little difference in the description of food given to one or two lots, and a few days variation in the date of commencing the trial in lots 4,—none of them, perhaps, very important circumstances individually, but in the aggregate, and whether regarded as in favour or against any particular view of the subject, must, from the want of uniformity and precision in the details, militate against the accuracy of the results.

I suspect that the objectors to the Shanghae and Cochinchina breeds, on the score of their being such large consumers of food, have come to this conclusion from their experience of what the *young* birds of these breeds are capable of in this way, when contrasted with those of the smaller breeds; but surely this is an unfair comparison, unless the much greater weight of animal food obtained as an equivalent, and the rapidity with which that food is produced in the one case over the other, is also taken into account and compared. It is a well-known law in the economy of healthy-growing animals, that the great bulk of the nutriment of the food consumed, or all but a minute portion of it, is applied to build up the various textures of which the body is composed; and as in edible vegetables, so in the case of animals used as food—the more rapid the growth and formation of these textures the better will be the quality, the more delicate the consistence and flavour of the food so produced. Looking, therefore, at the "chicken" merely as a machine for the conversion of cheap materials into a costly article of animal food, the point to be considered by those who have this object in view, and would be guided by motives of economy in their selection is, not which machine will consume *least* of the raw material (for, in any case, the equivalent in the manufactured article will be in a fixed proportion to the amount of materials employed), but which will manufacture the article most expeditiously, and give the quickest return of serviceable food. Here, I think, it will not be questioned,

that the Cochin-China breed possesses this property in a pre-eminent degree—seeing that their chickens at four months old will outweigh those of Spanish or Dorking at six. And with regard to the quality of their flesh, the general opinion expressed by your correspondents is, I think, decisive that, although there exists as yet some little prejudice against the long legs and colour of the skin, they come behind no breed in the essentials which render this description of food so valuable an adjunct to the table. And, certainly, my own opinion, founded on pretty extensive trials in this agreeable particular, is not opposed to that conclusion.

Take, now, the other commodity, to the remunerative production of which the attention of the cottager would be more especially directed in forming his estimate of the most suitable breed, namely, "Eggs." In the full-grown laying hen, as in the growing chicken, only a very inconsiderable part of the nutriment, as compared with the whole extracted from the food eaten, is required to replace the loss occasioned by the waste which, to a certain extent, is continually going on in the bodies of all animals. By far the larger portion of it is diverted to supply the specific *drain* which is necessary to, and results in, the formation of the egg; and it will be found, with here and there perhaps an exception, that in proportion to the food consumed will be the fertility of the hen in her yield of eggs. So that here, again, if we regard the hen as an "egg-producing machine," the question of preference with the cottager ought to be—not which breed of hens are the smallest eaters (for the number of eggs laid being in the ratio of the food consumed, he will assuredly with small eaters also have but indifferent layers)—but, which breed will manufacture their food most expeditiously; which, in short, possesses the greatest egg-producing power, irrespective of the food consumed, which, however, will be a true reflex of that power. Now, my own opinion is, that nothing *can* excel the Cochin-China breeds in the number of eggs they produce. Spanish, I believe, may equal them in this respect, and even surpass them in weight of eggs, and though, the quality of the eggs being the same, I should esteem this an important point, it would be of little benefit to the cottager so long as eggs are sold by number and not weight. But the superior richness and flavour of the smaller egg will, I think, in the long run, prove more than a set-off against any deficiency in its size, for I am quite of opinion that when the breed becomes more general, this superiority will be so notorious as to enable them to command a better price than the eggs of any other breed, particularly in our large towns, where quality, in all that conduces to the gratification of the palate at least, is so well appreciated. Allowing, however, the merits of the two breeds *as layers* to be equal (I do not here include Dorkings, as from my experience of them they do not, as layers, merit a comparison, and this defect will, I think, partly account for their being, which they indisputably are, so excellent a fowl for the table), there remains one point, and to my thinking *only* one, on the question of the alleged greater cost of keeping Cochins over Spanish, and that is in the supposed case of a cottager who may have no market for his chickens, and whose sole object, therefore, in rearing poultry, would be for the profit of their eggs. Being told that both breeds are equally prolific layers, but that Cochins, from their quicker growth and greater size, were the most expensive to keep *as chickens*, unless he could dispose of them as such, he might not unreasonably ask whether there were any advantages in the large breed, over the small, which would compensate for this difference in the cost of keeping, prior to the period of laying. On this point your readers have had such ample means of forming an opinion, both from the excellent articles of Anster Bonn, and the interesting communications of so many able correspondents, that I am unwilling to say anything on the subject, further than that in my own opinion, *more* than an equivalent, for this small additional cost, will be found in the fact of the Cochins excelling, not only Spanish, but all other fowls, as far as I am conversant with them, as *winter layers*. A consideration of all others perhaps the most important to the cottager.—SHANGHAI MANDARIN.

HARDY HERBACEOUS LOBELIAS.

LOBELIA SYPHILITICA.—How rarely is this beautiful plant to be seen, in either a choice selection, or even in botanical collections, where anything and everything should be kept for the lovers of plants. Notwithstanding the fine high colours of the *Lobelia splendens* and *fulgens*, and their varieties, we think this much prettier, and very desirable to mix with them in a bed or border. Indeed, we think this the hardiest and handsomest of all of the upright-growing "Cardinal flowers." It rises from two to three feet high; the whole plant is of a pale green colour, and leafy from the root to the very tip of its flower-stems, and a profuse bloomer; its flowers are of a light-blue colour; indeed, the whole plant makes a very striking appearance in the flower-border at all seasons, for even its leafy crowns are always visible, forming evergreen bunches in the borders during winter. It is a native of Virginia, and was introduced to this country in 1665.

In order to keep it growing to perfection it should be taken up, divided, and replanted every year in the spring months. The soil cannot be too rich for it, and it should be planted in rather a cool situation. We always choose new spots for these plants every year in our borders, and take care to keep a number of plants, in particular of any choice kinds, well working up the natural soil, and adding to it a spade or two of turfy-loam and leaf mould in equal parts; then planting a compact bunch of the plant, and with the hand pressing the soil about it snug and firm. Its time of flowering is from August to October. Being anxious to have enough of it, we have often put a bit of it in the kitchen-garden, at the foot of some of the vegetable quarters, where rich enough is the soil, and which is a new place too to the plant. These make fine specimens to lift into pots, in September, to take to a Horticultural Exhibition. Sometimes we have turned this plant out again to take its course like others in the borders until spring; and at other times we have indulged it with a place in the cold-frame, with others, for winter protection: and certainly this is a safe method to deal with it in localities where there is any fear about losing it; but with us, self-sown plants come up annually, somewhere or other about the borders, without any care. Two-years-old plants, however, we have always found to tire of their places, and to dwindle or die off. There is a white variety of this plant which I have never seen: probably it is not so hardy as the above and rarer.

LOBELIA CARDINALIS.—This is a native of Virginia too, and perhaps a rarer plant than the preceding. I have not seen it for many years. "Hardy as this plant is," says Mr. Curtis, in the "Botanical Magazine," "and long as it has been introduced to this country, we do not find it generally in gardens." We attribute this to its having, in a greater degree than many other plants, a partiality for a particular soil. In certain districts, where the soil is stiff and moist, it grows as freely as a weed, and in others is continually going off. Now, in most localities there is a place to be found to suit almost any plant, if due labour is given and attention to replanting in a soil prepared to receive the plants. Watchful attention, and love for the plants, will do wonders in securing the growth of any plant.—T. WEAVER.

TO CORRESPONDENTS.

*** We request that no one will write to the departmental writers of THE COTTAGE GARDENER. It gives them unjustifiable trouble and expense. All communications should be addressed "To the Editor of the Cottage Gardener, 2, Amen Corner, Paternoster Row, London."

ACHIMENES (L. S.).—The following will best suit you for a greenhouse—*Coccinea* and its varieties, *Longiflora major*, *Grandiflora Liepmannii*, *patens*, *candida*, and *splendens*. These we find stand the best. The propagation and management have been several times given, but we will repeat the main points in good time, if not shortly. You may yet try tubers any time during the winter, and keep them dry without shrivelling, and away from frost, until the end of March, and then they will want a little assistance in a hotbed, or under a hand-light, in a warm corner of the greenhouse in April.

PIGEONS (*Agricola*).—Write to Mr. Adkins, Edgbaston, near Birmingham.

GERANIUMS TURNING YELLOW (*A Constant Subscriber*).—We are much obliged for your clearly-written statement; but, judging from our

own practice, we should say that the moderate use of charcoal in the soil and drainage has quite a different effect. An ounce, or two, to a fair-sized pot we should consider moderate, which is the quantity you say you used. We should be led to conclude that alternate dryness and soakings had something to do with the yellowness of your Geraniums. We are too apt to think there is cause and effect when there is really only coincidence.

VARIOUS QUERIES (Early Riser).—Erica Banksia dropping its buds. Has it been lately shifted?—this would cause it—or has it been allowed to get dry in the interior of the ball? or does it stand in a dull place in this dull weather? In either case the remedy is obvious. The general health seems good. To prevent *Cinerarias* blooming now, cut out the flower-stalks, and replot and grow freely. If you can have successions we would not do so, but rather let them flower on, as they are cheering in the dead of winter. *Shrubland Rose Petunia*.—We think the flower sent is right from its petal, but the bright pink was changed to a purple. It seems, however, to have the bright white eye. If the colour is bright pink it is right. *Medimilla Sieboldii* not flowering.—Do not encourage it to do so now in these dark days. Keep it dryish, but not over dry, and just vegetating, during the winter, in a medium temperature about 55°, and in a light position. As the days lengthen, and light increases, give it more generous treatment, and you will probably be rewarded with flowers. *Ericas* flowering twice a year.—Many of these do so at times, especially after such a hot summer as the last, as their growth was early made and matured. It is not, however, often desirable.

ORANGES AND LEMONS (South Wales).—These, on the back wall of a small lean-to greenhouse, will do admirably. In a space eighteen feet long by eleven in height you may plant three plants, your favourite one in the centre. The more light and heat you can give them in such circumstances in summer, the more the plants will thank you. Some time back Mr. Fish gave a full detail of the subject.

VARIOUS QUESTIONS (Greenhorn).—*Verbenas* damping off.—These were struck in pans in August, have been watered lately only when dry, but still the plants next the outside of the pans keep damping off. Are you sure the plants had not been too dry before you watered them? We ask this, because we should have expected the plants to damp in the centre. Young *Verbenas* will not stand drought in the winter, and yet the atmosphere about them must be moving and dryish. If your plants are very thick in the pans, pot off the whole, or a portion, and place them at first in a close place. If not very thick, let them remain as they are, see that they do not want moisture below, scrape off a little of the surface soil, and scatter over it a layer of equal parts heath soil, powdered charcoal, and sand. If even that, in continued dull weather, should absorb much moisture, shake it off, and replace it with fresh. In another season, if you strike as early as August, you should pot off in September. *Fuchsias* straggling in their growth.—You may cut back either now or in spring. Cut down close to the surface of the soil, if you want a strong, fresh shoot, or shoots, next season; but only cut the side branches to the buds nearest the main stem, or merely shorten them considerably, if you want early bloom. See the modes of keeping mentioned lately. Your *Cape Jasmine*, straggling, and that has not flowered—take the chance of what flowers it will give you in spring, after placing it in a hothouse or hotbed; then prune it well back, and let it remain in the hotbed until it has made fresh shoots an inch or two in length; then shake it out of its pots, clear away all the old soil, or nearly so, and replot in sandy peat, with a little fibry loam, and replunge in the bed, after giving it a rather small pot. After the pot is filled with roots, shift again into similar material, only adding more loam, place it in the bed again, and harden it off by degrees. A temperature about 40° to 45° will suit in winter; and if you can place it in a hothouse the following spring, or in a sweet dung hotbed, which is better still, you will get rewarded for all your care, and find that the very attentions you bestow will insensibly change the greenness of your tree into a rich russet mature bronze.

CUTTINGS (One Thousand and One).—Your own practice seems rational enough, but whoever told you that "steam generated" in your "cold pit," was certainly in error. Damp was the cause of "fogging." Cold pits will always be too damp for late autumn cuttings; yet, to get the cuttings rooted they must be kept close so late in the season, that it follows that such cuttings should be either made earlier, or be encouraged with a gentle hotbed. In either case they should be kept close till they form roots. Surely there is no "contradiction" in all this. A good propagator could root buds of roses, and of many other plants, with a leaf and a splice of the wood to them, in a brisk hotbed in the spring; but you had better not waste your time on such nice experiments for awhile, or till you learn the more common and easier ways. We saw some hundreds of *Datura graecilis* struck from single eyes this season.

FLOWER-GARDEN PLAN (B).—We perfectly understand how your garden "looks exceedingly well, notwithstanding its simplicity." It is the best of that class we have seen this season, and you will see that we have engraved it. We are also very much obliged to you for sending it. We want as great a variety as we can get for the series; we require more particularly those which suit such places as are confined, and from 150 to 200 feet in depth, and from 30 to 40 or 50 feet in width, for our suburban villas, &c.

CUTTING-DOWN LAURELS, &c. (Ibid.).—It is by no means necessary to delay this work till July. That is the best time for the general pruning of evergreens; but cutting them back a little, or down close to the ground, may be done any time from November to May, if the weather is mild.

USE OF DECEMBER EGGS.—"In a foot-note to your article on the sale of Mr. Sturgeon's Shanghai fowls, you ask, 'Of what use for sitting purposes are eggs laid in December?' Last year, two of my Silver-spangled Hamburg pullets began to lay about the 1st of December; six of the eggs were put under a hen, and were hatched on the 1st of January, and were reared, and are now healthy fowls. The circumstances under which they were hatched were not particularly favourable; and the only precaution afterwards taken, was to keep the hen and chickens in a common garden frame."—JOHN HARLOW, Moseley, near Birmingham.

SHALLOW HOTBED (Verax).—You must remember that "A Corres-

pondent's" hotbed was probably made during summer, or before the "dark days" had arrived, and that it was enclosed with a brick wall; see page 17. Now, although a foot-deep bed is not the sort of thing to place much reliance on, we have known such a bed serve a temporary purpose—the season being favourable. You have put your questions irrespective of seasons; but we will try our hand on the averages. Such a shallow bed made of dung alone, in July, would last a month; in November, a week; of tan alone, in July, a week or two; mixed tan and leaves, in July, a week or two. To your second query, how best to convey a mild bottom-heat, we say we know of nothing equal to hot water. With plenty of manure and labour, you may, however, do much. If your pit is inside a house, a mixture of dung and leaves nearly three feet deep, with the flue, will provide a nice warmth. Doubtless your Hambro's will ripen.

VINE BORDER (A New Beginner).—We have heard and read of many vine borders, but yours for complication exceeds most of them. We have studied your case for nearly half-an-hour, and cannot confess to an appreciation of the plan. We are no users of composts. We prefer a porous turfy loam, with some coarse manural matters, and plenty of old mortar rubbish, and a border of half-a-yard deep of soil, one-half above the ground level, and you may take all your horse bones, &c. Your plan may be a good one, but we dare not commend it. If you can warm your vine roots, do. Pray favour us with your mode of growing the Strawberry.

UNFRUITFUL APRICOT (J. T. S.).—Root-prune your Apricot rather severely directly, and top-dress the border to induce surface-roots; thin the wood well.

PINE-APPLES (H. Horton).—You do not state the kinds of Pine. The probability is, that they will yet make a spring growth, and show fruit about June or July. This, however, depends much on your atmosphere. A plant disposed to show fruit generally indicates it by a peculiar sturdiness, irrespective of age. If on pulling at a leaf half-way up the stem, and shaking the plant, it appears immovable in the stem, you may soon look for a show. We should say not less than twenty inches of soil will do for them. A plant in a pot will meet with relief within a couple of years, but not so, if planted out. Pines require depth and durability of soil.

YELLOW CALCEOLARIAS (Verax).—You wish for a list of Yellow Calceolarias, distinguishing the shade. Will the one below be useful to you:—*Amplicaula*, fine lemon yellow. *Augustifolia*, pale-lemon. *Flo-ribunda*, free-flowering; pale-yellow. *Kayii*, orange-yellow. *Kentish Hero*, brown-yellow. *Shankleyana*, bronzy-yellow. *Sulphurea splendens*, dwarf; rich, clear yellow. We know a person that has several new varieties of yellow, shrubby Calceolarias, which will be ready to send out in the spring; probably some of them might suit you.

TALL LOBELIAS (A Subscriber from the commencement).—Your remarks on the tall Lobelias are perfectly just. There are great numbers that are not worthy a place in a border. You wish for a list of "really distinct and bright-coloured varieties." The following is one sent by Mr. Appleby, who says they answer to your requirements:—*Aurora*, large; light, bright purple; broad petals. *Buckii*, deep blue, white eye. *Elfrida*, violet-blue. *Fulgens insignis*, *Fulgens ramosa*, bright scarlet. *Fulgens splendida*, bright, deep scarlet. *Queen Victoria*, extra fine; deep crimson-scarlet; very brown petals. *Modesta*, lilac and white. *Purpurea*, purple, white eye. *Violacea*, violet, white eye.

APPLES AND PEARS ON WALL (J. N. Omagh).—These ought not to be nearer than thirty feet to each other. The Cherries not nearer than twenty feet. Your Peaches, Apricots, Nectarines, and Plums, you may leave as planted, at fifteen feet.

SALVIA PATENS.—The same correspondent says—"I have grown *Sabia patens* in the open ground here (north of Ireland), without the slightest protection during winter."

FRUIT-TREES FOR NORTH WALL (J. H.).—We should devote this aspect to Morella Cherries, Gooseberries, and Currants, because on it the two last-named can be easily protected and preserved to a late period. Plums, such as the *Imperatrice* and *Coe's Golden Drop*, will ripen on a north aspect, but not earlier nor better than as standards.

REMOVING VINE BARK (A Vine Grower).—You misquote Mr. Errington. He does not say "scrape off," but "peel off every portion of loose outer bark." In this, we think, he is quite right, for thereby all needless shelter for insects and fungi are removed, which might protect them from the full effects of sulphur applications.

AURICULA FRAME (W. P. B.).—The bottom of Dr. Horner's Auricula frame is closely boarded.

SHANGHAI FOWLS' EGGS (Inquisitor).—The best mode of packing these for travelling is with their small ends downwards, in a strong box, and with plenty of bran or oats between them. Pullets of this breed usually begin to lay when about six months old; if very highly fed, and hatched early in the spring, they will sometimes lay when only five months old. No eggs should be used for hatching if more than a fortnight old; the fresher they are for this purpose the better. We do not know the breed you speak of; we believe it is chiefly from Mr. Punchard's stock.

POULTRY FEEDING (Maybush).—In our experiment with the forty-two fowls, the different kinds of food were given at different times. The rice was boiled, and the greaves softened by soaking in hot water previously to being given. We shall give, some day, a drawing and description of our feeding-box.

THE COUNTRY GENTLEMAN'S COMPANION.—*Martha Thrifty* writes thus:—"I, as an injured party, beg to call your attention to the fact, that your new title to 'THE COTTAGE GARDENER' has been the source of much annoyance to the ladies. It used to be considered that a wife was the country gentleman's best companion. Now-a-days, when their long absence from home is complained of, they hold up THE COTTAGE GARDENER, and provokingly tell us they have another companion, which requires increased attention. And our sons, when pressed by us considerate mothers, to make a prudent choice, and take a companion for life, reply—'Mother, we have done so,' and exultingly hold to our view 'THE COTTAGE GARDENER.' Now, for instance, there is Master John,

who, I think, has for some time been far too fond of horses, dogs, hunting, shooting, fishing, racing, &c., and whom I, with all anxiety natural to a good mother, wish to see settled down in the world, and have accordingly looked pretty sharply out among the daughters of my friends, knowing too, that Master John had a great liking for the Misses Sensible, charming girls, one of whom I should be proud to call my daughter, and when I pressed the subject upon Master John—Oh! Mr. Editor, I thought I should hardly have got over it, he said—'Mother, I don't receive any encouragement from these ladies.' 'Because you do not pay them sufficient attention. I will renew my invitations, and then you will have an opportunity of declaring yourself.' 'Mother,' said he, with a deep sigh, 'the one I love is going to be married to Mr. Foresight, so I have determined not to be again disappointed, but to settle down and take the *Country Gentleman's Companion* for life.' Oh! Mr. Editor, what will become of our ancient house, if Master John, our oldest son, does not marry. Dear Sir, do add something to the title, that will make him wish to have a *living companion*." We consider ourselves the injured party, in having our title so misconstrued. Let our friend Martha tell Master John, that we do not call ourselves *The Country Gentleman's best Companion*, but we ask to rank among the next to her.

SHEEP (K).—Buy them at the nearest fair, and get some farmer to help you with his judgment. They will thrive on pastures which have a clayey soil, though lighter soils are better. Ewes in lamb may be purchased.

IRRIGATING WITH SEWAGE (A Learner).—As you have a tank at each end of your plot, buy a moveable pump, and with this and some open troughs you may convey the sewage to trenches cut in any part, so as to irrigate each crop or bed effectually.

UNFERMENTED SEWAGE (H. Sandford).—There can be no doubt, either in theory or practice, as to its being best used fresh. None of the ammonia is then lost. The objections, and very valid ones, to using farm-yard manure in a fresh state are, that when in such state it prevents a tidy tillage, keeps the soil too hollow, and conveys the seeds of weeds into the soil. Our correspondent would like to have some of the *Potatoes* mentioned by *Leighton* in 1850.

DAHLIAS (A Subscriber).—We cannot name dealers. Any first-rate Florist could supply you.

BEES.—*Mary* says—"Your correspondent, 'Investigator,' inquires whether it ever happens that a stock which has swarmed will swarm again with its young queen, after an interval of some weeks? In answer to this, I beg to refer him to *The Shilling Bee Book*, where Mr. Golding says, 'I once had a swarm in August from a stock which had swarmed early in June.' I have known other instances of this unusual circumstance. I shall feel much obliged if 'Investigator' will kindly inform me whether, in cutting out the queen cells, he found it necessary to take out the combs, or whether merely turning up the hive was sufficient for that purpose? My bees are in a barred box hive."

SHANGHAE FOWLS.—*K*, residing in Lancashire, says "The merits and demerits of Cochinchina fowls have of late been frequently treated of in your columns. But there is one point respecting which, I conclude the experience of the various writers in your pages and my own must differ considerably, and that is their great propensity to sitting. I hatched twelve chickens of this breed on the 30th of March last, three cocks and nine hens. Seven of the hens began to lay between the age of five and six months, and an eighth after it was six months old; the ninth has not yet commenced laying. Most of them laid daily for a month, and at the end of that time all have wanted to sit. Two of them have been allowed to do so; one on Aylesbury ducks' eggs, from which she has brought out a fine brood of six, now ten days old; and the other on her own eggs, and she recently hatched four young ones. But nothing that can be thought of will overcome the propensity to sitting in the others. For the last month two of them have been in this state. Can any of your numerous readers tell me how to manage, for if every hen of this breed after laying twenty-eight or thirty eggs must be indulged in sitting it will be a great drawback upon their value. All my friends in this neighbourhood (North Lancashire) who have these fowls make the same complaint. Respecting their eating, my servant says that they are not large eaters for their size. A friend of mine, in the adjoining town (Preston), says, that his fowls do not cost him on the average 1s. per week, and he has not any beside the purest Cochinchina." We do not find our Shanghai fowls more prone to sit than others. If they should require to sit at this time of the year, we should let them remain on their nests without eggs for three weeks, and then put them into a coop. The broody furor will then have had its natural course, and they would begin to lay again just at the time it is desirable to have eggs for sitting.

WORK ON BOTANY (P. S.).—A cheap and good elementary work is *Henry's Rudiments of Botany*.

ROSE DEVONIENSIS (T—U).—This is quite a modern variety. Any of the great rose-growers will supply it for about two or three shillings, according to the size.

BEES (J. N. William).—Feed your bees immediately with a thick syrup of sugar, honey, and water, until they weigh full twenty pounds. If their food is all gone we fear you have little chance of saving them.

ERRATA.—Page 105, col. 1, line 7 from the bottom, change "Canna India shoots," into "Indian shoots." Second column, fourth line from top, change "created" to "saved."

NAMES OF PLANTS (Mr. R.).—We cannot yet make out your plant from the seed sent, but we will notice it again. (*Killmallockensis*).—Yours is *Physalis alkekengi*. It is a hardy herbaceous plant. It is easily propagated by parting the roots. We should not like to eat the berries, though it is said to be eaten by the Germans and Swiss. It is commonly called the Winter Cherry.

CARNATIONS, defend in inclement weather. **COMPOSTS**, prepare. **CROCUSES**, take up and pot in lumps, to force in pots. **DIG** over borders, and dress all quarters generally. **EDGINGS**, trim. **FIBROUS-ROOTED** perennials and biennials, divide and plant. **FLOWERS** (choice), defend generally from inclement weather. **GRASS**, roll occasionally, if winter be mild. **GRAVEL**, roll and keep orderly. **HAWTHORN**, gather berries and bury in sand, to sow next October. **HEDGES**, plant, and clip deciduous ones. **HYACINTHS**, defend in inclement weather. **LEAVES**, collect for compost. **MULCH** round the roots and stems of shrubs newly planted. **PLANT** shrubs of all kinds. **POTTED PLANTS**, protect in deep frames, &c.; place in hothouse for forcing. **PRIVET**, gather seeds of, and make young shoots into cuttings in bad weather, lay them in damp sand or soil, and set next February. **PRUNE** all shrubs requiring regulation. **PRUNED ROSES**, scrape bark, and wash with lime and soot. **RANUNCULUSES**, defend in bad weather; plant, if mild; seedlings of them require protection. **STAKE** shrubs newly planted, and any others requiring support. **SUCKERS** may be planted as removed during the winter dressing. **TULIPS**, defend in bad weather. **TURF** may be laid in open weather. **UNCOVER** protected plants, and if not dry, place dry materials next them. **WATER** in glasses, change weekly; add a few grains of salt, or five drops of spirit of hartshorn. Buy all your **TREES** and **SHRUBS** forthwith, and put them in ground, preparatory for final planting in February. Think on the **ICE-HEAP**, and let leaves be gathered to cover it. See, also, that the ponds of water from which you get ice are freed from leaves and sticks, &c.

D. BEATON.

GREENHOUSE.

AIR, admit freely when the external temperature is above 35°, especially among hard-wooded plants not desired to have early in bloom. Those growing freely, or in bloom, should have an average temperature at night of 45°. A warm greenhouse should be seldom lower. **AZALEAS** for late blooming, keep cool. Those swelling their buds not below 45°. **BULBS**, well-rooted in pots, place in gentle heat for early blooming; put funnels of paper over the *Hyacinths*, to cause the stems of the early ones to rise freely; keep mice from the successions; few things are better for this than chopped furze. **CALCEOLARIAS**, **CINERARIAS**, **CAMELIAS**, &c., attend to with heat and moisture, according to the time you desire them to be in bloom; the two first will require frequent fumigating. **CHRYSANTHEMUMS**, water freely with manure water. **CLIMBERS**, prune generally, to give light to the plants beneath them. *Passion-flowers* may be pruned back to within a bud of the main shoots. *Tecoma jasminoides* will bloom best on longish, strongish shoots, the smaller, therefore, should be cut out; after the strength is thus moderated, by these flowering profusely, it may be spurred back, like *Passion-flowers*. Train and clean winter-flowering climbers, such as *Kennedy's Maryat*, and various *Tropaeolums*, such as *tuberosum* and *pentaphyllum*; the latter, started in summer, will bloom all the winter, but the best for this purpose in a warm greenhouse, is *Lobbianum*. **EARTH** in pots and borders keep fresh by stirring. **GERANIUMS**, encourage the forwardest, when early blooming is desirable, with plenty of air, and a medium temperature of 45°, giving them plenty of air, and tying them out. *Scarlets*, taken up from flower-beds, and kept in boxes and sheds, keep dry. Keep old *Calceolarias*, so raised, moister. **HEATHS**, keep cool, and give abundance of air in mild clear weather. **HEAT**, by fires, apply when necessary; use a little covering in severe weather in preference to making the fires strong. **IXIAS**, **GLADIOLI**, and the hardier **LILIES**, pot and set in a cold pit, to be protected from frost. **INSECTS**, keep under, by fumigating and scrubbing. **LEAVES**, dirty, wash; decayed, remove. **MIGNONETTE**, take in a few pots now and then. **OXALIS**, give winter-blooming ones, such as *lobata*, plenty of light and water. **POINSETTIA PULCHERRIMA** will make a warm greenhouse gay now for several weeks. **PRIMULA** (Chinese), introduce; water with liquid-manure when it shows the flower-bud; the double-white give a favourable and warm position; as the flower stands well when cut it is valuable for nosegays. **ROSES**, and other **SHRUBS**, introduce for forcing; commence at first with a top temperature of from 45° to 50°; if the bottom-heat is from 5° to 10° higher, all the better. **SALVIA SPLENDENS**, supply liberally with water, and give it a warm corner. *Gesnera zebrina* will still be a good accompaniment, where the average night temperature is 45°. *Salvia gesneriflora* will succeed *Splendens* in the spring. **SUCCULENTS**, keep dry, and *Cactus* especially, except the *Truncatus*, which will now be in bloom; give it a warm position, or the blooms will not open freely. The same may be said as respects position, in the case of *Oranges* opening their bloom. **WATER** seldom; be regulated by temperature, evaporation, and the wants of the plants; when the flower-buds are swelling and opened, give it oftener, and after breakfast, and with the liquid rather higher than the temperature of the house. **TEMPERATURE**, 45° during the day, 40° at night, with 5° to 10° more, at a warm end, or a conservatory, for placing tenderer and forced flowers when first introduced, allowing in each case a rise of 10° or 15° for sun heat. In severe weather, prefer covering, even during the day, to large fires; comparative darkness in a low temperature, for a short time, is preferable to light, and a parched atmosphere. Young plants just potted-off, or in their cutting-pots, suffer often at this season from two opposite causes. First, in the windows of sitting-rooms—the dry air exhausts them, and here, instead of soaking the roots, sponging and sprinkling its foliage, is the preventive. In pits and frames without fire-heat, with all the air you can give, some will damp-off. Avoid everything of a wet or fermenting material against the walls or boarding. Two or three inches thick of wheat straw tied firmly against them will help to keep the inside both warm and dry.

R. FISH.

ORCHID HOUSE.

AERIDES, *Saccolabiums*, and similar plants, keep moderately dry. **AIR**: excepting on very fine, bright, sunny mornings, when the heat of the sun and the fire combined raise the temperature too high, no air will be required this month. **BLOCKS**, plants on, syringe when the sun is likely to shine. **BASKETS** with plants in, that are growing, dip in tepid water two or three times; those not growing dip only once. **BASKETS** (new), make to be ready when wanted. **COCKROACHES**, search for diligently, and destroy; lay poison for them; the best is

CALENDAR FOR DECEMBER.

FLOWER GARDEN.

ANEMONES, defend in bad weather; plant, if mild, for the last time till February. **AUBICULAS**, defend in inclement weather. **BULBS** omitted, may be planted if the weather be mild. (See November).

candle ends crushed and mixed with arsenic—this is a sure destructive agent. HEAT, moderate, to induce rest; day, with sun, 70°; without, 65°; night, 55° to 60°. INSECTS, destroy diligently; one pair destroyed this month will prevent a numerous brood next year. MOISTURE IN THE AIR, supply to plants growing. POT growing plants: several will start this month; do this before new roots are formed. PEAT, procure; choose the most fibrous; the best is found in dry woods, where the Common Brake (*Pteris aquilina*) abounds; the roots of this fern form the best fibrous peat. STANHOPEAS, in baskets, beginning to grow, put into fresh baskets with fresh peat; four inches deep is quite sufficient. WATER at the roots, apply only to growing plants, and that round the edges of the pots. YOUNG SHOOTS, look to, and keep the centre dry, or they will rot.

T. APPLEBY.

PLANT STOVE.

AIR, give on all favourable occasions. ACHIMENES, pot a batch to flower early. AMARYLLIS, pot a portion, and plunge in a moderate tan-pit to flower early. BEGONIAS, to bloom early, repot. CLERODENDRUMS beginning to grow, repot towards the end of the month, place in heat, and water moderately. ERANTHEMUMS, winter-flowering, water freely, and occasionally with liquid-manure. FERNS, repot small plants; reduce the water to old ones; cut down decaying fronds. FRANCISCEA, pot a few, and place in heat, to flower early. GARDENIAS, pot a batch, wash every leaf, and place in dung heat, to start them to grow, and kill insects on them, especially the red spider, the great enemy of Gardenias. GESNERAS showing signs of growth, shake out of old soil, and pot in fresh compost, give little water and moderate heat till next month. GLOXINIAS, treat a few similarly. HOYA BELLA, a new and beautiful species, put in baskets, and train downwards. IXORAS, keep cool, and moderately dry, through the month. LUCULIA GRATTISSIMA, in flower, remove into a greenhouse, to prolong the bloom. LYCOPODS, divide and repot. PASSIFLORA, and other climbers, prune, and tie neatly in. PLANTS TO FORCE, such as *Azuleus*, *Persian Lilacs*, *Rhododendrons*, *Roses*, &c., place in a forcing-house, to bring them on to flower early. ROGERIAS, a genus of winter-blooming plants, should be now showing flowers. SERICOGRAPHIS GHEISBREGHTIANA, another addition to our winter-flowerers, repot, and water freely after the blooms are visible. TAN BEDS, renew, to keep up a good heat through the winter. In every department of the stove, let cleanliness prevail; clear the surface of the pots of moss and lichen; stir up the soil carefully, without injuring the roots; search diligently for insects; keep the walls and floors as dry and clean as possible; remove decaying leaves as soon as they occur; wash pots with plants in that have become green; and let neatness be the general order of the day throughout the month.

T. APPLEBY.

FLORISTS, FLOWERS.

AURICULAS and POLYANTHUSES, protect from severe frost; give air on every fine day; keep as dry as possible without flagging, remove decaying leaves, and stir the surface of the soil occasionally. CALCEOLARIAS: seedlings transplant; seed may yet be sown. CARNATIONS and PICOTEES, shelter from frost, snow, and heavy rains; give air to on fine days, even to pulling off the glass; in wet weather give air by propping up the light behind; water, if very dry; watch for slugs, and destroy them. CINERARIAS, protect from frost; repot seedlings. CHRYSANTHEMUMS, give occasional supplies of liquid-manure to, to bring out the later blossoms. DAHLIAS, examine, cut off any decaying part to the quick; protect from frost. FUCHSIAS, cut off young wood, and keep the plant dry. HOLLYHOCKS may be planted in open weather; mulch with short litter; cuttings pot off, and seedlings transplant. HYACINTHS in beds, shelter from frost, by mulching. *Hyacinths in pots*, place a few in heat, to bloom early; in glasses, wash the roots in pure water, to cleanse off the green slime; give them fresh water in the glasses. TALL LOBELIAS, take up, pot, and pack away in a shed, till they make fresh shoots in March. PINKS, look to after frost, and press the earth to the plants. RANUNCULUS BEDS, prepare. TULIP BEDS, shelter from frost, heavy rains, and snow; finish planting, b. VERBENAS in frames, give abundance of air to; if mildew prevails, dust with sulphur; protect from hard frost; water seldom, and only then when absolutely necessary; pick off decaying leaves. In this month FRESH SOILS may be procured; LEAVES collected; HEAPS of manures, loam, and peat, frequently turn over to sweeten and pulverize.

T. APPLEBY.

ORCHARD.

ALMONDS, plant. APPLES (Espalier), prune, &c.; plant, &c. APRICOTS, plant. BRINE, apply with a scrubbing-brush to stems and branches of fruit-trees, to destroy insects, eggs, and moss. COMPOST, provide. CHERRIES (Wall and Espalier), prune and train; plant. CHESNUTS, plant. CURRANTS, prune; plant. CUTTINGS of Gooseberries and Currants may be planted. ESPALIERS, prune and regulate. FIGS, protect from frost. FILBERTS, plant. FURK the surface around fruit-trees. FRUIT-ROOM, ventilate occasionally, and keep dark. GOOSEBERRIES, plant; prune. LAYERS, plant. LOAM and COMPOST, obtain. MEDLARS, plant. MULBERRIES, plant. MULCH, put around newly-planted trees. NAILS and SHREDS, draw and prepare in bad weather. NECTARINES, plant; prune and train in frosty weather. NAILING, proceed with in cold aspects. PEACHES (See *Nectarines*). PEARS, plant. PLANTING, in general, proceed with. PLUMS, plant; (Wall and Espalier), prune. PRUNING, attend to generally. QUINCES, plant. ROOT-PRUNE where necessary. RASPBERRIES, plant; prune. SERVICES, plant. SNAILS, destroy in their torpid state. STAKE and support trees newly planted. STANDARDS, remove dead and irregular branches from. STATIONS, make. SUCKERS, plant; remove from all fruits. TRAINING, proceed with. TRENCH and prepare borders, &c., for planting. THIN orchard-trees. VINES, plant, prune, and train. WEATHER (bad), provide work for. WALNUTS, plant. WALL-TREES generally, prune and regulate. WALLS, it is a very beneficial plan to paint these by means of a white-washer's brush, with a liquid mixture of 8 lbs. lime,

4 lbs. soot, and 6 lbs. sulphur. It destroys and banishes insects, as well as, by its dark colour, promoting warmth of the wall. The liquid employed, in which to mix the above, should be urine and soap-suds in equal proportions.

Any trees proposed to be regrafted in the spring, may be headed down now, but the stumps of the branches should be left sufficiently long to permit a few inches more to be cut off at the time of grafting.

R. EBRINGTON.

FORCING HOUSE.

AIR, see *Ventilation*. ASPARAGUS, promote succession crops; bottom-heat 70°; plenty of air when up. APRICOTS, see *Peach*. BOTTOM-HEAT, sustain generally about 72° to 76°. CUCUMBERS, top dress, apply liquid-manure and stop, and keep glass clean over head; air heat, 60° to 70°. CHERRIES, (see *Peach*). COVERINGS, apply assiduously, so as to be able to give air frequently. FIRES, use discreetly, to repel frost, to sustain the proper temperature, and to be able to give air rather liberally. FIGS, (see *Peach*). GLASS; wash all roofs. GRAPES, late fruit, fire freely in the day with much air; avoid spilling water in house, and use the scissors once a-week thoroughly. INSECTS, extirpate, now is the time; do not forget the soft-soap, the sulphur, the sponge, and fumigation. KIDNEY-BEANS, pot in five-inch pots, four in a pot; the *Dun's* and *Newington Wonder*; light secure by all means; keep glass clean washed. MUSHROOMS, temperature 50° to 55°; plenty of air moisture. NECTARINE and PEACH in blossom, keep at about 55° by day, at night about 40°; water very sparingly; shake branches gently, to distribute the pollen; stir earth around often. PINES, secure 60° to 70° to fruiters, with plenty of air; bottom-heat, 77° in dung-pits, keep hardy by plenty of air, and good linings; no water until the end of January. ROOTS, protect in all tubs, boxes, pots, &c. SEA-KALE, provide successions; bottom-heat 70°. STRAWBERRIES, introduce about the middle of December, earlier is not safe; begin at 50° in heat, and a bottom-heat 60°. TARRAGON, MINT, SORREL, MARJORAM, &c., introduce to bottom-heat. Let HEAT follow in a ratio to the light, at any period. VENTILATE as freely as you dare at all times. VINES to force, begin at 50°; in blossom, maximum, 70°; keep air moist, and get a warmth in border of 75°; sulphur freely; remember the dreared mildew. WATER, apply always in a tepid state.

R. EBRINGTON.

KITCHEN GARDEN.

ARTICHOKES, dress. ASPARAGUS-BEDS, dress, b.; plant to force; attend that in forcing. BEANS, plant a good main crop the first week in the month, if not done the last week in November. BEETS (Red), dig up and store, b. BORECOLES, full grown, may be taken up with good balls of earth, and planted in any nook or corner, or plot of ground of less value, in open weather. BROCOLIS, treat the same, but lay in deeper, so as to earth up the stems well; lay them in carefully, with their heads towards the north. Thus moving these vegetables gives an opportunity to prepare the quarters they occupied for other important crops; they are thus better enabled to stand the severe weather that may be expected, and, being closer together, they are much more convenient for protection. CABBAGES, plant; earth up. CARDOONS, earth up. CARROTS, store the main crops if not done, and attend to those growing in frames, &c. CAULIFLOWERS, attend to airing in all favourable weather those in frames or under hand-glasses; remove all decayed leaves, and look after slugs. CELERY, earth up, and protect when necessary. COLEWORTS, plant. COMPOSTS, prepare and turn over. CUCUMBERS, attend to those bearing; sow seed towards the end of the month for plants to plant out in the middle of January. DUNG, prepare for hot-beds. EARTHING-UP, attend to. ENDIVE, take up full grown on a dry day, and plant deep and close together at the foot of walls, or other warm dry corners convenient for protection in severe weather. HOESE-RADISH may be dealt with in the same way as directed for the Jerusalem Artichoke. HOT-BEDS, attend to. JERUSALEM ARTICHOKES, give a good top-covering of any rough mulching or garden-refuse, so as to keep out frost, and to enable them to be taken up when required; yet it is well to have a few of the roots stored for fear of snow, or other rough weather, at the very time they are wanted. KIDNEY BEANS, force, e. LEAVES, fallen, collect together. LETTUCES, attend to those advancing in frames on a gentle heat; see that no drip falls into the hearts of the plants, and give all the air the weather will permit to such as are planted in frames for winter protection only. LIQUORICE, dig up. MINT, force. MUSHROOM-BEDS, make; attend to those in production. PARSNIPS, dig up and store, b. PEAS, sow in the open ground of the best early kinds, protecting them from frost, mice, slugs, and birds. PLANTS, to produce seed, attend to, b. POTATOES may be planted in light soils in open weather, and in hot-beds towards the end of the month; examine often the in-door stores. RADISHES and SMALL SALADING, sow in frames, &c. RHUBARB, take up and pot off for forcing, or cover up with pots or tubs and fermenting materials. SEA-KALE, cover up with fermenting materials; fallen leaves are the best materials both for covering up the Sea-kale and Rhubarb. SPINACH, keep clear of weeds, and fallen and decayed leaves. TANSY, force. TARRAGON, force. TRENCH, drain, &c., vacant ground. WEEDING, attend to. Be on the alert of a frosty-looking evening, and COVER UP a little earlier. TURNIPS, any quantity, according to the demand, may be taken up and stored, or packed up tidy in a corner, to be buried in coal-ashes, so as to be come-at-able when required. We always make it a rule, at this season of the year, to store in little or much, according to the appearance of the weather, a dozen or two of *Celery*, and *Endive*, *Brocoli*, or anything else that is likely to be required.

T. WEAVER.

LONDON: Printed by HARRY WOOLDRIDGE, Winchester High-street, in the Parish of Saint Mary Kalendar; and Published by WILLIAM SOMERVILLE ORR, at the Office, No. 2, Amen Corner, in the Parish of Christ Church, City of London.—November 25th, 1852.

WEEKLY CALENDAR.

M D	W D	DECEMBER 2—8, 1852.	WEATHER NEAR LONDON IN 1851.				Sun Rises.	Sun Sets.	Moon R. & S.	Moon's Age.	Clock aft. Sun.	Day of Year.
			Barometer.	Thermo.	Wind.	Rain in In.						
2	TH	Pipistrelle Bat last seen.	30.267—30.237	41—27	N.W.	—	48 a. 7	52 a. 3	9 13	21	10 13	337
3	F	Pin-tailed Duck comes.	30.285—30.187	39—24	S.W.	—	49	51	10 30	22	9 49	338
4	S	Furze flowers.	30.245—30.234	43—35	S.W.	—	51	51	11 49	☾	9 24	339
5	SUN	2 SUNDAY IN ADVENT.	30.211—30.229	47—39	S.W.	02	52	50	morn.	24	8 59	340
6	M	Black-throated Diver comes.	30.221—30.204	49—44	S.W.	—	53	50	1 9	25	8 34	341
7	TU	Polyanthus flowers again.	30.202—30.069	51—40	S.	—	54	50	2 32	26	8 8	342
8	W	Skylarks flock.	30.214—29.919	54—25	W.	—	55	49	3 58	27	7 41	343

METEOROLOGY OF THE WEEK.—At Chiswick, from observations during the last twenty-five years, the average highest and lowest temperatures of these days are 47.1° and 36° respectively. The greatest heat, 57°, occurred on the 2nd in 1835; and the lowest cold, 14°, on the 6th in 1844. During the period 85 days were fine, and on 90 rain fell.

TANSEY-LEAVED MACHÆRANTH.

(*Machæranthera tanacetifolia*.)



THIS is a genus of Composite plants, and belonging to the Syngenesia Superflua of Linnæus. Little is known of it in our gardens. It belongs to the section of the true *Asters*, and was named by Nees Von Esenberg, from *machaira*, a sabre, and *anthera*, the male organs or anthers. The present species was discovered by Dr. Wright, in New Mexico, and from seeds sent by him to the Kew Gardens, it has been ascertained to be a handsome dwarf biennial, with

flowers as large as those of a single China Aster, and much like one; the centre of the flower is yellow, and the ray outside a purplish-blue, but in the bud, the tips of the ray resemble some red thistle just bursting. The leaves look as much like those of the Chamomile as the Tansey. It is a half-trailing, slightly shrubby plant, and will bear exposure in our open borders in summer. *Leaves* alternate, stalkless, slightly downy, cut into numerous, spreading, narrow, toothed segments; these segments become finer on the upper leaves. *Flowers* solitary, and terminating the branches with hemispherical scaly involucre. Florets in the centre, tube-like, and five-toothed. It is figured in the *Botanical Magazine*, t. 4624. B. J.

Propagation and Culture.—It has been stated by Mr. Smith, the curator of the Botanic Garden, Kew, that this novelty is difficult to propagate by cuttings, and that seeds are very sparingly produced. Therefore, the only chance we have of succeeding with it, is to begin very early in the spring, and to give a slight heat to the plant, and as soon as an inch or two of young growth is made, to make cuttings of the shoots directly. There is hardly a plant in this, the very largest order in the vegetable kingdom, that can escape such timely mode of propagation, although there are many of them that defy the art of man to root from cuttings, from the moment the first germ of a flower-bud is formed in the system.

As soon as the young plants are hardened-off; they will grow in any light, rich soil out-of-doors, but in case the seeds should not ripen, a couple of plants should be reserved in pots, and the flowers pinched-off in the bud as fast as they appear. These two plants will furnish a stock of cuttings the following season. Neither the old *Cineraria cruenta*, nor the first *China Aster*, promised so good a chance for garden varieties as this plant. If I were a young gardener, I would not rest until I drove this plant to the verge of a florist's flower. Its very aspect seems to tell as much at first sight. The habit and the leaves seem to speak of carpeting a bed, and the undecided tints of colour speak at once of a wilding got by a chance sport of nature in the wilds of Mexico. Humboldt, however, saw it cultivated there in gardens, although Dr. Wright found it in a state of nature. D. BEATON.

WE have now arrived at the most modern section of our Poultry literature; and we regret that we cannot say that it has kept pace with the improvement which is so decisive in the objects on which it descants.

If any one wishes for a delightful book about fowls, let him buy *Ornamental and Domestic Poultry*, by the Rev. E. S. Dixon. It is not only readable, but most amusing; full of information relative to the history, past and present, of all kinds of poultry, whether useful or only ornamental; sparkling with bright sketches, and even the fragments of practical detail are all touched off artistically. Take this as a specimen:—

“Shortly before the time of hatching arrives, the chickens may be heard to chirp and tap against the walls of their shell. Soon a slight fracture is perceived towards the upper

end, caused by force *from within*. The fracture is continued around the top of the egg, which then opens like a lid, and the little bird struggles into daylight. The tapping which is heard, and which opens the prison doors, is caused by the bill of the included chick: the mother has nothing to do with its liberation, beyond casting the empty shells out of the nest. At the tip of the bill of every new-hatched chick, on the upper surface, a whitish scale will be observed, about the size of a pin's head, but much harder than the bill itself. Had the beak been tipped with iron to force the shell open, it would not have been a stronger proof of creative design than is this minute speck, which acts as so necessary an instrument. In a few days after birth, when it is no longer wanted, it has disappeared; not by falling off, I believe, which would be a waste of valuable material, but by being absorbed and becoming serviceable in strengthening the bony structure, minute as the portion of earthy substance is. And yet some people direct, that as soon as the chick is hatched, this scale should be forced off with the finger nail, because it is injurious!

"All chicks do not get out so easily, but many require a little assistance. The difficulty is, to know when to give it. They often succeed in making the first breach, but appear unable to batter down their dungeon walls any further. A rash attempt to help them by breaking the shell, particularly in a downward direction towards the smaller end, is often followed by a loss of blood, which can ill be spared. It is better to wait awhile and not interfere with any of them, till it is apparent that a part of the brood have been hatched some time, say twelve hours, and that the rest cannot succeed in making their appearance. After such wise delay, it will generally be found that the whole fluid contents of the egg, yolk and all, are taken up into the body of the chick, and that weakness alone has prevented its forcing itself out. The causes of such weakness are various; sometimes insufficient warmth, from the hen having sat on too many eggs; sometimes the original feebleness of the vital spark included in the egg, but most frequently staleness of the eggs employed for incubation. The chances of rearing such chicks are small, but if they get over the first twenty-four hours they may be considered as safe. But all the old wives' nostrums to recover them are to be discarded: the merest drop of ale may be a useful stimulant, but an intoxicated chick is as liable to sprawl about and have the breath trodden out of its body as a fainting one. Peppercorns, gin, rue, and fifty other ways of doctoring, are to be banished afar, together with their subjects, namely—

'All the unaccomplished works of Nature's hand,
Abortive, monstrous, or unkindly mixed,
Embryos, and idiots, eremites, and friars,
Into a Limbo large and broad, since called
The Paradise of Fools, to few unknown.'

"The only thing to be done, is to take them from the hen till she is settled at night, keeping them in the meanwhile as snug and warm as possible. If a clever, kind, gentle-handed little girl could get a crumb of bread down their throats, it would do no harm; but all rough, violent, clumsy manipulation is as bad as the throat-tickling of the hard fingered hangman. Animal heat will be their greatest restorative. At night let them be quietly slipped under their mother; the next morning they will be either as brisk as the rest, or as flat as pancakes and dried biffins."

Next comes before us *Ornamental, Aquatic, and Domestic Fowl, and Game Birds*, by Mr. J. Nolan, of Dublin, long an amateur breeder, and now a merchant of the birds concerning which he writes. It is a volume containing much information, but ill-digested, and containing more information relative to game than to domestic fowls.

Domestic Fowl, their Natural History, Breeding, Rearing, Feeding, and General Management, by Mr. H. D. Richardson, we have before noticed as a very excellent compendium of previously published information; and in its last edition it has been revised by a practical farmer.

Lastly, we have—*Fowls: a plain and familiar Treatise on the principal Breeds*—by Mr. John Baily, the well and favourably known poulterer of Mount Street, Grosvenor Square. This little work is a third edition of his pamphlet on his great pet, "The Dorking Fowl," with the addition of some excellent and useful information relative to other varieties. We have room only for one short extract, and no room to enter into a detail of the reasons why we differ from some of his opinions.

"The real Hambro' fowl is a beautiful bird. There are two sorts, the golden and the silver; they differ in one respect only, the foundation colour of one is white, the other yellow; one description will serve for both. They have bright red double combs; clear hackles, either white or yellow; bodies spotted or pencilled all over with black; taper blue legs, and ample tails. Their carriage is gay and proud; their shape, symmetry, and their appearance is alto-

gether indicative of great cheerfulness, and carrying an air of enjoyment, which always prepossesses in their favour.

"The plumage of the cocks differs somewhat from the hens: they are very little speckled, if at all, except while chickens, when the wings and hinder parts are marked, but this seldom lasts after the first moult. In the silver variety, the cock is almost white, having sometimes a chesnut patch on the wing, and towards the tail some black spots, but these disappear as he gets older. The tail is invariably black, but the sickle feathers are tinged with a redish-white, and in the golden cock they are shaded with a rich bronze or copper. The cock of the golden is red all over, and both have well-defined white deaf ears.

"The great virtue and merit of these fowls are, they are prodigious layers, and this is not brought about by any undue feeding, but it is their nature. They are said never to set, and, as a rule, it is true of them; not one in a thousand deviates from it; but when I lived in Davies-street, I had one at liberty, she stole a nest in a lumber-room, and brought out a brood of chickens.

"They are excellent guards in the country, for when disturbed in their roosting-place, they are the noisiest of the noisy, and nothing but death or liberty will induce them to hold their peace. I think I may say with truth, they lay twice as many eggs as any others.

"In these, as in other breeds, erroneous ideas and names have crept in, some being correct descriptions of the same fowl under another name, but others being imaginative, so far as real Hambro' fowls are concerned.

"The Bolton Bays and Greys, and Chitteprats, are identical with the Hambro'. I have also seen so-called Turkish and Creoles, which were the same.

"As a general rule, it may be observed, no true-bred Hambro' fowl has top-knot, single comb, white legs, any approach to feather on their legs, white tail, or spotted hackle.

"I know no bird that gains so much by change of climate as this does; the British bred are infinitely better than the imported."

In conclusion, we have to observe, that one great deficiency more or less detracts from the value of all the publications we have passed over rapidly in review—they are not original works. They do not place before us facts stored up by the authors, or by their friends; but they retail, again and again, what their predecessors had borrowed before, and that without sufficient knowledge to select ancient truths—always valuable—but republishing them with equally ancient errors. Mr. Baily's volume claims exemption from this condemnation; but this very exemption proves the correctness of our judgment. Mr. Baily has confined himself chiefly to a statement of his personal experience and observation, and the result is a thin duodecimo of 58 pages.

We might proceed to remark further upon the great deficiency of knowledge, often mixed up with the practice of gross ignorance, relative to the diseases of fowls, which are markedly apparent in all the volumes we have enumerated; and added to these deficiencies are most imperfect arrangement, and the absence of good facilitators to reference. These defects are very extensively felt, and, combined with the wide, and more widely-growing, attention now paid to poultry, they have induced several of the best breeders of poultry to contribute the results of their experience, so as to form what we believe will prove to be the most trustworthy work on poultry that has hitherto appeared. It will be published in five or six cheap and highly-illustrated numbers, and the first of those numbers will appear in January next.

COVENT GARDEN.

WE shall now proceed, as we promised last week, to furnish our readers with a list of the fruits which we would recommend for planting, in the manner we spoke of in our last report, and to make such observations on each as may be necessary, and as our limits will admit of. In making the selections we speak of, the main object we have kept in view, is the applicability of the varieties to the generality of soils and situations, there being none of them, so far as our experience goes, which are remarkable, either for delicacy of constitution, or as capricious in their character. It will be observed, that we have avoided many of the popular varieties, such as—Ribston Pippin, and Golden Pippin, and have even introduced some, the very names of which many of our readers have never heard; yet, nevertheless, we feel confidence in what we are doing, because we are writing from experience; and although we are deviating from the beaten track, and not recommending those only, which everybody else recommends, our readers must not be the less relying. We may as well state, that the reason why we do not recommend the sorts we have mentioned, and some others which are well known, is because they are not suited for general cultivation, on account of either requiring peculiar soils, or being naturally of delicate constitution. We shall begin first, with twelve of the best dessert varieties, and then twelve of the best adapted for culinary purposes. In both cases we shall take them as to their season of maturity, beginning with those that are earliest ripe.

1. *Early Harvest*.—This is originally from America, and one of the few which succeed in this country. It is a most delicious early dessert apple, of medium size, and possessing a flavour almost equal to an imported Newtown Pippin. It ripens at the end of July, and beginning of August. The earliest native apples we have, are the Ioanneting and Margaret; but in point of size and flavour, they are not to be compared with the Early Harvest.

2. *Devonshire Quarrenden*.—Who is there, who, in early autumn, has enjoyed the rich, refreshing, vinous juice of the Quarrenden, and would not give it a place in his orchard? It is a strong, free-growing tree, an abundant bearer, and will grow almost anywhere. The fruit is ripe in the first week of August, and continues in use during the whole of that month, and the greater part of September. About the same season, but its first ripening is considerably later, we have the

3. *Summer Golden Pippin*.—A very delicious, early Apple, which ripens in the end of August and beginning of September, but does not keep much over a fortnight. This is a very first-rate variety, and prepares the way for those yellow and firm-fleshed, rich and sugary sorts, which show themselves later in the season, such as

4. *Kerry Pippin*.—This variety is now in pretty general cultivation, and, if we may judge from the quantities which are brought to market, and the prices they fetch, we may safely say it is one which has passed

the ordeal. It is certainly one of the richest-flavoured dessert apples we have. It ripens about the second or third week in September, and lasts till about the middle of October. All we need say in commendation of the Kerry Pippin is, that every one who has not got it should get it.

5. *Scarlet Crofton*.—We are coming now to what may be properly called autumn and winter apples, and we do not know of one better suited to succeed the Kerry than the Scarlet Crofton. It is a medium-sized, flattened fruit, of a peculiarly rich and sugary flavour. It ripens in October, and continues in use till December, with a very valuable property of not becoming mealy.

6. *Court of Wick*.—Although this is now generally grown in all well-assorted gardens, it has not received that attention from the orchardist which it ought. It is one of the best, as well as one of the most beautiful apples in cultivation; and while, by some, it is considered equal in flavour to the Golden Pippin, the tree is both more hardy and healthy than that variety, and will even succeed in soils where some sorts would not grow. It is in use from October to March.

7. *Downton Pippin*.—This is one of the Golden Pippin family, raised by T. A. Knight, Esq., and a most excellent dessert apple. The tree is a healthy, rather robust grower, and an abundant bearer. The fruit is ripe in November, and continues till January.

8. *Golden Reinette*.—Almost everybody knows the Golden Reinette, or ought to know it. It is an old English apple, and one of very fine quality. It is well adapted for orchard planting, as the tree is a vigorous grower and a very abundant bearer, but does not attain the largest size. The fruit is in use from November till April.

9. *Pitmaston Nonpareil*.—A richly flavoured and highly aromatic apple, which was raised by Mr. Williams of Pitmaston. It is in use from December to February.

10. *Wyken Pippin*.—A very fine, tender-fleshed, juicy, and richly flavoured dessert apple, which is in use from December to April. This should be in every collection.

11. *Boston Russet*.—This is another of the few American apples which succeed in this country to any degree of perfection; and it is certainly one of the best of our winter dessert apples. It possesses all the flavour of the Ribston Pippin, and the tree, though not large, is very hardy, and an abundant bearer. It is in use from January to April.

12. *Sturmer Pippin*.—Of all we have as yet enumerated this is, perhaps, the most valuable; not because it is superior in quality to any of the others of its season, but because it keeps longer than any other variety. It is of the richest flavour, being that of the Ribston Pippin and Nonpareil combined; and its season is from February till June.

We have thus completed the circle, and brought our readers round again to the season of the early harvest with which we started. By such judicious modes of planting, Apples of the greatest excellence may be had

throughout the year. It must be borne in mind that some of the varieties we have mentioned are not, from their habits, adapted for the purpose of which we have been treating. It will be necessary, therefore, to have them grafted standard high on strong growing varieties, which make strong straight stems.

We find our space too limited this week for the culinary varieties, but shall continue the subject in our next. We shall now proceed to note our observations in the market during the week. FRUITS still continue plentiful. That fine cooking apple the *Dumelow's Seedling*, or as it is sometimes called *Wellington*, begins to come in and meet with a ready sale at 4s. 6d. to 5s. per bushel. *Winter Pearmain*s have also made their appearance. This is one of the oldest apples on record, and can be traced back to the reign of King John, at which period it was in large cultivation in Norfolk. What would Mr. Knight say to this in support of his theory? We shall speak of this variety next week when noticing the culinary varieties. We have not observed anything new in the way of apples during the week, besides what we noticed in our last. In PEARS there are some very fine *Glout Morceau* and *Passe Colmar*, together with a few *Nelis d'Hiver*, but we shall have occasion to speak of these when giving our list of select varieties for orchard planting. The prices which these are making are from 3s. to 4s. per dozen.

In VEGETABLES there is no scarcity, notwithstanding the great damage which was done by the recent high tides in the garden-grounds about Fulham. One of the largest cultivators informed us a cheque for £500 would not cover his loss. His men were actually navigating the grounds in boats.

PLANTS AND FLOWERS are much of the same description as have been in the market for some two or three weeks past, consequently we need not enumerate them. But, for the information and gratification of our lady readers, we must record the construction of a very beautiful *Bouquet*. The centre was formed of a very fine Double White Camellia, round which were set, in a concentric circle, a Double White Camellia and a cluster of Scarlet Geraniums alternately, five of each; between each White Camellia there were three flowers in a cluster of a very beautiful azure blue Cineraria, of a peculiarly rich and lustrous hue; the whole was fringed round with fronds of some small-growing fern, and encircling these a margin of lace paper. It was the most beautiful bouquet in the market.—H.

GOSSIP.

EAST, West, North, and South, we are right glad to find that *Poultry Exhibitions* are being established. We have before us prospectuses for one in Wales, at *Hay*, on the 16th of December; for one at *Salisbury*, on the 13th of the same month; for one at *Hythe*, in Kent, but the day not fixed; and for one at *Dublin*, on the 8th and 9th. We repeat, we are right glad of this, for it is for the encouragement of a species of stock that may, and ought to be found around every cottage, even

in greater perfection, than around the farm-house and the mansion. But, whilst we rejoice over this extension of Poultry Shows, we would strongly protest against the abuse of them. We have no idea of their being held for mere gain to the parties establishing them, and it is only a still worse feature, if that gain is intended to be obtained by the sale of eatables and drinkables by some neighbouring innkeeper. We yield to no one in the desire to have a metropolitan show, but we do not recognise, as worthy of such a character, either that at Hitchin, or the proposed one at Kennington Oval. We are led to suspect that the latter has the gain we deprecate for its object, and at all events, the originators of both the shows in question, took not into consideration, before they issued their Prospectuses, either the welfare of the poultry, or the interests of the exhibitors. Who that has a just regard for his fowls, will send them from home for a week, five days of which they are to be penned up at the Exhibition? We know of more than one of the best breeders, who would not, on this account, send them to Hitchin, and we know of a still greater number who will withhold their specimens from the Kennington Oval, on the same account. They have acted wisely for their own interests, and humanely for their fowls, by so doing, and we hope that no future exhibition of them will be kept open for more than two days.

We are informed that *Lord Calthorpe's Small Garden Tenants*, near Birmingham, about 150 in number, have formed themselves into a Horticultural Society, and intend to have a show of flowers and vegetables, and we hope fruit is to be included, twice a-year. We shall be glad to aid this and all such societies.

A subscription for *Professor Von Eisenbeck*, whose penury and distress we mentioned in our last number, has been opened, and a remittance already forwarded to him to rescue him from immediate want. Any donation, however small, may be sent to Mr. Edward Newman, Devonshire Street, Bishopsgate.

As long since as 1811 a plant was introduced from North America, that had been still earlier known to the Canadian boatmen as the *Pomme de Prairie* (the Apple of the Prairies, or Plains). They eat its roots, either boiled or raw, these roots being nutritious and insipid, but of a solid texture, and not among the most easily digested foods. To botanists the plant is known as *Psoralea esculenta*. Another recent attempt has been made to introduce it into cultivation as a substitute for the Potato, but we fear that it will not succeed in any available mode. We speak of it as another attempt, because a very few years since its culture was tried in England; and the present attempt is being made in France by M. L. Picquot, No. 11, Rue Guy-Labrosse, Paris, who has called the plant *Picquotiane*.

The following is a list of the *Horticultural and Poultry Shows* of which we are at present aware. We shall be obliged by any of our readers sending us

additions to the list, and giving the address of the Secretaries.

HORTICULTURAL SHOWS.

CALEDONIAN (Inverleith Row), Edinburgh, Dec. 2.
LONDON FLORICULTURAL (Exeter Hall, Strand), Dec. 14+.
SOUTH LONDON (ROYAL), Dec. 9+, 16.

POULTRY SHOWS.

BIRMINGHAM AND MIDLAND COUNTIES, 14th, 15th, 16th, and 17th December.
BRISTOL AGRICULTURAL, December 7th, 8th, and 9th. (Sec. James Marmont.)
CORNWALL (PENZANCE), January 10th, and 11th. (Secs. Rev. W. W. Wingfield, Gulval Vicarage, and E. H. Rodd, Esq.)
HONITON, January 12th. (Sec. H. K. Venn.)
SALISBURY AND WESTERN COUNTIES, December 13. (Sec. T. Pain, Esq.)
WINCHESTER, December 1st. (Secs. G. W. Johnson and J. Colson.)

† For seedlings only.

PINE-CULTURE: THE HAMILTONIAN SYSTEM.

(Continued from page 122.)

WE will now look over Mr. Hamilton's notes, his book, &c., to see if anything has been omitted, or if anything material can be added. Our remarks must, of necessity, assume a desultory character; but they will not be without their use. We will discuss the following heads, alphabetically arranged to facilitate reference: anything which may occur afterwards may form an appendix:—*Atmospheric moisture, Bottom-heat, Composts, Disrooting, Errors, Foliage, Kinds, Longevity, Main principles, Moisture, Old stools, Planting out, Pipes, Root-culture, Recipes, Ripening, Soil, Structures, Suckers, Syringing, Temperature, Ventilation, Watering.* It will, as we think, be far better thus to examine principles, than to give a mere detail of practice, however sound. The essentials once fixed in the mind, a sound practice must necessarily follow.

ATMOSPHERIC MOISTURE.—Here we have one of the most important of all the headings. No plan of Pine-culture can succeed which does not provide a liberal amount. Exceptions there may be at such periods as that of the ripening, but they can be only in degree, and through the successive character of the fruit, not readily practicable. But it is worthy of remark, that some respectable pine-growers think that Mr. Hamilton, in his ardour to produce a vast amount of fruit from a narrow compass of glass, has ridden his hobby a little too hard as to air-moisture in his winter management. We do hope for pardon from Mr. H. whilst we, as a duty, observe, that as a close, warm, and damp atmosphere doubtless favours the enlargement of the Pine, it in like measure favours the enlargement of the crown; and a large crown is neither admired by the table-decker, nor by the pine-purchaser. We would here beg to interpose a hint, and that is, that with no class of plants with which we are acquainted, can the relation of light, heat, and moisture, be a matter of indifference. Winter in Britain is dull, if not dark; therefore, the high-forcing principle is not Nature's way of Pine-culture. Doubtless, we may take some liberties; but caution is requisite; and common sense, though not very romantic, is sometimes exceedingly useful as a guide in difficulties. We say, therefore, so manage your system as that you can at any time supply any amount of atmospheric moisture, and as speedily remove it if needs be; but we must pass briefly to other main points.

BOTTOM-HEAT.—What fearful reminiscences may this very heading bring to the memory of every King of

Spades whose hair has become bleached in the service! How many root burnings, as well as heart burnings, may be called to remembrance? Mr. H. says (p. 55), "Newly potted plants will be benefited by a heat of about 90° for two or three weeks; after which time it may fall to 85° max. and 80° min.; but in the winter 75° will be sufficient for successions. The bottom-heat required for those plants which are to produce several fruits from the same plants ought to be as equable as possible, at a medium of about 80°, and not to fluctuate more than 3° above or below. However, I have known a plant to swell well in the summer in a bottom-heat of 70°; but in winter, when the superincumbent air is kept cooler, the plants that are swelling their fruits will make but little progress except the bottom-heat be about 80°." We may here caution young beginners against the erroneous idea of going a-head by means of extreme bottom-heats: we advise them not to exceed 85° on any account, until they quite understand the habits of the Pine. We saw some of the finest grown Pines in England, this summer, at Alnwick Castle gardens, the seat of his Grace of Northumberland; gardens kept in capital order by Mr. Pillars, the head gardener. The bottom-heat to these Pines could not have been above 75°, and the pots only half plunged, Mr. P. preferring to depend on a pot full of robust roots, to any extra attempts at stimulating the vital action of the plants.

COMPOSTS.—At p. 7, Mr. H. says, "With regard to rich composts, I mean not to dispute their efficiency; I can assure the public, however, that the Pine will flourish well without them if the system of root and atmospheric moisture here recommended be adhered to: water and air, there can be little doubt, constitute the principal food of the Pine-apple." These are strong views, and no doubt, in the main, correct; but it is well known that some of our best pine-growers use liquid-manure, and this we think by far the best form of manuring; for the admixture of manurial matters in the soil has a tendency to hasten the decomposition of the organic matter; and we do think that on the long preservation of this depends, in a great degree, that longevity in the roots which Mr. H. takes as the basis of his system. See heading "*Longevity.*" Mr. H. has, since writing his very useful little book, stated to me by letter, that he considers a good loam, rich in vegetable fibre, complete in itself for the culture of the Pine; and we recommend the opinion to our readers.

DISROOTING.—This, about which so much fuss was made in our laddish days, is now entirely repudiated by all good gardeners, and is only justifiable when plants have received abuses, injuring or destroying their roots; or in case the soil in their pots has become what is technically termed "soured." For further notice, see "*Longevity.*"

ERRORS.—We merely take this in its course to direct attention to one or two which have somehow crept into our remarks; they will be corrected in the conclusion.

FOLIAGE.—Those who watch the evidence in this Pine case will remember Mr. H.'s dry way of defending the poor unoffending foliage. "Be as careful," he says, "of cutting the foliage as you would of cutting your corns." This language, although not remarkable for dignity, is highly emphatic. At p. 63 of his unmistakable little book he says, "No destroying nor shortening healthy leaves," &c. Would not the late Mr. Knight, of Downton, have rejoiced to find that his deep diving into Nature's secrets had not been in vain; that the very class of men who were best able to appreciate high principles (and, perhaps, least fitted to seize them at one period through the giant-like tyranny of that hard slave-driver, prescription) had entered into his labours. Let then, we say, no man cut away a leaf of a Pine until he can show a sound reason (not fancy) for so doing. Mr. H.

very valiantly contends for the astounding longevity of the Pine roots: why did he not say that the foliage was barely second to them in that capacity? Those who desire to look further into this matter may just refer to pages 37, 64, and "Address," p. 6, of Mr. H.'s edition of 1845.

KINDS.—There are, perhaps, some sixty varieties or more in this country, but the principal kinds grown are the Providence, Queen, Enville, Jamaica, and Cayenne. Mr. Hamilton's planting-out system has been principally confined to the Jamaicas, Queens, and Providences; though, we think, he has not cultivated the last to the extent of the two former. He says, "All the Queens, except the old variety, are well adapted to my system. The old Queen is apt to breed too many suckers." In another place he says, "I like the Queens best for quantity of fruit." What the Cayennes may prove under this system is not well decided; but it must be kept in mind that the Jamaica is the most valuable as winter fruit; the Queens then become insipid.

LONGEVITY.—It was formerly considered that the roots of the Pine possessed no vitality worth consideration beyond a year or two; but the fact was, gardeners generally contrived to shorten the days of the roots by bad culture. Mr. H. says (p. 6, 2nd edit.), "It has, however, been established, by the results of many years practice at Thornfield, that one Pine plant is capable of producing one or more fruit annually for any period of time." Again, p. 49, "I had remarked that all the largest fruit, but more particularly the Enville and Queens, were produced from those plants which had been the longest potted previous to fruiting." Mr. G. Jennings, of Knowsley, the seat of Earl Derby, and Mr. Fleming, of Trentham, have, he says, adopted his ideas; Mr. J. has produced splendid results, and Mr. F., it seems, has, in a public print, pronounced Hamilton's system to be the best; this mode of culture, as before observed, being based principally on the longevity of the roots. There can be no question, it appears, that those minute fibres, scarcely visible, and which ramify with age in all directions, penetrating drainage materials, and every lump of turf or soil, possess vast absorbing powers, and that of a *continuous* character, if totally undisturbed. These were despised in former times; our old cultivators could only recognise those lusty white roots which the Pine makes up the stem, and to obtain which, disrooting and other tricks were had recourse to. Those who understand the culture of Orchids will very well understand the position of this question. We do not expect to find our friend Appleby disrooting and leaf-stripping his huge specimen Cattleyas every year, unless it be to make a five pound plant into a ten-pounder, by cutting ten slices at a pound each.

MAIN PRINCIPLES.—These, in the abstract, may be thus summed up:—1st. A secured air-heat adapted to the season: summer, 75° to 85°; winter, 60° to 70°; other periods about intermediate, principally ruled by the amount of light. 2nd. A certain and little fluctuating bottom-heat, bearing a close relation to the air-heat, in summer about 84°, winter about 75°; other periods principally graduated according to the demand on the foliage through light and heat. 3rd. Atmospheric moisture at all times in proportion to the amount of heat. 4th. A liberal ventilation without sudden checks, on principle for the purification of the air, and as an expedient to reduce extreme heats. Lastly, undisturbed root action, in a proper and long-enduring medium. Now this is simply an epitome of all the rest, and to knowing pine-growers may seem superfluous; but as these papers profess to set the matter on a plain footing to a rising generation of pine-men, we feel that the matter cannot be set in too strong a light.

MOISTURE.—Here we have air moisture, and root moisture; two very different affairs. The former can

hardly be supplied in a too liberal way by any of the ordinary means, provided heat and a free ventilation be concomitants. As to root moisture, little is needed by the Hamiltonian mode. Mr. H. writes thus as to an inquiry about watering—"I have watered at the root twice this summer." It must be observed here that the plants are out of pots; their immoveable fibres seizing on and investing all kinds of material in the bed, soil, turfy matters, and even, no doubt, the very stones, debris, &c., &c., attached to which they have a proper feeding ground, an exemption from dangerous extremes, and, doubtless, collect food continually from the gaseous matters by which they are surrounded; the latter brought into play by heat and moisture.

OLD STOOLS.—Mr. H. is all for planting clean stools, if to be had, in preference to young plants, unless the latter are exceedingly strong. He, however, shows that, although Mr. Knight, of Downton, used old stools, that they were in error in totally disrooting or shaking the soil from the roots; "by which practice," he says, "I have discovered the plants will frequently make a long growth before they fruit." Our readers will here see the importance of planting such stools out without disturbance. If, he adds, they cannot be had with roots and balls, there need be no hesitation in planting them without at once into the compost, where, if handled according to the directions in his book, he will guarantee them to produce first-rate fruit the first year. He adds, "They may be planted at any time."

PLANTING OUT.—This heading is almost a repetition of the former. We will, nevertheless, take this opportunity to suggest attention to the modes described in an earlier paper, viz., that twenty inches of soil is enough, and that the pipes be covered with broken bricks three inches, also three inches between; the pipes will, consequently, be fairly imbedded in bricks or rubble of some kind. And here, one remark. Any one about to commence might fancy the soil would get too dry without some provision for water; but such is not the case it appears: Mr. H. solidly affirms this. Indeed, the following extract from a recent letter will show how this stands: "You seem surprised about the 'Chamber' affair. I have dispensed with them everywhere, or nearly so. I have proved the beneficial effects of covering the pipes with rubble (instead of chambering) for twenty years, and never found any inconvenience from the soil getting caked or dry. I should be cautious of laying anything that is a non-conductor between the rubble and the soil. The rubble at the top may be covered with rough gravel, the fine sifted out."

In another paper we shall probably finish the Hamiltonian system. R. ERRINGTON.

RULBS.

(Continued from page 142.)

Alströmeria Hookeriana, alias *rosea*.—This is a beautiful dwarf species, and one of the hardiest of them, keeps its leaves the whole winter in the open border, unless the winter is very hard; and if the tops get killed it is the first of them which is above ground in the spring. It will grow in the very richest kitchen-garden soil; but the front of a vinery, where the border is well drained, is the place it likes best. It is also a good pot-plant, as the leaves and flower-stems are more rigid than any of the rest—besides being dwarf, like *pulchra*. The colour is difficult to describe: *rosea* was a bad name for it, as one-half of the flower is not rose colour; the points of the petals are greenish, then rosy, the bottom of the upper or back petals are light and full of streaks and speckles, with a shade of yellow between the white and rosy parts. It will not cross with *peregrina*, *psittacina*, or *aurea*.

A. peregrina (the Foreigner).—This is the oldest of

the genus under cultivation. It was gathered along with a few more of them by a Frenchman named *Feuillet*, who first introduced them. *Linnæus* named them for the Frenchman, and founded the genus on *peregrina*, but, by a misprint, it is called "*pelegrina*," in *Feuillet's* book; and in the *Cottage Gardeners' Dictionary*; also in every list of them, but one, that has appeared in the old or new world from that day to this. Dr. Herbert corrected the error, however, in 1837. *Peregrina* means "a foreign lady," and it is evident that *Linnæus*, who was fond of joking, gave a feminine termination to Baron *Alströmer's* name, purposely to suit *peregrina*. It is one of the best pot-plants among them, and is hardy enough to live in a border or cold pit, if the border is slightly covered during frost. There is a garden variety of it with white flowers, which does better in a pot, and *Cumming* found a greenish-white variety of it near *Valparaiso*; still it is not easy to get it to cross with others, and the white one does not always come true from seeds.

A. psittacina (Parrot-like).—This is the next tallest and hardiest after *aurea*, and will grow and flower in the open border in any good garden soil. The flowers are dull red, with green tips and black spots. This came out in 1829.

A. pulchella (Pretty).—Orange and red, approaching to scarlet. For many years this was considered a distinct species, and, as such, it was figured in all the Magazines; but now it must fall into *Van Houtte's* Ghent varieties along with another called *Simsii* or *Simsiana*. They are all from a common type—*hæmantha*, and any one may run them into endless varieties. Since I wrote about *hæmantha* (page 142), I have learned that *M. Van Houtte* denies a hybrid origin to his seedlings, but that he had them from wild seeds—which only proves that the seeds were gathered in South Chili, where *Pöppig* states that he found *hæmantha* in meadows near *Antuco*, running into all shades of red, orange, lemon and white. Another, called *pilosa* in the "*Botanical Register*," is one of them. All these varieties make a gorgeous bed planted together, and are as easily managed as so many common tulips or hyacinths, only that the roots ought to be taken up every other year to prevent their going too deep in the bed.

A. pulchra (Fair).—This is the last in our enumeration of them; it was first figured in the *Botanical Magazine*. It is called *tricolor*, in *Hooker's* Exotic Flora, and *Flos Martini*, in the *Botanical Register*. *Cumming* found it near *Valparaiso*, and it appears to have a great range in Chili, according to the other travellers. When I was collecting the species, many years ago, I found two or three seedlings of this at *Mr. Loddige's* Nursery, at *Hackney*; they were a dirty white, with green tips, and not worth much, but proving how much they are given to sport. *Tricolor* is a better name than the true one, but it has four distinct colours, if not five—a white or light ground, streaked with purple, red and green tips, with a dash of yellow across the petals. It is quite as hardy as the rest of them, and is well adapted for pot-culture. I once had a beautiful bed of them, a circle, planted thus—a large mass of *aurea* in the centre, then a row of *psittacina*, round that *hæmantha*, and some of *pulchra*, and *peregrina*, in one row, for want of a good stock of them, with a border of *Hookeriana*; this bed I afterwards turned into a basket-form, by planting a row of *Bomarea acutifolia*, and *hirtella*, or *ovata*, as some call it, quite round the sides; the bed was three feet deep, and nearly one-half of quite rotten leaf-mould, with a soft yellow loam. The two *Bomareas* grew ten to twelve feet in this, and were trained round and round, and at a height of eighteen inches, on sticks with a handle of hazel rod

across, on which *acutifolia* was trained from both ends. This bed was much admired, but now, by using the best of the Ghent seedlings, along with *aurea* and *psittacina* in the middle, a splendid bed, of any shape, might be made much easier, and I can vouch for it, that if it was hedged with these twining *Bomareas*, planted also eighteen or thirty inches, so as to get a thick mass of them, they would much improve the bed, and be in character too, besides the novelty of the thing; for I am not aware of any one else having ever used them so. I may remark, that almost all the *Alströmerias* are natives of Chili, and that out of forty *Bomareas* described, none were found in the whole of Chili, but two species. The rest are natives of Peru, and northwards into Guatemala and Mexico.

Amaryllis.—Since this genus was printed for the *Cottage Gardeners' Dictionary*, strange relations respecting it have appeared, which overthrow both Dr. Herbert's arrangements, and that by Dr. Lindley, in the *Vegetable Kingdom*. The greatest amount of practical knowledge on one side, and consummate philosophy on both sides, were not sufficient to bear the natural test of a true arrangement. In the *Amaryllidaceæ*, the greatest point of difference by which *Amaryllis*, and other allied genera are kept asunder, is a solid flower-stalk, or a hollow one. So many genera have the flower-stalk hollow, or pipy, and so many the reverse. According to Dr. Herbert's ideas, a bulb with a solid flower-stalk or scape, could no more be crossed with one having the scape hollow, than with "an oak-tree."

In the *Vegetable Kingdom*, the true *Amaryllids* are also divided into two sections, the point of difference being the cup or coronet, peculiar to many of them, as the cup inside the flower of a *Narcissus*. All *Amaryllids* having this cup in the flower are in one division, and those of them wanting the cup in the other. Two very simple and convenient arrangements, but they are not natural, neither are the genera in them placed according to their natural affinity. In both, *Amaryllis* is placed far from *Vallota*, and in both, *Vallota* is kept much asunder from *Brunsvigia*, yet the three ought to stand side-by-side, and be followed by *Cyrtanthus*. Dr. Herbert could not cross one species of *Brunsvigia* (*multiflora*) with *Amaryllis*, therefore, he thought *Brunsvigia* might "yet be upheld." But in New South Wales, where all the *Brunsvigias* and *Amaryllises* cross freely, the cross seedlings from *Brunsvigia multiflora* are the most showy of all, as we might expect. The gentleman who effected this cross with whom the plants first flowered in 1847, tells us (*Gardeners' Chronicle*, 1850, 470), that as many as from twenty to forty flowers were on a single scape, and that the "colour is generally like that of *Passiflora kermesina*." And at home I have put the union of *Vallota*, *Cyrtanthus*, and *Brunsvigia Josephine*, beyond a doubt. If Dr. Herbert was alive, he would be the first to acknowledge the necessity for re-arranging of the genera afresh, and this explanation was necessary at the outset, in order to remove doubts that might naturally be entertained against such and such crosses as I shall suggest here and there in these papers on bulbs. I have no wish to change a single name; it is more convenient to hold on as we are, as we do with *Azalea*, *Rhodora*, and *Rhododendron*. All that I claim is, a fair hearing, because I have now no means of pushing such experiments myself.

Amaryllis Belladonna.—This is the best known of all the family; and whatever we may think of the soil in which it is found growing at the Cape, there is no doubt but it likes a good rich soil and an open air treatment in this country. I never saw it growing in a pot half so finely and so vigorously as it does in the open air. Miller's compost for it is as good as any that has been tried since; at two feet deep, after draining the border,

he mixed a quantity of rotten dung; after that he put a foot of rich garden loam, planted his bulbs, and used a lighter soil on the top, the bulbs standing six inches deep. We have seen lately how beautifully they get it to flower at Claremont under similar treatment, and a change every sixth year. I have also seen it flowering well with the bulbs nearly out of the ground, in a very rich border. It increases fast from off-set bulbs, but does not seed freely, or but very seldom in this country. In Australia it seeds freely enough, and the cross seedlings from it there would be a great acquisition in this country, particularly the crosses from the pollen of *Brunsvigia multiflora*; and there is no reason why it should not sport there as *Hippeastrum* does here. *Belladonnas*, and all other bulbs which grow in winter and rest in summer should not be planted in *mixed* borders, nor where the roots of large trees or bushes can reach; the latter will suck away the goodness from the soil; and growing plants require water in summer; and these *Amaryllises* are better in the dry while they are at rest. There are two varieties, one of them paler; and the third species mentioned in the *Dictionary*, *Blanda*, is not in any public collection in this country, as far as I can learn. When I come to the other sections of the genus, I shall speak of the best mode of treating a whole collection of them; but, as they are now pushing out of the ground, I may remark generally, that they require air constantly, and large doses of water from the time the leaf is two inches long; and if they are in pots it is better to water them from below by a saucer full of water, now and then, but not constantly; say as much as the soil can take up in a couple of days; then take away the saucer for ten days or a fortnight.

There is a scarce little bulb, called *Cyrtanthus uniflorus*, *Gastrenama clavatum*, and other names. It is a true *Amaryllis*, and so are all the *Cyrtanthus Brunsvigias*; and there is little doubt but *Strumaria* and *Hessea* are also true *Amaryllises*—at any rate they require the above treatment at this season, as well as all other half-hardy bulbs that grow in winter.

ANDROCYMBIUM.—There are three species of this little-known genus in our *Dictionary*, but they are not worth while for their beauty, only as botanical sections, or curiosities; that they require sometimes to illustrate lectures and so forth. Their flowers are small, and dull, greenish white.

ANISANTHUS (see *Antholyza*) from which Sweet divided them upon grounds not now recognised by botanists.

ANTHERICUM is on any list, but there are no bulbs in it, and therefore I shall pass it, although botanists make it a section of the lilies; at best they are only *Asphodels*.

D. BEATON.

(To be continued.)

VIOLETS.

IN this age of glitter, it is something to find that *worth*, however retiring, is not always passed by and forgotten. The *brilliant* rivets the attention, and affords full play to a buoyant imagination. The *good* is more securely enshrined in the recesses of our warmest affections. Insensible though the world be to *merit*, I believe it is hardly so black a transgressor as many aspirants for distinction would have us believe. But to win the approbation of the world the merit must be *real*—no plated, gilded thing will long pass muster. And, again, the *merit* must be free from alloy, not associated with the impure or the revolting. Then we will freely own that the greatest worth is not always conjoined with the greatest show, and that there are many bright deeds, and many bright things in this world of ours, which are but little noticed by a dreamy philosophy.

Would any reader enjoy a quiet insight into men

and things, let him, in an hour's leisure, glance over the advertising columns of a daily newspaper, or even of those connected with our own humble serial. What a satire at times upon vanity and upwardism! What an unfolding, in general, of prevailing wants, tastes, and aspirations; and, above all, what joyous hopes infused, frequently, for the future. Advertisements will appear just as long as they suit a purpose. Between the line of the beautiful in nature, and the appreciation of the lovely in morals, there is a close connection. Every advertisement, therefore, respecting the gorgeous in flowers, speaks of a refining influence healthily spreading. Every statement announcing where *superb violets* are to be procured, declares not only that the same bettering influence is being felt by the humblest in society, but also, that if not the *already* and the *now*, the period is *nearing*, when true worth, however retiring, whether among plants or men, shall receive its due meed of approbation. Who can forget emotions of the past, associated with a single bloom of the lowly *violet*? Who has traversed the brakes and hedge-banks of society without discovering there, again and again, many of the noblest virtues that adorn humanity?

Several inquiries having lately been made on the general management of these much-prized plants, our Captain Editor has wished me to have "my say" on the subject of *violets*, although I have, in one of our earlier volumes, already noted the main points of management. Referring back might not, however, suit some subscribers, and, as at present I cannot lay hands upon the paper myself, readers will have the advantage of any changes of practice that have been suggested since then. The kinds or varieties will be mentioned in rotation, according to the estimate formed of them, and their early autumn, winter, and spring blooming.

1. NEAPOLITAN VIOLET.—This I still consider to be worthy of a first place, both on account of the *size* and *sweetness* of its lilac flowers. There is one disadvantage connected with it, namely, that it seldom does any good out-of-doors, unless in a very dry and sheltered situation, and even there they will be late. A conservatory, or a glass-covered pit or frame is the place for it in winter. For this purpose young plants are best.

Propagation. This is effected by runners and divisions. First. *By Runners.*—These, if wanted, may be allowed to grow in spring, *but at no other time.* They may be cut off when three inches in length, and inserted in sandy soil, under handlights, on a slight hotbed in March and April. When well rooted they should be planted out in a nice mellow border, about eight inches apart. Second. *By Division.*—This mode involves least trouble, and I think it is the better of the two. Take the plants that have done flowering in April or May, and tear them to pieces with the hand; one plant may thus be made into a good number, each supplied with a nice crown of leaves and roots. Plant these out as mentioned above for the cuttings, giving them from six to eight inches from plant to plant.

Summer treatment.—Almost all the success depends upon this. The *soil* should be mellow, open, and well drained, enriched with a fair proportion of rotten dung, or leaf mould, and if the soil is very adhesive, a good proportion of road or drift sand. The soil should also be frequently stirred after planting. *Waterings* must be duly attended to, and, if a vestige of red spider appear, the plants must be well drenched with soot and sulphur. *Shadings* will be required at first, but as soon as the plants are taking free hold of the soil they must gradually be exposed to every ray of sunshine. Every *weed* will tell against success, because it will prove that neither cleanliness nor stirring the soil has been attended to. Every runner *must* be removed as soon as it appears. Unless produced *very early* in the season, not one

of them will produce anything but leaves during the following winter and spring. This is a first and most essential point of management. Culture must be directed to obtaining strong well-matured heads or crowns; every runner, after a certain size, will be alike a *shader* and a *robber*. When first planted out, and root action is desirable, they need not be nipped too closely at first, but, after free growth is proceeding, every weed should be looked upon as an intruder.

Winter management.—In October they should be taken up and potted, or placed in a bed to be covered by glass. But why not cover them where they are, and thus save labour—if the bed was well prepared at first I do not see why the plants should be moved? The first essential for such saving mode would be the securing of the glass not further than six or eight inches from the plants. But even then, when I tried this mode, I found it was no saving in the end. For instance, the ground was apt to be too wet, and thus the flowers were likely to damp in winter. Both slugs and worms were prone to have their colonies, and then woe betide the beauty of the flowers; and besides, leaves were likely to be more abundant than blooms. When transplanted, on the other hand, though raised carefully in balls, a check was given to the growing principle, just enough and no more than to give a hint to the flower-buds to show themselves; and by the time the buds swelled, the roots were spreading in the *fresh* soil, and thus catering for strength of flower-stalk and size of blossom. In planting in the flowering beds, one of two modes may be adopted according to circumstances. First, where the situation is damp and cold: here it is advisable to raise the bottom of the bed one foot above the surface-soil, either by faggots, old wood, clinkers, stones, or even common soil—above this, if the bloom is wanted early, it will be advisable to have a slight hotbed, one foot in thickness, at least, and over that three inches of rotten dung, or leaf mould, made firm, and over all, eight or nine inches of sandy loam, rather rich and rather dry. When the situation is warm and dry, the soil being sandy, resting on gravel, chalk, or porous rock, then any position in the garden facing the south, or south-west, will answer admirably. A little leaf mould may be added, the soil be well stirred and aerated before planting, and if at all wet or exhausted, a few barrowsful of good, fresh soil may be added. In planting, beginners should attend to one little matter: take out a trench across the bed, set the plants so near as to leave a couple of inches round them, pack them firmly with the soil, and then water thoroughly, and when that has drained away, cover the surface with the dry, unwatered soil. It is scarcely possible to have the surface too dry in winter if there is moisture enough below. In addition to this, I often cover the surface between the plants, when fairly growing, with a slight layer of dry road-drift and charcoal, which, besides helping to promote a dry atmosphere, slugs can wriggle along, but very slowly, amongst such material when dry. In addition, I may add, that *air* may be given freely when the external temperature is about 40°, especially when the sun has raised it higher; and *frost* must be excluded by covering the glass, and protecting the sides of the box or pit. *Pots* for the window, or greenhouse, may be managed in a similar manner; one large, or three small plants for a six-inch pot. This sort involves a little trouble; but that given, and these *little* matters looked to, there will be no disappointment. All the rest are easier managed, and will require less to be said about them.

2. PERPETUAL OR TREE VIOLET.—This is a useful variety. It well deserves the name *Perpetual*, as I have seen it bloom from September to June. The title *Tree*, may not be a misnomer, as this violet may suit that mode better than others; and I rather think it does: though each and

every one of them may be grown in that *moppish* manner where desirable. A number of complaints reached me last winter and spring that it would not bloom early. In every case that came under my inspection the parties had received a counterfeit—namely, the common double blue, a fine thing in its way, producing, when well grown, finer flowers than the *Perpetual*, or *Tree*, but then it will rarely or never bloom in winter—it may also be known by its flowers being flat and broad, whilst those of the *Perpetual* are orbicular. Unlike the *Neapolitan*, the common blue will not agree with the slightest forcing: the *Perpetual* never requires it. In pots, it will bloom splendidly in windows and greenhouses; it will also do admirably in a sheltered raised place out-of-doors, where it can have temporary protection in bad weather. Of course it would do better still in a frame or pit. The flowers are not, in general, very large, but they are produced very abundantly, and are very sweet. All Violets dislike stagnant moisture. Where other conveniences are wanting, they flourish at the foot of a wall, or fence, facing the south, south-east, and south-west, provided you have either a wide board, or a narrow straw-thatched hurdle, from fifteen to eighteen inches in depth, to place against them in wet and frosty weather. For *propagation* and *culture* in frames and pots, see *Neapolitan*—only, if bulk is desired, the first-formed runners may remain, as in a fine summer they will be sufficiently matured to bloom along with the mother or principal head. The soil should also have more loam in its composition. Mr. Tiley advertises a *Perpetual Tree white*: the common double white is a poor thing in winter. If this *Perpetual white* is at all equal to the blue in this respect, it will be invaluable where there are ladies. I have not yet tried it.

Forming Tree Violets.—This is best done by dividing plants two or three years old. A nice little head, with a fair supply of roots, and a clean stem between them a number of inches in length, are thus obtained. Whether these are planted out-of-doors, or potted, the stems must at first be supported by little sticks. The head soon takes an upright direction. Ere long, the stem increases in strength, and also in length little by little every year. When once potted, and valued for their singularity, care must be given to supply them with plenty of water, and an open airy place in summer, and to avoid all stagnant moisture in winter. Sour earth about the stems will make them *miffy* and short-lived. Even when not shifted every year into larger pots, the drainage should be examined, a little old soil picked away, and fresh surfacings applied; and round the base of the stem a little cone of bruised charcoal will be a safeguard. I had them thus grown of all varieties, one of the best was a *Neapolitan*; but I got tired of them: I saw little beauty in the bare stems, and, from a pot similar in size, I could get many more flowers from a plant grown in the usual way. Allowing the runners to festoon from the top for several generations, like an *Aaron's-beard* Saxifrage, seemed an improvement, where all was so *stilted*; but to carry out that idea in a moderate-sized pot pre-supposes considerable attention to rich surface-dressings and manure-waterings.

3. RUSSIAN VIOLET AND SUPERB VIOLET.—These are extremely useful single Violets; the latter larger than the common. They are easily propagated by seeds, runners, slips, and divisions, and should never stand long in one place, as young plants generally bloom most freely. They are seldom potted, but they are worthy a place in the cottage window, where they could stand outside in fine weather, and be brought inside in sleet and frost. They will bloom very freely, where sashes and other covering can be given them in winter. In common seasons, they thrive and bloom tolerably well on raised banks, by the side of fences, &c., where a few branches,

or other covering, may be given them in severe weather. From October and onwards, a few rows of them perfume a garden. I understand something grand in this way is looming in the *near*. A deep, loamy, well-drained soil is that in which all the varieties I have met with in this section delight. If the soil is light and sandy, and tolerably rich withal, the number and size of the leaves will keep the flowers in the shade.

4. THE DOUBLE BLUE AND DOUBLE WHITE.—The last is the most tender. Unless in very mild winters, neither of them flower much until spring. For fine effect, propagate and cultivate the same as the *Neapolitan*, by runners, slips, and divisions. As flowers are produced on the first-formed runners, as well as the crown, they may remain several years in the same ground, but the flowers are likely to get less and less in size. A rich, deep, dry loam is their delight. In such circumstances, the bloom from strong young plants is truly fine. In sandy and chalky soils the plants run too much to leaf. Need I mention again, that the blooms of all, when dried, long retain their scent. R. FISH.

CONIFERÆ.

(Continued from page 126).

JUNIPERUS COMMUNIS (The Common Juniper).—This species is a native of Britain, and the colder parts of Asia and North America, growing, under favourable circumstances, to the height of ten or twelve feet, forming then a thickly-branched and not inelegant low tree. Its perfect hardihood recommends it for all open and exposed situations, where few other plants would exist. There are several varieties, some of which far surpass the original species in beauty—namely, *Juniperus communis Canadensis* (The Canadian J.), a dwarf bush from three to five feet high; *Juniperus communis Cracovia*, found near Cracow, a handsome, upright-growing variety; *J. communis Hibernica*, and *Hibernica compressa*, the Irish Junipers; these are also upright-growing varieties; the latter, as its name imports, being very much compressed in its habit; *J. communis oblonga*, and *oblonga pendula*. The latter is a very elegant drooping variety. Both attain the height of ten feet, and are natives of China and Japan. And, lastly, *J. communis Suecica*, the Swedish Juniper, a well-known favourite variety. It is said that in the forest of Fontainebleau this variety has attained the height of fifty feet, and various articles of furniture are made of its timber. I mentioned this fine variety in my notice of Alton Towers; and as it is fifteen years since I saw them, and they were then eight feet high, I suppose they will be now nearly double that height. Why do not we plant this tree for timber, as its wood is so excellent for cabinet work? It is cheap enough—twenty-five shillings will buy a hundred of them a foot high at the wholesale nurseries.

J. DRUPACEA (The Drupe-fruited J.).—Native of the plains of Syria, where, in almost all sand, it thrives and attains the height of ten feet.

J. EXCELSA (The Tall J.).—This handsome species is a native of Siberia, the higher parts of the Himalayas, and North America. There it often rises to the height of forty feet, but the highest I have seen in this country was fifteen feet (see page 144). The timber of this species is excellent. There is a dwarf variety called *nana*, and in gardens *religiosa*, being used in some parts in sacrifices, on account of its aromatic qualities when burning.

J. FLACCIDA (The Weak J.).—This is a curious species, with a slender, elegant habit. Being a native of Mexico, it requires a greenhouse or conservatory to grow it in. The leaves are lance-shaped, and the branches are drooping; it grows to a great height.

J. FRAGRANS (The Sweet-smelling J.).—From Nepal; also rather tender. Very little is known of this rare species.

J. GOSSAINTHANEA.—This is a rare species. I saw several fine plants of it lately in Mr. G. Jackman's nursery, near Woking, in Surrey; and, from the habit and colour, I should say it will be, when better known and more full grown, a most elegant tree. It is perfectly hardy.

J. LYCIA (The Lycian J.).—A native of Greece, the Levant, and Siberia; a handsome species, growing fifteen feet high.

J. MACROCARPA (The Large-fruited J.).—I have seen some fine specimens of this silvery-leaved Juniper, and can confidently recommend it as a very ornamental species. The cones are of a pale blue when young. It is a native of Greece, where it is highly esteemed, and planted freely.

J. MEXICANA (The Mexican J.).—The branches of this Juniper are unlike all the rest; they spread out at the base, regularly shortening in upwards, and thus form a handsome pyramidal tree, some 40 feet high. Unfortunately it is too tender to bear the open air in winter in this country, but it is well worthy of a place in a lofty conservatory.

J. NANA (The Dwarf J.).—This small bush is found in Europe, Asia, and North America. It has more synonymes than perhaps any other species. It is the *J. alpina* of Ray; the *J. montana* of Aiton; the *J. communis nana* of Loudon; the *J. communis alpina* of Woblenberg; the *J. communis saxatile* of Pallas; and the *J. minor montana* of Bauhin. It is Willdenow that has named it simply *J. nana*, the name I have adopted; and a more expressive one need not be; it is truly a dwarf, seldom reaching, even when old, more than a foot high. It is useful to plant at a corner where two walks separate, or close to the walk of the Pinetum; arranging well with such plants as *Abies danbrassiliana*, *J. sabina prostrata*, and such-like alpine, low-growing Coniferæ.

J. OCCIDENTALIS (The Western J.).—This species, in its native wilds, is a giant among its kindred, rising to the altitude of eighty feet, forming a noble tree. It is found in great quantity on the higher part of Columbia, where it is greatly esteemed as a timber-tree. No doubt, when more plentiful, it will be grown extensively in this country, both for its beauty and usefulness.

J. OXYCEDRUS (The Thorny Cedar, or Brown-berried J.).—The species is confined to Europe. It is grown largely in Spain, Portugal, the south of France, and in Italy, and has been grown in Britain for more than a century. It is a very low tree, seldom exceeding twelve feet. There are three varieties, namely *taurica*, *echiniformis*, and *Witmanniana*. They are all handsome, and should be in every collection of any note; but in the northern parts of this country they are rather tender.

J. PHENICEA (The Phœnician J.).—Native, as its name imports, of the south of Europe. It is also found in Russia! and grows from fifteen to twenty feet high. A beautiful, light-green-leaved tree.

J. PSEUDO SABINI (The False Savin).—Native of the Altai mountains; growing much in the style of our common Savin, but more upright, and rather lighter green.

J. PYRAMIDALIS (The Pyramidal J.).—Not much is known of this species; there is a plant so named in the London Horticultural Society's garden at Chiswick.

J. RECURVA (The recurved Nepal J.).—A very distinct species, with both leaves and branches turned back, or recurved; the foliage is light green. It requires a dry soil, is perfectly hardy, and very ornamental in sheltered places. Exposed to the north winds it is apt to turn rusty in winter, much in the same style as the *Cryptomeria japonica*. The variety named *densa* is a

distinct one, and of more dwarf, compact habit. Both are very desirable.

J. SABINA (The Common or True Savin).—Grown in masses, this species has a fine effect. In favoured situations it will form almost a tree. Clothed with a rich brown bark, the dwarf variety, *prostrata*, is well adapted for rockwork, or to place on a lawn to form a sort of fringe to the shrubbery. The one with variegated foliage is pretty, and worthy of a place in a collection on that account.

T. APPLEBY.

(To be continued).

THE PETUNIA.

(Concluded from page 145.)

GENERAL MANAGEMENT OF PLANTS INTENDED FOR EXHIBITION.

It is well known to those cultivators who grow plants with an especial eye to show them for competition, that extra care and attention is required in order to beat their opponents, or, even if no opposition is offered, to win the approbation of the censors, and, consequently, a prize. Most societies give directions in their schedules to the judges not to give first-class prizes to inferior specimens, merely because they are the best exhibited, or, perhaps, the only ones present on the tables. This is quite right, and relieves the censors from a most unpleasant part of their adjudication. It is true, there are exhibitors selfish enough to argue, that as their productions are the best present they ought to have the prize offered for the best; but if such confessedly poor things were to have first prizes, the subscribers and visitors would be disgusted; there would be an end put to that spirit of emulation and desire to excel which ought to be the aim of all exhibitions to encourage and bring into play. Then again, such a law will prevent any competitors from bringing to the exhibition any fruits, plants, or vegetables, that are not, at least, respectable, and show that some extra care has been taken to bring those exhibited, at least, superior to the commonly-seen specimens in every garden.

These remarks will, I trust, be taken with candour, as I do not see how any one at all conversant with exhibiting matters can deny their truth; and I would advise every one showing garden productions never to exhibit any article but what is in good, fair condition. To do otherwise ought only to bring disgrace, and not honour or credit to the exhibitor.

THE PETUNIA is no exception, but must be well grown, and freely and finely bloomed, in order to be considered worthy of a prize. The way to manage so as to attain so desirable an end is my business, on this occasion, to describe. The time to exhibit them to perfection is about the last week in June (which is early) to the last week in July, which may be considered, in the generality of seasons, to be late.

Plants intended for this purpose should be well established the preceding autumn, and should not be allowed to flower till within a month of the time of exhibition. They may be kept in pots from three to four inches diameter through the winter. From the first moment of potting, up to the month of May, they should be frequently topped; that is, the two upper leaves, with the buds attached, should be carefully and neatly cut off with a sharp knife. Nipping off with the finger and thumb I cannot approve; it is, to say the least of it, a careless method, and crushes and mutilates a plant in the tenderest part, often causing many of the shoots to mould and perish in wet, damp weather; whereas, a clean cut with a keen-edged knife heals up quickly, and the plant is little worse by the operation.

As the plants grow they must be repotted as soon as

the roots reach the sides of the pots. They should never be allowed to become matted till placed in their blooming-pots. In March, it will be necessary to provide a number of short sticks; if they are painted a light green so much the better. At one of the spring pottings, before the roots have pushed into the new earth, thrust a circle of these sticks round the pot at some distance from the shoots; tie a short piece of nice small bass-mat to one of these sticks, so that the two ends of the mat are equal in length from the stick, then bring each end round a branch nearest to the stick, and, with the mat, draw it gently down to the stick, and tie it to it rather loosely. This is a nice operation, and requires a steady hand and attentive eye, or the shoot will break off from the main stem. When one branch is securely and safely tied, proceed to the next, and so on round the plant till every side-shoot is brought down, and the centre left thinly furnished. Cut off the ends of all the strong shoots, and the plants will soon begin to show they have had a careful hand at work to form them into bushy, round-headed specimens. This is the ground-work to commence with, and as the shoots advance in number and length must be repeated, and longer sticks made use of. If the shoots are too numerous, let them be judiciously thinned, so as not to allow them to crowd each other. The short sticks may be removed when the shoots do not require their directing support. As they advance towards blooming, they may require a few sticks in the centre of each plant to train each shoot into a position so as not to interfere with its neighbour.

The management as to potting, placing in a pit, smoking with tobacco to destroy the green fly, dusting with sulphur to destroy mildew, watering with liquid-manure, giving air, and other points of culture, I have already described under the head "Summer treatment." To these directions I have nothing to add now. If the cultivator has been successful in his operations, the plants for exhibition will, in May, be strong, bushy plants, eighteen inches high, and twelve inches through, and be showing plenty of flowers, which may then, if the show is in June, be allowed to come into bloom; but if in July, the buds must be taken off again, and not allowed to remain till the middle of June. All the energies of the plant must be reserved, in order to have a blaze of fresh, high-coloured blooms on the day they are required for the exhibition table.

T. APPLEBY.

INFLUENCES OF THE WET SEASON ON CROPS OF VARIOUS KINDS.

THE near approach of winter renders it necessary to take such precautionary measures as will protect the various products which hard weather is likely to injure. This is the more advisable, in consequence of the unusually wet autumn having rendered everything out-of-doors a perfect receptacle for water, the tissues or cells of plants being charged with water almost to the bursting point. It is easy, therefore, to perceive the effects that frost is likely to have on plants so gorged with superfluous moisture, which has scarcely ever been relieved by a dry day, nor yet (what is equally useful) a cold one. The atmosphere has been, in most cases, mild and warm for November, while the ground has been so repeatedly soaked with drenching rains, that, in spite of the absence of cold and frost, the autumn growth of many things has been much below the average of years. This is apparent to every one in the after-harvest-sown *Turnips*, many of which scarcely present anything more than the same mass of green leaves that they did two months ago, and that this tardy progress is owing to the cold, drenching rain is evident to every one; since the average atmospheric warmth, if fully equal to

former years, when the various members of the numerous *Cabbage family* continued their growth with more steadiness, if not with more vigour, than they sometimes do in the summer months. Now these perishingly cold rains have been more hurtful to the late-planted *Celery* than most crops, some of it will not arrive at the size and condition fit for blanching; while in former years, and under precisely the same treatment, the late-planted has carried on the supply in the spring, when the larger and earlier was no longer fit for use. This season it will only be fit for the commonest purposes to which green *Celery* is put. This state of things is the result of the long-continued wet weather we have had, in which the herbage has rarely ever been dry, and the ground soddened to the utmost with rain. Even grass, which is supposed to resist, nay, even benefit by the usual autumn rain, has, this season, made less growth since the end of September than is usual with it. Under such a state of things it cannot excite surprise if the more delicate portion of garden produce should have made but a tardy autumn growth. Young seedlings of the *Lettuce* or *Cauliflower* tribe, even where protected by glass, have scarcely been able to resist the decaying influence of such a protracted season, while a considerable portion have absolutely perished under it. The obvious tendency of so early and wet an autumn is to prolong the winter by lengthening its advent. In a usual way, we have more or less of moisture before severe cold sets in, and hardy plants are but seldom perfectly dry during November; but in the past season October has been substituted for that month, so that the horticultural autumn may be truly said to have "set in" a month sooner than usual.

It will be difficult to find a remedy for such a state of things, but many palliatives will suggest themselves. It will now be discovered to what good purposes efficient drainage may be applied; and if such do not already exist in our gardens, the present time must point out the necessity of making it so. The utility of tanks, channels, and all watercourses will also have been put to a severe test, and their purposes proved. Coupled with these is the quality of walks, roads, and paths, which a series of wet weather, if accompanied with traffic, soon finds out their defects. All these, and many more evils resulting from such drenching rains, have so far retarded the usual autumn work, that we must urge on our brethren to be on the alert when a change does take place; and all house-work being, as we expect, advanced as far as possible a-head of the season, and others, to which the inclemency of the weather offers but few impediments, must be pushed on as far as possible, in order that the general outdoor work may receive the united energies of the whole staff, when the period does arrive to bring it into action. A thoughtful business habit of contriving work will suggest many things which can as well be done in wet weather as in dry. We therefore advise our young friends to cultivate this useful part of their studies, as much may be gained by it.

Among the plants suffering from the absence of sunshine are the winter *Cucumber plants*, which, though in an atmosphere purely artificial, are not yet exempt from the causes which prove fatal to more robust productions out of doors; as, apart from the want of that all-important element of their existence, "sunshine," the atmosphere of hothouses is, or must be, more or less charged with that moisture which reigns everywhere. It may be true that a dry heat applied removes or drives off part of the water, but then it substitutes a temperature in its place ungenial to vegetation. That this is the cause of many disasters is too well known; nevertheless, there is no other way, and those who have young *Cucumber plants* struggling against the elements must act very carefully with them. Avoid, by all

means, "drip," and if the house or pit where they are growing be flat-roofed, or of low pitch, drip will invariably be the consequence. A homely, but useful protection to small plants is to suspend (from the roof) a large-sized bell glass over them; observe, this must be some height above the plant, so as to leave it in possession of the whole atmosphere of the house to breathe in, or a few large squares of clear glass placed in a steep slanting direction over them, and on their north sides is also useful, as it catches the drip from the roof on its outer surface; while its inner one, we expect, is too steep a pitch and too smooth to allow what moisture collects there to drip on the plants. Nevertheless, with all the care that can be taken, the progress at this untoward season is but tardy; still they may be carried through, and we advise our young friends to keep a vigilant look out for mildew in some of its forms. This is more especially necessary, as this plant cannot endure those forcible means made use of to eradicate it. From more robust subjects, the first approach of it must be instantly checked by rubbing over the spots with a soft brush dipped in lime-water, and a little quick-lime may be brought into the pit. The gas emitted by sulphur is too much for this plant. We need hardly observe, that all plants likely to introduce insects of any kinds must be kept carefully out of the way, as the means necessary to destroy these intruders is an ordeal too severe for this delicate subject, which, at this untoward season, requires more than the usual amount of nursing to ensure anything like a successful issue. Heat must be steady, and means taken so to balance its humidity as to be congenial; from 65° to 70° is about the proper temperature. But I will return to this subject at the first early opportunity.

J. ROBSON.

GREASING THE WHEEL.

By the Authoress of "My Flowers," &c.

It was a word of advice from the wisest of men, "Boast not thyself of to-morrow; for thou knowest not what a day may bring forth." Who among us lays this advice to heart? Who among us has holy boldness enough to say, as St. James directs us, "If the Lord will, we shall live, and do this and that?" Who among us but looks forward, and expects, at least, not only length of days, but continuance of all the blessings we possess? We may not boast, perhaps, but we *presume*. We do not consider what a day may bring forth; we do not think about it; we have had good health, *good luck*, no accidents; and we forget whose hands fashioned us, and from whom we receive and hold the breath of life. Whichever of my readers can feel a humble, blessed consciousness, that such is not *their* case, happy and highly favoured is their state! Many there are, many more may there be, of that blessed band! They alone dwell in peace; they alone are watching and ready, when the hour of trial comes. Those who think little or nothing of the uncertainties of this world are careless and daring in their conduct. One would think that a man who rests upon *good luck*, or upon the fact of never having met with danger and accident, or who never troubles his head at all about how or why he is alive and well, would, at any rate, take common care of himself, and not run foolish risks to put himself in the way of mischief. But this is seldom the case; and such fool-hardiness is seen among men as makes us almost suppose they are without reason, as well as without God in the world.

A few weeks ago, an instance of this fool-hardiness took place in a neighbouring parish; and I hope it may be a warning to some of my careless readers to avoid such dangerous acts; for in one little moment an affliction may be brought on that will cause us distress and suffering for the rest of life.

A farmer was engaged in thrashing out corn with a thrashing-machine. It was a singular circumstance, that one morning, one of the men employed on the farm went to his master,

and said, "Sir, I had a very strange dream last night. I dreamed that one of us had our hand smashed in the 'chine." Of course no notice was taken of this, except, perhaps, a smile; but the man himself thought a good deal about it, and kept as much at a distance from the machine as he possibly could. In the course of the day the wheel wanted greasing, and the farmer's head-man, or bailiff, prepared to do it. The horses were going on; and on being spoken to of the danger, the bailiff said, "Oh, I can't spare the time; I can do it while they go on; I can't waste time while I'm greasing the wheel." So on went the horses, and the bailiff crept between them to the axle of the machine, where the grease was to be applied. The man was very careful of his hand as he put the grease in; but while thinking of the one, he totally forgot the other. His left hand was thoughtlessly placed on a part of the machine, which caught it, and crushed it in an instant! Bleeding, and in agonies, the poor man was taken up, as soon as the horses could be stopped, and carried to bed. The surgeon was summoned, and gave it as his decided opinion that the hand must be taken off and part of the arm also. The poor fellow was so distressed at the idea of losing a hand, which supplied him with bread, that he begged for further advice, which was cheerfully granted; and he chose the surgeon whose opinion he should like to have. He came; but alas! there was no hope; the hand must be taken off just below the elbow; nothing else could possibly save his life. The operation accordingly took place; and the man, who rose up in the morning in health and strength, and began his daily work with all his usual vigour and light-heartedness, when evening closed in lay on the bed of suffering, deprived of a limb, and disabled for ever from gaining his bread in the way in which alone he was fitted to do it. One moment's heedless folly has brought the bitter repentance of a whole life. The five or six minutes, which could not be spared to take a wise and rational precaution, have caused days and weeks of suffering, of loss of time, and of heavy self-reproach—hardest of all to bear. What must be the thoughts of a poor man, lying helpless and crippled for life, when he thinks that his own mad stupidity has laid him there? When he thinks that he needed not to have done so foolishly—that the very boy who was driving the horses must have known his danger, and would not have done the same? Oh, how he must mourn and lament, and *wish* he had not been a fool, when it is too late; when his poor crushed hand is off and buried, and nothing can be done but to bear the loss, and pray for grace to profit by the lesson, and that the trial may be sanctified to him!

I hope and trust that this poor man's accident may be a warning to those of my readers who are headstrong and daring. Every day of our lives we see instances of thoughtless, reckless risk; and, perhaps, few of us have not been guilty of some one or more ourselves. It is not weak or wicked to be cautious: it is so, when we persist in doing a dangerous thing which need not be done. It was not duty that obliged this poor fellow to grease the wheel while the horses were going on; nor is it duty that leads us often into mischief. We are very well aware that we are ready enough to get away from duty when it leads us into perilous places; we can often find a good excuse for escaping *then*—for being prudent and cautious *then*. It is our own self-will and hot-headedness that runs away with us, and gives us reason to repent, often to the end of our lives.

I must say a word more upon this occurrence, before I address a startling question to my readers. The dream—it was a striking and remarkable one. Such things have been before. We know that under the Old Testament dispensation God appeared unto men in dreams, and many wonderful events were revealed in visions during sleep. But those days have passed away; and we have no Scriptural warrant for expecting revelations by means of dreams. Still, the Lord works in whatever way He pleases; and without ignorantly and blindly attending to our dreams, as many do, we would not totally set them aside, or laugh contemptuously at them; for what the Lord has used as an instrument to work His will should be no matter of scorn to us. In this case, the fact occurred, and I do not ever remember to have heard of so striking a coincidence before.

And now, one question before I close my paper. How are we greasing *our* wheels? We are all pressing forwards to *something*; but are we greasing our wheels for time, or for eternity! If we cannot spare time from our earthly business to seek "the kingdom of God and his righteousness,"—to take "oil in the vessels with our lamps,"—we shall lose that which is worth more than a right hand—we shall "*lose our own souls*." We shall find ourselves caught and entangled in a snare that will crush us to all eternity, from which there is no deliverance and no hope. We shall look back from the bottomless pit with weeping and wailing and gnashing of teeth, upon the senseless folly, the raving madness, that chose "the pleasures of sin for a season," instead of the lasting glories at "the right hand of God."

Readers! we are all of us thrashing; thrashing for time, or for eternity; and One speaks to us in plainer words than those of a dream, "Repent, for the kingdom of heaven is at hand." Let the poor bailiff, on his sick-bed, teach us a mighty truth. We may be "in the morning like grass that groweth up;" in the evening "we may be cut down and withered." Let each of us ask our own heart this great and startling question—How are we greasing *our* wheels?

A FEW OF THE BEST DAPHNES.

In order to give an account of these, I must include the *Daphne odora* and its varieties, for these are beautiful, and deserve for winter nosegays a place wherever room can be spared for them. They are excellent to plant out in large conservatories, where they are just at home, although almost hardy enough to stand out under a warm wall or corner, with a little protection during severe weather in winter. They do well, also, wintered in a pit or frame, where the plants are not too large for such places.

This species generally begins flowering in January, and continues more or less in flower until May. No plant is more desirable for nosegays; it is so very sweet, and continues so long in perfect beauty after being cut for this purpose. I have no doubt it would be rooted very well from cuttings by those who have proper places for this work, but they are more commonly grafted upon the common spurge laurel, *D. laureola*. Several years ago, when I first saw the variety, *D. odora rubra*, I was so much struck with it, that of course I wanted it in some way or other, and my friend who possessed it said, I have young plants of the *D. laureola* in pots, and I will put you on one graft; he did so; he took off a scion with two crowns or a forked top, and inserted it into the pot by the side the stock it was to be worked upon, and inarched it to the stock just below the fork, and placed it in one of his heated pits, where it soon united; and the plant came to my hands with its forked top, and standing upon two legs as it were. It so stands now, and a fine specimen it is, too, but the stock on which the scion was inarched is but a very little larger now than when the scion was put on, whilst the scion is nearly three times the size of the stock at the present time. I am not inferring from this circumstance that many of the *Daphnes* might not be raised from cuttings, for I have known the *D. pontica*, and others, to be raised from cuttings, thirty years ago, under a north wall, under hand-glasses.

There is another variety called *D. odora variegata*; but I consider *D. odora rubra* the best.

The *Hardy Kinds* are as follows:—*Daphne hybrida*, or, as it is most generally known by the name of *D. dauphinii*, Dauphin's *Daphne*. This is one of the most desirable plants that any garden, great or small, can possess. It is a beautiful plant to grow against a south wall or warm corner. It does well as a shrub in the open border, and from the goodness of the plant, it is worth a place, planted out in a conservatory, where it would be seen in bloom nearly the whole year, more or less.

We have a large plant of this upon a conservative wall covering a space of about five feet by five to six feet. It is not nailed in like a Peach-tree, but just fastened up, sufficient to secure it firmly to the wall, with a fine thicket of breastwood over the face of the whole tree, protruding about from six to nine inches from the wall. It seldom requires any pruning more than it gets by being so much cut for nosegays, as its flowers are very sweet-scented. Nearly

every shoot over the whole tree terminates in a bunch of bloom of a purplish-red colour, and the whole foliage is of a dark shining-green colour. It commences flowering in September, and continues in bloom, more or less, until the end of April. Ours is a perfect gem at this moment (Nov. 20th). I was, with a friend, a few evenings since admiring the beauty of this plant, and to see the moths flying from flower to flower (mostly of the *Phalena gamma*, or the Greek G. moth-kind) proved that they admired its sweetness too.

This shrub was planted out here the spring following the severe winter of 1837-8, and has never been protected. I believe it is nearly as hardy as the *D. laureola*, on which it is grafted. When the weather is very severe, it causes some of the blossoms to fall off; yet, after a change again to a south-westerly wind and a few showers, the tree looks as gay as ever.

Daphne cneorum.—This is well named "the Garland flower," and a prettier little hardy plant does not exist. It should always be a front border plant when planted out, and have as nice, open, sunny spot as can be given it. It is often grafted, like others, upon the *D. laureola*, and small plants of it look very pretty in this way, either in pot or planted out. It may be planted out in almost any good garden soil when grafted on the *laureola*, but when the plant stands upon its own roots it should be planted out in peat, in a dry, warm, sunny situation, which makes the finest specimens to stand the test of years. I do not know how many legs of *D. laureola* it would require to bear up a specimen we have of this beautiful plant on its own roots, and many rooted plants might be taken from it if required, for the outer stems, as they come in contact with the earth, put out roots readily, consequently it is increased easily by layers. There are two varieties of this plant, namely *Variogata* and *Grandiflora*. Both the species and its varieties are equally beautiful. It commences flowering in April, and continues oftentimes more or less during the summer months, of a beautiful reddish-pink colour, and very sweet-scented. The flowers keep perfect a long time after being cut for nosegays, for which it is so very desirable.

Daphne pontica is a very desirable kind as a front shrub in the plantation, or as a bunch or group by itself. Low ground, or a cool situation, suits it best. Indeed, it does very well under the drip of other trees, and also best upon its own roots in such places. It grows too straggling and rampant to be grafted upon the *D. laureola*—though grafted plants are all very well for a few years' growth of any of the kinds. The stems of this species, as they come in contact with the earth, put out roots freely enough, so that, of course, it is readily increased by layers. The whole plant is of a pale-green colour, rising from two to three feet in height. Its flowers are numerous, and of a yellowish-green colour, and very sweet scented. It flowers in April and May.

Daphne Mezereum, commonly called Mezereon, has two varieties, the white and dark red. Though a native of our own woods it is none the worse for that. These are plants of very pretty growth, suitable as front plants to the plantation, and, as a poet says,

"Though leafless, well attired, and thick beset
With blushing wreaths investing every spray."

These plants are increased by seed, and require a good sandy loam. The ripe berries look very tempting upon the plants, but they are poisonous. The Mezereon is one of the first shrubs to be seen in bloom in the plantation. February and March is its time of flowering, and, if not the only shrub then in bloom, it will for certain be the most showy and the sweetest.

Daphne Collina, *Neapolitana*, and *Gnidium*, and several others are grafted upon the *D. laureola*, and, as shrubs, are very well where the number of kinds is the consideration.

The *Daphne laureola* is itself a particularly useful plant to live, flourish, and flower under the drip of trees, and in the shade where few other things will live.—T. WEAVER.

CROSS BREEDING OF FOWLS, AND CURE FOR THE ROUP.

I HAVE read attentively nearly all papers that have appeared in THE COTTAGE GARDENER relative to that now

"fashionable subject, the Cochin-China fowl and its rival the Spanish;" and throughout the whole I find each advocating the cause of his favourite bird too frequently by vague assertion or "mere fancy." The table by "Gallus" is not at all satisfactory; it would require that the same number of fowls of each kind and sex be kept together for a considerable length of time—say twelve months—the food they consume weighed, and the return they give in eggs also weighed; we could then come to something like a correct estimate of the relative value of the different kinds. But at present one asserts "the Spanish lay larger eggs, and are more profitable to keep in consequence of consuming much less food;" another affirms "that Cochins do not eat more than Spanish or Dorking," and that "their frequent and pertinacious desire to sit is their only drawback."

The Cochins, on all hands, are allowed to be very productive, but their very great desire to hatch is a failing in the breed. The Spanish, on the other hand, are seldom or never inclined to sit, and lay eggs of a much larger size. Now, it appears to me that a cross between the Spanish and Cochin would be the very perfection of fowls; and a breed of fowls may be raised between them combining the good qualifications of both, just as you, Mr. Editor, would take the pollen from one flower, and put it in another. Take an instance: If I had a fine *formed* flower of a colour which I was desirous of altering in its progeny, what would I do? I would look about me for the best-formed flower of the colour I wished, and impregnate with this pollen my favourite-formed flower, and the probability would be that I should obtain some of the desired colour, and equal in form to its female parent; and, reasoning from the world of flowers to the world of animal life, I would find the same general law to hold good in both. "But, ah!" says the amateur, "I'll have no mongrel race; I'll have nothing but pure breed." Now, I do believe this to be a great mistake. How, I would ask, have we improved our breed of cattle? Is it not by breeding with those animals who have what we want in greatest perfection, and by following it out that we find them in the improved state they are now in; and I cannot see why the breeding of poultry should be an exception.

I have been led to make these remarks in consequence of having last year a chicken from a cross between a Poland hen and a Cochin-China cock. It turned out a hen, and began laying in the beginning of January last (being only hatched in July), and laid, on an average, five and six eggs a-week until the end of March following, when she manifested a desire to sit, and was then set on a dozen Cochin eggs, eleven of which were hatched by her; and *before the chickens were three weeks old* she had begun laying again, and has continued doing so, I may say, almost without intermission ever since; for when she showed an inclination to hatch again, a single day, or two, at the most (very different from Cochins), in a crib, put the fever off, and in eight or ten days she was laying again. She moulted about a month ago, and was scarcely finished moulting when she began again to lay; and although she may not lay so many days running as Cochins, still I have no doubt she lays within the year a greater number, and the eggs are considerably larger. I have two pullets this year from the same hen and a Cochin cock, which seem to promise equally well; and in the spring of next year I mean to try a cross between a Spanish cock and a Cochin hen, and I have no doubt that the progeny will be larger and stronger than the Spanish; and the number of eggs will be increased from the productiveness of the Cochin, and "the pertinacious desire to set" will be lessened by the Spanish, and altogether a better fowl will be produced for profitable purposes (and that is what is really wanted) than what either will produce separately, and all my observations on the breeding of fowls confirms it.

I have kept fowls for several years, but have never known what disease was, until this season. A disease (I am at a loss to give it a name) has seized on nearly all my young broods when about half or three-parts grown, and several of them have died in consequence—wasting and pining away. The trouble, to all outward appearance, being in the head. The first thing that strikes one is the ruffled state of their feathers, afterwards a discharge from the nostrils, and as the disease advances, the head, between the eyes and the

bill, swell up in small pimples nearly the size of a small pea, and very frequently a kind of froth is seen working about over the eyes. After being from home for two or three days, I found one with the disease in a very advanced stage, and on taking it up in my hand it appeared little heavier than the bones and feathers should have been. I took the little sufferer and washed all its head about the nostrils with soap and milk-warm water, and dried it with a cloth, gave it a little toasted bread steeped in tea, part of which I had to put down its throat, being so blind it could hardly see. Having before tried everything recommended in book, and many things beside, without effect, I again tried as a change (thinking it very probable the bird would die at any rate) some iodide of potassium. I dissolved ten grains in an ounce of water, and having taken a small piece of loaf-bread an inch square, and half that in thickness, I dropped some of the iodide on the bread, say about sixty drops, and gave it. Next morning I again washed it with soap and water, and dried it, gave it a few grains of corn, which it either could not see to eat, or did not feel inclined to do so. I then gave it a little toast steeped in tea, as before, and concluded with giving it the same quantity, as before, of iodide, and in the evening I repeated exactly the same, toast and iodide. The following day it was decidedly better, and ate the little corn I gave it evidently with a relish, after which I gave it the toast and iodide, and continued that treatment for about a week, when I put it out with the other fowls, and only occasionally afterwards giving it a little of the same medicine; in about a fortnight to three weeks it was as well as any fowl in my walk. Since then, I have treated many of them in the same way, for the same disease, and since having done so, I have not lost a single fowl, and I shall be glad if it be found to be as useful to others as it has been to me. I have found cream-of-tartar the best laxitive medicine for fowls, and have almost always ended my cure by giving them a little; as much as will lie on a sixpence, for a full-grown fowl, is a sufficient dose.

If you think the above remarks of use to any of your numerous readers they are at your disposal, and you may hear again how my other cross-breeds succeed.—A. S. W., Glasgow.

EATABLE FUNGI.

(Continued from page 110.)

THE *Hydniums* form another genus, most of which are eatable, and several highly esteemed as food. *Hydnum erinaceum*, which is found growing upon old oaks, forms a common article of diet in the Vosges, a range of mountains separating Lorraine from Alsace. *Hydnum coralloides* is eaten in Piedmont and Tuscany. *H. auriscalpium*, which is indigenous to this country, and found growing on fir canes; and *H. leoninum*, a native of Sweden, are also eatable. *H. album*, has somewhat the flavour of the Cantarille. *H. repandum*, however, is the one most generally esteemed, and is reckoned amongst the most delicate fungi of Italy. In preparing it for the table, being a very dry fungus, it requires to be cooked for a long time, or it is tough; but when well stewed in rich gravy, it forms an excellent dish, and has a slight flavour of oysters.

The *Boletuses* form another genus, which, although including poisonous species, contains also many that are valued as an article of diet, as much, if not more, than any previously mentioned. So highly, Dr. Badham says, is the *B. edulis* esteemed, that gold, and silver, and dresses, may be trusted to a messenger, but not this *Boletus*, because he would eat it on the road! Perhaps no genus of the fungi supplies such abundance of food to so large a proportion of the population of the globe. The species are generally of large dimensions, and are found in immense profusion. *B. edulis* is the easiest cultivated of all fungi, and is found growing naturally almost in every locality where an oak-tree or trees exist, and *B. scaber* is almost as abundant. According to Drummond, many species of *Boletus* are used as food in Western Australia; and I have no doubt that those fungi seen by travellers, the dimensions of which equalled crouching lions, belonged to this genus. The *B. scaber* is a favourite amongst the Russians and Poles, who have many ways of cooking it.

In Hungary, a soup is made of *B. edulis*, and considered a great delicacy. In other parts of the Continent, many species, as *B. subtomentosus*, *B. granulatus*, *B. edulis*, *B. scaber*, &c., are brought into the markets, but, undoubtedly, *B. edulis* is considered by all as the best, and in my opinion, when fresh, is good eaten in any way. I have eaten it raw with bread and butter and enjoyed it. My experience, however, has taught me that it is best to remove the tubes of this genus before using them as an article of diet, as independent of their being watery, they have a hot peppery taste, and are very liable to be loaded with insects or their eggs.

With respect to dressing the *Boletuses*, more especially *edulis*, I quite agree with Dr. Badham, when he says it will improve any dish. I will give, however, the following recipes:—

Boletus edulis soup, as made in Hungary (Paulet). Having dried some *Boletuses* in an oven, soak them in tepid water, thickening with toasted bread, till the whole be of the consistence of a purée, then rub through a sieve, throw in some stewed *Boletuses*, boil together, and serve with the usual condiments.

Boletus edulis is also fine fried in fresh butter, served up on dry toast, and eaten with or without beef-steaks, the seasoning with salt, pepper, &c., left to the cook.

Agarics form the largest genus of the fungi, and produce many, both poisonous and eatable. I regret that space will not allow me to enumerate all its species, which, as is well known, have from time to time been used in different parts of the globe as food. The British I shall briefly notice here, as my next paper will be confined to the British fungi exclusively. The *Agarics* are dispersed in almost every region of the globe, affording to both savage and civilised natives an abundant supply of wholesome and nutritious food. On the Continent, and more especially in Poland and Russia, several *Agarics* are used and highly esteemed as an article of diet. *Agaricus translucens* has been reported to be eaten by the people of Montpellier, but it is a very watery mushroom, and must form a very indifferent food. *A. nivalis* is said to be eaten by the Tuscans, but I cannot recommend it as an article of diet in this country.

A. vaginatus is eaten largely by the poor of Muscovy, but cases are on record in which it has proved poisonous. *A. procerus*, which is known by many other names, is largely used throughout France and Italy. The receipts for dressing *Agarics* are numerous. I shall, therefore, only give a few which may be also found most useful for dressing fungi generally.

Fried Fungi.—The usual method of frying fungi is either in oil or fresh butter. The latter I consider far preferable, and served up in the following way:—When the fungi are nearly done, have ready some dry toast, place it in the frying-pan, and in a few minutes turn it, place the fungi on the toast, sprinkle them with a little pepper and salt, and when the toast is warm through, convey them to the table, and eat while hot.

Grilled Fungi.—Many fungi are far preferable grilled, but will require a little butter to prevent their burning, and may be seasoned as in the last, with pepper and salt; as, however, the essence of the fungus is often deposited in the fire in a liquid state, my experience has taught me, if the cook possesses good patience, and time is not an object, that toasting on a fork, or in a Dutch-oven, with many fungi, is far preferable, as in this way they do not get burnt, and the liquid is preserved.

Stuffed Mushrooms.—Take large mushrooms, full-grown, but remove the gills, and place in lieu of them the following stuffing:—Bacon shredded, crumbs of bread, chopped herbs, and a little garlic or eschalot (as for omelettes), salt, pepper, and a taste of spice. Broil in paper as a maintenance cutlet, moistening with butter when necessary.

Mushroom Dumplings.—An agreeable dish may be made from the common mushroom, by simply cutting up the small (or button) mushrooms, and forming them into a dumpling, with pieces of bacon the size of a dice, and a sprinkle of salt and pepper.

F. YORKE BROCCAS.

(To be continued.)

SHANGHAE OR CHINA FOWLS.

THIS fine sort of fowl has been often described, but I consider that amateurs have been rather too limited in their descriptions, and that their rules for the fancy birds of this breed are too narrow and restricted; so that many families of fine and pure-bred Shanghae fowls cannot be brought to submit to them; a short explanation of which I will endeavour to give.

First, then, "The beak should be short." Now, I do not notice that it is shorter in these than other fowls; but I think the front part of the head is longer.

Next, "The comb should be medium-sized, single, and straight," but I often see it bent from side to side, and occasionally slightly inclined to be double at the upper extremity, and often it is over the medium, and as I do not know of any other breed of fowls having this peculiar bent comb, so I see no reason why it should be objected to.

Then, "They should not be tufted." But were not some tufted, there would not have been any necessity for this rule, and it is very constant in some families. Some persons think these fowls descended from the great St. Jago fowl, which is described as often tufted, in which case I do not consider it right that the tufts should be objected to. Others seem to fancy they were obtained by the Chinese from some of the South Pacific Islands. Could any one throw light on this subject it would be interesting. They are described as having "double gills or wattles," but this I consider a mistake, as all I have seen have rather short, broad, single gills; the ear plates are, however, large, folded, and somewhat pendant, which may have given rise to the error. These are all points of the head, and I believe a fowl may differ in them, and still be a pure-bred bird; not that I should consider all of the imported fowls to be of the true stock. Again, I think fanciers have dwelt too much on colour, the dark birds being least prized; but I think them generally the heaviest fowls; and the buffs they endeavour to breed without black, not because it is the natural colour, but because it is difficult to be obtained; for the same reason the white are esteemed, though I think they will often be found to be somewhat the smallest. In the other points I heartily concur, and I think the most important consideration is weight; next shape, wide shoulders, full well-covered thighs, resembling a Dutchman's breeches; short, thick legs, and feather-footed. Long, lank, and narrow-made birds will occasionally be produced, but I should not keep them for stock. Others, which are admired by some, have no feathers on their feet, but I think the feather-footed birds approach nearest to the original type.

The tail is the best criterion by which to judge of the purity of the breed that I know of—this is always small, and though composed of the same number of feathers as those of other fowls, they are very short, scarcely reaching above the bunch of curled rump feathers, and the chickens attain to a large size before any tail makes its appearance, though the pullets sometimes get tails earlier, and a half-bred chick will sometimes be a long time before it has a tail.

A five-toed fowl I should look on with suspicion, although it might be perfect in all other respects. The productiveness of the Shanghae fowls is very great, the hens being good layers, close sitters, and laying again soon after hatching; the chickens seem hardy, and grow fast, though they feather slowly. The eggs, the shells of which are often dark-coloured, are good eating, and the young fowls are excellent for the table, being fine-flavoured and juicy. To this I can bear testimony, for having reared many more than I want for stock, and not having been able to part with them, I have killed several, and always found them delicious, much better in flavour than any fowl I have ever eaten, and though never cooped or fattened, they were in the highest condition.

The way to raise large fowls is to hatch them early, feed them well, and not to breed from relations. The gait of the male bird is peculiar, rather crouching, resembling that of a cock turkey.

They are a quiet fowl, not straying far from home, are easily kept within bounds, and seem to bear confinement well. I do not know why they should be called Cochinchina fowls, as they are brought from the more northern part of China, principally from the town of Shanghai and its neighbourhood.—B. P. BRENT, *Bessel's Green, near Seven Oaks.*

NORMANDY.

(Continued from page 112.)

THROUGHOUT France generally, and especially in the Departments of Calvados and La Manche, female accomplishments assume quite new and unexpected forms. Near Bayeux, I saw a woman on her knees by the roadside breaking stones; another, near Periers, was mowing some clover in a field, to take home to her quadruped, probably a horse, who was too tired to carry it himself; and in the town of Periers, I noticed a female postman—a *facteuse*, instead of a *facteur*—going her rounds to deliver the letters and newspapers. She had the usual tin box slung before her, but had dispensed with the glazed hat and the livery coat. At Sartilly, a lady was painting the wheels of a cart, while her husband was employed about finishing the body; and between Sartilly and Avranches, many women were to be seen lustily at work with the flail, threshing away with right good will and thorough good humour. One party, consisting of half-a-dozen threshers, was composed of five women and one man; and, as the diligence passed, they laughed, as if our appearance amused them quite as much as their's did us. It may be expected, that if women thresh, they also winnow; and female hands were flirting fans of a different description to those usually seen in ball-rooms, for they tossed and shook no trifling measure of wheat.

The harvest here is variously reported. The *Journal d'Avranches* for September 5, quoting the *Moniteur*, states, that "certain journals have published estimates as to the harvest of 1852, which would tend to make it supposed to be insufficient. These journals have been wrongly informed. The result of the information received by government is, that the harvest of 1852 will be, on the average, equivalent to that of ordinary years, and even superior, by nearly one-fourth, in certain departments, which furnish a great proportion of the cereals consumed in France." But the *Conseil d'Arrondissement* of Avranches, in reply to the questions put in the letter of *M. le Préfet*, dated August 12, 1852, is of opinion

1st. That the harvest of 1852 is inferior to the harvest of an ordinary year, for wheat and rye.

2ndly. That the amount of deficiency is about one-fifth for those two species of cereals.

3rdly. That the produce would be sufficient for the wants of the arrondissement if the harvest of barley and of buckwheat is not compromised; with this observation, that the barley is already injured.

4thly. That the influence of the temperature must be considered as the cause of the diminution and the inferiority of the produce.

5thly. That the atmospheric accidents have been the unusual cold in spring, the heavy and continual rains in May and June, and the excessive heats which succeeded during the month of July; that all these accidents were necessarily injurious, in the first place, to the blossoming, and afterwards to the formation and the development of the grain, whose yield will, consequently, be lighter.

Meanwhile, the French press is calling general attention to the subject. It fears, if not a scarcity of bread by the middle or end of the winter, at least a *dearness* of that article; and it is especially apprehensive of the consequences of such a fear acting upon the popular mind. When we remember the past history of France, the amount of a harvest becomes a matter of vital importance to the country.

Before taking leave of the *Conseil d'Avranches*, I will mention, that "In consideration of the lateness of the cereal harvest this year, of buckwheat particularly, it expresses the wish that the opening of the sporting season may not be fixed before the 20th of September. It petitions *M. le Préfet* to take this expressed wish into consideration."

Englishmen would not like a similar interference, and would be jealous of trusting any single individual, whether *Préfet*, or Lord-Lieutenant of the county, with the power of shifting the 1st of September, and of sparing the partridges till the end of the month. But there can be no doubt that it would be a good thing if some constitutional authority—for instance, the county magistrates assembled in quarter sessions—could exercise a like discretion. In France, the *ouverture de la chasse*, or opening of the shooting-season, takes

place at a different date, in different *arrondissements* and *communes*, according to circumstances. Liberty, in the abstract, is a very good thing; but, if we are to have any legislation on the subject of game, the liberty of killing half-grown birds, and of wading amidst standing, or outlying crops, is a great piece of folly.

Fishing is also locally regulated. An *Ordonnance* published not long since, sets forth, that the taking of fresh-water fish is forbidden in all navigable and floatable rivers and streams, in all canals, brooks, and water-courses whatever throughout the Department of the Seine-Inférieure, at all hours of the day and night, during the time of spawning, under certain penalties. The spawning season is fixed from the 1st of January to the 31st of March inclusive, for trout; from the 1st of March to the 1st of May, for eels; from the 1st of April to the 31st of May, for barbel, bream, chub, pike, roach, perch, carp, gudgeon, and bleak. The taking of sea-fish which ascend the rivers and streams, such as salmon, sturgeon, lamprey, flounder, and mullet, may be practised at all seasons, attending to the regulated size of the flounders and mullets taken; but the fishers must throw back into the river any fresh-water-fish which they may catch along with the sea-fish during the close time. Smelts may be taken only from the 1st of October to the 15th of April. Fishing may be practised an hour before sunrise, and an hour after sunset. It is prohibited during the rest of the night, except at the arches of bridges, at dykes, locks, and sluices, where it may go on by night as well as by day. The fishing for salmon, flounders, mullets, &c., is also excepted from this prohibition, for they may be taken at any hour of the day and night. The shrimp and prawn fishery (by nets) is also restricted, for the sake of sparing the fry of turbot, cod, soles, &c., which are usually taken with them. But, it should be remembered, that a single fish of prey—and all are fishes of prey—a middle-sized cod, or skate, or turbot, will make more havoc among the rising generation of their own nearest relations, than half-a-dozen human shrimp-catchers.

Normandy cider has so well-established a reputation as to be deservedly world-famous. But the Normandy of the old *régime* has, since the First Revolution, been divided into the five departments of Seine, Inferieure, Eure, Calvados, Orne, and Manche. Though cider is abundant in all these, Calvados is pre-eminent, both for quantity and quality, and is the main source of that enormous supply of terrestrial nectar which annually flows from the earth, through the stems of innumerable apple-trees, to assuage the thirst and cheer the hearts of hundreds of thousands of hard-working mortals. The beverage itself derives a name from the department, exactly as Moselle, Champagne, and St. Julien are wines that are designated by the title of their place of growth and vintage. CALVADOS, printed in large letters on the sign-board or shutters of any house of entertainment in Normandy, means to say that *there* a draught of Calvados cider is to be had.

A distinction is made in Normandy, which is hardly known out of it, between the different qualities of cider. The strongest and the best only is honoured with the name of *cidre*; the weaker and inferior—anything in the shape of a second-chop brewing—is styled *boisson*, or drink. Of both immense quantities are consumed, of the latter especially, which, when well-flavoured, as it most frequently is, and from a cool cellar, is even more deliciously refreshing, on a hot summer's day, than the more potent liquor. *Cidre* only is thought worthy of being bottled; *boisson* never, except in large stone ware receptacles for the day's convenience and consumption. *Boisson* is always very cheap; it flows everywhere, almost like water. Cider varies in price, according to its real or fancied merit, and the pains and taste bestowed on the mode of bottling it. The *dearest* I have ever tasted was at an inn at Montevilliers, where this special *bin* was called *Sillery de Normandie*, and leaded down at the cork, and smartly labelled, like Champagne. We were charged a franc, or tenpence, the bottle; and it certainly was excellent. But we are now using some very nearly as good, at six sous, or threepence, for a large stone bottle holding four good tumbler glasses. The most luxurious of these drinks is first-rate *draught* cider out of one of their large *barriques*, or barrels, that is just fresh tapped.

A sentence or two from a Havre paper will illustrate both the great drought of April 1852, and the plentifulness of cider in Normandy:—"The want of water in those localities where there are wells and reservoirs only, and no streams, has come to such a state, that in some houses they make use of *boisson* for domestic purposes. There are many parishes where it is absolutely necessary to fetch water eight *kilometres* (about four miles English), and where, consequently, there is real economy in employing *boisson* to take its place. We are assured that many (religious) processions have already been undertaken, in order to obtain the cessation of this so injurious drought."

Immediately after entering within the boundary of Normandy, the abundance of this popular beverage is perceptible, from the manner in which it is, in Norfolk phrase, *slumped* upon the table at every meal, at every inn. Large wide-mouthed decanters full of the pale yellow fluid, slightly bubbling and sparkling from the cask, and without stoppers, which are never dreamt of, drop hither and thither on the well-covered board, and utterly push the water-bottles aside. It is an effectual, though not altogether a complete expulsion of the weaker by the stronger. Empty the decanter of *boisson*, which stands at your elbow, and, *presto!* behold another filled to the very neck; but you sometimes have to ask two or three times for a glass of water fresh from the well. At a *table d'hôte* breakfast, all the cider you can swallow is included in the charge; I have sometimes thought, that the more you drink of it, the better they like you; but if you take coffee at your morning meal, *that* is considered an extravagance, and is made an extra item in the bill. For the almost universal fashion at the Norman inns, is to eat only two meals a day, and those right good ones, breakfast at ten, and dinner at five o'clock. I have long tried to find the difference between the *dejeuner*, and the dinner, but cannot discover it. At first, a false clue to the secret was given by the occasional absence of soup; but we went further, and fared *better*. A genuine Norman breakfast begins with soup, with oysters, and prawns, perhaps, as a preliminary skirmish to the coming onslaught; then it proceeds legitimately through boiled beef, salad, ragout, cutlets, fish, roast meat, and so on, and concludes with a dignified dessert of fruit, cheese, and sugar biscuits. Everybody drinks *boisson*, cider, and wine; water *may* be had with a little pains-taking. Tea and coffee are no more alluded to than if the company were at one of Lucullus's suppers in the hall of Apollo. It is absurd to apply the terms of "breakfasting and dining," to such a course of regimen. A real Norman never "breakfasts," at least in public; he only eats two dinners a day. And there is little distinction of sex in this matter. If a lady sits down to table, and eats a plate of soup, a slice of beef, a mutton chop, a couple of rolls, a quantity of salad or green haricots, a slice of gruyère, a pear, and a peach, with a tumbler or two of Bourdeaux wine slightly diluted with water,—Will any Englishman call that a "breakfast," at whatever hour of the day the deed may be done? And if the same feats are performed at any subsequent hour, what is that? Dining again. But every country has its own customs; and it must be allowed that the appearance of the Normans generally does full credit to the liberality of their diet. Many of the women are perfect models of the Michael Angelo style of figure; and men six feet high and upwards, bony and muscular, with broad shoulders, large good-humoured features, and the limbs of giants, which do not quite answer to our usual notion of Frenchmen, any ten of whom can be thrashed by any one Englishman. I got considerable credit for observing that the Normans could not be an ordinary people; otherwise they would not have effected the conquest of England; and, on reflection, I cannot confess the remark to be either false or too flattering. At Valogues, particularly, I was struck with several faces which bore a remarkable resemblance to the portraits of the notables of our early history. Fancy might be something, but not everything in the matter. D.

(To be continued.)

DORCHESTER POULTRY SHOW.

THIS Show, on the 24th of November, taken altogether, was a very good one for the first; there were 200 pens of birds, including several pens of extra stock. "The Town

Hall was much too confined a place, and the coops much too small for Cochins; and some of the wire fronts had much too small a mesh, some not big enough to put your finger through; but next year no doubt they will improve. Neither was the arrangement of the pens well managed—some being very low, and others up too high. The judges were Mr. Baily, of London, and Henry Hinxman, Esq., of Durnford, near Salisbury.

The *Spanish* were very indifferent; *Dorkings* good; *Cochins* very good, especially Mr. Steggall's and Mr. Devenish's. The first prize Cochins were the best match ever seen, both in size and colour. They were small, but good-shaped, and looked older than specified. The *Malays* were middling; but some very nice specimens of *Game* fowls were there; and the *Spangled Hamburg*, very few entries, were fair. *Polands*, only two competitors, were very nice, but all had dark feathers, more or less, in their breasts. There were some very beautiful *Bantams*, especially those which gained the first prize, belonging to A. C. Sayers, Esq. *Geese*, good. *Ducks*, a large entry, and some very fine specimens, both Rouen and Aylesbury white. *Turkeys*, very few and middling. Considering the weather, the attendance was very good, and a great many sales took place. Parties were very eager to buy; and to those who are not initiated in the £1000 prohibitory clause, as at Birmingham, could not understand the enormous difference in price of birds of nearly the same apparent value. The attendance before two o'clock, price 2s., was very good; and after that, at 1s., there was quite a crowd, and it was very difficult to get about.

SPANISH.

Cock and two hens.—No first prize. 2nd. Mr. C. Clark, Street.
Cockerel and three pullets.—No award.

DORKING.

Cock and two hens.—1st. Mr. E. Pope, Great Toller. 2nd. Mr. W. Pope, Symondsburly. 3rd. Mr. F. Noyes, Laverstock.
Cockerel and three pullets.—1st. and 2nd. Mr. E. Pope. 3rd. Mr. W. Pope.

SHANGHAE.

Cock and two hens.—1st. Mr. C. D. Saunders, Tarrant Hinton. 2nd. Mr. F. C. Steggall, Weymouth. 3rd. Mr. A. C. Sayers, Ramridge, near Andover.
Cockerel and three pullets.—1st. Mr. W. Symonds, Milborne. 2nd. Mr. J. Crane, jun., Tolpuddle. 3rd. Mr. H. Fookes, Whitechurch.

MALAY.

Cock and two hens.—1st. Mr. C. Clark, Street. 2nd. Mr. H. Williams, Stinsford. 3rd. Mr. A. C. Sayers, Ramridge.
Cockerel and three pullets.—No first prize. 2nd. Mr. W. Manfield, Dorchester.

GAME.

Cock and two hens.—1st. Mr. J. T. Ensor, Dorchester. 2nd and 3rd. Mr. J. Crane, jun., Tolpuddle.
Cockerel and three pullets.—1st. Mr. J. T. Ensor, Dorchester. 2nd. Mr. J. Crane, jun., Tolpuddle.

GOLDEN-SPANGLED HAMBURGH.
(No award).

SILVER-SPANGLED HAMBURGH.

Cock and two hens.—No 1st prize. 2nd. Mr. C. Clark, Street.
Cockerel and three pullets.—1st. Mr. C. Clark.

GOLDEN-PENCILLED HAMBURGH.

Cock and two hens.—1st. Mr. C. Clark, Street.
Cockerel and three pullets.—1st. Mr. C. Clark.

SILVER-PENCILLED HAMBURGH.

Cock and two hens.—No 1st or 2nd. 3rd. Mr. R. Fookes, Milton Abbas.

POLAND.

Cock and two hens.—1st and 2nd. Mr. T. P. Edwards, Lyndhurst Railway Station.
Cockerel and three pullets.—1st. Mr. T. P. Edwards.

BANTAMS.—GOLD OR SILVER LACED.

Cock and two hens.—1st. Mr. J. Goodenough, Godmanstone. 2nd. Mr. J. Crane, jun., Tolpuddle.

BANTAMS.—BLACK, WHITE, &c.

Cock and two hens.—1st. Mr. A. C. Sayers, Ramridge. 2nd. Mr. R. Fookes, Milton Abbas.

GEESE.

Gander and one Goose.—1st. Mr. W. H. Drummond, Troytown. 2nd. Mr. W. Manfield, Dorchester.

DUCKS.

Drake and two Ducks.—1st Prize to Mr. R. Genge, Waterson; Mr. E. Pope, Great Toller; and Mr. T. D. Chard, Tarrant Hinton. 2nd. Mr. W. H. Dunman, Troytown. 3rd. Mr. T. P. Edwards, Lyndhurst Railway Station.

TURKEYS.

Cock and one Hen.—1st and 2nd. Mr. W. H. Manfield, Dorchester.

HITCHIN POULTRY SHOW.

The *Hitchin and Home Counties* first exhibition of domestic poultry took place on the 20th, 22nd, and 23rd instant;

and a first attempt has seldom achieved better success than crowned the efforts of the spirited projectors. Mr. Goodwin, and the gentlemen of the committee, were aided in the arrangement of the details by one of our spirited Birmingham amateurs, and all were, and had reason to be, gratified by the result.

As usual on these occasions, the Shanghaes formed the chief attraction, and numbered nearly one-third of the fowls exhibited; nor did they fail to do their part toward the support of this popularity, for in half-a-bucketful of eggs which were removed from the pens during the exhibition, for the purpose of being destroyed, there were five only which were not laid by Shanghae hens.

Mr. Taylor, of Shepherd's Bush, showed a pen of his pretty *Andalusian fowls*, whose compact, domestic look, and bright slate-coloured plumage, form a decided improvement, in appearance at any rate, on their first cousins, the Spanish, of funereal hue.

JUDGES.—Edward Hewitt, Esq., Eden Cottage, Spark Brook, Birmingham; and Mr. Baily, Mount Street, Grosvenor Square, London.

COCHIN-CHINA. (WHITE.)

Cock and two hens.—1st. John Fairlie, Esq., Cheveley Park, Newmarket. 2nd. Mr. William Lort, Ward End, Birmingham. 3rd. Mr. G. C. Peters, Moseley, Birmingham.

Cock and three pullets.—1st. Mr. G. C. Peters, Moseley, Birmingham. 2nd. Mr. William Lort, Ward End, Birmingham.

COCHIN-CHINA. (COLOURED.)

Cock and two hens.—1st. Mr. H. Gilbert, 17, Upper Philimore Place, Kensington. 2nd. John Fairlie, Esq., Cheveley Park, Newmarket. 3rd. C. Punchard, Esq., Blunt's Hall, Haverhill.

Cock and three pullets.—1st prizes to Mr. H. Gilbert, 17, Upper Philimore Place, Kensington; Mr. G. C. Peters, Moseley, Birmingham; Mr. W. Lort, Ward End, Birmingham; and Mr. R. Steward, South Town, Yarmouth. 2nd. W. T. Squire, Esq., Barton Place, Mildenhall. 3rd. C. Punchard, Esq., Blunt's Hall, Haverhill, Suffolk.

DORKING. (WHITE.)

Cock and two hens.—2nd. Mr. J. Jennens, Moseley, Birmingham.
Cock and three pullets.—1st. Mr. H. Forster, Markyate-street, Herts. 2nd. Miss Mary Lane, Maidencroft, Hitchin.

DORKING. (COLOURED.)

Cock and two hens.—1st. Mr. Oliver Steed, Baldock. 2nd prizes to Mr. F. Thursby, Abingdon, Northamptonshire; Mr. H. Forster, Markyate-street, Herts; and Mr. G. C. Adkins, Edgbaston. 3rd. Mr. Joseph Lucas, Hitchin.

Cock and three pullets.—1st. Mr. T. Nice, Great Bradley Hall, Suffolk. 2nd. Rev. J. Boys, Biddenden, Kent. 3rd. Mr. W. Harrison, Bagworth Park, Leicestershire.

SPANISH.

Cock and two hens.—1st. Hon. Mrs. Astley, Swanton House, Thetford. 2nd. Mr. John Taylor, jun., Cressey House, Shepherd's Bush, London. 3rd. Mr. James Barber, Great Yarmouth.

Cock and three pullets.—Prizes withheld.

GAME FOWLS. (WHITE.)

Cock and two hens.—1st. H. Thurnall, Esq., Royston, Hertfordshire. 2nd. Mrs. Hoggett, Norton, near Baldock.

Cock and three pullets.—1st. Mr. W. Groom, Holt, Norfolk.

GAME. (COLOURED.)

Cock and two hens.—1st. Henry Thurnall, Esq., Royston. 2nd. Mr. W. Groom, Holt, Norfolk. Two 3rd prizes. Henry Thurnall, Esq., Royston.

GAME. (COLOURED.)

Cock and three pullets, chickens of 1852.—Two 1st prizes. Henry Thurnall, Esq., Royston. 2nd. Mr. A. Cannell, Cringleford, Norfolk.

GOLDEN-PENCILLED HAMBURGH.

Cock and two hens.—2nd. Mr. T. Church, Acle, Norfolk.
Cock and three pullets.—1st. Mr. T. Barber, Acle, Norfolk.

GOLDEN-SPANGLED HAMBURGH.

Cock and two hens.—1st. Mr. G. C. Adkins, Edgbaston, Birmingham. 3rd. Mr. T. Cane, Baldock.
Cock and three pullets.—No entry.

SILVER-PENCILLED HAMBURGH.

Cock and two hens.—1st. The Hon. Mrs. Astley, Swanton House, Thetford. 2nd. Mr. J. Dutton, Bury St. Edmunds.

Cock and three pullets.—1st prizes to Mr. Charles Thurnall, Whittlesford, near Cambridge; and Francis L'Estrange Astley, Esq., Burgh Hall, Thetford. 2nd. Rev. Justice Chapman, Clareborough Vicarage, East Retford. 3rd. Mr. James Monsey, St. Miles, Thorne Lane, Norwich.

SILVER-SPANGLED HAMBURGH.

Cock and two hens.—1st. Mr. Joseph Jennens, Moseley, Birmingham. 3rd. W. J. Vivian, Esq., Singleton, Glamorganshire.
Cock and three pullets.—No entry.

MALAY.

Cock and two hens.—3rd prizes to Mr. M. Ridgway, Dewsbury, Yorkshire; and Mr. W. Harrison, Bagworth Park, Leicestershire. Class not Meritorious.

Cock and three pullets.—Prizes withheld.

POLAND FOWL. (GOLDEN.)

Cock and two hens.—1st. W. J. Vivian, Esq., Singleton, Glamorganshire. 2nd. Mr. C. Stephenson, 2, Loudoun Place, Brixton, Surrey.
Cock and three pullets.—2nd. Mr. C. Stephenson, 2, Loudoun Place, Brixton, Surrey.

POLAND FOWL. (SILVER.)

Cock and two hens.—1st. W. J. Vivian, Esq., Singleton, Glamorgan-shire.

Cock and three pullets.—2nd. Mr. C. Stephenson, 2 Loudoun-place, Brixton, Surrey. 3rd. Mr. Youell, Yarmouth.

POLAND FOWL. (OF ANY OTHER COLOUR OR VARIETY.)

Cock and two hens.—1st. Mr. G. C. Adkins, Edgbaston, Birmingham.

2nd. W. J. Vivian, Esq., Singleton, Glamorgan-shire.

Cock and three pullets.—No entry.

MIXED BREED.

3rd. Mr. Hainworth, Hitchen, and Mr. Bennell, Hitchen.

(The Judges disapprove of this class.)

FOWLS. (DISTINCT VARIETY, NOT NAMED IN THE ABOVE CLASSES.)

1st. Mr. John Taylor, jun., Cressey House, Shepherd's Bush, London.

2nd. Mr. E. Hughes, Yarmouth. 3rd. W. J. Vivian, Esq., Singleton, Glamorgan-shire.

BANTAMS. (GOLD LACED.)

Cock and two hens.—1st. Mrs. Elizabeth Roper, Croxton, Thetford, Norfolk. 2nd. Mr. U. Spary, Markyate-street, Herts.

BANTAMS. (SILVER.)

Cock and two hens.—1st. Mr. H. J. Jones, Bedford. 2nd. John Fairlie, Esq., Chevely Park, Newmarket.

BANTAMS. (WHITE.)

Cock and two hens.—1st. Mr. M. Leno, jun., Hemel Hempstead.

BANTAMS. (ANY OTHER COLOUR OR VARIETY.)

Cock and two hens.—1st. Mr. James Monsey, St. Miles, Thorne Lane, Norwich. 2nd. Mr. Wheeler, Hexton House, Herts. 3rd. Mr. M. Ridgway, Dewsbury, Yorkshire.

GUINEA FOWL.

Cock and two hens.—Mr. Joseph Whiting, Hitchin.

TURKEYS.

Cock and two hens.—1st. John Fairlie, Esq., Chevely Park, Newmarket.

2nd. Mr. W. Harrison, Bagworth Park, Leicestershire; Mr. A. Cannel, Cringleford, Norfolk; and Mr. G. Roberts, Kingswalden, Herts.

3rd. Mr. Charles Thurnall, Whittlesford, near Cambridge; and Mr. John Steed, Baldock.

GEESE.

Gander and two geese.—1st. Mr. J. Taylor, jun., Cressey House, Shepherd's Bush, London.

DUCKS. (WHITE AYLESBURY.)

Drake and two ducks.—1st. Mr. Arch, Clifton, Beds. 2nd. Mr. C. Thurnall, Whittlesford, near Cambridge. 3rd. Mr. Robert Tingey, Henlow Beds.

DUCKS. (COLOURED VARIETIES.)

Drake and two ducks.—1st. Mr. Youell, Yarmouth. 2nd. C. Punchard, Esq., Blunt's Hall, Haverhill, Suffolk.

MUSCOVY.

Drake and two ducks.—1st. Mr. John Steed, Baldock, Herts.

PIGEONS.—Twelve prizes were awarded to Mr. G. C. Adkins, Edgbaston, Birmingham; and Mr. Beazor, Yarmouth; Mr. O. Steed, Baldock; and Mr. J. Playford, Yarmouth, had each a prize.

TO CORRESPONDENTS.

BEE-KEEPING.—“The three questions asked me by your correspondent, B. B., at page 210, I will answer in this communication. First, I must ask B. B. to remember that the word ‘enormous’ was not applied by me to swarms, but to one swarm; and B. B. must also understand that both that term, as well as the expression ‘amazing quantity,’ &c., were only incidentally used in acquainting you, at your request, with my experience of the ‘Country Curate’s’ system, and not with a view to publication. Before alluding to the subject of B. B.’s questions, I have to inform you that five hives were tried by me on that plan, though I said nothing of the fifth in my last to you, and for this reason;—It was my intention greatly to alter this hive (though not destroy it), which would, of course, prevent it being a fair subject for experiment. When I did alter it I found it very full of bees, and containing nineteen pounds of honey—in fact, full; but the plan of the hive (a wood and glass toy affair) is miserable, as you may well imagine when that is all it will contain. Three of the four others I consider the best I have in all respects, but regret now to report badly of the remaining one. This failure was a swarm of June 24th, and an earlier one than one of the last three alluded to. The hive that threw off two swarms in one swarmed June 20th, and is as strong as any I have, weighing now 21 lbs. contents, and full of very savage bees, which I like. On looking over my apiary on Wednesday last, for a good hive, to give a friend in exchange for a Cochinchina cock, I pitched on the failure, weighed it, found it contained at least 21 lbs. of honey, and thought all ‘ouleur de rose.’ My gardener (a great hand at bees) remarked, ‘They seem very quiet, Sir;’ and so they might, for on turning it up there appeared a very very few in it. To-day I smoked it down with *Racodium cellare*, and it did contain a queen, though her majesty was small and poor looking; and the bees, about 3 lb., filled a dinner tumbler of the ordinary size. I have just most carefully weighed the honey, and find it 22½ lbs.; so my Wednesday’s calculation was 1½ lbs. under. Of these five hives the wood and glass toy hive was not shut up at all; the rest only until the evening of their swarming days. Three were moved to new stands, one hundred yards from the old place; and two to new stands, forty yards from the old place. The failure (?) was moved one hundred yards, so was that which threw off the two swarms in one; the good old hive forty yards. While I was a month at Scarborough, my heaviest straw hive went wrong, and was of course emptied by the other bees; and whether the uproar injured the ‘failure,’ which stood next it, you must judge—that is the opinion of my gardener. Question 1.—I use three-sized hives of straw; one weighs, empty, 3 lbs., another 7 lbs., the third 9 lbs. All three have straw tops, with 3¼-inch holes in them. The first has a perfectly flat top, and measures (inside measure) 12½ in. by 9½ in. The second is

shaped like the old bell-hive, but a portion of the top flat, and measures 14½ in. by 10 in. deep. The third, which I alluded to as “a very large hive,” measures 14½ in. by 13½ in. deep. The shape of this last is, I know, against all rule; but they do very well with us. Question 2nd.—I never did weigh a swarm, though I have seen and hived a great many, and know a large one, when I see it, even on a hot day. Question 3rd.—I broke up, August 1st, three hives, each weighing (contents of course—honey and comb) as follows:—First, 36 lbs.; second, 32 lbs.; third, 30 lbs. Same day I broke up two old hives of wood, to convert into Taylor’s—first, 34 lbs.; second, 27 lbs. You will be interested in knowing that the bees driven out of two of the first three mentioned were joined and put into an empty hive, and sent the same day to the moors, with the cap in its top full of honey, which the good old hive made, to start them with. This hive returned containing 18 lbs. of moor honey, and the cap as full as it went. At the same time I sent to the moors two late swarms; one returned containing 33 lbs., the other 35 lbs. The above is the ‘amazing quantity,’ with the addition of 22½ lbs. got from the failure (?) an hour ago. My plan of dealing with Taylor’s hives is exactly similar to Investigator’s plan of dealing with Golding’s; and our success seems pretty much the same, except that, perhaps, his top would not hold more than 28 lbs., whereas mine hold about 33 lbs. full. We all here think that if I had had twelve Taylor’s, instead of three, this season, every top would have been full. 12 times 33=396, supposing each hive, of course, to be reasonably strong to start with. If I live to another season my plan will be, seven ‘Taylor’s,’ five ‘Country Curate’s.’ ‘Investigator’ says July (all July) was very productive; so I found it. I cannot account for the wonderful quantity of honey gathered so late this last season; I never before found it so. We had no rain during the month of July in the day-time, and fearful heat, but splendid showers at night. Pray excuse the length of this, and believe me yours truly. P. S. October 27.—This should have been posted a fortnight ago. My bee-keeping, I admit, is neither for pecuniary profit nor scientific enquiry. I am tempted to add, that if they shut up their old hives for such long periods, it is not to be wondered at that when they are let out, and fly back to their old stands, they are not recognised, if scent has anything to do with it.—C. R. R.”

CYCLAMEN LEAVES ROTTING-OFF (Flora).—This has probably received rather too much wet, out-of-doors, but do not despair; take away every leaf carefully, that shows the least trace of decay. Put the plant in any window where you can give it air in this mild weather. Do not give much water until the weather changes, or the plant seems to want it, by the first symptoms of drooping; prevent frost from hurting it; top-dress with a little rich, light soil; strew some powdered charcoal over the top of the tuber, whence you remove the fading leaves, and unless there is something radically wrong, such as having been shaded when the leaves were growing, we think you will yet be rewarded with bloom.

GLOXINIA (P.).—You ask how to shade in a light forcing-house, glass all round. We do not think shading will be required now. When the sun gets strong it will. Any usual mode will do. We generally place them in the front of such a house, and paint the glass a little higher than their tops, with hot, double size, and we find this effectually saves the bloom.

VIOLA ARBOREA (Subscribers).—See an article to-day by Mr. Fish.

CLIMBERS (An Old Subscriber).—In addition to those you have for stove, *Passiflora princeps*, *Passiflora kermesina*, *Allamanda cathartica*, *Hoya carnosa*. We presume there is plenty of light. For the middle house, *Mandevilla suaveolens*, *Kennedyia Marryattæ*, *Tacsonia pinnatifida*, *Tecoma jasminoides*, or *Cherere*; for greenhouse, *Dolichos lignosus*, *Jasminum gracile*, *Hardenbergia macrophylla*. Lists of climbers for different purposes have been given lately.

FLOWER-GARDEN (Turquoise).—Your planting is perfect, on the principle of contrasts; we cannot alter a leaf, unless it were 15 (*Unique Geranium*) to *Saponaria calabrica*, for this reason, that young plants of *Unique* do not flower freely, and that old ones will make the bed too high for 16 and 17, without constant attendance to pegging and training. Again, 15 is your match for 20, and it will get higher than 20; if you change 15 for 20, perhaps it will suit better than in *Saponaria*. Then, 20, 21, and 22, would be higher than their opposites, 15, 16, and 17, and that is, no doubt, what you intended. You are certainly not “A Novice.” There is not one out of ten, of old practicals, who could do it half so well. The shapes of 10, 11, 12, and 13, are very unusual, but we shall engrave the whole some day or other.

INDIAN SEEDS (W. C.).—One-hundred-and-forty-five Indian seeds, correctly named, 120 of them are the very pick of the Indian Flora, and the rest not at all so common as we often see from India, and great judgment exercised in the selection, but without a particle of practical knowledge of what we want, and what we can manage in England. We question if there is a nurseryman, or botanic gardener in the three kingdoms, who would give the value of the paper in which they are packed, for all the seeds. If you imagine a line drawn across our Indian territories, from Bombay to Sylhet, you may lay it down as an axiom, that there are not ten kinds of seeds on the south side of that line that are worth the carriage from India; and not twenty seeds from the first fifty or sixty miles to the north of that line.

NOISSETTE LAMARQUE (Some One).—You did wrong by treating this Rose like a Banksian Rose, and so kept it from flowering in the autumn; you cut in the small wood, and cut out the strong shoots. Do exactly the contrary, and you will be rewarded with autumn flowers; but if it comes too strong after the first flowering, you had better give a slight root-pruning, say early in June.

BULBS AND BEDS (An Old Subscriber).—In the first place, are you willing to lay out £20 or £25 on bulbs for your seventeen beds, if that would plant them, which we much doubt? Be content with about 500 mixed *Hyacinths*, 600 mixed *Early Tulips*, 1000 mixed *Narcissus*, 5000 mixed *Crocus*, 100 double *Tulips*, 500 *Spanish Iris*, 500 *English Iris*, in mixtures, 600 or 700 double, single, and star-flowered *Anemones*, about 300 *Turban Ranunculus* in three colours, 50 *Fritillarias*, 100 *Crown Imperials* in four colours, 50 *Martagon Lilies* in four colours, 500 *Colchicum autumnalis*, 50 *Dogtooth Violets* in two colours, 50 *Feathered Hyacinths*, 50 *Grape Hyacinths*, 50 *Musk Hyacinths*, 1000 *Winter Aco-*

nites, 1000 double and single *Snowdrops*, with as many florist's bulbs as your own fancy tells you. We would not plant a quarter of your space with bulbs. Your garden will look more like a nursery in Holland than anything else; too much of a good thing is as bad as too little, and yet the above will only make a scanty clothing for your space.

GLADIOLI (Regular Subscriber).—The heights are relative, but what the proportions are on your soil we cannot say. The highest is 1, *Gandavensis*, orange-scarlet; 2, *Ramosus*, white and red; the rest are about the same height, or, say on an average, a yard high, and the colour various shades of red and orange. *Psittacinus*, *Gandavensis*, and *Floribundus*, may be planted any time between this and April. The right name of *Floribundus* is *Oppositiflorus*; and if you have it true, it is all but white. The rest of them should be planted now. The time of flowering will be governed by your locality, and the time of planting; for instance, if you plant *Psittacinus* now, it will come in flower next June; plant again in the beginning of February to bloom in July; plant in March for August bloom, and in April for September and October bloom.

TROPEOLUM TUBEROSUM.—Wareham says—"I dug up my *Tropæolum tuberosum* a day or two ago, the result was—Twenty-one tubers, larger than the original, for which I gave 1s.; twenty-two about the same size; twenty-four somewhat smaller; and something like sixty very small. I cooked a few, and they were very nice, resembling Asparagus somewhat in flavour. The small I have pickled. They are not amiss raw, as a salad. A paper in *Chambers' Edinburgh Journal* mentions that they produce fifteen to eighteen tubers; if that is the average, I must consider mine as a good crop; and I think I should have had more had I earthed it up, as there were many immature tubers outside the ground. It was manured with wood ashes and burnt sticks, half-charred. Though it cannot be expected to supply the place of the Potato, yet I see no reason why it should not be cultivated as an esculent. The tubers keep well, and, as an occasional dish, would, I think, be found useful. Can you suggest a way to make it flower well?" Your crop was very good, a little above the average on good land. Tastes differ so much in these things, that we do not like to say much either way. We have tasted them, and all the Oxalises that have been recommended, and we still prefer the worst potato to the best of them.

ROSES (Ibid).—They will do perfectly well where you say, and they require little or no sun in winter; same with Pinks and Carnations.

NAME OF HARDY SHRUB (C. G.).—Yours is the Sea-Buckthorn, or Sallowthorn (*Hippophae rhamnoides*); one of those few bushes that will grow well in sea-sand, to the edge of the tide.

FUCHSIA-BED (M. Fermanagh).—Your compost is very good for a Fuchsia-bed; indeed, too good to be passed—One-part garden mould; one-part turf, ashes, and a little sand; and two-parts turf. Fuchsias will grow well like willows in such a soil. Make it full two feet deep for them. But do not think of planting climbers in the centre of such a beautiful bed; nor a *Corymbiflora Fuchsia* either, which, instead of being "too delicate," is so ravenous, that it would eat up all the others before the end of the season. For a row in the centre, *Riccartonii* or *Gracilis* are the cheapest, and as good as any if you transplant them every other spring, so that they do not encroach on the new sorts all round. Look at the list we gave last July, before you decide on what kinds to plant. Your *Cleopatra Fuchsia* will grow too strong for *Dr. Jephson*, so you must keep them well apart, with others between.

BEES IN TAYLOR'S HIVE (A Subscriber).—Our correspondent says:—"I have a stock of bees in Taylor's Boxes, as described in his 'Bee-keeper's Manual,' third edition, page 17. The stock-box they have been in three years, the combs are getting very black, so that I should be very glad to change them into another, and I think there is now a chance of so doing, if I knew how to proceed; they being very strong the summer before last, I put a cap on, *fast*, so that I cannot now take it off. I have been following the side-box system, as described in the above work, page 29, but have not succeeded very well, as they swarm most seasons, and scarcely ever fill the side-box; last summer they threw off a strong swarm in June, and were very full afterwards. I put a side-box too, they worked very well into it, but did not above half fill it, and by what I could see through the glass, I thought there was little or no honey in it, so I thought I would let it remain till the bees left it, and were in the stock-hive, and then take it away, and put the stock-hive in its place. I have tried several times, but always found a great many bees in it, so I thought I would let it remain till the weather became cold. Last night being very cold, the thermometer out down to thirty-two, with cold wind, and the Staffordshire hills covered with snow, but as soon as I stirred the box they were all on the move, as usual. I tilted the box up two inches on one side, hoping they would go into the other at six o'clock; I then let it remain till ten o'clock, but then found them all, as usual, in the side-box, and very irascible; in fact, one flew out and stung me, whilst lowering the box down on to the floor-board. This morning I find them there as usual, and on examining the stock-box, found but three or four bees in it, but very heavy indeed with honey, full quite three-parts down. I have put it in its place again, but should be very glad if I could take it away, so that the bees may have the box with new combs; but how will they succeed, the box being but half-full of combs? There is plenty of honey in the stock-box, and I should be glad to know how to give it to them in the best way. I always feed at the top, with tins, as described in the above work, page 65. Would it be better to put the honey in the comb in the tins, and feed them in that way; and would they increase the combs at this season of the year? or would it be better to put the box the bees are in, on the top of the stock-box, and let them help themselves? but I fear in that way they would again take possession of the stock-box, with the old combs, which I do not want them to do." You may safely take the stock-box away, but cut seven or eight pounds of honey-comb out of it, and place it under a cap or bell-glass, upon the top of the box the bees are in, and when they have emptied the combs of honey, give them another supply.

SHANGHAE OR COCHIN-CHINA FOWLS (Brixton).—These are one and the same, and we have abided by our determination to call them *Shanghae* only. We cannot make our correspondents always do so. The variety is not known in Cochin, and they are found only about Shanghae, and other northern districts of China. "China fowls," as you suggest, would be a correct name, but we think *Shanghae* is accepted generally.

The following, from a correspondent in Gloucestershire, quite agrees with what we have ascertained from a traveller recently from China, and which we shall soon publish in another form. "You would oblige by informing me, if you can, why the 'Poultry World,' in speaking of China fowls, use indiscriminately, as they do, or, in fact, why they use at all, the prefix 'Cochin,' and do not call them simply 'China fowls?' I have endeavoured, but in vain, to ascertain the origin of the name 'Cochin-China,' as applied to fowls, and cannot learn that there is, but, on the contrary, I believe, from all I have learned, there is not, any breed peculiar to and to be found in that particular part of China, or bearing its name. I have kept China fowls for nearly four years, and possess birds bred from the largest sort, and some of the earliest (if not the first, except the Queen's, presented to Her Majesty by the Emperor of China) introduced into England; those birds, however, came from a far more northerly province, viz., that of Peang-nan, in China Proper, to which place, also, I know that the best birds in this country, that is, those that have taken prizes during the past and current year, are indebted in part, if not wholly, for their parentage. The synonyme of *Shanghae*, which has now become generally current, was given to the race to which mine belong merely because they were shipped from the Port of that name, and as a distinction from the smaller class of birds which at the earliest English Exhibitions were described and acknowledged by the Judges as *Cochin-Chinas*, between which and mine there is a great difference, as there is also between those originally and those now received as *Cochins*. In one of your recent numbers, an article appeared stating as a necessary characteristic of pure *Cochin-China* fowls that they must have no tail feathers, I should be glad to know upon what authority it is so stated. I maintain that pure bred China birds (cocks), of the finest sorts, come from what part of that country they may, have, or ought to have, perfect tail feathers, but of a dwarfish description; they should, I am told, be fourteen in number; and if any of these are wanting, the attention of the judges at exhibitions should be directed to ascertain whether such feathers have been lost accidentally or plucked intentionally to meet the erroneous and absurd fashion of the day, which appears to be 'that the best China fowls must be a buff colour and tail-less.'—T. A." We do not remember anywhere its being stated in these pages that *Shanghae* fowls should be without tails altogether, but we are quite sure that cocks of the pure breed have no sickle feathers in their tails.

POTATO-ONION (F. Withers).—Plant offsets in early spring, about the beginning of March, in rows eight inches apart, and the point of each offset just above the surface. The soil as for other onions. They have completed their growth by September, and may then be taken up to plant again at the end of October, or to be kept until the following spring. Do not earth them up, nor give any cultivation except an occasional earth-stirring.

PARLOUR AQUARIUM.—Clericus would be glad to know where he can purchase one of these. He also requires some seed of *Polygonum vacciniifolium*.

EXCHANGE OF DUCKS, &c. (Vicar).—We have given notice that we cannot insert such notices in future. We are not merely liable to advertisement duty, but give offence to advertisers.

WHEAT DIBBLING MACHINE.—J. R. N. wishes to know which is the best for making the holes and delivering the seed at the same time.

BEES (H. Edwards).—Leave the comb in the hive, tie a covering over the mouth, hang it in a dry place, and put a swarm into it next year.

DISEASED GRAPES (A Subscriber, Guernsey).—The berries of your Muscats were affected with what is technically called "the spot." The following is extracted from *The Cottage Gardeners' Dictionary*:—"It is a gangrene, probably occasioned by an irregularity in the supply of moisture and vicissitudes of temperature, but especially if one of the extremes is much below the degree of heat most favourable to the healthy growth of the plant. Muscats are particularly liable to this disease." Muscats require a higher temperature than most other grapes, and that of your greenhouse was probably much too low during our recent ungenial weather. The large *Haricot Bean* you enclosed, and which you state is commonly cultivated in the south of France, would be advantageously grown by our cottagers if hardy enough for our climate; its green pods and dried seeds being equally excellent for boiling. It is probably the *Lima* variety, and if so, requires the plants to be forwarded in a hotbed.

WORM-CASTS ON LAWN (Henricus).—These cannot be entirely prevented. Frequent waterings with lime water keep the worms from coming near the surface.

SHANGHAE COCKEREL (A new Subscriber).—Send your address, and state what aged bird you require. The other information you seek will appear in due time.

PUMICE STONE (Pteris, Dublin).—This will do very well for a small fernery.

TROPEOLUM TRICOLORUM (G. P. Willand).—We cannot give you the name of your plant by the two small leaves sent. The *Tropæolum tricolorum* that has put up four inches, and now died down again, we should say has been kept too wet, and most likely its roots have decayed too; whether or not, stop watering until you see if it will put out again, which probably it will not do for several months. September is about the time this plant begins to shoot out, at which time it should be potted. Until growth reappears the pot and tuber may be placed upon a dry shelf.

NAMES OF PLANTS (Troublesome).—The leaf you enclosed is of the *Calla Aethiopia*, mentioned at page 113 of our sixth volume. (J. R.).—The crimson flower is *Siphocampylus Surinamensis*, var. *rubra*. The orchid bud was crushed. (Rev. M. E.).—Yours is *Veronica speciosa*; even in Ireland we think it will not do under a warm wall without protection. (H. B.).—No. 1. *Ruscus racemosus*, or *Alexandrian Laurel*. No. 2. *Gazania uniflora*, a greenhouse undershrub. No. 3 is a *Phlox*, but we cannot determine which.

WEEKLY CALENDAR.

M D	W D	DECEMBER 9—15, 1852.	WEATHER NEAR LONDON IN 1851.				Sun Rises.	Sun Sets.	Moon R. & S.	Moon's Age.	Clock aft. Sun.	Day of Year.	
			Barometer.	Thermo.	Wind.	Rain in In.							
9	Th	Red-throated Diver comes.	30.189	— 30.091	54—52	S.W.	—	56 a. 7	49 a. 3	5 25	28	7 14	344
10	F	Wild Swan comes.	30.057	— 29.981	53—33	S.	—	58	49	6 52	29	6 46	345
11	S	Grosbeak seen.	30.521	— 30.366	51—27	W.	—	59	49	sets.	30	6 18	346
12	SUN	3 SUNDAY IN ADVENT.	30.516	— 30.442	38—30	N.W.	—	VIII	49	5 a 8	1	5 50	347
13	M	Lucy.	30.404	— 30.389	44—37	E.	—	0	49	6 15	2	5 22	348
14	Tu	Stinking Hellebore flowers.	30.472	— 30.416	41—36	E.	—	1	49	7 27	3	4 53	349
15	W	EMBER WEEK.	30.437	— 30.387	40—36	S.	01	2	49	8 42	4	4 23	350

METEOROLOGY OF THE WEEK.—At Chiswick, from observations during the last twenty-five years, the average highest and lowest temperatures of these days are 46.2° and 34.1° respectively. The greatest heat, 61°, occurred on the 13th in 1842; and the lowest cold, 11°, on the 13th in 1846. During the period 106 days were fine, and on 69 rain fell.

WINGED TOBACCO PLANT.

(*Nicotiana alata*.)



THIS is a tender annual, and a native of South Brazil. It belongs to the Natural Order of Nightshades (*Solanaceæ*), and to Pentandria Monogynia of the Linnæan system. Like other tender annuals of the same family, the seeds require to be sown early in spring, on a gentle hotbed, and the seedlings, when they have three leaves, to be pricked out into small pots, and kept under the same frame, and to be moved to their blooming place after re-potting in May. We extract the following from *Paxton's Flower Garden* :—

“We translate literally the account given of this plant by Link and Otto. ‘The stem is from four to five feet in height, branching, with distant, glandular hairs. The leaves are from three to four or more inches long, and from one to two inches broad; the upper ones are smaller; they are all decurrent and form narrow wings on the stem, obtuse, and with a small callous point, but a little repand at the edges, and toothed, the teeth having also little callous points, on both sides rough with small somewhat closely pressed hairs, and at the edges furnished with distant and glandular hairs.

The flowers are placed rather far apart from each other on a raceme; the lower pedicels are one inch long, the upper ones are shorter. The rough calyx is not quite an inch in length, tubular; its teeth are long and very narrow. The flowers are white, and sweet-scented; the tube from two to three inches long, a little expanding at the top; the teeth of the limb, eight lines in length, are oval, somewhat expanded, obtuse. Stamens as long as the tube. Style somewhat longer. Capsules oblong. The seeds of this plant were sent by M. Sello, in 1827, from Brazil. They should be sown in the spring in pots, and the seedlings should be planted out in the open ground when the frosts are gone. The plant is hardy, and may be kept in winter in a temperature of from 38° to 43° Fahr, and as such plants as are strongest flower best and produce most seeds, they should be so treated. The soil should be light, but rich, and mixed with sand. The large, white, odoriferous flowers, forming nice-looking tufts, render the plant suitable for bedding-out. The flowers close in the day-time and hang down, but open at night. If the weather is cloudy they open as early as five, P.M., but if clear, not before six-and-a-half, P.M.; in like manner they shut in the morning at six if the weather be clear, but not before seven if it be overcast.’

“Such is the account given by Link and Otto, of a plant which we think is beyond all doubt what Sir Henry Willock found cultivated in Persia, and sent to England as the source of Shiraz Tobacco; in consequence of which it was called *N. persica* by one of us, and, according to M. Walpers, *N. decurrens*, by Bishop Agardh. We must, however, observe that the Persian plant was not observed to be a perennial; nor do the leaves appear to have been so distinctly decurrent as is represented in the accompanying figure: but the specimens which have been preserved show that the leaves were somewhat decurrent, even near the summit of the flowering-stem. This identification of plants supposed to be distinct, leads to the inquiry of how a South Brazilian plant came to be cultivated in Persia as Tobacco? and also whether any Brazilian Tobacco is manufactured from it? We trust that some one will be able to answer these questions, as well as many others connected with the history of commercial Tobacco; as, for instance, is any Havannah Tobacco prepared from *N. amplexicaulis*, as George Don reported? Is the white-flowered Guatemala Tobacco a species distinct from the Red Virginian, *N. Tabacum*? Are the red-flowered Tobaccos all varieties of *N. Tabacum*? or do they belong to different species, as some pretend? What yields the pitchy Tobacco of Latakia; or the mild Tobacco of Syria? The Djebelé seems to belong to *N. Tabacum*. Is it true that *N. paniculata* is cultivated in the East? How came *N. rustica* to be grown in Egypt and Tunis, where it produces the fragrant but strong Tombaki Tobacco, which was shown at the Great Exhibition of all Nations? Of what country is *N. rustica* certainly a native? All these are interesting questions, to not one of which we believe can a satisfactory answer be found in books. *N. alata* is lost in English gardens, but might perhaps be recovered from Berlin.”

It is a paradoxical but explicable Kentish proverb, that “Tenterden church steeple was the origin of the Goodwin Sands;” and we have heard of a shipwreck being shewn satisfactorily to have been caused by the vessel

having sailed on a Friday; but out of five letters, all accusing *Guano* of being the cause of the Potato murrain, we cannot trace even the pretence of a reason, much less of evidence, on which our five correspondents

round their opinion. One of them, indeed, ventures to say, that "it was never intended that such a mass of excrementitious matter should be brought into this country;" and the inference intended thence to be drawn is that the Potato murrain is a judgment upon us for having done so! We must be excused for characterising such an observation as so absurd, that we think the writer, when he remembers that the disease is in a hundred countries where the use of Guano is unknown, will laugh at his own hasty illogical conclusion.

We have no intention to re-enter, at present, upon the subject of the Potato disease, but we have mentioned the subject of these letters that it may indicate why we think it necessary to explain the cause of Guano being so powerful a fertiliser.

It is a fact, which we pointed out in the "Gardener's Magazine" (vol iv. 81), about twenty-five years since, that manures are powerful in proportion to the quantity of ammonia which they contain. Night soil, we then observed, one of the most beneficial of manures, surpasses all others in the abundance of its ammoniacal constituents in the proportion of three to one; and the nearer any animal approaches to man in the nature of its food, the more fertilizing is the manure which it affords. We added our belief that such power of promoting the vigour of plants arises from the stimulating qualities of the ammonia those manures contain, adding, that we had no doubt that a languishing plant, such as orange-trees, as they usually arrive here from Italy, might be aided in recovering by having their stem and branches steeped in a tepid weak solution of carbonate of ammonia, and by suspending an uncorked phial, containing some of the same solution, among its branches when planted. These opinions are strongly confirmed by the recent experiments of M. Ville, published in the "Comptes Rendus."

When we wrote as above, the use of *Guano* as a manure was unknown among our cultivators of the soil; and it affords another powerful testimony to the truth of our opinion, that manures are powerful in proportion to their richness in ammonia. Professor Way has analysed the Guano brought from various localities, and it is certain that in the following list the specimens are superior as manures, exactly in the proportion they excel each other in ammonia.

Peruvian	17.41 per cent.
Icaboë	7.30 "
Patagonian	2.54 "
Saldanha Bay	1.62 "

So powerful are the effects of the ammonia, that about four hundred weight of Peruvian is a quantity quite sufficient for manuring an acre, and of the others, quantities just proportioned to their ammoniacal constituent. This indicates, unmistakably, the importance to the cultivator of obtaining genuine Guano, and he cannot feel confidence that he will obtain such security, unless he purchases from long-established dealers, who have a business to lose if it is proved that they have deceived their customers.

The increasing demand shows that the value of Guano is confirmed by every year's experience; and we hail the fact as a proof that British cultivators, true to our national character, meet increased difficulties by increased efforts to rise superior over them. The quantities imported in the last five years are as follows (*Farmers' Almanac for 1853, p. 21*):—

	1847	1848	1849	1850	1851
Tons...	82,392	71,414	83,430	116,925	243,016

In Guano the allotment-gardener and the small market-gardener have a powerful friend. Want of capital, and of the means of keeping much animal stock, renders a deficiency of manure their chief difficulty, and Guano releases them from it. We have now seen it employed almost for every important garden crop; and we can testify that it helps them to as excellent a growth as would be obtained by applying twenty times their weight of any farm-yard dung. All the Cabbageworts, Spinach, Celery, Asparagus, Strawberries, Roses, and many other garden plants, we have seen grown without any other manure being added, and we can testify that never was a finer produce obtained, even with a lavish expenditure of the gardener's usual compost. Let all gardeners bear this in mind, and whenever inconvenienced by a deficiency of manure, let them remember that they can purchase the best Peruvian Guano for ten shillings per hundred weight.

COVENT GARDEN.

ERE this, our readers will have had time to consider the proposition we made as to the economical plantations of fruit-trees; and taking it for granted that, with some of them at least, it has met with some degree of favour, we continue the subject.

We have already given a list of those varieties of Apples which we would recommend for dessert use, and which are likely to be most remunerative when taken to market. This week we shall devote our attention to those adapted for culinary purposes; and, carrying out the same plan as that on which we set out, by taking them in their order of maturity, we shall now commence with—

1. *Manks Codlin*.—One of the earliest, best, and most abundant-bearing culinary Apples we have. We have chosen this variety in preference to some of the other early Codlins, because the tree is of a very hardy constitution, succeeds well in exposed situations, and is not very nice as regards soil. This being of a small habit of growth, it would be well to graft it standard high on some other variety of vigorous growth, and which would make a stronger stem than the Manks Codlin would if trained up of itself.

2. *Early Julien*.—To many the name of this Apple will be new, for it is not so well-known as it ought to be, and consequently not so extensively cultivated. It is, nevertheless, a variety of some standing. In the appearance of the fruit it has some resemblance to the *Hawthornden*, but is as superior to that variety as the

Hawthornden is to a turnip. Its flesh is firm and crisp, very juicy and brisk, with a very strong and rich balsamic flavour. The tree is a very early and abundant bearer, almost, if not quite, as much so as the *Hawthornden*. It is ripe in the middle of August, and lasts during the greater part of September. It may even be used in the dessert.

3. *Nonesuch*.—This is a very old and very beautiful English apple, and well suited for orchard planting for the supply of markets, as the tree is an early and great bearer, and the high colour of the fruit is very attractive. It is one of the best for preserving, and makes the finest apple jelly. It is ripe in about the second week in September, and lasts during October.

4. *Wormsley Pippin*.—Among all the varieties Mr. Knight raised, we question if he got a better and more generally valuable apple than this. Besides being of a very large size, and first-rate in every respect for culinary use, it is even a good dessert apple, being crisp, brisk, sugary, and aromatic. But perhaps its greatest qualification is the wide range of country for which it is adapted; it being as easily cultivated in Scotland as in the south of England. It comes in use in September, and lasts during October.

5. *Cellini*.—This is a sort, too, which is deserving of greater popularity. It is handsome and beautifully coloured, and of a good size. It is particularly brisk, juicy, and crisp, with that strong balsamic flavour which is peculiar only to some apples. It is in use during October and November. The tree is a strong and capital grower, and a most abundant bearer. We have only just to look out of the window where we are now writing to see a Cellini tree, about five feet high, which this season was as full of apples as it could hold.

6. *Golden Winter Pearmain*.—This is what is known to most people by the name of *King of the Pippins*, which is, in fact, a *decoy name* given to this variety by a London nurseryman, that he might for a time secure the sale of it to himself. This variety is now pretty well known, and is quite an established favourite, especially in Covent Garden and the other London markets. It is a pretty and handsome apple, and is in use from October till January.

7. *Beauty of Kent*.—One of the most magnificent-looking, and one of the best culinary apples which this country has ever produced. It grows to a great size, and is a fine sauce apple. The tree, however, requires a warm and rather light soil. The fruit is in use from October till February.

8. *Dumelow's Seedling*.—There are few growers now-a-days who do not know the *Wellington Apple*. This is it. It is also sometimes called *Normanion Wonder*. It is a very pretty apple, of good size, and exceedingly firm and weighty. It is one of the very best sauce apples, and well known now in almost all markets. The tree is a strong and vigorous grower, and a good bearer.

9. *Winter Pearmain*.—This, for a cottager's garden, is one of the best we know. It will grow almost anywhere and everywhere, is a most beautiful apple, and

the tree is a very abundant bearer. It is an excellent variety for apple-pies, and is one of those which do not fall away to pulp, but which, though ever so well cooked, still retains the form of slices the same as when first put into the pie. It is in use from November till April, and is a good keeper.

10. *Striped Beefing*.—Very few of our readers know, or ever heard of this variety. The sooner they make its acquaintance the better. We have already exhausted our superlatives on the *Beauty of Kent*, otherwise we would have concentrated all on this. It is an immensely large apple, being generally never less than four inches diameter, beautifully coloured, and the most excellent of the best culinary apples. When baked by itself in a tin, or on a plate, which you will, it falls, and gives out a perfect syrup of rich, sugary juice. It is in use from December till May.

11. *Winter Majetin*.—In appearance this very much resembles the *London Pippin*; but the latter, in ripening, attains a yellow colour, while the former may be kept till May or June, and will always preserve its green colour. It is a very hardy variety, and bears very abundantly.

12. *Gooseberry Apple*.—This is a very valuable apple, not only for its long keeping, but its very fine and peculiar flavour, which, when cooked, very much resembles that of the Gooseberry. It is now coming much into cultivation about London for the supply of the markets, and is a most profitable variety to grow. It comes into use in December or January, and keeps as late as June or July.

We have now completed our list of Apples, and here we leave the subject for the present. Next week we shall, on the same plan, furnish a list of Pears.

We announced, some weeks ago, that APPLES must rise in price before long; and now that time has arrived. During the past week, even although the weather has been so bad, and trade generally dull, the rise has been very considerable. Anything like good samples of kitchen sorts made as much as 7s. and 8s. per bushel, and good dessert 10s. We did not observe anything new among them besides what we have already noticed in former reports. There are still, however, plenty of *Blenheim Pippins*, *Alfristons*, *Newtown Pippins*, *Lady Apples*, and a few *Ribstons*. We observed, also, a small parcel of the old *Calville Blanche*, now very seldom seen in this country, but a great favourite on the continent. These were imported specimens. Among PEARS there is not much new, except a few *Ne Plus Meuris*, a very rich and highly-flavoured pear of the very first rank. It was raised by Van Mons, and named after his gardener Meuris. There are also some *Nelis d'hiver*, *Beurre de Rance*, *Glout Morceau*, and very large specimens of imported *Chaumontel*; all of them make from 3s. to 4s. per dozen.

POTATOES are rising very much in price, even common French kinds of inferior quality are making as high as £5 per ton. *Regents*, of home growth, are £7 10s., and every day they are expected to rise considerably higher.

It is the opinion of good judges that there will not be enough to last out the season.

CUT FLOWERS consist of *Chrysanthemums*, *Camellias*, *Chinese Primroses*, *Fuchsias*, *Heliotropes*, *Heaths*, *Roses*, *Yellow Calceolarias*, *Mignonette*, and *Blue Violets*.—H.

GOSSIP.

In a recent number, p. 91, of the present volume, an inquiry is made after *Dixon and Kerr's Ornamental and Domestic Poultry Book*. We have reason for suspecting that Mr. Kerr is an American, who wrote some time since to the Rev. Mr. Dixon, and that the work referred to is merely a reprint of Mr. Dixon's well-known work which we noticed last week, and we warn our readers from it accordingly; for it would be unjust to the original author to purchase what is pirated, if our suspicion be correct.

Even the little island of *Mauritius* has its Royal Society of Arts and Sciences, and we are glad to see that gardening receives no small portion of its attention. At a recent meeting, over which the Governor presided, it was there stated that *grafting* had been successfully introduced by the society's means, and that two hundred scions had succeeded admirably. Twelve new varieties of the *Pine-apple* were introduced. *Sugar*, however, as might be expected, was the principal object, and we must quote on this subject from the Hon. Mr. Rawson, Treasurer-General of the island. He said:—

"A specimen of that which makes the wealth of the colony (pointing to a magnificent cane on the table sent by Mr. Couvois of Black River), of a size such as no gentleman here ever before witnessed, lies before you. It measures eighteen French feet, and contains fifty-two knots.—There is (said the speaker proudly) the material of our wealth and prosperity. Here is, your Excellency, an evidence of the height to which we have attained, a height to which I hope all planters in this colony are aspiring, and which, if most of them are successful in reaching, will certainly place us at the head of the sugar-growing colonies. Sir, and gentlemen, the medal which I hold in my hand was given to Messrs. Webb and Co. for a sauple of the best sugar presented at the Great Exhibition in London. I think I am correct in saying that they are very, very near getting the Council medal for their production, which, had they obtained, would have been evidence of our sugar being the finest that was exhibited on that celebrated occasion. However, they were second, if not entitled to be the first. Here, your Excellency, is the beautiful medal (handing it to the Governor) which was awarded to them, a medal which ought to be an object of pride not only to Messrs. Webb and Co., but to all the planters, and to every man in the community who takes an interest in the welfare and prosperity of the colony. (Applause)."

But the Mauritians, we observe, also have their *Poultry Shows*, and here is an extract from a report of what was exhibited, and with this extract we will conclude:—

"In Poultry, also, there was great competition, and very superior specimens of *Creole-bred* were exhibited; we particularly noticed those of Mr. Douglas (prize), Mr. Richardson, and Mr. Marie. There were also some fancy fowls of great beauty, and some magnificent capons, which, however, were unrewarded by any prize. We must not pass over Mr. Robinson's superior breed of *Rabbits*, which well deserved the prize awarded; nor Mr. Oliver's *Cape Geese*; nor the

monster *Turkey*, weighing, we learnt, twenty-five pounds! What a mine of truffles it would—but we abstain from depicting 'a sight to dream of not to see,' and adjourn the subject till the December show, which, we hope, will abundantly surpass all its predecessors."

THE following is a list of the *Horticultural and Poultry Shows* of which we are at present aware. We shall be obliged by any of our readers sending us additions to the list, and giving the address of the Secretaries.

HORTICULTURAL SHOWS.

LONDON FLORICULTURAL (Exeter Hall, Strand), Dec. 14†.
SOUTH LONDON (ROYAL), Dec. 16.

POULTRY SHOWS.

BIRMINGHAM AND MIDLAND COUNTIES, 14th, 15th, 16th, and 17th December.
CORNWALL (PENZANCE), January 10th, and 11th. (*Secs.* Rev. W. W. Wingfield, Gulval Vicarage, and E. H. Rodd, Esq.)
HONITON, January 12th. (*Sec.* H. K. Venn.)
SALISBURY AND WESTERN COUNTIES, December 13. (*Sec.* T. Pain, Esq.)

† For seedlings only.

RENOVATION OF FRUIT-TREES.

WHEN we cast our eyes around, and when we call to mind what a vast number of fruit-trees we have met with, or heard of, which disease or unfruitfulness render unworthy of preservation if incurable, it seems astonishing that, after all the books that have been written, all the tales told, and all the fruitist's lore made public, as well as the practical observations of a very many years brought to bear on the subject, such should still be the case. But so it is; and we think some service may be done by dealing out another blow or two at prevailing errors, and pointing to great facts committed with the *root itself*; to the due culture of which all pruning and training must ever hold a secondary position.

Let no one suppose that we wish to decry in sweeping terms the genuine pruner's labours; this time-honoured craft must still hold a place in the annals of horticulture; and we look back with a sort of instinctive veneration on some genuine "early Yorks" whom we knew in our 'prentice days, and who used to sally in the "rest-season," knife in hand, with an expression of countenance fully exhibiting an inward consciousness of their dexterity, and of the great importance of their mission. These were amongst the most patient of men. Years rolled past, and still they pruned on with the utmost precision; "spurring back" with all the exactitude of a walking-stick manufacturer. Indeed, we knew of two of these worthies who were first-raters at walking-sticks, and no marvel either. And fruit *might* occasionally be seen on such trees, which was strange enough; the Pears would occasionally take their stand in bunches at the extremities like tassels; and it was noted, as an odd phenomenon, that the Pears generally commenced where the pruner left off! But our present business is not with wall-trees or Pears alone, but to point to root-culture, for the improvement of unsatisfactory fruit-trees in general; and in order to know what we are about, we must attempt a classification of the evils proposed to be remedied.

As this subject will not be disposed of in one paper, we are in duty bound to prepare the interested reader for it; and the following classification of evils will at once show the breadth of the subject:—

- 1st. Aged trees.
- 2nd. Trees weakened by bearing.
- 3rd. Diseased trees.

4th. Ramblers.

5th. Shy kinds.

6th. Gross, or plethoric young trees.

Before proceeding farther, let us point to the causes of these evils; let us give them names, in order to facilitate a due study of the various causes. The principal will stand as follows:—

1st. Soils of improper texture.

2nd. Soils too rich.

3rd. Too much depth of soil.

4th. Ungenial subsoils.

5th. Atmospheric considerations.

In the consideration of faults in *texture*, we have at once the too light, and the too stiff, or adhesive; the first leading to a kind of leanness in the tree, much averse to the production of first-rate fruit, or to a permanency of habit. On the other hand, there are the clayey loams of extreme tenacity; these, by holding water too long, bring on a debility of constitution, equally averse to profitable results.

Soils too rich.—Most of our readers know by this time that much manure is prejudicial to fruit-trees in general, as inducing an overgross habit averse to the production of blossom-buds; and in addition, in the case of trained or dwarfed trees, causing a most unwarrantable amount of labour to the pruner. There are some exceptions: the Gooseberry and the Black Currant will bear high manuring on most soils; and, indeed, a few exceptions exist in the varieties of some of our fruits. Thus the Manks Codling, one of our very best kitchen apples, will succeed in a rich soil, which would drive a Dumelow's seedling or Normanton Wonder wild. But, be it remembered, that this Manks Apple has the peculiar property of producing bloom-buds freely on the annual shoots; which, of course, creates a greater demand on the root.

Too great a *depth* is the next in our brief review of the evils; the tendency of this is to place the tree beyond that wholesome control which has proved of so much service in later years. We are quite prepared to admit, that in the ordinary orchard, where the object is to produce huge and long-enduring trees, which may pass on to our heirs, without either manuring or pruning, that the soil can scarcely be too deep, if sound; or in other words, if waters can pass freely away at that low level. This is altogether another affair from the dwarfed and early-bearing tree of the garden. And as to the merits of the dwarfing system, when duly carried out, what are the results as compared with the former position of affairs? Then the possessor of a little suburban garden might have a huge Bergamot Pear or a Jargonelle, perhaps a Swan's-Egg; and then there would be the great, old Russet Apple-tree, a gnarled old Codlin, &c., &c.; and these being in bearing, he was therewith tolerably content; for on being advised to plant others, it was ten to one some over-zealous gentleman set him at "composts," and give the ill-fated tree fifty per cent. more manure than the objects warranted. But now, in such a garden, it is becoming no uncommon thing to see an extensive collection, and that, too, in a small compass; in fact, as many kinds as the proprietor can desire.

Ungenial subsoils are not the least of the evils connected with fruit-culture; we speak of those which have received no assistance from the cultivator. Wet and sour bottoms bring on betimes all the effects of age on trees, decayed points, boughs smothered with moss, and a generally lean and debilitated condition. No fine and high flavoured or good-keeping fruit can be expected under such circumstances.

Atmospheric considerations.—Of course an artificial atmosphere is not to be expected out-doors; but if we cannot fit the atmosphere to fruits, we can adapt the selection to peculiar conditions. This is a portion of our subject which has never yet received a fair consider-

ation, even by practical men; it is, however, of much importance, and for the last thirty years—during which period this question, as one of note, has constantly acquired strength—we have seen quite sufficient to confirm the opinion, that it will be well for all parties to give it a consideration. If any reader doubts this, let him try to account for the singular and notorious fact, that a given apple, say A. B., which is a staple commodity in one district, should be lightly esteemed in another. It is of no use saying the soil differs. Soils, after all, are not more material as affecting fruits than the very character of the air itself; and that, it would appear, chiefly based on the degree of moisture where-with it is charged. What makes Cheshire so noted for the production of cheese—its soil? By no means. It is produced in this county from all classes of soils: reclaimed bogs, sandy uplands, and the downhill clays. We do not affirm that an equality exists as to its virtues; but this will not weaken the force of our argument. And then the Damson, almost peculiar to Shropshire and Cheshire, where every hedge-row of the cottager, whether on the clays or the sands, has its thriving Damson-trees.

In many gardens in Lancashire, and other maritime counties, it is no unusual thing to see Peach-trees, in the autumn, with most of their young shoots black and perishing with a kind of gangrene. About twenty years since, when Mr. Taylor was gardener to Earl Wilton, at Heaton Park, near Manchester, he made some new borders for Peach and Nectarine-trees, at a considerable expense, and planted them with capital trees of choice kinds. These trees made the most splendid growth imaginable; in fact, too splendid to be safe. I saw them in the month of October, and poor Taylor was quite puzzled about them; for, having lived previously gardener to the Marquis of Ailesbury, at Sheen, near Richmond, he had not been accustomed to the damp and murky skies of our tall-chimney gentlemen. These borders were twenty per cent. too deep, and sixty per cent. too rich, for the circumstances they had to battle with; and had they been planted *above* the ground level (instead of making holes for them), and the soil a simple upland loam from an old pasture, without a particle of manure on it, the probability is they would not have made half the length of shoot. Here, within thirty miles of Manchester, we never lose a shoot this way; the wood ripens as perfectly as though the trees were in a peach-house; but to be sure, our "stopping" practice has much to do with this; we do not produce wood as sport for the pruner's knife. Now it is not a matter of temperature, let people fancy or affirm what they will; of this we are perfectly satisfied. In order to oppose our argument, some might say, How can we alter the conditions of our atmosphere? We answer, you cannot; but you can alter the conditions under which your trees are situated. It is tolerably evident, that in such climes the trees both absorb more from the atmosphere, and perspire much less; indeed, the latter is the most important fact; for without a liberal perspiration how shall those elaborations freely proceed, which are doubly essential to trees from brighter and warmer climes? Thus we find these men insisting on the necessity for flued walls, by which, it need scarcely be urged, the fruit must become much more costly in its production.

It being tolerably evident, then, that the absorption of too much sap from rich and deep soils is the cause of the failure of such trees, the question is, how to avoid this gluttony? We at once answer, Give them less and poorer diet; put them, as our medical gentlemen would say, under a lowering course, if they become gross, by root-pruning or transplanting; for our readers may rest assured that the pruner's knife can *never* conquer such radical evils. Planting high is of the utmost importance in such cases; and if folks *will have* what is termed

a border, let it be above the ground level instead of below it.

Look at the north of Ireland, and, indeed, other parts of that fertile country, and examine the reasons why they cannot produce Peaches, Nectarines, Apricots, &c., like some parts of England. We were in the habit of corresponding on such subjects, some years since, with Mr. Young, then gardener to the Earl of Enniskillen, at Florence Court, where our singular Irish Yew first showed its face; a mere sport from the common Yew. In such correspondence, Mr. Y. used to give extraordinary accounts of the wild and rampant character of such fruit-trees through extreme humidity of air; not for want of warmth. Broad Beans have been quoted as six feet high, and many other things in proportion. To be sure, the want of more sun-light is a great drawback; but here we are met with another reason for the avoidance of a plethoric habit. Mr. Young has, since those days, gone to Natal, on the African coast; and if ever these pages should obtain a footing amongst the descendants of Ham, we should be right glad to hear from him. He will have a very different account to give of that climate.

In a subsequent paper we will give a detail of cases, with their treatment; and such will surely be fitting matter for the dormant season. R. ERRINGTON.

A VISIT TO THE BOTANIC GARDEN, OXFORD.

THIS is the oldest botanic garden in the kingdom, having been founded in 1632. The first catalogue of plants in it was published in 1648, enumerating two thousand species, of which six hundred were English. Dr. Robert Morison, a native of Aberdeen, was the first Professor of Botany; he was appointed in 1669. Of his three next successors little is known. In 1728, Dillenius, a German botanist, was appointed Professor, and the garden was much improved through the influence and liberality of Dr. William Sherard, who bequeathed £300 to provide a salary for the Professorship. On the death of Dillenius, in 1747, Dr. Humphrey Sibthorp was appointed his successor, and he, in his turn, was succeeded, in 1784, by his youngest son, Dr. John Sibthorp, the celebrated author of "Flora Græca." He died of consumption, in 1796, at the early age of thirty-eight, and in his will bequeathed his books and collections to the botanic gardens. The number of species collected from his manuscripts and specimens amount to three thousand. He also devised a freehold estate of £200 a-year to his own University, for the purpose, first, of publishing his "Flora Græca," and afterwards of endowing a Professorship of Rural Economy. The author of the "Flora Græca" was succeeded by Dr. George Williams, who held the Professor's chair till his death, in 1834, when the present occupier, Professor Daubney, took the reins.

I had a longing desire to visit Oxford, for two reasons; first, to make the personal acquaintance of the worthy curator, Mr. Baxter; and then to see, for the first time, the very garden from which the first ideas of the sexual system in plants was given to the world, from experiments and observations made there two hundred years ago, and before Ray or anybody else had given a thought on the subject. The cross-breeder was received at Oxford very differently from the reception given by Dillenius to Linnæus, whose name is immortalized through the sexuality of plants. Within the last few years, Professor Daubney, assisted by Mr. Baxter, the curator, has made great alterations and improvements in the arrangements of this garden, and their plans are not yet finished. I had some notion that the

Professor had a taste for flower gardening, from his remarks when I once conducted him over a fine scene in that style, but I little expected to find a better taste in the disposition of the flower beds here, along two of the principal walks, than is to be seen in a similar way at Kew. The beds in the angles of walks, at Oxford, and along both sides of the walks, in pairs, are in the best style of the art. They are so at Kew, likewise; but there are no beds in the angles of any of the leading walks at Kew, and there is an outlandish taste in placing five or six feet circles immediately behind each pair of oblong beds, which may be from twenty to twenty-four feet long, writing from memory. The botanic herbaceous plants are planted, chiefly, in circles of different diameters, cut out of the grass behind the flower-beds which skirt the walks, and the trees and shrubs are planted in long borders in such a way as to diversify the surface as much as possible, the situation being low, and without any natural undulations.

The grass garden is also in circles cut out of grass, every species having a circle for itself, and the whole bordered with medicinal plants, and the odds and ends are in borders or strips here and there over the garden. All the walls are covered with half-hardy or nearly hardy plants, and some of them are the very finest specimens in that style I ever saw, particularly a very large full-grown plant of *Spiræa Lindleyana*, on a south-east aspect. It was then in seed at the ends of all the branches, and on an average, the flower branches or clusters were from twenty to thirty inches long, and of immense thickness. It must have been the next thing to the Pampas Grass while it was in flower. The plant is a very fast grower, and last year I recommended to have it made into standards, to rival the Stag-horn Sumach; but, for a cold wall, where plenty of room can be given to it, I would plant it next after *Wistaria sinensis*, and before any other deciduous plant that I can now think of. After that I would plant a strong young plant of *Aralia japonica*, about which Mr. Fish put us on the right scent the other day. The *Spiræa* I would train just like a peach-tree, and the *Aralia* I would allow to grow out from the wall, as you see figs sometimes left untrained. I now see clearly enough that this *Aralia* ought to be treated in all respects like a fig, except the close nailing. *Melanthus major* is here, and at Kew, against walls without heat, and is one of the best of the very old plants that one could plant for the beauty and sea-green of the leaves. The flowers are dull, but so full of honey, that at the Cape of Good Hope they use them for tea and coffee instead of sugar. In very hard winters this needs protection, but if the roots are saved they will soon throw up strong young wood. *Smilax Sarsaparilla* is of the same class, and is convenient for training here and there between specimens of larger growth.

The Olive, Christ's Thorn, (*Zizyphus Paliurus*), the Osage Orange (*Machra aurantiaca*), the oak-leaf *Hydrangea*, *Acacia julibrissin*, a fine thing, New Zealand Flax *Convolvulus scamonium*, *Solanum crispum*, a fast grower but coarser and more common-looking than *S. jasminoides*, are all against cold walls here, with Passion flowers, Banksian Roses, and many other less hardy plants, of which they have a large stock. Also two species of a very scarce plant called *Ephedra* (*monostachya* and *distachya*). One seldom sees these two dwarf evergreen shrubs except in botanic gardens; but they are highly curious, and well worth having, as we have no other plants like them except the *Casuarinas* of Australia, or our own British *Equisetums*, or Mare's-tail.

I must also notice the *Fox Grape* of North America, from among this class, if only to second a suggestion that was lately made by an able writer, to the effect

that these hardy vines from North America would make excellent stocks to work our hothouse grapes on, in preference to growing them on their own tender roots as at present,—a very excellent idea as it appears to me.

After the above, I noted a few out-of-the-way plants which are suitable for a wilderness or for rough banks. *Urtica nivea*—a kind of nettle—a large, bushy shrub, with rough, broad leaves, having the underside quite white, and when they are moved about by the wind, they look singular and very interesting. Another one, of the Currant family, called *Ribes ferox*, looks as fierce and wild as a porcupine. Out of all their herbaceous plants, the two which appeared to me to be most suited for a wilderness part of a garden, were *Phytolacca decandra*, the American Poke, lately described, and *Pyrethrum serotinum*, a very scarce herbaceous plant, reaching nine or ten feet high, with stems and leaves not much stouter than those of a Michaelmas Daisy, and bearing large clusters of white composite flowers on the top, the individual flowers being also large, and easy to be seen a long way off. Whoever grows the old *Astelma maxima*, will find a good match for it in this *Pyrethrum*. Among these trees I shall notice particularly the Maiden-hair Tree, *Salisburia adiantifolia*, one of the finest specimens of it I ever saw; it is a tree that will grow as easily as a Thorn-tree, and every one who plants ought to have this one among the first. *Koelreuteria paniculata*, from China, is another of those fancy trees which every one who wishes to excel in gardening ought to plant.

In all the universities here they teach, among other things, an old Roman doctrine, which says, that "it becomes all men who aspire to excel (in gardening, let us say), to labour with their utmost might, not to pass their life" so-and-so, like so-and-so, but to let the rest of the world understand that they, at any rate, shall not be left behind in the race of garden improvements. Instead of planting ten or twenty trees of one sort, people of this caste would rather plant ten or twenty different sorts of trees, if they only knew the names of the best sorts. The *Koelreuteria* is as pretty going to rest, with its deep, yellow, pinnated leaves, as when the end of every branch is in full bloom, on large, loose pannicles, bearing first, small yellow flowers, and afterwards, large, bladdery seed-pods or capsules. The first tree that attracted my notice, on passing the garden-gate, was a full-grown specimen of the true Service-tree (*Pyrus domestica*) loaded with fruit; here is another tree one hardly sees in a day's march. The Manna-tree, (*Ornus Europæus*), a very, very slow-growing tree at first, is a beautiful specimen here, and so with many others, for which I have no room to-day for mentioning them.

There is a wide ditch on the south side of the garden, and a large pond near the bottom of the garden, in the same direction, and it was astonishing to me to see how many water-plants, from the stoves, they contrived to grow in them all the summer, without any more care than at first to fix them in their places. Those who doubt that most of our stove plants cannot be trusted out-of-doors in the height of summer, and through the autumn, ought to visit Oxford to see these aquatics smothering each other with their luxuriant growth.

Of an opposite family of plants, the Succulents, they have the best and cleanest-growing specimens in England, and a vast number of species of the different forms of *Aloes*, *Mesembryanthemums*, *Cuculias*, *Crassulas*, and so forth, but not many of the *Cactus* family. Many of these curious, gouty plants are enough to make one laugh to look at them. A whole row, on an upper shelf, of little, tiny *Mesembryanthemums*, their leaves fringed all round with rows of teeth, and standing in pairs facing each other, like the jaws of so many puppies of all the dog tribes, and all the cats, and other grinning creatures at full play, such as *caninum*, *agninum*, *vulpinum*, *lupinum*, *tigrinum*, *felinum*, *murinum*, *mustellinum*,

erminum; while *obeordellum*, *testiculare*, *muricatum*, *bifidum*, *spinosum*, *rostratum*, *tuberosum*, *moniliforme*, *taurinum*, and a dozen more of such like, put you in mind of all the drolleries in a toy-shop; and the best of it is, that you could put a score of full-grown plants of most of these into a night-cap; that a little thumb-pot is large enough to grow any one of them; that a little water once or twice a-week in summer, and once in three weeks or a month in winter, will do for them; also that silver sand will do to grow them in; but they will grow in anything; then tell me if it is not worth while to go all the way to Oxford to learn this; and yet the best part about succulent plants is not told, and cannot be told to-day. Among these succulents are two which we might call silver plants, they are so white; they are *Echeveria farinosa* and *pulverulenta*, that is, mealy and powdery-looking. There is one plant of the *Socotorine Aloe*, the finest specimen of the kind, perhaps, in existence, it is so perfect all over, so bushy, so healthy, and so heavy, that four men would find it a good pull to raise it into a barrow, and yet the specimen is not bigger than a full-grown geranium at the London shows. Whether it is the air, the chalky soil, or the great attention they receive, I cannot tell; but there is nothing about London which will come near to the succulents at Oxford for vigour, symmetry of growth, and cleanliness. Perhaps *Crassula perfoliata* is as singular as any of the tribe: the leaves of this species might almost be called versatile, that is, they are so slightly "attached to the stem that they may be turned round at pleasure." When Mr. Fish has a week to spare, he ought to look round London, and see where the best succulents are to be had, and, between us, we could make up a fine selection for amateurs who cannot grow any other kind of plants. We could pick up a dozen sorts that would answer for balconies, terraces, and terrace-gardens, better than the more fashionable plants now in use, because of the novelty of the thing, and the little care needed to look after them. Perhaps Mr. Appleby—now that he has a shop of his own—would hunt out for us the best of the pan Aloes, tree Aloes, and other suitable ones from the other sections.

I shall close this section with a *wonder*—a real tree-pink—*Dianthus fruticosus*. I never saw it, or the like of it before: it has a stem as rough and rugged, and as woody as any plant in the garden, and if the shoots and leaves were cut off, no one could make out the trunk from that of an elm tree dwarfed by a Chinaman. Even as it was, had it not been in flower, I could hardly bring myself to believe that it was a pink at all!

D. BEATON.

(To be continued.)

TRIFLES TO BE THOUGHT ABOUT WITH REGARD TO PLANTS IN PITTS, &c.

It is quite possible to have too much of a good thing. The lady, so admirably pourtrayed in a late number, found this to be the case in regard to the abundance of fruit her garden yielded. Overflowing beneficence was no blessing to her! Many, who nobly buffet with the storms of adversity, lose all balance and self-control when the gale of prosperity comes. Nothing but real evils would ever cure the Mrs. St. Clairs of society of their imaginary woes. Necessity is the chief spur to energy and existence. Without it, there may be strivings and splendid realizations among the few, but there would be sloth and sluggishness, mentally and physically, among the many. What holds true of matters in general, holds equally true in gardening. Fine weather is not unfrequently permitted to do more mischief than the storm. A dull, mild autumn and winter will leave more empty pots behind them than an unusual amount

of frost and snow. In the one case, we are lulled into carelessness; in the other, we are aroused into action.

Already complaints are reaching us about having "too much of the good" of a warm, dull, dripping autumn. Cuttings fairly struck, and secured in pits and frames, are already damping off; and where will they be when April arrives? One person has acted so much on the defensive, that the glasses were kept close, to keep out the dull, foggy, moist air; and when he expected to be able to congratulate himself on his wisdom, the moving of a sash showed Mr. Damp in quiet undisturbed possession. A second has kept them exposed night and day, though many have been rotted off by the surface of the pot; and the soil, in addition to losing its nourishing properties, has been lashed as hard as a brick. A third, knowing that growing plants must not be thoroughly dry even in this weather, has wisely told young *blue apron* to examine all; to take out those that are dry, and water and replace again when drained; and, on his future inspection, he has the pleasure to perceive that the bottom of his pit, so dry erstwhile, is now as thoroughly soused as if a canal from the Nile had been introduced for irrigation. And here, fourthly, is our friend, *Present Time*, chuckling with glee over what he calls, "the stunted rusted things of neighbour *Look-before-him*," who beat him, it is true, last season, but let him look out for the next! "Why, his plants have not budged since October; while mine, from the attention and *heat* I have given them, have grown several inches, and the leaves are as green as leeks." Hint that there may be such a thing as extension, without much addition, and you will be met with a stare, that is designed to tell you, that surely, if great men have found out that *plants are increased greatly in bulk when the leaves are gone*, he cannot be wrong in coming to a similar conclusion when his leaves get fresher every day, and a measuring rule tells him how his shoots lengthen by inches. *These*, and many more cases, I will endeavour to meet in a few directions.

1st. *At all times, but especially in winter, let all stimulants to growth be in proportion to the presence or absence of light.*—It is somewhere about eighteen years since I sent an article to "Loudon's Magazine," disapproving of a high temperature in hothouses at night. Opinions held then have been more than confirmed since—though then I had plenty of reasons, theoretical and practical. The mentioning of these in detail would occupy a number. Let me glance at one or two. In circumstances, as respects heat and moisture favourable to growth, I kept an account of measurements, taken several times a-day, of quick-growing plants. I found that when the night temperature was at all high, increase in length chiefly took place during the darkness of night. The next greatest growth, as respects length of shoot, took place in dull, shady days. In bright days there was always a difference, as respects mere progression, in the case of one plant kept shaded and another fully exposed to sunlight. I perceived, however, that the plant with most light soonest arrived at maturity, bloomed best, and was less subject to casualties. I also found that in the case of such plants grown fully exposed to light, and with as low a temperature at night as to be safe; and, again, of those with a rather high temperature at night, or somewhat shaded during the day—when equal weights of similar-looking shoots were taken from plants thus differently treated, and exposed, first, to the evaporating influence of a dry, heated air; secondly, to being burned in an open vessel; and, thirdly, charred in a somewhat close one—that in every case the hardy light-treated plants produced the heaviest weight of residuum. Then I came to the conclusion, that there might be mere elongation and expansion without much *addition*, on the same principle that out of a small piece of brass the clever worker will manage

to spin out many yards of wire. Exceptions there are, arising from the peculiar nature of particular plants; but, as a general rule, our young friends will do well to bear in mind, that the shining of the sun on the leaves is necessary to solid additions.

What care, then, is necessary *now* for plants in frames and pits, after such a season of warm, dull, muggy weather. Do what could be done, there was too much of the wire-drawing as respects growth. Every thing should have been done, and must continue to be done, to prevent mere elongation, by keeping the plants as *dry* and in as *low a temperature* as to be safe. In general cases, there has been enough of moisture in the *air* to supply plants in such places without watering the roots; and if, during a week's gloom, an hour's sunshine should flag the foliage, it would be advisable then to dew the foliage with a little water, instead of drenching the roots. The very flagging, in such circumstances, speaks of an enervated state of growth; and frequently, when the sun breaks out on a sudden, plants, rendered tender and watery by dull weather, will be most benefited by a slight shading, removing it, however, as soon as it can be done without. On dry days the sashes should be wholly off, when the outside temperature is 40° and above. No rain, however, should fall on the plants, as the moisture, when close, would increase the elongation. In misty weather keep the sashes on, but let air permeate freely beneath them, back and front; taking it away only at night, when there is danger from frost.

2. *Prevent damp from attacking and spreading.* No better weather could have been chosen for the attacks of this insidious enemy. Wherever the plants, in addition, have been kept close and warm, the slender shoots present another favourable circumstance. A low temperature, and abundance of air, as detailed above, are the chief preventives. But even these will not be sufficient. A few decaying and damping leaves left alone will soon spread their contagion. Cleanliness must, therefore, be duly attended to. Not a decaying leaf should stand a day. All the fungous damps delight in garbage. Then the moving of the plants will be a great advantage. You can then roughly rub the outside of your pots; place fresh dry ashes, saw-dust, or boards, for your plants to stand on. Remove a little of the old surface-soil, and fresh dress with dry sandy soil well mixed with powdered charcoal. In delicate cases, a little of this powdered charcoal, mixed with dry sand, and a little, *very little*, powdered lime, and sulphur, may be scattered or puffed among the shoots and leaves. If the frame or pit is deep enough, a raised stage will be a great advantage, more especially if there are means for letting in air, front and back, *beneath* the stage, as well as *over* it by tilting the sashes. In extreme cases, lumps of unslacked quicklime will help to dry and purify the atmosphere. In foggy weather, and there is no artificial means of heating, a few bottles of hot-water, corked, will tend to set the air in motion.

Are all plants usually preserved in such places equally exposed to injury? No. The whole group of Geraniums will suffer little, unless unduly elongated by close heat, and dull weather. Verbenas, Anagallis, Petunias, Senecios, and all of that soft tribe, are easily ruined, and hard-wooded plants are easily mildewed. All the Calceolaria group will suffer little from damp. Half of young beginners ruin *them* by kindness, and a dry atmosphere. If nicely rooted, or commencing to root, they want nothing more during the winter, than to be kept from frost, have plenty of air, and a dusting from the syringe in fine sunny weather.

Suppose we want these plants chiefly for baskets and balconies next season, should we pot them singly in autumn in small pots, put several in a larger pot, or allow the young plants to remain in the cutting-pots? Any way, according to your conveniences, the size you

wish your plants to be, and the state of forwardness in which the cuttings are. Plants in small pots are liable to all extremes, and involve additional labour in routine attention, and any moving they require. When left in cutting-pots, the young plants should be chiefly round the outside, and thus the surface soil can easily be stirred and renovated. When struck moderately early, I prefer placing a number in largish pots, as they are less liable to extremes, and more quickly moved. But for all such stock purposes in winter I approve of wooden boxes—say from two to three feet in length, from nine to twelve inches in width, and from four to seven inches in depth. Any spare boards may soon be converted roughly into such a purpose, and if they have a good painting with quicklime, and be allowed to dry before using them, damps and funguses will trouble them little that season. The chief advantages are—that from the non-conducting properties of the wood, the plants are not exposed to the extremes of heat and cold, dryness and moisture, which they are liable to in small pots, and thus necessary attentions are *minimised*, while all labour in moving from place to place is abridged,—a matter of no little consequence where a limited portion of glass is made subservient to many purposes during the season. When economy in labour becomes a still more serious affair, I shall expect to see, for all out-door ornamenting purposes, with tender plants, pots, and boxes, too, entirely dispensed with, and the requisite number of small plants pricked-out into beds in autumn, there to remain until wanted in the following May.

3rdly. *Watering*.—This has been already alluded to. So few will require anything of the sort, that they had better be removed, watered, and replaced when the extra moisture has drained away.

4thly. *Protecting from frost*.—We have had a few touches of this, and must expect more. Plants in general are in the worst position for resisting its effects. Even under the hardest treatment, the last six weeks has filled them with crude juices, along with a deficiency of solid matter. It is good, therefore, to be prepared. Those who have acted according to the advices of this week would have the plants near the glass. Unless these were on a stage, so as to have several feet of air beneath them, the nearness to the glass, though beneficial in fine weather, would be equally prejudicial in a sudden frost. When there is the smallest likelihood of the *icy king*, it is best to cover the glass at night, even though it would be advisable to leave half-an-inch of air behind. In such circumstances, several degrees of frost would not do much injury, as radiation would chiefly proceed from the glass, or its covering. But near the glass, and not covered, tender, spongy shoots would suffer much from a few degrees of frost. I have hitherto made as simple as I could the whole theory of protection. I could add nothing were I ever so willing. I was told by a person lately, who had read these remarks, that he had built a six-light pit, sunk it two feet in the ground, and left two rows of out-jutting bricks on the back and front wall, so that he could place plants in the bottom, or on transverse platforms of boards, near to, or nearer the glass; and that he meant to have a regular tarpaulin to keep all his glass dry at night in winter, with a softer cloth to lie upon the glass, and to have hay, &c., on it, and beneath the tarpaulin in rough frosty weather. And how could I do other than approve. He rates me, however, that his plants are *damping*, even though he has *dung linings* round the walls; and that the water stands in the bottom of his pit like a canal. Reader! have you any desire to have such a pit; and, for the sake of neatness, and great ultimate economy, do not grudge a little primary outlay? Then build as our friend has done; only have hollow walls if possible, and then they will need no protection; and if not, tie

on them neatly for the winter months, a two-inch layer of wheat-straw. Concrete the bottom of your pit to prevent damp rising; for you have no business to put water there *now*, and a little in summer will be rather an advantage. Raise the earth round the outside of the walls of your pit, so that when beat or rolled firmly there will be a slope outwards of at least one inch to the foot; cover this to the width of six feet with one-eighth-of-an-inch in thickness of coal tar; over that place a layer of gravel firmly rolled, and you may defy outside moisture finding its way within; and then, for protection, tack a lath to the side of every sash—to be removed in summer—and have light half-inch deal wooden shutters, well painted, made to slide up on every sash: and though for such covers for six ordinary lights you pay the best part of two pounds, with ordinary care they will be little the worse for twenty years' wear, while they will enable you to dispense with all other protecting material, except a little litter thrown over them in *very severe* weather. The laths round the sash are both to prevent the covers wearing off the paint, and to enclose a body of air between the glass and the cover. Who, that prides himself on being an amateur, would not prefer examining his pets in cleanliness and comfort, instead of wading among rotting filth and littery, dripping mats?

The same principles will apply to pits and houses heated and used as *Preservatories*. The labour and attention is, however, considerably abridged, as in the dullest, closest weather a sharp fire in the morning, with plenty of air, will promote a free circulation, and thus so far put a damper on damps. Keep in view, however, our first directions.

R. FISH.

CONSERVATIVE AND HEATED FRUIT WALLS.

A CORRESPONDENT (F. H.) writes thus:—"Observing in THE COTTAGE GARDENER that Mr. Appleby remarks upon the Osmaston Manor Garden, and mentions that the garden-walls there are heated with hot water, and answer well, I should feel obliged to him if he would answer the following queries:—

"How large is the boiler? What length of pipe to one boiler? What is the diameter of the pipes? What height is the wall? And are there any gratings in the wall?" Our Editor very naturally sent me these queries to answer; and in order to be quite correct, I sent them to my friend Mr. Lamb, the gardener at Osmaston, and with his usual prompt kindness I had, by return of post, the following answer:—

1st. "The boiler is composed of a series of pipes three inches diameter, connected together at each end; thus forming a boiler seven feet long, which is placed over the fire. 2nd. We have upwards of 3000 feet of pipes to one boiler, but intend to connect another powerful boiler, to be used if found necessary, as there is more pipe to be added. 3rd. The pipes are principally four inches diameter, except the flow and return near the boiler; there they are five inches diameter, in consequence of there being many connections. 5th. There are no gratings in the wall. The walls are about twelve feet high." Mr. L. adds in a postscript, that if any further description is necessary he will be happy to give it. So I would advise F. H. to write to him personally. This correspondence is just the thing that is really useful to such parties as may be about to build garden-walls, either for fruit, like those of our correspondent and the Osmaston gardens, or for growing ornamental plants against, usually called conservative-walls, though, I think, *preservative* would be a better term.

Heated walls have, as is well known, been used for a long period. I well remember, when I was undergardener at a place in Yorkshire (Wheatley Hall, near

Doncaster), what a toil and turmoil the attending the fires was to a young man. The head-gardener would come round with his lantern some cold night in March or April, feel at the wall, and if it was too hot or too cold, would he not storm away at my carelessness! I was young then (it was my first place), not more than seventeen, and could not understand the consequence of too much heat or too much cold to such, as I considered, hardy things as Peaches and Apricots. He was a gardener of the old school, and grew some as fine Peaches as a Snow, or a Collinson, or any other good gardener of the present day. He was a strict disciplinarian, and I never forgot his lessons. His name was Mr. B. Mann, and is worthy of being recorded, for he was a worthy man, and filled the situation for more than thirty years with credit. The walls, I need not say, were then nothing but smoke flues, winding upwards in length of about fifty feet to each fire; so that it was no trivial affair to attend to ten or a dozen fires during the season. Science has done much to ease the labour of the under-gardener. Hot water has not only lessened the extreme labour, but has rendered the necessary attention more certain in its results. One fire, as in the case of the hot walls at Osmaston Manor, is more easily attended to, and the heat is far more equally diffused throughout the entire length of the walls, to say nothing of the great saving in fuel. In my younger days, the idea of devoting a wall to the growth of half-hardy plants would have been thought a most extravagant idea, something like a steam railroad; but now! no garden of any celebrity but must have its conservative-wall. Perhaps the finest example in Great Britain is the one at Chatsworth. I have observed the progress of that wall with great interest. When the idea of growing half-hardy plants against a wall was first acted upon by Sir Joseph Paxton, perhaps nothing more was aimed at than a trial of the cold which certain plants would bear if sheltered by a wall in about the same degree as gardeners shelter the more tender fruits; and the success of the first attempt led to the present splendid example. The wall now extends to the length of several hundred feet, is covered with glass, which extends a sufficient distance to allow walking under it. The plants thrive beautifully and flower magnificently. There may be seen *Oranges* and *Camellias* in the greatest possible luxuriance, the former blooming and fruiting freely, and the latter flowering profusely; also great numbers of New Holland plants, such as *Acacias*, *Epacris*, *Hoveas*, &c., &c., growing so well, and blooming so gaudily as almost to be unrecognisable. I had the pleasure of seeing this famous wall this last August, and a more interesting and beautiful sight in gardening I scarcely ever witnessed. One plant, the *Ribes speciosa*, was particularly gorgeous. This plant is undeservedly neglected, very few gardens possess it at all; yet there are not many plants that are grown against a warm wall that surpass it in beauty when in bloom.

There is, also, a tolerably good wall of this description which was planned and planted by the same able garden architect (Sir J. Paxton), at Tatton Park, near Knutsford, in Cheshire, one of the finest seats in that fine county. It belongs to W. Egerton, Esq. Another wall of this description was mentioned incidentally by my good friend Mr. Fish. He saw it at Wrest Park, and promised to describe it. I trust he will not forget, as the subject of conservative-walls, I assure him, is becoming one of the forward moves in gardening. I saw, on my late journey, many instances on a small scale indeed; but still the idea, and desire to carry out the idea, is progressing; so that any information any of us can give on the subject will be acceptable. I shall try to do my share, and propose to myself to ask and try to answer the following questions. What is the use of a conservative-wall? What is the best aspect? How

should it be built or formed? Should it be heated? Should it be covered with glass? And lastly, What kind of plants should be planted against it? and then give a list of such plants as would be suitable for the purpose.

T. APPLEBY.

(To be continued.)

THE PANSEY.

AMONGST the various tribes of florists' flowers, there are few that attract more admiration than the *Pansy*. It possesses many points of beauty, both in form, colour, and length of blooming season. We find it at all the spring and summer exhibitions, both as cut blooms, and flowering in pots. It is a favourite throughout the length and breadth of the land, and is cultivated largely by almost every florist. As one proof of its general cultivation, I have received a list of kinds or varieties grown by a gentlemen so far north as Berwick-upon-Tweed.

The readers of THE COTTAGE GARDENER, AND GENTLEMAN'S COMPANION (and a very good companion, too, in his garden), will recollect that I invited florists to send me a list of such varieties as they considered first-rate in quality. My Berwick friend was the first to respond to the call, and, in consequence, I send a copy of the list to the Editor. I have no doubt it will be received gladly by our readers, and will be useful to many amateurs, and even dealers. I can vouch for the accuracy of the list, and for the qualities the writer describes.

WHITE OR STRAW-COLOURED GROUNDS, WITH MARGINS OF BLUE, LILAC, PURPLE, PUCE, &c.

Almanzor (C. Mc Laurin); white and purple; a good old flower.

British Queen (Dickson and Co., Edinburgh); white, and fine bluish-purple; beautiful eye; new.

Boadicea; white, upper petals dark purple, belt same colour; very distinctly marked; new and fine.

Countess of Roslin (Downie and Laird); beautiful; straw and rich purple belting; new, and extra fine form.

Duchess of Rutland (Thomson); white, with lilac belt on the top petals; fine.

France Cycle (Grieve); white, and rich deep purple; fine form.

Lady Mackenzie (Stirling); upper and lower petals dark blue, centre very pure white.

Lord Hardinge (Gossett); straw, and bright puce.

Lord Jeffrey (Lighbody); white, deep purple belt, and top petals the same colour; good velvety substance.

Hunt's Helen (Hunt); white and light purple; a fine flower, but sometimes comes indistinct in hot weather.

Mrs. Beck; white centre, rich purple belting; fine eye; extra fine form.

Miriam (Dickson and Co.); white, broad belt, and top petals of the richest dark purple; good substance; fine form; eye large and very dense; new, and extra fine.

Miss Talbot (Dickson and Co.); white, belt and top petals deep purple; new and fine.

Minstrel (Dickson and Co.); white, belt and top petals blue-purple; new and fine.

Royal Standard (Dickson and Co.); white, belt and top petals of a beautiful light purple; new, and extra fine.

Royal Visit (Dickson and Co.); light primrose, and rich deep moreen top petals and belt; good.

YELLOW GROUNDS, WITH MARGINS OF BLUE, LILAC, PURPLE, MAROON, &c.

Captivation (Major); yellow, belted with rich, dark maroon; fine.

Commander-in-Chief (Youell); yellow-bronze, purple margin.

Constance (Thomson); yellow and purple; very constant.

Duke of Norfolk; yellow, and deep maroon; apt to run in summer, but a noble blower when in perfection.

Elegant (Thomson); yellow, and deep bronzy-purple; fine.

Gliff (Dickson and Co.); yellow, top petals and belt fine bronze; large size (has been three inches across); good substance; new and extra fine.

Jubilee (Dickson and Co.); yellow, fine bronze-pace belt and top petals; form and texture very fine; new.

Lady Emily (Sheare's); yellow and bright claret; large and constant; new.

Mr. Beck (Turner); yellow and maroon; good old variety.

Post Captain (Maishment); yellow and bronzy-purple.

Sunbeam (Dickson and Co.); rich, deep, orange-chrome margin, and top petals bright bronze-erimson; blotch large and dense; constant and beautiful.

SELFS.

Adela (Turner's); golden-yellow; large and fine.

Blanche (Turner's); large, white, fine, bold eye.

Duke of Perth (Handyside); very dark; fine and large.

D'Israeli (Hunt); very deep purple, with a shade of blue.

Flower of the Day (Downie and Laird); rich dark plum; bright golden eye, with a fine, white crown; round and good; new.

Lucy Neal (Scotcher's); dark purple; fine.

Magnificent (Neilson); shaded puce.

Satirist (Thomson); bronze; quite a distinct flower.

St. Andrew (Downie and Laird); rich, dark mulberry; of perfect form; new; and a first-rate show flower.

Sovereign (Dickson and Co.); a golden-yellow self; blotch large and dense; new; large and fine form; one of the very best yellows.

Uranus (Dickson and Co.); yellow; large and fine.

My correspondent says, "I consider the above the very best Pansies grown in this neighbourhood; the greater part I have myself, and therefore can speak from experience; the remainder I have had opportunity of seeing in flower, so they may be depended upon as being first class. I do not hesitate to say, that a well-grown bloom of any of them would be an acquisition to any stand."

Such lists as the above, from distant parts of the kingdom, are exceedingly interesting. Many of the varieties, I think, would be desirable to the florists of the south; and the florists of the north will be pleased with a list of the best flowers grown in the south. This list it shall be my business to furnish in my next paper; the space allotted to me now being full.—T. APPLEBY.

(To be continued.)

COAL ASHES AS A PRESERVATIVE TO CELERY, &c.

THE dark days before Christmas being proverbial for their decaying influences, means must be taken to counteract their destructive tendency. It usually happens that the protracted dull and damp weather has the effect of injuring all herbaceous growth, in which the vital powers are not in full and vigorous action: for instance, celery that is full grown begins sooner to decay than the younger or later-planted section—the former having attained a degree of ripeness, which, like maturity in all other cases, is sooner or later followed by decay. To maintain the one and arrest the other is an important duty of the horticulturist. The enthusiastic florist acts in accordance with this principle when he shades his beds of tulips, or other pets—he thereby retards nature's operations in the various functions necessary to the

production of seeds, as well as the ripening of the bulb, or other portion of the plant. The shutting out of sunshine is the means of his retaining in perfection that part of a plant's formation to which he has attached the name "beautiful." Now, though the principle is the same, wherein a plant is preserved entire against decay arising from another source, yet the means to be adopted are so different, that it is only in a literal sense that they agree. The tendency of summer sunshine being to hasten plants on, to accomplish that purpose destined them by nature (namely, to ripen and perfect their seeds, in order to perpetuate their species), is another thing from the hardship of winter acting on a plant of mature growth rendered delicate by artificial cultivation, by which term Celery and Endive may justly be known when they have undergone the process of blanching, which process, by-the-by, is accomplished at the expense of the plants' constitutional hardihood; and though they may occasionally live and prosper after undergoing this debilitating operation, yet, in many cases, they die before the return of that stimulating season which recalls their dormant energies to activity again. That a great number should perish under the ordeal they have been subjected to, need not be surprising, when we consider that the process is all but total destruction at once to the plant. This may appear strange, but it is true; it is only those parts of the plant left to enjoy the action of the atmosphere that keep the others alive: to totally cover all would be a more speedy death than the protracted one, wherein we make the plant part with some of its juices, which we reject as unpalatable; and having done so, we need not be surprised at the loss of health which the plant has sustained in the trial. Productions less robust would have perished under it, but Celery resists decay more than most things, though its endurance has limits; and the earliest "full blanching" of the season will be the first to decay, while the later grown will keep better, and do to succeed it. But then the question is, how is the season of the first-named to be prolonged? how is its decay to be arrested? The question is an important one, but its solution lies in a nutshell. Celery, as well as everything else, is preserved a longer or shorter time in exact accordance with the medium by which it is surrounded; should the medium consist of putrid matter, wet and sour, its contagious qualities may easily be guessed at; if, on the other hand, a good, dry, anti-decaying material be used, a contrary result will be the consequence. Now, I do not use the word dry in the sense it is accepted as a fireside term, because it is folly to think of anything keeping dry that is in contact with the ground, should there even be a waterproof covering over it, loaded as the ground is, as well as the atmosphere, with moisture at this season. It is, therefore, useless to suppose that the term "dry" has any further meaning than as a substance absorbing less water than most other things by which it is surrounded. Ground of a certain description is called "dry," although exposed to every shower that falls. The fact is that by conventional usage we have accustomed ourselves to call it so, because this same rain is, by the component parts of such ground being so open, so speedily carried off, that it is, comparatively speaking, drier than soil of a contrary kind; consequently, we will take it for granted that this porous sandy soil is better adapted to blanch and preserve Celery than the deep loamy kind, strongly impregnated, as it often is, with humous, and other putrid or absorbing matter; but then, many gardens consist entirely of this latter description, which though not the best for blanching this vegetable, is certainly the most suitable for growing it.

Now, it is no difficult matter to grow Celery in one substance and blanch it in another, and many have been the means used to comply with this latter suggestion.

Earthenware tiles or pipes, whole and in halves, have been recommended, and used with more or less success: straw and other bandages have also been tried by some, but the result here has not been satisfactory, affording as it does such an harbour for slugs and similar enemies, it has another bad property also, that of beginning to rot just at the precise time when it ought to preserve itself unimpaired; and by its decaying when the plant is less able to resist its contagious influence, the evil produced is badly compensated by its former utility. Straw, moss, and other litter, is, therefore, to be avoided, and something else substituted. I have myself, after many trials, found nothing so useful as plain coal-ashes; their porosity is such as allows but a small quantity of water to loiter amongst them, compared with other things, while they have a sort of anti-decaying influence in their having so recently passed through the fire, and the way I use them is this—when the celery requires earthing-up, a quantity of ashes is thrown against it by a person on each side of the row or trench, whilst a third one holds the leaves of the plant together; the ashes are then backed-up with earth, and the process repeated when necessary; by this means, no more ashes are used than requisite to enclose the stalk a few inches on all sides with this keeping substance, observing that it is essential that the ashes last of all should be at the summit:—beating the sides of the embankment so as to throw off the wet, is also advisable; but except in very severe, hard frosts, I do not recommend the use of straw, or any other loose covering at top:—it would, doubtless, be better, if the plants could be entirely protected from rain; but since that cannot be, I have little faith in loose straw, or other litter, doing much good that way. Certainly it will exclude frost, and for that purpose it is valuable; but remove it in rainy weather, or the covering up of that part of the plant which has maintained vitality in the wet, will be its utter destruction sooner than it would otherwise be. Another property that coal-ashes have, is the repulsive medium they present to worms and other depredators that prey on the celery when it becomes fit for use; the sharp, gritty feel that it has, together, no doubt, with some obnoxious quality imparted to it in its combustion, makes coal-ashes but little desired by the tribe of enemies the Celery suffers from. These qualifications, united together with their cheapness, and, not the least, their utility in stiff, heavy lands afterwards, enable me to recommend them to the amateur with more confidence than anything else in that way that I have tried.

J. ROBSON.

DAHLIAS OF 1851.

My remarks on the new Dahlia seem to have given pleasure to some of your readers. I proceed, therefore, to fulfil my promise respecting the Dahlias which came under my notice last season. I shall begin alphabetically, so as not to appear invidious, though I dare say I shall offend some of the vendors. If I do, the only revenge I recommend to them, is more care in sending out, and I believe many of them really are desirous of doing right. Let me begin with noticing another fact I have proved, which is, that owing to so many plants being propagated from the roots, and that after being sent out by the advertizing party, the plants have again to undergo decapitation; and after losing the side-shoot, so as to make three plants out of one, the poor amateur gets a chance of blooming his half-guinea plant about the 20th of September! To avoid all this, let every amateur send to a respectable grower in April, with orders to have his plants the first week in May, or not at all. That is my plan.

Another important matter, is to know how to grow your plant when you have it. I will give you my experience. Repot your plant as soon as you receive it, and keep it growing, not in much heat, but with plenty of air. A *nearly-*

spent dung frame, giving only a *little bottom-heat*, is best, just to *swell* the plant, and not let it spindle up. Plant out, the 1st of June, six feet apart. Never cut off any branches, but tie out the shoots; and if they are many, remove them when very young, *but never cut off branches*. I saw some plants this year which appeared like stalks of cabbages, with a few blooms on the top. My plan is to top the young plant, and then the shoots will bloom well by being thinned out, and the centre bloom is generally semi-double. My plants, this year, almost met together, and none above four feet in height, except *John Edward* and *Fearless*, which are very tall growers. This I consider was derived from watering every night *over-head*, not round the root. Just try this, and see the effects.

I begin my remarks with

ALICE (Drummond's); fine colour; in almost every case semi-double, and did not have a good bloom all the season.—*Discarded*.

ALERT (Barnes'); long petal; very thin; dull colour; good eye.—*Discarded*.

ARIEL (Turner's); white; not one good bloom all the season; good colour.—*Discarded*.

AURORA (Keyne's); dull colour; sometimes very fine; hard eye; requires much water. I think I shall try it again.

ANNIE SALTER (Salter's); *peach, like wax*; one of the best flowers I ever saw; requires no cutting out; very free bloomer, and every bloom on the plant I grew fit for show; first-class show flower; rather late; and a good large plant. Should be put out.

ABSALOM (Spary's); amber; pretty colour; rather thin; and late in the season. I had a bloom or two pretty good; shall try it again.

CLOTH OF GOLD (Hooper's); dull colour; very bad.—*Discarded*.

COMPACTA (Gaines'); buff-scarlet; very small; dull colour.—*Discarded*.

DR. FRAMPTON (Rawlings'); very pretty, and fine form. I never had a bloom large enough to show, but I had some very perfect flowers. It must be very much thinned. Shall grow it again, and try hard to get it large enough. Smallness is its only fault.

DUCHESS OF SUTHERLAND (Turner's); fancy purple and white; too thin and uncertain.—*Discarded*.

DOUGLAS JERROLD (Keyne's); this I have seen very fine. I fear it is uncertain; but when caught, it is quite a gem. Owing to its tip, the form is not good and not bearable, except when it has the tip. I shall try it again. Colour buff, with scarlet tip. I remember seeing some blooms good at Surrey Gardens. Cut out the plants by thinning.

EDMUND FOSTER (Turner's); crimson; very full; coarse. I do not like it. Flower round, but not symmetrical.—*Discarded*.

EVENING STAR (Salter's); good colour; thin; poor.—*Discarded*.

FLORA McIVOR (Keyne's); purple, tipped with white. This flower was a gift, and proved a good one. It is very fine, and first-class; fancy flower; not cut out; grows strong.

GLORIE DE KAINE; lilac, black and white striped; a very beautiful flower; good form, and first-class; very certain; grows well.

GLOBE (Turner's); bronzy-brown; new colour; good form; uncertain, but sometimes good. I shall grow it again. Requires cutting out, and good growth.

GRAIN D'OR; orange; dull colour; not symmetrical.—*Discarded*.

GEORGE WILLIAMS (Union); rather thin; good smooth petal. I shall try it again. My plant was very poor, and had no chance of seeing it until late.

JAUN DE PASSY; pale yellow; beautiful colour; very full, but not quite right at the finish; a good flower for the garden, but not for show.—*Discarded*.

JOHN DAVIES (Cook's); not so good as *Cobden*; too rough, and not shaded.—*Discarded*.

KOSSUTH (Drummond's); fancy; not good enough.—*Discarded*.

LOUISA GLENNY (Rawlings'); yellow; one of the finest for form and colour. I grew two plants, one of which gave me all show flowers, the other not one. Requires cutting out. Shall try it again, for, when right, I have seen no yellow equal to it for form.

Laura Lavington (Keyne's); fawn, tipped with white; very fine-formed flower, but came many selfs, and not tipped. Perhaps the season was against it; at all events, it must be grown; we have few such good forms among the fancies yet.

Lilliput (Barnes'); red, tipped with white; very fine, fancy flower; requires cutting out; was very late with me, but first-rate when grown well.—OBSERVER.

(To be continued.)

CUCUMBER PIT.

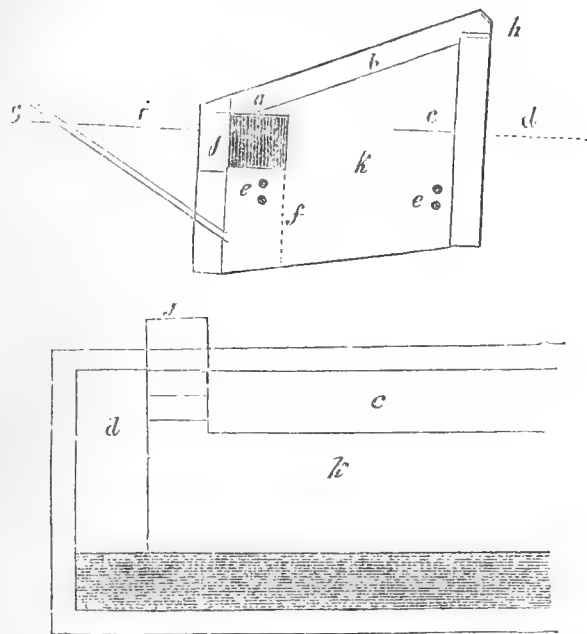

a, the soil; *b*, trellis; *c*, stage for ferns; *d*, stage for ferns, with water-tank under; *e*, hot-water pipes; *f*, brick pillars, to support the slate box; *g*, pipe for admitting fresh air; *h*, pipe for the escape of foul air; *i*, ground-level; *j*, steps by which you enter the pit; *k*, passage; *l*, the wall is built hollow here.

THE above is a plan of our Cucumber pit, which we have now had at work for fifteen months; and as it answers the purpose so well, I thought it worth a corner in THE COTTAGE GARDENER. The pit is forty feet long, four lights of which are devoted to Cucumbers, and the other six for Kidney Beans, both of which I send to table all the year. The soil which I use for Cucumbers, is one part of loam, dug from the pasture, not more than three inches deep; one part leaf mould, and one part old hotbed dung, to which is added a small portion of soot, mixing these well together. When sufficiently dry, it is put into the pit, first draining with bones, over which I put the roughest of the compost. In a day or two the soil is warm enough to receive the plants, which have previously formed three or four rough leaves. I always plant them two inches deeper than they were before, and fill in round the stem with charcoal, as that prevents canker. I find it best to have only one plant to a light, as the Cucumber thrives best with plenty of room. The leading shoot I train up the centre of the light; never stop it till it reaches within six inches from the top of the light, but the laterals which are sent out are stopped at the second joint, and trained out at right angles, exactly the same as a vine managed on the spur system. They very soon break from the second joint, at which time, and always afterwards, they are never let go more than one joint at a time, taking care in stopping not to injure the fruit, which is as yet almost imperceptible. All the male blossoms I take off, as they are of no use, except seed is required, and I never allow any fruit to be produced till the leader has reached the top. I always use water at the same temperature as the soil, which is 75° to 80°; and when I water, I give a thorough soaking, but not again till it is really required, using liquid-manure every alternate time—poultry dung is the best for that purpose, taking care not to make it too strong. The air pipes *g* and *h* are always open day and night, except in very sharp weather, when *h* is closed. I ought to mention that there is one of these pipes under each light. Of course, in very hot weather, the lights are

tilted up at the back; but it is better, in the winter months, to allow the temperature to rise a few degrees than to open them too much for a "blink o' sun," as that, in all probability, would make the plants flag, which is sadly against their well-being. The night temperature I prefer is 60°, and in the day 70°, and 80° if from sun heat, with plenty of moisture often charged with sulphur, as that keeps mildew at arms-length. If this meets your approval, I will trouble you very soon again with a plan of a flower-garden, and also an American ground, accompanied with a few suggestions.—J. RUST, Gardener, Chase-Side-House, Enfield.

WINCHESTER AND SOUTHERN COUNTIES' SOCIETY'S EXHIBITION OF POULTRY.

CLOSELY following on Dorchester and Hitchin, Winchester has now added another name to the list of those towns and districts which have this year initiated themselves in the establishment of societies for the improvement of the various breeds of domestic poultry. This exhibition, for which active preparations had been some time in progress, took place on Wednesday, December the 1st; and, whatever the previous anxiety of those who had been most interested in the success of the undertaking, the subsequent comments of all whom it brought together are sufficient evidence that they did not overrate the interest and attention that it was likely to awaken in the district assigned to its operations. It was, indeed, natural that many would doubt the probability of such general support as more sanguine individuals ventured to anticipate, but it cannot be otherwise than satisfactory to feel that such doubts have been thus overcome, and that some of those who thought least favourably of the project have given the most decided marks of approbation at a triumph so little expected. Everything, indeed, concurred to stamp success on this first meeting of the Winchester and Southern Counties' Poultry Show; the continuous rain of the last six weeks had at length ceased, and a bright sunny day both favoured the travels of the feathered competitors, and aided the necessary preparations for their reception, which took place on Tuesday, and on the evening of that day all were ready for the inspection of the next morning.

The Rotunda of the Market-House, and two large rooms, contained 172 pens, on which we purpose to make some few remarks, in the order they occupied in the Catalogue and the Judge's Award. The latter individual appears to have thought but lightly of Hampshire Bantams as there represented, for although a first prize was awarded to the Gold-laced birds, that was assigned to the pen belonging to Capt. Hornby, R.N., of Knowsley, in Lancashire, and certainly, in colour, figure, and condition, we yield a ready assent to the verdict. A second prize was assigned to this class; and the Partridge Bantams of Mr. Sayers were deservedly admired. The Silver-laced and White Bantams were but indifferent, and the Black ones had no representatives. It may not be amiss to remind our readers, that however desirable size and an upright comb may be in a Shanghae, they are all equally so in the present instance.

Near neighbours were the tiny winners in this class to Mr. Sturgeon's magnificent pen of Shanghaes, which bore off no less than three different prizes, viz., that for the best cock and two hens, with the separate awards for the best single cock, and the same for one of the hens. Weight, colour, condition, and figure, were here displayed in full perfection, and were there room to add another laurel to their owner's wreath, every voice would have at once accorded it; they were pre-eminent, and fortunate would it have been for the Judge if no greater difficulties had come before him than could have arisen from any comparison of these with their competitors. Mr. Sayers' birds, and those belonging to Mr. Gilbert, were good specimens, and could have no discredit reflected on them by suffering defeat from such antagonists.

In Class 3, for a Cockerel and three Pullets of 1852, Mr. Sturgeon's name again appears with all the honours. This class contained twenty-seven entries, of which No. 41 belonged to Mr. Punchard, of Blunt's Hall, Haverhill, Suffolk; the Cockerel was a bird of remarkable beauty in point of

make and colour, the latter a rich buff, powdered, as it were, with orange, gold hackle, and singularly free from any dark feathering; the pullets were equally meritorious as regarded plumage, no less than distinctness of form.

Another year we shall, doubtless, have to chronicle a more even class than were exhibited on this present occasion; birds will then be better matched, and sent in higher condition; but while we venture on this anticipation, let us at the same time acknowledge sincere thanks to all those who were willing to send birds to give *eclat* to this first exhibition, and to encounter criticism rather than run the hazard of empty pens.

In Class 6, a cock and two hens of Mr. Punchard's had a first prize; and, though alone in their class, it would assuredly have been very difficult to have seen adjoining pens equally well-filled. While prevailing taste, as we admit, induces us to regard with longing eyes the lighter-coloured varieties, we frankly admit that the robust character, well-proportioned figure, and delicate markings of such birds as occupied pen 35, will always have great attractions in our eyes.

The class for Chickens of the Brown and Partridge was indifferent; and several points, both as to figure and colour, should have due consideration before another year again sees the Market-house similarly occupied. The possession of five toes will not enable them to perch more readily, or facilitate their movements on the ground. A good pair of white Shanghaes were shown, as single specimens, by Mr. Sayers; and a pen of Chickens of the race came from Mr. Chase, of Turwick. Many of the Shanghaes, competing as single fowls, were exhibited in the Rotunda; while the majority of this class occupied the large room on the left of the entrance; a position, during the whole day, so densely crowded, as clearly to indicate the greatest point of attraction. The single-combed Speckled Dorkings were present in great force and excellence. We concur, however, with the award that gave the first prize to Mr. James Lewry; in whose pen, colour, figure, and substance, were also admirably represented. Lady M. Macdonald had good birds exhibited in this Class; and her Ladyship was also successful in Class 19, where rose-combed birds of the same race competed. Captain Hornby's Cockerels and Pullets in this class stood alone. Mrs. Mills' White Dorkings were shown in excellent condition; and, in shape and substance, left little to be desired; we could have wished, however, that the bill should have been quite free from any dark markings. Their competitors were without blame in this respect, but yielded the palm in respect of figure and condition, in which the winners were pre-eminently distinguished. Game fowls occupied but two pens; of which No. 98 contained well shaped birds; but we could not but regret the absence of other specimens of one of the most beautiful varieties of our domestic poultry.

Golden Hamburgs, both Pencilled and Spangled, were absent from the list. Another year we trust to see this omission supplied; for few members of the gallinaceous tribe will better reward our labours, where external appearance is mainly regarded. But brilliantly were the fortunes of the family retrieved by their first-cousins the Silvers, which, in both the Spangled and Pencilled varieties, were evidently anxious to atone for their relations' absence. Mrs. Mills' Pencilled and Mr. Chambers' Spangled birds were almost safe from criticism, if such an assertion can ever be safely made. The second prize for the Spangled birds was assigned to the pen that took the first prize at Lewes in the present year.

The Malays were but few in number, and, although good specimens were shown by Mr. Sayers, we cannot but hold to our opinion, that in all points they are at least equalled, if not exceeded, by their Oriental neighbours, the Shanghae.

Class 62 presented three very good pens of White Crested Polands—birds that deserved commendation no less for their general figure than for the great beauty of their tufts, which, especially in the winners, were perfectly globular and even. The prize for the best cock fell to the bird in the pen that took the second prize in Class 62. The extreme regularity of his crest, and points of excellence in figure generally, justly gave him precedence, although the fair sex were better represented in the younger birds.

Were it not that we hope to see all classes satisfactorily

represented when another year has passed over us, the Polish family should no longer occupy one pen; but since the Winchester, in common with all other Societies, seeks to improve, we may express our hope that the Golden and Silver-spangled Poland, whether ruffed or otherwise, will then come before us in a more favourable light than that in which we can now venture to regard them.

In Spanish, Captain Hornby met with his usual, but well deserved success; and many a claimant was at hand for the purchase of these much-coveted favourites.

Pigeons were few in number; but a pair of Capuchins and another of Carriers, belonging to Dr. Wesley, of Winchester, were justly distinguished. The Tumblers were fine birds.

In Ducks, Lady M. Macdonald had a pen of East Indian (the Labrador is as entirely a misnomer for these birds, as the term Cochin-China is for Shanghae's). A first prize was awarded for this pen, there being no other competitors; but we should wish to see a fuller display of the golden-green metallic lustre on both ducks and drake.

The Aylesbury Ducks of Mr. Edwards, Captain Hornby, and Mr. Page, fully merited the Judge's award. Mr. Edwards' other pen of older birds were probably passed over on account of their stained bills, a change we were informed that was first perceived at their last moulting. Of Mr. Punchard's Rouen Ducks, our commendation must be strongly expressed—they were excellent in every respect.

We cannot think that Hampshire, or any of the southern counties were at all fitly represented by the Geese that came into competition on this occasion; and its farmers will do well to look to the Toulouse Goose, either pure or crossed with our own breed, to give both size and quality.

Lady M. Macdonald was successful with her Turkeys, of which some bronze-tinted birds carried off the first prize; but this class also will admit of improvement.

No. 168 contained a pair of Guinea Fowls in good plumage.

This ends the Catalogue of the First Winchester Show; and if in its subsequent progress it retains its claim to that public support which has been so liberally, yet so justly awarded to its infancy, the expectations of those who first suggested its establishment will be fully realized, and amply rewarded.

The verdict of Birmingham Judges was at one time the sole authority to which English poultry-keepers had to direct their attention, but now, from Penzance to Yarmouth, and the most northern counties, an eagerness for information is being manifested in these matters, which can only be accounted for on the ground of such details being at length recognized as a profitable branch of farm economy. If poultry exhibitions should prove the means of directing general public attention to this branch of the farmer's revenue, while others are represented in so unsatisfactory a state, the object of their promoters will be fully attained. These Societies have directed their labours, in the first place, to what may prove profitable to the farmer and cottager; and, if in so doing, they can render service to any other class, by gratifying individual taste or inclinations, they will thus gain an additional motive for increased exertions. The multiplication of these Institutions will certainly have one beneficial effect, which we hope, indeed, is already recognized; we allude to the comparison which the exhibitions of adjoining districts must inevitably suggest, and the consequent more definite classifications of those principles on which awards are to be assigned. If the former fact may possibly instigate more minute inquiries into the reasons and authority for such decisions, and thus add to official responsibility, the latter will fully atone for such judicious hazards, by the gradual substitution of a more generally recognized standard of excellence and merit.

The Judge on the present occasion was the Rev. W. Wingfield; and we never knew decisions more generally approved. We will conclude with a List of the Prizes he awarded.

Class 1.—BANTAMS.

5. First Prize—Cock and two Hens, golden-laced, 5½ months old, £12 12s. Captain Hornby, R.N., Knowsley Cottage, Prescott, Lancashire.
9. Cock and two Hens (partridge), one year old, £3—A. C. Sayers, Esq., Clanville House, Andover.
3. Second Prize—Cock and two Hens, gold-laced, three years old—H. Holloway, Esq., Marchwood.
12. Highly commended—Cock and two Hens, gold-laced, 18 months, £2—Mrs. Mills, Bisterne, Ringwood, Hants.

Class 2.—COCHIN-CHINA (Cinnamon and Buff).

- 13. First Prize—Cock and two Hens—Thos. Sturgeon, Esq., Manor House, Grays, Essex; and prize for best Cock and best Hen.
- 16. Second Prize—Cock and two Hens, hatched 3rd of March—A. C. Sayers, Esq., Clanville House, Andover.
- 17. Highly commended—Cock and two Hens, eight months old—A. Gilbert, Esq., 17, Upper Phillimore-street, Kensington.
- 21. Cock and two Hens, Cock 18 months—Mr. H. Higgs, Southampton.

Class 3.—COCHIN-CHINA (Cinnamon and Buff).

- 29. First Prize—Cockerel and three Pullets, hatched in March—Thomas Sturgeon, Esq., Manor House, Grays, Essex.
- 41. Highly commended—Cockerel and three Pullets, eight months—C. Punchard, Esq., Blunt's Hall, Haverhill, Suffolk.
- 32. Commended—Cockerel and three Pullets, hatched last week in March—Mr. Wheeler, Commercial Road, Southampton.

Class 4.—COCHIN-CHINA (Cinnamon and Buff).

- 47. Commended—Single Cock, 10th March—Mr. R. Griggs, Marchwood.

Class 6.—COCHIN-CHINA (Brown and Partridge).

- 55. First Prize—Cock and two Hens, chickens of 1851—C. Punchard, Esq., and prize for best Cock and Hen.

Class 11.—COCHIN-CHINA (White).

- 72. First Prize—Cockerel and three Pullets, hatched 29th of May, £35—G. Chase, Esq., Turwick, Petersfield.

Class 12.—COCHIN-CHINA (White).

- 73. Prize—Single Cock, one year—A. C. Sayers, Esq., Andover.

Class 13.—COCHIN-CHINA (White).

- 74. Prize—Single Hen, hatched 23rd of April—A. C. Sayers, Esq.

Class 14.—DORKING (Single-combed).

- 77. First Prize—Cock and two Hens, 14 months, £5—Mr. James Lewry, Handcross, Crawley, Sussex; and prize for best Cock and Hen.
- 76. Second Prize—Cock and two Hens, old—Lady M. Macdonald, Woolmer, Liphook, Hants.

Class 15.—DORKING (Single-combed).

- 83. First Prize—Cockerel and three Pullets, five months one week, £4 4s.—Capt. W. Hornby, Knowsley Cottage, Prescot, Lancashire.
- 81. Highly commended—Cockerel and three Pullets, five months and one week, £4—Mr. James Lewry.

Class 16.—DORKING (Single-combed).

- 84. Commended—Single Cock, two years old—H. Holloway, Esq., Marchwood.

Class 18.—DORKING (Double or Rose-combed).

- 86. Second Prize—Cock and two Hens, old, £10 10s.—Lady M. Macdonald, Woolmer, Liphook, Hants.

Class 19.—DORKING (Double or Rose-combed).

- 89. First Prize—Cockerel and three Pullets, five months two weeks, £4.—Mr. James Lewry, Handcross, Crawley, Sussex.

Class 22.—DORKING (White).

- 91. First Prize—Cock and two Hens, fifteen months, £3.—Mrs. Mills, Bisterne, Ringwood, Hants; and prize for best Cock and best Hen.

Class 23.—DORKING (White).

- 94. First Prize—Cockerel and three Pullets, six months, £2 10s.—Mrs. Mills, Bisterne, Ringwood.

Class 25.—DORKING (White).

- 95. Commended—Single Hen—N. Antill, Esq., Portsea.

Class 38.—GAME (Duck-wing and other Greys and Blues).

- 98. First Prize—Cock and two Hens, 20 months, £2—G. E. Lowman, Esq., Lyndhurst; and prize for Cock and best Hen.
- 97. Second Prize—Ditto, 20 months, £2 10s.—Same.

Class 50.—SILVER-PENCILLED HAMBURGH.

- 100. First Prize—Cock and two Hens, 18 months—Mrs. Mills, Bisterne; and prize for best Cock and best Hen.
- 101. Second Prize—Cock and two Hens, three years, £1 1s.—W. G. Chambers, Esq., Portsmouth.

Class 51.—SILVER-PENCILLED HAMBURGH.

- 102. First Prize—Cockerel and three Pullets—W. G. Chambers, Esq.

Class 54.—SILVER-SPANGLED HAMBURGH.

- 103. First Prize—Cock and two Hens, Cock and one Hen three years, and one Hen 1852—W. G. Chambers, Esq.; and prize for best Cock and best Hen.
- 105. Second Prize—Cock and two Hens, 15 months—Mrs. Mills.

Class 58.—MALAY.

- 109. First Prize—Cock and two Hens, two years—A. C. Sayers, Esq., Clanville House, Andover; and prize for best Cock and best Hen.

Class 59.—MALAY.

- 110. First Prize—Cockerel and three Pullets, hatched in May—C. Rawson, Esq., the Hurst, Walton-on-Thames.

Class 62.—POLAND (Black with White Crests).

- 112. Second Prize—Cock and two Hens, two years, £10—Mr. T. P. Edwards, Lyndhurst Railway Station; and prize for best Cock.
- 113. Cock and two Hens, seven months, £10—Same; and prize for best Hen.
- 111. Highly commended—Cock and two Hens, 16 months, £3 10s.—Mrs. Mills.

Class 63.—POLAND (Black with White Crests).

- 114. First Prize—Cockerel and three Pullets, five months, £5—Mr. T. P. Edwards.

Class 82.—SPANISH.

- First Prize—Cock and two Hens, 18 months, £4 4s.—Captain W. Hornby, R.N., Prescott, Lancashire; and prize for best Cock and Hen.
- Second Prize—Cock and two Hens, 18 months—Mrs. Mills.

Class 83.—SPANISH.

- 125. First Prize—Cockerel and three Pullets, five months and eight days. £8 ss.—Captain Hornby.

Class 87.—PIGEONS.

- First Prize—For Capuchins, Tumblers, and Carriers—Dr. Wesley, Winchester.

Class 88.—DUCKS.

- First Prize—Drake and two Ducks (Aylesbury), two years—Mr. T. P. Edwards, Lyndhurst Railway Station.

- 157. First Prize—Drake and two Ducks (Rouen), eight months, £3.—C. Punchard, Esq., Blunt's Hall, Haverhill, Suffolk; and highly commended (Rouen), full age, £3.
- Second Prize—Drake and two Ducks (Aylesbury)—Captain W. Hornby, R.N., Prescot, Lancashire, 5½ months, £1 12s.

- 154. Commended—Aylesbury—Mr. W. B. Page, Hill, Southampton.

Class 89.—GEESE.

- 162. First Prize—Gander and two Geese, 1851—G. Bridger, Esq., Chilcombe.

Class 90.—GUINEA FOWL.

- 168. First Prize—Pair of Guinea Fowls, 16 weeks—H. Holloway, Esq.

Class 91.—TURKEYS.

- 170. First Prize—Turkey Cock and two Hens, light-coloured, £6 6s.—Lady M. Macdonald, Liphook, Petersfield.
- 169. Second Prize—Turkey Cock and two Hens, Black Norfolk, £6 6s.—Lady M. Macdonald.

RAPID GROWTH OF SHANGHAI FOWLS.

In calculating the cost of feeding fowls, "Gallus" should certainly make a distinction between full-grown birds and chickens. While it is generally admitted that Cochinchina chickens eat more than others, that full-grown Cochins should eat less than others, will, perhaps, not be disputed, when it is remembered how large a portion of their time is passed in the brooding fit. From the comparative smallness of their eggs, they must eat much less than their rivals the Spanish; and from their natural inactivity, compared with the Dorkings and Spanish, they must require less nourishment.

With regard to those fearful eaters, Cochinchina chickens, it would be well to match them with others of exactly the same age, and to note the increase in weight of each bird. A friend of mine has a cockerel that has increased an ounce each day for some time, and now weighs 12 lbs. Pullets at a certain age increase an ounce each day until after they begin to lay; as they get to the end of the batch, they begin to decrease in weight; but below a certain age, the daily increase is less, on which account the chicks that are matched should be of the same age. I give a list of the increase in weight of seven of my Cochinchina pullets for ten days—

	Hatched.	Weight Nov. 3. lbs. ozs.	Increase.	Weighted Nov. 13. lbs. ozs.
1. May 15	6 2½	10½ 6 13
2. " 25	5 5	8½ 5 13½
3. " 25	5 2½	7½ 5 10
4. June 13	4 15	6½ 5 5½
5. " 13	4 13	5½ 5 2½
6. " 13	4 11½	6 5 1½
7. July 27	3 12½	4½ 4 1

During the above ten days my hens had become broody, and had lost each nearly one ounce per day. I have not been able to prove this time what they lose during a sitting.—W. P. BEEBY, *Chuldon, near Coulsdon, Surrey.*

BRITISH EATABLE FUNGI.

(Continued from page 169.)

Why should we despise what our continental neighbours not only use as a common food, but also consider a luxury? Is it because prejudice is one of the prevailing fashions of our land, which we feel in duty bound to follow; or is it because we have so long been ignorant of the British

edible fungi, that we consider we are now too old to be taught? No markets might be better supplied with such fungi than the English, in spring and autumn, and yet with the exception of the common mushroom, they are rarely exposed for public sale.

Out of at least thirty esculent species (including most of those eaten on the Continent) indigenous to our British isles, only two or three are commonly eaten, and this with agricultural distress and the poverty of the poor, while abundance of nutritious and wholesome food surrounds them on all sides and rots beneath their feet; food which on the Continent not only supplies the edible diet of thousands of the poorer classes, but also luxuries to the rich, which in this land both classes of society are deprived of, and Great Britain continues to be the only country in Europe in which this valuable food is wasted and despised.

Perhaps the undisturbed peace and prosperity of our land, which enables us to cultivate and obtain abundant supplies of the productions of other countries, induces us to believe that our own natural productions are almost unworthy of notice. The Chinese present a striking contrast to ourselves, in the attention paid to their esculent vegetation, having printed annually some thousand copies of a work describing those plants which are suitable for food, and distributing them gratuitously to the poor in those localities which are most exposed to natural calamities. Such an instance of provident solicitude on the part of the Chinese, for the lower classes, may be suggestive in our own land, and a more general knowledge of native plants useful in medicine, domestic economy, and the arts, would be an important and interesting branch of education.

With the exception of the common Mushroom and the Truffle, scarcely a single species is generally known; the Morell is so local and scarce that it seldom appears at table, and the greater portion sold are probably imported. The much esteemed *Cantharellus cibarius* is but little known, except to the Freemasons who keep the secret. I quite agree with Dr. Badham, when he states, that we should be rendering a better service if we applied ourselves to the task of discriminating the esculent from the poisonous fungi, rather than condemn them universally, because we cannot at a glance select the good from the bad, and will not pay that attention to them they so justly deserve, nor does it speak favourably of the superiority of the human race, and the proper employment of their faculties, when they allow the brute creation to surpass them in their diagnosis of food.

I shall now enumerate, separately, the esculent species of most importance, as mentioned by Dr. Badham, commencing with the *Agarics*; in doing this, I shall not pretend to give the discriminating characters, as I consider no one ought to commence collecting them for the table, without some previous botanical knowledge, or the assistance of some botanical friend, in which case, of course, they would possess themselves of some scientific work upon the subject. But should they not investigate the subject themselves, I should advise them not to check the progress of others labouring in the field, while their want of knowledge will not justify them in giving an opinion, as by so doing they may injure others, without themselves deriving any benefit.

Agaricus prunulus.—This fungus is highly esteemed, and much sought after, particularly as it occurs in spring only, when fungi generally are of rare occurrence; the borders of woods and pastures is the proper place to seek it. I have not found this fungus.

A. procerus.—This is a very handsome and delicate fungus, and by no means rare, growing plentifully late in the summer and autumn, on downs, &c. I have found it abundant in Hackwood Park, near Basingstoke; on the common near Odiham; at Hornsey, Middlesex; and on the banks of Loch ———, Ireland. This is a very agreeable, wholesome, and nutritious fungus in its raw state.

A. campestris.—Although most persons would feel indignant were they accused of not being able to select, without doubt, the common mushroom from its thousands of companions, it may be well to remark, that there are several varieties of the common mushroom, and that many of their despised, though equally valuable neighbours, might be recognised with equal facility, if the veil of prejudice which dims the vision was for a short time discarded.

A. exquisitus (Horse Mushroom).—This fungus is much

larger and coarser than the common mushroom, and when stewed I found it hard, and inferior in flavour; it is by many considered superior to the common mushroom for making ketchup, for which purpose it is brought into the markets for sale this autumn. I saw a basket in the Winchester market, and upon questioning the seller, she denied that they were horse-mushrooms, stating that she considered the latter poisonous; from her description, I concluded that she considered *A. procerus* to be the horse-mushroom, which is known to be the most wholesome in its raw state, of any fungi. *A. exquisitus* grows abundant under trees, and in a young state is of a brilliant white, having a pleasing effect in the gloominess caused by our hanging trees. I have found it fine and abundant at Archer Lodge, near Basingstoke, and on the banks of Lough Neagh, Ireland. Abundant in autumn.

A. oreades.—This fungus, of course, is well known as the Champignon, but caution must be taken in collecting, as two poisonous species nearly allied are occasionally found in company with it, namely—*A. dryophilus*, and *A. semiglobatus*; it is of so common occurrence in autumn, forming the fairy-rings, that I consider it unnecessary to quote localities.

A. nebularis.—This *Agaric*, which is considered rare, I have found sparingly at Archer Lodge, beneath fir-trees, has a very agreeable flavour when toasted and seasoned with pepper, salt, and butter.

A. deliciosus.—This I have heard spoken very highly of by several who have used it as an article of diet, stating that it really is as its name implies, delicious; unfortunately I never found but three of this species at the locality last named, and, therefore, cannot speak from experience of its good qualities.

A. atramentarius and *A. comatus*.—These are so similar in appearance, occur so frequently in the same localities, and require the same treatment for the table, that I shall consider them together. I have found them both near Archer Lodge, and on the banks of Lough Neagh, Ireland. I have also found *A. comatus* in a lane near Winchester, and *A. atramentarius* beneath the willow-trees on the banks of the Basingstoke Canal.

A. orcellus.—This, which I consider the sweetest of all the *Agarics*, I found abundant in Hackwood Park, and Archer Lodge, growing beneath the shade of trees in considerable abundance.

The following esculent *Agarics* I have not yet found:—*A. heterophyllus*, *ostreatus*, *rubescens*, *melleus*, *ulmarius*, *fusipes*, *vaginatus*, *violaceus*, *castaneus*, *piperatus*, *virginicus*.

Lycoperdon plumbeum.—This fungus I have found in Hackwood Park; also, *L. bovista*, in Tangier Park, near Basingstoke. The *Tuber cibarium* (Truffle) is also abundant in the beach plantations about Hackwood; also, the *Helvella crispa* I have found in great abundance in the same locality. I have also found it in the plantations at Avington Park, near Winchester.

Boletus edulis and *scaber* I have found abundant and fine in the oak woods at Pamber, Hants; the *B. edulis* also in oak woods at Otterbourne, Hants, and Hornsey, Middlesex; and *B. scaber* very abundant under fir-trees at Archer Lodge.

Morchella esculenta.—I found one plant of this some years back, I regret to say before I knew its good qualities; it was looked upon as an object of considerable curiosity, and then cast away.

In conclusion, I will give a list of esculent fungi on which, as I have not found them, I cannot pass my opinion. *Amanita Casarea*, *Cantharellus cibarius*, *Clavaria coralloides*, *Fistulia hepatica*, *Hydnum repandum*, *Morchella semilibera*, *Peziza acetabula*, *Polyporus corymbosus*, and *frondosus*.

F. YORKE BROCAS.

THE DECOY-POND AND ITS WATER-FOWL.

A WALK of about two miles from my residence, over hilly heaths, brings me to a wild and solitary spot—a sort of deep valley, or glen. It appears as if a whole wood had been sunk into it until the tops of its loftiest trees were brought upon a level with the summits of the surrounding hills. Access can only be had to this sylvan retreat by applying to the keeper, an old Robinson Crusoe kind-of-man, who has

had charge of the place for the last twenty-two years, and who lives in a cottage close by. Furnished with an ignited piece of peat, that the birds may not, by scent, be made aware of any human approach, you enter through a rustic gate, overhung with foliage, and after winding your way for a short distance, amid gloom and underwood, emerge upon the edge of a beautiful expanse of water—a miniature lake, in which the shadows of the surrounding trees are reflected, and their branches dipping. A more lovely and sequestered scene can scarcely be conceived. Upon the water are wild-fowl, diving, sporting, or preening their feathers; these are the decoy-ducks, and this is the decoy-pond. A rivulet enters the glen at one end, and has been stopped up at the other; this occasions the water to overflow its banks and form into a basin; and the water can be raised or lowered at pleasure by means of the sluice-gate. But to render the pond complete for the purpose of taking wild or water-fowl (the terms are indifferently used), it is necessary to have an outlet at each of the four points of the compass, for the birds to pass up, as they will only enter that one down which the wind is blowing. The outlet or pipe, as it is called, is formed by making a cutting about eight or ten feet wide leading from the pond, and gradually diminishing in size as it curves to a point. It is crescent shaped, or resembles in form the blade of a common scythe. Over this arches are fixed, by means of hoops and upright stakes, leaving within the pipe, on each side, a bank of about two feet wide. The arches, or arch, for it is a continued series, tapering to the end, is covered with netting, and when finished exhibits a tube or tunnel. The earth which is dug out of the cutting is placed on the outer or convex side of the pipe, and forms a bank, behind which the decoy-man can pass without being noticed by the birds inside. Along the inner or concave side of the pipe, screens made of reeds are placed at an angle of about forty-five, inclining towards the pond, so that a person standing where these screens converge towards a point can see between them, and command a view of the whole length of the tunnel. There are five of these pipes in this decoy, and these, with a few minor appliances, and a rustic shed or two for holding baskets, tools, &c., complete the establishment.

Water-fowls are winter visitors, and usually begin to arrive in the first or second week of October, and leave at the end of March. Unlike other birds, they feed at night, and resort to the Decoy-pond for rest and security during the day. They are very timid and watchful; nevertheless, their vigilance is overmatched by human stratagem; and their place of safety becomes a trap. The birds principally caught in this pond are, Wild Ducks, Teal, and Widgeon. The Teal and Widgeon prefer deeper water, and frequent a pond near by. 5311 Wild Ducks, beside other fowl, was the number which the decoy-man informed me that he had taken in the last of what he called the good seasons, seven years ago; since which the birds have greatly decreased, and he seldom captures now more than one-third or one-fourth of that number. He attributes this falling off to the mildness of our winters, and the eggs, feathers, and flesh of the birds being more sought after in their native haunts.

Birds rise at dusk, that is, they leave the pond for their feeding places; and it is a beautiful sight to stand at a distance, at sun-set, and see hundreds of them emerge from the centre of the wood like steam of a cauldron; they return again at break of day in small flocks. For the first month after their arrival, the birds are allowed to pass to and fro, and remain in the pond undisturbed: during this time and a little before, the half-domesticated decoy-ducks, which have catered for themselves in the pond during the summer, are fed in and about the pipes, to induce them the more readily to enter them. In the morning, after noticing the direction of the wind, and lighting his piece of peat, the decoy-man proceeds cautiously to reconnoitre the pond, and, if all is favourable for his purpose, he commences the work of capturing: this is usually effected by tempting one of the decoy-ducks up one of the pipes by means of hemp-seed, small portions of which are thrown, from time to time, before them as they advance; the decoy-man, the meanwhile, being concealed behind the outer-bank, or inner-screens. The wild fowl accompany the decoy ducks, and when a sufficient number have entered the pipe, and passed far enough up it, the decoy-

man suddenly shews himself behind them, and the birds rush pell-mell to the smaller end, where they are taken off in a hoop-net, and killed upon the land. Should, however, the birds appear dull and inclined to sleep, recourse is had to the dog, not to drive, but to allure them. He is sent to the edge of the pond nearest to where the greatest number of birds are situated, suitable for working; he there snuffs about, and being regarded by the birds as an intruder, they rush towards him to drive him away—he knows his business, and leads on to the mouth of the pipe, which he enters, continuing along one of its banks, and, by a series of manœuvres, entices them onwards until they are secured and taken as before. Easy as it may seem to write about these birds, it is not so easy to catch them. Much skill, patience, and perseverance are needed; many disappointments are undergone, and exposure to wet, cold, and fatigue, and that for hours together, in the severest weather, have often to be endured by the decoy-man before he accomplishes his object.

The man, his dog, his cottage, and his haunts, have a wild look about them, and particularly the former when seen stealthily moving amid the dark shadows of the wood, with his fur cap on, and which is made to resemble an animal when he is peering over the top of a bank, or fence. In winter, the man is paid by the dozen for all the fowl he takes; and in summer, by the week, for repairing the nets and keeping the place in order.

Wild ducks are fond of frequenting creeks, bays, harbours, and tidal rivers; they hunt along the margins of them for eels, small fish, and crustaceæ; pick up the offal from vessels, and such as is brought down by the ebb-tide from towns. When the weather is mild and open they return to the decoy-ponds, well-fed, dull, and inactive, and are not so easily captured; but in severe weather, and during frosts, their supplies are diminished; fish lie deeper in the water, and crustaceæ deeper in the mud; shallow places are frozen, and the scarcity is often aggravated by an increase of birds. In this state of things they may often be seen upon the decoy pond, sitting on the ice by hundreds, and they are then more active, and are easier taken. The severest season, the richer is the decoy-man's harvest. It is not cold, but hunger which drives wild-fowl from their northern homes. Cold stops their supply of food, and sends it, at the same time, along our shores, whither the birds come in quest of it. In political economy supply follows demand: in the animal economy demand follows the supply; and it will probably be found that the migration of birds and fish are simultaneous, hunger being the motive power, and instinct the governing one. Water-fowl are an index to our fisheries; each species of birds has a predilection for a particular kind of fish; a knowledge of this, coupled with their presence in greater or lesser numbers, may enable us to form a comparative estimate of the state of our supply. What a wide and interesting field for study do the habits of these birds offer to the careful observer of nature who resides upon the sea-coast! They are living barometers, and prognosticate wind and rain, calm and tempest; in short, they are a beautiful link in the great chain of animal creation; they have a mission to execute, and they fulfil it with fidelity and precision; and does man, it may be asked, aided by the superior lights of reason and revelation, perform his part better?

S. P.—*Rushmere.*

THE DORKING FOWL.

WHAT IT WAS, IS, AND SHOULD BE.

I VERY much doubt if our Dorking fowls were ever a distinct breed. It is certain that very few birds bearing this name have much claim to purity. The Greeks and Romans tell of a famed five-toed breed; and so our Dorkings may have been originally derived from that source.

Some years ago, a breed of fowls thus named, bred at Dorking and in that neighbourhood, to supply the London markets, were much esteemed, as are now the large Surrey fowls, which still seem to command the best prices in those markets, as table fowls. Our old Dorkings were a rather small breed of fowls, colour white, sometimes with a few grey or cuckoo-dun feathers sparingly interspersed; they

had a full rose comb, short neck, wide shoulders, full chest, were wide across the hips, had short white legs, five toes, a broad tail, and though not remarkable for laying, were frequent and steady sitters; the chicken came early to maturity, and fattened easily; and were considered the best of all fowls for eating. In some few the hind toes were even triple.

Larger fowls being required for the markets, they were crossed with large sorts, and consequently lost many of their properties; such are the Surrey and Sussex fowls of the present day: of which a great assortment is to be found. These are known by various names, but are generally called Dorkings; of which breed some have one property, some another; some of them are double combed, and others single; short or long legged, four or five toed, being of no particular stamp or breed, and little better than a set of mongrels: their only recommendation is, that they are easily obtained, and, being good eating, are readily disposed of (at a price). Fowls of this nondescript variety of Dorkings are very plentiful in Kent, Surrey, and Sussex, and are considered good by some.

To these some persons are adding a dash of China blood; but they will still bear the name of Dorking fowls.

The improved Dorking should possess all the points of the old bird, with increased weight. Such fowls are very scarce: they appear very square-made birds, and in looking down on them seem almost as broad as long. They should have a large rose comb, short thick neck, short white legs, with five toes; altogether a rather lumpish-looking fowl.

In colour, the cocks are generally of a whitish-brown above, with a black or mottled breast, and black tail; somewhat approaching to the colour of a game cock called a Duckwing. The hens are grey, with light hackle, and sometimes slightly speckled with white. I do not, however, consider the colour of the feathers of much importance if the other properties are strictly adhered to; in which case, I think a good Dorking fowl will be found to have less offal than any other in proportion to its weight. The cocks often weigh 7 lbs., and the hens from 5 lbs. to 6 lbs., and some even more.

I fancy the Dorkings are more subject to Roup than are other varieties; as also to diseases of the feet; and that they lose their productiveness earlier than many varieties. But I am of the opinion, that if breeders would pay more attention to the properties of those birds they keep for stock, always selecting the best shaped and healthiest fowls, and never allowing them to breed in-and-in (that is, not to let too near relations breed together), but continually introduce fresh blood, being careful to select fine birds of the same variety for that purpose, they will soon find their stock improve, as well in health and beauty as in profitableness.

Bessel's Green, near Sevenoaks.

B. P. BRENT.

THE MUSK DUCK.

At a time when we meet with so many well-written articles in your columns upon the relative qualities of the different breeds of fowls, it may not be out of place to notice those of any other species of poultry. It is the Musk Duck that I would draw attention to. I have kept them four years, having purchased a fresh-imported pair direct from South America. I find them great layers, good breeders, producing two, and often three broods in the season. The eggs are mild and well-flavoured; the flesh delicious. The drakes will, if well fed, obtain the weight of seven pounds and upwards at three months old. As a proof how prolific they are, I have had, the last two seasons, broods from ducks hatched early in the spring. I have now a brood of six, five weeks old, by a duck hatched in February last, doing well. One most desirable property is (like the Cochinchina fowls), nothing seems to hurt or put them out of the way, they are so very docile. A CONSTANT SUBSCRIBER.

MERITS OF DIFFERENT VARIETIES OF FOWLS.

We have received so many letters upon this subject, that we can do no more than select from the facts they contain, re-

jecting, without any favour, the mere expressions of opinion; for these coming from anonymous correspondents are not weighty authorities.

ENDURING QUALITY OF SHANGHAES.—*Gallina* says, "I can find a hen, imported some six or seven years ago, and not very young then apparently, that has produced this season chicks from her own eggs. As for food, good barley being at 3s. 6d. per bushel, it costs me far less than 3d. per week each, and they eat until satisfied."

EXPENSE OF SHANGHAES, &c.—*Gallus secundus, M. D.*, declares, "So clearly have I been convinced of the positive extravagance of these birds, that I have been reduced to the miserable expedient of a pun, by asserting it to be as expensive to keep a Cochinchina as to keep a coach in China! They are, indeed, veritable cormorants, and I may exclaim, with the judicious "Thomas," that two will eat as much as a pig. My experience is most unquestionably to the effect, that the Spanish are the best layers. They lay more frequently, and their eggs are larger, but they are not so good for the table as the Dorkings. The Cochinchinas are decidedly good layers, and their eggs are very rich, though small in comparison with the Spanish."

MANAGEMENT OF SHANGHAE FOWLS.—"It may be interesting to you to know that, with the exception of a few ducks, my stock consists entirely of Cochinchinas. I keep five hens and a cock, as breeding stock, having had them presented to me by a friend, who imported them last spring. I have bred several pullets this year, which promise to be better than the old birds; and my idea is, to keep them as stock for next year, and to procure a very good cock. I hope by doing so, to improve my breed; and, by selecting my best pullets annually, and changing my cock, to bring my stock, in the course of time, to something like perfection. Is this the course adopted by successful breeders? [Certainly.] In feeding my poultry, I adopt the plan of always having food in the troughs, which sometimes consists of brewer's grains mixed with meal, and sometimes of boiled potatoes and meal. In addition to this they are fed (by hand) three times a day, with as much wheat or oats as will satisfy them; and, since last spring, I have ascertained that the cost of keeping old and young has not averaged 1d. per week each: in fact, up to the 1st of September, the cost was only about 3/4d. per week each. This, of course, is exclusive of scraps from the kitchen; and I may add, that they have the run of half-an-acre of grass land. In selecting pullets as stock birds for next year, I have chosen all of a light buff colour, being convinced that they are not only the most handsome, but quite as hardy as the dark variety."—T. J. O.

COST OF KEEPING FOWLS.—S. states, "For the last fortnight my stock has consisted of fifteen Spanish Fowls, viz., a cock and two cockerels, three hens and nine pullets, the youngest hatched in the beginning of last April, and although they have had free access to barley at all times during the fortnight, they have not quite consumed two-and-three-quarter pecks, which, at present prices, cost in this part of the country about 2s. 3d. My fowls have the run of about twenty perches of land, part grass and the remainder gravel, and in addition to the barley there has been given them daily, part (another yard of fowls taking their share) of the refuse of the kitchen, which I should think was over-valued at one penny a day, but say 2s. 10d. for the cost of the food of fifteen fowls for two weeks, or a trifle over 1d. a week per head. I have kept poultry for some years, and have found, after repeated trials, that a quarter-of-a-pint of barley per day, for every full grown fowl, with a grass walk not exceeding a quarter-of-an-acre, is rather more than will be consumed."

NOTES ON BEES.

I HAD contemplated that the subject of my next offering of Notes on Bees to the pages of THE COTTAGE GARDENER should have been entitled "Spring management on the moors," as a sequel to my last. But the year is gliding on so rapidly, that perhaps a review of the last season, in reference especially to the bees themselves, is more in place at present, and soon we shall look prospectively to the work of the coming spring. From the accounts received from all parts of the kingdom, it is evident that the apiaries in the

north have been more highly favoured than the southern sisterhoods. Though the spring had been unusually dry, many hives in early situations were ready for swarming the beginning of June, about the usual time in ordinary seasons; then came three weeks of chilling rains, when those bee-keepers (I am sorry to say they are still numerous), who maintain that bees which cannot support themselves are not worth assisting, lost many of their stocks. In some hives the royal nymphs were destroyed (in common hives this symptom of distress cannot well be ascertained); drones and larvæ (a certain sign of starvation) were brought out; while in others, without any of these precursors, families 20,000 strong ceased to exist. At last, when fine weather came, in some apiaries those hives which had received timely assistance swarmed with a determination which it was impossible to check, and in others the design of swarming was entirely abandoned. It is often difficult to understand the operations of the bees, from the very numerous combinations and circumstances which affect them; in these opposite results I am inclined to think that in those families which had been prepared to swarm two or three weeks previously, the queen had at that time finished the *great laying*, constituting the swarms; in fact, a quantity of eggs had been probably wasted, and thus, on the return of fine weather, there was sufficient vacant space for the storing of honey, as well as the deposition of eggs, in which, as Dr. Bevan observes, there is usually a relaxation in July. On this point, I only speak as compared to the prior laying, the queen still produces them in considerable quantities, as may be seen by examining the combs a few days after the swarm has been established, when many square inches will be found occupied with brood. According to the statement of Huber, in which Dr. Dunbar coincides, the diameter of a worker's cell is two and two-fifth lines, thus one square inch comprises fifty cells, including both sides of the comb. Dr. Bevan gives the dimension as two and three-fifth lines, which I think will be found the most correct measurement, and still affording a wonderful proof of the economizing of space.

The letter of Mr. H. Taylor, for the perusal of which the readers of THE COTTAGE GARDENER are much indebted to Mr. Payne, suggests subjects of deep thought to the apiarian. On the comparative merits of old and young queens, I will beg to offer a few remarks. As far as I am able to judge, more from attentive observation than lengthened experience, I am led to the opinion that a young queen will be equally prolific from the day she begins to lay eggs, *provided* all contingencies are alike. However, it must be borne in mind, that a young queen, established at the same time, and with as strong a colony as an older queen, commences her sway under much less favourable circumstances. A week, a fortnight, or even longer, elapses before she commences to lay eggs; and those apiarians whose hives enable them to view the whole body of bees at once, cannot fail to have been struck with the rapid diminution of their numbers during the working season, when there are no young bees to replace those that are lost. Then, as in spring, poverty in numbers is the parent of poverty. I have seen a queen of two months old, from this cause, laying her eggs "to mere waste," and have counted as many as three and four in one cell, while others were dropped and devoured by the workers. With profound respect for royalty, I admit having detected a queen condescending to deception. I found one of my young queens, this year, going through the routine of depositing eggs, examining the cells first, as is their wont; having reason to doubt this fact, I took out the window, and, making a minute inspection of the cells, found there was not a single egg. Next day she began to lay in earnest, but in another comb, and within a fortnight honey was stored in the cells where she had been *shamming*. But this is a digression, and I return to find further proof in favour of young queens. We have it on such good authority as that of Mr. Golding, that she has been known to lead off a swarm a few weeks after her birth. The second season in one summer enjoyed by bees near the moors, offers a full test of her powers. There we find stocks depopulated by swarming, and second swarms labouring under the disadvantages above-mentioned, returning to their owners with as large a population as their elders possess.

For instance, this season a second swarm filled a Grecian hive, and stored six or eight pounds of honey in a glass; while of four hives sent together to the moors, three of which were swarms, and one a stock which had swarmed twice, the stock came home decidedly strongest, so full, indeed, of bees, that had the season been May instead of the end of October, I should have looked for a swarm in a few days. Yet I do not imagine a queen deteriorates before her third year at soonest; and I am glad to see so experienced an apiarian as Mr. Taylor, is of this opinion, as well as Mr. Golding, whose "old lady," at four years of age, swarmed when she was dead!

This letter is already so long, that the consideration of queenless stocks and drone-laying bees must be deferred to another opportunity, if my pen should be again employed in transcribing from notes on bees.—INVESTIGATOR.

TO CORRESPONDENTS.

WEIGELA ROSEA (N. B. E.).—Surely you must know that the rose and the vine flower on wood made the same season; or, in gardener's language, on the current year's growth. The difficulty lies in this, that both the vine and the rose have been, or may be, pruned as close as to the last eye of the young wood, and to any other eye from the last to the one at the end of ten, twelve, or fourteen feet; therefore, they are not very good examples to teach the pruning of other plants from. It is a rule that ought not to be slightly broken, that all plants, when removed from one place to another, or transplanted, should be pruned in some way or other. Roses, low plants, and shrubs, like your beautiful Weigela, should be cut down to within a few eyes of the young wood; and stronger things, as large trees, only to be thinned of shoots, or cut according to the extent, the vigour, or the mutilation of the roots in the removal. But cases do occur, and yours is one of them, where it goes against the grain to fulfil the laws of pruning to the letter. For fear of misleading others, we must state your case before we advise you, however. You planted your Weigela this autumn, and it has from fifteen to twenty shoots rising directly from the crown or collar of the plant, their average height being three feet. This tells a tale. This plant was too large for the space for it, or else it was too straggling, and they cut it down to the ground to renew it. The shoots are now too numerous for a plant not transplanted; and one that has been lately removed must have about one-half of these shoots—the weakest ones—cut in from three to six inches in length; then take *three* of the strongest shoots, not cut, in your left hand, and cut off five or six inches from the points—then let them go; now, with your eye, measure the *best distances* between the top cuts and the bottom cuts, for cutting back the remainder of the shoots at different distances. Give the plant a good watering in April, three in May, and four in June—three or four gallons each time—and let us hear next August how it looks, &c., &c. In another year you will cut out all the very weak shoots and as much of the older wood as will keep the head regular, and the young shoots you will cut back, some to one-half their length, and some to one-third.

SHADED BORDER (R. A.).—What will grow on a five-foot-wide-border sloping a little to the north-west, and shaded with high laurels that may be cut down considerably? This question admits of many answers, yet none of them might be to your liking. Tell us what you would like there.

PRUNING STANDARD CHINA ROSES (A. J. F.).—It is not easy to answer about the pruning of monthly China Roses that are now straggling. The smallest Roses known are among the monthly Roses, and the very strongest also, as *Indica major*, and every degree of strength between these extreme points are also found in monthlies. Now, we all know that these, and every other Rose, will get straggling in time, unless they are attended to; but about the pruning of monthlies, without knowing what kind of monthly they are, is more than is safe to undertake honestly, without writing an essay to include all the possible shades of pruning. In a general way, very strong Roses must not be pruned at all on standards; that is to say, not much shortened; whole shoots cut out entirely, to leave more room for others, is the rule; standards, not very strong, may be pruned according to the degree of strength, without reference to what section they may belong to; and weak-growing standards must be pruned close, under any circumstances.

TROPÆOLUM TRICOLORUM (Michel).—There is nothing unusual in your plant starting vigorously and making as yet few leaves. You will have plenty by-and-by; the symptoms are *quite promising*. Do not give too much water in this dull weather. Let the pots be filled with roots before you soak the soil freely.

PLEROMA ELEGANS (Ibid).—How and when to propagate? In early spring, take off the points of half-ripened shoots; or, better still, select some shrubby side-shoots from two to three inches long; cut them across at a joint, and remove one or two tiers of the lower leaves; then plant them firmly in silver-sand, over sandy-peat, well-drained; water; allow to drain, and the tops to dry; then place over them a bell-glass, and plunge the pot in a sweet, mild, bottom-heat. After a few days, lift the corner of the glass at night, to prevent damping and to admit fresh air, and replace the glass firmly again in the morning, shading as much during the day as will prevent the shoots flagging, and no more.

WATSONIA FULGIDA (Troublesome).—This growing in the border, may be left there with the protection of a hand-light; but we think you would be better pleased with the blooms if you lifted it carefully, potted it, and kept it in a cold pit during winter.

BIGNONIA RADICANS MAJOR (Ibid).—The pot of this has been cracked, and then inserted in a deep, rich border, but the plant has not grown more than twelve inches since May. Examine the roots; remove at least part, if not most of the pot; and trace out the roots with the hand, and give them a little sandy-loam and peat, or leaf mould, to ramify in at first, and you will, most likely, have growth *enough* next year.

T. B.'S MODE OF PROPAGATING AND PRESERVING VERBENAS (*Ibid.*).—This mode is at page 374 of our last volume. We cannot say whether T. B. possesses a mild climate or not. In any climate in this country his mode would answer well for propagating; and with care in protecting, especially with waterproofed material as overalls, we should see no great difficulty. We are, however, no advocates for hand-lights for such purposes. You might have a glazed frame, and each light would cost you little more than a glazed hand-light, while there would be no comparison of the available surface-soil. In a frame or pit they would keep nicely under such treatment, and involve less labour than under hand-lights. See what Mr. Fish says to-day.

ALLAMANDA IN POTS (*A. Bartleman*).—You speak of having large old plants, and ask when to start them? As soon as you like. Cut back the long shoots of this year's growth to from six to twelve inches of the previous year's wood, allowing the leaves to remain on the wood left. After that, just see that the soil is not dry, as it is desirable to swell the buds left. An average temperature, from 55° to 60° at night, will do. When the days lighten and lengthen, in February, or before, add 10° or 15° to the temperature, and syringe the stems as well as water the roots. When the young shoots are several inches in length, give what shifting the plant requires, using rich rough loam and a little peat, and a pot not less than twelve inches in diameter, and a trellis at least three-and-a-half feet in height by two-and-a-half in diameter. When freely growing, give manure-water liberally. Success depends upon the vigour of the young shoots, and their being well exposed to light. *Allamanda nerifolia* may be grown in a pot as a shrub; the others require a considerable amount of room, whether on a trellis or a rafter.

VARIOUS.—*Margaret*, living in North Wales, kept 260 plants last winter in five windows, including Verbenas, Petunias, &c.; but has no greenhouse. 1. *Lotus Jacobæus* is rather a bad thing to keep; you did right not to pot it. You should not have given it a very rich compost at this season as a top-dressing. Prune away all the decaying and withered parts, and give no more water than will just keep it from flagging; and if you preserve life it will thank you for all the labour next summer. 2. *Lily-like plants*.—We can hardly make out whether your plant is a Lily, a Calla, or an Arum; but in its present symptoms you had better let it die down, but not to be quite dry. Any darkish place free from frost will do. 3. Your *Fern-looking* plant keep rather dry for a few months, and then water it freely. It is hardly worth growing. 4. *Mimosas* that have lost their leaves.—Do not repot now; just keep them a little moist at the root, but they will want little water until the leaves break afresh in the spring. We fear they will be rather strong-growing for the window. Before they break they will not require much light. 5. *Astromerias* nearly dying down.—Give them no water. They may be kept anywhere, where shelter from frost and wet can be afforded them. If you intend to grow them in pots, fresh pot before growth commences. 6. *Tropæolum* on a trellis.—Do not interfere with the tuber until the foliage has withered, nor for a short time afterwards. You may then take it up, place the tubers in a small pot surrounded with earth, and give no water; but when the young shoots begin to move, pot in a similar pot to that the plant is now growing in. Any place in the room will do now; it must have all the light possible when growing. See another answer to a correspondent. 7. *Cactuses*.—Do not think of moving them to a dark place; give them what light you can. Give no water unless they shrivel much, but avoid the least frost. Your success is very creditable to you; your mode of giving air in winter by the top of the window is admirable, and knowing such results lightens labours that otherwise would not be easily borne.

NAMES OF PEARS (*G.*).—*Passé Colmar*. (*W. B. N.*).—So far as we can judge from the sketches sent, and taking it for granted that the fruit is at maturity now, we should say No. 1 is *Passé Colmar*, and No. 2 either *Calebasse*, or *Beurré Bosc*; but this, of course, is mere guess-work in absence of the fruit itself.

ORCHIDS (*A. M. S.*).—Such delicate flowers as you sent should always be put into a tin-box, and be packed amongst soft, damp moss; put between thick paper as yours were, they are sure to be crushed coming through the post-office. They were flattened, and the colour squeezed out completely. As far as we could judge, they are—No. 1. *Zygopetalum Mackayi*. No. 2. *Zygopetalum crinitum*. No. 3. *Marillaria picta*.

GLADIOLUS GANDAVENSIS (*Cuto*).—This should have been planted last month, but as the weather has been so dreadfully wet they may be planted now, or as soon as we have three consecutive fair days. Mr. Appleby is preparing lists of all the best florists' flowers, and will give the *Chrysanthemum* very soon. For its culture see the back numbers of *THE COTTAGE GARDENER*, or *The Cottage Gardeners' Dictionary*.

ZERO.—We have written to the gardener, and as soon as we receive his answer you shall know.

LAYERING CARNATIONS (*A Real Cottager*).—You do not say whether you grow your Carnations in pots, or in the open border. We suppose the latter. You may thin out the shoots, if numerous, and peg the remainder down the same as if you had layered them, only do not cut off the ends of the leaves. Lay a little good, rich earth over the bare shoots, and do not neglect to layer them next August, or they will most probably run their colours. It is a great pity you have not layered them, for even with the above care you will find them much injured in respect to the properties they would have had had they been layered at the right time.

VARIOUS (*C. C.*).—*Combretum Purpureum*. Plant this as you propose doing in the back border near the furnace. *Allamanda Schottii*, keep in a pot at the warmest end of the house; but we give you little hope of doing good with either, if your house is merely kept from being lower than 40° at night. Let it range from 50° to 55°, and you will find all will do well; but those heats would be too high for common greenhouse plants. The *Ipomæa* best next to *Learii* for a greenhouse, and not liable to spider, we think, is *Sellowii*. It will contrast with *Learii*, being a reddish-pink. But you must keep your eyes about you, as every *Ipomæa* is liable to spider if not duly watered and syringed. *Jasminum Sambac*. This you can only grow successfully in the temperature recommended above for *Allamanda*, though 5° less would do if not of long continuance; then give it a warm position. But if 40° to 45° be your average range at night, I would advise you to substitute *Jasminum gracile*, or *J. grandiflorum*, in its stead. The *Gracile* is a very short thing, that will do well either in a pot or against a pillar.

These two hints we would give you as a young beginner. 1st. Do not make a bugbear of insects. Every plant is subject to them if neglected. Care and attention will always keep them at a distance. We have seen people in a pretended agony about an insect-covered plant in a window; and yet five minutes use of their own fingers, and a drench from the rose of a water-pail, would not have left the vestige of a living thing upon leaves or stem. 2nd. Never go to the expense of getting large plants in pots like the *Combretum* sent to you, until you have previously ascertained if such a plant will suit your circumstances. As you have got it, try it in the place indicated. Your warm position and full exposure to sun may do much.

POLAND versus HAMBURGHS OR DUTCH.—"In *THE COTTAGE GARDENER* for November 18th, I observe a correspondent complains, that I have endeavoured to overset a uniformity of nomenclature respecting the Dutch Every-day-layers. I beg to state that such is not my desire; I only oppose the application of the name of Hamburgs to them, as it is the only one by which the mongrel Poles are known; whereas, the Dutch Every-day-layers have many, and ought to be satisfied. A 'Fowl Fancier,' at page 134, of the same number, while speaking of the Shanghaes, says:—"It is a libel to call the gangling, half-Malay creatures, which are so common, by the aristocratic title of Shanghaes." Now, this is exactly my opinion about calling the Hamburgs Poles. And, however unpleasant it may be to those keeping them to be told, that the least appearance of comb shows impurity, it is nevertheless true. My wish is to have things called by their right names, and to save, if possible, the true Poles, ere they become extinct. It is no new scheme of mine; for if your correspondent will refer to Mr. Trotter's Prize Essay, as it stands in *The Royal Agricultural Journal*, he will find them noticed separately there, although he has altered it in the separate edition of the same. Mr. Dixon's description of the Poland fowl I do not consider taken from good birds; but Mr. Richardson's description of them is excellent; but in the later enlarged edition of his work, some friend has tried to make him fashionable too, by mixing together what he had separated. I have not read Mr. Bailey's book, but will do so. It has become too much the fashion to call all tufted fowls, Polands, and all five-clawed fowls Dorkings, which I consider greatly injures the purity of those varieties."—B. P. BRENT.

SUTTON IN SURREY (*W. E. J.*).—The soil of which you require information in Surrey, is a fair, thin, sandy-loam, resting on the chalk formation. It is well adapted to the cultivation of common fruits, vegetables, and flowers. In that county, not very far from the place you name, there are large fields devoted to the cultivation of Lavender, Peppermint, Chamomile, and other flowering plants—we allude to the adjoining parishes of Mitcham, Carshalton, &c. Water is there obtainable from either wells, springs, or rain. Let "W. E. J." remember that it is found that sufficient rain falls on every house in England to supply its inmates with water. As to the rest, consult any Croydon land-agent or auctioneer, such as Blake, or Fuller, or Stedall.

ERRATA.—At page 143, for *Azalea* read *Aralia*; at page 143, for *Tilsoe* read *Silsoe*.

MR. STURGEON'S SALE (*A Fancier of Cochins*).—Lot 101, the cockerel by Jerry for which £12 10s. were given, was bought by Mr. Hodgkinson, of Birmingham.

WORKING GARDENERS' SOCIETY (*A few Working Gardeners*).—Let us know what funds you have or can command.

BOOKS (*I-forget-my-Name*).—Buy Loudon's *Self Instructor for Young Gardeners*. You do not want any instructions for preserving botanical specimens. Put each between several sheets of blotting-paper, and press it moderately till dry.

DAMP (1001).—"Steam" is not generated in a cold pit, the damp condensed on its glass arises from the exterior cold causing the air within to deposit its moisture. You understand our directions quite correctly as to the application of the peat, &c.

REMOVING VINE BARK (*R. S. E.*).—What says "F.?" "Nature never gave Vines bark that should be taken off by the hand of man; it was given them for a wise purpose, and, therefore, should not be removed again." Now this is neither so philosophical, nor even so reverential, as appears at first blush. Suppose we can admit, with "F." that it was given for a wise purpose, and removed for one equally wise—where is "F.'s" philosophy? It so happens, that our gracious Creator has not tied our hands in the use of material things very tight, or we had not been permitted even to prune away branches! But "F." should distinguish between a live bark and a dead bark. In our plan we take no living organs from the tree: only one crime we commit—we take away a very good non-conductor of heat, one which even in its decay doubtless subserves a very useful end. A tree with coarse dead bark on will neither become so rapidly heated nor cooled as a bare and polished one. So far so good. But we "give a sprat to catch a herring." We can, *in-doors*, manage all about these conducting powers easier than we can manage mealy bugs, the concealed spores of destructive fungi, &c. And this, as we conceive, is a justification of the practice, which, however, is established beyond all cavil, by the best gardeners in the kingdom. Prune your *peach-trees* any time from now to the end of January; get them nailed also, providing you can hang canvass or boughs over them directly. Like the bees, they do not require to be awakened in mid-winter.

PRUNING PEACHES AND APRICOTS (*H. M. S.*).—Prune your Peaches, but rather leave your Apricots till the first week of February. You cannot well distinguish the blossom-eyes on the young wood, or even the spurs. Look at an answer to "R. S. E."

VINE BORDERS (*A Country Gentleman*).—If your Vines have been unluckily concreted on the surface of the border—a notion unworthy of the age—we say, pull it all off, and apply a compost, in a slight fermenting state, composed thus—fibrous, free loam, one-part; lime-fubbish, one-part; leaf-soil, one-part; and manure one-part; well-blended. If you are "well-drained below," and your texture of soil right, pray do not take them up.

LONDON: Printed by HARRY WOOLDRIDGE, Winchester High-street, in the Parish of Saint Mary Kalendar; and Published by WILLIAM SOMERVILLE ORR, at the Office, No. 2, Amen Corner, in the Parish of Christ Church, City of London.—December 9th, 1852.

WEEKLY CALENDAR.

M D	W D	DECEMBER 16-22, 1852.	WEATHER NEAR LONDON IN 1851.				Sun Rises.	Sun Sets.	Moon R. & S.	Moon's Age.	Clock aft. Sun.	Day of Year.	
			Barometer.	Thermo.	Wind.	Rain in In.							
16	TH	Cambridge Term ends.	30.365	— 30.336	43—39	S.W.	—	3 a. 8	49 a. 3	9 56	5	3 54	351
17	F	Oxford Term ends.	30.301	— 30.232	44—33	S.	—	4	49	11 8	6	3 26	352
18	S	Eriogaster Populi found.	30.185	— 30.136	45—34	S.	—	5	50	morn.	7	2 55	353
19	SUN	4 SUNDAY IN ADVENT.	30.118	— 29.995	52—43	S.	01	5	50	0 16	8	2 25	354
20	M	Sun's declination 23° 27' s	30.087	— 29.969	53—46	S.W.	02	6	50	1 23	9	1 55	355
21	TU	ST. THOMAS.	29.760	— 29.564	49—38	S.	15	6	51	2 30	10	1 25	356
22	W	Black Duck comes.	29.832	— 29.543	46—35	E.	31	7	51	3 37	11	0 55	357

METEOLOGY OF THE WEEK.—At Chiswick, from observations during the last twenty-five years, the average highest and lowest temperatures of these days are 45.2° and 35.2° respectively. The greatest heat, 58°, occurred on the 16th in 1849; and the lowest cold, 14°, on the 16th in 1848. During the period 92 days were fine, and on 83 rain fell.

BRITISH WILD FLOWERS.

POPPY-WORTS.—PAPAVERACEÆ.

CHARACTERS OF THE ORDER.—*Sepals*, two, deciduous. *Petals* below the ovary, either four, or some multiple of that number, inserted in a cross form. *Stamens* below the ovary, either eight, or some multiple of four, generally very numerous, inserted in four parcels, one of which adheres to the base of each petal; anthers two-celled, innate. *Ovarium* solitary; *style* short or none; *stigmata* alternate with the placentæ, two or many; in the latter case star-shaped upon the flat top of the ovarium. *Fruit* one-celled, either a long pod with two placentæ attached to its sides, or capsular with several placentæ. *Seeds* numerous. *Albumen* between flesh and oily. *Embryo* minute, straight, at the base of the albumen, with plano-convex cotyledons.

PAPAVER. POPPY.

GENERIC CHARACTER.—*Calyx* below the ovary, of two egg-shaped, concave, blunt, equal, deciduous leaves. *Petals* four, roundish, crumpled, spreading, large; narrowest at the base; two opposite ones smallest. *Stamens* very numerous, filaments hair-shaped, much shorter than the corolla. *Anthers* terminal, erect, somewhat stalked, oblong, blunt, compressed. *Germen* roundish or oblong, large. *Style* none. *Stigma* round-shield-like, radiated, downy, permanent. *Capsule* egg-shaped or oblong-reversed egg-shaped, leathery, large, of one cell, incompletely separated into a greater or less number of marginal cells, answering to the number of rays in the stigma, between which the capsule bursts by as many valvular openings, under the stigma, which is more or less elevated by the incomplete partitions. *Seeds* kidney-shaped, numerous, minute, dotted, attached to the partitions.

Section 1.—*Poppies with bristly capsules.*

PAPAVER ARGEMONE; Long-prickly-headed Poppy; Wind-rose; Long-headed bastard Wild Poppy.



Description.—It is an annual. *Leaves*, pinnate, and the pinnae opposite to each other, and deeply pinnatifid, the end pinna being three-cleft; upper side nearly smooth, nerves beneath, and the leaf-stalks rough with spreading hairs. *Stem* leafy, about a foot high; this and the flower-stalk clothed with hairs pointing upwards. *Calyx* hairy. *Petals* wedge-shaped, narrow, often jagged, pale coppery-scarlet, with a black spot at the base, a little distant from each other, and falling in a few hours after opening. *Germen* reversed-cone-shaped, with a stigma from four to six rayed. The germen becomes a capsule having as many cells as the stigma has rays. The capsule is purplish, ribbed, and covered, but most thickly at its upper part, with white bristles, which point upwards. *Stamens* about twenty, with purple filaments; the *anthers* suspended by a fine thread from the top of the filaments; *pollen* bluish. *Seeds* blackish.

It is sometimes found with double flowers, but *Papaver maritimum* of Withering is only a starved specimen of this species.

Places where found.—Corn-fields, especially where the soil is sandy or gravelly.

Time of flowering.—June and July.

History.—This plant is found not only in all parts of Europe but in the Levant; but though so common is frequently unnoticed, owing to the speedy dropping off of its petals. *Argemone* is the old Greek name for this plant, and so called because its juice was found to allay the inflammation of the eyes, known by the name of *Argema*. The bruised plant was also recommended to be put upon the black or blue marks caused by any violent blow.

PAPAVER HYBRIDUM: Bound prickly-headed Poppy. Bastard Wild Poppy.

Description.—It is an annual. *Root* small and tapering. *Leaves* doubly pinnatifid, the segments being numerous, narrow, nearly equal, slightly bending back, and each tipped with a bristle; the pinna at the end of the leaf three-cleft; upper side nearly smooth, but the nerves beneath covered with bristles pointing upwards. *Stem* from twelve to eighteen inches high, this, as well as the branches and footstalks, which are channeled, covered with similar bristles. *Calyx* oval, and slightly hairy. *Petals* small, dingy-scarlet, often violet at the base. *Stamens* with purple filaments, and bright blue anthers. *Stigma* from five to eight rayed, and rather raised above the capsule. *Capsule* furrowed lengthwise, and thickly clothed with tawny bristles, pointing upwards.

Places where found.—In sandy and chalky fields; rare.

Time of flowering.—July.

History.—Never was a specific name more misleading than *hybridum* applied to this Poppy, for it is a true and permanent species. Gerarde says, speaking of both the species—"These plants do grow in the corn-fields in Somersetshire, and by the hedges and highways as ye travel from London to Bath. Lobel found it growing in the next field unto a village in Kent, called Southfleet, myself being in his company, of purpose to discover some strange plants not hitherto written of." Its medicinal powers were considered by the old herbalists to be the same as those of the preceding. (*Lindley. Smith. Martyn. Gerarde.*)

MANY of our readers have heard or read of the difference of opinion which exists respecting the true origin of that anomalous production—the purple Laburnum, *Cytisus Adami*. Some believe it to be a cross-bred plant between the common Laburnum and the purple *Cytisus*, while others as firmly assert that it must be the result of artificial treatment, although the facts respecting the process have escaped notice. The question is, therefore, still at issue, no clue having hitherto been discovered to decide it either way. Mr. Adam, in whose nursery, near Vitry, in France, it was originated about the year 1825, believed it to have issued from a blind bud of the purple *Cytisus* inserted in the Laburnum as a stock in the common way, as related in the Annals of the Horticultural Society of Paris in 1830 by M. Poiteau. A deputation from the Society was sent, after Mr. Adam's death, to ascertain if the original plant was really a seedling or a budded plant. But the evidence of this deputation was contrary to that of Mr. Adam's, and in favour of the cross-seedling side of the question.

This gave currency to many wild and extravagant ideas on the continent as to the effect of hybridisation. The old notion, that mules can revert to one of their parents, was strongly urged by some, and this anomalous plant adduced as a strong evidence that mules could change in time to either of their parents. Even the exploded doctrine of superfecundation was revived to account for the origin of such a plant; and to the present time no satisfactory answer can be given as to how, or by what means, the plant first originated, and it is altogether different from those variations called "sports." Our own belief inclines strongly to the artificial mode through the blind bud, because, among other reasons, if it is really a cross-bred plant, it stands alone in its habits among the thousands that have been so produced. Both parents, very nearly in their original characters, are produced simultaneously with the mixture between them; and the seeds of the two parents, thus produced, will come true in their generation without any variation whatever.

These facts of themselves amount almost to a proof that the purple Laburnum is not a cross-bred plant, but had its origin in some way which we have not yet discovered. For these peculiarities are widely different from the effects of hybridising on plants, as far as we have yet discovered them. We have not yet arrived at any conclusion which would indicate a law or rule by which the reversion of a true cross-bred plant to one or either of its parents is provided for; and, after experimenting on this point for very many years, we cannot say that we ever forced a true cross to assume or re-produce either of its parents; and we believe the thing is an actual impossibility in the vegetable kingdom. It is true that many writers on this subject assert, that what they call a mule plant will in time revert to one of its parents; but no one who has dived much into the mysteries of hybridisation can countenance such a doctrine. All that our experiments on the subject have hitherto brought to light is our own total ignorance of any such law. We cannot even, with any degree of

confidence, foretell whether the offspring of any two plants will be fertile or sterile. The most dissimilar species in any genus, if they will cross at all, will be as likely to produce a fertile offspring as not, while two others, to all appearance the nearest in aspect and affinity, will be equally likely to have a sterile offspring. We make use of the words fertile and sterile to get rid of the confusion caused by the different meanings given to the term mule by different writers. Professor Lindley, in his "Theory of Horticulture," limits the use of the word mule to the offspring of two distinct species, whether fertile or not; while he makes "cross-breeding" to cover all the productions between distinct varieties; and if all writers had kept to these definitions we should be at no loss to comprehend their meaning; but Dr. Herbert, late Dean of Manchester, applied the terms hybrid, cross-bred, and mule, indiscriminately, and scouted the idea of placing any limits between species and permanent varieties; while other writers apply the word mule to any cross that is sterile, and writers on cross-breeding in the animal kingdom are just as far at sea in their opinions and terms. An actual impediment to a proper understanding of the language of hybridisation is thus placed in our path, which it would be useful to remove by discarding the word mule altogether, or at least from our popular literature.

On poor, light soil the colour of the flowers of the purple Laburnum is much affected by the nature of the previous season. After a hot, dry summer the flowers are almost all of that dingy colour peculiar to the first variation, for a "sport" it can hardly be called; and after a wet, cold summer the yellow flowers of the Laburnum are in excess. These variations are not so manifest when the tree is growing in rich moist soil till it attains its full size. If we could fathom the law which governs these variations, it might form a step towards the clearing of the mystery which hangs over the real origin of the plant.

Dr. Herbert suggested a very ingenious and probable hypothesis to account for the possible origin of this tree, which can easily be reconciled with the statement given by Mr. Adam, already referred to. Dr. Herbert believed that the shield of the purple *Cytisus* bud might be still alive after the bud itself was destroyed, and that this live portion might unite with the Laburnum stock in the absence of a bud, and that the new wood, or cellular matter, which formed over the wound, between the shield and the stock, might produce an incipient bud, in the absence of a leading bud; and if the new bud was from an intermixed matter formed by the two plants, it could hardly fail of partaking of the two natures—that is, of the Laburnum stock and the purple *Cytisus* bud, which, in reality, it does; and the question is, how are we to proceed in order to obtain similar productions between other allied plants, for we must still adhere to the fact that species can only mix by pollen, or by this kind of union, when they are nearly related to each other. If it is possible to force a bud from two wounds in union with each other, and partaking of the natures

of two different species thus brought together, there can be no doubt about our being able to push this process farther than can be done by means of strange pollen in the usual way; and we think it can be done, for we perfectly concur in Dr. Herbert's view of the question. The well-known fact, that the two natures in the purple Laburnum aspire to separate themselves from the union, and assume their original character, cannot be accounted for on any other principle.

The means which Dr. Herbert suggested for effecting intermediate forms were to bud in the usual way, and, when the union took place to kill the bud, and to prevent the edges from uniting by lacerating the bark till a quantity of cellular matter was formed, from which a bud might be expected to issue, if the growth of the tree was checked in other parts. It is impossible, however, to succeed simply by this process. The question involves the true origin of latent or incipient buds—a question that has never been satisfactorily answered by any one.

We asserted, many years since, in "The Gardeners' Magazine," that if you cut out the buds from a yearling shoot, leaving only the top bud to carry on the branch, the part of the branch thus disbudded was incapable of producing a latent bud afterwards by any kind of manipulation. This assertion was much disputed by some in private correspondence, when Dr. Herbert opened the question in reference to the origin of the purple Laburnum. A new set of experiments were, therefore, set on foot, to prove if Dr. Herbert's suggestion could or could not be effected; these experiments were begun in 1841, and carried on till the end of 1847. The most conclusive of these experiments we shall briefly relate, as the result is, probably, the only stumbling-block in the way of clearing up the mystery which hangs over the origin of the purple Laburnum.

Truncheons of the common Willow are proverbial for the ease with which they root and produce shoots from all parts of their surface when planted or stuck into the ground. The Willow was, therefore, fixed on as the most likely plant to produce incipient buds. In the spring of 1841, cuttings were made from the strongest Willow shoots that could be procured of the former year's growth. They were two feet long, and all the eyes or buds were carefully cut out, except the three top ones, and they were planted in the usual way in rich kitchen-garden soil. In 1843, when these had made two year's growth, some of them were cut below the growing branches, leaving only a bare stump. Now, we should naturally suppose that a Willow shoot of full three year's growth, and with abundance of roots, in good soil, would not refuse to shoot forth buds and twigs from all parts of the bark. Not so, however; for they died away inch by inch, roots and all, without ever offering to produce a single leaf. In 1844, another lot of the same batch were cut, and they died in the same way. After this, the bark of others was lacerated in all directions, to see if buds would issue from the new-formed wood over these wounds, but all to no purpose; and the last two were cut in the spring of

1847, when they were much stouter than a walking-stick, and they died also. Now, these Willow-shoots, although united to other Willows by inarching or budding, could hardly be capable of producing an union-bud—as we suppose the purple Cytisus and Laburnum to have done—seeing that they could not do so on their own roots; at any rate, the inference is rational enough, and can hardly be controverted. How then, it may be asked, can you suppose the shield of a bud of the purple Cytisus could be capable of taking a part with the Laburnum stock to produce the purple Laburnum? We answer—simply, by surmising that the said bud was taken from a *two* or *three-year-old shoot* of the purple Cytisus, which is not at all unlikely, seeing how thin the bark of a younger Cytisus shoot is. Another inference in favour of this view of the question is, that in France they have always been in the habit of leaving more of the young wood attached to the buds in their nursery operations than is generally done in England; and all of us know, that if a bud on a two or three-year-old shoot is destroyed, a quantity of incipient buds will immediately issue from the surrounding parts. The close-spurring of the Grape Vine is founded on a knowledge of this fact or principle. Therefore, we can see no reason why two shoots of mature age, to form incipient buds, may not be made to produce an union-bud, if the parts are at first properly arranged; and we think we can see why union-buds are not produced in our nurseries when the more natural bud fails, leaving the shield alive and in union with the stock. Our invariable practice is to take the buds from one-year-old shoots; and we have seen, by the experiment with the Willow, that if buds on one-year-old shoots are once destroyed, the shoots are not able to furnish others; besides, it may require more than a season or two to ripen the young wood over wounds sufficiently to produce buds; and leaving a portion of the young wood attached to the bud, may have something to do with the time required.

After weighing these considerations, we think the safest way to treat Dr. Herbert's hypothesis will be to inarch two shoots of closely-allied species, not less than three years old; to bring an eye of each shoot directly opposite in the inarched part, to prevent the wound healing over in the vicinity of the buds for the first season; and when the junction of the edges took the following year, to destroy the buds, or the shoots, which may have sprung from them, and to cut away some of the surface-bark from behind the buds, so that if incipient buds were formed at all, they must come from the sides next to the wounded parts; and if the irritation caused by keeping the wound from healing over has forced the young matter from the two shoots to run into each other, and finally to have formed one solid body, there can hardly be any doubt as to the issue of this experiment. Let it first be clearly ascertained that it is possible to produce an union-bud, and then there need be no limits to the application of the process.—D.

COVENT GARDEN.

FOLLOWING up our remarks on the subject which has occupied our attention for the last two or three weeks, we come now to the consideration of *the Pear*. And here we would observe, that there is even greater room for improvement in the selection of its varieties than is necessary in the Apple. Even in the oldest orchards composed of Apples we find many first-rate established varieties; but it is not so as regards the Pear; and the reason is because it is only of late years that we have been made acquainted with that new race of varieties, for which the world is indebted to the genius of Dr. Van Mons. However much our ancestors may have been disposed to extend the cultivation of this as a winter fruit, they could not, for it had not been brought to the same degree of perfection as the Apple, and thus it is that our markets are so badly supplied during the winter months with such a succession of first-rate Pears as they are with Apples. All the Pears which are brought to market in any quantity are of the earlier kinds, and it would amount to an impossibility for any one to go to Covent-garden market during this and the following months and procure this fruit in the same quantity as they could two or three months ago. But still they can do so with the Apple, and what we want, is that they should do so with the same facility with the Pear. While Apples are now being sold, and will continue for the next four or five months to be sold at per bushel, we have Pears offered at per dozen, and per half sieve. Surely, then, this is a subject worth engaging the attention of those who have even a small portion of ground which may be occupied by such a crop.

In the following selection, we have chosen those which may be regarded as peculiarly rich in flavour, and such as would always command the best price in the markets. The late varieties, particularly, would amply remunerate the grower for any outlay he may incur. As before, we shall take them in the order of their ripening, and as the great object with cultivators is to have their produce either very early, or very late, we have studied the two extremes.

1. *Doyenné d'été*.—The earliest Pear which is worth cultivating, but it is very little known in this country. It is not of a large size, being considerably smaller than the *White Doyenné*, but for a Pear which is ripe in July, it is of good size and excellent flavour, being in this latter respect not unlike the old *Jargonelle*.

2. *Citron des Carmes*.—This is an old-fashioned but excellent early summer Pear, and admirably adapted for orchard planting, the tree being a strong and vigorous grower, an early and abundant bearer, and succeeding well even in exposed situations. It ripens in the early part of August.

3. *Williams's Bon Chrétien*.—We have been doubtful whether or not we are doing right in recommending this, the most delightful of Pears, to the notice of our friends. It is a very uncertain bearer, and those who depend upon it for a crop will be subjected to very frequent disappointments. Still, however, as we have before re-

marked, we are only treating now on what may be called economical planting, and, therefore, we venture to include this excellent variety. Most people, now-a-days, know *Williams's Bon Chrétien*, but if there are any who do not, let them by all means procure a tree. The fruit ripens in August, and continues in use during the greater part of September.

4. *Beurré d'Amalis*.—This is a variety which for a few years past has been rather largely imported from the Continent, and has become so great a favourite in Covent-garden, that many of our largest growers have made considerable plantations of it. None know better than the London market-gardeners what to plant, and we can seldom be far wrong in treading closely at their heels. This is a splendid early autumn Pear, of very large size, handsome shape, and delicious flavour. It ripens in September.

5. *Dunmore*.—This is one of those delightful varieties raised by Mr. T. A. Knight. It is of large size, and of a particularly rich flavour. Every orchard and garden should have it. It ripens in September.

6. *Seckel*.—Of all the Pears we know at this season, we know of none to surpass or even to equal the little *Seckel*. It is originally from America, but it succeeds to perfection in this climate. It is remarkably rich in flavour, and when fully ripe seems as if charged with a powerfully aromatic sirupy juice. It ripens in October.

7. *Beurré de Capiaumont*.—This of late years has been very abundant in our markets, and has become deservedly popular. It is well adapted for orchard planting, being a most abundant bearer, and a beautiful, handsome, and excellent fruit. It ripens in October.

8. *Jersey Gratioli*.—This is a particularly fine Pear, and, if we are not mistaken, we spoke in very high terms of it in some of our early reports. By way of climax, we can only say, wherever there is a garden, there should this Pear be. It ripens in October.

9. *Marie Louise*.—There are none of the Belgian Pears which seem to have had such an extended cultivation as the *Marie Louise*. It is now as common in the markets, and on the fruit-stalls, as the old *Swan's Egg* used to be. It is a most delightful and valuable Pear. The tree is extremely hardy, and bears well. It ripens in October, and lasts till the end of November.

10. *Figue de Naples*.—This is a Pear of good size and of the finest quality. It is comparatively little known, but should always find a place in every collection. The flesh is very buttery, fine-grained, and melting, with a particularly rich, sugary, and aromatic flavour. The tree is a most abundant bearer. The fruit ripens in November.

11. *Passe Colmar*.—A most delicious Pear, and certainly one of the richest-flavoured we know when it is met with in perfection. Its flesh is very fine-grained, very juicy, buttery, melting, sugary and vinous, with a rich aromatic flavour. It ripens in November, and continues over December.

12. *Napoléon*.—Dr. Diel said of this Pear, that one may be said to drink, rather than eat it. Its flesh is tender, melting, and juicy, and very richly-flavoured. It

ripens in November, and continues in use during December.

We must now draw our observations to a close for this week, seeing our space for the market report is rapidly diminishing. But as we have not a great deal to communicate, there being few novelties presenting themselves, we must be content with merely making a general statement.

The prices of fruit continue firm, and rather on the rise. APPLES, for kitchen uses, are making as much as from 5s. to 7s. 6d., and 8s. per bushel. They consist chiefly of *Hanwell Souring*, *Winter Pearmain*, *Alfriston*, and a great quantity of nondescript varieties. Among the choice varieties, we observed *Newtown Pippins*, *Ribstons*, *Golden Pearmain*, *Court of Wick*, and *Downton Pippins*. We do not observe many of the common kinds of PEARS; but there are plenty of the finer sorts, such as *Ne Plus Meuris*, *Nelis d'Hiver*, *Passe Colmar*, *Glout Moreceau*, and *Beurée de Rance*. GRAPES are plentiful, the supply from abroad being rather large. These make from 1s. to 2s. per lb. Home-grown Grapes are also pretty plentiful, and make from 2s. 6d. to 5s., and 6s. per lb.

In Vegetables there is the usual abundant supply, and, generally speaking, a good demand. CABBAGES make from 6d. to 1s. per dozen. COLEWORTS, 1s. to 2s. per dozen bunches. CAULIFLOWERS of good quality, 1s. 6d. to 2s. 6d. per dozen. BRUSSELS SPROUTS, 1s. 6d. per half sieve. CARROTS, 2s. 6d. to 5s. per dozen bunches. TURNIPS, 1s. to 1s. 6d. per dozen bunches. ENDIVE, 1s. to 1s. 6d. per score. POTATOES maintain last week's prices, and are rather inclining upwards.

PLANTS AND FLOWERS.—The supply of EVERGREENS increases, and consists of *Lauristinus* full of bloom. *Chinese* and *Siberian Arbor Vitæ*, *Aucuba japonica*, *Tree Box*, *Red Cedars*, and *Common Laurels*. CUT FLOWERS are very plentiful, consisting of *Chrysanthemums*, *Scarlet Geraniums*, *Roses*, *Heliotropes*, *Chinese Primroses*, *Camellias*, *Cinerarias*, and *Fuchsias*.—H.

GOSSIP.

WE are informed, and we think upon good authority, that our observations relative to the *Great Metropolitan Poultry Show* are not justified by the facts. We lose no time, therefore, in stating what has just reached us, namely, that the Exhibition has been instituted by a few gentlemen, and that no gain is to be made of the refreshments. We have also heard that Mr. Gilbert, who was one of the prize takers at Great Yarmouth, is a chief promoter of this Exhibition, and his experience will insure that it is well managed. These explanations, however, do not touch the general principle we advocated, and still advocate, viz., that Poultry Shows should not be established for private gain, and, we think, Mr. Gilbert's own experience will induce him to join us in recommending the principal exhibitors to unite in signing a declaration, and publishing it in the public papers, that they will not exhibit at any place where their birds are required to be exhibited for more

than two days. We have received a very temperate letter on this subject, from "One of the Hitchin Committee," which we will reply to next week.

The continued *wet weather* throughout November, and down to the time when we are writing (Dec. 6th), has been too seriously felt to require in this column any general comment; but we refer to it for the purpose of stating facts demonstrative that the usual exclamations about never remembering such weather are more than usually well founded. At Chiswick, in the twenty-six years extending from 1826 to 1851, both inclusive, the average fall of rain during November has been 2.182 inches, whereas in the November just concluded 6.20 inches of rain fell, or but little less than treble the usual amount! The excess is very great, even if we take the November when most rain occurred in those twenty-six years—namely, that of 1842, for in that month no more than 4.47 inches fell.

Last month we ought to have expressed the genuine regret we felt at the loss science has sustained by the death of *Dr. Gideon Algernon Mantell*; and we take the more blame to ourselves for the omission, because with him has always been associated the memory of his brother, *Mr. Joshua Mantell*, our friend of early days, who cultivated his Dahlias with no small success, attended to the physical needs of his neighbours, and indulged his literary tastes by writing his *Essay on Floriculture*, and editing *Baxter's Agricultural Library*, whilst resident at Newick, near Lewes. He died in 1839, and now, on the 10th of November of the present year, his more distinguished brother has followed him.

"Dr. Mantell was a striking instance of a rise in life amidst great difficulties. He was born in the parish of St. John's sub Easter, at Lewes, where his father was a shoemaker in a small line of business, but of quick parts, and with a readiness of perception, and a strictness of integrity, which rendered him extremely useful to Mr. W. Cooper, the leader of the political party supporting the Whigs.

"Dr. Mantell has well described his father's virtues in some lines on a tablet erected to his memory in St. Michael's church in that town, reverently ending with the wish—

"Oh fain would he, who in these humble lays
Attempts a father's and a good man's praise,
Follow the bright example thou hast given,
And humbly trace thy footsteps up to heaven."

"The family consisted of four sons and two daughters, and it was with great frugality that the sons acquired their education. Dr. Mantell received his first instruction at a dame school in the same lane as his father's house, and here he was so great a favourite that on the old lady's death she left him her little all. From her he went to the school of Mr. Button, in the Cliffe, where a sound and practical commercial education was given by a gentleman whose political sentiments were so accordant with those of Mr. Mantell the father, that he was known to be on the Government black list. The grammar-school at which Evelyn had been educated was not at that time available for a child of Mr. Mantell's political opinions, the twelve boys on the foundation being nominated entirely by the feoffees. On leaving Mr. Button's school, the kindness of Mr. Cooper came to the aid of the young man, who had attracted the notice of his father's friends by the diligence with which he devoted himself to his studies, and by his quickness and general desire to advance himself in knowledge; and the consequence was that he was apprenticed to Mr. James Moore, a surgeon and apothecary of the old school, an amiable and accomplished man, and a bon vivant. Here, again, Gideon Mantell so far conciliated the good opinion of his master, that, after he had "walked the hospitals,"

and, what was then a novelty in country practice, become a licentiate of Apothecaries' Hall, he was taken into partnership with his former master, and commenced a practice in his native town, which he carried on until the year 1835. In the course of that practice he was eminently successful, especially in cases of midwifery, on which branch, and especially on the use of the *ergot of rye*, he contributed several articles to *The Lancet*, in addition to many articles on other branches of medicine. His professional rival was Mr. Thomas Hodson, who was the great friend of Sir Astley Cooper and Mr. Abernethy, whose skill as an operating surgeon was equalled by few, even among the London practitioners, and whose practice in midwifery was as successful as that of Dr. Mantell. Indeed, so great was the skill of both, that it is recorded in *Smith's Philosophy of Health* (p. 149), that in fifteen years, out of 2,410 cases of parturition in the Lewes district at this time, there were only two deaths; and so fixed upon the attention of the poor was this success, that when Dr. Mantell was elected a member of the Linnæan Society, the popular belief was that F.L.S. meant that he had been elected a fellow of the lying-in society, and, as an old lady emphatically added, 'the society never had a better fellow.' It was in the exercise of his profession, also, and with the assistance of his accomplished brother, the late Joshua Mantell, then in his dispensary, that Mr. Mantell saved the life of a woman condemned to death for the murder of her husband by arsenic; Dr. Mantell having distinctly proved that the tests used, and which were said to have shown the presence of this mineral poison, had entirely and chemically failed. This led to his publication, in 1827, of his 'Observations on the Medical Evidence necessary to prove the presence of Arsenic in the Human Body in cases of supposed poisoning by that mineral. Illustrated with cases.' By the exertion of great interest, and solicitation, in addition to these scientific efforts, the woman's pardon was procured, and she still lives in Burwash.

"At Mr. Button's school Dr. Mantell evinced a strong love for the study of natural history, and, upon commencing his practice at Lewes, he stole—for it could be called nothing else—some hours from the very arduous labours of a country profession to the investigation of the 'Organic remains of a Former World,' firstly in the chalk, and next in the Tilgate formations, which were comparatively new ground. He was greatly encouraged in this work by Mr. Davies Gilbert, and he was largely assisted by the zeal and knowledge of Mr. Stewart Warren Lee, who was his most intimate friend and companion in all his early discoveries. He was also a keen follower of antiquity, and he opened many of the tumuli near the town. In this pursuit he was encouraged by the Rev. Mr. Douglas, the author of *Nænia Britannica*, who was Vicar of Preston, near Brighton. Their results were published in the first volume of *Horsfield's History of Sussex*.

"For nine years he devoted himself to the prosecution of his researches into the chalk formation, and in the foundation of the collection now in the British Museum. In May, 1822, he published, by subscription, the result of his labours in the quarto volume, 'The Fossils of the South Downs, or Illustrations of the Geology of Sussex,' the engravings being executed by his wife, to whom he had been married after an attachment formed during his unremitting professional attention to her father, and whose artistic skill would have done credit to a professional engraver. The work was dedicated to a Mr. Davies Gilbert, through whose recommendation Mr. Mantell was elected a F.R.S. in the year 1825.

"In 1824 he contributed to *Horsfield's History of Lewes* 'The Natural History of the District;' and in December, 1826, he published his 'Illustrations of the Geology of Sussex,' with figures and descriptions of the fossils of Tilgate Forest, among which he had found the iguanodon, the megalosaurus, the plesiosaurus, &c., and had made discoveries which will never be dissociated from his name. Indeed it is as a working geologist, as a discoverer, and as a collector, as a man who, in the infancy of the science of geology, placed before the world the means by which others could write a thesis or found a system, that Dr. Mantell's merits were best displayed, and will be honestly acknowledged.

"He received from the Geological Society in 1835 the Wollaston medal and fund, in consideration of his discoveries in fossil comparative anatomy; and in 1849 the Royal Society conferred upon him the royal medal for his memoir on the *Iguanodon* which was printed in the *Philosophical Transactions*.

"Dr. Mantell quitted Lewes in 1835. Among the patrons of merit which Sussex then possessed was the Earl of Egremont. He was a frequent visitor at Dr. Mantell's museum at Lewes, and mainly by his advice, and with a handsome donation of £1000, the residence of Dr. Mantell, together with his museum, was removed in 1835 to Brighton. The same amount of professional success, however, did not follow him from his native town, and, the Earl having died in 1838, and an attempt to keep the treasures in Sussex having failed, Dr. Mantell disposed of his collection to the British Museum for the sum of £5000, and himself removed in 1839 to practise at Clapham; whence he came to Chester-square.

"His professional practice was not increased by these removals, and latterly he had devoted himself more than ever to literature. We append the titles of some of his principal works, referring for others to the *Bibliographia Zoologica et Geologica* of the Ray Society, where the names of sixty-seven books and essays are given.

"*The Wonders of Geology*. 1838. In two volumes 8vo. This work consists of a series of lectures on the principles and facts of the science. It has gone through six editions, and has been translated into German.

"*The Geology of the South-east of England*. 1838. 8vo.

"*The Medals of Creation; or, First Lessons in the Study of Organic Remains*. 1844. Two volumes 8vo. This also has been translated into German.

"*Thoughts on a Pebble; or, a First Lesson in Geology*. Seven editions.

"*Thoughts on Animalcules; or, a Glimpse of the Invisible World revealed by a Microscope*. 1846.

"*A Day's Ramble in and about the ancient Town of Lewes*. 1846. 12mo.

"*A Geological Excursion round the Isle of Wight, and along the adjacent Coast of Dorsetshire*. 8vo.

"*Petrefactions and their Teaching*. 8vo. This was one of the last of the author's works, and was intended as an introduction to the organic remains in the British Museum.

"Dr. Mantell received a pension from the Crown during the last year, and had scarcely lived to derive any benefit from it. His doctor's degree was acquired from an American university. For the last few years he had suffered from a spinal affection, caused by accident, which prevented him from following his pursuits with his former activity.

"As a lecturer, as well as author, Dr. Mantell was eminently successful. His style was fluent, and he possessed the art of attracting his audience by an exhaustless catalogue of wonders. It has even been said that he yielded with reluctance to the revelation of a truth when it dispossessed him of a pretty illustration. It is certain that he depended much upon the arts of popularity, and he usually obtained all the applause for which he aimed.

"The Council of the Clapham Athenæum have publicly recorded their testimony of Dr. Mantell's last scientific efforts in that locality. They remark that 'For a long series of years the lectures delivered by Dr. Mantell in this place have formed one of the chief ornaments and attractions of successive sessions. No one who has enjoyed the advantage of hearing him can ever forget the singular ability, the felicitous illustrations, and the energetic eloquence which characterised all his discourses. He was one of the earliest and most zealous members of this Institution, and the originator of that series of gratuitous lectures on scientific subjects which have been so advantageous and creditable to the parish of Clapham. The members of the Clapham Athenæum will not be unmindful that Dr. Mantell's services were always prompted by an earnest desire to promote intellectual enjoyment and good-will throughout the neighbourhood; nor will they forget that these admirable lectures were generally delivered by him at the cost of much self-denial, under the pressure of severe bodily pain, and that the last public effort of this gifted man was made in the presence of the Society only a few hours before his lamented decease.'"—*Gentleman's Magazine*.

The following is a list of the *Horticultural and Poultry Shows* of which we are at present aware. We shall be obliged by any of our readers sending us additions to the list, and giving the address of the Secretaries.

HORTICULTURAL SHOWS.

SOUTH LONDON (ROYAL), Dec. 16.

POULTRY SHOWS.

BIRMINGHAM AND MIDLAND COUNTIES, 14th, 15th, 16th, and 17th December.

CORNWALL (PENZANCE), January 10th, and 11th. (*Secs.* Rev. W. W. Wingfield, Gulval Vicarage, and E. H. Rodd, Esq.)

HONITON, January 12th. (*Sec.* H. K. Venn.)

PINE-CULTURE: THE HAMILTONIAN SYSTEM.

(Concluded from page 160).

We have now the remaining heads—"Piping, Root-culture, Recipes, Ripening, Soil, Structures, Suckers, Syringing, Temperature, Watering, Ventilation," and then a few wind-up remarks; and we cry mercy of one portion of our readers, to whom this apparent repetition, or rather "summing-up" may be tedious.

PIPING.—For disposition of this in Hamilton's house, we may refer the reader to page 4 of *THE COTTAGE GARDENER*; and as a "Querist" has desired to know the calibre of pipes in that house, we beg to say that they are of five-inch bore, although Mr. H. observes they *might be* of four-inch. It will be seen, that there are two five-inch pipes in each bed for bottom-heat, viz., a flow and return; and that they are made to proceed to, and return from, an iron reservoir or tank at the farthest end; this saves the expense of elbow joints, we suppose, and is more simple. Two five-inch pipes also proceed along the south, and two along the north, turning round the end opposite the boiler; there also are a flow and return on each side, so that the house is fairly surrounded by piping to warm the air.

Now, as in hot weather the air-piping is not required on duty, Mr. H. says, on this head—"The pipes which heat the air of the house can be plugged up at any time, when only bottom-heat is wanted; this is a mode of my own, and simpler and better than valves." Our advice is, where you have any doubts about amount of piping, either call in an old practitioner, a man who is experienced in Pines as well as pipes, or else employ his fee in laying down a little of what you conceive to be piping which might be dispensed with; anything, in fact, but under-heating.

ROOT-CULTURE.—But little is requisite—still some is desirable. Mr. H. says in his book, page 65—"In conclusion I may state, that only when the roots are to be seen in the axils of the leaves, the operation of earthing-up is required; and it is better to earth-up *among* the leaves, than to destroy them before they have performed their destined offices for the plant." It will be seen, also, that in pot-culture, when an attempt is made to cultivate the old stool without planting it out, he prefers stem-culture, the old roots perfectly undisturbed, to repotting. He says—"I then commence earthing-up with the prepared compost, pressing it a little round the trunk of the plant, and allowing it to slope down to the edge of the pot. I am quite convinced of the superiority of earthing-up over that of transplanting into larger pots after the fruit has been cut. I have invariably found the plants to be from two to four months longer in fruiting, and the fruit also to be much inferior in size." We have here, as in a few other places, slightly paraphrased our author, but feel assured of pardon, the principles not being perverted, and, moreover, time gained. To conclude this heading, we may

repeat Mr. H.'s answer to our query, No. 19. *Question.*—How long after planting before they require culture, and what kind? *Answer.*—"All kinds would be better by a little soil on the top once a-year." By this our readers may see that a little up-stem culture, if not absolutely necessary, is particularly desirable; as soon as our beginners perceive, by observation, the natural habits of the Pine, they will be able to modify their practice to meet, not oppose, its own native bent.

RECIPES.—Mr. H., at page 58, very properly remarks, on insects—"I have known many persons, and have frequently heard of others, who, after having tried every method they have known, have at last been obliged to destroy their whole stock of plants in order to get rid of them;" that is to say, the insects which infest the Pine. Happily for beginners in these days, the rule has become the exception, and foul plants are so little known or expected, that even the wary may occasionally be caught napping in making purchases. No man in his senses would think of buying a stock infested with insects of any kind. If, however, such a case should occur, Mr. H. offers a well-tested recipe, which may be found at page 59 of his interesting work. This is for the cotton bug and white scale, two of the Pines' greatest enemies, and Mr. H. affirms, that "with one application every insect was destroyed without doing the slightest injury to the plants." Many recipes are to be heard of for destroying such pests, but we would fain for the present have the Hamiltonian system fairly represented; and, moreover, we have not space, and perhaps our readers have not patience, for digression.

RIPENING.—Little to be observed here. Mr. H., like all other good cultivators, prefers a somewhat drier air, and a previous abstraction of root-moisture, in order to obtain a high degree of flavour.

SOIL.—Let the reader refer to "Composts" in the present papers; this will save repetition.

STRUCTURES.—More will be urged another day as to what modifications of Mr. H.'s plan might be adopted; for the present, we will just observe, that Mr. H. has so far fallen in with views we have pointed out to him as to the span-roof system, as to admit the following:—"I am of your opinion, that span-roofed houses would be better north and south." Now, this has long been with us a favourite opinion; but as misleading an anxious public is not a light matter, we have, during the last three or four years, sought out opportunities of obtaining the opinions of those we deem first-rate practical men on this subject, believing that we were all held in a sort of thrall in the matter. We may here just point to our old and esteemed friend, Mr. Appleby, who has more than once (during practical chat) expressed himself as decidedly of this opinion; and, verily, the ridge and furrow houses all over the country would seem to bear testimony to a desire to seek some relief from the lean-to method; and not only that, but a sort of desire for a morning and evening slope to houses, in preference to a burning mid-day sun, with all the extras of shading, &c.

SUCKERS.—We have before given a detail of the culture of these, with the technical names by which they are known through subsequent culture. It may here be observed, that Mr. H., in strong terms, points to the immense progress they make attached to the old stool, as compared with those deprived of the assistance of the parent plant, by being entirely detached.

SYRINGING.—On this Mr. H. lays much stress. He says, page 42—"My motive for supplying the plant with a sufficiency of water, by syringing over the leaves, is twofold. First, I believe the leaves of the Pine to be very porous, and, therefore, capable of absorbing a great quantity of its food by that process. Thus, I syringe with tepid water. Secondly, By frequently syringing the plants, the surrounding atmosphere is kept in a humid state, the soil is constantly moist on the surface

of the pot, which causes a constant supply of food to descend to the roots from the fresh compost, and although limited, it will prove sufficient for their supply till the fruit is perfected; whereas, by this usual practice of supplying the roots copiously with water, the nutritious fluids are entirely washed out of the pot, &c." Thus it will be seen how it is that Mr. H. so very seldom waters at the root. The frequency of the syringings must in part depend on the weather, and the time of year; in summer, morning and evening; but in winter some caution is necessary—perhaps about three or four times a week. One thing must here be observed. Most good cultivators judge by the axils of the leaves, and make a point not to repeat the syringing until the axils of the leaves are nearly dry. This points at once to the necessity for a lively temperature, as well as motion in the air by ventilation.

TEMPERATURE.—Although we have briefly observed on air-heat before, we must add a little more under this head. Mr. H. says—"The temperature required for succession plants in the winter, is from 55° to 60° at night, and 65° to 75° during the day. In autumn, winter, and spring, if fruit are to be swelled, they will require 60° to 70° at night, and 70° to 80° during the day. In the summer, the maximum, under the effect of strong sunshine, may rise to 90°, and may be allowed to drop as low as 70° by the morning. In very bright sunny weather, the plants in fruit had better be shaded than admit too much air at any time of the day. In order to swell this fruit to a large size no air ought to be given until the thermometer reaches 80° to 85°, which will generally be by nine or half-past in the morning. To keep it down to this, give it the benefit of air until half-past ten, then close the house,—shade the plants, and water them over the leaves; then let them remain until half-past two or three in the afternoon; then unshade, and let them have all the benefit of light and sun, giving a little air, which must remain until half-past four, then close the house, and syringe again over the leaves of the plants, which will keep them moist during the whole of the night."

WATERING.—This is so seldom requisite under the Hamiltonian system that we merely refer to it in its order to keep the eye fixed on the fact. Of course, we mean watering at root by the ordinary water-pot.

VENTILATION.—Although Mr. H. seems to care less about this than most cultivators, it is his diurnal practice, more or less. Nevertheless, we do think that although for profit his plan is superior to any, yet those who aim at the very highest amount of flavour, and a small crown, would do well to go much beyond him in ventilating points. Of the close treatment, it may be safely affirmed, that it has a tendency to produce big crowns, and these certainly detract from the appearance of the fruit on the table. Mr. H. advocates shading occasionally. Now, the question is, whether east and west roofs would not obviate the necessity of this, and thereby save expense and trouble? We recommend those about to enter on Pine-culture to give this a thought, and, in doing so, to bear in mind Sir. J. Paxton's ridge-and-furrow roofs. We beg again to quote our good friend Hamilton in support of this—"I am of your opinion, that span-roofed houses ought to be built with the ends north and south; if they are not, there must be a good deal of shading, otherwise their leaves will be completely drained of their moisture. I speak from experience; they will have holes burned in them occasionally." It has been generally understood that the Pine requires a winter's rest, or, in other words, should be compelled to cease growing for some eight or ten weeks by a low temperature and a dry atmosphere. Mr. H., like most of the good people in the tall-chimney districts, is all for quick return for capital; and although he does not deny that the elabo-

rations at that period are less complete, yet he will not hear of loss of time, believing it—yea, knowing it—possible, by good management, to still push on (although by more tardy steps) the plants to the desired end. We here think, with all deference, that he carries the idea a little too far; but our readers will judge for themselves.

And now for a correction of errors into which we may have fallen. At page 24, an inadvertency occurs which will surely be pardoned, when it is considered that we have had to wade our way through, at least, half-a-score letters, and, in addition, to watch every idea set forth in Mr. H.'s book. One misleading point, which is a kind of ambiguity, stands thus—"The flow and return in each bed are totally unconnected with each other, or with the flow and return round the exterior, &c., &c." Now, what we really meant to express was this—that each bed had a flow and return of its own to provide the bottom or root warmth; and that each side of the house, north and south, was also, in like manner, fitted up for atmospheric heat. It was also stated, at the same page, that "there must be a great preponderance of heat at the boiler end;" this, however, it appears is not the case. We wrote to Mr. H. once more, after his repeated kindnesses, to invite criticisms as to mistakes, and he has at once set the matter right; for it would appear by his description, that his house is entirely surrounded by piping for the atmosphere, and to use his own words, "there is not half-a-degree difference between the ends." Thus: the boiler, we will say A, has a flow and return into the iron pan (which Mr. H. calls his cesspool), B. From this "cesspool," or, rather, iron-pan (which forms the medium of communication between the boiler and the pipes), proceeds along the south cavity, or alley, a flow, and, of course, return-pipe to and from a similar iron-pan, C, in the south-west corner; be it understood, that in this case the boiler is at the east end of the house. In like manner, a flow and return proceeds along the north cavity, or alley, to the same iron-pan; but this piping has to traverse the west end, of course, before it can reach the iron-pan, B. This will, we hope, render all plain; if not, we will try again.

To conclude, let us, on our own part, and also that of our readers, heartily thank Mr. H. for his very great civility in furnishing information. We owe it to a long acquaintance, doubtless; but, knowing the man well, there was a secret assurance that we might presume on his help. To be sure, it would have been much easier to have skimmed his book, and to have sketched an "article" out of it, which, indeed, could not have erred much; it appeared better, however, to have, if not new matter, at least a confirmation of the old, from the fountain head, and this a good feeling of long standing enabled us to obtain. But those who would fain know the minutæ of Pine-growing by his system, must lay by a few pence and buy his little book. An expositor, after all, is not an author; the public lie at the mercy of his views. In that original work, though small, though dressed in rude attire, and, we may add, not enriched by a high style of composition, may be found by the considerate a host of ideas, or the germs of them, carrying every mark of originality, and of a mind determined to test every previous practice by nature's own standard. We need scarcely observe, that in dissipating the idea of a chamber being a necessary adjunct to Pine-culture, he has done the gardening world no small service, for these chambers are expensive things. We do not say that he has been the first to get rid of this superfluity; he may, or may not be so; but if he is not, who is the man?

We have to acknowledge assistance from Mr. D. Davis, also, of Heaton-Lane Foundry, Stockport, who has been in the habit of fitting up Pineries on Hamil-

ton's plan. He has, it appears, a foundry of his own, and casts all his own pipes, guaranteeing any desirable amount of heat during the most severe weather. Mr. H. tells us, that he is highly qualified to give practical instructions in the way of erecting stoves, having had much experience this way. We have no personal knowledge of Mr. Davis, but Mr. H. points to him as one peculiarly eligible to those within his reach. Another hint:—Thomson, Esq., Greenmount Hall, Harpurhuy, near Manchester, has some true Jamaica Pine plants to dispose of; or those that are by some called Montserrat; which are, at all events, the best kind for winter, and by no means the worst in summer; added to which they are not, by any means, second as to cultivation on the Hamiltonian system. R. ERRINGTON.

BULBS.

(Continued from page 162.)

ANTHOLYZA.—The species of *Anizanthus* are now referred to *Antholyza* by common consent, but there is no feature by which they can be distinguished from *Gladiolus*, except the fore-shortening of the front or lower petals, that part being, as the botanist says, *abbreviated*. *Antholyza* being almost united to *Gladiolus*, through this section having the lip abbreviated, it is immaterial whether we join Sweet's *Anizanthus* to *Gladiolus*—their true position—or to *Antholyza*, whose flowers are more *Anizanthus*-like than like *Gladiolus* flowers. I never heard if these two forms of *Antholyza*, or even the *Anizanthus*, could be crossed with some of the nearest *Gladioli*, such as *Watsonias tristis*, and *concolor*.

The whole order of Irids, to which these plants belong, stands much in want of a thorough revision. Meantime, gardeners and amateurs might greatly assist in this reformation by instituting experiments, perhaps not so much for the purpose of increasing popular varieties, as to determine how far they will stand the test with the pollen. Try if *Antholyza Æthiopica*, *cunonia*, or *splendens*, will cross with any wild *Gladiolus*, or with any cross *Gladiolus*, that may have the flowers less regular than usual. Is it possible to cross *Antholyza* with *Watsonia*? Should these experiments fail, try them differently; let the species of *Antholyza* be first crossed with each other; *Watsonia* the same; and then see whether the crosses, or any of them, will unite the two genera, or fall back to *Gladiolus* through some one of its numerous crosses.

Antholyza Æthiopica, *cunonia*, and *splendens*, are the best three in this genus for the flower border, and they hardly ever refuse to grow in any kind of soil that is not too stiff. In pure, fresh peat they will luxuriate and produce abundance of fresh offset bulbs; the same in a deep, light, rich border of sandy loam and very rotten leaf mould; and they are more accommodating than the *Ixias*, for they may be planted any time from the end of September to the end of April. At the Cape, they would seem to be stifled in the hard brown coats and remains of the old bulbs, but that is the best condition for them to drain and throw off the wet from them, and with such natural guards they may remain for many years in a border without being disturbed. I have seen splendid examples of them in pots, in very rich, light soil, but not so good as I have seen them in an open border, being planted six inches deep, and supplied largely with water from the time the flower-stalks appeared.

Antholyza præalta.—This is the next best after the three scarlet ones, and, like them, it grows from two to three feet high. The flowers are orange with a tinge of red.

Antholyza montana.—This is comparatively a small plant for an *Antholyza*, and is much more like one of those curious species of *Gladiolus* one often sees from

the Cape; and when we remember that it was through *Gladiolus tristis*, the oddest thing you ever saw, that Dr. Herbert laid the foundation of the beautiful races of them which we now so much admire, dare we assert what is "looming in the future" of this *montana*?

Antholyza quadrangularis is another anomaly in its way—indeed, it would take a clever botanist to say what it is; and after that a few touches of the pollen might prove that it was no such thing. The flowers are narrower and less shortened in front than those of *cunonia* or *splendens*, and the colour is that faintish yellow which few admire; but the plant is as strong and as easily managed as *cunonia*, or any of the more fashionable *Gladioli*.

BABIANA.—A common observer could not tell a *Babiana* from a *Sparaxis*, nor some of the latter from *Ixias*, and some species of *Ixia* run so close to *Tritonia* that, without knowing the "private mark," no man could know the one from the other. The colour, size, or texture of the seeds is no criterion of generic differences among these *Ixia*-like plants. The insertion of the stamens, here or there, in the flower would carry the same weight with a pollen master. Versatile anthers, smooth or jagged spathes, and other marks of distinction, have been useful enough hitherto as "private marks" for telling present arrangement; but sooner or later the whole must be laid aside, and a reconstruction of *Ixias* be made; therefore, cross all the species as if they were in one genus already,—if they do not mix, that is no sign of a natural difference, and if they do, it will prove useful in two ways—an improvement in the garden varieties, and a check on the labours of the systematist. All the *Babianas* are quite dwarf plants, and more fitted for pot-culture than out-of-doors. They prefer sandy peat when confined in pots, but out in a border they will do without a particle of peat, if the soil is very light. Four inches is deep enough for the bulbs, and if a handful of clean sand is put round half-a-dozen of the little bulbs in a patch, they may remain undisturbed for several years. Whether in pots or in a border, they ought to be planted early in October, and not to receive more than the first watering at potting time until the leaves are well up above the ground; and there is not a plant in the whole order (Irids) that likes to be without a free admission of air during every period of its growth. There is about a score of species in this genus, but their culture being so uniform, I shall not waste space with separate accounts of them. Under *Sparaxis* I shall show a good way of growing a collection of such bulbs in the open air.

BARNARDIA SCILLOIDES.—This is a small, half-hardy bulb from China, with purplish small flowers. I think it was introduced by the Horticultural Society; at any rate, I recollect it as among the earliest plants that Dr. Lindley named on his own account. A figure of it first appeared in the Botanical Register in December, just twenty-six years ago, when I was at Altyre, and the late Lady Gordon Cumming sent for it at once. It did not seem to like pot-culture, and I have not seen or heard much about it these twenty years; but if it is in cultivation it is well worth having, as few bulbs of its small size flower at the same time—the height of summer. A light, sandy soil will suit it best; and if grown in a pot, the bulb ought to be freed from the soil as soon as it rests, and be kept in sand in a dry place; it might be so kept all the winter, and planted early in February.

BEATONIA ATRATA, curvata, and purpurea.—These are small Mexican bulbs, that are very nearly hardy. *Purpurea*, on which the genus was founded by Dr. Herbert, was discovered in Mexico, by Galeoti, growing along with the *Jacobæa Lily*, *Sprekelia formosissima*. All three refuse to grow in peat, and prefer a good, loamy soil, made light with sand; they grow and bloom during

the summer, and require to be kept dry from October till March. I believe the whole stock of them in the country were in Dr. Herbert's collection when it was dispersed, and that they are now very scarce. Naturally they are intermediate between *Tigridia* and *Cypella*, among the Irids. There is another fine *Tigridia*-looking bulb, growing on the top of the mountain San Felipe, in Oaxaca, in Mexico, which is not yet introduced, I believe; but it would repay a diligent search, and the range is not far out of the route from Vera Cruz to the city of Mexico.

BESSERA ELEGANS, *fistulosa*, and *Herbertii*.—These are also small Mexican bulbs, very pretty, and all but hardy. *Fistulosum* was figured in the Botanical Register, some twenty years since, from a plant flowered by Dr. Herbert, who called the genus *Pharium*; but it was pre-occupied by Schultes, and *Pharium* is now cancelled. *Herbertii* is among the newest of our Mexican bulbs. *Elegans* is the best of the three; the flowers are drooping from the top of the stalk, of a rich orange-crimson, and red stamens. They require exactly the same treatment as the *Beatonia*s; but their affinity is with the *Barnardia* mentioned above, being Lilyworts, of the Squill section.

BLANDFORDIA.—If *Anthericum*s were as gay and varied as *Alströmarias*, *Blandfordias*, and *Bomareas*, they would be equally entitled to a place in our series, for, properly speaking, none of them are bulbs, or corms either; but strangers and all who care little about looking under the surface of things, need not mind the roots when the flowers are gay, and look as if they were produced from real bulbs. *Blandfordias*, with all the aspect of bulbs, are, in reality, only herbaceous plants; their constitution is much stronger and hardier than their outward looks would indicate; indeed, no one who can flower a good Hyacinth three seasons running, need fear trying any of the *Blandfordias* without having more convenience for pot-bulbs than would serve to grow Hyacinths well. *Blandfordias* are from Australia; they belong to the order of Lilies, and to the section of Day Lilies in that order; and the nearest plants to them in that section are the *Tritomas*, from the Cape of Good Hope.

Almost all who like to grow the most showy herbaceous plants know *Tritoma uvaria* and *media*. A young plant of *Tritoma media* would look much like an old-established plant of *Blandfordia*; orange, crimson, and scarlet, mix in the flowers of both; both are increased from side suckers taken off in the spring, and some of the *Blandfordias* seed freely, but *Tritomas* do not seed.

I am not aware of any family of plants that have been yet tried by the cross-breeder, from which better plants for the mixed choice border could be expected than this and *Tritoma*; and, notwithstanding the difference in their flowers, I can see nothing in them to debar their union; get a cross between the old *Blandfordia nobilis* and *Tritoma uvaria*, and if it comes intermediate between the two parents, raising *nobilis* higher in the world, and reducing *uvaria* to the dimensions of an ordinary border-flower, where, among all the herbaceous plants, can such another gem be looked for? There is one thing, and one only, which is proved by cross-breeding, and that is, that if the pollen of a hardy plant, like *Tritoma uvaria*, is dusted on a less hardy one, as *Blandfordia*, the offspring would take after the hardier parent in constitution, therefore *Tritoma* should be the pollen parent. I shall never believe that these may not be crossed together, till all we know of the means of effecting a difficult cross are exhausted.

Blandfordia nobilis.—It was on this species that the genus was founded in 1803. A strong plant of it will throw up a central flower-scape two feet high, bearing a cluster of drooping flowers on the top, the colour being a rich orange-red. It seeds freely, and the seeds

ought to be sown the same day they are gathered; but they will keep for months. Good yellow loam, two-parts, and one-part of turfy-peat, with a little leaf mould and sand, is the right compost for full-grown plants; for younger stages, reverse the proportions of loam and peat, and leave out the leaf mould. But to see this plant in perfection, it ought to be grown out in the open air, in a deep rich border, three summers running, and to be taken up in October, and kept half-dry through the winter, or, what would be far better, to be left in the border, keeping frost and heavy rains from it in winter. All the other species have much of the family appearance; and after you know one of them, you would find little difficulty in recognising any of the genus—orange, crimson, and flame-colour, being the prevailing colours. There is a new and tall species that was little known at the time the genus was printed for THE COTTAGE GARDENERS' DICTIONARY. It was introduced by Mr. Low, of Clapton, with whom I saw it last October, and others of the same genus; the name is *Flamea*, or flame-colour, and they say it grows from three to four feet high, and is easily kept and increased. I linger for opportunity to try a crossing in this beautiful genus.

D. BEATON.

(To be continued.)

ALLOTMENTS.

WHEN duly attending to the higher matters connected with gardening and rural affairs, the interest of the labouring cottager should not be lost sight of. His condition and prospects have secured no little attention from the philanthropist. If schemes failed, the result was not the consequence of a lack of kind wishes. To improve any part of the masses of society there must be, combined with willingness, a thorough acquaintance with the condition, the intelligence, the modes of acting and thinking, of the parties to be benefited; without this the kindest wishes may not unfrequently enhance the very ills they are intended to lessen. Charity itself may be, and often has been, so administered as to militate against self-respect and independence of character. Without a trace of presumption, I have often thought that a committee of moderately intelligent gardeners, with their hearts in the right place, would be able to point out a better redress for many social ills than a more learned conclave of parlour-bred philanthropists, and just because most of us, though at times we take a pen between our horny fingers, have companioned and roughed it with the humblest classes of society in various parts of the country.

With the double flux that is now going on—the influx of gold, and the outflux of emigration—the question of allotments is not likely to occupy the prominent position it did several years ago, when, from several causes, there was a superabundance of labour. Still, as in rural districts good gardens exercise a great influence upon social comfort and moral worth, and as in suburban districts there will be joined, generally, to these advantages, the pleasures of change of scene and of occupation; while in both cases, as many a happy wife could tell, the patch of ground became one of the chief antagonists to the charms of the drink shop—our earnest hope is that these allotments may be vastly increased. Still, when a thing is so good in itself, we ought the more carefully to prevent its being turned into an evil; and having thought and observed much on the working of the system, years ago, I have taken the liberty of alluding to the matter here, to express how thoroughly I agree in the ideas expressed by Mr. Errington in the commencement of his article, page 149, and to hope that those opulent and benevolent individuals who nobly

contemplate extending the allotment system will previously think these matters over. Wishing, however, humbly to support Mr. E.'s opinion, I hope I shall be excused for stating the following deductions:—

1. It is always an advantage that the ground be contiguous to the cottage; next, that it be in a field as near as possible; and if at some distance, that it be approached by a good road.

2. The rent charged, after making allowance for any extras, should be similar to what the farmer pays for the adjoining land.

3. Whatever terms be agreed upon; whatever the conditions as respects regularity of payment; proper and industrious cultivation, and propriety of conduct, necessary to the holding of the allotment; no considerations of previous character, unless there was something very flagrant, should operate as a barrier to obtaining one; for to allow of such a barrier would be tantamount to denying our faith in gardening as an improving influence.

4. It is to the advantage of every labourer to be in regular, constant employment. The allotment or garden should be no decoy from his regular occupation. The extent of his holding should be regulated by what he and his family can accomplish during their own time. Few employers would refuse a man a day at any particular emergency, but this must not be calculated upon as a matter of course. I have met with few who will pay a man regularly and cheerfully in bad weather, who bolts off to his own ground without leave or warning when it is fine.

5. When a surplus of labour abounds in a district, the dividing the land into largish allotments, sufficient to give work for several weeks or months, has been considered a remedy. I am convinced it is merely a temporary palliative. It is based on the supposition, that when not working for the farmer the allotment holder can labour for himself; but unfortunately the farmer and the allotment want that holder's chief services at the same time. Need I speak of the tendency to grumbling, idleness, squatting, and the mutual heart-burnings thus produced?

6. If in rural districts such a superabundance of labour should again exist—as we have painfully witnessed in times gone by—two views as respects allotments present themselves. 1st. If it be conceded that the labourer is remunerated for his work on the allotment—and this, I believe, is generally granted—would not the same labour be worth somewhere about as much to the tenant or the landlord? and if so, might not the labourer be freed from a nondescript position, always an unpleasant one to be in? But, 2ndly. If capital is deficient to pay the labour seeking employment; and yet the superior cultivation of the land would remunerate the labour so employed, why should those able to support themselves for a short time from previous savings, and are willing to labour, not have an allotment that would give them work, not for a few weeks, but during the greater part of the year; a system which in such circumstances would ease the labour market, and prove a barrier to idleness and pauperism? I am aware that such an allottee would imperceptibly become a market-gardener, or a small farmer, thus opening up a great social question. I am, however, merely treating of *allotments* of land; and my object in addressing these words, not to the enemies of allotments, but to their advocates, and as such, the friends of the working classes, is to incite them calmly to investigate, whether between such a small farming allotment, and one that can be cultivated in the over-time of the family, there be, except in special and particular exceptions, any middle course, which, if continuously followed, will benefit, ultimately, either the individual or the community.

7. Some of these special exceptions may consist of jobbers, mechanics, and artisans, who do not expect constant employment at their avocations. The mere change of employment is to them a great advantage. Even here, however, some judgment must be exercised. I have seen men in such circumstances, attending thoroughly to their business, and yet producing specimens of cultivation that few blue aprons could equal. I have seen others trifling on their allotment, neglecting alike their business, and the interests of their family. A smaller or a much larger allotment would to them have been an advantage, just because many men, when much employed on the ground, lose all relish for other work. I have witnessed scores of cases of industrious tradesmen and mechanics, in villages, not more than half employed, their work having gradually lessened through no fault of their own, and yet, from a strong development of the bump of locality, they cannot think of going beyond the sound of the church bell to which they listened in better days. A large allotment to such men would be alike a source of pleasure, comfort, and prosperity.

R. FISH.

GESNERA ZEBRINA.

THE roots of this, after the tops decay, must be kept dry and free from frost. I have often kept them in the pots in which they bloomed, turned over on their sides in the warm end of a common airy greenhouse. A great lover of these plants has directed my attention to a passing notice of their culture lately, for greenhouse decoration in early autumn, by my friend Mr. Beaton, and has put a couple of queries respecting them, which may be generally interesting. 1st, Have you yourself found a similar system to answer? Yes, perfectly so. To obtain large masses of bloom early, either for vases or large pots, it is best to grow single tubers in small pots. Whether checked by being moved to a more cool, airy position, or not, they will show bloom much earlier than when supplied with more feeding room, and may then be turned out of their pots and be packed in the larger vessel. I have thus had fine masses in the beginning of August in a glass-covered veranda. 2nd, Is there not a discrepancy between Mr. Beaton's very easy method, and the great care detailed by you as necessary, some two years ago? I do not think there is. Mr. B. glanced at a system, without going into the minutiae. These little matters, I consider as important as ever, just because fine foliage, with a deep shade of purple, is more admired than even the flower spikes. Hence, care will be saved, when these plants can be started and grown in a hot-house, or forcing-house, where they can either have a slight shade, or be placed from two to three feet from the glass. A frame or pit will enable admirers to have these plants early, though assisted only with fermenting material; but my experience would direct attention to the following points: First, The heating material must be sweet. Second, Even then no steam or vapour should collect around the foliage previously to the sun shining on them. Third, Air should therefore be given night and day. Fourth, The plants should stand at a distance from the glass, or be slightly shaded from bright sunshine. Fifth, The drier the leaves are kept the better. Neglect in these matters will cause you to run the risk of pale, bleached, curled, and blotched foliage; and thus expose you to the loss of at least half the beauty of the plant.

R. FISH.

PERPETUAL CARNATIONS.

SOME of these were exhibited lately at Regent Street. I have understood they were first introduced from the continent by Messrs. Knight and Perry. I do not know how many varieties there are, nor am I certain of the right name of one of them. A friend pre-

sented me with cuttings duly labelled, but the man who planted them out managed to confound them as effectually as if he had shaken the tallies in a lottery bag. These matters some of our friends may give us information upon. Few that I have seen would suit a florist; but they are fine things for the lovers of flowers and sweet scents. They are well named *Perpetual*; but their great charm is that they bloom most abundantly, in autumn, out-of-doors, and in windows and greenhouses in winter, without wanting any forcing. I have seen them grown continuously in pots, with various degrees of success. I wish here merely to detail an outline of the system I adopted, with the results of which I am for the present satisfied. The cuttings were struck in a mild heat in the end of summer; when rooted they were docked to furnish more cuttings, which were struck by the end of autumn. Some of the first-struck were planted out in a border in autumn, and defended with evergreen boughs in winter. The rest, and the second-struck plants, had rough treatment in the pots in winter. All of them, the younger ones being previously stopped, were planted out, about six inches from each other, at the end of March, protected a little by evergreen branches. In May, as I wanted something to fill up a row of Cloves, I took the first-struck ones to do so. In August, September, and October they were noticed by every visitor, as many plants had a dozen of open blooms, with scores of buds to open. In August, the second-struck ones were carefully raised with balls, and potted, some singly in six and eight-inch pots, and others three in a twelve-inch pot. Many of these have been in bloom for some time, and others are in bud. Those in the line of the border, notwithstanding the wet, were still so full of bud and bloom, that I raised and placed a number singly in twelve-inch pots, a fortnight ago, and set them in a cold pit. They seem to feel the change but little. The obtaining such quantities of bloom from young plants, I attribute, first, to the stopping of the growth when young; secondly, to the planting out early in rich mellow soil; and, thirdly, to repeated manure waterings.

R. FISH.

CONIFERÆ.

(Continued from page 165.)

JUNIPERUS SPHERICA (Round-headed J.).—A species from the north of China and the Altai Mountains. Dr. Lindley has named it, and describes it as very beautiful. I have never seen it.

JUNIPERUS SQUAMATA (Scaly J., or Creeping Cedar).—A low growing, trailing shrub, seldom exceeding three feet high; a native of Nepal and the Bhotau Alps. Hardy only in the southern parts of Britain and Ireland.

JUNIPERUS TETRAGONA (Four-angled J.).—Of this species very little is known. It is a native of Mexico, growing on the road-side from Real del Monte to Chico.

JUNIPERUS THURIFERA (Frankincense bearing J.).—A native of Spain; a handsome, upright species, thirty to forty feet high.

JUNIPERUS VIRGINIANA (Virginian Juniper, or Red Cedar).—Native of America, in the States of Maine and Georgia, where it grows to a considerable size, rising to the altitude of from forty to fifty feet. It is very common in the nurseries in this country; and there are some noble specimens at Dropmore, the seat of Lady Grenville, and indeed in most gardens fine plants may be seen of it. The name Red Cedar is given to it because of the beautiful red colour of the inner wood. It is used as a case for black lead, but is not so much esteemed as the Bermuda Cedar for that purpose. The habit is pyramidal, the branches spreading partially horizontally when the tree is old, but in its young state they are upright, but even then not so close as the

J. communis suecica. As it is so plentiful in the nurseries the price is very moderate, even more so than any other Juniper, except the common one. The cause of its abundance arises from the fact that it ripens its seed in this country. The wood being of such a beautiful colour, and so valuable in other respects, combined with the cheapness of young plants, renders it a tree desirable to plant in quantities for the timber. It requires a deep, dry, sandy soil, such as prevails in Sherwood Forest, in Nottinghamshire. It is perfectly hardy.

There are several handsome varieties, though none of them surpass the species in beauty. They are *J. V. humilis*, *J. V. glauca*, *J. V. pendula*, *J. V. aurea variegata*, *J. V. Bedfordiana*, which is beautiful, and *J. V. Chamberlainii*. All these are desirable, and are ornamental objects for the lawn and the Pinetum.

LARIX (The Larch).—To the greater part of our readers this tree is well known, both on account of its good qualities as a timber-tree, and its having been planted in immense quantities in almost every part of England, Ireland, and especially Scotland. Though a native of the Alps of the south of Europe it was almost unknown to our ancestors. The country is indebted to a Duke of Athol for bringing it first into notice. He received two plants, cultivated them in pots, and kept them in a greenhouse till they were too large for the place; they were then planted out in two beds in front of the building, where they grew till they attained the height of seventy or eighty feet. Their perfect hardihood being thus established, seed was saved, and the produce planted out as forest-trees, and this led to their general cultivation as timber-trees. Millions of plants were put in on the Highlands of Scotland, which, on account of their quick growth, soon turned to profit;—this encouraged our landed proprietors to extend its cultivation still further; and it was soon found that the ground on which the Larch grew was greatly improved by the falling off and decomposition of its foliage, the Larch being a deciduous tree, that is, it sheds its leaves annually, which very few of the Pine tribe do.

A drawback has come upon the culture of the Larch, arising from the fact that a disease has attacked them within the last twelve or fourteen years. The tops begin to wither and die, then the side branches, and in four or five years the trees die. This has been particularly observed to have occurred to young trees of four or five years standing, but it is spreading to trees of older and larger growth. How far it will spread is of course unknown, but some measures should be taken to arrest its progress. I should advise every tree the least diseased to be instantly removed, root and branch, and burnt. I would also propose a query to all foresters and owners of Larch plantations, to this effect. What is the cause and probable cure of this serious disease of the Larch in Britain? It would not be amiss to procure seed from the Alps, as it is more than probable that seeds from diseased trees would produce a diseased progeny, or even the same effect would happen if the seeds were gathered from healthy trees growing amongst sickly ones. Then, again, the situation in which to plant this handsome tree should be attended to. If the land does not suit it, it will grow too fast, and become hollow in the centre. This is the case in low, rich land. The proper situation is on the sides of lofty hills, in thin gravelly soils. Though for the first three or four years its progress may be slow, yet it will make rapid progress after that time, and by the annual fall of its foliage enrich the soil under it; thus, feeding itself, as it were, by that means. Another important point is close attention to thinning in time, selecting the most healthy and promising trees to remain. These thinnings make excellent stalks for such flowers as Dahlias and Hollyhocks. The wood of this tree is very durable, hence these stalks will last longer than any

other kind, not even excepting the oak. The genus *Larix* is a small one; the following are the species:—

Larix Europæa (European, or Common Larch), *L. Sibirica* (Siberian L.), *L. Dahurica* (Dahurian L.), *L. Americana*, and *L. Americana pendula* (Weeping Larch), *L. leptolepis* (Slender Scaled L.), from Japan; not quite hardy in the north of Britain. Amongst these the Weeping Larch is a great curiosity, and worthy of a conspicuous situation in the Pinetum, but none of the rest are handsomer in growth, habit, and foliage, than the common Larch. T. APPLEBY.

(To be continued.)

PANSIES RAISED AND GROWN IN ENGLAND.

THIS list, in addition to the one sent me from Berwick, by the Secretary of the Eastern Border Horticultural Society, will form as complete a list as any amateur or dealer need desire.

I am sorry to have to report, that this autumn this favourite flower is suffering much from a disease, something in the same way as the potato. Many collections have almost entirely perished. In particular, I saw that both Mr. Turner and Mr. Bragg, of Slough, had nearly lost all theirs, not one in ten had escaped in the open beds; and that veteran in Pansey culture, Mr. Thomson, of Iver, in Buckinghamshire, informed me, a few days ago, that his stock out-of-doors were quite as bad. If these eminent growers fail, who can expect to escape? The cause and cure of this disease are almost as mysterious as the formidable potato murrain. I would advise every amateur that has a collection to preserve duplicates of his stock in pots, under cold frames, in order to ensure keeping them alive till spring. No doubt this very wet season has aggravated, if not caused this disease, and we may hope, if the anticipated dry frosty weather sets in this month, the complaint may be checked in its progress.

SELS.—FLOWERS WITH THE PETALS OF ONE COLOUR, WITH THE EYE DARK IN LIGHT FLOWERS, AND LIGHT IN DARK FLOWERS.

Adela (Turner); gold-yellow; fine form, and substance extra.

Cowper (Hunt's); canary-yellow, with a dense eye; a late variety. It was shown in fine condition at the Slough Pansey Show last year.

Crystal Palace (Thomson); a clear white, dark centre; fine form.

Commodore (Turner); a large, dark, mulberry-coloured flower, with a rich golden eye; large, fine, and constant.

Fair Maid (Byne's); the best white out; extra size and constant.

Flora Superb (Hooper). Another fine yellow variety, with a dark eye; fine form, and constant.

Goliath (Bragg); very large; dark maroon, yellow eye; fine form.

Hercules (Traicher's); rich mulberry; fine form and substance; size immense.

Ibrahim Pacha (Edmond); extra fine; dark mulberry.

Indian Queen (Thomson); fine dark purple.

King (Jennings); very dark; large and good.

Negro (Schofield); dark maroon; firm substance, fine form.

Nox (Hooper); dark crimson, almost black; good form.

Ondine (Oswald); fine white, with golden eye; a good old variety.

Ophir (Widnall); rich yellow, with dark centre; fine and large; if well grown, very few surpass this.

Pompey (Hale's); very dark maroon; rich texture; fine form and substance, and very smooth on the edges.

Pride of Iver (Thomson); extra fine form; very dark.

Polypheumus (Thomson); fine yellow, dark eye.

Pluto (Thomson); very dark, nearly black; good form.

Royal Purple (Thomson); extra large; fine form.

Royal White (Thomson); medium size; good shape and substance.

Swansdown (Turner); pure white; fine form; eye dark.

Sultan (Lorton); rich dark purple; substance excellent.

Smut (Hooper); shaded bronze, like *Satirist*, but larger; very distinct.

Viola (Thomson); violet-blue, black eye; very attractive, and a quite new colour; very distinct.

YELLOW GROUNDS, WITH MARGINS OF MAROON, CHOCOLATE, RED, BRONZE, PUCE, &c.

Addison (Turner); yellow, with red margin; novel; constant and fine.

Antler (Hooper); yellow, with a broad margin of purple.

Alexis (Gossett); yellow, with bronzy-purple margin; curious and fine; very distinct.

Amelia (Bragg); cream margin, with pale blue; very distinct and beautiful.

Ariel (Youell); yellow, with bronze-red margin.

Brilliant (Byne); yellow, with broad purple belt; fine.

Cæsar (Marsh); yellow, with dark rich maroon margin; fine and constant.

Comet (Thomson); fine show flower; golden-yellow, with crimson-maroon belting.

Crown-all (Thomson); yellow, with purple margin; the finest eye of all Pansies; form good.

Candidate (Thomson); cream, with broad purple margin; a good old variety.

Canopsis (Hooper); gold-yellow, with rich maroon edging.

Clio (Bragg); yellow, with narrow purple edging; very pretty.

Chieftain (Turner); yellow, with bronzy-red margin; very fine shape and substance.

Commander-in-Chief (Hooper); yellow, with red margin.

Diadem (Fellows); golden-yellow, dark maroon top petals, lower petals margined with the same; rich, and fine form.

Dr. Marsh (Marsh); golden-yellow top petals, and belting rich red; unique, and extra fine.

Elegantissima (Thomson); yellow, and bronze-red belting; much superior to *Elegant*.

Euphemia (Turner); straw ground, purple top petals and belting; very fine in early season.

Favourite (Hooper); yellow, and dark maroon belting; extra.

Fearless (Schofield); yellow, and dark maroon margin; fine form, smooth, and great substance; eye very dense.

Great Britain (Parker); yellow, margined with purple; extra fine shape and substance.

Great Western (Hooper); yellow and maroon; large and fine.

Hengist (Turner); yellow and bright red; novel.

Hero (Turner); yellow, and bronzy-red; very stout substance.

Joe Miller; yellow top petals, and belting bronze-red; new and fine; very distinct.

Laertes (Hunt); rich yellow, margined with dark maroon.

Lucidum (Parker); yellow and purple; fine form and substance.

Lord Walsingham (Thomson); yellow and purple margin.

Lord Derby (Thomson); yellow and dark maroon; fine, large, show flower.

Mrs. Bragg (Bragg); golden-yellow, rich mulberry-purple margin; a good old variety.

Monarch (Hale); yellow, with purple margin; extra fine.

Pandora (Hunt); yellow, margined broadly with rich, glossy purple; fine form and texture; and very constant.

Renown (Thomson); fine and large; extra shape and substance; first-rate; yellow and purple.

Rising Sun (Turner); bright yellow top petals, bright bronze-red lower ditto, margined with the same; fine.

Sir John Cathcart (Turner); deep gold-yellow top petals, fiery-bronze lower petals, margined with the same; extra fine substance and form.

Sir Joseph Paxton (Betteredge); yellow top petals, and belting rich dark maroon; fine shape.

Thisbe (Hooper); yellow and novel, bronze margin.

Timour (Bragg); bronze-yellow ground, with purple margin; distinct.

WHITE GROUNDS, WITH MARGINS OF VARIOUS COLOURS.

Albion (Thomson); white, margined with purple; dark eye; large and fine.

Blue Border (Boyd); white, belted with fine blue.

Blue Fringe (Major); white, deep blue edge; rayed; very beautiful.

Beauty (Thomson); white and purple; very fine and unique.

Climax (Bell); white, with broad purple margin; a good old variety.

Criterion (Hooper); white, with deep blue margin.

Eva (Thomson); straw, and rich dark purple margin; surpasses *France Cycote*.

Lady Carrington (Hunt); white, margined with light blue; novel and beautiful.

Lady Fair (Boyd); white, margined with puce.

Miss Caroline (Bouverie, Archer); white, with light blue margin; good.

Marchioness of Bath (Wheeler); white, belted with blue; bold, dense eye; fine form and substance; a good show flower.

National (Turner); white, with a broad, light purple margin; well defined; very smooth, constant, and fine form.

Queen of England (Fellows); white, with blue-purple belt; extra.

Rotunda (Hunt); white, margined with purple; fine form, and constant.

Royal White (Thomson); white, with dark margin; extra fine form and substance.

Sir Robert Peel (Hale); white, with fine purple margin.

Sylvia (Griffin); white, with a delicate, light blue edge; elegantly beautiful.

Venus (Byne); white, with fine blue margin.

T. APPLEBY.

FORCING POTATOES.

WHATEVER be the peculiar fancy of the epicure (and have we not all our fancies?), a dish of young potatoes is sure to find admirers at a season when the old ones (however good) have been sent to table until the appetite seems to long for a change. We all know how delightful it is to see the dish-cover unfold a progeny of young potatoes, instead of the old ones "served-up" in every variety of way that the ingenuity of the kitchen-department could suggest. Young potatoes create a sort of a *furor* for the moment; and the young, aged, and infirm, must all have a taste of the first produce of the season; but it belongs to a higher genius than mine to describe the feelings which this and other productions create on their first introduction; my duties are more

in the back ground, where the operations are at work which furnishes the article at the time wanted. Now, whatever may be the wants or peculiar fancies of certain individuals, we may take it for granted that every one is glad of young potatoes at the earliest possible time; and to accomplish this no time must be lost. The amateur whose means are limited, must look round and see if any vacant space in any of the heated structures is so far at liberty as to allow a few potatoes to be spread thinly over its surface. To exemplify this matter more, we will suppose that plenty of the earliest kinds of potatoes exist in the root-cellar, or other store. Now, in order to accelerate those intended for forcing as an early crop, a few must be put in heat as soon as possible, and afterwards they must be planted out into the hotbed, or other heated apparatus, where they are expected to produce their crop. Now, this preliminary progress on the part of the potato may be of a more homely or economical kind than that which furnishes them the means of supporting a progeny. We all know that a potato placed in a warm situation soon begins to shoot and grow, and we also know, that if these shoots are broken off, others succeed them in, perhaps, greater numbers, but much weaker. This second crop is not always sufficient to exhaust a strong vigorous tuber; but the successive efforts of the parent show too plainly that it must at last yield to such an exhausting process. A potato placed in a warm atmosphere will quickly show signs of life; the vital powers which Nature had intended to remain torpid until she called them forth in spring, are now put in motion by an agent, certainly not equally genial, but quite as warm.

Now a tuber or a bulb differs in many respects from a seed; the latter has stored away in itself the germ of a new plant, which it has likewise the power of preserving for a considerable period, or until it be placed in such a situation as to call its vital powers into action. On the other hand, a tuber, or bulb, is only the accumulated energies of a plant stored away for a limited period, which cannot be prolonged to any great extent, while it may be shortened by the forcing process very considerably; at the same time, some sacrifice, either more or less, must be made in securing this early produce. Now, though there are few things committed to the ground in the shape of seed, or roots, that present a more robust bulky appearance than a good sound potato, yet many eminent horticulturists affirm that it is not always sufficiently strong and well set to be able to support its offspring against the attacks of that disease of which we have seen so much, and know so little: whether this be the case or not, it is not necessary here to inquire; suffice it to say, that the stronger and more vigorous the set, the more likely it is to produce a healthy, good crop, other things being also favourable; it is, therefore, important that those required for forcing purposes be plump, heavy, sound tubers, and not by any means too small; the thoughtful economy which reserves those for seed which are too small for table must be suspended here, and sound, good, useful tubers of a tolerable size employed instead. This is the more necessary in the instance of forcing, because the nourishment and support which the parent set affords to its offspring is more required when in this artificial condition than when the young plant is luxuriating in all the advantages of the spring and early summer atmosphere; this latter differs considerably from anything which we attempt to imitate it in, consequently, a more liberal course must be adopted when anything like success is expected.

To the enthusiastic amateur, we therefore say, select at once a few good useful tubers of fair average size, which place in heat,—if in the light, so much the better; if not, it is not absolutely necessary; lay them

some four or five inches apart each way, on leafy mould, not too much decayed, and cover them up with the same. This covering is required only to prevent that loss the potato is subjected to if the surrounding atmosphere be dry; if moist, it is of less moment. Other substances might do as well as leaf mould, but none lift so well, or rather, nothing adheres so firmly to the roots of plants when it becomes necessary to remove them to another place; and this is important for this preliminary part of the process. Occasional waterings may be necessary, but this will depend on the state of the medium they are placed in, and other things. While this is going on, preparations must be made for their final transplanting into some congenial hotbed or other structure; in a usual way, a bed of leaves, tan, or dung, is appropriated to this crop; and though the early part of the process might as well be performed there as the after part, yet, as it would be difficult to ensure the bed retaining its heat so long as would be wanted for both, I have advised the preparation of the seed tubers to be carried on elsewhere, in order to husband the resources of the principal bed, or rather to delay the making of it until the potatoes are advanced as far as they can, with safety to their removal.

We will, therefore, suppose that the potatoes spoken of have sprouted and emitted roots in all directions, through the body of leaf mould in which they are placed; it is then necessary to prepare the future bed, which, if of fermenting matters, must be tested before the roots are trusted upon it. This is easily done by the means advised so often in the formation of hotbeds; and if the heat seems all right, and the frame and lights put on, a certain amount of good, light, and rather dry mould should be put on. This may remain a day or two until it gets properly warmed, when the potatoes may be removed from their nursery-bed, with as much of the leafy mould adhering to them as will do. These may be planted in rows, about fifteen inches apart for Ash-leaved, and similar short-topped kinds, and proportionably more for the larger-growing kinds; about a foot, or it may be less, between set and set in the rows. There is usually a tendency to crowd plants in a frame. The object of a litter for seed seems not of much consequence; but it is questionable whether this overcrowding be attended with the required benefit or not. The soil in the frame being warm, and the lumps of leafy matter adhering to each tuber, the check cannot be much if due care be taken in the planting, and other things favourable to their growth be attended to. It is almost needless to observe, that a full south exposure must be had for the frame, which must not in any way be shaded by trees or buildings on the sides on which the sun shines; the reverse sides may be as much sheltered as can be, always bearing in mind that the shelter of over-hanging trees is shelter with a vengeance, even should it be on the north side of the object protected by it; but more of this anon. J. ROBSON.

THE VILLAGE FEAST.

By the Authoress of "My Flowers," &c.

THE Word of the Lord declares that he is "blessed" who "standeth not in the way of sinners." Every day we see the truth of this inspired assurance, either in the quiet and prosperous condition of those who keep out of the way of the wicked, or in the punishments and troubles that come down upon those who set at nought the righteous commandments of God. Many a man has kept company with those whose ways were crooked and evil, while his own were decent and respectable; but he has either been obliged to break with them at last, or he has suffered in his own body, or his precious soul, for "walking in the way of sinners," and seen, when it was too late, that the only way of peace and safety is in obeying the commands of the Lord.

The young are especially inclined to be careless about the character of their companions. They are quite content to know and be seen with idle, worthless, young people, if they are not themselves guilty of the follies and vices they walk beside; but, alas! evil, bitter, *eternal*, are the consequences of such careless indifference to sin and sinners; and it behoves all, high and low, old and young, to "stand not in the way of sinners," for a worse end than "sitting in the seat of the scornful" may be their portion—an end that admits of no repentance, and no hope of eternal life. Let my younger readers read, ponder, and lay to heart, the true and terrible story of George Griffiths.

He was a young man of very quiet, inoffensive habits, by no means one of the idle, profligate youths that infest the village, and the persons who employed him spoke well of him. His mother had not been what a mother ought to be in some respects, but she was fondly attached to him. She was the wife of a second husband; but the son of her youth was good to her, and a comfort in the declining years of her life. She had been struck with paralysis also, and had been for some months confined to her cottage in consequence.

There is, in some parishes of England, an annual abomination, called a "Feast." What it takes its rise from I do not know; but it would be a parochial and social blessing if such seasons of riot and drunkenness were discountenanced, and wholly put down; for the only effect of them that is visible is the drinking, disorder, and confusion of the village, and the interruption of work, and squandering of money that invariably takes place at that time. There is generally dancing, penny shows, and such snares laid for the young and giddy; the beer-houses are all as busy as bee-hives; and drinking, finery, and idleness, is the order of the day. Fathers and husbands will spend in one day the week's food of their wretched families, and give up work for that day, and often the next to it, to revel and drink away their senses.

At the last Feast of the parish in which George Griffiths lived, the awful scene took place which I am going to relate. George had been amusing himself with the rest of the community, but in a far more harmless way than many. The beer-houses were full of intoxication, but he was not a drinking character; and although he was amongst the ungodly throng, his head was clear; he had had beer, but was quite sober, and only excited by his high spirits, and the scenes of vain and shocking mirth around him.

One of his companions became so totally intoxicated, that George undertook to see him safely home, as their way was, for some distance, the same. It was late, but the brother of the young drunkard rose and let them in. Instead of going immediately and steadily home, Griffiths was induced to take a glass of spirits at this house, and, in spite of his previous caution, he swallowed a large draught of gin. Then he quitted the house on his way to his mother's cottage.

The next morning, when these two young men got up to go to their work, they found the body of a man lying not far from their door, with his head resting upon some brick-work. It was the almost lifeless body of George Griffiths. Stupified with the gin, he had slipped or stumbled, and his head had come violently down upon a row of bricks or stones, which had caused concussion of the brain, in which helpless state he was found by the very youth whom he had taken home, the evening before, in a state of frightful intoxication. The poor mother's anguish may be imagined, but can scarcely be described, when her son was brought home to her. He lingered through the day and night, and then his soul "returned to God who gave it."

Thus ended the short life of a quiet young man, who stood "in the way of sinners." It is a solemn warning—more solemn than the death of an open sinner, because all see and confess the guilt of open and undisguised sin, and thank God in their hearts that they are not as open sinners are; but they do not see the guilt and peril of quiet lives, when there is no work of grace in the heart. This awful death has set before a whole parish, and all who hear and read it, the startling truth, that they who "stand in the way of sinners" are in peril of everlasting destruction. No man is *quiet* in the sight of God, but he that has sought and found the "kingdom of God and his righteousness;" for "the work of righteousness" only "shall be peace; and the effect of righteousness, quietness and assurance for ever." Quiet lives before men are only hollowness and

deceit; they deceive ourselves as well as others; we say to ourselves "peace, and there is no peace." We are on the road to ruin.

Did George Griffiths suspect, when he undertook to lead his reeling companion safely home, that he was himself to die in a state of intoxication within an hour? Had any one whispered such a thing to him, he would have said, with Hazael, "Is thy servant a dog, that he should do this?" He would have turned away in anger and unbelief. But he was "standing in the way of sinners;" he was in the company of ungodly men; he had no friend by his side to lead him safely on. Satan was at his right hand. The bottomless-pit was open before his feet! Past finding out are the ways of a wise and righteous God! The open sinner still lives, to fill up the measure of wrath, or to "turn from his wickedness and live;" while the quiet sinner was cut off and struck down in a moment; a loud and solemn lesson to all who are leading *quiet* lives, but have, in their hearts, departed from the Lord.

A season of great and glorious rejoicing is at hand. It is a time set *apart* for *spiritual* thankfulness and praise; but it is made a time of feasting and vanity, of revelling and drunkenness, of idle and worldly merriment. Let the young be warned to flee from the evil to come! Let them remember the quiet life and dreadful death of poor George Griffiths. Let them not seek amusement in places where God is not acknowledged, and among persons who regard Him not. Let them remember, that though Jesus Christ died for our sins, He lived as our example, that we might walk in His steps; and, that they who lead quiet lives, and say at stated times "Lord, Lord," are not entered into the kingdom of heaven. Oh, let them beware of those false hopes and bitter delusions! Let them rest in nothing short of conversion of the heart to God, and acceptance of the righteousness of Christ, as our only justification. Let them flee from the company and ways of sinners, as they would from pestilence and roaring lions, and let them *keep the commandments of God*.

Had George Griffiths lived a holy as well as a quiet life, had he known Jesus Christ and Him crucified, he would not have dared or wished to company with those who defied God's law. Then it would have been well with him. But he stood in the way of sinners, and rushed with a brain on fire into the presence of his Maker! Let the young man lay this lesson to his heart; let him serve and worship God, and take warning by the death of poor George Griffiths! There is no repentance in the grave.

VISITS TO SOME OF THE CHIEF POULTRY YARDS OF ENGLAND.—No. 4.

(PENZANCE.)

(Continued from page 130.)

We did injustice to Mr. Blee's poultry, at page 129, in not explaining that the weights there referred to were taken on the 22nd of September. The cockerel No. 1, in the table we published, weighed, at the beginning of November, 11lbs. 6oz.

At Rosevale, in the immediate vicinity of the town, Mr. Bowman, who, with some few others, laid the foundation stone of the "Cornwall Poultry Society," by exhibiting, in the field of the Penzance Agricultural Show, in 1851, certain pens of poultry, which, even then, attracted great attention, has brought together a most valuable collection. But before we enumerate the many beautiful specimens of which he is the owner, it would neither do him justice to pass over the admirable design and arrangement of his fowl-houses; nor would it be fair to those who may be anxious to avail themselves of the practical knowledge which he is at all times ready to communicate. Built of brick, slated, with floors of the same material, they defy the incursions of rats and mice, formidable foes when once they effect a lodgement in such places. Each division has a separate yard, with curiously devised little latticed passages, by which, in some cases, the sleeping-rooms are reached when a direct communication is not attainable. The roosting-places for Cochin-Chinas should always be low, say 20 inches; but many of these birds prefer a board to a perch. But let us now go carefully through his list.

Two Punchard hens, which, with the cock, won a prize at Birmingham, in 1850, first meet our view; the scales being at hand, the weight of one proved nearly 8lbs., heavy for the time of year (September), when the laying season ends, and the moulting draws so heavily on the constitution. Exceeded as this race now often is in point both of colour and size, they will always be valuable for crossing with other Cochin-Chinas, where substance and short legs are desired.

In an adjoining court are the elder white Cochin-Chinas, bred from the stock of the Dean of Worcester; the cock now weighs 9½lbs., and his symmetry and breadth of limb are so striking as induced us to ask Mr. Bowman for his measurements. Below will be found the weight of a son of his, of glossy plumage, and, we think, most perfect form. He is here measured and weighed side by side with his parent.

	COCK OF 1851.	COCKEREL HATCHED FEB. 12TH. 1852.
	inch.	inch.
Length of bill	7 $\frac{2}{3}$	8 $\frac{2}{3}$
Length of neck	7	8
Length from neck to rump....	14½	12
Length of thigh	8	9½
Length of shank	4	4½
Girth over wing, before legs ..	24	23½
Girth over wing, behind legs ..	24	20
Girth of neck, lowest part	12	13
Girth of neck, by head	7	7
Girth, the back part of thigh..	7½	7
Girth of shank	2½	2½
Breadth across wings	9	7½
Weight	9½ lbs.	8½ lbs.

Such weights speak for themselves. Mr. Bowman informs us that he has already disposed of a considerable number of the white chickens of this year, and as several of the pullets were in proportion equal to their brother, no wonder the demand should be great. Two that were weighed before us, though much younger than the cock, weighed respectively 5½lbs. and 5½lbs. An extensive range of ground under some young trees, and surrounded by net, affords a capital run for his pullets. A few evenings since Mr. Bowman was somewhat later than usual in shutting them up for the night, and the passage leading from this enclosure to their home being narrow, they had crowded one on another at its extremity, where the door was shut against them, till they were tier upon tier—three of the lowest were insensible, and one dead; whether any fright, or mere desire of retiring to their nights repose caused the "black hole" catastrophe does not, however, appear. Mr. Bowman possesses a remarkably fine, light-coloured cock of last year, which formed one of the pen, No. 212, at Birmingham, in 1851, purchased by himself and Mr. Blee, and which carried off the 2nd prize for chickens. His carriage is exceedingly upright, the back hackles like golden spangles, drooping richly over the wing, also the arched neck, in our opinion, distinguishes this breed in a remarkable degree.

We also saw some golden Polands—birds, if we mistake not, from the stock of Mr. Vivian, of Swansea, a Birmingham winner. The full globular tuft of the pullets, while that of the cockerel falls backwards on the neck, like the crest of an old helmet, with the clear ground colour of their bodies will, we think, ensure their registration as, A.I.

Nor must we forget among all these treasures some coal black Cochin-China chickens, hardly old enough as yet to display the rich tints assumed by these birds in a mature state, but indicating even at this early age so many good points in figure and proportion, that we doubt not, but that in due time they will realize most fully all that is now hoped of them. This colour, we should remind our readers, is infinitely more rare than either white, buff or partridge. Some of the birds showed a little gold on the hackle but several were coal black.

Many of our readers will be surprised, we imagine, when they are informed of the extent to which the amateur in poultry often extends his transactions. Mr. Bowman, who for four years has devoted so much time to this his favourite pursuit, has most kindly permitted us to mention the following facts, which illustrate very fully the observation just made.

During the present year the amount stands thus:—

Number of eggs sold	374
Ditto hatched at home.....	349
Chickens sold to this time	138
Present stock	117

The eggs were sold at prices varying from 21s. to 36s. per dozen. The chickens at from 21s. to 42s. each, excepting some few objectionable birds which realized from 10s. to 15s. each.

But let it not be supposed that such returns are attainable by every one, who, seeing the prices here realized, rushes into poultry-keeping without that practical knowledge of its various details which has occupied Mr. Bowman's attention for so long a period. If, however, in defiance of our warnings, he is rash enough to do so, the chances of failure and disappointment are indeed great.

Many are of opinion that eggs are greatly injured for sitting by having to travel any considerable distance, and doubtless it would be better to set them without incurring the least risk from being shaken; but the result of the chickens produced from 374 eggs sent away this year by Mr. Bowman, has been highly satisfactory to those who obtained them from him. One curious instance, bearing on this point, was mentioned by him. "Six eggs, of buff Cochín-Chinas, were sent by omnibus to Hayle, thence by steamer to Bristol, on by rail to Oxford, and there forwarded about 25 miles by coach; after so long and so varied a journey as this, six chickens were, nevertheless, produced from the six eggs."

No less than 14 English counties, as well as various places in Scotland and Wales, have received eggs and chickens from Mr. Bowman during the present season. While speaking of eggs, he remarked, that much had been said about their not hatching well this year, but that, in his own case, he considered himself to have been very fortunate with his very early broods—eight nests, of 11 eggs each, having produced 80 chickens, all of which, but two, which were crushed by the hen when a day or two old, lived and did well; but, he added, "I did not do so well later in the season." Besides what has gone into other parts of England from Mr. Bowman's stock, Mr. Blee has also sent away as far north as Halifax, and beyond London in an eastward direction, more than £30 worth of Cochín-China eggs, beside many young birds averaging from 21s. to 30s. each. His correspondents having given him in most instances an account of the chickens hatched from their eggs—he places the average at 8 eggs out of 11.—W.

(To be continued.)

POTATO GROWING.

PERMIT US to offer, for the *public good*, the extract from our Treatise on Potato Culture, hereafter described, which we trust needs but the thirteenth word, *early*, to be strengthened by an additional syllable, *EST*, to make it complete. On the former, much stress should be laid, and a still greater emphasis on the latter, on which all success depends, whether they are cultivated, or planted by our method therein explained, or not. By a strict adherence to this part of our treatise, and especially the identical word above alluded to, no one need fear diseased Potatoes, and we vouch for good results, believing that Potato disease, by the Divine interposition of Almighty God, will yet prove a blessing rather than a curse, inasmuch as the main crops of wheat or barley in double rows, at wide distances, five feet apart, may be combined with Potatoes with perfect success, and after-crops of many descriptions may also be introduced amongst them with equal profit, such as mangold wurtzel, turnips, and most other garden productions, or, where necessary, whole clean fallows may be made; whereas, formerly it was often with difficulty that land, after potatoes, could be got ready, except in a bad condition, and late in the season, for sowing wheat upon.

We cultivate several varieties of the *earliest* dwarf selected kinds, and have none diseased, simply for two reasons, namely, *planting early*, and planting the *earliest* varieties, which ripen their tubers about the time of the summer equinox, or at the end of June, before which time but few fears need be entertained of disease in the Potato, as it has

not hitherto manifested itself before this time, except in a small degree. We have no objection to other kinds of manure being applied besides what is recommended in our pamphlet, nor do we see any reason why *EARLY* Potatoes should not be highly manured, in order to forward their growth before and after they appear above ground, and when devoid of moisture, so often experienced in the month of June, as well as in providing for after-crops. The evil of using manure is confined to late planting, which practice (without arrogance to ourselves) it is found necessary, under present circumstances, to denounce altogether, for, whatever the kinds may be, all are thus attended with bad results.

Some part of our treatise, not hereafter inserted, not being adapted to the present seasons, as we find from experience, requires revising, and is under our immediate attention and correction.

The use of small Potatoes for planting is only recommendable in cases of emergency like the present time, and for those who cannot afford to buy larger ones, and the guidance of the *public good*, we freely subjoin the following communication:—To plant one acre of land with large *earliest* Potatoes, 4 ozs. each, at one yard apart, requires 21½ bushels of per 56 lbs.; present value about £5. To plant it with sets half the size, at the same distance, of course requires 10¾ bushels; value about £3. And to plant it with sets 1 oz. each, of the common size, now in use, at half the distance, viz., half-a-yard apart (ample space), takes about 10 bushels per acre, equal to a quarter-of-a-peck per rod; present value, say £1 10s., of early selected varieties. Experience has taught us, repeatedly, that large sets produce the most lucrative crops; but it is to be regretted that so few persons can now avail themselves of this opportunity.—ABRAHAM HARDY AND SON, *Seedgrowers and Seedsmen, Maldon, Essex.*

An Extract from "Culture of the Potato."

"The first point of importance is the selecting or procuring the best early dwarf kinds, and such as have escaped disease; and, secondly, the time and manner of planting, so as to improve their early habits.

"Any time from September to the end of April may be chosen for planting any kind of Potatoes, provided the weather is mild and dry, the latter being most essential. The land, too, should be in a dry and pulverized state previous to planting, which object should be effected and persisted in, by forking it over and over, as may appear necessary, in dry weather.

"If it is desired to plant previous to March (which we highly recommend), the land being brought into proper tilth, as above prescribed, should be marked into drills four or five inches deep, and twenty-seven inches apart, and the sets or whole potatoes of a middling size, say as large as walnuts, should be planted nine inches distant, with about a teacupful of coal-ashes and soot heaped over each set, to prevent the attacks of intruding insects and frost. Then, with a hoe, cover them with the light dry mould, forming a slight ridge; and lastly, let the whole be completed with the spade or plough, raising the said ridge as high as possible, so that the drill forms exactly the centre. The sets thus secured from wet, frost, and insects, no further care is necessary till the end of March, when the whole may be forked down level, and treated in the ordinary way."

GROWTH OF SHANGHAE FOWLS.

As you have considered the facts contained in my last worthy of insertion in your journal, I beg to continue to report progress. The increase in weight during the fourteen days has been from 9½ oz. to 22 oz. each bird; a greater average than on the previous occasion; but it will be perceived, by the annexed table, that some of the pullets have increased far more than others. None had laid before last week; three then commenced, and laid twelve eggs; which were the three, I am not sure, but think them to have been Nos. 2, 4, and 5. I should add, that three of them were, during six days out of the fourteen, either travelling or shut up and in a pen at the Hitchin poultry show; and I have no doubt they lost weight during those six days, otherwise the total average would have been greater. We will suppose

these pullets to have cost in food 3d. each per week, the total would be for the fortnight, 4s. The total increase in weight is 7½ lbs., which at say 5d. per lb., is 3s. 1½d.; and 12 eggs, at 1½d. each, 1s. 6d.; makes a total of 4s. 7½d.

I do not consider the cost of the food should be set down at more than 2d. per week, but supposing it to be 3d., does not the above account speak in favour of the Cochin-China breed?

I think the result of the present controversy will show that Cochin-China chickens cost to rear more than other breeds, just in proportion to their superior value on account of weight; and that Cochin-China fowls cost less to keep in the proportion of the lesser weight of their eggs. We have, then, in favour of the Cochin-China breed, the size for table use, the beauty and docility of the birds, the richness of the eggs (and if kept on a large scale, the superior value of the feather). In time, I think, a general preference will be shown for the flavour of the flesh of the Cochin-China, and then the slight objection to the colour will vanish. In breeding, it will be desirable to keep the legs as short as possible; and on this score, in a short time, we shall no doubt be perfect.

In my above calculations, I have, of course, not considered the present high prices of good birds, on account of their scarcity; first-rate birds will, no doubt, be always of much value. But our aim should be to show that, for general purposes, the Cochin-China breed decidedly deserves to be the favourite; to show that the cost of their keep is certainly not proportionately greater than that of other breeds; and that in every other respect they excel all other kinds of domestic poultry. I beg to annex the list referred to at the commencement.

	Pullets Hatched.	Weight Nov. 13. lbs. ozs.	Weight Nov. 27. lbs. ozs.	Increase. ozs.
1.	May 15	6 13	7 6½	9½
2.	May 25	5 13½	6 13½	16
3.	May 25	5 10	6 12½	18½
4.	June 13	5 5½	6 11	21½
5.	June 13	5 2½	6 8½	22
6.	June 13	5 1½	5 14	12½
7.	July 27	4 1	4 11½	10½
8.	Aug. 20	3 2½	3 12	9½

—WM. JNO. BEEBY, *Chaldon, near Coulsden, Surrey.*

LONDON FLOWER MARKETS.

How are we to account for the very remarkable fact, that whilst Paris has *five markets*, exclusively devoted to the sale of flowers, London has not *one*? It is true that flowers are sold at Covent Garden, but then they are of secondary consideration, and are so mixed up with fruit and vegetables, that a proper display of them, or suitable accommodation for purchasers, is out of the question. Those who cultivate flowers for sale may justly complain of the want of a proper site for the exhibition of their productions; and the citizens of London may fairly urge their need of a better supply. The love of flowers may be said to be universal; it is an inherent part of our nature, and it is not too much to expect that if a suitable market was established, and placed on a right footing, the sale of flowers would be increased ten-fold. When in London, a short time since, I noticed upon the parlour table of the boarding-house at which I was staying, a vase of flowers, looking very withered and pitiful. On my remarking their appearance to the landlady, "Ah," said she, "we cannot get flowers in London as you do in the country; that nosegay cost me one shilling, and then I had to pay sixpence more by omnibus for going and returning from Covent-Garden to buy it, but it shall be replaced with another to-morrow. I love flowers, and would have a nosegay every other day if I could afford it; as it is, I am obliged to be content with one in a week." Now this good lady represents a numerous class who experience the same want; and there is still a larger, with whom this difficulty of obtaining flowers amounts to a prohibition of their enjoyment; even the opulent would like a better supply. Then we shall soon have the Crystal Palace, with its extensive flower-gardens, which cannot fail to give an additional stimulus to the love of flowers, and an increased desire to possess them. Why should not London, then, have a good flower-market, seeing that there is a demand on the one hand, and an ability to supply it on the other?—S. P., *Rushmere.*

DORKINGS *versus* SHANGHAE.

I AM certain no man can give fowls a fairer trial than I have done for the last ten months with the Dorkings, I having reared nearly one hundred of each sort, and have no other motive in view than to find out which is the best sort to keep. Now, the result of my trial is quite different to the account of "Shanghae Mandarin," as I am able to point out. My Dorkings were an old breed I have had for years; my Cochin-Chinas were from the very best breeds, which I purchased for a very long price, wishing to begin with the best. My first hatch was on the 12th of March, having seven Cochin-China eggs and six Dorking eggs under one hen; the produce was five Cochins and four Dorkings, which were all reared under the same hen. At ten weeks the Dorkings were very nice fowls for the market, but the Cochins had not a feather on them. At fourteen weeks I killed a cockerel of each sort, and weighed them very carefully, the Cochin-China was four ounces the heaviest, but I am certain one Cochin eats quite as much as two Dorkings; then they were both cooked together, and served up on one dish; the Dorking was a fine plump fowl as could be, but the Cochin was ugly, and looked as if the cook had given him a coat of yellow paint before she sent him in—the Dorking was of rich white flesh, and the Cochin very little but bone, and although the Cochin was four ounces more weight, the Dorking was worth two of him as a table fowl. The only point where the Cochin-China can have any preference is their laying; they certainly are better layers, but in no other point can they equal the Dorking; and I am convinced, from my trial of the Cochin-Chinas, that they are not the fowls for a cottager, who must have something that will come sooner to profit than the Cochin-Chinas, if he has no other way to dispose of them but in the market. I am certain he can rear Dorkings for very little more than half the cost he can Cochin-Chinas, and he can take his Dorkings to market at three months old, when he must keep his Cochins five months, unless he takes them without feathers on, when they would look more like young owls than poultry going to a market, for they do certainly look curious things in that downy state in which they remain so long; and any cottager commencing with Cochin-Chinas will very soon find out his mistake, for they are not like other fowls, straying off and finding food for themselves, but standing moping together all day, entirely depending upon what you give them, and that never comes too often, nor in too large a quantity. Now I am not writing what my man has told me, nor what my poultry-woman has told me, but from practice, as no other person has given my fowls one handful of food but myself, and after ten months fair and impartial trial, I have perfectly satisfied myself that the Dorking beats the Cochin-Chinas ten to one.

I would ask "Shanghae Mandarin" what will become of his Cochin-Chinas two years hence, when there is no other way to dispose of them but in the market. What sort of a figure will they cut in a market beside a lot of nice Dorkings at three months old each? they will be laughed at, whilst the Dorkings will find a quick sale, and then will be the time when the cottager will find out which is the best to keep. I am certain my Dorkings are in better condition with what they can find in a farm-yard and a grass-field to stray in, than the Cochin-Chinas are with as good a walk and a very great deal of artificial feeding, and will surpass them in weight; to be certain of which I have just weighed them before I write, making choice of the best of each, and of these I give you the list:—Dorking cockerel, hatched April 1st, 8lbs. 8ozs.; pullet, sister to him, 6lbs. 12ozs.; hen, eighteen months old, 8lbs.; Cochin-China cockerel, hatched March 25th, 8lbs.; pullet, sister to him, 7lbs.; hen, twenty months old, 7lbs. 12ozs. The Dorkings are of my own breed, and the Cochins from a Sturgeon's hen. What will "Shanghae Mandarin" say to this? I have no doubt but some of the Cochin-China breeders will say that they can beat this in weight, and so they may; but not without a very great deal of artificial feeding. Perhaps, too, they may say it is a great weight for the Dorking, and so it is; but they must be of a pure breed, not like some that a well-known exhibitor brought out last year at Birmingham, crossed with the grey game fowl to get the rich colour. He got the colour, but lost the size, which did

not escape the judges' eyes, and satisfied them that they were mongrels.

I think I have said enough to show that the Cochin-Chinas cannot have much preference over the Dorkings, whatever they may have over other fowls; but I hope some of my black Spanish friends will let us hear something of their merits, and not let the Cochin-Chinas carry the laurels which they really do not deserve; and I am certain the time is not far hence when the good old Dorking will again assume the same place as she has done for so many years, viz., second to no fowl as yet known.—FAIRPLAY.

[Our correspondent certainly had not pure short-legged Shanghae's, and he forgets all their good qualities so frequently pointed out in our columns.—ED. C. G.]

HONEY HARVEST IN SOUTH LINCOLNSHIRE.

I TAKE much interest in reading the remarks in *THE COTTAGE GARDENER* by Bee-keepers, and if you think well, I will add my share to the information that has already appeared in your columns, on the past season.

The year has been a very peculiar one with us, in the south of Lincolnshire, and the adjoining county of Rutland; and from thirty apiaries with which I am acquainted, there has been, with one or two exceptions, but little produce. In some of the villages in Rutland the swarming began early. I heard of several swarms on the 9th of May. In one village, which is well wooded, and where the clover was very good, the harvest was considered an average one. The cottager who commenced the year with eight stocks, had nineteen swarms and casts, and obtained 180lbs. of clear honey, after leaving the same number of hives that he began with, well provided for the winter. I have, however, heard of no success equal to this.

My first swarm was on the 5th of June, and this I was obliged to feed considerably. It had 18lbs. 5oz. of contents on the 1st of October. The others did not issue till a fortnight after this; and one, a large one, was hived on the 6th of July, which collected quite as much as that which came off a month earlier. In many instances, I have understood, that the late swarms did better than the early ones; and this, no doubt, was owing to the unfavourable weather in June, at the end of which month many hives were lighter than at the beginning. My hives gained in weight about the middle of May; for I find that the hive that swarmed first collected 1lb. 4oz. on the 17th of that month. There was no real working weather after this till the 3rd of July, when they began to gain immensely. A hive, belonging to a friend of mine, collected 6lbs. 9oz. on that day.

I put one swarm in the place of the parent stock, according to the "Country Curate's" directions. This weighed 5lbs. 7oz. in the evening. I was, however, surprised to find, that scarcely a bee left the parent-hive until the third day after removal; and I should be glad if he would inform me, and one or two others, who take in *THE COTTAGE GARDENER*, and have tried the experiment with a similar result, if this is always the case; as, if so, the swarm is not likely to be much strengthened when it issues late in the day. In one of my hives which did not swarm, I found, at the end of the season, two queens, and a large quantity of brood. I knew the queen to be three years old; and this, therefore, is a proof that they renew their queens when necessary; in which case the natural animosity that exists is suppressed. I saw a more striking instance of this in an observatory hive, where two queens lived amicably together for three or four months, both being fruitful during part of the time; and the old queen expired early in the year.

I should be glad to know if the "Country Curate" has an observatory hive; and, if so, how he contrives to keep it during the winter. I have one in my sitting-room (where I have a fire daily), which is now in a very healthy condition, and well-populated. I helped to swell the population by placing a quantity of brood on the top of the hive in September, which the bees gladly nursed, and as they removed honey which I gave them into the box and added fresh comb, I have allowed it to remain, and it will, no doubt, greatly add to their comfort and prosperity.—OBSERVER.

DISEASES OF POULTRY.

INFLAMMATION OF THE EGG PASSAGE.

[Although the following case terminated fatally, yet, if the judicious treatment had been adopted earlier, the result, probably, would have been different. At all events, even failures act as warnings.]

HAVING at the present time a favourite Cochin hen affected with inflammation of the egg passage (at least as far as I can judge from the symptoms), and being desirous of restoring her, I shall be pleased to know if any better mode of treatment could be recommended than the following.

In the first place I will state, perceiving the hen unusually dull on Saturday morning, led me to examine her with a view of ascertaining the cause, when I found the egg bag much distended; so much so, that I was led to suppose at first she could not pass the egg. I at once put her into a warm bath, immersing her for about ten minutes up to the under part of the wings; after which I made another examination, and finding that instead of the bag containing the egg as I at first supposed, it had become distended and very hard. I then gave her a dose of castor oil, which cleared the bowels freely. At night I administered one grain of calomel, and one-eighth grain of tartar emetic, made into a pill with linseed powder, which, with the warm bath, has been repeated every night. This evening I find the part much softer, and the hen appears rather more cheerful. I intend repeating the pill and warm bath. In your next, I will report again as to my success, or otherwise; in the mean time, I shall be pleased to have some person's opinion who has had more experience in such matters; should the treatment mentioned prove serviceable to others, I shall not regret having communicated it.—A SUBSCRIBER.

[I do not think that any much better mode of treatment could be adopted than that above indicated; it would, however, have been more in accordance with ordinary treatment, if the dose of castor oil had been given after, instead of before the calomel and antimony, as in that case the increased secretions caused by these medicines would have been carried off by the aperient. I should think the warm bath advantageous if given without exciting the hen, and care afterwards taken to keep her very warm.—W. T. TEGETNEIR.]

As the Cochin hen died this afternoon, I considered it would be as well to furnish you with a few more particulars for the guidance of your friend. On Thursday I omitted the bath, and as the bowels were irritated, and secretions less healthy, gave calomel one grain, antim. tart. one-twelfth grain, confection of opium sufficient to form a pill. Yesterday the bowels were less irritated; gave hydr. cum creta three grains, rhubarb three grains, compound powder of cinnamon two grains, formed into a pill with crumbs of bread. This morning perceived that the hen was sinking, and a few more hours would close the scene. A few hours after the hen died. I made a careful examination of her; found the oviduct much inflamed and thickened, and of cartilaginous appearance; the whole of the viscera with that exception was quite healthy. I will add, there was plenty of gravel and a manure heap in the yard, to which the fowl have free access.—A SUBSCRIBER.

[I do not think that anything could have been better than the treatment adopted throughout this case; and had the disease been one of acute recent inflammation, there would have been every probability of a successful termination. The cartilaginous thickening of the oviduct appears to have arisen from long-continued chronic inflammation, which, in an advanced state, I should regard as incurable. It would be interesting to know how long the hen had ceased to lay, as that might afford some clue to the period at which the disease commenced, and also whether she was a great layer. As a hen had been lost previously from the same cause, one might almost imagine that there must be peculiar reason for the disease. May it have been over-stimulating food? or the over production of eggs? or want of rest for the oviduct, from the hen's not being allowed to sit?—W. P. T.]

PROFIT FROM WILD FLOWERS.

A FRIEND of mine, whilst staying for the benefit of his health in the Isle of Wight, met with a poor and thriftless family, consisting of a man, his wife, and three children. Judging that the best way of helping them was to teach them to help themselves, he selected one of the little girls, and instructed her by means of two or three lessons in a superior mode of preparing and exhibiting sea-weeds. The project took; sales of them were easily made, and this new employment soon raised the family from a state of indigence to one of comparative comfort. Now, what can be effected with sea-weeds may be accomplished with wild flowers. There are many poor families who, if they could be put into a method of selecting and arranging bouquets tastefully, might find a ready sale for them. Whether as botanical specimens, or for simple nosegays, wild flowers are not turned to the account they might be; they merit greater notice, and a more extended appropriation.—S. P., *Rushmere*.

TO CORRESPONDENTS.

** We request that no one will write to the departmental writers of THE COTTAGE GARDENER. It gives them unjustifiable trouble and expense. All communications should be addressed "To the Editor of the Cottage Gardener, 2, Amen Corner, Paternoster Row, London."

TO PREVENT A HEN SITTING.—J. N. says—"In reply to 'K.' No. 217, the plan I have adopted lately, has been to confine the fowls wanting to sit under a rip for six or seven days, and feeding them *sotely* with the commonest boiled rice (1½d. per pound I give), with plenty of clean water. This I have invariably found to purge the fowls, and prevent wanting to sit. I named this plan, several months ago, to J. H. Payne, Esq.; perhaps he would tell you how it has answered with his fowls, if he has tried it."

ICE (J. W.).—Thank you; the promise was overlooked altogether. "All the details of the same (ice), up to placing iced things on the table," was volunteered; and when people make hasty promises, they must either fulfil them, or repent at their leisure. If you get up a strong opposition to the introduction of foreign ice, by collecting all our home stock into stacks or icebergs, and thatch them well, we shall tell how the "things" are to be iced and sent to table when the weather turns warmer. The ice keeps well in the Lowestoft and Yarmouths depôts; but no plan is so economical as the icestacks, *alias* icebergs.

NORTH GREENHOUSE (A Dabbler).—The recess between the buildings will do capitally to keep flower-garden plants in during the winter, if you can enclose it with glass, and provide against *damp* and frost. The north-east aspect is as good as any other for plants at rest, if they have sufficient light, dry atmosphere, and exemption from frost. Many of the showy summer plants would do very well in such a place, all the time they would be in bloom; but it could not be made a house for *growing* plants in. A work is preparing relative to "the points" of which you enquire.

FLOWER BASKETS (M. Fermanagh).—We are not sure that we understand your meaning. You say—"I want information about *making*, *arranging*, and *planting* flowers in baskets." But we shall keep your letter, and think the matter over. We have hardly any right to call our neighbour's attempt at flower-basketing stupid. If he is satisfied, that is quite enough. We shall give a few examples of how the things are generally done. The seeds of *Gaura Lyndheimeri* would, indeed, be most desirable; but we fear, now that notice has been taken of the plant, it will be too valuable in the trade to let it out by seeds. Nurserymen tell us that they never find stock enough of any new plant we recommend on our own responsibility.

EDWARDSIA GRANDIFLORA.—N. S. H. says—"A fine specimen, growing on the south wall of the Botanic Garden, Bury St. Edmunds, has produced a number of perfect seeds for the first time, although the tree has been planted upwards of fifteen years. Is this an unusual or rare occurrence in other localities?" It is, indeed, very rare for the *Edwardsia grandiflora* to ripen seeds in England, unless it be on the south coast. We never recollect seeing either it, or *E. microphylla* bearing seeds out-of-doors; but this notice will be sure to cause an inquiry as to how far we are right.

BULBS (S. S. S.).—Yes; oblige us by sending the hardy ones, and the stove bulbs also, and we shall treat of them all as they occur. We shall continue to point out those best adapted for pot-culture, and also selections from those genera having many species. Although these bulbs are called half-hardy, some of them are much more hardy than many of the hardy bulbs. *Amaryllis*, *Brunsvigia*, and *Alstromeria*, furnish examples of kinds much harder than many of the *Narcissus*, and even *Crocus* genera, as you shall see when we come to them. Pray make every suggestion you think of; you are entitled to have them attended to.

CLIANTHUS PUNICEUS (A Constant Reader).—"Should the almost bursting buds of one on a N.E. wall be picked off, or any protection given, and how? It is large, and has survived two winters."—It would be safe practice to cut off all the young recent growth, as well as the "bursting buds," and to cover with a double mat, or some equivalent, after the first frost of six or seven degrees. We have seen a nine-year old plant of it, and as large as a moderate peach-tree, killed outright with 20° of frost, although covered with two folds of mat, and against a south wall.

MIXTURE OF LILIES (Twelvemonth's Subscriber).—We very much

approve of your planting two circular beds with a mixture of *Lilium lancifolium* (red and white) and scarlet Martagon, with *L. longifolium* round the outside. See that the bottom of the bed is dry by good draining; and let *L. longifolium* have a little tan, coal ashes, or leaf mould over it in winter. These bulbs flowering at different seasons is not very objectionable, as their growth and leaves are so similar.

RABBITS (Bob).—We do not know of any separate work on Rabbits.

OAT-STRAW FOR COWS (J. B. H.).—We can state positively that oat-straw does *not* "diminish the milk of cows more than does the straw of either barley or wheat." Cut into chaff, and mixed with sliced mangold, sliced cabbage, or steamed potatoes, it makes an excellent fodder for them.

M. NEES VON ESSENBECK (Queen Mab).—You will have seen a notice of the party to whom you may forward your benevolent contribution.

BOOKS (F. B.).—Loudon's Encyclopædia of Gardening, and The Cottage Gardeners' Dictionary, are quite sufficient for you.

POTATO MURRAIN (A Casual Reader).—You invited our request; your postponement is discreet.

TURNIPS FOR COWS (Amateur).—It is difficult to say how many you should buy for the food of your two cows from this time until the 1st of May; we do not know their size, breed, nor appetite! However, it is a general rule that a cow requires daily in food three per cent. of her weight, so you can calculate how much to give each in addition to the grains and chaff you allow them. We should think 20 lbs. of chaff and grains, mixed in equal proportions, and 15 lbs. of sliced turnips, an ample allowance for a cow.

PEARS ON QUINCE STOCKS (A Constant Reader).—With us the Pears bloom profusely, but so early, that for the most part they are destroyed by the early frosts. By due protection this might be prevented.

TO PREVENT A HEN SITTING.—A Constant Reader says—"I have been recommended, and have tried the plan, with success, of keeping the hen in a separate house, without food, for three days. This, I believe, will always have the desired effect."

VEGETABLE OYSTER (Rev. C. A. L'Oste).—We do not know a plant so called. The roots of Salsafy, properly dressed, by boiling, mashing, forming into cakes, and frying in butter, have the flavour of Oyster patties. The *Pulmonaria maritima* is called "the Oyster Plant," its flavour being unpleasantly resembling that of the Oyster.

UNDER TENANT (J. S. W.).—You must consult some respectable attorney; no one could give an opinion without a personal interview and explanations.

FENCING FOR POULTRY YARD (Quærcus).—Galvanised iron wire is the best, and three feet high enough to keep within it your Shanghaes. Speckled Hamburgs and Bantams will require it to be twice that height. Your poultry-house is good, but we have our roof thatched *inside*, by a thick layer of straw confined by laths close to the slates. Warmth is most needed—you can always ventilate enough.

POINTS IN SHANGHAI FOWLS.—T. A. says—"Having just read Mr. B. P. Brent's observations on Shanghai or Cochinchina fowls with much interest, I must beg to mention that the most striking features in 'Shanghaes' are their great depth of breast, and length and size of thigh (not drumstick); in fact, that they more resemble turkeys than any other fowl yet known in this country. Good breasts and thighs are undoubtedly qualifications of the first importance, as *there* the meats (brown and white) are to be found *both excellent and abundant* in this breed when properly fattened. Colour is no criterion as to the purity of the breed, except that there are no black or pure white *thorough-bred* 'Shanghaes' in England. I quite agree that the dark birds are the finest, and have almost invariably found that the light-coloured birds are the smallest."

BEES: DESTROYING ROYAL CELLS.—Investigator says—"I am much obliged to 'Mary' for the reference to the 'Shilling Bee-book.' I remembered the passage soon after I had written the letter, and wondered I had forgotten it, as I nearly know the little book by memory, and there can scarcely be a practical difficulty which it does not meet. To insure the destruction of *all* the royal cells, it is necessary to take out each comb on its separate bar, for, though usually on the edges of the combs, I found one or two suspended within those narrow passages, near the centre of the combs, which serve as communications through the hive. I followed the directions at pages 17 and 38 of the 'Shilling Bee-book;' and will add a few hints, which may be useful to a novice. In the first place, do not be discouraged by an imaginary difficulty; I know more than one lady who has successfully performed the operation. Place the swarm on the stock's stand, and carry the stock some distance into the shade. Your assistant must blow a puff of smoke between each comb before you detach it from the sides of the hive. Commence at one side, and take up bar after bar; before replacing one, take up the next, till you reach the centre, and then commence from the other side. I cut out ten royal cells, three of which were ceiled over, and the others contained larvae in various stages. The bees were indignant at the frustration of their design, and immediately commenced the reconstruction of royal cells; but the queen obeyed my wishes, and so the cells did not advance."

ERRORS.—C. R. R. says—"There are three very sad mistakes in your notice in THE COTTAGE GARDENER of Dec. 2, in my report of the Country Curate's bee system, no doubt attributable to my horrid writing. In lines 28 and 29 you have it, 'and the bees, about 3 lbs., filled a dinner tumbler of the ordinary size;' this should be, 'and the bees about *three parts filled* a dinner tumbler of the ordinary size.' In line 41 you have it, 'one weighs, empty, 3 lbs., another 7 lbs., the third 9 lbs.;' this should be, 'one weighs, empty, 6 lbs., another 7 lbs., the third 9 lbs.' In line 55 you have it, 'with the cap in;' this should be, 'with the cap on.'"

ERRORS.—At page 187, col. 2, line 22 from the bottom, for "all," read "not;" page 188, col. 3, line 2 from the top, for "one," read "our;" line 15 from the bottom, for "judicious," read "judicial."

LONDON: Printed by HARRY WOOLDRIDGE, Winchester High-street, in the Parish of Saint Mary Kalendar; and Published by WILLIAM SOMEVILLE ORR, at the Office, No. 2, Amen Corner, in the Parish of Christ Church, City of London.—December 16th, 1852.

WEEKLY CALENDAR.

M D	W D	DECEMBER 23—29, 1852.	WEATHER NEAR LONDON IN 1851.				Sun Rises.	Sun Sets.	Moon R. & S.	Moon's Age.	Clock aft. Sun.	Day of Year.
			Barometer.	Thermo.	Wind.	Rain in In.						
23	Th	Orange-breasted Goosander.	30.226—30.063	46—30	N.E.	—	7 a. 8	52 a. 3	4 45	12	0 25	358
24	F	White Nun comes.	30.288—30.261	42—43	S.E.	—	8	52	5 53	13	0 b. 5	359
25	S	CHRISTMAS DAY.	30.357—30.318	41—25	S.W.	—	8	53	6 59	14	0 34	360
26	SUN	1 SUNDAY AFTER CHR. ST. STEPHEN.	30.532—30.439	43—17	E.	01	11	54	rises.	☺	1 4	361
27	M	ST. JOHN EVANGELIST.	30.488—30.349	40—29	S.W.	02	8	55	4 a. 49	16	1 34	362
28	TU	INNOCENTS.	30.427—30.313	42—31	E.	08	9	55	5 52	17	2 3	363
29	W	Velvet Duck comes.	30.493—30.486	40—36	N.E.	—	9	56	7 4	18	2 32	364

METEOROLOGY OF THE WEEK.—At Chiswick, from observations during the last twenty-five years, the average highest and lowest temperatures of these days are 42.6° and 31° respectively. The greatest heat, 58°, occurred on the 25th in 1827; and the lowest cold, 10°, on the 24th in 1830. During the period 113 days were fine, and on 62 rain fell.

BRITISH WILD FLOWERS.

POPPY-WORTS.—PAPAVERACEÆ.

PAPAVER. POPPY.

Section I.—*Poppies with bristly capsules.*

(Continued from page 195.)

PAPAVER NUDICAULE: Naked-stalked prickly-headed Poppy.



Description.—This is a perennial. Roots fibrous, slender, and whitish. Stem none. Root-leaves numerous, on long

stalks, bristly, the lowest being the broadest and shortest, least deeply divided, and into the fewest and broadest segments; milky-green, especially on the under-side. From among these leaves arises usually a single, naked, cylindrical flower-stalk, but sometimes two such stalks, less than a foot high, rather milky-green, clothed with horizontal bristles, and crowned with a single pale yellow flower. Calyx of two oval, concave sepals, clothed with brown hairs; of the four petals, which are roundish, the two inner are rather the smaller. Stamens very numerous, having yellowish filaments, and broadish, flattened and channeled anthers. Germen roundish, greenish, crowned with an eight rayed stigma. Capsule, or seed-vessel, roundish, oblong, and bristly. Seeds black when ripe.

Place where found.—Gathered by Professor Giesecke, of Dublin, among rocky glens in the hills at Achilhead, on the north-west coast of Ireland.

Time of flowering.—June.

History.—Being hitherto found upon only one spot in the British Isles, it must be considered as among the many plants of which it may be questioned whether they are really natives. At all events, it was cultivated here as long ago as 1730, for seeds of it were sent to the Eltham Garden in that year, by J. H. de Sprekelsen, who had it from the province of Argunsky, in Siberia. Its flowers are as sweet-smelling as the Jonquil, emitting their fragrance especially during the cool of the morning and evening. Sir W. Hooker, and Dr. Lindley, have enrolled it in their catalogues of our native plants. Linnæus doubted whether it is not a variety of *Papaver alpinum*, or Alpine prickly-headed Poppy. Being a native in great abundance of the shores and islands of the colder regions of North America, a seed may have floated to the coast of Ireland. (Martyn. Withering. Hooker.)

THE most wonderful and most gratifying botanical discovery since the demonstration of the sexuality and circulation of the sap in plants, is the fact that Wheat, at present known to botanists as *Triticum*, is only the miserable grass, *Egilops ovata*, improved by cultivation. We noticed this discovery very briefly at page 267 of our last volume, and we recur to it now, in consequence of the lecture and exhibition of specimens of the plant in the course of its transformation, at the Meeting of the London Horticultural Society on the 7th instant.

The Society having announced that something would be seen and said on the subject at this Meeting, a larger number of the members were attracted to the meeting than is usual at this season. The cultivators of the science of botany, and of practical gardening, were there also in greater numbers than usual; and no wonder, seeing that this discovery relates to a circumstance most remarkably connected with either of their departments.

No one has ever discovered the native country of Wheat, Barley, Rye, or Oats; yet, if a year ago we had

suggested that these at the beginning of the world were not created as we have them; or even if we had said that these improvements of wild produce are merciful sweeteners and aids to that toil by which man is ordained to eat bread by the sweat of his brow, we should have been suspected of being disciples of the author of "Vestiges of the Creation." Nevertheless, the opinion has been gaining ground for years, that in the vegetable, and even animal life, the types originally created were very much fewer than the forms now existing seemingly in a state of nature.

It was in order to exemplify part of this question, that the Society were this day prepared with proofs to show the successive stages of development of that wiry, small grass, *Egilops ovata*, a native of the South of Europe, from the wild state, to the full-eared Wheat of the Pharaohs of Egypt, or of the farmers of old England; and, as if on purpose to overthrow the idle theory of the return of improved races to the original types if left to nature, we have the discovery by Col. Chesney, of Wheat and Barley on the banks of the Euphrates,

the remains of cultivation from the days of Jonah, while the whole circle of the history of plants does not furnish a single well-authenticated instance of an improved variety or species, either by chance or design, turning back to the original variety or species from which it sprang. Yet the doctrine of reversion, or disimprovement, is an axiom in the creed of some who bear the weightiest names among living physiologists. Our double Daisies, Chrysanthemums, and China Asters, our double Ranunculuses, Larkspurs, Pinks, Cloves, and Carnations; nay, all our cultivated Flowers, Fruits, and culinary Vegetables, have been improved by exactly the same process as that by which M. Fabre converted an insignificant grass, by seeds, in twelve successive generations, into a true Wheat plant, the most important of all the cereals, and that, too, in the face of, and against, the mature evidence of botanical science; for, by common consent, the Wheat was placed in a widely different genus from that of *Ægilops*. It now appears that the two are not, even specifically, distinct, but only in different degrees of development.

One of the forms of this species (*Ægilops*) was observed by M. Fabre to have a tendency to assume a different form and character under particular circumstances, and this tendency, in a more or less degree, is seen in a vast variety of plants under cultivation, but the cause of it is an entire mystery. It is a quality, a power, given to those plants by God—we see and we benefit by the effects—we can discover the means of setting that power in motion which will produce those effects—but we can lift the veil no higher. We can go on, however, tracing those effects, and we can find that when improvement once appears in a form of the species that is barren, we have no farther means of encouraging it to greater development, but we can retain it just as it is, by extension from cuttings, and we call it “a sport.” On the other hand, if the new form is capable of bearing seeds, we know that in the first two or three generations of seedlings, provided they are not affected by foreign pollen, many of them will turn back to the original species, some of them will be only repetitions of the first departure, and a small number will often show a still greater departure from the first species, or type. Here is the point, then, where we want skilful observers, like M. Fabre, to step in and follow out the tendency, by patient industry, to its ultimate limit, or to any stage of it which we think the most deserving.

This is just what M. Fabre has effected with the *Ægilops*; and although the result of his experiments will surprise everyone, there is nothing new in the whole process, nor anything at all which is not familiar to every gardener. The last improvement in the flower of the Dahlia was obtained by the very means which M. Fabre used in producing the Wheat plant from a worthless grass. This, so far from being a disparagement, renders the discovery of universal importance, for it cannot fail to stimulate others, in different countries and climes, to trace out, still further and fully, a law which the Creator of all has stamped on the vegetable kingdom, for the use and gratification of His creatures.

Here let us pause to raise a warning against two errors, one of which is prevalent already. In the first place, let it be remembered that the wild grass has not been changed into wheat by a process like changing wheat into flour, or flour into bread. To entertain such an opinion would be a dangerous and fatal error. So far from such being the case, the end was obtained by merely following out that which is well understood as a law of all organised creatures. Secondly—let it be remembered, that seedlings from a natural sport will revert to the first parent before the nature of the sport is indelibly fixed by successive generations, is a fact which has never been denied. Every grower of seedlings knows this; but it does not support the doctrine of the reversion of seedlings obtained by cross impregnation; the assertion of such reversion is altogether false and groundless. Let a true cross be obtained from parents distinct in species, and then, if their progeny produces seeds even to endless generations, no one of the seedlings will ever appear the exact image of either of the two first parents.

The lecture on the discovery of M. Fabre, before the Horticultural Society, was listened to with intense interest, and it was delivered by the lecturer whilst holding up a beautiful drawing, representing an ear of the plant from every stage of the experiment. Beginning on the left-hand-side of the drawing, an ear of the original grass, *Ægilops ovata*, was represented; the next ear was the sport, which is called *triticoïdes*, that is, wheat-like—but the likeness to wheat is very faint indeed. The first seedling from *triticoïdes*, was the third ear in the drawing; and the fourth ear was from the second generation. Ears two, three, and four, looked very much alike, at the distance where we sat; all we could see was that three was somewhat longer than two, and four longer than three; the fifth ear shewed the attainment of a wide difference. It was said to be like a species which grows wild in Egypt, and round the eastern borders of the Mediterranean, and is called *squarrosa*, or rough-spiked—rough and bristly it certainly was—and so on they went, in a row, ear after ear, up to the true wheat-ear itself.

From the lecture we learned that M. Fabre is a gentleman skilful in many things; that his truthfulness is undoubted; and that his word would be readily accepted by all who know him; that his experiments were not carried on in a corner, but out in the open fields, after the manner of a large farmer; that his own men and his neighbours saw all he did, and helped him to do it; that he began in 1840, and that in the twelfth generation, this last summer, the “Wheat itself stood revealed.”—B. J.

COVENT GARDEN.

If any evidence were required confirmatory of our opinion as to the possibility of an extensive cultivation of the more choice varieties of fruits for the supply of our markets than at present exists, it might have been found on Tuesday last, at the meeting of the Horticul-

tural Society. From various parts of the country there were some very fine specimens of the best late Pears exhibited, and among these some from our excellent coadjutor, Mr. Errington, who, if we mistake not, resides in a district which is not remarkable either for the superiority of its soil or climate; but still he was enabled to compete with those who are more highly favoured. We hope we shall live to see the day when such varieties as *Glout Morceau*, *Passe Colmar*, *Ne Plus Meuris*, and *Beurré de Rance*, will be offered in Covent Garden Market during the winter and spring months, in quantities as great as the *Lammas*, *Williams' Bon Chretien*, and *Bergamots* are during the early autumn. There is no reason why it should not be so, if commercial growers could only be brought to see what their own interest is. The greatest London market-gardeners have long found out the value of such crops, and it is by them that the market and fruiterers are mainly supplied; but the country orchardists are wholly ignorant of, or perfectly easy on the subject. We do hope they will bestir themselves in this matter, and thereby benefit themselves and the public also.

We had not space last week to finish our remarks on the selection of Pears, and consequently resume the subject.

13. *Hacon's Incomparable*.—A very excellent and hardy Pear, which is in use during December and January. It is of good size, and the flesh is buttery and melting, with a rich, sugary, and vinous flavour, and highly perfumed.

14. *Broompark*.—This is one of the finest varieties raised by Mr. Knight. It is particularly rich and highly-flavoured, and the tree is very hardy. It is not as yet in general cultivation, but we can strongly recommend it as one of the very best winter Pears. It ripens in January.

15. *Nelis d'Hiver*.—If we grew only six Pears, this would be one of them. It is certainly one of the richest of all our winter varieties. The tree is not, from its natural habit, adapted for orchard planting, and must, therefore, be grafted standard high on some strong growing sort. The fruit, although of larger size from an espalier than from a standard, is, nevertheless, equally as rich in flavour, and attains as high a degree of perfection when grown on the latter. It ripens in December, and continues in use till February.

16. *Shobden Court*.—This is but very little known; but being very hardy, and succeeding well as a standard, it ought to receive a greater extent of cultivation than it at present has. It is a very first-rate variety, of an exceedingly rich flavour, and is at maturity during the months of January and February.

17. *Ne Plus Meuris*.—This would, in our estimation, be another of six. It is one of the very best late Pears, and is at this season, along with *Nelis d'Hiver*, the most highly esteemed of any in the market. It is very richly flavoured, and is in use from December till March.

18. *Easter Beurré*.—This is a fine, large, and handsome fruit, which was introduced, not very many years ago, by the Horticultural Society, from Belgium. It is

of first-rate quality, fine-grained, buttery, and richly-flavoured. It is in use from January till March.

19. *March Bergamot*.—This is another of those hardy and richly-flavoured varieties, for which we are indebted to the industry of Mr. Knight, the late President of the Horticultural Society, and one which ought to be in all collections. We all know how difficult it is to obtain very late Pears of the best quality, and how few there are which keep till the spring months; it is, therefore, with much gratitude that we hear of anything which will fill the void which is too apt to be felt at this season. We know of none better adapted for this end than the *March Bergamot* and the following variety. This *Bergamot* is a medium sized fruit, of an exceedingly rich flavour, and as it is very hardy, it will be found an excellent variety for general planting. It is in use during March and April.

20. *Beurré de Rance*.—We do not exaggerate when we say that this is, perhaps, the most valuable Pear we have, for it is in use at a season when all others are gone. There are, it is true, some new varieties lately introduced, which purport to be as late, and even later; but before we have given these a fair trial, and have had as much experience of them as we have of *Beurré de Rance*, we must, in the meantime, give this the palm. It is a very rich, melting, and deliciously-flavoured Pear, and is in use from March till May.

We have thus given a list of twenty of the best dessert Pears we consider suitable for the purpose we have been treating of; we shall now, by way of variety, furnish the remaining four, as the best adapted for culinary use.

21. *Vicar of Winkfield*.—A very large and handsome fruit, which, when grown against a wall with a south or west exposure, is melting, and well-flavoured; but when grown as a standard forms one of the finest stewing Pears we know. Its great size and fine-grained flesh are great recommendations to it. It is in use from November till January.

22. *Bellissime d'Hiver*.—Another large, handsome, fine-grained fruit, far superior to the *Catellar*, or any of the old varieties. It is in use from November till April.

23. *Bon Chretien d'Hiver*.—One of the most highly esteemed of the old French dessert Pears among the old gardeners both of this country and the continent. To have it at maturity it requires a wall, even in a good situation; but if grown as a standard, the fruit is admirably adapted for *compôtes*. In cooking it becomes very tender and fine-grained, and its juice becomes a syrup, which contains a perfume and natural sugar, which cannot be communicated artificially. It is in use from December till March.

24. *Franc Réal d'Hiver*.—Another very excellent stewing Pear, which before cooking is coarse and husky, but very juicy and aromatic; but when stewed becomes tender and of a fine bright light purple colour. It is in use from January till March.

We shall conclude our remarks on this subject by just calling the attention of our readers to one or two other fruits, which may be advantageously and profitably planted in such situations; we mean the *Damson* and

Medlar. Of the former, the two varieties which are generally cultivated are the *Common Small Black*, and the *Shropshire* or *Prune Damson*; the latter is the larger. Of *Medlars*, there are also several varieties, but those generally grown are the *Dutch* and *Nottingham*; the former is the larger, but we prefer the latter for flavour.

The Market during the week has begun to assume much of a Christmas aspect; and the traveller might imagine himself traversing some forest on the Norwegian Alps, from the immense quantity of Spruce Firs which are standing about in all directions. These, to form "Christmas-trees" for the amusement of juveniles during the coming holidays, will be in great requisition. There is, generally, an air of gaiety pervading the whole; but as this will be considerably developed during the week that is to come, we shall reserve our review of this part of it for our next report. As our notice of fruits has this week extended considerably longer than we anticipated, we shall leave till next week any observations we would have made on this occasion, particularly as all that would have been worthy of comment will be displayed in tenfold importance during that which is to come.

H.

GOSSIP.

A CORRESPONDENT at Birmingham writes to us as follows, concerning *Garden Scrapers* :—

"You have given drawings and descriptions of garden scrapers, which are in some respects desirable, but expensive. They are expensive, because the making involves employing the blacksmith. I enclose a drawing of a scraper made in one piece of cast iron, which in my opinion has many advantages. In the first place, it is cheaper than any wrought iron article can possibly be; it is very light; is ornamental; fixes with the greatest ease, and remains firm in the same place in my garden (a light soil) as long as I please. I obtained mine (and I have a good number) from Messrs. Thomas Jones and Sons, Ironfounders, Bradford-street, Birmingham. They are two shillings each, or eighteen shillings a dozen."

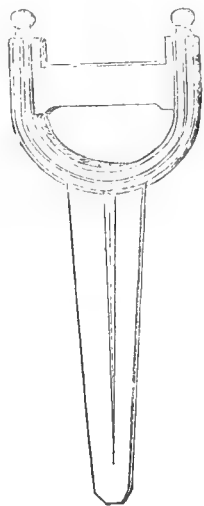

Breadth of scraper to admit the foot, $7\frac{1}{2}$ inches; breadth of the fang penetrating the ground, at the top, $3\frac{1}{2}$ inches; length of the fang 15 inches; entire length from the top of the ornamental knob to the point of the fang, 22 inches.

The following suggestion from the Secretary of a distant Horticultural Society is well worthy of atten-

tion; though we must decline the honour of the judgeship—

"Your useful publication being weekly spread over the whole of Britain, amongst hundreds of floral amateurs, could it not be made the means of bringing them into direct competition, no matter from what part of the country, now that postage is so cheap?"

"The way I would propose is this: Fix upon some flower which could be packed into a small compass, and which could pass cheaply through the post-office. Take, for instance, that popular flower the *Pansy*. Name a day on which the competition is to take place. Supposing that you were to be the judge, then give notice, through means of your Journal, that all flowers must be posted so as to be delivered to you at a certain time; and through the medium of your Journal you could publish the result, together with any remark on new or remarkable flowers which might be submitted for competition. Thus might be brought into direct competition the amateur of all parts of the country. I, myself, who live on the borders of Scotland, nearly 350 miles north of you, might compete with the amateur of Kent or Devonshire. Yorkshire, Cumberland, Norfolk, Essex, and the counties of Wales, might send forth competitors. As for prizes, I think they would not be required, the honour of ranking high would be sufficient."

The following is a list of the *Poultry Shows* of which we are at present aware. We shall be obliged by any of our readers sending us additions to the list, and giving the address of the Secretaries.

CORNWALL (PENZANCE), January 10th, and 11th. (*Secs.* Rev. W. W. Wingfield, Gulval Vicarage, and E. H. Rodd, Esq.)

HONITON, January 12th. (*Sec.* H. K. Venn.)

GREAT METROPOLITAN, January 1st, 3rd, 4th, and 5th.

RENOVATION OF FRUIT-TREES.

(Continued from page 180)

We will now conclude this subject by taking the six classes consecutively—

1st. AGED TREES.—The treatment of trees which are simply wearing-out is simple indeed; they want "more corn and less whip," to use a groom-like phrase. Such trees as we find them, under ordinary treatment, whether in orchards or kitchen-gardens, have been neglected for a length of time as to root-culture, manurings, &c., whilst surrounded, perhaps, by young, gross, and rampant neighbours, which have battened at the expense of these "good old has-beens." But it often fares with fruit-trees as with men: no longer pipe, no longer dance. However, folks are sometimes wrong about the "piping;" we have seen thousands of hardish-worn fruit-trees, in our day, which would have returned a much greater per centage of profit (had they received timely assistance,) than young and rampant trees, which, in the splendid exuberance of their shoots, only flatter to betray. People get impatient too speedily about these wearing trees; still they do well to think of providing successors, for such is the established order of things.

To come to the point: the soil throughout the roots and fibres of old-bearing and wearing-out trees becomes completely exhausted; no man can give it the texture it originally possessed, or add more quality, unless through the medium of surface-dressings, liquid-manure, or a compost of a most coaxing character applied to the extremities of the roots. The two most steady and enduring plans are—surface-dressing, and culture at the extremities, accompanied by a heavier pruning in the branches. Liquid-manure, although

very useful, is more fitting, perhaps, as a summer application, especially at what is termed stoning-time, when fruit are apt to be cast with temporary droughts. For general purposes, use a compost composed of equal parts sound loam and rotten manure, well blended, whether for the extremities or the surface. In laying it on—and it may be six inches in thickness—let every portion of loose soil be scraped away from the surface, even working down a few inches occasionally between the roots. This is done in the rest-season, say November or December; and before applying the dressing, use a few buckets of rich dunghill-drainings over the surface; such cannot be too strong at this season, and when this has settled, apply the casing of soil, and avoid treading over it until settled and dry: the pruning should have been done previously. In adding to the extreme points, of course the operator must throw out a trench at the extremities and fill it up with fresh compost. In pruning aged trees, let most of the small, inferior spray, closed in the interior, be pruned away, maintaining the prime leaders to the last, unless diseased; for from these channels will the most fruitful wood be produced, especially after inferior or choked spray has been removed. In addition to pruning, we would scrub the bark all over with a coarse brush, using some stable-drainings, with plenty of quick-lime blended—thick as mud; indeed, it will be well to thicken it with clay. Now, it is but fair to observe, that we have never used the latter mixture precisely, but we have much faith in it. We were informed, a while ago, by a Cheshire rector, who is “well-up” in everything relating to gardening affairs, that Dr. Darwin, of Shrewsbury, had found the stable sewage the best cleanser of the bark of trees, and that they wonderfully improved in health on its application.

2nd. TREES WORN WITH BEARING.—It might seem at first sight that this, and the former case, are nearly identical; there is, however, sufficient difference to require pointing out. A tree may be worn with bearing before it is seven years old, but it cannot be aged. It may be exhausted in a temporary way, and perfectly capable of rallying in a year or so; but the aged tree can scarcely be said to rally, although it may prove of immense service for many years by generous treatment. There is not occasion, in this case, to have recourse to the trench system at the extreme points; something of speedy action is best, and liquid-manure may be had recourse to, with a rich top-dressing; to this may be added a somewhat sharp amount of pruning, in order to limit the bearing powers of the tree for a season.

3rd. DISEASED TREES.—Another distinct class occasionally; for a tree may be diseased, and yet in neither of the other classes, and may form a complicated case by a union with one or more of them. Now, as a knowledge of the disease is necessary, it becomes eminently essential to ascertain what it is, and its cause. Nearly all our fruit-tree diseases may be thrown into two broad classes, for which we beg to offer the following titles, viz., *Constitutional* and *Adventitious*; each of which may certainly comprise many cases. As instances of the constitutional, may be offered such as *canker, gum, decaying points, corroded bark, &c.*; and, as adventitious matters, *wounds and injuries of any kind, blights, or corruptions* of the system through *insects, frost injuries*, or those arising from a *too low temperature* during the growing season, &c. These may not be all, but they comprise the principal; and it is pretty evident, that the first class are by far the most difficult to overcome; as instance, the *canker* in apples, which no nostrum or recipe has yet been able to conquer, but which mere preventive methods may keep tolerably well at bay. One of the most important proceedings with trees not too old nor too large, is to take care that

the roots are furnished with a pure soil: a loam neither clayey nor sandy.

As this matter of *loam* appears so puzzling to many of our readers, we advise them in all cases of doubt to apply to a first-rate gardener, who, although he may not betake himself to chemical analysis, will yet tell correctly, in a few minutes, whether it be what is known as a general fruit-tree loam. People talk very learnedly about deleterious qualities supposed to exist in this soil or that; but this is, in the main, a mere bugbear. It is, for the most part, principally a matter of texture. Look at our nurserymen, the most knowing of them in such points, how often do they err in their choice of a loam? or, who hears them complaining about its chemical characters? Now, mere garden soil can never equal this loam; it is neither so rich in organic matter, nor so fresh, and it is this freshness, combined with excellency of texture, which renders a pure loam the fittest medium to recover or assist a diseased tree. In all difficult cases, we would plant or surround the tree roots with this loam in its simple state, and if it becomes necessary to impart extra vigour to the tree, let it be by rich surface dressings; and by an occasional application of liquid manure. Of course, in cases of canker, something may be done by scraping the parts clean, and binding in a dressing; we have found a mixture of cow dung, fine loam, and a little lime a good application. The adventitious diseases are too varied to be fully dealt with in a single chapter; and we may just point to the pruning-knife and patience as adjuncts in the case of defects consequent on the attack of insects, which sometimes cause distortions and perversions of the character of the tree. Wounds and injuries may be treated similarly to canker; and those arising from low temperature, by trying to enhance the warmth of the atmosphere by which they are immediately surrounded; to effect this, thin training, the removal of objects which impede the light, and on walls the use of liberal copings, &c.

RAMBLERS—Here is a case for the root-pruner, or the transplanter, we care little which. This much may be said—where any desire exists to renew the volume of the soil, transplanting is best, the tree not being too old or too large; and where there is no fault in the soil, root-pruning will be perfectly eligible. In addition, a liberal branch-pruning, thinning out, and shortening back freely.

SHY KINDS.—There are some kinds of fruits that are by nature shy, or, in other words, which do not grow freely; these, of course, must be treated in a more liberal way. Stimulants may be had recourse to, and surface-dressings every two years will be very useful, and the occasional application of liquid-manure during the growing season. A compost composed of one-part free loam, one-part rich manure, and one-part leaf mould, the two latter three-parts decomposed, and the whole thoroughly mixed, will be found an excellent application in this case. In general, this coating of some three to four inches will become filled with fine fibrous roots, which will infuse an amount of vigour in the tree hitherto unknown.

GROSS YOUNG TREES.—These are to be distinguished from the class “*Ramblers*,” notwithstanding they may be rambling young rogues. It was doubtless inferred by the reader, that the former class signified established trees which show an apparently invincible coarseness. We now speak of that gross fitfulness which is so frequently met with in young trees, not alone through a particular habit inherent, but more commonly through a too generous patron, who perhaps may be a “border maker”—a man of composts; and such men have frequently reminded us of those affectionate animals termed apes, which have been said to hug their young ones to

death in the most affectionate manner. "Save me from my friends; I can manage my enemies."

Well, then, to remove the midden is to get rid of the mushrooms, but it is not always convenient to remove this midden, or, in other words, to change the whole character of a costly border. What then? Why, transplant by all means, adopting instantly our platform mode, or station-making. Those who have not back numbers of THE COTTAGE GARDENER to refer to will do well to get our excellent little *Cottage Gardeners' Dictionary*, which should be in the hands of every one who, not being complete in gardening matters, and with whom time is precious, wants merely five minutes' advice, such as he can rely upon; there he will find these and other matters so highly simplified that "he who runs may read."

And thus we take leave of a subject about which much obscurity has existed in by-gone days; but which the advancing spirit of the age has scattered to the winds, or soon will do. Gardeners, however, must not only have reasons "plentiful as blackberries," but be prepared to offer them in a cheerful way, not as a mere accommodation, but as a duty.

Is it necessary to add, that this time of year is most propitious for laying down plans of renovation, and also for carrying them out in at least their first stages?

R. ERRINGTON.

MEETING OF THE HORTICULTURAL SOCIETY.—DECEMBER 7, 1852.

AFTER the lecture on the discovery of the origin of Wheat, the next object which seemed to command most attention was that about cutting-off the leaves of root-crops before the roots arrived at maturity, without prejudice to the weight of the crop, or to the quality of the root, as far as it has been yet practicable to ascertain; but this subject will be discussed more fully next week.

Among orchids exhibited there was, first, a splendid specimen of the true *Vanda suavis*, from the Messrs. Veitch, of Exeter, bearing about fifty full-blown flowers, showing how different and much better the true species is than the variety of it called *tricolor*, which has usurped its place in some of the best collections round London. Then *Limatodes rosea*, a beautiful new terrestrial species, exhibited in public for the first time. This genus is the nearest in affinity with *Calanthe*: the species exhibited is deciduous, and flowers, after resting, from the bottom of the pseudo-bulbs before the new leaves appear; the flower-stalks are from six to nine or ten inches high, covered with a short soft down, which extends along the footstalks of the individual flowers; the flowers are numerous, in terminal spikes, and opening first from below, as in the *Calanthe*; they are much about the size, or hardly so long, as the flowers of *Calanthe veratrifolia*, and are of the most delicate light rose-colour; altogether a charming plant. The pseudo-bulbs are clustered round and round, from two to three inches long, and closely furrowed with sharp angles like an *Echinocactus* without the spines, so that you could pick it out of a thousand species, at first sight, without seeing a flower or leaf; the leaves I did not see, but they are curiously set on the top of the bulbs by a joint, so that they all fall off at once when they are ripe, leaving a flat top to the bulb. The best way to manage it was read to us from a letter sent up with it. That letter recommends a generous, open compost, as for *Phaius*, *Calanthe*, and other ground orchids, encouraging a vigorous growth after the leaves are fully expanded; to cease watering as soon as they turn yellow; and to rest it like a stove bulb in a hot, dry place—or say, by turning the pot on one side on a high shelf in the orchid

house, there to remain until you see it move of its own accord, like an *Amaryllis*. It was sent from Moulmein, by Mr. Thomas Lobb. The genus was named by Blume, and the price is 63s. to 505s. according to size.

Cut flowers of *Zygopetalum Mackayi*, in varieties, and of a fine spike of *Cattleya guttata*, which made my heart ache to see it go without a handsome prize; but such is not awarded to cut flowers, and very properly too. Nothing of the gaudiness of the *Cattleyas* is inherited by this species; the lip is like that in *C. Forbesii*, and the rest greenish, with brown spots thickly dispersed all over the inside. Yet the specimen had a noble appearance, from the large number of flowers, twenty to thirty, set close on the top, exactly like the flower-head of a horse-chesnut. The next plant was the newest and the oldest plant in the room, *Malva umbellata*, a native of New Grenada, and growing there so high up in the mountains as to enable it to live out-of-doors with us through the summer. It was here once before, and lost; the last we heard of it was in 1822, when the lecturer had a beautiful specimen of it from the late Mr. Lambert, from the open air at Boyton, near Salisbury, where it flowered "all over" for a long time in the summer; it makes a dense spreading bush, and throws out its beautiful purplish flowers from the top of the branches like a Geranium. Very likely it cannot be bought before this time twelve-months; but it is well worth while making a memorandum of it. When it will come out, it will not run the circle of a new Geranium—be sold to-day at five times its worth, and the next at not one-third of its real value—as it is in the hands of the Horticultural Society, who will give it to all the nurserymen who are Fellows, when there is a stock of it.

Skimmia Japonica.—The same plant as I mentioned before, and, as I then said, it will be a standing dish with us till late in the spring; or, perhaps, I ought to say Standish's dish, for I think he will not be able to treat us to a better this winter. There is another *Skimmia* in the country, from the north of India, which is very like *Japonica* indeed; it is named *laureola* (laurel-like), because the leaves smell very strong, and like the sweet bay (*Laurus nobilis*). They have been raising a dust about these two beautiful plants, so to be certain, I went to Mr. Jackson's nursery, the evening before this meeting, to see *Skimmia laureola*, for I can almost always see anything new there at my leisure, and I find it is as strongly scented as possible, the leaf is also thinner than in *Japonica*. When I got to Regent-street, I tried *Japonica*, and there is no smell in the leaf, for I spoiled one of them by squeezing to make sure; and now Mr. Standish will know his plant was not hurt by carelessness, and I shall make up the damage.

Tropaeolum Lobbianum.—There were three beautiful nosegays, of three forms, of this useful winter-flowering plant, guarded with leaves of the rose-scented Geranium, sent by Mr. Ayres, of Blackheath. Two of the forms are quite new, and far superior to the species; one of them, called *Triomphe de Gand*, is three times larger than *Lobbianum*, and of a much better and brighter colour (crimson); the other is called *Hockerianum*, is as large as the last, a bright orange with a large crimson dash at the bottom of each of the five petals. He asks 2s. 6d. a plant for it, and it is well worth the money; every one who has a nice warm greenhouse should grow the three—no plants can be easier grown, and they flower profusely all through the winter, and run about like a hop all up the rafters, or trained against the back wall. Cuttings, rooted in the spring, and grown kindly through the summer, will come into bloom in November, and that is the best way to keep on with them; they hold on a long time as cut flowers in a room, and show as bright by candle-light as in the daytime.

Daphne indica rubra.—By far the largest specimen of this I ever saw was here in full bloom, in a square wooden box. I should think it was five feet through, and it looked like a second-sized specimen of the *Azalea indica* at a May show. It was sent by Mr. Edmunds, gardener to the Duke of Devonshire, Chiswick House.

Amaryllis reticulata.—A fine-grown plant, with two scapes, bearing four large reddish flowers each. I notice this to show how little some of the best gardeners in this country know about the names of bulbous plants, for it is really a hybrid *Hippeastrum*, worked from *H. aulicum*. It is quite excusable to call them *Amaryllis*, because the species were published as such before our knowledge of them was complete; but to confound any of the breed of *aulicum*, to the third or fourth generation, with *reticulatum*, or any of its crosses, as far as we know them, shows how little the affinity of bulbs is understood among us. I have not seen the true *reticulatum* these eighteen years, but I can give a sign by which a schoolboy could tell it at once from any of the 400 or 500 species belonging to the order, and also from the more than 4000 varieties into which they have branched out, and that sign is the large white eye at the bottom of the *perianth*, or flower leaves: there is not a single plant in the whole order with this conspicuous mark but itself. The hybrid bulb before us is from *aulicum*, or an early cross from it, by the pollen of *equestre*, or some of its early crosses; and here are the signs—*aulicum* has a large green eye and a smooth eyelid, or margin; *equestre* has the green eye in the form of a star, with a fringed eyelid. Now, the plant in question has a large green eye, not exactly as in *aulicum*, nor quite a star like *equestre*; it has a fringed eyelid, or partly fringed and partly notched: the sepals in *aulicum* are as stiff as wax, and upright; *equestre* has them wavy, and so has this hybrid, but in a less degree; the colour is just intermediate between the two.

There is a distinct class of dwarf Melastomads on the secondary ranges of hills in the East Indies, which are more herbaceous-like than the rest of the order; and they are easily known, from wanting the ribs on the leaves, which is one of the most characteristic features of Melastomads. Roxburgh is the best authority for them. We hardly know any of them in England; we have just got one of them in our Dictionary, an annual, and a second appeared at this meeting from the garden of the Society, and a charming little thing it is; you would take it to be a cross between some dwarf small-leaved *Begonia* and a rose-leaved *Melastoma*. They call it *Sonerila orbiculare*; it is just the sort of thing for an amateur; and although the very leaf of a Melastomad reminds us of a stove and damp atmosphere, the *Sonerilas* will do with the same treatment that suits *Begonias*, and they are just as easily increased. Make a memorandum of this also.

Brugmansia, or rather *Datura sanguinea*. When I first wrote about keeping all the Daturas out in the open ground, from year to year, I was met in more than one quarter with, "Don't you wish you may get it?" Well, we had beautiful blossoms up from Dorsetshire of the red *Datura*, that has been growing out-of-doors there ever since it was introduced, with hardly any protection at all; and if it is cut down, or any of them injured by frost, up they come next year like Fuchsias, and flower as abundantly. This I was told by the gentleman who sent them, the Hon. W. F. Strangways, who has always helped the Society to a knowledge of his half-hardy gardening. We had a whole tray full of cut flowers from the open ground at this meeting, some of which I told of last February, such as *Azara integrifolia*, *Lithospermum rosemarinifolia*, *Edwardsia macrocarpa* and *grandiflora*; this last ripened seed this autumn, at the Bury St. Edmund's botanic garden, on

the open wall. In addition, we had to-day the Spanish *Convolvulus cneorum*, with large white flowers; *Veronica Andersonii*, with lilacy-blue flowers in long round spikes; and one of the honey shrubs from the Cape, *Protea melifera*, with a beautiful flower-bud, shaped like a sharp-pointed cone, all from the open ground. Mr. Pince, of Exeter, sent two new conifers, one a young plant, looking like some glaucous African cypress, the other a sport from the *Chinese arbor-vitæ*, as it appeared to me, with a bluish shade, which, if it keeps true, will make a very distinct thing. From Plymouth, there were Lemons, from an open wall, in the garden of J. Lockyer, Esq., of South Wembury House, as fine-looking as any from abroad. From the garden of the Society we had a large collection of plants, besides the Bush Mallow, and *Sonerila*, such as winter-flowering Heaths, a large collection of *Chrysanthemums*, *Manettia bicolor*, *Triumph de gand Tropæolum*, and others, with one of the best winter-flowering plants belonging to the *Justicias* or *Justicia-looking* plants, with crimson-scarlet flowers, and the name of it made every face in the room smile. Those who hear themselves, night after night, abused, and called everything but senators, without moving a muscle, and even the lecturer himself, whose jaws seem as if made of cast-iron, could not resist the general twitter on his pronouncing the words, "*Sericographis Ghiesbreghtiana*." There was also a good specimen of *Camellia Donkelaeri*, and lots upon lots of the *Pomponé Chrysanthemums*, and a few of the old ones, but that class was lost "between two stools" this season.

I forget if I ever told that her Majesty Queen Victoria, and her Grace the Duchess of Sutherland, are two of the most keen competitors at these shows. There is no mistake about them; it is like diamond cut diamond to see her Grace beating her Majesty, and her Majesty beating the Duchess. The Queen was victorious this time by heavy odds, or full twelve ounces in a 7 lb. 8 oz. Pine Apple, of the smooth-leaved Cayenne, against a 6 lb. 12 oz. Providence. The gallant Colonel Baker, of Salisbury, entered the lists with a beautiful Cayenne Pine, 5 lb. 11 oz. There were several more fine-looking Pines, and the Grapes were excellent—the best Muscats from Mrs. Maubert, of Norwood, and the finest St. Peter's Grapes from Mr. Davis, of Oak Hill, near Barnet. Nothing could exceed the colour and bloom. But, of all the fruit, a splendid dish of the true old Golden Pippin, from Mr. Snow, attracted most notice. They were from an east wall, and the trees are as healthy as the Downton Pippin. D. BEATON.

THE INFLUENCE OF THE BEAUTIFUL.

"I know that there are many of the poor who possess fine feelings, and have a keen sense of the beautiful, but such feelings are suffered to rust out and die, because their possessors are too hard pressed to procure themselves any gratification. Else, why is it that we so often see the Geranium or Rose tree carefully nursed in an old, cracked tea-pot in the poorest room, or the *Morning Glory* planted in a box, and twined about the window? Do not these shew that the human heart yearns for the beautiful in all ranks of life?" Such ideas are not new to the readers of this work. If they do not always mirror themselves from the surface of its pages, it is because every one feels that the strong under-current is ever flowing in that direction. Next to the pleasure of expressing strong-felt convictions, is the delight of finding that these are in unison with the opinions of the gifted and the good. The above extract is culled from a beautiful short sketch of the "Tea Rose," from the pen of the able, right-hearted American writer, Mrs. Stowe. I have long felt, and said, that the

beauty and variety of flowers was one of the strongest material proofs of the beneficence of the Deity. Had it been intended, we should be satisfied *merely* with the *useful*—had it been designed, we should prize and aspire after nothing but what was essential to the supply of our *necessities*—as some are yet hardy enough to contend ought to be the extent of the ambition of the working classes—then is it not likely “we should have only coarse, shapeless piles of provisions lying about the world, instead of all this beautiful variety of trees, and fruits, and flowers?”

One of the features of the times is the enlisting of this feeling of the beautiful as a successful agent in effecting mental refinement and social elevation. Who has not thus seen and felt its power? The cheap but pretty dress; an elegant piece of furniture; a handsome chimney ornament; an artistic-moulded tea-pot; a healthy, clean plant; a cottage, whose very outside says it *must* be kept in order; each and all of these have, at times, done more to promote cleanliness and thrift than the reiterated arguments of moral suasion. Every such object is a standing, ever-present rebuke to filth and sloth. I know there is many a complaint, because in dress, &c., working-people will imitate their betters; but unless carried to an imprudent extreme, I should be a lenient judge in such matters. I confess, on the other hand, that I begin to see traces of manly self-respect, when the young villager *dons* a coat that fits his body, and *doffs* the over-all and cover-all of a sack, called a smock-frock. But, waving such matters, I may be allowed to state, that very many proofs have come under my own observation, in which access to, and love for, the *beautiful*, has completely changed for the better the habits of those subjected to its influence. Nay, more; my own experience justifies me in saying, that so far as *floral beauty* is concerned, in the closeness of the investigation, in the admiration and pleasure perceptible, and in the perfect order, integrity, and propriety of conduct manifested when admitted to range at will within the precincts of a garden, the hard-working men and women of our villages and towns will hardly rank second to any class of the community. Where there is the will, much good may be done without involving either great public show or much self-sacrifice. The Crystal Palace wiped off the unmerited stigma that we were such Goths and Vandals, that our admission amid works and scenes of beauty would just be synonymous with their destruction. We had proved the allegation to be unfounded years before, so far as this neighbourhood is concerned, though I have been given to understand that the county of Herts has not been superlatively distinguished for refinement.

I consider it, then, as a fact proved, not only that floral beauty exerts an elevating power, but that the opening of private gardens, at certain times, to the community, would be considered alike a boon and a source of pleasure. Of course, I make no allusion to such princely places as Trentham and Chatsworth, whose noble proprietors, with large-souled liberality, open their demesnes to visitors every day. Many who could not afford this might yet appropriate several days during the season. I have been urged by many, whose opinion I respect, to mention the method adopted here lately. I retorted, that if it pleased them they had better do it themselves; but then they were so awfully afraid of printer's ink! This was the standing excuse of a friend, who has held some of the highest gardening appointments in the country, and who has repeatedly urged me to make it more public, because it might do great good. If the practice becomes somewhat common, I shall certainly consider this paper one of the most useful I ever wrote.

If I use the plural *we*, it is to avoid confusion, as, properly speaking, as a servant, I could not use the

singular *I*, the modes successfully adopted being either suggested or sanctioned by my worthy employer. When first we began to make a show in the flower-garden in summer, there were a great many visitors, for the largest gardens in the vicinity were far from presenting that high culture and great interest which they *now* do. No gardener of his own accord can well be uncivil to visitors, though I often found they came at most unpropitious periods, when the whole attention and force were required for a definite object. Many, to avoid this, especially if one of the party had ever crossed words with me, used to come after the men had left in an evening, and thus broke in upon the little time I looked upon as peculiarly my own. It is no use denying, therefore, that there was a spice of the *selfish* that led me to agree to the proposal to open the garden to the public one day in the week, during two or three months in the season, and, unless in special exceptions, then *only*. In doing so, for some time I adopted the usual custom of sending an attendant round with each party; but frequently these were so numerous, especially when several villages would turn out the same day, that many would be kept waiting; and then individuals would come and ask “if they might not go round a second time?” These, and other considerations, led us to dispense with the attendant system altogether. We think we make some little improvement every year. Last summer, the gardens were open ten days in as many consecutive weeks, and instead of the whole day, the period was from one, P. M., to six, P. M. Previously to that period, the garden-men had been told of the place they were to occupy at work during the afternoon; so posted, they could see the principal parts, and so as to answer any inquiry that might be put. At the named time, the doors were opened, and people were free to come and free to go: some staying an hour; others several; and others, again, the whole time; there being no porter to admit, and no toll-gate man to let them out.

Has it answered? Last summer, on one of these days, I stood by the side of a great gardener from a large establishment. “I am glad I have come to-day; what a company you have got—the majority are working classes, aint they? How happy they seem! how clean and nicely dressed they are! They seem to go where they please; have you no attendants?” “No.” “Don't you find great mischief done?” “None at all.” “Well, even with attendants, we found ornaments missing from temples and grottoes, &c.; how is it? You don't seem to have even such a thing as an admonitory ticket.” “Can't say; only there *is* something in treating people so as to show you trusted in their honesty and honour.”

Has it given *universal* satisfaction? No! it would be a wonder if it did. Many, who used to come often when they could have the place to themselves, now seldom appear. They are the *betterer* ranks of people—the would-be-aristocracy of the middle classes—the very first to notice, if not to rail at, every other *exclusiveness* except their *own*. Some have told me it was a *pity* the privilege was made so *common*. Others have sent nice little notes, hoping that they, their friends, or families, might come at some other hours and times different from that set apart for the use of the public. Ah! many will talk nicely, and even do a little towards improving the public, provided they are not brought into close personal contact with it. If, however, the test of numbers when the novelty was gone, and faces that spoke of pleasure, be any sure guide, then I may safely say the satisfaction was *general*; and surely the diffusion of rational happiness, even for a few hours, with the after-thoughts and resolves linked and blended with it, is a something worth aiming and trying for.

Keeping in view the ideas with which I commenced, I should like to have something practical, however simple, for a conclusion. Ideas broached on cottage

and window-gardening have brought me statements from various parts of the country. The other day, I had a most interesting letter from the north of Scotland, a few extracts of which I will now give, as bearing upon the "beautiful," leaving others to another time.

"J. —, came quite out in window-gardening. Fine plants of scarlet Geraniums, *Kentish Hero* Calceolarias, and Fuchsias, graced the window-cell, with Nasturtiums, and Canary plants trained up the side, a little amongst the ivy. *People stood and looked as they passed*; it seemed quite a new dodge to the natives. Altogether, it gave the house a very gay and cheerful appearance. Some Hyacinth-glasses, filled with beautiful grasses, which stand on the chimney-piece, look very nice at this season of the year. Could you not launch into *THE COTTAGE GARDENER* an article on Grasses, if so be *dead* flowers were not foreign to your proscribed bounds. I am sure a very interesting graminaceous group might be formed for a few pence. The pots or receptacles, ornamental, if come-at-able, could be filled with moss, with some of the best on the top, and the grasses stuck into it; tufted-growing sorts could be put in so as to appear as tufts; and the looser growing ones could be ranged according to their habits. A few branches of Everlastings might be put in amongst them, by way of variety and embellishment. To cottagers of limited means, a group of this sort, even on the window-sill, might be a great source of enjoyment, at once cheap, pleasing, and interesting."

I can confirm the above statement. Knotted grass, Feathery grass, and Shaking grass, &c., have been coming into vogue in this neighbourhood for two years, and that solely owing to the example of a young lady, a tradesman's wife, who ranged the hedge-sides for them about the time they were in bloom. She lived in a pretty cottage by the highway-side. In ordinary cases, it would have presented nothing *extraordinary*; under her tending care it became a miniature Paradise for neatness and beauty. At a pinch, she has frequently been known to *clip* and clean her grass-plot in a morning; but her next to ubiquitous movements were not confined to garden and house. The love of the beautiful was no dreamy inoperative principle with her. It acted itself out in kindness and sympathy. Hear of an accident, a heavy misfortune, a severe case of affliction, and you hear of that woman having been there, to cheer, to console, to help by word and deed. She has removed to another part of the country, amid the regrets and the warm sympathies of a neighbourhood. But the influence of her little garden and her large heart have *not* gone. Every bunch of feathery grass keeps her in remembrance.

A few bunches of Everlasting Flowers between the bunches of grass are a great improvement in such groups. The other day I saw a bunch of the flowers of *Aphelaxis* so used. The whole of that genus, and also *Phenocoma*, *Helichrysum*, *Gnaphalium*, and *Xeranthemum*, may be so employed. *Gnaphalium arenarium*, *graveolens*, and *candidissimum*, are low-growing, hardy, herbaceous plants that any cottager may grow by the side of a pathway. They are now generally grouped under *Helichrysum*. The first-named has beautiful yellow flowers, which will retain their beauty for years, though I cannot say where it is to be had, as this bedding-system is making sad havoc with fine old plants. Then, there are the *Xeranthemums*, free-growing annuals, which require to be sown in April, in common soil, and though they grow generally three feet in height, yet the flowers, when well dried, will keep their colour for years. Such low-growing, hardy annual *Gnaphaliums*, as *obtusifolium*, *sanguineum*, and *undulatum*, may be so used, and all present a very pretty effect.

R. FISH.

THE CHRYSANTHEMUM.

A CORRESPONDENT (*Cato*) has written requesting information respecting the cultivation of this very fine autumnal flower, so as to produce such blooms as Mr. Taylor exhibited at the Stoke Newington Show on the 23rd of last month, and also a list of the best varieties, to enable him to select a collection from. I did write a short paper or two on the culture of the Chrysanthemum some two years back, and the heads of those papers are in the Dictionary also. Since those papers were written there has been a great improvement both in culture and in the varieties, so that I think a few additional instructions, and a list of the best varieties, will be acceptable not only to "Cato," but also to our readers generally, especially such as do not possess the entire *COTTAGE GARDENER*, or *The Cottage Gardeners' Dictionary*, though I may venture to say the latter work ought to be in the hands of every cultivator of plants, fruits, or vegetables, in Great Britain.

There is one recommendation to the *Chrysanthemum* that no other florists' flower possesses, and that is, it is so easily kept through the winter. All the rest, if I except the Rose, and perhaps the Fuchsia, have a difficulty about them which renders their preservation unscathed through that dreary season a matter of care and uncertainty; but the *Chrysanthemum* may be preserved with the least care imaginable, either in a pit or cold frame, or even out-of-doors, if the pots are plunged over head in coal-ashes, placed on the south side of a wall, or low evergreen hedge. The only protection they require is a light covering, in very severe frost, of dried bracken or common fern.

In addition to this extreme hardihood, this plant is as easy to propagate as a willow, every cutting will grow, and it can be propagated also by layers and seeds. I will briefly describe these three modes.

By Cuttings.—The best are the young tops, taken off when four or five inches high; reduce them to three inches in length, cut off the extreme top, and about an inch of the bottom; trim off the lower leaves, and put the cuttings round the edge of a five-inch pot, filled with light rich earth, and a thin layer of pure sand on the surface; then give a gentle watering, and place them on a heated surface of sand, or plunge them in a gentle tan-bed, placing a large hand-glass over them. This should be done as soon as the shoots can be got, in order to have them in a forward state early in the year. They will, with moderate care as to shading and watering, soon make roots, and should be immediately potted off into small pots; let the tops be cut off again, and subject them to this treatment every time they are potted, in order to cause side-shoots to break out, and thus form low, bushy plants early in the season. This is a desirable point to accomplish as soon as possible; for if they once get legs, long as a greyhound, their beauty is spoiled for that season: no cutting down afterwards will effect a reformation in their appearance.

By Layers.—The branches, when simply brought down to the soil, emit roots plentifully. This facility of rooting is taken advantage of to obtain low bushy plants. To effect this, plant out in an open situation a lot of old plants. If the plants are laid sideways when planted, the shoots can be pegged down into small pots more easily. These make low, bushy plants, well furnished with flower-buds, with very little trouble. Cut the layers off as soon as the pots are filled with roots, repot them into six-inch pots, and shade for a few days until they are fairly established, then treat them as you would the plants raised from cuttings.

By Seed.—This is not very plentifully produced in our dark, foggy climate, but it is produced in green-houses sparingly. Save and dry, and keep it dry till February or March. Then sow it in shallow pots, in

light, rich soil; sow shallow, and cover slightly with very fine sifted soil, giving very gentle waterings when the soil is dry. The young seedlings are very succulent, and soon damp off if too freely watered, or in too damp heat. The best place for them is on a shelf close to the glass of a good greenhouse. Prick out the seedlings, as soon as they can be taken hold of, into the same sort of shallow pot, and when they have made a still further growth, pot them singly into three-inch pots, and afterwards treat them as you would cuttings. Some may flower the first year, but they will all certainly bloom the second. This is the only way to procure new and improved varieties.

To cultivate the *Chrysanthemum* with a view to exhibit it, some extra care must be devoted to it. During the time of growth, the plants should be fully exposed to sun, light, and air. They should by no means be crowded together, or amongst other plants. The best situation I ever found for them was in a single row, on the side of an open walk. In this situation, from May to August, they will grow bushy, be furnished with broad, healthy foliage to the pot edge—that is, if rightly managed in three particulars, namely, repotting in very rich soil; freely watering at the root (occasionally with liquid manure), and frequently syringing over the leaves and branches; and, lastly, frequently stopping. At the end of August they should be in nine-inch pots, and then should be stout, bushy plants, with the flower buds in abeyance, or dormant. The buds should just make their appearance in September, and grow on slowly till October. The plants will then be really handsome objects, independent of bloom, and will require no sticks, nor any kind of support.

In order to have a greater show of bloom, some growers place three or four plants in a pot, but I cannot commend that practice. A greater number of flowers is obtained, it is true; but it is at the cost of a sacrifice in the size. The largest and finest flowers are always produced on single plants, and no censor will give a plant a prize in preference because it has a greater number of inferior blooms upon it. If not intended for exhibition, the placing a number of plants in a pot or tub may be a praiseworthy practice. I saw, very lately, in the conservatory in the Royal Botanical Society's Garden, in Regent's Park, a box, more than two feet across, closely filled with many plants of a tasselled-flowered *Chrysanthemum*, and a fine object as a mass of bloom it certainly was; but when the flowers were examined individually they were very common-place indeed. I have, in my greenhouse, several pots, with three or four plants in each, which, viewed at a distance, are very passable—nay, even showy; but they are not fit for an exhibition. "Cato," and every grower for exhibition, then, will be wise if they adopt the single-plant-in-a-pot system, if they wish to have really large, good flowers, either to be exhibited in pots or cut blooms.

T. APPELBY.

(To be continued.)

CONSERVATIVE WALLS.

(Continued from page 184.)

WHAT is the use of a *Conservative Wall*? Previously to putting up any building, the first consideration is, of what use is it? That is the question. To the strict utilitarian, whose ideas are confined to the profit and loss on any undertaking, the conservative wall will appear a perfectly useless building; the objects to be grown against it are useful neither for food nor clothing. To a mind so narrowed, I cannot produce any argument to prove that a wall to be covered with ornamental and flowering shrubs is of any use. He could easily understand that a pinery, a vinery, or a peach-house would

be of some use. The fruit would be fit to eat! and would be a pleasing enjoyment after dinner, accompanied by a glass of good wine. I do not deny this, by any means; and, in addition to the mere eating of such delicious fruit, there is, to a more elevated mind, quite as much enjoyment in seeing such fruits bloom, grow, and come to perfection. To a mind still more refined, there is a still higher enjoyment in cultivating and bringing to a high state of perfection plants cultivated only for their fine foliage, or highly-perfumed beautiful flowers, the gems of the earth. Shakspeare says, "the man that delights not in music is not to be trusted;" and I may venture to say, that the mind that delights not in flowers cannot be very amiable!

Now, the use of a conservative wall is to grow plants against it to a higher state of perfection than they can be grown in pots, more especially such plants as will not quite bear the vicissitudes of our climate. For such purposes it is admirably adapted; and this is no theory only, it has been borne out in practice in various places—private gardens. I mentioned some in my last paper on this subject, and now I need only refer to the conservative walls at Kew and Chiswick, as instances of public gardens, where they may be seen clothed with beautiful specimens of plants in the greatest luxuriance. But there is another use of plants grown in this manner, and that is, the proving their capability of bearing our climate. Many plants are imported from warmer climates, of whose power to resist or bear our frosts we have no knowledge. I remember the day when the *Aucuba Japonica* was cultivated in the greenhouse only, and now every tyro in gardening knows that it has proved one of the hardiest of our evergreens. Had conservative walls been in existence then, this plant would have been planted against it, and its perfect hardihood proved at once. Again; if there is any truth in the doctrine of acclimation, or the art of hardening, this wall is a proper school for the plants; and it would be a very interesting pursuit to endeavour to acclimatize plants by placing them first against and under the sheltering influence of such a wall previously to planting them out in the open border, when they had acquired a woody texture; for it is a well-known fact, that old hard-woody plants will bear a greater degree of cold than the same plants when young and soft-wooded. And, thirdly, plants against such a wall are more certain to bear seed than such as are grown in pots, or even in the borders of a conservatory, for this reason—in such a situation they are more likely, nay, certain, to produce seeds, from the fact that they have more of the stimulants (air and light, combined with protection) to cause such a natural effect. The production of seed is a step gained in the art of hardening plants, because it is supposed that plants raised from seed saved in a colder climate than their native habitat will have a more robust constitution, and thus, by a natural process from generation to generation, the great grand-children of plants brought originally from Japan or Mexico will be as hardy as our oak or hazel. I do not say positively this will be so, because I do not forget that the *Dahlia*, the *Potato*, the *Cucumber*, and the *Melon*, are probably as tender now as they were the first year of their introduction; but it is plants with a more woody texture that would probably be acclimatized, if the art of hardening by a conservative-wall were systematically and judiciously carried on for several generations.

Such is my answer to the question, What is the use of a conservative wall? and I think the reasons given are quite sufficient to bear out the idea, that it is a useful as well as a beautiful object; and then follows the second query, How is it to be built? The answer to this will include the aspect, material, and the mode. The aspect of that model of a conservative wall at

Chatsworth is nearly due west, and though, in that instance, the aspect is of little consequence, because of its being heated, yet, in the case of a wall not heated, that aspect is, I conceive, the very best, and for this reason, should a frost happen any night, the plants may be slightly touched with it, but will have time to be gradually thawed before the sun reaches them, and so be less injured than they would be if the wall had an east or a south aspect. For the sudden extremes of heat and cold, or *vice versa*, are the circumstances so destructive to half-hardy plants. Even a north is better than a south aspect, though not to be preferred for many plants; yet the *Camellia* thrives best on a north aspect if planted out-of-doors. Several instances of this may be seen at Chiswick. They are planted there close to a wall on the north side, and grow well, and frequently flower well too, if there is a season without late spring frosts. The reason of this is easily understood; they are not subject to such sudden and violent changes of temperature as they would be if planted against a wall with a south aspect, and so are not stimulated into growth so early in the season as to be nipt by the frost.

The west, then, is the best aspect for the generality of plants suitable for a conservative wall, and the material I consider the best is a dark-coloured brick; dark colour retains the heat, light colour repels it; hence it is, that a black coat is warmer than a white one on a sunshiny day. If the dark wall has had the sun shining upon it the whole of the afternoon, it will retain the heat much longer than a light-coloured one. This is a fact I need not prove. Then a dark brick should be the material, if the wall is not heated artificially. The way or mode by which this wall should be built, is first to lay a good foundation, broader than ordinary, in order to allow space to have a hollow space in it, whether it is to be heated or not, for that is a fact now well understood, that a hollow wall is warmer than a solid one. Indeed, all garden-walls, whether for the purpose of growing plants or fruits, should be constructed in this manner.

T. APPLEBY.

(To be continued.)

THE BIRMINGHAM POULTRY SHOW.

SEVERAL attempts have been made, of late years, with more or less success, to trace the history and origin of our different varieties of domestic poultry. There is, however, no difficulty either in ascertaining the commencement of those exhibitions which have done so much to improve the quality, and to extend the taste for the purer and better breeds of poultry, or in tracing the steps by which they have, in a wonderfully short space of time, obtained gradually, and almost imperceptibly, their present high position.

To the Yorkshiremen, we are undoubtedly indebted for having originated and brought to a considerable degree of maturity these interesting gatherings; and we remember the time when it was thought almost a reproach upon the proverbial shrewdness of our Yorkshire friends, that they had given themselves so much trouble upon what had been long considered so trifling a subject. They, however, persevered, and soon established, within the circumference of a few miles, poultry shows at Leeds, Bradford, Huddersfield, Halifax, Keighley, Otley, Weatherby, Holmfirth, Stanwood, and Bretton, each of which, in its locality, is well supported.

But it remained for the Birmingham and Midland Counties Society to make the attempt on a large scale. They soon succeeded in establishing an exhibition which has not yet been approached either in point of numbers or of excellence; and they are fairly entitled to divide with their more northern brethren the credit of having revived and brought to its present state of advancement this interesting and profitable branch of rural economy. Poultry, which had been looked upon by the farmer as beneath his notice, has now, by their exertions, become a source at once of profit and of pleasure; and, in proportion

to the food it consumes (much of which would otherwise be wasted), and to the capital and labour employed, is, we undertake to say, as remunerative as any stock upon his farm. To the country gentleman, the amateur, and the fancier, what so ornamental, and at the same time so useful, as a nice, uniform lot of pure-bred fowls? The ladies, too, may participate both in the amusement and the benefit derived from their feathered favourites, from the stately Shanghai, and the brilliant Spaniard, down to the little dapper Golden or Silver Sebright Bantam, rivalling the pheasant in beauty. And—last, not least—can a cottager keep anything about his premises from which he and his family may derive more of mingled pleasure and profit than a few heads of good poultry?

For the gratification, and, we trust, for the benefit, of all classes of our readers, it is to a description—impartial, we hope, and not unprofitable to the poultry-keeping world—of the fourth exhibition at Birmingham, that we purpose to-day to devote a greater proportion of our paper than is usually given to one subject.

This exhibition commenced on Tuesday, the 14th of December, in the capacious and well-lighted building known as Bingley Hall. Considerable improvements have been made in the hall itself since the last show took place within its walls, and the visitors are indebted to the proprietors and the committee for a corresponding increase in the comfort they enjoy, and the facilities afforded to them in viewing the specimens. Indeed, the arrangements in these respects appeared to us to be quite unexceptionable.

In point of numbers, the exhibition of 1852 exceeded that of 1851 in every class, as the following table (which may be interesting for purposes of reference) will show:—

Classes.	PENS ENTERED.	
	1851.	1852.
Spanish	53	61
Dorking	117	142
Shanghai	154	275
Malays	35	10
Game	127	164
Golden-pencilled Hamburgs ..	20	13
Golden-spangled Hamburgs ..	21	28
Silver-pencilled Hamburgs ..	48	58
Silver-spangled Hamburgs ..	44	66
Poland	41	68
Cuckoo	5	6
Rumpless	6	4
White-crested Golden Hamburgs	2	—
Andalusian	5	2
Ancona	6	1
Frizzled	1	4
Norfolk or Surrey	2	2
Bantams, Gold-laced	20	35
" Silver-laced	11	6
" White	10	12
" Black	16	13
" other varieties	6	5
Pigeons	120	85
Geese	17	18
Ducks	71	73
Turkeys	25	23
Guinea-fowl	14	6
Extra Class	36	—

The managers of the show have this year omitted some of the varieties, or sub-varieties, included in the list of last year. With all due deference, we question the propriety of this alteration. Although principally got up for the benefit of the farmer and the amateur, these exhibitions are interesting to the scientific naturalist, and have derived, in their time, much benefit from his investigations and researches. To him, independently of their beauty, and the pleasing variety they made, the specimens entered last year as "Ornamental Poultry," and several curious sub-varieties besides, were of peculiar interest, while they were objects of attraction to others also. We hope to see room afforded, upon future occasions, for specimens of this description.

We should also strongly recommend a reconsideration of the rule which permits old and young fowl to be shown in competition in the *same* classes. Where there are classes

for chickens exclusively, *all* chickens should, in our opinion, be shown in them. In many varieties, especially of what are known among fanciers as "feathered fowl," old birds are shown to a great disadvantage against chickens, whose feathers are necessarily more *clean and pure* in colour; and in every class this practice admits of a sort of speculation on the part of the judges, whether or not the chickens *will* some day be better than the old fowls *are* now; instead of their being confined, as, we submit, they ought to be, to a simple, because certain, decision which of the two or more pens is the *best at the time of the show*.

Before we proceed to notice the different classes, we will mention the only other drawback—and in our opinion it is a serious one—to the Birmingham Show. It is the very objectionable practice of employing a dealer as one of the judges. To it may undoubtedly be traced the dissatisfaction, "not loud, but deep," expressed by many good judges, both at the last and the present show, with some of the awards made. We have no personal feeling in the matter; it is to the *principle*, and not to the individual, that we object. It is not in the nature of things that the confidence of the public should be placed, or expected, in any man who may be the seller of the very birds of which he is called upon to judge. It is to inspire confidence on the part of the exhibitors—not to attach suspicion to the judges—that we thus contend that dealers should not be eligible as judges. The task of finding fault is always an invidious one, but as public journalists, and having the public good exclusively within our view, we cannot be silent upon a point which is operating much to the disadvantage of exhibitions, which we are convinced, although yet, as it were, in their infancy, have done, and are doing, much good; the more especially when *we know* the opinions of many of the owners of the best stock, and that gentlemen of the highest character and honour, and who are as good judges of poultry as England can produce, have repeatedly refused to act in the capacity of judges at our shows, on the ground alone, that they will not, by becoming their colleagues, countenance the engagement of dealers as judges. Hence it is clear that more is lost than can be gained by employing the latter. We are by no means sure that the Birmingham committee themselves have not met with such refusals this very year; but we know that in the recent case of the Hitchin show, Birmingham itself, York, Leeds, and Hull, were ransacked up to the very day before the show took place for a judge, and that there was no other difficulty in the way. For these reasons, we very sincerely trust that this manifest evil will be remedied another year, before its consequences are more severely felt; that confidence, lost in some, and waning in many amateurs, may be restored; and that, all cause of suspicion being thus removed, the decisions of the judges will be acquiesced in with that respect which confidence can alone inspire.

We now turn, with pleasure, from the ungracious office of fault-finding, to the details of what has been altogether—in spite of the drawbacks arising from the causes to which we have just referred—one of the best shows of poultry (if not the very best) upon record.

We need scarcely say that the classes, where there were so many, were unequal in point of merit. Following the orders of the catalogue, we commence our observations with the *Spanish*. Until the Cochins became, within the last year or two, dispersed throughout the country, no race of fowl were greater favourites than the Spaniards. The brilliant lustre of their sable plumes, contrasted with the white face and red comb—their size, their stately and upright carriage, combine to make the male bird one of the most beautiful of our domestic fowl; while the glossy and uniform appearance of the hens render a nice flock of Spanish most agreeable to the eye. So much so, indeed, that they are often styled "the gentleman's fowl."

In point of quality, the birds exhibited appeared to us to be much superior to those of last year.

In our recent account of a visit to his poultry-yards at Knowsley, we took occasion to say, that he who should beat Captain Hornby in the Spanish classes, at Birmingham, must show good birds in their best form. We were not far wrong, for the Captain has certainly made a tolerably clean sweep of it in these classes, having carried off the first and second prizes (the latter, in our opinion, being the better

pen). In the Spanish chicken class, the first prize was awarded to Mr. J. O. Smith, of Skelton Grange, near York; and we think his birds well deserved the honour.

The next classes comprise the different varieties of the *Dorking family*; and we think the committee have taken a mistaken step in offering separate prizes for Dorkings with double or rose combs. Such, in our opinion, and in that of most of the best judges, so far as we have been able to collect them, are of questionable purity as Dorking fowls, and, at all events, are quite unworthy of separate premiums at such a show as that of Birmingham. The grey and sober plumage of the Dorkings presents an agreeable contrast to the more gay feathering of some of their competitors; and their peculiarly neat and "squat" build points them out, as in truth they are, as the very fowl for the table. The advantage of the Dorkings is, that their meat is packed into a small compass, and, for the purposes of the cook alone, we are not sure that the Dorking does not bear away the palm from all competitors. But, taking all points together (and we may as well repeat that, in giving an opinion of the relative merits of different varieties, we have always in view the question—which of them combines the *most* good qualities with the fewest defects), we are of opinion that the Shanghaes and Spanish are superior to the Dorkings. In these, as in the Spanish classes, the number of pens was greater this year than last, and we think their contents at least equal in quality. The first prize in the principal class was awarded to T. T. Parker, Esq., of Sutton Grange, for a splendid pen of birds; the second falling to the lot of Captain Hornby, for one scarcely inferior to it.

We have already said that the general verdict of the poultry-keeping world has, in our opinion, in spite of the hue raised against them by the dealers, indisputably been pronounced in favour of the *Shanghaes*; and we think, taking all points into consideration, correctly so. In point of beauty, opinions may differ; but their great bulk, added to neat and compact appearance, their fecundity, and the ease with which they may be kept within any enclosure, however slight, renders them, without regard to other considerations, a most desirable fowl. Their very singularities—the stumpy tail and feathered leg—are not displeasing by way of variety, and they are, moreover, quiet and gentle in habits and disposition to a degree. But, whether we be right or wrong in awarding to them, as we are at present disposed to do, the palm over all other varieties known in this country, certain it is that—for the present, at all events—they are the reigning favourites. The prices for which they have been, and are, sold; the length of time during which those enormous prices have been kept up; the interest concentrated upon them at every show we go to; prove, beyond cavil, that the fact is as we have stated. To this observation, their position at the Birmingham show was no exception. From day to day, and from hour to hour, the thickest of the crowd surrounded the pens containing the different sub-varieties of these beautiful birds. Since the last exhibition the Shanghaes have been divided into three classes—the whites, the cinnamons and buffs, and the browns and partridge-feathered. Why the greys and blacks have been excluded we are not aware. Taking the subdivisions in the order we have given, the white first claim our notice. Inferior in size to some of their relatives, yet upon a lawn, or in a clean country place, what can look prettier than a neat uniform lot of these beautiful birds? They have already become prime favourites, especially among the ladies, and, we think, are likely to continue so.

In this sub-division, which was superior, both in number and quality, to those shown in the same classes in 1851, the first prizes, both for old fowl and for chickens, were awarded to Mrs. Herbert, of Powick. The second prize for the old birds was given to Mr. G. C. Peters, of Moseley; and the third to Mr. George Graham, of Yardley, whose pen appeared to us, and to many others, to be at least equal to the other two.

Of the numerous shades of colour prevailing among the Shanghae fowl, none has become so popular as the neat and pretty buff; and certainly there is something peculiarly pleasing in its quiet uniformity. Whether from this or other causes we know not, but the buffs have certainly commanded higher prices than those of any other colour. It is, therefore, not surprising that in this class the greatest

interest appeared to be centred—so much so, that it was really difficult to obtain time and space sufficient to get a good view of them. In every show the “observed of all observers,” here, where the best of each sort are congregated together, we have a right to expect the best of these also. Hence the interest they excited, which was certainly by no means disappointed. In one word, we can say nothing for the buff class which has not been said and proved by the preference everywhere accorded to them, although we really do not think this class was so good, as a whole, as the corresponding class of last year.

With regard to the dark varieties, we are not of those who, on the one hand, decry them; nor do we, on the other, think them, as some do, either more hardy or superior in weight to their light-coloured relatives. In truth, we think there are equally fine kinds of the buff, the cinnamon, and the dark varieties; and we know that it is difficult to find chickens, of any breed, more easy to be reared than are the buff Shanghaes. For those who reside near large towns we might recommend the darker birds, on the ground that it is better to keep good birds of a colour which is not so easily soiled, than to have birds of better quality, yet of a shade so light that they cannot be kept, in that locality, in perfect purity of plumage.

Reverting to the prize-list, we find that in the buff class of older birds Mr. Sturgeon maintains his old position—a higher he cannot attain. Mr. Cattell, of Moseley Wake Green, obtained the second prize; and Mr. Steggall, of Weymouth, the third. In the corresponding class of young fowls of 1852, the first prize was awarded to Mr. Cattell; the second to Thomas Roscoe (Captain Hornby's servant); and the third to Mr. Punchard. It was to the awards in this latter class that the greatest exception was taken; and, after much examination, we are bound to declare our opinion in favour of the malcontents.

Prizes were also given for the best pair of buff, cinnamon, or brown: the first to Dr. Gwynne, of Sandbach; the second to Mr. Punchard; and the third to Mr. H. G. Smith. Mr. Punchard also obtained a commendation for what was thought by many the best pen of the four; and this opinion was partly borne out by the fact, that the pair of birds were sold for £25. We wish Mr. Punchard as good a sale on the 4th of January as that which Mr. Sturgeon was fortunate enough to secure.

The next class, in order, are the *Malays*. These have hitherto been a favourite fowl; and certainly there is a stateliness and an appearance of high-breeding about a true Malay which is particularly commanding. We cannot but regret that so handsome and pure a breed of fowls should, all at once, have become nearly extinct; although we must admit, that in point of utility they are not equal to the Cochins, the Spanish, or the Dorkings.

Next in order, come the type of courage—the old English *Game*. The days of cock-fighting are happily at an end in this country, but we can still admire the martial appearance and bearing of the different sub-varieties of those truly “game” birds which were wont, in old times, to contend in the cock-pit. For beauty and variety of plumage, closeness of feathers, and purposes of utility combined, there is, we really believe, no one of the smaller varieties of our domestic poultry preferable to the Game. In the northern counties, the pitmen and cottagers prefer them to all other sorts within their reach; and the degree of perfection to which they are brought, if not so great as in the times when fortunes and estates depended upon the result of their encounters, is still considerable. To us they are interesting, as one of the “poor man's fowls;” and sure we are that a cottager can keep none upon less food, or to greater advantage, while they will never shame the poultry-yard of a gentleman. For the numerous prizes awarded, we refer to the list which we subjoin; and we think we may say, without fear of contradiction, that the Game classes were the best in the exhibition.

The *Pencilled Hamburg* next claim our attention. These, like the Game, are, though in different localities, the favourites of the cottagers. In the West Riding of Yorkshire and parts of Lancashire, there is scarcely a cottage which cannot boast of its few “Chittaprats,” as they are there called. As they may not be known to many of our readers, we may add that there is not a prettier race of fowls extant than the

Pencilled Hamburgs, whether golden or silver,—nor one, which, in proportion to its size, is of more real use to the farmer or the cottager. We cannot, however, say we think the collection of these pretty fowls was first rate. The golden were better than the silver ones—the latter, indeed, would not bear comparison with those exhibited at the small shows in the Yorkshire towns.

Following naturally in order come the *Spangled Hamburgs*, called in Yorkshire, where they also are principally cultivated, “gold and silver pheasants.” These, again, are beautifully feathered kinds; and, like the Pencilled varieties, capital layers; and, therefore, most useful to the poor man. Our Shanghae and Spanish fanciers would scarcely suppose that their poorer brethren in Yorkshire will discuss the merits and demerits of their Chittaprats, or gold or silver pheasants, and point out, to a feather, the difference between them, with all the zest and interest which they themselves bestow upon their own more costly and gorgeous favourites. And woe betide the judge, who, at one of the Yorkshire shows, should make a mistake in deciding between the pens of rivals, each as competent, or more so, to exercise a judgment as himself.

Of the *Polish* fowls, which are next in rotation, so much has been said of late, that, without meaning at all to disparage them, we shall not be at all surprised to find that some of our friends, who have purchased them of the dealers, may discover, before long, that they have got considerably less than their “pennyworth for their penny.” Yet the Polands, of which there are several tolerably distinct varieties, are exceedingly pretty, and are, moreover, for their size, useful fowl. The plumage of the blacks, which almost equals that of the Spanish in brilliancy, is contrasted to advantage with the pretty white crest which is common to both sexes. The Golden and Silver Polands have the latter characteristic in the same perfection; and although the contrast between the black plumage and white crest does not hold good, it is more than made up for by the beautiful markings of the varieties now under notice. The Polands are, by the efforts of the dealers, rising in favour; and although we are not prepared to say that it is not deservedly so, yet we are sure that the prices which have been given for them are perfectly ridiculous, and such as never can be maintained. For the several prizes awarded, we refer to the list, only adding that the Polands, as a whole, are decidedly an improvement upon the last year's show, and added considerably to the interest of the exhibition.

Of the *Bantams*, generally one of the prettiest features of a large gathering like this, we shall only say that they were decidedly inferior in quality to those shown at many of the minor exhibitions.

We do not think that either the *Geese* or *Turkeys* were so good as those exhibited on former occasions.

Of *Ducks*, some good specimens were exhibited; and the Aylesburys shown by Lord Hill were well worthy of the first prize awarded to them, as were the Rouens of Mr. Charles Punchard, which, in their class, obtained a like premium.

Upon the whole, we do not hesitate to say that the Show of 1852 was not, in point of general merit, at all superior to its predecessor. We doubt if so many good birds were shown; and we are sure there were more of a decidedly inferior character. There are several reasons, combining probably, to produce this result. We have already adverted, not without pain, to some of them; and we submit, in conclusion, to the managers of future anniversaries, that the time for which the birds are kept is really too long. If one day was given up, so that the birds need not be brought in until the Monday evening, two days would be gained to them; and we hope and believe nothing would be lost to the exhibition or to the public. Sure we are that exhibitors would be better satisfied; and we are strongly inclined to think that the owners of many good birds, who now keep them at home, would, if this and the other objections to which we have, in no unfriendly spirit, thought it our duty to advert, were obviated, no longer object to send them to Birmingham. If the Show is to be kept up at all upon the scale it has already attained, to say nothing of improvement, most of these points must necessarily force themselves upon the attention of those in office. This is our only object in putting them forward; and we very sincerely trust that all

causes of jealousy and suspicion being removed, the subscribers will work harmoniously together; and that we may for many years look upon the Exhibition at Birmingham as a standard Poultry Show.

We publish the full prize-list, as follows:—

Class 1.—SPANISH.

(For the best Cock and three Hens of any age.)

5. First prize, 2*l.* 2*s.*, Mrs. Windham Hornby, Knowsley Cottage, Prescot.
3. Second ditto, 1*l.* 1*s.*, Captain Windham Hornby, Knowsley Cottage, Prescot.

Class 2.—SPANISH.

(For the best Cock and three Pullets, Chickens of 1852.)

25. First prize, 1*l.* 1*s.*, Mr. John Hill Smith, Skelton Grange, York.
33. Second ditto, 10*s.*, Mr. Richard Taylor, Ward End Mills.
27. Third ditto, 5*s.*, Captain Windham Hornby, Knowsley Cottage, Prescot.

The whole of this class highly meritorious.

Class 3.—SPANISH.

(For the best Cock and one Hen of any age.)

58. First prize, 15*s.*, Mr. John Henry Peck, Wigan.
56. Second ditto, 10*s.*, Mr. John Taylor, jun., Cressy House, Shepherd's Bush, London.

Class 4.—DORKING (Single-combed).

(For the best Cock and three Hens of any age.)

95. First prize, 2*l.* 2*s.*, Thomas Townley Parker, Esq., Sutton Grange, St. Helen's, Lancashire.
72. Second ditto, 1*l.* 1*s.*, Captain Windham Hornby, Knowsley Cottage, Prescot.

Class 5.—DORKING (Single-combed).

(For the best Cock and three Pullets, Chickens of 1852.)

109. First prize, 1*l.* 1*s.*, Captain Windham Hornby, Knowsley Cottage, Prescot.
113. Second ditto, 10*s.*, Mr. James Drewry, Newton Mount, Burton-upon-Trent.
119. Third ditto, 5*s.*, Mr. Edward Lister, Cassia Lodge, near Over, Cheshire.

The whole class highly commendable.

Class 6.—DORKING (Double or Rose-combed).

(For the best Cock and three Hens of any age.)

139. First prize, 2*l.* 2*s.*, Miss Elizabeth Steele Perkins, Sutton Coldfield.
141. Second ditto, 1*l.* 1*s.*, Mr. John Huskins, Wilnecote, near Fazeley, Staffordshire.
138. Third ditto, 15*s.*, The Reverend John Robinson, Widmerpool, near Nottingham.

Class 7.—DORKING (Double or Rose-combed).

(For the best Cock and three Pullets, Chickens of 1852.)

143. First prize, 1*l.* 1*s.*, Mrs. Windham Hornby, Knowsley Cottage, Prescot.
146. Second ditto, 10*s.*, Sir John Cathcart, Bart., Cooper's Hill, Chertsey, Surrey.
150. Third ditto, 5*s.*, Mr. James Drewry, Newton Mount, Burton-upon-Trent.

Class 8.—DORKING (Double or Single-combed).

(For the best Cock and one Pullet, Chickens of 1852.)

163. First prize, 15*s.*, Mrs. Windham Hornby, Knowsley Cottage, Prescot.
175. Second ditto, 10*s.*, The Reverend M. W. F. Thursby, Abington Rectory, near Northampton.

Class 9.—DORKING (White).

(For the best Cock and three Hens of any age.)

188. First prize, 2*l.* 2*s.*, The Right Honourable the Earl of Dartmouth, Sandwell.
194. Second ditto, 1*l.* 1*s.*, Mr. Joseph Jennens, Moseley, Birmingham.
Third prize withheld.

Class 10.—DORKING (White).

(For the best Cock and three Pullets, Chickens of 1852.)

205. First prize, 1*l.* 1*s.*, Mr. John Brearley Payn, Vicarage Road, Edgbaston.
200. Second ditto, 10*s.*, The Right Honourable the Earl of Dartmouth, Sandwell.
202. Third ditto, 5*s.*, The Reverend Edward Elmhirst, Shawell Rectory, Leicestershire

Class 11.—COCHIN-CHINA (Cinnamon and Buff).

(For the best Cock and three Hens of any age.)

225. First prize, 2*l.* 2*s.*, Mr. Thomas Sturgeon, Manor House, Grays, Essex.
212. Second ditto, 1*l.* 1*s.*, Mr. James Cattell, Moseley Wake Green, near Birmingham.
224. Third ditto, 15*s.*, Mr. F. C. Steggall, Weymouth, Dorsetshire.

Class 12.—COCHIN-CHINA (Cinnamon and Buff).

(For the best Cock and three Pullets, Chickens of 1852.)

294. First prize, 1*l.* 1*s.*, Mr. James Cattell, Moseley Wake Green, near Birmingham.
272. Second ditto, 10*s.*, Mr. Thomas Roscoe, Knowsley, near Prescot.
275. Third ditto, 5*s.*, Mr. Charles Punchard, Blunt's Hall, Haverhill, Suffolk.

Class 13.—COCHIN-CHINA (Brown, and Partridge-feathered).

(For the best Cock and three Hens of any age.)

335. First prize 2*l.* 2*s.*, Mr. Edward Farmer, Greet, Sparkbrook, near Birmingham.
338. Second ditto, 1*l.* 1*s.*, Mr. Thomas Atkins, Dursley, Gloucestershire, and Babbicombe, Torquay, Devonshire.
332. Third ditto, 15*s.*, Mr. Thomas Smith, Cheapside, Birmingham.

Class 14. COCHIN-CHINA (Brown, and Partridge-feathered).

(For the best Cock and three Pullets, Chickens of 1852.)

361. First prize, 1*l.* 1*s.*, Mr. Thomas Atkins, Dursley, Gloucestershire, and Babbicombe, Torquay, Devonshire.
355. Second ditto, 10*s.*, Mr. Charles Punchard, Blunt's Hall, Haverhill, Suffolk.
349. Third ditto, 5*s.*, George Tollet, Esq., Betley Hall, Staffordshire.

Class 15.—COCHIN-CHINA (Cinnamon and Buff, or Brown).

(For the best Cock and one Pullet, Chickens of 1852.)

406. First prize, 15*s.*, William Cust Gwynne, Esq., M.D., Sandbach, Cheshire.
408. Second ditto, 10*s.*, Mr. Charles Punchard, Blunt's Hall, Haverhill, Suffolk.

Class 16.—COCHIN-CHINA (White).

(For the best Cock and three Hens of any age.)

452. First prize, 2*l.* 2*s.*, Mrs. Herbert, Powick, Worcestershire.
458. Second ditto, 1*l.* 1*s.*, Mr. George Charlton Peters, Moseley, near Birmingham.
455. Third ditto, 15*s.*, Mr. George Graham, Yardley, Worcestershire.

Class 17.—COCHIN-CHINA (White).

(For the best Cock and three Pullets, Chickens of 1852.)

465. First prize, 1*l.* 1*s.*, Mrs. Herbert, Powick, Worcestershire.
470. Second ditto, 10*s.*, Mr. George Graham, Yardley, Worcestershire.
479. Third prize, 5*s.*, Mr. James Cattell, Moseley Wake Green, near Birmingham.

The Judges cannot too strongly impress on the exhibitors of Cochinchina fowls the danger they incur of losing prizes, to which they would otherwise be entitled, by exhibiting specimens with imperfect tails.

Class 18.—MALAY.

(For the best Cock and three Hens of any age.)

482. First prize, 1*l.* 1*s.*, Mr. Charles Ballance, 5, Mount Terrace, Taunton, Somersetshire.

Second and third prizes withheld.

Class 19.—MALAY.

(For the best Cock and three Pullets, Chickens of 1852.)

489. First prize, 15*s.*, Mr. Gervase Oldham, Nether Whitacre, Warwickshire.
488. Second ditto, 10*s.*, Mr. Charles Ballance, 5, Mount Terrace, Taunton, Somersetshire.

Third prize withheld.

Class 20.—GAME FOWL (White, and Piles).

(For the best Cock and three Hens of any age.)

495. First prize, 1*l.* 1*s.*, Mr. Henry Felthouse, Tamworth.
510. Second ditto, 15*s.*, Mr. Theodore Bullock, Hawthorn House, Handsworth.
502. Third ditto, 10*s.*, Mr. J. T. Wilson, Redditch, Worcestershire.

Class 21.—GAME FOWL (White, and Piles).

(For the best Cock and three Pullets, Chickens of 1852.)

527. First prize, 15*s.*, Mr. James Hand, jun., Amington Old Hall, near Tamworth.
523. Second ditto, 10*s.*, Mrs. G. A. Wilson, Redditch, Worcestershire.
518. Third ditto, 5*s.*, Mr. Edward Lowe, Comberford Mill, near Tamworth.

Class 22.—GAME FOWL (Black-breasted, and other Reds).

(For the best Cock and three Hens of any age.)

544. First prize, 1*l.* 1*s.*, Mr. Edward Lowe, Comberford Mill, near Tamworth.
548. Second ditto, 15*s.*, Mr. Edward Glover, Olton Green, near Solihull.
560. Third ditto, 10*s.*, Mr. Benjamin Williams, Lovells, Handsworth.
The whole class commended.

Class 23.—GAME FOWL (Black-breasted, and other Reds).

(For the best Cock and three Pullets, Chickens of 1852.)

588. First prize, 15*s.*, Mr. Theodore Bullock, Hawthorn House, Handsworth.
591. Second ditto, 10*s.*, Mr. Henry Sewell, Upton-upon-Severn, Worcestershire.
596. Third ditto, 5*s.*, Mr. Thomas Roscoe, Knowsley, near Prescot.

Class 24.—GAME FOWL (Blacks, and Brassy-winged, except Greys).

(For the best Cock and three Hens of any age.)

622. First prize, 1*l.* 1*s.*, Mr. J. T. Wilson, Redditch, Worcestershire.
628. Second ditto, 15*s.*, The Reverend Charles D. Blyth, Sutton Rectory, Biggleswade.
620. Third ditto, 10*s.*, Mr. J. T. Wilson, Redditch, Worcestershire.

Class 25.—GAME FOWL (Blacks, and Brassy-winged, except Greys).

(For the best Cock and three Pullets, Chickens of 1852.)

631. First prize, 15*s.*, Mr. William Dester, Seckington.
Second and third prizes withheld.

Class 26. GAME FOWL (Duckwings, and other Greys, and Blues).

(For the best Cock and three Hens of any age.)

633. First prize, 1*l.* 1*s.*, Mr. William H. Austin, Norton, near Shiffnal, Shropshire.

642. Second ditto, 15s., Mr. Edward Lowe, Comberford Mill, near Tamworth.

646. Third ditto, 10s., Mr. John Hadwen, Kelroyd Bridge, Halifax.

Class 27.—GAME FOWL (Duckwings, and other Greys, and Blues).

(For the best Cock and three Pullets, Chickens of 1852.)

648. First prize, 15s., Isaac Avery, King's Norton, Worcestershire.

650. Second ditto, 10s., Mr. Francis Bullock, Hawthorn House, Handsworth.

655. Third ditto, 5s., Mr. William Smith, Kent House, Halifax.

Class 28.—GOLDEN-PENCILLED HAMBURGH.

(For the best Cock and three Hens of any age.)

662. First prize, 1l. 1s., Mr. John Royston Pearson, Chilwell, near Nottingham.

661. Second ditto, 15s., Mr. John Lowe, 6, Bull Ring, Birmingham.

659. Third ditto, 5s., Mr. W. B. Mapplebeck, 6, Bull Ring, Birmingham.

Class 29.—GOLDEN-PENCILLED HAMBURGH.

(For the best Cock and three Pullets, Chickens of 1852.)

668. First prize, 15s., Mr. James Oldham, Long Eaton, Derbyshire.

666. Second ditto, 10s., Mr. John Lowe, 6, Bull Ring, Birmingham.

665. Third ditto, 5s., Mr. Charles Brown, 47, Edgbaston Street, Birmingham.

Class 30.—GOLDEN-SPANGLED HAMBURGH.

(For the best Cock and three Hens of any age.)

677. First prize, 1l. 1s., Mr. Henry Clapham, Aireworth, near Keighley, Yorkshire.

680. Second ditto, 15s., Mr. James Dixon, Westbrook Place, Bradford, Yorkshire.

671. Third ditto, 5s., Mr. Thomas Smith, Brineton, near Shiffnal.

Class 31.—GOLDEN-SPANGLED HAMBURGH.

(For the best Cock and three Pullets, Chickens of 1852.)

692. First prize, 15s., Mr. Henry Clapham, Aireworth, near Keighley, Yorkshire.

686. Second ditto, 10s., Mr. Thomas Smith, Brineton, near Shiffnal.

Third prize withheld.

Class 32.—SILVER-PENCILLED HAMBURGH.

(For the best Cock and three Hens of any age.)

697. First prize, 1l. 1s., The Honourable Mrs. Astley, Swanton House, Thetford, Norfolk.

709. Second ditto, 15s., Mr. Benjamin Dain, Slade House, Aston, Birmingham.

698. Third ditto, 5s., The Right Honourable Viscount Hill, Hawkestone, Salop.

Class 33.—SILVER-PENCILLED HAMBURGH.

(For the best Cock and three Pullets, Chickens of 1852.)

743. First prize, 15s., Mr. Benjamin Dain, Slade House, Aston, Birmingham.

748. Second ditto, 10s., Mr. Thomas Lowe, Whateley, near Fazeley, Staffordshire.

740. Third ditto, 5s., Mr. David Groom, Burlish, Stourport, Worcester-shire.

Class 34.—SILVER-SPANGLED HAMBURGH.

(For the best Cock and three Hens of any age.)

783. First prize, 1l. 1s., Mr. T. B. Wright, Great Barr, Staffordshire.

780. Second ditto, 15s., Mr. A. F. Sparkes, Bridgnorth, Shropshire.

767. Third ditto, 10s., Mr. William Beach, Vine Inn, Monument Lane, Birmingham.

Class 35.—SILVER-SPANGLED HAMBURGH.

(For the best Cock and three Pullets, Chickens of 1852.)

804. First prize, 15s., Mr. James Whilock, 15, High-street, Birmingham.

787. Second ditto, 10s., Charles Robert Colville, Esq., M.P., Lullington, near Burton-upon-Trent.

816. Third ditto, 5s., Mr. Henry Clapham, Aireworth, near Keighley, Yorkshire.

Class 36.—POLAND FOWL (Black, with White Crests).

(For the best Cock and three Hens of any age.)

828. First prize, 1l. 1s., Mr. Edward Bird Guest, Ivy House, Broadwas, Worcestershire.

825. Second ditto, 15s., Mr. Edward Hewitt, Eden Cottage, Sparkbrook, Birmingham.

823. Third ditto, 10s., Mr. Edward Hewitt, Eden Cottage, Sparkbrook, Birmingham.

Class 37.—POLAND FOWL (Black, with White Crests).

(For the best Cock and three Pullets, Chickens of 1852.)

831. First prize, 15s., Miss Martha Hewitt, Eden Cottage, Sparkbrook, Birmingham.

842. Second ditto, 10s., Mr. Edward Collins, 114, Moland-street, Birmingham.

837. Third ditto, 5s., Mr. Henry Child, jun., Sherbourne Road, Balsall Heath, Birmingham.

Class 38.—POLAND FOWL (Golden, with Ruffs or Beards).

(For the best Cock and three Hens of any age.)

843. First prize, 1l. 1s., Mr. John Edwards Mapplebeck, Highgate, Birmingham.

847. Second ditto, 15s., W. G. Vivian, Esq., Singleton, Glamorganshire.

948. Third ditto, 10s., John Ault, Brailsford, near Derby.

Class 39.—POLAND FOWL (Golden, with Ruffs or Beards).

(For the best Cock and three Pullets, Chickens of 1852.)

850. First prize, 15s., Mr. Daniel J. Fleetwood, 53, Ann-street, Birmingham.

851. Second ditto, 10s., Mr. John Edwards Mapplebeck, Highgate, Birmingham.

857. Third ditto, 5s., Master Godfrey Horner, Charlotte-street, Hull.

Class 40.—POLAND FOWL (Golden, without Ruffs or Beards).

(For the best Cock and three Hens of any age.)

861. First prize, 1l. 1s., Mr. William Cox, Brailsford Hall, near Derby.

862. Second ditto, 15s., James Winter, Brailsford, Derbyshire.

858. Third ditto, 10s., Mr. William Cox, Brailsford Hall, near Derby.

Class 41.—POLAND FOWL (Golden, without Ruffs or Beards).

(For the best Cock and three Pullets, Chickens of 1852.)

863. First prize, 15s., Mr. Edward Farmer, Greet, Sparkbrook, near Birmingham.

867. Second ditto, 10s., Mr. Edward Farmer, Greet, Sparkbrook, near Birmingham.

No third prize.

Class 42.—POLAND FOWL (Silver, with Ruffs or Beards).

(For the best Cock and three Hens of any age.)

868. First prize, 1l. 1s., W. G. Vivian, Esq., Singleton, Glamorganshire.

871. Second ditto, 15s., John Ault, Brailsford, near Derby.

No third prize.

Class 43.—POLAND FOWL (Silver, with Ruffs or Beards).

(For the best Cock and three Pullets, Chickens of 1852.)

872. First prize, 15s., Mr. Daniel J. Fleetwood, 53, Ann-street, Birmingham.

874. Second ditto, 10s., Master Godfrey Horner, Charlotte-street, Hull.

873. Third ditto, 5s., John Ault, Brailsford, near Derby.

Class 44.—POLAND FOWL (Silver, without Ruffs or Beards).

(For the best Cock and three Hens of any age.)

878. First prize, 1l. 1s., Mr. Theodore Bullock, Hawthorn House, Handsworth.

876. Second ditto, 15s., Mr. Thomas Robson, Heath Hall, near Halifax.

884. Third ditto, 10s., Master Godfrey Horner, Charlotte-street, Hull.

Class 45.—POLAND FOWL (Silver, without Ruffs or Beards).

(For the best Cock and three Pullets, Chickens of 1852.)

887. First prize, 15s., Mr. Thomas Robson, Heath Hall, near Halifax.

886. Second ditto, 10s., Mr. George Parker, Perry Barr, Staffordshire.

No third prize.

Class 46.—FOR ANY OTHER DISTINCT BREED.

CUCKOO.

891. Prize, 1l. 1s., The Right Honourable Lady Guernsey, The Bury, near Leamington.

POLAND.

902. Prize, 15s., W. G. Vivian, Esq., Singleton, Glamorganshire.

RUMPLESS.

905. Prize, 15s., Mr. Thomas Beetenson, Vauxhall Grove, Birmingham.

COCHIN-CHINA.

917. Prize, 15s., John Fairlie, Esq., Cheveley Park, near Newmarket, Cambridgeshire.

923. Prize, 10s., Mr. T. B. Wright, Great Barr, Staffordshire.

FRIZZLED.

924. Prize, 15s., Mr. Theodore Bullock, Hawthorn House, Handsworth.

NEGRO, OR SILKY.

930. Prize, 1l. 1s., Mr. Jonathan Harlow, Moseley, near Birmingham.

ANDALUSIAN.

935. Prize, 15s., Mr. John Taylor, jun., Cressy House, Shepherd's Bush, London.

Class 47.—BANTAMS.

(For the best Cock and two Hens.)

GOLD-LACED.

957. First prize, 15s., Captain Clement Delves Hill, Summerhill, Newport, Shropshire.

953. Second ditto, 10s., Mrs. Hosier Williams, Eaton Mascott, near Shrewsbury.

SILVER-LACED.

983. First prize, 15s., Mr. Thomas Roscoe, Knowsley, near Prescot.

985. Second ditto, 10s., Mr. Edward Hewitt, Eden Cottage, Sparkbrook, near Birmingham.

WHITE.

996. First prize, 15s., Mr. Benjamin Dain, Slade House, Ashton, Birmingham.

994. Second ditto, 10s., Mr. Richard Bratton Baddeley, Wellington, Shropshire.

BLACK.

1005. First prize, 15s., Mr. John Dain, Henley-in-Arden.

1003. Second ditto, 10s., Mr. Matthew Ridgway, Dewsbury.

ANY OTHER VARIETY.

1017. First prize, 15s., Mr. C. Amsden, Lichfield.

No second prize.

Class 48.—PIGEONS.

CARRIER.—1019. First prize, 7s. 6d., Mr. Edward Barber, Monk's Path, Shirley Street, near Birmingham.

1024. Second ditto, 5s., Mr. Samuel Ridley, jun., Brighton.

1026. Commended, Mr. Edward Barber, Monk's Path, Shirley Street, near Birmingham.

ALMOND TUMBLER.—1033. First prize, 7s. 6d., Mr. George Parker, Perry Barr, Staffordshire.

1035. Second ditto, 5s., Mr. William Curtis, High Street, West Bromwich.

- OTHER TUMBLERS.**—1039. First prize, 7s. 6d., Mr. John Percivall, 1, Belgrave Place, Bristol Road, Birmingham.
- OWL.**—1044. First prize, 7s. 6d., Miss Sarah Mary Beetenson, Vauxhall Grove, Birmingham. 1043. Second ditto, 5s., Miss Sarah Mary Beetenson, Vauxhall Grove, Birmingham.
- NUN.**—1046. First prize, 7s. 6d., Mr. Charles Tovey, Waterloo Place, Bloomsbury, Birmingham. 1048. Second ditto, 5s., Mr. Josiah Chune, Coalbrookdale, Shropshire.
- TURBIT.**—1051. First prize, 7s. 6d., Mr. Joshua Hopkins, 39, Dale End, Birmingham.
- JACOBINE.**—1059. First prize, 7s. 6d., Mr. John Amphlet, Walsall. 1057. Second ditto, 5s., Mr. John Dugard, Finch Street, Handsworth.
- FANTAIL.**—1067. First prize, 7s. 6d., Mr. Thomas Beetenson, Vauxhall Grove, Birmingham. 1068. Second ditto, 5s., Mr. James Steen Harvey, 34, Aston Street, Birmingham.
- TRUMPETER.**—1076. First prize, 7s. 6d., Mr. Joshua Hopkins, 39, Dale End, Birmingham. 1074. Second ditto, 5s., Mr. W. H. Goddard, Hagley Road, Edgbaston.
- POUTER, OR CROPPER.**—1079. First prize, 7s. 6d., Mr. William Curtis, High Street, West Bromwich.
- BARBE.**—1083. First prize, 7s. 6d., Mr. Joshua Hopkins, 39, Dale End, Birmingham.
- RUNT.**—1089. First prize, 7s. 6d., Mr. George C. Adkins, Edgbaston. 1086. Second ditto, 5s., Mr. John Hill, Vincent Street, Balsall Heath.
- DRAGON.**—1097. First prize, 7s. 6d., Mr. Samuel Ridley, jun., Brighton. 1095. Second ditto, 5s., Mr. Edward Barber, Monk's Path, Shirley Street.
- OTHER VARIETIES.**—No prizes awarded.

Class 49.—GEESE.

1120. First prize, 1l. 1s., Mrs. H. Hill, New House, Stretton Grandison, Herefordshire. 1107. Second ditto, 10s., Mr. John Taylor, jun., Cressy House, Shepherd's Bush, London. 1119. Third ditto 5s., Thomas Townley Parker, Esq., Sutton Grange, St. Helen's, Lancashire.

Class 50.—DUCKS.

- AYLESBURY.**—1127. First prize, 1l. 1s., The Right Honourable Viscount Hill, Hawkstone, Salop. 1137. Second ditto, 10s., Miss Rachel Walker, Clipston Rectory, Northamptonshire. 1148. Third ditto, 5s., Mr. Joseph Jennens, Moseley, near Birmingham. The class generally commended.
- ROVEN.**—1167. First prize, 1l. 1s., Mr. Charles Punchard, Blunt's Hall, Haverhill, Suffolk. 1164. Second ditto, 10s., Mr. H. Worrall, Knotty Ash House, near Liverpool. No third prize.
- ANY OTHER VARIETIES.**—1172. First prize, 1l. 1s., Miss Clifton, Whittington, near Worcester. 1173. Second ditto, 10s., Sir John Cathcart, Bart., Cooper's Hill, Chertsey, Surrey. 1175. Third ditto, 5s., Mr. John Shackel, Blenheim House, Small Heath, near Birmingham.
- MUSCOVY.**—1184. Prize, 10s., Mr. Thomas Snape Tunaley, Milfield, near Tamworth.

Class 51.—TURKEYS.

1217. First prize, 1l. 1s., John Fairlie, Esq., Cheveley Park, near Newmarket, Cambridgeshire. 1211. Second ditto, 10s., Mr. William Udal, Green Lanes, near Birmingham. 1196. Third ditto, 7s. 6d., The Right Honourable the Countess Howe, Gopsall Hall. The class generally good.

Class 52.—GUINEA FOWL.

1220. First prize, 1l. 1s., Mr. William Masfen, Norton Caines, near Cannock. No second prize.

Judges of Poultry.—The Hon. and Rev. Stephen Willoughby Lawley, Escrick Rectory, near York; G. R. Andrews, Esq. Dorchester; The Rev. Robert Pulleine, the Rectory, Kirby Wiske, near Thirsk; Mr. John Baily, Mount-street, Grosvenor-square, London.

Judges of Pigeons.—Mr. T. L. Parker, Birmingham; Mr. Hale, Handsworth.

DISEASES OF POULTRY.—No. 2

BROKEN LIMBS.

In accordance with your desire, I shall be happy to investigate, as far as my opportunities will allow, the various diseases of poultry. I believe that this can only be advantageously done by a close observance of symptoms during life, and an attentive examination after death. Situated as I am, with but a small number of fowls, and those in circumstances calculated to promote health, I am not likely to have, from my own stock, many subjects for investigation; I should, therefore, feel obliged to any of your readers who would supply me with patients as soon as I can make the requisite arrangements for opening my poultry hospital. I must beg of them, however, to follow the usual course in such cases, viz., to send me a letter of introduction previously, otherwise their protégés might arrive when the wards were overflowing, and all the beds in the hospital occupied. This would be more especially requisite, as, in any contagious diseases, it would be important, in the highest degree, to keep the birds separate. Should the patients die, I should make *post mortem* examination in

every case. On the contrary, should they recover under the treatment pursued, I should be most happy to return them to their owners.

In the meantime, I may say a few words respecting the treatment of broken bones. Fractures of the bones of the body are less likely to occur in birds than in other animals, inasmuch as the framework of the body is more completely united together, and is protected from injury by the feathers. In cases where fracture of the ribs, or other bones, may be suspected, there would be great difficulty in determining the nature of the injury, and I do not think anything more could be done than keeping the bird quiet until recovery.

In cases of broken wings, the quill feathers would prevent any recourse being had to ordinary bandaging. The plan I should pursue, would be to tie carefully the ends of some of the quills together in *their natural position*, with the wing closed; this would prevent motion of the broken ends of the bones; and to keep the bird in an empty place, where there could be no perch, or other substance, for it to attempt to fly upon.

Fracture of the fleshy part of the leg would be less manageable, and I can hardly recommend any bandaging that would be readily applied. The most common fracture in fowls is that of the naked part of the leg. This is usually treated by wrapping a slip of rag round the injured limb, and tying it with thread—a very imperfect plan, as motion of the broken bones is not prevented, and which is, therefore, frequently unsuccessful in its results. I should recommend a modification of what is known to surgeons as a gum splint. Let the white of an egg be well-beaten up with a fork, and spread upon a strip of thick, soft, brown paper, as wide as can be conveniently wrapped around the broken limb. The fowl should be held by an assistant; the leg slightly stretched, so as to bring the ends of the bones in a straight line; the moistened paper should be wrapped smoothly round several times, and secured by two or three turns of thread; and, lastly, to prevent the parts being moved before the paper has become dry and stiff, a thin splint of wood, such as is used for lighting pipes, may be bound with thread on each side; the wood might be removed the following day, as it then would add only to the weight, without increasing the advantage of the contrivance, which acts by preventing all motion, and so places the limb in the best possible condition for a union to take place.

Splints of this kind are of great value in human surgery, and several modifications of them exist; they are sometimes formed of gutta percha, softened by heat, or by leather, softened by hot water, or by tow and gum, lint and starch, &c.; but I do not think any so applicable to poultry as I have recommended, as the materials are always at hand, and, what is a matter of great importance, can be applied immediately after the accident.—W. B. TEXETMEIER, *Tottenham, Middlesex.*

HARDIHOOD OF PLANTS AT CLOYNE, IN IRELAND.

MANY thanks for your information relative to *Veronica speciosa*. My plant of it is but a rooted cutting of July last; but, a fortnight since, I saw the parent plant in full luxuriance, in front of a south wall, in a garden near Kilmallock, in the county Limerick, and without any protection whatever. Is *Veronica Jacquini* delicata similarly hardy, as I have a small plant out? [*Yes*] *decussata* I know is not.

It may interest you to know what plants are still (Dec. 6th) standing in good health out-of-doors here, at least, in my small garden—*Salvia fulgens* and *Grahamii*. The *Patens*, also, has not yet died down. *Escallonia rubra*, *Lophospermum*, and *Calumbilis scabra* (the latter has borne so much seed that I would gladly exchange it with any one who wished for it); a mixed bed of *Verbenas*, principally scarlet (*Defiance*), also seem in great strength; and near them some *Alosoas* and *Cupheas*. The *Ixias* and scarlet *Gladioli* are all springing up. The *Calla Æthiopica* is in great luxuriance, from the recent rains.—REV. R. M. E.

VISITS TO SOME OF THE CHIEF POULTRY YARDS IN ENGLAND.—No. 5.

(MR. PUNCHARD'S.)

"BLUNT'S HALL," the hospitable residence of Mr. Punchard, is situated at the extreme western part of the county of Suffolk, about a mile from the little market town of Haverhill, once famed for its manufactory of checks, cottons, and fustians.

For his poultry, Mr. Punchard has two establishments, one at Blunt's Hall, and another at an off-farm, at about half-a-mile distant. The accommodation afforded the poultry in each place is much the same. Mr. Punchard confines himself entirely to two kinds, namely, Cochins, and Ducks of the Rouen and Aylesbury breed. Of the Cochins,

or Shanghaes, by which name, I suppose, we shall soon be obliged to distinguish them, he has from about five to six hundred, all of the purest breed, bred by himself, and chiefly, I believe, from imported birds. In a corner, I observed a few pairs, very recently from Shanghai, which he has not yet had time to breed from. In respect to colour, the different shades of buff very much preponderate over the brown and partridge; but, in my opinion, breeders have dwelt too much on colour, the brown and partridge being less esteemed, but, as far as my experience has led me, they are the largest birds, and produce the greatest weight of eggs.

The accompanying sketch will serve to give a pretty correct idea of the accommodation afforded by Mr. Punchard to his fowls, and may be interesting to many of the readers of *THE COTTAGE GARDENER*.

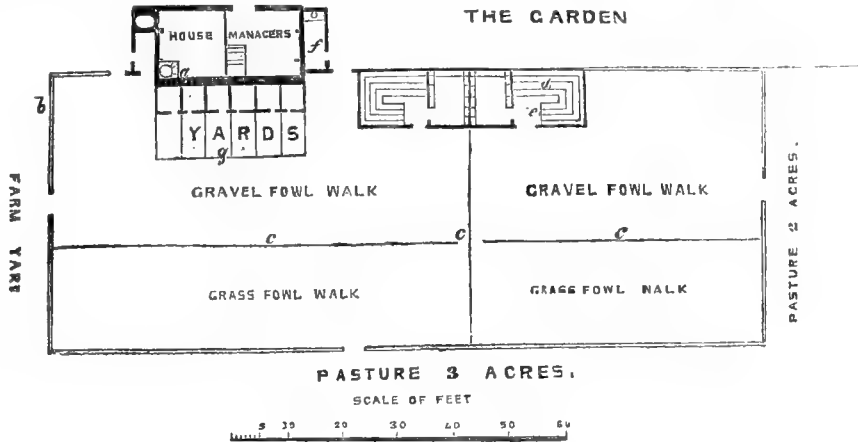

- a This copper heats the chicken houses by hot-water pipes during the winter, which can be extended to the roost and nest houses.
- b Wall four feet high.
- c Wire fence three feet high.
- d Perches arranged in a sloping form.
- e Windows running on cast-iron rollers, the openings being wired inside to admit air at pleasure.
- f Ventilators with moveable louvre boarding. A perforated zinc tube from each end of the building communicates with the ventilator and gives any degree of coolness. In winter they are closed. The roof of this building is slate nailed on boarding.
- g Space pale fencing.

As regards feeding, I observed that the fowls are never without a supply of food, which consists of a mixture of wheat, crushed barley, and peas. The feeding-troughs are upon the same principle as the hopper of a mill. The trough itself is five feet long, and three or four inches deep, and, as the fowls take the food from the trough, it is supplied from a reservoir above, which holds two or three bushels, the supply being alike on both sides, making together a length of ten feet in each feeder. Fresh water is supplied to them every morning in Bailey's registered fountains. An air of the most perfect cleanliness pervades every part of the above; the sleeping-places being cleaned out every morning, and fresh dry gravel or sand strewed upon the floors. Considering the very great attention given by Mr. Punchard in selecting his fowls for breeding, I need hardly say, that their progeny is first-rate, and that amongst the brown and partridge, as well as the buffs, there are a number of birds of exquisite symmetry and form. And in this I am borne out by the opinion of a gentleman from the west of England, who is one of our greatest amateur breeders, whom I consider myself most fortunate in meeting at Blunt's Hall. The birds, about two hundred in number, selected by Mr. Punchard for his forthcoming auction, which I hear will take place on Tuesday, the 4th of January, at Mr. Stevens's Great-room, King-street, Covent-garden, are, as a whole, a selection of a very choice and superior kind.—J. H. P.

[Another excellent judge of poultry has also favoured us with the following notes upon Mr. Punchard's poultry establishment.]

Many, in Mr. Punchard's situation, would have been content with the laurels won at Birmingham in 1850, and thought but little of acquiring other Shanghai stock beyond what had been so triumphant on that occasion. Not so with him, however; for, carrying out the true principles on which alone excellence in poultry, or any other stock, can be maintained, several importations of fresh birds from the northern parts of China have been selected for him by

intelligent correspondents, and been added to his collection at Blunt's Hall.

"An imported bird" is now a common term, especially in advertisements, to denote some specimen of new and great excellence, and of increased value. The accuracy of this we greatly doubt; for, hitherto, no recently-imported specimen has come before us equal to the occupants of many a pen at any of our recent exhibitions. Mr. Sturgeon's observations led to the same conclusions as we have ourselves formed, from what has happened in Mr. Punchard's, and some other cases. It is precisely the same with other fowls, and with Spanish, perhaps, particularly; for we know of more than one instance wherein poultry-keepers, desiring to shine with especial lustre in that beautiful class, have had large consignments from Spain, at considerable cost, without in the remotest degree increasing their chances of success. Whether Europe or Asia be their locality, the habits of poultry are identical, and mongrelism is found predominant. How zealously do we guard against it in our own well-wired yards; and how needful is our watchfulness. Thus, wherever similar precautions are altogether neglected, we must always have a large number to select from, where purity of race, and excellence in colour and form, are the objects of our ambition: and not even then must we calculate on success.

Mr. Punchard, therefore, deserves our best thanks for continuing what becomes a very expensive, however necessary a practice; for, if one bird in twelve possesses points of sufficient merit to warrant its introduction into our yard, the cost of the other eleven must be added, and this is, probably, a favourable estimate. We can only hope, therefore, that the now rapidly-increasing numbers of poultry-keepers will have the sound sense and discretion to select stocks from such a source as Mr. Punchard's, and of those other breeders who, like him, disregard cost, that the most perfect specimens of the Shanghai breed, from their native country, may gradually effect improvement in those few points, where the best English-bred birds may be

thought capable of it. If any be bold enough to say, we can have nothing better than some of those birds that have been shown in the course of the present year, we will not argue with him on what must be, as yet, an open question; but only add, that we must, for a time at least, import, that what we now have may be maintained at its present pitch of excellence, and suffer no deterioration. Some chicks of a week old had been hatched from those last imported; their downy covering varied in every tint from brown to white; and if, in spite of Mr. Punchard's care, a Suffolk winter checks their growth, they will be a useful guide for the matrimonial projects of next spring. A cock and hen were here of dark Vandyke brown, almost a self-colour, so far, at least, as we could judge, the birds being in severe moult; in lighter birds, the imported specimens, both here and elsewhere, have generally somewhat more of mottling than is commonly liked. A bamboo coop, in the corner of the yard, was their residence during the voyage; it must have been a narrow residence, and far from convenient. Importers would do well to insist on coops of sufficient height to allow the birds full room to stand upright; and the bars on which they stand should always be parallel to the front. How otherwise they escape deformity in the feet is a matter of wonder.

In one of Mr. Punchard's yards, eighty-five cockerels, in another sixty-five, produced a perfect blaze of colour, from which every tint might be selected. The birds were in admirable condition, and did full justice to the liberality that had awarded them so comfortable an abode, and so liberal a diet; but our eye searches in vain for the beautiful bird that was shown at Winchester; for his rich golden hackle, and glowing buff body colour, no less than his form and carriage, however closely imitated, is not fully attained by any of his relations now before us. We must find him, however, and Mr. Punchard kindly takes us where he appears in company with sundry brothers and cousins, each in a separate basket. Do you ask why? We will tell you. They are undergoing the penance for having appeared in public; for, however peaceable and contented their eighty-five relations may live together, whenever any of them are separated, though only for a few days, their return does not seem anyways pleasing to those who have not enjoyed the same excursion, and the admiration of the public; and this dissatisfaction is sometimes forcibly illustrated.

Mr. Punchard's name is often exclusively associated with the partridge-coloured birds that he has brought to such excellence; but, desiring to have the Shanghae race fully represented in every branch, his yard now numbers specimens of the fawn and buff birds that would do credit to the most skilful breeding. As regards the former, we might search in vain for better than those shown by Mr. Punchard at Winchester, and destined, we hope, for a similar victory at Birmingham. Mr. Punchard's arrangement of the yards and poultry is on a large scale, and most complete in all its detail; for, besides the gravelled court, each lot has the run of a young shrubbery and an acre or so of pasture. Fowls, indeed, were never better housed and cared for in all their wants. Were we lucky enough to have the same conveniences for our birds, we should make but one alteration, and that would be doing away with brick floors, which retain moisture, and consequently lower the temperature, and substitute the chalk, which is abundant in the neighbourhood. The advantage of grinding a large portion of the corn used for the fowls is here evidenced in a striking manner; and Mr. Punchard having a mill attached to his farm is, doubtless, enabled to practice such judicious economy in respect of feeding as the possession of a flock of upwards of six hundred birds must render necessary.

The aspect of the site of Mr. Punchard's different poultry yards and houses was against him; but admirably has he remedied this objection: and a Newmarket racing-stable can hardly boast of more considerations for the wants, and more caution for the health of its inmates, than are evinced in the plan and execution of his poultry buildings at Blunt's Hall.

The kindness of Mr. Punchard, in affording the fullest information on every point to all inquirers, must have led many to profit by his hospitality and experience. And as a large portion of his present stock are destined for the

auctioneer's hammer, not only those who have already seen for themselves, but poultry-keepers of every degree, will do well to take that opportunity of ascertaining how far their own favourites may be benefited by the introduction of his stock.—W.

THE BRISTOL POULTRY SHOW.

THERE are too many proofs to admit of a doubt that the public interest in Poultry is extending and increasing, and not the least of them is that the Exhibitions, hitherto confined to the north of England, almost exclusively, are now becoming general. The Bristol Agricultural Society, like many others, this year added a Poultry Show to their annual Exhibition of other Stock. The show was held on the 6th, 7th, and 8th of December, in a large and commodious room in Partwall Lane, part of the agricultural implement manufactory of Messrs. Fowler and Fry.

The number of pens entered for competition was 295; and when the excellence of many of the specimens, and the short notice given of the show, together with the fact that it precedes that at Birmingham by only one week, are taken into account, we are sure that the Committee and their excellent Secretary, Mr. Marmont, have no reason to regret the conclusion to which they came, to add this new feature to their annual exhibition. The number and respectability of the company, also, showed that they had not been mistaken in supposing that such an addition would prove attractive, and we hope it will turn out remunerative to the funds of the Society.

Our notice of each class must, of course, be short. Taking them in the order of the prize list (we hope the Committee will venture upon printing a catalogue next year), the Spanish first claim our attention, but with the exception of the pen for which the prize was adjudged to Joseph Rake, Esq., there was nothing particular to notice in this class. The Dorkings were a better class, and the pen for which the first prize was awarded to Miss Anne Wilcox were very good birds. The Cochins were the next, and decidedly the best class in the exhibition; the buff preponderating, both in number and quality, although there were two or three pens of very fine white breeds. Of this variety fifty-five pens were entered in class 3, and if we may judge from them of what is likely to be shown in the corresponding classes at Birmingham, the judges there will have no sinecure. Here, at all events, they had no easy task, and there can be no doubt that Cochins are the favourite fowl in the West of England. The first prize was awarded, after much consideration, to Mr. James Pond, of Bath, and the second and third to T. H. Potts, Esq., of Kingswood House. Several other pens were highly commended by the judges. We were sorry again to see the Malays wanting—one pen only being shown, and these not sufficiently good, in the opinion of the judges, to merit a prize. There were fourteen pens of Game Fowl, nearly all good, the principal prize being carried off by P. W. S. Miles, Esq. The Hamburgs were not particularly good as a class, but a few fair specimens were shown, and there was a good pen of Golden-headed Polands. Of the cross-breeds we will only say that we hope they will be excluded from all future shows, both of this and every other Society. The little Golden Bantams mustered strong, but we have seen better birds; while of the Silver variety not a single pen appeared. Some good white ones were exhibited, but the blacks were very poor. The Cochinchina Chickens were equally as good as the adult class, and out of eighteen pens, Mr. Punchard carried off the first and second prizes, the third falling to the share of Mr. Pond. We should ourselves be glad to see the different Societies adopt uniformly a rule, that chickens only should be shown against chickens, and old birds against old birds, and we are very sure such an arrangement would save much trouble to the judges, and render their decisions more satisfactory to themselves and to the public. There was a class here for "any breed," in which Mr. Potts was again successful in winning a first prize for a nice uniform pen of young Cochinchina Chickens. The Geese were but middling. The Turkeys better; and the Ducks, in which latter class Miss Wilcox was again the winner, good. The Pigeons, also, were choice, but few; and a pair of fowl marked "Ceylon Jungle," were quite new to us, and very pretty, as well as very distinct.

We are not aware that the other classes require any special notice, but we cannot conclude without adding a hope that the success of the Exhibition, as a whole, and the interest which it evidently excited, will induce the Committee to repeat it in subsequent years, and that they will (as, indeed, they begun this year by doing) take care to avoid the very objectionable practice of appointing dealers to be judges. Upon this occasion, that not very enviable office was filled by Mr. Bissell, of Birmingham, and Mr. Bond, of Leeds. The prize list was as follows:—

Class 1.—SPANISH.

First Prize to Joseph Rake, Esq. No other prize awarded.

Class 2.—DORKINGS.

First Prize to Mrs. Anne Wilcox. Second, Mrs. Neville.

Class 3.—COCHINS.

First Prize, Mr. James Pond. Second and Third, T. H. Potts, Esq. The judges highly commended pens belonging to Joseph Rake, Esq.; John R. Rodhard, Esq.; William Plummer, Esq.; Mr. C. Punchedard, and John Abraham, Esq.; and commended pens shown by Henry L. Bean Esq.; T. H. Potts, Esq., and Mr. James Pond.

Class 5.—GAME.

First Prize, P. W. S. Miles, Esq. Second, Mr. Thomas Smith.

Class 6.—PENCILLED HAMBURGH.

We omitted to note the prizes in this class.

Class 7.—SPANGLED HAMBURGH.

First Prize, Charles Greig, Esq. Second, Mr. Charles Edwards.

Class 8.—POLANDS.

First Prize, R. L. Bush, Esq. Second, Mr. C. J. Kenning.

Class 9.—CROSS BREED.

First Prize, Mr. James Pond. Second, Mr. John Brackenridge. Third, Mr. Henry S. Pigott.

Class 10.—CUCKOO.

No First Prize. Second, John Bumble.

Class 11.—GOLD AND SILVER BANTAMS.

First Prize, Mr. John R. Rodband. Second, Mr. Thomas Canning.

Class 12.—WHITE BANTAMS.

First Prize, Mr. G. T. Hodson. Second, Mr. Henry L. Bean. Highly commended, Mr. G. T. Hodson. Commended, Mr. John R. Rodband.

Class 14.—COCHIN CHICKENS.

First and Second Prizes, Mr. Charles Punchedard. Third, Mr. James Pond. Commended, Brooke Smith, Esq. (two pens). Highly commended, G. C. Atkins, Esq.

Class 15.—ANY BREED.

First Prize, Mr. Thomas Potts. Second, Mr. Joseph Rake.

Class 16.—TURKEYS.

First Prize, Mr. John Hill. Second, J. R. Rodbard, Esq. Third, Dr. Washbrough.

Class 17.—GEESE.

First Prize, Henry Orum.

Class 18.—DUCKS.

First Prize, Miss Wilcox, (Aylesbury). Second, John Miles, Esq., (Aylesbury). Third, Mr. C. Punchedard (Rouen).

Class 19.—GUINEA FOWL.

First Prize, John R. Rodbard, Esq. Second, Daniel Burgess, jun., Esq.

Class 20.—PIGEONS.

Carriers, Mr. William Martin (the whole class commended). Classes, 21, Antwerps; 22, Barbs; 23, Croppers; 24, Runts; 25, Fantails; 26, Jacobins; 27, Turbets; 28, Nuns; 29, Archangels; 30, Trumpeters; 31, Almond Tumblers, all to G. C. Atkins, Esq., whose birds were beautiful, and shown in excellent condition.

TO CORRESPONDENTS.

HITCHIN POULTRY SHOW.—When we first glanced over a letter addressed to us by *One of the Committee of the Hitchin Poultry Show*, replying to our comment on such shows being held for the benefit of inn-keepers, we did not observe this postscript—"Is it possible you are a disappointed exhibitor?" We pass over the impertinence of this to reply, though scarcely necessary, that we did not exhibit directly or indirectly at Hitchin. Let us add, for the improvement of our correspondent's self-knowledge, that he who is hasty in attributing an ill-motive to another, should examine closely whether he himself would be actuated by the evil he suspects. The other portions of the letter, written temperately enough, leave our opinion unaltered—that no Poultry Show, should, if avoidable, be held in connection with an inn. The reasons against it are too numerous, and too apparent, to need detailing; and we are too anxious for the success of all Poultry Shows not to point out whatever we consider prejudicial to them.

PREVENTING A HEN SITTING.—"As a breeder of Cochins, I have been plagued by their propensity to sit; and I have found the following very good plans for breaking them of that propensity, which, as at this time of the year parties do not want sitting-hens, may be useful to some of your readers. The first way is, when you notice them at all getting broody, which is easily told by their staying longer than usual on the nest when laying, and the quarrelsome disposition they acquire just at that time,

to remove them to another walk, or put them in a coop, and, if possible, let them be removed before they have laid their last egg, or got fond of the nest, and in a few days they will have settled down, and the inclination to sit have gone off. The other plan is, instead of letting them sit on an empty nest for three weeks, and in two cases out of three finding them as bad to break of sitting as they were the first day, if not worse, let them have two or three good eggs to sit upon; they then hatch a chick or two, and they will naturally, in a day or two after hatching, leave the nest with the chickens; let them have them a day or two to roam about with, then take them away. The hen, in a few hours, will forget her offspring, and with them her inclination to sit. The chickens, if three or four lots, may be given to one hen, or disposed of in any other way parties may think proper."—T. B. STEAD.

ORCHID-CULTURE (W. S.).—All orchids should go to rest when they have completed their growth. Your *Oncidium papilio* may continue blooming. Do not, at any time, cut down the flowering-stem till it dies naturally. Your *Aerides odoratu*, a foot high, will most likely bloom next year; it is evergreen. *Zygopetalum Mackayi*, just blooming, must have a little water, and be kept growing. It is a winter-blooming species. *Dendrobium nobile*, two feet high, if the shoots are strong and well-ripened, should flower next year; let it now go to rest. It partially loses its leaves; let it remain in the present pot till it begins to grow. The *Aerides* would do best in a rough basket, filled with sphagnum moss only, and hung up to the rafter, about three feet from the glass. The heat you give them is quite right. Your *Cattleya mossia* is evergreen, and should be grown at the coldest end of your house; let it remain in its present pot till spring. Orchids will do in a mixed plant stove, but should be placed at one end, where they can have the proper treatment. See THE COTTAGE GARDENER for 1850 and 1851, for full information on Orchid-culture.

SPECIMEN PLANTS FOR A GREEN BANK (Mrs. C.).—We think we have seen the very banks you mention, and the waters also, but it was "long ago." More recently, we had some delightful rambles along these rivers with the late Sir Thomas Dick Lauder, in his last efforts at painting the beautiful scenery in those parts. On the highest part of the banks we would plant a group of three or four Venetian Sumachs (*Rhus cotinus*), about four feet apart each way; and in four years they will look as one, and "make one grand specimen," as the gardener says. The flowers are charming, and they hold on a long time; but this is not an evergreen. The trees you mention—*Pinus insignis*, *Abies Douglassii*, and *Cupressus funebris*, or Chinese Cypress, as you call it—you will, probably, have to send to Edinburgh for. For such sized plants as would suit you, about 5s. each would be a fair price. The Sumachs at 1s. would do. If you have room enough, you ought to have a *Dendur* at 6s.; an *Auracaria imbricata*, about the same; and *Cupressus macrocarpa* and *C. Goveniana*, for 5s. or 6s. the two; and see you allow them as much room as you can spare, and do not plant them too near to the house.

WHEAT DIBBLER.—We have been favoured with the following replies:—"In answer to 'T. R. N.,' the best dibbles for making the holes and delivering the seed at the sowing-time is Newberry's (Newington's?). The construction of this machine is perfectly beautiful, and wonderfully effective. It may be had for one, two, three, four, or five rows, and will sow a proportionate number of acres in the day. It delivers from one to three, and sometimes five, grains in each hole, at the rate, the *abundant rate*, of one bushel to the acre. The crop looks in March like a field of green shaving-brushes: such beautiful tufts of plants so equally distributed. Upon land well-drained, fallowed, and enriched, six quarters per acre may be calculated upon. The sowing should take place on the furrow-slice, just mellow, but not too free, or at all harrowed, lest the holes be stopped by the adhesion of the soil. We speak of that we know; for we have not only heard of, or seen, but possessed, used, and felt the benefit of this dibble. The seed time should be rather early, as this deep depository does not admit of the plant coming up so rapidly as in shallow sowing. The pressed *nidus* for the seed gives admirable ground-hold to the plants. It has been objected, that the seed-hole forms a dangerous cup for the detention of water. We can only hope that land will be generally drained, when this objection will not lie, or be mentioned. It is a wonderful invention which can render undrained land worse than it is, especially for wheat.—T. BETA." A *Florist* says:—"I see your correspondent, 'J. R. N.,' wishes to know which is the best 'wheat-dibbling machine.' I believe the one invented by Mr. Gillam, of the Bear Hotel, Woodstock, Oxon, is the best. You will find it in the Exhibition catalogue; and I believe it is there recommended, and I know it to be used by many persons around here (Oxford); but by writing to Mr. Gillam, I have no doubt he will send him every information."

GRAPE-GROWING.—Mr. W. Dobson says:—"I have frequently been asked where the best forced grapes grew, that is, within three or four miles of any large town in England? I have been at most of the places round the largest towns in England. My opinion is, that the best grapes are near the town of Leeds, in Yorkshire, where I am staying at the present time. The best near Leeds, last autumn, were in the following gentlemen's gardens, which, I think, could not be beaten near any other town—Sir G. Goodman, M.P., Mrs. Benyon, G. O. March, Esq., —Donesthorp, Esq., John Wilkinson, Esq. These are all near Leeds, and nearly all single-handed places, but far too much work for one man. If Mr. March's gardener would send you a few lines stating how he manages to grow both Peaches and Grapes together, it would be useful to the readers of THE COTTAGE GARDENER, for those fruits are managed in a first-rate manner." It is very difficult to grow Grapes and Peaches in the same house; and if Mr. March's gardener will favour us with his mode of treatment, he will oblige us and many of our readers.

WORKS ON PEACH AND STRAWBERRY (C. Jones).—You will find these in "The Gardeners' Monthly Volume," and they may be had of Mr. Bohn, Bookseller, London.

WHOSE SHANGHAE FOWLS ARE UNRELATED? (H.).—You are quite right in being anxious to breed from birds not of the same strain; and you are equally correct in saying it is difficult to know which are not so. All that you can do is to inquire of the sellers what is the parentage of their birds, and regulate your purchases accordingly. It is quite true, as you state, that Mr. Punchedard had his stock originally from Mr. Sturgeon, but they are quite a distinct strain, and both of them have added

imported birds to their stock, so as to have quite distinct blood. The same observation applies to our own, and many other breeders of Shanghai Fowls; their stocks originally came from some well-known yards, but have been mingled with imported birds, so as to have chickens of a strain that might be coupled, unobjectionably, with chickens from the original stock.

VINERY (*An old Subscriber*).—Sanders's *Treatise on the Culture of the Vine* will, perhaps, suit you.

WOODLARK (*Delitick*).—A warm greenhouse would not suit this bird.

DORKING COCK (*Curalonluch*).—We cannot give you the information. Put in a short advertisement, and you will have abundance of answers.

DAMP-WALLS (*M. S.*).—To prevent damp penetrating, if the smell be not objectionable, paint them over thickly with coal-tar, and dust quicklime thickly upon it. It will form an asphaltic covering.

ROSE-TREE LABELS (*Zero*).—Mr. Ivison obligingly informs us, that the labels you admired at Syon House Gardens, were made by Messrs. Morrells, 149, Fleet-street, London.

HARDENBERGIA MONOPHYLLA (*Evergreen*).—As the young growth is green and healthy you have no reason to be alarmed, though numbers of the old leaves turn pale and fall off. This is just the method that nature takes to relieve herself from useless appendages in the case of evergreen and semi-evergreen plants. When this, in the case of the *Hardenbergia*, takes place to an undue excess, it is generally attributable to dryness at the roots, a sour soil, owing to want of drainage, or a low, foggy temperature. The weather has not been so cold as to demand much fire on that account; but it has been so dull and misty, that a sharp fire in the morning would do great good by creating a rapid circulation of air. Our impression is, that you will find your plant all right, and very beautiful a few months after this.

WINTERING PLANTS.—*An Amateur Geranium-grower*, having a deep wooden frame, surrounded by a wall of turves, with wood platform to keep the plants near the glass, asks—"Can I keep Geraniums, Fuchsias, Calceolarias, Verbenas, and Auriculas, over the winter, by throwing a strong, double mat over the glass at night, and giving air at back in fine days? will extra heat be necessary, or will that of oil lamps do?" See Mr. Fish's article of last week, and somewhat similar ones of last year. Your platform for the plants, and a turf wall round the boards, are capital: could you not make the latter waterproof? Your double mats will be quite sufficient for moderate frosts; but if your plants have been growing, or there is likely to be a frost above 7° or 8°, you would require to place some non-conducting material, such as hay or straw, between them. If you would study neatness, and your own personal comfort, have a waterproofed covering. A few large earthenware bottles, filled with hot water, would be the simplest mode of communicating heat; but if your object is merely to preserve the plants during the winter, the bottles will not be so useful for communicating heat as in causing a circulation of air in muggy weather. In such a pit as yours, it is always advisable to have a bundle of dry litter ready to throw over the glass in any sudden emergency. We think we have previously told how a nurseryman, with a small supply of litter, saved his pits of Mignonette, while most of his neighbours lost their stock. During the whole night, he moved, and shook, and turned the scanty litter. He knew all about the radiation of heat.

FLOWER-GARDENS (*S. S.*).—Your own planting will be noticed when the plan is engraved. (*Caen*).—You mistook the thing altogether, and broke the rules throughout. We plant, or, rather, suggest the planting of such plans as we publish monthly; but we only criticize, or give opinions on the planting of such other plans as are sent to us. The same reply applies to *O. J. B.*, and we must keep to our rules.

MELON SEED (*Verax*).—Any age above four years does not improve Melon seeds, and might be injurious to some varieties; but there have been no direct experiments we know of to prove this.

CUTTING-DOWN LAURELS (*Ibid*).—Whoever said that Laurels cut between November and May would get their young shoots destroyed by frost must have been dreaming. Such Laurels do not make young shoots so early, by some weeks, as Laurels not touched. Laurels cut hard-in in March have not the slightest advantage over Laurels cut any day from the end of September to the 1st of May. We have done it, or helped to do it, all these months for many years; and if we were to begin life to-morrow as a Laurel-planter or grower, we would cut down our Laurels any time during the rest season that suited our convenience. The *Laurustinus* is not a Laurel, but a Viburnum, and, on account of its flowering, is seldom cut till late in May; but it, also, and all our hardy evergreens, may be cut any day during the winter. There has been more than philosophy about them for ages, which wants reconsidering.

BANKS OF A RIVER (*R. J. L.*).—Were it not for the overflowing of the river, all the herbaceous plants that would grow in your garden, or in your neighbouring wood, would do on these banks, notwithstanding water does stand at eighteen inches from the surface. *Epilobiums*, *Lythrum*, *Calltha palustris*, Single and Double *Trollius*, *Pæonies*, most of the hardy *Lilies*, and such things will answer. Then, as to shrubs, Cut-leaved *Alders*, almost all the *Willows* and *Poplars*, with the whole breed of *Magnolias*, and most *Rhododendrons*, deciduous *Cypress*, *Snow-drop-tree*, *Box-tree*, *Aucuba*, and common *Laurel*, will do.

UNPRUNED GERANIUMS (*Fiddlestick*).—Your Geraniums were neglected to be cut down at the proper time, and are now offering to make bottom shoots. Let them be as they are to the end of January, then cut them down to their bottom eyes, and about the middle or end of February shake one half of the ball from the roots, no more, and put them in the same pots, with a little rich soil all round; a month after that give them a good shift, and you never had better bloom or finer plants than you will have next summer; that is, because you never had a good bloom of them before: those who neglect to cut them at the right time never do.

MUSHROOMS (*E. S.*).—We have never seen nor heard of raising Mushrooms artificially on lawns, or grass fields, but we have seen fine crops of Mushrooms come up between rows of potatoes, from using old dung from spent mushroom beds to enrich the ground. We have also seen similar crops from spawning at the time of planting the potatoes. You might easily, and at very little expense, inoculate your lawn with some best spawn, and be the first to prove the experiment. Spawn your grass next May; and in August, if the weather is dry, give them a heavy watering

once a week, and let us know the result. If you have access to old mushroom beds, you might dress your lawn next February, March, or April, with half spent dung and half coal-ashes, and that might impregnate the turf with spawn. But you probably know as much about the subject as any one else.

SHADED BORDER (*R. A.*).—Trench it three feet deep, and to within one foot of the stems of the Laurels; then plant a row of White Lilies (*Lilium candidum*) at thirty inches from the hedge; and then a row of all the kinds of herbaceous *Pæonies* you can get, and here and there in the row, a patch of *Crown Imperials* in variety. In front of that, all the *Narcissus*, and there are upwards of 200 kinds of them—*Snowflakes*, *Leucojums*, a few *Ornithogalums*, and, indeed, any hardy bulbs that will grow to a foot or two feet high; and next the edge, *Crocuses*; nine inches from it, and in front of them, a row of *Snowdrops*, or *Winter Aconite*. Then each season cut down behind the White Lilies as deep as you trenched, to get rid of the Laurel roots.

PYRETHRUMS AND RASPBERRIES (*M. F.*).—You do not say which of the *Pyrethrums* your *Fever-few* is. We suppose of the old double-white. If so, cut it nearly down, and do not disturb yourself farther about it, unless it be a tender kind. These things will go on for years. For your *Raspberries*, throw up beds above the level, and introduce both decayed vegetable matter, of any kind, and sand liberally, securing them that depth above ground that ought not to be obtained below. *Raspberries* detest slow-acting mediums. As to your *Apricots*, "the knowledge of disease being half the cure," we cannot divine anything, as we do not know what may be the conditions.

DISEASED APRICOT (*Topiarius*).—Your Apricot, with one branch shrivelled, is probably rooted deep in an ungenial soil. We would take it up, make a platform, and replant it in sound turfy-loam.

LEGS OF SHANGHAI FOWLS (*A. W. C., Norwood*).—The colour of the legs of these birds is a pale yellow; a little pink down the sides of the legs, and where the scales of the legs and feet are thinnest, is not objectionable.

RAPE AND LNSEED DUST (*Veto*).—If we had this "at command," we should boil it in water, and try it with the meal we give our fowls. We should not buy it for such a purpose, because we do not know what its effect upon poultry may be.

PLANTING FRUIT-TREES (*A Subscriber from the First*).—As your trees are either on a hill, or on the side of a steep slope, let them remain, but have your soil well-drained.

POTATO AND CARROT FAILURE (*Edmund*).—It is very probable that the cause of the two failures was an over-rich soil and a bad season. Trench your ground; plant in February the earliest ripening potato you can obtain, and sow in April Short Horn Carrots, and you will, probably, have better success. A four-gallon stone bottle, filled with boiling water as often as it becomes nearly cold, will keep the frost out of your little greenhouse.

ESPALIER RAIL (*W. Salcombe*).—Having a bar along the top is not at all a novel suggestion. They are made so very commonly both in iron and wood. The suggestion that insects are the cause of the *Potato Murra* was made by Mr. Smee, in 1846, and the suggestion has been repeatedly shewn to be erroneous.

F. W. S.—Your plant is *Diplacus glutinosus*, or Clammy *Diplacus*. **DECAY OF CELERY** (*Ibid*).—The cause of the decay is not from being planted in beds, or so close to each other, but from ripeness, or being too much earthed-up at the last time performing this work; and the soil being heavy, with too much wet. Ripeness, we should say, for certain is the very cause of decay. If you will read Mr. Robson's explanations upon this matter, at page 185, you will find all you desire upon this point.

CLIANTHUS PUNICEUS, BRUGMANSIA, VERONICA SPECIOSA (*A Two Year's Subscriber*).—Neither of the three plants we should call good plants for a warm sitting-room; the fine green foliage of the *Veronica speciosa* makes it the best of them, as this can be placed out-of-doors on a showery day, should its leaves be dusty, and it can be taken in again in the evening as clean as ever; besides which, it will endure for years to be pinched up in a small pot, and kept alive with a little water occasionally. The *Clianthus puniceus*, of which you have enclosed a leaf, appears to be eaten up with the red-spider, which this plant is very subject to. It is a half-hardy, rampant-growing plant, where it has room, light, and air to go a-head. In your sitting-room it must be a prisoner for want of light and air. It does best when planted out in some large conservatory, either for training up a pillar or rafter. There it is at home, but it will almost do out under a warm wall with a little winter protection. The *Brugmansia*, or, as it is called, *Datura*, is an odd clumsy-looking plant for a close warm sitting-room. It is true that this is not the season for this to be looking gaily. We should be careful not to over-water it. Like the preceding, it needs more light and air.

CUCUMBER FORCING (*G. B. C.*).—Cucumbers in the middle of March, or sooner, may be had where a well-regulated heating apparatus exists, and your pit seems very well adapted for that, provided you can command the necessary amount of heat, both bottom and top. The latter, being easiest attained, must not be allowed to range above 70° for cucumbers, and a certain amount of humidity given to it by placing vessels of water in such a way as to intercept the currents of dry heated air on its way into the pit or house; or, if the pipes be open and exposed, vessels standing on them will easily effect that object. In raising cucumber or melon plants, a rather brisk bottom-heat is required, and that not too drying nor yet too humid: at the early period required for the fruit-plants you had better plunge your pots containing the seeds in some fermenting heap, and, just as the cotyledons are breaking through the soil, remove them to your pit, where the atmosphere is more pure; a little contrivance will enable you to give them all the available bottom-heat, about 80° or 85° not being too much—even 90° will do no harm, provided other things are favourable. Melon plants, to plant in your pit in May, may be reared in a dung frame prior to that time very easily; or they may be brought forward with the cucumbers, as at that period the seed vegetates, and the plants grow with less trouble than earlier.

WEEKLY CALENDAR.

M D	W D	DEC. 30, 1852.—JAN. 5, 1853.	WEATHER NEAR LONDON IN 1851.				Sun Rises.	Sun Sets.	Moon R. & S.	Moon's Age.	Clock aft. Sun.	Day of Year.
			Barometer.	Thermo.	Wind.	Rain in In.						
30	TH	Snowdrop flowers.	30.488—30.398	40—21	S.W.	—	9 a. 8	57 a. 3	8 19	19	3 1	365
31	F	Winter Tortoise Moth found.	30.262—30.044	36—28	S.W.	—	9	58	9 37	20	3 30	366
1	S	CIRCUMCISION.	29.956—29.789	35—21	W.	—	8	1V	10 a 56	21	3 59	1
2	SUN	2 SUNDAY AFTER CHRISTMAS.	29.694—29.637	41—26	S.W.	—	8	0	morn.	☾	4 27	2
8	M	Agonum vaporariorum.	29.746—29.512	49—38	S.W.	02	8	2	0 16	23	4 54	3
4	TU	Sphodrus planus; cellars.	30.122—29.539	44—20	N.W.	01	8	3	1 36	24	5 22	4
5	W	Dromius rufescens; bark.	30.098—30.064	45—29	S.W.	—	8	4	3 0	25	5 49	5

METEOROLOGY OF THE WEEK.—At Chiswick, from observations during the last twenty-five years, the average highest and lowest temperatures of these days are 42.5° and 31.4° respectively. The greatest heat, 56°, occurred on the 30th in 1833; and the lowest cold, 12°, on the 3rd in 1827. During the period 107 days were fine, and on 68 rain fell.

THE IMPERIAL PAULOWNIA.

(*Paulownia imperialis.*)



This large-leaved tree is now well known in our gardens, and is hardy in the southern districts of England. It was first discovered by Thunberg, in Japan, where it rises to thirty or forty feet; he named it *Bignonia tomentosa*, but it does not belong to Bignoniads, as is currently believed, and as we shall presently show. Dr. Siebold was the next European traveller who found it, and brought home specimens of it, from which it was described by him and Professor Zuccarini, in their "Flora Japonica," and the name they gave, and which it retains, is in honour of the name of the Hereditary Princess of the Netherlands, who was daughter to the Emperor of Russia. It was first raised from seeds, in the Garden of Plants, in Paris, in 1834, by M. Neuman, who received them "from a person to whom they had been sent from Japan in little porcelain pots." Out of this consignment only one seed vegetated, and the plant received greenhouse treatment at first, as did the first Larch-trees that were introduced into Scotland, by the Duke of Athol. As late as 1840, M. Neuman could not determine whether or not his seedling from the porcelain pot was the same as the plant represented in the "Flora Japonica," and there was not a second plant of it then known to be in Europe. So that Dr. Siebold was not he who first introduced *Paulownia*, as is generally supposed.

When the tree seeded at Paris, in 1842-3, it was discovered, from the nature and formation of the seed, that the tree belongs to the Figworts (Scrophulariaceæ), and not to Bignoniads, to which it is still referred by some writers. The error is easily accounted for, from the fact, that there is

nothing to distinguish the one from the other in the formation of the flowers. The real difference in the kindred orders being found in the seeds. Thus, the popular English name of *Foxglove-tree* is botanically correct, in addition to the good idea it gives of the flowers which are produced from the end of the branches in close panicles or thyrses. They are as wide in the mouth, but not quite so long as those of the Foxglove, and of a greyish-violet colour, with an agreeable fragrance. The nearest affinity of *Paulownia* is with the *Wightia* of Dr. Wallich, in the same section of Figworts as the Pentstemon. The *Paulownia* was first figured in this country, in 1841, in Mrs. Loudon's *Ladies' Magazine of Gardening*. It was well represented in *Paxton's Magazine of Botany*, in 1842, but the first from English-born flowers is in the *Botanical Magazine*, t. 4666. In 1843, it flowered for the first time in England, in the greenhouse of Mrs. Wray, of Cheltenham, who sent specimens of them to the writer. But it was at Claremont, we believe, that it first flowered in the open air. In the system of Linneus it belongs to the second order of the fourteenth class, *Didymia Angiosperma*.

The Bishop of Exeter, in whose grounds at Bishopstowe, near Torquay, it has bloomed, describes the fragrance as "violet-like," but that the tree, as in the *Glycine*, loses much of its beauty by producing its flowers before its leaves.

B. J.

Propagation and Culture.—This fine tree is just as easily increased as are potatoes; and something in the same way, by thick slices, or short pieces of the roots, without the trouble of looking for eyes; and they will grow in any kind of earth, from stiff hard clay to the poorest sandy soil. While it is in a young, small state it is very liable to be much cut by frost: hence the reason why we see so few of them grown as fine standards, with ten feet or more of clear, straight stem; although it may be made to make a growth of ten feet in one season. An English gentleman, writing from Paris, in 1841, said that he had seen a growth of it made that season to the extent of fourteen feet; and from him I had the first plant of it. If any one wishes to have this tree as a low spreading bush, he has only to plant a small specimen in good rich soil and let it take its chance. It is naturally of a very spreading habit, and will extend a long way, carrying immense leaves; and I fear that is all that it is good for in most parts of this country. At any rate, give it the same treatment as Rhubarb, planting it in low sheltered situations, and cut it down to the ground the first two years, and it will produce leaves quite as large as an ordinary rhubarb leaf. That is just how I would manage it for a small garden. But for a standard, I would endeavour to get a good clean stem as long as possible before I would allow it to spread. The quickest way to get such a tree would be to begin with a strong plant from a nursery, to plant it late in April, in a sheltered, warm place, near a wall or building, and in a pit filled with the richest stuff or compost about a garden; to let it grow there three years, but for the first two years to cut it down clean to the ground before the frost, and in the third season to confine the growth to one stem, and not to let that stem branch; then, before the frost, to tie this growth up to a strong pole, and to thatch it with straw for that winter. Next spring, remove it to a dry, poor soil, and open situation. D. BEATON.

SHOULD it be proved, by further and more accurate experiments, that if the leaves of root-crops are cut off before those roots have arrived at maturity, and that, notwithstanding such removal of the leaves, the roots will go on increasing in size and nutritious constituents equally with other roots of the same crop from which the leaves have not been cut off, then will a heavy blow have fallen upon some of the opinions hitherto maintained by vegetable physiologists. It will be a heavier blow to those opinions than to the botanist, this discovery of the transmutation of *Ægilops* into Wheat, for it comes upon us like a thunder-clap, and is in direct opposition to laws which we have been compelled to live under now nearly fifty years; whereas, every schedule and clause of the law of sports and crossings have been critically canvassed over and over again, and even pushed much farther than M. Fabre has done, but without actual proofs, like his.

Two specimens of the Swedish Turnip were on the table at the Horticultural Society's last meeting, not quite so purple, perhaps, as Mr. Skirving's variety, but as fine specimens of size and texture as ever. Mr. Skirving exhibited in London. The whole tops of them were cut off down to the quick last September, and the wounds were now healed over; these turnips, therefore, could never push another leaf from the crown; but several eyes below the crown pushed and made a few leaves. They were not of a size, however, to give any support to the bulb; they were rather sprouts, sucking from, rather than adding substance to the bulb, according to our present ideas. That part of the lecture which referred to this fact was listened to with intense interest. It began by telling us that the Rev. Mr. Smith, author of "A Word in Season," was a scientific farmer; that his land was stiff, and not well-suited for experiments; but that by striking at the roots of popular notions, and following out notions of his own, results were obtained as far beyond present opinions as his plans were different from common practice; that his turnips, last year, after cutting the tops off as early as the tops of the two before us were cut, the yield was twenty-seven tons to the acre; that he could not get on the land this autumn to ascertain, by actual weighing, the positive weight of the present crop, but that he guessed it run from twenty to twenty-four tons per acre; that these turnips are in drills five feet apart, and a crop of early potatoes was got from the intermediate spaces before the leaves of the turnips spread out to cover the ground; that after lifting the potatoes, the middle spaces were deeply trenched, but only taking a small quantity of the new-broken ground to the surface; and, lastly, that before the leaves met and got crowded over the trenched parts they were cut for a green crop, and that the cutting of them did not hinder the turnip from swelling and getting heavier.

After the meeting, the philosophy of all this was canvassed, and the question was asked—Why should the skin of a turnip, exposed to the full influence of the sun and air, at a certain age, not be able to assist and finish the growth, seeing that an apple,

or a gourd, has to do as much? Why not, indeed! You seldom read or hear of an experiment or invention without its suggesting another. And why should we not have under-ground turnips, like carrots and parsnips, to get rid of the "strong, turnipy flavour" peculiar to the garden turnip? The "disposition" to sport in this direction has often cost the farmer more than his share of the "burden" of this heavy country: we allude to the "bunch of keys," the "fingers and toes," and the "forks and tails," into which the turnip "runs" every year.

We must declare our opinion, however, that, at present, the experiments of the Rev. Mr. Smith, and of others, do not prove that turnip bulbs will increase in size and nutritious constituents after their leaves have been cut off. They prove no more than that the leaves may be so cut off at the concluding time of their growth, and that the bulbs remain well-preserved in the soil. Now, did we not know all this before? Have not gardeners, for years past, cut their carrots and parsnips down into the quick, and found that they were preserved better than by any other mode?

It is quite true that fruits will improve in colour and flavour after they have been gathered, but they must have attained their full growth previously; and certainly, after being so gathered, they never increase in weight, nor even if left on the parent plant after this is denuded of leaves. Again, if a Peach, or other fruit, is on a branch from which all the leaves fall off beyond it, that fruit remains stunted and deficient in flavour, or perishes entirely.

In conclusion, we advise our readers to suspend their judgments until experiments more numerous and much more accurate have been tried. Let us have rows with their tops cut off alternating with rows from which the tops are not cut off. Let us have some of the tops cut off at the end of August, and some early in September, *before* the bulbs have completed their growth in size. If in such cases the bulbs go on not only to increase in size, but to increase in nutritious constituents also, as much as do those on which the usual amount of leaves have been left, then will it have been proved that leaves are not essential for bulbs in the concluding stage of their growth; and gardeners, in future, gratifying their praiseworthy love of neatness, probably may cut off the leaves of Crocuses, Tulips, and the like, when their bloom is over, without heeding the warnings of physiologists and "such small kine."

COVENT GARDEN.

ON the morning of Tuesday, the 21st inst., at an hour when half the population of this northern hemisphere were comfortably wrapt in the arms of sleep, we were wending our way to Covent Garden Market. It was an early hour; such an one as, fortunately, we have little experience of in this dark, humid season; but, being anxious to furnish our readers with some account of this great mart during Christmas week, we encountered the difficulties of the undertaking, and after a walk of

some three miles, we reached the place about half-past four or five o'clock. It is curious to traverse the roads and streets of London at this early hour. Where, twelve hours before, all was life and bustle, din and noise, now a calm, still, sepulchral gloom pervades the whole. But as we draw nearer our object of attraction, we hear and see approaching signs of life and activity, which gradually increase till we find ourselves in a perfect bee-hive of hum and industry. Every approach to the market is literally stemmed with waggons, carts, vans, donkey trucks, wheelbarrows, and every description of wheeled vehicle it is possible to think of. These are being laden with the market produce, to be again conveyed to the shops of town and suburbs. For many miles some of these vehicles have travelled to be there at the market hour; some even far in the country, where the very vegetables were grown they have come to purchase; for, as the gardeners never sell anything elsewhere than in the public market, a neighbouring greengrocer may have to repair some miles to Covent Garden to purchase the cabbages he has watched growing from the windows of his own house.

Having now made our way right into the centre of the throng, the sound that met our ears was "Misle, Misle, Misle-to-o-o-oe!" "Holly, Holly, Holly-o-o-o!" shouted in a noisy bawl, which terminated something in the way of what musicians would call a *soprano* part, but certainly far from musical. There were many waggon-loads of both. The former chiefly from Gloucestershire and Bucks, and the latter from Surrey, and the suburbs of London. As regarded the Mistletoe, we had no doubt the former proprietors of it were right glad to get rid of it; but the Holly called up other thoughts and recollections, and carried us back to six years ago, when spending a few days in the country during the Christmas week, we looked out one morning and saw two handsome hollies, each twenty-five feet high, completely bare, with no vestige of leaf or berry, except a sort of mop which had been left on the top. The evening before, when we last saw them, they were the handsomest pair in all the country for many miles round, feathered to the very ground, and rising straight as an arrow, as if they would shoot far away up into the blue sky; they were covered with a perfect shower of bright coral berries, and therein lay the temptation. Great was our grief, and great and numerous were the invectives we poured out on the villanous depredators, but they were miles away by this time, and very likely enjoying the fruits of their ill-gotten prey. How many shrubberies have been damaged and demolished during the past week it would be difficult to reckon; but we feel assured some of our readers could tell of a few, and of many a handsome holly shorn of its beauties. These wanton Vandals do not restrict themselves to cropping and trimming, but in many instances entire trees are borne away. We observed many specimens of handsome well-grown pyramidal trees, from eight to ten feet high, which had been cut off close by the ground, sold for half-a-crown and three shillings, which it must have taken many years to grow. Besides

the Mistletoe and Holly, there was a considerable quantity of Laurustinus, common Laurel, and Yew. Spruce Firs, for German trees, were also in great abundance, and exhibited a perfect forest of little sombre mountaineers.

VEGETABLES.—The supply of vegetables has been unusually great, which is attributable chiefly to the mildness of the weather bringing everything in at once; the consequence is, prices have been rather dull, and sales heavy. SAVOYS were making 1s. per dozen. GREENS, that is Coleworts, which are getting unusually large and coarse from the state of the weather, realised 2s. per dozen bunches, and when a quantity was taken, such as ten or twelve dozen, they were done at 1s. 9d. BROCOLI was very plentiful, more so than it has been for some time. One grower alone had as many as seventy dozen bundles. Now each of these bundles consists of from six to eight heads, according to the size, but taking the average at seven, this would give 5880 heads of Purple Brocoli supplied by one man. These made 6s. per dozen bundles, or 7d. for a single one. CELERY was also very plentiful, and made from 6d. to 9d. per bundle. ONIONS very fine, 3s. per bushel. PARSLEY, 2d. per bunch. POTATOES continue plentiful, and realise from £5 to £7 per ton. There have been a few parcels of SEA-KALE offered during the week, which were sold at from 1s. 6d. to 2s. 6d. per punnet, according to the quality, some of it being very weak and small. We observed also one or two bundles of RHUBARB. These last articles were, of course, both forced, and were of home growth, not imported, as a correspondent says his gardener would have him believe. We thank our correspondent for that communication, which shall form the subject of a few remarks on a future occasion.

FRUIT.—There has been a good supply, but not a very brisk demand for APPLES; that is, not such a demand as the salesmen had made up their minds to expect. Baking sorts made from 4s. to 7s. per bushel; and dessert, from 6s. to 10s. 6d. We observed some fine handsome parcels of the old *Royal Russet*, which realised the latter price. *Blenheims* and *Wellingtons* made 7s. 6d. to 8s., and small *Golden Winter Pearmain*, 3s. There still continues a good supply of *Newtown Pippins* and *Lady Apples*, and there have been several arrivals of the old French dessert apple, *Reinette Gris*. In PEARS, we have only the sorts which have been enumerated in former reports.

PLANTS AND FLOWERS.—There has been a great show in this department. The CUT FLOWERS have been particularly fine and choice. They consist of *Camellias*, *Scarlet Geraniums*, *Epiphyllum truncatum*, *Azalea indica alba*, *Begonia coccinea*, *Chorozemas*, *Cypripedium venustum*, *Roses*, *Christmas Roses*, *Violets*, *Chrysanthemums*, *Euphorbia splendens*, *Chinese Primroses*, *Polyanthus*, *Narcissus*, and *Lily of the Valley*; the two last being forced. FLOWERS IN POTS, were *Erica gracilis*, *Mignonette*, *Chinese Primroses*, *Van Thol Tulips*, and *Cinerarias*.—H.

GOSSIP.

It happens to those of moderate income, almost as frequently as to the wealthy, that they are desirous to *transplant a large tree* to some more desired position. The plan of Brown, and its improvement by Sir Henry Steuart, are well-known, and equally so for the difficulties it involves. A more efficient and easy mode, it is said, has recently been invented by Mr. Stewart Mc Glashen, Sculptor, of Edinburgh; and the following report of its success has been sent to us. The experiment was conducted in the presence of a great number of gentlemen and practical gardeners.

"The tree first experimented upon was a slender sycamore tree, of fifty-three feet in height, and five feet four inches in circumference at the thickest part of the stem. The soil was exceedingly damp, from the heavy rain of the previous night.

"The first process of Mr. Mc Glashen is to lay down a frame of T iron—in this case ten feet square. He then takes cutters made of malleable iron, one foot broad, and three feet deep, or, with the head and neck, four and a-half feet. These cutters are driven, by a wooden mallet, into the soil to the depth of three feet all around, and, being inserted sloping inwards, they give to the enclosed mass the form of a square blunted wedge. A rod of iron is then laid along the top of the four rows of cutters, and extension rods going across the frame force the heads of the cutters apart as far as possible, and, consequently, cause the points to converge at the bottom. A clasp or gland is then put around the trunk of the tree, with a mat under it to preserve the bark. Two parallel beams are then laid across the frame and fastened to it with chains. The above constitutes the frame to be raised. The means of raising the mass is a carriage (which also serves the purpose of transportation) consisting of two strong common carts, one at either end, with bolsters raised above the axletree of both, and on which bolsters rest two massive parallel beams secured to them with strong bolts. The height of the beams from the ground is about six feet. They, of course, enclose the tree. The process of lifting is exceedingly simple—the whole being accomplished by screw power. The screws are four in number, and so arranged as to make the lift equal. They are made fast to the beams of the frame, and are worked by men standing on planks across the beams of the carriage. The frame and enclosed mass are slowly raised, and the tree, with gentle oscillation, moves erectly upwards. The tree may, it is evident, be raised without the use of guy ropes—the solid mass of earth effectually balancing the trunk and branches—but they were used on this occasion as an extra precaution. After about twenty minutes working of the screws, the tree was completely raised from the pit, the operation having been effected in an easy and gradual manner, and amidst tributes of admiration from all around. It was not the intention to remove the tree experimented upon, but the means of removal being exhibited and explained, all seem satisfied with the feasibility of the apparatus for the purpose. A strong case was shown for the enclosure of the ball of earth, when the tree is to be conveyed to any distance. In moving, the tree still maintains its erect position. The propelling power is, when horses cannot be used, by a winch in front of the foremost cart, and block and tackle; but when the way is clear, and the road good, horses will do the work safely and more expeditiously. The tree is lowered into the pit prepared for it on the same principle.

"The cutters, which are driven in around the root, may sometimes sever the more expanding fibres; but this, we understand, will rather insure new ramifications in its adopted soil than at all affect the health of the plant. In fruit-trees, in fact, this is a device resorted to for the extension of the roots, thus giving new vigour to the plant. From the excessive moisture of the soil on Saturday, the ball of earth was not removed in so complete a mass as might otherwise have been expected—the weight of the water dragging the mould not adhering to the root back into the pit, but still there was more than enough of the native soil of

the tree raised with it to insure its preservation; and the circumstances of the experiment were, in this respect, exceptional.

"It is calculated that, in this instance, the weight lifted was thirteen or fourteen tons; but the inventor and patentee confidently states that, by an enlargement of the apparatus on the same principle, he could lift almost any tree. The principal experiment being accomplished, the company were directed to another part of the policies of Cramond House, where a holly-tree, about fifteen feet high, was lifted by four large and broad spades, forming a case to inclose the root. A similar experiment, by smaller implements, was made on a gooseberry bush, while some smaller plants were expertly lifted out by two semi-cylindrical spades. In each case the plant was extracted with its native ball of earth. All this was done, and the party afterwards walked to Cramond House, within the short space of an hour and a quarter."

We think that there is no probability of the price of good *Shanghai fowls* declining. We think so, because such birds combine more good qualities than are possessed by any other variety. At present there is an increased demand for such birds of high quality. At Birmingham, Mr. Punchard sold a cock and hen for £25, and Captain Hornby sold a cockerel and three pullets for £30. The taste for them is not confined to this country; they are most highly prized at Constantinople; and a very few days since, at Southampton, a large pen of about thirty of these birds were shipped for Jersey, and another pen, containing a still larger number, for New York. The taste for Shanghai fowls rests upon a much firmer foundation than some fancied combination of colour, which yet would obtain an enormous price. For instance, it was reported that there would be shown at Birmingham some *White Polands with black crests*, and we know that a gentleman was commissioned to give £100 for the pen if they had been there. No such variety was exhibited; and the last specimens known to have been in existence, we are told, were in the possession of the Duchess of Cleveland.

The following is a list of the *Poultry Shows* of which we are at present aware. We shall be obliged by any of our readers sending us additions to the list, and giving the address of the Secretaries.

CORNWALL (PENZANCE), January 10th, and 11th. (*Secs.* Rev. W. W. Wingfield, Gulval Vicarage, and E. H. Rodd, Esq.)

DONCASTER, January 21st. (*Sec.* H. Moore, Esq.)

GREAT METROPOLITAN, January 1st, 3rd, 4th, and 5th. (*Sec.* W. Houghton.)

HONITON, January 12th. (*Sec.* H. K. Venn.)

TORQUAY, January 14th and 15th. (*Secs.* A. Paul, and J. C. Stack.)

SOME NOTES ON FORCING.

WISHING to make our remarks suitable, as far as possible, to the period at which they first see the light, we will now touch on those things in the order that will best suit the requirements of our readers; and since this popular periodical has enlarged its sphere of utility, there is little doubt of a considerable accession of readers who are in affluent circumstances, and who possess a miniature forcing-garden, wherein they desire to produce those garden delicacies which are every day becoming more accessible to society at large. In assisting this

object, it will be found that THE COTTAGE GARDENER has had no mean share, whether it be as to eatables or decorative matters: it has removed in its day no small amount of ambiguity, and, by tracing matters as far as possible up to first principles, so highly simplified every gardening process, that the owners of gardens may see at a glance whether things are progressing safely or not. It need scarcely be observed, that such adds much to the delights of a garden, and gives a confidence for increased exertions, and the outlay of more capital in garden structures, &c.

KIDNEY BEANS.—Although these may be obtained almost every month in the year, it is not expedient, in ordinary establishments, to attempt to obtain them before February, which may be accomplished by planting immediately. In order to direct the reader's attention to a due economy in the choice of objects for his glass houses, let us consider what conditions are requisite for the forcing and culture of this delicate vegetable. They are as follows:—

1st. All the light it is possible to obtain.

2nd. A temperature of air of 60° for the lowest.

3rd. A liberal amount of atmospheric moisture *ever present*.

4th. A position within a yard or so of the glass.

In addition to these conditions, let us add, that a slight bottom-warmth of 70° to 80° is a very desirable thing if obtainable, although they are very successfully cultivated in pots without it; when they are planted in the soil it becomes highly desirable.

In considering, for a moment, the matter of light, it may be observed, that kidney-beans are very generally placed by gardeners in rows, on the kerb-stones of pits or houses, or on the back shelves of pine stoves or early forcing houses. Where such places are already occupied they may be forced very successfully in frames or pits, especially if fire-heat is applied, and a slight bottom-warmth can be obtained. If fermenting materials alone are used, the forcer must not begin until Christmas has passed, or the probability is his exertions will be rendered futile by excess of damp in the atmosphere. The temperature of air quoted previously must be well secured—Kidney Beans are almost as tender as Cucumbers: they may endure more cold, but under such circumstances they cannot be rendered profitable. And now for culture.

Soil.—They love a soil rich in decayed vegetable matters, but, like a great many other subjects connected with both in-doors culture and the open ground, this is only a part of the question. A steady permanency of moisture at the roots of plants subjected to the capricious fluctuations of forcing houses during dull periods in December and January, is a thing of greater import than even that of manures. However, Kidney Beans *must* have a generous soil; and the stability to which we have adverted must be sustained by some sound loam in the compost. Again, as the season advances, and heat and light increases, so in like manner does an increase in degree of a sound staple become requisite.

For early forcing, then, let there be—a compost of loam, leaf soil, and old manure, equal parts; and, for an advanced period, equal parts loam, and the other two conjointly. Now, this is the gardener's soil generally, but let not our readers be daunted as to soils—almost any generous garden soil will answer very well, especially if somewhat dark in colour. One thing may be observed, and that is—kidney-beans love not raw soils full of fresh organic matter, and this points at once to the eligibility of any sound soils of a generous character, where loamy matters cannot be had.

Pots.—We think it the best plan to use five-inch pots for the first, and when the beans are become sturdy plants to shift them into seven or nine-inch pots; the latter,

although best, require much room, but then the plants are more productive. It is well to put five beans in each pot, and, when they are up, to thin to three; thus, by striking out any two alternate ones, the remainder will be a triangle; and the beans in triangles will—the pots properly placed—serve to economise space. They require but little water until the pots become filled with roots; indeed, they should not receive a drop from the sowing until fairly up, or they may rot; the soil, therefore, at sowing, must be moist, in order to avert the necessity of watering.

In all the stronger kinds the central shoot may be pinched, as in Cucumber plants; this makes them more bushy, and less inclined to ramble; but we doubt the practice with such kinds as the Newington Wonder, and it certainly causes the crop to be a little later. When the plants are in blossom the use of liquid-manure may commence, and, if applied very weak, may be used constantly. We prefer this practice to strong doses, alternating with clear water, which latter plan is fitful in operation, forcing the plant into an expanse of foliage which is an overmatch for the root when the hour of trial arrives. The chief culture henceforth is to see that they receive regular attention as to watering; to suffer them to go long dry is at once to check their bearing, if not to stop it. They must not, however, be kept wet by any means; a medium must be observed.

EARLY CUCUMBERS—THE DUNG BED.—It is now an excellent time for the majority of our readers to commence; by the time this goes to press we shall have reached the shortest day, a subject of rejoicing with most, excepting those who cannot pay their Christmas accounts. It is of no use people commencing the culture of this esteemed vegetable earlier, unless they can see their way as to plenty of warm manure. January, in the main, is a light month; and if the plants can be got above ground by about the second week, capital chances may be secured of cutting by the early part of March, which is pretty fair for ordinary cases. To this end, a body of fresh dung, equal to the bulk of the intended frame, must be immediately thrown together; shaking much of the droppings-out, as they make it too fiery and hasten its decay: the object being to preserve the texture of the bed as long as possible. But here a question arises: Do you make what is termed a seed bed? This is by far the best plan; and a little two-light frame, about forty inches wide, by seven feet long, is a most capital thing for rearing young plants in, both for early Cucumbers and Melons. A frame like this, made up in January, is admirably adapted for sundry propagation or rearing purposes for many weeks afterwards; and it will also serve to rear successive crops of both Melons and Cucumbers. By the use of a "seed bed," the permanent, or ridging-out bed, of course, need not be built so soon by three weeks, and it thus retains its power longer.

And here we may point once more to the necessity of a thorough working of the dung; without this the difficulty of culture will be much increased, as also the uncertainty in the issue. About four turnings must be resorted to, taking care that at each turning plenty of water is used, for this purifies as much as the air. Thus, a heap thrown together to-day, fresh from the stable door, may lie one week at first, then be turned, changing the interior to the exterior, and watering liberally. It may then lie about five days, and receive a similar turning; then another five—at this another copious watering; and again another four or five, and so on; and at the last turning, if tree or shrubby leaves are available, by all means add equal parts with the dung; this makes the best fermenting material imaginable, and it will endure twice as long as the dung alone; besides that, the heat is so much milder, that with ordinary care it can scarcely

burn the roots of plants forced on it. Care must be taken to blend the two materials thoroughly. In building the ridging-out bed, which should be five feet high at back, and four feet at front, we never fill the interior; but merely keep building the out-sides, and what is termed tying-in the corners—that is, adding extra there, in order to bind the whole securely. In doing this, a good deal will of necessity fall into the interior; and by the time the bed is finished, the middle is sometimes more than half-full. Thus there is plenty of room for soil, &c., and it is almost impossible for the plants to burn. We have found it a capital plan, in adding hillocks of soil, thus to proceed:—Place a very large fifteen-inch garden pot, or other vessel, on its bottom, under the centre of each light, the top or rim about fifteen inches from the glass; place it firmly, and fill it with brickbats, and throw a little straw or moss over the surface to keep the drainage secure. On these, and around them, the hillocks are placed, and we have found it impossible to burn the roots; good linings must, however, be sustained for very early forcing. Melons sown about the first week of January will be ripe about the second week in May; and for that purpose either the green-fleshed Egyptian, Beachwood, Bromham Hall, or Snow's, may be chosen. One of the best kinds in the kingdom is a sort grown by our old and esteemed friend, Mr. Collinson, gardener to the Marquis of Westminster, at Exton Hall; he calls it a green-fleshed Egyptian.

We think, for very early forcing, a compost of equal parts turfy loam, leaf soil, and mellow bog soil, excellent; and if the old leaf soil has some little rotten manure in it so much the better, and a little of the charred materials of the rubbish yard may be added. For Melons, it is probable nothing will ever excel a sound loam of a turfy character, and a twelvemonth old at least—that is to say, such as has been more than a year piled in the compost yard. Depth is the great thing with the Melon: the soil should average at least a foot to have them fine; indeed, on this, and on persisting in keeping down all insects by timely perseverance, and by keeping the vine thin from the very first, depends, in the main, successful culture. To say that they delight in a generous heat is a mere truism; but it may be observed, that pains must be taken to sustain a lively bottom-heat to the last, even with summer Melons. Cucumbers may be suffered to part with most of their artificial bottom-warmth in summer, but this scarcely suits the Melon.

Let us advise the early forcer to give his frames a good stoving with sulphur before use, and on the heels of that to apply a clay paint, well charged with fresh lime.

R. ERRINGTON.

BULBS.

(Continued from page 204.)

ANOMATHECA CRUENTA (Blood-coloured).—Of all the small bulbs from the Cape of Good Hope this is the easiest to manage and to increase, and it holds in bloom longer than any other bulb belonging to the Irids with which we are acquainted. From November to March or April, it may be laid by in a drawer in a paper bag, and if it is then potted in peat, or any light sandy soil, it will soon sprout and be ready to turn out into a south border, in patches, or as an edging, in May, where it will soon be in flower; and if the seed pods are destroyed as fast as they are formed, the roots will keep on flowering till the frost puts a stop to them. It seeds as freely as oats or barley. February is the best time to sow them in peat—you may sow them “as thick as hail,” and in May turn out the ball and divide it into four or six pieces, planting each piece separately in the

open border, and by the end of July they are in bloom. I have seen it come up in the borders, from self-sown seeds, as thick as grass. No frost will hurt the seeds, but I am not sure how much frost the bulbs will endure. If there was a good demand for it, there is no reason why it should not be increased so that it could be sold as cheaply as snow drops.

ANOMATHECA JUNCEA (Rush-leaved).—This is not a very desirable species; and I question very much whether it is an *Anomatheca* at all. I have known so many mistakes about bulbs, that I have very little faith in the characters on which they establish genera; yet the genus was founded on this very plant, which is quite a dwarf, with a rather delicate bulb and small lilac-coloured flowers. It must be grown in a pot and in good turfy peat with a sixth part of sand.

BOMAREA.—Beautiful as most of the *Alströmerias* certainly are, we know none of them, either in cultivation, or by dried specimens, that can at all vie in beauty and stateliness with some of the *Bomareas*, of which about fifty species, and many wild varieties, have been figured and described, although we have hardly half-a-dozen of them yet in cultivation, and none of these even second-rate, except *Acutifolia*, from Mexico. About a dozen years back, Mr. Pentland brought over three sorts of them from different situations near Cusco; but that seems to be too far south for much beauty in this genus; the best sorts being in a belt of country in Peru, a few degrees on either side of the line. I never heard the history of the large collection which Hartweg sent to the Horticultural Society, and which were lost at Carthagena; but, from the point where he crossed the Andes, and from the higher sources of the Magdalena, he must have met with some of them. Mr. Veitch has others gathered by Mr. Lobb; but hitherto they have flowered in winter, and not to Mr. Veitch's mind: and no doubt, as his name is up for the best new things, he will not risk the chance of giving disappointment, so he proves his things before he lets them out of his hands. If his *Bomareas* are really winter-flowering plants by nature, they will not do here, as they, all of them, ought to flower in the open air, and in dry weather, else their delicate tints are gone. After describing what few of them we have in cultivation, I shall give the names and localities of some of the best and most desirable to procure, in the hope that some one will lay a train by which to get them down from the mountains to some ports in Peru, and thence home by the Panama route. In Chili they call the whole tribe, *Flos Martini*, “St. Martin's Flower.” Perhaps the same in Peru, and if so, that would be a hint to any of the natives for looking after them.

BOMAREA ACUTIFOLIA.—This is the best of those we have in cultivation. In good, rich soil it twines up ten to twelve or fifteen feet, and flowers in drooping clusters from the ends of the shoots. When the young shoots are about six inches long, in the spring, if the tops are broken off, they will branch better, rise less high, and flower more abundantly. The flowers are nearly scarlet. It ripens seeds freely when trained against a wall, but the plants do not always come true from seeds; all the variations that I have seen are inferior to the species. The simplest way to train all of them is to drive a nail at the bottom of a wall, and to fasten a string or wire to it, fastening it again at the height of eight or ten feet, and if it gets but one turn round the bottom of this it will train itself for the rest of the journey; and if it is a mild season it will keep green to Christmas. It will not cross with any *Alströmeria*.

BOMAREA EDULIS.—The accent is on the u, but half the world put the stress on e. This is a West Indian stove plant, a native of St. Domingo. In the Botanical Magazine, and some other works, it is called *Alströmeria salsilla*, a very different plant from Chili.

The flowers are middle-sized, chiefly red, and the leaves are quite smooth. It is a scarce plant now.

BOMAREA HIRTELLA.—This is the second best species in cultivation, a native of Mexico. The sepals are red, and the petals greenish, dotted all over with red dots; it does not run so much as *Acutifolia*, but it is more hardy, growing up to a stake in the common shrubbery, as I saw it last October, and in flower, near Oxford, in the beautiful garden of the Rev. J. Lys. It seeds against a wall, but will not cross with *Acutifolia*, from the same country. It was first named by Sweet, and figured in his British Flower Garden. After that it was called *Ovata* in the Botanical Magazine; but *Ovata* is a nonentity, and must be expunged from our Dictionary. It goes to rest earlier, and rises later in the spring than *Acutifolia*; these are the two that would twine round for an edging to a bed of *Alströmeria*.

BOMAREA SALSILLA.—This is a Chilean species, and one of the oldest, being the third species which Feuillet brought to France, *Peregrina* and *Ligtu* being the others; but, by a strange oversight in the Botanical Magazine, *Ligtu* and *Salsilla*, out-door plants, were confounded with *Edulis* and *Alströmeria caryophylloides*, which are stove plants, and the error is handed down to this day in some collections. *Salsilla* is a very scarce plant; the flowers are purplish-red, the two back petals having a black spot at the bottom, and the lower petal a light spot. Like *Acutifolia*, it does not always come true from seeds.

BOMAREA SIMPLEX.—There are three varieties of this with reddish-pink flowers. They are Mr. Pentland's plants from Cusco, and they flowered out-of-doors, against a greenhouse, with Dr. Herbert, at Spofforth, in Yorkshire, but what became of them when his collection was dispersed I never ascertained. These are all the Bomareas that I know of in cultivation. Matthews, Tweedie, and Col. Hall, are our chief authorities for the best not yet introduced, of which the following are the chief:—

B. superba. Flowers large, orange and red, twelve in a head, and each flower nearly two inches long. Peru.

B. crinita. Flowers orange and red, on footstalks as long as those of *Cobaea scandens*, setting the flowers widely apart; they are longer and larger than those of *superba*, and ten in a head. It must be a magnificent thing. Peru.

B. crocea. This is figured in the Flora Peruviana, from "Chumpulla in the Peruvian province of Panama." It is saffron-coloured, and grows eighteen feet high.

B. pardina. Twenty large flowers on short stalks, making a superb head of yellow or orange flowers, spotted like a leopard, found by Col. Hall at a place called Patacocha, "on the western declivities of the Andes, at an elevation of 6000 feet." A splendid thing.

B. Patacoccensis. "Another magnificent plant," from the same locality as the last; flowers reddish-yellow, and thirty or more of them in a crowded head.

B. lutea. Flowers bright yellow (Col. Hall), by the road to Mindo, at an elevation of 9000 feet, "on the western declivity."

B. formosissima. Figured in the Flora Peruviana; flowers large, purplish-red and yellow, the petals richly spotted, and as many as eighty flowers have been counted in one head! It grows from ten to twelve feet high, "in woods near Munna."

B. Hookeriana. Petals deep orange; sepals red; one hundred flowers in one head! and leaves six inches long. From the province of Chacapoza, in Peru.

B. densiflora. In habit and colour like *Acutifolia*, and with nearly as many flowers as *Hookeriana*, and from the same locality.

Now, to say nothing of some most beautiful *Alströmerias* and *Collanias* that might be met with, and fifty more plants equally beautiful, that we know of only

from dried specimens, these *Bomareas* themselves would pay a spirited nurseryman to send out a clever man on purpose for them. Every one of them would outlive the winter with slight protection, or, what is just as likely, without any protection whatever. Their very names are circulated to-day for the first time among British, or even European gardeners, and how can we push for things we know nothing about.

BRAVOA GEMINIFLORA (Flowering-at-the-joints). This is a small bulb, and in looks is the nearest to an *Ixia* of all the Amaryllids. The bulb is solid like that of a crocus, and about the same size. From among its *Ixia*-like leaves, it throws up a jointed flower-scape, nine or ten inches long, flowering all the way up, two flowers at every joint, of the same shape and colour as the flower of *Watsonia meriana*, a dull red-tubed flower, but not more than a sixth part of the size. It is a native of Mexico, where it takes a wide range. Galeottu found it growing with *Sprekelia formosissima*. I had it from him, and I flowered and seeded it in an open border. It goes to rest all the winter, and will grow in any light soil. It does not appear to do well in a pot. I never see this plant without its reminding me of an item in the invoice sent with it—£48 for a stupid mule, which made a false step, pulled a huge Cactus out of a gorge, tumbled over a precipice, and broke his neck, yet the brute may be alive to this day for ought that I know. The British Consul in Mexico at the time could tell the tale better than I can.

BRODLEA CALIFORNICA.—This is a true *Lilywort*, and is hexandrous, or six-stamend, notwithstanding the views of Decandolle, which are followed in our Dictionary; the old genus has been split many years, and the species with three barren stamens are now called *Leucocoryne*. The present species is the newest of them. It was sent to the Horticultural Society, in 1848, by Mr. Hartweg, from "the mountains and plains of the Sacramento, where it is scarce." It is a very desirable hardy bulb, with pale-blue flowers, having a dark line up the centre of each petal and sepal. It propagates itself readily by offset bulbs from the old one, and it flowers in any good garden soil from July to October; but the great value of this plant is for improving the other species, on the supposition that it will cross with any of them. The Chilean section, called *Leucocoryne*, are the most difficult to keep, to flower, or to increase, of all the half-hardy bulbs. One of them, which I shall mention in its proper place, is so like this one in flower, and both are so like *grandiflora*, except in the relative size of the parts, that one can hardly believe they would refuse to cross. The constitution of this plant must be very similar to that of the Chilean species, judging from the nature of the two localities.

BRODLEA CONGESTA.—This is a North American species from the southern states, and may require, like *grandiflora*, some protection in hard frost, as does the *Atamasco lily*, from the same parts. This has a light blue flower, but is more dwarfish, and smaller in all its parts than *grandiflora*. The three are not well adapted for pot culture, owing to their way of growth, like the *Ixiolirions* of Syria, and our own *Squills*. These, their allies from America, look better in borders, and are less liable to mishaps there than in pots. For a man to be able to grow a good collection of bulbs in pots, he would require to find out a part of the world where no one could get at him from one year's end to another.

BRODLEA GRANDIFLORA.—Notwithstanding the name, this flower is not quite so large, nor of such strong substance as *B. Californica*. In other respects it is much like it, and it is equally hardy, and flowers in summer. They all rest in the winter, and prefer a light, deep sandy-soil, if it is fresh, and if not, leaf mould is the dressing for them. In very hard weather the border should be covered with saw-dust, tan, or coal ashes, and,

what is of much more consequence, means should be at hand to throw off the wet. Much wet is more injurious to half-hardy bulbs than cold and frost when the soil is dry, and placing clean sand about them is the best preventive.

BRUNSVIGIA.—All the true *Brunsvigias* form a very natural section of *Amaryllis*, with which they are now known to interbreed, establishing identity of kind. They have all very large oval bulbs with a short neck; their leaves are very broad and recumbent, or lying flat. They all flower in the autumn, after resting three or four months, and before the leaves come, and all of them grow with us from October till May. *Amocharis falcata*, the *Brunsvigia falcata* of our Dictionary, and of others, differs essentially from the true *Brunsvigias*—in resting four or five months in winter, and in not flowering until the leaves are full-grown. Our *Brunsvigia cilialis*, *disticha*, and *toxicaria*, belong to a very different section, if not a true genus, called *Buphane*; and *Brunsvigia coronica* of our Dictionary is an *Amocharis*, and cannot be determined from *A. falcata*, unless the two were in flower together. *Coronica* is figured in the Botanical Register, and called an *Amaryllis*, which is very probable; but the fact has not been yet proved; at least not to our satisfaction. *Buphane* can hardly be an *Amaryllis*; yet we have seen so many barriers of generic distinctions broken down in these plants, that the wisest cannot say with certainty which is, and which is not, a proper limit to the genus, in the absence of natural experiments in crossing them. Therefore, in treating on all the species under *Brunsvigia*, as they stand in the Dictionary, I shall notice their sections within brackets, and explain their cultivation separately under each species. D. BEATON.

(To be continued.)

SOFT-WOODED, WINTER-BLOOMING, GREENHOUSE TWINERS.

TROPEOLUM LOBBIANUM.—Most of our readers are well acquainted with the Indian Cress family, from the hardy annuals, commonly, though improperly, named *Nasturtiums*, with their large showy flowers, and large round, pellate leaves; to those more tender, tuberous kinds, such as *tricolorum*, in which the flowers are beautiful and well seen, though small, and more or less hand or finger-like divided. The species I have named above was introduced, some eight years ago, by Mr. Lobb, from Columbia, and may be said to hold a middle place in the group, the plant, when vigorous, having large pellate foliage, and, comparatively speaking, small flowers. What should be aimed at, therefore, is to make its reddish-orange flowers as numerous, and the foliage as small as possible. For real usefulness this plant is second to none of the family, while, if a few simple matters are kept in view, it will stand roughish treatment, and thank you for it too. As an ornament for the greenhouse, in winter, few things will beat it. I was delighted with it several years; and though, like many other good things, it has been set aside for a time, I intend to give it a niche next season. To save annoyance, I may mention, I never could please myself with it, unless for winter and spring blooming, though I have tried it many ways out-of-doors during the summer; planting it out in the open ground, so that it might run up a post, or along a chain; potting it in poor, sandy soil, and even cutting the roots to prevent luxuriance, and cutting off whole masses of the larger foliage; but do what I would, the few flowers that showed themselves, long-stalked as they were, were too much hid by the luxuriant foliage. Under such treatment, however, it showed itself to be a hardy annual, as the seeds that

were self-sown came up as vigorously the following season as the common *Tropæolum major* generally does. I might say, therefore, that the plant is truly valuable only for winter-flowering.

“How must I treat it best for that purpose?”—It is easily propagated. Seeds sown in a slight heat in April or the beginning of May, will vegetate freely. Cuttings taken off about the same period will answer equally well, or rather better; but, however raised, the plants will soon become vigorous enough. If raised from cuttings, place the cuttings in sandy soil, round the sides of the pot; and place it in a shady place, under glass, and in a little extra heat, if previous to June. You may cover with a bell-glass, but take it off partially, or wholly, at night, or the succulent shoots will damp. As soon as rooted and growing, whether plants or cuttings, let them be potted off in four-inch pots, kept close and warm, to encourage growth, and shifted into a size larger pot, as soon as the first is filled with roots, and keep close again, until growth is freely progressing; and then give air, gradually at first, and then freely; until by the beginning of August, at farthest, the plants may stand in the open air, fully exposed to all the sunshine they can get. Previously to that, however, they should have received their last shift. A pot eight inches in diameter will be large enough to fill a globe trellis three feet high and two feet in diameter. To mount a column, and span a wide arch in a conservatory, a pot nearly double the size would be necessary; for intermediate sizes act accordingly. The soil during the whole growing period should be light sandy loam, with a dusting of leaf mould and charcoal. When the luxuriance is gone, and the plant is showing profusion of bloom, manure-waterings, or a good top-dressing of old cow-dung and charcoal will be gratefully received.

Whether grown for an arch or a trellis, one shoot will always be better than many. If for an arch, it should be taken up a stake, and then on a cord fastened to the top of a wall or pole, and then moved and fastened to the arch in September, and the shoot stopped when it has nearly filled the allotted length. Manure-waterings, and removing by degrees the larger leaves, will cause the side-shoots to grow freely; and then these dangling a yard in length, and covered with bloom, the leaves being little larger than a sixpence, few things are more beautiful. One of the finest things I ever saw in this way was produced from the *Maurandya Barclayana*, but then, so grown in a house, its beauty was gone by August, when it, and such other things, might well be succeeded for three or four months by this *Lobbianum*. As a trellis-plant, however, it will be chiefly used. By the time its one shoot has reached two feet in length, begin to train it round, each turn being about six inches from another, having the point of the shoot looking upward to encourage growth. When thus it reaches the top of the trellis, let it be trained a little back again, and then stop it. Ere long, not only from the base, but all over from the axils of the leaves, young shoots will peep; plenty of water must then be given, and full exposure. At short intervals, a number of the larger leaves should be removed. Do not be afraid in the matter, as we are not thinking of getting larger roots, but a profusion of bloom, with smaller foliage, and with proper watering, there is enough of succulence in the stems to prevent all danger if you do not go to great extremes in thinning. The plants should be housed by the end of September. During winter you will see the propriety of removing at the right time the larger leaves, as for several months you will scarcely see a green part, owing to the dense thicket of blooms. The flowers are useful for nosegays, owing to the great length of their flower-stalks. I have deemed it right to chronicle these little matters, as though the plant is of little pecuniary

value, few things will beat it in winter when thus managed.

As I have got upon this genus, I may just allude to two more.

TROPEOLUM PENTAPHYLLUM is one of the hardiest of the tuberous-rooted kinds; a native, I believe, of Monte Video. It blooms freely out-of-doors from June to November. On this, the 20th of December, it is still in fair condition, running along a wire between two posts. Like most of the tuberous kinds, you cannot predicate with certainty on the time of its growth. Instead of starting in spring, you will find that they sometimes begin to shew themselves in July, and later; and by keeping them cool and dry, the period of starting will always be retarded, and in course of time get into a habit. Now, I mention this, because all late-starting bulbs of this species will bloom nicely during the winter, and profusely in early spring, along the rafter of a greenhouse, or round a large trellis, if it has *plenty of light and air*. The soil, however, must be open and rather rich if in a medium-sized pot. I have seen them thus treated keep beautiful for the most part of a twelve month.

TROPEOLUM TUBEROSUM.—A correspondent, lately speaking of the pretty *nice* tubers he had so successfully obtained, but which our English epicures are very careless about, added, that he would like much to know how to bloom it. Now I question if ever it could be made to rival *Lobbianum*; but there is no saying what it might do, if it had house-room, and plenty of it, in *winter*. Even when I have started the tubers early, I never could get the shoots to show bloom until *late* in the autumn. I recollect, that when first introduced, it was mentioned as a plant that grew three feet in height; but three yards, or even three to that would be nearer the mark in our moist autumn climate. I have been rewarded with a fair portion of bloom *twice*, in both cases late in autumn, in such a mild season as this; once, in a greenhouse where there was no heat, and once against a wall. In both cases the blooming was arrested by frost in November. The plant against the wall, as well as that in the glass case, was confined in a pot, and the soil was a little peculiar, nearly one half sandy loam, the rest *roughish gravel*.

MANETTIA BICOLOR.—This, with its red and yellow tubular flowers, is a gem of the first water. It generally blooms from November to April. A warm greenhouse is the place for it in winter, such as will suit progressing Cinerarias and Geraniums. A cool, airy greenhouse, such as would suit Heaths and Azaleas that you did not wish to hurry into bloom, would be too cold for it; a common plant-stove, far too hot. The same remarks apply to most of the family, especially during their blooming periods. This is, therefore, best when trained round a trellis, so as to be moveable; one, two-and-a-half feet in height, will give you means for a nice little plant. It is also one of those things for which a flat trellis, I mean an upright one-sided one, may be tolerated; as the blooms look very nice when thickly studded on such a surface. The *soil* it likes is formed of equal portions of heath mould and loam, both fibry, with sand and charcoal to keep it open. Manure-waterings, if weak, may be given with advantage during the summer, when the plant is making its growth. When standing in the greenhouse in winter, a double pot will be useful, to save the roots from being at any time suddenly chilled. The water used should, for that period, be always warmer than the atmosphere of the house. If there is no other convenience, when the plant has done flowering, it should be pruned considerably, and be kept in the closest and warmest end of the house, until growth is freely progressing, when it must be gradually exposed to full light and air. But, where there are hotbeds, or forcing-houses, the neatest plants for winter use are obtainable from cuttings struck

about March. The following is the routine for such plants. Choose firmish side-shoots, about three inches in length; and, as second best, the points of other shoots that are getting rather firm; insert them in sandy soil, with silver sand on the surface; water, and when the leaves are dry, place a bell-glass over them, and set the pot in a mild hotbed; shade from sun; in a week, plunge the pot, if bottom-heat is not above 75°; ease the bell-glass at night with a pebble, to give a little air, making it close in the morning; pot as soon as they root, and as soon as the small pot is filled, pot again, and keep in the hotbed; top the shoots, that you may multiply them; an eight-inch pot will grow a nice plant; by the middle of June take them to a cold pit, keep them rather closish until August; expose them freely to sun and air in September; give less air towards the middle of October; by the end of the month remove them where they can have a dry heat, or, for want of a better, to the warm end of a greenhouse.

R. FISH.

THE CHRYSANTHEMUM.

(Continued from page 224.)

HAVING given in my last a few hints on cultivating this favourite flower, I now proceed to give a selected list of the best sorts, such as will answer "Cato's" purpose, as well as of any other grower who wishes to make addition to his stock. The list includes good old kinds, as well as more recently raised ones. I went purposely, at the time they were in bloom, to see a large collection, in order to be sure of selecting good varieties.

LARGE-FLOWERED CHRYSANTHEMUMS.

Annie Salter, deep yellow; fine form, very double; the best of all yellows.

Barbette, rosy-pink; neat flower and good form.

Beauty, a lovely blush colour; finest form, large flower; one of the best.

Bixio, violet-carmine; good form, and rich colour.

California, golden-yellow; very fine.

Chancellor, clear sulphur; fine form.

Christine, light rose; very double, fine form; a good show flower.

Clustered yellow, very double; a tasselled flower of a fine colour.

Cloth of Gold, golden-yellow; extra large; a fine show flower.

Comte Rantzan, dark bright crimson; excellent shape; a good show flower.

Cyclops, fawn and buff centre; good.

Defiance, clear white; extra form, large and very double; fine show flower; has probably won more prizes as a white than any other variety.

Dupont de l'Eure, light carmine, shaded with orange. This is a fine variety.

Duke, a pleasing blush colour, and a fine show flower, with good properties.

Etoile de Versailles, blush-white, tubular florets; very double, and one of the latest bloomers.

Formosa, clear white; fine form; a good show flower.

Fleur de Marie, beautiful clear white, anemone-flowered; fine form; one of the very best of its class.

General Rochambeau, light claret; good form.

General Marceau, light blush; a fine show flower.

Gluck, bright golden-yellow, anemone-flowered; very double, large, and a good show flower.

Goliath, a large white flower; well adapted for exhibition.

Hengist, rich dark orange; fine form.

Hecuba, salmon, shaded with orange.

Jenny Lind, pure white, incurved and very double; extra good.

King, light rose; a beautiful colour, very double, and a fine show flower.

Lady Talfourd, pure white; very large.

Lavinia, a large flower, of a rosy-blush colour.

Lucidum, good white, incurved; a fine show flower.

Madame Camarson, red-crimson, tipped with gold; a rich-coloured flower, very double, and first-rate form.

Madame Godereau, light bronze, very double; a fine show flower.

Margaret d'Anjou, dark; a fine show flower; extra.

Miss Kate, a delicate lilac colour; fine form; extra.

Nancy de Sermet, a clear white, very double anemone-flower, rivalling *Fleur de Marie*.

Ne plus Ultra, large flower, of a pleasing lilac-peach colour.

Nonpariel, rosy-lilac; large in size, and excellent in form.

Peruvian, dark golden colour; a fine show flower.

Pilot, large flower, of a beautiful pink colour; a good show flower.

Pio Nona, orange-red, with golden tip; a rich, fine flower.

Polycete, bronze-orange, a large semi-double flower, long petals; fine.

Phidias (New), very distinct, from the old *Phidias*; rose shaded with red; very large.

Queen of England, blush-white; a splendid large show flower.

Queen of Gypsies, deep orange-red; large and fine.

Rabelais, carmine and yellow; extra show flower.

Sydenham, light carmine-red; a good show flower, with excellent properties.

Temple of Solomon, fine yellow; a good show flower.

The Warden, deep orange, with a darker border; a large, incurved, extra show flower.

Vesta, clear white; good form; fine show flower.

Vulcan, fine dark crimson.

Zoe, rosy-blush; very large.

SMALL-FLOWERED, OR POMPON CHRYSANTHEMUMS.

Adela Renard, pale purple; fine form, and very double.

Argentine, silvery-white, very double, free flowerer. In my opinion this is the best of all the Pompones.

Asmodée, bronzy-red; fine form, but rather flat in the face of the flower.

Autumna, bronzy-buff; double and constant; good.

Bouton de Venus, rosy-white; double, and free-bloomer.

Circe, blush-lilac; neat, double, and good form.

Cybele, golden-yellow; fine.

Elize Miellez, deep rose; fine form; very double.

Fenella, bright orange, rather small, but good form.

Fritillon, yellow; good form, medium size; extra.

Harriet le Bois, lilac centre, with purple tops; good.

Jonas, a fine-formed flower, pale lavender.

La Sapajou, orange and red, anemone-flowered, with smooth petals; double, and good form.

Madame de Contade, shaded blush; fine form.

Madame le Comtesse de Vatry, light purple, broad petals; fine form, and very double.

Nonsuch, light yellow, very double; excellent form.

Nini, buff, with white centre; neat, and very double.

Perle de Brezil, white; fine shape, very double.

Pompon d'Or, bright golden-yellow; double, and finely formed.

Renoncule, rosy-carmine; very distinct and fine.

Roi de Liliput, rose, with carmine edge; double, and of an excellent shape.

Sacramento, dark yellow; one of the best.

Stella, deep yellow; free bloomer, very double, much in the form of a Ranunculus.

T. APPLEBY.

CONIFERÆ.

(Continued from page 207.)

LIBROCEDRUS.—A genus established by the late Professor Endlicher out of the Arbor Vitæ (*Thuja*). Dr. Lindley tells us, in the Horticultural Society's Journal, that the Professor's reasons for so doing are "mainly on account of the scales of the cones being pressed face to face, instead of overlapping at the edges; he also relied upon some difference in the seeds, which appears to be of less importance, and which are not exactly as that lamented botanist supposed them." As this botanical distinction in the genus appears to be sufficient to the acumen of the learned doctor, I have adopted it in this list of Coniferæ, though no common observer could, by its habit alone, see a sufficient difference to separate it from *Thuja*. The name, too, is used in the gardens at Kew, and in all the nurseries round London, and at Bagshot; so that we may consider it fairly established.

LIBROCEDRUS CHILENSIS (Chilian L.)—A beautiful tree, attaining, in its native habitats, the height of forty feet. It is found in valleys amongst the mountains of Chili. It has a considerable resemblance to the common American Arbor Vitæ, yet is easily distinguished from it by its more silvery green, by branching more from the base, and often forming a more conical head. Seeds have been imported largely, and, consequently, plants are plentiful in the nurseries, especially in that of Messrs. Low and Co., at Clapton, and at Mr. Hosea Waterer's, at Knap Hill, near Bagshot. It is perfectly hardy in the south of Britain, and probably will be in the north also, if planted in a sheltered situation. As it is a most beautiful tree, it ought to be in every collection.

L. DONIANA (Mr. Don's L.)—This species is a native of New Zealand, and therefore requires the protection of the conservatory. In its young state it might be easily taken for a dense tree Lycopod. There are some fine specimens, four to five feet high, in the greenhouse at Kew. Here they are strikingly beautiful, from their bright, lively, green foliage and singular habit of growth. As an ornament to the conservatory there are few Coniferæ that surpass it in beauty. In its native woods it attains the magnificent height of seventy feet, and is useful as a timber tree, the wood being beautifully grained, close, and heavy.

L. TETRAGONA (Four-sided L.)—From South America. Dr. Lindley observes, that "this species bids fair to be a rival to *Araucaria imbricata*, and to be as hardy, for it comes from just below the snow line of the Andes of Patagonia, where Mr. Lobb found it in the state of a tree from fifty to eighty feet high." It is a magnificent evergreen tree, and, being likely to be hardy, will, when it becomes more common, be planted as largely as its rival the *Araucaria*.

PHYLLOCLADUS, a name derived from *phyllon*, a leaf, and *klados*, a branch. This is a small genus of singular trees, scarcely hardy enough to bear the severity of our winters; but they should have a trial in such counties as Devon and Cornwall, or perhaps against a conservative wall for a few years, till they become woody, and inured partially, and afterwards planted out in a sheltered situation, they might become more able to resist the cold. I have seen one species, the *P. rhomboidalis*, growing in the open air in the Botanic Garden, at Belfast, and was informed it had stood the winter there with scarcely any protection; but then the climate of Ireland is much milder, especially near the sea, than most parts of England. In that locality (Belfast) I saw Fuchsias twelve and fourteen feet high, with stems as thick as my leg, and apparently ten or twelve years old, quite bushy trees. Well may such trees as *Phyllocladus* live through the winter in such a climate. It is true the Fuchsia is hardy here also, but it only exists as

a kind of herbaceous perennial, dying down to the soil edge every ordinary winter.

PHYLLOCLADUS TRICHOMANOIDES (Maiden-hair-like P.).—This is another remarkable New Zealand tree, bearing some resemblance to the curious-leaved *Salisburia adiantifolia*, only the leaves are more divided at the margin. When young, the foliage is a blue-green; but as the leaves become old they become of a dark brownish-purple, giving the tree a most singular outlandish appearance. As a contrast in colour, as well as a great curiosity, the plant is worthy of a place in a large conservatory. Like most of the New Zealand trees, its hardihood, except in highly-favoured situations, is more than doubtful, and it is, therefore, safer to give it a gentle protection. A very interesting collection might be formed of trees and shrubs like this that would live in a glass-house without heat, but are not hardy enough to be entirely exposed. The only expense would be the cost of the building at first, the keeping them clear of weeds and insects, and a little attention to pruning, and thereby keeping them in form. Some day or another I will draw up a list of plants suitable for such a cold habitation. I am quite sure such a building would be useful, for more plants are spoiled by too much heat than many persons are aware of.

P. RHOMBOIDALIS (Rhomboid or Celery-topped P.).—This is the *P. asplenifolia* of Dr. Hooker the younger. It is a native of Van Diemen's Land. Like its co-species, it has a most singular appearance, and is a beautiful branching tree, found growing close to the sea-shore. It can only be called a half-hardy tree, requiring the protection of a conservatory, or a glass-house without artificial heat.

T. APPLEBY.

(To be continued.)

HOT-WATER versus POLMAISE.

SOME years ago, a warm controversy was carried on in our then existing gardening periodicals of the relative merits of the two modes of heating noted above. The advocates of the newly-invented system of heating by propelling currents of warmed air to circulate through the interior of the building, insisted that the sluggish warmth imparted by hot-water-pipes or tanks, tainted, rather than improved, the condition of the atmospheric air it acted upon; and though it supplied the necessary amount of heat, it was said to be more of a mechanical than of a natural kind. Against this imputation, the friends of iron and water pointed to the many instances in which the atmosphere of structures intended to be Polmaise was little more than a compound of smoke and steam, supplied separately or together, as the case might be; while, in some other cases, where these agents were kept under proper control, the heat supplied was, by certain wayward propensities of its own, all confined to one end, or other place of entrance; coupled with these evils was the extravagant use of fuel required to furnish heat from so limited a space as that from which it was, in the true Polmaise system, confined; this latter evil led to the apparatus taking the character of a "flue" (either long or short) entering or traversing the house; where such was done, the Polmaise resolved itself into nothing more than the old-fashioned "smoke-flue," about whose action our grandfathers knew about as much as we do. Various improvements, in the way of amalgamating the flue and Polmaise together, were tried with more or less success, and the latter plan itself became so altered in character, that its original inventor can hardly recognise it now as having any analogy with the "hole-in-the-wall," and "wet-blanket" mode by which he first introduced it. However, it must be admitted, that some of those hybrid contrivances, whereby the merits of the Polmaise and the smoke-

flue become united, act tolerably well; and, in some few instances, where good gardening skill is brought to bear in the matter, the production of such Polmaise-heated structures cannot be excelled by that of any other contrivance whatever; it is, therefore, only just to infer from such results, that the principle is a good one, but the practical details of working it out rather difficult. This, I believe, its most sanguine friends admit; since none, that I am aware of, have continued long in working order without something going wrong, or, it might be, an improvement appear feasible.

I believe the most successful cases of Polmaise-heating are to be found amongst the class called amateurs; nurserymen, and others in trade, having less interest in novelty than proved utility; while a gentleman's gardener, recommending the construction of anything differing much from what preceded it, is supposed to place himself in the position of warranting its utility, and naturally enough strives to make it fulfil its intended purposes. So that, in cases where the adoption was at his request, I believe the plan had as fair a trial as could be given to anything where the reputation of the adviser was at stake; still, there were many cases where it was abandoned, and hot-water, or something else substituted, and this at a time when gardening periodicals were pourtraying its merits, or decrying its inutility; in fact, the time chosen was one in which it might be fully said to have every advantage of a fair trial, its advocates and accusers being both men of experience, and well qualified, by long practice, to judge of the merits of anything likely to be of advantage to the horticultural world; but the test still lay with that mighty dispenser of justice, "the British public," who, however prone to run away after every novel piece of quackery, be that a railway or a universal medicine, is, nevertheless, sooner or later brought to exercise a sound judgment on each individual case; and in the one regarding Polmaise, it can hardly be questioned by its best friends, but that the public verdict has been an adverse one; there may be those who doubt the justice of that verdict, the same as others may differ from that of the Lord Chancellor in other matters, but that does not much affect the case; for until some strenuous friend of Polmaise show "just cause why its merits have been undervalued, and its defects overstrained, or rather, until he be able to improve the one, and diminish the other, Polmaise must certainly stand second to hot-water as a heating medium." In this view, I believe, I am sustained by the great body of the horticultural world, and certainly by none more so than those who, having given it a fair trial, have abandoned it as defective. Still, it must be admitted, that there are some instances where it has been found to answer, and admirably to; and where it does act well, the condition of the products inside tell, in unmistakeable language, how well the plan suits them.

The advantages of a circulation of air, which it is said the Polmaise has over that of other plans, is certainly an important adjunct to the well-being of either the animal or vegetable world; but we may yet live to see a greater circulation of air in hot-water-heated structures than has yet been done by a more liberal influx and efflux from and to the open air. It may be true, that some expense will attend heating a certain quantity of air allowed to escape, but if it be attended with increased luxuriance to the plants grown there, the matter becomes one deserving attention; but this is foreign to the subject of weighing the merits of the two systems as they now stand, so that we must look to the results accomplished in each case; and, giving due attention to the trouble and expense in each instance, we are certainly led to believe that hot-water is, in nine cases out of ten, preferable to Polmaise, as, even with those who have managed the latter in the best manner, the

consumption of fuel is much greater than in hot-water-heated structures. This is certainly an object of consequence where firing is dear, added to which, is the difficulty of contriving to have the fire to act on a substance that will admit the greatest possible amount of heat through without giving way in any manner. Cast-iron plates have been tried, but the action of the fire on the one side expanding that side soon deranges it; and, the edges curling up or down, the smoke escapes into the house as well as the heated air. The best apparatus for heating in that way was by using what hop-driers call a "cockle," which is a square cast-iron box, of something like five or six cubic feet interior dimensions. This box, being cast whole, is without a lid, and an opening (not very large) is made on one side, to which a piece of pipe is attached, conveying the smoke to the chimney. This box, being turned bottom upwards over the fire-place, is thus secured; but the air to be heated has access to it on the top and all sides as well as the one from which the smoke-flue proceeds. This is usually built against the wall, and not unfrequently the front wall, because it enables all the other sides to act on the hot-air chamber. The admission of cold air to this chamber, and the outlet for the warmer portion, by passing over a vessel of water, &c., are the matters in detail which have long been subjects of controversy. Suffice it to say, that in the few instances where it has proved successful, it has been eminently so; while the many cases on record where it has failed, present a sad tale of the damage done by smoke, steam, want of heat, and many other evils. These disasters, repeated so often, imply either a defect in the construction, or that the plan must be a hazardous one. Taking the latter for our guide, we would at once advise the amateur, who is about building or heating a pit or house, to make himself well acquainted with Polmaise before he ventures to adopt it; and, in the absence of the most perfect confidence of his experience that way, we advise him to try hot-water in some of the many shapes it is now presented to our use, which, though none of them be so perfect as they may become, are certainly more likely to give satisfaction than the hazardous plan of Polmaise; but more of this anon.

J. ROBSON.

THE POOR TAILOR.

By the Authoress of "My Flowers," &c.

I AM going to introduce my readers to a scene of quiet, unobtrusive want and distress, which very few know anything about, and which it would be very wholesome to many of us to see and understand. Poverty is sometimes clamorous, and most frequently easy to be perceived. We look for it among the humblest classes, and for them, what can be done is always set apart; but there is a class of sufferers which do not come within the limits of what is called charity—they are too respectable, too delicate to beg, and too superior in their little station to be supposed to be in want; so that kind hearts pass them by, and never hear the sigh of the sorrowful through the closed door.

William Jenkins is a tall, thin, pale, quiet village tailor. His wife is as tall, and pale, and thin as himself; and they inhabit so small a cottage, that one expects to see their heads protruding from the roof. Until last summer they possessed three pale, sickly little children, whose voices were never heard, and whose figures were never seen, unless the door was opened, when Jenkins and his board seemed to take up full half of the little kitchen, leaving just room enough for the wife and children to stand or sit still in the darkness and closeness behind his seat. They are such remarkably quiet keepers at home, that no one seems to know anything of them. Jenkins has a bit of allotment ground, which he manages tolerably well, and to go down with their father sometimes to this garden has been the only air and exercise the poor little children enjoy; and their large melancholy eyes, and solemn faces, speak volumes

about the want of childish play which other children have, but which they cannot get at; having no space behind the house, and being strictly kept from running into evil in the street.

Jenkins used always to have plenty of work. Early and late he was sitting before his window, with work piled about him; and then he made nothing of "stepping" over to the nearest town, about seven miles from the village, besides going about for orders, and looking after his garden-ground too. He is a man who knows "the Truth," and can speak well about it—his habits are very sober, peaceable, and unoffending, and as a tailor he was rather an eminent character. He was always obliging, punctual, and fair in his charges—made capital shooting-coats, and rough country clothes, and things seemed to promise well for him and his pale family.

Alas! times are changed with poor Jenkins. *My* views of political affairs are, of course, of none account; as a lady, I am supposed to know and understand nothing; but times are, nevertheless, changed, and Jenkins knows it well. There is no work for petty tailors, shoemakers, and artists of that calibre. People have no money, and their wants are narrowing into as small a compass as possible. More than one of the little tradesmen in the village are almost in a starving state; and they look with trembling upon that which is coming upon them.

Last summer Mrs. Jenkins became the mother of twins. It seemed a severe calamity; for her weakness was great, their privations extreme, and the addition of two babies to their other difficulties was almost overwhelming. One of the elder girls had always been afflicted in health; it was a pining, whining little creature, and its poor mother's nights had always been disturbed and broken with its cries and fretting. Two babies, in addition to other drawbacks, was almost beyond the strength and spirits of the poor mother, and her recovery was long and tedious. Fatigue, broken rest, no nourishment, and five children! Oh, little think the rich what sufferings are endured within the cottages that stand thickly dotted around them. Oh! if they would but search and look, and give with their *own* hand, how much misery would be removed, how much sorrow, and sighing, and sadness, would be done away, even here, now, amid this world of tears and trouble.

One of their neighbours, a kind-hearted, pitying widow, told the tale of poor Jenkins' distresses. She said she knew they were literally in want of food, and that among themselves their poor neighbours had collected a few halfpence to relieve them. Inquiry was instantly made, and it was found quite true. Jenkins was himself unwell, his wife almost exhausted, and one of the twins had never ceased pining and fretting since its birth; so that by night and by day it was a burden to them. Some trifling assistance was at once given; and a kind-hearted farmer did the best thing of all, for he sent them a large can of milk every morning, which nourished parents and children; but it was not possible to do all that was wanted, for they had scarcely anything of their own. Now and then Jenkins earned a shilling, but they could not bear to be in debt, and would rather go without food than take out goods they knew not how to pay for.

Mrs. Jenkins at last recovered from her long illness, and got about again; but the door is always closed, the family are always shut quietly in, and no one sees or hears them.

One day, a lady was passing through a narrow passage that leads by Jenkins' back door to that of another cottage, and stopped to speak to his wife, who was washing in the small space that they called their pantry. Her eyes were bright, but she was thinner and paler than ever, and a child or two were standing quietly by her side, in the midst of the steam and wet linen. In a calm, low voice, Mrs. Jenkins spoke a few words that led to further inquiries, and revealed the extremity of her weakness and distress. She said she has many blessings: her husband never goes into a beer-house, or spends one half-penny from his wife and children—he is kind and thoughtful. Her nights are such with her two babies, that when morning comes she has no strength or spirits. "I seem, ma'am, to be unable to get up—it seems too mighty for me; but then I think to myself, this won't do, I must get on somehow, and I do get dressed at last. My husband lights the fire, and puts

the kettle on, and does what he can, but sometimes I feel as if I could not live through it." There was a vein of religious trust and faith in this poor sufferer's mind. She knew and spoke of God's promises, and she said they upheld her; but for them she should be utterly cast down; and she said she knew that nothing could overwhelm one who acted fully on them. She leaned against the wall, weeping, as she spoke, and said it did her good, and seemed to relieve her, when she could open her heart to one who felt for her; she thought much of her depression arose from weakness of body, for her heart seemed strong, though her limbs trembled, and tears flowed from her eyes.

Poverty like this, perhaps not so meekly borne, but poverty like this meets us at every turn. Where the purse is full, there is plenty for the hand to do; even a word of sympathy and consolation is as balm to the bruised reed, and that can always be given. Where there is only moderate means, much *might* be spared, cut down, or made the most of, to help the suffering, if they were only sought out and cared for. A Christmas, a New Year's dinner, would not do us the less good if it was shared and doled out to the poor, instead of being spread for the affluent. "They cannot recompense thee," saith our Lord, "for thou shalt be recompensed at the resurrection of the just;" will not *this* satisfy us; can we not "call the poor, the lame, the maimed, the blind," for *Jesus Christ's sake*?

The old year is ready to depart, and I would say one word to my readers, for it is a "time to speak." Are we all "considering our latter end?" "An end," "the end" is coming upon us all. Who can say he will live to see the close of another year? Are we *watching*? for "the Lord is at hand." Let us keep a solemn fast; not "to bow down the head as a bulrush, and to spread sackcloth and ashes under" us; "wilt thou call this a fast and an acceptable day to the Lord?" No. Let us listen to God's directions how we shall humble ourselves before Him. "Is not this the fast that I have chosen? to loose the bands of wickedness, to undo the heavy burdens, and to let the oppressed go free, and that ye break every yoke? Is it not to deal thy bread to the hungry, and that thou bring the poor that are cast out to thy house? when thou seest the naked, that thou cover him; and that thou hide not thyself from thine own flesh?" "Then shalt thou call, and the Lord shall answer; thou shalt cry, and He shall say, here I am." My dear cottage readers, and *all* my readers, my pen will never stop if I transcribe these blessings. Let me refer you to the "table of stone," written with the finger of God. Turn, amidst your worldly hurry, to the 50th chapter of Isaiah, read it, *study it well*. Let it be your old year's chapter and your new year's chapter. You are all gardeners; be yourselves "watered gardens;" "draw out thy soul to the hungry, and satisfy the afflicted soul;" be ye followers of Christ, "the Lord is at hand." Every one of us has, I will engage to say, a "poor brother," a needy, or a suffering neighbour; however small our means may be, we may put a "cup of cold water" to the lips of one poorer and sicker still. Let us remember the poor tailor, his weakly wife, and the cradle with a little head lying at each end. This will quicken our search after other objects of quiet, patient suffering; and we shall relish our own loaf a hundred times more, when we have popped one in at a poor man's door. "Then shalt thou call and the Lord shall answer; thou shalt cry, and he shall say, here I am." Can we wish each other a richer heritage for the coming year?

ALLOTMENT FARMING.—JANUARY.

A HAPPY new year to our allotment friends, and our small farmers and cottage gardeners, and let us hope it will be a prosperous one to its very close; that it may prove so, let them enter the field determined to conquer, for there is a bravery in industry, although not precisely that of the battle-field.

Our industrious readers, those who were quite in earnest through the past year in matters of high culture, will now be enjoying their stores, and will occasionally find such things as carrots, parsnips, Jerusalem artichokes, savoys, &c., excellent companions to a lump of boiled bacon; boiled, of course, in the same pot. And here we

stop, to recommend every poor man who possesses a family of children to purchase a bushel of whole boiling peas every November, and to make a point of using them twice-a-week. Nothing is more economical in a house, nothing more nutritious. We have reared a family of eleven children, a particularly healthy family, thanks to Almighty God, and they have been thus dieted during the last twenty-four years, so that we at least claim some experience in the use of peas. We generally boil them in a bag, in the same kettle where reposes a lump of fat bacon, or sometimes a piece of the "bed" of beef, and in the same kettle may be found parsnips, carrots, artichokes, turnips, &c. A bushel of good boilers costs about 5s. or 6s., but they must be good; as for split peas, we never think of them. Children, in general, are excessively fond of peas, we have seldom known them refused. And then the liquor; we always keep a bunch of mint in the kitchen, and this being powdered liberally into the pot-liquor makes capital pea-soup. Whilst on this part of our subject, let us point to boiled leeks as another nice necessary to the poor man's table. Now the leeks must be good, grown specially; our's are as thick as a rolling-pin, and perfectly white; in length from about eight to ten inches, that is to say, the blanched part; these, well boiled, require a little butter and plenty of salt, and then greatly resemble first-rate sea-kale, the blanching process reducing all rankness of flavour.

And, now, let us reflect for a moment on the late extraordinary weather, and the probable consequences. Rain! Rain! and an unusually high temperature ever since the early part of November, and that, too, nearly all over our island. It would scarcely be too bold to challenge a well-bleached old gentleman of some four-score years to produce its equal. It is not a matter of wet alone, but of warmth, or, if you will, mildness combined, that gives a special character to the period we have just passed. And now it is that those who possibly may have thought the advice about thorough drainage, &c., in our autumn allotment papers, too particular, will be convinced that England has not yet half done its duty in this respect. It is of no use looking cross at such pressing advices; the truth ought to be told, and will be told, and the pressure of the times we live in will shortly enforce it.

Some other consequences may be expected to follow also; vegetables, of whatever kind, will be so tender as to become a mass of putrefaction on the frosty trial which may await them; and store-roots, too; we fear the unusual temperature may have the effect of causing much sprouting, and sprouting is a wasting of the stored up virtues of the roots. To be sure, they may increase in size after cutting their heads off, at least so they say now-a-days; but really, this looks too specious to be sound.

Let, therefore, a jealous eye be kept on the roots in store; let them be examined at times in order to be sure that "all's well." These things set in order, the state of the soil should be well looked to as preparatory to the cropping of the next year. Doubtless, portions will have become stagnant through continued wet weather, and means should be taken to enable the waters to pass and the frost to enter. Now, we by no means advise the working of the soil by digging or trenching in a wet state, but lodgments of water may be got away by heaving up stagnant soils here and there, and this we have accomplished lately by using an iron crow-bar, "prising" up the soil, and sometimes by the potato fork. Through the extraordinary wet weather, and the comparative absence of frosts, both farmers and gardeners will be in arrears as to carting and wheeling out manures, and what is worse, many thousands of pounds worth of property in the liquid state will have passed down ditches. These extreme cases will tend to teach people a better economy in manure heaps than to suffer them to lay abroad with large surfaces exposed to drenching rains.

WALKS, BOUNDARIES, &c.—The allotment cultivator requires but few walks, but what he has should be kept in sound repair. It is annoying to think how much time is lost by rotten walks and alleys; they are, in fact, a hindrance to business at all times and in every sense. We find nothing equal to coal-ashes for the purpose, and have made some of the best walks imaginable by applying the quantity intended for a given time, in two coats, one-half laid on and dug in, and the other added without digging, as a casing at

last, taking care to keep the walks full in the middle. This is business which may be at once proceeded with, and any boundary fences or divisions of any kind, which require repairing, let it be done as soon as possible; let not anything of the kind, by any means, or under any pretence, stand over and interfere with spring or summer culture.

MANURES.—Let those plots which require manuring for cropping in February or March be manured as soon as weather permits; it may be spread at once at this period, as little loss by evaporation can take place at this season; but by all means let the ground be dug before a "March dust" prevails. Any manure remaining should be dressed carefully up in a conical heap, patting the outside smooth, or casing it over with soil. We beg again to recommend the preservation of all soot, and if you can beg your neighbours sweepings, so much the better; add them to your manure-heap, only reserving enough in the dry for drill-cropping, or what we term practically "priming." As before observed, get some guano, the real Peruvian, and mix three-parts soot to one-part guano; let these be thoroughly mixed, and to facilitate their mixing, let plenty of really dry dust of any kind be added—we have added wood-ashes. This, when well blended, may receive an addition of ordinary soil to increase its bulk three times, if old leaf soil or very old manure, all the better. Such will be found a capital fertiliser, sown in the drills with the seed of such things as mangold, swedes, carrots, parsnips, &c., and will soon speed the young plant out of the way of mischief.

POTATOES.—As the season has been so mild, folks may expect to have long sprouts on their potatoes at planting-time, unless they have them examined and turned over immediately. If they are advancing too fast, let them be placed thinner; and, if in pits for seed, by all means let them be taken out before the end of the month, and spread on some floor.

PARSNIPS may be taken entirely up at the end of the month, or they will soon sprout, and lose quality. The ground, too, will be placed at the service of the succeeding crops.

CABBAGES.—We advise those who have young plants for spring-planting to protect them slightly if severe frost occurs. Vegetables are so very succulent, that we are perfectly justified in anticipating much destruction in this way, in consequence of their tissue being distended in an unusual way. A large bundle of new straw, or a little fern, strewed over the seed-bed, or those pricked out, will, perhaps, ensure the cultivator a crop. The very best plan is to let them become frozen, about an inch deep, on to the soil, and then to cover in order to prevent them thawing; and by no means dream of uncovering to admit sunshine: keep them asleep if you can until the end of the frost. Those cabbage plants planted in autumn for early work may have a little soil drawn to their stems when tolerably dry, in order to keep their shallow fibres from severe changes.

LETTUCES.—Protect precisely on the same principle as the cabbages, only do not let them endure quite so much frost as the cabbage.

RHUBARB.—Those who have a reason for obtaining this early should throw a covering of the strawy portion of the manure over it when in a perfectly thawed state. This, indeed, should have been done in the beginning of November: but better late than never. There are those amongst cottagers who, keeping a cow and a pig or two, have a little reeking manure; and such we have known to produce Rhubarb of a somewhat profitable character in the market at the end of January. All they want is powerful crowns cultivated specially in a nook sheltered from the winds, and a few old tall chimney-pots, a yard in height. These, the crown having been protected in the aforesaid manner to keep frost out in November, should have their chimney-pots on as soon as Old Christmas has turned his back; and, of course, the warm manure piled around; a whisp of litter tightly crammed in serving for a cover. Of course, sea-kale may be served the same; but we do not advise any but shrewd men of this class to attempt it.

SHANKING.—Most of our readers know that cabbage-plants, lettuces, &c., are liable to wither up in the stem during the winter months: this may arise from various causes. Every one interested in good culture should always keep some really dry dust by him: this furnishes the bulk

of a useful compost. Let him add to a gallon of this dust a half-gallon of quick lime, and as much charcoal dust, and stir them well: this will be found a mixture at once arresting canker processes, and an enemy of slugs, snails, &c.

R. ERRINGTON.

THE APIARIAN'S CALENDAR.—JANUARY.

By J. H. Payne, Esq., Author of "The Bee-Keeper's Guide," &c.

THE sun has again entered his upward course in the ecliptic, and our little pets will be amongst the first to be affected by his influence, therefore it behoves their owners to look well to their store of food, now that they will be arousing themselves to life and activity.

FEEDING.—It will be well, on the first mild and dry day, to have a thorough examination of all the stocks, and to clean the floor-boards. Where it can be ascertained that the stock has eight or ten pounds of honey in store, feeding had better be put off till next month; but where only four or five pounds, it will be safe to commence at once. If honey or syrup is used, choose a mild, dry evening for supplying it; but if barley-sugar, it matters not so much when it is given.

HIVES.—It will now shortly be time to look over the stock of hives and boxes for the forthcoming season, and I would take this opportunity of saying to the readers of THE COTTAGE GARDENER, who may wish to be supplied through me, that if they will make their applications early, it will save much delay and inconvenience; for the poor man who makes them suffers under a painful infirmity, which incapacitates him for any other work, and hurry, even in this, distresses him much.*

SNOW.—Be careful to close the entrance of every hive whilst snow lies upon the ground; for when the sun shines upon it the bees are induced to come out, and scarcely one in a dozen that alights upon it ever rises again.

ENEMIES.—The chief, and, indeed, the only enemies at this season, are birds and mice, both of which should be carefully guarded against.

MOORS.—The reports generally of bees sent to the moors this year are very good, some having obtained a prodigious quantity of honey, in an unusually short time, and of first-rate quality. To this I can bear testimony; for through the kindness of a friend I have been indulged with a bountiful supply of it.

VISITS TO SOME OF THE CHIEF POULTRY YARDS OF ENGLAND.—No. 4.

(PENZANCE.)

(Continued from page 211.)

Mr. Fox, the owner of the nursery grounds, is himself both a fowl and a pigeon fancier. Of the former he possesses several varieties, but they are mostly young birds, and have not attained the size and beauty which they will doubtless exhibit when the time comes for their appearance in the show-pen. These remarks apply especially to some Spanish fowls, as also to a very promising lot of white-crested black Polands—recent importations from celebrated breeders. The colour of its plumage is a great recommendation to the Spanish fowl, when kept in close confinement in a yard of limited space, but at the same time no bird does greater credit to the owner who indulges it with a good run, free from the smoke of towns. The brilliant metallic lustre which is lavished on well-bred specimens—the coral comb, and white ear-lobe extending over the whole cheek, have deservedly rendered it a favourite with many. In former days Mr. Fox, whom we long remember as a poultry-keeper, possessed what were then reckoned first-class birds—*Minorcas*, or, as they were sometimes called, *Ancones*—fowls somewhat more bulky, but destitute of the elegance of the pure-bred Spanish, although attaining great size, and being capital layers. The various appellations assigned to them are geographically correct, for throughout the whole extent of the Mediterranean coasts a race of fowls are found allied to the Spanish, though sadly degenerated when compared to the first class birds of the present day.

* Mr. Payne's direction is "J. H. Payne, Esq., Bury St. Edmunds."

The black Polands belonging to Mr. Fox are still very juvenile, but already display undeniable evidence of a pure origin. The white crest, slightly stained with a few black feathers in front; the wing and tail of the cockerel tinged with white; the comb small and spiked, are the principal marks according to which excellence is now awarded; but in every colour of this race one thing is essential, a full, compact, globular tuft in the hens, while in the male birds it must fall backwards on the neck; for any irregularity in the crest is fatal to the pretensions of either sex.

A black Polish chicken, when first hatched, would invoke the sympathy of the most inveterate antagonist of poultry. Glossy black, with a full development of tuft—they seem to anticipate, in their earliest movements, the ever restless activity that distinguishes their subsequent career.

Mr. Fox has long kept a good strain of both gold and silver laced bantams, whose merits he has been careful to maintain by frequent selection from other fanciers. The present season appears to have given him an undue proportion of cockerels to pullets, so far as the silver laced are concerned. The clear ground colour pencilled with black at the extremity of the feathers—the tail and flight feathers tipped with a dark line of the same—short clean legs of purplish-grey—a comb “rose” in colour as in form, afford us all the points we wish in this Lilliputian family. The gold and silver differ only in the ground colour, the markings of good birds being exactly alike. Many persons imagine that no gallinaceous bird of any kind is safely to be admitted within the precincts of the garden, but Mr. Cuthill, the great market gardener at Camberwell, confirms the advantage of the practice that Mr. Fox has long been accustomed to, in giving Bantams the run of his garden—the number of insects, of the most destructive kinds, that they devour, more than compensates any occasional disturbance of the newly raked border.

Mr. Fox's dove-cote is at some little distance from his poultry houses, which adjoin those of Mr. Bowman, and were built on the same plan. It occupies an admirable position for such a purpose, being sheltered from our prevailing north-westerly winds, and having a clear running stream for the bathings that pigeons so freely indulge in. We have carriers here, both pied and black; the fleshy excrescence around the eye, and extending to the bill, whose length, with the fine head and powerful wing, with its enduring powers of flight, will commend them to admirers of the species. Each quarter of the world numbers among its inhabitants many by whom the peculiar characteristics of the carrier-pigeon have been trained to excellence, and made available for the manifold purposes of stratagem, intrigue, or commerce. From the shores of the Nile to the Ganges was the carrier in active operation, long before his services were employed in European countries. But now his “occupation's gone,” and wherever “immediate” is inscribed, we should now as soon have recourse to the lumbering and slumbering stage-waggon of former days, as desert the railway and electric telegraph for this or any other aerial messenger. The amusing author of the *Dove-cote and Aviary* tells us, in a letter from Mr. J. Galloway to the *Manchester Guardian*, “that the merchants and manufacturers of Belgium have done more to test the capabilities of pigeons than any other people. Their annual pigeon matches produce an excitement almost equal to our horse-races. In 1844 one of the greatest races took place, from San Sebastian, in Spain, to Vervier. The distance would be about 600 miles. 200 trained pigeons of the best breed in the world were sent to San Sebastian, and only 70 returned.” The same authority assures us, that “Carrier pigeons do not fly at night, they settle down if they cannot reach their home by the dusk of evening, and renew their flight at daylight the next morning; the velocity of a pigeon's flight seems to be greatly overrated, and no doubt your readers will be surprised to learn that a locomotive railway engine can beat a carrier pigeon in a distance of 200 miles.”

But we must now pass on; a very beautiful pair of fawn-coloured *Jacobins* (first prize at the Penzance Show) are side by side with a Nun. The Capuchins, by which name the former are also known, are so termed from a frill of inverted feathers extending downwards on each side from the back of the neck; in proportion to the size and regularity of this ruff is their value. Their colours vary, but

the head must always be clear white. Nuns are of smaller size, possessing only a hood; the distribution of their colours is very striking:—black head, the rest of their body being white, save only the flight feathers, and the extremities of the tail, which are tipped with black. Some white Trumpeters hooded and moustached with densely feathered feet; Barbs, with the scarlet ring around the eye; Tumblers, Baldpates, Almonds, and other shades, with a pair of Silver Owls, comprise a collection not often met with in provincial towns. One must wonder, indeed, that, for want of purchasers, even at most moderate prices, Mr. Fox is at times obliged, by increasing numbers, to sacrifice many for the purposes of his kitchen.

We have already stated, that Mr. Fox fears no injury, but rather the contrary, to his garden from his Bantams, which are at large; the same good deeds, though perhaps to a greater extent, are wrought, as regards slugs and such like nuisances, by his Aylesbury ducks, imported birds from Buckinghamshire during the last year. The same stream of water that affords a bath to the pigeons is happily just that depth which those curious in such matters say is best suited for those ducks who hereafter will appear upon our tables. Remember, then, this grand injunction, “never let a duck swim, it renders the legs inordinately hard.” So say the learned ones, and we believe them to be right.—W.

(To be continued.)

FUCHSIAS.

THE plants I wish to bloom in June and July are struck in August the previous year, potted in three-inch pots, and shifted from thence, in October, into six-inch pots, and kept near the glass, in a temperature of 50° or 55°; they are gently syringed over head occasionally, and carefully watered with tepid water until the middle of January, when they will be good strong plants.

They are then shifted at once into twelve-inch pots, with a compost of three-parts good fibry loam, one-part peat, and one-part rotten dung, with a good sprinkling of silver sand, all well-mixed together, but not sifted. The plants are then accommodated with a gentle bottom-heat, with abundance of air, maintaining the temperature mentioned above, and 5° or 10° higher, with sunshine, as the season advances. The branches are stopped at the fourth joint, and when they have broken and made four joints more, these are also stopped at the fourth joint, and again the third time in like manner, when they have advanced far enough. Then they are allowed to bloom.

Thus, by giving abundance of air, maintaining a moist atmosphere, syringing morning and evening, and after the plants are well established, supplying them with weak manure-water at EVERY watering, they will break in all directions, and will be one mass of bloom, and have beautiful shining foliage from the pot to the very summit of the plants. I have had them so treated attain to a height of nearly five feet through at the base, forming a splendid pyramid of bloom and foliage. One plant especially, when on the exhibition-table, was compared by one gentleman to “a mountain of bloom.”

Plants to bloom in August and September are struck in January, potted and grown the same way until June, when they are set out-of-doors on slates, in a sheltered situation, and well attended to with weak manure-water. How I prepare this is as follows:—I put a bushel of sheep or cow-dung, about half-a-peck of lime, and a spadefull or two of soot into a hogshead, fill it up with soft water, well stir it several times, and when it has settled down, I put about a quart to a bucket of water, which will make this about the colour of brandy.

If bloom-buds appear before I want them I pick them off. The plants are never shaded, except when in bloom. Often stopping, and high feeding, combined with abundance of air at all times, are the grand secrets of getting a mass of bloom and foliage. Generally, Fuschsias are driven into bloom too soon, and that is the cause why they cut such a sorry figure mostly. If a man would excel in the cultivation of the Fuchsia, there must be no lagging; no trusting the thing to another; but, the welfare of each

plant must be enquired after morning and evening.—A WILTSHIRE PRACTICAL MAN.

[We hope to hear from this correspondent often, and we recommend his excellent Fuchsia-culture to the attention of our readers.—ED. C. G.]

SHANGHAE FOWLS.

ONE of your correspondents, a short time since, suggested, that in endeavouring to form an estimate of the comparative merits of various breeds of poultry, we should regard them as "egg-making and meat-making machines." With reference to the first of these conditions, I think the verdict of such of your readers as keep Shanghae Fowls will vary somewhat; several having found that an excessive proneness to incubation in their stock detracts from their otherwise undoubted merit; while the fact of eggs by the bushel appearing to have been collected from the Shanghae pens at a season when fresh laid eggs are scarce, while other breeds seem to have returned a "beggarly account of empty boxes" at the various poultry shows, would appear to others pretty conclusive evidence of their pre-eminence in this valuable quality.

My own experience tends to prove that different families, or "strains" of pure Shanghaes vary as much in these characteristics as do Spanish, Dorking, or Game Fowls; inasmuch as I have hens that have never gone "broody" the year through; others that have done so after laying seventy-six eggs in a few more than the same number of consecutive days; while, again, others have only laid fifteen eggs before wishing to sit. And as I have noticed that each of these qualities has been perpetuated, to a greater or less degree, in such of their descendants as I have kept for stock, we may fairly infer that an "infusion of fresh blood" from stocks which possess the opposite quality to that which we wish to neutralise, will be found quite as efficacious as the manufacture of a mongrel race, suggested by others of your correspondents. As to their capacity for "meat-making machines," I think there can be no question as to their supremacy over all known varieties of poultry; and if the three following trials are accepted as evidence, they will be found tolerably conclusive on that head:—

	Weighed	lbs.	ozs.	..	Weighed	lbs.	ozs.
1. Cockerel	Nov. 17	8	8	..	Nov. 25	9	4
2. "	Nov. 29	5	4	..	Dec. 4	6	1½
3. "	Nov. 29	5	13	..	Dec. 4	6	11

They were weighed on the evening of each date; it results, therefore, that the first gained 12ozs. in eight, the other two 13½ozs. and 14ozs. in five clear days, or at the almost incredible rate of 20ozs. a week.

New, as regards the vexed question of their being voracious feeders, I have kept 120, from four to eight months old (when we may consider them as at their highest consuming power), at a cost of eight shillings a week; but even if "Gallus" had proved against them, to the most objectionable extent, that they are enormous consumers of food, he will admit, at all events, that they do not "put it into a bad skin," and that *this* consumptive tendency is of a far less heart-breaking character than that to which Spanish Fowls are notoriously subject.

Another question, I have noticed, seems a puzzle to several of your correspondents, viz., the extraordinary value set upon clear-necked light-colour birds. The only solution of the mystery they can arrive at appearing to be, the extreme difficulty of breeding them so. Now if this was the sole reason, it is a sufficient one, as the rarity of most things enhances their value; but I happened some time back to visit the poultry-yard of a gentleman, who had unlimited opportunity of importing the choicest specimens of their kind, and was shewn three hens, the plumage of which, on breast, back, and thighs, was a clear cream colour, the hackle, like threads of pale glistening gold, rivalling in brilliancy that of their lords (a privilege rarely granted to the softer sex among feathered tribes), and was informed that this variety is prized, even in China, as "high caste," added to which, they are, from their days of earliest chickenhood, presentable and loveable little pets, quite a contrast to the strange gawky looking objects Shanghae Chickens are re-

puted to be; and I think your readers will agree with me that their intrinsic beauty alone would warrant the high "fashion" they seem destined to attain to. SOL.

COST OF POULTRY FEEDING.

I HAVE seen stated, in some of the late numbers of your COTTAGE GARDENER, the relative consumption of food by Shanghae and Spanish fowls. These remarks have induced me to ascertain the cost of keeping a promiscuous stock; and I am glad to find the expense is less than I had anticipated, and much below what is generally believed. I have twenty-one birds, all, with the exception of two that I had as nursing mothers for my young broods, were hatched in May, and being now six months old will, I fancy, require as much food as older birds. Five of these, a cock and four hens, are the third in descent from a direct import from Shanghae; a cock and two hens, Speckled Dorkings; eleven Spanish, of pure breed; and the two old nurses; together twenty-one birds. The Spanish are fed by themselves, whilst the others mess together. The Shanghaes and Dorkings are large birds. The Spanish, by contrast, appear small; yet the quantity of food consumed daily is nearly the same by both lots, and so abundant, that when six Shanghae cocks of four months old were killed, their average weight, when *trussed for the spit*, was four pounds. I did not ascertain their live weights.

On the 24th of October, my bins being empty, I bought from a grain dealer,

2 stones, or 28 lbs. of Oats, which cost	-	2s.
Ditto do. Barley	-	2s.
Ditto do. Indian Meal	-	2s.
Small Potatoes	-	2s.

costing, together, eight shillings, which has served the fowls until last night, being thirty-two days; the twenty-one birds thus costing exactly one penny a head per week. This is satisfactory, showing how trifling the expense is of keeping a mixed stock.

It does not, nor was the experiment intended, to settle the disputed point of the relative expense of keeping large or small fowls. My birds, both lots, being fed alike as nearly as a guessed quantity, no weights being used, could be formed, are large and plump, and any day ready for the table.

My mode of feeding is—when the birds are let out, between seven and eight o'clock in the morning, they have oats for breakfast; at noon, boiled potatoes, mixed with Indian meal; and before going to roost, a feed of barley. The potatoes at noon are mixed, at times, with kitchen scraps; to which I attach no value, as if not thus used they would be thrown on the dunghill. The birds have the run of a grass field, which the Dorkings and Spanish much frequent, the Shanghaes remaining more contentedly within the shelter of a large paved yard.—IRON.

POULTRY SHOWS.

ALTHOUGH we gave so copious a report of *The Birmingham Poultry Show* in our last number, yet there are many facts connected with it that deserve notice. There were about five thousand birds assembled on the occasion, and of these £1300 worth were sold on the first day. The highest price we know of being given was £25 for Mr. Punchard's pair of buff Shanghae fowls (No. 408); and Captain Hornby sold his pen of four of the same variety (No. 272) for thirty guineas. *The Midland Counties Herald* justly remarks that these prices are not more contrasted with those given at the first Show in 1848, than are the Shows themselves. At that little show eight guineas were given for the pen which obtained the medal.

The arrangements of the Committee to facilitate business were all excellent, and can scarcely be improved upon, unless it be by a list, added to as sales are effected, being hung up outside the sale office, stating which pens are sold, and by a loud announcement of each sale in the office. This would prevent the disappointment attendant upon waiting for half an hour, and then finding that the lot desired had been sold whilst you were detained.

Since our publication of our condemnation of a dealer in poultry being a judge at a poultry show, we have received so many communications and queries respecting the Judges of the Birmingham Show, that we almost shrink from inserting any of them. Our duty as public journalists, however, must prevail, and we insert the following questions sent to us by a gentleman of high standing. No reply, no rejoinders, either affirmative or negative, shall be inserted, unless written courteously. We have but one object in view—that there shall be no foundation for suspicion of the decisions at Birmingham and other Poultry Shows. We shall pursue that object and our search after the truths needful to be elicited, and our pursuit shall be perfectly without asperity; those who differ from us must be similarly guarded, for we will have no literary ruffianism in our pages.

The questions sent to us are these:—

“Is it true that one of the judges at Birmingham this year, or his man, brought down the birds of the friend of another judge?”

“Is it true that these last received birds obtained a prize and a commendation?”

“Is it true that one of the judges was sending out catalogues on the Sunday before the Show?”

“How many catalogues were sent out before the Show, and to whom?”

“When did the judges arrive in Birmingham; and when did each of them first enter Bingley Hall?”

“Is it true, as publicly declared by one judge in the presence of another, that, in one class, the judges wished to give an extra prize, and that permission was refused to them to do so?”

“Is it true that an extra prize was given to a single bird in pen No. 923?”

“To whom did that bird belong?”

“When these queries have been answered, others may follow from “Q.-IN-THE-CORNER.”

To one of these questions we can answer, that Mr. Bailey, one of the judges, had a catalogue before the show, and sent it to one of our contributors. We do not blame him for that politeness, but we do say that no judge should have a catalogue sent to him until after he has made his award. As far as possible, the name of a proprietor of any pen should be unknown to any of the judges, and we think sending catalogues to them was a very great mistake, which should be avoided in future.

We have already fully explained ourselves relative to *The Great Metropolitan Poultry Show*, but we have since received a very polite letter from Henry Gilbert, Esq., from which the following is an extract:—

“A Metropolitan Show of Poultry having been long required, and mooted, without success, for several years, and not until after the Royal Agricultural Society had been frequently requested to associate it with the Smithfield Cattle Show at Baker-street, did a few spirited gentlemen amateurs come forward, with a large sum, to carry out, at great expense and trouble, the desired object; whether successfully, or unsuccessfully, for loss or for gain, remains to be proved; the latter was not anticipated. Such is the origin of the Great Metropolitan Exhibition. The list of noble patrons, who are personally known to some of the promoters, must be a sufficient guarantee for their respectability.

“No gain is derived from the sale of refreshments, as you have represented, “from some neighbouring innkeeper,” nor have the Horns Tavern anything to do with it, and is not even known to me, or the committee. That there will be refreshments I do not deny; so are there at Birmingham, and all other exhibitions where a large and respectable body of visitors is expected.

“The next point you notice unfairly, is the time the birds are exhibited. Again, Birmingham is our example, as we shall not keep them longer.”

After what we said last week, it is not needed that we make any further comment upon Mr. Gilbert's statements, than to observe, that he is quite right in observing that at the Metropolitan the birds will not be kept longer in the pens than at Birmingham. The obvious answer to this is, that two parties committing the same error do not make it a praiseworthy practice; and we are quite sure that Mr. Gilbert agrees with us in thinking that five days is too long a time to keep birds at an exhibition. We are not sure that

one of his birds did not die at Birmingham in 1851, and we know that one of Capt. Hornby's did this year; and we are certain that even the strongest constituted birds must suffer by the protracted excitement inseparable from exhibition by day, to say nothing of that by gas-light until a late hour at night. We are confident this will be avoided in future.

The *Salisbury Poultry Show* appeared to be still more popular than the other department of the Agricultural Exhibition, on the 13th of December, and was crowded throughout the day, a number of ladies testifying by their presence the interest they felt in this collection of domestic poultry.

Subjoined is the list of prizes:—

Class A.—SPANISH.

1. Captain W. Hornby, R. N., Knowsley Cottage, Prescott, Lancashire, Cock and three Hens, 5½ months, 1st prize, 1*l*.
3. T. Pain, Esq., Salisbury, Cock and two Hens, one year and seven months, 2nd prize, 10*s*.

Class B.—DORKINGS.

17. J. W. F. Noyes, Esq., Cock and two Hens, April, 1852, 1st prize, 1*l*.
18. Mr. C. Smith, Durnford, near Salisbury, Cock, seven months, and two Hens, 18 months, 2nd prize, 10*s*.

Class C.—COCHIN-CHINA.

20. H. I. J. Cockerham, Esq., Abington, Wilts, Cock and two Hens, hatched in May, 1st prize, 1*l*.
30. Mr. George Wheeler, Commercial Road, Southampton, Cock and two Hens, eight months, 2nd prize, 10*s*.

Class D.—MALAY.

36. A. C. Sayers, Esq., Clanville House, Andover, Cock and two Hens, one year (speckled), 1st prize, 1*l*.
39. Mr. W. H. Woodcock, Fugglestone, near Salisbury, Cock and two Hens, six months, 2nd prize, 10*s*.

Class E.—GAME.

43. Mr. H. Yates, King's Arms, Lockerly, Hants, Cock and two Hens, two years, 1st prize, 1*l*.
41. Mr. John Stratton, Bodenham, near Salisbury, Cock and two Hens, two years and six months, 2nd prize, 10*s*.

Class F.—GOLDEN-SPANGLED HAMBURGH.

No competition.

Class G.—SILVER-SPANGLED HAMBURGH.

45. W. G. Chambers, Esq., Portsmouth, Cock and one Hen, three years, and one Hen, eight months, 1st prize, 1*l*.
46. W. G. Chambers, Esq., Cock and one Hen, eight months, and one Hen, three years, 2nd prize, 10*s*.

Class H.—GOLDEN-PENCILLED HAMBURGH.

No entry.

Class I.—SILVER-PENCILLED HAMBURGH.

50. Mrs. Mills, Bisterne, Ringwood, Cock and two Hens, 18 months, 1st prize, 1*l*.

Class J.—POLAND.

52. Mr. T. P. Edwards, Lyndhurst Railway Station, Cock, eight months, two hens, two years, 1st prize, 1*l*.
53. Mr. T. P. Edwards, Cock and two Hens, seven months, 2nd prize, 10*s*.
54. Mrs. Mills, Bisterne, Ringwood, Cock and two Hens, 18 months, black, white crest, extra prize, 10*s*.

Class K.—ANY OTHER DISTINCT BREED.

- COMMENDED.—55. Mr. W. Cheyney, Barford Park, Downton, Wilts, Cock and two Hens (Game and Malay), 9 months.

Class N.—BANTAMS.

- No first prize.
65. Mr. W. H. Woodcock, Fugglestone, near Salisbury, Cock and two Hens, aged, 2nd prize, 10*s*.

Class M.—BANTAMS, WHITE, BLACK, OR ANY OTHER VARIETY.

67. Major-General Buckley, New Hall, Salisbury, Cock and two Hens, 1st prize, 1*l*.
72. Mrs. Mills, Bisterne, Ringwood, Cock and two Hens (white, single comb), 12 months, 2nd prize, 10*s*.

Class N.—GEESE.

78. Mr. C. Pinniger, Rockbourne, Hants, Gander and Goose, five years, 2nd prize, 10*s*.
 80. J. F. Hart, Esq., Gander and Goose, four years, 1st prize, 1*l*.
- In this Class a pen (No. 75) was exhibited by T. Pain, Esq., whose united ages amounted to 110 years, *i.e.*, a Gander 10, a Goose 40, and a ditto 60; which goes far to establish the fact of these birds reaching 100 years.

Class O.—DUCKS.

82. C. Penruddocke, Esq., Compton Park, Wilts, Drake and two Ducks, six months, 1st prize, 1*l*.
85. James North, Ford, Salisbury, Drake and two Ducks (black), six months, 2nd prize, 10*s*.

Class P.—TURKEYS.

94. Mr. W. Cheyney, Barford Park, Downton, Wilts, Turkey Cock and Hen, six months, 1st prize, 1*l*.
93. C. Penruddocke, Esq., Compton Park, Wilts, Turkey Cock and Hen, seven months, 2nd prize, 10*s*.

TO CORRESPONDENTS.

* * * We request that no one will write to the departmental writers of THE COTTAGE GARDENER. It gives them unjustifiable trouble and expense. All communications should be addressed "To the Editor of the Cottage Gardener, 2, Amen Corner, Paternoster Row, London."

IVY (X. Y. Z.).—There is no doubt whatever upon the point. Ivy keeps the wall dry which it covers.

POLMAISE HEATING (G. B. C.).—Polmaise, as a mode of heating, has seldom been so successful as hot-water. You will see an article by one of our correspondents in to-day's paper; if your house be treated in that way some nicety will be required in giving the necessary quantity of moisture to the air inside; but as you seem to have accomplished that, and supposing you can command the necessary amount of heat, there seems no reason to doubt but that the plan will succeed very well. You must be careful that the openings you have made for the escape of hot air be not in contact with the foliage; notwithstanding its being somewhat mellowed by moisture, it is often too violent to be safely trusted amongst tender plants.

VENTILATION (G. B. C.).—Ventilation, like many things else, has undergone a great revolution the last few years. One thing, however, the escape of impure and highly-heated air, at the highest part of the building, is still regarded as a necessary thing; but the admission of cold air at the opposite lowest extremity, or when in contact with the pipes, flues, or other heating apparatus, has hardly yet advanced so far as it ought to do towards perfection that way; but some of our departmental writers will be enlarging on that soon.

NAME OF AMERICAN APPLE (*Inquisitor*).—The small red and yellow apples packed in barrels from America are the *Lady Apple*. Other answers next week.

FLOWER-GARDEN PLAN (*Regular Subscriber*).—Your plan is only adapted for mixed planting—at least, the four large beds within the diamond should be so planted. The basket in the middle might be of one strong colour, as scarlet, or yellow, and bordered with white or pink, as, for instance, Tom Thumbs, White Ivy-leaved Geraniums, or Yellow Calceolarias, and Pink Ivy-leaved, or Mangles' Variegated Geranium. Without knowing the situation of the house, and the exact line of the Rhododendron beds, it would only be guess-work to say what kind of beds ought to occupy the rest of the ground; but as the shape of it is circular, that also would be the best shape for the beds. Even if we could point out the best situation for the extra beds, there is no index by which you could understand the positions; or, in other words, we have no data to make out your meaning, and no index to explain our own, if we did.

CAMELLIA BUDS TURNED BROWN (*Sarah*).—The reason why the Camellia buds change colour, and fall off, is either too much dryness in the air they breathe, or a very bad state of the roots, brought on by one or other of a dozen causes. If the roots are at fault, the plants must be repotted early next April, reducing the balls as much as possible; then smaller pots, a light compost of good loam and sand, with a little peat; and, as soon as growth is fairly set in, the plants ought to be pruned by a gardener of experience: no written directions will ever do for this kind of pruning.

OXALIS DEPPII NOT BLOOMING (*Ibid*).—You surely cannot have the right sort. We could not suggest a possible mode of preventing it flowering. If you make holes in a gravel walk with the end of your parasol, and place a root of this Oxalis in each, every one of them will flower; if you place it on the surface of a bed, it will make roots, leaves, and flowers; if you bury it six inches in rich soil it will come up and flower; or if you plant it in a bed of sand, or coal-ashes, it is just the same for the first flowers; but to flower well the year after it wants a bed of good garden mould, and to be kept dry during the winter. If you have any dry roots now, keep them so till the end of April; then plant them by the side of Crocuses. Water them now and then, if the summer is dry, and take them up in October, and after that they will do well.

LACED POLANDS.—*Scrutator* says—"As a constant reader of THE COTTAGE GARDENER, I have had the old spirit for poultry, which intoxicated me some twenty years ago, revived, although at the present time I do not possess a single specimen of the gallinaceous tribe. To such an extent has this feeling obtained, that I absolutely went from London on Tuesday to witness the exhibition of poultry at Birmingham, intent on renewing my acquaintance with either Gold or Silver-laced Poland (as the Rev. Mr. Dixon says they are not, or ought not to be, spangled). Having reached Bingley Hall at half-past nine, A.M., you may imagine my disappointment at finding not a single pen of well-laced birds, and, worse than all, to find that the judges knew nothing whatever of the points of excellence of my would-be-pets—the first prize for Silver Poland being literally a pen of spotted birds; and, in fact, one might almost suppose that lacing was inadmissible. Nothing could more completely justify your remarks that there ought to be separate judges for different breeds, and that the different points of excellence should be settled. To this end I would suggest to you the propriety of making a commencement in THE COTTAGE GARDENER; and should you approve of the suggestion, and would accept my humble opinion of the points of Gold and Silver Poland (having formerly been a fancier), I shall be only too happy to forward it, together with some feathers from different parts of really first-class birds. This would really be a move in the right direction, and would induce breeders of first-rate birds to exhibit, which at present they have little inclination to do, from the qualities not being understood. By-the-by, I observed that prizes were awarded to black Poland which had had the black feathers cut away from the anterior portion of their top-knots: this should not be." [We shall be much obliged by the proffered communication.—Ed. C. G.]

GLOXINIAS AND ACHIMENES (*A New Irish Subscriber*).—Your collection, comprising Spectabile, Victoria Regina, Princesse de Lamballe, Marie Van Houtte, Grande Duchesse Hélène, and General Baudaud, is very good. You will improve it by adding *G. alba grandiflora*, *G. grandis*, *G. carminata splendens*, *G. Fyfianna*, and *G. Passinghamii*.

The place where you keep them is too warm; that is the reason why they are now showing symptoms of growth, which they should not do, to flower finely in June. Place them in the coolest part of your stove; repot, and start them into growth about the beginning of February; give no water till the shoots appear, and then but slightly, gradually increasing it as the plants advance in growth. A shelf in your cooler orchid-house would be a good situation for them. *Achimenes* require the same treatment as Gloxinias, and the same time of starting to bloom in June. The following will suit you. We cannot give prices, but may say the whole are not dear:—*Achimenes Baumannia hirsuta*, *A. fimbriata*, *A. longiflora* major, *A. longiflora alba*, *A. grandiflora*, *A. Tugwelliana*, *A. venusta*.

MOST PROFITABLE RHUBARB (*A Northamptonshire Subscriber*).—The most profitable kind of Rhubarb is the *Victoria*, and the earliest is the *Prince Albert*. The best time to plant is October; but as that season is past, you may plant any time between this and March. If possible, let your ground be dry at the time. Send the advertisement, and then we can tell you the charge before we insert it.

BEES.—*A Country Curate* writes to us as follows:—"To 'Observer's' query, I would reply, that his experience, in respect to the bees of an old stock not leaving the parent hive in any numbers, when the stock had been removed to make way for the swarm, is by no means singular. A similar occurrence fell under my notice last summer. A box-hive in my apiary, with three large windows, now in the possession of a clerical friend near Gloucester, having been compelled to swarm on the 1st of June, was shifted from its original position, on the upper shelf of my American bee-house, to a vacant place on the same shelf, three feet distant. It was at first carefully closed, to prevent the issue of too many bees; but after repeated examinations of the interior condition of the hive, finding that the bees continued quiet, I opened the entrance; instead of the usual rush, however, only one or two flew out occasionally during the next two or three days, of which, however, not one in ten returned. I accounted for it in this way—that, in the first place, the young queens (of which there were two still unhatched in the box) were in a very forward state, which would have the effect of tranquillizing the bees, even though they missed their old queen-mother. The senior of these princesses, in fact, issued two or three days later, and is that queen alluded to in a former number of THE COTTAGE GARDENER, who, after continuing sterile for about a month, suddenly became prolific, and laid upwards of 750 eggs in two days. Secondly, I argued, there must evidently be a great proportion of quite young bees just hatched, that had not yet ventured much, if at all, abroad. At the end of four or five days, however, they became very active; a few dead nymphs were carried out, and the hive became as active as any in the apiary. Instances like the above may frequently occur; but, perhaps, in such cases, a combination of the above circumstances are necessary. Sometimes it happens that a hive is almost entirely deserted by the older bees, especially when a delayed prime-swarm issues. In this case, of course, there could not be expected a very numerous subsequent issue to rejoin the bees in the old stand, as what bees remained, would naturally gather round the infant brood of royalty, as well as be stupified by the rapidly-falling temperature of the hive, until the population has so much increased as to rouse them up again. I may add, that I have never possessed an observatory-hive, such as your correspondent speaks of."

LILIES (*J. B.*).—We should readily give you the desired information respecting your Lilies, but do not know what kind of Lilies you are speaking of. Send us a specimen of them, and we will set you right. Your plant sent, which was given you by an old gardener, is one of the best of plants for summer bedding-out in the flower-garden. It is a hardy, greenhouse, under shrub, and roots freely from cuttings. Its name is *Cælestina ageratoides*, or *Ageratum-like Cælestina*.

BACON HOPPER (*A Half-pay Officer*).—I suppose the Bacon Hopper is identical with the Cheese Hopper, *Piophilus casei* (see COTTAGE GARDENER, vol. 4, page 79); but it is curious that our Natural History Insect Books make no mention of its also attacking bacon. If your correspondent rears any flies, I shall be glad of a few specimens, as it may prove to be one of the other species of the same genus.—J. O. WESTWOOD.

ORCHARD.—If your forty-one trees are standards, that is, nearly six feet high in the stem, you may by all means plant dwarfs between, but do not depend on severe pruning for limitation; this is downright bad gardening. Make platforms not more than fifteen inches deep, to force the roots near the surface. We should get the trees on dwarfing-stocks, viz., Pears on the Quince, Apples on Paradise, &c. Mr. Rivers, of Sawbridgeworth, is highly to be relied on, for plants on the dwarfing system. Plant the following:—*Apples*.—Ashmead's Kernel, Lamb Abbey Pearmain, Braddick's Nonpariel, Hick's Fancy, Gooseberry Apple, Beauty of Kent, Pearson's Plate, Adams' Pearmain, Golden Reinette, Alfriston, Mank's Codlin, Kerry Pippin, Fearn's Pippin, William's Pippin, King of Pippins, Ribston Pippin, John Apple, Keswick Codlin, Dumelow's Seedling. *Pears*.—Beurré d'Amanlis, Ester Beurré, Dunmore, Capiamont, Glout Morceaux, Ne plus Meuris, Beurré Diel.

STRAWBERRIES (*A Constant Subscriber*).—Your strawberries will defeat the end in view; they cannot be forced early; might do for a frame in February.

LIST OF FRUIT TREES (*A Country Parson*).—For *Dessert Apples*: Williams' Pippin, Lamb Abbey Pearmain, Kerry Pippin. For *Kitchen Apples*: Dumelow's Seedling, Mank's Codlin, Beauty of Kent, Gooseberry Apple. *Five Sorts of Plums*.—For *Dessert*: Greengage and Golden Drop. And for *Tarts*: Washington, Magnum Bonum, and Orleans. Your *Hollyhocks* must be either too young, or hard-worn old plants, or the soil is weak.

GRAFTING ON UPPER SIDE OF BRANCHES (*Verax*).—It is almost immaterial how you put the scions in, so long as at least on one side bark meets bark once; consequently, the albuminous matter is well in contact. We, in the case of apples, pears, &c., simply cut off a slice, as in whip grafting, only horizontal instead of perpendicular, and make a slit, as in the whip mode, to steady the graft, taking care to fit one side, as before stated. The slice cut must be through the inner bark, and a little way into the wood; of course, a similar slice is cut from the scion. We believe that *Bon Louis Pear* is a very old and discarded variety. We

little doubt it is the original Louis Bonne of "London and Wise's Complete Gardener," where, at page 59, you will find a long account of it. This work is dated 1710.

ROSES (Ibid).—Will not *Felicite perpetuelle* do for your west wall? If your *Blairii*, No. 2, is like ours was last and the previous year, it will throw out bunches in plenty from the axillary buds in May and June. We simply prune away the immature points of the gross shoots in March, removing totally much of the old spray. We think it the best plan with the *Himalayan Conifers* to sow them immediately, in boxes containing a free loam in a moist state, and then to cover the boxes two inches deep with sphagnum, to supersede the necessity of watering if possible; for watering is apt to rot them in the act of germination.

PERIODICAL (S-U).—The work you name comes out monthly.

RABBITS (J. S. A.).—Our correspondent says he has a rabbit fancier these thirty years, and that he bred the longest eared rabbit ever known. He has her, for it was a doe, preserved in a glass-case. Her ears, from tip to tip, measured twenty-two inches, and each ear in width was five inches and three-eighths. Her weight 18lbs. We quite agree with you that a series of papers on the breeding and rearing of rabbits would be very useful, and if you will write them, we will publish them in **THE COTTAGE GARDENER**.

VINE BORDEE (J. W.).—If needed, a top dressing of guano, bone-dust, rape-cake, and limy rubbish, would make as good a compost as could be devised.

GREEN MILDEW.—L. C. says his house faces the north, and is constantly covered with green mildew. He would be obliged by any one saying what is a known remedy.

GOOSEBERRY AND CURRANT CATERPILLARS.—H. M., *Belfast*, would like to hear if any one has tried the applying of liquid manure to the roots of gooseberry and currant bushes, as a prevention to the ravages of the Caterpillar, and if so, with what success.

POTATOES (An Old Subscriber).—The *Ash-leaved Kidney* is early, prolific, and keeps well. Your potatoes to be were diseased being a late ripening variety, is enough to account for their being diseased, whilst the early ones escaped, although the ground for the latter was manured. At the same time, let us repeat, that general experience agrees that dung, or other stimulating manure, applied to the potato crop, increases the murrain upon it. An answer to your other query next week.

MUSK DUCKS (C. B. C.).—We cannot say where these are to be purchased. But see *Advertisement*.

WORK ON POULTRY (H. H., Dublin).—The work mentioned at p. 156, will be a separate publication, with coloured plates.

MALE BLOSSOMS OF CUCUMBERS (Claude Melnotte).—In reply to your enquiry whether Mr. Rust is correct in his practice, stated at page 187, in taking off "all male blossoms, as they are of no use, except when seed is required," we will reprint the testimony we gathered together some years since. That impregnation is absolutely required, where seed is to be obtained, no one disputes. Mr. W. P. Ayres says, that so far as the production of fruit is concerned, impregnation is "neither good nor harm," and cites, in proof of this, a brace of fruit, which he cut on the 8th of February, 1840, each nineteen inches long, which had never been impregnated; for, at the time the female flowers expanded, there was not a male blossom on the premises, and consequently no impregnation could take place. Since that time he has cut hundreds of fruit, the flowers of which never expanded, and the same has been done by several of his acquaintances. In fact, Mr. Wilson, Mr. Spivey, Mr. Judd, and the Messrs. Ayres, will undertake to procure, at the *May fete* of the Horticultural Society, from ten to twenty brace of fruit, as good as can be obtained by impregnation, the flowers of which shall be removed from the fruit before there is any chance of their being impregnated. Where long fruit is desired, Mr. Ayres thinks impregnation positively injurious, because, if seed is the result of impregnation, the energy of the plant will be expended in perfecting the seed, instead of in the production of fruit, as every practical man knows that the production of one seed from it will weaken the plant more than a dozen fruit fit for table. There are instances in nature of plants perfecting their fruit without impregnation, as in the different varieties of figs; and why not the cucumber do the same? Another practical gardener, Mr. Kyle, says, some years ago, as he was pegging down some plants, he broke the flower off the fruit, at least four or five days before it would have expanded. He left it, however, and, to his agreeable surprise, it swelled off as handsome a fruit as any he had during that season. From that time he has never taken the least trouble respecting impregnation, unless when wanting to save seed. Mr. W. Charlton gives similar testimony, for he says, some of the finest fruit he ever grew never opened a blossom. In one instance, he broke off the unexpanded corolla, and the end of the fruit, notwithstanding which the fruit swelled, and was eaten at table (*Gard. Chron.*). Such testimony as this is unimpeachable as far as it can possibly be carried; which is no more than this, cucumbers unimpregnated have been known to attain a good size and perfection. But it by no means refutes the opinion, that, to be most certain of a fruit not falling immaturely, one condition is that it should be impregnated.

OUT-MANŒUVERING THE SPARROWS.—N. W. M. says—"The following hint may be acceptable to some of your readers. I reside a short distance out of Dublin, and am infested with an innumerable quantity of sparrows, who contend with my fowls for the food thrown to them. I feed my fowls principally on oats, one-fourth of which was, I conceive, daily consumed by the sparrows; it was useless to think of driving them away. I only frightened my cocks and hens, who took greatly longer to return to the food than the said sparrows. Lately, I was obliged to get my oats bruised, as my horse, like myself, is getting old, and, to my joy, I find that I have completely nonplussed the sparrows. You are aware the sparrow always shells the oat; in its bruised state they find this impossible; and they now content themselves with the few oats that happen to have lost the shell; and since I commenced with the bruised oats, I have not one sparrow for the dozens I had hitherto, while my fowls seem equally well pleased with the oats in the bruised state."

SALE OF COCHINS (Le Chant du Cochet).—We cannot publish what you ask; the birds, though good, were not of sufficient mark to claim the

distinction. The catalogue gives you the pedigrees, and your stud book should be always in your pocket.

NAMES OF PLANTS (Novice).—Your Orchids are, No. 1, *Sophranitis cernua*; and, No. 2, *Dendrobium moniliforme*. No. 3, *Lycopodium denticulatum*. No. 4, *Satureja montana*, or Winter Savory. (B. B.)—Your white flower, we think, is *Epacris hyacinthiflora*; and the leathery-leaved one *Piper glabrum*.

CALENDAR FOR JANUARY.

ORCHID HOUSE.

AERIDES, Saccolabiums, Vandas, and such-like Indian plants, give water to once during the month. **AIR.** In this first month of the year we frequently have severe frosty nights, and clear, bright, sunny days. The heat necessary to keep out the frost, and the bright sun, will raise the temperature of the house too high; to lower it to the right pitch air must be given, and the apertures to give air ought to be so placed that the cold air does not rush in directly upon or through the plants. The best place for the openings is directly opposite the pipes; the air then becomes heated in a degree before it reaches the plants. **BLOCKS:** plants on these will require attention; any that are loose should be refastened; cleanse the leaves and pseudo-bulbs from green scurf and all kinds of insects. **CYRTOPIDIUMS,** see to; if any fresh growth is observable, repot in a rich compost. **DENDROBIUMS,** remove into a cool house; such as show growth may be potted and kept moderately moist. **HEAT:** keep both the houses to the lowest point of heat for the first half of the month; as the days lengthen allow the heat to increase a few degrees. **INSECTS,** continue to destroy. **MOISTURE:** on sunny days sprinkle the walks, walls, and pipes, two or three times a day. **PHAIUS GRANDIFLORUS,** now flowering, give plenty of water, and, if convenient, plunge the pots in a bed of heated leaves, or tanner's bark. **POTTING,** continue to perform upon all orchids beginning to grow. **SOILS,** procure, such as fibrous peat and turfy loam; lay them in a place to dry, to be ready for the general potting next month. **SORRALIAS,** place in a cool house; heat 55° by day, and 50° by night; cut down all the shoots that flowered the preceding summer to allow room for the young shoots; keep them quite dry while at rest. **STANHOPEAS** in baskets, if growing, dip in tepid water. **SYRINGE** blocks, as directed last month. **WATER** at the roots, apply carefully; do not wet the young shoots. T. APPLEBY.

PLANT STOVE.

See last month. Prepare a hotbed, &c., to strike *cuttings* in. **CLIMBERS** beginning to grow, tie in. **ERANTHEMUMS,** and other winter-flowering plants, give manure water to occasionally. Turn *tan-beds*, and renew the heat by adding fresh bark. **POT** a second batch of *Achimenes, Gesneras,* and *Gloxinias,* to succeed those done last month. Give moderate supplies of water till they begin to grow. The heat of this house must still be kept low, as too much excitement will, for want of light, cause the plants to grow weak, and the young leaves to come yellow. **SEEDS** of stove plants, sow, &c., giving only one watering till they begin to appear. Hard-shelled seeds steep in water heated to 180° or 200°; leave them till the water cools. **SPONGE** all large leaves, to clear off dust and insects. **SURFACE-STIR** the earth in pots, and clear off weeds and moss, and add a top-dressing of fresh compost. T. APPLEBY.

FLORISTS' FLOWERS.

AIR. Whenever the sun overcomes the frost draw off the lights, it will refresh the plants much; if kept on the plants will begin to grow, and will be more liable to suffer from close covering during severe weather. In dull, humid, mild weather, give air at the back or sides by tilting up the lights. **ANEMONES** may yet be planted; choose a dry day for the purpose; cover the tubers with a thin layer of white sand. **AURICULAS** and **POLYANTHUSES,** dress off decayed leaves; search for slugs in the frames and under the pots. **CARNATIONS** and **PICOTEES,** water when dry; pick off decayed leaves. Any leaves not decaying, but showing spots on them, remove; it is the plague of these plants. **CHRY-SANTHEMUMS** now partially at rest, water once; any advanced shoots cut off, and make cuttings of; those out-of-doors place a slight covering of tanner's bark round, to protect them from frost. **CINERARIAS** will now be showing flower; water when dry; pot seedlings; repot young, small plants, struck late, to encourage growth. **CALCEOLARIA** seedlings, pot off from pans; repot young plants; give plenty of air to; smoke frequently, to destroy green fly; attend closely to watering, and avoid wetting the leaves; pick off daily all decaying leaves, and clear the surface of the soil of moss. These are, as the term is, *miffy* plants, and soon lost, without great care through this month. As the frost in this month is often very severe, apply COVERINGS of sufficient thickness to keep it out; light, open material, such as fern or straw, with a single mat over it to prevent it blowing about, is better than a covering of three mats laid close upon each other. **DAHLIAS,** examine, and clear away all decaying tops or bulbs; any roots quite gone throw out at once. **FUCHSIAS:** as soon as shoots are made half-an-inch long, slip them off, and put them in sand under hand-glasses to strike; these early short cuttings, or slips, strike easily and quickly. **HOLLYHOCKS:** should the weather be open, plant them out; if not already done, the sooner this is done the better chance there is to have a good bloom. Use hoops and mats over the **TULIP** and **HYACINTH** BEDS in severe frosty or heavy rainy weather. **LOBELIAS** (Tall), keep from severe frost, and moderately dry. **PANSIES** in pots, look to, and water gently when dry; search frequently for slugs; those in the open air, in mild weather close the earth (loosened by frost) to the plants; if open weather, give a top-dressing of decayed leaves and a little soot. **PINKS:** after the frost is gone press the soil to with the hand firmly, or they will be thrown quite out of the ground. **RANUNCULUSES** may be planted, weather permitting, the last week in

the month (see former number of THE COTTAGE GARDENER as to the manner); water, give none in frosty weather, but as soon as a change takes place apply it early in the morning of a fine day. VERBENAS, give air to; trim off decaying leaves and mould; stop such as are growing and drawing up weak.

T. APPELEY.

FLOWER GARDEN.

ANNUALS in borders, keep free from fallen leaves or other litter; and, if the weather is fine, sow a few more at the end of the month. BULBS, see that mice or rats do not get to them: fresh soot keeps them off for awhile. CUTTINGS, of various hardy deciduous shrubs, climbing roses, and the like, may yet be put in. EDGINGS, see that they are in good order; slate edgings are the best, then box: either may be laid this month. If the soil is dry at the end of the month, plant some GLADIOLI, such as *Psittacinus*, *Gandavensis*, and their varieties, and continue in monthly succession to the end of April. Forget not to procure such *stakes*, *rods*, *pegs*, and *tallies*, as may be wanted next summer, in time. Destroy *rats*, *mice*, and other creatures destructive to seeds and roots. Again look at the protected plants, to see they are dry. GRASS, keep it clean and well rolled. HEDGES, evergreen and otherwise, may yet be planted and dressed. LAYERS of evergreens, or deciduous shrubs, may be made as the borders are cleaned. MANURE, in composts, apply to such flower-beds as may require assistance; and in a solid, rotten state to all roses. MULCH all newly-planted trees, &c. POTTED PLANTS in reserve garden secure from frosts. PLANTING, push forward in mild weather. PRIVET, make cuttings of the young shoots for increase. PRUNE and regulate every tree or bush which requires it; be more sparing with evergreens. RANUNCULUSES, if the soil be dry, plant a lot for another succession. ROSES, prune, plant, and dung, if not already done; protect *Tea* and young *Bourbons*; and wash them with strong lime and soot paint, to kill moss and insects. SEEDLINGS, and all young plants, protect according to their hardihood and strength. SUCKERS, pull up and destroy, unless wanted for increase, as those of some roses, &c. TRENCH vacant ground. WALKS, roll as soon as they are dry, after rains or frost, and keep them regularly cleaned. WEEDS, destroy everywhere. WHEELING, reserve for frosty or very dry weather. Four times, within our memory, after unusual mild weather to the middle of January, we experienced severe frost and rough weather; provide against another of these trials in time, and see that everything is ready for securing a supply of ICE at the first opportunity.

D. BEATON.

ORCHARD.

APPLES, cleanse from blight, moss, &c.; brine and soft soap are good for such purpose. BUSH-FRUIT, plant, prune. COMPOSTS, procure and prepare. CHERRIES, plant, prune. CUTTINGS, plant of Gooseberries. Currants, &c. CHESTNUTS, plant. DRESS all borders. FIGS, protect. FRUIT-ROOM, look over weekly; be sparing in giving air; remove decaying fruit, and keep the room dark. FILBERTS, plant. FORK, borders. GOOSEBERRIES, plant, prune. LAYERS, make. LOAM, procure for stations. MULCHING, perform. MULBERRIES, plant. MEDLARS, plant. NAILS and Shreds, dress. NECTARINES: See *Peaches*. PLUMS, plant, prune. PEARS, plant; prune ordinary kinds. PEACHES, plant, prune, train, and dress. PLANTING in general proceed with. STATIONS, make. TRAINING in general proceed with. TRENCHING, carry on. TREES, stake. VINES, prune and train. WALNUTS, plant. WALL-TREES, in general prune and regulate. WASH, the following, may be applied to walls: two-parts soot, two-parts sulphur, four-parts lime, applied with a brush into every crevice; urine or soap-suds, or both, may be employed to mix with.

R. ERRINGTON.

FORCING-HOUSE.

AIR: See *Ventilation*. ASPARAGUS, get out succession-beds on mild heat. APRICOTS: See *Peach*. BOTTOM-HEATS, sustain and assist, 72° to 78°. CUCUMBERS, top, dress, train. CHERRIES: See *Peach*. COVERINGS, use where possible, to save fire-heat, and to protect from extremes. FIGS: See *Peach*. FIRES, use discreetly. GLASS, wash all roofs. GRAPES, ripe, use fires and air liberally, remove decaying berries. INSECTS, extirpate; use fumigation, the sponge, and soft soap. KIDNEY-BEANS, pot, and provide successions. NECTARINES and *Peaches*, in bloom, air liberally, and shake to disperse the pollen. MUSHROOMS, protect well, if out doors; in house, use much water on floors. PINES, continue to sustain proper heat to, cover well in dung-pits, and remove linings. PEACHES: See *Nectarines*. ROOTS, protect in boxes, tubs, &c. STRAWBERRIES, give air and light, use liquid-manure where blossoming; introduce successions. TARRAGON and other herbs, introduce to heat. VENTILATE as freely as you dare. VINERY (Early), proceed steadily; keep a moist air; raise the heat at blooming-time; use sulphur against mildew. WATER, always use in a tepid state.

R. ERRINGTON.

GREENHOUSE.

AIR, admit at every favourable opportunity, whenever the temperature outside is above 35°, except in windy or foggy weather, especially among Heaths, Epacris, and Azaleas that you do not wish to bloom early. In foggy weather, though warm, it will be advisable to put on a little fire, to change the visible to invisible vapour. If the fog was of short continuance, and could be kept out of the house, air might be dispensed with, as well as fires, though it should not be forgotten that the motion given to the air by a little firing is a great security for the health of the plants in dull weather. Soft-wooded plants should be kept at one end of the house. BULBS and hardy SHRUBS, such as Lilacs, Azaleas, and Roses, introduce from the forcing-house, placing them at the closest and warmest end of the house; Calceolarias, Cinerarias, Geraniums, and Chinese Primroses, clean, shift, and supply at times with manure-water. CAMELLIAS and CYTISUSES opening their buds, supply with manure-water. CLIMBERS, prune in, if not already done, those that produce their flowers on the young wood; others, such as *Kennedya*, now flowering and growing, attend to; and especially train, every day, the *Tropeolums*, if you wish to prevent confusion. No time should be lost

in potting such kinds as *Tricolorum*, *Jarrattii*, *Speciosa*, *Azorea*, &c., if not already done. FIRES, light in close, dull weather, to enable you to give a circulation of air. Beware of heating too much when frosty, as, without due precaution, the atmosphere will be too dry; it is better to use coverings for the glass. This is more particularly to be attended to, after the dull moist weather we have had. FUCHSIAS: the forwardest may now be pruned and repotted. GERANIUMS and CINERARIAS will, in all likelihood, want cleaning and fumigating. The first may now be repotted for late May and early June blooming, and the latter must be shifted and kept growing, so as to prevent them throwing up flower-stalks, if late bloom and large specimens are desired. Where room is limited, a fine display is obtained by successions, and using not larger than six-inch pots. Not a withered leaf, nor an *aphis*, should stand longer than when seen. When the fly covers a leaf in myriads, smoking with tobacco then, is tantamount to labour and money thrown away. ROSES in pots, for April and May and June blooming, in the greenhouse, finish pruning; wash with a paint of soot, sulphur, and clay; top-dress with rich compost; and plunge, if possible, in a house or pit—sawdust will be a good material—and give at first a temperature of 40° to 45° at night, and from 45° to 55° during the day. SUCCULENTS, unless growing and showing flower, refrain from watering. *Tropeolum Lobbianum*, and *Manettia bicolor*, will be great ornaments now, in a warmish dry greenhouse. WATER plants only when requisite, and perform the operation after breakfast, using water rather higher than the medium temperature of the house. Place a few Achimenes, Gesnera, and Gloxinia roots into heat for early blooming. In a conservatory or greenhouse, where no hard-wooded plants to speak of are grown, and where a medium heat of 50° can be maintained—that is, 45° at night, and 55° during the day—*Poinsettia pulcherrima*, *Euphorbia Jacquiniflora*, &c., may be introduced from the stove. For the *Poinsettia* especially, if a little extra heat can be given in April, a close cold pit in summer, an average night temperature of 50° in October, and a medium of from 45° to 55° in winter, nothing can surpass the brilliance of the large crimson floral leaves, for a couple of months, at this period, while the brilliancy remains longer in such a house, than in a plant stove. (See *Calendar of last month*.)

R. FISH.

KITCHEN-GARDEN.

ARTICHOKES, attend to, shelter, &c. ASPARAGUS, plant in hotbed; attend to that forcing; temperature about 65°, and at night 50°. BEANS, plant, b.; earth-stir among often; advancing crops protect from frost; plant in hotbed, if required. BEET (red), plant for seed. BROCOLI, protect from frost. CABBAGES, plant, e.; sow, e.; plant for seed. CARDOONS, attend to, shelter, &c. CARROTS, sow small crop; plant for seed; (early Horn) sow on gentle hotbeds, fill the frame up well with earth, so as to bring the crop up close to the glass; attend to early thinning-out, and earth-stirring with a little pointed stick among all frame crops. CAULIFLOWERS in frames, attend to protection from frost, and give all open air possible in open weather, by taking the lights entirely off; also, hand-glass crops, clear away all decayed leaves and slugs, and earth-stir often; if young plants are required, a pinch of seed may be sown in pans, and placed in any heated structure, but have a gentle hotbed made up ready to prick them out upon, keeping the young crop up close to the glass. CELERY, earth up, shelter, &c. COMPOSTS, prepare and turn over. CUCUMBERS, sow and prick out; temperature, by day, 70° to 75°, and at night 65°. DUNG, for hotbeds, prepare in earnest; wheel on to vacant ground. EARTH for hotbeds, prepare. EARTH-STIR, and fasten plants disturbed by frost, &c. ENDIVE, blanch, protect. FROST, protect plants from, by temporary covering. GROUND, trench vacant. HORSE-RADISH, plant at any time during the month in open weather. HOTBEDS, make and attend to. JERUSALEM ARTICHOKES, take up and replant in open weather, at any time during the month. KIDNEY-BEANS, sow in succession in hotbed, &c. KALE (Sea), attend to; force in succession. LETTUICES, in frames, attend; protect from frost; sow on warm border, e. LIQUORICE, plant, e., and dig up three-year-old. MELONS, sow, for fruiting in May; day temperature 75°, night 65°. MINT, force, in hotbed. MUSHROOM BEDS, make, and attend to those producing; procure horse-droppings for. MUSTARD and CRESS, sow in hotbed. ONIONS, clear from weeds; examine stored; sow a small crop, e.; plant for seed. PARSLEY, sow, e.; protect from frost. PARSNIPS, plant for seed. PEAS, protect from birds by straining a single string of worsted along over the row; attend to the early pea sowing as near the first of the month as possible. It is a good maxim to always have a mouse trap or two set about the pea quarters. Sow; earth-stir; shelter from frost; and prepare sticks. This is a good season for making main sowings of early and second early peas where the soil works well and the weather is open. POTATOES, plant in slight hotbed; and they may also be planted out in the open border, or quarters, in fine open weather, where the soil works well. Examine those in the store. RADISHES, sow, in hotbed; thin out as soon as the plants can be handled, and sift a little dry earth among them; sow in border, e. RAPE (for salading), sow in hotbed; (edible-rooted,) sow. RHEUBARB, attend to; force, either in pots, to be planted in some heated structure, or covered up with pots or tubs and fermenting materials. SALADING (Small), sow. SAVOYS, plant for seed. SPINACH, keep clear from weeds and fallen leaves; make a small sowing toward the end of the month. TANSY, plant in hotbed. TARRAGON, plant in hotbed. TURNIPS, plant for seed; should the weather seem inclined to set in severe, store in a good supply, or heap them and cover them over with coal-ashes. WEEDS, continually destroy, and do any work which will lessen that of the following busier months; in particular, such as planting all the main out-door crops of potatoes, wherever the soil will allow of it, and the weather is favourable. WOOD-LICE, destroy in the mushroom-house by trapping under dry hay, and scalding it in hot-water; or by baiting small pots with boiled potatoes, or slices of potatoes under dry moss.

T. WEAVER.

WEEKLY CALENDAR.

M D	W D	JANUARY 6—12, 1853.	WEATHER NEAR LONDON IN 1851.				Sun Rises.	Sun Sets.	Moon R. & S.	Moon's Age.	Clock aft. Sun.	Day of Year.
			Barometer.	Thermo.	Wind.	Rain in In.						
6	TH	EPIPHANY. Twelfth Day.	29.919—29.787	49—35	S.	—	7 a. 8	5 a. 4	4 24	26	6 15	6
7	F	Acilius sulcatus; ponds.	29.805—29.508	49—27	S.W.	06	7	6	5 48	27	6 42	7
8	S	Dyticus marginalis; ponds.	29.863—29.181	49—32	S.W.	09	7	8	7 5	28	7 7	8
9	SUN	1 SUNDAY AFTER EPIPHANY.	29.460—29.148	39—26	S.W.	—	6	9	sets.	☾	7 32	9
10	M	Dyticus punctulatus; ponds.	29.714—29.663	50—25	W.	08	5	11	5 a. 2	1	7 57	10
11	TU	Hydrous piceus; ponds.	29.210—29.022	51—43	W.	07	5	12	6 18	2	8 21	11
12	W	Sarrotrium muticum.	29.326—29.151	54—36	S.W.	62	4	13	7 34	3	8 44	12

METEOROLOGY OF THE WEEK.—At Chiswick, from observations during the last twenty-five years, the average highest and lowest temperatures of these days are 40.2° and 30.3° respectively. The greatest heat, 54°, occurred on the 7th in 1845; and the lowest cold, 6°, on the 8th in 1841. During the period 113 days were fine, and on 69 rain fell.

BRITISH WILD FLOWERS.

POPPY-WORTS.—PAPAVERACEÆ.

PAPAVER. POPPY.

(Continued from page 215.)

Section II.—Poppies with smooth capsules.

PAPAVER DUBIUM: Long Smooth-headed Poppy.



Description.—This is an annual, and so much resembling the species which we shall next describe, *P. rhæas*, as to be frequently mistaken for it. *Stem* many-flowered, about two feet high, woolly at the lower part, but more bristly towards the top, the bristles on the seed-vessel stalks lying close to them, and whilst young of a beautiful silvery appearance. *Leaves* doubly pinnatifid, with the edges and mid-ribs hairy. *Capsule* or seed-vessel smooth, length much greater than the breadth, wider at the top than at the lower part, angular; rays of the stigma on its summit from six to ten. As the capsule ripens its lower part separates from the lid sufficiently to allow the ripe seed to escape without their being exposed to wet in the capsule. *Petals* broader than they are long, light scarlet, but paler than those of any other of our red Poppies. *Stamens* line-like; *pollen* yellow.

Places where found.—In fields where the soil is sandy.

Time of flowering.—June and July.

History.—Its name *dubium*, doubtful, alludes to the uncertainty at first felt whether it differed from *P. rhæas*, but

the doubt no longer is entertained. Jacquin has described a white-flowered variety having a dark purple spot at the bottom of each petal, but this has never been discovered in Britain. About Shanklin Chine, and other parts of the Isle of Wight, is found a very hairy, or shaggy variety, as represented in Christian's *Flora Danica*, 902. The *calyx* is studded with large transparent globules, with a bristle springing from out of each. The capsule is nearly twice as long as it is broad, being longer than in *P. rhæas*, but shorter than in the species, *P. dubium*. (*Withering. Martyn. Smith.*)

PAPAVER RHÆAS: Corn Poppy; Red Poppy.

Description.—This, the commonest of all the Poppies, is an annual. *Stem* from one to two feet high, upright, cylindrical, branched, purplish at the lower part, clothed with spreading tawny-coloured hairs, having bulb-like bottoms. *Leaves* stalkless, rather sheathing the stem, hairy on both sides, pinnatifid, with the segments unequally toothed, each tooth rolled back at the edge, horny at the top, and ending in a small spine. *Flower-stalks* long, cylindrical, upright, single-flowered, clothed with hairs spreading horizontally. The two sepals of the *Calyx* bristly, and skin-like on the edges. *Petals* bright scarlet, often black at the bottom. *Capsule* urn-shaped, smooth, with a convex stigma, purplish, and ten or twelve-rayed. Capsule marked with as many raised lines as there are rays to the stigma. *Seeds* dark purple.

Places where found.—In fields everywhere, being a troublesome weed.

Time of flowering.—June and July.

History.—*Rhæas* is the Greek for a wild Poppy, and of them all this is the most common all over Europe. In this country its universal prevalence has subjected it to various local names, among which are Corn-rose, Cop or Cup-rose, Canker-rose, Red-weed, Head-wark, Red-mailkes, &c. In Shropshire and Staffordshire it is said to be very rare, its place being taken by *P. dubium*. Garden culture has raised from it many beautiful varieties, all of which, as well as their parent, are remarkable for their large flowers being packed so compactly as to be contained in a comparatively small flower-bud. From the petals of the wild species the Draper Bee (*Apis papaveris*) prepares the hangings of her apartment. She dexterously cuts out the petals when about half-expanded, straitens their folds, shapes them to her purpose, and lines with them the cell that is to be the abode of her offspring.

The petals of this Poppy give out, when soaked in water, a beautiful crimson colour, which is named from them *Coquelicot*—this being the French name for the flower. The petals have a narcotic smell, and a slightly bitter taste. When dried they have a wine-red colour. The drying is effected with difficulty, and when dried they must be kept in a very dry place. They are chiefly used in making Syrup of Red Poppies, which may have a very slight soothing effect; and foreign medical men prefer to opium an extract from the capsules of this plant. (*Martyn. Withering. Smith. Duncan.*)

IN whatever degree, either as regards mere numbers, or their relative merits, the Poultry Exhibitions of the year 1852 may have exceeded those of 1851, there can be little doubt but that 1853 will witness a still further

increase of the public interest that has hitherto been so liberally accorded to them.

With this prospect before us, it may be useful to consider how far our present arrangements for these

shows may be capable of improvement, so as to render them still more effective, in promoting the general introduction of better breeds of domestic poultry.

Apart from all controversy, as to whether Shanghaes, Spanish, or Dorkings, may prove the most economical race for general purposes, it is evident that mere fancy, and the gratification of individual taste, would long ago have failed to support the present ardour for poultry-keeping, had not the further inducement of a good return for money so invested been realized wherever judgment and attention were duly combined. If ten guineas, twenty guineas, and thirty guineas were readily paid at Birmingham, for the choicer pens of Shanghaes, the ticket "*Sold*," was also appended to a very large majority of the Dorkings, and with an eagerness, too, that showed that the original outlay, though merely for farm-yard stock, was regarded as a profitable investment. Thus Game Fowls, the different varieties of Hamburgs, Geese, Turkeys, and Ducks all participated in the general verdict of approbation passed on that occasion, and which stamped that Exhibition with the character of practical utility. The most economical production of eggs and fat chickens, then, appeared to be no less the calculation of buyers, than symmetry of form and beauty of plumage.

The column of THE COTTAGE GARDENER, which may contain the Exhibition days of the Poultry Societies for the present year, 1853, will, therefore, we anticipate, be greatly extended. But, at the same time, care should be taken not too far to subdivide the districts which are to be included within the area of the several operations. Such subdivision is an error the more to be guarded against, since its ill effects have long been visible in the case of many local Agricultural Societies, where they have so multiplied, that towns in the immediate vicinity of each other have each their separate meeting. The objections referable to the one case are equally applicable to the other; and not to go through what might be made a long catalogue of errors in such practice, it will be sufficient for our present purpose to observe, that in such cases, stock, whether Oxen, Sheep, Pigs, Horses, or Poultry, labour under the disadvantage, that instead of being placed in comparison with the picked birds of adjoining counties, they are, in too many cases, competitors only with their near neighbours. The consequence is inevitable, and in Agricultural Societies has been very generally admitted. Exhibitors, if victorious, are too apt to rest satisfied with their local laurels, while, if unsuccessful, they aim at no higher mark than their more fortunate neighbour has already attained to. In either instance, that progressive improvement, which year after year should bring about, is wanting, and one most important end in the institution of these Associations falls to the ground. Hence the great advantage of a meeting such as that which has just been held at Birmingham. Not one county only, not even the Northern, Southern, Midland, Eastern, or Western divisions of England, were there alone represented, but from Cornwall to Essex, and from Hampshire to Yorkshire, competitors of high caste entered the

lists. The victors in such an assemblage may well, therefore, be regarded as models for our present imitation, whatever further development of excellence future years may effect. Every poultry-keeper, therefore, would find it answer his purpose to make a yearly excursion to Birmingham, or some of the other large exhibitions, and if, hitherto, he has thought sufficiently well of his own or his neighbour's stock, he will probably, on his return from thence, admit that improvement is at least possible; however previously unwilling to believe that such could be the case.

The conclusion of the present year, we are told, is likely to witness the institution of a Metropolitan Poultry Show at the Baker-street Bazaar, under the most favourable auspices both as to patronage and exhibitors. No locality can be better suited for this purpose, and under good management it can hardly fail of success. But wherever new Societies are, or soon may be in course of formation, it will be but prudent on the part of those who are interested in them, to consider that one great element of success will depend on the area chosen for their operations. Now, speaking generally, if each English county had one such annual meeting, the interest and success of poultry-keepers would, we believe, be best advanced. Some, indeed, of the larger counties, such as Yorkshire, Cornwall, and Devonshire, might be divided, but Rutland and the smaller counties might be united with adjoining ones, and the total would thus remain about the same. There would be many advantages from such an arrangement, which would occupy too long a space for the present enquiry; the one objection, however, to which alone we have now adverted, is at least worthy of our best consideration.

Let us now turn to another point. The time of holding these meetings, November and December, will, of course, be the months most to be desired for this purpose, and for "*County*" Shows, if we may use this term as distinguished from the Birmingham and the future Metropolitan, it will be desirable so to arrange both that they may not clash in points of time, as also that just such an interval may intervene between them that birds exhibited at the one, may best be enabled to be presentable at the other. In counties far distant from each other this may not be generally necessary; but in fixing their days it will be prudent, on the part of the managers, to select such as may not interfere with either that at Baker-street, or Birmingham; for, however little they might themselves care for coming into competition with these formidable bodies, they would often find their best birds gone in that direction, and their admission money also fall far short of what otherwise might have been the receipts. Whatever, indeed, we may individually think of these matters, it will be an act of prudence, no less than of courtesy, to give precedence in these two instances. Birmingham, especially, has done much for the poultry-world, and we should not prove ungrateful, even if competition in this respect were not out of the question, as regarded our own finances.

Exhibitions for *Chickens only*, to be held in August, or the early part of September, are, we believe, in contemplation, and the "Cornwall Society" will probably try the experiment in the course of the year 1853. For such young birds distance would be a most serious objection, and the smaller districts, which might be unable to muster a sufficient number of pens for the regular annual contest for birds of all ages, might thus gain an excellent opportunity for comparing the progress of their different poultry-yards; the more so, indeed, as the younger members would suffer no depreciation from the presence of their seniors. At any rate, it will be worth consideration how far such a scheme might be carried into effect, since it would certainly aid in a very material degree in adding to our knowledge of the comparative merits of chickenhood in the different classes.

This leads us to notice the recommendation conveyed in the report furnished us of the late Birmingham meeting, that "old and young poultry should not be shown in the same classes;" and if, as is there suggested, the question as to which will be the best bird at a subsequent day is permitted to influence the judges, our vote should unhesitatingly be given for the summary exclusion of all chickens from the classes assigned to the older fowls. Nothing should be more positive than that the prize-pen should be *that which is best at the actual time of the show*.

But, we imagine, there are very few persons of experience, with fowls of any variety, who, on the eve of a show, where they proposed to exhibit, have not looked with dismay on the tattered plumes and evident ill-condition of many of their older birds at that season of the year, and many a pen would thus have been necessarily unoccupied had not an early cockerel or pullet been at hand to supply the deficiency. A late moulting season, or a prolonged one from unfavourable weather, is constantly productive of these results, and the present popular favourites, Shanghaes and Spanish, are, perhaps, of all others the most subject to this untimely disfigurement. The most hurried glance, indeed, at some of our late exhibitions told this tale most forcibly. While, therefore, we heartily concur with the principle advocated for the separation into distinct classes of the chickens of the year and the older birds, the management of our poultry-yards, must, we fear, be conducted on some more skilful principle than has yet been acted on, if, without a very large flock to select from, creditable specimens, as regards both plumage and other points, will be always forthcoming at that season from among the senior members of our yard. W.

COVENT GARDEN.

WHEN this department was added to the pages of our Journal, and this heading adopted, it was not intended that the subjects treated of should refer exclusively to the great Metropolitan mart; but rather, taking it for our type, we might from it cull observations which apply to every phasis of horticultural commerce and finance. And whilst it is our intention to continue to

furnish, as we have done, a faithful and critical report of what goes on weekly in Covent Garden market, we shall also, as opportunity offers, entertain any subject which has any reference to garden produce. It was in the carrying out of this principle that we commenced the subject of orchard-planting, which has engaged our attention for some weeks past; and the more we think of it, the more we are convinced of the great necessity there is for our suggestions being carried out with as little delay as possible. Scarcely a day passes over our heads but we are experiencing practically, that what we have stated is true, and indeed too true. We have been requested by several country friends to procure, for their enjoyment during this festive season, something in the way of choice fruit as a dessert; and this we have done after much difficulty, but with much greater reluctance, for it is anything but agreeable to have to pay 3s. and 4s. per dozen for *Pears* of very ordinary quality; and that is a low price when compared with some others, which cannot be had under 6s. Such subjects we shall continue to refer to as opportunity offers. But there is another matter which also comes under this department, which has been suggested to us by a correspondent; and we have in our own experience frequently met with cases similar to that of which he complains. As there may be many of our readers similarly situated we shall insert his communication in full.

"Will you allow me to suggest that now and then (say monthly or fortnightly) a list should be given in your paper of the *Flowers, Fruits, and Vegetables*, in season, in order that a numerous class of your readers may not be so completely at the mercy of their servants as at present? For my own part, I know but little about gardening; but paying two men's wages, and by no means stinting the nurseryman's account, I do not like to have excuses in the stead of produce, which I see in the markets can be produced elsewhere. True, some may be of foreign growth; but I fancy if employers like myself knew more about it, their gardeners would make a much better show. If I saw in THE COTTAGE GARDENER that Mushrooms or Brussels sprouts were plentiful, I would take care they should not be scarce with me. But at present, if I am told that those at market come over from Holland, although I may not believe it, what can I say? Gardeners soon find out whether their masters are 'up' to them or not, and act accordingly."

This is written from the suburbs of London, where there is a set of men, falsely called gardeners, continually prowling about—a little time in one situation, and again a short time in another. They never remain long in one place, and they rarely, if ever, entirely leave the locality. They have pot companions and kindred associations, which keep them hovering about as unclean birds hover about carrion; and we very much fear the man of whom our correspondent complains is one of these. Of such, we counsel him to beware. It is such men as these who bring disrepute on the profession, and, indeed, on all professions; and when we entered

on the publication of our market reports for the information and direction of honest men, we also kept in view the check they would exercise over such unprincipled characters as our correspondent refers to.

Last week we gave some account of the appearance of the market during Christmas week. Pretty much of the same aspect still continues to pervade it. VEGETABLES are still very plentiful, the open, mild season contributing to keep everything in a forward state. SAVOYS realized 1s. per dozen, and are of excellent quality. There are some which are not so fine, which were sold at lower prices. GREENS sold freely at 1s. 9d. to 2s. per dozen bunches. CABBAGES, according to quality, made from 9d. to 1s. per dozen. BROCOLI, 6s. per dozen bundles. BRUSSELS SPROUTS were plentiful at from 1s. 6d. to 2s. per half sieve. TURNIPS were also plentiful and good at 1s. 6d. per dozen bunches. ONIONS 2s. 6d. to 3s. per bushel, according to the quality. LEEKS, 2d. per bunch. CARROTS, 3s. to 4s. per dozen bunches. PARSLEY, 2d. per bunch. HORSE RADISH, 1s. 6d. to 2s. 6d. per bundle. These include the leading articles, besides which there were several parcels of forced Sea-kale and Rhubarb.

Among FRUIT we have Apples plentiful, and rather a dull sale; but they still maintain firm prices. Good dessert APPLES cannot be obtained under 8s. and 10s. per bushel; some, however, of the small, which have been sorted out, can be had as low as 5s. The baking sorts are much more plentiful than the dessert, and make from 5s. to 7s. 6d. PEARS are very scarce, and are not to be had in quantity. *Passe Colmars, Ne Plus Meuris, and Chaumontel*, make 2s. 6d. to 3s. per dozen of second-rate quality; but for good specimens they realised 6s. per dozen. GRAPES are very short. *Black Hamburgs* 6s. to 8s. per lb.; *Muscat of Alexandria* 12s. 6d. per lb.

The same profusion of EVERGREENS and FLOWERS continues as we reported last week; and as we did not observe anything remarkable besides what we mentioned in our last, we must refer our readers to our previous report. H.

GOSSIP.

WE know so many of our readers would willingly gratify our coadjutor, *Mr. Beaton*, if they had but the opportunity, that we venture to depart from our usual course, and ask those who are subscribers to the *Wanstead Infant Orphan Asylum*, or who know others who are, to aid him in attaining his object, as detailed in an advertisement to-day. The little orphan for whom he solicits votes is entirely dependent upon him for support.

The *vine mildew* has been so injurious to the Grapes in France, that in the department of Herault, where the country wine sold on an average for forty francs per muid of 700 quarts, it is now selling for 150 francs. The owners of vineyards anticipate that the next vintage will be even more deficient than the last.

Stoves to be devoted to the growth of the *Victoria Regia* are about to be erected in the Botanic Gardens of

Belfast and Glasgow. That at the latter town is the more worthy of notice, because the building-fund has been raised by a penny subscription among the artisans of that city. The *Gardeners' Journal* states, from the report of the directors of the Garden, that by the 13th of December nearly one hundred thousand pence had been thus collected.

We recommend to our readers *Hogg's Edging Tiles for Garden Walks*. They resemble the outer moulding of a picture-frame, and combine the three requisites, neatness, durability, and cheapness. The following is Mr. Hogg's description of the edging, published in the "*Horticultural Society's Journal*," and parties requiring further information may obtain it by writing to Mr. Hogg, 13, Gilston Road, Brompton—

"My first intention was merely to satisfy my own wants; but many friends who saw my edging, and whose opinions in such matters are worthy of consideration, advised me to have it introduced for the general good.

"With this view I have caused some of the tiles to be sent to the Garden of the Horticultural Society, for the opinion of the Society as to their applicability and usefulness.

"Their great recommendations are durability and ornament. They are composed of the same clay and are manufactured at the same works as the patent hollow bricks, and from what I have seen of them, they appear to become harder on exposure to the weather. Cheapness is another great qualification. They can be supplied in any quantity at 10s. 6d. per 100, or about 1½d. each, each tile being one foot in length.

"I would also call the attention of the Society to the mode by which they are secured in their position, although they allow the borders to be cultivated close to them, and any extent of the soil disturbed or removed. The shoe which passes under the walk being covered with four inches of gravel, when that becomes "bound" the tiles are literally immovable, and no wheelbarrow or roller can displace them. They also afford ample drainage for the walks, and under no pretence whatever do they ever harbour slugs. I have had experience of them for nearly twelve months, and I have found them answer all the purposes an edging is intended to supply, and that too at more than one-half less than dwarf box, and nine-tenths less than many other edgings.

"*Note by the Vice-Secretary.*—This kind of edging appears to possess much merit. It is hard, good-looking, a good colour, cheap, and enables the walks to be relieved easily of water. The accompanying figure represents one of the main tiles seen in perspective. It is 4 $\frac{7}{8}$ inches broad, 6 $\frac{3}{8}$ inches deep, and 12 $\frac{1}{2}$ inches long. In forming curves very short lengths of the same kind are employed."

THE following is a list of the *Poultry Shows* of which we are at present aware. We shall be obliged by any of our readers sending us additions to the list, and giving the address of the Secretaries.

CORNWALL (PENZANCE), January 10th, and 11th. (Secs. Rev. W. W. Wingfield, Gulval Vicarage, and E. H. Rodd, Esq.)

DONCASTER, January 21st. (Sec. H. Moore, Esq.)

GREAT METROPOLITAN, January 11th, 12th, 13th, and 14th. (Sec. W. Houghton.)

HONITON, January 12th. (Sec. H. K. Venn.)

REIGATE, February 1st and 2nd. (Sec. J. Richardson, Esq.)

TORQUAY, January 14th and 15th. (Secs. A. Paul, and J. C. Stack.)

THE WINTER DESSERT.

Most of our readers are aware that many of our fruits, although excellent in summer, or even autumn, nevertheless, are not adapted for winter purposes, admitting that they can be procured at that period. Thus, the Queen Pine, which is everybody's favourite from May to October, is almost worthless in the dead of winter; and, indeed, the same may be said of the Providence, the Enville, and various others. To be sure, they are grown—to sell, somebody will say—yes, and to eat; but this does not prove them the most eligible. We are led to offer these remarks from observing in a contemporary paper (*The Gardener's Journal*) a list of fruit obtained from various quarters, showing, in a tolerably clear way, which are the most general favourites for late autumn and winter use; and as the subject seems quite apropos as to the season, we must beg to place it before our fruit-growing readers. One thing may be observed in the way of preface, that the majority of those who have given reports are men of no small repute in the gardening world; we, therefore, refer to their reports with pleasure and with confidence.

The subjects reported on are Pines, Grapes, Pears, Apples, Plums, Raspberries, Currants, Strawberries, Guavas, Medlars, the *Passifloras Edulis* and *Quadrangularis*, and the shell fruits. As many of the readers of this work may not be acquainted with the particular kinds, we will point to such as in our judgment deserve a marked attention.

In PINES the Queen kinds muster about eleven, whilst the *Black Jamaica*, almost always confounded with the *Montserrat*—perhaps the best winter Pine in England—counts seven. Next, we must point to the *New Cayennes*, which bid fair to become, not only popular, but useful: of these we have two of the smooth-leaved, and three of the prickly varieties. The other Pines we at once pass by, as not deserving, in the same degree, the character of winter Pines.

In GRAPES, eleven quote *Hambros*, seven have the *Muscats*, and seven the *St. Peter's*—"a dead heat." There are besides, our new *Black Barbarossa*, about which much fuss has been made, and we are glad to see not in vain, for Mr. Spencer, of Bowood, Wilts, no mean authority, parenthetically observes, "fine, and keep well." Besides these there are several varieties, but as they are not at present much in the market, and as our business is to point to well-known, profitable kinds, we must even pass them by, although some of their names are tempting.

In PEARS, the *Winter Nelis*, *Glout Morceau*, *Duchesse d'Angoulême*, *Beurré Diel*, command a majority; and in APPLES, our old favourite, the *Ribston*, is "head-and-shoulders" above all the rest. The *King of Pippins* seems a great favourite; and the *Downton* and *Blenheim Pippins* come in for a good share of patronage.

In the PLUM way we hear of nothing but the *Coe's Golden Drop*. How is this? where are the *Coe's Late Red*, and the *Imperatrice* section, that were so much spouted-up whilst new? Of course some late *Currants* are to be found, and *Alpine Strawberries*.

We must now beg to comment on these and other fruits adapted for use from the end of November until the end of January, when the question assumes a new phase; others must supply the gap; of which more on another occasion. We will commence with a crowned head—the *Pine-apple*. It is a great pity that the true *Black Jamaica* of the Horticultural Society should be constantly liable to be confounded with the *Montserrat*; but so it is. Even in this country, five out of six call the *Jamaica* the *Montserrat*. Now this should be put a stop to; it points at once to the propriety of referring to some one standard authority, and the great need for the committees of exhibitions so to plan their awards as

that all blundering of this kind be disqualified. It is silly enough, in these bookish days, to mispel names; but to give altogether a false name is decidedly unpardonable by the public. Whatever the *Cayennes* may prove, this has hitherto proved the best winter Pine in cultivation, and peculiarly adapted to the Hamiltonian mode of culture. However, we find that Messrs. Spencer, Tillery, and Turnbull, cultivate the prickly *Cayenne*, and Fleming and Spencer the smooth kind.

With respect to *Grapes*, we are glad to find the new black *Barbarossa* spoken highly of by Mr. Fleming, and grown also by Spencer. The *Trebiana*, grown by Mr. Tillery, is new to us. He calls it an excellent late white; we will write to him to beg information. The black *Morocco* used to be esteemed a good winter Grape, and we are surprised to find it so seldom grown. However, we shall do well to stick close to the *West's St. Peter's*, *Muscat*, and *Hambros*, for the present, for winter use.

We may now point to some excellent winter Pears and Apples; and first, the *Pears*. *Marie Louise*, as a November Pear, it is well-known cannot be excelled; we have them still in use, but they were retarded by mat-shading applied the moment they were anyways ripe. "*Thompson's*" is a capital November fruit, and so is *Fondante d'Automne*, though the latter is somewhat earlier, indeed, may be called an October fruit. *Hacon's Incomparable* good and hardy; *Duchesse d'Angoulême*, too, is both good and a great bearer, in use from the middle of October to the early part of November. *Beurré Diel* is a great bearer, and highly spoken of in the south, but it takes a second rank here (Cheshire) whether on a wall or table trellis. *Napoleon* we have tasted good at times; *Passe Colmar* excellent, and a great bearer, but must have a pretty good wall-aspect in the north; anywhere north of the Humber, a south aspect. The best of all the Pears is, doubtless, the *Nelis d'Hiver*, or Winter Nelis; we have never known it equalled; even the *Marie Louise* cannot reach this invaluable pear. It is, moreover, a great bearer, and may, by good management, be had in use from the middle of November until the beginning of January. This is a most singular pear in regard of habit. We could never imagine from what kinds it could have been raised, the foliage being so different from all other kinds. The wood is peculiarly slender, and the leaves almost lanceolate; more like some fine willow than a pear. It is not unlikely that the old *Crassanne* is the parent on one side. We have grown very fair specimens this summer on an ordinary dwarf standard, as also on a little trellis; but the remarks applied to the *Passe Colmar* may be attached to this: it is better deserving a south wall than any Peach in cultivation, its utility is so great; and we here advise those about to commence its culture to graft it on a strong pear stock, for it seldom becomes luxuriant; and we should be inclined to doubt the Quince. *Beurré bosc* we can do nothing with in the north; a great bearer, and of immense size, but nobody will eat them whilst a *Marie Louise* or a *Nelis* can be had.

One caution, however, is requisite here; in some seasons neither *Marie Louise* nor *Nelis* are to be had, and then these second-rate Pears become useful; for a middling fruit is better than none. It so happens that such Pears as *Capiaumont*, *Beurré Bosc*, *Beurré Diel*, &c., seldom or never miss a crop, they, therefore, may do to fall back on. We may here observe, that the *Glout Morceau*, although generally treated as a wall Pear, fruits here every year as an ordinary standard. We have also a *Beurré d'Aremberg* on a Quince stock, a tree fifteen feet high, and which in bulk covers little more ground than a huge Black Currant bush. This tree is in form an umbrella, and we gathered this autumn nearly six pecks from it; they are amongst our first-class

pears. About eighteen years since, being strongly impressed with the idea that Pears had generally failed on the Quince stock, through ignorance of their peculiar character as to soil, we made a station for this tree, imitating, as near as possible, the soils in which we had known the Quince to flourish—in fact, a rich alluvium. The experiment answered the expectation so fully, that out of some three score trees here, most of which succeed admirably, this is the most profitable; therefore the *Beurré d'Arenberg* and *Glout Morceau* we may cordially recommend to our readers. *Easter Beurré* does not appear to have many patrons; we, however, find it a useful pear, and certainly a great bearer: we never knew it fail. Those who like the spicy flavour of the old *Swan's Egg* or *Muirfowl Egg* will relish this; it has, doubtless, been produced from these old pears on the one side. Why it should be named *Easter Beurré* it really is difficult to say, for we never could eat one after January: perhaps it is so called, in a negative sense, as not being good at Easter! To sum up in the Pear way, there is *Althorpe Crassane*, one of the most capricious things in existence: sometimes the most luscious Pear in the world; sometimes a mere turnip which has lain drying in some scullery for a few weeks. We have proved *Beurré Langelier* (Rivers), and *Doyenné d'Hiver Morceau* (Rivers), new pears; but we dare not recommend them at present. *Ne plus Meuris* is a tidy pear, a good bearer—not good enough for a first-class pear here, yet too good to throw away.

We must now call attention to APPLES; and first, everybody knows the *King of the Pippins*, or, as our "great unknown," who furnishes the Covent Garden reports, affirms to be in reality the "*Golden Winter Pearmain*." Now this is a useful Apple, but the *Williams' Pippin* of the Horticultural Society of London, one of the same class, is far superior, at least so we find it. This *Williams' Pippin* we advise every one of our friends to get; good bearer, good to eat, and a right healthy tree; as a great modern authority has said of a Grape, "one that does not know how to shank;" so say we of this apple: one that does not know how to fail. Well, there is *Hugh's Golden Pippin*, a good new apple; *Adams' Pearmain*; *Margille*, although liable to canker, is a rich apple; *Court of Wick*; *Blenheim Pippin*; and *Ingestrie*, highly recommended, one of Mr. Knight's Golden Pippin seedlings, but never liked here.

There is one thing strikes us as extraordinary in the returns adverted to, and that is the leanness in regard of novelties. It would appear that superior fruit, like superior men, do not spring up every day. In these returns we see the following, which, a very few years back, were said to be valuable accessories to the modern dessert:—*Adams' Pearmain*, good, certainly; but only one advocate, Mr. Tillery; *Court Pendu plat*, too, one patron, Mr. McEwen; again, *Maclean's Favourite*, backed by Mr. Henderson alone. *Cornish Gilliflower* has Mr. Dawson for a friend. *Wyken Pippin*, a name which has figured in every list for the last seven years, has the name of Henderson alone appended to it. There are, indeed, several others which are of recent origin, and which have not yet made their way, although backed by high authorities.

R. ERRINGTON.

BULBS.

(Continued from page 242).

BRUNSVIGIA (BUPHANE) CILIARIS.—This, with *distycha* and *toxicaria*, forms a distinct section of *Brunsvigia*, and they are much more difficult to flower and to keep in good health than *B. Josephinae*, *B. grandiflora*, and *B. multiflora*, the true Candelabra plants of the Cape. This species was found growing in strong clay, along

with species of *Mesembryanthemum*, and a strong yellow rough loam with a little sand suits it best in a pot. Good drainage and small deep pots, in proportion to the bulbs, with the soil pressed close together and to the bulbs, are all necessary points for this plant in particular. The pots called upright 24's, or upright 16's, must be used for most of the imported bulbs of this and of *B. distycha*. If this bulb is received from the Cape in the summer, or at any time after the end of February, without any signs of growth in it, the grand secret is not to pot it until the end of the following August. In the mean time it should lie in the sun, with free air, and be kept as dry as possible, and be turned round and round, and every time the white bugs looked for and destroyed, which come over in myriads with all large bulbs from the Cape. If the bulbs stand half-an-inch from the pot at the widest part it is enough; and after once any of these large bulbs make healthy roots and leaves, they should never be disturbed again until they break the pot with extended growth. After potting, give one good watering from below by means of a saucer, and the moment you see the surface of the soil turning damp remove the saucer, and that watering should last all through September. Early in October the bulb ought to be in leaf; but if it should not come into leaf till Christmas, no heat should be applied, nor any kind of forcing, and from the moment the leaf can be seen, the bulb should have as much air as if it was out-of-doors; and if actual frost is kept from it no cold will affect it during the winter, and very little water will do for it till the middle of February. Then increase the watering by degrees, and if a sunny month, the bulbs may have water every other day until near the end of April, and by the end of May it should be at rest, and receive a *dry* and *hot* rest till the end of August or middle of September, when the flower scape ought to give the first indications of life and motion. The flowers are pinkish, and come in large heads like those of *Agapanthus*; and a strong bulb in Africa will have as many as 230 flowers in one head.

BRUNSVIGIA (AMOCCHARIS) CORANICA. This large bulb must be kept quite dry from October to the end of March; then to be potted in the same kind of soil and in the same way as the last. The natural heat of that season is quite enough, for it is in a greenhouse or cold pit until about Midsummer. An old-established bulb might stand constantly in a saucer of water from the middle of May, but to have no more water than would just cover the bottom of the pot. When the leaves are full grown in June the pot should be plunged to the rim in a brisk bottom-heat of 85°, and a strong current of air allowed day and night. Without this it does not throw up the flower scape; when this appears, and is four or five inches high, bottom-heat should cease, and the constant moisture at the bottom be renewed until the flowers begin to open in the greenhouse. After that give no more water than will keep the leaves fresh until they begin to change colour. If the bulb should not flower, keep it in the bottom-heat until the leaves die down.

BRUNSVIGIA (BUPHANE) DISTYCHA.—This is one of the largest of all the Cape bulbs, and is readily known by its dark skin. It is a darker looking bulb than any from the Cape; but it seldom comes in those boxes the traders make up for speculation, probably because it grows beyond the range of their gathering. It requires exactly the same treatment as *Ciliaris*.

BRUNSVIGIA (AMOCCHARIS) FALCATA.—It does not matter whether we take this or *Coranica* as the species, the other is only a little variation from it. If a very old bulb of one of them were to flower at the same time with a very young bulb of the other, one might find a slight difference in the shades of the flower, but that is all. The misfortune of these bulbs is, that their culti-

vation was so little understood at first that few could flower them; so that one botanist seldom had an opportunity of examining more than one or two species; and each succeeding botanist had a different notion about the points that distinguish one species from another, and the result is, that not the slightest reliance can be placed on all that has been written botanically on Amaryllids from the days of Linnæus.

BRUNSVIGIA GRANDIFLORA.—This is the next largest bulb, and a true *Brunsvigia*, flowering before the leaf in September or October, after resting all the summer, and growing with us during the winter and spring like a Hyacinth. The same treatment we give to our best Hyacinths will just suit it. If it were shut up close in a cold frame for ten days, before the end of January, it would not recover itself that season: it is much more impatient of want of air than *Josephina*. I had a native specimen of the flowers of this bulb gathered within tide-mark, or, at least, very near the sea, in Table Bay; and the naval officer who gathered it was confident that the roots must have been often in salt water. There were forty-two flowers in the umbel, and each flower stalk was a foot long, and probably more before drying. There is not much difference in the flowers of this and of *Josephina*. They are a dull-red colour chiefly; and after all the talk we make about them, they are not very showy or gay, but only curious. *Multiflora* is of a much brighter colour; and that of *Amocaris falcata* is gayer than either of them.

BRUNSVIGIA JOSEPHINÆ.—This is the easiest to flower of them all, and the easiest to keep. A smart frost has no effect on the leaves. I had common pot Geraniums killed, roots and all, within a foot of it in a border, without any bad effects either on its broad, recumbent leaves, or on the neck of the bulb, which was up to the surface. There are two or three varieties of it, unless they arise from the difference in the age of the bulbs. One of them is certainly more streaked with minute dark lines in the flower. Any attempt at forcing this bulb deranges it for twelve months. The pot cannot be too small for it, if the bulb can be got inside of it, and a good depth for the roots; the bulb is just as safe if only one-third in the ground; and it never wants a change till it splits the pot, like a strong *Crinum*. I have seen it with only fifteen flowers on a scape, but generally there are from twenty to thirty, and they spread out candelabra-fashion, quite as much as those of *B. grandiflora*.

BRUNSVIGIA LUCIDA.—This name must be expunged from the genus, the plant it is applied to being a true *Nerine*. It was by a mistake in Dr. Herbert's Appendix that it got into this genus. He, however, made the correction in his *Amaryllidaceæ*. It suffices here, therefore, to say, that it must be kept growing all the winter in a low temperature, and with abundance of air. Strong, friable, yellow loam suits all this race.

BRUNSVIGIA MARGINATA.—This bulb is totally lost to us. It was found by Masson on the west coast on this side of the Cape, and is figured by Jacquin; but as it is supposed to be the only link by which *Amaryllis* can be united to *Nerine*, through *Brunsvigia*, I shall describe it, in the hope that some one journeying from Cape Town to the Orange River may fall in with it. Any one the least acquainted with plants may know it. The leaves are about three inches wide, and four long, when the flower scape appears; and there is a red tinge all round the edges of the leaves, which no other African bulb represents. On squeezing the leaf between the fingers it has a disagreeable smell. The flowers are a little waxy, and not quite scarlet. Any one who could get this bulb and carry it to Sidney, would open a sluice which would drown one-half of our bulb botanists, and would very nearly place the beautiful *Amaryllis* on the same footing which Linnæus gave it.

BRUNSVIGIA MINOR is only a dwarf variety of *Josephina*, if even that.

BRUNSVIGIA MULTIFLORA.—A true *Brunsvigia*, and the best of them, but was mismanaged for more than twenty years, through Mr. Sweet saying that it was a stove plant, in the first number of "The Gardener's Magazine." He said it was like *Hæmanthus multiflorus*, but they were then (1826) in such confusion that we hardly knew which he meant. But these *multifloras*, however, will live out-of-doors with a very slight protection, and Sweet never could have written that from his own practice, for heat soon spoils them. It requires exactly the same treatment as *B. Josephina*, *B. grandiflora*, *B. ciliaris*, and is the best of them for crossing with *Belladonna* on one side, or with *Valotta* and *Nerine venusta* on the other. A triple cross from the three last would make the finest genus of all that we know of in Amaryllids; but we want the connecting link (*B. marginata*) before *Nerine* will breed with any of them.

BRUNSVIGIA RADULA.—A small bulb, also from the west coast on this side the Cape, of which we know nothing beyond Jacquin's figure. Like *B. marginata*, it comes near to *Nerine*. Thus it would seem that the intermediate link which is wanting to connect *Amaryllis* to *Nerine* inhabits a zone on the north-west limits of the genus in Africa, where no botanical collector visited since Masson.

BRUNSVIGIA STRIATA.—This is either a variety of *B. multiflora*, with the flowers more streaked, or a nonentity.

BRUNSVIGIA (BUPHANE) TOXICARIA.—This, like all *Buphanes*, has the flowers much crowded in the head. They are smaller and more erect than in the true *Brunsvigia*, but the same kind of culture and soil will suit them. A strong, friable, yellow loam, pressed hard, and with good drainage, is best. One accustomed to Cape bulbs could pick out *B. toxicaria* at first sight, from the light brown colour, and the long shape of the bulb. An upright hyacinth-pot is sufficiently long for a full-grown bulb of it. The least touch, or cut, to any part of the living substance will cause it to bleed a thick creamy substance, which is said to be poisonous, and which, I know, will stain linen badly.

The best of all these is *Brunsvigia multiflora* and *Amocaris falcata*, and then *B. grandiflora*, and the fourth, *B. Josephina*; and except it be for experiments, these four are all that are worth growing of the very large Cape bulbs. *B. ciliaris*, if well grown, would look well, or rather interesting, from the great quantity of flowers in one head. None of them are worth crossing in England, except to prove how far the limits of *Amaryllis* extend, because seedling bulbs of them take half a lifetime to flower; but in Australia, New Zealand, the south of China, Natal, or Valparaiso, and such places of similar climate, they are, of all other bulbs, the most promising.

Under *Cyrtanthus*, which is another section of *Amaryllis*, I shall point out the cause why crosses in many of these sections have failed in Australia. After getting through all the bulbs, I shall point out classes of them which will do to grow together in different ways. Meantime, two corrections have reached me already, for which I am very thankful. I said that none of the *Collanias* were introduced; they are *Alstromeria*-looking plants, with a growth exactly like the common *Fritillaria* of our own meadows, an upright rigid stalk, the top of which bends over, from which a cluster of flowers hangs down. *Collania dulcis*, flowered at Spofforth, and was figured in "The Botanical Register" in 1842. I said that the error about *pelegrina* was continued by every one save Dr. Herbert; and am told that Dr. Lindley writes *peregrina* since the mistake was discovered. I am too old now to take offence at anything in this way, and would wish to be criticised severely in

all I advance on these bulbs, to see how far we can make THE COTTAGE GARDENER a standard authority for them; any facts, however trifling they may appear to others, will assist me materially.

D. BEATON.

HARD-WOODED GREENHOUSE PLANTS.

WESTRINGIA DAMPIERII.—The chapter to-day will be chiefly devoted to the inquiries of correspondents. Both the generic and specific name of the above plant are commemorative. We are indebted to New Holland and New South Wales for the group. The present species is a low evergreen shrub, producing small whitish Rosemary-like flowers in autumn and the beginning of winter. It is easily propagated by short stubby cuttings, inserted in sand, under a bell-glass, in a shady frame in April, or even, in similar circumstances, under a hand-light in a shady border in June. Sandy fibry loam, enriched with a little rotten leaf mould, or very decomposed, dried cow-dung, will grow it admirably. It will want a good supply of water in summer, and, of course, less in winter. Little pruning will be requisite, unless what is wanted to keep the plant in shape, and the required size, and that had best be effected in spring. A suitable position for the plant would be an open place out-of-doors from the middle of May to the middle of October, and a cool place in a comfortable greenhouse in winter.

Though, to meet inquiries, I have stated the above, I must add, that where either show or great interest are objects, and the room not very great, I should never think of recommending the above to an amateur's notice. There is nothing very striking in the whole genus, but the most so are those with bluish flowers, such as *Rubiaefolia*, *triphylla*, and the older *rosmarinifolia*.

The last, and most of the rest, will stand a sharpish frost, if kept dry in winter at the base of, and trained against a wall. I had noticed this genus, and the allied one of *Prostanthera*, as being well worthy of a trial against a conservative wall. I recollect, many years ago, seeing *P. lasianthos* against the wall in Chiswick Gardens. From some hints, it would be seen, I intended saying my say on this interesting subject, but my friend, Mr. Appleby, has first got possession of the field, and it could not be in better hands. I think, however, to avoid confusion, and to prevent mistakes in these progressing days, a few new names and terms will have to be given and defined. A conservative wall, in its original meaning, was merely a common wall, furnished with a coping, capable of being widened in winter, so as to throw off wet, and prevent the radiation of heat; and against this plants were tried as to their comparative hardiness; or, it was ultimately covered with creepers, twiners, and such plants as would bear to be grown with one side, without impairing their beauty. The next idea was to have for such a wall a short sloping or hipped roof, with upright glass in front, enclosing a space of some six feet in width, so as to admit of a path inside; thus permitting of the enjoyment and the examination of the plants in all weathers. Now, though air could be admitted to such a wall at pleasure, and though keen frost would find its way easily through the glass in winter, if neither double glass nor other covering were resorted to, yet, as even then, from the closeness of the sashes, the atmosphere within would be still, and consequently the stems of the plants would neither be so ruptured nor robbed of their juices as in a frosty wind, on a conservative wall, the same term should not be used, but a new one should be coined, such as "glass-cased wall." Again, the term conservative is still more inappropriate when applied to such narrow structures when heated. What is there to distinguish them but their narrowness, from any common conserva-

tory? What plant is there that will flourish in a greenhouse or conservatory, that will not also succeed in such a narrow house? The one at Chatsworth is a noble structure, and it will be still more grand when extended to the north, so as to join the mansion. But such a structure, when heated, would be more properly called a "conservatory wall," instead of a conservative one. In fact, such a wall might be a plant-stove wall, or a peach-house wall, or a vinery wall, a ripening wall, or a forcing wall, according to the purpose for which it is employed. Mr. Fleming has put up great lengths of such structures at Trentham, marked alike by simplicity, economy, and efficiency, for a destined object. He finds that he can have a trellis nearly half-way up the front without shading the back wall. In some of these structures he intends, by sun-heat alone, to accelerate and mature; while in others, he intends to force and obtain early fruit. Now, these facts will show there is a necessity for a new class of terms. Besides, it is necessary to notice, that these heated "conservatory" walls will be very apt to lose in attractive power when their novelty is gone, just because, except in the case of twiners, creepers, and one-sided plants, there will be the want of the "natural" as respects other plants placed against it. A plant that grows as a bush, or a low tree, may be cultivated against a wall, and look beautiful too; but then the looker-on can form no idea of its natural habit. Had I the chance of enclosing such a wall, I would prefer a width of ten or twelve feet to the half of that space; and then, in addition to the clothing of the back wall, I could have nice bushy specimens in the border in front. "Well, but that would just be a conservatory." Just so; and a heated glass-enclosed conservative wall is nothing else. The wider house would merely require more space, more glass for the roof, and more heating power, than the smaller one; the latter nearly, but not quite, in proportion to the greater surface of glass on the roof, as the greater body of enclosed air would prevent the place being so suddenly cooled. I have alluded to the matter in passing, and I think that some definite terms are not unworthy the consideration of Mr. Appleby, and other coadjutors.

EUTAXIA MYRTIFOLIA.—This beautiful New Holland shrub blooms in the autumn, winter, and spring months. Its small orange flowers are produced in great abundance along the young shoots. The following will be found a concise and yet full outline of the treatment it requires in pots.

Propagation.—Choose short, stubby shoots, getting firm at their base, in April or May; cut clean across at a bud, and insert in silver sand, over an inch of sandy peat, the lower part of the pot being filled with drainage. When watered, place a bell-glass over them, and set them in a frame, or pit, where they can be kept close, but without artificial heat. They will soon strike, and then should be potted off in sandy peat, and placed again in a similar place, preventing flagging by shading, and dustings from the syringe. When taken with the pots, stop the growth, by nipping off the points of the shoots, to make them bushy.

Selecting Plants.—Choose a low-growing bushy fellow, although it should not be the fourth of the size of a leggy one.

Soil.—For the first few shifts, when the plants are small, use chiefly sandy peat, and a little broken pots and rubbly charcoal. By the time you get them into four-inch pots use a little sweet fibry loam, and let the loam be in equal proportions to the peat when the plant will fill a six or eight-inch pot, using even then abundant clean drainage, and charcoal, broken pots, and silver sand, to keep the soil open, packing it firmly about the roots.

Watering.—This will be required liberally in summer, less in autumn, and a fair portion in winter, especially

if in bloom. Syringings over-head in spring and summer will be of great importance, and tend to keep red spider and scale at a distance.

Pruning.—This plant, when young, requires frequent stopping; when grown to a flowering state it should be pruned back when the blooming period is over. The greater number of equal-sized young shoots made in summer, and the better they are matured in autumn, the more abundantly will you be supplied with bloom.

Position and Temperature.—When pruned, the plant should be placed in a pot where it can be kept close and warm, or the same advantages given it in the greenhouse. Little water should be given at the roots until fresh shoots have broken, but the stems and the atmosphere must be kept moist by the syringe. As the shoots increase in length, more air must be given, gradually at first, until the tops of the plant are fully exposed in August and September. It will be advisable to house, or shelter, in October; and in winter, if coming into bloom, the temperature at night should not be below 45°. If not in bloom, 5° less will suit it better than a dry heat from fires. In fine, sunny forenoons in winter a dash from the syringe will do it good. In the south of the island this plant has been found to stand against a conservative wall; north of London I have little doubt but it would answer against a glass-cased one, more especially if it was so managed as to flower about the months of April or October. There are other two species—*E. pungens*, very similar in habit, having likewise small orange pea-blossoms, sometimes called *Dillwynia pungens* and *Baxterii*, having yellow flowers, and more robust in habit. These latter may be treated in a similar manner, but they almost constantly produce their blossoms in early spring and summer.

EUCHILUS OBCORDATUS.—This is another pea-blossomed plant, with small yellow-flowers, produced chiefly towards the points of short young shoots. The yellow in the bloom is contrasted with a purple keel. The principal characteristic in the plant is its blunt, curious, reversed heart-shaped leaves, and its upright mode of growth. In the main points of culture, that recommended for *Eutaxia* may be followed. I will merely notice the difference in some little points. It blooms chiefly in early summer. The cuttings may consist of the points of shoots, if side-shoots cannot be got; and after being inserted, in May or June, for a few weeks, they will be benefited by a little bottom-heat. I have never heard of it doing much good, unless as a greenhouse pot-plant. It requires even then considerable attention. The soil should be three parts peat and one loam, well drained, and well opened with pieces of broken brick and charcoal, and a fair portion of silver sand. Stagnant moisture is its ruin. It should not be dashed with heavy rains even in summer. A pit is, therefore, a better place for it than a position in the open air. The night temperature in winter should not be much below 45°. Great care must be taken then not to sour or sodden the soil. In dull weather it will seldom want a visit from the water-pail. Pruning should take place when the flowering is over; but unless it be required to keep the plant small, the pruning should not be severe. It is more safe to grow on a young plant than to lop an old one.

R. FISH.

THE AURICULA.

THIS most elegant and highly-esteemed spring flower has not progressed so much as most other florists' flowers, either in improved varieties, or in public favour: that is, the number of growers have not increased. The public, indeed, admire the flowers as much, or more, than ever, when they see them exhibited; but there is not that eagerness about cultivating the Auricula as there is about Pelargoniums, Cinerarias, Carnations, and some

other flowers: and why is this? Confessedly the Auricula is behind none in beauty of form, elegance of colour, and neatness of habit, besides being sweetly perfumed. The causes, no doubt, are a kind of fear that they are difficult to grow, slow to increase, easily lost, and rather high in price, especially the very best kinds. Now all these reasons are, I think, unfounded, or, at least, not more applicable to this deservedly-favourite flower than to many other florists' flowers. Carnations, Picotees, Pansies, Ranunculuses, and Tulips, are equally difficult to keep, some of them as slow to increase, and the best quite as high in price. I consider it rather a stigma upon amateur florists that they neglect this spring-blooming, beautiful flower. It is true, though it is a native of the Alps of Europe, it will not bear our cold, foggy, changeable, damp winters, for it requires the steady, dry Alpine atmosphere of its native dwelling; but our persevering florists overcome greater difficulties in culture than this of managing the Auricula, so as to imitate the dry, pure air, and covering of snow, in the Alpine regions. I have been requested, by a new correspondent, to give a list of the best Auriculas, with a few brief hints on their culture, and this request has drawn from me the above preliminary remarks, and I trust many of the readers of THE COTTAGE GARDENER will find the following useful; and some that have not hitherto turned their attention to this charming flower, may be induced to try to cultivate, at first, a small collection; and by way of encouraging such to make the attempt, I assure them they may procure four-and-twenty very good old kinds for 36s.—no very heart-breaking outlay. The only other article that is expensive is a two-light box to grow them in through the winter and through the blooming-season in spring; and this two-light frame, after that season is over, may be used either for cucumbers, or for propagating various kinds of flowers. The glass is cheap, and wood is not very dear, so that this frame will not be excessively expensive, and a new beginner, for a very few pounds, may make a fair start in Auricula culture; and if success attends his efforts, I will venture to prophecy he will be perfectly satisfied with his small outlay—small in comparison to beginning to cultivate a decent bed of Carnations or Tulips.

To make my instructions easy to remember and understand, I will divide Auricula culture into, 1st, Soil; 2nd, Summer treatment; 3rd, Winter treatment; 4th, Propagation; 5th, Properties of a good Auricula; and lastly, a list of the best in their various classes.

1st. *Soil*, or rather compost. Simple soils, such as heavy loam, light loam, bog, or peat, would not grow the Auricula to that perfection which is required in order to produce strong blooms finely formed and highly coloured. This every florist of any experience is aware of, and, therefore, he combines three or more kinds, and this mixture is properly enough called *a compost*. For the Auricula, I am no advocate for a rich, stimulating compost, yet I am quite sure it requires one, in a certain degree, enriched with something that may be described as mildly encouraging, in order to produce strong growth, and, consequently, fine bloom. Such stimulating manures as night-soil, blood, sugar-baker's scum, fowl's dung, &c., that some writers recommend, require, in order to temper their highly-stimulating powers, so long a time exposing to the air, with frequent turnings, that when it is safe to use them, the greater part of their enriching powers or qualities have evaporated, and the residue is not much better than common earth, so that all this long preparation is time and expense thrown away. The compost I have used with the greatest success is much more simple, more easily procured, and is sooner ready to use. It consists of loam procured from an upland pasture, or, in some districts, from a pasture near to the banks of a river; of this, the

top spit, not more than four or five inches thick, is the best. This should be carted home, laid up in a long, rounded heap, and turned over (chopping the turf into pieces) three or four times during a year. In that time it will be fit for use. This kind of loam may generally be procured from some nurseryman mellowed down ready, if the amateur cannot procure it, or wait till it is prepared. The next article is some well-decomposed manure, such, for instance, as hotbed-manure a year old. Then a portion of vegetable mould, made from decayed leaves of trees, and, lastly, some sand, either that called silver, or some from a river-bed finely sifted. The proportions are—four-parts loam, one-part manure, one-part leaf mould, and about one-tenth part of sand. The whole to be thoroughly mixed at the time of using, without sifting, excepting the river sand. While the mixing is going on, any stones, roots of weeds, wire-worms, &c., should be carefully picked out and thrown away. Use the compost in a state neither wet nor dry. This compost, used in a proper state, and of a right age, will grow *Auriculas* strong, and bloom them satisfactorily, all the other points of culture duly and properly attended to. These points must be the subject of my next paper.

T. APPLEBY.

(To be continued.)

CONSERVATIVE WALLS.

(Continued from page 225.)

TRUSTING my former remarks on these walls have at least set our readers thinking on the subject—and, let me hope, some few will not only think but actually try the experiment of erecting one and putting it to the uses I have hinted at—I now proceed to answer the question—Should this wall be heated? and this query involves the very natural one—By what means?

In our uncertain climate we have some winters that are so mild that numbers of half-hardy plants pass through that season with very little injury against a wall, even without heat; but then, every seven or ten years, we have one of our old-fashioned winters, such as that never-to-be-forgotten one of 1837-8, in which the thermometer sinks down to zero! and then the constitution of our plants is tried to the utmost. I need not remind our readers, that in that season the common Laurels, the Laurustinus, Sweet Bays, and many others so-called hardy shrubs or trees, were cut down to the earth, and in some cases completely killed. Now, as no one can foretell, or be certain, that such another season will not happen again, I answer the query by saying, emphatically,—most certainly, Yes. Let this conservative wall be provided with the means to be heated. If the season proves mild there will be no necessity to light the fire; but should it be severe, or if there is any likelihood of its being so on any night, or successive nights and days, then the gardener is provided against its injurious effects, and will feel perfectly secure and easy in his mind, that he has the power to preserve his cherished plants, let what weather will come. The owner, too, will feel glad, in the event of a severe frost, that he has been induced to heat his walls, and by that means preserved his rare and beautiful plants that have, perhaps, for years delighted himself and his friends with their beauty and aromatic perfumes.

The walls, then, whether for fruit or plants, having been determined to be built, and, furthermore, to be heated, the query next to be answered is, By what means? It has been mentioned that the walls at Osmaston Manor (see page 183) are heated by hot-water pipes, and that, I can aver from ocular demonstration, most effectually; and, inasmuch as those walls heated with hot-water answer admirably, it follows that the

best means of heating a conservative or any other kind of garden wall, not even excepting glass ones, is by hot-water pipes. These points being settled, the next query in rotation is—Should it be covered with glass? The answer to this query requires some consideration. Though glass is much cheaper than it used to be, still, to cover a wall, perhaps a hundred feet long, the cost will be, as a Yankee would say, “tarnation considerable;” and besides, the mode of doing it might be still more expensive. As it is, a wall for ornamental purposes, the covering of glass, to be in character, should be ornamental also. It would not be at all advisable to put up the glass cover in the rough manner of Mr. River's orchard house merely for the sake of economy, or, in other words, for the saving of a few pounds to cover it at the least possible expense. No, if it is determined to clothe it with glass, let it be done handsomely, something in the style of the often-referred-to one at Chatsworth, which is a handsome object, independently of the fine specimens of rare plants it contains. The principal considerations in favour of covering this wall with glass is the more certain protection to the plants, and the comfort of walking under it in wet or stormy weather. It might then be connected with the sitting rooms of the house, and would be a most agreeable promenade in all kinds of weather. All this I must leave to the consideration of the owner. The covering with glass is not absolutely necessary, but it is absolutely advisable to determine, previously to commencing building, all these particulars. 1st. Whether to build it at all. 2ndly. If it is to be built, to have the wall hollow. 3rdly. To heat it with a boiler and hot-water pipes; (these pipes should be placed near the bottom, inside the wall, and the inside should be contrived so that the heat will have access quite to the top; the pipes are placed near the bottom for the convenience of circulation, the heat being sure to rise, from the well-known fact that heat always rises, provided no solid body interrupts it.) 4thly. To cover it with glass carried out so far from the wall that there will be space for a walk at such a distance from the plants that they can be easily seen and examined. Supposing it is determined to make a thorough good job of it, and do it well, handsomely, and effectually, so as to answer the purpose and be a comfort and pleasant recreation, then procure an estimate from a respectable builder, with proper specifications, and let it be put up during the spring and summer months, in time to be planted before the cold weather commences.

T. APPLEBY.

(To be continued.)

THE CLOSE OF THE YEAR.

HAVING arrived at the close of a year, the autumn of which has been one of extraordinary wetness, a great deal of out-door work has, in many instances, been delayed; and we fear that much that has been done, has been accomplished under circumstances which very much impair its utility. The heavy and almost continuous rain has so soddened the ground, that all operations must have so consolidated it, as to render it almost impervious to the influence of the atmosphere. Now, bad as this is, I am far from thinking that a piece of ground, hardened by being trod upon, or otherwise pressed down, is the worst condition that it can be in at this untoward season, as it must be apparent, the more solid it becomes, the less water it is likely to hold, as is easily seen by turning-up a spadeful. Now, though at certain times rain water imparts a fertility to soils (apart from the refreshing effects it has on the plants growing there), still, when administered in too great a quantity, its utility is like that of

many other valuable things, hurtful when given in excess.

The continuous rains wash out of the ground those soluble matters which it is most in want of; the essence of dung, and other enriching manures, being so frequently soaked in water, necessarily part with their juices, which, being carried below the reach of vegetation, are lost to the ground. This being so often repeated, has left the ground that abounded in rich animal or vegetable manures robbed very extensively of some of its most important component parts, without the soil deriving any commensurate advantage in return. Now, it is easy to perceive, that grounds throwing off the rain, or allowing it rapidly to subside, are less likely to be injured by the extraordinary fall of rain than those retentive and tenacious soils which, having once become saturated, are very tardy in parting with it; on such soils, it is not too much to say, that if they cannot be relieved by judicious draining, that a hard-pressed surface, in a wet autumn, is better than a loose, fresh-dug one; the latter only allowing the soil to hold more water, without that water being enticed away by any of those means which draining is especially provided for; while its remaining so long unchanged in contact with soil not requiring it, a sourness arises, which requires some considerable exposure to the atmosphere, &c., to remove. This state of things is much aggravated when any one is so indiscreet as to dig or till ground at the time it is so saturated. It is then compressed mechanically into a condition more resembling mortar than anything else; in this state, a long period of favourable weather and treatment is necessary to bring it round again, and it does not always happen that this description of weather follows after a wet season. The long-continued drying winds of last spring were very beneficial that way; but who amongst the many that have undertaken to prophesy the forthcoming season, have said anything but "serious forebodings of severe frosts and snows," following each other with that destructive tendency which made the season of 1837-38 so memorable in a horticultural point of view. That the weather of the next two months is destined to be like that veritable season, is not my purpose here to prognosticate, but that it may exceed the severities of the last three winters is very probable, while vegetation is certainly not in the most hardy condition to resist it.

The setting-in of the wet season before the growth of many deciduous trees and shrubs had been brought to a close retarded, and at last only imperfectly ripened them; tender and late-growing evergreens were in the same condition; while herbaceous growth has been stopped by incessant wet, rather than cold; the number of frosty mornings having been few and unimportant; while drying winds have been less plentiful; so that, taking altogether, we may conclude that many things are in a bad condition to withstand the rigours of a winter of more than ordinary severity. It therefore becomes the careful cultivator's duty to see what protection can be given them, or rather what can be done to enable them to stand frost and snow with less harm to themselves. *Brocoli* that are fit to cut suffer much if exposed to frost; it is better, therefore, to take up all such, and hang them up in some cool place away from drying winds or withering fires; observe, they must not be much stripped of their leaves, and the stem must be left pretty long as well. The hardier kinds, which it is not prudent to lift, may be partly laid down, which is done thus: beginning at the west side of a piece of *Brocoli*, dig a small spit out close to the stem of each plant; then bend them down all that way which is pointing west, the earth from the bottom of the next row of plants may be laid on the last, and the second one bended over the same as the first, and so on

until the whole be done, when they will present a mass of plants, all lying on their sides, and pointing westwards. This direction I think is best, and likewise better than lifting them entirely and removing them to another place, because the loss the roots sustain by the practice here recommended is not so much as when the whole plant is taken up; in fact, beyond the fractures of a few fibres, on the side it is bent from, the injury that way is unimportant. The prostrate position presents a greater number of folds of leaves as covering to the heart than is shown by the ordinary upright position, while the attempts of the plant to regain that posture is equally useful in producing a more effective covering to the central, or more tender part of it. *Endive*, that has been partly blanched, may be taken up with balls and carried into some dry cool shed, and there placed with its roots in sand. A sufficient stock of all *Roots* which remain in the ground during winter might be taken up and similarly treated; this includes *Celery*, *Horseradish*, *Jerusalem Artichokes*, *Parsnips*, *Turnips*, and, in fact, all other roots which are left in the ground in ordinary seasons; a few of each for present consumption may, as I have said, be housed as above, care being taken to prevent their withering. *Protection* must also be given to *Peas* that were sown in November, which the absence of cold weather has brought forward to a greater degree than usual. We have found barley-chaff laid along the rows, and secured there by drawing a little earth to it, better than anything else that we have tried; coal-ashes are also good that way. *Beans* may be treated the same, while *Spinach* can only be protected by a covering of mats or other matter of that kind; thatched hurdles are very good, too, and for crops growing in beds as this and *Lettuce*, they act very well by leaning against each other in the centre, forming a "span-roof" of no mean capacity. By this kind of shelter, large and forward *Lettuce* plants may be saved, while the younger ones, being hardier, stand the winter without such covering. It is almost useless to talk of covering-up frames, &c., because this is so universal a job as to be known to every one. The *pumps*, *water-pipes*, and other contrivances for supplying that necessary article must also be duly protected, if not already seen to, and all other means adopted that can render things more secure, such as the well-covering-up of *potato-heaps* and other stores; and in fact, all those *et ceteras* which alone constitute good management must be seen after before that severe weather sets in which weather-prophets tell us is in store for us still.

J. ROBSON.

ACCOUNT OF A PROVINCIAL HORTICULTURAL MEETING IN SCOTLAND.

IN comparing the present with the past state of horticulture throughout different districts of Great Britain, one is forcibly struck with the advances which have been made within only a brief period of time; and there can be little doubt that much of the progress is imputable to the exertions of Horticultural Societies. By means of these useful institutions, a spirit of emulation has been evoked in localities remote from the general intercourse of the world, and among classes to whom a love of plants was hitherto an unknown pleasure. No small amount of ordinary procedure in society may be said to be a result of fashion, more than of deliberate principle; and taking advantage of this conspicuous tendency, horticultural societies have, wherever established, created a certain fashion in the taste for plant-culture, and thereby fixed and given currency to feelings that might otherwise have languished, and been of no practical avail. The fashion being led by parties for whose opinions and habits there is considerable respect, others in their various degrees have followed, till at length the most humble and least excitable have been stirred into activity. Having attained this desirable point, it is astonishing how

the newly-created flower-culturer expands in his notions, and becomes possessed with a love of plants. He, as it were, has come into a new life. The face of nature, it may be, once blank in his eyes, is now clothed in beauty; and existence has charms which were not formerly dreamed of.

It is obvious that this love of plants has two important consequences. In the first place, it need not be insisted on that gardening—the treatment of plants according to the enlightened rules of science and art—is of the highest economic value, and that by all proper means it could be carried to its utmost limits. But, independently of this practical view of the subject, there is something in gardening, even on the humblest scale, that commends itself to our favour. And here we would draw an illustration from a contemporary periodical. “It has been very properly observed,” says a writer in *Chambers's Journal*, “that a love of gardening, on however small a scale—be it only the tending of a pet flower-pot—has in it something that exhilarates and improves. One seldom hears of gardeners misconducting themselves; and we venture to go a step further, and say, that no person whatever, who once imbibes a taste for pansies and hollyhocks, and thinks much of cultivating dahlias and anemones, is likely to be an indifferent member of society. It would not be difficult to demonstrate, that the promotion of a taste for flowers and plants generally, leads to an elevation of taste in other things; and it is remarkable how little is required to excite a love of horticultural pursuits, even in situations supposed to deaden the higher class of emotions. A story is told of a whole village in the Highlands being stimulated to enter on a course of improvement, from the simple circumstance of a lady one day expressing her admiration of a single marigold which grew in the neglected garden of one of the cottagers. ‘Is it possible,’ thought the proprietor of this little flower, ‘that anything I have in my poor garden is worthy of the approval of a lady? If so, I will endeavour to make things better—I will try my hand at a few more flowers.’ Thus reasoning, the cottager began to occupy himself in his garden; neighbours followed his example; a spirit of rivalry was begun; and, lo! in a short time the whole village, interior and exterior, assumed quite an improved aspect—cleanly doorways, walls decorated with flowers, and a general advance in all matters of taste. Now, this anecdote, which rests on good authority, affords a pretty fair specimen of what may be done by a little judiciously-administered approbation, acting upon a spirit of honourable competition.”

So much may be said in the way of general observation. Our more special object in the present article is, to describe the rise and progress of a Horticultural Society in one of the rural districts of Scotland; and at the same time, to offer such hints on the method of getting up institutions of this kind, as may prove useful to those who are desirous of establishing them. A short account of the society in question, appeared in the journal above quoted; and a more extended notice for practical purposes being, to all appearance, called for, we trust that that which is now to be submitted, will realise all reasonable wishes on the subject.

The institution to which we allude, is named the Peeblesshire Horticultural Society. It was established in 1850, and consists of a body of individuals of three different classes—professional gardeners, amateurs, and cottagers; each member of the two former classes pays a fee of 2s. 6d. per annum; and cottagers, whose yearly rent does not exceed £5, pay a fee of 1s. per annum. The members appoint, from their own body, a president, vice-president, treasurer, and secretary. These officials are, of course, honorary; the secretary, though having no little correspondence and general management to attend to, acts gratuitously, and for the mere sake of advancing the cause of horticultural improvement. At present, the president is Anthony Nichol, Esq., of Kerfield, a gentleman of landed property in the neighbourhood; the vice president is Arthur Burnett, Esq., resident sheriff of the county; and the secretary is Mr. John Stirling, one of the magistrates of Peebles, which is the place of meeting and centre of operations of the society. Besides these functionaries, there is a committee of management. The society, we observe, graces its prospectus with a list of patrons: these are certain noblemen and gentlemen in the neighbourhood, whose names and influence are

believed to be of consequence in giving the thing a respectable character in public estimation. Some of, perhaps all, the patrons contribute a small annual donation in money to the institution; but this feature, beyond what may be required at starting, we do not commend. It is most desirable that all such institutions should be self-supporting, and not rely on charitable doles. The true and safe plan of operation, is to form a fund from the regular annual fees of membership, and from sums gathered for admission to the public exhibitions. In these latter respects, the Peeblesshire Society is on a healthy footing. We observe, from the published accounts of the society, from September, 1851, to September, 1852, that the amount of subscription-fees of gardeners, amateurs, and cottagers was £13 2s.; of donations, £9 1s. 6d.; and of tickets of admission for two exhibitions, £24 11s. 7d. Latterly, the amount of tickets of admission has been about £15 each time. The amount of prizes at each exhibition is about £14. All the money drawn is deposited in a bank, and from this fund the disbursements are made. A respectable individual is appointed to audit the accounts. Thus, the whole financial part of the proceedings is conducted in a methodic and business-like manner. The present number of members on the books is 147; and all who are members may compete. No one can compete or receive a prize, who is not a member. There may possibly be parties in the district who are not members, yet who could shew better flowers than those of regular members; but they would not be taken into account in the matter of distributing prizes. And the reason for this is evident. The whole scope of the institution is to excite emulation; and this is best done by each person having an absolute contributory interest in the concern; for when a man's own money is at stake, his perceptions are wonderfully sharpened—he sees to proper administration of funds; and, at the very least, makes an effort to get back, in the shape of a prize, what he paid out in the form of a fee.

In competing for prizes, members are divided, as above, into three classes—namely, 1. Professional gardeners; 2. Amateurs; and 3. Cottagers. Promiscuous competition is not allowed; nor would it be fair. Each class competes within itself. The first-mentioned class consists of the gardeners employed by the landed proprietors in the neighbourhood; and who, besides their professional skill, may be presumed to have means at their disposal for bringing forward plants. The second class consists of persons above the rank of cottagers; they are supposed to attend to their own gardens, with perhaps occasional assistance. The third, or cottager class, are, as stated, persons who occupy houses at a rent of not above £5 per annum, and whose means are consequently slender; and it is mainly for the improvement of this class that the society is instituted. Members of any class must be resident within the county; and no vegetable or flower can be brought forward for competition unless it has been a certain length of time in possession of the exhibitor. Besides the articles raised for competition, certain other articles are admitted to the shows, merely to exhibit as curiosities, or to evince what can be done in the district. Some plants are sent solely for the purpose of embellishing the exhibition.

It was considered desirable to have two exhibitions in the year, one in July, the other in September—the latter embracing the larger kinds of fruits. Since the commencement in 1850, these exhibitions have gone on increasing in the variety of the articles shown, and the number of visitors. The exhibitions took place in the largest room of the principal inn. At the exhibition in September 1851, two imperfections in the arrangements were forced into notice. The first was, that the judges were too few in number for the work to be gone through, and they accordingly did not finish their duty of allotting the prizes till an hour-and-a-half after the time appointed for opening the doors. This, with the great crowding which ensued, made it apparent that more judges were required, and that there ought to be a much more spacious place for exhibition. Both these remedies have been applied. The judges for each show are now four in number, and are, as formerly, professional gardeners [from a distance, who have no knowledge of the parties exhibiting. All things for exhibition require to be lodged by half-past 10 o'clock forenoon of the day of competition, and the exhibition opens at 2 P.M. All kitchen

vegetables require to be cleaned, and free of extraneous leaves, &c. The principal improvement in the arrangements has consisted in having the exhibition in a temporary canvass tent, of large and commodious dimensions. We invite attention to the manner in which this tent was pro-

cured, also to its size and appearance; and for the better understanding of its character, we append two sketches, drawn by Mr. John Bathgate, a gentleman filling the office of procurator-fiscal for Peebles-shire, and a warm encourager of all social improvements.

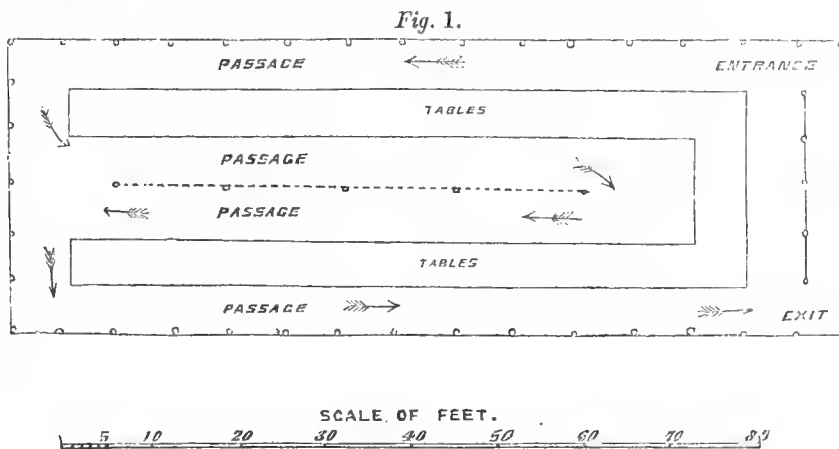

Fig. 2.

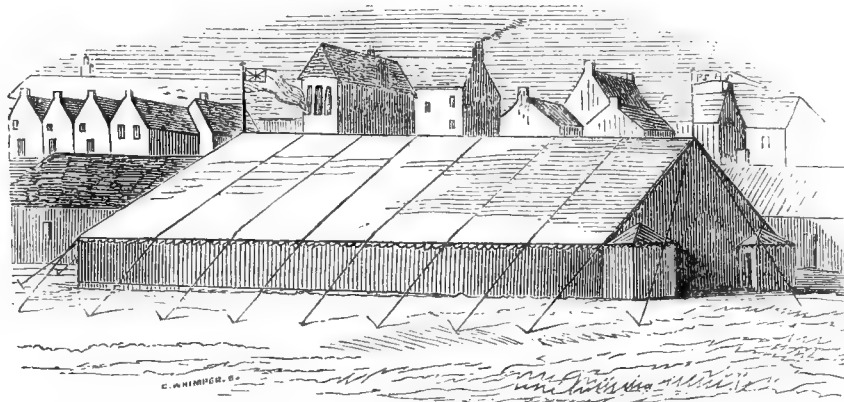

Figure 1. represents a ground-plan of the tent, with two long tables, on which the articles are laid for exhibition. These tables are of rough deal, covered with webs of calico, so as to have a clean and neat appearance. The entrance is by a kind of porch at the north-east corner; thence, as indicated by arrows, the visitors walk up the side of one table, and down the other side; then up the nearest side of the second table, and down the other side of it, to the place of exit, which is a similar porch at the south-east corner. Visitors thus proceed in a slow and continuous stream in one direction, without break or confusion. Figure 2 is a representation of the tent exteriorly, and in perspective, looking from the south-east, with the houses of the town in the background. It will be observed that the tent is a pavilion in form, being of a length about three times its breadth, with a sloping roof on its two sides. The following are the exact dimensions:—Length of the tent, 91 feet; breadth of ditto, 33 feet; height of roof at centre, 24 feet; side of span of roof, 23 feet; height of walls from the ground, 8 feet. The two porches are exterior projections. The length of the tables is 73 feet; the breadth of each table is 5½ feet; and the breadth of the passage is 5½ feet.

The substance of the tent is strong canvas, impervious to rain; but so transparent, that there is abundance of light without the aid of windows. The erection is supported on a framework of wood, held together by screw bolts. Besides the side, there are centre, posts. The distance between the side posts is 6½ feet; the distance between the centre posts is 13 feet. All the wood-work has a neat and slender appearance, and is painted. The total expense of this truly commodious erection, including painting, was about £80; this amount was raised by subscription in the neighbourhood, and kept separate from the ordinary funds of the society. It may be useful to mention, that the manufacturers of the tent were Messrs. R. and D. Ferguson, Sail-makers, Dundee. It was made by them to order, and sent

ready to be put up. The wooden framework was constructed by Mr. Dickson, a carpenter in Peebles; part of it was composed of timber presented by Sir Adam Hay, Baronet; and this somewhat lessened the general expense. When erected, the pavilion has a handsome and rather gay appearance, with the Union Jack flying at one end, and the flag of the Society displayed at the other. It was placed in the Town Green, in front of the school-house; and at about a hundred yards from the Tweed.

Even with the vastly extended space in this conveniently disposed tent, there would still undoubtedly be overcrowding, but for an arrangement to be mentioned. This consists in establishing three classes of entrance fees—for the first hour, one shilling; second hour, sixpence; and the third hour, threepence. Tickets are issued corresponding to this plan, which has proved eminently successful, and has given much satisfaction. All are accommodated, and all are pleased. It should be added, that the ticket admits only once. Should a visitor go out, he cannot return without making a fresh payment. A few police-officers attend to prevent disorder; and a brass band from a neighbouring village plays outside during the exhibition.

The committee of management, which meets once a month, determines on the objects of competition and prizes to be allotted. Prospectuses containing all requisite lists and particulars are issued and distributed gratuitously, from six to nine months previous to the exhibitions. In these prospectuses there appear not only the lists of prizes of the society, but lists of special prizes offered by private individuals. Such prizes are usually of larger amount than those of the society, and in many instances apply to only one or two parishes. We may be allowed to quote two or three from the list of 1853:—

“Anne Lady Hay, for the best kept Cottage Door, and ornamented with flowers, in the Burgh of Peebles, including Tweedbridge-end, 7s.—for the second best, 5s. There must be at least three competitors for this prize.

"Lady Carnichael, for the neatest kept Cottage, in the parish of Skirling, 10s.—for the second best, 7s.—for the third best, 3s.

"W. S. Orr, Esq., Amen Corner, London, for the neatest kept Cottage, interior and exterior, with front ornamented with flowers, also best kept Garden, in the parishes of Peebles and Innerleithen, a copy of the Illustrated Shakspeare; value, One Guinea.

"W. S. Orr, Esq., to the occupant of the neatest kept Gate Lodge, interior and exterior, with front ornamented with flowers, and well kept Garden, in the county of Peebles, 10s.

"Lady Montgomery, for the finest and purest Honey, fit for the table, for Cottagers only, 10s.

"Lady Montgomery, for the prettiest Flower-Basket, made by the exhibitor, open to the whole Society, at July Exhibition, 5s.

"W. Chambers, Esq., of Glenormiston, for the most exact and best kept set of Meteorological Tables, for the year 1853, beginning with 1st of January, and ending with 31st of December, in the parishes of Peebles and Innerleithen; open to all classes of members, £1 1s. *Copies of blank forms for entering daily observations will be given by the Secretary; and intending competitors must hand in their names to him on or before the 25th of December, 1852. This prize will be awarded at the July Exhibition, 1854.

"Archibald Craig, Esq., South Bridge, Edinburgh, for the best and neatest kept Cottage Door, and ornamented with flowers, in the parish of Eddlestone, 10s.; for the second best, 7s. 6d.; for the third best, 5s.; for the fourth best, 2s. 6d. There must be at least eight competitors. It is distinctly understood that no occupant of gentlemen's lodges can compete for this prize."

It may be added, that there are likewise a few sweepstakes; the competition in such cases being a kind of wager between two neighbours as to the production of certain flowers or vegetables.

Such may be accepted as a familiar account of the Peebles-shire Horticultural Society, which, considering the character of the district, has succeeded in its praise-worthy aims beyond all expectation. The sphere of operation is a county of small size, composed principally of the valley of the Tweed, in the upper and more pastoral region of that classic stream. The district is environed with brown hills, which, though favourable to the production of mutton and grouse, are not altogether friendly to horticultural pursuits. Yet, under certain disadvantages with regard to climate, placed aloof from the stimulating movements of an energetic and busy age, and depending entirely on its own resources, this small county, through the agency of a few active-minded individuals, has started forward in the race of horticultural improvement, and its exhibitions, as regards out-door productions, are pronounced by competent authorities to equal any thing of the kind in the most highly-favoured districts of England. On a future occasion, we hope to be able to make widely known through these pages the names of those competitors whose peculiar success seems deserving of approbation.

With so much to be said in commendation, it would be strange if the proceedings of the society in question did not suggest reflections of a somewhat less pleasing character. It deserves notice, that here, as elsewhere, discussions have arisen respecting matters which, for anything that can be foreseen, already bear within them the elements of dissolution. We are the more inclined to speak unreservedly on this branch of the subject, from a desire to offer a candid and friendly warning before it be too late, not only to the members of the present institution, but to others, in whatever quarter of the country they may be placed.

The first thing to which we would thus admonitorily refer, is the system of preparing plants, fruits, or other articles for competition, at an expense of time, trouble, and money, infinitely beyond the actual value of the thing, and to all appearance for the glory of obtaining a place in the list of successful competitors. Emulation, carried to this undue length, is evidently an evil. The struggle may be said to be in some respects a competition of purse against purse, instead of skill against skill, and as such, is adverse to every sound principle of economics. It can surely serve no good purpose, to produce half-a-dozen monster leeks at a

cost of a load of valuable manure, or a few bunches of grapes at an outlay of £5 for extra fuel, exclusive of trouble and time beyond all reasonable allowance. A procedure of this kind is not horticulture at all: it is a vulgar forcing of nature beyond her legitimate bounds, and, if not checked, can terminate only in general disgust and disaster. Among amateurs and cottagers who employ their own means in these supernatural forcings, the practice is less objectionable than among gentlemen's gardeners; for, in the latter case, the means belong to another. No doubt, the costly experiments of these horticulturists are in many instances effected with the sanction of their employer; but this scarcely saves the practice from condemnation. It should be the pride and duty of gardeners to conduct their operations on an economical scale, and work more by professional knowledge than the powers of excessive and costly forcing. One thing is certain, that no body of gentlemen will long continue to support any institution that causes an habitual and unreasonable outlay. It may be gratifying for a season to see their servants carrying off prizes of half-crowns; but when employers calculate that for every half-crown so gained by their gardener, they themselves are called on to expend a pound for manure, or for some special apparatus, their enthusiasm for horticulture may justly be expected to decline, and finally expire, leaving nothing but disappointment behind.

The question as to how far any class of competitors should go in the matter of forcing, is not susceptible of a distinct solution. Common sense ought to regulate the employment of means, keeping a certain end in view. Some persons have objected to the use of glass, but glass, we apprehend, falls within a proper system of culture; and, indeed, all expedients that are dictated by science and practical art, are not only permissible, but commendable. We are quite aware that on the subject of means to ends, the society has a delicate part to perform. Yet, it is the duty of a society to adopt some suitable method of placing horticultural experiment on a footing that will prove permanent and beneficial. It can never be supposed that an institution is to stand by unconcernedly, and see itself destroyed. Something it may do by way of recommendation or address, and all else failing, it may call for a declaration as to the cost of production from competitors. A hint on this subject is enough.

Another unfortunate feature of societies of this kind is the jealousy which is introduced into a neighbourhood. Numbers, of course, care not who overlook their operations, and watch the progress and quality of their plants and flowers. Others are more sensitive. They are afraid to have their gardens intruded upon, while the grand competition cabbage, or the wonderful half-dozen pet anemones, are coming to maturity. Now, this is a very undesirable terror. We like to entertain kindly ideas of gardening and gardeners of every grade, and feel that a spirit of exclusiveness is quite at variance with all that is commendable in art. The gentlest possible remonstrance on this, as on the foregoing point, is, it may be hoped, sufficient.

With these observations, we would beg to draw our account of a provincial horticultural society in Scotland to a conclusion. The institution, we are glad to learn, has already made a visible impression on the taste of the district. On the highway between Edinburgh and Peebles, stands the small village of Eddlestone, and here the doorways of the cottagers were for ages in a most untidy condition. Now, through the efficacy of small prizes distributed by the horticultural society, the cottages have assumed quite a different appearance. Stagnant pools and dung-heaps have vanished from the scene, and plots of garden with roses and honeysuckles rise pleasingly into view. In other quarters, similar advances are perceptible. Bee-husbandry has made a marked progress, and we can confidently say, that the finest honey which could be produced was shewn at Peebles last September exhibition. Nor are social habits left untouched. Leisure hours, which formerly were spent in the public-house, are now devoted to horticulture. The best powers of the mind, once lying dormant, have been stimulated into activity; and with a prudent regard of means to ends, we anticipate that the society to which we have taken the liberty to draw attention, will yet achieve much higher results.—W. CHAMBERS.

COCHINS, DORKINGS, AND SPANISH.

I mentioned, in a former communication upon this subject, that I was by no means inclined to think that the Cochins were the "enormous" eaters which "Gallus" and his friends asserted them to be, and my opinion has, I see, been shared in by several of your more recent correspondents. It is obvious that this is a question upon which a tolerably satisfactory conclusion may be arrived at, and that without much trouble.

It is important, however, first to determine what the question in dispute really is. If, as "Gallus" now contends, it be whether fowls averaging, say, seven pounds each, do, or do not, consume more than fowls of another breed averaging four pounds or five pounds each, what is the use of the controversy at all? But if the question to be decided be, as I and others have always contended, and as is obviously the reason of the thing, which is the most profitable breed of fowls to keep, the solution depends upon which possesses most advantages and exhibits fewest defects. One important advantage undoubtedly would be, that a particular breed should consume less food than another, having regard to the quantity of food, or rather, perhaps, to the value of the food which it should itself return to them. In this calculation size would be an essential ingredient. If a farmer, for instance, has two breeds of pigs, and one of them will attain thirty stones in weight, and the other only twenty, can he not afford to give the former more food than the latter? Unless the bacon be very deficient in quality, it is manifest that he can.

But if the abstract position for which "Gallus" contends be tenable—viz., that size has nothing to do with the matter—the question of utility is gone, and the Bantam (or, in the case I last put, the little pig) beats all the other breeds, simply because, being smaller, it consumes less food.

From these considerations it is obvious that the true question is, as I have stated, which gives the best return for the outlay, and, in this enquiry, that size is a principal ingredient. And if a few impartial experiments be honestly made the question can be solved with little difficulty. I, therefore, beg to give you, and, through you, to your readers, the result of one such trial, explaining first how it was made, in the hope that others will make similar attempts to give us the benefit of their experience.

I have no Dorkings; but, as I have before stated, I keep Cochins and Spanish. Their roosts are equally good in all respects, and are situate at opposite ends of the same plantation, into which they both run, but at such a distance that they never mix with each other. Neither has any advantage over the other that I am aware of. There are twenty-nine Cochins, and twenty-three Spanish, and to the latter I added three common fowls (bought for killing) to make the numbers more uniform. The proportions of young and old were alike, and in each lot were three cocks. I feed with whole barley, and with meal; the latter of three sorts—barley, bean-meal, and pollard, or sharps. They have the soft food twice a-day, in cast-iron troughs, as much as they can eat, and if they leave any it is carefully gathered up. The barley, in hoppers, they have to run to when, and as often as they please.

I thought I could not make a fairer experiment than this, but after being absent for three days, I found that two small Turkey poults (weighing together 17 lbs.), which had before been fed with the Spanish, had not been removed, according to my orders. I therefore determined to let them remain during the rest of the week, and to my surprise, I found at the end of seven days that the two lots had just consumed the same quantity, each having eaten 24 lbs. of meal and 30 lbs. of barley.

I now removed the Turkeys, and the death of a Spanish cock reduced the number of Spanish to twenty-five. During the second seven days, the twenty-five Spanish ate 15 lbs. of meal and 24 lbs. of Barley, and the twenty-nine Cochins, 24 lbs. of meal and 30 lbs. of barley.

This, in the latter week, gives an average of 25 ozs. for each Spanish fowl, and 30 ozs. for each Cochin, or a proportion of five to six. But the Spanish lot weighed together 111 lbs., averaging only 4 lbs. 7 ozs., or 71 ozs. each; and the Cochins weighed together 193 lbs., or 6 lbs. 10 ozs., or 106 ozs., each being two to three within 1 oz.

I am by no means desirous that any one should consider such a question settled by a single experiment, but I am not aware that a fairer one than this (for the accuracy of which I pledge my honour) could be made, as both the corn and meal were taken from the same sacks. I shall, however, be obliged, for one, to any of your correspondents who will make similar trials, and favour the poultry-keeping world with the results. I am still open to conviction; but, as at present advised, I am of opinion that the public favours bestowed, as it has unequivocally been of late, upon the Cochins, has gone in the right direction, and that, for all useful purposes, they are the best breed of fowls yet introduced into this country.

I took the liberty, in a former paper, to say that I anticipated that Mr. Sturgeon's sale would afford a strong proof of the general verdict being in their favour. I was favoured with a marked catalogue of that sale, and I subjoin a statement of the average prices realised. It is only necessary to a proper understanding of this paper, to remind the reader that the stock sold at the sale (except the few lots designated as "sundries") was the produce of one or other of these cocks, named respectively, Sam, Patriarch, and Jerry. The result of the sale was as follows:—

Sire.	Cockerels of 1852.	Sold for	Average of Cockerels	Pullets of 1852.	Sold for	Average of Pullets.	Average of both Cockerels and Pullets.
		£ s. d.	£ s. d.		£ s. d.	£ s. d.	£ s. d.
Sam	21	64 5 0	3 1 2	36	143 13 0	3 19 2	3 10 5
Patriarch	23	73 7 6	3 3 9	30	107 12 6	3 11 9	3 7 9
Jerry	23	76 5 6	3 6 4	21	82 11 0	3 18 7	3 12 5
	67	213 18 0	3 3 8	87	333 16 6	3 16 8	

	No.	Sold for	Average as above.	
		£ s. d.	£ s. d.	
Cockerels	67	213 18 0	3 3 8	
Pullets	87	333 16 6	3 16 8	
Sundries	154	547 14 6	3 9 8	Average of Chickens of 1852.
	18	64 17 0	3 12 0	
	172	612 11 6	3 11 2	Average of the whole Sale.

Can I be wrong in concluding, from the sale by public auction of 172 birds to 62 different buyers, at an average rate of £3 11s. 2d. each, that the verdict of the public is in favour of

COCHIN.

P.S. I have forgotten to mention that from the Cochins I had, on an average, eight eggs per day, but from the Spanish only four eggs per week.

FEEDING BEES.—A CAUTION.

ON examining, yesterday (Dec. 14), one of my best hives of bees, I was surprised to find that they had only a few ounces of honey left. This hive swarmed on the 17th of May, and unfortunately threw a maiden-swarm on the 1st of July. This, no doubt, weakened them considerably, but it plainly shows what a wretched honey-season it must have been. These bees, which seemed so very active and strong, could not collect, since the 1st of July, sufficient food to keep them until Christmas.

This extraordinary mild weather will cause a great consumption of honey, and bee-keepers will do well to look sharply after their stocks.

The thermometer has ranged each day, for the last fortnight, from 48° to 55° in the open air, and in a northern aspect at mid-day, a week ago, the ivy near my house was crowded by bees. Probably the immense glut of wet weather had retarded the blossoms, as I have seldom noticed them on the ivy after the middle of November.

The bees alluded to above were the best I have in my garden, as I thought them, previously to yesterday, and certain of going through the winter without feeding. I calculated that they had from 15 lbs. to 16 lbs. of honey, from their great activity during the months of June, July, and August.

I am much indebted to Mr. Payne for many useful hints, and I think he will bear me out this time in my caution, although most likely it may come too late for many unfortunate stocks.

H. W. NEWMAN, *New House, Stroud.*

POULTRY SHOWS.

WE have been favoured with the following note from one of the committee of *The Great Metropolitan Show*. We are glad of its removal, not only because it is now separated from all connection with a tavern, but because it will be much easier of access, and the poultry will be more comfortably lodged; at the same time, we more than regret that the committee persevere in what they know is wrong, by keeping the birds in the pens for so many days.

"It is quite true *The Great Metropolitan Exhibition* is postponed, and the place of exhibition changed to the Baker-street Bazaar, in consequence of the proprietor of the Oval having notice from the solicitor to the Duchy of Cornwall, that no exhibitions of any kind would be allowed on his ground. The committee were, therefore, taken quite by surprise, and you may imagine their chagrin and annoyance at such information, when a beautiful and most expensive building was all but finished. The committee, therefore, immediately waited upon the spirited proprietor of the Baker-street Bazaar, who immediately acquiesced to their terms and application, and we congratulate the public and exhibitors in having secured a more central, more convenient, and more agreeable *locale*; and we are pleased to add, but two of our exhibitors are inconvenienced by the change. The entries close on the 4th of January; the specimens will be received on Friday and Saturday, the 7th and 8th of January; the birds will be judged on Monday the 10th, and the Exhibition open to the public on Tuesday the 11th, Wednesday the 12th, Thursday the 13th, and Friday the 14th; the same days as at Birmingham.

"We have upwards of 1,000 entries, not 1,600, as erroneously stated by a penny-a-liner, who must have mistaken an 0 for a 6."

We are indebted to Mr. J. J. Nolan, the well-known poultry-fancier of Dublin, for the following report:—

"*The Dublin Amateur Poultry Society* had their first show in the spacious round room of the Rotunda, under the patronage of our Vice-Queen, the excellent Countess of Eglinton, who inspected each pen minutely, and proved herself a scientific connoisseur in her selection of some of the finest specimens, which subsequently, and deservedly, obtained the first prizes in each of their classes. A lot of Black Polish, in pen 118, took her Excellency's particular attention. The Embden Geese, with other lots, she commanded to be forwarded to the Vice-Royal Lodge, Phoenix Park.

"The arrangements of the room were judicious, much after the manner of the English Exhibitions, and in the evening it was lighted with gas, and formed an excellent promenade, but the music in an adjoining room was a total failure. This was the first attempt here of having a Poultry Show secured from the inclemency of the weather, and was found most agreeable to the visitors, as well as to the birds. What Dublin poultry-fancier does not recollect "the pelting of the pitiless storm," when the lofty elms in the Dublin Society's yard were levelled to the earth, and the poultry pens performed their evolutions through the lawn! We hope to see all future Poultry Shows, as in the present case, comfortably provided for.

"Lady Domville added to the Exhibition a splendid collection of Water-fowl of great rarity and beauty, in which was the Cereopsis and Bar-headed Geese, with other rare varieties, which would be an acquisition to any Zoological Collection.

"The catalogue, though not long, being of only 211 lots, consisted of, perhaps, as good specimens as any Great Britain can boast of. Several lots changed hands at high prices. There were but few inferior birds. The Pigeons were select and in good feather.

"I perceive we have a new candidate for poultry fame, in the person of a Miss H. Gardiner, who seems to have spared neither pains nor expense in procuring the best specimens of the most approved varieties, and as the prize list shows, her stock was so varied and excellent, they were a real attraction and acquisition to the Society. If report speaks truth, she is determined to promote among her tenants the best procurable fowl, to be distributed to them as one of the industrial resources of the country, and to

add to their comfort. I am proud to make a record of the feelings of such a lady proprietress, and hope it may be speedily followed by our Irish nobility and gentry; and while on the subject, have to regret that some of this lady's birds, procured at considerable cost, to meet the wordings of the amateur prospectus, should be, by either neglect or design, improperly classified, or entirely omitted; and her Aylesbury Ducks, said to be the best in the room, called Labrador! How the managers could mistake the White Aylesbury for the Black Labrador, is of difficult explanation.

"Our judges, unfortunately, are the relatives or friends of the exhibitors, and what Irish judge is so immaculate as not to feel an erroneous prejudice in favour of his friend, particularly when they walk out with printed catalogues in their hands, in which is set forth the names and addresses of the exhibitor; at the same time, I am satisfied, from Sir Edward Borough's high standing and good taste, he does not feel complimented at being awarded a premium for lot 102, which, undoubtedly, should have been announced *no merit*. I would advise, as at the English shows, the judges to be brought from a distance. I am glad that the error of awarding a premium to Mr. Dombain for three chickens, in lot 93, instead of four, has been withdrawn. If such errors be permitted it will be the certain dissolution of the Society; and being a true fancier, and the oldest and first amateur in Ireland, I should regret it of all things. I therefore beg their strict attention to their own rules.

"Now, as to the selection of their officers. I should recommend its being done by a majority of their members, and not by self-appointments. They are more likely to appoint men of intellect, and not persons who have made so many errors in their prospectus, their catalogues, and their premium-lists.

"While on the subject of poultry, it may not be out of place here to remark a new nomenclature adopted at the Birmingham Show. The birds usually known through England as *Bolton Grays*, *Bolton Bays*, *Dutch-every-day-layers*, *Pencilled Dutch Fowl*, *Chittiprats*, &c., are denominated *Pencilled Hamburgs*; and the birds known and exhibited in England at the poultry clubs, denominated *Spangled Pheasant Fowl*, from their markings approaching to the brown Pheasant, each are called in the Birmingham list, *Golden-spangled Hamburgs*. Now, what they are called, appears to me of little consequence, so as it is one general name known and understood by all; but when it varies from what has been known and established for the last century, it cannot but cause confusion; it would, therefore, be well if the principal poultry amateurs would communicate with each other on the subject, and adopt one general nomenclature."

The Judges in Poultry were—The Hon. Captain Arbuthnot, Thomas Rutherford, and Isaac D'Olier, jun., Esqrs.

In Pigeons—A. H. Darley and W. Mason, Esqrs., whose adjudications gave general satisfaction.

The following are the awards of the Judges:

SPANISH.

- Section 1. (Birds of two-years-old and upwards).—No merit.
Section 2. (Birds of 1851).—John North, Esq., Clarinda-terrace, Kingstown.
Section 3. (Chickens).—George Perrin, Esq., Bullock, Dalkey.

DORKING.

- Section 1. (Birds of two-years-old and upwards).—Lieutenant-Colonel Hill, Oatlands, Castleknock.
Section 2.—Mrs. Gresham, Bellegrave, Clontarf.

DORKINGS (WHITE).

Honourable C. H. Lindsay, Island House, Island-bridge.

MALAY.

- Section 1.—Mrs. Franklin, Cottager, Cabra.
Section 2. (Chickens of 1852).—Mrs. Gresham, Bellegrave, Clontarf.

COCHIN-CHINA.

- Section 1. (Birds of 1851).—Mrs. Gresham, Bellegrave, Clontarf.
Section 2. (Chickens of 1852).—Mr. William Ledwich, Mary Villa, Ball's-bridge.

DUTCH OR BOLTON GREYS.

- Section 1. (Birds of two-years-old and upwards).—Lieutenant-Colonel Hill, Oatlands, Castleknock.
Section 3. (Chickens).—Lieutenant-Colonel Hill.

GOLDEN HAMBURGH.

- Section 1.—No merit.
Section 2. (Chickens).—Mrs. Cane, St. Wolstan's, Celbridge.

SILVER HAMBURGH.

Section 1. (Birds of two-years-old and upwards).—Richard P. Williams, Esq., Drumcondra Castle.
 Section 2. (Birds of 1851).—Sir Edward Borough, Bart., Coolock.
 Section 3. (Chickens).—Richard P. Williams, Esq., Drumcondra Castle.

GAME FOWL.

Section 1. (Birds of two-years-old and upwards).—William Madden, jun., Esq., James's-street West.
 Section 3. (Chickens).—Charles Watkin Williams, Esq., Richmond.

BANTAMS (SEBRIGHT).

Section 1.—Miss H. Gardiner, Reigh's-buildings, Clontarf.
 Section 2.—Miss Louisa Cane, St. Wolstan's, Celbridge.

POLISH.

Miss H. Gardiner, Reigh's-buildings, Clontarf.
 Norfolk Turkeys. (Best Cock and Hen).—Mrs. Booker, The Parsonage, Killuran. P. J. Kearney, Milltown House, Clonmillan.

POULTS OF 1852—AMERICAN TURKEYS.

Section 1.—Miss H. Gardiner, Reigh's-buildings.

DUCKS.

AYLESBURY. (Best Drake and two Ducks).—Mrs. Warburton, Kill, county Kildare.

DUCKLINGS OF 1852.—Richard Chaloner, Kingsfort, Moynalty.

ROVEN: BIRDS OF 1851.—Richard P. Williams, Esq., Drumcondra Castle.

DUCKLINGS.—Richard P. Williams, Esq.

GEESE.

Miss Gardiner, Reigh's-buildings.

GOSLINGS.

Rev. Thomas Adderley Stopford, Clongill Rectory, Navan.

PIGEONS.

CARRIERS (Black).—Prize. Mr. A. Le Clerc, Philipsburgh-avenue. (White and Dun).—Mr. Dobbyn, D'Olier-street. Recommended.

POUTERS (Blue).—Mr. P. Jones, Amien-street. Recommended.

RUNTS.—Mr. Le Clerc. Recommended.

TURBETS.—Mr. Le Clerc. Recommended.

BARBS.—Mr. Dobbyn. Recommended.

JACOBINS.—Mr. Le Clerc. Prize.

TUMBLERS (Bald-pated).—Prize. Mr. Richard Wildridge, Lower Mount-street.

TUMBLERS (Almond).—Prize. Mr. Dobbyn, D'Olier-street.

TRUMPETERS.—Mr. Le Clerc, Philipsburgh-avenue. Recommended.

RABBITS.

Mr. Le Clerc.

For the following particulars relative to the late *Birmingham Poultry Show*, we are indebted to the *Midland Counties Herald*, and, therefore, all the statements may be accepted as perfectly correct.

"With regard to the attendance, we have to add that it was very large, notwithstanding the unfavourable weather, and that the receipts exceeded those of any former occasion. The numbers of visitors, exclusive of subscribers, were as follow:—Tuesday, 1,705; Wednesday, 9,326; Thursday, 12,280; Friday, 6,728; making an estimated total of more than 37,000. The money taken at the doors amounted to £1,840, and the sums received for the sale of catalogues to £279 4s. 6d. Among the visitors were the pupils of the Deaf and Dumb Institution, who were admitted gratuitously on Friday morning, and who appeared highly delighted with all they saw, but more particularly with the Poultry Department. To the information relative to the sales of Poultry, contained in the *Herald* of Thursday last, we have to add that they reached to £1,636 15s. 6d. in the four days during which the Exhibition remained open. One object of these shows is to afford facilities to persons who wish to purchase such stock as they may require; and all contributors are required to affix a price to their specimens; but where no intention of selling exists, parties may, and, as is well-known, frequently do, name a sum which is prohibitory, or intended to be so. Sometimes, however, such calculations prove to be erroneous. The pen (294) of Cochin-Chinas, the property of Mr. James Cattell, of this town, which carried off the first prize in Class 12, found a purchaser at £50; and as a proof of the early maturity of the breed, as well as the excellence of the stock from which they sprung, it may be proper to state that the three pullets, hatched on the 20th of April, weighed, when sent to the Exhibition, 9½lbs., 9lbs., and 8½lbs. respectively. Amateurs may also be interested in knowing that for the buff cock exhibited by the same gentleman, contained in the pen which obtained the second prize in Class 11, the sum of twenty-five guineas was offered by a very eminent dealer, and declined. This is the same bird which is figured in the 'Illustrations of

Domestic Poultry,' recently published, and for which a similar price was offered at the Yorkshire Poultry Exhibition, held at Halifax, at the commencement of the present year, where he received the premium for the best male bird of any variety in the yard. We may further state that one very eminent cultivator of the Cochin-Chinas, fearful the price of fifty guineas might not preserve to her the possession of her birds, which were very admirable ones, bought them in, paying the usual commission of five per cent. Other sales took place at very liberal prizes. For a pen (272) containing a cock and pullets in Class 12, exhibited by Mr. Thomas Roscoe, of Prescott, thirty guineas were paid; for another pen, (272,) the property of Dr. Gwynne, of Sandbach, £30; for another, (419,) belonging to Mr. Punchard, in Class 15, £25; for another (452) of White Cochins, belonging to Mrs. Herbert, of Powick, twenty guineas; for a pen of Dorkings, (148,) fifteen guineas; for a pen (475) of the same variety, shown by Mr. Y. R. Graham, of Yardley, twelve guineas; for a pen of Black Polish, (823,) shown by Mr. Edward Hewitt, of Sparkbrook, twelve guineas; and for a pen (902) of White Polish, from W. G. Vivian, Esq., of Singleton, Glamorganshire, twelve guineas. A pen of Toulouse geese, exhibited by Mr. John Taylor, jun., of Cressy House, Shepherd's Bush, London, sold for fifteen guineas; numerous other pens of poultry, of various kinds, being taken at £12, £10 10s., £10, and other smaller sums."

AN AMERICAN GARDEN.

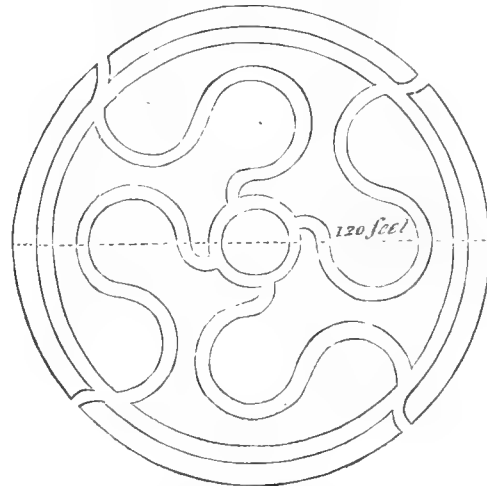

THE accompanying plan is a garden expressly for the cultivation of what are commonly denominated American plants. They are beautiful objects as planted in the shrubbery, but, to be seen to perfection, they must have a piece of ground expressly for themselves, where they can be arranged according to their respective heights, and contrasted in colour. The principal advantages arising from this plan are—that it is very compact; that it is quite the fashion; and, lastly, that it is likely to remain so without change.

It matters but little what the aspect of the garden is, provided it is placed on a gentle declivity, so as to admit of being properly drained. Having chosen the situation, the next thing will be to clear the surface of turf, or what else may be upon it; then, after marking out the beds, to have the natural soil taken out to the depth of two feet, remembering to let the bottom slope gently towards the centre, where the drains will be placed. On this I lay particular stress, for without good drainage, in all places, and under all circumstances, the richest soil will very soon become sour and sterile, and the healthiest plants will soon turn yellow, and linger out a miserable existence, to be succeeded by others equally unfortunate. Common drain tiles do very well, provided they rest on soles, without which, I believe, they are of very short service.

Soil.—As there is a mixture of plants, so there must, necessarily, be a mixture of soil; good turfy loam, not cut too deep, one-part, sand one-part, and fibry peat (not bog) two-parts. These, if chopped up and well mixed together, will meet the wants of all the plants. Take advantage of a

sharp frost to wheel in the soil, which ought to be emptied off planks, remembering to fill the beds six inches higher than the surrounding ground so as to allow for subsiding.

Plants.—These will consist of Rhododendrons, Azaleas, Kalmias, Andromedas, Ledums, Gaultherias, Rhodoras, Vacciniums, Ericas, Epigeas, Menziesias, Daphnes, Empetrums, Fabianas, &c. These form the heads of the various families, but the individual members had better be selected by the planter when in bloom.

Planting.—The principal things to regulate doing this are colour, distance, and ultimate height. First of all, let the colours be so arranged that each plant forms a contrast to its neighbour; and to do this effectually it ought to be done on paper first, so that one may have time to give it an hour or two's consideration. By so doing the work will be gone about systematically, and not with that bungling which is sure to follow an arrangement the mere impulse of the moment. Sufficient distance from plant to plant is very seldom given. We can see this every-day in our plant-houses, wall-trees, flower-garden, &c. By giving one plant the space generally allotted to two the result will be far more satisfactory. Ultimate height ought to be kept in mind, so as to have the tallest plants in the middle.

Walks.—If good gravel is to be had nothing will beat that for walks in this garden; but if that is of an indifferent quality, then let them be made of asphalt or concrete, and edged with stone, slate, or neat paving-bricks.

After-treatment.—The plants will require to be supplied with water for the first summer or two after planting, and mulching will be of great service to them in long-continued drought. Digging amongst them is a practice which ought never to be tolerated; for by so doing all the surface-roots (and they are in all cases the best) are cut off, which sends those left down to the bottom in search of food, which is generally of an indifferent quality; hence, disease which is so often met with.—J. RUST.

POULTRY DISEASES.

WHITE COMB IN SHANGHAES.

A CORRESPONDENT writes as follows:—"Some months ago I wrote to you for information and advice about a disease that has appeared amongst some Cochinchina fowl, and which seemed to have been introduced by a cock purchased of Mr. Punchard. After that, other complaints seem to have been made to you about the same disease. A name was given to it, and a remedy pointed out, viz., to anoint the bird with oil and turmeric. That cure seemed to answer, though not entirely, and is apparently of no use after a certain stage of the disease. As I observe that one or two able remarks have been made through your publication, on the cure of disease of poultry, I am induced to note fully my observations on the disease in question, with a view to ascertain what it is, and the remedy.

"The disease first appears on the comb, which appears white and crisp, it gradually extends down the neck, and the feathers fall off. Old birds and chickens seem equally liable to it. It seems like a sort of scurf, which gradually extends all over the body. The bird seems apparently unaffected in health; it eats voraciously, but on examination it will be found poor and thin, as if the food furnished not its proper nourishment. After a while this scurf appears thick about it, apparently in a moist state; afterwards the feathers, when the bird is let out in the morning, seem to be in a matted state, just like the feathers of a drowned bird; on examination this will be found to be a sort of grease; during the day the grease evaporates, and the feathers become apparently dry; at this stage the bird begins to show signs of weakness, it afterwards refuses its food and dies.

"My full-grown birds all quickly recovered the disease, but not so the chickens. Mr. Punchard's cock had to be destroyed. I do not understand the nature of the disease, nor its cure, but it has often occurred to me, whether feeding birds with grey peas had anything to do with it. I understand Mr. Punchard gives his some occasionally, but unless accompanied with salt or something else, it seems to me that such a food must have a bad effect on the blood.—K."

In making a few remarks on the above, I must beg to be

understood as offering them as suggestions only, having had no opportunity of seeing the *white comb*.

I regard many of the diseases to which Poultry are subject as arising from high feeding and stimulating food. Peas and other leguminous seeds, as beans, tares, &c., contain a very large proportion of a substance which in its chemical and nutritive properties closely resembles animal food, the effect of their use in large quantity, or if long continued, is very likely to be the production of such a skin disease as that described. With regard to the treatment I am equally at a loss; our Editor states positively, that if cocoa-nut oil and turmeric are applied at intervals of two or three days, as soon as the *white comb* appears, it is a specific. In our correspondent's cases the disease is evidently beyond the reach of any local remedy. I should suggest the separation of the sick bird, a plain, unstimulating, wholesome diet—say of oatmeal and water, with a supply of green vegetables, and the administration of some alterative medicine, as flour of sulphur, ten grains, and calomel one grain, given every other night; or a three-grain Plummer's pill might be given instead. I should be glad of an opportunity to investigate the disease in any cases near town.

One slight error occurs in our correspondent's account respecting the moisture on the plumage in the morning. This cannot, as he suggests, be grease, as in that case it would not become dry by exposure to the air during the day. W. R. TEGETMEIER.

EARLY PART OF THE LIFE OF THE POOR MAN'S WELL-WISHER.

I WAS born of very poor parents; in fact, they were so poor that when I was two years old we were all in the work-house together, where we remained about one year; my father then obtained employment at the iron works in Staffordshire, where we all went to live; and I will now tell you the reason that I say all of us. My mother was the mother of fifteen children, and there are eleven of us living now; so we are not a very few. In about six years time the iron works failed, and we again came to the workhouse; and, as I was then nine years old, I was drawn apprentice to a farmer, but as I was very small the farmer gave an old aunt of mine £3 to take me off his hands, where I remained, by going to drive the plough, tend to bird scaring, to stock turnips, and so on, till I was fourteen. I was then off to service, and I do not think that ever I cost any of my relations twopence since; and it now remains for me to tell you how I have got on since that time.

The first thing that ever I tried to get hold of was learning. Now, I must inform you, that when I was a boy schooling was very dear; and, as I said before, my parents were very poor, so it was but a very little schooling that came to my share. But do you think that I was going to be a dunce because I could not go to school? Not I, indeed;—the greatest desire of my heart was to be a good scholar, and there was nothing going to be left untried that was likely to help me in gaining my object. The first thing that I had to do was to learn to read, and I will now tell you how I did this. I had a little Common Prayer Book by some chance, but who gave me that book I cannot tell, and our minister was so kind as to give me a little New Testament. Now, these two books were what I learned to read in. I had learned a little before, for my old aunt had taught me my A B C, and *a—b—ab*, and so on. Now, with these two books under my arm, you may depend upon my having gone to church as soon as ever Sunday came. If I did not, it was not my fault. Now, when I was at church, I was at school, and the minister was my schoolmaster. I always read on a little before the minister, and when I came to a word that I could not tell, I spelled it over, and when he came to it, his reading told me what it was, and I was then sharply off to another sentence, and so on.

So this is the way that I learned to read. In my next, I will tell you how I learned to write.

NORMANDY.

(Continued from page 171.)

THE way in which the English are regarded by the more retired inhabitants of Normandy is somewhat curious; there is a theoretical hatred, and a practical goodwill and kindness between the parties. The memory of the ravages committed by our nation during times of warfare still exists. Norman mothers, to the present day, quiet their turbulent infants by the threat that the English are coming, and will carry them away. Not that we have been more brutal enemies than any other set of men who carry fire and sword into a foreign country; but all warfare is dreadful, and we Englishmen, so long as we remain in England, have no conception what a horrible thing it is to be the seat of war. A Norman gentleman told me that when he was a little boy, he had heard from his nurses such frightful stories of these invasions, that he used to long to meet with an English boy, to beat and persecute him in revenge. But the remembrance of this traditional enmity in childhood did not prevent the display of much civility, and even kindness, to a representative of the once hostile nation. An Englishman who knows how to conduct himself properly will have little to complain of during his sojourn in any part of Normandy.

The Normans have the credit of driving hard bargains; but this talent is exercised quite as much at one another's expense as at that of "the stranger." I witnessed one or two pretty little instances of Norman cut Norman, with well-acted anger, followed by genuine reconciliation, and a strong contest after gross absurdities on both sides. It should be mentioned, that those travellers who land at Havre-de-Grace, and proceed by railway to Paris and back again, are not to suppose that they thereby know Normandy. Le Havre, as we ought to call it, has no character at all, unless we allow its own motley and Babel-like qualities to distinguish it from other towns in general; and it has the very disagreeable peculiarity of being, for France, excessively dear. But however grasping the Normans may be, the inns in the western departments are not exorbitant. A franc a day and night for a chamber, in which, if the floor is not all that could be wished, the bedding is always beautifully clean; a franc-and-a-half, or two francs for a mountainous breakfast; two francs, or two-and-a-half for a dinner to match, with a bucket of *boisson* each time if you like; and a franc a day, or less, for all sorts of attendance, ought not to be grumbled at. It is perfectly true, though scarcely credible, that in Calvados and La Manche you may travel half-a-day by the diligence, and when you get out, and give your carpet-bag to a porter, the *conducteur* will politely wish you good day, and *not* ask you to remember him—to my mind a memorable fact.

Last year, throughout Normandy, there were more apples than they knew what to do with; it was not easy, on the spur of the moment, to find casks enough to contain the overflowing supply of *cidre* and *boisson*. This year, people say that there are none, and that they shall have to drink old and *dry* cider, without much sweet or new by way of a change. The truth is, that the apple crop is very partial; in Calvados there are few, but about Avranches (a most rich and lovely district,) there are plenty; and the innumerable ungrafted pear-trees which line the roadside, are laden with their small, dark-green fruit, which will all help to replenish the cider-vats: so the lovers of *boisson* need not quite yet fear being compelled to take refuge in wine and water.

(To be continued.)

TO CORRESPONDENTS.

CHARACTERISTICS OF A BLACK BANTAM.—A good specimen of the black Bantam cock should not exceed fifteen ounces in weight; his characteristics would be a well-developed but regular and firm rose comb, terminating in a point behind, with face and wattles of the same bright carmine; plumage wholly black, with a metallic tint thrown over it of a rich purple hue, close-feathered; the flight feathers of the wing rounded at the extremities, and carried low; head fine, with a clear prominent eye; neck erect, and, when the bird is excited, so thrown back as almost to meet the tail, which latter should be full, and free from any stain in colour; its sickle feathers are seldom prominent till the end of the second year; back short, not more than two inches intervening between the termination of the neck hackle and the root of the tail feathers; breast wide and deep; thigh short and sinewy; shank clean, and of a dusky-

grey tint. The hen is of duller colour, and less striking appearance throughout. Her comb very diminutive, and in colour dirty purple; the shank of the leg is also darker than in the male; but in both cases a generally well-proportioned figure and erect carriage should at once arrest our attention. The cock possesses most indomitable courage, and the hens are excellent mothers; but our own pullets seldom laid before their eighth or ninth month. Dealers' prices, for good specimens, would range from one to two guineas each.—W.

GUERNSEY LILY (Inquisitor).—"How should this Lily be treated after flowering?" By casting the bulbs over the garden wall, and thinking no more about them; for they are of no more use in this country. If you keep them in the pots all winter, and give them plenty of air and water till the leaves are ripe, they would do for an emigrant to Australia. Any nurseryman will understand *Fairy Rose*, and send you a score for as many shillings. They are *Miniature Chinias*.

POLYANTHUS NARCISSUS (Old Hall).—Let your "very large" *Grand Monarque* Polyanthus Narcissus alone; it is doing very well indeed in putting forth its shoots. Give it abundance of water, and of air, but not much heat after the flower-stalks appear. After flowering, water it well, and turn it out of the pot, planting it in a very sheltered place; and if the weather is dry next April and May, water it once a-week, and next year you will have three large roots instead of one. No one can tell now if the three divisions will flower this year, but probably not.

COMMANDER-IN-CHIEF GERANIUM (Yorkshire Gardener).—Plant it out in the flower-beds, by all means, at the proper time; but why not make cuttings of the tops of the shoots early next March, and so have six or seven plants instead of one? The colour is most beautiful, and nearly scarlet. It is one of the best pot-plants of all the Horse-shoe tribe, and perhaps it would be as well for you to keep it in the pot all the summer, by plunging pot and all, and not neglecting to water it now and then, particularly at first.

EXPERIMENTS WITH POULTRY.—In No. 217, for November 25th, your correspondent, "Shanghae Mandarin," has given my opinion respecting the Gallic experiments; and, in addition to his statements, I have only to say, that I think fowls for such trials should be in the same condition; for it appears to me, from what "Gallus" says, that in all probability his Spanish fowls had finished moulting, and were in a state of rest, while one of the Shanghaes he admits was laying, and the others were most likely moulting; and while making new coats must require more food.—B. P. B.

PRONENESS TO SITTING.—A correspondent, in the same number, complains of the pertinacious desire to sit displayed by the Shanghaes. My plan is to shut up such hens that are broody, which I do not wish to sit, for a few days, giving them plenty of food and water; and they generally begin to lay again in about a fortnight. With respect to my Shanghae hens, if they persist in sitting in their confinement I move them, or coop them out in the yard, which has always overcome the hatching fever in three or four days. Allow them plenty of water, and do not starve them, as some recommend, as the better the hen's condition the sooner will she recommence laying.—B. P. B.

SICKLE FEATHERS IN SHANGHAE COCKS.—In the number for December 2nd, I see, in answer to "Brixton," respecting the tails of Shanghaes, the following—"but we are quite sure that cocks of the pure breed have no sickle feathers." Allow me to inform you that that "we," whether Editorial or Departmental, is in error. It is true the sickle feathers are small and dwarfish, but, nevertheless, are present in birds of full plumage, though I greatly suspect fashion causes some of them to be minus. My breed was kindly sent me by Captain —, the same from whom Mr. Sturgeon received his first stock; and he assures me they are pure. I have a cock from Anster Bonn, and two large dark red cocks, all of which have real sickle feathers, though small, not standing so high as they do in other fowls, and not readily distinguishable from the side-sickles. The sickle and side-sickle feathers are the primary tail coverts, the centre pair being the longest.—B. P. B. [We quite agree in this: what we understand by "sickle feathers" are those large curved ones in the tail of the Dorking cock.—Ed. C. G.]

FEEDING POULTRY.—The best way to feed fowls, or other poultry, in confinement, is to let them have food always at hand (if it can be kept from vermin). The reason is this, that after the first few days they become accustomed to find the food always before them, and only take a small quantity at a time, consequently, do not eat so much; therefore, it is cheaper than feeding at stated times, when they fill their crops as full as possible; and not to feed sufficiently is no economy, at least, if any return is looked to.—B. P. B.

PEAT CHARCOAL FOR CAMELLIAS, &c. (J. B. J.).—We have not used Irish peat charcoal as you propose, but there can be no serious objection to a little in the compost. Our nurserymen, however, do not dabble much in those things; give them a good fibrous peat, silver sand, and a sound mellow loam, and they can grow anything. Mr. Errington proceeds just the same for the *tying-down* system of pear-shoots as formerly; form is immaterial, distance the main thing. The leading shoots should be about ten inches apart; if parallel, all the better. Indeed, there does need caution in using sulphur on hot surfaces. You may smear it liberally on any pipe which never can become too warm to be held fast by the hand—say about six ounces to a thirty-foot long house, and of the ordinary width and height of a full-sized vinery. *Luculia gratissima* will be found to answer well in an intermediate house.

SOOT (Orchard).—I am glad that you have put the inquiry, and knowing that such was used on the strong clays of Derbyshire, I immediately wrote to my brother-in-law, who farms about three hundred acres there. The following is his reply, and I am sure it will interest hundreds. R. ERRINGTON.—"I have never used soot as a top-dressing for beans, but have done so with advantage on strong clayey wheat land, to wheat, oats, vetches, and grass, at the rate of three to four imperial quarters per acre. I find the best time for sowing is in March or April, in calm moist weather; it ought on no account to be sown in dry windy weather, or part of the dressing will be carried off to the adjoining land. The price paid by me is four shillings per quarter, and the sweep, at that price, comes to sow it when required. I roll as soon as the land is sufficiently dry. There is no danger of its being washed off, except by a heavy land-flood. I have not heard of any implement to sow it with. I should

advise those who have room to stow away soot, to take it in all the year round as the sweeps bring it (which they are glad to do even at a less price). You can measure it with your own strike, and prevent the impositions one is subject to on fetching it at the time it is wanted. I may here mention the tricks they adopt. In sending for soot, your man, however careful, is almost sure to be cheated. The sweep often carries the soot out in sacks, your man (or yourself, if you like it better) sees the first sack or two filled with proper measure, but such a dust is kicked up that it is impossible to breathe in the place; you then stand outside to see the number of sacks emptied into the cart or waggon, and the moment your back is turned, the sack is changed for a less one, and so you are defrauded. And if you insist on its being carried out in the strike, or bushel, some of the soot is trodden down in the bottom of the bushel, and *there remains*—only a part is emptied into the waggon. One scarcely ever thinks of measuring soot, as it is generally taken to the field and sown forthwith; but on one occasion, strongly suspecting there was not the quantity stated, I took the trouble to have it measured, and found I was attempted to be robbed of exactly 66½ per cent."

VINE GRAFTING (*W. Aigburth*).—We do not think it would be well to graft your vine now, at least, we never thus performed it. The general practice is to suffer the stock to be a little in advance of the scion. Perhaps you may venture towards the middle of the month. You do not say whether the head of the stock is to be cut entirely away, or whether you are only adding a graft to the side of an existing shoot. Vines take so readily by grafting, that it is almost impossible to fail. To avoid bleeding, rub white lead on the wounds, and cover the junction part with moss, to be occasionally damped.

UNFRUITFUL WALL TREES (*An Old Subscriber*).—Half the fruit-trees in the kingdom are ruined by border-cropping, or, in other words, annually destroying their surface-fibres. We allow no digging or forking for seven feet next the wall in full grown trees. Deep roots produce late growths, late growths ripen badly, and badly ripened wood sets badly. It could not be otherwise with tender trees. You must not allow what is vulgarly termed blight. Any crop, if you must crop it, for which six inches of digging will suffice, you must make up for want of depth by extra manuring.

SULPHUR PAINT (*G. R.*).—With such a dressing you may safely paint both walls and wood all over in the end of the month. You may double the amount of sulphur with benefit, and if the colour is too glaring, you may subdue it with soot; this is our practice. You may apply it to any tree about which a fear of insects exists.

HEATING PITS (*William Bird*).—We really cannot answer for your modified plan. These compromises sometimes have an awkward termination. It is our duty to point to principles, yours to carry them out. As to training Cucumbers and Melons, let us repeat they *must* enjoy plenty of light; the mode of training matters little, only do not let them grow at random. It will probably be necessary to give a paper some day on these minutiae. If William Bird was at our elbow, we would take him round the garden and point to matters at once, but really our columns are scarcely broad enough to follow that course which good-nature itself would point to.

POLAND AND HAMBURGH FOWLS (*A Poultry Fancier*).—There is no doubt about the distinctness of these, but you do not enumerate all the sub-varieties. If, as you say, the taste for Shanghaes is ill-grounded, the mistake will soon be found out by the natural good sense of our countrymen; but we differ with you entirely. When you have any *facts* to record we shall willingly publish them.

BOOKS (*B. H.*).—You had better wait for the new edition of Mackintosh; and instead of the other, buy *The Pine-apple*, one of the works published in the series called "The Gardener's Monthly Volume." It is to be had of Mr. Bohn.

POULTRY-HOUSE (*Rosa*).—You will have seen the plan of Mr. Punchard's; others of the cheapest construction will be published in the forthcoming work on Poultry, and we shall borrow a plan from it. Galvanized iron net-work is the best, and cheapest in the end, of all the materials usable for Poultry enclosures. Three feet high for Shanghaes, and six feet high for other varieties is required.

POTTING SAND (*J. B. P., Dublin*).—The Killiving sand will answer excellently for potting purposes.

TETRAEUCIA PRUNING (*Ibid.*).—This will want no pruning, unless forced to grow in heat. The stopping of a shoot, by pinching out its point, will be sufficient. When grown in an airy house, that will seldom be required when the plant is established, as it is truly a continuous bloomer, and will throw out side-shoots as it extends in height. When a plant becomes straggling, you may prune it back with safety, provided you do not cut back into wood above two years old; but after the operation, you must keep the plant closer and warmer than usual before it breaks, and then expose it to plenty of air by degrees. For *Eutaxia*, *Westringia*, &c., see Mr. Fish's paper of to-day.

STRAWBERRY FORCING.—*Amateur* writes thus:—"I have at this time several strawberry plants (out-of-doors) in bloom, and just coming into bloom (Myatt's Prolific Hautbois); would it answer to take up some and pot them in 32's or 24's, and put them in a forcing-pit? There is not the slightest chance of doing any good with them. They are in bloom all over the country.

VINES, IN POTS, FROM EYES (*An Amateur, Dublin*).—Your seven questions involve such long answers that we must be excused for answering only one of them in each week; and we begin with vines in pots, for which you modestly ask a treatise, to include "all particulars," from the "striking of the cuttings to bearing." With good gardeners this takes about two years or thirty months. Get plump eyes from well-ripened shoots in readiness by the end of next February, then have a gentle hot-bed ready with a steady bottom heat of 80°; take sixty-sized pots, and fill them with rich light compost of one half loam and the other half of leaf mould and a little sand; plant a single eye in each, plunge them in the bed, keep the soil a little moist, and do not let the air in the bed get hotter than 65° until you have the eyes in leaf.

BLACK SHANGHAES (*E. Bateman*).—We cannot inform you who has any for sale. Those who have must advertise them. The following letter, just received, however, may be of use to you:—"I must beg to differ from your correspondent 'T. A.,' who states that 'there are no Black or pure White thoroughbred Shanghae Fowls in England.' I am now in possession of *both*, bred from birds imported twelve months

since; and a friend of mine, residing in this neighbourhood, has a pair of *pure* white, thoroughbred Shanghaes, Should 'T. A.' persist in his opinion, I shall be happy to do all in my power to convince him of his error; and, doubtless, my neighbour would do the same.—W. LOBT, Ward End, Birmingham."

DISEASE IN PIGEONS.—*J. T.* says:—"I should be greatly obliged if you, or any of the correspondents in your paper, could inform me the cause, and cure (if any), of a lump or core which comes in the throats of some pigeons, generally at from a week to three weeks old, and in most cases is fatal, by preventing them swallowing or breathing. During the last season I have had quite half my young ones die from the above disease. Has the water, which is hard and chalky about here, anything to do with it? But I have occasionally had them die when I kept them in London, of the same disorder; but then it could not be the water; and as some of my birds are very valuable it is a great loss." For information relative to *White Comb* in Shanghaes, see a case in another page of this number.

FAIRPLAY.—We have a letter sent to us for our correspondent who wrote to us under this signature, at page 212 of the present volume.

ERRATA.—At page 110, col. 2, line 20, for *end*, read *one*. Line 46, for *limited*, read *united*. Line 70, read *Gelieu*. Page 111, line 7, for *auspicious*, read *suspicious*.

CHARACTERISTICS OF THE SILVER-SPANGLED HAMBURGHS (*A Constant Subscriber*).—The cock should have a full, but firm and erect rose-comb, terminating in a point behind, large wattles, and a white earlobe; ground-colour clear white; the extremity of each feather of the body being tipped with black, hence their synonym, *Moonies*; wings regularly barred,—a point now much insisted on; tail full, with but a small admixture of white in its sickle feathers; bill short; body neat and compact; legs clean, and in colour pale blue. The hen's markings should be even more distinct than those of the male bird, the outer edge of each of the flight feathers being delicately margined with a dark line instead of barred, and the tail tipped only with black. In both sexes the colours should be clear, and in no way blended, or run one into another. We did not observe the faults enumerated by our correspondent in the prize birds of this class at Birmingham, for an imperfect comb alone, such as he describes, would at once bar all chance of success; but the class there was not one of peculiar merit.—W.

GOLDEN-SPANGLED HAMBURGHS (*Omega*).—The feathers enclosed are those of well-coloured Golden-Spangled Hamburgs; their provincial appellation of "Bolton Bays" will, in this case, be readily understood from the brilliant ground-colour. The "*Dull-black and ochrey-brown*" alluded to would betoken a very inferior strain of this variety, which was well represented at the last Birmingham Show, and from the winners on which occasion fresh blood might be advantageously introduced. Though the birds may have been sold to you as "Copper Moon Pheasants," they are true Golden-Spangled Hamburgs.—W.

FECUNDATED EGGS (*Avogus*).—We certainly should have no faith in any one's directions for deciding whether eggs are impregnated from their specific gravity. The test, therefore, of "putting them in a bowl of water, and rejecting such as do not sink to the bottom," we believe valueless. Our own opinion is, that in the fresh egg, whether impregnated or unimpregnated, no difference is found till after incubation has begun; then, when broken, the membrane of the fertilised egg is found opaque, the cicatrula, or punctum, well-marked, and the surrounding zone brilliant. Other points of difference might be mentioned, but they would require microscopic aid. The mark, or appearance, in the egg to which you allude, is probably its condition when placed between the eye and a strong light after it has undergone a week's incubation; the embryo in the fertilised egg will by that time have assumed a distinct form, easily discernible from the state of a clear egg.—W.

FURNISHING A CONSERVATIVE WALL (*A Brighton Subscriber*).—You have put up a conservative wall on the north side of your stove-house, and you wish to have some plants placed against it that will furnish your lady "with cut flowers plentifully at Christmas," and they are to be very useful, very beautiful, and very uncommon. It is no easy task to inform you of any plants that will do all this for you. *Camellias*, you say, will thrive in it you know; and if so, what can you have better to cover your forty feet long wall. However, if you wish for variety, add one or two of the following:—*Azalea indica alba*, *Escallonia macrantha*, *Daphne hybrida*, *Daphne indica rubra*, *Coronilla glauca*, *Chimonanthes fragrans* and *grandiflora*, *Deutzia gracilis*, an *Orange-tree*, and a sprinkling of *China* and *Perpetual Roses*. If you were to cover your wall with glass, you might extend the list greatly, as there are many plants now grown in greenhouses that would live and flower well under glass against a conservative wall; a list will be published shortly. There are some other shrubs that would live and flower against your wall, but as you wish for winter-flowering ones, the list here given will answer the purpose from December to April.

PLANTS FOR A WARD'S CASE (*Ignoramus*).—You have a Wardian case, 2 ft. 6 in. long, by 1 ft. 3 in. wide, and 1 ft. 8 in. high, with a box 6 in. deep for soil. You wish to know what sort of soil to put in this box, and what kind of plants will grow in the case. You would wish to have some flowering plants as well as *Ferns*. Now, we can assure you, from dear-bought experience, that no other plants excepting *Ferns* and *Lycopodiums* will live for any time in such a case. They will live and flower, if already in bud, for a few weeks, but then they invariably damp off, even with plenty of air on favourable occasions. Be content with what we recommend, and you will succeed. *Ranunculuses* would damp-off in a fortnight. *Hyacinths* might last a little longer; and *Cactus truncatus*, if provided with buds would expand them, but would never produce any more. The soil you should use is the siftings of heath mould or peat, with a small admixture of very turfy, fibrous loam, and a small portion of silver-sand mixed through the whole. It is advisable to have a thin layer of broken crocks spread over the bottom of the box for drainage.

WEEKLY CALENDAR.

M D	W D	JANUARY 13-19, 1853.	WEATHER NEAR LONDON IN 1851.				Sun Rises.	Sun Sets.	Moon R. & S.	Moon's Age.	Clock aft. Sun.	Day of Year.
			Barometer.	Thermo.	Wind.	Rain in In.						
13	Th	Salpingus roboris; bark.	29.538—29.443	50—39	E.	24	3 a. 8	15 a. 4	8 49	4	9 7	13
14	F	Salpingus rufirostris; bark.	29.739—29.701	51—39	S.W.	16	3	16	9 58	5	9 29	14
15	S	Apion Ulicis; furze.	29.602—29.455	56—44	S.W.	26	2	18	11 7	6	9 50	15
16	SUN	2 SUNDAY AFTER EPIPHANY.	29.840—29.703	52—37	S.W.	07	1	20	morn.	7	10 11	16
17	M	Monotoma juglandis.	30.241—29.951	47—24	W.	—	0	21	0 15	8	10 31	17
18	Tu	Rhagium vulgare.	30.326—30.276	44—22	S.W.	—	VII	23	1 23	9	10 50	18
19	W	Notonecta furcata; ponds.	30.141—29.980	47—28	S.	—	58	24	2 30	10	11 8	19

METEOLOGY OF THE WEEK.—At Chiswick, from observations during the last twenty-six years, the average highest and lowest temperatures of these days are 41.7° and 31.2° respectively. The greatest heat, 60°, occurred on the 19th in 1828; and the lowest cold, 4°, on the 14th in 1838. During the period 103 days were fine, and on 79 rain fell.

THE STIFF CEANOTH.

(*Ceanothus rigidus*.)



THIS is one of the genera included in the order of Rhamnads (*Rhamnaceæ*), which appear to be confined to particular countries; all the true Ceanoths are natives of North America and Mexico. *Phyllicas* are found only at the Cape, and *Pomaderris*, with *Cryptandra*, in a wild state, are not met with out of New Holland. The genus was first named by Linnæus, and subsequently Rafinesque called it *Forrestia*, a name which obtained currency among authors. It belongs to Pentandria Monogynia, class and order of the Linnæan system. It is figured in the *Botanical Magazine*, t. 4664.

Ceanothus rigidus was discovered in 1848, by Mr. Hartweg, in open woods, near Monterey, in California, by whom seeds of it were sent to the London Horticultural Society, who distributed plants of it freely among the Fellows. It was originally discovered, however, by Nuttall, who named and described it in Torrey and Gray's *Flora of North America*, vol. i. page 268. It is an upright, stiff, branching evergreen bush, growing from four to six feet high; the young branches are downy; the leaves small and dark green, smooth and shining on the upper surface, and spiny-toothed on the edges; on the under side they are pale green, and

strongly netted. The flowers are produced in dense small clusters at the end of stiff, short spurs. They are deep purplish-violet, very rich when viewed closely, or under a bright sun, but not very conspicuous at a distance. In this country the plant flowers in the spring, and is perfectly hardy in the climate of London, and in the climate of Devonshire would equal in vigour the other North-west American *Ceanothuses* as thus described by the Bishop of Exeter, when writing to Sir W. Hooker, in May of 1852. "The *Ceanothus divaricatus* is now in its highest beauty; the largest plant is eighteen feet high, eighteen feet wide, twelve feet thick, covered with thousands of the beautiful thyrsoïd (bunch-of-grape-shaped) flowers, so that the leaves are scarcely visible. *C. rigidus* blossomed about six weeks ago; *C. dentatus* is now in full flower; *C. papillosus* is just coming into flower; *C. azureus* will not blossom until August."

B. J.

Propagation and Culture.—No plants can be more readily increased from cuttings of the small side-shoots than the "New Ceanothuses," as they are called, of which this is one. These cuttings will stand as much top and bottom-heat as *Fuchsia* cuttings; that is, ten or fifteen degrees more than is safe for a Pine-apple, or a Cucumber plant. They will also root freely in any degree lower than that, till you come to the common hand-glass on a shady border, or even without the aid of glasses, behind a north wall, if they are put in from August to October. I am not aware that this species has ripened seeds in this country yet. No soil can be too rich for this plant, nor too shallow, nor too dry at the bottom; I mean not too shallow within reason—say nine inches deep. When the soil happens to be deep, deeper than twenty inches, with a moist bottom, it cannot be too poor for any of the true *Ceanoths*; and here is the reason for both sides of the question. This species, as the name implies, is a stiff-growing plant, the greatest part of the side-branches being merely fruit-spurs, as Mr. Errington would say. Now, a very rich border, twenty inches or two feet deep, such as a good old-fashioned vine-border, would force this stiffish gentleman to give up its Californian habit, and come out more freely in all its parts; but then, on the other hand, this high feeding would be certain to cause the plant to continue its forced growth too late in the autumn, when the chances are, that a sharp winter would kill it in the north, and injure it more or less everywhere. As far as I know, this is the only species of the genus that could be improved in this country by a judicious course of high feeding with liquid-manure, early in the season, provided that the border was shallow, and the situation favourable. All the other species of *Ceanothuses* grow so freely in any good garden soil, that it would be injurious to them to enrich it artificially, and so prolong their growing season in the autumn. Since I began this article, it occurred to me that a review of the whole genus might be useful and interesting, and I will prepare my notes accordingly.

D. BEATON.

THE extraordinary high price now giving for the best varieties of Dessert Pears is rousing attention to their growth, and we have before us numerous inquiries asking whether they are more difficult of cultivation than the Apple? Whether they are less hardy? Whether

they are shy bearers than Apples? with other questions, all demonstrative that a movement is making, or intended, to their more extensive cultivation. This is as it should be; for there is no reason whatever against such an increase in their numbers. In fact, the reasons

are all in favour of such increase. We have already given lists of those superior varieties which are to be preferred for standards, and other lists will follow of those kinds which are to be selected for wall-culture. Let us add, that on walls they are a much more certain crop than either Peaches, Nectarines, or Apricots, whilst they fetch prices quite as remunerative. Instead of struggling against adverse circumstances, and wasting labour and years in the endeavour to steal a scanty crop now and then of those natives of warmer climes, in spite of our ungenial seasons, we advise all those who covet either a more certain or a better compensating crop, to devote their walls to the best varieties of French Pears.

It is more than strange that neither here, nor in any other country than France and Belgium, has a careful culture and a firm pursuit of the improvement of this delicious fruit been attempted; for it is a fruit native of every district of Europe, and has been cultivated from a period very remote.

The Hebrews knew it only in its wild state (*Agas*), but Homer places it among the fruits of the garden of Alcinoüs:—

“The branch here bends beneath the weighty pear,
And verdant olives flourish round the year.
The balmy spirit of the western gale,
Eternal breathes on fruits untaught to fail:
Each dropping pear a following pear supplies,
On apples, apples, figs on figs arise:
The same mild season gives the blooms to blow,
The buds to harden, and the fruits to grow.”

Beyond the fact of the ancient Greeks having this fruit in cultivation we know nothing; but when we descend a little lower in the order of time, we find among the early Romans not only a very accurate knowledge of its cultivation, but that they had many varieties, distinguished by names which told of their quality, their place of birth, or their first owners. Thus Cato, who lived half a century before the birth of our Saviour, enumerates, as the most excellent of Pears, the Voleman, Anicianan, and Sementivan; at the same time characterising the time when winter had quite departed, as being “when the Pear begins to blossom.”

Columella, Pliny, and others, are still more copious in their lists of Pears; and some modern fruitists have endeavoured to identify these with varieties at present known to orchardists. Without expressing any assent to these identifications, yet we think they are not without interest; and we would not have the man for our friend who does not care to know that he is partaking of fruit descended from trees of which Pliny, Cicero, Varro, Columella, and Virgil, may have enjoyed the produce.

To aid our readers in the enjoyment of this pleasant possibility, we will trace out some particulars which Dalecamp and others have suggested upon this subject.

Columella says: “We must be careful to plant our orchards with the most excellent and fruitful Pears. They are these:” *Crustumina*. This was so called from Crustumium, in Hetruria, where it was most cultivated. Pliny says it was of most grateful flavour; and Servius says it was small and partly red. Supposed to be our *Petit Blanquet*, or Little Blanket.

Regia, or Royal. Pliny says its stalk was so short that it grew close to the branch, was oblong in form and green in colour. Dalecamp considers it to be the *Carmaignole*.

Signina. So named from Signia, in Italy. Pliny says it was by some, from its appearance, called *Testacea*, or Brick-coloured. Dalecamp thinks it is the Cat Pear (*Poire Chat*).

Superba. It is small, says Pliny, but it is the earliest. Hardouin and Dalecamp agree that it is our *Little Muscat*.

Ordeacea, or Barley Pear; because, says Pliny, it was ripe in barley harvest. It is thought to be our St. John's Pear, or *Amiré Joannet*.

Favoniana. Pliny says it was red, and a little larger than the *Superba*. Dalecamp and Hardouin think it is our *Great Muscat*.

Lateritana. Probably from its brick-red colour; is supposed to be the *Poire Prevost*, or Provost Pear.

Dolabelliana, was named after a Roman citizen, and distinguished for its excessively long stalk. Dalecamp thinks it is our *Musette d'automne* (Autumn Musette), or *Pastorale*.

Venerca, or Venus Pear. So called, says Pliny, from the beauty of its colours. Dalecamp says it is the *Poire Acciole*.

Onychina, the Onyx Pear, from its purple tints. Dalecamp thinks it is the *Cuisse Madame*, or *Jargonelle*, of our gardens.

We might extend this catalogue twofold, but, after remarking that though the Romans paid such attention to the Pear, it is entirely neglected by the degenerate race now occupying the territory of the Seven Hills, we will next pass on to the consideration of what has been done to improve this fruit in more modern times.

No building could well be more suitable, in every respect, for a large poultry exhibition, than Bingley Hall, Birmingham; and if we now hazard the opinion that the arrangements, in some few points, might still be susceptible of improvement, it is only from the fact that occupying, as that show undoubtedly does, the post of honour, and being consequently the model for imitation, all should be as near perfection as may be.

Where light is, as there, admitted by skylights, a great loss of effect will ever be caused by having two tiers of pens one above another. This was evident at the last exhibition, where the Game fowls and Hamburgs, elevated aloft in the central avenues, had greatly the advantage over their more august neighbours below. True, there was no help for it, and the committee, with upwards of 1300 pens to provide for, made the most of the room allotted them; but in the smaller county exhibitions this may be kept profitably in mind; and, wherever it is practicable, single rows of pens will always be found to do most justice to the birds, be they of what race they may. In the double row it inevitably happens, where both are at all visible, that the first is lower, and the second higher, than they should be.

About two feet ten inches seems the level most to be desired for all purposes.

A petition for wider alleys between the lines of pens might be met by the same answer—Where was there room for it? But on other occasions, where the candidates do not muster in equal force, the argument that what was sufficient at Birmingham will be sufficient there also, might prevail, even though space was at hand for a clear passage of at least twelve feet. Feelingly do we give evidence that a large majority of the Birmingham spectators would cheerfully assent to such an alteration, could it possibly be so managed; but were it practicable to hold the poultry and cattle shows at different times, what luxury of space would be attainable! Every bird might then be disposed with full effect; and though we know not how our bovine and porcine friends would treat such a proposal, the poultry interest we are quite sure would not suffer. Some room, we think, might be gained by a reduction of the depth of pens; for supposing them, for fowls generally, to be three feet wide, two feet-and-a-half in depth would be amply sufficient for the threes and fours that are now exhibited, and save many a poke from the sticks and parasols of inquisitive beholders. All managers of future exhibitions will do well to follow the example here afforded, and secure the pens from any risk of cold draughts of wind, than which nothing can be more injurious. Ventilation from above is of course the most efficient precaution against anything of this kind.

Would not dry sawdust have been a better material for littering down the pens than the red ochrey sand that so besmeared the plumage of the white and light-coloured birds? And, in respect of food, might not a portion of *boiled* grain be found most useful, both as regards the digestive organs, which are likely to have their powers somewhat reduced during the *long* period of confinement, as also when we remember the very stimulating character of the diet on which, generally speaking, the fowls have been previously fed? Now, boiled grain is both very tempting and very wholesome, and would be greedily taken when the most seductive mixtures of barley and oatmeal failed to excite the appetite.

This leads us to an earnest appeal on behalf of that portion of the feathered race who are summoned together on these occasions, that the period of exhibition should, if possible, be abridged. We do not presume to lay down any exact regulation as to how long this, to them *durance vile*, should last; but we think that under no circumstances would it be necessary to exceed two days for exhibition, with two more for the labours of the judges, and the fowls' dismissal to their homes; thus four days in all would be quite long enough to detain them in a condition so contrary to their usual state; and we believe that we are not wrong in thinking that many owners of valuable birds are strongly of our opinion. The mere pecuniary question is another matter, which we are not competent to enter on; but, if report speaks truly, the Birmingham Society might possibly afford to set us another good example in this respect, as it has already done in so many others.

The impression produced on us by the continuous line of Hamburgs, Polands, Dorkings, and the varieties of Shanghaes, thirty or more pens of birds of the same form and plumage succeeding each other—though, of course, unavoidable—led us to speculating as to what could, probably, constitute the most perfect and, at the same time, most “*eyesome*” (to use a Cornishism) representation of the different varieties of fowl. Now, some six pens or so in each class would, I imagine, save the eye from being thus wearied with what, however excellent, proves at last monotonous, and would also combine, when carefully selected, every point of excellence that the several breeds could boast of. With the stimulus that poultry-keeping has lately, and still continues to receive, we cannot but think that such a scheme may be within the verge of *possibility*, and that, too, at no great distance of time, though, of course, on a perfectly different footing to any of our present meetings.

To facilitate intercommunication, we would also suggest for adoption at the Birmingham, and all other large public exhibitions, that an “Address Book” should be kept at the secretary's office, in which any visitor might enter his name and place of sojourn. We know many men from distant parts of England who would have rejoiced to interchange civilities at Birmingham, if they had known of each other's presence and whereabouts.

But, after all, what we have been talking about, a little more space, a little more alteration in the pens, some sawdust and boiled grain, form the catalogue of all the minor points we can manage to find fault with at Birmingham; and the only pretext for dwelling so long on these comparatively trivial matters is, as we before observed, the certainty that the Midland Counties Poultry Meeting has been, and, as we hope, will long be, regarded as a safe model and authority for the guidance of its juniors; and thus even such minutiae as we have alluded to become deserving of our careful consideration. But there are such individuals as judges, and there are, too, such facts as their decisions—awful topics—only to be approached with awe and trembling; nevertheless, having got so far, to retreat is out of the question, and, in plain terms, we must have it out.

Imprimis—let us remember, that to pronounce upon 1300 pens at Birmingham, without adding the pigeons, who were separately provided for, four gentlemen were occupied for thirteen hours. Now, without saying another word, the mere bodily fatigue and anxiety to arrive at a correct decision that must have inevitably accompanied such continued labour, entitles them to our best thanks, and should be amply sufficient to account for any little difference, should such be found to exist, between their awards and our own pre-conceived, and often rather obstinate, opinions of what may seem most in consonance with our own ideas.

We are merely speaking of what took place at Birmingham, as of what *may*, and does take place, in a greater or less degree, at every Poultry Show. Let us grant the decisions to be just and fair; but we ask, is not the labour excessive; and is it possible that those classes that come before them at the *thirteenth*, not the

eleventh, hour, can profit by their knowledge and experience in the same degree as those that occupied the earlier morning?

Many are of opinion, and we are of the number, that the decisions of a single judge have several points to recommend them. He may be selected with a special view to the classes to be entrusted to his judgment; he feels that no other shoulders than his own will share the responsibility, so that there is the greatest inducement carefully to estimate every point at its proper rate. Now, supposing these four gentlemen at Birmingham had each had their 325 pens, or, if such sub-division be objected to, each two had had 650, their awards would surely have been completed at a much earlier hour, and a double benefit of a saving of fatigue to themselves, and some limitation of the poultry's occupancy of their pens might thus have been obtained.

It has been our unpleasant duty to condemn what we consider errors in the appointments of judges, as well as errors in their decisions; and we have been told that our condemnation has not been sufficiently severe. We differ totally in that opinion, and for many reasons. Let it suffice for us to say, that we have a conviction which nothing can loosen, that if that very unenviable office of judge at these exhibitions is to be filled by competent persons, public confidence must be accorded to them, and their decisions once announced, individual criticism should be very tender in dealing with the awards, even when a mere difference of opinion as to relative merits may be the point in question. But when, on the other hand, strong facts and clear evidence would warrant the probability of partiality, or other injustice, then there is but one course to be taken by the dissentient, by an appeal to the committee, or managers, with the production of the evidence on which the charge is made. This is no less due to the calumniated party, than to the Society, its exhibitors, and the public at large.

We are not here speaking of the Midland Counties Exhibition *particularly*, but of all *generally*; not retrospectively, but as intimating the course that justice would point out when such questions might unfortunately arise. Few will hesitate to admit, that, whatever its distinction, the judicial office on such occasions has a larger share of responsibility attached to it than is lightly to be undertaken. Any steps, therefore, that might serve to reduce that responsibility would be in the right direction. Now, we have long thought that through the means and concurrence of the committees and managers of the different Poultry Societies, and the assistance of the large breeders and exhibitors which would be readily rendered, some standard might be gradually arrived at, according to which the points of excellence, properties, and characteristics of every member of the poultry-yard might be at length defined. We may be thought, perhaps, over-speculative in advancing such an opinion; but, although positive unanimity could not be, at first, hoped for, yet we strongly believe that there would be far less difficulty in carrying out such a scheme than a first thought on the subject may suggest.

The great difference of opinion as to rival claimants for the honours of the prize list will usually be found to arise, not from the question as to what should be regarded as points of excellence, but from that of the relative proportion in which each may be regarded as possessing these same points. At present, however, great confusion prevails; and constantly is it asserted, that awards have resulted from peculiar notions of merit, and rules for decision. The part of a judge, were he able then to refer to such a standard as we have suggested, and say "Here is my authority for requiring such and such points in a bird; and my judgment, therefore, is only exercised in pronouncing which competitor possesses these points in the highest degree,"—the office would be less reluctantly assumed, and its decisions more generally satisfactory than they now appear.

Many who are fully alive to the great benefit that would result to all who are any way concerned in these pursuits from the institution of such a standard of excellence, yet dread the difficulty that may exist in the way of its being practically carried into effect; but on that plea we might just as well make up our minds to the perpetuation of the Income Tax, or any other abomination, if no attempt is to be made towards improvement, because our path may not be free from all obstructions, and the horizon may, at times, be clouded over.

Look at what has been done within the last few years in this branch of domestic economy, and who shall say that there is not good encouragement for a still further advance, both as regards the improvement of our stock, and the more systematic arrangement of those details to which we now look for the further development of excellence, no less with respect to profit than appearance.

Many, we believe, and those the most competent, would lend their judgment to this work, difficult as the scheme may at first be thought, and THE COTTAGE GARDENER would ever be at hand as a zealous ally.

W.

COVENT GARDEN.

If a butcher, or baker, is found cheating the public by using false weights, he is taken before a magistrate, and fined; he loses his reputation for honesty, and his business suffers. In almost every department of trade the law has, in this respect, made provision for the protection of the purchaser. It matters not by what name the measure may be called, it is requisite it should contain what it is professed to supply. A *quarter* of wheat is eight bushels; a *last* of rape-seed is ten quarters; and whoever makes a purchase at Mark-Lane of a quarter of wheat, or a last of rape-seed, expects and insists upon receiving his eight bushels or his ten quarters. So is it in all commercial transactions with which we are acquainted. But we are sorry to find that Covent Garden Market is either beyond the reach, or is placed in defiance of all law. If we buy a bushel of apples, we of course expect to receive a bushel, even although they may be measured in a wicker

basket. An unconditional bushel means imperial measure of four pecks; but such does not seem to be the case in Covent Garden, as we have in several cases lately been obliged to learn. We know there are some of the measures made use of in the vegetable and fruit markets—such as the *pottle* and the *punnet*—which have a vague and indefinite signification; and we should have been induced to think the same of the bushel also, had we not discovered a system of deception and roguery which has become too general, while at the same time purporting to supply imperial measure. In every instance which has come under our notice we have found the bushel basket to be filled about one-fourth of its depth from the bottom with straw, and the quantity of apples which are obtained is barely three pecks. Now this is a state of things which ought not to be permitted, and one which calls loudly for the interference of the proper authorities. Why should the public be robbed of their fruit with impunity, any more than of their sugar, or tea, or beef, or bread? It would be well if some one who has time and ability would give heed to this matter. It requires only to be inquired into, and the proper machinery to be set in motion, to have the nefarious system abolished.

The continuance of the present unseasonable and unfavourable state of the weather is operating very much on the trade of the markets, and the consequence is, the sales of every description of produce has been heavy. The supply of fruit continues good. APPLES do not realise such high prices as during the last few weeks; good-looking varieties being to be had at from 4s. 6d. to 7s. 6d., and dessert from 6s. to 8s. per bushel. The sorts which have been most plentiful are the old *Royal Russet*, which is an established favourite; the *Winter Greening*, or, as it has been called of late years, the *French Crab*, is also an old and excellent keeping apple for kitchen use, as it continues in use as long as April and May, and, in some instances, when well kept, even as late as June and July. The *Hanwell Sourcing*, a valuable sauce apple, is also pretty plentiful. There are also several parcels of *Alfriston*, *Blenheim Pippin*, *Golden Winter Pearmain*, and a few *Beauty of Kent*. We do not recollect ever seeing so few *Nonpareils* as this season; they are understood to be very scarce. An excellent dessert apple, which is largely grown in Surrey, called the *Cockle Pippin*, has appeared during the last week or two pretty plentifully, and meets with a ready sale. *Newtown Pippins* and *Lady Apples* are plentiful. In PEARS, we have nothing new; and of what there is, the prices are such as to keep the supply equal to the consumption. The sorts are still, *Nelis d'Hiver*, *Beurré de Rance*, *Passe Colmar*, *Chaumontel*, *Easter Beurré*, *Ne plus Meuris*, and a very few *Duchesse d'Angoulême*. GRAPES are scarce, and obtain great prices. *Black Hamburgs* make from 5s. to 7s. 6d. per lb. *Muscat of Alexandria*, 10s. 6d. to 12s. 6d. per lb.

VEGETABLES continue in abundance, the prices being the same as quoted in our last report. Forced *Sea-kale* and *Rhubarb* are more abundant, and *Asparagus* has, during the past week, been pretty plentiful, but very

small and weak. New *Potatoes* are being offered at one shilling for a small basket, containing about a pint-and-a-half, or little more. We also observed a few forced *Mushrooms*.

CUT FLOWERS and PLANTS IN POTS are in great profusion. The former are of a more choice description than we have been accustomed to hitherto, being all the production of the greenhouse, stove, or forcing-house. They consist of *Camellias*, *Azalea indica alba*, *Danielsiana*, and *Lateritea*; *Cytisus racemosus*; garlands of *Passiflora Kermesina*; spikes of *Euphorbia jacquini-flora*; heads of *Poinsettia pulcherrima*; and bunches of *Lilac*, *Lily of the Valley*, *Primulas*, *China Roses*, *Geraniums*, *Violets*, and *Orange Flowers*. H.

THE following is a list of the *Poultry Shows* of which we are at present aware. We shall be obliged by any of our readers sending us additions to the list, and giving the address of the Secretaries.

DONCASTER, January 21st. (Sec. H. Moore, Esq.)

GREAT METROPOLITAN, January 11th, 12th, 13th, and 14th. (Sec. W. Houghton.)

REIGATE, February 1st and 2nd. (Sec. J. Richardson, Esq.)

TORQUAY, January 14th and 15th. (Secs. A. Paul, and J. C. Stack.)

STRAWBERRY FORCING.

THERE can be little doubt that with the extension of glazed structures (consequent on their cheapness as compared with former days) the forcing of the Strawberry will obtain an increase of patronage; and, if we may judge by the character of the inquiries made concerning them, they are as little understood as any of our forced fruits. We lately received a query from a subscriber to THE COTTAGE GARDENER throwing some light on what we mean. The writer, it appears, wanted ripe strawberries in February, and had purchased some plants for forcing of some gardener, or tradesman; and these, it appears, were simply runners pulled from the heels, and stuck into pots, when they immediately assumed the dignified title of "forcing strawberries;" and doubtless the increase in their price corresponded with the dignity of their improved position. Now, we are afraid to say what we think of the tradesman, if such he be, who could be guilty of such a transaction, provided that the unwary purchaser stated his objects properly.

Let it be understood, then, by all those who aspire at proficiency in this proceeding, that no success can be expected from strawberry plants unless they have been duly prepared for the purpose; and we may here briefly state in what that preparation consists. The first object is to obtain early and stout runners; but, whether stout or not, they *must be early*; and to this end it is good practice to keep a row purposely to breed from. We have known this done many years since, and, indeed, have ourselves practised it; and care must be taken to make a bed on each side the row, in March, for the young runners to nestle and root in. This was done by breaking the surface up, and applying a surface-dressing of rich old manurial matter—that from an old hotbed of the previous year, composed originally of dung and leaves, is excellent. This, chopped well, and scattered three inches thick for a yard on each side the row, will speedily produce strong runners. Care should be taken, when the strings which produce the runners first ad-

saucers, to train them carefully, so as to cause them to produce the runners at pretty equal distances. By the early part of June the runners should be nicely rooted, and, to facilitate this, frequent waterings must be had recourse to previously. And here we may observe, that some prefer to pot them at once, and some to grow them on in a nursery. Our own opinion is, that for *very early* work the immediate potting is best; but for heavy succession crops the nursery culture is to be preferred. If potted, they may as well be put in the full-sized pots at once, which is generally the seven-inch pot, one plant in a pot, although some have two or three. Now, it is of much importance to use a proper soil for them, and, as usual with us gardeners, loam is the first thing thought of. We have known people to use a light soil, full of old manurial matters, with the idea of getting much finer fruit; but this is not safe practice. In houses, or pits, where there is a very regular amount of atmospheric moisture, this may answer; but such a soil is too capricious for ordinary cases, and thus we gardeners so frequently vote for loam, which to some seems inexplicable.

A good sound loam, rather inclined to adhesiveness, is the chief material then, for such parts with its moisture in a steady way; and Strawberries, especially after they come in bloom, may not be quite dry for an hour. However, a compost of three-parts of this loam, and one-part good rotten manure, thoroughly mixed, fairly may be recommended. Some use soot in the compost, or in the bottom of the pots: this we never proved. We may now add, that after potting they must be regularly attended to as to watering, and all runners produced by them assiduously cut away, but never one leaf plucked. They should be plunged above the ground level, in a thoroughly open situation, and once or twice during the summer the pots turned a little, to check their tendency to root through the bottoms of the pots. Liquid-manure may be frequently applied whilst they are in active growth, clear and rather weak.

And now as to those planted out. A perfectly open situation must be chosen, and the ground being in good heart, or manured, they may be planted out at from nine to twelve inches apart: we should prefer a soil shallow, but rich. Some of the best crowns we ever knew were from a walk converted into a temporary bed by covering it with six or eight inches of rich soil. These grew rapidly until their roots came in contact with the hard bottom, when they became somewhat stationary, and the consequence was, firm, plump, and well-ripened buds, which produced very fine trusses of flowers under the forcing process.* Thus it may be seen that the object should be to produce a *very early* and luxuriant plant, and so situated as to discontinue active growth about the beginning of September.

Our readers must know that, in these respects, the Strawberry is amenable to the same influences as the Peach, the Vine, &c.; a well-organised bud of the previous year being alike necessary to the production of good fruit.

We must now advert to the forcing process. And, first, what conditions does the Strawberry like, and what dislike? Having, as before observed, good, strong, and well-ripened crowns or buds, let their first stages in forcing be taken in a very gradual way. Better let them be started—if we may apply such a caustic term to a mild process—in a frame that has scarcely any pretensions to heat. Now here, in the mind of the ingenious reader, may arise a question such as this—Does the Strawberry, in its native character, really require a decided rest, or does it not? Now, it appears to us, that much is contained in such a question. It is of no use saying that everybody knows the Strawberry

* The best plants we ever knew were raised in flower saucers. The shallowness acted on them like the hard walk.—ED. C. G.

sinks into a sort of quiescent state every winter. What we want to know is, whether a decided rest is a physical condition of the plant's well-being, as to a perpetuation of the species. The Alpines—a distinct section of the strawberry family—studied alone, would at once decide an inexperienced student to conclude that for the high organization of the incipient blossom-bud a comparative rest, &c., were unimportant. The Alpines, however, may be termed annuals, and perfectly distinct in habit. Our opinion, however, is, from a consideration of the facts, that our ordinary Strawberries *do not* require a marked rest, at least, not in the same sense as we apply it to our ordinary deciduous trees; and our reason for tracing out this part of the subject is to point to the fact, that those who have cool frames or pits to spare, may doubtless plunge them in such structures in autumn—say by the end of September—and by coverings never suffer the temperature of the interior to attain the freezing point.

Now, it must be confessed, that these opinions may be considered slightly speculative for the present, but we should by no means object to put them in practice. We think, that to grow them extensively for market, brick pits would be the best economy; and the following is about the plan we should adopt. Pits about six feet wide, to hold six plants in a row, at about a foot apart; three rows reached from the front, and three from back. These pits to be about three feet above the ground level at back, and about one foot at front. To have a permanent bottom-heat provided, as in Hamilton's pine-system: a heat capable of modification, to meet varied circumstances, but having the capacity to reach 80° in the soil if needed, and a separate pipe, from a separate boiler, to warm the air of the pit at times, if required. Here we would at once plant out the well-ripened crowns, at about a foot apart, and as soon they were ripe, hurry them into market, pull up the plants, and instantly plant another lot, which might be in a somewhat advanced state, from other structures. By such means, we should hope to fruit nearly half-a-dozen batches of plants before the middle of May; and a man, with an acre of ground thus occupied in parallel lines, would furnish all our first-rate markets abundantly. But the business of such pits would not end here; they would produce thousands of Melons and Cucumbers after the Strawberries, until the following November. Such pits should have some night coverings; and if we had the management, we would keep whole lines of strong young plants in a nursery specially for the production of runners; every blossom should be plucked from them, and everything done which could add earliness and strength of constitution to the young runner.

These hints are for those whom they concern; we must alight from our hobby, and talk to small gardeners. "What condition does the Strawberry like, and what dislike?" was the digressive point. They like to be forced very gently; to be very close to the glass, especially a roof; to be carefully attended with water, and an atmosphere permanently charged with moisture. Who has not observed their beautiful exuberance during the heavy dews of a fine May,—every leaf laden with the glittering spangles? What they dislike is, of course, nearly the converse of all this; they dread a high night temperature, and, indeed, a high temperature of any kind; they never seem quite at home much beyond 60°, and, indeed, we would make 65° our maximum in early forcing, even with sunshine, sinking to 50° at night; they dislike being dry at root after the truss begins to rise; and they abhor insect enemies under whatever guise. If they are neglected in regard of either air-moisture or root-moisture, and high temperatures are sustained, the red spider speedily finds them out.

And now we must finish these somewhat unconnected observations with advising our beginners in this way to

mind the principles laid down. It matters not what their structures are called—pits, frames, greenhouses, what you will—the Strawberry cares nothing about structures; it is on those elementary conditions of light, atmospheric moisture, and the warmth they most affect, that success depends. Let it be remembered, that if the plants are not strong and ripe in the crown, the forcer must suffer his ardour to decrease in a *like* ratio; better be less ambitious—be content with ripe Strawberries in the end of March, instead of February.

R. ERRINGTON.

THE GENUS CEANOTHUS.

For the last two or three years I have had this family in my eye as fit subjects for the experimental garden of the cross-breeder; and now that I have been asked to write on the propagation and culture of one of the species (*C. rigidus*), it seems as if the opportunity had rather been thrown in my way, than that I went out of the path in quest of it; at all events, a tale about good subjects is never much out of season.

For many years the only *Ceanothus* known in our gardens was *CEANOTHUS AZUREUS*, still one of the best of the race where the climate suits it. I never saw but two plants of it managed so as to make the best of it in our climate, and one of them was the very handsomest plant in England at the time. I saw it in the most luxuriant growth, and clothed all over with its bright blue flowers, in long (much longer than usual) racemes from all the points of the shoots, and also from all the divisions (axillary) on the upper parts of all the young growth. I am not aware of a single hardy shrub in the country that is capable of so much improvement as *Ceanothus azureus*, and by treating it a few years at first in the way which I shall explain presently, it would stand our ordinary winters against a wall anywhere in which the Peach and Nectarine ripen.

It is a native of temperate regions in Mexico—not from the Cape, as is asserted in some books; and it is less hardy than any other of the species in cultivation. In the climate of London it is seldom much hurt by frost, when trained against a wall; and it flowers from August until stopped by frost. The flowers are borne by the young wood made the same season, like the grape vine; and, what is very singular, this habit is seldom made the most of, less so, indeed, than in any other plant. It is the custom, in most places, to give it protection in winter, but the young wood seldom escapes from injury, more or less; and the plant is not pruned until all danger from frost is over in the spring, when more of the young wood that has escaped the frost is nailed, or trained in, than is at all necessary; and the usual result is, that the flowers are not nearly so numerous nor so fine as they would be under a very different treatment.

Among all the plants that we train against walls, for their flowers, there is only one more which requires the same treatment as this, and that is the *Rosa microphylla*, or small-leaved Rose, from China. When either of them is first planted against a wall it ought to be headed down to near the surface of the ground, in October, for the first three years, at least, in order to get a sufficient number of strong healthy shoots from the bottom to form the skeleton of the future plant; these main shoots ought to be then trained in the fan-shape, like a peach-tree, with intervals between them as wide as are allowed to the main branches of a strong-growing pear tree, or say, not less than a foot from branch to branch. The same kind of pruning as they give to pear trees, until they fill up their allotted spaces, is the right way for this; that is, to cut back the young tops of the leaders to one-half or two-thirds of their length,

when duplicate leaders are wanted, and as the tree, or at least the young wood, is rather tender, this pruning ought to be done about the end of October, in order to get rid of as much young wood as possible, and so leave very little of it for the frost to play on.

Now, suppose a full-grown *Ceanothus* thus treated, it ought to look as much as possible, at this season, like one of those root-pruned pear trees about which Mr. Errington has given so many valuable directions; there are the spurs all the way up, on every main branch or leader, just as on the pear tree. But now, or from this time, the annual pruning of these spurs must go on exactly contrary to each other. The young wood on the spurs of this *Ceanothus*, and on the *Rosa microphylla*, must be cut as close as the knife can reach it, and that in October every year, and then the frost will have little or none to kill, even in the hardest winter. Next season, a whole thicket of young breast-wood will grow out from the close spurs; the more the better; but not a twig of it should be touched the whole season. Every year's growth ought to stand out from the wall, as wild as in nature, and as free. Then, and not till then, are the Blue *Ceanoth*, and the Small-leaved Rose, to be seen in their perfection of bloom, and the pruning in October will be more like cutting a bed of willows, or a field of corn, than anything else that I can compare it to. I have seen all this done for ten years in succession, and I am sure it is in accordance with the soundest principles in gardening.

I have a new scheme for growing this beautiful plant, of the success of which I am as certain as if I had seen it in practice for twice ten years; and with all the earnestness of a young convert, I recommend its immediate adoption. Any one having a couple of yards of garden ground may test the experiment. It is simply to manage it in all respects as you would a plant, a bed, or a row of the *Fuchsia gracilis*. First of all, make the bed as good as any bed was ever made; let one-half of it be of the nicest yellow or nut-brown loam that is to be had for love or money, quite fresh from the bank, or meadow, if possible, and with all the rough grass, roots and all, chopped up with it, the other half I would have of best turfy peat and half-rotten leaf mould, in such proportions as the compost-yard may point to: I am not particular to a shade, provided the loam, peat, and leaf mould, are the best of their respective kinds. Let this bed be two feet deep, and three or four inches above the general level of the surrounding grounds, and let the bottom be dry, or all will be lost. A border in front of a south wall would be a favourable situation for the first trial; open a trench a yard wide, and two feet deep, and fill it with the compost; then, about the end of April, plant a row up the middle, placing the plants two feet apart, and if they are in pots, shake off all the soil from the roots, and spread them out evenly, and so that the neck of the plant is a little deeper in the border than it was in the pot; then cut the plants to within six inches of the ground, and let them not want for water all that season. In October, cut all the young wood back to within an inch or so of the bottom, and put a covering of half-rotten dung all over the trench for the winter, and next year you may expect flowers in August, at any rate. Continue the same process year after year, and there cannot be a question about the thing answering in almost any part of the kingdom. The very same kind of treatment would do for all the *Daturas*, with a more safe covering in winter. The Coral tree (*Erythrina crista-galli*) would answer perfectly in a similar manner; but whether or not the rest of the *Ceanoths*, or any of them, would answer equally well, or at all, is more than I can affirm.

CEANOTHUS PALLIDUS, *alias* *INTERMEDIUS*.—This is an English seedling obtained from *C. azureus*, by Mr. Masters, of Canterbury, and, as it is said, by crossing it

with the pollen of *C. Americanus*. I have often examined this plant in flower, and were it not for the well-known respectability of our authority for the cross, I should be very much inclined to doubt the plant being a cross at all, but only a natural sport; be that as it may, all that I have said about *Azureus* will apply equally to this plant, excepting the colour of the flowers, which is paler, and not nearly so rich; but where are we to look for the exact tint of the flowers of *Azureus*, when the plant is growing under favourable conditions?

CEANOOTHUS AMERICANUS.—This plant is called the New Jersey Tea, in America, where they used the dried leaves as a substitute for Chinese tea during the war of independence. This is a dwarf bush, bearing white flowers from June to August, and casting its leaves in the autumn. It is rather a pretty shrub, but not to be compared with the above, nor with the Californian species, excepting *Cuneatus*, which is also a white-flowering one, and still less handsome than *Americanus*. Any good garden soil, on a dry bottom, will grow *Americanus*, which ripens seeds in the neighbourhood of London in favourable seasons.

Amateurs, who do not understand the right kind of cuttings, or the exact time when they are ready for use, find a great difficulty in striking cuttings of either of the above; and the best advice for them, is to get them from layers made at the end of spring: these seldom fail. It is difficult to convince amateurs that layers made of hard-wooded plants should have the slit, or tongue, made on the upper side of the shoot, because they see that it is made on the *under-side* of the clove and carnation, and other soft, pliable shoots.

The following is the way to make layers of hard-wooded plants—Stoop down opposite the bush, and take a shoot of the last growth in your left hand, the point of the shoot facing you; then at four or five inches from the point where there is a joint on the upper side, slip in your knife a little below the joint, draw the knife to you and through the centre of the joint, and on an inch or so towards yourself; now bend the top of the shoot gently away to the left, and the tongue or cut part will go to the right, and when the cut end is clear off the shoot it is ready for laying two inches deep in the ground; place a pinch of sand just under the cut, and fasten it down with a hooked peg; then cover and press the soil gently all round, particularly to the side of the layer next yourself, so as to keep the end well up. All this time, and until the whole is finished, you must not let the layer out of your hold for an instant; for if you do, snap it goes in a moment, and the off-end of it will give your eye such a scratch as you will remember till the next new moon, if worse luck does not finish the layering for that week. *Ceanothus Pitcheri*, *herbaceus*, *perennis*, *intermedius*, and *ovatus*, are all secondary names for *Americanus*, or slight variations of it, from seeds, which are not worth the trouble of keeping separate.

CEANOOTHUS DIVARICATUS (*thyrsiflorus*?).—This is the first of the Californian species that found its way to this country in a living state. It is from near Monterey, where it grows to the size of a small tree, and flowers there from May to November. It is perfectly hardy in the climate of London, and will grow in any good garden soil. Its way of close growth, and shining, dark green leaves, and its numerous bright blue flowers, render it altogether one of the most handsome evergreens we have. It may be propagated all the year round from cuttings of the young wood, which root as freely as those of *Verbena*, and it grows rapidly in good soil, so much so, that it is eminently fitted for making one of those standard evergreens which are so much admired in geometric lines or gardens. With a clear stem, six or seven feet high, and a large round head kept regular, we have nothing that could come near to

it in beauty. The small-leaved *Phillyrea*, as a standard, is our nearest plant to match it, or it might be allowed to spread into an open, loose-headed standard, or merely be allowed to form itself into a large bush. Whichever way it is grown, it requires five or six years good growth before it will flower much.

CEANOOTHUS PAPPILLOSUS.—This is another very handsome, large, evergreen bush, from the Mountains of Santa Cruz, in California, where Hartweg found it growing to the height of ten feet. It has small, blunt, dark green leaves, which are downy on the underside. The flowers are as bright a blue as those of *Azureus*, with a purple tinge. This plant is also readily increased from cuttings. Having only been introduced in 1848, we are not yet sure how much cold it will endure, or how far north it will flower with freedom. In the south of England it comes into flower about Midsummer, and holds on a long time.

CEANOOTHUS DENTATUS.—This is comparatively a dwarf species in its native country, near Monterey, in California. It is of less stature than *rigidus*, on the same ground, not rising above a yard high, where *rigidus* grows to four or five feet. This, also, was sent over by Hartweg to the Horticultural Society in 1848. All the plants from Monterey are hardy enough here, as far as our experience of them goes. In the south of England this bush flowers beautifully in May; the blossom is deep blue, in round heads, and very handsome. It comes from cuttings, like all the rest of the Californian species, very freely.

CEANOOTHUS VELUTINUS (Velvety-leaved).—The velvet is on the under side of the leaves; the upper side shines as if varnished. This is a white-flowering species, and handsomer than *cuneatus*, and the varieties of *Americanus*, all which are white-flowering ones. It was introduced by the Horticultural Society from the sources of the Oregon, and is quite hardy, growing to a large-sized bush from five to ten feet high, and is easily increased. For a small garden this is the only white *Ceanothus* I would recommend. *C. Collianus*, another white one, but a dwarf plant, is very nearly related to *velutinus*; and *C. cuneatus*, one of the new ones, is white, and really not worth growing.

CEANOOTHUS VERRUCOSUS (Warted on the Stems).—This is also one of Hartweg's new ones, and one of the very best of them, which will be a match for *divaricatus* soon; the habit is even stronger than in *divaricatus*. It would also make a handsome standard if it were trained so, but the stiff way of growth will hardly admit of being formed into such a regular shape as *divaricatus*. The flowers are light blue, and are produced in immense quantities from all the little side-shoots, forming great balls, or rather corymbs, along the whole length of the main branches. This is the most suitable of all the blue ones for the north of Scotland: strong, stiff, regardless of cold, and even soil, and flowering in the height of summer. It was first called *integerrimus*.

D. BEATON.

WINTER-BLOOMING, HARDY, GREENHOUSE PLANTS.

HABROTHAMNUS ELEGANS.—I think I first saw this plant growing against a pillar in the conservatory at the Regent's Park. Though it was then in early summer it was a beautiful object, with its large bunches of carmine tubular flowers depending from the points and sides of the young shoots. Many a visitor joined me in gazing at it, and from that day to this there have been repeated inquiries as to its culture. All the family introduced are natives of Mexico; belong to the Nightshade order; and in the shape of the flowers, and the mode of growth, resemble their near neighbours

the *Cestrums*, some of which, such as *C. aurantiacum*, though usually grown in a stove, yet, under proper treatment, would make a nice companion for our present favourite in a moderately warm conservatory. The name of the genus is appropriate, signifying "gay shrub;" and so far as the present species is concerned it may well be termed "elegant." First impressions are queer things to deal with, though we should admit only a tenth of what the ladies say about them. Their general influence is to stereotype an idea; and even should the opinions formed be based on nonentities, or warped by prejudice, it requires accumulated reasons and proofs to dissipate the first-formed notions. This is so far my case at present. No sooner is this plant mentioned, than, without the *presto* of the wizard, the cap of Fortunatus, or the passes of the mesmerist, by some means or other, I feel myself straining my mental vision on the identical column in the conservatory of the Botanic Gardens. It is true, the plant grows very well in a pot, and, however grown, it is an interesting object; but were I asked how to produce the finest effect at the least possible amount of labour, I should decidedly say, turn the plant out into a border when one yard in height, and against a pillar, where it could have air and light all round. Sandy loam, and plenty of water, with proper drainage, will grow it well; but it will be advisable to give it a little peat when first turned out. Everything must be done at first to encourage growth; but in the second season, the stronger shoots should be shortened to produce plenty of weaker ones, and which will be ripened before winter. After that, little pruning, besides pinching a strong shoot, will be required. The shoots, except the leading ones, will soon acquire a pendulous position; and these, if well-ripened, will have large bunches of flowers at their points first; and as these are cut off others will take their place farther back on the shoot; and this continuous nipping-off the wood with the flowers will be the most of the pruning required. By this treatment, a plant has never been without bloom for a twelve-month; but during the whole of the winter it is plentifully supplied. Thus managed, few things will beat it, or look more interesting in a greenhouse. It is also useful for cut flowers, where people can be satisfied with a small piece of the plant to support them. Our bouquet-makers, who wire or gum each separate flower, would say nothing at all about the shortness of the handle. For this purpose, it is something like the Scotch kale in the kitchen-garden—a regular "cut and come again," as, without the removing of the terminal bunch of flowers, many of the incipient bunches at the axils of the leaves farther back will not have stimulus enough to cause them to expand.

Many, however, who have not a pillar to spare, might wish to grow it in a pot, after what some may consider this too flaming a recommendation. I will just glance, therefore, at its general management. *Propagation*.—Firm, short side-shoots, inserted in sandy soil, under a bell-glass, and in a little bottom-heat, strike freely. If you inserted the cuttings this or the following month, potted them directly they were rooted, kept them close in a hotbed at first, and more open afterwards, shifted as fast as they required it, and hardened off in the autumn, you might have small blooming plants the first winter. Some orderly folk would object to giving such hardy plants such hotbed treatment; and, though it is by no means necessary, yet most of these largish-leaved American plants enjoy such treatment amazingly, and, if properly exposed and hardened off in autumn, will bloom none the worse in consequence. If you neither strike early, nor give more encouragement than a cold frame in summer, you must not expect the plant to bloom until the second winter, under even good general treatment.

Supposing, then, that you have kept the plant in a cold pit or a greenhouse in winter, it should be examined by April, and placed either in the greenhouse or pit, so as to encourage growth by closeness and warmth; the size of the plant will determine the shifts to be given. You will not do much good with a pot less than twelve inches diameter, and into that the plant should be got by the middle of June at farthest. The soil should consist of peat and loam at first, but as you shift the loam must be increased; and then, if after all there should seem to be a lack of vigour, top-dress with old cow-dung and charcoal, and give weak manure waterings. The plant will never naturally make a bush; the shoots are lanky, and half-inclined to twist, one stake must therefore be used as a support; but when hasped to this stake, the strongest shoots being previously stopped, the points must be fixed in a pendant position to a ring of wire round the rim of the pot. By this mode persevered in, something of a conical shape will be secured, and by a less obtrusive method than a trellis or a forest of sticks; besides, the direction given to the shoots will secure their ripening, and consequent blooming freely. Everything should be done by a close, moist atmosphere, to encourage growth, until August approaches, then more air should be given, until, by the middle of September, the plants are fully exposed. In October they should be defended from heavy rains, and towards the end of it safely housed. I have never tried it against a wall; I have no doubt it would do well protected by glass. In pots, besides fresh soil, the chief trouble would be in the first year's growth, as after being established the plant would have the whole summer for growth and ripening. In pruning, bear in mind that bloom is chiefly produced on young shoots coming from last year's wood. The bending recommended encourages every bud to break.

HABROTHAMNUS FASCICULATUS.—I cannot boast of my success with this in a pot, partly, I believe, from want of proper attention. I have seen it very fair against a wall, and have no doubt it would be a desirable plant for a glass-case before the severity of winter sets in. I mention it here for the purpose of stating, that a gardener from Yorkshire told me, not long ago, that he had seen it there trained up a conservatory column, and almost, if not quite, as fine as the plant of *elegans* he was then examining. Everything that will bloom freely in a greenhouse in winter, and cost little trouble, should at least be tried. Among others of the genus, of which I know but little, there is *H. cyaneus*, of which I know nothing; but if its habit were good, the blue flowers it is represented to have would render it a great acquisition. I may add here, as a note, that the same gentleman, when looking upon a blaze of *Poinsettia pulcherrima*, told me that they grew the white variety considerably in the north. Now I do not think we have got that at all common in the south; and though, for effect, it would bear no comparison with the dazzling crimson, yet the beauty might both be enhanced and mellowed by blending and contrast.

VERONICA ANDERSONII.—This is the most beautiful shrub of the family. The habit of the plant is compact and graceful, and, according as it is treated, it will continue to yield its pretty spikes during the autumn, and winter, and spring. In fact, by regulating the time of *stopping*, and then maturing the young growth, flowers might be commanded for the most of the year. To bloom in winter, cuttings of firm young wood should be inserted in sand, under a bell-glass, before Midsummer, potted off in sandy loam and peat, kept in a cold frame, freely exposed in autumn, and given an airy position in winter in a greenhouse or cold pit, applying no more water than it absolutely wants. With such a plant, or a young one purchased, begin to push growth along in March or April, by giving the plants a closish, warmish

position; stop the shoots to increase their number, and continue nipping the strongest until June; hasping the strongest to the rim of the pot will be nearly all the training that will be required. Pot when necessary, until, by the middle of June, you give the last shift into an eight or ten-inch pot, using plenty of drainage, and a little charcoal and broken bricks to keep the soil open. From May, until the middle of July, a cold pit, where the plant can be kept rather close to encourage young shoots, will be the place for it. After then, air must be more freely communicated, until full exposure is given to the top of the plant in August. This will ripen the young shoots, and cause flower-buds to form freely. By the middle of October it will be advisable to remove the plant under protection; for though the plant itself is not easily injured, the incipient flower-spikes might be nipped by any sudden extreme.

VERONICA SPECIOSA.—Few shrubs are more graceful-looking than this, but the flowers, though interesting, bear no comparison to the above. It is one of the things I got tired of. Its free growth, and large size in a couple of years, demands so much space; though even as an evergreen bush it is interesting. It has been tried out of doors, and against walls, with more or less success. A glass-case would seem to be the place for it, the protection being removed in summer. Treated as above detailed for *Andersonii*, it will bloom in winter and spring in a greenhouse; but there should be no stopping the shoots after the middle of May, or they will not bloom early enough.

LITHOSPERMUM ROSMARINIFOLIUM.—A pretty, dwarf, blue-flowering, hardy shrub, found plentifully about Naples and the Grecian Archipelago. It deserves a place among hardy greenhouse plants in winter, as wet and frost spoil the flowers when out-of-doors. Plunged out-of-doors it might be introduced in November. It is easily propagated, and as easily grown. In beauty it is superior to more tender species. It deserves a conservative wall, though hardy.

AZARA INTEGRIFOLIA.—An interesting evergreen shrub that produces its bunches of flowers out-of-doors in winter in the south of the island, and, I have been told, in many parts of Ireland. I have never seen it in bloom, in such circumstances, north of London. Protected from wet, this and *A. dentata* will flourish as evergreens against a wall. Great quantities were raised of it by Mr. Knight, of Chelsea, from Chilian seeds, some twenty years ago. Compact bushes would ornament a hardy greenhouse in winter. Cuttings of firm, young shoots strike, *but slowly*, under a bell-glass or hand-light. Loam and peat will suit it.

SELAGO DISTANS.—There is nothing very striking in this small, white-flowering plant; but it is one of the newest of a family not particularly distinguished for blazing beauty. I introduce it here because it flowers so freely in winter and spring. Like the rest of its neighbours it comes from the Cape of Good Hope. Many of the species thrive nicely when planted out in summer. Cuttings of firm, stubby, young shoots, if struck under a bell-glass in spring, will enable you to have nice little potted-off plants before the end of autumn. These, kept in an airy, dry place in winter, stopped and shifted in spring, grown in a closish cold pit in the beginning of summer, and more air and complete exposure afterwards, will furnish nice little plants for winter-blooming. Sandy loam, and a little peat or decayed leaf mould will grow it.

This paper may be considered as a supplement to those on hardier greenhouse plants in former volumes. An average temperature at night, ranging from 37° to 45°, will suit them.

R. FISH.

THE AURICULA.

(Continued from page 264.)

SUMMER TREATMENT.—In dividing this subject into heads, I ought to have written spring and summer treatment, and autumn and winter treatment, for a different management is required at all the four seasons. The spring for blooming; the summer for growing; the autumn and winter months may be considered as requiring a protective treatment. In accordance with this arrangement, I shall, on this occasion, commence with *spring culture*. This commences about the middle of February; the plants should then be healthy, have green, broad foliage, with the soil moderately dry. Some fine day, about that time, have all the plants brought into the shed on the potting bench, and while they are there let the frame and glass be thoroughly cleansed. If they stand on a bed of coal ashes let it be raked over, clearing away all moss and weeds, and apply a thin layer of clean, dry, coal ashes, or even sawdust. If they stand on a stage inside the frame (which is by far the best method, because they are then less liable to damp and mildew), let it also be well scrubbed; let the glass lights be placed against a wall to thoroughly dry; look well inside and outside for slugs and snails, and destroy them. While this cleaning is being done, let a careful hand examine the plants, clear away all decaying leaves, and a portion of the top soil; and if the pots have become mossy or dirty on the outside, let them be clean washed, without wetting the soil. When this operation is complete, the pots first done will be dry enough to handle again. Have some rich compost, in a moderately dry state, and put a layer of it in each pot. This is what is called, in the florists' language, a top-dressing. The compost for this should be richer than the one used for potting, that is, it should have a larger proportion of well-decomposed and sweetened manure in it. Finish this top-dressing neatly, pressing it gently round the neck of each plant; then, if any have been observed to be rather dry, give such a gentle watering, and let them stand on the bench till the superfluous water has drained away. The plants will then look tidy and fresh, and if they could speak would thank the operator for his pains. Replace them in the frame; cover them up effectually, if there is the least appearance of frost, for then they will be very susceptible and impatient of cold. Give air early in the morning if the weather will permit, and let out the damp that may have accumulated through the night, after such a thorough cleaning. Though this spring-dressing will be better done so early in the year, yet, if the weather is severe and unpropitious, it may be put off till the first week in March, but by no means later, for the additional stimulant in the new compost is intended to assist the plants to throw up stronger and finer blooms, and if it is delayed after that time the effect will not take place. After this the usual routine of culture should be diligently followed. The giving of air on all favourable occasions is the most important point at this season. Whenever the day will permit, expose them fully to the sun-beams; and other soft, humid days, give air by propping up the lights behind. This strengthens the plants, and encourages them to send up strong flower-stems. The giving of a due supply of water is also of great moment now. They should neither be wet nor dry, and when water is given, it should be in such quantities as to wet the whole of the soil in each pot. Great discrimination must be exercised on this point, and the quantity of water given to each plant should be in proportion to the state of the soil. If dry, give plenty; if moderately so, give less; and if wet, give none at all, but omit such plants till the next time, or till they absolutely require it. The watering-pot should be a small one, with a

small, rather long spout, tapering to the end. Such a pot will give the operator power over the water so as exactly to suit the quantity each plant requires. By no means use a nose at this time of the year, but water the soil only, not wetting the leaves in the least; and, above all things, take care to use water with the chill taken off, not exactly warm water, nor yet ice cold, either extreme would be injurious.

The next important item in spring culture is to keep the plants as nearly as possible at an equal temperature. Actual frost would now cripple the blooms, and too much heat would draw them up weak, and cause them to flower prematurely. To prevent these extremes, cover them up securely every night. Straw mats, with a common garden mat thrown over them, are the most effectual protection I have ever met with; any labourer can make these straw mats during long evenings or wet days. They are best made of wheat-straw, and if put by when done with in a dry state will last a long time; three seasons at least. Too much heat may be easily avoided, by giving air and shading when the sun becomes too powerful. As the flower-stems advance the season will be advancing also, and then the covering at night may be reduced, but this must be carefully done, and the weather watched almost hourly, for often in April we have frosty nights, and once, by a too great security, or, I had almost said, carelessness, if the plants are allowed to become frost-nipped, the bloom for that season will be spoiled. It is better, therefore, to err on the safe side, and keep the night covering on a little longer, till the blooms are quite safe. The last week in April, or the first week in May, they should be in perfect bloom, and will require shading daily whenever the sun shines. Some florists remove them then into a shady place, and place them under hand-glasses standing upon a brick at each corner of the hand-light. This method certainly prolongs and preserves the bloom, but I do not approve of it generally; because the flowers cannot be so easily seen or shown as in a frame or on a stage.

T. APPLEBY.

(To be continued.)

CONIFERÆ.

(Continued from page 245.)

PICEA.—The Coniferæ classed by Loudon under this name are commonly called Silver Firs, because of the silvery-white colour of the underside of the leaves. Many of them form stately evergreen trees, and will grow in and thrive best in low, moist situations much better than the Spruce Firs, which often in such a soil become diseased and perish. This peculiarity renders the genus *Picea* valuable as an ornamental tree in such districts as the lowlands of Lincolnshire and Cambridge-shire, where the greater part of Coniferæ would look starved and miserable, and ultimately die before they had reached to anything like timber.

PICEA AJONENSIS (Ajona Silver Fir).—Though a native of Siberia, very little is known of this tree. It is said to grow to a great size.

PICEA AMABILIS (Lovely Silver Fir).—This fine tree, from California, is so extremely rare that our knowledge of its habits and uses are extremely limited.

PICEA BALSAMEA (Balm of Gilead Fir).—Native of Canada. Of all the Silver Firs this is the best known. It is highly ornamental, though not a tree of the first magnitude, seldom exceeding fifty feet high. It is less liable to disease than any other of its tribe, and grows very rapidly, especially in moist ground. From it the Canadians extract their famous balsam, which they call "Balm of Gilead," hence its specific name. There are two varieties of this really beautiful and perfectly hardy tree, one is named *Picea balsamea prostrata*, and is a

low bush, of a rather drooping habit, the other has the leaves slightly variegated, and is the *Picea balsamea foliis variegatis* of gardens.

PICEA CEPHALONICA (Cephalonian Silver Fir).—A native, as its specific name imports, of Cephalonia, on the Black Mountain, and is, therefore, perfectly hardy. It is a tree of second magnitude, rising to the height of sixty feet, with excellent timber, remarkable for its hardness and durability. The cones are erect, long, and slender; leaves sharp-pointed, with winged stalks.

PICEA FRASERI (Fraser's Silver Fir).—There is a considerable resemblance between this and the last-named species; the difference consisting in the leaves being more thinly placed upon the branches, and not being so bristly. It is very handsome; but being a native of Carolina is not so hardy, neither does it grow so tall, its average height being from 30 to 40 feet. The variety *Picea Fraseri Hudsonia* is a low bush, and is quite hardy, as it is native of the cold regions of Hudson's Bay.

PICEA GRANDIS (Large Californian Silver Fir).—This is one of the nobles of California, growing, as the late Mr. Douglas relates, to the height of 200 feet. The timber is of excellent quality. The finest specimen, probably, in England, is growing in the grounds at Dropmore. I had the pleasure of seeing it there last summer, and it was nearly nine feet high, and growing very rapidly. The large handsome foliage rendered it very ornamental and conspicuous, even amongst the fine plants of this tribe so profusely planted there.

PICEA NOBILIS (Noble Silver Fir).—Native of the same country as the preceding, and something similar to it. The only difference is, the leaves are of a silvery milky-green hue on both sides, and are a trifle shorter; by these it may be easily distinguished from its majestic congener. There is a fine specimen, growing near to the one mentioned above, of *Picea nobilis* in the same place (Lady Grenville's) and of the same height. The botanical difference is, however, chiefly in the cones, which, in this species, are very large, and covered with large reflexed bracts. This species is more common, because it strikes readily from cuttings, which soon form a leading shoot, and become, after the third or fourth year, regular-formed, handsome plants.

PICEA NORDMANNIANA (Mr. Nordman's Silver Fir).—A large tree, native of the north of Asia, on a high mountain. It is a handsome species, and believed to be perfectly hardy. The cones are short and broad, and reflexed at the apex.

PICEA PECTINATA (Comb-like-leaved Silver Fir).—This is our common Silver Fir. It is widely distributed, being found in central Europe and the west and north of Asia. It is well known, and therefore needs little description. There are some extra-fine trees, nearly a 100 feet high, in the park at Strathfieldsaye, the seat of the late "Iron Duke." The soil and climate there is moist—so much so, that most of the trees, both of the plantations and gardens, are hoary with lichens. If proof were needed, this would be sufficient to show that Silver Firs love a low, moist situation.

PICEA PICHTA (Pitch Silver Fir).—A low tree, native of the Altai Mountains.

PICEA PINSAPO (Pinsapo Silver Fir).—A very handsome, slow-growing, regular-formed tree, now pretty common. The great distinction of this beautiful tree consists in its leaves being perfectly round, and placed equally on every side of the branches. It is a native of Spain, where, when of a great age, it reaches the height of seventy feet. No collection, however small, ought to be without one or two of this beautiful species.

PICEA PINDROW (Pindrow or Tooth-leaved Silver Fir).—Like *P. Webbiana*, but the leaves are longer, and not so silvery-white on the under side.

PICEA RELIGIOSA (Sacred Mexican Silver Fir).—This

is a large, lofty tree, often attaining, in Mexico, the astonishing altitude of 150 feet. In this country it is, unfortunately, too tender to bear the open air, but I have heard there is a specimen in Devonshire that has stood out three winters uninjured.

PICEA WEBBIANA (Mr. Webb's Purple-coned Silver Fir).—In giving lately an account of the *Coniferæ* at the Rev. —Thicken's, near Coventry, I described a noble specimen of this rather tender species—tender because it is so easily excited to grow in the spring that the young shoots are frequently destroyed. The tree is hardy enough through the winter, but suffers from the late frosts after it has begun to grow. Probably, if it was planted on the north side of a hill it would not be excited into growth till the spring frosts had passed over. In the instance above referred to the specimen had apparently never been injured. It is an Asiatic species, growing on the mountains of Nepaul, where it reaches ninety feet high. It is exceedingly ornamental; the leaves are broad, and arranged in two rows, and of a pure silvery-whiteness on the under side. There is a large specimen in the Pinetum belonging to that great patron of gardening, Mrs. Lawrence, at Ealing Park.

T. APPELBY.

(To be continued.)

FORCING OPERATIONS PROPER AT THE SEASON.

THE commencement of a new year always brings with it hopes of something being likely to improve. The very fact of the days lengthening, and less probability of meeting with so many dull and damp ones, helps materially to cheer on the enthusiastic cultivator, to whom the "dark days before Christmas" have a more or less depressive feeling. But as that ominous period is past, let us also hope that the deluging rains which ushered them in, and kept them company, are in a measure passed also; and with the opening year let us hope to have fewer of those drenching rains which have so much retarded out-door operations; at all events, the increasing length of days is somewhat inspiring, as by that the hopes of better times seem daily more near at hand; nevertheless, the same vigilance as hitherto is necessary to protect the various tender things from the effects of damp, while it is likely to be more wanted to protect them from cold; in fact, the past autumn has been unusually mild; many tender plants, capable of resisting damp, were unscathed after Christmas; that a check will be given is both probable and even wished for, as it rarely happens for a mild wet winter to be followed by a productive season; but, without attempting to foretell what may occur, it more becomes us to take the necessary steps to make the most of the present. Especial care must, therefore, be taken of all delicate seedlings struggling against the absence of sunshine, and the presence of undue moisture. The past autumn has been more than usually fatal to *Lettuce* and *Cauliflower* plants sown late and only temporarily protected; as where the vigorous character of the seed, accompanied with other favourable circumstances, was unable to support the young plant against the decaying effects of so much humidity, it speedily fell a prey to shanking; and many beds of what ought to be healthy seedling plants, present only a few scattered patches here and there—the remnants of a pestilence which the skill of the practitioner strove in vain to arrest. Such, however, as do exist, must be carefully looked after, as they cannot well be replaced without the assistance of heat and glass protection, which, for the next few months, will be less plentiful than heretofore.

The beginning of a new year is also a favourable time for the amateur of humble means commencing forcing

operations with the *Cucumber* and *Melon*; and, notwithstanding the improved and daily increasing demands there is on hot-water as an agent of heat used in the production of these fruits, there are many good old-fashioned dung frames yet to be found; and fruit so grown very often competes successfully with that grown in the more modern-heated structure in which pipes and tanks of every variety of make convey the heating power. This competition is, however, more equal where the productions are not wanted very early, as the dung-bed, however congenial a medium for supporting healthy vegetation, is not vested with the power to maintain it against the destroying influence of a too wet atmosphere and a sunless sky. For very early work it is therefore advisable to have recourse to fire-heat in some shape or other; and the same may be said of very late forcing; or, in more plain language, where it is desired to have a crop of melons ripen well in November, fire-heat must be applied rather briskly, otherwise that amount of warmth necessary to insure flavour cannot be furnished by fermenting matter alone, without also carrying with it that moisture which is a preventive to the quality wanted.

This late forcing must not be confounded with the retarding process, whereby an article, which nature intended to perfect itself at a fixed time, should, by some process used, be prevented from coming into use at that time, but kept back, and allowed to come forward at a later period; this course, as every one knows, will not do for melons; disease and disaster is sure to follow such a plan. A plant enjoying the sunny climes of the east for a very few weeks, cannot be expected to accommodate itself to the cheerless atmosphere of an English autumn, without the assistance which art and science suggest as being the nearest approach we can command to the condition which it has lost; and yet how far that falls short, may be easily comprehended by any one who has studied the climate of those countries where it is grown naturally, with our murky atmosphere even in summer, while in autumn the contrast must be still greater. But this is a digression; my purpose being more to give some hints as to early spring work; and in this we have a young plant to act upon; or rather, we have young ones to rear, and not old ones to keep in health. These duties differ so much, that we will, in the first instance, treat of the raising of young plants; and, at a future time, offer a few remarks on the preservation of old ones; and, supposing that good stable dung is to be had, and a frame or two at liberty, it will be proper, in the first instance, to throw up, mix, and turn the dung several times, to rectify that unruly heat it would otherwise attain if left unprepared; besides which, those impure gases, of whose names most gardeners are ignorant (but of whose presence they can form a shrewd guess by the rankness of the smell), are thereby driven off; and the moderate heat that is left is cleansed of that offensive effluvia, and becomes what, in gardening phrase, is called "sweet." This congenial warmth, when accompanied by a fair share of sunshine, is, perhaps, the most agreeable of any for plants enjoying; as with it a degree of vigour is infused, which we think can hardly be imparted by the united power of fire and water, however well they may be managed.

This mode of heating, the most "time-honoured" of any, has, nevertheless, been made the subject of many novel inventions—some trying to make it act without its moisture being brought to bear on the plants, by compelling it to heat some stratum, which, acting as a conductor, only allowed the finer particles to pass through. This latter mode is exemplified in those pits or structures which are worked solely by linings, and some of them are very useful in their way, serving the purpose intended admirably. "Mills's Pit" is heated

entirely by dung linings, and few cucumber growers have attained a greater degree of distinction than he has; but since the easy application of hot-water, few pits are built with the many internal contrivances necessary there without having hot-water added also. But there are many make-shifts which answer the purpose equally well; a pile of rough timber, laid as open as possible, with the box-frame placed on the top, and surrounded with linings, forms a very good hotbed, and one in which many things may be grown as well as on the best-contrived structure to which fire-heat is applied. This, of course, depends on the attention paid to lining, and other things; but for very early forcing, with only dung as a heating material, I would certainly advise the frame to be raised in such a manner. A few rough blocks, placed in such a way as to give scope for applying the dung on all sides, and partially underneath as well, which is done by having the bottom of the pile more narrow than the top, taking care, however, that it is sufficiently steady not to topple over, and, as I have said, as open as possible, because it is those interstices which form the chambers serving as reservoirs of heat; a firm material may be at top, and finally the mould on which the plants are expected to grow. The difficulties of this plan is obtaining a sufficient amount of atmospheric heat, after the bed is covered over a fair depth with soil; but that is overcome by applying brisk linings, and keeping some places inside comparatively thin of soil, to allow the heated air to pass through without losing much of its warmth on its journey. Another point must be attended to, which is, never to have the pile of open work too high, because the linings must always be shewing above, otherwise the heat, instead of penetrating the mass of earth, &c., as required, would escape by the vacancy between the bottom of the dung-box and top of the lining. Thatched hurdles, or some other shelter, will be wanted to prevent drying winds cooling the dung linings too much. This attention, however, does not extend so far as to present any formidable difficulties; and as dung may be used fresh from the yard, without any preparation whatever, it becomes a matter of labour only, and even this is not so much more than that required for the formation of the ordinary dung-bed, and maintaining it in its proper state of heat, and at a time when it can derive but little or none from the atmosphere. But I will return to this subject again. In the mean time, I advise the amateur to look around and see what can be had for this structure amongst the things he has at command; and many makeshifts serve a purpose like this equally as well as the most perfectly-made pit erected by mechanical skill, directed by scientific principles; but, as in many other things, the secret of success lies in the due attention to many minor matters.

JOHN ROBSON.

A FAULT AMONG US.

By the Authoress of "*My Flowers*," &c.

It appears to me that there is "utterly a fault" among us. I do not know whether out-door relief in every Union is managed in the same way, but in *one*, I can truly say, "widows are neglected in the weekly ministrations." There appears to be very great cruelty in the way this class of persons are treated by the poor laws; they are most particularly regarded by God's law, and He has recommended them specially to the protection of man; but in the administration of the poor law, in at least *one* Union, there is, it seems to me, "utterly a fault."

It is said in the Word of God, by the Apostle Paul, in regard to his not wishing to be burdensome to the Corinthians—"For the children ought not to lay up for the parents, but the parents for the children." Now the Union, at least *one* Union, throws the widow entirely upon her children for support, and denies her relief at all, or only

partial relief, where her children are grown up, and able to work for their bread. Surely this is *cruel*. Can anything be more distressing to a mother, than to be dependant upon her children; to feel that every mouthful she eats is taken from them, and to have nothing of her own, but to be compelled to *ask* from her own offspring for every little article she wants? Which of the framers of such a law would himself stand, or leave his widow to stand, in such a painful position? I repeat, there is utterly a fault amongst us.

Thomas Edwards and his wife were rather above the common lot of labourers. He had a horse and cart, and gained his living in various out-door ways. He had a piece of allotment ground, too, and got on comfortably. He was not a man of much loveliness of character certainly; he was greatly given to drink, although not what is generally called a drunkard; and his wife had by no means a light burden to carry on her pilgrimage with him; but she was a steady, light-thinking, hard-working creature, and brought her family up well and respectably. They were never running in the streets, but kept at home, taught to be clean, honest, and hard-working, and whatever was shown them of good, was by her precept and example. In time they all married. One daughter lived in the next cottage, the other settled in London, and the son took a coachman's place, and married in London too. As Edwards advanced in life, he was subject to severe attacks of illness, which often laid him by. At length the complaint from which he suffered became confirmed, and his powers gradually weakened. He worked when he ought not to have worked, because he had only his own exertions to depend upon, but he used, when he could, to send his little grandson with the cart, or got some other man to go for him. Poor Phœbe looked anxious and woe-begone; she had at all times a troubled look—and well she might—but now she saw her husband breaking-up, and expenses coming upon her, and whenever she did smile, it was a very watery one indeed.

At last Edwards became so ill that it was thought desirable to get him into a London Hospital as a last hope. There was a possibility of an operation prolonging his life; in the language of the world, it was his only chance, and he was accordingly removed to town. Poor Phœbe walked about her cottage like a ghost when her husband was gone. Joy had long departed from her face, but now many cares and sorrows were painted there, and the thought of the agony Thomas must suffer distracted her, and she fancied every day might be the one chosen for the last chance. Her good daughter, Sarah, was her prop and stay; and Bill, her son-in-law, rose up and treated her like his real mother. Friends called to see and cheer her, and she heard tolerable accounts of Thomas from their son, who was able to go to him, his master being out of town. A few weeks, which felt like years to Phœbe, passed in this way. Hope upheld her; but she had had no letter for some days, and began to feel more than usually anxious.

One night, about nine o'clock, a tap at the door was heard, and in walked her son from London. He came to take her to the death-bed of her husband. The operation was over; it had promised well, but symptoms suddenly came on that baffled all skill, and Phœbe must start by the first train in the morning. No one can tell how she got through the night, or her journey, but she reached London too late; at the very hour she stepped into the train, Thomas breathed his last.

Phœbe was very ill for a long time after her return. She could neither sleep nor eat. The funeral expenses lay heavily upon her; the horse and cart was a burden upon her mind; she had no husband to lean upon, broken reed as *he* had been; and her futurity was all misty before her. She, however, was brought to look to the Strong for strength; she was greatly supported under the load of her difficulties; her friends were interested for her, and her daughter and son-in-law the kindest of the kind.

In the course of a little time she sold her cart and horse, and crop of barley; paid her poor husband's funeral account, her rent, and what other little things she owed, and took up her abode in her daughter's house. When she could say, with truth, that she had *nothing*, she went humbly to the Board of Guardians to ask for relief. She was strictly questioned, of course, but was told she could work in the fields for her bread. This went to her heart. She had

brought up a family without once burdening the parish. She was now advanced in life, broken in health, and quite unfit for out-door labour, to which she had never been used. But there was no appeal. She had children—they must support her. Her children were all scarcely able to support their own large families, and she said so; but there was nothing to be done. A loaf and a shilling a-week was granted while she was on the doctor's hands; but when she no longer was sick that relief was to cease, and poor Phœbe was to be thrown upon those who have large families, and barely enough for themselves. Is there not utterly a fault among us?

Three or four other cases of this kind have passed under my notice. One of the widows is the mother of nine sons. They are as kind as they can be to her, but still, like Phœbe Edwards, she is a painful burden to them, and every parent must feel it bitter.

Phœbe is beginning to look cheerful, nevertheless. She has the worldly comfort of being perfectly free from debt, and that some of my readers can, I dare say, fully enter into. She has, moreover, a good hope through "grace," and that is a wondrous sweetener of the ills of life. She speaks with energy of the blessings of adversity to her soul, and the help and strength she has found in Him in whom she trusts. Her eye kindles as she speaks, and when she smiles, it is a sunny smile, and not a watery one. Still, she is penniless; and although her child and son-in-law work for her, and make her welcome, she is but a pauper in their house, and she knows that every bit of food she eats is taken from the mouths of the children.

Blessed are those children who "honour" their parents as Sarah does! and blessed are the sons-in-law who rise up like Bill to succour and protect the widow! Blessed is the widow who trusts in the Lord, and cheerfully submits to His Holy Will. She will find the arm of the Lord is not shortened, but mighty to save. Still there is utterly a fault among us in this matter, for surely widows are special objects of consideration and care to all! If we profess Christianity, if we consent to take the Bible as our rule of faith and practice, the widow should be honoured and sustained, and shielded from want, in our congregations. But as it is, at least in *some* places, I humbly venture to submit to my readers, that the blessing of God is not regarded, nor can be expected, for there is utterly a fault among us in this thing.

BRAHMA POOTRA FOWLS.

IN a recent valuable contribution to THE COTTAGE GARDENER, in which the "vexed question" of the respective merits of the Shanghae, Spanish, and Dorking fowls seems to be discussed with admirable judgment and impartiality, an extract is introduced from a Canadian paper, wherein mention is made of two or three breeds of fowls hitherto unknown in this country, and in reference to which new breeds, your contributor (who signs himself "Cochin") expresses a wish for information. Perhaps the following particulars respecting one of them, "Brahma Pootra" fowls (taken from the "Northern Farmer," published in Oneida county, U. S.), will be acceptable to him, and to the generality of your readers, who are interested in kindred subjects; the more so, as they will, I believe, have an opportunity, at the approaching Metropolitan Show, of seeing a fine young pair of birds of this breed, belonging to Mrs. Hosier Williams, of Eaton Mascott, near Shrewsbury, to whom they were sent by Dr. Bennett, of New Hampshire, U. S., a name known, probably, to many of your readers, as the author of an excellent American book on poultry. Before giving the extracts from the "Northern Farmer," I may observe, that this breed appears to have been imported into America only within the last two or three years (having been brought by some sailors from a district on the great river in India, from which they derived their name), and that the American fanciers are as yet divided in opinion as to whether they are entitled to be considered a distinct breed, or only a superior variety of the Gray Shanghae, or, as some think, the Chittagong breed; some maintaining that the breeds are identical; others, with Dr. Bennett at their head, affirming their conviction that, even

apart from the consideration of the widely-separated localities in which the respective breeds have their origin, they present sufficiently well-marked characteristics and points of diversity to entitle each to be considered a distinct breed. Whatever truth there may be in these opinions, certain it is, that there is a rage among transatlantic amateurs for what are supposed to be *real* Brahma Pootras, which rank highest of all the large breeds, in the estimation of those who would seem to have had the best opportunities of judging of their real merits. Indeed, the mania there for the best varieties seems just now as prevalent, and quite as fierce, as with our amateurs for the choicest breeds in this country. And a pleasant jest of the facetious editor of the "Northern Farmer" would seem to point to the inference, that the prices realised for them is not less fictitious than those frequently obtained with us for the most approved specimens of Buff Shanghaes. After giving a few instances of the sums at which good specimens of Brahma Pootras had been sold (seventy-five dollars per pair for grown birds, and sixty-five dollars for chickens), he adds—"This will do, we think. By the way, if any one has a good snug *farm* that he will dispose of for a pair of these fowls, we shall be disposed to trade, if application be made soon!"

The following is a description of this breed, as given by Dr. Bennett, in a communication to the "Northern Farmer":—

"The cock is mostly white, with the neck hackles pencilled with black; the rump hackles of a gold or yellow colour; the tail black, with glossy green plume feathers; wings slightly pencilled with black. Pullets white, with black tails, and neck hackles pencilled with black. The comb is small and serrated, though frequently they have the perfect pea-comb of the Sumatra Pheasant Game fowl—always a rare indication of fineness of flesh. The wattles are small, but the ear lobe extremely large and pendulous. The legs are yellow, and usually very heavily feathered, though I have seen some excellent specimens with smooth legs. Their weight, at maturity, is from 22 lbs. to 25 lbs. per pair, and they are quite symmetrical in their conformation. As layers they are unsurpassed by any breed. I have tried them side by side with the Imperial Chinese, and the Shanghae, and find the three breeds about equally prolific. They lay a larger egg than any other Asiatic fowl, not excepting the great Hoang-Ho fowls recently imported from Shantung and Honan, in the valley of Hoang-Ho river. On an average, their eggs are fifty per cent. larger than those of the Shanghaes or Imperial Chinese. They differ from the *Gray* Shanghaes in the following respects:—They are lighter-coloured, shorter-legged, more compact in form, have larger ear-lobes, and smaller combs and wattles, deeper-breasted, but shorter-quartered. They are more active, and better layers."

Mr. Miner, the editor of the "Northern Farmer," says:—"We presume that there are no larger nor better-shaped fowls in existence than the Brahma Pootras, nor any that lay so large an egg. They equal the best in laying, and some contend that there is no fowl that can equal them in this respect. They can be confined by a fence four feet high, effectually, not being able to fly at all, in consequence of the shortness of their wings. They are not disposed to ramble, if allowed, but remain constantly near home. They are particularly fond of grass, and seem to live almost as much upon it as geese. We have been surprised at the small quantity of food they consume. One quart of corn, and the same of corn-meal, ground in the cob, is as much as one pair of old Brahma Pootras, one ditto of Hoang-Ho fowls, and twenty-one chickens from three to four months old, now consume daily."

The Rev. R. W. Fuller, of Massachusetts, in a letter to —, says:—"I have a pair of Brahma Pootras of the same breed as those of Dr. J. C. Bennett, and I consider them decidedly the most beautiful and splendid fowls ever imported into this country. Their colour is white, inclining on the back to a rich cream colour; the hackles on the neck slightly streaked with black. The legs are yellow, heavily feathered with white, and shorter than the Chittagong or Shanghae, giving the fowls a more beautiful proportion. They are very gentle and peaceable in their disposition, and have a stately and graceful gait, &c."

The committee of judges on the different classes of fowls

exhibited at the annual exhibition of the "New England Society," for the improvement of domestic poultry, held on the 11th, 12th, 13th, and 14th days of November, 1851, speaking of the Brahma Pootra fowls, say:—"Some mammoth items of this variety were shown by Dr. Bennett, S. O. Hatch, and J. Parkinson, each possessing great merit. Mr. Hatch's lot was entered under the head of Gray Chittagongs, but were really pure Brahma Pootras, and decidedly better fowls than any Chittagongs in America. They are better layers, lighter in colour, have shorter legs, more

compact forms, larger ear-lobes, and smaller combs and wattles, and in every respect are vastly superior to the Chittagongs. As the judges desire that every variety of fowl should be called by its right name, they cannot sanction the application of the title Chittagong to this excellent stock, when in reality they are perfect Brahma Pootras."

The novelty of these details, and the interest with which they will probably be regarded by many of your readers, must be my apology for troubling you with so long a communication.—W. C. G.

FLOWER-GARDEN PLANS—No. 3.

HERE is the first fruit of the criticism on the Plan No. 1. I am so unwilling to let it pass for another month, that I am under the necessity of sending it to the engraver by "return of post," so the planting must be deferred for the present. In another month or two we may have a third plan out of the same original ideas as are evinced in the first; at any rate I shall not shrink from the promise to plant No. 1; and this in due time for next summer. How is it that none of our young readers, who understand so well the planning of a piece of ground, will undertake to show the planting of the beds? Surely it cannot arise from a dread that I should criticise them too severely. I do not know another branch of our calling so eminently qualified to teach one the art of thinking, as that of filling in, or planting, different designs on paper. Thinking is as natural to us as breathing the air; yet the art of listening and the art of thinking are more difficult to learn than the art of pruning roses or peach-trees. Practice is the best master after all, and without it, all our principles and ideas, our plans and criticism, and all our illustrations, go for little in teaching the young ideas how to plant. Therefore, let me urge once more on the attention of our young friends to make the best attempts they can for planting our first and third plans. All that I insist on is, supposing the plan is on gravel, that figures 6 be planted in

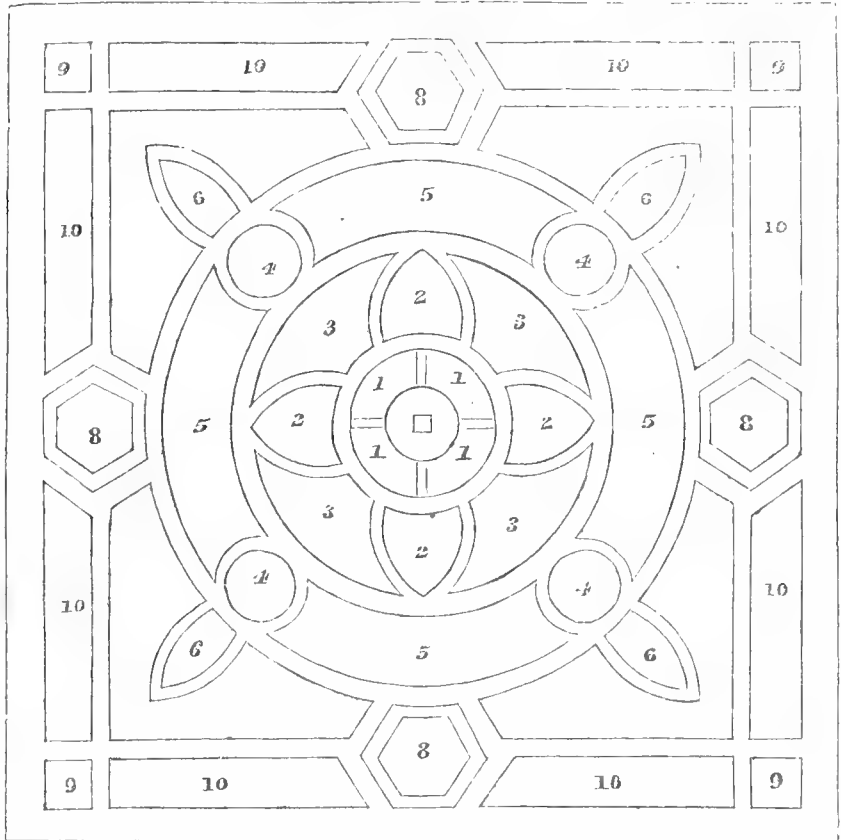

green without flowers; or, if the plan is on grass, that these sixes be planted with a low, very dark-flowering plant, as the dark variety of the double purple *Senecio* or *Emma Verberna*, according to the size of the beds; but the growth should accord with that of the plants on either side in beds 7.

The reason for this arrangement is, that all the No. 6 beds are so many expedients to take off the otherwise disproportionate size of No. 7; therefore, a colour in No. 6 contrasting, or harmonising, with No. 7, would be like a house divided against itself; or, easier, if we call No. 7 a house, and the flowers in it a roof or thatch, No. 6 being part of it. Would it not look very odd to have the part No. 6 covered with slate, and the rest thatched with straw or reeds? But you would not think it out of place to have Nos. 6 or 7 covered with straw, and the rest covered with reeds, although the colour of the straw and reeds might not be exactly alike. It matters very little whether you make the corner figures, Nos. 9, flowers, vases, a single cypress, or Irish yews. The rest is easily done, if you keep in mind that the very centre is a vase, and may be four feet high or more; therefore, the plants in the four beds, No. 1, need not be quite so dwarf as the size of these would indicate. The leading principle of this plan is the least understood of all the tactics of flower gardening. I allude to the principle by which your company are turned right or left, or "all round," before they can reach the centre, and this I shall illustrate by a thing in season. Suppose we have a country dance of sixteen couples, and that the first couple join hands, then down the middle and back again, and so on with the whole of them, what a tiresome dance it would be;

but not half so bad as going straight forward to the middle of a flower garden. The most indifferent of a whole party, as to flowers, could not get along in the above plan without being compelled, as it were, to look at them, if only to see that he did not trample on them as he went about.

D. BEATON.

DISEASES OF POULTRY.

APOPLEXY.

A HEN, two years old, who had laid almost daily for more than a fortnight, was accidentally shut out from her usual nest for two days, and did not lay during that time, upon access to her laying place being opened, she was observed to proceed thither, but in five minutes after was found dead upon her back. The body was sent to Mr. Tegetmeier, and the following is his report, affording one more warning against the mistake of high feeding breeding hens.

"I have carefully examined the hen forwarded by you. She was in high condition, and, for a laying hen, extremely fat; the digestive organs were perfectly healthy, both the crop and gizzard filled with food; the oviduct contained a perfect hard-shelled egg, which would evidently have been laid directly had the hen lived; there were also numerous immature eggs, one of which had been broken by some concussion after death. All the organs contained in the body were in perfect health. Around the top of the spinal cord and base of the brain was a considerable quantity of

coagulated blood, which had escaped from a ruptured vessel, and by pressing on the brain, &c., had caused death; it was, therefore, as you suggested, a case of apoplexy. I should be inclined to doubt the disease being caused by the hen's having been accidentally shut out of the laying house; but I should feel inclined to attribute the attack to the extremely high condition of the bird. W. B. TEGETMEIER."
"Tottenham."

DAHLIAS OF 1851.

(Concluded from page 187.)

MALVINA (Turner); rather flat on the face; but, if all the flowers are left on the plant, and put out early, it will make a very useful flower, it being of a colour we want.

MORNING STAR (Turner); very bright in colour, but I do not like the form; and the petals are very rough. I shall not grow it.

MRS. SOUTHEY (Whale); useless.

NIÖBE (Salter); white tipped with rose. Rather too large as grown by me; but I think by leaving all the blooms on the plant this will be a really first-rate flower.

PHANTOM (Noakes); large, coarse, and bad.

REMBRANDT; orange, striped with red; very bad habit, but not bad in form, and will be useful as a striped flower. I shall grow it again.

SCARLET KING (Green); the petal is good; but every bloom is too low in the eye for a show flower; it comes too coarse.

REDGAUNTLET (Keynes); this flower was sent without charge, and was worth several that were charged; being a good red, every bloom perfect, and well up. I shall grow it again, as I think it the best red yet out.

SIR F. THESSEGER (Rawlings); very fine; rosy lilac; particularly late in the season. One of the very best forms, and ought to be planted very early.

UNA (Keynes); white; rather thin, but good eye. I shall try it again, but do not quite approve of it. Always constant with me, and fit to show.

VICTORIA (Cook); crimson tipped with lilac. I do not like it; it is too low in the eye.

WHITE STANDARD (Brittle); blush white; very good with me; form first-rate. I shall grow it again.

MISS BATHURST (Dodd); pretty colour, but too thin. I shall not grow it again. It is a fancy flower.

MISS WARD (Turner); another fancy yellow tipped with white. Not good.

NANCY (Keynes); dull in colour, but form very fine. It requires a moist growth. I had a few blooms quite models, fit for any stand. Fancy red tipped with white.

QUEEN OF WHITES (Drummond); rather flat; good colour; and will be very useful. I shall grow it again.

SIR R. WHITTINGTON (Drummond); dark ruby; quite a gem. Rather low in the eye sometimes, and requires good growth. First-rate in every respect.

SPARKLER (Barnes); very so-so. I shall not grow it again.

SPECTABILIS (Salter); another striped flower like *Rembrandt*, but decidedly better in habit, and I consider it a better flower. I shall grow it again.

TOM (Drummond); comes all one-sided; petals not regular. I like to see them laid on like scales on a fish's back. Not good.

TRUMPHANT (Keynes); this flower came at first very small, and low in the eye; but having strong plants I cut out very severely, and had some very first-rate blooms, nearly all selfs. I had two fancy blooms, and they were exquisite. It requires extra good growth.

This completes my memorandum. I have given my opinion without fear or affection, with honesty of purpose; and I think growers may depend on these remarks, for they are pretty true.

OBSERVER.

NORMANDY.

(Continued from page 273.)

Though the whole of Normandy may be spoken of in general terms as a province of tolerably uniform character,

fertile, undulating, well-wooded, and well-cultivated, with a marked race of inhabitants (a Norman type of physiognomy and general build is perfectly distinguishable), still, different districts differ in a few slight points of manners and of produce, which I may perhaps by-and-by particularize. For instance, in the Cotentin you find that article of bedding which you had left behind you in Germany, the *edredon*, or bed of eider-down, to lay over you instead of blankets. It is not at all a French fashion; the reason you find it here is, that there has been long and great intercourse between the Cotentin and Iceland. But the caps of the women are the most strange, varying, and distinctive evidences of topographical peculiarity of costume. Each town and neighbourhood has its own cap to display; so that, as these forms are very ancient, an illustrated treatise on the caps of Norman women, with portraits, millinery details, and a map, would be anything but an uninteresting contribution to Ethnology. They are quite as characteristic as the costumes of the Swiss Cantons. To describe them intelligibly is next to impossible. The simplest and the ugliest form is when the woman wears on her head a common white-cotton man's night-cap, with no other ornament than the tassel at the top. It made me think of women going to be hung. About Caert is the head-quarters of these unfortunates. Others there are that seem to have a white apple-turn-over laid upon their forehead; others, again, have modelled their caps after the pattern of an extinguisher. About Candebeac and La Mallerie is a tall cylindrical species of cap, which we called "church-steeple," surmounted by streaming ribbons, and finished off with a couple of mainsails at the base. One form, which just manages to miss being a becoming head-dress, is that whereon the lace or net border is made to stand out stiff in front and all round, as if it were trying to imitate a saintly glory. At Vire, they wear a pleasing little sort of cravat tye, which Brummel must have envied if he ever saw it, on the top of the head, though not on the top of the cap. In the north of the Cotentin, as at Valognes, the head-dress becomes enormous: blown out with air, expanded with wire, and stiffened with starch, it is most imposing. But what becomes of it in an equinoctial gale would be interesting to inquire. Fancy a woman with a large white butterfly, a yard across from tip to tip of wings, alighted on her head, and then, from the place where the body of the butterfly would be, a muslin balloon arising of corresponding dimensions. And yet, with a dignified matronlike carriage, and the rest of the dress of rich materials, and neat, the whole effect is not ridiculous. Norman women of considerable substance still hold to the head-gear of their ancestresses. Some of these articles are even heirlooms. I am assured that there exists caps in Normandy worth from 1,500 to 1,800 francs a head, from the value of the Flemish and the English lace which adorns them; *point d'Angleterre* being in high favour. Observing an English lady make a full stop as she passed a tradesman's wife on Sunday afternoon, I inquired the reason. "Why, only look at that lace!" she replied. I did look, and lamented my want of connoisseurship. But the most elegant, if not the most costly caps are those worn by the women of Granville; there is a turning up at the sides, and a rolling back of the materials, which gives them quite an oriental or turban-like style. Add to which, that the face seen beneath is sometimes very modest, pleasing, and pretty. Granville would furnish a better model for a Madonna than any French town I know. It is said to have been originally a Phœnician colony; the costume, therefore, and the cast of countenance, may be relics of the east. But Granville is altogether remarkable, from its rock, its granite church, its oyster *parcs*, and its long-descended inhabitants. Little girls do not wear these curious caps, nor can I say at what age they assume the head-ornaments of womanhood; probably, like young Guinea-Fowl, they shoot their horn when about two-thirds grown, for at Avranches, where they wear a sort of blue paper or silk dunce's cap, as the foundation for the muslin and the lace, I observed some young women who might be four feet high, and they were topped, or continued, or *produced*, in mathematical language, by caps at least half as high as themselves. Do not imagine that the subject of

Norman caps is exhausted; it is scarcely yet touched upon, and promises to be as interesting to the artist and the antiquary as that of Norman architecture.

Normandy is milder and damper than Picardy. A very few slight observations will tell long tales about the meteorology of any country. A gardener especially has his eyes open to these trifling but significant phenomena. Where I am writing, we have standard fig and apricot trees. Wherever standard fig trees answer, the winters cannot be very severe; and wherever standard apricots bear good fruit, the summers must be tolerably genial. Ferns are seen growing in spots where they could not easily exist if they were usually surrounded by an arid atmosphere. The advertising appendix to my "Murray's Handbook," contains some beautiful little fronds gathered on the granite rocks at Vize. The thatched cottages in Norman villages are very fond of wearing, on their ridge or backbone, a decoration which looks like the erected bristles of an angry wild-boar: it consists of a row of iris, or orpine, or poly-pody, according to the taste of the proprietor, planted in a line of clayey-earth along the very top of the angle formed by the roof sloping each way; and it mostly flourishes, and flowers, and waves in the wind, with a luxuriance unattainable were it not frequently watered by a supply of visible or invisible moisture. Notwithstanding this, Normandy is one of the healthiest provinces in the world.

For comparison's sake, I may observe, that the climate of the north-east corner of France is more variable than in most other parts of the country. The map will show that a north or a north-east wind reaches it unmitigated from the North Sea itself; whereas, the departments but a little to the west are sheltered from these inclement breezes by Great Britain, which tempers their rigour and breaks their force. On the other hand, a wind from the south and the south-west comes charged with all the warmth it has collected in passing over an extensive continent, so that within the course of a few days very considerable alterations of temperature, of drought and moisture, may be felt. At the beginning of the week you are melting with Italian heats—at the end of it you are shivering with an Orkney chill. Hence the local proverb respecting the month of April, which might, without injustice, be extended to May.

*Avril, il est doux;
Quand il s'y met, il est pere de tous.*

April and May are soft and mild;
When they once set to work, they're the worst of the wild.

Against these sudden changes, delicate and susceptible constitutions should be on their guard, by keeping warm clothing ever at hand; otherwise, the country in the uplands is very healthy. The pure air of the hills, the gales that sweep over the unclosed fields, and, for a great part of the year, the extent of the dry-growing woods, manifest their usual effects on the appetite, the spirits, and the complexion. But towns situated low, at the mouths of rivers, or on the site of ancient marshes, as Gravelines, Dunkerque, and St. Omer, are apt to have insinuations thrown out against their character for salubrity. Normandy is also variable, the Cotentin particularly so; but except in one or two spots on the Seine, and there only in the autumn, I have not heard a whisper of malaria.—D.

ON CIDER-MAKING IN THE COUNTY OF HEREFORD.

As "Somersetensis" wishes for information respecting the mode of making Cider in the counties of Hereford and Gloucester, the writer, who has, during the last few years, visited the former county during the cider season, is willing to afford such information as he is capable of doing, and which has passed under his general observation.

There is much to be said in favour of their system, still the process is of that slow nature that few Somerset cider-makers, who generally make from 100 to a 1,000 hogsheads annually, would adopt it, as no doubt much waste would occur from the fruit getting too decayed before it would be possible to make it into Cider; as I should think, that with the mills and screw presses used in Somersetshire, five

hogsheads are made with the same labour as one in Herefordshire.

As you travel through the counties of Hereford and Gloucester, you are not struck with the quantity of orchards (as in Somerset), and the trees are generally small. The pear trees seem to thrive much better than the apple trees, and they attain an immense size, from which a great quantity of Perry is made. The same mills suffice for both, and, as before said, the quantity of Cider not being large, the quality is of great importance, and that is obtained by the means of crushing and grinding their apples under a heavy stone cylinder moving vertically in a circle, which, being fixed in a frame, is propelled by a horse round a bed or trough into which the apples are placed. The pulp is scraped into the centre of the bed, by means of a scoop attached to the frame, and following immediately behind the stone, which continues to roll round till even the pips are entirely bruised, from which a strong aromatic flavour is obtained, and which adds so much to the quality of the Cider. As soon as the pulp is sufficiently ground, it is placed in horse-hair bags, and the juice immediately pressed from it, which has such a muddy, filthy appearance, that no one would imagine such a delicious beverage could afterwards be obtained from it. The usual fermentations and rackings then take place as is practised by experienced cider-makers in Somersetshire. A few enterprising farmers, in the neighbourhood of the city of Hereford, lately obtained some of the Somerset mills and presses, imagining that from the quick mode of making it they should save a great amount of labour, but I believe there is not an exception in which they have not all discarded them, and returned to their old system, finding they lost in the quality as well as quantity of their Cider.—T. D. P.

MISCELLANEOUS REMARKS ON POULTRY.

FEEDING.—This subject is not generally so well attended to as it deserves; it is true, where fowls have a good run they can provide themselves with many a dainty morsel, and will do well with one good feed of corn per day; but it is not always that persons keeping fowls can accommodate them thus extensively, and it is therefore necessary to provide what they require by artificial means. Most fanciers are aware that fowls require other things besides sound corn for their welfare, such as green, and animal food, calcareous matter, and grit; and I consider it absolutely necessary for them to be supplied with these more particularly while laying and moulting.

The green food may consist of grass, lettuces, chicory, cabbage, &c. The animal food is, naturally—snails, beetles, grubs, worms, maggots, &c.; and, when a supply of these fail, then butchers' offal, tallow chandlers' greaves, or any refuse meat, will be found very advantageous. In winter, an allowance of fat will be found beneficial, as, by the internal combustion of the carbon, of which fat is principally composed, the animal heat will be sustained, and, consequently, laying will be promoted.

Calcareous matter enters largely into the formation of bones and egg-shells. Chalk, in small pieces, is recommended; but I do not find the fowls very fond of eating it: naturally, they eat the shells of snails, and other small land shells, which, with the hard covering of beetles and other insects, contribute largely to the production of egg-shells. Egg-shells, thrown from the house, are greedily eaten. The best substitute I have found to consist of bone-powder, a small quantity of which may be given daily in their food; and this I have found to cure some of my high-bred hens of laying soft eggs, when a regular cramming with chalk did not succeed. Hempseed, linseed, and sunflower-seed, are very nutritious, and conducive of laying.

For rearing young chickens, I have found milk-curd (where easily obtained), mixed with ground oats, to be the best food; where not obtainable, I use ground oats, mixed with water, with a small quantity of bone-powder added; or rice, parboiled and rolled in ground oats or barley-meal, so as to separate the grains. And a piece of bullocks' liver, boiled hard and grated, is also an excellent occasional treat for the little chickens. Ducks are famous trenchermen,

and require to be filled. I have found stinging-nettles, chopped and moistened with pot-liquor or wash, and mixed with a small quantity of pollard or meal, to be a cheap food, and, with an occasional feed of corn, they thrive well on it.

INCUBATION.—I have kept an account for some years of the time my various birds sit, and the following is a list of the time occupied in hatching their eggs:—

Canary birds, 14 days; Doves, 14; Pigeons, 16; Fowls, 21; Guinea fowls, 25; Ducks, 26; Turkeys, 26; Geese, 31; Muscovy ducks, 35.

Although Ducks and Turkeys hatch in 26 days each, I have found, when the eggs were set together, that the Turkey-eggs hatched about six hours earlier. I believe the above list to be quite correct; but I have known most of them occasionally to have been longer through accidental causes.

HATCHING NESTS.—These I prefer on the ground, and formed of damp turf, lined with dry heath and Lichen or Liverwort, collected from trees, &c. The nest should be made so large that the hen can just fill it, not very deep, and as nearly flat inside, at the bottom, as possible, so that the eggs may not lean against each other, or they are very liable to be broken, especially by the hens turning them. A little Scotch snuff is also a good thing to keep the nests free from vermin. Why I recommend ground nests, and rather damp, is, that it is admitted, that the hen that steals a nest in a hedge or coppice generally hatches all her eggs, and brings home strong chickens; whereas, the one that sits at home, in a dry box or basket, often spoils many of her eggs, and her chickens are frequently weakly, which I attribute to the great evaporation that takes place from the egg during incubation in such unnaturally dry nests, which also renders the chicken feverish and weakly. In support of which opinion, I can say, I have hatched my best broods in nests thus made and well moistened; and frequently have not had one egg in a sitting miss.

BREEDING.—Never breed from relations; always select strong, healthy birds of the same variety; do not think, by mixing the sorts, to improve a breed, a cross may do well enough to eat, but if a breed is crossed it is not to be depended on afterwards, as they will often run back for many generations. The formation of a new variety will take a very long time, and then mostly ends in disappointment. Keep each breed pure, and improve it by saving the best specimens, and add good fresh blood of, as near as possible, the same.

I think the eggs of a hen may be depended on during three weeks after her removal from any male, and without being put to another. Thus, I found the eggs of a hen that had been removed from a game cock took after him till the tenth day of separation; and that the eggs of another, that had not been with a rooster, produced chickens as early as the fourth day after being put to one. The hens in both cases were laying.—B. P. BRENT, *Bessel's Green, Sevenoaks.*

PENS AT POULTRY SHOWS.

ALLOW us to offer a few suggestions upon Poultry Exhibitions, as they now bid fair to be as numerous and of as frequent occurrence as our Horticultural and Agricultural Shows. With the latter, indeed, we now generally find them united, and those who are lovers of the feathered-race would think it an unpardonable omission if they were not so. This taste is steadily increasing, and but few districts, within a short time, will be without, at least, its annual Poultry Exhibition. This, we think, would be readily effected if any plan could be devised so as to facilitate their arrangements, decrease the expenses, and diminish the labour of their committees of management.

One question is—Could this not be done simply by requiring parties exhibiting to send their birds in such baskets, or pens, in which they could be shown, to be made after a prescribed design, or pattern, so as to preserve their uniformity? This would remove, at once, the great impediment to provincial and local exhibitions, and without increasing greatly, if any, the expenses of the exhibitor; besides, which is of still greater importance, with much less risk of injury to the birds sent, as they would not have to be

removed from basket to pen, and from pen to basket. Last, but not least, such a plan would curtail, by many hours, the bird's confinement, by greatly facilitating their reception, arrangement, and returning. Such moveable pens would also afford judges advantages in cases of nicety of decision, by placing the birds in their own baskets along-side of each other, which cannot be done in the fixed pens without catching the birds.

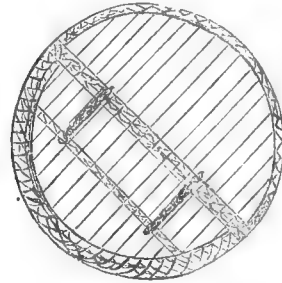

The above is the style of basket we propose. It was the one used at our last Cheltenham Exhibition. The baskets were arranged on elevated platforms, or tables, about two feet high, showing the birds off well to the viewer, and at the same time giving a light and pleasing effect. Turkeys and pea-fowls were, on account of size, exhibited in built pens. The baskets were of three sizes, viz., first size for the larger varieties of fowls and ducks, 2½ ft. in diameter and 2½ ft. high; second size, for the smaller, 2 ft. in diameter and 2 ft. high; third, for pigeons, 1½ ft. in diameter, and 1½ ft. high.

The fowls were exhibited in threes, geese and ducks in couples, pigeons in pairs, chickens in fours. A canvass wrapper, or bag, should be put on the basket when travelling, taken off on arrival, and neatly tied on the side, covering about one-third part. Thus protected, the baskets could be placed close to each other without fear of any combative encounters.

We hope to see soon some general style of poultry-exhibition-basket devised and adopted, so as to facilitate and encourage the getting up of these now useful and entertaining exhibitions, making it no longer a difficult matter for the clergy and others of our rural districts to accomplish.

JESSOP, BROTHERS, *Cheltenham.*

[This suggestion we think very good; but we question whether a better shape would not be that of a parallelogram with the whole front to let down; like a milliner's basket, placed upon its side.—Ed. C. G.]

PREPARATION OF MUSHROOM BEDS.

ALTHOUGH the majority of growers, whose number of beds are limited, generally make them all up in the autumn, and trust to their continuing in bearing the whole season

after they have begun, yet there are others who, having the necessary means and conveniences, make up a bed occasionally all through the season; a few words to such may be both seasonable and advantageous, as it must be understood, that the same means used in September or October are more likely to become successful than those used in January. The reason "why," is not so easily explained in this case as that of many other problems in forcing; unless we take it for granted, that the spawn runs with more avidity in those months immediately following the period when it is found producing mushrooms in a natural way; or, perhaps, the absence of success may be traced to something defective in the spawn used, which, however, can hardly be the case, because we have used it at all seasons, and have generally found that put in about the month of October the most productive of any; even where a later crop had many other advantages. Another thing late mushrooms have to contend against are the attacks of innumerable insects and other enemies, whose destruction or prevention is more difficult than might at first be supposed; but such is the case, and beds bearing late in the spring become infested with maggots and the numerous small fry which find their way into such snug quarters as this favourite production is often treated with. Nevertheless, where mushrooms are wanted for table all the year, successional beds must be made; and the remarks we now offer on their formation will serve, with some slight variation, for the whole year.

In the first place, a supply of good useful dung must be had; that of horses has from time immemorial been recommended, but that of sheep, and, I believe, deer, might be profitably used likewise: certain it is, that I have seen an excellent crop of mushrooms from a bed formed of sheep-dung alone; and, what may not surprise those who know its value, the specimens there produced were thicker and better in substance than those from horse dung; and though the bed was exceedingly thin, and partly mixed and coated with loam, yet it continued to bear for many weeks; but then it was formed at a more favourable time of the year than this. Still, I must admit, that a quantity of sheep dung mixed with the other is attended with a benefit, and as it is often to be had in considerable quantities underneath trees and other sheltered places where sheep are accustomed to rest at nights in the autumn, its collection and removal from thence is both easy, and little or no detriment to the land it is taken from. Horse dung is tolerably well known, and for purposes of mushroom growing, at this untoward season, should be procured without being heated; it is not easy to have it so, if an accumulation of it be left for many days—and it is not too much to say, that throwing it up into a heap when fresh, and allowing it to lie untouched for only three full days, will have seriously injured it for the purposes we now intend it for; or, in fact, for heating purposes either. True, three days may be insufficient in some instances; but in others we know they would; and we therefore warn the inexperienced particularly on this point. For dung that has undergone a heating process to a degree that would almost cook food, has parted with some of its most nutritive parts, and would seem little better qualified to maintain vegetation than the ashes or other residuum of a furnace, which, we all know, are for a time sterile; but by exposure to the atmosphere, and, perhaps, the conjunction of other matters, lose their pernicious qualities and, assimilating to themselves those of an opposite kind, speedily become fertile in their turn, and, in many instances, are used as such with advantage. Now though we cannot affirm that horse dung that has been heated so as to become white, and remains so, is absolutely poisonous; yet it is beyond a doubt, that in that condition it is repulsive to all but the lowest class of vegetation; that class to which the "mould" and mildew owe their origin, and whose dominion is said to be more extensive than any other. But though the mushroom belongs to a family related to this pernicious one, yet its presence is not so universal, and is generally hailed with delight when it shows itself, instead of that dislike with which the many species of mildew and its kindred species are regarded by all but the enthusiastic botanist who makes this abstruse part of the science his particular study.

Returning again to the subject, I may say, that fresh horse-dung—that has neither been soaked in rain nor overheated—may be prepared by separating as much of the littery matter as can well be done, and the heap thrown up to heat a little; but as soon as it reaches a degree of warmth which is uncomfortable for the hand, it must be turned, and that process repeated almost every day for a few times, after which it will gradually subside in heat, and longer intervals between turning will suffice, until that moderate sweet heat be attained which is tolerably well known to the practical man; even the uninitiated may have a tolerably good knowledge of its ripeness for use, by the mild, steady warmth it furnishes. Now this state of preparation may be carried too far; dung may be worked over and over until its heating qualities are entirely spent, so that when applied to the intended purposes, it is no longer able to command the warmth needed. I may observe, that in about the middle of its preparatory course the sheep dung may be added, and if it be done in any quantity exceeding one fourth of the whole, the increased heat accorded will require corresponding caution on the part of those having charge of it; and it must not in any case be used until it be subsided into that steady mellow warmth which is alike congenial to all around it, and lasting in its effects; even then, at this late period, beds made up ought to be in such a situation as to have the advantage of fire, or other heat, apart from their own; for though the mushroom would seem to relish the cold dews of autumn, when growing in the open air, yet when in an artificial condition, a certain amount of heat is requisite to bring a bed of it into good bearing; so that, after all, one of the principal secrets in the growing is to furnish it with that amount of heat calculated to stimulate it. Therefore, any beds that appear sluggish are often rendered productive by the application of fire-heat, heating the atmosphere, or, it may be, something in the way of dung linings, warming the bed, when the former is impracticable. But at this season, new beds made up must be kept up tolerably warm, and being spawned so, the heat ought not to be allowed to subside until the bed begins to bear. This course cannot always be followed, but may be partly so. If necessity compels the bed to be made out-of-doors, let it by all means have an amount of covering calculated to throw off all wet likely to fall; or, in fact, it ought to have some waterproof covering apart from the litter which forms its coating, and, if needs be, hot dung must be applied to its sides.

Out-door beds are more extravagant in the quantity of dung they require than those on shelves, or in any sheltered in-door position; the extra bulk being wanted to maintain that amount of warmth, without which success is uncertain. The mode of making them is tolerably well known. A site being fixed on, which ought to be as dry as possible (under a large tree is not a bad place), and the length marked out, the dung is then spread over to the width of about four feet, which is trod firmly, and more added, building up the sides as you proceed, so that the bed be firm and even at the last; it will not settle much; so that if it be made at this season, and the dung has been previously well prepared, it may be spawned at once, and a covering of litter put over it, which, however, must be withdrawn if the heat increase so as to appear likely to be excessive; it is easy to ascertain this by sticking a stick or two in the bed, and examining them at times. Spawn must also be used with a more liberal hand now than earlier; and if the moist warmth of the bed dampen the litter which covers it (which it is almost sure to do) this must be exchanged for drier covering. A very little degree of warmth is sufficient to start the spawn; but should it subside until scarce any exist, hot dung must be applied against one side of the bed, which, though it may kill the spawn ~~it is~~ in immediate contact with, it will most likely induce a good crop to present themselves on the opposite side. These means being adopted will, in most instances, increase a supply; but it is certainly more likely to be so when fire-heat is applied; and this may be done in many cases where there is no regular mushroom house. A vacant corner or space in the neighbourhood of the stock holes, where fires are kept on constantly in forcing operations, may be made into an excellent mushroom bed, in which case, or in those made on the shelves of a house set apart entirely for this duty, a much less quantity of dung is wanted. In fact, when

atmospheric warmth can be supplied, a bed a foot thick is sufficient. A good, but not severe beating or treading may also be given this, and the spawn scattered over it, or rather dibbled in, and the top coated over with an inch or so of good sound loam, is all that is wanted. Observe, the loam had better not be applied if any danger of over-heating exist, which, however, with well-prepared dung, can hardly be the case. Watering will, in a manner, depend on the dryness of the atmosphere, and other causes; but a dry, harsh air is inimical to the growth of this plant; and, if it needs must be so, the bed must be covered over with loose hay or litter, which must be frequently sprinkled with water. A heavy watering may sometimes be given to an old exhausted bed with advantage, because, if accompanied by increased heat, a large second growth occasionally takes place—but, of course, this is not of long continuance; but, for many reasons, it is advisable to try it before finally condemning an old bed. Those now in bearing will need occasional watering only, for, in a usual way, the moisture with which the dung has been charged with is sufficient for the support of the crop, until a later period, or until fire-heat or other cause has rendered watering necessary, of which it will itself give tokens. JOHN ROBSON.

SHANGHAE FOWLS.

AFTER reading the statements of "Gallus," concerning our pets, the Cochinchina fowls, will you allow me to give you a correct calculation of my own fowls. I have sixty Cochinchina pullets, and ten cockerels; fifty Dorking and Spanish. My fowls are fed from Indian corn, barley-meal, and wheat; they have as much as they can eat; and, during the experiment, were fed from my own hands; and, including every grain of corn, my pets have not cost me more than one-penny-farthing per week; my Dorking and Spanish cost two-pence; they were fed by a confidential servant; I can vouch for his calculations being correct. The weight of my largest Cochinchina cockerel is eleven pounds, the smallest six-and-a-half. I think, Mr. Editor, if you could see my beautiful pullet, Bessy, weighing eight-pounds-and-a-quarter, a pet of my husband's, you would not allow another word to be said against our friends! "Gallus" alludes to the eggs of the Cochinchina fowls being inferior to the Spanish. His taste for eggs must be very different from others. My friends say it is a great luxury to have a Cochinchina egg for breakfast. I feel inclined to think his birds are not pure, but I am not going to argue with "Gallus" about his birds; my object is to convince the readers of THE COTTAGE GARDENER, that Cochinchina fowls can be kept for one-penny-farthing per week each, and well. My fowls are kept in separate walks. I do not allow the Dorking and Spanish to molest my pets with their voracious appetites. We do not intend to keep any but Cochinchina fowls, as they are the most useful. AUGUSTA.

TO CORRESPONDENTS.

. We request that no one will write to the departmental writers of THE COTTAGE GARDENER. It gives them unjustifiable trouble and expense. All communications should be addressed "To the Editor of the Cottage Gardener, 2, Amen Corner, Paternoster Row, London."

ERROR.—In the advertisement of the *English Flower Garden*, in our number for December, it ought to have been stated, that it is embellished with a coloured figure of *Skimmia japonica*, and not of a *Skinneria*.

POTTED HYACINTHS (*Weyham*).—Your Hyacinths, "though not above an inch high, many of them are showing the flower-bud," and you take alarm. Your management, "keeping them in a dark closet for a month," was quite right, and you could not report more favourably if you had sat up to watch them, day and night since they were potted. They will be all right, unless the flowers begin to expand at the dwarf height you mention.

TAYLOR'S HIVES (*An Old Subscriber*).—The bars are half-an-inch thick, and the same throughout. The floor-board figured in THE COTTAGE GARDENER for February 12th, 1852, overhangs the sides of the box all round, three-quarters-of-an-inch. The length of opening, *b* and *c*, are three inches. The width of groove, *a*, two inches. Each box has its own top and floor-board, and the zinc slides run between them. The top of each box is secured by three screws. The glasses are round, with flat tops, and may be had of Messrs. Neighbour, one large, or two small ones, may be used.

GATHERING APPLES AND PEARS (*An Irish Subscriber, Dublin*).—Your enquiry about the proper time to gather Apples and Pears opens a very wide question, which may scarcely be settled in a few lines. The

old maxim was to be ruled by the colouring of the seed, and we are not aware of any safer guide. We believe that to be an indication, in general, of certain chemical changes having taken place, or being in progress, which constitute ripeness, and point in many fruits to their having attained keeping properties. But there are several exceptions, and as yet, we have all much to learn, doubtless, with all our experience. There are the *Easter Beurre* Pear, also the *Williams's Bon Chretienne*, let them ripen on the tree and they are not worth eating. As a general rule, fruit should be easily removed when ready to gather. As to preservation afterwards, they require a cool, tolerably dry and dark situation, with a guarantee against frost; a constant temperature of 50°, would, doubtless, be capital. No fermentation may be thought of; no bruising or rough handling allowed.

FRUIT-TREES FOR CUMBERLAND (W. R.).—PEARS.—Beurre d'Amaluis, Dunmore, Williams' Bon Chretienne, Muirfowl Egg, Althorpe Crasanne. We do not say those are certain to succeed, but we should try them. In your APPLES, why have you put American Newtown Pippin? Why! it has greater need of a south-wall than a Peach! Add Lamb Abbey Pearmain, Williams' Pippin, Fearn's Pippin, Mank's Codlin, and Beauty of Kent.

PHYSALIS EDULIS.—G. S. has obligingly sent as requested. He says:—"The seeds keep best in the fruit. They have not ripened kindly this year, but if fully swollen in the autumn they ripen very well in-doors. To make the preserve worth eating, it is necessary to boil the fruit a very long time. When slightly cooked, as in a tart, they are not worth much."

DORKING FOWLS (G. E.).—No one knows that these "originally had a double or rose comb." We believe the contrary, and that all double combs are really malformations, however much they may be prized in some varieties. The fact you mention, that "double rose combs are extremely difficult to retain in the hens even of white Dorkings," supports our opinion. Any configuration retained with difficulty is not natural. We quite agree with you that single combs and double combs should be in separate classes.

HIGHEST PRICE OF A SHANGHAE COCKEREL.—We are informed that Mr. George sold his light cinnamon cockerel, at Birmingham, for £20.

VINES AND FLOWERS IN GREENHOUSE (*A New Correspondent*).—This can be done, though it requires much care to save the flowering plants from being drawn. If you buy our back numbers 92 and 127, you will find much information on the point.

FUCHSIAS BUDDING (*Picciola*).—Do not disbud them. You may keep the soil damped, but must not commence fully watering them until you can move them into the light and warmth. The mildness of the season occasions their growth; in Hampshire, Fuchsias in the open ground are coming into leaf. Very weak guano-water will benefit your potted Hyacinths, but they will not bloom until next year.

FRY'S CUCUMBER.—Such a notice is an advertisement.

WORK ON POULTRY (*Rhodon and A. M.*).—The illustrations will be exactly what you require.

GREENHOUSE BUILDING (*R. Bradbury*).—We will readily insert your description, but we must have full particulars, dimensions, &c. What "apparatus" did you put into the fire for heating the water?

OYSTERS (*G. Jones*).—It is quite certain that the natural position of the Oyster is with the flat valve of the shell downwards.

BLOOMING CINERARIAS EARLY IN MARCH (*An Enquirer*).—These should be showing their flower-stalks now. If not, keep them rather warm with plenty of air, and give no more water than will just keep them from flagging. Forcing the bloom thus, however, will not improve the healthy appearance of the foliage, but manure-water, after the flowering-stalks are rising, will give you strong blooms.

NEW GREENHOUSE (*W. E.*).—The fresh damp walls will be nothing in your favour; but as you have flues, you need suffer nothing on that account. Put a small fire in the flue at first, so as gradually to dry and settle the matters used in its formation, and then get a good fire on, which will help to dry the walls of the house. Anything like plastering at present would be out of place, but you may wash with a solution of quick lime. After a day's firing you may introduce the plants. In dull weather for the first season put on a little fire, and give plenty of air, using no more water than will be necessary. Here you had better get your Geraniums, Fuchsias, and Verbenas, and even your Roses if you have room; though Roses and Fuchsias too will do very well in the cold pits along with Pinks and Carnations. For covering the fruit-wall outside of such a house, 2 ft. 4 in. from the ground, so as to be gay in summer, and green in winter, many things might be tried. In the south of the island you might try the broad-leaved *Myrtle*, and in the climate of London, the *Japan honeysuckle*, trained lengthwise, would be sweet and interesting. In ordinary circumstances, *China roses*, well pruned every year, would be half evergreen in winter, and rich with flowers for pretty well nine months out of the twelve. We would recommend two dark ones, *Cramoiee superieure* and *Fabvier*, and two white ones, *Mrs. Bosanquet* and *Aime Vibert*. For the bed in front of such a house, 2 ft. 4 in. broad, and 22 ft. long, have *Winter Aconites*, *Crocuses*, *Snowdrops*, *Hepaticas*, *Tulips*, *Hyacinths*, and *Narcissus*, for winter and spring; and in May, fill with bedding plants, such as *Scarlet Geranium*, with an edging of *Mangle's Variegated*, or *Variegated Alyssum*, or low-growing yellow *Calceolaria*, or *Lobelia Speciosa*. This, however, is only one of many modes, as you will have already perceived from our pages. Any farther inquiries upon any specific subject will receive due attention. We have no doubt you will soon realise the benefit of the observations you have made abroad.

WEEKLY CALENDAR.

M. D.	W. D.	JANUARY 20-26, 1853.	WEATHER NEAR LONDON IN 1851.				Sun Rises.	Sun Sets.	Moon R. & S.	Moon's Age.	Clock aft. Sun.	Day of Year.
			Barometer.	Thermo.	Wind.	Rain in In.						
20	TH	Notonecta glauca; ponds.	29.769—29.695	49—28	S.	03	57 a. 7	26 a. 4	3 37	11	11 26	20
21	F	Sun's declination, 19° 51' s.	29.967—29.377	53—38	S.W.	26	56	28	4 44	12	11 43	21
22	S	Early Moth; hedges.	29.396—29.263	47—31	S.W.	—	55	30	5 49	13	11 59	22
23	SUN	SEPTUAGESIMA SUNDAY.	29.829—29.423	46—29	S.W.	—	53	31	6 47	14	12 15	23
24	M	Bay-shouldered. Button Moth.	29.831—29.559	48—34	S.W.	10	52	33	7 37	15	12 29	24
25	TU	CONVERSION OF ST. PAUL.	29.945—29.775	50—27	S.W.	16	51	35	rises.	16	12 43	25
26	W	Dromius linearis; bark.	30.073—29.903	51—41	S.W.	—	49	36	6 a 5	17	12 56	26

METEOROLOGY OF THE WEEK.—At Chiswick, from observations during the last twenty-six years, the average highest and lowest temperatures of these days are 43.3° and 33° respectively. The greatest heat, 55°, occurred on the 28th in 1846; and the lowest cold, 15°, on the 25th in 1827. During the period 91 days were fine, and on 91 rain fell.

BRITISH WILD FLOWERS.

POPPYWORDS.—PAPAVERACEÆ.

PAPAVER. POPPY.

Section II.—Poppies with smooth capsules.

(Continued from page 255.)

PAPAVER SOMNIFERUM: White, or Opium Poppy.

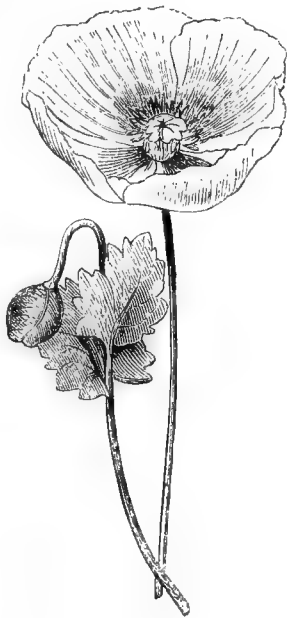

Description.—It is an annual. *Stem* from three to five feet high, smooth, but often hairy near the top, erect, branched, milky-green, leafy. *Leaves* large, grayish, wavy, lobed, and bluntly notched, clasping the stem with their heart-shaped base. *Flowers* at the end of the branches, three or more inches broad; hanging down whilst enclosed in the calyx, but becoming erect before the flower opens. *Calyx* of two oval, grayish sepals, which drop off soon after the flower has opened. *Petals* four, large, roundish, bluish-white, with a broad violet spot at the base of each. *Capsule* or seed-vessel, from two to three inches in diameter, globular, smooth, flattened at the top and bottom, sometimes rather furrowed. *Stigma*, or crown, eight or more rayed, with a broad, thin, bent-down margin. *Seeds* white, oily, sweet, and eatable.

Places where found.—Sandy soil, in fenny places.

Time of flowering.—July.

History.—Its specific name, *somniferum*, or sleep-bringing, tells truly of its powers. There are many varieties of it in our gardens differing in being double and semi-double, and in the varied colours of the petals. One, and, perhaps, a more permanent variety has *black* seed, which is used as a food for cage birds, and is commonly called "Maw-seed."

From this species is obtained *opium*, that drug so beneficial as a medicine, and so ruinous as an intoxicater. "It

is indeed," says Dr. Drummond, "an agent which can, for a period at least,

'Raze out the written troubles of the brain,
And, with a sweet oblivious antidote,
Cleanse the full bosom of that perilous stuff,
Which weighs upon the heart.'

But this is only for a time, and the charm being dissolved, the soul awakes from its trance only to experience aggravated woe, in those at least (and even in Britain the number is not small), who have fallen into the habitual use of this drug. If there be on earth a misery that approaches what we might be allowed to conceive as among the worst sufferings of a future place of punishment, it is the state of an Opium-eater, after the action of his dose has subsided. Unhappy and trembling, his head confused, and his stomach sick, remorse at his heart, but his resolution too feeble to attempt a reformation; feeling as an outcast from every thing that is good or great, he returns despairing to a repetition of his dose, and every repetition adds confirmation to the evil habit. His constitution becomes exhausted in a few years; he grows prematurely old, and dies of palsy, dropsy, or some disease as fatal: he dies, having by his own weakness and imprudence lived a life of wretchedness in this world, and looking forward at his exit to the darkest scenes of misery in the next. How often does man turn the greatest blessings into the greatest curse!"

Many attempts have been made in this country to obtain opium from the capsules of this species, and Mr. Ball obtained a premium from the Society of Arts for specimens of British opium, in no respect inferior to the best eastern opium. Mr. Young, a respectable surgeon in Edinburgh, has also obtained it of excellent quality and in considerable quantity. But we apprehend the climate, besides the destruction by insects, is an insuperable obstacle to its becoming a profitable branch of horticulture in Britain. It was very early cultivated in Greece, perhaps at first solely for the sake of its seed, which was used as food. It is extensively cultivated in most of the states of Europe in the present age, not only on account of the opium, for which it is reared in Turkey, Persia, and India, but also on account of the capsules and of the bland oil obtained from the seeds. All the parts of the poppy abound in a narcotic milky juice, which is partially extracted, together with a considerable quantity of mucilage by decoction. The liquor is strongly pressed out, suffered to settle, clarified with white of eggs, and being evaporated to a due consistence, yields about one-fifth or one-sixth of the weight of the heads of extract, which possesses the virtues of opium in a very inferior degree, and does not come to this country unless when used to adulterate the genuine opium. The heads are gathered as they ripen, and as this happens at different times, there are annually three or four gatherings. They are brought to market in bags, each containing about 3000 heads, and sold to the druggists. The London market is chiefly supplied from Mitcham, in Surrey. The heads or capsules possess anodyne properties; they are chiefly employed boiled in water, as fomentations to inflamed and ulcerated surfaces, and the syrup prepared from their boiled-down decoction is used as an anodyne for children, and to allay tickling coughs. A strong decoction of the dried heads, mixed with as much sugar as is sufficient to reduce it to the consistence of a syrup, becomes fit for keeping in a liquid form, and is the only official preparation of the poppy. It is, however, a very unequal preparation, as the real quantity of opium it contains is very un-

certain; as a medicine, it is by no means equal to syrup, to which a certain quantity of solution of opium is added. The seeds of the poppy are simply emulsive, and contain none of the narcotic principle. They yield a considerable quantity of oil by expression.

The milky juice of the poppy in its more perfect state, which is the case in warm climates only, is extracted by incisions made in the capsules and evaporated; and in this state forms the opium of commerce. The mode of obtaining it seems to have been nearly the same in the time of Dioscorides, as is at this day adopted. The plants, during their growth, are carefully watered and manured, the watering being more profuse as the period of flowering approaches, and until the capsules are half grown, when it is discontinued, and the collection of the opium commences. At sunset, longitudinal incisions are made upon each half-ripe capsule, passing below upwards and not penetrating to the internal cavity. The night dews favour the exudation of the juice, which is collected in the morning by women and children, who scrape it from off the wounds with a small iron scoop, and deposit the whole in an earthen pot, where it is worked by wooden spatules in the sunshine, until it attains a considerable degree of thickness. It is then formed by the hand into cakes which are laid in earthen basins to be further dried, when it is covered over with poppy or tobacco leaves. Such is the mode followed in India, and according to Kämpfer's account, nearly the same is practised in Persia; and when the juice is drawn in a similar manner in this country, and dried, it has all the characters of pure opium.

The Turks call opium *afioni*, and in the *teriakhana* or opium shops of Constantinople they take it in graduated doses from ten grains to 100 grains in a day. It is mixed with rich syrup and the dried juices of fruit to render it more palatable and less intoxicating, and is taken with a spoon or made up into lozenges, stamped with the words *Mash Allah*, literally meaning "The work of God." The Tartar couriers, who travel great distances, and with astonishing rapidity, take nothing else to support them during their journey. There is, however, some reason to suppose that the *Mash Allah* or *Mashash* of the Turks contains other narcotics, as those of *Hemp*, and *Lolium tremulentum*, as well as *opium*.

The use of opium for the purpose of exhilarating the spirits has long been known in Turkey, Syria, and China,

and of late years it has been unfortunately adopted by many, particularly females, in this country. Russel says that in Syria, when combined with spices and other aromatics, he has known it taken to the amount of three drachms in twenty-four hours. Its habitual use cannot be too much reprobated. It impairs the digestive organs, consequently the vigour of the whole body, and destroys also gradually the mental energies. The effects of opium on those addicted to its use, says Russell, are at first obstinate costiveness, succeeded by diarrhoea and flatulence, with the loss of appetite and a sottish appearance. The memories of those who take it soon fail, they become prematurely old, and then sink into the grave objects of scorn and pity. Mustapha Shatoor, an opium-eater in Smyrna, took daily three drachms of crude opium. The visible effects at the time were the sparkling of his eyes, and great exhilaration of spirits. He found the desire of increasing his dose growing upon him. He seemed twenty years older than he really was; his complexion was very sallow, his legs small, his gums eaten away, and his teeth laid bare to the sockets. He could not rise without swallowing half a drachm of opium.

Ever since the time of Paracelsus various preparations of opium have been commonly employed by medical practitioners. That physician and alchemist gave it both in pills and in a liquid state. The preparation of the latter he named *laudanum*, but kept its mode of preparation among his other secrets. The compounding of *laudanum* was first made public by Dr. John Hartmann, in 1631.

It must not be supposed that the active effects of opium are produced by one of its constituents only. So far from this being the case, besides containing meconic acid, caoutchouc or Indian-rubber, bussarin, resin, and meconates of lime and magnesia, it combines within its mass six peculiar ingredients, namely—Narcotiana, Morphina, Meconin, Narceina, Codeina, and Thebaina.

Narcotiana has been given in doses of sixty grains, without injury. *Morphina*, combined with an acid, is very active, one-fourth of a grain producing all the sedative effects of a large dose of opium. Of the medical properties of *Meconin*, *Thebaina*, and *Narceina*, we know very little; but *Codeina*, administered in doses of from four to six grains, produces excitement similar to drunkenness, but followed by depression and nausea. (*Martyn. Smith. Withering. Donn. Duncan. Thomson.*)

SINCE the establishment of THE COTTAGE GARDENER, every topic, we believe, connected with out-door matters, whether the useful or ornamental, has received attention, with the exception of landscape gardening, especially as applicable to moderate-sized grounds. We propose, therefore, to give a series of papers on this subject, and, to make them practically useful, it will be well to take the subject in its natural divisions, such as the approach walks, shrubberies, shrub masses, trees, water, rocks, &c.; and if we succeed in handling these in a proper way, we may serve to assist the owners of villas, &c., in determining the chief features of their grounds. To throw such materials into a whole, which we shall present in separate fragments, will be left to our great professionals, whose province we shall not dare to invade.

1st. APPROACH.—We may here observe, that the villa approach is by no means confined to the same style as the country mansion, with its extensive park, or grounds; indeed, it cannot be, neither extent nor local circumstances would warrant such a procedure. The park approach will, for the most part, wend its way through existing groups of huge timber trees, whilst the villa approach must, in the main, be supported by

groups of evergreens. There are several reasons why such should be the case, but the most cogent are the severe limitation of space, and the absolute necessity for a style of planting which will afford privacy and seclusion—such buildings being generally contiguous to towns or public roads. Having premised thus much, we will just glance at the park approach; this, however, does not concern the majority of our readers, and we shall speedily dismiss it.

The position of the entrance lodge, or gates, must be chiefly determined by convenience, such as the principal roads, railways, &c.; and it sometimes becomes necessary to have subordinate approaches as matters of convenience; these, however, are to be avoided, as tending to break in upon unity of expression and seclusion—two great principles never to be forgotten. The style of the lodges, gates, and their appendages, are generally dictated by the style of the mansion. This rule is, nevertheless, sometimes departed from when the approach is very long, and the locality of very peculiar character.

And now for the direction of the approach. It is a maxim with our best landscape gardeners to avoid all circuitous routes, unless fairly justified by the existence

of such objects as trees, sudden acclivities of ground, or other important interruptions; the whole line should appear, in fact, a common-sense affair, no departure without an obvious reason. We do not dispute the beauty of a bold course in preference to one so very tame that it looks like a would-be-straight line, attempted by a bungler; but all attempts this way should be made with extreme caution.

After entering the demesne, at, as near as can be obtained, a right angle, it may, generally, with the exception of a necessitous sweep or two, bend gradually towards the mansion, and should, by all means, if it can be contrived, ascend from the lodge: this gives an air of importance to the mansion, which a secondary line cannot impart. In its progress it should by no means pass any offices; this detracts sadly from the dignity of the whole. A well-conceived plan of mansion and approach, taken conjointly, will place the lodge entrance on the north side, or some point ranging between it and east or west; and, by this arrangement, the visitors obtain altogether fresh views of picked scenery from the drawing-room, and other principal windows, which are generally in the southern side. Good, bold vistas are, of course, not only admissible but desirable in the approach; but care must be taken that the first view of the mansion is at an imposing point, and that the approach is obviously tending towards it.

Such, in the main, are the principles applied to the approach; but it is evident that, since no two approaches can be exactly alike as to local circumstances, much modification of these principles must ever take place. There is nothing like being ruled by the natural impress of the place in these matters, at least, so far as not to infringe on leading principles. It is a common practice to throw the lodge gate into a deep recess; a plan that cannot be too highly commended, as imparting an air of dignity and freedom to the entrance, and thus giving it a degree of importance the more suburban villa cannot at all times command. One great fault we have frequently noticed—at least, such it appears to us—and that is, the want of a little more massiveness in the gates and appendages. It is certainly not a general fault, but one which deserves pointing to. Of course, such massiveness must bear a due relation to the bulk and style of the lodge, with its appendages, and the two jointly to the capacity of the interior, together with the mansion style. It need hardly be repeated here, that no portion of the dress grounds should be exhibited from the approach; such should be studiously concealed, for, could they be seen, it would at once lessen the interest that is ever felt by the stranger in guessing at what the hidden portions of the domain might be. Besides, the picture would be contradictory in itself—a jumble.

In speaking here of a considerable amount of what may be termed simplicity in the line of approach (or that feeling which is averse to affectation and laboured attempts at display, by means of manœuvres too artificial to be relished by persons of any pretensions to

taste), let it be observed, that where ground is of an undulated character, it is far better occasionally to bend to such natural features than pertinaciously to fight against them. To follow the latter whim expensive cuttings become necessary; nor is expense the whole of the evil, for, when accomplished, it may one day be discovered that higher principles and less expensive proceedings have been set aside by works, costly, yet defective.

It is almost needless to add, that a liberal breadth of turning road must be allowed at the entrance door of the mansion.

Avenues are imposing arrangements when the approach is flat, and the general tone of the place bears the stamp of art; they are dignified approaches, but should be attempted with some consideration. It has been well stated, by some of our great landscape writers, that they divide the landscape; or, in other words, however agreeable or dignified in themselves, they destroy unity of design. E.

It no longer admits of any doubt that the days of exhibition at our Poultry Shows must be reduced in number, and we think in no instance should those days exceed *two*. We say *must*, because we are quite sure that no Committees composed of gentlemen anxious for the continued prosperity of their Society, and still more so for safety of the valuable birds entrusted to their care, can, in defiance of the past year's experience, persist in the course they have pursued hitherto.

We have letters from many of the exhibitors, even from some of the most successful in taking prizes this year at Birmingham, all mourning over the condition of their birds which were there exhibited. One of those exhibitors, writing even as late as the 8th instant, more than three weeks since the termination of the Birmingham Show, says, "My birds went up last night to the Metropolitan Show, but my two Birmingham Spanish Cocks are both ill, *never having recovered that week*."

The Rev. T. Prater, writing from the neighbourhood of Bicester, says, "I am heartily glad to see your remarks respecting the time which specimens are kept confined at the various Poultry Shows. My birds sent to Birmingham, were, on the whole, confined ten days; and in one pen, purchased by me on the first day of the show, *one pullet died*. I hope you will not let the subject rest, as it is undoubted cruelty to the birds."

E. George, Esq., of the Rookery, Chaldon, Surrey, writes to us as follows:—

"In *THE COTTAGE GARDENER* of December 30, you state the highest price you know to have been given for Shanghae's, at the Birmingham Show, to be £25 for Mr. Punchard's pair, and £30 for four of Captain Hornby's. These would have been regarded as exorbitant prices a few months since, but a chicken, bred in March last, sold for a still higher price. A cockerel (in pen 381), entered as Miss George's, of Chaldon, Surrey, (it should have been Mrs. George) was purchased by Mr. T. H. Fox, of Snow Hill, Lon-

don, for £21; and only on condition that Mrs. George retained it till February to breed from.

"Now for the sequel, which with me, at least, is a fact that tells forcibly against the keeping Poultry confined in pens for so long a time, *that bird, although in perfect health when he left home, is since dead.* Fortunately for Mrs. G.'s credit, Mr. Fox had not taken him.

"May I here express a hope, and I believe it is that of most exhibitors, that the Metropolitan Show will, in future, be limited to a shorter duration. It will then, doubtless, possess attractions which none but a great Metropolitan Show can offer. As it is, many very choice birds will be 'born to blush unseen;' their owners preferring to keep them in modest retirement, rather than expose them to the gaze of admirers, and the risk of losing their beauty, health, and even life."

A clergyman in the South of England, who is sparing no expense in the endeavour to improve the breed of Shanghai Fowls, has thus written:—

"The manner in which you have lifted up your voice against two very great errors in the management of Poultry Exhibitions, entitles you to the praise of all, who, like myself, take a great interest in their success. They are errors of such magnitude that I am fearful that they will, unless remedied, be fatal to many a promising Association, and I therefore hope that you will not lose an opportunity of denouncing them as strongly as you have hitherto done. I need scarcely say, that I allude to the practice of appointing a dealer as judge, and to the length of time over which some of the leading shows extend.

"We all know what a common thing it is for a man to fancy his own stock vastly superior to that of his neighbour's, and, indeed, of almost every one besides. The dealer has, in the first place, this weakness to contend against. Again, he has to stand well with customers whom he has supplied, as well as to maintain his reputation with a view to his future orders—points, surely, which present temptations sufficient to disqualify any man for so responsible an office. I am quite sure that unless the practice be checked, the public will lose their confidence in the awards, and consequently their interest in the exhibitions.

"And now one word with regard to the number of days over which the leading exhibitions extend. Nothing can be more injudicious than this. There is a large and daily increasing number of fanciers, who would not mind sending some of their choice specimens for two or even three days, but whom all the prizes in the world would not tempt to submit their favourites to the wear and tear, and consequent injury of a seven days show. Indeed, we frequently see enough in one day to make us wish that we had never exhibited. How often may you hear a valuable bird addressed in some such words as these, "Get up you lazy brute," the speaker at the same time suiting the action to the word, and making no very gentle thrust with his umbrella or walking-stick at the poor creature's breast. I have reason to know that *some of our most eminent breeders complain most loudly; and that two or three of them have declared that unless an alteration is made they will not again exhibit.*

"It is alleged that the judges require much time to make their awards, and also, that the expenses are so heavy, that the Societies, for their own protection, are obliged to keep the birds longer than they could wish. Might not the first of these reasons be met by appointing many more judges? and I am quite sure that competent men in each class could easily be found, *if dealers were excluded.* And might not an appeal be made to exhibitors and lovers of poultry to increase their subscriptions, so as to make the Societies less dependent on the money taken at the doors? Many, I am sure, would gladly relinquish their prize-money, and many would readily double their subscriptions and entrance fees, if, by such a course, the shows could be shortened some two or three days."

N.

In confirmation of the statement made by our cor-

respondent, we can say that we know that Captain Hornby, Mr. Sturgeon, Mr. Punchard, Mr. Peck, and some other extensive poultry breeders, are ready to pledge themselves not to exhibit unless the number of days of exhibition are curtailed. The three last were missed at the Metropolitan Show, and we have Mr. Gilbert's permission to state that he is opposed to such a lengthened period of exhibition. This, to some extent, is an assurance that this reform will be effected in the next Show of the Metropolitan Society.

COVENT GARDEN.

WE are considerably gratified to find that our suggestions for the planting of fruit-trees in situations which are usually accorded to timber and ornamental trees have, in several instances which have come under our notice, met with high approval. The more the subject is studied, the more interesting it will become; and we have no doubt that in a few years, after the effect of such a system of planting has been properly appreciated, that it will become very general. There is, perhaps, no country in the world where the study and, consequently, the cultivation of fruits is more neglected than in our own. In America, they have in various states Pomological "Societies" and "Institutes," which meet as regularly as our Royal and Linnæan Societies, and discuss pomological subjects. Several excellent works on the subject have issued from the press of that country, and are justly popular; and it is to America that we are indebted for some of the finest varieties of fruits. Of these, we have the *Seckel*, and many other Pears; the *Jefferson*, *Washington*, *Lawrence*, and numerous first-rate Plums; many very excellent Cherries; and numerous other subjects which are not known in this country, simply because there is no taste for, and no encouragement given to, the science. In Germany, too, it is a very popular study, as the numerous pomological societies and publications furnish ample evidence of. In France, it has a great measure of support, although, perhaps, not so great as in those countries already mentioned; but certainly far greater than in our own. And in Belgium it is found not unworthy of government patronage and support. Need it be wondered, then, that so little is known, when so little interest is manifested on the subject in this country? We trust the time is coming when the same vitality and energy will be exhibited as there was at the time when Mr. Knight and Mr. Sabine devoted so much of their attention to it. This study requires only to be known to be more highly appreciated. We intend to devote some attention to it as opportunity offers. We do not mean as regards the cultivation and management of fruit trees, for that is already ably treated of in a separate portion of this Journal; but rather to consider the kinds, qualities, distinctions, and adaptations of the different varieties of fruit either already in cultivation, or which ought to be in cultivation in this country. The popular taste generally runs on a few old-fashioned sorts, regarding not those which are of more recent introduction, and

infinitely superior. There may be some excuse for this, there having been, of late years, so much disappointment experienced by false characters and recommendations accompanying new varieties, as to render cultivators credulous, and giving them reason to pause before they plant any varieties of which they have not some personal knowledge.

Next week we shall speak of such fruits as are adapted for planting against walls on different aspects and situations, and, in doing so, we shall treat more particularly of Pears. We have seen many instances where—in the north particularly—these can be cultivated with much greater advantage against walls than Peaches, Nectarines, or Apricots, and without one-half of the trouble or risk which attend these sorts of fruits.

During the week the trade of Covent Garden has been unusually dull, more so than it has been at this season before; and this is attributable entirely to the state of the weather. VEGETABLES have been very abundant. *Cabbages* and *Savoys* make from 10d. to 1s. per dozen. *Greens*, 2s. per dozen bunches. *Celery*, 6d. to 9d. per bundle. *Brocoli*, 6s. per dozen bunches. *Onions*, 2s. 6d. to 3s. per bushel. There is a good supply of forced *Rhubarb*, at 2s. per bundle. *Sea-kale*, 1s. to 1s. 6d. per basket of about ten stalks. Several parcels of *Asparagus* have also been offered, but it is very small and weak. *Potatoes* are a dull sale, but still maintain good prices—say from £5 to £7 per ton. In fruit we have nothing new, and the price continues the same—4s. to 6s. per bushel for kitchen APPLES, and 6s. to 10s. for dessert sorts. Of PEARS there is nothing new besides what were enumerated last week. *Flowers* and *Plants* are also of the same descriptions as we mentioned in our last report. H.

GOSSIP.

A SECOND edition of Mr. Rivers' pamphlet on *The Orchard House, or the Cultivation of Fruit Trees in Pots under Glass*, is just published. It contains an appendix, entitled "The Experience of 1852." In this appendix Mr. Rivers states that his orchard-house has fulfilled all his expectations. He warns those employing such a structure not to have vines trained against the roof, as the full unshaded light is one of the requisites for obtaining well-flavoured fruit; and we will conclude our notice of this work, which is so promotive of "glass for the million," with this extract:—

"With regard to air: as soon as peaches begin to colour, if the weather be hot and sultry, all the shutters should be kept open night and day; and if it be even cold and windy, they should be always partially open. I believe but few, very few, even good gardeners have the courage to give sufficient air to vinerias and other glass erections; so that grapes are often colourless and flavourless, owing more to the want of air than anything else. In one of my vinerias, the past season, I had a nice crop of Hambro' grapes. When they commenced to colour, mildew, as with many of my neighbours, made its appearance on a few bunches. All the shutters, back and front—it must be recollected that I have no sliding lights; all my roofs are fixed, and air given, back and front; the old-fashioned lights, slid down as usual, would admit rain—were immediately opened, and kept open,

night and day, till the grapes were ripe. They were then closed at night, and opened in hot sunshine, so as to keep the house airy, warm, and dry. The grapes were perfect in colour and flavour, and their skins were so tender as to nearly melt in the mouth. No fire-heat was employed; all was done by sun and air.

"In the orchard-house culture of peaches and nectarines syringing must play an important part; for the red spider is so fond of their leaves, that, like Sindbad's Old Man of the Sea, he will stick closely, and cannot be dislodged without applying the syringe close to the under surface of the leaves. If this pest be suffered to make the least progress, the flavour of the fruit will be entirely destroyed. A small microscope, in the hands of the amateur, will be the best instrument to discern it; looking closely at the under surface of the leaves, if it be there, a small bright red speck, like a red grain of sand, will be seen. The experienced gardener does not look for them. One glance at the upper surface of those leaves, which show some minute yellowish specks, is quite enough for him. If, therefore, the least sign be apparent, continue the regular syringing, even till the fruit is ripe; otherwise, syringing may be discontinued when the peaches and nectarines commence to soften, preparatory to ripening.

"Trees that have been from four to seven years in pots will require water daily in summer, as the pots become full of roots, and absorb a large quantity of water. Lifting the trees more than once during the summer, as mentioned in the treatment of those at Hyde Hall, will be found quite necessary. They become by this treatment sturdy as oaks. Those at Hyde Hall, adverted to below, are at this moment (November, 1852) the most robust and fruitful bushes I ever saw.

"I was reminded of my orchard-house trees in a recent visit to Versailles. I there saw, as I daresay many of my readers also have seen, hundreds of orange trees centuries old, kept in tubs, and confined to a very small quantity of earth as compared with their bulk, and not shifted for many many years; they are all in full health and vigour. How are they nourished? Simply by top-dressings annually of manure, and occasionally liquid manure. If, then, an orange tree can be thus kept in health and vigour in a tub for centuries, surely a peach tree, in a pot, receiving nourishment above and below, can be sustained so as to give fruit for ten or twelve years. This is mentioned because I once heard a really clever gardener say, "Oh, it is impossible to keep trees in health in pots!"

"I have found from the experience of the past season that peaches, nectarines, figs, and grapes, will not ripen in those houses, with hedges for walls, referred to in page 9. Apricots, plums, cherries, and pears will succeed well; the three latter even better than in houses with walls either of wood or brick."

The first week of the month included two sales of very superior *Shanghai fowls*. On the 4th, Mr. Stevens disposed of Mr. Punchard's superfluous cockerels and pullets, amounting to 183 birds, which were sold in 170 lots, realising just over £488. The highest price given for a cockerel was £10 10s.; and the highest for a pullet £7 7s. The sale was very numerously attended by amateurs as well as dealers, from Bristol, Birmingham, Yarmouth, and elsewhere. The healthy and good condition of the birds was the subject of general remark.

The other sale, January 5th, was of Mrs. Herbert's *White, Buff, and Black Shanghaes*. These were sold by Mr. Strafford.

Mrs. Herbert has sold privately, before she thought of a sale, nearly £300 of birds. One pullet she sold for £20, or guineas. Had she fortunately kept those, and not put so low a figure on her other pen at Birmingham, which was immediately sold for 20 guineas, the sale would have been still more extraordinary. There were 110 birds, and they realized £369 4s. 6d.

The white birds (much the best specimens) averaged £3 18s. 9d. each; the Buffs, an indifferent lot, £1 3s. 10d.; and the Blacks, £3 5s. 6d. Mr. Stafford's arrangements were excellent.

It is determined to have this year a *Cheltenham Summer Exhibition of Poultry*, and the days fixed upon are the 1st and 2nd of June. The secretaries are Messrs. Jessop, Brothers, Nurserymen and Poultry Fanciers, Cheltenham.

We are very glad to be informed that the government of Belgium have appointed commissioners to obtain reliable evidence as to the merits and best modes of cultivating the various species of *fruits and their varieties*. The commissioners are eight Belgian gentlemen, but corresponding members in other countries are connected with them; those for England being Mr. Rivers, of Sawbridgeworth, and Mr. R. Thompson, of the Horticultural Society's Garden at Chiswick. The results of their inquiries are to appear in parts, at an annual charge of 24 or 36 francs, according to the quality of the paper, &c. Each part is to contain four coloured plates, and the requisite amount of description and detail. It holds out a promise of settling many disputed points in fruit-culture, and removing a mass of misapprehension by determining synonyms.

As the present winter, by its wetness, has absolutely prevented *Wheat-sowing* in many districts, it deserves notice that *Talavera Wheat* has for many years been sown in the midland and southern districts of England as late as the end of February, and the produce well housed in September. It yields quite as good an average of grain as any other variety, and more flour is obtained from it than from most other varieties.

We have recently met with a very amusing and intelligent little volume, entitled *Walks after Wild Flowers*, by Richard Dowden. The following extract, giving the derivation of the word *Mustard*, is by no means the only spicy specimen we could give from its pages:—

"*Mustum ardens* is 'burning hot vinegar.' There was always in the world's surgical practice some method of counter-irritation; St. John Long's proceedings were not an original idolatry, but an aggravated revival of ancient practices, for we find that there was an old cure made with boiling vinegar, or wine—for both were called *must*—and adding to these the powder of *sinapis* made the *mustum ardens*. It was applied as a cataplasm when boiling hot, and it was often a cure, no doubt; but at times its only effect was to 'scand poor wretches.' This eschariotic was, in a milder form, diverted from the outside to the inside of the body, and was taken by flapdragon-drinkers, and other fire-eaters, as a dram; of course the vinegar decreased, and the wine and ardent spirits increased, in this *mustum ardens*. At length, however, it settled down into our table mustard, and was eaten, as Tusser tells us, with everything:

'Brawn, pudding, and souse,
And good mustard with all.'

To this day some housekeepers make their mustard with vinegar; and the common dressing for cold and watery salads—the *salso-acid* of old cookery—is mustard, salt, and vinegar."

The following is a list of the *Poultry Shows* of which we are at present aware. We shall be obliged by any

of our readers sending us additions to the list, and giving the address of the Secretaries.

DONCASTER, January 21st. (Sec. H. Moore, Esq.)

REIGATE, February 1st and 2nd. (Sec. J. Richardson, Esq.)

GENERAL PRINCIPLES OF FORCING.

It may seem strange to those unacquainted with forcing matters to think of taking at one swoop, Vines, Peaches, and other forcing fruits, and dealing out advice applicable to them all. Yet, a little generalising is not amiss now and then, for it will assist the novice in so grouping his matters as to economise in regard of both fuel and labour, as well as to fix in his mind, in distinct characters, the necessity of observing certain laws, which at all times affect the well being of fruits under the forcing process.

Now, the great principle which, under trifling modifications, concern all forcing, are the following:—Light, Heat, Atmospheric Moisture, and Ventilation. These are placed purposely in a just sequence, according to our ideas; for a due amount of light justifies the application of heat in the forcing sense of that term; this done, a necessity arises for a given amount of atmospheric moisture; and as this kind of artificial excitement continues, a slight contamination or vitiation of the enclosed air of the forcing-house takes place; hence the necessity for ventilation, which, in the main, may be said to be caused by heat, and this brings all the rest into action. This is manifest from the fact, that cold frames, or pits, in winter, if dry, may remain closed for days without injury.

Light, then, would appear to be the chief mover of the whole affair, as concerns the forcing gardener; and we will point to its bearing in practice. To light it is we owe, in the main, the necessary solidification, or ripening, of the parts of our plants or trees; in other words, the maturing of their structure; also, the digestion of the sap; and lastly, the colouring matter is almost entirely dependent on the light, as witness the process of blanching, which takes place in our Sea-kale, Mushrooms, Asparagus, &c., when purposely deprived of light. If this, then, be the prime moving power of the forcer's machinery, how essential is it that the gardening student's mind should be duly impressed with its importance in the very outset of his practice. It may here very naturally be asked, what is to be done practically, since we cannot make light? True enough, indeed, or man would soon disturb the order of the seasons. But some things the forcer *can do*; in the first place, secure clean glass to his structures; in the second, objects requiring a great amount of light placed very near the glass; and thirdly, a negative bearing of the subject—he can reduce the stimulus of heat in the comparative absence of light. Added to this, he can, by training and thinning processes, secure that what leaves are retained may get the full influence of the light.

And now for *Heat*; for without this, in a certain ratio, all the light imaginable would be inadequate to the purposes of vegetation. Of course, this is a matter of degree; we speak of it here in reference to its power of exciting vegetation; and in order to accomplish this, it must, in the main, be above the freezing point, even with respect to plants from our coldest mountains. As to the forcing gardener's subjects, there are few will be excited by warmth in any very sensible degree, until the thermometer has attained the point known as "temperate," or 55°. However, the application and increase of heat practically requires much consideration. To theorise on heat is not enough; a man should be thoroughly conversant with the habits of his subject in

their native conditions; this, added to a scientific consideration of the properties of heat, constitutes any man a first-rate forcer, provided he has the proper means to carry out his views. This be the maxim, then, with young forcers; in no case use extra appliances of heat irrespective of the amount of light. As for night-heats in our forcing-houses, we are persuaded that a diminished amount, generally speaking, would be beneficial.

Orchids are said to be tender things. We have a house containing both eastern and western genera, the temperature by night of which, for the last three weeks, has not averaged above 50°, and yet the plants look hearty, or rather robust. But they have had a roof-covering nightly, and thus very slow firing sufficed. This question of roof-covering has a kindred bearing on this portion of our remarks; we have little doubt the time will arrive when they will, on all sides, be deemed a necessary appendage of glazed structures; indeed, their utility is already recognised by most of our first-rate gardeners, the only thing that remains is to provide a material of general application.

Atmospheric Moisture is our next consideration; and the very mention of this brings to our mind the mummy plants of our childhood, when crowded shelves of half-dried specimen plants might be seen in first-rate establishments, the red spider, mealy bug, &c., rejoicing in a congenial element, and, doubtless, marvelling at finding that so far from their native home, foreigners of Man should share such amazing sympathies for their sustenance and preservation. In those fine old days there was none of your gimcrack dished-tiles, flanged-pipes, and evaporating-pans; these are all innovations; floors were white, walls were dry, and not a dew-drop or a pearly spangle to be seen! The hothouse would have made a capital bed-room; however, the spiders and the bugs have the worst of it now, scarcely a soul can be found to patronise them.

Joking aside, these were serious matters; humanity is a fine thing, and so is sympathy; but in these days it begins at home. How they managed in those days to please the cook and the table-decker, it is now difficult to imagine. But how altered! Now, where is the hothouse of any repute that has a heating apparatus without a provision for atmospheric moisture? To come, however, to principles—without a due amount of this necessary element, the tax on the foliage of plants, in the form of perspiration, is too great at times to enable the plant, or tree, to present that degree of vigour which is at once the testimony of robust health, and the precursor of fruit or flowers. If any one cannot comprehend this, let him read of the parched wilds of Africa; or, indeed, come nearer home, and enquire why Britain boasts so of her green fields and lawns, as compared with some of our continental neighbours. A too high degree of evaporation, without a corresponding degree of absorption by the foliage, necessarily tends to that condition, which may be termed, in a mild way, leanness; and, however it happen, is the very condition to prepare for the various insects which are the pests of vegetation, whether fruits or flowers.

Every structure, therefore, of whatever character, appointed to gardening matters, should possess a special arrangement for the production of atmospheric moisture: we would scarcely except our succulent tribes. Let it not be understood, however, that we would have our readers for ever tampering with damp atmospheres; whilst we thus write, we must deprecate any rule without a principle. Even with the orchideous tribes, which revel in a warm and moist air, there are periods when even an almost dry atmosphere is beneficial for a few hours.

After all this sifting of principles, let us take a little fresh air; let us think about *ventilation*—that principle

so averse to what the gardener terms “drawing;” for a drawn or over-lengthened plant is a sure evidence of mismanagement—of a debilitated constitution.

We remember well the time when men of scientific attainments fancied that practical men were altogether wrong about this giving of air, ventilation, or whatever else folks call it. But they were wrong: the practical men had, no doubt, been occasionally guilty of a sort of mannerism; but from this even what class of society is totally exempt? It assuredly is not worth while to open the sashes of a greenhouse to a tempest, or to what country-folk call a thin wind; but these are merely extravagancies. We say, ever endeavour to obtain a circulation in the confined, and, by consequence, stagnant air of your garden structures; if you *must err*, let it be on the right side of nature. The great and marvellous world which we at present inhabit has, thanks to God, neither roof nor sides like a hothouse; and though the poor, untaught heathen may fancy a boundary in the ethereal blue overhead, we are assured that such bears the stamp of infinity.

After all this, let us caution our readers against the abuse of this principle. Giving air, and giving artificial heat, are each matters to be continually modified by existing circumstances; and such things make the life of a gardener one of continual watchfulness. It has been said that you can tell a gardener—a genuine “early York”—a mile off; so be it: so you may a ship captain, a lawyer, a chimney-sweep, and some other grades of society.

Our early cucumber man would, if he grow little else, doubtless, speedily condemn us as horticultural latitudinarians. What! he may say, let a north-easter blow on the first ridged plants in the end of February? We say no, by no means; and are aware that such a free advocacy of ventilation may, indeed, subject us to a little prejudice. This should not be.

To sum up the matter; light, heat, atmospheric moisture, and ventilation, are all powerful means to either good or bad ends in the hands of the cultivator. If he make an indiscreet use of them, that is, uses them irrespective of outward conditions, the fault is not ours. Here is the Scylla, there Charybdis, pray do not run your vessel against either.

R. ERRINGTON.

BULBS.

(Continued from page 215.)

BULBINE.—This is a very old-fashioned class of plants, which were very much sought after when the rage for herbaceous plants, or, indeed, any class of plants which promised a long array of hard names, was at its height; flowers were very little thought of then in comparison to the numerical strength of a “collection.” The future historian of our days will have to record that we began to run into the opposite extreme early in the nineteenth century, and that we discarded a host of beautiful plants for no other reason than that we could not manage them, for *bedding out*, or for *specimens* for flower-beds, or the exhibition tables, until towards the middle of the century we began to perceive that the improvement of races could be pushed beyond the province of the mere florist. Even then, however, I fear we shall not have left much to raise the character of *Bulbines* or *Bulbinellas*. The only difference between *Bulbines* and *Anthericum* is in the colour of the flowers, the former being yellow or yellowish, and the others white. On account of the succulency of their leaves, they might be supposed to be *Asphodels*, but all of them are true *Anthericums*, and they require the same treatment, to be planted on a warm dry border of light sandy-soil, and to be slightly protected in winter, which

is easily done, as the stalks and most of the leaves die down in the autumn. They are now very scarce, and can hardly be met with out of Botanic-gardens. It is on record, that a great number of them were lost in the hard winter of 1740, which were never introduced a second time. I never saw but three or four kinds of them, and that many years ago. They are not bulbs, but tuberous-rooted.

CALLIPHRURIA HARTWEGIANA.—This is a handsome flower that has never been figured yet. It was "sent out," eight or nine years ago, by the Horticultural Society, who had it from Hartweg. It was discovered by him at a place called Guaduas, in New Grenada. Dr. Herbert called it *Hartwegiana*, and described it in the Botanical Register for December, 1844, from specimens sent to him from the Society's garden, where it flowered for the first time in March, 1844, along with the leaves. The flowers are green and white, and seven in the umbel or flower-head; the tube of the flower is greenish, and its lobes white, tinged with blush. The leaves are *petiolated*, that is, broad above and tapering so much at the bottom as to become a footstalk, like a *Funkia*-leaf. It seems to be related to *Griffinia*, and to be treated exactly like the more hardy *Hippeastrums*, requiring strong loam, good stove heat after the flowers are over, so as to get the leaves ripened well before they die down. Naturally, it seems a winter grower, but it is not positively so, like *Amaryllis*. It can be made to grow and go to rest, just like a *Hippeastrum*, either in May or September, or, by degrees, it would begin to grow at almost any season. There have been many mistakes about this fine bulb. There are two plants in cultivation very different from each other, called *Hartwegii* and *Herbertii*. These two names are in the Botanical Register. The first and true name is in the body of the work, and *Herbertii* in the index; but there is only one bulb yet known in the genus. Dr. Herbert spells it *Caliphruria* (from *Kalos*), but in the "Vegetable Kingdom" it is *Calliphruria*, which we followed in the Dictionary. The bulbs increase readily by side off-sets.

CALOCHORTUS.—This is a genus of very beautiful bulbs, found on the north-west coast of North America, and on to California. It was named by Pursh, a Prussian botanist, who travelled in North America, and wrote a book on the plants he collected. The unfortunate Douglas was the next traveller who met with them, and he sent or brought over quantities of flowering bulbs of them to the Horticultural Society, by whom they were largely distributed to the Fellows. He also wrote a paper on the genus, which was read before the Society, and printed in their Transactions in 1828 (*Hort. Soc. Trans.*, vol. vii.). They are hardy, or all but hardy, and are true Lilyworts, occupying an intermediate position between the wild Tulips and the Fritillarias. The bulbs are solid, the leaves are strongly nerved, and the flowers of some of the species are large and very handsome. The southern limit of the race is in California, where they dwindle into mere dwarfs, and self-coloured flowers, such as the little yellow one which Hartweg met with in the valley of the Sacramento, and which is now in cultivation; but in his Journal he speaks of another of them, which he found in April, or early in May, but not just in flower. It was high up in the mountains, and not far from the snow, then melting down and watering the soil, where this *Calochortus* was in fine leaf. The last conversation I had with Mr. Hartweg was about this very bulb, and the whole genus, to see if I could trace out the cause why these beautiful bulbs had disappeared from cultivation. I flowered three of the best of them in pots, and while in the dry state; after that they died without any apparent cause. It was just the same all over the country, as far as I could learn; but I heard afterwards that Mr. Groom, the great bulb-grower of Clapham, has succeeded with

them. Mr. Hartweg believes that none of them, but especially those discovered by Douglas in Oregon, or Colombia, should be grown in pots, but in peat borders, where they would be neither too wet nor too dry. My own opinion of them is, that we did not allow them sufficient time to ripen the leaves and bulbs, after flowering; that they are rather of the nature of *Tigridia* bulbs, and, like them, take a long time to ripen in our cold soil, and that, without being thoroughly ripe before they are allowed to go to rest, they will perish. Hartweg says, the little California species stand intense heat, and look perfectly green in the leaf after all the rest of the small herbage in these parts is scorched up.

CALOCHORTUS MACROCARPUS (Large-fruited) is one of the finest we know of them—a large, wide, open flower, chiefly of a rich purple colour.

CALOCHORTUS VENUSTUS is, perhaps, the next best of them. Its flowers are as large as those of *macrocarpus*; pure white in the upper parts, but the lower parts are clear creamy-yellow, and streaked with deep red marks, with a conspicuous spot at the bottom of each petal resembling a drop of blood. Altogether it is a charming flower.

CALOCHORTUS SPLENDENS.—Equally beautiful, and more resembling *macrocarpus* than the last, being of a lilacy-purple, and having a small dark spot at the base of the petals.

CALOCHORTUS LUTEUS.—This is a Californian species, where it was found both by Douglas and Hartweg; and it flowers later with us than the rest—in September and October. The three sepals are green, and narrower than the petals; the latter are yellow at the points, and green below. In the middle is a yellow band of hairs, among which are seen deep spots of blood colour.

CALOCHORTUS NITIDUS (Showy).—This is a much smaller species than any of the rest, but we know little about it, except from Douglas's account of it in the Transactions of the Society already alluded to. The flowers are chiefly purplish. Douglas heard of another species, "a magnificent plant," growing about the "confluence of Oakenagen River," where the roots are gathered by the wild Indians, cooked, and devoured as they do their "quamash" roots (*Camassia esculenta*), another bulb belonging to a kindred section of the order.

CALOCHORTUS PALLIDUS.—This is a very small plant, a native of temperate regions in Mexico, whence it was introduced to Belgium in 1844. The flowers are pale yellow, on comparatively long footstalks, three or four of them forming the umbel. They appear at the end of summer, and, like all the family, the bulb goes to rest in the autumn. It will be in keeping with an allied genus called *Cyclobothra*.

CALOCHORTUS ELEGANS.—This is the *Chalochortus* of Pursh and Douglas, and the *Fritillaria barbata* of Kunth, also of our Dictionary, which is wrong, for it belongs to a kindred genus named by Sweet, which includes, as we shall soon see, several pretty little *Calochortus*-like flowers; but they all droop, or have nodding flowers, as the botanists say.

CALOSCORDIUM NERINEFLORUM.—This is a very dwarf bulb from China, with the leaves and habit of an *Allium*, and the flowers of the same purplish or pinky hue as the Guernsey Lily. It is hardy, or all but hardy, but so apt to be overlooked, if planted out by the side of an open border, that it is best to keep it always in a small pit, in any light sandy soil. *Hesperoscordium* is another form which these little garlic-like bulbs assume on the opposite shores of the Pacific, in the far west, and of which we shall remark when we get round to them.

CALLITHAUMA.—We missed this extraordinary genus of Peruvian bulbs in our Dictionary. But three distinct species of it were introduced to this country; the first, called *spathulatum*, by Richard Harris, Esq., of Liver-

pool; and the other two, *viridiflorum* and *angustifolium*, by Dr. Herbert, with whom they flowered in 1840-41; and there are figures of them in the Botanical Magazine (April, 1841). Ruiz and Pavon found *C. viridiflorum* plentiful in the woods of Huassahuassi, and in stony places of Palca, in Peru. They called it *Panocratium viridiflorum* in the "Flora Peruviana," having an enormous cup inside the flower. They represent the scape of this bulb six feet high, bearing four or five large flowers, "beautiful, entirely emerald green." Ruiz's dried specimens of "this marvellous plant" were lost by shipwreck. Those that flowered at Spofforth were only of ordinary size, and the narrow-leaved one seemed to be only a variety of the other; both of them green-flowered.

C. spatulatum was gathered some hundreds of miles from Truxillo, in Peru. It seemed to like more heat than the others. The flowers of this species are green also, but it never flowered in England, and few could grow it except Dr. Herbert, who found it to thrive best in loam. The genus seems intermediate between *Ismene* and *Coburghia*. Dr. Lindley considers it a true *Ismene*; in fact, a green Peruvian Daffodil, which is not far from the mark.

Any of our young readers who would be content with a great name and a little fortune, have only to procure specimens of all the Pancratiform-Amaryllids that I hope to touch upon in this series, grow them as I shall say, and cross them diligently until they disclose their real affinities, and fill our borders with the gayest flowers in the country.

Let us now see what *Panocratium*-like, or Pancratiform *alias* Pancratioid, means, having thus incidentally mentioned the word. One who knew as much about one flower as another, could see no difference between a Lily and an Amaryllis; and there is a kind of Lily and a kind of Amaryllis, which, if a flower of each was gathered, and the "private mark" kept out of sight, there is not a man on earth who could tell, with certainty, which was the Lily, or which the Amaryllis; yet, by showing the *private mark*, a child could learn in two minutes to know any Lily from any Amaryllis, in any part of the world. The private mark is, that in all the lilyworts, the seed-pod is in the inside of the flower, at the bottom, as in the tulip. The Amaryllids have the seed-pod always on the outside of the flower, like a Fuchsia. In *Fuchsia microphylla*, the opening of the flower is only an eighth-of-an-inch from the end of the seed-pod or berry, whereas the opening of the flower of *Fuchsia corymbiflora* is four or five inches from the berry, and so it is with flowers of the Amaryllids; some have long tubes to the flowers. I shall mention one whose tube is more than ten inches long, and some have hardly any tube, and the rest have tubes of different lengths; still, it is easily seen whether the seeds are to be inside the flower or outside; and so, if it is a Lily or an Amaryllid. Now, besides this mark of distinction, the flowers of an Amaryllid take after three particular forms, each of which is as easy to know as the berry or pod-mark. The first form is called after the Daffodil, *Narcissiform*. A single Daffodil looks as if two flowers were grown into one; the inside one is called the cup, or coronet, and in olden times, the nectarium. This inside cup diminishes, in different kinds, until all that can be seen of it is a mere ring at the bottom; but whatever the length or the size of the cup, all the plants in the section have their stamens growing inside the cup, and *free from it*, so that you could cut away the flower and the cup without hurting the stamens. Every bulb in the world, with a cup inside the flower, or the mere rudiments of a cup, and having the stamens free from the cup, belongs to this Daffodil section. There never was a more simple thing to learn than this, except the next great section of Amaryllids, which also has a

cup inside the flower; and here, likewise, the cup takes different forms and sizes in different kinds, but still there is a cup, and to the inside of this cup all the stamens are fastened the whole way up, and at regular distances all round the flower. If you were to split a flower of this kind the stamens must come with it, and if you now tear off the flower itself, and keep the cup with its six stamens (they are almost always six), the thing would look like the foot of a duck, the stamens representing the toes, and the cup the web part of the foot. Then what is to hinder any one, who can distinguish a duck's foot from the hoof of an ass, from knowing to which of these two sections a flower belongs as soon as he sees it? This hoof is the same as the cup without the stamens, and the web-foot the cup with the stamens; the hoof is the Daffodil section, and the web-foot the *Panocratium* section. But the third and last section is even more simple than these two, for there is no cup at all; nothing but the outside flower (perianth) and the stamens, with the seed-pod outside the flower, as in the Fuchsia. This is called the *Amaryllis-form* section. All the bulbs in existence, if the seed-pod is on the outside of the flower, must belong to one of these three great divisions. Therefore it is most essential for young people "to learn this by heart." If the English people, who went over first to Peru, were to know these three simple things, or even two of them, they would have never fallen into such a glaring mistake as to call *Ismene*, the Peruvian Daffodil, because *Ismene* has the stamens joined to the cup, and a large cup it is too, and very wide in the mouth, so that they could see the difference with one eye. In these days, however, people would not be let off so easily; and in a few more years, if the world keeps going round so fast as it does now, depend upon it that any one going to a strange place, who could not explain, or talk about the simplest elements of the principal branches of Natural History, he or she would be set down as of low breeding, and would be talked of all over the place in more ways than one. Let us, therefore, this very season, begin with the Snowdrops, and not rest satisfied until we can tell the orders to which every bulb belongs which comes in our way in flower.

D. BEATON.

HARDY STOVE PLANTS, THAT WILL DECORATE A WARM GREENHOUSE IN WINTER AND SPRING.

MANY of our subscribers have a small house, near their mansion, appropriated to plants, and which, for the purpose of securing winter bloom, and their own personal comfort, they kept at a temperature at night ranging from 45° to 50°, with an increase of 10° or 15° during the day, when a bright sun shines. Many, besides this desideratum, even if not possessed of a regular plant-stove, have a forcing-house, hotbeds, or pits, where, with a little scheming, a higher temperature can be obtained, in spring and autumn, than in a greenhouse where a general collection is growing and blooming. To suit their case, so far as to enable them to have the greatest quantity of bloom in one place, will be the aim of the present paper, even though we should be obliged to refer to plants that have hitherto received rather marked attention from us.

Though a high temperature and a moist atmosphere are essential to the growth of most plants from warm latitudes, it is a mistake to suppose that they can only be seen in bloom under similar circumstances. Many of them may be so managed as to induce them to bloom in summer; and then, while some require house treatment, many others will bloom freely out-of-doors. Others that will *not* bloom in winter, will stand longer in such a house as I have indicated

above than in a plant-stove; while the gardener will be saved all outcry about the *heat*. I often used to think that there was a little of the fabulous in this horror of the *heat* in our forcing and plant-houses; because, when I have found ladies and gentlemen starting back at the door, and refusing to enter a plant-house in winter, with a temperature little above 60°, I have seen them enjoying themselves in their own rooms, the fires in which had raised the temperature from 65° to 70°. I have no doubt, however, *now*, that the extra humidity in the plant-houses at a high temperature was what rendered them distressing to lungs that had been accustomed to air too thoroughly dried. Such a house, with an average night temperature a little below 50°, will suit a great many tender plants in bloom; while the house itself would constitute a happy and healthy medium between the saturated atmosphere of the forcing-house, and the baked, oven-dried air of the sitting-room.

Begonia obliqua.—Were I confined to two species of this genus for greenhouse use, I would select my favourite, though rough-looking, *Evansiana*, for summer, and *obliqua* for winter. In a house, with an average night temperature from 45° to 48°, I generally have abundance of its pretty pink flowers for three or four months in winter and spring. It is the hardiest winter-flowering kind that I know. Loam and peat will grow it admirably. Cuttings may be placed in a slight hotbed in April, and if encouraged will make nice little blooming plants for the winter following. Old plants may be pruned a little, and tied out in May, receive a shift if necessary, and be kept rather close in a cold pit to encourage growth, or placed in a peach-house or vinery; they will want more air and light in summer; near the glass in a pit, with the sash tilted back and front, until the middle of September, will suit it. From thence to the end of October, the pit should be kept closer and warmer; and by the beginning of November it should be taken to the warmest part of the greenhouse.

Begonia manicata.—This delightful, graceful plant is more tender. The whole of the summer treatment may be the same as for *obliqua*; but as it does not show bloom so soon, it will require an average night temperature of 55° from November to Christmas, to bring up the flower-stems freely and luxuriantly. When the flowers begin to open it will be quite at-home in the warm greenhouse, and will bloom much longer than in a stove, while the individual flowers will open better. No one who has once seen this in its beauty would like to be without it.

Begonia fragrans (M'Intosh's).—I have not yet tried this new kind in this manner, but it seems as if it would be hardy enough for this purpose. I introduce it here, because I am not aware that it has been previously noticed. I know little more of its antecedents than that it was raised at Dalkeith Gardens. Mr. M'Intosh, in addition to great and many kind courtesies, gave some cuttings to a friend, who transmitted them to me in a tin case last spring. Every cutting grew. The plants were kept in a hotbed during the first part of the summer, and then were exposed to more air afterwards, until they were housed in November. They are nice stubby plants, have been in bloom nearly two months, and look as if they would continue ever so long. The habit seems good; the foliage is somewhat fleshy, like *nitida*, but not nearly so large. The flowers are white, somewhat resembling the old *alba sanguinea*, but much larger in the individual blooms, as well as in the bunch; but the best remains to be told. In such dull weather as we have had it is slightly fragrant; but when the sky is very clear, or the sun is shining bright, its scent is *delicious*. A plant throws its aroma over the whole of a small house. I do not recollect any other *Begonia* that is thus scented. For this property alone it is a desirable acquisition. It would answer well as a warm-

room plant for several weeks. If not in the trade, it is to be hoped that the worthy raiser will take means for its more general diffusion.

Justicia speciosa.—This is almost the only one of the family that will thrive in such a situation in winter. The purple flowers are small and ragged, but a nice bush of it has a pleasing effect. Plants should seldom be kept above two years. Loam and peat will grow it well. Cuttings inserted in sandy soil, under a bell-glass in April, and placed in a hotbed, and potted as soon as struck, kept first in a hotbed, then in a cold pit during summer, or plunged out-of-doors in a sheltered place, will yield nice stubby plants by October, when they should receive a drier and warmer atmosphere to bring them into bloom. They will be gay in such a house from November to the middle of January. Plants that have bloomed one year, may be cut freely back at the end of March, have a little heat to break them, then fresh pot, and after keeping close for a few weeks, an airy cold pit will suit them in summer, keeping them closer and drier again at the end of autumn to cause them to bloom freely.

Gesnera elongata.—This, in such a house, makes no bad successor to the more striking *Gesnera zebrina*. The leaves are long and narrow, and though the scarlet flowers are short, they are produced in great abundance. This should have more peat than loam. Nice little blooming plants may be obtained from cuttings struck in a hotbed in spring, in sandy-soil, but without a close bell-glass, potted and kept in heat, and inured to more air, and free exposure in autumn. But two or three year old plants make the most interesting specimens; though they make a fleshy axis of growth at times, this is not to be depended on, like a corm or tuber. When flowering is finished, or early in spring, say in March or April, cut the plant down to within six or eight inches of the surface of the soil; let it stand rather dry, in a warmish place, until the young shoots are coming freely away, (often the young shoots will be found ready to your hand before you cut down the old flowering shoots) shake away a good portion of the old soil, prune the roots a little, replace in a similar sized pot, give a temperature of from 60° to 65°, if a little bottom-heat, all the better; give another shift when necessary, and keep closeish afterwards; by the middle of June transfer them to a pit or house, free from fermenting matter, where you can keep in the sun heat, and syringe over head; give air freely in August, and expose rather freely in September, and a drier air in the end of October will cause the flowers to come freely. With less trouble than is required for a good Cockscomb, you will thus obtain flowering plants for three or four months of the gloomiest season of the year.

Torenia Asiatica.—Some enquiries have been made about this lovely plant. The best specimen I have ever seen of this bloomed in spring and summer, after being saved in such a greenhouse during winter, when previously grown to a good size. Such a house will *not* be sufficient to keep it in a healthy, blooming condition during winter. Few things are more beautiful in clear weather in winter, but it will require a night temperature of from 55° to 60°, and even a little more in mild weather. I tried a beautiful plant the beginning of this winter, but the temperature having got several times below 55°, I was obliged to remove it in a fortnight. Under the most favourable circumstances, it would require to be transferred back again to the stove in a fortnight. In such a heated house few things are more splendid in winter. Plants for this purpose should be grown from cuttings struck in spring. Plants to bloom in greenhouses and glass-cases in summer should be struck the previous season. Old plants kept rather dry, and in small pots, will pass the winter, if the temperature is not below 45°, and will break and make fine

plants next season; but at that temperature they look as woe-begone, to the lovers of luxuriance, as Harry Moore's scarlet geraniums would do.

Eranthemum pulchellum.—This is admired for its beautiful blue flowers. I have used it for many years for such a house. It requires just a little more heat in summer than the *Justicia spectiosa*. The habit is naturally so good, it is almost impossible to make a leggy plant of it. Plants in such a house, and in a small plant-stove, have done equally well, and are now nearly done for the season.

Eranthemum nervosum.—This seems merely a variety of the last; but it is much dwarfer, and the leaves are smaller. The backs of the leaves are generally warted, which the uninitiated world mistake for disease.

Euphorbia Jacquiniaeflora.—This will answer for a couple of months after the plants come into bloom. Plants from cuttings do little good the first year, even though you give them hotbed treatment the most of the summer. Old plants that produce stiff, long shoots after being pruned in spring, give the best results, and bear rougher treatment in summer. Cuttings must be allowed to dry before being inserted. Peat, a little loam, and a portion of broken bricks and lime rubbish will grow these plants well. Old plants may stand under shade when growing in the early part of summer; but they must have full exposure to light, and a fair portion of air in autumn. I have just noticed that this splendid gem is not in our Dictionary by the above name, but I presume it is identical with *fulgens*.

Poinsettia pulcherrima.—This, with its large crimson bracts, will make such a house a blaze from the middle of November to the middle of January. Cuttings of the old flowering-stems, six or eight inches long, dried on a shady dry shelf for eight days after being cut, and then inserted in sandy, open soil in a hotbed, will make nice little plants, with several shoots, each of which will be terminated with its blazer in winter; but two or three-year-old plants yield the finest heads. Prune back within two or three inches of the older wood in March or April, so as to leave as many buds as you wish shoots—from three to eight may be considered a fair number. If one or two start with too much of a lead, stop them, so as to equalise the strength; but never stop after the first of June, or for your pains you will get shoots without flowers, or very small ones indeed. When fairly started, shift or top-dress. A cold pit, when you can give air, and keep close at will, will do for them after June. Manure waterings, in the warmest season, may be given freely. Everything that encourages strong, vigorous shoots, will also encourage large heads of dazzling crimson. To cause these to form, water should be minimised in October. I stated the other week that I had no experience with the white variety. Soil: Loam and peat, with lime rubbish, and top-dressings in summer of cow-dung.

But now a friend says, "All very well, but with my one house for display, even though I have all the conveniences of which you speak, how am I to grow in that house such hardy things as you have lately been alluding to—some pet Cinerarias and Geraniums, &c.—and then flare up with such blazers as these?" All easy enough. Suppose you can command most heat in the centre of your house, place your hardy hard-wooded plants, such as Heaths, Epacris, &c., at the ends; next, the Cinerarias and Geraniums, &c.; and in the middle, such temporary plants as I have indicated to-day; and then give air at the ends, but give none in the middle. Supposing you can command the greatest heat at one end, just act accordingly. One part of the house will thus not only be warmer than the other, but there will be less movement in the atmosphere.

R. FISH.

CONSERVATIVE WALLS.

(Continued from page 264.)

I AM very much pleased with the remarks of my courteous friend, Mr. Fish, at page 262, on these walls, and think he is quite correct in observing, that we need a well-defined name for every object in gardening. He, and our readers, will remember, that I was not satisfied with the present term *Conservative Wall*, but would rather invent a new name, and call them *Preservative Walls*. This name, with due deference, I submit to Mr. Fish, would be, in many respects, better than *Conservatory Walls*, because that term would give an idea of what is called, *par excellence*, the *Conservatory*, a kind of aristocratic greenhouse, in which the plants, instead of being grown in pots, are either planted out in beds, or in pots. These are plunged out of sight, upon which point I may just remark, in passing, that where the plants are of a rampant habit of growth, the plunging them in pots has a tendency to prevent over luxuriance, and induce a more flowering habit. Whether the gardening world will adopt either Mr. Fish's name or mine, is rather doubtful; for when once a name has got firmly established in the many-headed thing, called the public, it is almost an Herculean task to bring another, though a far better-defined name into general use. To conclude this tirade about a name, I would just define the words *Preservative Wall* to mean a wall to grow plants against, with or without glass, heated or not heated. This will distinguish it clearly enough from a *Conservatory*, a *Greenhouse*, or any other kind of garden erection. I now return to my original subject; and the next of my series of queries is—What kind of plants should be planted against a *Preservative Wall*? Perhaps the best way to answer this will be by a negative description of what should not be planted. As it is an erection to cultivate either plants with beautiful foliage, though of small merit in bloom, and others of fine foliage and beautiful flowers, no plants of a fugacious habit should be used, such, for instance, as *Cobea scandens*, *Tropaeolum Jarrattii*, and *T. azurea*, *Pelargoniums*, the varieties of decided stove-plants, and all annuals. Neither should any be planted that are decidedly hardy enough to grow and bloom in the open air in every part of Great Britain. Some plants are sufficiently hardy to bear the climate of Devon and Cornwall, and such may be fairly admitted as candidates for the honour of being sheltered by a *Preservative Wall* in the more northern parts of the country; whilst, again, in the mild climate of the counties referred to, some of the most hardy stove-plants might be admitted under their protecting and preserving influence, should one, or more than one, be put up in those parts of the country.

Since I began these papers on these walls, I have had several letters on the subject; and one correspondent suggests, "instead of being at the expense of a heating apparatus, fuel, and attendance, would it not be desirable to have a moveable canvass covering to roll down in frosty weather; and would not that be a sufficient preservative for the kind of plants proper for a wall of this kind?" To this I can only reply, that I do not now, nor ever have stated, that a heated wall, or a glass-covered wall, was absolutely indispensable; but with these additions of heat and glass, the building would be more ornamental and more enjoyable; and thus it follows, as a matter of course, that to have a *Preservative Wall* in perfection, the addition of heat and glass are desirable. If the wall is glass-cased only, and not heated, such a covering as my correspondent mentions would be very useful, and would be certain to ward off a great amount of cold in frosty, severe weather, as well as preventing the radiation of heat from the interior through the glass. Plants, as Mr. Fish very justly observes, do not suffer so much when they are *still*, or,

in other words, when they are not exposed to cold, cutting, frosty winds. To prove this, if proof were necessary, I have seen Cinerarias with their leaves stiff with frost in a cold pit, where, of course, they were perfectly *still*, recover from it by, as it were, naturally thawing in the dark, but had they been exposed to a wind while frozen, they would have been destroyed to a certainty; and if such a tender soft foliaged plant as the Cineraria will bear a certain degree of frost if in a still atmosphere, there is no wonder that such plants as I shall in my next paper on this subject name, enduring a greater amount of cold in a glass-covered non-heated wall, because they are still, than they would if exposed to the cold frosty winds of the driving blasts of winter; and this quiet fact is important in cultivation, to a considerable extent, in the kitchen garden; such plants as Cauliflowers under a hand-light, as is well known, do not suffer from frost, however severe, because they are still; and in the flower garden, we might preserve many plants if protected by similar means from cutting winds.

T. APPLEBY.

(To be continued.)

THE AURICULA.

Autumn and Winter Treatment.—The autumn treatment may be considered to commence as soon as the bloom is over. The plants should then be placed upon a thick bed of coal-ashes, or on boards, behind a hedge, or low north-wall. In this situation they will be protected from the hot sun, and will quietly grow. The attentions they require are regular supplies of water, not saturating showers from a rosed-pot, but just enough to keep them growing. In very wet weather, it will be desirable, where expense is no object, to protect them from heavy showers. I remember, when I was a boy, going to visit an ardent cultivator of the Auricula. Mr. John Wright was his name, and he lived at a place called Marsh, about two miles from Huddersfield, in Yorkshire. He had a large and valuable collection, of which he was justly proud. To protect them from the heavy autumnal rains, he had the space they occupied covered with a sloping roof of oiled canvass, so contrived as to roll up in fine weather, and so high from the ground that he could stand upright within it, and thus was able to attend to their comfort and well-being in all weathers. I was so struck with the complete shelter, neat arrangement, and extreme health of the plants, that I have, even at this distance of time (more than forty years), a lively recollection of the excellence of the plan, and the beautiful healthy appearance of the plants; though now, alas! both the owner and his plants have been passed away for many, many years; so long, that I question whether any inhabitant of that neighbourhood has any recollection of either that indefatigable cultivator, or his fine collection of Auriculas and Polyanthuses.

Such a shelter is by no means expensive. It might be formed against a wall, about twelve feet high, with upright posts in front, and rafters of larch poles fixed to the wall, and a covering of oiled canvass stretched over them, and allowed to hang down a foot or two in front. It should be at least nine feet wide, and as long as the number of plants may require. In the instance above, the plants were arranged on a sloping stage, such as we often see in old-fashioned lean-to greenhouses. This plan is commendable, because each plant receives its due share of light and attention; and the erection might be used, when the Auriculas do not require it, for various other plants requiring such a shelter.

In this autumnal habitation the Auriculas should remain till the end of September. About the beginning of that month, is, in my opinion (borne out by practice),

the best season for repotting the plants. If they are potted earlier, they make their growth, and often send up flower-stems in the early part of winter. This exhausts the energies of the plant, and the second flower-stems produced in spring are much weakened thereby. Some week or ten days previous to the potting-day bring the compost under shelter to become moderately dry, but do not attempt to mix the different ingredients of the compost till they are all in that state.

As soon as the compost is in a fit state for use, bring a portion of the plants into the potting-shed, or if the weather is fine they may be potted on a bench in the open air. If the pots are fresh from the pottery it will be advisable to dip them in water, allowing them to become dry again before using, but if they are old, they should be clean washed. Then have ready a sufficient quantity of clean, broken potsherds for drainage; also a sufficient number of fresh tallies, if the old ones are made of wood. All these being in order, commence potting by turning out of the pot the first plant. Examine the roots, and cut away all that are dead or decaying; shake off the greater part of the old soil, and remove all rooted offsets, laying them on one side till the parent plant is potted. If the root-stock or stem below the soil is too long, so as to elevate the plant too much above the soil (some varieties are apt to elongate more than others), cut the bottom part off with a sharp knife, and apply a little powdered chalk to heal up the wound. This will allow the heart of the plant to be brought down nearer to the soil, and the part of the stem thus brought within the soil will throw out fresh roots and greatly encourage growth. Place over the drainage some of the turfy fibres of the loam, place a thin layer of soil upon it, and then hold the plant in the left hand, place it in the pot, and work in the compost amongst the roots, gradually filling the pot to within half-an-inch of the top, then give the pot a smart stroke upon the bench to shake down the soil firm, and add a little more to fill up the pot to within a quarter-of-an-inch of the top. Press it gently down and closely to the stem all round, and the operation is complete. Before putting the plant out of the way, see to the label or tally, and if a new one is required, place one to it, and then set the plant aside; pot the offsets first, before touching the next; place a tally to them, and then take another plant in hand, and so proceed till the whole are finished. The season of the year has now arrived when the Auricula should have a more southern situation. The sun's beams will now be so moderated, that the plants are able to bear a fuller exposure to them. I now recommend the frame or stage to be placed in front of a west wall facing the east. In that aspect they may, if the weather is clear and warm, require a slight shading from the sun's beams till they have made fresh shoots. The shading may then be discontinued. Here they may remain till the end of October, when they must be placed in their winter quarters; the treatment while there will be our next consideration.

T. APPLEBY.

(To be continued.)

DESTRUCTION OF WEEDS.

In the eyes of a botanist, no class of plants are recognized as "weeds," and, with some show of reason, he complains of the tyranny of cultivators who can see no beauty and no interest in anything but that limited number of species they are pleased to call the legitimate occupants of their soil; now, though we have no wish to fan the flame of discord between the botanical and horticultural world, we would rather see the two united, which may easily be done without any great sacrifice on either side, especially in the case we

now have before us, because, though many of our most common British plants present features of great interest to the inquiring botanist, those which infest our walks, squares, and borders, are so abundant as to require no particular notice at our hands in the shape of "protective enactments;" for the dandelion, which blooms by the road-side wastes, is identical to the one which now and then we see insinuating itself into the less frequented walks of the garden of medium keeping, and though it is seldom allowed to bloom in the latter place, yet its efforts to accomplish that object there, as well as on the close-shorn lawn, shew, in a beautiful way, what struggles nature now and then is capable of undertaking in order to accomplish that important duty of multiplying her species. But, in the present instance, our duty is to prevent that increase rather than encourage it; and, in a mild open winter, the class of plants called weeds (which, according to the late Mr. Loudon's definition of the term, includes every plant not cultivated) are generally allowed to grow away with a sort of impunity which it is difficult to check, the mass of other work, and the adverse elements concurring to their well-being rather than their extirpation. This state of things must not, however, be allowed to go on too long, otherwise something worse than mere present appearance will follow. Squares of vacant ground that the continued wet has prevented a spade being put in may be dug, and all the annual weeds buried; perennial ones, being deeper rooted, ought to be carefully dug out and carried right away at once. Amongst close-growing crops the system of hand-weeding must be put in requisition; while many that will allow the spade in between them will be benefited by slight digging, when the ground will allow it, and thereby bury all small annual weeds, which, instead of being impoverishers of the ground, will become renovators of it, and that freshness which newly-turned-up soil always imparts to growing crops will be gratefully acknowledged by them in the shape of increased growth. This "digging in" is, therefore, attended with the best possible results, so that, whenever crops of cabbages, or similar things, present a quantity of small seedling weeds, which it is advisable to eradicate, this digging in will accomplish the job with the additional advantage of conferring a benefit on the existing crop. How far this may be carried on in other ways will depend on certain local circumstances. On some soils weeds will struggle successfully in again getting their heads above ground, while in others the attempt seems abortive. However, in a general way, we are no advocates for carrying any quantity of annual weeds or other vegetable refuse off the ground, unless it be of a kind of extremely slow decomposition, as the stalks of the cabbage tribe, and haulm of asparagus; the latter, forming a tolerable good covering for things requiring protection, is often used that way. And when the stalks of the Cabbage-worts are stript of their leaves, the remaining portion is too small to run the risk of contaminating the ground, if it is dug in with wire-worm, and other pests. That this would be the case is evident from the numbers that congregate around a half-decayed stem of this plant where it is left in the ground; while the succulent herbage of ordinary weeds present nothing but a quiet-decaying substance to the action of the soil, to which it is speedily assimilated when vitality is gone.

From the above, it will be seen that digging in weeds and other herbage is strongly advised, as returning to the earth those elementary parts it is so much in need of; but then another question arises—what is to become of the weeds which a wet, mild winter sends forth on our walks, court-yards, carriage-roads, and other places where neatness is (or ought to be) "cultivated" instead of "plants?" Here a system of anti-cultivation must be pursued; but how is this opposing course to be

accomplished has been the theme of much controversy. In a usual way, the remedy is labour, and hand-weeding or hoeing is had recourse to—the latter, of course, the most expeditious when practicable; but this not being so in many cases, and hand-weeding tedious and expensive, various expedients have been adopted to destroy the weeds by other means than removing them. Poisonous ingredients have been applied in the shape of gas water, and infusions of various mineral poisons, with more or less success; but as all these are either dangerous in their use, or expensive appliances, it would appear that much yet has to be done in the way of annihilating weeds from such places. Salt has been strongly recommended, and by some has no doubt been found beneficial, by others less so; and our experience has been somewhat conflicting that way, that we cannot, without some qualification, recommend its use.

If it is employed at all it must be systematically followed up, and then its benefits will doubtless show themselves. A slight sprinkling of salt, followed by wet weather, cannot be expected to effect any permanent good; but repeated and judicious applications may, and no doubt do, so saturate the ground with its saline particles as to be no longer in a condition fit to support vegetable life. That the cases of successful management, when this course is adopted, arise from this cause, is evident enough, while a solitary dose may have given increased fertility to the places where it has not been repeated. Hot water, too, has been strongly recommended, and Mr. Fleming's machine for blending the two together would seem to have supplied the desideratum we have so long been aiming at. Unfortunately, its first expense, coupled with the difficulty there is sometimes of supplying it with water, &c., in sufficient quantities to make its working economical, prevents its general use, so that we hope yet to see some cheaper and readier way of dealing out destruction to the myriads of weeds and mosses which disfigure all walks not much used; the latter class of vegetation has been more conspicuous during the past autumn than any hitherto for some years, the mild, moist weather being so congenial to its growth.

Where, on sound, well-prepared walks it is not advisable to disturb any portion of their surface, some other destroyer must be put in requisition. A very good one may be adopted at times, when the weather admits it, which is not, however, always; but where moss is growing on the surface of a path consisting of gravel or stones that have become smoothed tolerably fine by rolling or use, the moss will be found occupying all the interstices between such stones. Now, to remove it from thence by ordinary hand-labour would be both troublesome and expensive, it is, therefore, better if we can avail ourselves of the elements to effect our purpose thence, which in this case can be done in many instances. Charged as this vegetation is with water, together with the ground that supports it, a sharp frost exercises a destructive power upon it; but, more than that, the expansive powers of frost raises from the ground the whole mass of vegetable life, with its roots, &c., so as to appear in bold relief to the stones not subject to such a change. While in this condition the exercise of a good scrubby broom has a *sweeping effect*; but it must be borne in mind that it must be done at the precise moment the frost gives way, because a heavy rain sinks it again to its former position. It is only those who have witnessed the phenomenon we speak of that are aware of the singular appearance it has, and only those who avail themselves of the proper time to remove it that can tell of the benefits to be derived from it, as its loosened condition enables it to be removed with more precision than many are aware of, while the stones are not disturbed in the least. Now, though we do not object to the use of salt, or salt and water, either hot or cold, nor to the various

liquids to which poisonous matter has been added, yet, as a simple, safe, and efficacious remedy for the evil complained of above, we advise the use of a little hard labour at the fitting time; and those having walks of the kind mentioned would do well to sweep the snow from them, if needful, and expose them to the full action of frost, which we have no doubt will prove a better friend in the way of destroying moss than the hazardous plan of trusting your edgings, and the roots of trees which may have run underneath the walk, to the tender mercies of repeated applications of deleterious matter. That the latter may, with perfect propriety, be adapted to those cases where there is no danger of such a course, we certainly admit—nay, even advise—but we confess our inability to point out the most suitable ingredient applicable in all cases. Parties residing in the neighbourhood of gas-works might easily obtain that poisonous liquid called gas-water; various chemical factories also present waste matter available to places sufficiently near; but these are isolated cases, and cannot be fairly said to meet the object in view. What we want, is a cheap, safe, and effectual remedy for the destruction, or rather prevention, of weeds growing on walks and other places where their presence cannot be tolerated. That the exertion of some one who may devote his attention to a successful issue in this matter will be gratefully received by the gardening world, we have no hesitation in affirming; while, at the same time, we can hardly expect the first efforts of skill to be entirely all we want; but, from the importance of the case, we should like to have the opinion of some one well versed in chemistry pointing out the way; while, of the manufacturing patrons of horticulture, we again ask, what has been several times repeated in *THE COTTAGE GARDENER*, What can they do in providing us with a cheap and better covering for our frames than the things we now employ? This, like the “weed annihilator,” is assuredly more in the province of others than that of the gardener; and we invite such to our aid, assuring them that no class are more grateful for favour shown, and in none is the selfish, restrictive policy of keeping knowledge at home so seldom found, as in the horticulturist.

J. ROBSON.

PANSIES GROWN IN SCOTLAND.

As I only receive *THE COTTAGE GARDENER* once a month, I have just noticed an article in that of the 9th of December, 1852, containing a list of Pansies, furnished “by a gentleman so far north as Berwick-upon-Tweed,” and although, in the main, generally good, still I do not think that it shows the southern growers what amateurs residing “a lectle farther north,” near Auld Reekie, can do; and I annex you a list of what I consider a better, and not more expensive, selection, suitable for a small garden. I have myself upwards of 120 varieties; and as I have flowered every one that I have mentioned in the annexed list, with the exception of *Boadicea* (Fellows), I can confidently recommend them. You will observe I have retained what I consider good in our Berwick friend’s list.

WHITE GROUNDS, WITH MARGINS OF BLUE, PURPLE, LILAC, AND THEIR INTERMEDIATE SHADES.

Boadicea (Fellows); white and purple (not known to writer).

Duchess of Rutland (Thomson); white and lilac; good, but uncertain.

France Cycole (Grieve); white and maroon; old, but good.

Helen (Hunt); white and light purple; good when caught.

Lord Jeffrey (Lightbody); white and dark blue; good.

Miriam (Dickson and Co.); white and dark purple; eye sometimes run; when caught, fine.

Mirror (Dickson and Co.); white, and broad blue belt; fine.

Miss Talbot (Dickson and Co.); white and purple; very fine.

Miss Maxwell (Downie and Laird); white and dark blue; fine and constant.

Mrs. Blackwood (Downie and Laird); white and pale bluish-purple; good; new.

Mrs. Beck (Turner); white and purple; very fine.

Queen of England (Fellows); white and bright blue; good.

Royal Standard (Dickson and Co.); white and dark purple; best of its class.

Royal Visit (Dickson and Co.); white and deep maroon; very fine.

YELLOW GROUNDS, WITH MARGINS OF MAROON, BLUE, PURPLE, AND THEIR SHADES.

Constance (Thomson); yellow and purple; small, but good.

Diadem (Fellows); gold and maroon; very fine.

Duke of Norfolk (Bells); yellow and deep maroon; runs in heat of summer, but good when caught.

Elegant (Thomson); gold and bronze-red; fine.

Gliff (Dickson and Co.); yellow and maroon; very large.

Jubilee (Dickson and Co.); pale yellow and reddish-purple; neat; medium size.

Juventa (Hooper); yellow and maroon; fine.

Lady Emilie (Downie and Laird); yellow and claret; constant.

Mr. Beck (Turner); yellow and maroon; good, but very like *Orestes* (Gossett’s).

Post Captain (Maishment); yellow and bronzy-purple; constant.

Robert Burns (Campbell); yellow and fine purple; very large; fine.

Supreme (Youell’s); yellow and maroon; one of the finest old varieties, not beat yet.

SELFS.

Adela (Turner); yellow; fine.

Ajax (Downie and Laird); dark blue; very fine form, and constant.

Blanche (Turner); finest white out; splendid blotch.

D’Israeli (Hunt); glossy purple; fine when caught.

Flower-of-the-Day (Downie and Laird); fine plum; golden eye.

King (Jennings); dark purple; fine.

Magnificent (Neilson); shaded puce, laced with white; fine.

Nox (Hooper); dark blue; very fine.

Sambo (Hale); dark plum; good.

St. Andrew (Downie and Laird); nearly black; very fine.

Sovereign (Dickson and Co.); golden-yellow; one of the finest in cultivation.

Uranus (Dickson and Co.); good yellow, but uncertain.

PANSELANA, Edinburgh.

GREAT METROPOLITAN POULTRY SHOW.

It would be a difficult task to decide to whom, or to what county, is fairly due the credit of having originated the exhibitions now so common, which are encouraging the cultivation and improvement of the various breeds of poultry, and opening, to an extent likely still to be much enlarged, a source of profit to the farmer and the cottager, and of interest and amusement to Peer and peasant alike.

The pages of *THE COTTAGE GARDENER* have contained accounts of shows of poultry in various parts of England. Halifax, Hull, Preston, Liverpool, and other towns, have spoken to the interest excited on this subject in the north; Winchester, Salisbury, &c., have borne witness to a corresponding spirit in the south; Cheltenham and Birmingham have represented the midland counties; and while Yarmouth, Norwich, and Hitchin, have done their part in the east; Bristol, Torquay, Truro, and Penzance, have shown that the west, to the very Land’s End, are not behind in the competition. But to the surprise of many, and the regret of more, no show in London worthy of the Metropolis had yet taken place. This was the more to be lamented, because in spite of confined yards, smoky atmosphere, and want of grass, the taste for poultry in London has been long and successfully cultivated, and more especially by many tradesmen and mechanics, who, though debarred by circumstances from attending and exhibiting at some of the country shows, have possessed their favourite White-faced Spanish, or

Shanghae pets, on whom they have bestowed as much care as the feathered favourites in more spacious "walks," have ever received from their owners.

The difficulty of establishing a Metropolitan Show arose partly from the fact, that London (unlike Birmingham) possessed no Bingley Hall suitable for the reception of a large number of poultry. Few persons, moreover, were eager to embark in so large an undertaking, with the certainty of great trouble and responsibility, and the risk of heavy pecuniary loss.

Things would probably have thus remained, but for the zeal and energy of one very eager and experienced, as well as successful, poultry-amateur, Mr. Henry Gilbert. Encouraged by the promise of assistance from his friends in the country, that gentlemen undertook the task, and, aided by a clear-headed and hard-working committee, he has most ably surmounted all difficulties, and has fully attained the success he so well deserved. He has succeeded in collecting a show of poultry, second only to that which a month before took place at Birmingham; and he has given great pleasure to the many, who, during the four days of the exhibition, crowded the Bazaar, and showed the lively interest they took in the various breeds which were there displayed.

To the many readers of THE COTTAGE GARDENER who were unable themselves to be present, we propose to give a short, and, we hope, an impartial account of what we saw there, and to offer the opinions, which, to the best of our judgment, we formed.

The original place fixed upon for the show was the Oval at Kennington. At the eleventh hour, however, the committee found this would not be permitted. No alternative, therefore, presented itself but that of deferring the day from the 1st to the 11th of January, while arrangements were being made to receive the poultry at the Baker-street Bazaar, a "locale," which, indeed, in most respects, we consider a preferable one to the Oval. In the galleries of this building very commodious and roomy pens were erected; and the space left for the visitors, and the arrangements regarding lighting and ventilation, were nearly all that could be desired.

For the information of our readers we annex a comparison of the entries of each variety, made respectively at Birmingham and the Metropolitan. It will be seen that (especially as a first attempt) the latter has no cause for shame in the comparison.

PENS ENTERED.

Classes	Birm.	Metr.
Spanish	64	36
Dorking	142	70
Shanghaes	275	249
Malays	10	10
Game	164	48
Golden-pencilled Hamburgs	13	11
Golden-spangled Hamburgs	28	11
Silver pencilled Hamburgs	58	21
Silver-spangled Hamburgs	66	14
Poland	68	37
Cuckoo	6	..
Rumpless	4	..
Andalusian	2	..
Ancona	1	..
Frizzled	4	..
Norfolk or Surrey	2	..
Bantams, Gold-laced	35	24
" Silver-laced	6	11
" White	12	13
" Black	13	16
" other varieties	5	45
Pigeons	85	about 250
Geese	18	11
Ducks	73	33
Turkeys	23	10
Guinea-fowl	6	..
Extra Class	27

In these classes, therefore (besides rabbits), nearly 700 pens of poultry were arranged, and taken as a whole, they may be considered a very good collection, amongst which were many superior specimens.

The list of prizes was framed on the scale adopted at Birmingham, and was a liberal one. The general rules

were also the same, with the exception of two, which were (as we think) with advantage omitted.

We know that the Birmingham clause, requiring a "two months ownership," was evaded there, and as we see no real use in it, we rejoice in its exclusion from the Metropolitan rules.

We also approve of the regulation which allows any subscriber to send to the show any number of pens, on a certain payment for each pen, instead of (as at Birmingham) limiting the number to six pens, which, as we know, was also evaded there, and is, therefore, an unwise rule, if only because it is inoperative.

We must, however, express our opinion, that the corrections might still have been judiciously extended, and there are two rules especially, which, before any future meeting, we would gladly see altered.

1st. If, as at present, chickens are allowed to compete with old birds, we assert that the comparison must be very unfair to the latter. The plumage of the chickens (especially in the Dorking and some other classes) will be brighter, and show better than that of the adult birds. We think that chickens ought to show against chickens, and old birds against their fellows.

2nd. To any real amateur, the length of time during which the poultry are retained in the show, and the suffering (and risk of life even) which in consequence they undergo, must be a subject of regret; and we will venture to express a hope, that at the next Metropolitan Show the committee will take another step in the right direction. To say "that the time is the same as it was at Birmingham," does not prove that it is well to retain the poultry so long. If the poultry were received on the Monday, and judged on Tuesday, and if, instead of four days, the show were limited to three days, which would be enough to gratify public curiosity, the fowls might then be released on Friday night, to the mutual convenience and satisfaction (we are sure we may say) of themselves and their owners. We will now nothing extenuate, nor set down aught in malice, but proceed with our critique on the different classes, which we will take in the order in which they stand in the prize list.

The Spanish class, which contained altogether 36 entries, was well represented. The first prize, for a cock and three hens, falling to a very perfect pen (9) belonging to Captain Hornby. Mr. Fox taking the second. The prizes in the second class, for Spanish chicken, going to Mr. Fox, Mr. Whittington, and Captain Hornby, who also won the 1st prize in class 3.

Of Dorkings of various sorts, there were altogether 70 entries, and this was considered a very good class. For the various winners we must refer our readers to the prize list, only remarking that we are very glad that the Committee liberally awarded to Captain Hornby an extra first prize, as the mistake which had deprived him of it arose from the Society's own men when taking the birds from their baskets.

The Cochins classes, as usual, attracted great attention, and well repaid the careful inspection they received, for (with the exception of classes 13 and 14, which we thought very moderate) the pens presented, generally, a very good collection of birds.

Amongst the White Cochins was a beautiful pen belonging to Mr. Fairlie, which received the first prize, as did also a very good lot, the property of Dr. Allen, in the chicken class.

Of Malays, there was but a small show, and we cannot say we much admire this class.

The Game fowls mustered in force, consisting altogether of 48 pens, which attracted much attention, and as a class deserved great commendation, which may also be said of the various breeds of Hamburgs, both Spangled and Pencilled. Amongst the Silver-pencilled, especially, were some good pens, particularly one belonging to Mr. McCann.

A good show of Poland, which did not, however, attract very much attention. We think this class (like the Malays) are becoming much less popular than formerly.

The Bantams were a numerous class, and on the whole well represented. As usual, they had a constant succession of admirers, especially among the ladies.

Class 47, for any other distinct breed, had 45 entries of all sorts, amongst which we observed some black Cochins, belonging to Mr. Fairlie, which were much admired; and

some *Bramah Poutras*, which we think no acquisition to the poultry-yard.

Besides this, there were 27 entries of extra stock, only entered for sale, containing (with other things) some good Cochin-Chinas.

The Class for *Geese*, though only consisting of 11 entries, showed some very good pens; as did also the division for the *Turkies*, especially those belonging to Mr. Fairlie, who took the first and second prizes, which he well merited. The weight of one of the Turkey cocks we heard exceeded 32 lbs.

It has often been a subject of surprise to us, that to these two classes better prizes are not awarded, as there is great room for improvement in the former by judicious crosses; and the excellence of the latter class attained here can only be done by care and trouble.

The *Ducks* were a good class. A fine pen of Aylesburys, belonging to Mr. Jennens, taking the first prize; whilst that for Rouens fell to an equally deserving one, the property of Mr. Worrall.

The Pigeons (of which there were about 250 pens), as a class, rather disappointed expectation. There were, however, some favourable exceptions, amongst which may be named some Carriers belonging to Mr. Hayne.

The Rabbits (of which about 50 were shown) were an excellent collection, but did not seem to attract attention, probably from a want of the knowledge of what constitutes their points of excellence.

The arrangements generally were good, though still capable of the improvement which, next year, we doubt not will take place; but disappointment was expressed at the delay in issuing prize lists, which we did not succeed in getting until the third day. Great care seemed to be bestowed in feeding and cleaning the birds, so as to soften, as much as possible, their long confinement; and to destroy every egg laid in the pens. We cannot approve of the resolution to offer all the poultry to competition by auction on the third day—a system (we think) which cannot prove profitable to sellers, and was (we know) not approved of by many would-be-buyers.

The judges were E. Hewitt Esq., of Birmingham; W. Symonds, Esq., of Weymouth; and Mr. J. Baily, of London; and we believe the care and attention which they bestowed in the discharge of their arduous duties secured general approbation; and though, with so many entries, there must be some few disappointed exhibitors, we understand the verdicts were generally concurred in.

We hope, however, that 1853 will see introduced a change in the system of judgment. We should like more judges appointed, say four judges for the adult birds, and the same number for the chickens, with a referee for each; for we contend that the examination, as at Birmingham, of 1300 pens, working for thirteen hours, is too much for the physical powers of one set of men. We were glad to hear that many of the principal exhibitors had come to the resolution of never sending their birds to any show where they would be kept more than three days. We hope this will be adhered to.

In conclusion, our congratulations are justly due to the Committee and Secretary, who have gallantly started and successfully carried out, a Poultry Show, bidding fair to be a dangerous rival to the Birmingham Society, which, though now holding the rank of the first Exhibition of Poultry in England, will require all the energy of its committee, and many alterations made in the management, or its fame may be eclipsed, and its position usurped by the Great Metropolitan Exhibition.

K.

The following is a list of prizes awarded by the judges:—

SPANISH.

Class 1.—Pen 9, first prize, Captain Hornby, Knowsley Cottage, near Prescott, Lancashire; second prize, 1, Mr. Fox, Skinner-street, Snow-hill; third prize, 3, Mr. Thomas Jones, Vale-place, Hammersmith.

Class 2.—First prize, 1, Mr. Thomas Fox, Skinner-street, Snow-hill; second prize, 3, Mr. T. Jones, Vale-place, Hammersmith; third prize, 11, Captain Hornby.

Class 3.—First prize, Captain Hornby; second prize, 7, John Taylor, Esq., Shepherd's Bush.

DORKING (Single-combed).

Class 4.—First prize, 2, Mr. J. Lewry, Handcross, Crawley; second prize, 4, Mr. J. Boys, Biddenham; third prizes, 11 and 12, Captain Hornby.

Class 5.—First prize, 2, Mr. J. Lewry; extra first prize, 11, Captain Hornby; second prize, 10, Mr. John Fairlie, Cheveley-park, Newmarket; third prize, 8, Mrs. F. Noyes, Salisbury.

DORKING (Double or Rose-combed).

Class 6.—First prize, 3, Sir J. Cathcart, Cooper's-hill, Chertsey; second prize, 2, Mr. J. Thorn, Mawley-house, South Lambeth.

Class 7.—First prize, 1, Mr. Thomas Nice, Great Bradley-Hall, Newmarket; second prize, 4, Mr. John Fairlie.

DORKING (Double or Single-combed).

Class 8.—First prize, 13, Captain Hornby; second prize, 6, Rev. John Boys.

DORKING (White).

Class 9.—First prize, 3, Mr. J. Jennens, Mozeley; second prize, 5, Mr. James Oldham, Long Exton, Derby; third prize, 7, Mr. Nathaniel Antill, Portsea.

Class 10.—First prize, 2, Mr. Joseph Jennens, Mozeley; second prize, 1, Mr. H. Forster, Markgate-street, Dunstable.

COCHIN-CHINA (Cinnamon and Buff).

Class 11.—First prize, 9, Mr. John Fairlie, Newmarket; second prize, Mr. T. Potts, Kingwood-lodge, Croydon; third prize, ditto.

Class 12.—First prize, 50, Mr. T. Potts, Kingwood-lodge, Croydon; second prize, 49, Mr. T. Potts, Kingwood-lodge, Croydon; third prize, 1, Captain Squire, Barton-place, Mildenhall.

COCHIN-CHINA (Brown or Partridge Feathered).

Class 13.—First prize, 6, Mr. John Chater, Haverhill; second prize, 7, Mr. Thomas Bridges, Bridge-cottage, Croydon.

Class 14.—First prize, 10, Mr. Thomas, York.

COCHIN-CHINA (Cinnamon and Buff, or Brown).

Class 15.—First prize, 81, Mr. John Bidewell, Guildford; second prize, 7, Mrs. George, Chalden, Coulsdon, Surrey; third prize, 1, Captain Squire.

COCHIN-CHINA (White).

Class 16.—First prize, 4, Mr. J. Fairlie; second prize, 2, Mr. E. L. Preston, Great Yarmouth.

Class 17.—First prize, 5, Rev. Dr. Allen, Englefield-green; second prize, 1, Mr. G. C. Adkins, Edgbaston.

MALAY.

Class 18.—First prize, 4, Rev. Dr. Allen, Englefield Green; second prize, 3, Mr. W. Wodehouse, 68, Bridport-place, Hoxton; third prize, 1, Mr. W. W. Hayne, Sutton, Surrey.

Class 19.—First prize, 3, Mr. S. Soames, Stepney, Middlesex; second prize, 6, Mr. G. Oldham, Nether Whiteacre.

GAME FOWL (White and Piles).

Class 20.—First prize, 6, Mr. H. Thurnall; second prize, 2, Mr. W. G. Vivian, Singleton, Glamorganshire.

Class 21.—First prize, 3, Mr. W. Groom, Holt, Norfolk; second prize, 1, Mr. R. Wilton, Moon-place, Stamford-le-Hope.

GAME FOWL (Black-breasted and other Reds).

Class 22.—First prize, 7, Captain Hornby; second prize, 1, Mr. F. H. Powell, Hillingdon, Middlesex; third prize, 4, Mr. A. Connell, Cingleford, Norfolk.

Class 23.—First prize, 3, Mr. M. Wilson; second prize, 11, Mr. Thurnall, Royston.

GAME FOWL (Blacks and Brassy-winged, except Grays).

Class 25.—First prize, 2, Mr. W. Dester, Seckington, Warwickshire; second prize, 1, Mr. R. W. Wilson.

GAME FOWL (Duckwings and other Grays and Blues.)

Class 26.—First prize, 4, Mr. H. Thurnall, Royston, Cambridgeshire; second prize, 2, Mr. E. A. Lingard, Snow-hill, Birmingham; third prize, 3, Mr. G. C. Adkins, Edgbaston.

Class 27.—First prize, 1, Mr. R. W. Wilson; second prize, 2, Mr. R. W. Wilson; third prize, 3, Mr. C. Stinton, Hamworth.

GOLDEN-PENCILLED HAMBURGH.

Class 28.—First prize, 2, Mr. J. B. Chune, Colebrooke-dale; second prize, 5, Mr. J. E. Mapplebeck, Highgate, Birmingham; third prize, 1, Mr. T. Church, Acle, Norfolk.

Class 29.—First prize, 2, Mr. H. Worrall, Knotty Ash-house, Liverpool; second prize, 1, Mr. T. Barber, Acle, Norfolk.

GOLDEN-SPANGLED HAMBURGH.

Class 30.—First prize, 3, Mr. G. Adkins; second prize, 1, Mr. Lightfoot, Markgate-street, Dunstable; third prize, 4, Mr. G. Adkins.

Class 31.—First prize, 4, Mr. J. Mould, Makinney-house, Belper; second prize, 5, ditto.

SILVER-PENCILLED HAMBURGH.

Class 32.—First prize, 8, Mr. E. How, Bromley, Middlesex; second prize, 1, Mr. E. Archer; third prize, 4, Mr. F. Wigan, Edgbaston.

Class 33.—First prize, 3, Mr. G. McCann, Malvern; second prize, 10, Mr. J. Mapplebeck.

SILVER-SPANGLED HAMBURGH.

Class 34.—First prize, 2, Mr. J. Whilock, Birmingham; second prize, 4, Mr. W. G. Chambers, Portsmouth; third prize, 1, Mr. J. Whilock.

Class 35.—First prize, 4, Mr. E. Simons, Dale-end, Birmingham; second prize, 2, Mr. J. Whilock.

POLAND FOWL (Black, with White Crests.)

Class 36.—First prize, 1, Mr. G. C. Adkins; second prize, 2, ditto; third prize, 4, Mr. T. B. Edwards, Lyndhurst.

Class 37.—First prize, 3, Mr. T. P. Edwards, Lyndhurst; second prize, 2, Mr. W. G. Chambers, Portsmouth.

POLAND FOWL (Golden, with Ruffs or Beards).

Class 38.—First prize, 3, Mr. J. E. Mapplebeck; second prize, 1, Mr. W. G. Vivian; third prize, 2, Mr. C. Clarke, Street, near Glastonbury.

Class 39.—First prize, 1, Master G. Horner, Charlotte-street, Hull.

POLAND FOWL. (Golden, without Ruffs or Beards).

Class 40.—First prize, 1, Mr. J. E. Mapplebeck, Birmingham; second prize, 2, Miss E. S. Perkins, Sutton Coldfield.

Class 41.—First prize, 3, Mr. W. Cutler, Bathampton; second prize, 4, the Hon. Mrs. Finch, Berkhamstead.

POLAND FOWL. (Silver, with Ruffs or Beards).

Class 42.—First prize, 3, Messrs. Baker, Chelsea; second prize, 2, Mr. C. Clarke; third prize, 1, Mr. W. G. Vivian.

Class 43.—First prize, 1, Mr. W. G. Vivian; second prize, 3, Master G. Horner.

POLAND FOWL. (Silver, without Ruffs or Beards).

Class 44.—Second prize, 2, Mr. C. J. Mould.

BANTAMS. (Gold-laced).

Class 46.—First prize, 4, Mr. G. C. Adkins; second prize, 21, Mr. H. T. Leigh, Turnham-green.

BANTAMS. (Silver-laced).

First prize, 26, Mr. H. J. Jones, Bedford; second prize, 29, Mr. J. Fairlie.

BANTAMS. (White).

First prize, 40, the Rev. G. F. Hodgson; second prize, 46, Mr. W. Beller.

BANTAMS. (Black).

First prize, 56, Mr. J. Fairlie; second prize, 49, Mr. F. H. Fox.

BANTAMS. (Black-breasted Red).

First prize, 62, Mr. W. S. Forrest, Greenhithe.

BANTAMS. (Ginger or Buff).

Second prize, 63, Mr. Dutton, Bury St. Edmunds.

PIGEONS.

- 3. Black cock Carrier. Mr. W. W. Hayne, Sutton.
- 13. Dun cock Carrier. Mr. G. C. Adkins, Edgbaston.
- 16. Blue cock Carrier. Mr. W. W. Hayne, Sutton.
- 17. Blue cock Carrier. Mr. W. W. Hayne, Sutton.
- 52. One pair silver short-faced Baldheads. Mr. F. Thirkell, Sydenham.
- 59. One pair black Jacobines. Mr. F. Thirkell, Sydenham.
- 62. One pair red Jacobines. Mr. F. Thirkell, Sydenham.
- 67. One pair yellow Jacobines. Mr. F. Thirkell, Sydenham.
- 73. One pair white Jacobines. Mr. F. Thirkell, Sydenham.
- 76. One pair blue Owls. Mr. F. Thirkell, Sydenham.
- 78. One pair silver Owls. Mr. G. C. Adkins, Edgbaston.
- 81. One pair yellow Owls. Mr. C. H. Brown, Fulham.
- 84. One pair yellow splashed Owls. Mr. F. Watson, Woodbridge, Suffolk.
- 88. One pair black-headed Nuns. Mr. G. C. Adkins, Edgbaston.
- 93. One pair blue Turbits. Mr. A. Grote, the Elms, Upper Tooting.
- 96. One pair black Fantails. Mr. G. C. Adkins, Edgbaston.
- 97. One pair blue Fantails. Mr. H. Child, Sherborne-road.
- 100. One pair white Fantails. Mr. E. Strange, Astley Burgh Hall.
- 111. One pair black Magpies. Mr. G. Vivian, Singleton.
- 115. One pair mottled Trumpeters. Mr. G. B. Chune.
- 116. One pair Spanish Runts. Mr. G. C. Adkins, Edgbaston.
- 126. One pair Archangels. Mr. Baily, jun., 126, Mount-street.
- 135. One pair Dresdens. Mr. G. Vivian, Singleton.
- 136. One pair Australian. Mr. G. C. Adkins, Edgbaston.
- 137. One pair Bronzewing. Mr. G. C. Adkins, Edgbaston.
- 138. One pair Frill Backs. Messrs. Baker, Chelsea.
- 139. One pair Hiredells. Messrs. Baker, Chelsea.
- 140. One pair blue. Mr. G. W. Vivian, Singleton.
- 150. One pair short-faced red Tumblers. Mr. Evans.
- 165. One pair red Baldheads. Mr. Evans.
- 171. One pair Blue Beard, short-faced. Mr. Evans.
- 172. One pair red mottled Tumblers. Mr. Evans.
- 177. One pair black Baldheads. Mr. Evans.
- 187. One pair black mottled Tumblers. Mr. Evans.
- 195. Black Mottles. Mr. J. M. Eaton, 7, Islington Green.
- 212. Large blue Cropper cock. Mr. Evans.
- 213. Large red pied Cropper cock. Mr. Evans.
- 215. Pair black pied Pouters. Mr. Evans.
- 225. Pair white Pouters. Mr. Evans.
- 228. Pair yellow shoulder Turbits.
- 230. Pair white Owls.
- 235. Pair of yellow mottled Dragons.
- 197. Almonds. Third Class, Mr. Eaton, 7, Islington Green.

RABBITS.

- 1. First prize, length of ear. Mr. Haile.
- 44. Second prize, length of ear. Mr. James Handey.
- 37. First prize, black and white. Mr. J. Douthwaite.
- 16. Second prize, black and white. Mr. R. Venes.
- 34. First prize, yellow and white. Mr. W. Crick.
- 15. Second prize, yellow and white. Mr. W. Lock.
- 31. First prize, tortoiseshell. Mr. W. Crick.
- 20. Second prize, tortoiseshell. Mr. J. Macmeikan.
- 23. First prize, blue and white. Mr. J. Macmeikan.
- 38. Second prize, blue and white. Mr. J. Douthwaite.
- 32. First prize, self colour. Mr. W. Crick.
- 40. Second prize, self colour. Mr. J. Littleton.
- 10. First prize, weight. Mr. R. Stinton.
- 19. Second prize, weight. Mr. R. Venes.

ON THE CULTURE OF TROPEOLUM TRICOLORUM.

In an article on this subject, which lately appeared in one of the gardening periodicals, it was stated that bulbs of *Tropeolum tricolorum*, *T. Jarrettii*, &c., occasionally show an

inaptness to break; and in the same article, the only mode of propagation pointed out (beyond that of raising plants from seed) was the striking of cuttings. Now, as I have grown this flower many years, and never yet had a bulb fail to break, and, moreover, have found the bulbs increased as readily as potatoes, it may be useful to my brother amateurs (and to those only I am bold enough to address myself), if I acquaint them with my method.

To begin, then, with the tail of the pig. After the plants have done blooming, I lay the pot, haulm and all on, on its side, in a place open to the south, but well sheltered from the rain. When the haulm is thoroughly dry I remove it, and then leave the pot, with the bulb and earth in it, uncared for till its time for growth again arrives. When the bulbs have started, I remove the old dry soil, and repot in 48's or 60's, in a soil half leaf mould, and half sand, and leave them to continue their growth in the open air till the shoots have grown to the length of a yard or more; then I repot into upright 16's (the largest size I can afford space for), placing the contents of the small at the bottom of the larger pot (having first placed therein a liberal drainage), and as I fill the large pot with earth, I insert round and round within it the yard or so of shoots, so that when the repotting is complete, just the noses only of the growing-stems are visible above the surface of the soil, and I then place the pots in their winter quarters.

In this way I find the plants grow stronger, and flower more freely than when the bulb (as I believe is usually the case) is placed in its blooming-pot just below the surface of the soil. When the time for removal comes, I seldom fail to find eight or ten good-sized bulbs not much smaller than the parent bulb, besides a number of smaller ones in the pot.

The soil I use for the blooming-pots is three-parts of well-decayed turves from a light loamy pasture; two-parts half-rotted leaf mould; and one-part thoroughly decomposed cow-muck. I have occasionally added half-a-part of white sand, but have found that the plants do as well without it. I give no water till plenty of leaves are expanded, and then but sparingly, till the blooms begin to open, when the usual summer watering of greenhouse plants is required.—J. S.

ANTWERP CARRIER PIGEON.

Few persons, I am inclined to think, are really aware of the origin of this pigeon, though most pigeon-fanciers know something of it, in one or other of the many crosses between it and other flying pigeons; all these being known by the name of Antwerp Carriers.

A remark occurs in THE COTTAGE GARDENER of August 19th, by "D," to the effect, that the pigeons of the Calaisis and Adresis show some resemblance to the Antwerp, and that the Blue-rock is rarely, if ever, met with. In this I perfectly agree; but I can assure "D," fancy pigeons are also to be met with, and the true Rock pigeon of Belgium is, I have every reason to believe, the real Antwerp Carrier, and their mealy colour is the prevailing one of the Belgian Dove-house pigeons—whence the similarity.

The true Antwerp resembles the wild Blue-rock pigeon of England in everything except colour; they are of a very light strawberry colour; rather darker, and inclining to red round the lower part of the neck, and having two reddish bars across the wings; the colour is what fanciers call mealy.

Some of these wild pigeons breed, I have been informed, in the church spires and towers of Antwerp, but they are, my informant tells me, so exceedingly wild, that they never mix with the tame pigeons, and cannot be caught; young ones are occasionally taken, and these retain much of their natural wildness although brought up by hand.

These pigeons I consider to be the source of our Antwerps; small wild birds, with very full round front to the head; the eyes gravel or orange-coloured, and very prominent; beak long, like a Rock pigeon, and colour mealy; some have a few black snatches on their feathers, and this is thought to indicate extra goodness.

They are exceedingly wild, and can rarely be brought to breed, except in their own homes, and if let out return there directly, though they may not have seen it for many months.

I am informed the breeders of them at Antwerp rarely

part with them; but when they do, rely on their returning, though they are brought to England.

It is surprising what distances they will return, and how little training they want, so that they would quite astonish our pigeon-flying gentlemen.

A variety of Antwerp, better known in England, are the short-faced Antwerps, also renowned for the long journeys they will perform.

In the Rhine provinces of Prussia, where I resided some time, the Turbits or Owls (for they do not discriminate between them there) were the only pigeons known as letter-carriers. Throughout Belgium these pigeons were at one time generally used as such (at least so I have frequently been informed), and, therefore, it is not to be wondered at that they should have been crossed with the true Antwerps.

This, then, I have not the least hesitation in saying, is the origin of the short-faced Antwerp. These are small pigeons with a short beak, more or less of the Turbit's gullet, and occasionally have a few feathers turned up on the chest something like the pearl of the Turbit or Owl pigeon; they are either blue or mealy-coloured; they are good breeders, and not so wild as the former, and as they are good flyers, and more easily obtained, are much better known here. A cross with these and the Dragoon is generally used for dispatches in England; they are larger, approaching more to the make of the Dragoon, with shorter beaks, and scarcely any wattle, and I think are generally liked better for short journeys; for as an old flyer of pigeons from Calais to Dover informed me, "he liked the half-bred birds best, as the Dragoons, put more sense into them; for the Antwerps often over-flew themselves in their short stages."

There are several other crosses of little note, and, therefore, not worth mentioning; but I believe they are all known by the name of Antwerps.—B. P. BRENT, *Bessel's Green, near Seven Oaks, Kent.*

FUNGI AS USEFUL PRODUCTIONS.

Nor only are Fungi despised as articles of diet, but as useful or even interesting productions they too usually either pass unnoticed, or are looked upon as objects the sight of which is rather to be shunned than sought after. Nor is this to be wondered at, when we allow ourselves to be guided by the prejudiced opinions of others, who, in most cases, have no real knowledge of the good or bad qualities of those things they are condemning. That such a large proportion of the whole vegetable kingdom should spring up (at two periods of the year when vegetation generally is most dormant) and flourish and decay without rendering man any service, appears to me unreasonable to expect; and that the same should be allowed to perish unemployed, year after year, I consider cannot be too much regretted. In addition to the importance of Fungi as an article of diet, many might prove of great value for a variety of purposes, independent of their interest as objects of beauty and curiosity.

As medical remedies, we are well aware that many of the most active species, formerly in great repute, are now rejected and forgotten; but that many are employed at the present day by eminent members of the medical profession, and are considered to surpass some of the more modern discoveries which, in some instances, have taken their place.

The *Lycoperdons* are used for a variety of purposes, as stopping blood, which they do mechanically by means of their spores; and stupifying bees, which is done by the smoke arising from them when burnt. Also, as tinder they have been much used, and for this purpose are saturated with a solution of saltpetre and then dried. In northern countries, where the neighbours live far apart, they have been employed to convey fire from place to place. *Polyporus ignarius*, and *fomentarius*, are extensively used in the manufactory of *Amadou*, which is used for the following purposes: for staunching blood; as a material for paper making; and steeped in saltpetre to form tinder; it is also made into dresses by the inhabitants of Francoid; is burnt by the Laplanders to protect their rein-deer from the attack of gad-flies; it is used for surgical pads; and when sliced, and formed into extensive sheets, it has been employed largely by the medical profession to protect

the backs, &c., of the bedridden invalids, as it is more elastic than chamois leather, and less likely to crumple. It has been considered far superior to many substances in more common use, also, for a compress over varicose veins, as it supports the distended vessels without pressing too tightly upon the limb. The Swedish peasantry use *Amadou* to alleviate pain as follows: Wherever they suffer pain, they bruise some of the dried *Fungus* or *Amadou*, and pulling it in pieces, put a small heap of it on the part nearest the seat of pain; it is then set fire to, and burning away it raises a blister on the skin; and, although this may appear to some persons a rough method of treatment, it is generally a very successful one.

Salmasius describes the following method of making *Amadou*: The *Fungus* is to be first boiled, then beaten to pieces in a mortar, next hammered out to deprive it of its woody fibres, and lastly, being steeped in a solution of saltpetre, exposed to the sun to dry. (I should imagine that the saltpetre was omitted except when it was required for tinder.)

Polyporus squamosus forms a razor-strop superior to many patented ones in general use, when prepared as follows: Cut it fresh from the Ash-tree, in autumn, when it has become dry and hard; flatten out and press for twenty-four hours, then slice longitudinally, and with a piece of pumice stone ground flat, rub to a level surface those strips which are free from the erosions of insects, which may now be glued upon a wooden stretcher, and when dry will be ready for use.

Polyporus annosus is reported by the Swedish peasantry to be a cure for snake-bites. *Polyporus sulphureus* is employed in dyeing. *Tremella mesenterica* is reported to dye yellow. *Tremella fimbriata* has also been used in dyeing; and the Russians employ for dyeing those *Boleti* which change to blue or green colour when cut. *Agaricus atramentarius*, and other deliquescent species, have been used in the manufacture of ink and dyes.

Phallus fatidus may be considered more as an object of interest than a useful production, from its quick growth and rapid decay. It passes through its ephemeral existence unnoticed; and probably the strong odour which it produces, which is far more offensive than putrid flesh, induces many to avoid rather than seek by such a guide one of the greatest curiosities of the vegetable kingdom. Flies, snails, and slugs, are so fond of it as to flock to its resting place to regale themselves with the delicious food it affords; and had not provident Nature supplied us with a root which, like the potato, throws off offsets, it would soon become extinct. The offensive odour it produces is very great when diluted with the surrounding air, but hardly perceptible when brought in close contact with the nose, and in this manner it may be readily conveyed home for examination. The odour has induced some to believe that the taste is nauseous and highly poisonous. Those, however, who are bold enough, may eat them without fear; and it has been asserted, that the white stalk is rather agreeable than otherwise. F. Y. BROCAS.

CROSS-BREEDING AND DISEASES OF FOWLS.

Your correspondent, "A. S. W., Glasgow," suggests, in your December number, no doubt with the amiable intention of terminating the hitherto unceasing war that has prevailed between "fancy men" as to the merits of Shanghaes, Dorkings, and other varieties of poultry, the propriety of crossing some of the best breeds, in the hope of producing a class of birds that shall combine the multifarious qualities of all. And he himself has made the experiment of crossing a Shanghae cock with a Poland hen, the offspring of which he speaks most highly of. My object in addressing you, is not to find any fault with his very laudable efforts to improve his stock by experiments of this nature, but to caution him as to the unsoundness of drawing any conclusions from a first generation.

Now it is a well-known fact among sheep-breeders, that nothing is more unsuccessful than the attempt to perpetuate the stock of a cross-bred animal. They degenerate to a marvellous extent with every succeeding generation, until at last the sheep become quite weak and sickly, having none of the characteristics of purity and health. Arguing from

analogy, the Shanghai and the Poland will generate stock which will gradually become worthless in the course of a few seasons. To have the cross perfect, every bird must be of the first generation; the parents of each "mongrel" must be of the separate breed, whose good qualities it is our desire to combine. I do not say positively that such deterioration will take place with fowls; but there is much greater reason, *a priori*, for believing that it will, than that it will not. Therefore, let us endeavour to persuade our friend, "A. S. W.," to give us the result of his experiments in a few years time, after he has tried to perpetuate the stock of his cross-bred birds from one generation to another.

Permit me, now that I have pen in hand, to say a few words upon a "Subscriber's" treatment of a poor hen, labouring under "inflammation of the egg-passage." I verily believe he killed it; and as he is anxious to know from your readers whether he could have devised any better plan of treatment, I venture to suggest (*medicus sum*) that he had better have left the poor creature alone. A warm bath for a fowl! Who ever heard of such a thing? Wet, cold, and damp feathers would undo all the good, if any, that a warm bath might have effected. If simply he had wrapped the hen in warm flannel, and placed it before the fire, without irritating the poor wretch with tartar-emetic, calomel, and rhubarb, this hen whom he now mourns might still have been the pride of the harem. I do most positively believe (and I hesitate not to declare it) that hundreds of animals of different kinds are yearly killed by the over-officiousness of their anxious possessors. There is a disease to which pigs are peculiarly obnoxious, bearing, with the vulgar, the elegant name of "the staggers." And, in my slight porcine experience, I have lost several by this, or rather by meddling with this, malady. Bleed him and purge him, say the learned. I have done so, and they have invariably died. But last summer, "the staggers" threatened my little farm-yard again. But no more bleeding and calomel for me. Keep him warm, and *leave him alone*, was my motto; and the only two pigs attacked recovered. This may be a mere accidental coincidence. I do not say positively that it is not. But still it has been a lesson to me; I will not meddle with Dame Nature any more. This position is equally tenable with fowls, and I am sure it is with humanity. More than half the people who complain would get well without a physician; but they *will* send for him; and, getting credit for spontaneous cures, like Belinda's Betty, the Doctor is "praised for labours not his own."—EDGAR SHEPPARD, *Enfield*.

[With what Mr. Sheppard says relative to cross-breeding, we entirely concur; but not so as to leaving poultry to "Dame Nature," if they are seriously disordered. Warmth and change of diet will usually do much for them, but we have seen too many cases of cure in all our domestic animals, not to know that medicine can do much in arresting the progress of their diseases. We wish any of our readers who have a hen egg-bound would try the effect of giving her ergot of rye. Three five-grain doses of the powder, mixed with a little meal and water, at intervals of ten minutes, might be sufficient.—ED. C. G.]

BOUQUET D'AMOUR.

THERE is but one step between the sublime and the ridiculous. No wonder the cook thought so; for I was in a towering passion one morning, to find the mince-pies spoilt *again*; not baked enough! and after such repeated tuition, striving to impress her with the tact and economy of the thing (*viz.*), directly the bread is taken out of the oven it merely requires a small quantum of fuel to engender renewed heat, sufficient for the baking mince, or any other fragile pies of that order whatsoever. Alas! for bachelors orders; "what should *they* know about orders?" * * * * * However, the mince-pies were not "half-baked," and the demon possessed the man. I dare not reiterate what I said on that eventful morning; but what I did, I state to my own shame and satisfaction.

I procured fresh wood in a fury; I caused the oven to become heated in a fury; and the oven roared; and I furiously roared at the cook, stentor-stating, that if she did not choose to make pies according to specification, and bake them properly,—a nice healthy brown, fit for christians to

partake of—so soon as *that* particular quantity of wood had exploded, I would come and do them myself!

Wonderful! Now I seriously think of it, it certainly was wonderful. The cook did make and bake some fresh pies beautifully, without retaliating a single word. No, she did not even shake her fist at me! I presented her with a glass of port in the evening; she deserved a bottle; but, as I was going to observe, in the height of all this hubbub, I strode with measured steps, though not slow, into the garden, thoroughly disgusted, wreaking anathemas, and as far as my recollection serves me, consigning cooks and bachelors establishments to the possession of all the caloric powers.

A change comes o'er the spirit of this rage. In one instant the tide of my vituperacious anger was turned to shame and sorrow; and how? Why, at that single love-beaming glance of a pure inoffensive flower, a Christmas rose, peering laughingly at me through a hand-glass, which I had placed over it as a protection from the winter storms. Often and often have I experienced the same fascination, become humanised as it were with this sweet fellowship; and I have more than once thought, if ever I should have the misfortune to lose my faculties, that the sudden presentation of a beautiful flower, would, in preference to anything, tend to the resumption of my reason.

The fair rose became at once endeared to me; it must be culled and placed by my fireside, and remain there cherished and loved for the future of its existence. I secured the humble admonitor, and communed with it, as I suppose most other people would do, who ever cull a flower with the like feelings.

A thought! Another!! It is done. I gently insinuate these Russian violets between each leaf of my Christmas rose, and secure their stalks to the rose-stalk tenderly with sewing cotton, introducing into the cup of the flower as many violets as can be pleasantly passed without very much distorting the petals of the rose, carefully allowing the pistil and stamens to remain fully exposed in the centre. I then procured the largest and most rounded violet leaves, and place them as a circled foundation directly beneath the white petals of the rose, when it represented, according to my idea, the appearance of a new and beautiful passion-flower; a bouquet, not for the hand, but worthy to present to a lady, and become secured on her bosom.

My interpretation reads thus—

BOUQUET D'AMOUR.

Evergreen as a foundation, enrayed with pure spotless white; centre true blue, with the gentlest sparkle of yellow (jealousy; and where is true love ever found without it?), showing itself in just proportion, by the peeping stamens of the rose.

I really think Covent Garden ought to sport this bijou; it should, and just possibly would, cause a run amongst the bachelors. My own sweet pet is wafting its odours in the desert of my solitary room, and chiding me even now.—F.

SINGULAR ATTACHMENT.

I HAVE a small white cockatoo, and a rough-haired terrier dog, which have formed a mutual attachment for each other; the affection of the bird is, however, perhaps the strongest. No sooner does the dog, who sleeps in the stable, make his appearance before the parlour-window of a morning, than the bird is all anxiety and restlessness to get at him; and when he is admitted into the room, she will fly down from her perch, and welcome him with the utmost delight, and testify her joy by expanding her wings, rubbing against his legs, and nestling herself as close to him as possible. He, in his turn, licks her over, takes her into his mouth, and is very careful not to hurt her. They lie together upon the hearth-rug, or upon a chair. When let out into the garden they gambol upon the grass-plot; and she attends him in his rounds about the premises. My sitting-room has folding doors, which are generally open most of the day during the summer, and the bird has free egress and ingress as she pleases, and being strong on the wing, much of her time is spent in the shrubberies, or on the tops of our highest trees. It is a beautiful sight to see her winging her flight along the face of the dark line of

foliage, or performing her evolutions high up in the air; at these times, when called to, she will suddenly make a turn, and with expanded and motionless wings glide down and alight upon the hand which is held out to her. She is very fond of attending upon her mistress when engaged in gardening; and if I happen to be at a distant part, will sail backwards and forwards, from one to the other, alighting upon our shoulders. Being light, her aerial movements are very graceful, far surpassing those of the common pigeon. She is also pleased at being noticed, and fond of strangers. That destructive propensity so often observed in the species results much from confinement, and is scarcely perceptible when they enjoy perfect freedom.—S. P., *Rushmere*.

TO CORRESPONDENTS.

FRUIT TREES (A Novice, Lutterworth).—The quality of fruits depends entirely on the localities where they are grown; and so, in some, *Beurre Diep* is only a second-rate pear, while in others it is of the very finest quality, as is the case with you. Generally speaking, in all situations south of Derby it is a first-rate fruit, rarely to be surpassed; but we know that in the northern counties it is only second-rate. We should not suppose the climate of Lutterworth unfavourable to the cultivation of Flemish pears; but from what you say of the "bottom" being dry, may in some measure account for your want of success. Although it is absolutely necessary for the cultivation of pears that the soil should not be wet, still, at the same time, it should be moist. There are some of these loamy soils you speak of, which have a dry gravelly bottom, that acts like a cullender in draining off every particle of moisture as it falls; and we suspect that is the disadvantage you are labouring under. It is not the climate, therefore, but the soil. You do not say whether you want dessert or kitchen Apples, we, therefore, send you four of each, as follows:—Kerry Pippin, Court of Wick, Wyken Pippin, Sturmer Pippin, Wormsley Pippin, Golden Winter Pearmain, or King of the Pippins, Dumelow's Seedling, Gooseberry Apple. The Pears we would recommend you are, Dunmore, Jersey Gratioli, Hacon's Incomparable, and Nelis d'Hiver.

SHANGHAE.—T. A. says, "I am still of opinion that there are no black or pure white thoroughbred Shanghae fowls in England, and should be glad, therefore, to know what may be Mr. W. Lort's, or his friends', 'powers to convince me of my error,' and prove that there are any of either. The word 'imported' is so commonly used in these days with reference to China fowls, that it 'goes for nothing.'"—Why does not our correspondent write to Mr. Lort?

GESNERA, SUTTONII ALBA (L.).—This, after doing well, came to stand still, and did not grow. On examining the roots they were found covered with mealy bug; what is the cause of this? We might write pages, and not be able to satisfy you or ourselves either. Most likely the bug came with the plant. You are fortunate that the vermin are confined to the roots, as such a nest was sufficient to give you trouble for years to come. If you are sure that none are on the top of the plant, and only there, take off a few cuttings to save the sort if you admire it; but that done, pitch pot and plant and all into the nearest fire you can reach, and that without a moment's parley. Even though you see nothing on the cuttings, wash them well with soap and water. The safest plan would be to sacrifice the whole. You could not have a worse intruder.

LANTANA MUTABILIS (T. A. E.).—You treated it as a greenhouse plant, and it is growing freely but not blooming. This we are rather surprised at. To grow freely at this season requires a warm greenhouse, such as that mentioned to-day by Mr. Fish. In such circumstances, and in a light position, it blooms as it grows. Treated as a greenhouse plant, it is most useful for summer blooming; and allowing it to become, in a temperature of about 45°, deciduous in winter. In March or April it should be cut back, as soon as you see the buds breaking, as freely as you would do a rose, shifted and kept close for a few weeks in a temperature not less than 50°. When removed to the greenhouse about June, it will bloom freely until the end of October. Full details as to greenhouse management have already been given. Loam, peat, and a little charcoal, will grow it in fine style. During the summer it may either be top-dressed with rotten dung, or watered alternately with manure and clear-water.

ORANGE-TREE (X. Y. Z.).—This is blooming, but lost all its leaves, and the twigs are getting mouldy, and fruit always falling off when the size of peas. This has been planted against the back wall of a greenhouse, in a border well drained; in soil, good loam, leaf mould, and sand; and watered occasionally with manure water. Now we must require to know more as to access to light and heat before advising; meantime, we would give no more manure waterings; next, we would examine the soil, and see first if it is not sodden, notwithstanding the drainage; and next, if it is not very dry after going a few inches from the surface. In either case we would replace with fresh soil, and peat for such a plant, might be substituted for leaf-mould. Then the position should be examined. We should almost conclude your plant was shaded in summer, and in a low temperature in winter. A plant can only endure the latter, and carry its foliage nicely, when it has full light and a rather high temperature in summer. To get an orange plant not only to flower, but to fruit, and be healthy against the back wall of a greenhouse, you must not only give it full light in summer, but a higher temperature than would suit most greenhouse plants, most of which would be better, however, in pits or out-of-doors. Then Mr. Fish gave full directions on this subject in an early volume; but the above volume, we think, meet your case; if not, tell us, and be more explicit.

EYED-NAILS FOR TRAINING WALL-TREES (T. Hill).—We did not say that your nails, of which we gave a drawing, would be more liable to

cause friction to the branches than others. One thing is quite certain; no gardener can fasten a branch so close to a wall by tying, as he can by the common mode of nailing with a shred. The branches, therefore, are liable to a freer and greater motion, and if the chaffing is not prevented, which would consequently arise if a wire is used, be not obviated in some way, no gardener will use them. We believe it would be obviated by using a strip of lead as broad as the eye would admit, and twisting the ends, thus screwing, as it were, the branch as tight as can be, by such a mode of training. In answer to your query, apply to a glass-dealer (we forget his name) within three doors of the Angel, Islington.

DUCKS (J. S. K.).—For a small garden buy a pair of Teal. You may obtain them of the dealers in fancy fowls.

NUTT'S CELERY (J. T.).—Why not write to Mr. Nutt for one of his shilling packets? He advertised in our pages a few weeks ago, and you will there see his address.

SHANGHAE FOWLS (A. B. C.).—We cannot answer for the goodness of specimens we have never seen. Price varies capriciously with amateurs. We saw specimens marked at one guinea per pair, at the Great Metropolitan Show, which we would have selected in preference to others priced by their owners at ten times the amount.

POTTING SAND (J. P. B.).—Our correspondent says that what we called "Killwing sand," at page 274, ought to be "Killiney sand," and he wishes it to be corrected, because "to numbers here (Dublin) the information will be equally valuable."

DORKINGS (J. B. F.).—Capt. W. W. Hornby, Knowsley Cottage, Prescot, Lancashire.

PARALYSED LIMBS (A Lover of all that is Handsome).—When a fowl loses the use of its legs, as in the case of your hen, we have never known any remedy that even mitigated the symptoms. We will recur to this case.

SPANISH FOWLS (A Subscriber, Leek).—The pure variety is single-combed.

CHALLENGE (J. C. D.).—If we inserted it we should have to pay the advertisement duty.

WORK ON POULTRY (H. H.).—See an advertisement to-day. The disease of which your poultry have died since their return from Birmingham must be some violent inflammation. We will mention the case again.

REMOVAL OF HOTHOUSE (L. Y.).—If attached to the wall, or to the foundation, it cannot be removed without the landlord's consent, but you might take away the door, and the moveable windows probably.

HEATING CUCUMBER-BED (Old Subscriber).—What is the heat in the pipe; and what the aspect?

DISEASE IN PIGEONS.—We are very much obliged by the following:—"Though I cannot inform J. T. of the cause of the disease with which his pigeons are affected, yet it may be acceptable to point out a means of removing it. As a boy, I kept pigeons in large numbers, and the disease J. T. alludes to was common among them; indeed, so much so, that I have removed the lumps from the neck of as many as seven birds in one morning. The plan I pursued, was to make a cut longitudinally over the lump, to scoop out the contents, and then to rub the interior of the wound with either tincture of iodine, or riga balsam, then at once securing the edges together. There was generally considerable bleeding at the time, and for that reason I preferred that my pigeons should be of some size and strength before I operated upon them. If the whole of the kernel was not removed, I found it grow again, and need a second operation. The doing this was not unattended with danger, the proportions of deaths being about two in five. I remember shooting some Wood-pigeons which appeared to suffer from the same disease, the flesh having the same peculiar rank smell, and being quite uneatable. I am now speaking of how I treated pigeons some years ago, and there may be now an easier or safer method, and if so, it must be known to our most celebrated pigeon-fanciers, whose addresses could be obtained without difficulty, and whose courtesy would, doubtless, reply to a polite enquiry."—A. LORT, *ward End, near Birmingham*.

FERN SHOOTS AS A KITCHEN VEGETABLE.—A correspondent (*Rector*) says, "I enclose you the following extract from Huc's Travels in Tartary. Will you be kind enough to say whether you have ever known the young stem of the fern cooked as a vegetable." (vol. 2, p. 86). "Another dish, not less distinguished in our esteem than the preceding, was furnished by a plant very common in France, and the merit of which has never yet been adequately appreciated: we refer to the young stems of fern; when these are gathered quite tender, before they are covered with down, and while the first leaves are bent and rolled up in themselves, you have only to boil them in pure water to realise a dish of delicious asparagus." Have any of our readers any experience as to the palatableness or wholesomeness of such a dish?

RURAL CYCLOPEDIA (W. W. W.).—We have never seen this work. We know where *Shanghai eggs* from the best buff strains may be had at eighteen shillings the dozen, package included.

ILLUSTRATIONS OF DOMESTIC POULTRY (Practical).—It is published at Birmingham; when ready for general distribution we have no doubt that it will be advertised.

NAMES OF PLANTS (G. A.).—Your plant is *Rochea falcata*, being named after La Roche, a botanical author. The spots or blotches upon the points of some of its leaves may be caused by changes the plant may have suffered, from too much watering at the root, or thoughtlessly over head with other plants. It should not be over potted. Soil, sandy loam, with pounded bricks, old mortar, or charcoal dust mixed with it, and the pots well drained, and kept upon a dry shelf near the glass; giving a very little water during the winter, and never over the leaves of the plant at any season. (N. T.).—We think No. 1 *Erica viridescens*. No. 2 *Erica acuminata*, but the specimens are small and damaged. (*Devoniensis*).—Your plant is the *Chianthus puniceus*, an account of which you will see in the Dictionary. We have it out-of-doors under a south-wall very full of flower-buds in a forward state at this time.

WEEKLY CALENDAR.

M D	W D	JAN. 27—FEBRUARY 2, 1853.	WEATHER NEAR LONDON IN 1852.				Sun Rises.	Sun Sets.	Moon R. & S.	Moon's Age.	Clock aft. Sun.	Day of Year.
			Barometer.	Thermo.	Wind.	Rain in In.						
27	TH	Dromius pusillus; bark.	29.588—29.467	46—29	S.	28	48 a. 7	38 a. 4	7 24	18	13 8	27
28	F	Demetrius atricapilla; bark.	29.883—29.730	45—21	N.W.	—	47	40	8 44	19	13 19	28
29	S	Hyphidrus ovatus; ponds.	30.090—29.924	46—34	S.W.	04	45	42	10 5	20	13 30	29
30	SUN	SEXAGESIMA SUNDAY.	29.979—29.624	53—29	W.	11	44	44	11 26	21	13 39	30
31	M	Hilary Term ends.	29.919—29.510	52—39	S.	14	42	45	morn.	22	13 48	31
1	TU	Podura plumbea.	29.996—29.717	57—39	S.W.	04	40	47	0m 47	23	13 56	32
2	W	PURIF. CANDL. DAY.	30.003—29.850	53—35	S.W.	04	39	49	2 10	24	14 4	33

METEOROLOGY OF THE WEEK.—At Chiswick, from observations during the last twenty-six years, the average highest and lowest temperatures of these days are 44.1° and 31.7° respectively. The greatest heat, 56°, occurred on the 28th in 1846; and the lowest cold, 10°, on the 2nd in 1847. During the period 101 days were fine, and on 81 rain fell.

ROSE-COLOURED TACSONIA.

(*Tacsonia sanguinea.*)



For a very full history of the genus *Tacsonia*, and the culture of some of its species, we must refer our readers to pages 5 and 316 of our fifth volume.

The species before us has been until now imperfectly known. About fifty years since it was described by Sir J. E. Smith, in Rees's Cyclopædia, as *Passiflora sanguinea*, and Decandolle, in his "Prodromus," first called it *Tacsonia*

sanguinea, but entirely from Sir J. E. Smith's description, and there is little doubt but that *Tacsonias quadriglandulosa*, *quadridentata*, and *pubescens*, in the same work, are really the *sanguinea*. It was first flowered in this country during last July, by Mr. Hugh Low, of the Clapton Nursery, and it is figured in the *Botanical Magazine*, t. 4674. Mr. Low received it from Trinidad, and the gentleman who forwarded it, H. Rye, Esq., called it *Passiflora diversifolia*. It is to be regretted that *sanguinea*, not being wholly inappropriate, must be retained as the specific name, for *diversifolia* (various-leaved) is descriptive of its very marked peculiarity of foliage, whereas "blood-coloured" is equally applicable to the flowers of some other species. The leaves vary in form, not only upon different, but upon the same plant, some being oblong-egg-shaped, and others heart-shaped, and three-lobed; the edges are always more or less wavy, and unequally toothed; the under-side strongly net-like, owing to the projecting nerves, sometimes downy, but always pale green, whereas the upper-side is always dark green, and usually smooth; the leaf-stalks are about half-an-inch long, with glands at their base, and sometimes in the waves of the leaves. Flower large, with five narrow, taper-pointed sepals, terminating in a pliable awl-shaped awn; sepals outside, partly green and rose-coloured, but inside uniformly rosy. Petals five, and like the sepals, but rosy-red on both sides. Crown, or nectary, double, short; the inner white, and membranous, fringed with red erect rays; the outer of a circular row of filaments or threads, white, banded and tipped with red. Column three or four times longer than the crown, with short threads, bent back, and the whole greenish, spotted with red. Anthers red. Styles deep red, with green stigmas. (*Botanical Magazine.*) J.

RESUMING our biography of the Pear from where we left off, at page 276, we will begin by replying to a correspondent's enquiry (*Norton*)—"On what grounds we say that the Romans had a very accurate knowledge of its cultivation?" We shall not stop to gather together the fragments of information sustaining our opinion, which we find scattered through the works of Cato, Columella, and Varro, but will turn at once to what is said by the brothers Gordian and Maximus Quintilius. They flourished in the second century, and in fragments of their writings, in the "Libri xx. Geoponicorum," we find that they recommend for the Pear a cool and damp soil, adding, that if the fruit is gritty, the soil should be improved, and well watered; a recommendation also given by Palladius. Diophanes, who wrote before Columella, Varro, and Pliny, for they quote from his writings, directs that they must be planted in a mild situation; that to promote fruitfulness, some of the main roots should be split, and the fissure kept open by a wooden wedge; and that if languid, they should be manured with the refuse of the wine-press. The Romans had their Mr. Rivers, or advocate for dwarf

Pears, for Tarentinus directs them to be grafted on the Quince (*Malum cydonia*). We might enlarge our extracts demonstrating that they knew how to propagate this fruit by cuttings, a lost art, but recently said to be re-discovered; however, we have quoted enough to justify our statement, and will at once proceed to examine what our earliest English herbal-writer, Dr. Turner, says about this fruit-tree.

In the second part of his "Complete Herbal," published in 1562, he remarks, "We have many kinds of garden Pears with us in England, and some kinds better than ever I saw in Germany for wholesomeness; and some in Germany more pleasant and greater than ever I saw in England. I have read in no old writer so many kinds of pears as I read of in Pliny, whereof I will show certain Latin names, and compare them with our English Pears and Dutch Pears as well as I can. *Pyra superba*, that is to say, Proud Pears, are little and soonest ripe; and these are called in Cambridge, Midsummer Pears. *Falerna pyra* have their name, saith Pliny, because they be full of juice. These are called, in some places, Watery Pears, or Moist Pears. *Dolobelliana* are the pears that

have long footstalks. I remember not how they be named in England. *Volema*, whereof Virgil makes mention in the second book of his *Georgicks*. These, because they are very heavy, as Virgil sheweth, and very great, as their name betokeneth, for they seem to have their name of *vola*, that is, the hollow place or loof of a man's hand, because they be as big as a man can grip in the palm or loof of his hand. These are commonly called in English, Wardens, if they have a binding and be red when they are roasted, and indure unto March or February. It appeareth that they have their name of long keeping; for Warden, in Dutch, from whence our English came, is to keep. *Serotina pyra* are they that hang upon their mother until winter, and were ripe with the frost. These are partly our Wardens, and partly other long-during Pears, which are called in Dutch, Winter Biren; and they may be well called in English, Winter Pears."

Next in order of time came Gerarde, who says—"The stock, or kindred of Pears are not to be numbered; every country hath its peculiar fruit. Myself knows one curious in grafting and planting of fruits, who hath in one piece of ground at the point of three-score sundry sorts of Pears, and those exceeding good, not doubting but if his mind had been to seek after multitudes he might have gotten together the like number of those of worse kinds." Johnson has altered Gerarde's arrangement of the Pears he specified, and they give the following as the ancient titles, and our Pears which are synonymous. Whether correct or not in that respect, they certainly shew eight varieties then known in our gardens, and some of which are still surviving. 1, *Pyrus superba*, Katherine Pear; 2, *Pyrus praeocia*, Jenneting Pear; 3, *Pyrus Jacobæa*, St. James's Pear; 4, *Pyrus regale*, Pear Royal; 5, *Pyrus Palatinum*, Bergamot Pear; 6, *Pyrus Cydonia*, Quince Pear; 7, *Pyrus episcopata*, Bishop's Pear; 8, *Pyrus hyemale*, Winter Pear. "All these," says Gerarde, "and many more, and those most rare and good, are growing in the grounds of Master Richard Pointer, a most cunning and curious grafter and planter of all manner of rare fruits, dwelling in a small village near London, called Twicknam; and also in the ground of an excellent grafter, and painful planter, Mr. Henry Banbury, of Touthill Street, near Westminster; and likewise in the ground of a diligent and most affectionate lover of plants, Mr. Warner, near Horsey-down, by London." It would not avail much now to seek for Pear Trees, either in Tothill-street or Horsleydown!

COVENT GARDEN.

SOME weeks ago, and for several consecutive weeks, we devoted our attention to the consideration of the more extended cultivation of the best varieties of Flemish Pears, and urged on our readers the importance of this new branch of rural economy. The more we think of the subject, the more we are impressed with the idea that it is one which must, ere long, engage the attention of occupiers of land in a way which it has never done before. We have already mentioned fully the varieties

which are best adapted for planting as standards; but, as stated last week, there is another aspect in which we must look upon this class of fruits, and that is with regard to their supplanting Peaches, Nectarines, and Apricots, in soils where these do not attain perfection or where a crop is so uncertain as to be always incurring suspense or disappointment. We stated in our last that we knew several instances which have lately come under our notice where these more tender fruits were rarely ever brought to perfection; and it appeared to us that the only object for occupying valuable wall-room with them could be no other than simply to have it said that such trees grew there. And in one of those very gardens, even so early as Christmas, there was not such a thing as a Pear to be had. A fruit-room there certainly was, but its shelves were occupied with a few miserable-looking apples, such as a costermonger would hardly exhibit on his truck. There are two causes which conduce to disappointment in the cultivation of the fruits of which we have spoken, and these are, soil and climate. It frequently happens that, even where there is a congenial climate, the soil is cold and heavy; and again, on the other hand, when the soil is all that could be desired, the climate may be cold, the summers short, or the situation exposed. Now, in all such cases, unless considerable expense is incurred, Peaches, Nectarines, and Apricots cannot be cultivated to advantage; and it is the space which these would otherwise have occupied that we wish to have appropriated to the more choice and valuable varieties of Flemish Pears, and particularly to those which come into maturity at a season when there is no other fruit to be had. We should imagine there are few who would not prefer a delicious melting *Passe Colmar*, or *Nelis d' Hiver*, at Christmas, to a poor, insipid, worthless Peach in September, and that, too, at a season when so much good fruit can be had without any trouble. All, therefore, who are labouring under such disadvantages as we have stated, we would counsel to abandon their present course, and occupy their walls with such varieties of pears as we shall now recommend.

In making out these lists we shall not include any of the early varieties. These can always be had in abundance during the early autumn; and as it is the late sorts to which the greatest value is attached, we would advise that they only should have occupancy of the wall.

FOR A NORTH ASPECT.—It rarely happens that Pears are ever placed in this situation. In all well-regulated gardens such an aspect is always employed with Morello Cherries, Currants, &c.; but, lest it should happen that there are cases where neither of these do succeed, a trial may be given to *Marie Louise*, *Hacon's Incomparable*, and *Thompson's*.

FOR A SOUTH ASPECT.—We have here an opportunity, on a south aspect, where the soil and climate are good, of enjoying these most delicious of the old French Pears, as the *Brown Beurré*, ripe in October; *Crassane*, ripe during November and December; and the *Colmar*, or *Poire d' Auch*, in use from November to February. For these the soil must be light and warm; in northern

parts the south aspect is preferable, but in the south they succeed well either on south-east or south-west walls. To those already named may be added, *Passe Colmar*, *Glout Morceau*, *Nelis d'Hiver*, and *Beurré de Rance*.

FOR AN EAST ASPECT.—In good situations in the south, *Passe Colmar*, *Glout Morceau*, *Forelle*, a delicious and most beautiful variety, sparkled like a trout; *Beurré Diel*, *Ne Plus Meuris*, *Nelis d'Hiver*, *Easter Beurré*, and *Beurré de Rance*. To which may be added, for more northern situations, *Thompson's*, *Knight's Monarch*, and *Hacon's Incomparable*.

FOR A WEST ASPECT.—There is no variety we know of does better on a west wall than the *Glout Morceau*. *Napoléon* also succeeds admirably. To these may be added the ever-to-be-desired *Passe Colmar*, together with *Marie Louise*, *Althorpe Crassanne*, *Hacon's Incomparable*, *Nelis d'Hiver*, *Easter Beurré*; *Jean de Witte*, a most excellent late variety, coming in between the *Easter Beurré* and *Beurré de Rance*. This deserves to be better known, and more extensively cultivated; it is one of Van Mons's best varieties. The *Beurré de Rance* should also have a place here and everywhere else where it will succeed.

This is a subject to which we shall have occasion to recur again; but, as the season is now rapidly advancing, and all planting work should now be seen after, we have considered it advisable to furnish our readers with a list of the best varieties for wall culture, that they may lose no time in making the necessary preparations.

The trade of Covent Garden is now even worse than it was before Christmas. Every description of produce is most abundant; indeed too much so, there not being buyers sufficient for the supply. These remarks refer to VEGETABLES. *Savoys* are making from 6d. to 1s. per dozen. *Brocoli* has been very plentiful, bundles containing as many as twelve heads, fetching no more than from 3s. to 4s. per dozen. *Greens*, 1s. to 1s. 9d. per dozen bunches. *Brussels Sprouts*, 1s. to 2s. per half sieve. *Turnips*, 1s. to 1s. 6d. per dozen bunches. *Carrots*, 2s. 6d. to 3s. per dozen bunches. *Celery*, 6d. to 1s. per bundle. *Onions*, 3s. per bushel. There is still a good supply of forced *Rhubarb* at 1s. per bundle. *Sea-kale*, 1s. to 1s. 6d. per punnet. *Asparagus*, 5s. to 8s. per bundle. *New Potatoes*, 6d. per lb.

In FRUIT the supply is short. APPLES are rising again in price; very ordinary samples of culinary sorts make from 4s. to 7s. 6d. and 8s. per bushel; and dessert varieties as much as from 7s. 6d. to 14s. Those which produce the latter price are the *Golden Knobs*, a fine little russety apple, which is grown extensively in Kent, and which do not come to market till about this time. This would be a profitable variety for orchard planting; not but what there are many which are far superior to it, but being a good keeping sort, it comes in at a season when there are few good kinds in the market.

The supply of PLANTS and FLOWERS is good, and the demand is brisk. They consist of *Camellias*, *Heliotropes*, *Hyacinths*, *Polyanthus-Narcissus*, *Tulips*, *Chinese Primroses*, *Lily of the Valley*, *Acacias*, *Cinerarias*, *Euphorbia Jacquiniiflora*, *Azalea indica alba*, &c. H.

GOSSIP.

MR. BAILEY informs us that the statement at page 251 is incorrect, and that he did not send a catalogue of the Birmingham Show to the party alluded to. He says, moreover, that he did not see a catalogue until after he had inspected the birds as a judge, and given his decision. This we are very glad to know; but we have the fact confirmed that catalogues were circulated before the day of exhibition, which is one of the chief errors which we would bring to the notice of all committees of poultry shows.

The following observations by Mr. Whiting, published in the last number of the Journal of the Horticultural Society, deserve especial and general attention. We are inclined to agree with Mr. Whiting in the opinion that our variable climate is the cause of the *Peach's* early decay on our walls, and we consider the gumming, and death of large branches to which the *Moor Park Apricot* is so subject, is a consequence of the same cause. This opinion is founded upon a statement made to us by the Rev. Mr. Beadon, President of the Hampshire Horticultural Society, that he knew cases in which the *Moor Park* had been for many years preserved from such injuries by binding hay-bands round the stem and branches, at the close of autumn, and continuing on those bandages during the winter. Mr. Whiting says:—

“It is clear to me that the variableness of the climate, coupled in some cases with a deficiency of attention, chiefly in spring, has more to do with the early decay of our wall peach-trees than either the unsuitableness of the plum-stock, or the present method of pruning the trees. In confirmation of this opinion, look into our peach-houses, where an old tree is not so great a rarity as it is against our walls, and yet in both cases the stocks and the pruning of the young trees are alike. Under glass, however, the tree enjoys a genial climate, and also the further advantage of better general management. There, want of space for the lateral extension of the branches is the greatest detriment the trees have to encounter; and if at the time of planting they were so arranged, that one tree might, if necessary, eventually occupy the whole area of the roof at eighteen inches or two feet distance from the glass, I see no reason why a peach-tree, even though pruned with a knife, and budded on a plum-stock, might not live and thrive for an indefinite number of years.

“As regards the apricot-tree, Mr. T. A. Knight entertained a notion that the short duration of the *Moorpark* trees arose in a great measure from its unnatural connection with the plum-stock; and many years ago he pointed out to me, in his own garden, the greater healthiness of a particular tree on an apricot-stock than that of another tree growing beside it which had been worked upon a plum-stock. As the apricot does not thrive in the light sandy soil of this garden, I determined upon trying Mr. Knight's plan, and with that view I sowed a few stones of several sorts of apricots. Four young plants thus obtained were planted against a wall, for the purpose of being budded with the *Moorpark*; finding, however, that they exhibited unequivocal symptoms of a delicate constitution, I did not bud them, but trained their branches to the wall till they produced fruit. One of these trees is a genuine *Moorpark*, and already some of its principal branches have perished by that peculiar disease which detracts so much from the value of the otherwise excellent variety; thus proving that misalliance is not the cause of the disease in question. Of the other trees, one is a *Breda*, one an orange, and the third an inferior variety of *Moorpark*; this last also shows symptoms of the same malady. This experiment seems also to show that some varieties of apricot can be reproduced from seed.”

There is no reason assignable why the *wines made at the Cape of Good Hope* should not be equal, or even superior to those produced in any other part of the globe; and, indeed, from the evidence of palates from which there need be no appeal, we know that wines equal to the finest white wines of Spain have been there manufactured. We believe that the sole cause of the usual low quality of the Cape wines is carelessness in their manufacture. This opinion we find confirmed by the report of the Wine Committee of the Cape Town Agricultural Society. It is there stated that the samples presented last year are considerably superior to those previously produced. We are sorry to hear that the funds of that Society are so low, and if there are no errors in its management, we are quite sure that government assistance could not be better directed than towards its support.

THE following is a list of the *Poultry Shows* of which we are at present aware. We shall be obliged by any of our readers sending us additions to the list, and giving the address of the Secretaries.

REIGATE, February 1st and 2nd. (Sec. J. Richardson, Esq.)

THE POSITION OF FRUIT TREES IN THE NEW YEAR.

THE past winter, if such it may be called, has been of such singular character, that I would advise all fruit growers to be on their guard.

Peaches, Nectarines, &c., here, are in such a forward state now (January 4th), that we have deemed it expedient to cover them instantly with the canvass so often alluded to. The buds are already in the condition of being rubbed off with the least friction, and cannot be expected to withstand some fifteen or twenty degrees of frost, which is something more than a mere possibility.

What, then, is to be done? My opinion is, that the only chance will be in pruning somewhat later, somewhat lighter, and in covering the trees during all sunshine, and all hard frosts, and uncovering to the chilling breeze and the cloudy day. As to late pruning, it may be called in as an accessory that may prove useful, and in this wise:—early pruning, by confining the range of the sap in a narrower compass, by consequence increases its impetus, and has a tendency to force out the back buds somewhat earlier—a thing, under present circumstances, by no means desirable. In thus offering an opinion, I would not have it inferred that such falls in with the new idea of its being a prudent course to protect *the wood* of fruit trees from frost every winter. This new practice, so strongly urged by some, had originated, it would appear, with Mr. Barron, at Elvaston, a gentleman whose high name would certainly appear an authority for almost any gardening practice. However it may have succeeded with him, or others, I cannot say; I have so often known full crops of first-rate fruit after intensely hard winters, that it is not here where the shoe pinches. The public, after all, is a very changeable creature: Proteus-like, or as the chameleon, it is not always to be seen in the same form or colour. But these are days of experiment, and sooner or later, the cauldron being kept constantly boiling, the scum arises, and we come to the pure article. I allude here to the fitfulness which has

attended the progress of the question of protection, not governmental, but horticultural, and as concerns the fruitist. Mr. A. says, "Cover not at all. I lost all my peaches and apricots last year by this artificial procedure." Mr. B. says, "Depend upon it, it will not do to leave trees to accidental extremes, and dignify them with the high-sounding title, 'Nature.'" Mr. C. will not only cover to protect blossoms, but the very wood of the trees when in a state of dormancy; and Mr. D., who is a decided utilitarian, begs to know who is to find the protective material?

We had a saying in early days, that "it's all very well to talk of flying kites, but who is to find pack-thread?" And, indeed, so much of this covering is very expensive, especially if on for many months. As for straw, ropes, and all such things, they are quite unworthy the age; besides, these mightily concern the labour question, and it is certainly all very well for those gentlemen who are so fortunate as to get what amount of labour is really desirable; but what becomes of the rest? It is of no use saying, men can make them in bad weather; every gardener knows that in-doors work has increased in a somewhat similar ratio to out-doors labour during the last twenty years; certainly, those practitioners who buy all their brooms, baskets, &c., instead of making them, as we countrymen are obliged to do, may spend much time in twisting straw ropes. I really, therefore, feel little desire to see the straw system become general, feeling assured that, when all things connected with them are duly estimated, there is no real gain—indeed, the very reverse.

But then, the question arises—If trees *must be covered*, what is best and most economical in the end? And really, if the public is prepared to build such expensive things as glass walls, surely it will not stumble at the question of a cheap canvass! I may here observe, that it is matter of great astonishment to me, and others, that a still better material has not been produced, seeing that our textile fabrics have, in general, attained so high a position. Canvass only needs an increased durability, and the world is not now confined to mere hemp for such purposes. There is no question but an ingenious man would speedily realise a fortune, could he produce an article combining the desiderata of the horticulturist.

Thus much for a hint as to progress. Let us get back to the fruit-tree protection, as to our present position. Canvass, then, at fourpence per square yard—for which price, I have little doubt, it could be had for in quantity—is at present the most eligible; and this, fitted to a given length of walling, and confined to that purpose, will last for seven years. But then, it ought to be fitted up by a mechanic in the first instance, or, ten to one it is worn out in half the time by imperfect action.

Now, as nobody, in these days, of any repute, will doubt the immense utility of copings—moveable copings, why not have these wide enough to receive canvass on a roller, somewhat after the manner of the Metropolitan orchid houses? By such means, the canvass might be kept generally dry, and consequently wear the longer. I merely throw out this as a hint for those it may concern; those determined to go a-head, and who are not to be baffled into unworthy practices by an unjustifiable fear at the first outlay, which fear, by the by, has ruined many a well-concerted plan.

However, whatever plan, get, we say, the trees covered immediately, but not with the intention of coddling them; but remember, that if the trees have been neglected in the previous summer, if their wood is badly ripened, do not blame protection: no covering can render such a condition satisfactory. As before observed, it is in the *use* of protection I confide; it is quite possible to prove an abuse.

Let the trees be unshaded on all possible occasions,

remembering that with dark coverings, and the bud in an expansive state, what is termed "drawing," by practical men, will take place; and the best way to put this practical technicality into plain English, is to call it "weakening"—weakening the functions of those parts in course of expansion and development, on which not only the fruiting tendencies depend, but the very energies of the unfolding wood-buds from which future crops should be raised.

As an ordinary maxim, I may add, withdraw your canvass at least every second day, unless some serious reverse of weather take place. But our readers will very naturally desire to know what is meant by reverse; what the trees *will* endure, and what they *ought not to be compelled* to endure. First then, our wall trees, in general, will endure unharmed, under ordinary circumstances, some ten to fifteen degrees of frost, until their buds are actually swelling. I do not, of course, speak this irrespective of condition in the tree, for it may have been a late wet and glutting autumn, the trees rather gross, and all their vessels gorged with watery matter. It need scarcely be observed here, that the more succulent the habit, the greater the chances of a rupture of the vessels and delicate structure of the wood. These remarks are intended to apply to ordinary winters, and trees under ordinary circumstances.

To proceed, the trees, up to the time of the real opening of the bud, or when the very first symptoms of the interior and more delicate parts appear, will endure any amount of what are termed cold winds, providing the thermometer does not indicate above three or four degrees of frost. Indeed, I prefer these refrigerators, welcoming them in the character of retarders; but if wet comes on, the case becomes slightly altered; a modification of practice is then requisite. If, unluckily, your man is caught napping, and has left the canvass off under the pressing and doubtful circumstances here alluded to, and you discover early the next morning that your unfolding buds are sealed up with an icy covering, my advice is, take care that the sun does not shine on them; canvass them over directly, and if your wood has been ripened well, fear not.

To meet all difficult cases, such as appear in the inquiries of anxious fruitists, young in experience, but old in emulation, would be to write a big book, which few would have patience enough to carry a mile on their shoulders; and shall I say, fewer still have time or patience to read. "Touch and go," is the motto in these days; and all I can add is, let all interested study a little those principles to which the mind is here directed.

R. ERRINGTON.

BULBS.

(Continued from page 303.)

CALOSTEMMA.—This is a genus of very pretty Australian bulbs, belonging to the Pancratioid section of Amaryllids, and requiring about equal quantities of peat and yellow loam, with a little sand, to grow them in pots; but they will grow and flower out in a warm border during the summer, and increase themselves by offset bulbs. The flowers are not individually large, but the colours are gay, and there are many flowers in each head or umbel. The cup, to which the stamens are joined, is nearly up to the middle of the flower, and the edge of it is fringed round with triangular teeth; it is from this frill it has been called the Gay Crown, or Calostemma. The stamens rise only a little way above the edges of the frilled crown, and they carry small erect anthers; these, with a sharp-pointed style in the middle, add much to the significance of the name.

CALOSTEMMA PURPUREUM.—This is a rich purple flower; and when the bulb is strong, and in good con-

dition, there will be from fifteen to twenty flowers in one head (umbel), and each flower has a short footstalk (peduncle). The flower scape, or the stem which carries the head, is about a foot long, and the leaves a little longer. There is a midrib to every division of the flower in this genus, which is continued down to the seed-pod; and in this species the rib is as purple as the rest of the flower.

CALOSTEMMA LUTEUM.—A very pretty thing, but very scarce. Yellow flowers, with green midribs, and a rich purple at the bottom of each division of the flower, about the same size as the last; but this and the next require more sand in the compost than *purpureum* if they are grown in pots.

CALOSTEMMA ALBUM.—A much scarcer bulb even than the last, from which it differs only in the colour of the flower, unless, perhaps, that the fringe on the cup has the teeth a little sharper and smaller.

CALOSTEMMA CARNEUM (Flesh-coloured).—This is another very pretty plant, and is more hardy than the others. The flowers are bright pink, and about the same size as those of the others. From all appearance, and from our knowledge of kindred plants, there is every probability that the whole four will cross with each other; and if they do, they promise as much diversity as the *Gladioli*. Sir Thomas Mitchel found this species on the summit of a chain of rocky mountains; he sent it to the Horticultural Society, in whose garden it flowered here, for the first time, about a dozen years back. There is another species called *Cunninghamii*, but I know nothing of it.

CARPODETES.—The accent is on the *o*. There is only one bulb in this genus known to us—a native of Peru, near Obregillo, in the province of Canta, where the natives call it Chihuanhuaita. It is figured in the "Flora Peruviana," where it is called *Pancratium recurvatum*. In those days every flower of this form was called a *Pancratium*, just as we might say to-day that a Tulip, a Hyacinth, or a Fritillaria, is a Lily. This bulb is middle-sized, oblong, and with a long neck, purplish, with black spots. The leaves are an inch wide, and ten inches long, and blunt at the point; the flower scape is stout, shorter than the leaves; the flowers are between purple and yellow, and the seed-pod is narrowest in the middle—a very unusual shape, so that the whole plant is easily known. Pure yellow loam, with a little sand, suits it best. It is a summer-growing bulb, which increases slowly by offsets, and is more safe in a pit.

CARPOLYZA SPIRALIS.—This is one of the smallest bulbs which belongs to the order of Amaryllids, and one that has puzzled more learned heads than any of them. Jacquin called it *Crinum tenellum*, but it bears the same relation to *Crinum amabile*, as the *Ægilops* does to the Talavera wheat. In the "Botanical Repository" it is called *Crinum spirale*. Le Heritier makes it *Amaryllis spiralis*, and the younger Linnæus calls it *Hæmanthus spiralis*, in the "Hortus Kewensis." As late as 1834, it was named *Strumaria spiralis*, in the "Botanical Magazine." Dr. Herbert, commenting on all this confusion, very justly remarks, "when each successive writer refers a plant to a different genus, as in this case, it may with great probability be surmised that it belongs to none of them;" and so it turns out with this one. *Carpolyza*, which is now adopted by common consent, was the name given by the late Mr. Salisbury, in his "Paradisus Londinensis." The flowers of this little bulb are very pretty, star-shaped, blush-white inside, and pinkish outside, quite pink in the tint; the scape carries two or three of them, and they are about the same size as those of *Anomatheca cruenta*; the leaves are not much stouter than those of a young onion three weeks old, and much in the same way, curiously twisted; the bottom of the scape has also three or four turns of twists, for which it is called *spirale*. It is a native of the Cape

of Good Hope, growing near Cape Town. With the exception of *Griffinia hyacinthina*, it is the only bulb in the order that will grow better in peat than in loam. It flowers in the autumn, before the leaf, like a true Amaryllis, and grows through the winter like an *Ixia*, requiring the same kind of treatment in all respects.

CHLIDANTHUS FRAGRANS.—This is a yellow-flowering sweet-scented bulb, which is as much prized in the gardens in Buenos Ayres, Chili, and Peru, as any of the Narcissus tribe is with us. In its outward aspect it is not much unlike some kind of yellow Narcissus, but it belongs to the Paneratioid section of the order, although hardly any traces of the cup is seen. If there was a good demand for this bulb, they might increase it almost as fast as the potato, it is so notorious for making offsets, so much so, indeed, that they hinder the old bulb from flowering. It is a summer-growing bulb, and flowers freely with us in the open air; it will not stand out our winters, however, as the wet border splits the old bulb. It should be taken up in the autumn and dried. The very same treatment we give to *Gladiolus psittacinus* is best for it. It is not the *Paneratium luteum* of the "Flora Peruviana," as has been asserted. (See *Clitanthus*).

CHORETIS.—We know only two species of this genus, and two beautiful things they are, certainly; but how the learned demonstrator of the order, Dr. Herbert, could see any difference in them from *Hymenocallis*, passes my comprehension. The anther turns up a little at both ends, just like a school-boy's "pot-hook," and is attached to the filament a little nearer the upper end than is usual in *Hymenocallis*, and there is a little difference in the shape of the seed, that is all. However, I must keep to my text; I have no desire to change a name, but I must be allowed to make some few remarks from the evidence of my senses, and I shall show my ideas on *Hymenocallis* when I come to it.

Choretis inhabits the north-eastern parts of Mexico, and onwards through Texas, where Drummond met with them growing in good loamy-soil; but in pots they delight in a rather sandy-soil, and abundance of water; and I have not the least doubt that, if we had a good stock of them, instead of being very scarce, we might turn them out in May into the margins of the ponds and ditches, where they would grow and flower as freely as rushes.

CHORETIS GLAUCA has the leaves upright, sea-green, nearly three inches wide, and twenty inches long; the flower-scape is stout, and above a foot long, carrying three or four flowers on the top; the flowers are sessile; that is, without a footstalk. Every Amaryllid that is sessile, like this, must have the seed-pod resting on the top of the scape; from the seed-pod of this *Choretis* rises a green tube, full six inches long, longer than the tube of the Night-blowing Cereus (Cactus), then a wide open flower nearly four inches across, as white as a lily, with a tinge of green on the back of the midribs, and a large green eye. The cup inside is also very large, white, and jagged on the edge between the stamens. Altogether, it is a very beautiful flower. The bulbs may be kept dry six months, from the end of August to March.

CHORETIS GALVESTONENSIS (Galveston Bay, Texas).—Another fine plant, in all respects like the last, only with all the parts much smaller, and with deep green instead of glaucous leaves, also four flowers always on a scape.

CLITANTHUS LUTEUS.—This is the *Paneratium luteus* of Ruiz. It has much the aspect of a small Narcissus, with yellow flowers, and always two of them on a scape; the flowers are stalked (pedunculate), the stalk above an inch long; then a round seed-pod, and a yellow flower with a longish, small tube, evidently very near *Chlidanthus*, and if the two would breed together, the

offspring would be more entitled to be called Peruvian Daffodils than *Ismene*. Before 1840, this genus was spelled *Clinanthus*, but that is now discarded, as giving a wrong meaning. There are two more species, *humilis* and *Macleana*, but I know nothing about them.

CLIVIA NOBILIS.—A well-known plant from the Cape, with the looks of a young Agapanthus, but with stiffer leaves, and with turned-down flowers from the top of the scape (Cyrtanthiform). This is of the very simplest culture, if you keep it from heat, and do not force it into any hurry. It will grow in any light earth in a pot. You might try all the mucks, from the Lobos Islands to the Isle of Dogs, on it, without any perceptible effect. It will grow well in moss without any earth; and it will grow in any light or heavy compost, if it is kept rather dry in winter. Whenever it gets sulky, and refuses to grow, you must shake all the soil from it, and begin afresh: there is no doctoring of it. If you keep the frost from it, in an outside border, it will flower and ripen seeds freely enough. I had it so, and it took more than a year to ripen its scarlet berries, which look exactly like the ripe seeds of Asparagus. Seedlings of it would tire one's patience with their slow growth; and if you try to force them, they are as likely to stand still as not. Dr. Herbert said, "I believe it to be as possible for a *Clivia* to breed with a *Cyrtanthus*, as with an Oak-tree;" but I differ from him, and from all who separate it from the vicinity of the *Cyrtanthi*.

COBURGHIA.—This is "a happy family" of bulbs, they so agree with each other in their odd ways. If you ask a gardener what sort of things they are, he will say, "Peruvian bulbs, very beautiful, ma'am; very easy to grow; too easily increased—the worse luck; not very fond of water, or particular about soil; not over partial to a bright sun, it is true; but there is so much bother with them, as they go to rest all the winter; and you can begin them in the spring any time it is convenient; and then, you see, if one is pinched for room, as we generally are in the spring of the year, we can plant them out on a warm border, and they will grow all the same." "Yes, yes; but now I do not know what kind of flowers they produce." "Nor I, ma'am; for I never could get them to blow." There is not a gardener in the kingdom who has flowered the same bulb of any of the species of *Cobourghia* three years in succession, and yet they never refuse to flower the first or second year after they come over. In Mexico, and other Mexican cities and towns, they grow one of the species in pots, as we do Hyacinths, time out of mind, and in such numbers that an erroneous idea has got into our books that it is a native of Mexico; but I have never heard of any of them being met with there in a wild state; and J. Maclean, Esq., a British merchant at Lima, dug up the one they cultivate in Mexico on the hills facing that part of the Peruvian coast; and he found some of them growing in scanty soil, on the edges of rocky precipices, where great heat and terrible gusts of wind must often affect them. The way I recommend their cultivation is founded on the following experiment on a variety of bulbs of this nature. On a slate stage, along the front of a greenhouse, which was freely ventilated day and night all the summer, I placed an inch or so of sandy soil the whole length, with another inch of clean white sand on the top; I had two objects in view with this bed, which was about twenty inches wide, and twenty-four feet long, to keep a damp bottom for pots, and to place a lot of obstinate bulbs between the pots, among which was one of *Cobourghia incarnata*. The bottom of the bulbs were on the bare slate, and a little extra soil placed round them to keep them firm. The drainage from the pots kept the soil constantly wet, and sometimes, in very hot weather, a quantity of water was poured in between the pots. The roots travelled rapidly along the slate, the leaves went off equally

strong, and soon had to be supported. In September the *incarnata* threw up a strong flower scape very nearly two feet high, and carried five splendid flowers. *Leucocoryne ixioides*, another very obstinate bulb, flowered on this stage, with several others that are now better understood. It is very easy to imitate this in a division of a cold frame, or out under a south wall, by placing very soft bricks under a thin bed of very rich loam, and attending to the constant moisture. The soft bricks would be much better than the slate, and the roots would cling to them like ivy to a wall. The heat would be scorching in the height of summer, but that is just what a vast number of bulbs from South America and Southern Africa seem to require in our climate, which is quite warm enough for their leaves and flowers. I know at least fifty as fine bulbs as one need want to grow, that would answer on this plan better than on any other that I could devise.

COBOURGHIA COCCINEA.—This beautiful bulb was first discovered by Matthews, who sent dried specimens of it to this country. Mr. Maclean was the next who found it, "in one of his excursions on the Cordilleras." He sent two bulbs of it to Dr. Herbert, and they soon flowered with him in pots, and in strong loam and rotten dung; the pots stood out-of-doors all the summer of 1839, which was cold and wet, were kept dry all the winter, and early in the spring, before the leaf, both of them flowered. In 1840 they went through the same treatment, and one of them flowered the same autumn, after the fall of the leaf. The flowers are like those of *incarnata*, but shorter, and a better scarlet. All the species have dark green tips to the lobes.

COBOURGHIA FULVA (Tawny).—Matthews sent dried specimens of this, also from Lima, and J. Wilmore, Esq., of Oldford, near Birmingham, was the first to flower it. The tube of the flower is full three inches long; the colour, a dull yellow mixed with grey and brown, with the usual green tips.

COBOURGHIA INCARNATA.—This is the species on which the genus was founded by Mr. Sweet. It was figured, before him, by Kunth, and called *Pancretium*. It is a native of Quito, growing on the banks of the river Machangara. The leaves are milky-green, the tube of the flower five inches long, the colour deeper than the word *carnea* would imply, more crimson, and the lobes blotched with green; it is a fine thing.

COBOURGHIA TRICHROMA (Three-coloured).—This was a puzzler for many years; no one knew where it was a native of; but it was extensively cultivated in pots in the city of Mexico, as we do Hyacinths, time out of mind. From this it is called "the Mexican species," in books; but it is a true Peruvian, and as bad to get to flower here as any bulb we know. Mr. McLean had it dug up on the Andes. The flowers are not so long as the above; the colour is light scarlet, the lobes edged with a paler colour, and a streak of green runs down the centre of each lobe, instead of the usual green blotch.

COBOURGHIA STYLOSA.—*Osus*, or *osa*, in our language, means a greater degree, or excess. Style is the female organ, and *stylosa* means it to be longer than is usual in this genus. Without the flowers this looks very much like *incarnata*. It is also from near Quito, where M. Harting found it, who sent it to the Horticultural Society. The flowers are as long, and larger in the opening than those of *incarnata*; but the colour is very different—indeed, peculiar—a dark greyish-green all up the tube, extending along the midrib of each division, which are otherwise rich orange-red; or, in other words, the colours in this species are reversed from the usual run in the genus.

COBOURGHIA VARIEGATA.—This is a handsome flower, and a great favourite with them in the gardens about Lima; but where it is growing wild I never heard. It is the only one of them which was met with by the

authors of the "Flora Peruviana," who called it *Pancretium*, of course. All those flowers with a cup inside, to which the stamens adhere, were supposed to be *Pancretiums* in those days.

In addition to the brick-floor, I would advise the offset bulbs to be destroyed by twisting a sharp-pointed stick through the middle of them, or by pulling them off as soon as they can be laid hold of. They certainly hinder the flowering of the bulbs. D. BEATON.

(To be continued.)

PROPAGATING TENDER AND HALF-HARDY PLANTS.

THIS chapter, without embracing all points of an interesting subject, and which, before long, will be engaging great attention, is written solely to meet the inquiries made, and the explanations that have lately been deemed necessary. The following questions will not only embrace the wants of correspondents, but I hope may be interesting to new beginners in general:—

1st. "Is air to be admitted to fresh-made and newly-planted cuttings placed in cold frames?" We frequently receive many questions, evidently from intelligent people, well versant with the principles of some of the exact sciences. They are accustomed to see some one primary principle regulating the whole routine of practical detail, and becoming somewhat enthusiastic in gardening, they very judiciously wish so far to see their way, as to be able to refer to a definite principle as the basis on which their operations are to be founded. These are the people that, if they persevere, will ultimately make the most successful gardeners. But, trusting too much to any one general principle, such people are too apt to "give up" from a disappointment, just because, though a principle be sound, the modes of its application *may* be, and *must* be, as varied as the nature, the habits, and the circumstances of the plants to which they are applied. Hence, as a general principle, it may be stated, that for growing cuttings with their foliage on, or even partly reduced, a minimum of air, and either shaded or diffused light, are necessary, just because a current of air and exposure to light would rob the cutting of its juices; on the saving of which the future processes of rooting and growing depend. On one hand, therefore, the more successful you are in keeping your cuttings from flagging, by checking the air and light, the sooner will roots be formed; but, on the other hand, you may keep so close in a moist atmosphere, may shade so well from the sun, or place the cuttings at such a distance from the glass, that the material of your cuttings will be exhausted in upward growth, and thus you may either get no roots at all, or, very likely, be rewarded with a sickly, drawn, leggy young plant. While closeness and diffused light are thus generally indispensable at *first*, it is no less necessary to give the cuttings air and light as soon as they *can* bear it. No royal rule can here be given; every case must be regulated according to its peculiar circumstances. For instance, *here* are succulents, such as *Cereus*, *Mesembryanthemum*, *Crassula*, &c.; who would think of keeping them shut out from air by placing a bell-glass over them? Roots, in their case, will generally be formed long before air and sun combined have taken away, by evaporation, the stored-up juices. *There* are Geraniums and Pelargoniums, which will strike as well in the open air in July, as they would do with all the paraphernalia of lights and shading. But try a Heath, or an Epacris, or a Chorosema, by such means, and you may wait, and cry until you were hoarse for a plant to come. Then, the same plants, as respects the cuttings from them, require different treatment at different times. The ripening

shoot in the autumn will stand more air, and rougher treatment, than the soft, spongy, watery shoot in the spring. In the one case, growth is being *arrested*, in the other, it is being *excited*. Apply, in the first case, and at once, such stimulus as a warm, close, shaded atmosphere, and in many cases you will get shanked cuttings and rotten tissues for your reward. Apply such excitements when growth is progressing, in spring, and with the extra care for securing a close atmosphere and a diffused light, you will be paid in obtaining plants in a seventh part of the time you would do in the autumn. Two general rules may, therefore, be deduced from a primary principle. First. Do not hurry cuttings inserted in *autumn*; let them have time, and as much air and light as they will stand without flagging. Second. Never allow cuttings inserted in *spring*, or early summer, to receive a check if you can prevent it. In their case, little or no air should be given during the day, until roots are produced, and then it must be given at first in small quantities. Cuttings, as well as plants, must have their atmosphere changed at times. For preserving healthy robustness, and warding off insidious damps, I have long practised, and recommended, giving cuttings a little air at night, less or more, according to circumstances.

2nd. "*What is the use of bell-glasses?* Is it to keep out the air? Would not a common frame answer the same purpose? A certain work says, after once placing them on the cuttings, "*wipe them out every morning.*" Is not this to remove damp; and would not wiping off the condensed moisture, on the inside of a cold frame, so as to prevent the moisture falling, answer a similar purpose? Or, might not air be admitted for a quarter-of-an-hour to dry it up? and, if so, what need of these expensive bell-glasses, especially when we have little enough to spend on such *matters?*" Now, some of these very matters puzzled my own brains more than twenty years ago, when there was no COTTAGE GARDENER to resolve a doubt, but when we were left to arrive at principles and theories through the stern teachings of facts. Our correspondent, with commendable zeal, tells us, that he "*likes to understand, and go through with everything he undertakes.*" There is no want in his inquiries, and that of others' that have reached me, on the same subject, but that of *definiteness*. The question of *cuttings* is too general. Different plants require different treatment. Ten to one but the plants our friend has in his eye require no such things as bell-glasses. But that is no conclusive argument against their use. I thought myself wondrous clever when I got cuttings to root in plenty, in my father's window, by adopting the simple plan of setting the pots on the floor during sunshine; and I deemed myself of still more importance when, in the shady borders of green-houses and forcing-houses, I got plants to root as if it were at my bidding. I did not find myself to be a perfect novice until I tried hard-wooded and difficult plants; and then, so crestfallen was I, that even such a simple thing as a hand-light, full of rooted pink pipings, gave me something like relief, because, then the first dim perceptions of the principles of propagating by cuttings passed through my mind.

However we gentlemen's gardeners may either blunder, or stick to old customs just because they are "*ancient ways,*" we may rest assured, that there is reason for the processes employed, so long as shrewd tradesmen, that must meet the competition of the market, adopt them. About twenty years ago, I noticed the finest sight of struck and striking hard-wooded cuttings I ever beheld; and, as not very long since I saw a similar plan successfully adopted, it may be profitable to detail it *here*. The house was a wide lean-to, with a pit in the middle and shelves all round. The pit was filled with tan and sand, so as to give out a

steady mild heat of about 70°. The plants, Heaths, Epacris, &c., had been slightly excited before the short cuttings were taken off; the pots had been more than three parts filled with drainage, then a little sandy-peat, covered with an inch of silver-sand, and well watered. When dry and firm, the cuttings were inserted and watered, when the tops were dry the pots were plunged for three parts of their depth in the pit, each covered firmly with a bell-glass, and then the sashes of the pit put on. You will observe, that here there were three thicknesses of glass: the roof of the house, the sash of the pit, and the bell-glass; and, notwithstanding the diffusion of light from passing these mediums, a slight shading was wanted in bright days. The following were the circumstances in which I found them. Some lights were close shut, and the bell-glasses beneath them close over the plants; beneath, other lights also close, many of the bell-glasses were raised a little on one side, because rooting was progressing; in others, farther advanced, the glasses were removed, but the sashes were close; while in others, the bell-glasses were not only removed, but there was an inch of air at the top of the light. In looking round me, I saw others standing with a great deal of air under hand-lights; and others, on open shelves, hardening off for potting. Now, I by no means say that such things could not be struck without all this attention and bell-glass-management; but I question if many other modes would be more *certain, expeditious, and economical*. With these general remarks, I proceed to make a few running notes on our correspondent's inquiries and deductions.

1. "*The great expense of bell-glasses to amateurs.*" I think they are the cheapest agents he can employ. A dozen of them, from four to six inches in diameter, may be got for about a crown, provided there is only one or two of the last size. Now, without saying anything of the expense of a frame, it is not likely it will be always devoted to propagating purposes; it most likely will have another crop during the season; but it is very probable, that now and then some cuttings of desirable things may come in his way; and then, if what we have said of air, &c., be true, the cuttings could not receive justice in the frame, and the main crop in it too. Now, in such a case, a bell-glass comes to our aid; for, if we even put the cuttings in the frame, by means of the bell-glass we can give the cuttings any degree of shade, of closeness or openness we require. Half-a-dozen, even, of such utensils would open up a large field for experiment. A good substitute would be to insert the cuttings in a small pot, and then set it inside a larger one, so that the tops of the cuttings are below its rim, and over that to place a square of glass that would cover the mouth of the pot. Turning the glass every day would prevent damping from condensed moisture dropping.

2. "*The use of the bell-glass.*" This is not merely to keep the cuttings from the exhausting effects of a free current of air, but also to prevent the evaporation of their juicy, by surrounding them with an atmosphere more or less saturated with moisture. Every leaf and green part of a cutting, previous to its being taken from its parent plant, performed perspiring, elaborating, and assimilating agencies. These were sustained by the reciprocal action going on between branches and roots. The first thing we do is to destroy that connection when we remove the cutting. Our next object should be to preserve the cutting as it is; to place it in circumstances in which it shall not be allowed to perspire more than it can absorb. Assimilation must, therefore, take place slowly, and thus we give light and air in proportion as the cuttings are forming a callus, or roots. Now, with bell-glasses, we could give every pot in a propagating frame its distinctive necessary treatment, which we cannot do without, because, in difficult cases, when we

either shade or give air to suit certain cuttings, we run the risk of injuring others.

3. "*Wiping bell-glasses every morning*, or wiping the inside of a cold-frame to prevent the dropping of condensed moisture." Now here, in the first place, in all tender and difficult cases, the exposure necessary on wiping a frame would be injurious. Besides, unless in cold nights, in autumn and spring, there would be little condensed moisture, which will always be in proportion to the moisture within, and the difference between the internal and external atmosphere. In all common soft-wooded plants, the leaving a little air on at night, or for a short time in the morning, will be sufficient. The wiping of bell-glasses did use to be a serious affair; but I have repeatedly shown how that trouble may be next to altogether abolished, by using *conical*, instead of *flat-headed*, glasses. In the latter case, the drops would fall on the cuttings; in the former, it would trickle down into the soil. By using double pots, placing the cuttings in the inner one, and the glass between the inner and outer, I have frequently struck tender things, that after being first watered, never had the glass moved until it was seen the cuttings were fairly growing, and that, too, when from first to last they had enjoyed a fair amount of sunshine. Not now to speak of the slow decomposition going on in such circumstances, it will at once be evident that the moisture raised by heat during the day, placed the cuttings in an atmosphere in which they were forced to absorb, as well as perspire. The cold of night condensed that moisture, and returned it to the soil, just ready to be brought up again the following day by a something like perpetual-motion process.

3rd. "*Allowing that bell-glasses are not essential for tender and hard-wooded plants, and a useful auxiliary for solitary instances of experiments and propagation; may they not be done without in the case of soft-wooded Greenhouse Plants, and those now generally employed for summer decoration, for baskets, and flower gardens?*" Yes, especially if propagation is confined to two periods—early in autumn, or in spring. In the first case, they should be kept cool. In the second case, they will rejoice in the excitement of a slight hotbed. In the one case, a result is obtained with a minimum of care, at the expense of a maximum of *time*. In the other, *time* is gained, but care and attention are increased. In both cases, I prefer diffused to shaded light. If placed two or three feet from the glass, little or no shading will be necessary; but these matters have already occupied attention.

4th. "*How many leaves should be left on cuttings?*" This must depend upon whether they are large or small, and the lesser or greater means at your disposal for preventing them exhausting the cutting by evaporation. I have had cuttings root quicker with all their leaves on than those partly mutilated; but then they were placed in circumstances that nurtured and stimulated the vital energies. A medium path is generally the safest. When the leaves are large, it is best to reduce them, and thus lessen the perspiring, evaporating surface; but no general rule can be given. In autumn it is advisable to cut to a joint, removing the leaves there, and either taking away or shortening a few above; but in spring, with the assistance of a slight hotbed, there are many things, such as Verbenas and Calceolarias, that we would consider it a waste of time to cut to a joint or remove a leaf; but the vital forces are in a different condition *then* from what they are in autumn.

5th. "*What temperature should we give cuttings?*" In autumn it should little exceed that in which the plant stood. In spring it will always be advisable to raise it a few degrees. This holds equally true of tender or stove plants. Hence the ease with which such strike generally in a hotbed under a bell-glass. When autumn-planted cuttings are long in rooting, they may

receive a stimulus by heat at their base when they have swelled or callused there.

6th. "*How should I water cuttings?*" This is a matter of great importance. Let the utensils and materials be well soaked and drained before the cuttings are inserted, and water so as to make firm and fill every cranny on the surface. After that, I prefer *dewing* the cuttings instead of soaking the soil. This is particularly necessary in autumn-struck cuttings, if you would save them from damping in winter. Such plants, even when rooted, and you give them all the air you can in dull foggy weather, will flag when a bright sunny day comes, even when they are moist enough at the roots, just because both leaves and roots have been enervated by the want of sunlight. In such cases, soaking away at the roots will only be the precursor of future cares, if not total disappointment. A slight *dewing* of the foliage, taking away the air, and, in extreme cases, a slight shading, are the proper remedies until the plants get used to the change.

Here I must stop, and my apology for the length of the article must be the fact, that the matters alluded to will, ere long, be engaging the practical attention of our readers.

R. FISH.

THE AURICULA.

(Continued from page 306.)

Winter Treatment.—Of all the seasons in the year, this is the most difficult to carry the Auricula ship safely through to the desired haven of spring. The difficulty consists in, or arises from, the nature of our variable climate. In its native Alps the air is keen and pure, and the perpetual covering of snow keeps them from growing, and at the same time shelters them from extreme frost and the cutting winds; so that when the warm sun of April melts the snow, and warms the air, they spring into life and bloom almost like magic. Just in proportion as we imitate this state of natural management or treatment will be our success; for although our Auriculas are, as my good friend Mr. Beaton would say, high bred, yet, constitutionally, they have the same character in regard to requiring a winter treatment, similar to their, perhaps, more hardy ancestors.

The season for this winter treatment commences towards the end of October. They should then be placed with a full exposure to the south. The best habitation for them is a cold brick-pit, placed upon an elevated stage of boards, with a flagged floor for it to stand upon, the floor sloping slightly to the front, and a convenience of giving air by means of sliding shutters in the wall, back and front, but as this is a rather expensive winter-dwelling, they may be kept very well in a common garden-frame, of a size proportionate to the collection. In this frame I should prefer boards to set the pots upon, resting upon bricks, so that the air can pass round, upon, and under the pots, as well as among the plants. A free circulation of air is very important at this dull, moist season of the year. Should none of these articles be conveniently had, they will do moderately well upon a bed of dry coal-ashes, so elevated as to bring the plants within six inches of the glass.

Having them safely into their winter quarters, the attention they require then is to give them plenty of air on all favourable occasions, and to shelter them from severe frost by securely covering them up while it lasts. Should the frost reach them, great care must be taken in thawing them. *The sun should never shine upon them whilst frozen.* Keep a mat thrown over the glass till the frost is slowly overcome, and then they may be exposed fully to it by drawing off the lights. Very little water will be required during winter, the less the better, providing the plants do not actually flag for the want of it.

By these attentions daily attended to, the plants will, towards the end of February, be beginning to grow, and will then require a close looking over. Every decayed or decaying leaf should be carefully removed without injuring the healthy ones or the stems, and diligent search made for the slugs and snails, and every one destroyed. Should worms be in the pots, they will show they are there by their casts on the surface of the earth. Generally, they may be got rid of by turning the ball of earth carefully out of the pot, and picking out the worms, which may be seen winding round the outside of the ball. Should they be inside, then, when the plant requires water, give it water impregnated with lime, this will effectually kill the worms. Water will, in February and March, be required more frequently and more liberally, to encourage the flower-stems and buds to appear strong and healthy; and thus I have been round the year, and then commences the top-dressing and attentions of the spring season.

Propagation: By Offsets.—I have already incidentally mentioned these, when describing the operation of potting, but I must enlarge a little here. No offset should be taken off until it has roots of its own. If very small, three or four offsets may be put round a pot close to the side, there to grow until they are strong enough to be put singly into small pots, but if moderately strong, they may be put into pots singly, in proportion to their size. In general, small 60's will be large enough, which are about three inches diameter. In these they remain for twelve months, and are then to be potted into the same size as the established plants. Blooming plants are usually grown in small 32's, which are 5½ inches across, inside measure. In these put the strongest year-old offsets, and they will bloom the next season.

By Seed.—This, to increase the chances of improved varieties, should be saved only from flowers of first-rate properties; and further, to increase with a certainty of success, such as are intended for seed should, when in bloom, be placed under a hand-light, far away from their inferiors. The seed-vessels are, in wet weather, very apt to turn mouldy and decay, and consequently destroy the seed also. The hand-light will prevent this also. Gather the seed as soon as it is ripe, and keep it in a dry room, hung up in a paper bag till the season arrives for sowing it. If you have the convenience of a greenhouse, February will be the best time, but if not, sow a month later in a cold frame; sow the seed in shallow pans, well drained, in light compost; press the compost evenly down, and then give a gentle watering; sow the seed upon it while moist, and then cover it about the eighth-of-an-inch, and cover the pan with a flat piece of glass. It will not require watering, because the moisture in the earth below will rise up and moisten the covering. Place the pan as near the glass as convenient, and watch the soil that it keeps moist. The seedlings will come up in about a month's time, and then remove the glass, or the plants will draw up weak. As soon as they can be handled with a pair of small sticks, transplant the seedlings into similar pans, similarly treated with respect to water, but without the glass covering; replace them on the shelf near the glass, and when the sun shines, shade them. It may be necessary to transplant them once more into fresh soil and fresh pans previously to potting them off into small 60's, and, indeed, is desirable to do so, if convenient, as it strengthens them greatly, and forwards their growth.

Pot them off into pots as soon as they have made four or five leaves, and place them under a cold frame, shaded daily until fresh roots are formed; then subject them to the summer treatment, and pot the strongest into blooming-pots in September. These will bloom the following season.

T. APPLEBY.

(To be continued.)

CONIFERÆ.

(Continued from page 286.)

PINUS.—This genus contains the greatest number of species of the whole tribe of Coniferæ. It is distributed through almost every clime of the world. The common Scotch Fir (*Pinus sylvestris*) is found growing to almost the utmost limit of vegetation on the cold mountains of Norway and Sweden, whilst other species inhabit the mountains of Mexico, in the warmest latitudes. This universal distribution of these trees, sheltering man and beast both from cold and heat, is another great proof of the benevolence of the Creator of all things towards His creatures, enabling them to bear and exist in climates that would otherwise be uninhabitable. From the various species of this large division of Coniferæ, mankind extract, besides timber, various substances of great use in the arts and manufactures of every-day life. Oil of turpentine, common and Burgundy pitch, Hungarian balsam, Bourdeaux turpentine, are obtained from this genus and administer to the wants of man; and then he makes use of the wood for building his dwellings and for fuel, for which latter purpose it is admirably fitted, on account of the abundance of oily matters it contains.

The trees belonging to the genus are found in various altitudes, some growing on lofty elevations, whilst others inhabit valleys almost down to the sea-shore. The genus is distinguished by the great length of the leaves, which grow in sheaths or bundles; by the cones, which are oval, and have their carpels, or scales, thickened at the top, so as to hide the bracts; and their carpels are persistent, remaining attached to the axil of the cone for years after the seeds have been shed. The cones, too, in contradistinction to the cones of the Spruce tribe, are generally erect, that is, the small end points upwards. By these marks the Pines may be easily distinguished from other genera.

It is somewhat remarkable that there are, in this genus, a certain number of species that have two leaves only in each sheath, others three, and others five in each bundle. And as this is not a chance affair, but is regular and constant, I shall arrange the species in my enumeration of them in three divisions:—1st. Such as have two leaves in a sheath. 2nd. Three. And 3rd. Such as have five leaves in a bundle or sheath.

DIVISION 1ST—LEAVES GENERALLY TWO IN A SHEATH.

PINUS AUSTRIACA (Austrian Pine).—A very hardy, robust-growing tree. It has been found to bear the sea breeze better than almost any other evergreen tree; hence it is important to the owners of land so situated.

PINUS BANKSIANA (Sir Joseph Banks's Pine).—A native of the cold regions of Hudson's Bay; a low-growing tree of considerable beauty. The natives of these inhospitable regions cover their huts with its branches, which, when covered with snow, look like so many enormous snowballs, and are, when heated with its logs of timber, warm and comfortable. It was named by Mr. Lambert in honour of that scientific and enterprising botanist, Sir Joseph Banks.

PINUS BRUTIA (Calabrian Pine).—Native of the Calabrian mountains. It has a synonyme, *P. conglomerata*, from the clusters of remarkably handsome long cones it produces. Perfectly hardy, and produces excellent timber.

PINUS FISCHERI (Dr. Fischer's Pine).—So named by Mr. Booth, of Hamburg, a celebrated nurseryman there. Very little is known of this species.

PINUS FREMONTIANA (Captain Fremont's Pine).—Named in honour of that hardy, enterprising, and persevering explorer of the regions of which it is a native, namely, the mountains of Sierra Nevada, in California. It is a very remarkable tree, producing its leaves some-

times three in a sheath, and sometimes only one. The latter peculiarity induced Dr. Torrey, and even Captain Fremont, to name it *P. monophylla*, or the One-leaved Pine, which, had that circumstance been constant, would have been very appropriate. The seeds are large and eatable, so pleasant and wholesome that they form a large portion of food of the Indians who reside where it grows. The cones are produced plentifully, and therefore it would be a desirable addition to our fruit-bearing trees in this country. The Indians call it the Nut Pine, and these (the nuts) are said to be of a pleasant almond-like flavour. As yet it is rather scarce, but will, no doubt, soon be abundant, as it is hardy enough to produce its delicious nuts in this country. It is a low-growing tree, averaging about twenty feet high.

PINUS HALEPENSIS (Aleppo Pine).—As this is a native of Syria, it is not quite hardy in the northern parts of the island, but bears our winters well in the southern counties. It is, perhaps, the most elegant of all Pines, and wherever it will exist should be cultivated. It is even worthy of a place in a conservatory. It grows rapidly, and is a somewhat low-spreading tree.

PINUS INOPS (Poor or New Jersey Pine).—Often mistaken for *P. mitis*, but its leaves are shorter, and it is not so handsome in habit.

T. APPELBY.

(To be continued.)

MAKING ASPARAGUS BEDS.

THERE are, doubtless, many gardens where the important work connected with the raising of permanent crops will have been retarded by the unusual wet season we have had; and, in some instances, we fear the press of other duties in the spring months will prevent many things being done which were contemplated early in autumn; this, of course, relates only to such jobs as can, without any great sacrifice, be put off until another year. But there are some operations which can be as well done in spring as autumn, and amongst that number is the formation of Asparagus beds.

In many gardens, situated in districts uncongenial to healthy, vigorous vegetables, the production of this one in good condition is anything but an easy matter, delighting as it does in the deep, rich, alluvial soils found in the valleys flanking many of our rivers, and similar places where the accumulated richness of the adjoining heights had, through countless ages, poured their treasures into the flat below, has certainly given the locality a character and combination which we in vain may look for in any mechanically-contrived soil, which we, by mixing opposite substances, may substitute for it. But it becomes the thinking cultivator to consider what can be done to render them as productive as possible; and we all know how much has been done under such adverse circumstances, that we may yet hope to see the difficulties attending the growth of really good Asparagus overcome, when our knowledge of the laws relating to soils and their component parts shall enable us to present each individual with its own particular mixture. Now this part of our craft has certainly not been very successful yet in the culture of Asparagus, as I have seen beds that had been trenched a yard deep, and brushwood, stones, and other drainage, buried in the bottom by waggon loads, and all to no purpose. The Asparagus certainly did not perish wholesale, but it did so piecemeal, after producing for a very few years some few heads of very indifferent Asparagus. That there was something radically wrong in the matter, was evident to every one; but that it was not owing to the want of manure and other enriching substances accorded to the beds with a liberal hand; but somehow, the mere adding of cart-load after cart-load of good useful dung, both fresh and

decomposed, is still unable to afford this vegetable that description of food it is by nature adapted to assimilate, and consequently valuable matter is needlessly thrown away. Now, though it may appear feasible that a plant, like the Asparagus, producing such a quantity of fresh roots every year, and sending them to seek food every year to the same place their predecessors did the year before, must necessarily, sooner or later, exhaust that spot of those ingredients most suited to its growth; but somehow, the requirements of the plant is such, that merely adding large quantities of manure on the top of the beds every autumn, for the rains to wash the juices down to the roots, is not the way to afford the latter the food most in accordance with its wants. Much of it is necessarily washed below the action of the roots, if the soil be at all of that porous kind the Asparagus delights in; if it be not, the result will be equally unsuccessful; because a heavy, tenacious soil, that is retentive of water, will never produce this vegetable in good condition. Now, though we do not deny but that dung so placed on old asparagus beds, and its juices, by the rains of winter, allowed to filter through the stratum of soil forming the beds, may do some good, yet we cannot regard it as the most profitable way of supplying food to the plant, because the latter does not require it at the time it is offered; consequently, it is easy to infer that much of it must necessarily be lost. As the action of the roots of the plant and that of its top are reciprocal, it follows, that when food is administered, it ought to be at such times as these important agents of the plant's welfare may benefit themselves to the full extent of the quantity given, which, of course, every one knows is in summer; therefore, to those who wish to excel in the production of this vegetable, we say, supply it liberally with liquid-manure during the summer months, and now and then add a little salt to it; by this means the roots will receive all the benefit of the substance applied at the time they require it most; but, as the present and forthcoming season is the one suited to the formation of new beds, a few words on the subject will, perhaps, not be out of place.

In those gardens where the soil consists of only a thin stratum resting on an impervious clay, or hungry sand or gravel, where vegetation is simply made to flourish by excessive applications of dung, &c., on such soils some extensive operation must take place if good Asparagus be required, because the depth of good staple soil it requires demands that as one of the primary conditions to insure success; but the treatment of ground resting on retentive clay must be different from that on porous matter; the latter, parting quickly with superabundant moisture, must be removed to make way for a stiffer substance. The practice is this: a plot of ground having been fixed on for the intended beds, first remove all the surface-soil that is good, then the inferior portion, to such a depth as will allow a cavity of not less than two feet good, or, if two-and-a-half, so much the better. The bottom of this excavation we expect to be sand or gravel, porous to an undue degree. Now, on this thirsty substance, I would place clay, or retentive loam, to the depth of three inches, which would arrest the descent of the moisture, while, at the same time, the demands for water below would suck sufficient from it to prevent its ever becoming soddened by too much moisture. The materials for the bed may then be put in at once, taking care to have a sufficient quantity of a stiffish kind of soil in the compost, because the imported portion will eventually assume the character of that to which it is annexed; it is better, therefore, to supply it with those ingredients which are most slow in effecting that change, while a sufficiency of dung and other things ought likewise to be supplied, so as to entice a vigorous growth to the plants when first planted there. In the compost used, it would be better for all the ingredients to be mixed

some time before being put in; but this is not absolutely necessary, because some little time elapses before the roots of the plant reach that part of the bed which has least access to the air, during which time it will have amalgamated itself with the objects surrounding it. We may observe, that amongst the soils to which Asparagus has a great aversion, is the one in which iron predominates; this soil, which shews itself so conspicuously by little pools of water having a sort of skin on their top, and the bottom, after it has receded, will appear red and rusty—this soil is highly injurious to the Asparagus, and when this predominates in a neighbourhood, we have little hopes of success there, except by extraordinary means. Lime and chalk are less objectionable, although they are not the proper food for this plant either. The rich alluvial soils of the vale of the Thames is more the debris of other things, and we do not know any place where such good Asparagus is grown. But a fair share of success will attend the cultivator who takes the trouble, as above, in dry, hungry soils. The damp thin ones, of a retentive character, require different treatment; they want additional soil, without excavation. In other words, whatever is added thereto must be done so as to raise the plot above the general level of the adjoining ground; for we have no hesitation in saying, that to excavate the subsoil, which we take to be clay, and fill in some six inches or more of loose stones and other drainage, and then fill in the top earth, is worse than useless, unless there be an efficient outlet for all water collected in the stratum below, which is not always the case; besides which, ground of a decidedly stiff nature has a tendency to convert other soils that may be as far from the surface as itself into a like stiff character. These, and other reasons, lead us to prefer making new Asparagus beds on ridges elevated above the natural ground, in order that the stagnant moisture may be so far avoided as not to do much harm; it is likewise advisable to use porous substances in this mixture with more freedom than in the preparation of beds on the light, open soils first adverted to, because the adhesive nature of everything surrounding it will render that more necessary.

As it is important that beds intended for permanent use hereafter should be well made, and not denied anything likely to ensure their well-being, yet it is equally necessary that all operations should be done when the ground is tolerably dry; it is, therefore, as well to leave it undone until spring, when it may be performed without that plunging and treading which is disastrous to soils at this wet season of the year. The planting may be then done likewise, if one-year-old plants be preferred; but some sow at once where they are to remain; and some sow early in spring, on some good border, and plant out in July or so, when the seedlings will move without loss. Whichever way be adopted, it is better to avoid that heavy crop of vegetables which many, in their anxiety, seem determined to have on ground they have treated so liberally to dung, forgetting, at the same time, the injury it does to the legitimate occupant of the beds. This, however, is more a matter for after-consideration; but the material for the maker of the beds may be prepared in the meantime, so that when the fitting time does come everything may be ready. The plan of sowing or planting differs much with many cultivators; but, usually, rows two feet apart are thought best; and two or three years afterwards every third one taken away, leaving a space for an alley, which is also not without its uses, for summer vegetables may be cultivated there when shade and moisture may be denied them elsewhere. There are many other modes, and all tending to the same end.

J. ROBSON.

THE GARDEN PILFERER.

By the Authoress of "My Flowers," &c.

THERE may be, among my cottage readers, some who are, or some who *know* such as are, characters very like one I am going to remark upon; and, as I doubt not, they are little considering the end to which they are travelling, I would earnestly pray their attention to the conduct and condition of an unhappy woman, whose name I shall call Betsey.

She bore for many years, and with some persons, the reputation of being a kind daughter to an aged, bed-ridden mother; but her neighbours *could* have told a very different tale if they had chosen. She had been always used to outdoor work, and when she was middle-aged she became a regular weeder, and useful garden-woman, in the employment of a gentleman in the neighbourhood. She was so active and handy in her work that she became a great favourite, and was allowed to pick up snap-wood, and often received her apronful of vegetables, with other little perquisites, such as favoured servants receive from their employers. Her poor old mother died, and Betsey, having only herself to provide for, got on very well. Her wood-house began to be so full of faggots that they poked their way out at every crevice; only, as she was out all day, and only needed a fire at night, people could not put their finger upon anything against her.

Fruit and vegetables have no legs or feet, it is well known; but those in the garden of Betsey's master disappeared in a marvellous manner. Trees stripped themselves of gooseberries, apples, cherries, &c., as if by fairy hands; no one could tell how they went, or where they were gone. Betsey looked extremely distressed and innocent, but privately gave her master to understand, that "the young gentlemen were always in the garden after the fruit when his back was turned," and no doubt they were the offenders. It is very difficult for boys to clear themselves of charges such as these; but other members of the family, who knew them to be false, began to suspect the person who made them. The other persons employed about the house had worked there for years, and were well known; but there was a something about Betsey, both in look and manner, that was not open and honest, and, altogether, she became an object of doubt to all but her unsuspecting master.

It was a very long time, some years, during which all this was going on; but at last a rumour reached the family, that was closely enquired into; and it was found that Betsey had all this time been secretly selling fruit and vegetables in the village, assuring her neighbours that her master had entrusted them to her to sell for his own profit, and that if she did not get the money for them, and take it down regularly to him, that she should lose her place. Here was a fact, and a foundation to act upon. The suspicious and doubtful accusations that had had no effect upon Betsey's master hitherto were now proved to have been no unkind and groundless charges; she *was* the thief, and the "young gentlemen" were innocent. Of course, she was immediately discharged, and then many things came to light which had been all dark and mysterious; and the villagers were very glad to find that justice had overtaken the guilty at last.

Some time after this, Betsey went to work for another family, at a little distance; but she was there a very short time, and was dismissed for clearly-proved dishonesty, so that no doubt remained of her want of character on this point. Very strange tales were told of her, too, with regard to money, that she had lent money to the man from whom she rented her house, and that "the writings" were in her hand as a security. Events have proved that much of this must be true; and how was a poor worker in the fields to amass money?

In the course of time Betsey's health failed, and she was unable to work. None of the neighbours liked her, or even thought well of her. Her landlord was constantly at her cottage, and was heard to say she should never want, and no one cared therefore to go near her. They did not like her ways or her doings.

When her old master was borne to his last resting place by the "cottage gardeners" who had for the longest period rented his allotments, Betsey crawled out of her house to see the procession pass. She said he had been her only friend; and so, indeed, he had, but she had abused

his kindness, robbed and deceived him, and tried to injure his character, too, for her own ends.

Since then she has been greatly afflicted, somehow or other, in her limbs; it was painful to see her creeping down the street upon crutches, scarcely able to move one foot before the other, and evidently in great pain. The expression of her face was always bad, but it seemed to grow worse; and as she came and went on her weary way to church, or the shop, no friend looked pleasantly at her, or used to ask her how she was. We have the highest warrant for knowing, that "Godliness hath the promise of the life that now is, as well as of that which is to come." Poor Betsey's "life" was not one of *promise*; it seemed to be one of desolation and pain, as well as of want of reputation, and altogether she was a melancholy spectacle as she laboured onwards.

One day, about a month ago, we ourselves happened to see her creeping onwards in her long cloak, bent down as usual, and "hirpling," as the Scotch say, with her customary difficulty. We had, I believe, only just turned out of the village, when she was seen to reel and fall, and lie helplessly on the ground. The neighbours raised her with some effort, and carried her into her cottage, where a bed was made on the kitchen floor, and she was laid in it. There she has remained till this hour, and there she will remain until she stands before the Great White Throne.

For some days she was scarcely sensible, but her senses have returned, so that she can at times talk and listen; but, as a neighbour said, "her hands and her tongue are all of her that can move;" she is otherwise powerless, and lies like a log upon the bed, in the little narrow comfortless kitchen where she had lived so long, a melancholy sight. Two of her neighbours, who are blessed with "bowels of mercy," take it by turns to sit up with her. They say she is thankful and quiet, but dreadful to move, from her cries and helplessness. The state of her mind is far worse than her body—hard, unconcerned, and satisfied with herself! Half wandering at times, yet contented because the depths within have never been broken up, she lies a spectacle *at present* to men and angels. "Oh that men were wise, that they understood this, that they would consider their latter end!" To those who speak to her of her spiritual state, she returns hard, indifferent answers; but while life is prolonged, there is yet hope that the day of grace may not be past.

I would earnestly entreat my humble readers to ponder this in their hearts. I would suggest to those of a higher class to put this paper into the hands of such as are employed in their gardens and farms, because it may, by God's blessing, touch some heart going on still in its wickedness, and perhaps in the very way that Betsey went. She lived without raising one kindly feeling; no one liked her, or dared to go near her, because of the language she used. Her house was the abode of sin. She *robbed and injured a trusting and good master* on earth, and became greatly, wonderfully afflicted in her body. Everyone shunned and thought ill of her. She lived without God in the world, and has been struck down before the eyes of man, and laid helplessly aside. She is *really* the most desolate object possible, because, though kind offices are performed for her, she has *no friend*—no one to bid God bless her. Sin will always find us out.

Oh! let all who are unfaithful to God and man remember that punishment *must* come, and that none can be so dreadful, so horrible, as calmness and indifference on the bed of death! Better to suffer agonies of terror than cold self-contentedness! "Ephraim is joined to idols: let him alone!" Oh! what tongue can tell what it is to be *let alone* of God! No working, no awakening of the Spirit; but to be left even while in the body, in the cold hopeless sleep of death!

Let my *humble* readers "awake and arise from the dead," now while there is time for repentance, "and Christ shall give them light." If they could see Betsey as she lies now, they would feel that but "one thing is needful," and seek grace to choose "that good part that shall not be taken from them."

ALLOTMENT FARMING—FEBRUARY.

SURELY it is high time that this month changed its wonted habit. A "fill dyke" month is not exactly the thing that the cultivators of the soil require; and we have had a tolerable share of moisture already. Surely the oldest man living cannot call to mind such an extraordinary winter, if such it may be called, as we have partly passed.

Here we are, then (January 16th), after undergoing nearly a quarter-of-a-year of dullness, almost incessant rain, and a total absence of frost, or, at least, any worthy the name, in November, December, or January. This state of affairs has thrown cultural transactions into such a puzzling position, that men grown grey in the service scarcely know how to proceed. However, one thing is certain—surplus waters must be got rid of, soils must be exposed to the air, and this in as little time as possible. The spring, with its cropping, is pressing hard upon us, and "he gives twice, who gives quickly," may be borne in mind.

And first, *drainage*—who has not better appreciated its importance than ever he did before? The question of its propriety remains precisely the same, but the recent excessive period had been a good illustration of the singular utility of drainage on stagnant or adhesive soils. When a writer advises sharp attention to drainage, and the amelioration of the staple soil, during a fine, dry, and mellow period, people are apt to think that he is straining a point. But if he be a "true prophet," the recurrence of damaging periods will plainly show that, although seasons may vary, may have "a run," may prove very capricious for a lengthened time—yet, that cultural principles, based on averages, and backed by both science and practice, will at last have to be resorted to, if *progress* be the word.

And now what shall we do? This is the main question under existing circumstances. To those who have omitted putting our drainage advice into practice in due time, we say, open temporary water-courses wherever possible, if needed. If only for a few weeks, try and coax all water away, in order that the air may enter the pores of the soil; for even the poorest of our allotment friends must know that two bodies cannot occupy the same space at once. If any doubt this, let him fill a gallon vessel with water, and then pour in a gallon of any soil, or, indeed, any substance, and he will find the heaviest body speedily displace the lighter. But our old-fashioned country-bred men, who have never been to Oxford, will scarcely believe that water is a body, or that air is a thing demanding space. But so it is, and our good friend, Mr. Fish, could tell a pretty tale, in his philosophising way, about the old geranium in the cottage window, and would, doubtless, show how it was that when this old pet became very dry, and water was applied, the soil continued to throw up bubbles, and made a gurgling sound for several minutes. Before the air, which is the great improver, can enter soils to benefit them, depend on it the water must be removed; and it is not a question of air alone, the returning warmth of spring is by such means conducted to the soil—yea, to the very subsoil.

And now the time is at hand in which *digging* or *trenching* must be performed; hitherto, doubtless, delayed by the extraordinary winter. Everybody knows, full well, that there are periods set for the getting in of certain crops, and that it is well to come as near to those periods as possible. So nice a point was this esteemed in our younger days, that the gardener about the great Metropolis who did not sow his cauliflowers on the 24th of August, and his early peas about Lord-Mayor's day, was not considered an orthodox character. It so turns out, however, that under extraordinary circumstances we may with propriety depart from such rules; and really the character of the past season would seem to warrant such a procedure.

It does appear, therefore, that the coming spring will be late as to operative measures, and unless a singularly dry period occurs, when we have little right to expect it, both sowing and planting will of necessity prove protracted matters. This must put our friends on their guard, and we add a maxim well known to practical men—"better sow late than sow badly." And now for the digging and manuring necessary for the various crops; the time is at hand that such *must* be carried out. Still, let us add, rather postpone the operation than dig ground in a wet state. In

this spring, more than in many, will it be an act of fairness to allow allotment holders who are but servants, the privilege of a day or two to their own plots, for after hours may not serve to accomplish what ought to be done for some weeks yet. About manures, we must again repeat, that in the present state of matters, mixtures, or composts, if you will, are best for general purposes, and in all such mixtures we would fain have the ordinary dung of the midden, previously turned and reduced, play a conspicuous part.

It is, indeed, impossible to overrate the importance of the turning and breaking to pieces *manure-heaps*; dung will not only go much further, but, by mixing more thoroughly with the soil, will the more benefit the crops. Besides, if guano and soot are added, a practice advisable, even though it be in a small degree, it may be made to mix with the whole mass. We have the concurrent testimony of farmers with our own experience to show that mixtures of manurial matters both go further and prove more beneficial to the majority of our crops. Where old gardens have been long under crops, and contain much dark matter or humus, lime will be found useful, if at hand.

In consequence of the untoward season, digging and trenching will be in arrears with many, and it will be highly advisable to ridge all adhesive soils, if only for two or three weeks, taking care to wait until such ridges are very dry before levelling them down, and taking extra care in the latter process.

Of course, the allotment holder has his course of cropping laid down, and in order that there be no mistakes, let him cut a few sticks, and having flattened one end to write on, get a little thick white paint, and having smeared a little on the shaven part, write on it, whilst *wet*, with a lead pencil, the digging, manuring, the crop and its successor, or mixed croppings, if such it be; he will thus know at a glance, and be reminded of sowing such as the cabbage-worts for mixing, or for succession.

What *Seeds* are requisite should be procured immediately, and kept in a dry place, and if any old seeds of last year remain they had better be tested. They may be soaked six hours in tepid water, and a given number, say twenty-four, sown in a pot, and placed in a warm room; by counting what sprout, it will be known what reliance can be placed on them.

About the middle of the month the hoe should be run through those *Cabbages* which were planted in autumn, seeking a dry day for the purpose, and hoeing deep. On the heels of this the plot should be looked over, and any blanks made good from the store beds, which every good cultivator provides in autumn. Those remaining in store must be got out at favourable opportunities before the end of March. Many will probably be wanted for mixed cropping. For instance, the mangold or swede ground being dug and levelled down in due time, a double row of cabbages may be put down each centre, unless it is required for early potatoes. We have a plot of land from which we have taken crops of mangold for eighteen years; this is manured entirely with our pig and cow-dung, and the sweepings of the chimneys. From this we take a fine crop annually of the Ash-leaved kidney potatoes. One-half is swedes, the other half mangold, and these change about annually. The kidneys are planted in double drills in February, in every centre between where the mangold and swedes will be, and when the kidneys are removed in July, their place is occupied with swedes from a seed-bed.

Onions may be sown in the last week, if the soil is ready, but such is unlikely this season. Let the ground be very deeply dug for this crop; it should, if possible, be wrought two feet; they will, indeed, descend a yard. If manure is requisite, it may go between the two spits, and if the onions come weakly for a while, some guano-water might be applied.

Parsnips may be sowed about the same time as the onions, trenching deep, and manuring pretty well. A bed of the *Early-horn Carrots* should, by all means, be sown in the middle of the month, in a warm spot, the bed much elevated. These must be protected, like radishes, and care taken, when up, that the slugs or snails do not run off with them. We must again recommend some dressing to be kept ready in a dry corner; the following is very useful—

one bushel of new saw dust, half-a-bushel of very fine cinder-ashes, the dust blown out, and one peck of fresh slaked lime, all well blended, or it would be well to slack the lime as wanted. We use this all the spring and seldom lose a crop.

The beginning of February is an excellent time for sowing full crops of *Peas* and *Broad Beans* or Longpods; no pea is better for the cottager than the *Green Imperial* or the old *Prussian*. The Imperial is sooner off the ground than others, and consequently makes way for autumn cropping; A little early *Cabbage* may be sown at the end, and *Lettuces* with *Radishes*. The *Ady's Cos* is the best; it needs no tying. If any August-sown lettuces have been provided, they must be planted out, if in store, in the end of the month, on rich soil.

Potatoes: our practice is to plant early kinds at the end of February, and in the early part of March. If, however, the seed has been preserved as it ought to be, the middle of March will do well. As for the Ash-leaved kidney, we never plant until the end of March; this kind forms an exception to the rest. We make a point of sprouting them before planting. The best plan we know is to spread three inches deep of sawdust on a warm floor in the end of January, and to stick the Ash-leaf kidneys on their end in this material. Here they will produce stout buds of about an inch in length by the end of March, and must be removed so that not a sprout is damaged. We have had much practice with this potato, and know the practice to be sound, because always successful.

Rhubarb should be covered immediately, if not done; old chimney-pots, with a whisp of hay in them, answer well, and these, with warm dung around them, bring it very early. The breeding-time of *mice* is at hand; care must be taken to destroy them, or woe to the peas.

And now, until we take the pen again, let us advise our small gardeners to be on the alert whilst the spring is young, and by extra efforts, and increased diligence, to endeavour to make up for the untoward season we have passed.—R. ERRINGTON.

THE APIARIAN'S CALENDAR.—FEBRUARY.

By J. H. Payne, Esq., Author of "The Bee-Keeper's Guide," &c.

EXAMINATION.—It will be necessary to examine every stock very carefully early in the month, both in regard to its store of food, and to the state of the hive with respect to dampness; for, unless the protection has been very complete, the late continued and driving rains will be found very injurious in their effects.

DAMPNESS.—Wherever dampness and mouldiness are discovered, it will be well to supply a fresh floor-board; and in the middle of a mild and drying day to raise the hives all round upon little blocks of about half-an-inch for an hour or two.

FEEDING.—Feeding, I fear, will be found more necessary this spring than in any one that has of late years preceded it, for, from the extreme mildness of the winter, the bees have been in almost constant activity, and, consequently, consuming a much larger portion of food than when in their usual quiescent state; feeding should be effected at the top of the hive, if possible, but, if with barley-sugar, it is not so imperative as when liquid food is used.

ALARM.—Mr. Newman has already sounded an alarm in THE COTTAGE GARDENER of the 6th of January. I hope his "caution" has been attended to by its readers who are bee-keepers, for never before, in my remembrance, has there been so much cause for it.

POULTRY SHOWS.

TRURO.—The extreme south-western district of England seems to have entered with great ardour on the work of improvement as regards poultry, for on Monday, the 3rd inst., there was an exhibition at Truro, and on the 10th and 11th the Cornwall Society held its second meeting at Penzance.

At Truro, we found ourselves in one wing of the market-

house, a building well adapted for the purpose; and in the arrangement for the accommodation of the birds great judgment had been manifested. At two o'clock, the awards having been completed, the public were admitted, and till nine that evening, and four, p.m., the following day, the room continued well filled.

Spanish, as usual, commenced the list, when pen No. 2 shone conspicuous; and if in figure, head, and general character, they proclaimed their close relationship to the well-known stock of the most successful breeder of their race, they did full justice, by their condition and feather, to the management of their present owner, Mr. W. J. Lawrence, of Penzance. No second prize was given to the older birds, but the chickens of Mr. Pennington, and Mr. T. N. Miller, received 1st and 2nd prizes.

Dorkings, as a class, stood in great need of the improvement that Poultry Societies are now effecting; another year, and we shall hope to get rid of much that we could not but object to. Weight, no less than plumage, was deficient; and colour and figure were strangely contrasted in the same pen. But the *grey* birds of Mr. George Williams, and the *white*, belonging to Mr. Augustus Smith, deserved better neighbours; these were, certainly, fair specimens of their respective classes.

Among the *Shanghaes*, Mr. R. H. Bowman's white birds, both old and young, were the objects of general attention; and closely were their pens surrounded. Good management had placed them here without a soiled feather; and when we add, that in point of shape, as well as size, they would lose by no comparison, it will not be surprising that such unanimous admiration should have been lavished on them. Mr. W. J. Lawrence's and Mr. Blea's birds were both deservedly distinguished by the judge. Mr. Gittus was highly commended; and in chickens, he took a second prize.

Breeders of this class would do well to consider how they may avoid that tendency to legginess that has shown itself at many of our late exhibitions, especially in the cockerels—a fault, we think, most diligently to be guarded against. Let them also remember, that size may be gained at the expense of symmetry, and that mere weight goes but for little.

Malays, *Game-fowl*, and *Hamburghs*, follow on the list. Of the two former, we had looked for better birds, especially, when we remembered the beautiful pair of *White Game* that were brought here last year. The *Hamburghs* were not numerous, but included some nice specimens, the property of Mr. Miller, of Truro.

Black Polands could not be commended; but Mr. Hawke, of Truro, showed a good pen of *golden*, and the *silver* of Mr. Miller and Mr. Pennington fully bore out the justice of their awards. Mr. Bowman's *white* Polands, which had been victorious at Birmingham, had equal honours here.

In class 27, for any other distinct breed, a number of *Minorcas* and *Anconas* were shown. Now these birds, betraying such evident traces of a Spanish origin, however impure and degenerate, have no title to be thus distinguished; and another year will not, we hope, again witness their competition for prizes which should always be reserved for fowls of unquestioned purity of blood.

Of *Gold-laced Bantams*, Mr. George Williams had good specimens; and the *Almond Tumblers*, belonging to the same gentleman, were excellent. Some *Black Carriers*, *Jacobins*, *Fantails*, and *White Trumpeters*, were specially noted amongst the *Pigeons*. Mr. G. Williams's *Geese* and *Turkies* deserved and obtained the highest approbation. *Ducks* will be better another year; and *Pea-fowl*, it should be remembered, are shown to great disadvantage at the present season, which must account for Mr. Hawkins's birds in this class not realising the higher step; but judges must decide on what birds *are*, not on what they *may be*.

Uniformity in the pens, no less with respect to colour than form and general appearance, will, doubtless, another year be more generally studied than a first exhibition can give time for. Truro, however, may well congratulate herself on this favourable commencement of her Poultry Society; and if, as is confidently expected, arrangements can be made for the union of this association with the Cornwall Society of Penzance, the objects of both bodies will be far more effectually carried out, and their practical utility more permanently established. There is every reason to believe that such will be the result, from the general conviction of

all those who are most interested and best informed on poultry matters.

The *Judges* were Captain Mansell and the Rev. W. W. Wingfield, of Gulval; and we should think that if anything could reconcile to their task those who may fill that responsible office, it would be the good-humoured assent to their awards, which even the unsuccessful candidates on this occasion so readily bestowed.

THE CORNWALL POULTRY SOCIETY'S PENZANCE EXHIBITION.—Evidence is daily accumulating as to the practical utility of the Poultry Societies and exhibitions whose transactions have lately occupied so prominent a position in the columns of THE COTTAGE GARDENER. Those who first bestirred themselves in this branch of agricultural economy made up their minds to encounter difficulties, not merely from the indifference, but, in many cases, from the positive opposition of many, who expressed themselves even in terms of indignation at the attempt to suggest a better system of management for that class of live-stock whose well-being had hitherto been so little regarded. And well it was that they were so prepared; for remarks have not been always limited to the good-humoured joke on the trivial character of such pursuits. The readiest and most effectual answer to our opponents on this point, has been the continuous development of the various points of excellence in those classes which are specially distinguished for culinary honours. The *Dorkings*, no less than those other varieties that occupy different degrees of merit in popular estimation, *Geese*, *Ducks*, and *Turkeys*, illustrate our meaning, when we now compare them with such specimens as might be taken as the fair average of some few years since.

Paris, we know, was usually had recourse to for furnishing those choicer specimens of dead poultry for which it had obtained so great a repute; but a few weeks since, we found, to our surprise, that Brighton was the source from which the table of an inhabitant of the French metropolis, confessedly most competent to decide, was regularly supplied; and that even the Parisian poultrymen could not but acknowledge the justice of the award.

At two o'clock on the afternoon of Monday, the 10th inst., the doors of the Penzance Corn Market were opened to the public, whose presence on that, and the following day, fully bore out the expectation of general support, that had induced so convenient an arrangement for both spectators and the objects of their attention.

The 1st prize in *Spanish* corresponded with the Truro award of last week, and, in all the characteristics of that striking variety, proved the judgment of their owner, Mr. Lawrence, of Penzance, in the selection of his stock from Captain Hornby. His pen of chickens has unfortunately suffered by the mutilation of the cockerel's comb, which, with other evident tokens of a recent conflict, told against them; but an accident of this kind we are all liable to; and, provided 300 miles in mid-winter be not an insurmountable obstacle, Mr. Lawrence must uphold the credit of Cornwall at the Birmingham meeting of the present year.

Of *Grey Dorkings* we had a good lot, especially those belonging to George Williams, of Trevice, near Truro, and E. Rodd, Esq., of Penzance; and closely riveted on these pens did we notice the attention of many of our agricultural neighbours, and their consequent applications as to where good specimens might be attainable. In the *White* birds, there was, perhaps, a want of substance; but those of Augustus Smith, Esq., the Lord Proprietor of the Scilly Islands, had many good points; but on noticing a deficient bird, which spoilt the pen, we found that those intended to be shown had been claimed at Truro, and, consequently, no time remained for a more careful selection. Mr. Williams took a second prize; and a bird of Mr. Hicks would have done more with better companions.

The *Shanghaes* were deservedly commended by the Judge, Mr. Andrews, of Dorchester; and commendations from such an authority may well be prized. Here, again, was Mr. Lawrence successful, taking first prizes with his buff birds, in both the old and chicken classes. Equal second prizes were awarded to Mr. Bowman and the Rev. W. W. Wingfield, of Gulval; while the weighty birds belonging to Mr. Blee were honoured by the double rosette that indicated high commendation. It would be a bold assertion to speak of the existence of better white *Shanghaes* than Mr. Bow-

man's—assuredly, in condition they could not be surpassed—and in symmetry, no less than weight, their presence must have relieved the Judge's mind from doubt of any kind. A remarkably fine pen was shown by Mr. Gittus, but their unfeathered legs told against them; had it been otherwise, their position would probably have been different. Mr. Rodd had a singularly compact and weighty dark partridge hen.

In chickens, Mr. Lawrence and Mr. Bowman took first prizes for the buff and white respectively; no second prize was offered in this class, but "highly commended" was affixed on Mr. Wingfield's pen, bred from his birds that took the second prize in the older class. Mr. Gittus was here again commended for pen 55.

Malays we may say little of; nor need we dwell on *Game fowl*; among which, however, Mr. Rodd had a good grey cock, but the hens with him did not match.

Mr. Grenfell's *Silver-pencilled* and *Spangled Hamburgs* carried off a succession of second prizes—but better things await him another year, if in the *Spangled* class he obtains rather lighter colours, and more distinct markings, both in that as well as in the *Pencilled*. His birds were well shown, and formed a very attractive part of the exhibition.

Poland fowls, as so often happens, were certainly capable of improvement; Mr. Bowman, however, took a first prize for his golden birds; and the same gentleman also exhibited a very good lot of white bearded *Polands*—which we are heretical enough to regard as an improvement on their clean-chinned relatives. Mr. Pennington's *Silver-spangled* birds were deservedly noticed. Both these pens were winners at Bodmin, and, consequently, appeared here as extra stock. Among fowls of *any distinct breed*, Mr. Wingfield took a prize for his *White Silk Fowls*. These birds are as easily kept within bounds as *Shanghaes* themselves, and are excellent layers, sit well, and as mothers are not to be surpassed. A gigantic pair of "*Brahma pooltra*" fowls, recently imported, and the property of Mr. Bowman, were very striking objects.

Mr. Williams was victorious with the same pen of *Gold-laced Bantams* that were at Truro. Exhibitors in this class should study the meaning of the word *lacing* as distinguished from *spangled*. There were good pens of white and black.

Pigeons formed one of the best collections we have seen for a long time. It would, indeed, have been a hard task to have picked out a bad pair, and few varieties were absent; *Barbs*, *Jacobines*, *Fantails*, *Carriers*, *Tumblers*, *Silver Owls*, *Turbits*, and *Nuns*, were all represented.

In *Geese*, Mr. Williams showed three truly magnificent specimens; and adjoining them, but not exhibited for a prize, were a pair of young *Toulouse* birds, belonging to Mr. Wingfield, and bred from the stocks of the late Earl of Derby. Mr. Williams' three birds together must have exceeded 60 lbs.; and, as we noticed that one of the *Geese* was afterwards transferred to Mr. Wingfield's pen, we should augur well for this class at the next exhibition.

Mr. Williams's *Turkeys* were excellent, and adjoining them we found the *Pea fowl* of Mr. Bolitho in better condition than we ever remember to have seen their race at this or any other exhibition.

Mr. Bedford's *Aylesbury* and *Call Ducks* were first-rate, and his black *East Indian* would have stood in the same post of honour, had not the third been marked with a few white feathers. When we say that Mr. Williams's *Ducks*, of the common breed, weighed 26 lbs. the three, further improvement is hardly to be looked for.

This closes our list; and the verdicts of Mr. Andrews cannot but satisfy the members of this society that their past efforts have succeeded, while their future labours are abundantly encouraged. When we hear from such authority that *Shanghaes* were shown at Penzance as good as what appeared at Birmingham, in December last, and that other classes were so deserving of high honour, we feel secure that *Cornish* energy, remembering its good old motto, "*One and all*," will successfully carry out the good anticipations of those who, in different parts of the country, have already so zealously aided the interest of the poultry-keeper. Thus combined, we shall take the surest means for rendering these institutions permanently useful; and, by forming one society for the Western Division of the County, avoid the manifold objections of the minute subdivision of small local associations.

In the following list those classes are omitted in which no prize was awarded.

SPANISH (Cock and two hens of any age).

Class 1.—First prize, 1, Mr. W. J. Lawrence, Penzance; second prize, 2, Mr. W. C. Pennington, Penzance.

GREY DORKINGS (Cock and two hens of any age).

Class 3.—First prize, 8, G. Williams, Esq., Trevince, Truro; second prize, 9, E. H. Rodd, Esq. Penzance.

GREY DORKINGS (Cockerel and three pullets, chickens of 1852).

Class 4.—First prize, 13, G. Williams, Esq., Trevince, Truro.

WHITE DORKINGS.

Class 6.—Second prize, 19, G. Williams, Esq., Trevince, Truro.

COCHIN-CHINA OR SHANGHAE (Cock and two hens of any age).

Class 7.—WHITE.—First prize, 37, R. H. Bowman, Esq., Penzance. BUFF.—First prize, 29, Mr. W. J. Lawrence, Penzance; equal second prizes, 26 and 28, R. H. Bowman, Esq., and the Rev. W. W. Wingfield, Gulval.

COCHIN-CHINA OR SHANGHAE (Cockerel and three pullets, chickens of 1852).

Class 8.—WHITE.—Second prize, 40, R. H. Bowman, Esq., Penzance. BUFF.—First prize, 45, Mr. W. J. Lawrence, Penzance. Both classes of *Cochin-Chinas* very meritorious.

MALAY (Cock and two hens of any age).

Class 9.—Second prize, 60, Mr. W. J. Lawrence, Penzance.

MALAY (Cockerel and three pullets, chickens of 1852).

Class 10.—Second prize, 62, Mr. W. J. Lawrence, Penzance.

GAME FOWL (Cock and two hens of any age).

Class 11.—Second prize, 69, P. Grenfell, Esq., Gulval.

SILVER-PENCILLED HAMBURGH (Cock and two hens of any age).

Class 17.—Second prize, 75, P. Grenfell, Esq., Gulval.

SILVER-PENCILLED HAMBURGH (Cockerel and three pullets, chickens of 1852).

Class 18.—Second prize, 77, P. Grenfell, Esq., Gulval.

SILVER-SPANGLED HAMBURGH (Cock and two hens of any age).

Class 19.—Second prize, 79, P. Grenfell, Esq., Gulval.

SILVER-SPANGLED HAMBURGH (Cockerel and three pullets, chickens of 1852).

Class 20.—Second prize, 82, P. Grenfell, Esq., Gulval.

POLAND FOWL (GOLDEN) (Cock and two hens of any age).

Class 23.—First prize, 85, R. H. Bowman, Esq., Penzance.

POLAND FOWL (GOLDEN) (Cockerel and three pullets, chickens of 1852).

Class 24.—Second prize, 87, Mr. J. R. Branwell, Penzance.

For any other distinct breed.

WHITE SILK FOWL (Cock and two hens).

Class 27.—Second prize, 91, Rev. W. W. Wingfield, Gulval.

BANTAMS (Cock and two hens).

Class 28.—GOLD-LACED.—First prize, 99, G. Williams, Esq., Trevince. WHITE.—First prize, 102, Mr. W. H. Foss, Penzance. BLACK.—First prize, 105, E. C. Marriott, Esq., Tehidy, Truro.

PIGEONS.

Class 29.—First prize, 107, Mr. W. Adams, jun., Penzance (*Carriers*). First prize, 108, Mr. J. Fox, Penzance (*Barbs*). First prize, 111, Mr. W. Wearne, Penzance (*Black Fantails*). First prize, 116, Mr. J. Fox, Penzance (*Jacobins*). First prize, 117, Mr. H. Baynard, Penzance (*Turbits*). First prize, 118, Mr. J. Fox, Penzance (*Nuns*). Equal first prizes, 119 and 120, Rev. W. W. Wingfield, Gulval, and Mr. J. Fox, Penzance (*Trumpeters*). First prize, 121, G. Williams, Esq., Trevince (*Tumblers*). First prize, 127, Mr. H. Baynard, Penzance (*Silver Owls*).

GEESE.

Class 30.—First prize, 130, G. Williams, Esq., Trevince, Truro.

DUCKS (Drake and two ducks).

Class 31.—AYLESBURY.—First prize, 134, J. S. Bedford, Esq., Pendrea. OTHER VARIETIES (COMMON)—First prize, 140, G. Williams, Esq., of Trevince. COLOURED CALL.—First prize, 144, J. S. Bedford, Esq., Pendrea. WHITE CALL.—Equal second prizes, 146 and 147, Rev. W. W. Wingfield and A. Smith, Esq., Mr. Wingfield's birds being *Coloured Calls*.

TURKEYS (Cock and two hens).

Class 32.—First prize, 132, G. Williams, Esq., Trevince, Truro.

PEA FOWL.

Class 32.—First prize, 133, W. Bolitho, Esq., Chyandour.

GUINEA FOWL.

Class 33.—Second prize, 148, W. Bolitho, Esq., Chyandour.

SILVER PHEASANT.

Class 33.—First prize, 149, Mr. W. J. Lawrence, Penzance.

ON THE DESTRUCTION OF THE WIREWORM.

OF all the annoyances the gardener is subject to, and they are not few, there is none, perhaps, so universally bemoaned as those caused by the ravages of the wireworm.

The kitchen-gardener has his potatoes, turnips, carrots, and even his onions speckled and disfigured, if not materially injured, by the enemy; but it is to the floral-gardener that it proves the most unmitigated pest. Snails, slugs, caterpillars, and a host of other insect depredators, if not entirely vanquished, can be tolerably kept under, by care, industry, and watchfulness; but the wireworm, insidious foe, defies all ordinary efforts. Hand-pick every spade of fresh earth; search as you will, there are sure to be some left to torment you; and trap, catch, and destroy them as you may, there is always a friend or relation left to revenge their deaths. And after leaving his favourite Pinks and Pansies over night, apparently in rude health, the unhappy florist too frequently rises in the morning to find some of his choicest varieties (for the rascals invariably prey on these, and gradually on such as he has fewest specimens of) prostrate, and with flaccid leaves, giving melancholy notice of the destroyer within.

It is unfortunate, too, for florists, that the soil which is their staple is that in which the enemy makes his chief abode; for he, like most plants, luxuriates in old pastures, and hence there is annually brought into florists' gardens the very foe they are most anxious to keep out. Your readers, therefore, will, I dare say, not unthankfully receive any information as to the means of resisting the common destroyer.

As I have no claim to be a professed or practised writer on gardening matters, I will, as the most convenient mode of imparting my small knowledge on this subject, shortly explain how I first made sorrowful acquaintance with the marauder; what experiments I tried to get rid of his companionship, and their results.

Some few years since, having entered on a small piece of ground for gardening purposes, the soil of which had not been disturbed, so far as I could learn, since the days when Adam was a gentleman, I caused the turf to be peeled off, set in a heap, and in due course made of it my south border—the old soil being excavated, and the decayed turves placed therein, to the depth of something like three feet—meaning there to grow most of my florists' flowers.

I was advised, by a more experienced gardening friend, that as I should probably find a few wireworms (a hint I found to be strictly correct, except in regard to the fewness alluded to), I, under his direction, planted the border the first year with culinaries, and certainly some marvels of the vegetable world were produced. Horn earrots particularly presented proofs of the numbers, industry, and appetites of the wire-workers, and were worthy of exhibition as curiosities of horticulture; indeed, all the bulbous vegetables suffered much in the same way, where they survived the attack; but, generally speaking, they were, as the Americans say, regularly exquostulated altogether; but the lettuces, which I planted, again and again, seemed to be the great attraction for the vermin; hardly did these get fairly established, and begin to prick up, than one after another they laid down their leaves again, and I frequently picked ten or twelve fine, fat, shiny, golden fellows from the stem and roots of one small plant, besides others of their friends from the immediately surrounding soil, who were, to all appearance, hastening to the banquet.

When this had occurred the third time, I hastened to take further counsel of my gardening friend. He laughed at my lamentations, of course; for do we not all laugh at our neighbour's small misfortunes when they do not affect ourselves? However, he and other authorities, written and oral, that I consulted, having recommended salt, soot, lime, and a variety of other nostrums, I, after a great deal of consideration and tapping the vacant head, set to work to try some experiments.

I took six wine-glasses, and having first placed in each ten or a dozen of my golden friends—No. 1 glass, I filled up with soot; No. 2, with salt, moistened; No. 3, with salt, dry; No. 4, with powdered lime, slaked; No. 5, with powdered lime, unslaked, and afterwards added sufficient water to slake it; and No. 6, with genuine guano. To make my story as short as possible—at the end of a week my friends in Nos. 1, 2, 3, and 4 glasses, were all as lively as grigs; those in No. 5 were mostly dead, but some two or three still survived, though wonderfully shaky, I confess; while those in No. 6 glass were as dead as door-nails, and were so, I

may mention, twenty-four hours after the guano was applied.

This satisfied me that soot, salt wet or dry, and slaked lime, were useless for my purpose, and that even the application of quick-lime, in practice, would be equally so; because, if applied to the soil, the wireworms would have opportunity to escape from the evolution of heat and gases, which they had not in the glass; the only satisfactory result which seemed to be obtained was this, that guano was the destroyer if it could be applied so as to be brought in contact with the victims.

It occurred to me also, that if the guano could not be applied to destroy, it might be useful to protect, so I tried this further experiment. I again, in the same ground where the plants had been destroyed before, planted eleven more rows of lettuces, eleven in a row; round each plant of each other row, and about two inches from the stem, I drew with my finger a shallow drill, and therein strewed a liberal sprinkling of guano, and lightly covered up the drill again. The result was, that every plant unprotected was consumed by the enemy, while all the plants (with one exception) with the guano round them, grew to be respectable members of lettuce society; in fact, of rather gigantic dimensions too, and were consumed on my table; and the loss of the solitary exception I have spoken of, I attribute to having enclosed when planting (though I used great care in this respect) a straggler from the enemy's camp within my guanoic circle, and he, finding no escape open to him, resolved manfully to die in his vocation, for I only found one solitary fellow in the plant, when, after a fortnight or so, I pulled it up on observing it indicate symptoms of being wirewormed.

Believing guano, therefore, to be the ascertained specific for my complaint, I soon after gave the border a stiff dressing of it; but still, during the whole summer, kept trapping with potatoes for the wireworms, and with tiles laid on the surface for the beetles, of which, as your readers, of course, are aware, the wireworm (so called) is the larva, and in which capacity he is said to serve a destructive apprenticeship (and oh! how willingly would florists cancel the indentures) of four years before changing to the mature insect. By these means, and by continually stirring the surface of the soil, I much abated the nuisance, and it is well to observe that the last-mentioned application is of immense service. The wireworm has a rooted antipathy to the iron tooth; this is shown by his natural choice of habitation in pastures, old hedgerows, and the like, where the rake and the hoe never reach him. Again, we find him burrowing just beneath the surface; the rake routs him out, and even the superior worm, Man, finds it aggravating to be turned out-of-doors just as he is sitting down to feast. We shall not, therefore, prematurely conclude that the frequently moving the surface makes the place so distasteful a residence to the gentleman whose habits we are discussing, that he will be inclined to move off as well as a wireworm's locomotives will enable him; and when his time of metamorphosis arrives, he will seek for his progeny a home where some more feeling, but less industrious gardener, will not so frequently invade their repose.

The second season, I planted my border with cabbages, and followed them with Brussel sprouts and brocoli. All these clubbed handsomely, not their money, but their roots; so I did not, as you may imagine, get first-rate produce. During the summer I again, at all convenient seasons, trapped and stirred as before, and by the second autumn had reason to believe that I had fairly fought and conquered, for the ensuing spring I planted pinks, pansies, ranunculuses, picotees, and polyanthuses on the field of battle, and suffered no injury of consequence, either that year or afterwards.

Acting on the experience thus gained, I now invariably freely sprinkle each layer of my annual supply of turf with guano, as it is laid up; and the heap being well exposed to the air by being chopped over several times during the two years it is kept before use, I do not find the manure too stimulating, and I do find I rarely suffer from this most terrible of florists' plagues. Whether quick-lime could be applied in sufficient quantities to have effect without rendering the soil unsuitable for floral purposes, I am not able to say; but I have ascertained, from unquestionable farming

authorities, that lime mixed, in quantities quite incompatible, I am sure, with floral cultivation, with the soil from old hedge-row borders, although left to stand some months in a heap, is not effectual to exterminate, although it is believed it destroys, as no doubt it does, great numbers of the pests.—J. S.

THE DUBLIN AMATEUR POULTRY SHOW.

THE attention of the Managing Committee of the Amateur Poultry Society of Dublin has been called to a report which has been published in the number of your Journal issued the 6th instant, and which you state was furnished to you by Mr. I. J. Nolan.

Had you not given the name of your correspondent, we should not have been at any loss to trace the source from whence the report emanated; and had Mr. Nolan confined his abuse to us and our mismanagement, we should have treated his remarks with silent contempt; but, when he has the effrontery to impute dishonourable motives and a biassed decision to the gentlemen who acted as judges upon the occasion, we deem ourselves called upon to rebut his assertions, and give them the most unequivocal contradiction. Perhaps the language in which we write may be deemed strong; but can we pass over in silence the following portion of his report without feeling indignant at the imputations contained in it? He says, "Our judges are, unfortunately, the relatives or friends of the exhibitors; and what *Irish* judge is so immaculate as not to feel an erroneous prejudice in favour of his friend, particularly when they walk *out* with printed catalogues in their hands?" He does not, and dare not, venture to assert that they walked *in* with them, or ever had them previous to the adjudication, or could have had any idea of the ownership of the birds on which they were about to adjudicate. He further adds, "that he would advise, that, as at the English shows the judges be brought from a distance." We feel it our duty to state, in reference to this remark, that, apprehending it possible that Mr. Nolan, or such another, might make this objection, every endeavour was made by us to obtain a third judge from England, having previously obtained the assistance of two gentlemen who live at a distance from Dublin exceeding at least forty miles, and who were wholly unacquainted with the ownership of the birds exhibited. Those judges were The Hon. Walter Arbuthnot, of Harristown, near Kinnegar; and Thomas Rutherford, Esq., of Mooretown House, Ardee; the third judge being also a gentleman of high standing, but living near Dublin, and who kindly consented to act, at our urgent request, when at the last moment it was found impossible to procure a third one from England.

Now, Mr. Editor, let us look at the facts. You are aware that strict punctuality on the part of the public cannot be commanded; and although 9 o'clock A.M. was the hour named for all the birds to be in the room, it was full 10 before all had arrived; and more than 11 before all were arranged in the different pens. Shortly after which the judges, furnished with a book in skeleton only, commenced their labours; and at 1 o'clock P.M., the hour announced for opening the doors had arrived, they had only given their decision upon the different varieties of the Gallinaceous Poultry, the public became clamorous for admission, and, in order to keep faith with them, the Committee thought it prudent to defer the judging of the Ducks, Geese, and Turkeys, until the following morning.

Mr. Nolan also refers to mismanagements, and says, "he regrets, that either by neglect or design, some Aylesbury Ducks are called Labrador, and improperly classified, or entirely omitted." There was but one lot of Ducks out of its place, which was caused by want of room; and they did not belong to the lady whose name he makes so free with. He further says: "how the Managing Committee could mistake the *White* Aylesbury for *Black* Labrador is of difficult explanation." We beg to assure you, Mr. Editor, that we are not quite so stultified as not to know the difference between *black* and *white*. And we also take this opportunity of informing Mr. Nolan, or, as he is pleased to style himself, a "true fancier, and the oldest Amateur in Ireland," that the Labrador Duck is a pied Duck, "*Fuligula Labra-*

dora" of Bonaparte, a very scarce marine bird, and is not the black variety of the common duck, commonly known as the Buenos Ayres or South American Duck.

We have the honour to be, Sir,
Your most obedient servants,

J. R. DOMBRAIN,
W. B. SELWOOD,
RICHARD P. WILLIAMS, } *Managing Committee.*

Dublin, 17 January, 1853.

TO CORRESPONDENTS.

STOVE CLIMBERS (H. B.).—Turn out the *Combretum* by all means, and close spur it. There is a mass of confusion among the *Ipomæas*. The one you ask about (*I. jalapa*) has a light pink flower. The true *Jalap ipomæa*, is about as hardy as the *Mandevilla suaveolens*. We flowered it in the open air, close to London, in 1838, while the good people in Edinburgh were training it over the stoves. It is in the garden of the Horticultural Society, we believe. *Jasminum grandiflorum* stands three times more heat than the *Mandevilla*, but both are very hardy, greenhouse plants. All the *Jasmines* put together could not be compared to a fine-grown *Mandevilla*, but it requires enormous room to bloom well.

CAPE BULB (W. D.).—The description of the bulb being "very scaly," puts it out of the whole order of Amaryllids. There is no known bulb in all Africa which comes near your description. Without a flower and a leaf, no one can truly say what way a bulb ought to be treated, and there is not the least reliance on the names sent home from the Cape growers. We could publish the names of some parties at the Cape who make a regular practice of deliberately cheating their customers by the use of false names to bulbs.

POULTRY FEATHERS (Scrutator).—Your enclosures of gold and silver-laced Poland feathers have been received. They are very good, especially the silver, and, provided other necessary points of excellence are present, we should be glad to know whether you have any to part with. But you must not forget that a "spangled" Poland ("splashed" we should agree with you in discarding) is a recognised variety, and need not be opposed to your laced birds. But in reply to your communication, as also with respect to that of Mr. Brent, we must have more to say another week.—W.

AMARYLLIS (An Amateur, Dublin).—You bought some of these without names; they are kept dry in pots in a stove, since October, and two of them show flowers, and you give them water, but are puzzled what to do with the rest, some of which are now growing. Your bulbs are of the *Hippeastrum* section of Amaryllids. Friable yellow loam, such as you would choose for Strawberries in pots, for Melons, or for Pine-apples, reduced slightly with a little sand, is the best for all this race. Once in six years is often enough to repot them, and that should be done as soon as the leaves are full grown, or if the soil gets wrong, and you wish to change it altogether, you must repot whenever you see the points of the first two leaves rising in the middle of the bulb. At this early season, 60° is hot enough for those in growth, and 45° for such as are yet dormant. In the yellow loam, and in this heat, one watering a week will be enough for them till the middle of February. When the leaves are full grown they will stand great heat, and water every day; before then you will see more about them in these pages.

FLOWER-GARDEN PLANS (Queen Mab).—Your plan has come to hand, and is just one of those sorts that we are so desirous to publish. It shall appear soon. (W. S.).—Another very good plan in a different style, and will follow that of her Majesty's, when the planting will be somewhat improved; but you had it very near the mark last season.

PURE-BRED CHICKENS.—"I am sorry to see you have inserted two words in my communication, at page 292 of the number of THE COTTAGE GARDENER, for the 13th of January, 1853, by which additions you have quite changed the sense, and altered my meaning. I allude to the word "during" at line 47, and "without" at line 48; to be more explicit, I wished it to be understood, that if a hen had been with a cock of a different breed, that after her removal from him, and being placed with one of the same sort as herself, that in three weeks after her removal, it is my opinion that her eggs may then be depended on to produce pure-bred chicken; my trials went to prove that fourteen days were sufficient, but I prefer three weeks for certainty."—B. P. B.

COMBS OF DORKINGS.—"I must beg to differ from you respecting the combs of Dorkings; as all the true old-fashioned Dorkings I have had, or seen, have had rose-combs; and it is my belief that the single combs are to be attributed to the crosses with large single-combed varieties, by which their size has been so much improved. I do not think a single comb any objection, if the fowl is to be eaten; but, as a point of breed, I consider it of as much importance as a short neck, short white legs, five toes, or square build."—B. P. B.

CANKER IN PIGEONS.—"Perhaps the following may be useful to your correspondent, 'J. T.'—This disease shows itself in lumps of yellowish-white fungus-looking pus, in the mouths, throats, and on the heads of pigeons, and very often causes death; the matter has a very offensive smell, and is infectious. I think the infection is communicated by drinking at the same water, therefore it is advisable to remove the infected pigeons from the others. Fanciers say it is caused by foul water, drinking from tin vessels, or by pecking each other. I have had it occur where none of these causes could affect them. I am inclined to think it sometimes arises from their not having green food, such as clover, lettuce, cabbage, &c.; or too much salt may cause a predisposition. Burnt alum and honey is recommended to anoint the parts with. The Germans remove the lumps with a sharp piece of wood, and apply tobacco juice from a pipe to the wounds; but I have found caustic applied to the wounds, after removing every particle of the matter, to be the surest remedy; do it effectually, but carefully. I have only once lost a pigeon

from the use of caustic, and have cured a great many; before I used caustic, I lost more pigeons by the canker than all other diseases put together; if the old ones are ever so slightly affected, the young ones are sure to catch it."—B. P. B.

FRUITING PINES (Forebridge).—We should prefer planting - out Pines; but if you are very particular about succession, perhaps the pot system would suit best. Pots may be removed with the ripe fruit, and retarded in a cool room for weeks. This cannot be done by the other plan.

CIRCULATION OF AIR (1001).—Putting large bottles filled with hot water in cold pits, to promote a circulation of air, is of most importance in very dull still weather; but a little air must be left on by easing the sash at the top and bottom. Such bottles would also be useful in small greenhouses in sudden frosts, when covering was defective. In such a case, shut up close; but when severe frosts come, it is best to keep shut up, and depend upon sufficient covering. As has frequently been shown, the plants will take no harm from closeness and darkness for a considerable time, provided the temperature inside is such as neither to excite them to grow, nor split their tissues by freezing. For *cuttings*, *bell-glasses*, &c., see an article by Mr. Fish in this number.

COMBINING A GREENHOUSE AND VINERY (W.D.A.).—This subject will receive more attention before long.

ROUP IN SHANGHAES.—Mr. W. Lort says, "The best treatment I know of for roup or roup in *China Fowls*, is to remove the bird at once from the rest, wash its bill, nostrils, and throat well with salt and water warm, and place it near the fire, in a clean, well-aired basket or box, littered with a little dry straw. Cram with three pills, each the size of a horse-bean, composed of equal proportions of chopped rue and butter. The dose may be given again in twelve hours, and then discontinued if the bird appears to be too much relaxed; if not, repeat it after the two first doses every twenty-four hours, until the discharge from the nostril has diminished. Feed liberally from the first (beginning an hour after the first dose of rue and butter) with bread soaked in water, and plentifully sprinkled with brandy. A small quantity of beef or mutton suet should be given every three or four days. As much ground ginger as will lie upon a shilling may be substituted for the brandy once each day, and as the bird improves, give a little well-soaked corn, and a few cayenne pods. Gravel or grit should never be withheld under any circumstances from fowls in confinement. If scouring should continue after the rue and butter have been withheld for a day or two, mix baked wheat flour with the food. In the above treatment I attach much importance to the bird being placed in a dry, warm place, free from draughts, and to the frequent cleansing of the nostrils. The brandy is, doubtless, a great help."

POULTRY.—Dyke had better write to some of the prize winners at the Great Metropolitan Show for the varieties he requires.

BLACK SHANGHAES (E. Bateman).—It is probable that there is no separate prize offered for these, because there is much reason to believe that they are merely the accidental production of a cross between the white and buff-coloured birds.

DAMSON WINE (D. B.).—It must be left in the cask for some months yet, and then be fined with isinglass like other wine.

ENGLISH BOTANY (C. N. S.).—Sir J. E. Smith's *English Flora* will suit. The four volumes may be met with cheap enough at the dealers in second-hand books.

WORK ON POULTRY (A. M.).—We have had no opportunity of examining the work you mention. That which we referred to, you will have seen advertised in our last number.

SHANGHAE FOWLS.—Y. Z. says:—"Four friends of mine here (Westmoreland) have each lost their Shanghae cocks of 1851 hatch. They all appeared to suffer in the same way, beginning with lameness, and then gradually pining away, becoming complete skeletons. There appears to be a feeling that this *northern climate* will not suit them, and that cold is the cause of the disease; they went with other fowls, in two instances, in farm-yards, were well cared for, and tolerably well fed. Have other parties suffered in the same way, or what in your opinion is the probable cause? Do not those fowls require to be kept up, and have better treatment than those usually found in the farm-yard?" We do not think that Shanghaes are more tender than other varieties; but we think that they are more liable to cramp, and loss of the use of their legs, by exposure to excessive wet. Such has been the character of the present winter, and probably more so in Westmoreland than elsewhere. Dryness and moderate warmth are the best preventives of such seizures.

EGGS (G. Osburn).—It is quite impossible for us to answer for the goodness of those advertised. You must write to the parties and judge for yourself.

GALVANISED IRON NET-WORK (G. G.).—Read Mr. Fox's advertisement. You will see what work on poultry we referred to, by our answer to "A. M."

GRASS WALK (Also an Old Subscriber).—We should have no objection to have a grass walk four feet wide within one foot of the wall on which your fruit is trained.

MR. COOPER (A. F. M.).—This gentleman, who obtained a Certificate of Merit at the Great Metropolitan show, also exhibited at Winchester. You had better write to him.

A POOR MAN'S WELL-WISHER.—We have your paper, but prefer the sketch of your life. We shall be glad of any facts relative to weights, &c.

TRIPTILION SPINOSUM.—Typo enquires where he can obtain seeds of this?

HEATING GREENHOUSE (A. S. W.).—You may heat this (thirty-five feet by twenty feet) by a boiler like that which heats your smaller house. We should use four-inch pipe, as you require high temperatures. The size of the boiler is immaterial, so that you have a surface of three square feet exposed to the fire.

EDWARDSIA GRANDIFLOEA.—E. P. B., writing from the county of Dublin, says, "In your number of December 16, there appears a notice from a correspondent, stating, as an extraordinary circumstance, the *Edwardsia grandiflora* ripening seeds in the open air. Perhaps it

may not be uninteresting to you to hear of the same having occurred in other places. There is a large tree of it here (about 10 ft. high), which, for the last eight years, has ripened plenty of seeds in the open air, and it is a *standard*, facing a north aspect. I have numbers of seedling plants grown from the above seed. This in the *County Dublin*. At a place in the *County Wicklow*, near Rathdium, with which I am well acquainted, there are trees (*standards*) of both *E. grandiflora* and *microphylla*; both of which bear plenty of seeds. And, during a tour I made in 1851, through the *County Sligo*, I observed *E. grandiflora* with seeds on it; this plant was against a wall. These are the only plants with which I am acquainted; and I shall be most happy to send seedlings or seeds to you, if the carriage is paid. I may observe, that in all these places the *Rhododendron arboreum* blooms splendidly out-of-doors, especially in Sligo, for the plants I saw there had several hundred flower buds on them."

CALENDAR FOR FEBRUARY.

FLOWER GARDEN.

ANEMONES, sow; finish planting, b. and e. **ANNUALS** (Tender), sow in hotbed; admit air to daily; water slightly; cover with mats the glasses at night; sow seeds of blue and white *Campanula carpatia* in heat, for autumn-flowering, e.; pot old plants of each, and put in heat for cuttings, b.; sow *Nemophila*, and other *Californian annuals*, to flower after autumn-sown ones; (Hardy) sow in borders, e.; for early blowing, sow in pots in a hothouse. **AURICULAS**, dress, and attend carefully those under glass, as the buds appear. **BIENNIALS** (Hardy), sow, e. **BULBS**, finish planting. **CARNATIONS**, plant, and shelter from cold winds. **DAHLIAS**, sow, and place tubers in hotbed, to break buds for slipping. **DRESS** borders generally. **EDGINGS OF BOX**, &c., may be planted and repaired. (See January). Cut round the roots of *evergreens*, to remove about next July. *Evergreens* removed last autumn may have liquid manure in fine weather. **EVERGREENS**, plant in mild weather, e. **GRASS**, roll and sweep weekly. **GRAVEL**, roll, and weed in dry weather, weekly, and try the *concrete* system. **HEDGES** (Deciduous), plant, b.; (Evergreen) plant, e. **HYACINTHS**, shelter, for they begin to appear. **MIGNONETTE**, sow in pots, and place in hotbed, or hothouse, and greenhouse, for succession. **NEATNESS**, attend to everywhere. **PERENNIALS** (Hardy), sow, e.; plant suckers, slips, and partings of roots; (Half-hardy) uncover, if frosts gone. **PLANTING OF FLOWERING SHRUBS**, complete. **POLYANTHUSES**, sow; earth-up with rich compost. **POTTED SHRUBS**, prune, shift, and dress the soil; pot-off bedding geraniums, &c., from stove pots. **RANUNCULUSES**, finish planting, b. and e. **ROSES**, prune strong ones, and leave some to prune in April for late flowering; manure with cow-dung. **SOWING OF TREE AND SHRUB SEEDS**, complete generally. **SUPPORT**, with stakes, &c., newly-planted shrubs. **TULIPS**, shelter as they are now appearing. **TURF** may be laid, and see that plants are in heat for *cuttings*, such as *Lobelia*, *Verbenas*, &c.

Climbers, such as honeysuckles and jasmines, should be pruned and trained in the early days of the month. *Reduce* to moderate-sized patches such plants as ploxes, asters, veronics, &c., otherwise they will occupy too much space, injure their neighbours, and harbour vermin. *Herbaceous plants* should be planted out from nursery-beds into the borders without delay. *Half-hardy shrubs*, &c., may have their shelters partially removed, closing them up again at night, according to the mildness or inclemency of the season.

D. BEATON.

GREENHOUSE.

AIR, admit freely among hard-wooded plants, such as *Ericas*, *Epacris*, *Diosma*, &c., when the atmosphere is clear, and the outside temperature from 35° to 40°. In damp, foggy, or frosty weather, it is better to use little firing, and keep the house more close, unless you have the means of heating, and so far drying the air before it is admitted—the drying, of course, to take place only when the air is loaded with moisture. When the fog gets into the house, light a little fire and give air, and it will soon be dispersed. All these plants will now want more water, but do not give it in dribbles; after doing it thoroughly, wait patiently until the soil is getting dry. Those in full bloom may have similar treatment, especially if the sun will raise the house to 55°. Those swelling and opening their heads must be lower than 45°, with 10° or 15° more in the middle of the day. **AZALEAS** and **CAMELIAS**, place those swelling and bursting their buds in the warmest end of the house, and you may remove them to the coldest end when in bloom. Supply such rather liberally with water. Those to be retarded, keep as cool as possible, and not so moist. **BULBS**, **CINERARIAS**, and **PRIMULAS**, in flower, assist with manure-water; the double *Chinese Primula* give a warm corner, as it is (especially the white) a splendid object when well grown. The night temperature of these should not be below 45°, if desired to keep them in full bloom, with 10° more in the middle of the day. *Cinerarias*, for blooming, do best at this season in small pots; those desired to make fine specimens in May and June, should not now be allowed to be pot-bound, or be stunted any way, but kept slowly growing. *Forsythia viridissima*, *Deutzia scabra*, and *Weigelia rosea*, will yield their blossoms during this and the following month if slightly forced. Forced hardy shrubs keep at the warmest end of the house at first. *Begonia obliqua* makes a fine conservatory plant in winter, if the night temperature is seldom below 45°. **CALCEOLARIAS** and **GERANIUMS**, keep at the best place for light and heat. All these soft-wooded plants require more heat than the hard-wooded ones; the former shift as necessary. The forwardest of the latter, stopped and shifted before Christmas, tie out and train. Place in flowering-pots those stopped some time ago, and now breaking; and stop more young plants for succession, to be shifted when the buds have broken again. *Franciscea latifolia* and *uniflora*, do well in a conservatory at this season, if they had previously received a little extra heat, after being allowed to become deciduous in the beginning of winter, the wood being well-perfected previously. **FUCHSIAS**, start some favourite kinds, if you can, in a nice, sweet, slight hotbed, as at this season they stand a little bottom-heat well, though, when fairly started, a medium temperature makes better plants than a high one. Cut them well down, and thin the shoots afterwards to as many stems as you may

require. The young shoots taken off, treated as cuttings in the hot-bed, under a handlight, or shaded, will make choice summer and autumn plants. Repot those for the greenhouse by the end of the month, and prune back freely; those intended for cottage windows had better remain in their winter quarters for another month, keeping them rather dry, and as cool as possible, so that more room at present may be afforded to other plants. The same HOTBED would do for *seeds, cuttings, &c.*; and also for starting some *Achimenes, Gesneras, and Gloxinias*—the two former either in the pots in which they grew, or by removing the tubers, and placing them in pans with light earth, until they grow a little; the latter either in their late pots before they spring, or, what will do as well, in fresh pots and soil, so that, whenever they start, they take hold of the fresh material. For FIRES, PROTECTION, DRESSING, and CLEANING, see last month. *Insects* will now begin to be busy, and the best antidotes are sulphur vapour and tobacco fumigation, but, above all, cleanliness and good cultivation. SCARLET GERANIUMS: old plants, stored in pits, sheds, garrets, &c., examine. Remove all parts that are mouldy and damped. Dust with lime and charcoal, and expose more to the light, that the young shoots may break vigorous and strong. R. FISH.

FLORISTS' FLOWERS.

AURICULAS and POLYANTHUSES, proceed without delay to top-dress with rich, light, well-sweetened compost. Water them two or three times during the month, giving it only in the morning; give plenty of air on every mild day, but shut up early, and cover up securely every night, for a sudden frost would cripple the blooms. CALCEOLARIAS, repot; sow seed of, keep clear of insects, and give air daily, to prevent damping-off. CARNATIONS and PICOTERS, attend to with water and plenty of air in mild weather. CINEBARIAS, smoke frequently to destroy green fly; repot, middle of the month; give free supplies of water to, and plenty of air. CHRYSANTHEMUMS, put in cuttings of, latter end. DAHLIAS: look over the roots, and remove all decayed bulbs. Set some in a warm place to start growth, and afford cuttings. FUCHSIAS, pot, latter end; put in cuttings of scarce sorts early, to afford good blooming plants in July. HYACINTHS, protect from severe weather, with hoops and mats. PINKS, in fine weather stir up the surface of the soil; press any that the frost may have disturbed down into the earth again. RANUNCULUSES, plant early in the month, choosing a dry day for that purpose. TULIPS, shelter from frost and heavy storms of rain, snow, or hail. VERBENAS, look to, trim off all mouldy leaves, give water to when needful, and plenty of air every day, not actually frosty. WATER, give to all florists' flowers in pots. Should the green fly appear, promptly destroy it by tobacco smoke. Look after SLUGS in the frames or pits, and destroy them. T. APPELBY.

PLANT STOVE.

AIR, give freely on all proper occasions, but shut up early in the afternoon. CUTTINGS of various plants desirable to increase may be put in towards the end of the month. DIVIDE HERBACEOUS PLANTS, such as *Achimenes, Bilbergias, Tillandsias, Vriezia, and Hedychloris*, repot and divide also. IXORAS (specimen plants), repot; prepare young plants of, to make specimens by potting, tying-out, and giving more heat and moisture. INSECTS, diligently extirpate, by every means, such as cleaning the plants with a sponge, smoking with tobacco frequently, and washing the pipes with sulphur-water to destroy or keep down the red spider. POTTING: this is the month to go through the whole of the plants and repot them; get batches of such things as *Achimenes, Gesneras, and Gloxinias*, be potted from time to time. WATER, give freely as the plants grow and the days lengthen. SOILS, prepare for use by placing them under cover to dry and warm. SYRINGE: use this instrument almost daily, to give moisture to the air, and refresh and cleanse the leaves of the plants, and to keep down the red spider. Let everything be kept clean and sweet, let no decaying leaves be seen, nor moss appear on the pots or walls. T. APPELBY.

ORCHID HOUSE.

THE season has now come when the general potting of the orchids will be needful. Numbers will be growing, and then is the best time of all for potting. The materials must be provided in good time, in order to be in good condition. Fibrous turves of peat, the same of loam, sphagnum or white bog moss, charcoal, and broken potsherds, are the principal articles wanted. New or well-washed pots must also be provided. The turf should be brought under cover and placed where it will become partially dry. It might be laid upon the pipes or flues for that purpose. AIR will, during the month, be frequently necessary. To keep the house up to the mark of *proper heat*, good fires will be necessary, and if the sun should break forth, the thermometer will run up rapidly, and then air is necessary to reduce the heat. BLOCKS: the plants on these will require the syringe to be used daily; refresh such plants on them as need it, with new blocks, before the plants begin to push forth. BASKETS, renew when necessary. If the baskets are made of wire, give fresh sphagnum, and larger baskets, if needful. DENDROBES will begin to show buds of bloom, give water to and repot them as they need it. HEAT: the season of growth for most kind of orchids being come, the heat may be increased 10° by day, and 5° by night. INSECTS must be diligently destroyed. MOISTURE IN THE AIR, increase during the month. A dry atmosphere, now the plants are growing, will cause them to grow weak and spindly, especially *Dendrobis*; let the pipes, flues, walls, and floor be diligently wetted every day, especially in the morning. POTTING, proceed without delay; if the young and tender roots push much before this is done, there is great danger of their being broken off. Watering at the root to plants growing must be given freely. Let all the walls, stages, shelves, window-sills, and the glass, have a *thorough cleaning*, to sweeten the air of the house. In potting, attend to the leaves and stems of the plants, sponge them well over in every part; nothing is so injurious to plants as having their breathing pores stopped with moss or dust. T. APPELBY.

ORCHARD.

APPLES, prune, train, and plant. APRICOTS, plant, train, and cover, b. BLOSSOMS, cover directly, to *retard*. CHERRIES, plant, prune, train. CHESNUTS, plant and sow. CURRANTS, prune, plant, b. CUT-

TINGS of all fruits, plant, b. DRESSING, carry out of all borders; beware of the spade. FILBERTS, plant; hang catkins, and remove suckers. GOOSEBERRIES, prune, plant, train. GRAFTS, collect immediately; put them in a cold corner; in May commence operations at, e. LAYERS, make. MEDLARS, plant. MOSS, remove; use brine. MULBERRIES, plant. NECTARINES, plant, prune, train. ORCHARD-TREES, finish planting and pruning; top-dress old ones. PEACHES, as *Nectarines*; apply sulphur and lime wash. PLUMS, plant, prune, train. PEARS, plant, prune, train. QUINCES, plant. RASPBERRIES, plant. PRUNE, tie. SUCKERS, remove from all fruits. VINES, plant, prune, train. WALNUTS, plant and sow. Watch for the scale, aphides, and other *insects*, and try to utterly exterminate them. R. ERRINGTON.

FORCING HOUSE.

AIR, admit on all occasions, if safe. APRICOTS: see *Peach*. CUCUMBERS, keep good linings to dung-beds; sprinkle bed often; air frequently; bottom-heat 90° maximum. In houses, train regularly, stop occasionally, and give liquid manure, with a moist air heat of 70° to 80°. CHERRIES as *Peaches*, only a lower maximum—say 70° sun heat. CAPSICUMS and CHILLIES, sow, b. FIGS as *Peaches*, only a higher minimum—say 60°. GRAPES, late, keep dry and cool; thin the berries. HEAT, in all cases, in proportion to, and advancing with, light. KIDNEY-BEANS, 65° to 70°; plenty of air, moisture, and a light situation. MELONS, sow; provide beds, &c.; air-heat, 70° to 80°; bottom-heat, 90° maximum. MOISTURE, constantly provide the air with, wherever fire-heat is used. NECTARINES as *Peaches*. PINES (*Fruiters*), rising, increase warmth and air moisture; liquid manure to the roots occasionally; (*Successions*) still dry if in dung pits. PEACHES, disbud, and pinch gross shoots; fumigate occasionally. POTATOES, get out successions. STRAWBERRIES, introduce plenty; keep moist air, frequent ventilations near glass; maximum 65°. TOMATOES, sow, b. VENTILATION, night and day, as long as air, moisture, and heat is secured. VINES, disbud early, and attend to thinning the berry; keep clear of all waste spray. Keep a mellow state of air, neither damp nor dry, but a permanency of air moisture. WATERING, attend to with regularity and precision. R. ERRINGTON.

KITCHEN GARDEN.

ARTICHOKES, defend from frost. ASPARAGUS, plant in hotbed, and attend to that forcing. BALM, plant. BEANS, plant; earth-stir, and transplant from frames, e. BEETS, sow a little for early use; plant for seed, and dig up for storing any left in the bed. BORECOLE, sow, e. BROCCOLI, sow a little, e. BURNET, sow or plant. CABBAGES, plant; sow; and plant for seed. CARROTS, sow on gentle hotbed for early use; attend early to thinning advancing crops, &c.; plant for seed, e. CAULIFLOWERS, attend to, airing, earth-stirring, removing all decayed leaves and slugs; plant out winter standing, should the weather be open and mild, and attend to spring-sown crops (see last month); sow, if required; prick out. CELERY, attend to earthing-up, protection, &c.; leave for seed, and sow a little for early use. CHERVIL, sow. CHIVES, divide and plant out. CLARY, sow, e. COMPOSTS, prepare and turn over. CORIANDER, sow. CORN-SALAD, sow. CUCUMBERS, attend to those forcing; prick and plant out; and sow in hotbeds. DILL, sow, m. DUNG, prepare for hotbeds. EARTHING-UP, perform when necessary. ENDIVE, still protect from wet and severe weather. FENNEL, sow or plant. GARLIC, plant. HORSE-RADISH, plant. JERUSALEM ARTICHOKES, plant. KIDNEY BEANS, sow in succession, &c. Keep a good supply of EARTHS in the dry for immediate use. LEEKS, plant for seed; sow, e. LETTUCES, plant out from frames, &c., of the winter standing, towards the end of the month, and sow in the open border. If short of plants, sow in frames on a gentle hotbed at the beginning of the month. LIGUORICE, plant and dig up. MELONS, plant out for early crops; sow and pot off; attend to this sort of work on a kindly calm afternoon, just before shutting-up time. MINT, force, in hotbed; plant. MUSHROOM-BEDS, make in succession, and attend to those in bearing. MUSTARD and CRESS, sow in succession. ONIONS, sow main crop towards the middle to the end of the month; also plant for seed, if not done; and plant the Underground or Potato onion. PARSNIPS, take up where left in the ground till now; plant or leave for seed; also sow towards the middle of the month, particularly in light soils. PARSLEY, sow. PEAS, sowings may be made both of early and second on the same day, where the soil works well, as the one will be found a good succession to the other at picking-time; also to suit some unfavourable situations, it is well to sow in frames in small pots, or in sods of turf, which is by some thought best, to plant out when a good season offers; also attend to sticking, earthing-up, and protecting other forward crops. PENNYROYAL, plant, e. POTATOES, plant in hotbed of any favourite early kinds; this may be done from the first to the end of the month; also plant out during this month all the main crops, if the soil will admit of it, and plant whole sets in preference to cut ones; also look over those in store, often to keep shoots rubbed off. RADISHES, attend to (see January), and sow in succession either in border or hotbed. RAPE (for salading), sow; (Edible-rooted) sow. RHUBARB, sow in large pans, or open warm border, and attend to that forcing, either indoors, or cover up with pots or tubs and fermenting materials. SAGE and SAVORY, plant, e. SALSAFY, sow, e, in small quantity, for early use. SAVOYS, sow, m. and e. SCORZONERA, sow, e., in small quantity, for early use. SEA-KALE, attend to that forcing; cover up in succession. SHALOTS, plant. SKIBBETS, sow, e. SPINACH, weed, sow, m. SORRELS, sow or plant, e. TANSY, THYME, and TARRAGON, plant, e. TURNIPS, plant for seed; sow, e. VACANT GROUND, dig; weed, &c. There is a right time and a right way of doing everything. Plant out in mild, open weather; wheel out manure, &c., on frosty mornings, or on a fine, dry day; make good use of the hoe on fine, dry days, in stirring among the various crops; look over all in-door stores in rainy weather; and tie the ends of new mats before they are applied to use. T. WEAVER.

LONDON: Printed by HARRY WOOLDRIDGE, Winchester High-street, in the Parish of Saint Mary Kalendar; and Published by WILLIAM SOMERVILLE ORR, at the Office, No. 2, Amen Corner, in the Parish of Christ Church, City of London.—January 27th, 1853.

WEEKLY CALENDAR.

M D	W D	FEBRUARY 3-9 1853.	WEATHER NEAR LONDON IN 1852.				Sun Rises.	Sun Sets.	Moon R. & S.	Moon's Age.	Clock bf. Sun.	Day of Year.
			Barometer.	Thermo.	Wind.	Rain in In.						
3	TH	Smythurus fuscus; hedges.	30.142-30.016	51-34	S.W.	09	38 a. 7	51 a. 4	3 31	25	14 10	34
4	F	Sphodrus collaris; tree rts.	30.191-29.810	55-44	S.W.	13	36	53	4 49	26	14 16	35
5	S	Silpha opaca; tree roots.	29.739-29.641	55-43	S.W.	23	34	54	5 57	27	14 21	36
6	SUN	SHROVE SUNDAY.	30.098-29.648	49-27	N.W.	01	33	56	6 53	28	14 25	37
7	M	Omalium planum; decayed bark.	30.155-29.994	50-41	N.W.	02	31	58	7 34	29	14 28	38
8	TU	SHROVE TUESDAY.	30.178-29.463	53-36	S.W.	38	29	v	sets.	☾	14 31	39
9	W	LENT BEGINS. ASH WEDNESDAY.	29.461-29.111	45-25	S.W.	05	29	2	6 a 26	1	14 33	40

METEOROLOGY OF THE WEEK.—At Chiswick, from observations during the last twenty-six years, the average highest and lowest temperatures of these days are 45.3° and 32.5° respectively. The greatest heat, 57°, occurred on the 3rd in 1850; and the lowest cold, 5°, on the 8th in 1847. During the period 98 days were fine, and on 84 rain fell.

BRITISH WILD FLOWERS.

POPPYWORDS.—PAPAVERACEÆ.

MECONOPSIS.



GENERIC CHARACTER.—Sepals two. Petals four. Stamens numerous. Style short. Stigma from four to six-rayed, convex, distinct from the capsule. Capsule one-celled,

opening by from four to six valves at the top. Placentæ narrow, scarcely projecting. Perennials with yellow juice.

MECONOPSIS CAMBRICA: Yellow Poppy; Welch Poppy or Meconopsis.

Description.—It is a perennial. Herbage tender, brittle, slightly milky-green; its juice lemon-coloured. Stem a foot high, mostly besprinkled with nearly upright hairs, leafy, branched. Leaves stalked, leafleted; leaflets nearly egg-shaped, acute, cut, lobed, or pinnatifid, smooth, somewhat forming an edging to the leaf-stalk; most milky-green underneath. Flower of a full lemon-colour, deliciously fragrant like *Crassula coccinea* and *odoratissima*, or *Mesembryanthemum noctiflorum*; smaller than *Papaver Rheas*; each on a very long, minutely hairy stalk. Petals egg-shaped, and scored near their base. Calyx hairy. Capsule elliptic-oblong, of four or five cells, with as many ribs, or receptacles, which elevate the convex, four or five-rayed, stigma, and, before the capsule bursts by intermediate valves at the top, have the appearance of a short style. By this character the present species has been separated from *Papaver*.

Places where found.—Mountains, among wet rocks, in Wales, Cumberland, and Westmoreland.

Time of flowering.—June.

History.—It has been named *Meconopsis* from *mekon*, a Poppy, and *opsis*, like. So like, indeed, is it to the Poppy, that Sir J. E. Smith, and other distinguished botanists, persisted in retaining it in that genus under the name bestowed upon it by Linnæus, *Papaver cambricum*. It is stated in the last edition of *Withering*, that this was first discovered by Dr. Thomas Johnson, the editor of *Gerarde's Herbal*, but the first description we find of it is in *Parkinson's Herbal*, where he very accurately describes and pictures it under the name of *Argemone cambro-britannica lutea*. It is a plant very desirable to have in moist shady places. It belongs to *Polyandria-Monogynia* in the Linnæan system. (*Smith. Lindley. Martyn. Withering. Parkinson.*)

THE increase in the size of *Turnips*, after their leaves had been wholly removed, is a supposed fact that has been noticed in this work, and has also engaged the marked attention of our contemporaries. Gardeners have long been aware that, in analogous circumstances, either when leaves were so thick that they could not individually be acted upon by light, or part of them had become so matured that the food elaborated by them bore no proportion to their drain on the general resources to support a languishing existence, thinning in the one case, and removing in the other, would be attended with advantage. The only thing that appears out-of-joint with previously recognised phytological opinions, is the assertion, that the *Turnips* increase in size and weight after *all* the leaves, and *green* at the time, too, were removed in autumn. Without any practical demonstration, we can easily fancy how weight and even size might slightly be gained by removing the whole of the foliage from *Turnips* in such a dull, mild, wet

winter as that we have so far passed through; as then the absorbing powers would counterpoise the perspiring. A step farther just brings us to the point on which we are all agreed, namely, that roots, tubers, and bulbs must be kept from growing when we wish to preserve their qualities and powers unexhausted.

Having never, as yet, seen our way perfectly with respect to *all* the generally-received dogmas in vegetable physiology, it is no small pleasure to us to see that these *Turnips* of the "Author of a Word in Season," in unison with some statements from the Continent, have tended somewhat to shake the foregone conclusions of some of our most worthy and learned leaders; but if solitary facts were sufficient to form a principle, then we might have, ere long, a perfect chaos of theories. For example; we generally advise our friends who cultivate bulbs, to look after and encourage the green foliage, if they wish to have fine bulbs and flowers the following season. Yet, some twenty years ago, we assisted in

planting a number of fine Narcissi at the end of a Hyacinth bed. During the season the Hyacinths were splendid, but not a flower or a leaf of the Narcissi appeared; and the conclusion arrived at was, that by some means they had been diseased or destroyed. What was our surprise, on forking up and labelling the Hyacinths, to find the roots of Narcissus quite firm, and very greatly increased in size! We cannot speak of their after history; the facts of their increased size, without having shown growth above ground, are true. How such a result came about we confess we cannot unravel. Sorry should we be to advise any one to trust to such an unusual circumstance; and still as little inclined should we be to build a theory on a few of such facts.

Leaving, then, the total disleafing of Turnips in autumn to stand or fall, as it stands the test of more extended experience, we may safely conclude, in the meantime, that when we wish to increase size, or husband vital energies in roots, stems, or buds, or to obtain fresh and vigorous growth, the *time* and the *circumstances* in which, for these purposes, we arrest the reciprocal action of roots and branches, must form a matter of primary importance. Keeping in view what we have said of the Turnip, we will give a few simple illustrations of what we mean.

Suppose a Peach tree, at the end of September, has a good many laterals, and that the young shoots are yet growing vigorously. In a case of excessive growth we might think of looking at the roots, but at present we deem removing the laterals and pinching the points of the young shoots sufficient; and in another fortnight we may shorten the young shoots. Now, here the reciprocity is arrested, but not all at once; the extra resources of the roots are thrown into the shoots, and, as sun and air play more freely upon them, the consequences are firmer wood and plumper buds. Had this operation been performed, as here stated, six weeks earlier, many of the buds you wished to keep would have burst into laterals.

Again, suppose a young Vine, that you wish to provide with vigorous fruitful wood for next season. For this purpose we encourage every green leaf, and laterals too, as many as we can find room for, and thus increase the root action; but as the wood hardens, and autumn comes, we remove gradually the laterals until they are all gone, and very likely, during October, we shorten the main shoot. Now, we do all this for two reasons: first, because the young leaves formed late throw off more than they assimilate; secondly, though a slight check be given to the roots, yet the increased action previously at work will, before it is exhausted, give an extra supply to the wood and buds we have left.

Then, again, a beautiful little Pine tree, a *Picea Pinsappo*, for instance. It is very healthy, but bushy, and thick as a crow's nest; a small bird can hardly get into it, but the tree will not mount up at all. Take your knife, and (say in April) thin out a great many of the inferior twigs, and the nourishment they stole from the roots will be thrown into the ascending axis of growth.

In the case of an evergreen bush of large size, which

you wish to transplant some two months hence; and you are well aware that many roots will be injured; prune in the top in proportion now; if done in autumn it would have been better still; but, if mild weather continues, it is worth while doing now, as, even in very severe weather, facts would seem to indicate that there is, especially with such plants, a flow of their juices. Now, *here* the diminished head becomes surcharged with juice, and then, when you transplant, this surcharging with resources finds a vent in the causing new roots to be formed. We think Mr. Beaton first called prominent attention to this principle in transplanting.

Lastly, under ordinary circumstances, none have more condemned than we have the practice of mowing or cutting off the leaves of strawberries in autumn after they had ceased bearing; and just because, on all firm, loamy, or clayey soils, it requires a green leaf for the whole of the summer, and plenty of light on it, too, to mature fruit-buds for the following season. But in warm places, and in light soil, we have seen great success under very different treatment. The leaves became spotted in July, and browned by August; and when thus left, the next year's flowers were few and puny. In such cases, the long-stalked brown foliage was no great ornament; but when cut away as soon as the fruit was gathered, the ground forked, and plentifully watered, new foliage shortly appeared, which was short-legged, kept green the whole of the autumn and most of the winter, and yielded crops that, for fineness, could not be mentioned with the poor produce from the unpruned rows. Even this may show our sticklers for "principles" that there are such things as exceptions to rules.

As bearing on the same point, but in another direction, we may mention, that the great proportion of strawberries in pots for forcing, at Trentham and Chatsworth, are rising two year's old, many of them having been forced last year.

F.

THE interest which the study and cultivation of fruits have of late excited, and the importance with which they are likely to be regarded, induce us to give the subject all that consideration and prominence which we usually do to matters which concern the extension or improvement of rural affairs generally. There can be no doubt that this is a subject which has of late years been too much lost sight of; and particularly since the duty of 4s. per bushel on foreign fruit has been removed, the growers seem to have thought that it is one which does not concern them. We shall now lay before our readers a sketch of this branch of rural economy, and see how far they are acting with a due consideration of their own interests in neglecting it. Our observations will be directed to the great orchard districts of Kent, which will furnish good evidence, however, equally applicable to other parts of the country.

It is upwards of three hundred years since Richard Harris, "the king's fruiterer," planted his orchard, called "The Brennet," at Tenham, in Kent. This was not, as some say, the first orchard ever planted in Kent; neither

was it, as some still more erroneously have stated, the first that existed in England. Fruit was grown for commercial purposes from time immemorial before then; but the reason why Richard Harris left his counter and his counting-house to become a Kentish fruit-grower, was the very same that would induce many an equally-respectable fruiterer of the present day to act similarly. It was this: "Having observed that those plants which had been brought over by our Norman ancestors had lost their native excellence by length of time, and that we were served from foreign parts with those fruits: on that account, which he saw no reason for, as neither the soil nor the climate here were unequal to the bringing of them to perfection, determined to try a plantation here; for which purpose, having in 1533 obtained 105 acres of rich land, then called *The Brennet*, he divided it into ten parcels, and then having with great care, good choice, and no small labour and cost, brought plants from beyond the seas, he furnished this ground with them in rows, in most beautiful order."

The necessity for such a complete change of the system which had hitherto prevailed, and the success which attended this experiment were so great, that Tenham became the centre from which all the other plantations emanated. So extensive and rapid was the influence which this example had, that Lambarde, writing in 1570, says, this parish, with thirty others lying on each side of the great road from Rainham to Bleanwood, was, in his time, the cherry-garden and apple-orchard of Kent; and, further, that "the orchards of apples, and gardens of cherries, and those of the most delicious and exquisite kinds that can be, no part of the realm (that I know) hath them, either in such quantity and number, or with such art and industry set and planted."

We shall not stay to inquire into the decline and fall of these orchards, nor shall we trace the causes which led to these results; but, in all probability, the trees were allowed to become aged, diseased, and unfruitful, a succession was not provided, and they became extinct. We are induced to believe that such was the case, for a writer of that time states, that these orchards continued to exist till within memory, when the lucre of planting Hops prevailing, few of them were suffered to remain. From the fact, too, of the writers of the 17th century, among whom were Ralph Austen, Hartlib, Bligh, Evelyn, and Worlidge, urging so strongly the encouragement of orchard planting as being a matter which should engage the attention of the government as well as private individuals, there is every reason to believe that the cultivation of fruits had, to a great extent, been discontinued and neglected. By the writings of these men a fresh impulse was given: new plantations were formed, and new varieties of fruit introduced, the old varieties having been allowed to disappear with the old orchards. The new sorts were as superior to the former as the former were to those of which Richard Harris complained. But these new plantations were doomed, in their turn, to the same fate as all the others which preceded them; and so, in the year 1778, we find it said

that Rainham had "within memory great plantations of cherries and apples, especially on the lands adjoining the high road, and to the northward of it; but the greatest part of them have been displanted some years since." And of Newington it is said, that it "was formerly the greatest part of it planted with orchards of apples, cherries, and other kinds of fruit; these falling to decay, and the price of Hops making them a more advantageous commodity than fruit, most of the orchards in the parish were displanted, and Hops raised in their stead."

We shall give one more instance; it is of Borden, where "the land is fertile, and much covered with orchards, and some years ago more so than at this time, many of them being decayed and worn out, were displanted." Now these orchards of which we have last spoken were, no doubt, those which were called into existence by the writers of the 17th century; but no regular systematic planting and successive cultivation of fruit-trees seems ever to have been kept up in this country; whatever was done was brought about by urgency, and carried out with impetuosity, but no steady, continuous system of operation; and hence the state in which our orchards were at the close of the last century.

We shall continue the subject in our next, when we shall see and be able to judge more clearly of the operations of this system of orchard management.

H.

COVENT GARDEN.

WE have had occasion, from time to time, to expose the evil deeds which are perpetrated in Covent Garden Market; they are neither few nor small. We have to add another this week, which is of a somewhat different nature to what we have noticed before. For the last two or three weeks we have reported "new potatoes," and no doubt many of our country readers were curious to know where they came from—whether they were imported from Holland, raised in frames, or brought from some far-away country, where there is no frost and no winter, but a perpetual summer of perpetual sunshine. They come from neither. They are the produce of that greatest of all gardens—Covent Garden. They don't grow; they require no early planting, no dry soil, no manure, and are liable to no "disease." They are like the poor little chickens that are hatched by hot-water or steam; they have no mother. They are, in fact, handsome, smooth-skinned, medium-sized kidneys, selected from any potato pit or cellar, and well scalded with boiling water to remove the outer skin, and blanched. These are sold for 1s. per pound. We leave our readers to judge of the profitableness of this mode of cultivation.

The same dullness of trade continues, and the same abundant supply of all kinds of VEGETABLES is not diminished. The prices which we have reported for the last week or two are applicable now. *Savoys* from 6d. to 10d. and 1s. per dozen. *Brocoli*, 3s. to 4s. per

dozen bundles. *Greens*, 1s. to 1s. 9d. per dozen bunches. *Brussels Sprouts*, 1s. to 2s. per half-sieve. *Turnips*, 1s. to 1s. 6d. per dozen bunches. *Carrots*, 2s. 6d. to 3s. 6d. per dozen bunches. *Spinach*, 1s. to 2s. per sieve. *Onions*, 2s. 6d. to 3s. per bushel. There is also a good supply of salads. *Lettuce*, 6d. to 1s. 6d. per score. *Endive*, 1s. to 1s. 6d. per score. Small salads, such as *Mustard and Cress*, 2d. and 3d. per punnet. *Beet*, 1s. to 1s. 6d. per dozen. *Potatoes*, 84s. to 150s. per ton.

IN FRUIT, the only description that is at all abundant is Apples, and these only of the more common and nondescript varieties for culinary use. Good dessert sorts make from 8s. to 14s. per bushel; others, 4s. to 8s. Among the dessert kinds we observed the *Scarlet Nonpareil*, a very excellent variety at this season; but the other kinds were what we have so often enumerated before. GRAPES are very short, and make from 6s. to 12s. per pound. There are very few PEARS, the principal being *Beurré de Rance* and *Easter Beurré*, at from 2s. to 6s. per dozen.

PLANTS AND FLOWERS are in abundance; they consist of *Camellias*, *Cinerarias*, *Hyacinths*, *Heaths*, *Scarlet Geraniums*, *Chinese Primroses*, *double and single*, *Tulips*, *Violets*, *Lily of the Valley*, and some very choice *Orchidaceous plants*.

H.

GOSSIP.

IN reply to "Amateur," we certainly did read the editorial in *The Times*, relative to *Poultry Shows*, but we cannot say that we observed in it anything worthy of reprehension. The object of the writer seemed to be to warn the public against losing sight of utility in these exhibitions; a warning in which we fully concur. It is true that the writer indulged in a little raillery, but the same writer aimed similar light artillery against the country meetings of the Royal Agricultural Society. The latter were not battered down by it, neither will Poultry Exhibitions. We happen to have before us abundance of information shewing the good such exhibitions are effecting, and we may, one of these days, arrange this information for publication. At present, let it suffice to say, that such weighty specimens of all the table varieties of poultry are now to be met with in our markets as in former days were not deemed possible; and we know of hundreds now keeping poultry who were roused to an interest in them by the beauty of the specimens exhibited. To increase this interest must be beneficial, for in proportion to its increase must be diminished the large sums expended for foreign poultry and eggs. Of the latter, more than one hundred and fifteen millions and a half were imported in 1851. As to our great contemporary ridiculing our favourite Shanghaes as "large gawky fowls without tails," why "gawky" specimens deserve to be ridiculed; and it is to show that they need not be "gawky" that short-legged specimens are gathered together and rewarded at our exhibitions. Ridicule, in one sense, is a test of truth; and we are quite sure that our Poultry Shows will endure the test; and one ground on which our conviction rests is the certainty, that, as similar exhibitions

have improved the tenants of our gardens, so, by like means, will the tenants of our poultry-yards be made more excellent.

THE following is a copy of a Memorial in the course of signature. When we saw it, there were appended the signatures of Mr. H. Gilbert and Mr. Punchard, and it was to be forwarded to Capt. Hornby, Mr. Sturgeon, Mr. Bond, Mr. Peck, Mr. Peters, and others:—

"To the Committee for Managing the Birmingham Poultry Exhibition for 1853.

"Gentlemen,

"The undersigned exhibitors of poultry at Birmingham beg leave respectfully to represent to you,

"That under your present regulations they are compelled to send off their birds on the Friday or Saturday; and many of them do not reach their homes until the Monday week.

"That so long an absence, added to the confinement to which they are necessarily subjected, operates very injuriously upon valuable fowls, especially at a time when the breeding season is approaching; and this feeling has, to our knowledge, prevented some amateurs from becoming exhibitors.

"That if the days of the public exhibition were reduced to three, commencing on the Wednesday morning, so that the fowls need not be taken in until Monday, two days' confinement and absence from their walks would be saved to them; and if two sets of judges were appointed instead of one, they might, by dividing their labours, complete them without difficulty by four or five o'clock on the Tuesday, so as to allow a private view, to subscribers only, on that evening.

"That by permitting the fowls to be removed by the respective owners, or their servants, at dusk on the Friday, instead of keeping the exhibition open until a late hour of that evening, they would reach their walks some time on the Saturday, and thus two more days would in most cases be saved, and their absence, in fact, reduced by one-half, or nearly so. For these reasons we beg, in our own names, and those of numerous other exhibitors, to request that you will take this matter into your consideration, and make such arrangements previous to the issuing of the prospectus for the Exhibition of 1853, as will reduce, as much as possible, the time during which our fowls are kept from their homes.

"We have the honor to be, Gentlemen,

"Your most obedient servants."

"January, 1853."

The following hint will be useful, we hope, to many who are *planting Orchards*, like the party to whom it was addressed:—

"You are right in determining that the greater proportion of what you plant shall be of the best sorts of *keeping Dessert Apples* and *Pears*. There is an advantage in growing these besides the profit; and that is, you are not so likely to have your orchard robbed. Who, even the veriest urchin, would, in September or October, like to dig his teeth into a *Nelis d'Hiver*, *Easter Beurré*, or *Beurré de Rance*? I knew an old gentleman, and you know how "knowing" some old gentlemen are, who planted the outsides of his orchard with all such, and made known in the neighbourhood that they were all *perry pears*. The natives of course tried the outsides first; but, finding they were so unpalatable, concluded the whole collection was of the same description, and left them to 'hang and grow,' without molestation."

There are some of our readers who, we know, think that the world is growing old; that symptoms of physical decay are apparent in all things—Potatoes are murdered—Grapes are shanked—Vines mildewed—Apples decay—Onions rot—and Dahlia roots gangrene—more than they used to do; and now we have the following from an excellent gardener and good practical botanist:—"I fear the potato blight will extend over the whole vegetable kingdom. My strawberry plants, intended for forcing, are all spotted, and have lost most of their

leaves.—R. B." Notwithstanding all these authorities, we are sufficiently young to think that the present are better than the olden times; and that murrain and mildew, gangrene and decay, will by degrees pass, and be no more thought of than are the Hessian Fly and the Curl—neither of them now heard of—which not many years ago were thought to have rendered our wheat and potato crops scarcely worth culture.

We are very glad to learn that *Mr. Niven*, who has so efficiently superintended the herbaceous department in Kew Gardens, is appointed to the Curatorship of the Hull Botanic Garden.

A correspondent having a sickly *Goat*, has found its health improve since he gave it a small daily allowance of salt, and asks whether this can have been the cause of improvement? The best answer we can give, is this extract from *Dr. Forbes's* excellent volume, "A Physician's Holiday."

"On leaving the *Rothe Kumm* to return to *Zermatt*, our party separated; my two companions preferring to return by the way they came, I choosing to make a bend to the north-east, in order that I might see the *Strahlhorn* face to face, as well as the *Findelglecher*, lying between that mountain and the *Riffelberg*. So we parted company on the top of the *Rothe Kumm*: my young friends taking with them *the goats*, I *the guides* with me.

"This division of attendants needs some explanation; and what I have to give will not afford much novelty to Alpine travellers. In the earlier half of our journey to the top of the *Riffelberg*, we encountered, in passing a patch of mountain pasture, a small flock of goats—five or six in number—which immediately joined our party, and kept close company with us, through the rest of our route, in spite of much remonstrance on our part. After repeated attempts to dismiss them, we were at last forced to admit their society, which was certainly of the closest kind. They intermixed themselves with their new biped friends in the most familiar fashion, pressing upon our heels and hands, and leaving nothing undone to attract attention and consideration. When we stopped they stopped, when we moved they moved, and whatever vagaries we committed they did the same.

"It was really almost pathetic as well as ludicrous, to see the poor beasts gratuitously scrambling up rocks and banks which we might be climbing to get a better prospect, or going far out of their way, if they had one, certainly out of good pasture-ground, in order to bear us company in the pursuit of objects which in no way concerned them personally. When a tempting bit of grass came in their way on the side of the path, or in the crevice of a rock, no doubt they would crop it in passing; but no pasture, however tempting, would really stop them, much less seduce them to the right or left: still on they went, with us, before us, behind us, amidst us, dodging us, nudging us, with all the gravity of the caprine nature, and with a determination of zeal which could only be explained by the spurring on of some great desire hoping for gratification. Even when we had entirely left the region of vegetation, and had to clamber up the stony slopes of the *Rothe Kumm*, our poor friends never left us for a moment, but scrambled with us—much indeed to our envy on account of their superior agility—and rested not until they rested beside us on the very summit. They sat patiently there all the time we did, and then attended my young friends a good way beyond the spot where we had first encountered them.

"The secret of all this marvellous zeal and ostensible affection on the part of the goats, lies in their *fondness for salt*, a delicacy which their experience has told them is only to be found in the society of the human animal, and to gratify their love for which no trouble is thought too great. This love, however, although a natural instinct in the goat as well as other animals, is, I fear, rather a sophistication in the extent to which it is carried by them in their domestic state, a sort of saline dram-drinking which perhaps ought

no more to be encouraged than the cravings of our gin-drinkers. Their wild cousins, the *Gemsen* or *Chamois*, have the same taste for things saline, but they can only indulge it in that more limited degree and unconcentrated form in which Nature presents most of her products to her children.

"*Scheuchzer* tells us that there are certain spots in the Alps, known by different local names, as *Glick*, *Läckinen*, *Silzen*, which these animals are known to frequent in great numbers, for the purpose of *licking* certain rocks, having, or supposed to have, a saline impregnation. For this purpose they are said to travel very great distances, returning to their original haunts after satisfying their longings. The hunters who know these localities do not fail to take advantage of these gatherings, although their prey are said to become emaciated during the prevalence of the saturnalia."

THE VINERY.

AMONGST the numerous inquiries made of THE COTTAGE GARDENER, those concerning the Vine hold a prominent position. Peaches are gorgeous; Pines bear the insignia of royalty; and every idea connected with good ripe Figs carries the stamp of Orientality. But, notwithstanding these attractive characters, which are indeed richly merited, the grape—the luscious grape—is everybody's favourite. Three-fourths, at least, of our garden possessors, who are in respectable circumstances, and who possess their little greenhouse, direct their first steps in exotic fruit culture to the vine.

It would appear, from the character of many queries, that the writers thereof desire to know more of the minutæ of grape culture. Of course, all readers are not precisely alike; all tastes not similar; all conditions not the same. One likes the very fundamental principles of culture; another thinks all such unattractive matters, and would prefer a cut-and-dry routine; and thus the world is compounded. In very truth, thousands who are fond of reasoning over principles are obliged to resort to the latter off-hand way, inasmuch, as they have not time, owing to their many engagements, to wade their way through the mass of conflicting opinions.

The majority of our readers will, by the time these observations reach them, have their vines budding, or, it may be, blossoming; and it will be well to show forth the routine of practice, step by step, through the earlier stages.

It is well known, that during the first swelling of the bud, up to the first peep of the young bunch, the advances made in what is termed forcing cannot be too gradual. If this part of the process be hurried, the probability is that an insufficient number of buds will be developed; those, chiefly, which are farthest from the main stem, and which happened to enjoy a kind of monopoly in the appropriation of the supplies in the preceding summer. This, then, has a tendency to break in upon system, and to render the trees lean in regard of young wood for future years.

The moment the buds acquire size sufficient to distinguish their true character, what is termed *disbudding* should commence, whether on pot vines or those otherwise situated. It must here be understood by beginners, that healthy vines generally may be expected to produce more shoots than it is expedient to leave on them. Now, this disbudding is not a process of a day, nor even of a week; it is essentially progressive; and the latter is a fortunate circumstance, as it affords the operator the means of equalising, in a great degree, the strength of the tree, inasmuch as it compels the subsequent developments to assume a progressive character also—a matter of great convenience as bearing on the operations. It is not easy to say, without seeing the vines, how many buds should be removed, and how many left on, so much depends on the condition and character of the tree. But I may observe, that it requires nearly a

square yard of space (superficial), in the average, to produce a good bunch of grapes of say two pounds. This may make some of our young folks stare, but they should be well impressed with this idea before they proceed with the disbudding.

The fact is, it is altogether a question of light; and the *more roof* of a vinery it is, totally irrespective of all the interior area, that must determine the amount of produce. To produce a fair bunch of well-flavoured grapes, there must be a shoot of about two feet in length, after what is termed severe stopping; and right and left of this, laterals which shade much, and occasionally overlap their neighbours—a thing, however, to be avoided; and at certain times they must be permitted to ramble somewhat freely, for reasons shortly to be offered; so that although the spray may not be confined to a given yard square, it will be found, on the average, to cast a shade on an area nearly equal to a yard superficial. But, although this may at first astonish the novice in disbudding, yet the least reflection will show that this amounts to an enormous produce, taking the quality as well as weight into consideration. For suppose a little house twenty feet long, and having six rafters occupied with vines on the spurring system, each rafter sixteen feet long, here we should obtain above one hundred-weight of grapes; no inconsiderable weight of a fruit so very rich in saccharine principles.

And now let us hope our rising vine-men will study the capabilities of the vine: what *may* be expected, and what *ought not* to be expected. Grievous is it to see, day after day, a fine, strong, and willing horse doing double duty, and, perhaps, badly fed; and equally grievous to a good gardener, to see a willing Black Hambro' doing double duty, and the possessor, perhaps, wondering all the while how it is that his grapes will not turn black, and that they prove of more use in the kitchen than on the dessert-table.

I now return to the digressive point. It will be seen that many buds have to be rubbed off; caution is, however, requisite. Buds sometimes prove deceptions; if the operator were at all times to strip away, what at first sight appears, the weak buds, and reserve only the more coarse, he would not unfrequently find himself mistaken. Some of the gross-looking shoots will occasionally prove barren, whilst others, which at first did not promise much, will prove of eminent service. Thus, then, it becomes the vine-dresser to be chary in his movements, and to suffer the proceeding to stretch over a week or two, which, indeed, is about the period nature herself presents for the operation. And here, I hope to be pardoned for stepping a little out of my way to indulge in an idea that has often struck me, and, doubtless, many of the readers of this work, especially our clerical supporters—it is the singular agreement between the best vine-dressing practice in these times, and that of the days of our Saviour, who, it will be well remembered, draws a comparison between the vine and man. "Every branch in me that beareth not fruit, He taketh away; and every branch that beareth fruit, He purgeth it that it may bring forth more fruit." Here, how plainly we have our disbudding, pruning, and all; or rejection, with the subsequent practice of stopping, training, &c., in order to enhance the value of the fruit. And, doubtless, it was the recognised practice of those days in the open vineyard.

Day by day, then, let the vine-dresser watch the developments, and having enough of young shoots to select from, continue, as their character becomes really manifest, to secure the fruitful shoots in proper situations, and to strip away the worthless; in all these things, keeping an eye on future years, and the system of training he is pursuing. And on the heels of this operation, what is termed "*stopping*," must press. Stopping, means simply pinching off the end of the

reserved shoot, in order to concentrate its strength at a given point; that is to say, the immediate vicinity of the future cluster of grapes. Now, I would fain have the unknowing readers of this work consider how this "stopping" operates; and if I be right, it operates in a twofold way—it concentrates all available power near the fruit, and it is opposed to the increase of hard wood.

Some may say, why should the latter be opposed? But surely the reason is obvious. It is not the vine that has the greatest amount of solidified wood, that has been the most profitable, inasmuch as timber is not the object. A judicious system of stopping, therefore, husbands well the resources at command, and the throwing all possible power into the fruiting propensities of the vine, very naturally keeps down the tendency to produce mere hard wood. I venture these opinions thus far, thinking that in accordance with the temper of the age, the dry rules of the olden time ought by no means to suffice. Philosophising in material things is not alone permissible, but highly to be commended, if conducted on recognised principles, and devoid of dogmatism.

Let stopping proceed, then, according to the rate of development of the young shoots; those reserved may be, according to the usual practice, stopped one joint beyond that where the bunch shows; from this very general practice, based on the recognition of the severe economy imposed in regard to *light*, I see no reason whatever to differ. Where the shoots are robust, it is well to stop them soon after the "show" is well developed. This is a matter of expediency; for just in proportion as these are checked in their rapid career, will be the increased strength of those subordinate shoots which are only awaiting a chance to become useful.

Thus may the stopping proceed until all have been subjected to the process, and by the time it is fully carried out, some of those first pinched will be about to develop lateral shoots, about the stopping of which practitioners slightly differ; some are for pinching their points immediately; others allow them to ramble a little. I do not think it well to be so very keen as to be constantly stopping, but believe it best, for the system of the tree, to allow a little liberty in this respect. There can be little doubt, that the principal increase of root takes place coincidentally with the extension of the spray, and in a close ratio to it; and, if such be the case, it is obviously good policy to suffer a free growth occasionally. However, as before observed, all these things are best done progressively, for so I have found it with all disbudding. An attentive vine dresser will be fingering about his vines almost daily; and there can be little doubt, that supposing a given shoot to possess four laterals that require pinching, it would be better to suffer the operation to occupy a week than to perform it at once.

Henceforward, the stopping will continue at intervals, until the berries commence stoning; by which time, if the vine has a good crop, the rambling propensities will have much diminished; and, indeed, I hold it good practice to suffer the vines to ramble unmolested during most of that period, for, as the berry remains nearly stationary as to mere size, there does not exist the same reason for close stopping.

Where there is a leading shoot required for extension, it, of course, forms an exception to the side or bearing shoots, and must not be stopped so close; especially in the case of young vines advancing up the rafters. It is the practise of some to pinch every lateral from the latter as they are produced. From this doctrine I beg to differ. One of the first objects with the cultivator, in the case of young vines, ought to be to obtain plenty of roots; but how can this be accomplished with this constant snubbing? It is a well-known fact, that the

root cannot extend rapidly without a corresponding extension of branch in any shrub or tree; reciprocity is nature's law in this respect, and may not be altogether set aside. Much care should be taken over the thinning of the berry; many persons thin too freely: this, of course, produces larger berries, but such bunches dish up badly, and require packing. Grapes at table always look best in bold relief; but it is difficult to dish-up over-thinned grapes.

R. ERRINGTON.

MEETING OF THE HORTICULTURAL SOCIETY.—JANUARY 18, 1853.

THERE was a large meeting of the Society this day, which happened to be the finest day for the last three months. The special subjects set apart for this trial, were *hardy winter-flowering Plants*, in any shape they chose to send them; *Grapes of English growth*; and the best and most varied *Salad Plants*: of all of which we had large quantities. There were nearly fifty kinds of out-door plants, in bloom, from the garden of the Society; cut flowers, of course, and done up very nicely in bunches, with a little moss round the bottom, then stuck into little pots or jars, as one would arrange them at home for the mantel-piece, or anywhere about the rooms. In a dirty, smoky-looking place, like London, this kind of gardening is a species of luxury in winter, of which all classes seem to take advantage, more and more, every year—judging from the quantities of cut flowers one sees in Covent Garden market.

I went through the market that morning on purpose to see how they stood there, as compared with our own gathering in the afternoon. What surprised me most, was the cheapness of the nosegays, and the choice of flowers in them, and the excellent way they make them up: Camellias, Scarlet Geraniums, Gardenias, Roses, and Violets, *mixed* up into six-inch nosegays, that is, six inches across the circle, for half-a-crown. A wedding nosegay, as white and as sweet as a Rose or Violet, for 5s., 7s. 6d., to 10s. 6d., according to size. I recollect, one very hard winter, not many years back, when a duchess paid just twelve sovereigns for a bouquet to go to the christening of, I believe, the Prince of Wales, at any rate, of one of the royal children. Since then, I know that 31s. 6d. were given for a small nosegay, in the month of May, that I could buy to-day in Covent Garden Market for sixpence. I mention this to show that we who stimulate the cultivation of plants and flowers have some foundation for giving prizes for cut flowers in the dead of winter, and in the heart of London, where cut flowers are always far more sweet than in the country, as the ladies affirm when they go home to their country seats. Then, as a hint to those who are about to marry; it is now thought quite vulgar to go together without wedding nosegays—all white, if possible; not too big,—say the bride's nosegay four inches across, and those for the bride's-maids not quite so large. I had an earnest request, the other day, from a young gentleman, fresh from his lexicons at Cambridge, to order seven bouquets for his wedding, and to choose the flowers, size, &c., for him. I shall just mention how the bride's bouquet was to be made—a large, double white *Camellia* for the centre; then a close circle of *Gardenias*, with three or four *Orange Blossoms* in little bundles, alternating with the *Gardenias* all round; then an outside border of a *White Narcissus*, having a crimson edge to the eye; guard leaves of the *Rose-scented Geraniums*, and the whole put up in a beautifully-cut white paper. The seven cost only 30s., a hundred miles from London. So we see that cut flowers are very useful in other places, and in country places, too, as well as in London.

Before I come to our cut flowers, however, I must mention a new plant in point, a *Dendrobium*, the only orchid in the room; it was a very dwarf plant, with white blossoms, as much like orange-blossoms as anything you ever saw; and in the lecture it was suggested, that the flowers of this new orchid might be used for any purpose for which orange-blossoms are adapted; which some of us believed to be the most philosophical part of the whole lecture.

The Messrs. Veitch sent up, from Exeter, a small plant of the beautiful *Sonerila*, which was so much admired at the last meeting. Some people spell the name wrong, and few pronounce it right; the stress is on the i, and the sound is like *rye*, or thus, so-ne-rye-la. It is a pity that a wrong sound should be given to the name of so beautiful a plant, which is sure to come into general use, like the *Achimenes*; and, as it comes in when the *Achimenes* are over, and will last on to, and through, January, everybody will have it by-and-by. After flowering it will go to rest, and it may be kept dry, or nearly so, till the beginning of April; then a corner of the cucumber bed will set it off again to the end of May; after that a close pit culture, without artificial heat, will do for it to the end of September; at any rate, that must do where no better means are at hand; then, if it were managed on the single small-pot plan, like Mr. Pince's *Æschynanthus*, no doubt it would be in bloom by the end of September, and fit to go to the drawing-rooms, in succession, along with *Gesnera zebрина*; also on the small-pot culture as I lately set forth. It appears to me, from a slight acquaintance with it, that this *Sonerila* will bear the same degree of hardship in the drawing-rooms as the *Begonia parviflora*, or *Dregei*. At all events, it is more creditable for an old gardener that what he says of a new plant should almost fail, than that he should be so chicken-hearted as to say nothing about it till the rest of the world knew all its points of culture.

The next best winter-flowering plant in the room was from the garden of the Society, *Siphocampylos microstomus rubrus*, with heads of brilliant crimson flowers; a bushy plant, two feet high, and every branch of it ending in beautiful heads. The species, *microstomus*, was there also, from the same collection, but it is not nearly so handsome; the two, however, are well worth growing in quantities for the winter season. The plants were very healthy-looking, and clothed with deep green leaves down to the pot, which is not usual in this gay family. I did not learn how this variety was obtained, but the species is from New Grenada, and is as easily managed as a *Justicia carnea*, and, I should say, much in the same way. Let us follow our practice with this very plant, and say, that after the flowers are over we will give it three months' rest, with no more water than would keep it from shrivelling; then to cut it down close; water it; apply a little stimulus in a warm pit; and when it was again in leaf, to shake off all the soil from it, as we would from a Geranium under similar circumstances; then to trim the roots a little, and put it into a small pot, with a rich, light compost, such as one would use for a pot Fuchsia. After that, to grow it on kindly through the summer, and change the pot two or three times; the last potting not to be later than the middle of July; to keep it rather dry, airy, and sunny, all through September and October, so as to stop the growth, ripen the shoots well, and give them time to form their brilliant heads of flowers before the very dull short days, and then to force them to open, or let them do so without any hurry. Cuttings of the first early shoots, in April, would make the *best* plants; but, probably, pieces of the old shoots would do when the plant is cut down, and, no doubt, an old plant might be divided into three or four divisions at the time of shaking off the soil, and

each of them would make a flowering plant by the following autumn. I think it is better, with all this family, to get all the flowering shoots direct from the bottom, if possible, than to stop any of them to get the plant bushy; and when it is absolutely necessary to have recourse to stopping, it ought to be done very early, when the young shoots are about four inches long.

The next best, if not the very best in the room, was a Brazilian bulb, *Hippeastrum aulicum*; the variety of it, with the wavy petals and sepals, called *platypetalum*. There are three distinct forms of this beautiful bulb *Aulicum*, with thick broad petals, as flat and regular on the edges as the petal of a tulip:—*platypetalum*, our present subject, the petals and sepals wider apart and a little wavy, with the crimson colour not so rich as in the first; and *Organense*, intermediate between the two, and a much hardier bulb, which the late Mr. Gardener found high up on the Organ Mountains, in Brazil. The three never produce more than two flowers on a scape, and the large green eye is very conspicuous on all of them. The best kind to cross with them is certainly *regium* (*reginæ*), the best scarlet in the family. The next best is *equestre*, a bright orange flower, as regular in the outline as the flower of *Valotta*. The bulb exhibited was in a large No. 16 pot, and it had three large offset bulbs still growing on the old bulb; the old and young were all in bloom like a Pine-apple, having three suckers in front, as well as the old plant. The old bulb in the middle had two flower scapes, higher than the side ones; there were six scapes in all, but one of them was over by this time. It is the only *Hippeaster* that was exhibited like a "specimen" for the last twenty years, and the first of the *Aulicum* breed that I have seen with twelve blooms on at the same time. This is always the best way to grow *H. vittatum*, as it is rather shy to establish after dividing; and I was going to recommend it to be grown this way on that account, and as something novel; but now I am glad to own that a first-rate grower of them, and a perfect stranger, has forestalled me, and only wish we had many more such growers of these very handsome bulbs; indeed, of bulbs in general. I hope the Council of the Society will offer a handsome prize some day or other for the best-named collection of well-grown bulbs, and make me one of the judges in that class. There is some danger attending the growth of stove bulbs in general, after this method; the old bulb is always ripe long before the side ones; but I shall explain when I come to that part of our bulb list.

COCHLEARIA ACAULIS.—This is the very little annual which will keep in flower all the year round, and flower on the mantle-piece all the winter in anything from a shell to a finger-glass. If every one of our readers would threaten to take their custom from seedsmen who could not supply a sixpenny packet of the seeds of this pretty little thing, we should soon have it as the Society wish. We had lots of it to-day, in wide shallow pans, the plants standing as thick as grass, and in full flower, and hardly two inches high. They send it every winter, from October till April. *Echeveria* (sounds E-g-v-r-i-a), is another plant of which they have three or four kinds in the garden for showing at these meetings, all of which, we were told in the lecture, might be grown in every window in London. *Gesnera zebrina*, and *G. Herbertii*, both fine specimens, were also from our own garden, as also, and as is usual every winter, a fine example of *Silago distans*, which blooms all the winter through, if done as Mr. Fish says. *Muraltia Heisteria*, the best plant of it I ever saw, was from the same garden. When I was a boy, this was the only greenhouse plant to be seen in flower all through the winter. It was then called *Polygala*. It has very bright red, little, pea-flowers, crowded together along the shoots, and is one of the best of all the old-fashioned plants for this season. *Centradenia flori-*

bunda, only known to stove-plant growers, was there also. There is not much difference between it and *C. rosea*.

To name all the cut-flowers at this meeting is more than I can find room for. Will it not, however, stand as a garden mark in history, that beautiful, large, healthy flowers of the red or scarlet *Datura*, were gathered from the open air in Dorsetshire, and were exhibited in London on the 18th January, 1853! Mr. Strangways sent them, and a large flat basketful of other nice things, in the same style, including the Mexican *Fuchsia cordata*, looking as rich in the flower, and as flowery as any *Fuchsia* ever did. Now this very pretty *Fuchsia* was cast out of cultivation without a hearing; but depend upon it the fault was ours, we did not find out the right method to bring it in as a winter-flowering plant, like *F. serratifolia*. We ought to retrace our steps, and get the two crossed for a regular new breed of *Fuchsias* that will flower naturally all the winter. There is not the slightest doubt about the possibility of the thing.

There were plenty cut-flowers of *Camellias*, *Cinerarias*, *Epaeris*, of the two *Chimonanths*, *fragrans*, and *grandiflorus*; their sweet flowers were a great treat for the ladies; *Lonicera fragrantissima*, an evergreen hardy bush, very sweet-scented white flowers, and many more besides.

A fine *Enville Pine-apple*, and lots of *Grapes* and dessert *Apples*. The *Black Barbarossa*, from Mr. Fleming, was the best, and now may be relied on as an excellent keeper. He also sent Muscats of Alexandria and Tokays; and although it was not named, it seemed to say as much as that the Tokay keeps better than the Muscat. Mr. Forbes, gardener to the Duke of Bedford, sent the best bloomed Black Hamburgs I ever saw, and also a bunch of them which ripened this year, with large, green, fleshy leaves, but unfortunately they were received too late in the day to come in for competition, no doubt through delays by the railroad people. Twenty kinds of beautiful dessert *Apples*, and all true to name; a great treat now-a-days; and some first-rate collections of *Salad herbs*, complete the lists of things displayed.

The *Salad herbs* deserve to be enumerated. Mr. Burns, gardener to Earl Stanhope, was most successful. He had Beet, Celery, Radishes, Corn-salad, Endive (Curled and Batavian), Cress, Mustard, American Cress, Chicory (blanched), Water-cresses, Tarragon, young Onions, Chervil, and Burnet. Mr. Fleming, gardener to the Duke of Sutherland, had nearly the same.

From our garden was a collection of similar herbs, comprising two varieties of Chicory; Italian Corn-salad (*Mache d'Italie*), the best of the varieties of this plant; two French varieties of Celery, three indifferent specimens of Beet; three Sorrels, of which the best was a French kind called Belleville Sorrel (*Oscille de Belleville*), Chervil, Onions, and one or two other trivial things.

D. BEATON.

THE AURICULA.

(Continued from page 324.)

PROPERTIES OF A GOOD AURICULA.

1. The stem should be from five to eight inches high, and should be strong enough to bear the truss upright without any artificial support.
2. The footstalks of each flower should be so long as to allow room for each flower to expand individually, so as not to cover any other flower in the truss.
3. There should be a guard-leaf under the entire truss, to set off, by its green colour, the colour of the flowers (this is not indispensable).
4. The flower, or pip, should be round, large, with each petal of equal size, smooth at the edge, stout, and perfectly even or flat.

5. The centre of the flower, or tube, should not exceed one-fourth of the diameter of the pip; the anthers, or thrum, should all be even, a little raised above the petals.

6. The eye surrounding the centre should be pure white, without blemish, quite circular and distinct.

7. The ground colour: this part forms a circle between the eye and the outer edge, and the richer and darker it is the better the flower will be. This ground colour should never break through the outer circle to the edge.

8. The outer circle is the margin, and should be either of a clear green, clear grey, or clear white; and this part, in every petal, in every pip, should be of the same colour according to its class.

9th and last. The plant should be strong, and healthy, and the foliage broad and plentiful, so as to cover the soil.

The above are the properties the florists have agreed to constitute a first-rate Auricula; and though there is no doubt such an assemblage of qualities are desirable, and are now and then seen complete in all parts, yet, I think, great allowance should be made at exhibitions, and the prizes given to flowers that most approximate to the properties, and a slight defect in any one property over-looked, provided the whole contour or form, or, as the French happily express it, the *coup d'œil*, is as near perfection as possible.

DISEASES.—Unhappily, this beautiful flower is subject to a disease which is a kind of gangrene or cancer. It makes its appearance on the root-stem, underneath the soil. The indications of its presence are, the leaves flag, and water does not restore them; afterwards they turn yellow, and have a sickly appearance; it then either droops on one side, or the canker strikes quite through the stem, spreads upwards, and the plant dies; but if taken in time it may be saved. Take the plant out of the pot, and cut off with an unsparing hand all the cankered part till sound flesh appears; then anoint the cut part with chalk, re-pot in fresh compost, and place the plant or plants in a shady place, under a hand-light, till fresh roots are made, and the plant recovers its colour and health, and it is saved from a premature death. Should the whole collection have appearances of disease, then the general management is wrong, and there is nothing for it but an entire new potting in fresh compost, with plenty of drainage, and half-an-inch of charcoal between it and the soil. This must be done let the time of year be when it may, for a month's delay might carry off the whole stock.

INSECTS.—Worms and snails I have already mentioned; but sometimes the red spider and green fly make their appearance; the former after long-continued dry weather in summer, and the latter in early spring, upon the flower-buds, just before they begin to expand. The red spider must be got rid of by washing every leaf, on both sides, with a soft sponge dipped in water impregnated with sulphur; and the green fly by two or three gentle smokings of tobacco, the frames to be kept close for twelve hours after smoking; or, if there are but a few, they may be picked off on a camel-hair pencil, and crushed to death.

I have now gone through the entire course of culture for this charming spring flower, and shall conclude with a list of the best kinds, selected from various sources, both printed and written, as well as from my own notes and observations:—

GREEN EDGED.

Ashton's <i>Commodore Napier</i>	Dickson's <i>Duke of Wellington</i>
" <i>Prince of Wales</i>	" <i>Matilde</i>
Barlow's <i>King</i>	Faulkner's <i>Ne Plus Ultra</i>
Booth's <i>Freedom</i>	Hepworth's <i>Robin Hood</i>
Beeston's <i>Apollo</i>	Headley's <i>King James</i>
Crowshaw's <i>Lord Brougham</i>	Heath's <i>Emerald</i>

Leigh's <i>Col. Taylor</i>
Lightbody's <i>Star of Bethlehem</i>
" <i>Lord Lyndoch</i>
Ollier's <i>Lady Ann Wilbraham</i>
Page's <i>Champion</i>
Pearson's <i>Badajos</i>

Polhill's <i>Highland Laddie</i>
" <i>Standard of England</i>
Waterhouse's <i>Shakespeare</i>
Smith's <i>Britannia</i>
Warris's <i>Blucher</i>
Wild's <i>Highland Lass</i>
Yates Morris' <i>Green Hero</i>

GREY EDGED.

Atcherley's <i>Alpine Shepherdess</i>
Barlow's <i>Earl of Wilton</i>
" <i>Morning Star</i>
Buckley's <i>Surprise</i>
Chapman's <i>Sophie</i>
Cheetham's <i>Lancashire Hero</i>
Dean's <i>Regulator</i>
Fletcher's <i>Ne plus Ultra</i>
" <i>Commerce</i>

Grime's <i>Privateer</i>
Headley's <i>Stapleford Hero</i>
Hey's <i>Lovely Ann</i>
Jackson's <i>General Morilla</i>
Page's <i>Waterloo</i>
Sykes' <i>Complete</i>
Waterhouse's <i>Conqueror of Europe</i>
Warris's <i>Union</i>

WHITE EDGED.

Ashton's <i>Bonny Lass</i>
Buckley's <i>Miss Ann</i>
Cheetham's <i>Countess of Wilton</i>
Clegg's <i>Crucifix</i>
Chilcott's <i>Brilliant</i>
Campbell's <i>Robert Burns</i>
Heap's <i>Smiling Beauty</i>
Hepworth's <i>True Briton</i>

Hughes' <i>Pillar of Beauty</i>
Lee's <i>Bright Venus</i>
Lightbody's <i>Fair Maid</i>
Pott's <i>Regulator</i>
Sumerscale's <i>Catherina</i>
Taylor's <i>Favorite</i>
" <i>Incomparable</i>
Townson's <i>Lady Duncan</i>

SELFS.

Berry's <i>Lord Pimate</i>
" <i>Lord Lee</i>
Bradshaw's <i>Tidy</i>
Barker's <i>Nonsuch</i>
Chadwick's <i>Lady Franklin</i>
Clegg's <i>Blue Bonnet</i>
Dickson's <i>Apollo</i>
Gorton's <i>Goldfinch</i>
" <i>Stadtholder</i>
Headley's <i>Royal Purple</i>
Kenyon's <i>Freedom</i>

Kaye's <i>Jupiter</i>
Lightbody's <i>Admrl. of the Blue</i>
Macfarlane's <i>Earl of Fife</i>
Martin's <i>Eclipse</i>
Netherwood's <i>Othello</i>
Parker's <i>Metropolitan</i>
Redman's <i>Metropolitan</i>
Smith's <i>Mrs. Smith</i>
Sturrock's <i>Mrs. Sturrock</i>
Whitaker's <i>True Blue</i>
Wormersley's <i>Desdemona</i>

ALPINES.

Crompton's <i>Blue Bang Up</i>
" <i>Oldham Hero</i>
Captain Fraser
<i>King of the Alps</i>
Mellor's <i>Jenny Lind</i> (new)
Partridge's <i>Village Maid</i>

Queen <i>Victoria</i>
Willison's <i>Hannah</i>
" <i>Dan O'Connell</i>
" <i>Climax</i>
" <i>King</i>
" <i>Princess Royal</i>
T. APPLEBY.

PRESERVATIVE WALLS.

(Continued from page 306.)

LIST OF PLANTS SUITABLE TO PLANT AGAINST THEM.

Abelia floribunda (Many-flowered Abelia).—A free, early-flowering plant, with rosy-purple blossoms, something like a Fuchsia. The flowers are tubular, with a wide-spreading limb, and are very handsome. This is a genus of half-hardy shrubs, from Mexico and China. There are three more species, namely, *A. rupestris*, with pink and white flowers; *A. triflora*, pale red; and *A. uniflora*, white; but the first species is by far the handsomest. Peat and loam is the compost that suits them best.

Abutilon striatum (Striped Abutilon).—Though this plant is a native of the Brazils, and rather soft wooded, I have known it to bear the severity of moderate winters totally unprotected. It is a fast grower, and requires plenty of room; flowers most of the summer months, and is very showy when in blossom.

Acacia affinis (Related Acacia).—Many of the species of this beautiful genus will live against a wall of this kind, but this one is the hardiest of all. There is a plant of it at the end of the Camellia House, at the Pine Apple-place Nursery, that has stood four winters unprotected. I shall name a few others, that with a slight

protection of a covering of canvass would live and flower satisfactorily:—*A. armata*, *A. celsa*, *A. dealbata*, *A. dolabriforme*, *A. grandis*, *A. sophora*, *A. verticillata*.

Aloysia citriodora (Lemon-scented Aloysia).—Though the flowers of this plant are not showy nor bright coloured, nor the leaves particularly handsome, yet the pleasant odour the latter give forth when touched, renders it an universal favourite. It is, therefore, a desirable plant for the Preservatory.

Amorpha glabra (Smooth Amorpha).—This belongs to a genus of shrubs that are very little known, which is rather remarkable, as they all produce flowers of the much esteemed colours, blue and purple, and have leaves that are of a pleasing form, and bright green. *A. herbacea*, *A. Lewisii*, *A. microphylla*, and *A. nana*, are all desirable plants to place against this wall to fill up the places between quick growing and lofty shrubs, so that every part of the wall may be covered down to the soil.

Anopterus glandulosus (Gland-bearing Anopterus).—A rather new plant from Van Dieman's Land, but is supposed to be nearly hardy. The leaves are arranged in a fern-like fashion, and are very pretty.

Arbutus (The Strawberry-tree).—There are some species of this beautiful genus that are not quite hardy, but yet, on account of their fine evergreen foliage, are desirable and worthy of cultivation, and the Preservatory Wall is just the place for them, provided they are not too closely pruned. Their names are *A. Canariensis*, *A. densiflora*, *A. laurifolia*, *A. serratifolia*, and *A. speciosa*; *A. procera*, and *A. andrachne*, are hardy in the southern parts of Britain, but north of Birmingham scarcely so; and, therefore, require the protection of a wall beyond that line northwards.

Arctostaphylos longifolius (Long-leaved Bear-berry), *A. nitida* (shining-leaved), and *A. pungens*, are all handsome foliaged, half-hardy, evergreen shrubs, with shining leaves. The last is a dwarf, and may be planted between the others to fill up vacant spaces.

Aster.—The shrubby Asters, or Star-flowers of the Cape and New Holland, are not much cultivated now in greenhouses, but many of them against a sheltered wall would be very ornamental, and there would regain their popularity. Many of them have blue flowers, and are very ornamental. The following are the best:—*A. angustifolius*, *A. erubescens*, *A. liratus*, *A. myrsinioides*, *A. reflexus*, *A. sericeus*, and *A. villosus*.

Azalea indica alba, and other varieties. There are a sufficient number of hybrids of these fine flowering plants to cover a wall a hundred yards long, and a magnificent sight they would be when in flower. The white one is the hardiest. I saw a raised bed, in October last, about ten feet diameter, filled with it, in a garden at Acton, near London, and the gardener said they had been planted there for three years, and had had no protection excepting a covering over the roots of dried fern leaves in winter. The plants were about two to three feet high, and were more bushy, and had finer foliage than I ever saw them have in pots. A selection of the different colours, one of each, would be sufficient for a wall of moderate extent. No doubt, the new species introduced by Mr. Fortune, from China, would thrive best in such a situation, as also would the old species, *Azalea sinensis*.

Banksia.—This is an assemblage of shrubs from New Holland, with noble foliage, almost banished from our greenhouses on account of their not flowering till they are old and large. I judge, if Preservatory Walls become more common, they will become favourite objects to plant there, and would then grow and flower freely, especially if grown in poor sandy peat soil. The following are the most ornamental:—*B. coccinea*, *B. grandis*, *B. ilicifolia*, *B. latifolia*, *B. marcescens*, *B. solandra*, and *B. speciosa*.

Beaufortia decussata (Cross-leaved Beaufortia).—A fine scarlet-flowering, tall-growing shrub, hardy enough to bear several degrees of frost; flowers freely when old, but rather shy when grown in pots.

Benthamia fragifera (Strawberry-fruited B.).—In Devonshire this tree has produced its large, deep red, handsome fruit abundantly against the walls of a house. I saw the fruit once, some two or three years ago, on the tables of the Horticultural Society, in Regent-street, and thought them very handsome, and tempting to the palate; but Dr. Lindley stated they were not eatable. The flowers are yellowish-red, and tolerably handsome. These circumstances point out this as a desirable plant for the walls in question.

Berberis aristata, *B. buxifolia*, *B. macrophylla*, *B. nervosa*, *B. inermis*, and *B. trifoliata*, are all desirable shrubs, with evergreen foliage and yellow flowers. Since the Dictionary was published, two beautiful new species have been imported, which are both admirably adapted to plant against a wall. They are named *B. Darwinii*, almost, but not quite, an evergreen, with numerous golden-orange-coloured blossoms springing from the axils of the leaves, and *B. Nepaulensis*, which has leaves nearly eighteen inches long and one-and-a-half broad, deeply cut at the edges, and of a pleasing milky-green colour. The flowers of this latter species are produced at the ends of the shoots in clusters of four or five spikes, and are of a deep yellow colour.

T. APPLEBY.

(To be continued.)

PREPARING THE GROUND FOR SPRING CROPS.

NOTWITHSTANDING the mildness of the weather, we fear the ensuing seed-time will be anything but a pleasant one. Saturated as the ground has been with wet, and probably may continue to be, the benefits it usually derives from a period of rest have been much curtailed; and no doubt, in certain cases, a positive evil inflicted. But the season is fast approaching in which something must be done, almost despite the weather. Crops that require sowing in early spring will want the ground in some measure prepared for them beforehand. Usually, what is wanted for Onions, Carrots, &c., is either ridged or rough digged early in winter, and, perhaps, once or more during the frost-fertilising season, and finally about a month or less before sowing-time; the last digging may be less deep than the previous ones, if the weather, &c., do not promise to be of a kind to mellow it down. Now the past winter, up to the time I write (the last week in January), hardly deserves the name of one, being more like a prolonged autumn, so that the conditions necessary to fertilise, as well as pulverise the ground, have been almost totally withheld; a different course must, therefore, be pursued than is usual in seasons of an opposite kind.

Soils of an adhesive nature, with that peculiar texture which a short exposure to atmospheric influence tends rather to increase their tenacity than otherwise, must not be treated the same as those soils which mellow down quickly after an exposure of a few days; the better plan with the former will be to let alone the digging until the sowing has to be performed, and then to do both at once, as it will be in a better condition to rake down and afford a good bed for the seed, than it would be if left to the vicissitudes of the elements for a short time only. Observe, I do not mean to assert that sharp nipping frost or drying winds, followed by other changes, would not produce a better state of tillage than the hasty mode of digging compressed ground, and sowing it the same day; but then, what chances

have we this season of getting our ground into the healthy condition which requires but little judgment to pronounce the most proper state to receive seeds? Much, of course, depends on circumstances, as well as the state of the weather during the ensuing six weeks. If it should be severe, *i. e.*, with sharp cutting frosts and dry winds, the ground then would derive all the benefit necessary to ensure what in some countries is called "a good season," which means a fine mellow surface; but as none of us are able to foretell the coming weather, despite all the weather prophets' assistance, we must take our measures according to what seems most probable, instead of what we most wish.

Where ground has lain a great part of winter in that compressed state which a heavy treading in autumn induces, it had better remain in that condition still, if we are likely to be visited with a continuation of those heavy rains so common of late, because, the firmer the ground, the less chance there is of it holding water in an undue quantity. This is easily ascertained by any one who just digs up a spadeful of soil on a loose open space, and then on a hard one; the former, in wet weather, is loaded like a sponge; the latter is like the sponge subjected to a pressure. Now, though we do not pretend to say that rain water, even in deluging quantities, does not convey something that is useful to the earth, yet we are far from thinking its benefits are felt by land in that loose open state of tillage which digged ground presents; whereas the firm ground, by receiving the same amount of rain on its surface, allows it to percolate through, otherwise run off, and, doubtless, it leaves some of its fertilising properties in the soil it filters through, and probably leaves most where the strainer is closest; that it is so in the light ground, must be evident to every one.

Now, we have said enough to show that on some obstinate soils a little exposure is worse than none at all; and that such ground, which circumstances have hitherto prevented being dug during winter, had better be delayed until sowing time; but then, more mellow soils which had been ridged, or rough digged during autumn, had better now be slightly pointed over, in order to expose the surface as much to the elements as possible. A nice frosty morning is the best time to do this work, otherwise when the ground is tolerably dry, with winds, &c.; and although it may be improper to dig deep, yet the ground, if necessary, may be stirred the full depth of the spade, provided that the top of all remains at the top again, or nearly so; this is important when there seems not sufficient time to mellow the under stratum before the ground is wanted for cropping, but the period required for that purpose differs so much in various soils, that no general rules can be laid down for guidance in the matter. One thing we may enforce on the young horticulturist—that all soils are injured by being worked when in a very wet condition, that is, when charged with water to excess; but this is not always the case with the compressed ground we have been speaking of, because, if needs be, that may be dug up when a spade cannot be put in soils of a lighter and more friable nature; but which, by lying open, are exposed and compelled to drink in every passing shower; but remember, these stiff soils must be dug and sown, or planted, at the same time, otherwise the rains, if there be any, will render the treading and working on such a soil a matter of impossibility; and it is possible that the sowing season may partake of the general character of the winter.

I have not said anything about the manure proper for crops that are wanted to be sown early, because usually such manuring is done in autumn; but when that has been omitted, no delay must take place now; and even in the ground we have been advising to leave

undug till sowing-time, the dung, and other matters, ought to be in readiness to dig in them; and whatever may be said about the utility of dung being administered in a fresh, unfermented, or undecayed state, it is better that both processes be pretty far advanced at this season. In autumn, a rougher article might, perhaps, do as well; but now the little time left before it be called on to furnish those juices necessary to the well-being of plants it is destined to nourish, renders it imperative that it should be ripe, or nearly so, for that purpose.

Onions, being a gross-feeding crop, require a good proportion of dung; but they are better when it has been given in liberal quantities, the year before, to some crop that has not exhausted it too much. We have been in the habit, for many years, of sowing our Onions on ground that the early Celery had come off, and we do not see any better place, when other things are taken into consideration as well. *Carrots*, and similar *root-crops*, ought to have the ground trenched about eighteen inches, or more, early in autumn; and what dung or other enriching matter was put in ought to be in the bottom, or from the bottom to the middle of the trench, so that none of it will be so near the surface as to entice the roots of such plants as Carrots, Beet, &c., to fork and divide, on purpose to remain amongst such rich food, which they unquestionably will if it exist in any quantity near the top. Another condition necessary to ensure good *Carrots* is to have the ground free from those hard, impenetrable lumps which resist the downward growth of roots. It must, likewise, be free from *wireworm*, if possible, and for that reason, had better not be where any of the Cabbage tribe had occupied the preceeding year. This latter evil may be got over by a dressing of gas-water, or the lime that has been used there. Common lime, unless used with a very liberal hand, seems unable to accomplish the destruction of this pest; and we are by no means advocates for large quantities of it being used where Carrots are grown, for its presence is at variance with the nature of the soil where the root luxuriates in the greatest perfection.

Many things will now require to be seen to in various ways. Warm, dry borders, that have not received a crop, may be planted with *Early Potatoes*, or, at least, a quantity of these may be planted crossways. *Radishes* may be sown against a south wall; and on some favoured, warm spot sow a little *Lettuce* and *Cauliflower* seed. The protection of glass, we fear, is a luxury that cannot well be afforded such crops; but when any lights are at liberty, let them be used in some way or other. Sow *Peas*, and plant *Beans*, for the after crops; and watch carefully that the slug does not destroy those coming up or advancing apace. *Sea-kale* will now force with less trouble than heretofore, that it need not be covered up so long before the time it is wanted to come into use; but it will still require heat. Take up all *Parsnips* that are yet in the ground, and other roots; and on all favourable occasions *wheel out dung*, &c., on land that may require it. See to *Cucumbers*, and other tender objects in the forcing department, so that no lack of heat gives them a check; and turn and prepare dung, &c., for more *Hotbeds*, which make up when wanted, at the same time sowing *Melons* and *Cucumbers* occasionally, to succeed those already in, or, it may be, make up a deficiency, or, what is also not to be forgotten, to furnish a less-favoured neighbour with a pot or two of plants, if required.

J. ROBSON.

BORDERS AND THEIR ARRANGEMENTS.

THE time is now fast approaching for being busy in digging and planting, altering or re-arranging our borders; and of course this will be found the more readily effected by those who took the hint Mr. Beaton gave out in one of

his excellent papers last year, advising friends to label or number their plants in the borders as they come into flower, &c., for the sake of knowing where they are at the proper time to re-arrange them in the borders. This is very important, and what we at all times attend to.

Now, last March, we re-arranged a favourite little border in the following manner:—It is a border situated by the side, and the whole length of a south terrace-walk. The walk is twelve feet wide, with a grass verge, one foot-and-a-half wide, separating the walk from the border. The border is three feet-and-a-half wide, and at the foot of a brick-wall, eleven feet high, which is covered with flowering shrubs, and other climbing plants. This wall and border are from seventy to eighty yards in length, and have been crowded with flowers for the last twenty years, and at most seasons of the year something or other could be seen in flower either in the border, or on the wall, or both. The border was filled many years ago with hardy border-plants, in three rows, about two-feet-and-a-half from plant to plant in the row, and none were placed there that grew very tall. That is, we had nothing that was more than about from two feet to two-feet-and-a-half in height, at the most; of course, these were in the back row. The next row was still dwarfer, from one foot to one-and-a-half high, and the front row principally of bulbous kinds. The three rows of plants were always kept in compact snug bunches, and precisely alternate with each other in the rows, that is, in the quincunx-form, and all labelled. In the summer, abundance of other bedding plants were introduced as intermediates to the permanent arrangements; something of all sorts, so as to be as various as a regular mixed border could well be, but still avoiding any that were tall, so as not to obstruct the light to the wall. As I said before, it was thought well to alter the preceding arrangement, and in the month of March we set about it, taking up every plant, and working up the border well, adding a little well-rotted manure; not that we needed much in this way, as the border gets well manured by a top-dressing of old hotbed manure every winter. This serves as a protection to many of the plants upon the wall. Comfort is comfort to a man when he is going out of a cold winter's evening, to put on a great coat and an extra cravat round his neck, and so it is with these plants under our wall, to have a good top coat of this good old manure packed up well round their collars, or the base of their stems, and over their roots too.

Having the border ready to receive the plants, a line was set down at one foot-and-a-half from the wall, length-ways, and the plants selected and planted three feet apart in the row. This done, the line was brought forward one foot, and the second row of dwarfer kinds planted, both rows in front of the line, of course, and precisely alternate with each other, and thus confining the border to two rows of permanent plants. These were all labelled, as usual, and very nice the border looked, and so it does at this time. In this front row we have introduced, every now and then, a bunch of *Crocus*, indeed, all the bulbs at certain distances, for the purpose of introducing the summer plants of a certain kind and colour in the same line, in the place of those bulbs, as will be seen hereafter. The reason why we planted our permanent plants three feet apart in the row, and confined them to two rows only, is to be the more regular and complete when introducing a summer plant between every two permanent plants, from end to end of the border, without injuring these; and should there be any chance of this, the watchful eye can soon see, and soon cut away anything that is intruding.

Any number of *kinds* of plants may be employed as the summer intermediates in this still mixed border; but this is not our plan. We use three colours, and intend so to do as yet. The back row of summer plants, from end to end, is of the *Cælestina ageratoides*, light blue; the front row of summer plants is of *Scarlet Geraniums*, of the Tom Thumb variety, except where bulbs stand as the permanent plants; here a Yellow *Calceolaria*, *Calceolaria rugosa*, is let in with care with a small trowel, so as not to injure or disturb the bulbs. I must add, that I never saw a mixed border to please better than this did last season, and so said many others who saw it. Of course no label is required to the summer plants.

I have omitted to say, that there is a bed of the Mexican

Tiger flower, *Tigridia pavonia*, in the centre of this long border, and it does not seem at all out of place. This bed is about four yards long. The *Tigridias* are taken up every three years, and the bed well worked-up, and a little new soil added, such as comes from the old melon bed, and a little sand with it. The bed being ready to plant, a drill is chopped with the spade six or seven inches deep, and the strongest bulbs planted as thick as they can well stand by each other in the drill; this done, the drill is filled up, and so on in three drills length-ways of the border; and nothing can possibly flower more freely, or do better. They are taken up about the middle of March, when their time is to be replanted. The bed is top-dressed, and more carefully in severe winters.

The hardy herbaceous perennial plants that are planted in this border are not very choice, the situation being very hot at times; indeed, too hot for many others of our choicer kinds to do well; therefore, we have to suit the plants to the border. We have, in most cases, only one specimen of a kind; in others, two of a kind. When two of one kind are planted, they are placed at certain distances apart, so as to look uniform. The following is a list of the permanent hardy plants, in the order they stand in the border:—

BACK ROW.	FRONT ROW.
<i>Dracocephalum Virginicum.</i>	<i>Primula auricula, var. hortensis.</i>
<i>Dianthus Garnerianus.</i>	" <i>vulgaris pleno alba.</i>
<i>Erigeron Philadelphicus.</i>	" " <i>lilacina.</i>
<i>Chrysocoma Linosyris.</i>	<i>Potentilla Tongueii.</i>
<i>Geranium Ibricum.</i>	<i>Pulmonaria Virginica.</i>
" <i>striatum.</i>	" <i>officinalis.</i>
" <i>sylvaticum.</i>	<i>Panacratium Illyricum.</i>
" <i>Phœum.</i>	<i>Smilacina bifolia.</i>
<i>Geum Chilense.</i>	<i>Pentstemon spicatum, or proceras.</i>
" <i>grandiflora.</i>	<i>Scilla præcox.</i>
<i>Inula glandulosa.</i>	<i>Saxifraga umbrosa.</i>
<i>Rudbeckia hirta.</i>	<i>Silene Shafitii.</i>
<i>Melittis grandiflora.</i>	<i>Sempervivum montanum.</i>
<i>Mimulus cardinalis superba.</i>	<i>Sedum Aizoon.</i>
<i>Melissa grandiflora.</i>	<i>Veronica pallida.</i>
<i>Phlox suaveolens.</i>	" <i>gentianoides.</i>
" <i>maculata.</i>	<i>Omphalodes verna.</i>
" <i>odorata.</i>	<i>Enothera prostrata.</i>
" <i>speciosissimum rubrum.</i>	<i>Cheiranthus alpinus.</i>
" <i>delicata.</i>	<i>Crocus vernus.</i>
<i>Polemonium cœruleum.</i>	<i>Iris pumila.</i>
<i>Achillea rosea, or asplenifolia.</i>	<i>Erythronium dens-canis.</i>
<i>Anemone japonica.</i>	<i>Eranthis hyemalis.</i>
<i>Aster lævis.</i>	<i>Helleborus niger.</i>
" <i>ameloides.</i>	<i>Francoa appendicula.</i>
<i>Astrantia maxima.</i>	<i>Fritillaria alba.</i>
<i>Betonica grandiflora.</i>	<i>Geranium sanguineum.</i>
<i>Centaurea montana.</i>	<i>Galanthus nivalis pleno.</i>
<i>Crucianella stylosa.</i>	<i>Lithospermum purpureocœruleum.</i>
<i>Campanula persicifolia pleno alba.</i>	<i>Muscari racemosum.</i>
" " <i>rubra.</i>	" <i>monstrosum.</i>
" <i>azurea.</i>	<i>Orobus vernus.</i>
" <i>grandis.</i>	<i>Prunella Pensylvanica.</i>
<i>Symphytum Bohemicum.</i>	<i>Narcissus bulbocodium.</i>
<i>Solidago (a pretty dwarf kind).</i>	" <i>minor.</i>
<i>Veronica maritima.</i>	" <i>ajax.</i>
" <i>candida.</i>	<i>Dielytra formosa.</i>
" <i>lacineata.</i>	<i>Corydalis bulbosa.</i>
" <i>elegans.</i>	<i>Anemone sylvestris.</i>
<i>Lychnis viscaria.</i>	" <i>Apennina.</i>
<i>Malva lateritia.</i>	<i>Arabis Alpina grandiflora.</i>
<i>Trollius Asiaticus.</i>	" <i>variegata.</i>
	<i>Aubrietia purpurea.</i>
	<i>Campanula Carpatica.</i>
	" <i>pumila.</i>
	" <i>pulla.</i>

The two ends of this border, for three or four yards, are shaded and gloomy, suiting the *Primulas*, the *Anemone Apennina*, *Saxifraga*, *Corydalis*, and *Dielytra* in the front row, and the *Trollius* and some others in the back row. Of course, any plant that is a spreader at root is taken up and replanted yearly, so as to keep snug compact bunches.

The following is a list of the plants trained against the wall:—

<i>Cydonia Japonica.</i>
" <i>alba.</i>
<i>Jasminum officinale.</i>
" <i>revolutum.</i>
" <i>nudiflorum.</i>
<i>Edwardsia grandiflora, a very fine plant.</i>
<i>Spiræa Lindleyana.</i>
<i>Forsythia viridissima.</i>
<i>Clianthus puniceus, turned out here last spring, and is now very full of bloom. Whether we can save it here has to be proved.</i>
<i>Garrya elliptica.</i>

Hydrangea Japonica.
Pœonia Moutan; a fine plant.
Clematis azurea grandiflora.
 " *florida*.
 " " *pleno*.
 " " *bicolor*.
 " *montana*.
 " *viticella pleno*.
 " or *Atragyne Siberica*.
Caprifolium flexuosum.
 " *gratum*.
Escallonia rubra.
 " *macrantha*.
Passiflora cœrulea.
Arundinaria falcata; a fine plant.
Buddleia Lindleyana; this flowers finely here.
Ceanothus lævigatus.
Statice Dickensonii.
Myrtus communis; narrow and broad-leaved varieties do well here.
Veronica Lindleyana; a fine plant, with abundance of bloom at this time.
 " *speciosa*; one of the tenderest upon the wall.
Abutilon striatum; this has been out some years, and flowers tolerably well every year. Growing very rampantly it requires more room than we can spare it.
Deutzia scabra.
Weigela rosea.
Siphocampylos bicolor; this dies down to the ground every year, and rises again the year following, like a willow, four or five feet in height, and flowers very freely.
Pittosporum Tobira; this flowers very beautifully here.
Aloysia citriodora; this is cut down yearly to the ground, and puts up again very vigorously.
Daphne Dauphinii; this is a very fine specimen, and is a most desirable plant to have under a wall.
Robinia hispida.
Chimonanthus fragrans.
Wistaria sinensis, often called *Wistaria consequana*. This is a very handsome specimen, only allowed to occupy a breadth of three or four feet of the upper part of the wall. All the lower shoots have always been cut away, making room for other plants to be trained under its branches upon the wall, which extend about ninety-five feet in length.
Punica granatum.
Olea Europæa.
Lycium Europæum.

ROSES.—We have nothing in this way in particular; at any rate, nothing new. A nice plant of the old single *Macartney Rosa bracteata* does well, and flowers freely, and continues in succession for some time. *Maria Leonada*, *Scarlet Greville*, *Jaune Desprez*, *La Marque*, *Ruga*, *Devonensis*, *Highclere Seedling*, the double *White Moss*, *Yellow Banksian*, and a few others.

FUCHSIAS.—*Riccartonii* is about the best of all for a wall out-of-doors, being the strongest grower, one of the hardiest, a profuse bloomer, and the best colour. The old *virgata* is still here, and is one of the next best for out-door growth. *Gracilis multiflora* is a pretty free-blooming plant. The old *globosa* is here too. *Youngii grandiflora* also does well here. Among the newer sorts which have found their way here of late years, *Eppsi*, *Exoniensis*, *Cavatina*, the *Silver Globe*, *Rose Quintle*, and *Bianca*. The last-mentioned is the best as a free grower and a free bloomer.—T. WEAVER, *Gardener to the Warden of Winchester College*.

DEALERS AS JUDGES.

THE following letter is written to you as expressing the sentiments of many of your subscribers and readers; and though it is conceived that you may not deem it advisable to publish it, they are not without hope that you may be willing to consider carefully both sides of each question referred to; upon which it has been thought by some that the tone of your paper has lately assumed a character not likely to increase the number of your friends. I purpose, in the present letter, to touch upon the question of having dealers among the judges at poultry shows, and, as connected therewith, your remarks on the recent Metropolitan Poultry Show.

[So far from being unwilling to publish this letter, we do so most readily, for our only object is the attainment of truth. It is the invariable consequence of criticism, even though having only that object, that it gives pain to some one; and it must often occur that the person pained is not sufficiently master of himself to avoid resenting as personal an enquiry which, being only to establish a general principle, he should rather aid in carrying forward to a conclusion. Persons so pained, and acting thus mistakenly, are not well qualified to judge of the tone of the criticism;

and from their judgment we appeal, and fearlessly appeal, to the opinion of every unbiassed reader; and we shall, indeed, be surprised, if any one sentence can be pointed out, for which we are responsible, that is either excessively severe, or in any degree discourteous.]

First, then, as to dealers being judges. It is urged, that they must feel a bias in favour of specimens with which, in the course of their dealings, they have become acquainted, and, therefore, that the public must object to dealers being judges. Now I would observe, that no charge is made, or even hinted at, against any dealer on the score of bias; and, therefore, it is clear that your remarks are only directed against the possibility of evil; and I would venture to assert that bias of a different kind has not only been suspected, but has been openly complained of, in the case of some judges, who were not dealers. I will not enter into a discussion whether Mr. Sturgeon, Mr. Punchard, and many other gentlemen, are not as much dealers, in one sense, as Mr. Baily, but this I broadly assert, that a system was becoming established which has, thanks to Mr. Dixon and others, been broken through, which threatened much more serious detriment to poultry shows than any other drawback, viz., to consider the types of Messrs. Sturgeon's and Mr. Punchard's specimens as the standards of perfection, irrespective of any defects they might present.

This contracted view injured the public taste; it detracted also from the value that ought to be placed on the decision of parties considered competent to be judges, and, until this last Birmingham exhibition, threatened to undermine the wish of the public to be taught fairly and honestly, by the decision of competent parties, what were fair standards of excellence. Believe me, Sir, the objection was much more strongly felt, that if A B C D E or F happened to be judges, Sturgeon was sure to have a host of prizes because each of the judges had formed their notions of excellence solely from their intimate acquaintance with Mr. S.'s birds, specimens of which were the pride of their yards, they themselves being on intimate terms of friendship with Mr. Sturgeon; the objection, I say, was, and is much more strongly felt against this system, than against the one you condemn. I am in intimate association with many of the Sturgeonites, and loud and deep were their complaints that Mr. S. did not, at the last show, as before, gain all the prizes; and yet I have made enquiry among unbiassed persons who have seen all the best birds in England, and I cannot doubt the decisions at Birmingham were strictly fair. In fact, the determination shown to make an example of all persons whose specimens had been trimmed has been of the greatest service.

[It is quite true that we have never brought any charge against Mr. Baily, nor against any other dealer, of being guilty of dishonesty in his decision, and that for the best of all reasons—we have never had any proof of such dishonesty brought to our notice. When such proof is produced, whoever the dishonest decision shall be in favour of will find no favouritism in our criticism. That bias can exist—nay, does exist—among judges, is admitted by our correspondent; and then comes the question—Are not dealers even more liable than others to be so influenced? Whether the form of Mr. Sturgeon's Shanghaes are superior to any hitherto exhibited, is a matter of opinion; but, probably, our correspondent will not dissent from the judges' award at Birmingham, which gave to Mr. Sturgeon's adult birds the first prize. The determination to disqualify all birds which have been trimmed—that is, had feathers plucked from them to render any part of them more in accordance with any desired form—has our unqualified approbation. A bird should be shown perfectly un mutilated; and any one who trims his birds has no more just title to a prize than the florist who cuts out offending petals. The skill is shewn in growing them of a right form; not in clipping them to it.]

And now, as to the dealer question. I think you cannot seriously believe that any dealer can influence two or three gentlemen of education and character in any improper way. Such a supposition is monstrous; and I can only imagine a person believing such a thing, who would himself, if he had the opportunity, endeavour to use his influence unfairly. On the other hand, the presence of a man like

Mr. Baily, of acknowledged experience and skill, is of the greatest value, as his judgment must be generally very accurate connected with this matter. It has not been without pain, that your readers have observed your admission into your paper of many queries, &c., from "Q-in-a-Corner," and others, who, from their utter inability to prove one tittle of what they insinuate, only show the soreness under which, from some cause or other, they labour.

[Our correspondent is quite right in supposing that we do not intend to maintain so monstrous a position, as that either a dealer, or any one else, could influence two or three gentlemen so far as to induce them to do an act of flagrant wrong; but our correspondent forgets that no such point is in dispute. The simple question is—Is not a dealer in poultry more liable to be biassed than any other man as a judge at a poultry show? Cases must arise in which there is a division of opinion; and if one of the pens of birds in suspense have been sold by himself, is not that likely to influence his judgment rather towards them? We own that we think it would. We know that such, too, is the public opinion; and we know that at no other exhibition would a dealer be appointed who had sold any of the competing stock to the competitors, any more than Mr. Clarke would be continued as judge at Newmarket if ever he became a dealer in horses over whose success he had to sit in judgment. We agree, without the slightest reserve, in what is stated as to Mr. Baily's skill and experience; but we also know that there are many amateurs competent to decide on the merits of poultry, and, therefore, we do not think it a wise course to weaken the confidence of exhibitors by needlessly retaining him as a judge. Thus to express our opinion has been, and is, highly painful. From Mr. Baily we have received many courtesies; we have not the slightest unkind feeling towards him; and we know of no man to whom we would sooner apply for aid and advice in any mercantile transaction connected with poultry; but this must not turn us aside from advocating what we know to be sound in principle. With regard to the questions of "Q-in-a-Corner," the insinuations they contain must fall to the ground, because he declines to have his name revealed. We do not blame him for this, because no man can find pleasure in a paper war; and we take some blame to ourselves for having inserted the questions, even after "Q" had assented to our suggestion, that mere insinuations ought not to appear.]

I now turn to the other subject I proposed. And here I would remark, that if you could only give your readers a less perfect prize list of the Metropolitan Show than was given by the *Times* and other papers last *Tuesday morning week*, it is a pity you troubled yourself to do so at all. Although the prize list had been published a week, your list varies from it in the first sixteen classes in more than a dozen particulars, of name, place, &c.; and you have omitted all the commendations throughout, and also all report of prizes in classes 47, 48, 49, 50. In another part of your paper, you tell the public that Mr. Sturgeon, Mr. Punchard, and Mr. Peck, were missed; and, perhaps, on this account it is that the public miss all particular mention of any of the specimens in class 11, 12, 13, 14, 15, and yet I have heard, from competent judges, that some of the specimens in class 15 equalled or exceeded anything ever shown at Birmingham. The public will believe, say what you will, that the person who wrote the article in that week's number has had some influence over him, for a style of criticism differing from that in every other English newspaper on the same subject.

[All these charges and inuendos admit of a ready answer. We did not publish the prize list as it appeared in the daily papers, because we were told they were incorrect. The list we did publish was furnished to us direct from the Committee of the Metropolitan Show. If there was any omission, the blame does not attach to ourselves. We never, intentionally, publish notices of the "commendations" at any of the Shows; our object being only to notice where the best birds are to be found. We hope, notwithstanding our correspondent's contrary conviction, that the public will believe us when we state, that we selected the gentleman who obliged us with the report on the Metropolitan Show, not only because he perfectly understands the

subject, but because he has always been the advocate of Mr. Baily, and is no extreme admirer of Shanghaes. We think, on cool consideration, that our correspondent will not dissent from our opinion, that such birds as Mr. Peck's, Mr. Punchard's, and Mr. Sturgeon's, must be desirable at any Exhibition.]

On another point, also, I think the public will differ with you, *viz.*, as to the sale by auction. What rational objection can there be to this? If I do not wish to sell my specimens at all, I have only to put on a really prohibitory price, and my object is gained. If, however, I am willing to sell, if I can get what I conceive would make it worth my while to part with any specimens, I have only to affix that price, and the public will decide whether they will buy or not. Surely this is far better than the miserable trickery and squabbling that has heretofore disgraced the Birmingham exhibition, as to the claiming of pens. It is equally fair for all; the other system was not.—ONE OF YOUR SUBSCRIBERS.

[That there is any trickery at Birmingham in selling the poultry we were not before aware; and we are quite sure that the public ought to be warned against it if there is. The objections to the sale by auction appear to be, that so far as the public are concerned, they ought to be allowed to buy at such price as the vendor is willing to sell for; and it is a new feature to make such exhibitions a means of making purchasers pay the highest obtainable price. Then, as regards the vendors; it is satisfactory to them if they obtain a higher sum than they originally named; but it must be very injurious to them, when, instead of their own prices in pounds, they could scarcely obtain an offer of as many shillings, as, we are told, was the case at the sale alluded to.]

BRITISH FUNGI.

In the foregoing papers on that most extensive order of plants, the Fungi, it has been my aim, as far as space would allow me in these columns, to give a rather popular view of the interest, and also the practical advantage, to be derived by a more close and attentive study of this too much despised and neglected branch of the vegetable kingdom. In doing this, I have not brought one point in connection with their good qualities forward with overpowering colours, while the less favourable have been left almost invisible in the background; nor have I allowed theory to bring forward statements which cannot be carried out in practice. My object has been rather to explain as simply, and plainly as possible, the interest that might be derived by amateurs, as well as by botanists and others, by devoting a portion of their time to the study of these plants. I have also endeavoured to point out those which may be looked upon as man's greatest enemies, as parasites and poisons, and also those of most value to him as an article of diet, and serviceable in the arts and in medicine, hoping, that in so doing, I may have provided a temporary guide to those who may have more time and opportunity for more perseveringly and rigidly pursuing their investigations of the subject. That Fungi are objects of interest generally, I find all who have studied them most willing to confess; while, of course, those who have not studied them cannot be considered competent judges. They are more interesting, because they flourish at a period when our flowering plants are departing to their grave; and they are found in localities the most sullen and dreary; many producing their brilliant colours and phosphorescent light in dark and unhealthy regions, where but little besides them could support existence.

I shall here mention one species, previously omitted, but which I consider worthy of especial notice. It is *Peziza coccinea*, and, in beauty of form and richness of colour, scarcely to be rivalled. It is cup-shaped; the interior surface is of the purest carmine, and the outer surface white and downy. This Fungus is not uncommon in spring, growing on dead sticks, and generally surrounded by green moss, which adds to its striking appearance. It is found in woods and hedges, and if collected carefully with the sticks on which it grows, it may be kept in a Fernery, or Wardian case, where it will thrive and have a beautiful effect, if the temperature is not too great. I have found it abundant about Basingstoke.

That it is difficult to preserve Fungi is quite a mistaken notion, as, in addition to what I have already said about drying the higher groups, as directed in the English Flora, the parasitic species are generally produced on the leaves or bark of other plants, and may be collected and dried in thousands, it being only necessary to dry the leaves or bark to preserve the Fungi.

With respect to esculent species, if what I have already said has not been sufficient to prove their value, I fear any farther recommendation will be useless. The fact, however, of their attaining perfection so speedily, being so abundant in species, and also in their power of propagation, will increase their value as an article of diet, either in their natural or cultivated state, as large quantities may be collected and preserved in a short time; and it is much to be regretted that delicious food should be condemned on account of the mismanagement, or gross carelessness, of a few ignorant persons. The animal instinct is often a safer guide to follow than reason, which is frequently allured from the right path by various theories; and who will not believe this, to his regret, when he sees *Boletus edulis* so devoured by rabbits, that he may search in vain to obtain a dish unblemished? But is not this mark to be relied upon by the collector with more confidence than Her Majesty's letters patent stamped on many articles presented to the public? I stated, that I should recommend no parties to commence collecting Esculent Fungi without the assistance of a botanical friend, to which I ought to add, or a person familiar with them; for Esculent Fungi, I believe, may be recognised from their less-wholesome neighbours, in the same way as a parent knows her child amongst a multitude, from constant and attentive observation, which establishes an impression on the mind and in the eye not easily forgotten. A few years since, we had a deplorable case of poisoning by the common Mushroom reported in most of the public journals; and this year it is backed-up in one of our contemporaries with a ridiculing attack on Dr. Badham, attributing to him an instinct which teaches him those Fungi that are, and those that are not, poisonous. I beg to state that I possess no instinct peculiar to the brute creation which teaches me which are good and which are bad; and I imagine that what has taught me has taught Dr. Badham also; namely, a confidence in the opinion and experience of my predecessors; an eye open for observation; and a firm determination not to be governed by the prejudiced opinion of others.—F. YORKE BROCAS.

POULTRY SHOWS.

DONCASTER.—We took occasion, in a recent publication, to enumerate the different towns in Yorkshire in which poultry shows had been established. We have now to make the addition of Doncaster, in which place the first exhibition of poultry was held on the 21st of January, under the patronage of the Mayor and Corporation of the borough, and of a long list of neighbouring noblemen and gentlemen. The Show took place in the spacious corn market, a building as much adapted for the purpose as any we have yet seen. The pens exceeded 400 in number, and were arranged in four parallel rows down the whole length of the market. Ample space was thus afforded for inspecting the specimens exhibited, and the pens themselves were particularly light and neat. The whole arrangements did much credit to the committee of management, and their indefatigable secretary, Mr. Henry Moore; and, in this respect, those who have the conduct of much older shows might take a hint or two with advantage from their brethren at Doncaster.

The exhibition itself was, upon the whole, very successful for a first attempt, more especially as it was confined to the district of twenty miles round Doncaster, a restriction which no doubt excluded many good birds, and which the committee determined to remove in future years. As this was but a commencement, it would be unfair to criticise too minutely; but, commencing with the first classes in the catalogue, we may say, that in the different varieties of *Hamburgs* some good pens were shown, although we think the Doncaster amateurs might impart new blood with advantage in these classes from their brethren in the vicinities

of Bingley and Keighley. The *Game* classes were indisputably the gems of the exhibition. There was scarcely an indifferent, not to say a bad, bird among them; and a gentleman who had visited the recent Metropolitan Exhibition assured us, that the *Game* fowls shown there did not approach in quality to the collection at Doncaster. The judges added their testimony to the excellency of these classes by awarding that the premium prize (Class 40) for the best pen of fowls in the yard, should be equally divided between pens 169 and 185, both containing *Game* fowls. Some good *Dorkings* were shown, but other pens would not have been much missed if they had been left at home. There were also some good *Spanish*, but nothing of first-rate excellence. The same remarks apply to the *Shanghaes*, with the exception of some very fine specimens exhibited by Mr. Travis, of York, who, being one of the judges, would not, of course, compete for prizes. Our Doncaster friends will, no doubt, before their next show, take a leaf or two from the book of Mr. Travis. The *Polish* fowls were the worst classes in the exhibition. The *Bantams* were numerous and pretty, without affording any pens of peculiar merit.

The *Geese* were only moderate; the *Ducks* very good. A pair of white ducks, in pen 355, were, we think, the largest we ever saw. The *Turkeys* also were good. Where the general arrangements were so good there is little to suggest by way of amendment; but we may, perhaps, be allowed to recommend the Doncaster committee in future to require two, if not three, hens, to be shown in each pen. We will only add a hearty and very confident hope, that their future exhibitions may answer their own best expectations (as we are sure this must have done); and they will soon become dangerous, although we hope friendly, rivals to their older neighbours.

We add the list of prizes awarded.

- CLASS 10.—*Golden-spangled Hamburg Cock and Hen, of any age.*
103. First prize, Mr. E. Auckland, Red Lion Hotel, Doncaster. Hatched June 20, 1852.
106. Second prize, Mr. W. B. Tate, Doncaster.
- CLASS 11.—*Golden-spangled Hamburg Cock and Pullet, Chickens of 1852.*
109. First prize, Mr. J. Brooke, Rossington. Hatched April, 1852.
- CLASS 12.—*Silver-spangled Hamburg Cock and Hen, of any age.*
121. First prize, Rev. A. Fullerton, Thrybergh.
118. Second prize, Mr. J. Brooke, Rossington. Cock one year old, Hen four months.
- CLASS 13.—*Silver-spangled Hamburg Cock and Pullet, Chickens of 1852.*
131. First prize, Mr. W. B. Tate, Doncaster.
- CLASS 14.—*Chitteprat Cock and Hen, of any age.*
136. First prize, William Hall, Esq., Laughton.
139. Second prize, Mr. George W. Morris, Doncaster. Hatched June, 1851.
- CLASS 15.—*Chitteprat Cock and Pullet, Chickens of 1852.*
144. First prize, B. H. Brooksbank, Esq., Tickhill.
- CLASS 16.—*Game Cock and Hen, (White and Piles) of any age.*
148. First prize, Hall and Co., Doncaster. Hatched 1851.
151. Second prize, William Mellowes, Esq., Carburton.
- CLASS 17.—*Game Cock and Hen (Black-breasted or other Reds) of any age.*
169. First prize, William Mellowes, Esq., Carburton, and equal with 185, in Class 40.
167. Second prize, H. Eddison, Esq., Gateford.
- CLASS 18.—*Game Cock and Hen (Blacks and Brassy-winged) of any age.*
178. First prize, Mr. E. Frith, Turner Wood. Two years and eight months old, price £5 5s.
180. Second prize, H. Eddison, Esq., Gateford.
- CLASS 19.—*Game Cock and Hen (Duckwings and other Greys) of any age.*
185. First prize, H. Eddison, Esq., Gateford, and equal with 169, in Class 40.
184. Second prize, Mr. E. Frith, Turner Wood. One year and seven months old, price £5 5s.
- CLASS 20.—*Dorking Cock and Hen of any age.*
186. First prize, Sir T. W. White, Wallingwells. Hatched in 1851.
187. Second prize, R. J. Bentley, Esq., Fittingley Park.
- CLASS 21.—*Dorking Cock and Pullet, Chickens of 1852.*
217. First prize, Mr. Thomas Hudson, Market-place, Wakefield. Hatched April 15, 1852.
- CLASS 22.—*Spanish Cock and Hen, of any age.*
223. First prize, Mr. T. Kendall, 9, Banks Terrace, Goole.
220. Second prize, R. J. Bentley, Esq., Fittingley Park.

CLASS 23.—*Spanish Cock and Pullet, Chickens of 1852.*

238. First prize, Mrs. Wm. Workman, Adwick-le-Street. Hatched April 27, 1852.

CLASS 25.—*Coloured Shanghae (Cochin-China) Cock and Hen, of any age.*

242. First prize, Mrs. Batty, Ackworth Grove. Cock hatched May 30, 1852, and Hen, August, 1851.

247. Second prize, Mr. George Hatfield, Doncaster.

CLASS 27.—*Coloured Shanghae (Cochin-China) Cock and Pullet, Chickens of 1852.*

270. First prize, Mr. Robert Carr, Wortley Hall. Hatched January 26, 1852.

CLASS 28.—*Polish Cock and Hen, of any age.*

279. First prize, John Hall, Esq., Kiveton Park.

280. Second prize, R. Raywood, Esq., The Poplars, Darfield.

CLASS 29.—*Polish Cock and Pullet, Chickens of 1852.*

283. First prize, John Cordeux, Esq., Keresford House, Barnsley.

CLASS 30.—*Cock and Hen of any other breed.*

290. First prize, B. H. Brooksbank, Esq., Tickhill.

295. Second prize, Mr. E. Coulman, Plains House, Levels. Malay Cock and Hen.

CLASS 31.—*Golden-laced Bantam Cock and Hen, of any age.*

317. First prize, J. Fullerton, Esq., Thrybergh Park.

299. Second prize, John Hartop, Esq., Barmbrough Hall.

CLASS 32.—*Silver-laced Bantam Cock and Hen, of any age.*

319. First prize, John Hartop, Esq., Barmbrough Hall.

CLASS 33.—*Bluck Bantam Cock and Hen, of any age.*

322. First prize, John Hartop, Esq., Barmbrough Hall.

323. Second prize, T. Smith, Esq., Wood Head House, near Barnsley. Hatched in 1850.

CLASS 34.—*White Bantam Cock and Hen, of any age.*

325. Second prize, John Hall, Esq., Kiveton Park.

CLASS 35.—*Gander and Goose.*

334. First prize, W. F. Hoyle, Esq., Ferham House, Rotherham. Hatched in 1852.

333. Second prize, Mr. G. M. Moate, Fenwick. Gander two years, and Goose one year old.

CLASS 36.—*Drake and Duck (White Aylesbury).*

341. First prize, B. H. Brooksbank, Esq., Tickhill.

339. Second prize, Mr. J. Brooke, Rossington. Hatched July 7, 1852.

CLASS 37.—*Drake and Duck (Rouen).*

349. First prize, B. H. Brooksbank, Esq., Tickhill.

350. Second prize, B. H. Brooksbank, Esq., Tickhill.

CLASS 38.—*Drake and Duck of any other variety.*

355. First prize, Mr. G. Trimmingham, Marr Grange. Hatched June, 1852.

365. Second prize, William Chadwick, Esq., Arksey. (Black East Indian Ducks.)

CLASS 39.—*Turkey Cock and Hen.*

376. First prize, H. L. Maw, Esq., Tetley.

374. Second prize, R. J. Bentley, Esq., Fittingley Park.

CLASS 40.—*For the best pair of Fowls in the yard, of any class or breed. Nos. 169, and 185, equal.*

EXTRA STOCK.

394. First prize, Master Henry Moore, Angola Rabbit, fawn-coloured Doe, one year and four months old.

405. Second prize, William Hall Esq., Laughton. One Cock and six Hens.

415. First prize, Mr. G. D. Thorpe, Scawthorpe Farm. One Game Cockerel and three Pullets, hatched April 30, 1852.

419. First prize, John Waring, Esq., Haworth Hall, near Rotherham. South American Cock and Hen, hatched in 1851.

421. First prize, John Hartop, Esq., Barmbrough Hall. Archangel Pigeons.

HONITON.—The First Exhibition of the Honiton Association for the Improvement of Domestic Poultry was held in that town on Wednesday, January 12th, 1853, in a spacious building, 140 feet long, erected by Mr. Ward, of the Clarence Hotel, for the manufacture of railway carriages.

179 pens of poultry and pigeons were entered for competition, and arranged around the building in baskets similar to those recommended by our correspondents, Messrs. Jessop.

From the quantity of poultry bred in the district, and sent weekly to the London market, a good show was anticipated, but the result must have far surpassed the most sanguine expectations of its promoters. Following the order of the catalogue, the *Spanish* first claims our attention; and, notwithstanding Devonshire is noted for its breed of black fowl, there called "Minorcas," we were glad to observe several pens of superior Spanish, having all the characteristics of that breed fully developed.

The *Dorking* class was the best in the exhibition, and the whole received the high commendation of the judges. Several of the pens contained first-rate specimens; the birds

in some of them were not so well matched as might be wished, but this future exhibitions will correct.

The most attractive class, however, was the *Shanghae*, which contained many beautiful specimens. The first prize was awarded to birds which were highly commended at the late Birmingham Show.

The *Malays* were better represented than at many recent exhibitions. The prize medal birds at Birmingham taking only a second prize.

The *Game* fowls occupied only four pens, and were not the best specimens of this beautiful variety of poultry.

In the *Hamburgh* class, a pen of Silver-spangled birds was pronounced by the judges the most perfect in the exhibition. The Silver-pencilled were very good. The cock and one hen, in No. 73, belonging to E. S. Drewe, Esq., were nearly perfect, but the other hen deprived the pen of all chance of a prize.

Several splendid specimens of Golden Polands, and an excellent pen of Black Polands, attracted universal attention.

The *Cross Breed* and *Barn Door Fowl* mustered in great force. The first prize was awarded to a good pen of Cuckoo fowls; and the second prize, and the prize for chickens, to birds very much resembling the *Sussex* breed.

Bantams were indifferent. *Geese* few, but good.

The *Ducks* were highly meritorious, and received especial commendation. The *Aylesbury ducks*, which obtained the first prize, were particularly fine.

Turkeys were excellent. The cock in No. 138, belonging to R. T. Head, Esq., Exeter, a very superior bird.

A large variety of *Pigeons* were shown, and some of them very splendid birds; but from the greater part being crowded in small pens the effect was destroyed, and the judges had great difficulty in awarding prizes.

The Judges were the Rev. J. C. Fisher, Heavitree, near Exeter, and G. J. Andrews, Esq., Dorchester.

The following prizes were awarded:—

SPANISH.—7. First prize, Miss Stamp, Honiton. 3. Second prize, Mrs. Devenish, Honiton. *Spanish Chicken of 1852.*—9. Prize, E. Stamp, Esq., Honiton.

DORKING.—18. First prize, T. Blandford, Esq., Orchard Portman, near Taunton. 20. Second prize, J. F. Pearse, Esq., Whimple, near Exeter. *Dorking Chicken of 1852.*—27. Prize, W. Pope, Esq., Symondsburly. 23. Highly commended, J. H. Townsend, Esq., Ashfield, Honiton. 29. Commended, J. F. Pearse, Esq., Whimple. The Judges considered the whole Dorking Class generally meritorious.

SHANGHAE.—33. First Prize, R. T. Head, Esq., Exeter. 31. Second prize, S. Devenish, Esq., Honiton. 37. Commended, Mr. Channing, Heavitree, near Exeter. *Shanghae Chicken of 1852.*—40. Prize, Mr. Brown, Shute, near Axminster. 44. Prize, R. T. Head, Esq., Exeter. 53. Highly commended, Mr. Channing, Heavitree. 45. Commended, Clifford Shirreff, Esq., Pinhoe, near Exeter. 47. Commended, Dr. Rogers, Honiton.

MALAY.—55. First prize, H. Adney, Esq., Lympstone. 60. Second prize, C. Ballance, Esq., Taunton. 56. Commended, H. Adney, Esq., Lympstone.

GAME.—63, 64. First and Second prizes, Mr. Ward, Honiton.

GOLDEN HAMBURGH.—No First prize awarded. 68. Second prize for Golden-Pencilled, S. Devenish, Esq., Honiton. 69. Second prize for Golden-Spangled, Rev. H. K. Venn, Honiton.

SILVER HAMBURGH.—77. First prize for Silver-Spangled, Rev. H. K. Venn, Honiton. 74. Second prize for Silver-Pencilled, J. P. Hine, Esq., Thickthorne, near Ilminster.

POLAND.—First prize for Golden Poland, Mr. Hoskins, St. David's, Exeter. 83. First prize for Black Poland, J. P. Hine, Esq., Thickthorne.

CROSS BREED, OR BARN-DOOR FOWL.—98. First prize, Mr. Lewis, Honiton. 85. Second prize, Mrs. Troake, Hemoick. *Cross Breed, or Barn-Door Chicken of 1852.*—99. Prize, Mrs. Troake, Hemoick.

BANTAMS.—No First prize awarded. 107. Second prize, C. Ballance, Esq., Taunton. 114. Second prize, Mr. Pile, Honiton.

GESE.—115. First prize, Dr. Jerrard, Honiton. 117. Second prize, C. Shirreff, Esq., Pinhoe.

DUCKS.—121. First prize, Mr. Brown, Shute. 125. Second prize, T. Blandford, Esq., Orchard Portman. The Judges considered the class highly meritorious.

TURKEYS.—135. First prize, H. Adney, Esq., Lympstone. 137. Second prize, Mrs. Griffin, Monkton, near Honiton.

GUINEA FOWL.—No competition. No First prize awarded. 140. Second prize, Mrs. Venn, Payhembury.

PIGEONS.—143. Prize for Carriers, Mr. Downton, Honiton. 161. Prize for Tumblers, Mr. Channing, Heavitree. 163. Prize for Fantails, Mr. Tucker, Honiton. 166. Prize for Nuns, H. Adney, Esq., Lympstone.

DISEASES OF POULTRY.

INFLAMMATION OF THE EGG-PASSAGE.

IN reference to the interesting case mentioned at page 213, two letters have been received, one in reply to my

queries as to whether the inflammatory action might not have been occasioned by the over production of eggs, &c., and the other from Mr. Shepperd, which appeared at page 312. It appears that the hen was an extraordinary layer, and that the disease was not caused by her being prevented from sitting, or by over-stimulating food.

With regard to Mr. Shepperd's letter, I must beg to state that I entirely differ from him; that such a structural disease, as a cartilaginous thickening of an internal organ, could be cured by placing the patient before the fire, is utterly opposed to all medical experience.

That one grain of calomel and one-twelfth of a grain of tartar emetic killed the hen, I also decline to believe; inasmuch, as I have repeatedly given those doses to hens laying soft eggs from inflammation of the oviduct, and in every case have had hard eggs laid on the second or third day after.

It is useless to talk of leaving diseases to nature as long as hens are kept in unnatural conditions; the natural position for a hen is to live in a warm climate, in the open air; to obtain her own natural food by moderate exercise; to lay only as many eggs as she can cover and sit; then diseases do not occur, and the animal dies of old age, or becoming decrepid is destroyed by a beast of prey.

I agree, however, with the writer, that "half the people who complain would get well without a physician," because they complain when nothing is the matter with them; but although I have paid very considerable attention to sick poultry, I have never yet seen a hen with hypochondriasis.

I may mention a circumstance which has just occurred in my own yard, in corroboration of what I have said so repeatedly respecting over feeding. My Grey Dorking pullets, hatched in May and June, have been laying very well since Christmas, some are now sitting, and will hatch before the end of January, they are fed most freely on barley, oats, meal, and rice. A few days since, I tried the experiment of giving them some greaves, and the result has been, that all the June pullets have been laying soft and imperfect eggs; some malformed, containing no yolk, others merely yolk, &c., and this morning I picked up one on the grass 13½ inches long, tapering to each end, quite soft, without any yolk; thus proving that a very considerable portion of the oviduct was in a state of unnatural irritation, and which I have no doubt I can remedy immediately, by giving each one a teaspoonful of castor-oil mixed up with some dry barley-meal, in which form it is taken readily. —W. B. TEGETMEIER, *Tottenham*.

PEA-FOWL.

IN the present day, when fowls of various kinds are fetching high prices, and much care is required to rear them, it appears singular that the Peacock family are not more considered. It is true, they pick the early buds in the garden, but that mischief might be guarded against at less expense, perhaps, than is required for the erection of poultry-houses. I am quite sure they would repay the possessor; they require no attention, and are not voracious, very independent in their habits, choosing their roosting places in the highest trees, from whence the winter snows, winds, and rain, never chases them. A fine pair of these regal birds was presented to myself, with instructions not to take any further trouble about them, beyond keeping the young from the cock bird for the first fortnight after hatching, after which time they would be able to take care of themselves. In the month of June the hen bird introduced a fine little hearty family of five to my admiring gaze. Strictly following the caution given, I enclosed the mother and her brood, feeding them with the pheasant ant and eggs. Confinement was evidently distasteful to them, and at the end of the given time, when I released her, she hurried away with her young to the open field, in search of their natural food, insects and flies, bringing them home to their roosting place in the evening. From that moment all care on my part was at an end. The parent birds were quite tame when given to me, and I have kept them so by letting them feed out of my hand; the young birds became tame also, coming to my call from any distance. Beyond

now and then throwing them bits of bread, and a small quantity of barley, I took no trouble to fatten them for the table; and the following spring two of the young birds, when killed, were in excellent condition, and were pronounced by all who partook of them to be high-flavoured and excellent, having the noble appearance of the turkey, with the high *gamey* flavour of the pheasant. This summer I have left the hen to enjoy her liberty with her young, and find that she is quite equal to take the entire management of her brood: carefully did she avoid the haunts of the older birds; and I shall, for the future, leave her to herself. Instinct directs her, and the Wisdom that provides for the safety of the meanest of his creatures has taught the mother how to secure her young. As a mother, the Peahen is far more interesting than the common fowl. She is so gentle, is never disturbed if you approach her young; there is none of the noisy clucking of the hen, no scratching, and no bustle; she is quiet and graceful in her movements, and an elegant appendage to the lawn. I wish I may be a means of inducing others to rear this beautiful and excellent bird.—JUNO.

VISITS TO SOME OF THE CHIEF POULTRY YARDS OF ENGLAND.—No. 5.

(PENZANCE.)

(Concluded from page 249.)

IN the adjoining parish of Gulval, there are several gentlemen who have given their attention to poultry, and are possessed of some valuable specimens of the different varieties. Now, it should be a matter of rejoicing to poultry-keepers, that taste and opinion differ so much in this as in other pursuits; were we all to assign the palm of merit to Cochin-China, Spanish, or any other single race, the charm of variety would fail us, and probably, also, we should experience far less pleasure and interest when we thus lost the opportunity of comparing the conflicting merits of the numerous candidates for our good opinion. Thus, Mr. Grenfell has fortunately selected the Hamburgs for his especial favourites, and possesses capital birds of both the Silver-pencilled and Silver-spangled varieties. The latter appear, perhaps, rather more robust, as to form, but as regards laying, and other points, he considers the merits of the two very much on a par. (The term *spangled*, as opposed to *pencilled*, implies, that instead of the light longitudinal markings of the latter, the spangled bird has the extremity of each feather, more especially on the wings and tail, *barred* or *dotted* with black.) In every case, a full rose-comb, terminating in a point, must be well-developed, and this, with the white or yellow of the ground contrasting clearly with its darker tints, is always requisite for a perfect specimen. These are excellent layers, and readily raised. No fowl, be it observed, possesses a larger number of synonyms—Moonies, Bolton Greys, Moss fowls, Chitteprats, and many others, belong to them. Mr. Grenfell possesses also some very good Game fowls, which were sent to him from Norfolk, but these are necessarily kept at a distant farm. Their indomitable spirit compels their banishment from the abodes of all other kinds of poultry. Mr. Thomas Roscoe, who in former days superintended the famous breed of Game fowls at Knowsley, no mean authority, tells us, that "I have known them frequently attack men, dogs, calves, pigs, turkeys, and geese; and a single bird has killed seven of its opponents in one day, while fighting in our trial mains at Knowsley."

At Gulval vicarage, the Rev. W. W. Wingfield has given his attention principally to Cochin-Chinas, regarding them as the race most likely to be ultimately kept with profit by the cottager and farmer of this district. For this purpose, he considers it essential to have compact, robust birds, adhering closely in this respect to the opinion of THE COTTAGE GARDENER, that a perfect specimen of the Cochin-China breed "should have no more legginess than a Dorking." The birds that here appeared to answer this description were still young, but of good shape and colour. We noticed also some very promising cinnamon and buff pullets, from the collection of Mr. Blee. The cock from which the greater number of Mr. Wingfield's chickens have been bred, is very light buff, with a rich golden hackle, very short on

his legs, and with a happy absence of tail, but being a very late bird of last season he has not yet attained his full size.

Under the guardianship of two Punchard hens, nineteen Cochinchina chickens were desporting themselves, the two mothers sharing their maternal duties, and attending indiscriminately to their wants. We were informed that these birds, pullets of last year, laid their first egg on the same day; and having sat twice during the present season, also commenced that process both on the same day, and were alike regular in the production of their chicks in due course of time.

When the various members of the poultry-yard were called together for their dinner, certain queer, little, round, white balls, like animated powder-puffs, eagerly answered the summons. Our attention was at once rivetted, and so unlike were they to anything that had as yet passed in review before us, that we had at once to confess our ignorance, and ask for information. *Silk fowls from Calcutta* were these; and at once their white, woolly coat, and black skin, pictured to our minds the well-got-up Hindoo mendicant, who swept the crossing in Fleet-street, with clothing and complexion both of corresponding hue to what was now before us.

Ducks, also, of various kinds, here met our view, the progeny of those who, in 1851, were successful in their respective classes at Birmingham. The bulky Rouen, with its rich grey tints, came side-by-side with its chattering companion, the Call Duck, the beauty of whose plumage in a mature state is rarely exceeded. The black Labrador and white Aylesbury are also fitly represented.

Among the Pigeons, our attention was specially given to a pair of very large copper-coloured Italian Runts; they are still young, but their parents attained the unusual size, together, of 3½ lbs. Mr. Wingfield seems sanguine as to the profitable substitution of such birds for the present inferior pigeons which are reared as occupants for our pies, or to be transfixed by our spits.

A pair of Trumpeters, which were thought worthy of sitting for their portraits to illustrate the "*Dovecote and Aviary*," the pure bred Blue-rock (*Columbia livia*), and the white Fantails or Shakers, are also visible; these all inhabit little apartments contrived for them at the top of the different fowl houses.

At Pendrea, J. Bedford, Esq. has not only a large collection of fowls, but on his ponds below the shrubbery are to be found many, both of the useful as well as ornamental, specimens of the duck tribe. First, however, let us describe the fowls. On entering the lodge, we find ourselves in the presence of a tiny white Bantam cock, in proud possession of ten chickens of his race, who, being in early days deprived of their mother's care, are now on the point of attaining maturity under the sole charge and responsibility of their well-pleased father. Although the present taste has declared in favour of the fawn and buff-coloured Cochinchinas, one cannot fail of admiring the rich tints of our old Punchards (a race once well described as of a Bloomerish character), who appear here to great advantage; the run of the lawn and the shelter of its beautiful evergreens being liberally allowed them.

Speckled Dorkings of high cast and pretention, silver Hamburgs, and white Silkies swell our list; while of Bantams, Chinese, Siberian, black, white, and yellow, gratify the spectator whose taste may run in their direction. Mr. Bedford has some young chicken bred between the Cochinchina and Dorking, the result will, at any rate, be curious; for the Cochinchinas that were in vogue some three or four years since were probably indebted to such a union for the fifth claw that so often made its unwelcome appearance in birds that would otherwise have rewarded our experiments.

By passing through the flower garden, which seems to defy the ravages of the late inclement weather, we stand by the ponds, overhung by lofty elms, and bounded by the dark smooth foliage of masses of Rhododendron. Araucarias, Deodars, with a remarkably fine specimen of *Cryptomeria japonica*, and the genus *pinus* in great diversity, would silently delay us for their inspection. But noisily do the Call Ducks summon us in their direction—with them are the pale-billed Aylesbury of most satisfactory bulk and consistency, and the black Labrador with its resplendent tissue of *golden-black*, if painters will allow us such a word.

But a word on these *Buenos Ayrean* strangers, for by various names are they designated; and their common one, the Labrador duck, is the name of a country which probably has the very worst claim to them. They are magnificent alive; excellent, too, when roasted; and in charity, let us strongly advise any of our readers who may possess a suitable piece of water, to gratify their eye and palate at the same time, by selecting them as its occupant; remembering, however, to *kill them from the pond*, as the term goes, never shutting them up, but supplying them liberally with food at large.

But these are *minutiae* that our columns have no space for, so let us proceed with our catalogue, which brings some Wild Ducks next to our notice. According to many writers on Natural History, these would claim honourable mention at our hands, as the original parent of that most respectable individual, "the farm-yard duck;" but this may well be doubted, and, strange as it may sound to some, we are probably indebted to eastern countries for this popular companion to sage and onions.

Dun-birds, Golden-eyed-divers, and a bereaved widgeon, are the remaining members of this happily-located family, whose peaceful retreat, however, has been at times disturbed by the presence of a most unwelcome visitor, an otter; who, finding an exclusive fish diet did not agree with him, took the unusual course of varying it with wild-fowl. The learned in such matters tell us, that it is a very rare occurrence to find an otter under any circumstances preferring flesh to fish, but here trout with eels, their favourite food, were both abundant. However it may be elsewhere, we find that instances of such forays of otters are by no means uncommon in this part of Cornwall; there are those who remember an otter being killed in the middle of Chapel-street, Penzance. The individual, however, or one of those, who perpetrated these atrocities at Pendrea, at length fell a victim to his appetite, and was found to weigh no less than fourteen pounds.

Imperfect, however, would be any description of these feathered inhabitants of Gulval, which did not specify some very handsome Pea-fowl belonging to William Bolitho, Esq., at Chyandour; we miss, however, a fine white bird, which we remember to have seen there some time since. These Pea-fowl, old and young, formed a very attractive pen at the Penzance Exhibition, where their companions, the Guinea-fowl, were also present. Mr. Bolitho has some golden Hamburgs, and a numerous family of Silk-fowls.

There are several others, however, in this parish, who are desirous of achieving a triumph; of these, Mr. Branwell has some good Cochinchina chickens, also Mr. Charles Richards, jun., while Mr. White has given his attention principally to the gold and silver Polands. There are, also, other neighbouring districts where similar endeavours have been made towards improving their poultry, but to enter into any particulars at present would demand space far beyond our present limits.

CROSS-BREEDING.

I WAS one of the very first of your correspondents to call attention to poultry as a chief delight and help of the cottage gardener, and I feel great pleasure in coming in again now with my little contribution when the subject has attracted so much notice.

The system which I have invariably pursued is one which holds, I believe, in the case of all the improving breeds of domestic animals. It is a remarkably cheap and plain system. I have adopted it ever since I commenced, and the gradual improvement of my stock has been a yearly source of pleasure and interest to me.

I began with the best fowls I could easily procure in the neighbourhood; these were mostly *silver pheasants*, so called. By procuring every year a good Dorking cock, I have gradually had half-bred, three-fourths, seven-eighths, fifteen-sixteenths Dorkings; but I have been so satisfied with my system, that every year two or three known good country hens have been among the *sub-introductæ* of the establishment.

But not to be behind the fashion, I have begun to transmute my Dorkings, as they now are, into Cochins, by the help of a fresh Cochinchina every year. I find my stock to have

become famous, and I am continually asked by my neighbours for eggs, cockerels, and fowls, either as gifts, or to sell, or, best of all, to exchange.

There is nothing very speculative or uncertain in the system; for I find that the short-horn blood amongst cattle has been chiefly procured among farmers by the same principle, viz., crossing the best individual country cows with the pure short-horn bull; following the same rule with their progeny and so on.* Indeed, I doubt if the short-horn itself be a strictly pure breed.

The English hunter, or carriage-horse, has been gradually brought to be what he is by the same proceeding of *gradually* improving the common breed of the former with a cross of pure blood. Indeed, it is now contended by Hamilton, Smith, and others, that the racer has been made what he is by crossing our native blood with foreign high-bred animals of ancient stocks.

On the other hand, I am afraid that the general practice of breeding exclusively pedigreed stock on both sides will not prove a very profitable pursuit; and I am, and always was, indeed, anxious to unite the most pleasure with the least loss in the schemes which I have laid down for my own following. I believe that it is hard to naturalise, at once, a foreign race of any kind of domestic animal. Acclimatization is a very difficult process, and the method above recommended, by giving each year a home-bred mother, has natural advantages not to be lost sight of. Somebody, however, must keep up the pure breeds; and, as a means of raising the order of the barn-door fowls of their neighbours, this attention to the choicest sorts is highly commendable in the rich.

There is also another great point in breeding—to have some good points of similarity between the parties to be crossed. A very singular phenomenon connected with the subject has been noted casually, and from time to time, although, from the difficulties of the subject, it has not yet been thoroughly investigated. In two words, then, *the first union appears to exert in the lower animals a certain abiding influence over the whole maternal life of the female*. Such being the case, it is easy to see that many failures, in attempting to improve fowls, may occur from not beginning with pullets. Nay, it has been suggested, that even a faint resemblance to allied races may be obtained; in this way, and by first mating a good pullet with a cock pheasant, it may be expected that her next family, though of barn-door origin, will retain some traces of the glories of the wild bird. This is the present opinion of highly scientific men. As regards the lowest classes of animals, the principle may be carried on and improved; and it opens a wide field of observation to the amateur breeder.

VIBCYOR.†

BEEES IN BOX-HIVES.

As you solicit returns from apiarians respecting their success in the past season, if you think the following worth insertion it is cheerfully submitted to your readers. Premising that this district is in close proximity to the moor, about two miles distant, where heath is in abundance, also being on the border of the South Hams, which is considered the garden of Devonshire, as that is of England, your readers may fairly conclude we carry on our apiaries under very favourable circumstances.

In the first place, I would merely observe, that with us the wooden-boxes have not altogether answered as could have been wished for, although they did very well for summer use; in winter, in spite of every precaution in the way of ventilation, on the most approved principles, with bell-glass inserted in tin receivers, the combs became black and mildewed, and the bees severally suffered very considerably, or died. With the old straw-hives

* The following is from the Useful Knowledge Society's Work on Cattle, page 241, and is from the Rev. Mr. Berry's account of "Short Horns":—"A friend of mine had about twelve small, but nice, North Devon cows; with these he commenced, twenty years ago, breeding with the short-horn bull. He has since invariably used these bulls. With each succeeding cross the stock has rapidly improved in every essential; the only trace of the Devons I could perceive two years ago was a peculiar richness in colour. Here we have twenty years experiment, and continued improvement. I have known him sell heifers to jobbers for thirty guineas."

† We have written, but cannot find your full direction.—Ed. C. G.

this was by no means the case. Our attention, therefore, was turned to adopt some modification of both plans, so as to secure the advantages of both; and in this I think we have pretty well succeeded. Our box on this plan is of a square description, with under compartments of fourteen inches square, and seven deep, with the same amount of space over, in which are placed the bell-glasses, the opposite sides of the under part or store being made of reed, in layers, laid horizontally, as in the old straw-hives. The swarm that occupied this hive was placed there the 14th of June, 1851, and has this year produced the following amount of honey, leaving a store for winter:—Four bell-glasses placed on the 1st of July; on the 29th took off three weighing about 3½ lbs. each, leaving one which, at the present time (December), the bees have just begun to consume, and the stock is above 20 lbs. in weight. A stock in a wooden-box of the same form died, and another in an American form of wood-box, although having lived through the winter, has produced no honey in the glasses on the top, nor swarmed; and of four stocks in the old reed-hives, one only has swarmed. The whole of these, with the exception of the modified hive, being very light at the present time, and will consequently require to be frequently fed, when weather permits; the heaviest of them being under 20 lbs. I may merely add, that although I have been an ardent admirer of the wooden-box system, and have pursued experiments in testing their capabilities which have cost me many pounds, I have sorrowfully come to the conclusion, that to the cottager who is to make keeping bees a matter of *£. s. d.*, they will not pay, taking cost of box, vicissitudes of seasons, &c., into consideration; and although I lament that the system of keeping bees on the humane principle is not more carried out in this neighbourhood among the agricultural population, I can by no means, as far as my experience goes, recommend them to incur the expense of keeping bees in the modern wooden-boxes but for the purpose of instruction and amusement.

Although I obtained in the glasses of the American hive above referred to, 23 lbs. of pure honey, in a good season, about four years ago, I have not succeeded in taking anything like that amount in any season since that time, and I have been informed by apiarians, that they would not put a swarm in a wooden-box under any consideration.—EXONIENSIS, *Ashburton*.

TO CORRESPONDENTS.

. We request that no one will write to the departmental writers of THE COTTAGE GARDENER. It gives them unjustifiable trouble and expense. All communications should be addressed "To the Editor of the Cottage Gardener, 2, Amen Corner, Paternoster Row, London."

MILTONIA SPECTABILIS (*Amateur, Dublin*).—You say your *Miltonia* has two strong shoots from one of the old bulbs; and you ask if the connection between the young and old were cut through, without more disturbing the plant, would it induce growth in the old bulb? Of course it would; stopping has the same effect on *all plants*; but whether or no the old bulbs will be able to make another growth, depends on how the buds near their base stand. If these buds are alive they will certainly push; but if they are dead, the old bulb has no power to move, or to make a fresh bud. Young bulbs or shoots of orchids should not be cut off from the plant until the first growth is completed and ripe; but by taking a portion of the old plant off with a young shoot the separation may be done at any stage of the young growth; but the first plan is best and safest.

INDIGOFERA DECORA (*Ibid*).—You are now too late for this season. The end of October is the right time to prune this plant, and it ought to be pruned like a *Fuchsia*, and receive more than greenhouse heat all through the winter and on till May. This very beautiful plant, which will stand out of doors near London, ought to be in a forcing-house, such as they put *Roses* and *Lilacs*, &c., into, from November to April; then it will flower all the summer just as *Fuchsias* do. When a plant comes to full size, it may rest all the winter, but it is *perfectly impossible* to get a specimen of it from a young plant by summer growth. Some of the best of the Peruvian plants lately introduced are in the same predicament. They must be set to work just as other plants are going to rest.

BORONIA SERRULATA (*Ibid*).—See what Mr. Fish said at page 176 of our last volume. He gave the best directions for this tribe of any we know of. We might throw out some more hints about them, had you not overwhelmed us with so much writing at once.

FLOWER-GARDEN PLANTING (*C. M. D. and R. S. E.*).—We have received your ways of planting No. 3 plan, and shall notice them about the end of March, when we hope to have many more trials to record.

AZALEA SEEDS (*Something yet to learn*).—You may just as well try to stop the March winds, as expect any improvement from the seeds of

Chinese, or any other Azaleas gathered at random. Give them to some friend going to Australia.

ARBOR VITÆ SEEDS (*Ibid.*).—When you see the seed-pods begin to crack the seeds are ripe; this is generally in April. At whatever time the seed is ripe, that is the best time to sow it; and do so in loamy soil, in flat pans, and cover one-fourth-of-an-inch. Then place the pans in a cold frame, and look after them as you would after a pan of cauliflower seedlings.

HEATH CUTTINGS (*Ibid.*).—There is no composition for preserving the bottom of heath-cuttings, or any other cuttings, from decaying. Mr. Fish, in some of our former volumes, gave the best and newest directions for rooting heath cuttings; and the best of the old authors on cuttings is Cushing, who was once a propagator "in Lee's Nursery," and who could strike anything.

CHARACTERISTICS OF SILVER-PENCILLED HAMBURGS (*N. P.*).—The Silver-pencilled Hamburg cock should have a bright rose comb, erect and regular, carried well back to a point; head fine, with a short bill. His colour should be clear white; wings and tail alone excepted; the former should be regularly barred, a great test of purity; the latter full, with the sickle feathers of great length, and of rich metallic black. In a perfect specimen we would admit no appearance of white in the tail. But this is seldom attained. The hen displays the peculiarities of this variety, as to plumage, to a much greater degree than the male bird. Her hackle, and some portion of the lower part of the body—the less of the latter the better—is white; any stain, indeed, in her neck hackle would be fatal; the rest of her plumage, to the extremities of the tail, should be regularly pencilled, *i. e.*, each feather should be distinctly marked with at least four parallel bars of black, about one-sixth-of-an-inch in width; the extremities of the tail is often furnished by a somewhat broader band of the same colour. Any running of the colours one into another is objectionable, especially when they are so blended as to produce the appearance of what is commonly called the Silver-moss fowl, an appellation which bespeaks its origin. Both sexes should have clean, pale blue legs, and any appearance of feather on them at once disqualifies; their carriage is erect, and appearance emphatically neat.

SCARLET GERANIUMS (*Subscriber, Isle of Man*).—*Tom Thumbs*, *Superbs*, and *Emperors*, being potted from the borders as late as November, and kept almost dry in a room, the shoots are now green with very few leaves, and the puzzle is how to go on with them from the early part of February. It so happens, that we ourselves have some Geraniums in the same state, and others, that were not taken up from the borders till the 10th of January, are the same. We mean to water them; at least, keep the mould in the pots moist from this time, to encourage young roots to come. About the middle, or towards the end of March, we shall cut them all down to within a joint or two of the old wood, and make cuttings of every morsel we cut off. We have only a very dry greenhouse, and then the cuttings must take their chance. Some hundreds which we put in last September are now beginning to root nicely.

PRUNING IVY (*J. G.*).—The best time to trim Ivy is the moment it throws out breast-wood from the upright wood which clings to the wall. This breast-wood is what gives beauty to Ivy planted against trees and ruins; but when it is intended to secure brickwork from the weather, damp, &c., it must be kept constantly close to the wall, otherwise it is apt to ruin a wall by drawing water to it. If you have any of your Ivy hanging out from the wall, pray cut it in close early in April, and never allow it to come so again; by looking over Ivy once a month during the summer, and cutting back all breast-wood, and thinning the leaves where they are too thick, it will last a great many years, and keep the wall perfectly dry. September is the best time to put in cuttings of Ivy; but the truth is, you can plant cuttings of it all the year round, if you water them in dry, hot weather. February, and to the end of April, is not at all a bad time for planting the cuttings.

SOIL (*A Countryman*).—The soil you sent us will not grow any of the Rhododendron or Azalea tribes. It is very good, however, for almost any kind of trees and large shrubs, and to mix with poor land for corn crops.

MAGNOLIA GRANDIFLORA (*Ibid.*).—This will not grow from cuttings. If any of the branches are so low as to admit of layering you can grow as many plants of it as you have branches fit for layers. Lay them next April, as Mr. Beaton said lately, and next October twelve months you will have good rooted plants fit to cut from the mother plant. Even if they seem rooted enough at the end of twelve months, and you cut them off, you will lose time in the long run.

BLACK SHANGHAE.—"E. M. begs to inform "T. A." he is decidedly mistaken in his opinion as to there being no black Shanghae fowls in England, as E. M. has at the present moment a very fine one. Her eggs are very dark. E. M. received her black hen, with others of various plumage, a remembrance from her husband (last month), who is captain of an English clipper ship in the China trade. "T. A." says, "Imported is so commonly used with reference to China fowls, that it goes for nothing." He must also be aware there are exceptions to every rule, in consideration of which E. M. begs he will receive her intelligence as something to be credited."

GANGRENED FANCY GERANIUMS (*Troublesome*).—They have been under very favourable circumstances, but they die off between the young and the old wood, the parts either turning black, or shrivelling. We cannot conceive how that particular malady could appear under the circumstances, and we rather think that something bad at the roots has killed all the bottoms, although the symptoms did not appear till death entered the young parts. We have known geraniums to keep green at this season long after the roots were dead. If this is not the case with yours, you are better off than we venture to expect; at any rate, cut away all dead and decayed parts down to sound living wood at once, and try to raise fresh plants by cuttings of the tops which you take off.

WORK ON PIGEONS (*W. J. M.*).—We do not know of any good one.

BOTTOM-HEAT FOR CUTTINGS (*A Subscriber*).—A temperature of 80°

in the plunging material will be abundant for this purpose. We know of no separate work on the subject.

ADVERTISEMENT (*Jonathan*).—Send it to our office (Amen Corner, Paternoster Row), and you will be informed the charge before it is inserted, if you so request.

CLASSIFYING POULTRY (*Ashbocking*).—We fear that however desirable in some respects, it would be very difficult and objectionable in others; and we do not know where the judge is who would undertake the task.

POULTRY SHOW RULES.—C. S. W. we have no doubt could obtain those of Birmingham, by writing to the Secretary, Mr. J. Morgan; and those of the Metropolitan of its Secretary, Mr. Houghton, the Oval, Kennington.

WHITE SHANGHAE.—Mr. James Cattell, of Mosely, near Birmingham, obliges us by saying:—"In reply to "T. A." relative to the pure White Shanghae fowls, I have a cock and hen brought direct from there by Capt. Darke, last May. They were seen, immediately I got them home, by Mr. Bissell, of Birmingham, a well-known judge of poultry, and also by many amateurs in the neighbourhood. Capt. Darke at the same time brought over some White Silk or Negro fowls to W. S. Partridge, Esq., of Birmingham. A friend of Capt. D.'s, and I went on board for the fowls, they have never been out of my possession since, and I shall be happy to show them to anybody who may wish to see them."

COOKING FERN SHOOTS.—Capt. Beauchamp Walker, of Redland, near Bristol, has obliged us with the following note:—"In answer to a question in your number of January 20th, as to the use of Fern shoots as a vegetable, I beg to inform you that they are in constant use in the British North American province of New Brunswick. I have often eaten them there, and thought them very nearly, if not quite, as good as Asparagus. The extract from Huc's Travels in Tartary quoted, is exactly descriptive of the qualities and mode of use of this vegetable."

BACON-HOPPER.—*A Half-pay Officer* says: "I do not wonder at the works on Natural History not mentioning the *Bacon-hopper* attacking bacon, for it is only in that which is not well cured that it is ever found. It is most generally found round the bone in the gammon and in the shoulder, when left in the meat, in consequence of which, the most experienced curers of bacon have those bones removed as close down to the hock as possible, when the butcher is cutting-up the hog into fitches, &c.; and filling the vacant space with salt and saltpetre render it proof against their attacks; it has, however, occasionally been found in the fat part of the belly, but only, I believe, when there has been a great deficiency both of salt and of care in turning, &c., previous to its being placed on the rack to dry. I am also greatly obliged to Mr. Westwood for his reference to Vol. IV., as not being a cheese-eater, I had entirely forgotten it; I now recollect that fly, or one so nearly resembling it, that an unscientific person like myself would not be aware of the difference, frequently crawling or running over my book while reading. I shall note its first appearance with interest." Please to send specimens of the flies to I. O. Westwood, Esq., Brunswick Cottages, Hammersmith.

NAMES OF PLANTS (*Alpha*).—1, Mahonia Aquifolium; 2, Andromeda axillaris; 3, Rhododendron Catawbiense (?); 4, Laurus nobilis (the Sweet Bay); 5, Vebernum variety; 6, Viburnum Tinus (Laurestinus); 7, Quercus sp., we think, Gramuntia; 8, Something in the way of Cratogeomys crugalli variety, but uncertain; send us this in bloom and we will set you right; 9, Buxus sempervirens (Box); 10, Cytisus hirsutus; 11, Rhamnus alaternus; 12, Uncertain, send us this when in bloom; 13, Buxus sempervirens, variety variegata; 13, Buddlea globosa; 15, Rhododendron hirsutum variegatum.

J. B. W.—Your Orchid is *Oncidium roseum*.

TUBERS OF TROPOGOLUM EDULE (*W. D.*).—Can any of our readers say how these ought to be cooked.

CINERARIAS, &c. (*A. M. L.*).—All your *Cinerarias* are robust, showy flowers, and will be good border flowers. The only two likely to succeed as exhibition flowers, are the white one (No. 4), and the Albert blue one, with the lilac circle round the eye. This is very beautiful. The flower is small, but good in other points; it is likely to be an acquisition. Names of the plants next week.

PIGEONS (*W. Birkenhead*).—The pigeons that would be most suitable for the purposes you require would be the Runts, and their near relations the Trumpeters; both handsome in plumage, the latter especially so, and, moreover, very productive; but the Runts are not always found such good breeders. These should be the main stock, as, being of great size, they form a valuable addition to any bill of fare. If you wished for further variety, the Dragons—a cross between the Carrier and Pouter—might suit you; they are hardy, and attain considerable size. The house need not be fitted-up with any complex arrangement of nesting boxes; for if shelves be placed, in proportion to the number of pigeons kept, around the sides, fifteen inches wide, and one foot apart, with partitions every eighteen inches, to keep the breeding birds separate, further expense need not be incurred. Many fanciers use earthenware saucers, about eight inches in diameter, and two inches deep, for nests, and the birds take to them readily. A concrete floor would be easily swept, and prove a protection against vermin. The "self-feeding-troughs" we have never used. Your "sunning" place would be convenient for the birds till they are accustomed to their new home, when we presume you will give them their liberty. You may, indeed, keep them confined, but they will seldom do so well, and their cost is considerably increased, even in those kinds which, like those we have recommended, seldom go far from home. Any dealer could at once supply you.

WEEKLY CALENDAR.

M D	W D	FEBRUARY 10-16 1853.	WEATHER NEAR LONDON IN 1852.				Sun Rises.	Sun Sets.	Moon R. & S.	Moon's Age.	Clock bf. Sun.	Day of Year.
			Barometer.	Thermo.	Wind.	Rain in In.						
10	TH	QUEEN VICTORIA MARRIED 1840.	30.036—29.631	45—25	N.	02	26 a. 7	4 a. 5	7 40	2	14 33	41
11	F	Platysoma depressus; bark.	30.099—29.998	44—17	N.	—	24	6	8 51	3	14 34	42
12	S	Platysoma oblongus; bark.	29.914—29.664	43—25	S.	—	22	7	10 0	4	14 33	43
13	SUN	1 SUNDAY IN LENT.	29.824—29.584	42—30	S.	—	20	9	11 8	5	14 32	44
14	M	Valentine.	30.206—30.008	43—22	S.E.	—	18	11	morn.	6	14 29	45
15	TU	Hydrophilus caraboides; ditches.	30.191—30.100	49—33	S.W.	04	16	13	0 15	7	14 26	46
16	W	EMBER WEEK.	30.176—29.777	53—43	S.W.	03	24	15	1 23	8	14 23	47

METEOROLOGY OF THE WEEK.—At Chiswick, from observations during the last twenty-six years, the average highest and lowest temperatures of these days are 45.3° and 31.3° respectively. The greatest heat, 65°, occurred on the 10th in 1831; and the lowest cold, 3°, on the 11th in 1845. During the period 115 days were fine, and on 67 rain fell.

THE FOREST TREES OF BRITAIN.

UNDER this title, as opportunities occur, we intend to give portraits of such trees in the British Islands as are remarkable for their size, or beauty, or association with historical events. To aid us in this, we shall be very

much obliged by any of our readers sending us drawings of such trees as they are at present existing, with particulars of their dimensions, and a narrative of any traditions connected with them.



THE SALCEY FOREST OAK.

We should not act worthily, either as Englishmen or as lovers of the picturesque, if we did not give precedence to "the sturdy Oak—the eternal guard of England's throne;" and, "confessedly, both the most picturesque tree in itself; and the most accommodating in composition." It is suited to the grandest; and may with propriety be introduced into the most pastoral. It adds new dignity to the ruined tower, and gothic arch; by stretching its wild, moss-grown branches athwart their ivyed walls, it gives them a majesty coeval with itself; at the same time its propriety is still preserved, if it throws its arms over the purling brook, or the mantling pool, where it beholds

"Its reverend image in the expanse below."

Of all such forest antiques, not one is more reverend than "the Salcey Forest Oak;" and most justly has it been thus addressed—

"Thou wert a bauble once; a cup and ball,
Which babes might play with; and the thievish jay,
Seeking her food, with ease might have purloined
The auburn nut that held thee, swallowing down
Thy yet close-folded latitude of boughs.
Time was, when, settling on thy leaf, a fly
Could shake thee to the root—and time has been
When tempests could not—
Time made thee what thou wert—King of the woods—
And Time hath made thee what thou art—a cave
For owls to roost in!"

This magnificent ruin of a tree stands in the Forest of Salcey, in Northamptonshire, between the forests of Rockingham to the north, and of Whittlebury to the

south-west. This Oak, which bears a noble pre-eminence over all its brethren in the forest, in 1794, according to the account of H. Rooke, Esq., F.S.A., was in circumference at the bottom, where there are no spurs, forty-six feet ten inches; at one yard from the ground, twenty-four feet seven inches; at two yards, eighteen feet six inches; and at three yards, sixteen feet two inches. The height within the hollow was at that time fourteen feet eight inches, and the height of the tree itself thirty-nine feet three inches.

From the data given by Mr. South, in his letter to the Bath Society, on the growth of Oaks, Mr. Rooke calculates this "monarch of the woods" to be not less than fifteen hundred years old.

No historical tradition, that we know, is connected with this Oak, but there is a fellow veteran in the same county, of which Morton, writing in 1712, says:—"I

must not pass by the capacious hollow old tree, called *Stephen's Oak*, or as vulgarly *King Stephen's Oak*, one of the boundaries of Rockingham Forest, upon the borders of Brigstock and Sudborow Lordships, it being famous in the neighbouring county upon these two accounts. 1. From this very tree, according to tradition, King Stephen once shot at a deer, which if we may give credit to, the tree must be at least 550 years old (now 700). 2. So capacious is the hollow trunk of King Stephen's Oak, that at the Brigstock Processions (when it is their constant custom to fill the hollow with a company of boys) they generally put into it between thirty and forty of them, for so many will it hold without any difficulty." (*Gilpin. Strutt. Morton, &c.*)

We purpose next to give a portrait of "Wallace's Oak," and shall be glad of any relative particulars.

WE concluded our last article on orchards (page 337) by exhibiting the low condition, and almost total extinction which had befallen those of Kent, at the close of the last century. We then remarked, that the observations we were about to make with respect to Kent would apply equally to the orchards in other parts of the country; and, as a proof, we find about the same time, the late Mr. T. A. Knight was devoting his time and influence to the resuscitation of those of Herefordshire, which had fallen pretty much into the same declining state.

We have no means of judging; but, in the absence of positive evidence on the subject, we have every reason to believe that, in consequence of the gradual decrease of the home supply, the importations from foreign fruit must at that period have been considerable; and so, again, we are brought to a crisis similar to that with which Richard Harris had to contend nearly 300 years before. We are warranted in stating this supposition; for no sooner had we entered on that long and disastrous war, which raged from 1802 till 1815, during which time our commercial intercourse with the Continent was cut off, and our importations were either considerably restricted, or entirely stopped, then the price of fruit rose to an enormous height. But, till then, men had forgotten all about their orchards, and it was not till "the pressure from without," and the old urgency were brought to bear upon them, that they bethought themselves of the old trees, and the old orchards, which they had neglected and thrown away years before, and all at once they began to wish them back again. Numerous, doubtless, were the regrets and self-reproaches which many a one expressed, when his neighbours returned from Covent Garden, or old Fleet market, rejoicing over the five golden guineas they had got in exchange for a bushel of Apples. Many were the grave councils held across boundary fences of adjoining farms; and weighty were the sage remarks that met with ready acquiescence at market-rooms on market-days, and church-doors on

Sundays; and then, after each and all had talked themselves into the assurance that no doubt could exist as to the remuneration to be obtained, they set to work with all possible rapidity, liberality, and hope, to redeem lost time, by planting orchards, which some seven, or eight, or ten years afterwards might come into bearing—for there were no dwarf orchards in Kent in those days.

The high prices continued; those who had a supply congratulated themselves on their good fortune, or good judgment; and those who had none, grumbled because they had neither. Thus matters went on, with the usual attendants of complaint, disappointment, or dissatisfaction, till the conclusion of the war, and then, in 1816, there was an importation of foreign fruit. The protecting duty at this time was 3s. 2d. a bushel, but this was not enough, and great was the outcry against such importation being permitted. Memorials were prepared, signed, and presented, for an increase of duty. Orchards were again to be grubbed up, which had only a few years before been planted. Families were to be ruined, parishes depopulated, and the country sacrificed, because the orchardist could not realise "war prices" for his fruit, and because the consumer was enjoying his apple-dumpling twice a-week, instead of once as before. The outcry succeeded, and, because the price of Apples had fallen one-third, government raised the protecting duty from 3s. 2d. to 4s. in 1819. This was a great deliverance, and so the work of planting progressed to such an extent, that where there was an acre planted in 1802, there were ten planted in 1819. Still, notwithstanding the increased duty, there were 92,212 bushels imported that same year. Planting increased; Apples realised from 6s. to 8s. per bushel, and fruit became again one of the most important articles of produce in all the county of Kent.

We shall here subjoin a tabular view of the quantities of APPLES imported into this country, from 1819 to 1837, a few months before the 4s. duty ceased, and also the average prices at Covent Garden in each year.

Next week we shall review the subject from 1838 to the present time.—H.

Year.	Duty.	Quantity imported.	Average price at Covent Garden.		Year.	Duty.	Quantity imported.	Average price at Covent Garden.	
			s.	d.				s.	d.
1819	4	92,212	not known.		1829	4	31,093	3	0
1820	4	45,324	not known.		1830	4	22,462	5	6
1821	4	80,887	8	0	1831	4	52,615	6	0
1822	4	45,830	8	6	1832	4	16,537	3	6
1823	4	31,123	7	0	1833	4	27,087	3	6
1824	4	68,758	6	9	1834	4	18,447	3	4
1825	4	68,304	8	0	1835	4	11,574	3	0
1826	4	40,865	7	6	1836	4	14,859	3	6
1827	4	28,670	4	6	1837	4	20,502	2	3
1828	4	48,202	5	6					

WE have been favoured with an early copy of the Prize List and Rules of *The Birmingham and Midland Counties Exhibition of Poultry* for the present year. In them we see very gratifying marks of liberality on the part of the committee, demonstrating their willingness to increase the number and value of their prizes; and some improvements in the classification, but there are other portions of their arrangements still open to censure.

The days of exhibition are December the 13th, 14th, 15th, and 16th. This we cannot but again hold up as deserving the most determined reprehension; and we advise those gentlemen who are circulating their memorial for a reduction of the days of exhibition not to relax from their efforts; but to persevere in obtaining signatures, and to present it to the Committee. The intention to exhibit for four days is not like a law of the Medes and Persians—irreversible, and we think that the committee, when they see the recorded opinions and wishes of some of their best supporters, will give way upon a point which, we think, has no one plea in its defence, except a supposed advantage to the Society's fund; every dictate of humanity, and the interests of exhibitors and purchasers are totally opposed to such a lengthened period of exhibition.

A great improvement in the rules is that which declares that "*Chickens of 1853 cannot be shown in the classes for fowls above one year old.*" This, as we long since pointed out, will save the matronly hen from being brought in unfair comparison with the freshness and neatness so peculiar to the pullethood.

We are well pleased, though not quite satisfied, with this modified regulation:—"High condition, quality, beauty of plumage, purity of race, and uniformity in the markings, combs, and other characteristics, will, in all the classes for Fowl, be taken into consideration by the Judges in a greater degree than mere weight without these distinctions, if the more perfect specimens are at the same time of a fair average size."

We are not quite satisfied with this, because it has omitted some such warning as this:—"Trimming, or artificial alteration of the plumage, or of any other part of a bird, will disqualify it for receiving a prize." Such an announcement is fair to exhibitors, for with the liberties which we have seen taken with the top-knots of Polands, and with other parts of other varieties, it is

evident that some exhibitors do not consider trimming inadmissible.

The amount of most of the second and third prizes, and some of the first, are doubled; and a fourth prize is added to some of the classes.

In Poland fowls, all distinction as to ruffs, or no ruffs, is done away, which is a step in the right direction; as is, in the class for "any other distinct breed," the announcement that the judges will "*make their awards separately on each variety shown in the class.*" It is also an improvement giving prizes for *Turkies* hatched in 1853, as well as for birds exceeding one year old.

There are two separate and new classes for *Black Shanghaes*; and this, with some other increases, makes the number of classes amount to fifty-six, notwithstanding the reduction in the Polands, whereas last year there were only fifty-two classes.

FORSYTH MSS.

NEXT among these MSS. occur the letters of JOHN WEDGEWOOD, Esq., the originator of the London Horticultural Society.

Of this amiable man and most assiduous gardener, we have been obligingly furnished with the following brief memoir, by the Rev. J. A. Wedgewood, rector of Dumbleton, near Evesham.

"As to the immediate subject of your enquiries, the time and place of my father's death and burial, I have to observe that he died at Tenby, of bronchitis, consequent on an attack of influenza, on the 23rd or 24th of January, 1844, and was interred in the burial-ground of the parish church of Tenby. I am not certain as to the exact day of his death,* but if my present information is not sufficiently exact, I can obtain the precise date from my brother, Lieut.-Col. Wedgewood, St. Mary's Hill, Tenby.

"As to any biographical details of my late father's life, there is very little to be said likely to be of any public interest. His life was so entirely private and domestic, and so much out of the way of public men, or learned societies and institutions, and his disposition was so retiring and unobtrusive, that it affords very scanty materials for any notice of his life. He was the eldest son of the first Josiah Wedgewood, the founder of Etruria, and was born in March, 1766. He was sent at an early age to a school kept by a dissenting minister, a Mr. Holland, I believe, at Bolton-le-Moors, in Lancashire. Here he learnt the classics, and other branches of rudimentary learning. He remained some years here, and then returned to his home at Etruria, near Newcastle, Staffordshire. Some time afterwards he went to Edinburgh, along with his next brother, Josiah Wedgewood, and there studied various branches of science, especially, it appears, chemistry. After he had finished his residence and studies at Edinburgh, my father seems to have remained at home, assisting his father in the management of the works, and at the same time maintaining and extending a friendly inter-

* 26th January, aged 78.—*Gentleman's Magazine*, 1844, i. 333.

course with many young people of the neighbouring families, to whom the house at Etruria was always most hospitably open. During the years 1789 and 1790, my father resided abroad, spending one winter at Paris, and another at Rome. On returning to England, he continued at Etruria, assisting his father as before, till 1793, when he formed an affection for Miss Louisa Jane Allen, of Cresselly, Pembrokeshire, whose elder sister had previously become Mr. Josiah Wedgewood's wife, and was accepted by her, and their marriage shortly afterwards took place. By her he had a family of four sons and three daughters, and I may with truth say, that a happier union never took place, nor continued to the last with a warmer and more undeviating affection on both sides.

"After my father's marriage he resided some time at Tallaton; then for a few years in Devonshire Place, London. Then he bought a place called Cote House, on Durdham Downs, near Clifton. Here he continued till the beginning of 1805, when, in consequence of the ill-success of a banking house in London, that of Messrs. Davidson, Noel, Templer, Middleton, and Wedgewood, in which he had unfortunately embarked the larger part of the fortune which he inherited from his father, he was compelled to sell the place, and retired with greatly diminished means to Maer Hall, in Staffordshire, and then to Etruria Hall, where he remained till the end of 1810. From this time my father lived in various places; at Heavitree, near Exeter; at Betley, in Staffordshire; at Kingscote, in Gloucestershire; at the Hill, near Abergaveney, in Monmouthshire; and lastly, at Seabridge, near Newcastle, in Staffordshire. In 1843, he was affected with a partial failure of eye-sight, owing to a paralytic affection of the optic nerve, and in consequence of this privation was obliged to give up the pursuit of gardening, to which he had always been ardently devoted, and took up his residence for the few remaining months of his life, with his second son, Lieut.-Col. Wedgewood, then married, residing in Teuby.

"Wherever my father lived, he took the greatest pleasure in his garden, and at Cote House, especially, his gardens, both out-of-doors and under glass, were kept in the highest order. And even after his greatly diminished means prevented him during the remainder of his life from an expensive mode of culture, he never failed to make his garden, both kitchen and flower-garden, the admiration of all who saw them. My father, I may, perhaps, observe, was particularly fond of his kitchen-garden during the latter part of his life, even preferring it to his flower-garden, and by his regular and judicious arrangement of crops was eminently successful in producing a very abundant and excellent supply of vegetables from the limited space he had usually at command.

"My father was originally, as his parents had been, a Unitarian dissenter, but as far back as I can remember, he was a sound evangelical churchman. In politics, he was, by inheritance, and from personal conviction, a staunch Whig. But no one could be more loyal, nor more attached to the constitution of his country. Of my

father's character and personal qualities, I may, perhaps, as a son, be suspected of undue partiality, if I expressed myself as warmly as I felt. But I feel sure that not only his own family, but every one who enjoyed his acquaintance, will bear me out in testifying to his unvarying sweetness of temper, kindness of heart, and generous disposition; and to his eminently modest, retiring, and unselfish nature. He was well read in botany, viz., in the Linnæan system, then in vogue, but not unacquainted with the natural system also, knowing Mons. Decandolle's works, and having the advantage also of his personal acquaintance. He also had a considerable experimental knowledge of chemistry, and was not deficient in a knowledge of geology or mineralogy, in which subject he was much interested. He was also extremely fond of music, and was so far a proficient in it, that he used to perform in concerted pieces on the violoncello.

"It was during his residence at Cote House that my father, as I always understood from him, first suggested the plan of a Horticultural Society, which afterwards, under the able presidency of W. Knight, of Downton Castle, Mr. Sabine, and other able and influential colleagues, ripened into the Horticultural Society of London, of which Society my father was a fellow to the day of his death."

Mr. Wedgewood's letters to Mr. Forsyth extended over the years between the early part 1799, and the close of 1804, but they relate chiefly to gardening topics, of interest only to himself.

The first notice of any proposition to found an institution for the promotion of gardening, occurs in this letter, dated from Etruria, June 29th, 1801.

I have been turning my attention to the formation of a Horticultural Society, and have drawn up such heads as have appeared to me necessary for the first formation of the Society. It would be proper to add a preamble just stating the ideas of the first founders of the Society, and intimating that we wish to clash with no Society at present instituted, whose plans are different from ours. By this means we shall give no offence to any party. By not binding ourselves to publish annually, we shall not be obliged to expose ourselves to the world in an imperfect state, by publishing papers not worth making public. When you have read the enclosed, I shall be happy to have your opinion on it.

P.S. If you should see Sir Joseph Banks, will you be so good as to ask him his opinion of the plan, and learn how far we might have a chance of having his patronage of the scheme.

That a Society be formed, to be called THE HORTICULTURAL SOCIETY.

That the object of this Society shall be to collect every information respecting the culture and treatment of all plants and trees, as well culinary as ornamental.

That every new member shall be balloted, after a Society of — original members has been formed, and that every such member at his admission shall pay one guinea besides his annual subscription.

That a certain number of honorary members may be elected, who shall be admitted to the sittings of the society without paying any subscriptions. That two black-balls be sufficient to reject such honorary candidate.

That the Society shall, from time to time, publish a volume of papers of the same size and form as the transactions of the Adelphi Society, and that each member shall be entitled to a copy, but no honorary member unless he has furnished a paper judged worthy of publication.

That the Society shall annually choose a President, four Vice-Presidents, a Committee of Inspection, and a Secretary.

That the Committee shall have the power of selecting the papers for publication, and that no paper shall be published before it has been read at a sitting of the Society.

That no paper shall be published which does not treat of Horticultural subjects.

That it shall be considered within the intention of this Society to give premiums for improvement in Horticulture, whenever it shall be judged expedient so to do.

(To be continued.)

COVENT GARDEN.

NOTWITHSTANDING the dense fogs in which we have for several days during the past week been enveloped, reminding us of November, rather than February, the market begins to assume a good deal of the aspect of spring. The usual displays of early spring flowers are being exhibited on the gardening-stalls, and the gay Primroses, Crocuses, and Daises, with clumps of Snowdrops, remind us of the springs and summers that are past, and of the fleeting hours of this mortal life. How many of those of us who have written and read this short record may live to see the Primroses and Snowdrops of another spring?

There is still a good supply of all sorts of vegetables, and for the last week there have been numerous arrivals of very fine *Broccoli* from Cornwall. They are of a beautiful white colour, large, and close-headed. The sale of these is, however, dull, scarcely realising 2s. per dozen. *Savoy*s continue as before, at from 6d. to 1s. per dozen. *Greens* from 1s. to 2s. per dozen bunches. *Brussels Sprouts*, 1s. to 2s. per half sieve. *Sea-Kale* is abundant, and produces from 1s. 6d. to 2s. 6d. per basket. *Asparagus* is also more plentiful, and of much better quality than it has been, being much stronger than heretofore, and makes from 5s. to 7s. 6d. per bundle. *Turnips* are from 1s. to 1s. 4d. per dozen bunches. *Carrots* 2s. 6d. to 3s. 6d. per dozen bunches. *Onions* 2s. 6d. to 3s. per bushel. *Leeks* 2d. per bunch. *Rhubarb* comes more plentifully, and realises 9d. to 1s. 6d. per bundle. *Celery* 6d. to 1s. per bundle. *Potatoes* 84s. to 150s. per ton.

Fruit of all kinds is scarce. *Apples* still continue to make as high prices as we stated last week, and *Pears*, what few there are, cannot be had under 4s. and 6s. per dozen. The sorts are the same as we have enumerated in former reports.

Plants and flowers are very plentiful, and the supply daily increases. They consist of *Camellias* of all colours. *Hyacinths*, *Geraniums*, *Roses*, *Violets*, *Chinese Primroses*, *Heaths*, *Tulips*, *Cinerarias*, &c.—H.

GOSSIP.

EVERY gardener knows that the upper part of the roots of his young *Cabbage plants* are liable to be studded with very numerous small white lumps. These are galls caused by the puncture of a small Weevil, or Beetle, and upon being opened, each gall will be found to contain a small curved grub, white, with a dark

yellow head, and almost black jaws. They come forth when perfect, remain underground in the pupa state, and become perfect weevils early in the summer. It is the *Curculio pleurostigma*, of Marsham, and the *Curculio*, or *Rhynchænus*, or *Ceutorhynchus sulcicollis* of other entomologists. It is a very dark-coloured weevil, with greyish down over the wing cases, and the thighs toothed. If the wounds they make do not gangrene and swell into that form of disease known as Club-root or Anbury, they do not cause any apparent injury to the cabbage plants they attack.

There is no need to remark further upon the wetness of the now-closing winter, and we may sum up all that has been reported upon the subject by observing, that in every locality of the British Islands about one-third more rain than is usual fell during 1852. Of the mildness of the season we have had many reports sent to us; but, as they came from favoured spots in the south-west, we have not considered the results very extraordinary. The following, however, from Mr. J. Perkins, Thornham Gardens, Suffolk, from whom we shall always be glad to hear, is not open to the same objection. He says:—

“I beg to forward a few remarks respecting the mildness of the season, which perhaps may be interesting to a few of the numerous readers of your valuable work, THE COTTAGE GARDENER. The following plants are blooming in the open air here:—

“Stocks, Delphiniums, Senecios, Coronillas, Pansies, Mignonette, Verbenas, Clarkias, the beautiful *Nemophila maculata*, Anemones, Vincas, Violets, Virginian Stock, Hepaticas, *Helleborus niger*, Primroses, China Roses in abundance; also a Bourbon Rose (*Pierre de St. Cyr*), which, by-the-by, is one of the best Roses for a bed.

“Geraniums, Verbenas, Petunias, Gazanias, Anagallis, Salvias, and Calceolarias, are as healthy as we generally see them at the end of September. A *Cytisus Rhodophena* is coming nicely into bloom. Fuchsias have made shoots two or three inches in length, and a *Ribes* will soon be in broad leaf. The whole of the above have been without the least protection, and many of them in very exposed situations.

“Peach, Nectarine, Apricot, and Plum trees are very forward; and many of the feathered tribe are pouring forth their delicious notes as in the months of April and May.

“I should be glad to hear of the ‘state of things’ in other localities.”

We are not of the number of those who think that *Meteorology* will ever rank among the exact sciences; so that a gardener may tell for a certainty what he may expect on the morrow. As far as he is concerned, he will never derive more benefit from the science than being able to know the probable extreme heat, cold, and wet, of any particular period. Yet we are glad to see efforts made to gather facts in the science, even in the Island of Mauritius. There is there a Meteorological Society, and we perceive that the Society is putting itself in a condition to supply information collected not only on shore, but also at sea, in accordance with the recommendation made some time ago in a report on the best means of carrying out its objects. The land and the sea are the two sources whence information can be obtained. Meteorologists have hitherto confined their observations almost exclusively to the land, apparently forgetting that, as nearly five-sevenths of our planet are covered with water, the laws that regulate the winds and weather are to be searched for on the wide ocean, where they act

with greater uniformity and on a more extensive scale. Aware of this, the Society is endeavouring to procure all the knowledge it can from vessels trading to the port. A clerk is employed in copying extracts from ships' logs, so that, should Government be inclined at any future time to bear the expense of constructing wind and current charts for the Indian ocean, at least some of the necessary material will be at its disposal.

From the report of a recent meeting of the Society, we observe that the President has applied to the Major General Commanding, for the services of a few intelligent soldiers, to assist in taking hourly observations with the instruments expected from England. As there can be no doubt that the General will accede to a proposal having for its object the advancement of science, in this case a branch of science in which soldiers have already distinguished themselves as observers, we may expect to see at no distant time a volume of Mauritius observations inferior in no respects to those that have been made at the other colonial observatories. The annual publication of a volume of observations made in the colony and some of its dependencies, of another volume of the logs of vessels that may have experienced hurricanes in the Indian Ocean, and an ample collection of materials for the construction of Wind and Current Charts, are objects the attainment of which would do honour to any society; and we hope that as the necessary zeal and intelligence are not wanting, the Mauritius Meteorological Society will not be prevented, in consequence of any pecuniary difficulties, from pursuing the important course on which it seems to be now entering.

The expenses incurred in making and publishing the observations will, we should suppose, be defrayed by government. It is only the other day that the American government authorized £200 to be expended in copying abstract logs, for the purpose of furnishing Lieutenant Maury with materials for his Wind and Current Charts of the Indian Ocean. We hope to see a similar display of liberality on the part of the English government.

Poultry is still looking up. Captain Hornby is selling *Spanish eggs* at four guineas the dozen, and has £28 worth ordered. He sold a Spanish cock and hen the other day for twenty guineas, and refused sixty guineas for his London prize pen; but sold a pen (four) of chickens for thirty guineas, and sells all his chickens for five guineas each. Our correspondent may well say, "Now these are wonderful facts!"

PEACHES: PEACH-HOUSE CULTURE.

ABOUT this period the early Peach-forcer will have his blossoms past setting, and the fruit as large as peas, or, it may be, more advanced; the majority, however, will be only commencing, and it will be well to show forth the necessary proceedings in detail for the sake of the uninformed. The first thing is to thoroughly cleanse the house, if one be appropriated to them; walls cleaned; lime-wash, with plenty of sulphur combined, applied; and, indeed, everything done which can contribute to the wholesomeness of the air within. In addition, a slight stoving with sulphur, by blending a handful or two with decayed sawdust, and burning it in a vessel containing some red coals. The latter is an awkward game in unpractised hands; but I have been in the habit of using sulphur extensively for the last twenty years, and never suffered but once—that severely—which has induced the necessary amount of caution ever since. In applying it as a paint to flue-pipes, or other heated surfaces, I have never known any damage ensue, provided the surface to which it was applied never became too hot to grasp tight with the hand. It is to be hoped that the trees, whether planted out or in tubs, in pots,

or boxes, have received the dressing over their shoots so often recommended; if not, it is too late to venture it above half strength.

And now, we will suppose the trees trained, and with another leap imagine them (the house having been closed a fortnight, and a moist atmosphere sustained), just unfolding their blossoms. A somewhat drier air must be maintained now, in order to effect the impregnation of the blooms, without which all labours will be lost. There are those who disregard this point; but most good gardeners recognise the importance of a dry air for the dispersion of the pollen. Livelier fires should be kept, especially in bright days, getting them up betimes in the morning, and giving all the air possible about ten o'clock. About twelve, the trees may be well shaken with a kind of short sharp jerk; this, of course, has a tendency to disperse the pollen or male dust, which, under the above circumstances, will have become subtle; and this process may be repeated daily, until the corolla falls, when, of course, the fate of the tree is sealed as to its fruit. Syringing must now be resumed morning and afternoon—the former about seven to eight, the latter about three o'clock, battering the trees smartly from both ends of the house, and crossing the direction of the water in every conceivable way. As to temperature, I will give a table before concluding this subject.

At this period the development of the young spray will take place, for this follows immediately on the blooming process, and constitutes a most important period. Of course, everybody knows that disbudding has to be practised on trees artificially circumstanced. We should pause at this crisis, and endeavour to ascertain what relation the mere leaf bears to the infant Peach. That a tree in full health contains sufficient nourishment to set this infant Peach "on his legs," there can be little doubt; but that this stock is inexhaustible, must be denied. Nature, with the buds of trees, even as with seeds, has been exceedingly bountiful; not only is there enough for present need, but even a surplus; sufficient, indeed, to sustain the young fruits until the new elaborations take place. Such being the case, we suggest very moderate forcing until a fresh and extra supply of accretive matter is obtained, which will be when some of the first leaves are pretty well developed—say in another fortnight. Disbudding then must be attended carefully to, almost daily, in order to force a free development of the foliage on the reserved shoots, and to prevent confusion. On no account should a general disbudding take place at once; it is too severe a procedure, and, doubtless, has a tendency to paralyse the root-action. Commencing as soon as the quality and position of the shoot can be well distinguished, we would have the process carried on until the fruit is as large as marbles, by which time it may be completed; and the next point is to commence a course of judicious stopping.

Let us now take the root into consideration for a moment. I have said nothing about watering, at present, thinking that, as a matter of course, the borders (inside) would be necessarily dry, and that watering had been resorted to. If such has been omitted, let the loose and exhausted soil be scraped off the border surface, and then the border thoroughly watered with water of the temperature of 90°. The very next day, let a second application be made, using, in the second case, good manure-water of the same temperature. Four ounces of Peruvian guano to the gallon will be very proper; I prefer, however, combining with it soot and dunghill-drainings. The day following, the border may receive a new surface-dressing, about three inches of such loamy compost as Peaches like, rather rich; and this may be coated with two inches of rather fresh horse-droppings. These will constitute a good

medium for subsequent syringings and waterings, the latter with a rosed-pot, to filter through.

Return we now to the branches. In disbudding, care should be taken to leave the lowest shoots in any given angle or space between two branches, in order to prevent nakedness. Where two can be found in such situations, the lower may be pinched when three or four inches in length; this will make it a reserve or nursery shoot; it will form many buds towards its base for successive wood in future years. As to the rest of the disbudding, one remark is necessary: so manage affairs as, that at the end of the disbudding period, not a shoot is reserved but what is needed for the next year's operations. In general, from three to four young shoots may be reserved on any given young twig of the preceding year; say, one a leader, a couple on its sides at several inches apart, and a lower one, which, as before observed, if needed for reserve shoots in succeeding years, may be pinched when three or four eyes in length.

Let not, however, our readers be bound by this practice alone; we would not have them slaves to any mere routine. There is, after all, a sort of wilfulness in trees which is ever at variance with dry rules; and there are many occasions in which, instead of attempting to lead, we ought to follow. Many exceptional cases will arise which will require slight deviations from rules of practice, however good the latter may be, or however considered useful as general maxims.

Disbudding having been thus carried out, let the dresser turn his attention to what are termed "Robbers," that is to say, over strong shoots of the present year. In order to know these well the character of the wood must be studied. One thing is tolerably certain, and that is, whenever any young shoot shows the least tendency to burst its side-buds, such, unless assuming the character of leaders, where there is much trellis space to cover, may have their points pinched at once about six inches above the point, where this axillary spray is sprouting. This course persisted in, the wood next in point of strength, or, in other words, the true bearing wood of the succeeding year, will be much encouraged, and thus the strength of the tree, in a great degree, equalised—a most desirable result. Indeed, it is not possible to carry out this equalisation by any other means. I have tried all other plans during the last thirty years, and have conformed over every opinion during that period, but if equalisation of strength be a maxim, there is assuredly no other way by which to attain it.

But the benefits of this process do not end here. The fruit is enlarged in consequence. It is a well ascertained fact, that the fruit from young and gross Peach and Nectarine trees is not so fine as from mature trees, steady in growth; and why? Simply because in the former case there is a too rapid dispersion of the sap to allow of that kind of concentration of acretive matter which the mature and steady-growing tree possesses, and which is the surest accessory to highly fed and flavoured fruit. But whether or no these reasons may suffice, certain it is that such is the case.

My advice then, is, continue stopping as long as a proud shoot remains, even, if necessary, past the ripening time, unless, as before observed, a space of walling or trellis requires covering, when, of course, it becomes necessary to promote the extension of the tree; albeit, young laterals are employed to carry out that most necessary object.

I may now point to the absolute necessity for thorough cleanliness in every thing connected with Peach forcing; at least, as far as the atmospheric conditions are concerned; and as to insects, no man will ever excel in Peach culture who permits their ravages, even for a very short period. I will venture to affirm that two-thirds of the evils which have formed the

subject of complaint about the failure of Peaches, and which have been both loud and long, have arisen from the ravages of the Peach aphid alone. Climate is blamed, soil is blamed, winds complained of, a too damp situation, &c.; they *must* be covered, says one; they *not*, cries a second; wrap the stems in haybands, cries a third; whilst a fourth insists on the necessity of glass walls, &c.

Now it is notorious, that first-rate Peaches, in abundance, the crops seldom or ever missing, are grown annually in situations combining all these disadvantages, the only nostrum being a simple mode of treatment, in perfect accordance with the natural habits of the tree, and a retarding of the blossoming period by all possible means. But somebody may say: how do you prove the ravages of the aphid or peach-louse to be so important? This way. The aphid is sure to commence operations the moment the trees are out of blossom; the development of the young spray takes place at this period; this young spray it is which should furnish the future crop; if this first effort is crippled and paralysed, which it will assuredly be by three days ravages (unmolested) of the aphid, so surely will the next effort be delayed three weeks, at least; and this loss of three weeks it is which our climate may not tolerate. In very truth, if A. B.'s wood is three weeks later than C. D.'s, the presumption, yea, the fact is, that it will be less ripened by three weeks in October. Now this, although somewhat directed to out-door Peaches, may, I trust, enlighten our patrons as to their in-door trees; let them, we say, emphatically, beware of insects. Tobacco-water and fumigation are within the reach of all.

I may now close this paper with a few things of a more general character, previously omitted; and, first, temperatures. Throughout the Peach-forcing season, beware of high night temperature; the Peach can do little in the dark, yet it is astonishing, when the elaborative powers of the leaf commences, what progress may be made by taking advantage of an afternoon's sun, enclosing a great amount of pure solar heat. A very high maximum, as well as minimum point, therefore, may be given, or in other words, a wide range of temperatures; at least, so I have found it. As a broad maxim, let the heat exactly follow the light. To begin, dating from blossoming-time, let us say 40° to 50° by night, and 60° by day, laying on 15° more by sunshine, if convenient. When swelling fast, say 55° by night, and nearly 70° by day, running to nearly 90°, if you will, if sunny. During the stoning process be more cautious; no disturbing causes now. Be content with a somewhat moderated pitch. Through all these proceedings let young peach-forcers take care to give all the ventilation possible. Ward's cases will not suit Peaches so well as Ferns. And remember, that at ripening time they must not ripen fast; if luscious Peaches are required, throw your sashes wide open as often as you dare.

R. ERRINGTON.

BULBS.

(Continued from page 321.)

COLLANIA DULCIS (Sweet-fruited).—This genus bears the same relation to *Alströméria* as *Hæmanthus* does to *Amaryllis*; the fruit being a kind of berry, and the pulp of this species is eatable and agreeable to the taste. It grows near Pasco in Peru, at an elevation of from 12 to 14,000 feet, and is called *Cumpanillas-coloradas*, or Blush Bells, as we say "Blue bells," in Scotland. Both Matthews and Cruikshanks sent over specimens of it. Mr. Cruikshanks told me that it was the Blush Bells of the Spaniards, and that it grows in very poor land, and would be quite hardy in England. It has exactly the same way of growth as *Fritillaria*, with narrow leaves,

and more of them, and with only two pinkish flowers on a stalk.

COLLANIA ANDINAMARCANA.—From the lofty mountains of Andinamarca in Peru. A splendid thing certainly; half-a-dozen flowers, or more, of a beautiful pink colour mixed with yellow, hanging down in a close bunch from the top of the stalk, and not unlike the flowers of some *Blandfordia*.

COLLANIA INVOLUCROSA.—Is a still more noble plant, and the best of the genus known to us. The flowers are large, very long, for this genus; the stamens longer, and the style longest of all; the colour a delicate pale yellow tinged with green. It has not been brought over alive yet; but it must come. It grows at St. Mateo, near Culluay, or some such name, in Peru, where it blooms in November. They all want the same treatment as *Bomareas*.

CONANTHERA BIFOLIA and *SIMSII*.—We call these bulbs *Conanthers*, and of all the bulbs in the world they are the most difficult to deal with by the gardener. Botanists, I believe, were nearly in a fix with them some twenty years back (see *Cummingia*), but now the whole group, and there are not many of them, is placed in a transition state. To understand what that state is, let us suppose the *Lilyworts* to be an irregular field of say, corn, having another regular field lying a little way off beyond it. This second field, let us imagine to be *Amaryllids*; then the "little way," or isthmus, or narrow piece of land between the Lilies and the Amaryllids are occupied by the *Conanthers*. Twenty years ago they thought *Conanthers* were true *Amaryllids*; but now, that these things are better known, it is found that they are only "Squills with the ovary (seed-pod) partially adhering to the calyx and corolla," or, as above, in the transition state. We gardeners are worse off than this, for none of us can keep them for any length of time, and never flower them but once, and that only if we happen to get them from their native places in a fresh state. They come from the most singular climate on the face of the globe, that of Coquimbo, the northern part of Chili which borders on Peru, being that part of the coast where rain ceases, where the little rain that does fall hardly ever sinks three inches deep in the barren, hungry soil. Bulbs from this province (Coquimbo) have hitherto defied our ordinary rules of cultivation. Under *Cummingia* I shall give my own latest notions about the way we ought to deal with them; suffice it to-day to record my last trials of them. Mrs. Wray, of Cheltenham, had a large importation of bulbs from the plains of Coquimbo, twelve distinct species, with a statement of the sizes and the colour and habit of the flowers. Finding them sulky they were all sent to me; and I am sure that seven, if not eight of them were never described by any English author. I tried them experimentally for eight years, and only flowered one, a *Leucocoryne*. The *Conanthers* are very low plants with blue flowers, but they are not true bulbs, as represented in our books, but tuberous-rooted plants, with the habit of bulbs. September and October (the spring months in Coquimbo) is their season to begin their growth; and if hard frost is kept from them it is all they want, and I believe they would grow well in sand. If any of our readers could send me bulbs from this coast, carriage-free, I think I could find an easy way to flower them.

COOPERIA.—This is a genus of small bulbs, natives of Texas, whence they were sent by Drummond. There are only two species, or kinds, of them known to us, and one of them (*pedunculata*) with a stalk or peduncle comes so near *Zephyranthes* as to have deceived some writers. There is a figure of it in Sweet's "British Flower Garden," but not very true, under the name *Zephyranthes pedunculata*. The late Professor Graham called it *Sceptranthus Drummondii*. The one called *Chlorosolen* in our Dictionary is only a slight variety

from the stalkless (sessile) one called *Drummondii*. Both are all but hardy, and prefer a sandy border in the open air, where they flower from Midsummer till late in the autumn, without leaves, and ripen seeds freely. The scape has but one flower, and when that is over, the seed-pod begins to ripen, and up comes another scape to go the same round, and so on they go till after the leaves rise in October.

COOPERIA DRUMMONDII.—The flower scape of this species rises four or five inches high, and the flower stands upright on the top of it. The tube of this flower is nearly as long as the scape, or rather longer than the tube of *Fuchsia corymbiflora*, and about the same size and shape, greenish at first, but dying off a faint pink colour. The top part, or opening of the flower, is not unlike a large white Chinese Primrose, only that there are six divisions in the flower. This and the next one open the flowers only at night; but once open, they stand so for three or four days, and then fade with a blush tint. The way to show them off, is to have from twelve to twenty bulbs in a patch. There is no difficulty in getting a stock of them, even from one root, the first season, and the seeds ought to be sown, exactly like *Ixia* seeds, early in October.

COOPERIA PEDUNCULATA.—A shorter tube to the flower, and the flower having a stalk and peduncle, is all the difference between this and the last. The leaves of both are flat, very narrow, a little milky-green, and from a foot to eighteen inches long. Although they come very near *Zephyranthes* in affinity, and to *Z. atamasco* in locality, the latter growing in the southern parts of Carolina, the two families must not be planted together, because every species of *Zephyranthes*, without exception, goes to rest during the winter, while *Cooperia* is in full growth. Will any of them cross with *Z. candida*? a plant very unlike them in appearance, but differing very little from them in the private mark, that is, botanically.

CRINUM.—If it were generally known that some kinds of *Crinum* are as hardy as the new *Gladioli*, much easier to cross, and that they run into forms and colours, with which nothing that ever appeared in a Dutch Tulip can vie, surely people would grow them out in the borders, where they only require strong, rich soil, such as would suit brocoli and beans, and abundance of water for three or four months during hot summers, and in very hard winters to cover the borders with three inches of littery dung from the stable or framing ground. The largest and the best specimens that we have yet seen of the Japan Lilies are not to be compared in beauty or stateliness to some hardy crosses of the genus *Crinum* that we have seen, and yet the best of the original species, *Forbesianum*, has never been brought in contact with breeders till the summer of 1852. I have now only two bulb correspondents, and one of them thinks he has effected a cross last summer with the pollen of *Crinum Forbesii*, a splendid large bulb, from the banks of the Delagoa River, on the south-east coast of Africa, having from thirty to forty large flowers on a tall scape, as rich in colour, and something in the same way, as the flowers of *Passiflora kermesina (latissime purpureis)*. Now, this *Crinum* is just as hardy as *Gladiolus psittacinus*, from the self-same locality; and yet you will not meet with one gardener out of five hundred who ever even heard the name of it. When I say that the best-known *Crinum* in England is a stove plant called *Amabile*, that it is a cross between two others (*procerum* and *zeylanicum*), neither of which are half so handsome as *Forbesii*, and that it is quite possible to have much finer *Crinums* than *Amabile*, and hardy enough to flower out-of-doors with us, not only that, but that such bulbs are already in existence, and that they do flower from May to October every year, surely it is time to ask amateurs to take up the genus *Crinum* for cross-breeding, and to sell the

seedlings among the gardeners, who ought, before this time, to have worked them for themselves.

Crinum amabile is quite barren; it never furnishes pollen, neither will it seed; and there have been many such instances in the genus—seedlings coming to a dead lock at the first cross. There are three or four kinds of white-flowered *Crinums* from Australia, which cross freely, and produce fertile offspring, but as they are very little known I shall pass them, and mention only the three or four kinds from the Cape, which are well-known to bear seedlings from any of the Indian *Crinums* as hardy as themselves with the first cross. The best of the three is a dark purple variety of *Crinum capense*, named *Riparium* in Bot. Mag., 2688. The next best is the white variety of the same, which they grow in Holland, and which they sell by the name of *Amaryllis Africana*, *candida*, and so forth. The third best is a comparatively small bulb, with a long neck; it comes in every one of those boxes of bulbs which our friends purchase for us from the Cape dealers; the name is invariably called *Amaryllis longifolia*, or *capense*: this has a dull white flower, and milky-green leaves. There is a hardier kind even than this, with the leaves perfectly green, and the flowers die of a bright pink colour. It is difficult, however, to get it through the bulb dealers.

Crinum capense, or *Amaryllis longifolia*, is a very common plant in England, where it is quite hardy, and flowers from the end of May to October, and ripens seeds by the bushel, if it is planted in strong soil by the edge of ponds or lakes. It is a regular swamp plant, and rests all the winter out-of-doors; but in a pot in the greenhouse it is evergreen, and I have known it to flower in February. It will cross with almost all known *Crinums*; seedlings of itself, without being crossed, will flower the fourth season, and some the third year; when crossed, some of the seedlings take longer time to flower. *Crinum Goveni* figured in the third volume of the Hort. Soc. Trans., and named after R. Gowen, Esq., present Treasurer to the Society, is a cross from *C. capense* by the pollen of *C. zelandicum*, yet it is perfectly hardy, and very handsome and fertile. *Crinum Herbertii*, named by Sweet, is a plant of great beauty, bearing ten or eleven flowers on a scape three feet high, and quite hardy in front of a greenhouse, although a cross by the pollen of *C. scabrum* (Bot. Mag., 2180), a bulb from Rio Janiero, and the hardy *capense*. The *Crinums* called *Lindleyana*, purplish on the outside of the flower; *Lodigesianum*, from Mexico, with a large portion of purple in the flower; *scabrum*, striped with red, very beautiful; *zelandicum*, deep purple; *speciosum*, white, striped with pink; and *revolutum* (*Amaryllis revoluta* of the Cape), striped much like *speciosum*, are those that I would recommend for crossing with *capense* for beautiful, hardy, border plants. It is true that such crosses have been already obtained; but then they are in private hands, and by an illiberal and jealous system, they are likely to remain so until we raise them afresh, and get some to surpass them from the breed of *Forbesianum*. I once had half-a-peck of the seeds from, or, rather, said to be from, the best collection of them in existence, through the influence of an officer high in the Councils of the Horticultural Society; but after all my trouble in nursing five hundred bulbs for four years, the whole turned out to be nothing but the common *Crinum capense*. The seeds of this species are as large as horse-beans, but some species have them much larger.

D. BEATON.

COMBINING A GREENHOUSE AND VINERY.

“WILL the ordinary sort of greenhouse plants suffer from having a vine trained above them; there will be no heating, except in frosty weather, as the grapes

would not require to be forced?” The above is one of a series of similar applications from subscribers I would ever be anxious to serve. The matter has already received a fair amount of attention, but yet scarcely so much as its importance demands. The cheapness of glass has given both *power* and *ease* to the gardeners in some large establishments, inasmuch as they are thus enabled to devote a structure to one definite purpose. Success in such circumstances is not only more certain, it *ought* to be of a higher grade. Taken in the mass, gardeners have not been provided with houses at all in proportion to the greatly increased demand and supply required from them. At a vast increase of labour, therefore, which keeps us ever on the move—preventing us, at least, from getting rickety or gouty by inaction—most of us are forced to turn our houses to many purposes, though a main feature be preserved in each.

I cannot say that ever I have been so fortunate as to have the superintendence of a vinery that was not, during part of the season, made to do the duty of a greenhouse. I recollect a great nurseryman ominously shaking his head at me, many years ago, and muttering something about “madness;” and no wonder, perhaps, for there, in a small house, in a forenoon in spring, were grapes and peaches set, a guava and figs swelling, French beans and strawberries fit to gather, melons like pigeons' eggs, and cucumbers hanging like short gun-barrels, plenty of chicory and rhubarb in a corner, while, in addition to other plants, flowers of *Passion-flowers* and *Franciscea* scented the atmosphere. Now, I would by no means recommend our inexperienced friends to attempt such a variety of things in one house, each requiring different treatment; but, as the cheapness of glass has led many to build a house, I have alluded to the circumstance here, to show they need be under no alarm in attempting to combine the useful with the beautiful, by getting grapes to eat, as well as flowers to admire.

The successful results obtained often under such circumstances leave no doubt of this. Some of the finest grapes I ever saw were shown in September; and I knew well, from the same single houses, their respective owners exhibited good specimens of *Calceolarias*, *Cinerarias*, and *Geraniums*, at previous exhibitions, and also splendid *Fuchsias*. Of course the shows were made no secondary matter. Wherever there is a thorough determination to accomplish an object, difficulties only whet the invention, and increase the diligence. It has just started into my mind what Mr. Appleby said so favourably in the autumn respecting the Northampton show. I can fully confirm his statements—nay, more, I would say, that he by no means saw the best that the gardeners there could do; for, not to speak of other things, I have seen *Cinerarias* and *Achimenes* there such as I have never seen exhibited on London tables; but what struck me most of all was, in visiting some of the places, such as Courteen Hall, to find such small apparent means and conveniences to produce the seen results. A wag once solved my difficulty in respect to the above place by stating that, whatever the glass conveniences, it was no doubt *doubly gardenered*; but, however evident that Mr. Gardener had got a share of the professional mantle, it was also conspicuous that it was no stranger to the shoulders of his neighbours. Indeed, had that gentleman the *power*, he could not have had the willingness to keep it to himself. Paradoxical though it may seem, it is no less true, that young beginners, who wish to make the most of their conveniences, will often gain more suitable information in visiting small and moderate-sized places, than in pilgrimating to large and more celebrated establishments.

From these remarks, it will be seen that it is perfectly practicable to combine greenhouse plants and Vines in one structure. It will be necessary, however, for the

proprietor to determine the definite uses to which he applies his house, and the things to which, when the *pull* of destruction comes, he will give the preference. He must also determine whether this single house is to constitute the whole of his glass, or whether, as often advised, he will treat himself to a light or two, in the shape of a hotbed frame, and a few more lights in the form of a cold pit, with walls of turf, brick, wood, or whatever is most handy. Any of these conveniences would enable him to have more variety in his house in summer, and also, if he thought proper to give a slight forcing or extra heat to his Vines when they were in blossom, as the hardier plants would be placed out-of-doors; the more tender, as respects full exposure, in his cold pits; while tender annuals and *Achimenes*, assisted by the frame, would come in as summer ornaments.

Let it be taken as a general rule, that the lower the temperature which a plant will stand in winter, the more it will be injured by a closish, shady atmosphere in summer. The not having a few Vines merely to give a slight shade, but covering the roof with them, is the reason why so many, who pride themselves on their bushy plants in spring, get disappointed with the same plants being drawn and leggy in summer. A greater amount of light and of air would have prevented this; but the greater quantity of air would not so well have suited the Vines. In such circumstances, they receive only a few advantages over that they would possess when trained against a warm wall.

Another general rule to be kept in mind is, that every vinery may be used as a greenhouse from the time the fruit is cut until the bunches are again freely showing themselves; then you may give greenhouse treatment for the season, or a little extra heat, either by fire, or confining the heat from the sun, just as you give a preference to hardy greenhouse plants, or a superior well-swelled crop of grapes. I have said after the fruit *is cut*, but an amateur friend, who fills his house in October, has managed to have grapes at Christmas, simply by encasing the bunches in bags of bladder after a dry forenoon. During summer—his flowering plants are chiefly confined to his wide front shelf—he appropriates the stage to a few *Achimenes*, *Balsams*, and the growing of his *Camellias* and *Azaleas*, before hardening them out-of-doors in August. In that house, I have seen *Bulbs*, *Epacris*, *Camellia*, *Genista*, *Acacia*, *Erica*, &c., all in bloom in winter; *Cineraria* and *Calceolaria* in spring, and adorning exhibition tables in May; *Pelargoniums* equally beautiful in June; *Fuchsias* in July; *Achimenes* and *Gesnera Zebrina* in August and September. In the latter month, grapes have taken a prize at a country show. In addition to the house, there was a small pit of four or five lights, used chiefly as a preservative for choice florists' flowers in winter, part of it used as a cold resting place for favourite plants in summer, and another part used as a hotbed, for helping on tender things, and growing regular exhibition cucumbers. I must state, however, that all this was done by sacrificing *quantity* to *quality*. He was much more gratified with two bunches of grapes that beat all his neighbours, than if he had had six times the number of bunches, and four times the weight, but the individual bunches inferior. His principle was—*what can you show* as proofs of good gardening, not *what have you got at home*—a principle of first-rate import for all intending exhibitors to study, as has been previously demonstrated. The most of his soft-wooded plants, and the hardier hard-wooded ones, being out of the house early in June, except what could be accommodated on the front shelf *thinly*, he was thus enabled to keep his house closer; and if, during the times when the Vines were coming into bloom, or swelling freely, a few very dull cold days intervened, he would give air, but also put a

little fire in his flue. The Vines, as they ought to be in such circumstances, were trained and pruned on the spur principle,—one Vine to each rafter, the rafters being rather more than four feet from each other. The Vines were planted outside, in a raised border, two feet deep, with a drain and nine inches of open rubble underneath. The border was twelve feet wide, the part next the house being eighteen inches higher than the front, and that even slightly raised above the surrounding ground.

The *soil* was equal parts of the garden earth, which was good, and fresh turfy fibry loam, mingled together with several loads of brick rubbish, and a few bushels of broken bones. In winter this border was kept mulched with good dung. In summer it was raked off and the border forked on the surface; but nothing was grown on it but a row of mignonette at its front. In summer it generally receives one or two manure-waterings, and now and then it has had a sprinkling of guano, or bone dust. The Vines were pruned and trained, and summer-managed much as detailed in No. 92; or, perhaps, it would be more proper to say, according to the copious, clear instructions of Mr. Errington. Our friend has been so successful, that among his acquaintances his practice is getting to be looked upon as a good model for imitation.

Now such a combination of good grape and plant growing is founded chiefly on two facts, the basis of the above general rule. First, that a general collection of greenhouse plants may be successfully grown and bloomed, in winter and spring, with an average night temperature not above 45°, allowing from 5° to 10°, and even a few degrees more, for sunshine. And secondly, because such a temperature will not start the vines much sooner than the buds would have swelled under glass with no artificial heat whatever during the winter. As will have been seen, the future treatment will depend upon whether grapes, or greenhouse plants, are considered the most essential; whether a little extra heat be given, or not given, in summer; or whether the plants may not be so changed that the greatest amount of beauty may be realised, with, in the circumstances, the greatest amount of profit. Keeping in view that the inquiries made relate chiefly to a house that is to receive little or no artificial heat in summer, I will, to meet a number of cases, say a few words on such a house when used as a *Preservatory* in winter, for window and out-door adornment in summer, when greenhouse plants are to be reckoned of most amount at all times; and again, when grapes and flowers are deemed equally valuable, and there is a small amount of glass; besides alluding to the management, and some of the plants that will be best suited for the different circumstances. But these matters I must defer to another opportunity.

R. FISH.

THE PELARGONIUM.

IN no class of florists' flowers has there been so great an improvement as in the Pelargonium, or, as it is commonly called, *The Geranium*. The race now in existence, as exhibited during the past year, is as much superior in form, size, and colour, to the first hybrid, as the finely-formed and highly-coloured double Dahlia of the present day is to the first raised semi-double, half-formed, and badly coloured Dahlia. Then, again, the culture of the Pelargonium is greatly improved. Gardeners advanced in years, like myself, well remember the day when the Geraniums were grown on the stage of the greenhouse, almost as thick as mustard for salads, so that if a plant was taken out from amongst the crowd to be placed in the parlour window, or in a basket in the sitting room, its tall lanky stem required a strong

stake to keep it from betraying its weakness; but, if we consider the plants that are grown now, whether for exhibition, or only for ornament, even the most fastidious observer must allow that the schoolmaster in culture has been abroad and learned more than a little to teach the young race of cultivators that the old mode of growing plants is now only a mark of ignorance and stupidity, or something worse.

To discern a good grower, a clever, industrious, and enterprising man, we need only look at his plants, whether they be a common Geranium, a Fuchsia, a Cineraria, a Heath, or any other plant. If any of these, whether young or old, are grown in an indifferent, careless way, the cultivator is set down as *one of the old school*, and valued accordingly. As one of my correspondents, now in want of a gardener, justly remarks, in a letter now before me, "it is better to grow one plant well than 500 badly." If a plant is worth growing at all, it certainly is worth growing well.

The great difficulty is to be content with a certain number of plants, so as to allow each its due share of light, space, and air. This is the great stumbling-block of most cultivators, they want to grow too many varieties, or too many of each in the space they possess. Perhaps it is easier to raise plants than it is to have courage to throw away the superfluous stock; or, it may be, that a gentleman or a lady visits a Nursery celebrated for plants, sees them well grown, and in fine bloom, and is struck with their beauty. Desirous of possessing a plant of each, a considerable order is given and sent home to an already over-stocked stove and greenhouse. They arrive, and the poor gardener is sadly puzzled what to do with them. The old ones he dare not throw away, and the new ones must, at all events, be taken care of; and the consequence is, that although probably a very good gardener, dissatisfaction arises, and he is discharged or rendered very uncomfortable. In such dilemmas, all that is required is a consultation between the parties, and an understanding that if new plants, whether Geraniums or any other tribe of plants, are to be purchased, either room must be made for them by discarding an equal number of plants of older varieties, or more glass must be put up to cultivate the additional plants under. The grand rule to be observed in growing *Pelargoniums*, or any other plants, is never to allow the leaves of each plant to touch or interweave with its neighbours; the moment they do, in consequence of growing larger, they must—aye, *must*—be set farther apart; there must be no doubt or delay on this point.

With these few preliminary remarks, I commence a paper or two on *Pelargonium* culture, with a view to finishing with a descriptive list of the best kinds or varieties for 1853; and should be glad if some of my readers would assist me by sending lists of such as they know to be first-rate in properties. Already, without asking for it, I have had a list from one person, my esteemed Berwick correspondent, for which I heartily thank him. In this day of railroad speed, it might reasonably be supposed, that as soon as a good variety of any florists' flower was raised, the fact would be known almost immediately, though the parties were as widely separated as the Land's-end from John o' Groat's house; yet it is not so, unless the parties, through the medium of pages as widely circulated as these, made known their success. We have already seen what has been done by the growers of *Pansies*; they have sent lists of their collections of that charming flower; and I know, in more than one instance, changes have been made in consequence. No doubt the lists of *Pelargoniums* from many of our readers would lead to similar results.

As usual, I shall divide *Pelargonium* culture into different sections; a method which renders the subject more perspicuous and more easy to remember. 1st,

Propagation; 2nd, Summer treatment; 3rd, Winter treatment; 4th, Preparing for exhibition; 5th, Diseases; 6th, List of the best kinds for 1853.

It is well understood that both myself and my able coadjutors write principally for amateurs and the beginners in cultivation, and therefore the directions given on any subject of gardening or floriculture are as simple and full as our space will allow. Many of our observations may possibly call up a smile on the faces of the knowing ones. For such we do not write; and I must deprecate their criticism, by stating the fact over again, that we write for the information of those who are willing to learn and value the directions given in the pages of THE COTTAGE GARDENER.—T. APPELBY.

(To be continued.)

CONIFERÆ.

(Continued from page 325.)

1ST—SECTION OF PINUS, WITH LEAVES TWO IN A SHEATH—
(CONTINUED.)

PINUS LARICIO (Larch Pine).—This is an European species, inhabiting the island of Corsica, Spain, Greece, and Italy. It is a handsome species, and attains the considerable height of 100 feet. Our readers must not confound this with the common Larch (*Larix Europæa*), which is, as is well known, deciduous, whereas the Larch Pine is a beautiful evergreen, easily distinguished by its very intensely green foliage, long tapering buds, and small cones, and its regular mode of growth. It is a suitable species to plant on sandy soils, and will bear the severest frosts of our winter. There are several interesting varieties, which are all worthy of cultivation. Their names are *P. laricio pygmæa*, a small, dwarf, slow-growing variety, seldom exceeding from three to four feet; *P. L. monspeliensis*, *P. L. altissima*, *P. L. Corsicana*, *P. L. Calabrica*, and *P. L. Caramanica*.

PINUS MASSONIANA (Mr. Masson's Pine).—So named, by Mr. Lambert, in honour of Mr. Masson, a botanical collector, who resided several years at the Cape of Good Hope. It is a native of China and Japan, where it grows to the height of seventy feet. A handsome distinct species, and perfectly hardy.

PINUS MITIS (Soft-leaved Pine).—An American species, producing the yellow deal of commerce, and is a very handsome species. Its young shoots are particularly beautiful, being of a rich violet colour; the leaves are long and slender, the cones long, and the scales prickly. From the fact of it growing in New England on the poorest soils, in low situations, it might be advantageously planted in similar situations in this country. It is perfectly hardy.

PINUS MUGHO (The Mugho Pine).—Its native name. This species is found, but rarely, in the forests of Austria. It is a curious species, and there are two distinctly marked varieties, named *P. M. pumilio*, and *P. M. obliqua*, very proper, on account of their curious appearance, to be planted in a conspicuous place in the Pinetum.

PINUS MURICATA (Prickly or Scaly-coned Pine).—There is a great peculiarity in the scales of the cones of this very distinct species: the outside of the scales are round, and lengthened out, and bent back near the base; but those in the inside are square, and nearly flat. It is a rather low-growing species, seldom exceeding forty feet. It was found in California, by Mr. Hartweg, growing in mountainous places near the sea.

PINUS PALLASIANA (Pallas's, or the Tartarian Pine).—Native of Taurus. A fine species, and very ornamental, with long leaves, and very large cones. As it is such a fine species, and coming from a cold country, it is well worthy of extensive culture.

PINUS PERSICA (The Persian Pine).—So named by the Hon. W. F. Strangways, but very little is known of it. It has proved to be quite hardy in Britain.

PINUS PINASTER (The Cluster Pine).—This well-known Pine forms a handsome pyramidal tree, with long leaves and fine cones, which are produced in clusters, and have given it its specific name. Like *P. mitis*, it grows rapidly on poor, loose, stony soils. The late Lord Calthorp planted it largely on some stony hills near Hartford Bridge, in Hampshire, and lived long enough to see those previously barren hills covered with this beautiful, dark, evergreen tree. It bears the strongest blasts without being uprooted, because the roots descend deep into and amongst the small stones in such situations, hence it is a proper tree to plant as shelter to the more spreading-rooted Coniferæ. Having been introduced so long since as 1596, and producing its fine cones full of good seeds, it is now almost as cheap as the Scotch Fir, or, at least, very soon would be if it were required, or if there was a call for it by planters. It grows to the height of fifty to sixty feet. The varieties of this beautiful species are somewhat numerous. They are—*P. pinaster Lemonianus* (Sir C. Lemon's): this was raised in England; *P. pinaster Hamiltonianus*, raised in Italy; *P. pinaster Escavenus*, from Italy, and *P. pinaster maritimus*, which, as its name imports, is a suitable species to plant on lands near the sea.

PINUS PINEA (The Stone Pine).—The botanists Bauhin, Brothers, named this *P. sativa*, because the nuts are safe and good to eat. In Italy it is cultivated to ornament the villas to a great extent, as is also the variety named *P. fragilis*. Unlike the generality of the Pine tribe, this species is what is called a round-headed tree, growing to the height of sixty feet. In its young state, the foliage is of a beautiful milky-green hue; it is quite hardy.

PINUS PUMILIO (The Dwarf or Mountain Pine).—Though named the dwarf, this species, in good soil, and rather crowded, will attain twenty feet in height. The leaves are short, and branches numerous. There is a fine specimen on the lawn in the Royal Gardens at Kew.

PINUS PUNGENS (The Prickly-coned Pine).—Native of North Carolina, growing there from forty to fifty feet high. This is a remarkable tree, producing its cones in clusters round the stems of the branches. They are of a beautiful yellowish-brown, and remain on the tree for several years.

PINUS PYRENAICA (The Pyrenean Pine).—Though a native of the Alps of Europe, this beautiful species was not introduced here till 1834, by Captain Widdrington, who says of it that "it is quite hardy, of quick growth, and, from its noble appearance, the beauty of its form, and the clear transparent colour of both the bark and the foliage, it is likely to be a vast acquisition to our park scenery. The timber is white and dry, being nearly without turpentine; but the cones exude a most delicious balsamic odour, as do also the leaves." In its native mountains it attains the height of seventy feet.

T. APPELBY.

(To be continued.)

HOTBEDS FOR EARLY VEGETABLES, AND ROUTINE OF THE SEASON.

FROM the great demand there is for early vegetables, it is not to be wondered at that varieties have been multiplied almost to infinity, and every means available devised to bring them into use at the earliest possible period. Now, many vegetables present a delicacy and freshness in a young state which are in vain looked for in a more perfected one; consequently, it need not be surprising how much more popular the one is than the other. Potatoes are especial favourites when in a

young state; the first Peas of the season as so likewise: Turnips are scarcely less so; while Carrots, French Beans, and a host of other things, are alike desirable, if to be had some time before they are produced abundantly in the ordinary way. Now, though most of these things may be grown with a fair share of success on some heated bed under glass, yet the scarcity of the latter commodity at this time renders it impossible to give each of them that advantage. It is, therefore, advisable to try some other mode, whereby an amount of artificial heat may be afforded them without the glass protection, but some rough substitute adopted instead. Hot dung and leaves, tempered into the condition of furnishing a steady, regular heat, may be made into a series of beds, and a few rough slabs, nailed together at the corners, may be placed thereon to keep on the soil and the soil thrown on.

Potatoes may be planted, or seeds sown, which may be protected by anything handy at the time. Mats, supported a few inches above the surface on some rough frame-work, or even laid on boughs or other rough contrivances, will do very well, only they must be taken off in the mornings when the plants make their appearance, in order that they may get the light so essential to their well-being. An oiled calico covering will be better, because it will admit a large amount of light through, and may be useful on cold or stormy days. Additional covering may be put on over this if necessary, and the whole may be made as snug as some ordinary frames on hotbeds.

In this kind of forcing the growth of certain vegetables, the accelerating power is at the root, the top derives but little assistance from the heat supplied, but this, though doubtless a loss to the plant, it is still an object to obtain it with the least possible expense, and consequently, these rough-made-up hotbeds, with their skeleton frame-work surrounding them to keep up the soil, are, nevertheless, extremely useful, from the little trouble they give, and the sturdy growths of most things cultivated thereon. We therefore advise our young friends, who have fermenting materials at hand, to select a suitable open, sunny place, and there erect them. Slight beds of two-feet-and-a-half high will do; and we have often used very rough materials in their formation. Soil of a suitable light and open texture may be thrown to the depth of about eight inches, and the seed sown, taking care to select the best early variety of the kinds used. *Wood's Early-frame Radish*, *Lee's Early Horn Carrot*, *Fulmer's Early-forcing Kidney Bean*, and the best and most prolific *Early Potato* known.

Of *Potatoes*, generally, each district has its own peculiar favourite, and for forcing in this way we prefer a round one to the Ash-leaved kidney varieties, while the latter is preferable under glass, because the shortness of its top gives it a preference where the haulm is sure to get large enough. When, therefore, there is no particular wish to have a kidney potato, the round ones will be found more prolific and useful for general purposes; but if a preference be given to the kidney from its superior eating qualities, it may then be planted somewhat closer than the larger top round kinds. It is usual to plant them on these elevated beds in rows about fifteen inches apart, and sow an alternate row of something coming into use shortly, as radishes, lettuce-plants to prick out, or any other small crop; but, be it remembered, that if the potatoes flourish and succeed, they will speedily grow and overrun the frame or bed, and smother all extraneous crops. Much good must not, therefore, be expected from this mixture, and it is better to have the seedlings by themselves, where they may be sown thicker than usual to allow of the casualties that are likely to attend a crop in which contending agents of heat and cold

often operate upon at one and the same time. Protection from heavy cold rain ought also to be applied if possible; and those who have a series of brick pits with wooden shutters will have all the benefits they seek after in that way, as their coverings turn the rain; but where anything of that kind is to make, it had better be glazed at once, for however useful a deal door may be to exclude frost and cold, it is worse than useless in the day time, and we often have very cold, chilly days in spring, to say nothing of snow and other evils, against which the delicate foliage of a newly-developed vegetation has a poor chance of surviving. A still more homely, yet not-to-be-despised, protection, is by sticking the bed all over with evergreen boughs, which, however, must be renewed betimes.

Attend carefully to *Melons* and *Cucumbers* that may be progressing. The dull weather at the end of last month was very unfavourable to these fruits; however, the increased length of days, with other advantages, will accelerate their growth, to encourage which, be sure to maintain a nice, sweet, lively heat, sufficiently moist to be agreeable, without being entirely enveloped in steam. If you have had recourse to dung-beds, be sure that due and effective linings be applied in time; if fire-heat in any shape, the amount of warmth supplied is usually more at command, although the due proportion of moisture that accompanies it is more difficult to regulate, but it must be done if possible, otherwise a sickly growth and premature decay is the consequence. Give air very sparingly, except on mild days, when the admission of a little will be grateful to the plants inside. Give a little tepid water to plants in pots that may be standing about, and prick out others from the seed-pot as they require it, sowing more when needful.

Attend to the *digging* and preparing of ground for sowing the principal spring crops. *Onions*, which require sowing early in March, ought to have the ground prepared for them at once, otherwise it will not have time to mellow down prior to being wanted. *Manure* and dig any places left undone until now, and let all other work connected with the winter be finished as early as possible. Dung, or leaves that have been used in forcing Sea-kale, &c., may be wheeled away to vacant squares, leaving, however, sufficient around each plant to secure it against cold and frost that may visit us yet. Plant *Potatoes* on warm, sheltered borders; and plant out *Beans* that may have been in for forcing purposes. Examine and cut the various *Brocoli* that come into use, and note down any peculiarity respecting each individual kind. The past winter having been mild, these have been more plentiful than usual, and notes on the excellence of any particular variety, though good in its way, must not be implicitly relied on another season, which may be severe, and, consequently, death to some of the kinds differing but little from the Cauliflower. *Brussels Sprouts*, and the whole tribe of *Kale*, have never ceased to grow during the past season, and, consequently, there is no lack of them. The same may be said of *Spinach*, and, in many instances, *Lettuce* and *Colewort Cabbages* as well, while *Celery* has kept worse than usual, the wet weather inducing decay, while the mildness of it encouraged growth in such as resisted decay, and the consequence is, that abundance of what was expected to be good *Celery* is run away, and will speedily be rendered useless.

The earliest *Peas* will now require sticks, *i. e.*, if they have escaped the mishaps many of them are liable to in an unusual season. Those which hitherto look robust and strong, desire a little extra protection when bad weather does set in, otherwise they are liable to become what gardeners term "black in the leg," which is a disease analogous to what carries off many plants and vegetables that have attained a too forward state when the bad weather sets in. Sticks of a closer kind, or what

is better, mats occasionally thrown over them on cold nights will save them very much; but still we expect the second crop will, in many instances, exceed the first one for earliness and fruitfulness. *Beans* are hardier, but when too forward, are likewise subject to the misfortune named above. A sowing of each of these may be made; *Peas*, in fact, may now be sown every fortnight, and *Beans* the same, provided the demand for them be equally great, which, however, is not always the case.

J. ROBSON.

A WORD TO SPINSTERS.

By the Authoress of "*My Flowers*," &c.

IN one of my former papers I drew the picture of a widow who gave up the "promise," to enter upon a second married life. I am now going to address the unmarried women who may be thinking of taking a first step in matrimony, and would earnestly call their attention, *now*, while it is not too late, to a few facts which may be a wholesome warning, and prepare them a little for circumstances which *do* occur sometimes, and which *may* come upon them in an hour when they think not.

Eliza Gibson was a highly respectable young woman, the sister of a wealthy farmer; she had received a very fair education for her station in life, and had been brought up as a governess. For some years she had settled in a village as the mistress of a little school, and she had a number of very respectable children sent to her as day-scholars. She was going on quietly and comfortably, and I *suppose* she had saved up a little money, for it fell upon a day, that she was asked in marriage by a man who looked much younger than herself, and who was very busy with all kinds of contrivances for getting a living. He was always *at* something; making hay-rakes, buying old tumble-down horses, taking little bits of copse-wood for faggot-making, in short, turning his hand to anything, and seeming to be very active and industrious in all his ways.

Very much to the dissatisfaction of her friends, Eliza Gibson became Mrs. Jolliffe. She was quite old enough, and independent enough to marry when and whom she pleased, but I never yet heard of, or saw a marriage undertaken against the wishes and advice of friends that had not a thorn in it. There *must* be a *something*; affection blinds one's eyes, but lookers-on see clearly; and when the deed is done, and we have settled quietly down, many things rise up to the surface that are not nice, and it is too late *then* to skim them off; the bitter and the sweet cannot be separated *then*, they must be mixed together for ever.

Mrs. Jolliffe kept on her little school, but they took a much better house, and seemed to be going on pleasantly enough; but she very soon repented of her choice, and doubtless wished herself Eliza Gibson again. She found her husband a man of low tastes and habits, different from anything she had ever been used to, and this shocked and distracted her. He used to have dealings with gipsies, about old horses and other things, and he would bring these people into his house, into his wife's neat parlour, and keep them talking, and drinking, and smoking there, to her horror and disgust. His conduct to herself must have been brutal too, from what has since taken place, but she could not help herself; she had taken him "for worse," as well as "for better," and all she had to do was to bear it. At length, however, her health began to give way. She kept on her school, but she was evidently breaking down; and in the course of the last autumn she was obliged to dismiss her little pupils, hoping that after Christmas she might be well enough to take to them again. Alas! that time never came for her. Before the winter holidays were over she was laid in the churchyard, and her place knew her no more.

Very strange reports got about during the few weeks before poor Mrs. Jolliffe's death. Her husband would let no one go near her; he had a little girl in the kitchen, but no one else, and he waited upon his wife himself. When any one called to enquire, he said his wife was much the same, but could not see them; not a creature could get to her. This seemed strange, but at first it was not particularly noticed. At last, a very respectable woman, who knew

Mrs. Jolliffe well, really forced her way to the room where she lay, and was agonized at the sight she saw. The poor creature was in a state of delirium, lying on the bed, covered over with one dirty blanket; nothing else! There was no comfort; no common necessary things; no food by her bedside; all was wretchedness, cold, and misery; and in the midst of this lay Mrs. Jolliffe quite delirious!

Her friend said all that she felt to the monster who stood beside his victim, but he took no heed; he only passed it off, and got her out of the house as soon as possible. Nice, nourishing things were constantly sent to the house, but *it is said* he never gave them to his wife, and his conduct warrants our believing it. Enquiries were made of the local authorities whether something could not be done, whether the poor woman could not be rescued from the hands of so cruel a husband, and be taken proper care of. The answer was, that a man was master of his own house, and of his own wife, and that if he refused to let any one in an entrance could not be enforced.

Whether this is, or is not, the law of the land, Jolliffe gained his point; and if he did not kill his wife outright, he caused her to die; in what state, and what suffering, the eye of Him who neither slumbereth nor sleepeth, and "from whom no secret is hid," alone can tell; but "*His eyes are upon the ways of man, and he seeth all his goings.*" There is no darkness, nor shadow of death, where the workers of iniquity may hide themselves."

The tears of poor Eliza Jolliffe are put into "the bottle" of the Lord; not one of them is lost. Every sigh is written down, and every sorrow is noted in a book. The day will come when that book and that bottle will both be opened before the eyes of him who caused them, and in the presence of men and angels. "Woe worth the day." It will be, indeed, a "cloudy day" for that cruel spirit, except he repents of the evil he hath done. He shall call upon mountain and hill to cover him, but they shall stand fast; the Lord will "mock when his fear cometh."

Eliza Gibson thought nothing about Jolliffe's character when she married; she *must* have cared nothing about it. She was getting on in life, rather looking down the other side, and perhaps the prospect was somewhat dreary, as she gazed upon advancing age. But what dreariness can be so sad as an unhappy, an unholy marriage? Better live in a cell with a spider for company than be tacked to one who neither fears God nor regards man. *We* are too apt to disregard this. We are too apt to take those who have pleasant manners and civil tongues, instead of roundly and fearlessly asking them "the reason of the hope" that is in them, and waiting for a sound answer. We do not know, or care, about our own "hope," and therefore we neither ask that first and greatest question, nor could tell, if we did, what the reply ought to be; and this is the reason why old and young marry and are miserable nine times out of ten. We may not be beaten with stripes; we may not be starved, neglected, and ill-treated; but we shall find a worm gnawing; we shall find, as Jonah did, the gourd wither above our head, and be ready to faint under the "vehement east wind" and the sun. Happy, thrice happy, is she who by God's mercy is delivered from the snare, though it were with loss of life or limb.

It is a very uncomfortable thing, too, to feel that we are a kind of "chattel" in the hands of our masters. If no one is to interfere in our behalf, what may become of some of us? Does not this doubly prove the need there is for looking into the spiritual affairs of those who speak honied words to us? "What are your means?" is a prudent question of worldly caution; but "Who is *your* master; whom do you serve?" is a greater question of spiritual wisdom, and of ten thousand times more consequence.

Let us not fear to grow old in single blessedness; it is far better than married misery; and if we cannot or will not look to a man's walk and conversation, whether it is with God or Satan, we had much better sit by a lonely fireside, and fulfil some other appointed work, for no blessing goes with marriage unless it is undertaken "in the Lord." May the story of Eliza Jolliffe, by the blessing of God, lead us to great caution in this matter, and may we seek help and direction from the Lord in every step we take.

POULTRY SHOWS.

TORQUAY.—This exhibition took place on the 19th and 20th of January, in the Old Market-place, liberally lent for the occasion by Sir Lawrence Palk. The pens were ranged in a double tier round the whole building under the piazza, and in the centre was erected a spacious tent, beneath which were placed the Devonshire collections; the whole being tastefully decorated with evergreens, and the entire arrangements reflecting great credit upon the Committee and Honorary Secretaries, whose labours had been most incessant.

In the following List of Prizes those classes are omitted in which there were none awarded.

Judges: G. J. Andrews, Esq., Dorchester, and the Rev. Grenville F. Hodson, Chew Magna, Somerset.

CHAMPION PRIZE.—Mr. Thomas H. Potts, Kingswood Lodge, near Croydon, Surrey.

DEVON COLLECTION (*Not less than 3 varieties, nor more than 20 birds*).—*First Prize*—Mr. Wm. Wevill Rowe, Longbrook, Milton Abbot, Devon. *Second Prize*—E. Vivian, Esq., Woodfield, Torquay. *Third Prize*—Rev. St. Vincent L. Hammick, Milton Abbot, Devon.

BEST DEVON PEN.—*First Prize*—No. 149, H. Adney, Esq., Lympstone, Devon. *Second Prize*—No. 95, I. K. Brunel, Esq., Watcombe, St. Mary-Church, Devon. *Third Prize*—No. 35, Mr. R. T. Head, The Briars, Alphington, near Exeter.

OPEN COMPETITION.—CLASS 1.—SPANISH.—*For the best Cock and Two Hens.*

First Prize—No. 1, Capt. Wyndham Hornby, R.N., Knowsley, Prescot. *Second Prize*—No. 3, Capt. Wyndham Hornby, R.N., Knowsley, Prescot. *Third Prize*—No. 8, Mr. Wm. Jos. Square, 4, Cobourg-street.

CLASS 2.—DORKING.—*Coloured.*

First Prize—No. 18, Miss Ann Willcox, Nailsea Court, near Bristol. *Second Prize*—No. 23B, J. F. Pearce, Esq., Lower Slewton, Whimple, Devon. *Third Prize*—No. 23, J. F. Pearce, Esq., Lower Slewton, Whimple, Devon.

CLASS 3.—DORKING.—*White.*

Third Prize—No. 28, Edw. Vivian, Esq., Woodfield, Torquay.

CLASS 4.—CHINA.—*Cinnamon and Buff.*

First Prize—No. 32, Mr. Thos. H. Potts, Kingswood Lodge, near Croydon, Surrey. *Second Prize*—No. 40, Mr. Thos. H. Potts, Kingswood Lodge, near Croydon, Surrey. *Third Prize*—No. 36, Mr. Thos. H. Potts, Kingswood Lodge, near Croydon, Surrey.

CLASS 5.—CHINA.—*Brown and Partridge Colour.*

First Prize—No. 51, Mr. T. Atkins, Babbicombe, Torquay. *Second Prize*—No. 52, Mr. T. Atkins, Babbicombe, Torquay. *Third Prize*—No. 54, Mr. Thos. H. Potts, Kingswood Lodge.

CLASS 7.—MALAY.

First Prize—No. 64A, Henry Adney, Esq., Lympstone, Devon. *Second Prize*—No. 64, Mr. Chas. Ballance, 5, Mount Terrace, Taunton, Somerset.

CLASS 8.—GAME FOWLS.

First Prize—No. 65, Capt. Wyndham Hornby, R.N., Knowsley, Prescot. *Second and Third Prize*—No. 67 and No. 68, I. K. Brunel, Esq., Watcombe, St. Mary-Church, Devon.

CLASS 9.—GOLDEN PENCILLED HAMBURGH.

First Prize—No. 72, Edw. Vivian, Esq., Woodfield, Torquay. *Second Prize*—No. 70, The Rev. St. Vincent L. Hammick, Milton Abbot, Devon.

CLASS 11.—SILVER PENCILLED HAMBURGH.

First Prize—No. 73, The Rev. St. Vincent L. Hammick, Milton Abbot, Devon. *Second Prize*—No. 79, Edw. Vivian, Esq., Woodfield, Torquay. *Third Prize*—No. 76, Mr. Augustus Paul, Adwell Lodge, Torre, Devon.

CLASS 12.—SILVER SPANGLED HAMBURGH.

First Prize—No. 85, Mr. William Kennaway Spragge, The Quarry, Paignton, Devon. *Second Prize*—No. 86, Mr. Charles Edwards, Brislington, near Bristol. *Third Prize*—No. 83, Mr. Augustus Paul, Adwell Lodge, Torre, Devon.

CLASS 13.—POLAND.—*Black, with White Crests.*

First Prize—No. 91, Edw. Vivian, Esq., Woodfield, Torquay. Nos. 87 and 90, equal *Third Prizes*—Mr. J. P. Hine, Thickthorn, near Ilminster, Somerset; Mr. Chas. Edwards, Brislington, near Bristol.

CLASS 14.—POLAND.—*Golden.*

Third Prize—No. 93, Mr. Alexander Pontey, Nurseryman, Plymouth.

CLASS 15.—POLAND.—*Silver.*

First Prize—No. 95, I. K. Brunel, Esq., Watcombe, St. Mary-Church, Devon. *Second Prize*—No. 98, W. G. Vivian, Esq., Singleton, Glamorganshire. *Third Prize*—No. 98A, Mrs. A. E. C. Strickland, Oaklands, Dawlish.

CLASS 16.—ANY DISTINCT BREED NOT SPECIFIED ABOVE.

First Prize—No. 105, W. G. Vivian, Esq., Singleton, Glamorganshire (White Poland). *Second Prize*—No. 107, Mr. Alexander Pontey, nurseryman, Plymouth. *Third Prize*—No. 99, Mr. C. J. Braine, Abbotsley, Newton Abbot, Devon (Black China).

CLASS 17.—BANTAMS.—*Gold Laced.*

First Prize—No. 109, Capt. Wyndham Hornby, R.N., Knowsley, Prescot.

CLASS 21.—BANTAMS.—Any other variety.

Second Prize.—No. 123, Mr. William Nosworthy, 7, Prospect Place, Exeter.

CLASS 22.—PIGEONS.

First Prize.—No. 128, Miss Selina Northcote, Upton Pyne, Devon. (Nuns.) *First Prize.*—No. 124, Mr. W. L. Channing, builder, Heavitree, Exeter. (Almond Tumblers.) *First Prize.*—No. 125, Ditto, ditto. (White Dragons.)

CLASS 23.—GRESE.

First Prize.—No. 133, Mr. William Wevill Rowe, Longbrook, Milton Abbot, Devon. *Second Prize.*—No. 132, I. K. Brunel, Esq., Watcombe, St. Mary-Church, Devon.

CLASS 24.—DUCKS.—White Aylesbury.

First Prize.—No. 136, Captain Wyndham Hornby, R.N., Knowsley, Prescott. *Second Prize.*—No. 138, Edward Vivian, Esq., Woodfield, Torquay, Devon.

CLASS 25.—DUCKS.—Coloured.

First Prize.—No. 139, Mr. William Wevill Rowe, Longbrook, Milton Abbot, Devon. *Second Prize.*—No. 140, Mr. Thomas Blandford, Orchard Portman, Somerset.

CLASS 26.—DUCKS.—Any other variety.

First Prize.—No. 144, Mr. John Moon, Lapford, near Crediton, Devon.

CLASS 27.—TURKEYS.

First Prize.—No. 149, Henry Adney, Esq., Lymptone, Devon. *Second Prize.*—No. 146, Mr. William Wevill Rowe, Longbrook, Milton Abbot, Devon.

MISTAKES AT POULTRY SHOWS.—I would venture to call your attention to the mischief which may be caused by a degree of carelessness in the minor arrangements of our poultry exhibitions, and sometimes tending to cast a shadow of blame upon the judges, which I feel sure they do not deserve. The circumstance which induces me to bring this prominently forward, is the fate of the poultry belonging to a Birmingham amateur, whose readiness in sending specimens has always been conspicuous. This gentleman, Mr. Peters, of Moseley, had a lot of beautiful White Cochinchina fowls disqualified at the Metropolitan Exhibition, not for any fault, but simply because the men employed had placed them in the wrong pens. I presume the judges had but one alternative, and that was to disqualify them, thereby bringing on themselves an imputation of injustice, from which, knowing well their usual *strict impartiality*, I should be as anxious to free them as I am to call down censure upon the habitual carelessness of the inferior officers.

P.S.—You will be pleased to hear that there is every probability we are to be favoured at the next Birmingham Exhibition with a separate class for Black Shanghaes.—WM. LORT, *Ward End, Birmingham.*

[We are glad to have the subject of these mistakes brought to our notice, not only because it will also impress the necessity for more attention upon this point, but because it enables us to state, that the Committee of the Metropolitan Show very handsomely awarded a prize to Mr. Peters upon the facts of the case being made known to them.—ED. C. G.]

JUDGES AND AUCTIONS.—The exhibitions of domestic poultry are now becoming so general, that as each show is over many alterations suggest themselves as regards the judges. I am glad to see you so strongly advocate a change from the present system, for upon that so much depends whether the future ones will be supported. If judges were appointed by the committees, instead of being the mere nominees of one or two, as I fear is too often the case; or if gentlemen judges would refuse to act with dealers, the managers would not risk the responsibility of appointing dealers only; but from our best judges refusing, many are induced to act with dealers, for the popularity, that are not at all competent to judge, without thinking the great harm they are doing such societies.

The quantity of pens to be inspected, I think, might be reduced, by judges for the Cochin, Spanish, Dorking, and Malay, and another set of Judges for the other varieties. The two last years' show at Birmingham were

1851.—Cochin, Malay, Spanish, and Dorking....	349 pens.
Other Varieties of Fowl	314 "
1852.—Cochin, Malay, Spanish, and Dorking....	491 "
Other Varieties of Fowl	527 "

giving a very fair division on these two years' show.

The time for exhibition, I think, could not be reduced to less than four days; one receiving, judging, private view, and public view.

The new feature of public auction might be advantageously introduced as regards the prize pens, for on several occasions I have found them sold a few minutes after the doors were opened to some having superior information; and it would give the owner some chance of claiming his fowl again, and would take very little time at the private view.—AN AMATEUR.

SALES BY AUCTION AT POULTRY SHOWS.—The sale by auction at the Metropolitan Show, taking it all in all, was, no doubt, a miserable affair, and pronounced by many a complete failure: enhancing, in some instances, the interests of a few, but generally tending to the detriment of the majority. It was, however, quite a new feature in poultry exhibitions, and its originality should not, I think, be too hastily condemned, at any rate not *in toto*. It is almost impossible, under the Birmingham system, to obtain even a commended pen, as all the best birds are claimed shortly after the opening of the doors of Bingley Hall, and many of them at one-fourth of the price which they would have commanded under the hammer. I believe that I am expressing the wishes of many influential exhibitors, by suggesting, that only the prize and commended pens be submitted to public competition; and the time selected for the purpose should naturally be when most of the amateurs would be present. A sale of this kind would not occupy more than a couple of hours, and ought not in any way to interfere with the disposal of the other pens, which could be carried on as heretofore.

It appears to me that it would be nothing more than just and fair, both to the exhibitor and the purchaser, to adopt some method by which the owner can obtain the full value of his specimens, and all have an equal chance of obtaining the winning birds, and it was, no doubt, with this laudable view that the Metropolitan Committee conceived the idea of a sale by auction. This bold step towards an improvement might, I think, with the above modifications, produce the desired object, and prove advantageous and satisfactory to all lovers of the feathered race. Should these few lines meet the eye of any of your readers who may coincide with my views, I trust it may induce them to make some further and improved suggestions on this subject, which my homely occupations will not allow me time fully to digest, and of which my want of experience in this new branch of domestic and agricultural industry renders me but an incompetent agitator.

INCOGNITO.

SPANISH FOWLS AT TRURO AND PENZANCE SHOWS.—It is but fair to Mr. Peck, of Wigan, to state that the birds belonging to Mr. Lawrence, which took the first prizes at the above-named exhibitions, were from the stock of Mr. Peck, and not from that of Capt. Hornby. Our reporter was misinformed.

METROPOLITAN SHOW.—In your notice of the Great Metropolitan Poultry Exhibition, in your number for January 20th, you give me credit as the sole originator, which has given Mr. Houghton offence, and wishing to do justice to him, it is certainly due to our indefatigable secretary, to state, and I have pleasure in so doing, that had he not offered the Oval at Kennington, for the purpose, to a friend of mine, and who referred him to me, knowing my desire, with others, to have a London Poultry Exhibition, no show would have taken place this year. Although the Oval had many objections, being the only available place, I immediately consulted my active neighbour, Mr. Fletcher, and soon formed a small, but "*hard-working committee*," to which you have in very kind and approving terms alluded, in consequence of the great success with which its labours were crowned.

Having now given our indefatigable secretary his due praise, he cannot escape without censure for not looking more strictly into the covenants of his lease, which prohibited any exhibition being held at the Oval; thus deceiving all parties, and compelling the committee, at great increased expense and trouble, and to the inconvenience of the exhibitors, to postpone the show for ten days, until the Bazaar could be got ready.

H. GILBERT.

THE COTTAGE GARDENER'S PONY.

I SEND you the enclosed notes for an outline of an introductory paper on the subject which I proposed to myself. You will see that it prepares the road for sundry and singular disquisitions on the economising of draught; the education of animal muscular power; the natural, or acquirable adaptability of a given animal (or too probably a bought, and dearly bought one) to certain tasks; the probable cost of keep; and the amount of profitable work to be calculated on as a set off; the man's wages according to the time he is occupied in pottering about the stable, &c. I believe I have read nearly all the books on horse-flesh easily to be come at, and my general impression is that they are too ambitious; the authors mount with their subject; they get on the high horse. My friend, Martin Doyle, appears to be so much of the same opinion with myself, that in his little work for small farmers, an invaluable manual for cottage gardeners and farmers, he entirely dissuades against keeping any horses at all.

If I understand rightly the requirements of cottage gardeners and small occupiers, such as would be likely to be edified by my lucubrations for cottage gardeners, I should be inclined to lay down the following propositions:—

A small allotment, of say from five to twelve statute acres of land, either your own, or taken in a good state of cultivation on a fair lease, or taken cheap for a long lease, for improvement, ought to afford a great deal towards the comfortable enjoyment of a family, and should provide a fair remuneration for the undivided attention of a clever labourer; or, if his own, should be a little competency for him (such small allotments were the very earliest *freeholds* that ever existed). I once wrote a paper on their great antiquity; throughout the history of the Egyptian soldiers and priests; the Roman soldiers (whose "quatuor jugera" (four yoke-lands) were synonymous with peace, retirement, independence); the Saxon half-sacred Boelands; the small freeholds of the Belgians, &c.; and our own old English forty-shilling freeholds, which I suppose may, at the time of the defining of their now nominal rental, have been valued at about five shillings per acre. This by-the-by; for in order to make out my case, I had to go into the history of the feudal system, as contradistinguished from the freehold; and to trace through the one the progress of men living in connection with cities, as civilised men; and along with the other, the more picturesque, primitive life of the shepherd kings of all ages; from the time of the great King of the Vale of Gerar, through the proud but humble Etruscan nobles, who only held in tenure, and let to their vassals, whose feeling was

"Vita que mancipio nulli datur; omnibus usu."

(Life itself is not given in freehold; but only on lease.)

and thence down to the very Affghans, Caffres, and Thibetins of this day, who are mostly feudalists. You see this is too long and unmanageable a subject to bring in; I only allude to it now, thinking it might interest you, and to shew you that I have looked into my subject: so now to return to our mutton.

Then, I suppose our cottage gardener, of this degenerate day, to employ a man, for hire, to do what his prototype in ancient days did with his own hands, unless the sad fellow had got hold of an unfortunate slave in the wars. But, as the keep of a man-servant, and his wages, is a serious addition indeed to the expense of the small occupier, who, unless a clergyman, or small freeholder, will probably have to pay a good round sum in rent and taxes, a horse, super-added to a servant, and a fine London carriage added to the horse, and then, unless we take care, farewell to rural simplicity and chauntings of "Happy the man whose every care a few paternal acres bound."

The story then becomes, "It is very pleasant living in the country, but then it is so very expensive." Just so; if people will take down with them into the country all their miserable cockney habits and stylish notions. If you go to Rome you must do as they do in Rome; and if you go to live in the country, you are not to do as they do in Rome, or in London either; but as as they do, or ought to do, and used to do, in the country. This, then, brings me only just to my starting point, viz., that an equipage for the country need not be exactly the same as one for London; nor the country servant as fine a fellow as the London servant.

You might as well try to have your own dairy and your own poultry-yard in Spring Gardens or Park Lane.

But as for the better class of your readers, who keep their carriages and servants, and live in the country "en prince," they will have no need to look into THE COTTAGE GARDENER for information how to save a penny in their stable expenses. I purpose not to write for them. Now you have my ideas, and some little sketch of my plan, which very likely I shall not adhere to after all! Do you think the "diggings" will be worth working out? And can you tell me how often I might be allowed to appear in my stable dress, if I continue in stable mind? "The Cottage Gardener's Horse" would, perhaps, be better than "Pony." And I must be anonymous.—VIBGYOR.

[Your programme is too good to be lost. Write as often as you like; the oftener the better.—ED. C. G.]

PHEASANTS.

[If our readers will refer to page 135 of our last volume, they will find a paper under this title, and with this appendage, "To be continued." We have no excuse if any one enquires—Why was it not continued before?—ED. C. G.]

WHEN the chicks are about ten days old they will require a larger range than that which the net protection affords. To accommodate them, draw it away from the coop about three inches; the little things will soon learn their way in and out, their increasing strength and activity of limbs enabling them now to reach the shelter of the coop, or front, quickly on the alarm of danger; the tit-bits remaining, in the mean time, secure from pillage, out of beak's reach from the elder birds.

The proper time to place the youngsters away from their foster-parents into the pheasantry they will point out for themselves, by a natural weaning and inclination to roost away from the hen at night; or otherwise they become too large to gain admittance between the bars of the coop. When allowed the society of their elders, the same treatment adopted for the old birds will serve for them; namely, barley and wheat alternately, with the supply of other et ceteras advised upon when I described the pheasantry. I lay particular stress upon the item, *turfy-ant-heaps*—Procure these if possible; you thus provide grass, eggs, and insects—food, exercise, and amusement all combined. A race-course became the medium for an inexhaustible supply of this article to us. I wonder how many wheelbarrow-loads of this nature our late parish clerk would have the hardiness to confess to! Ah! Jones! Jones! fate says, press on; nerve, brace, think, and hope for the future; treat by-gones as by-gones. Still, there are objects, bright spots of the past, upon which one loves to memorise. Oases in the desert, as it were, which one loves to recall for the mind to dwell upon. "Our Will!" Now I always maintained an indistinct idea of this domesticated sobriquet, that this household apology for a name meant, William Jones. Be this, however, as it may—Jones! Jones! when shall I look upon your like again? You, the concentrated balm and nard of human kindness; you, of the burly form and rubicund face, with the large and the noble heart! Surely we should be a happier race of men, could we muster—could we fill the world with Jones's! prototypes of yourself, my good and honest old friend!

I would not advise an attempt to indulge the *Golden Pheasants* with their liberty; unless, peradventure, a considerable amount of time and patience are at command, and then even the observation only applies to the male birds; once let out the hens, that is, when they have arrived at the days of discretion, and you may call, or whistle for them in vain. "She's gone!" is all that will remain for you as a consolation. The *Silver* and *Common* varieties, of both sexes, may be allowed this privilege (excepting during the laying season), and premising that a point of feeding is adhered to, at stated intervals, three times a-day, *within* the pheasantry, securing them there at the last meal. The lock and key is their true, if not the most natural safeguard.

To distinguish the male from the female, it will be necessary to wait until they moult, when the masculine gender become mottled with their gaudy plumage. The

Gold and Silver breeds arrive at their full plumage the following autumn, and the common pheasants the first winter. We have killed the Silver breeds for the table on grand occasions; they are white in the flesh, but dry eating. The Golden birds were too precious to be experimented on in this way, though I have no doubt they would prove infinitely worse in this respect.

The snowberry (*Chiococca*) should always be allowed a position where pheasants are the order of the day. I have often wondered how it is this shrub has not found its way into preserves more largely, being, as it is, so well calculated for undergrowth, independently of its fruit, which the pheasants are uncommonly fond of. Inquiries are often made for those shrubs which are most applicable for undergrowth, in cases of neglected shrubberies, where trees are growing under, or rather over bare poles; circumstances resulting from that truly grasping-the-substance-to-swallow-the-shadow principle, which inevitably ensue by consequence of a too prevalent disposition, which will not allow a judicious thinning out the young trees, &c., betimes. I could cite a case, though not exactly a literal instance of what I am hinting about, where this shrub was planted, and it formed an almost impenetrable jungle; where, not only pheasants, but the poultry also, were continually feasting upon its long succession of delicate white berries.

I find a difficulty to get away from this eating subject, though, when I consider it as being the chief element of existence, I compose myself comfortably and prosy, with pressing another feature upon the subject—a parting thought for my favourite Dorkings. There is a vegetable, which, at least so the doctors say, is wholesome to a degree; but, it must stand confessed, it is not *fashionable* to eat.

“Away! base bulb! Oh, horror! say my young ones,
Ere you go courting, could you fancy—Onions?”

I am positive you could not. Poultry are not so particular; they are by no means averse to chopped chives, which I cultivate on purpose to mix with their barley-meal in the spring time of the year; and, withal, it is a very wholesome addition. Chives may be grown in any out-of-the-way corner. The green tops are the parts which are used, and of them it may be said, “cut and come again.” Our poultry partake of barley-meal once a day, at two o’clock, moistened with fresh milk, when potatoes, or any vegetable remains from the dinner-table, are mixed with it, including, three or four times a week, some pounded egg-shells. Hard grain should be given in the morning; indigestible suppers are bad for man, and it is equally certain that barley-meal or other moist food is better for fowls to sleep on.

UPWARDS AND ONWARDS.

(To be continued.)

A USEFUL GARDEN SPUD.

ONE very useful tool I can strongly recommend to persons having an orchard, is a three-inch *socket* chisel, fastened to a seven-foot ash handle, with an iron ferrule put on the handle to prevent it from being split, to cut out robbers and cross branches, &c., from trees in an orchard. I drive the handle with a wooden mallet.

I have tried several tools recommended by some gardeners for heavy clayey land, and had them made to weight, shape, and size, but found them *too heavy*. The same tools made lighter in weight, and having more steel, would be more handy, and more useful; this should be recommended and borne in mind.

I have had a failure in *gutta percha hose* for watering my orchard from the liquid-manure tank. It was left out for a night or two in the orchard, and some liquid in, and it collapsed and spoilt.—I. B.

W.

POULTRY DISEASES.

EXHIBITION FEVER.

“H. H. wishes to know the name of a disease that her fowls caught at the Birmingham Poultry Exhibition. It is

violent and sudden in its effects, turning the comb and legs black, and drawing the feet up, as if with cramp; the effluvia immediately after death is horrible. She wishes, also, to know of a cure. There is no running at the nostrils, and it is not, therefore, roup, though the eyes are sometimes affected, but not generally, and they do not make that kind of sneezing sound which is always a sign of the roup.”

[The symptoms mentioned are those of a fever of a putrid or typhoid character, as far as I can pronounce from so short a description. In the advanced stage which is described above, I should consider the cases hopeless; all that can be done is to prevent a disease of so fatal a character extending to the remainder of the yard. Typhoid fevers are produced in human subjects by over-crowding, want of ventilation and cleanliness, collections of decaying refuse, as dung, &c., and unwholesome food and water. I should attribute the disease to one or more of these causes. The highly-stimulating and unnatural foods on which fowls, particularly those fed up for exhibition, are now kept, must tend to produce an irritable and inflammatory state of the system which predisposes greatly to these diseases. Such conditions of body are very apt to be followed by a reaction, which runs rapidly into low fevers of a typhoid character: thus a drunkard dies with delirium tremens, and an overfed brewer's drayman sinks under an accident from which a healthy countryman would get well in a week. What I should recommend in this case would be, a diligent inquiry for the predisposing cause of the disease, and its immediate removal. I should also advise every fowl to be taken away on the first symptom of illness, and the employment of lime-wash over the whole interior of the poultry houses, the wash being made with freshly-slaked lime, not with whitening. Should these means not prove effectual, I should be glad of a more particular account of the disease and of the circumstances, as to food, water, &c., under which the fowls are placed.—W. B. TEGETMEIER, *Tottenham*.]

[Is not this disease parallel with the old Gaol fever, which arose from long, unnatural confinement in a cell, among fellow-creatures crowded under one roof in similar cells? If so, would not prevention be better than having to cure, which prevention would be a shorter period of confinement?—Ed. C. G.]

APOPLEXY.

“A Subscriber” writes thus,—“Having this morning lost a fine two-year old Cochinchina Cock in the following sudden, and to me unaccountable manner; and having likewise suffered a similar loss about this time last year, I write to request you to inform me whether male birds of this breed are liable to attacks similar to those under which my favourites have sunk.

“I myself saw the bird about ten minutes before the attack came on. He was then out in my yard with two pullets, and was answering the call of some hens, from which he had been separated a few days. A small shrubbery adjoins my yard, and as I was walking past it, I suddenly heard the suffocating cry of a bird. I turned towards the spot from whence the noise proceeded, and found the cock lying on his side in the agonies of death. I had him immediately opened, but with the exception of the neck veins in the vicinity of the head being charged with black coagulated blood, nothing wrong could be discovered.”

PARALYSIS.

“A Lover of all that is handsome,” says:—“Last Saturday one of my pullets was full of life and quite well, and on Sunday morning was found lying on her back, her feet cramped, and very hot and feverish, refusing all food. I kept her warm, and gave her oil, which purged her, and allayed her fever. An old bird-fancying servant thought that she was full of eggs, and was too fat to lay them, which appeared true enough, for after the oil had worked her, she laid one egg. On Wednesday another, and to-day (Sunday) the third. I kept her bowels open, and fed her less. Her appetite is good, her comb red, her eyes bright, but all power of motion in her legs is gone. There is no appearance of cramp in her feet, but they are quite powerless. She looks quite well when sitting in her basket of hay, but if you lift her up, and put her down again, she falls on her head and side. Her two first eggs were rather soft-shelled.

I gave her some pounded oyster-shells, and the third, this morning's, was quite perfect. What can be done for her?"

[The old story; if poultry are fed with aldermanic diet, they must of necessity be subject to aldermanic diseases. The case of the pullet is evidently owing to a slight effusion into the skull, which has produced not apoplexy, as in the previous case, and in the case related at page 298, where the effusion of blood was very considerable, but paralysis of the lower limbs; nothing can be done in such a case. It is just possible that the effusion may be absorbed, and the bird partly recover, but this is very improbable. She should be kept perfectly quiet, and fed on plain vegetable food. When she dies, I should feel obliged if the owner would cut off the head, about five or six hours after death, and forward it to me by post, as in that case I should be able to test the correctness of my opinion. I quite agree with an opinion expressed by Mr. Baily, that *boiled* cabbage is worse than useless, the greener parts of the leaves certainly are not digested; it may be good as a medicine diet, but not as food. —W. B. TEGETMEIER, *Tottenham*.]

HONEY HARVEST OF 1852.

I SEND you a note of my last season's doings in bee-keeping. By "net" I mean the weight of the honey, bees, and comb in stocks, and of the honey and comb in supers and glasses. I may as well state that the weather in our parts (North of England) from April to the end of June was wretched—cold, wet, and windy; in July, magnificent; in August, moderate.

No. 1: SWARM OF 1848.—The net contents of this hive, in September, 1851, were 24 lbs. On 24th of May the hive swarmed: no second swarm came off. On 7th of August I took a glass, net weight 7½ lbs., and on the 22nd of September fumigated the hive, and carried off 25 lbs. of honey. *The swarm* from this hive, which had to be fed constantly through June, weighed, on the 26th of August, 27 lbs. net.

No. 2: SWARM OF 1849.—In the beginning of June most of the drones and drone grubs were turned out and destroyed, and towards the end of the month a few bees died from starvation. On 3rd of July the hive swarmed; no second swarm came off, and on the 20th a young queen was thrown out. On 2nd August, I took a small glass, 3 lbs. net; on 6th of August, another small glass, 3½ lbs. net, and a box, 2 lbs. net. On 26th of August this hive weighed 25½ lbs. net. *The swarm* from this hive weighed, on 26th of August, 25 lbs. net.

No. 3: SWARM OF 1850.—In the beginning of June most of the drones and drone grubs were turned out: in the middle of the month the bees began to die in large numbers, and I was obliged to feed liberally. The hive did not swarm. On the 12th of August I took a small super, 4½ lbs. net; and on the 26th another super, 8 lbs. net. On the 26th of August this hive weighed 20½ lbs. net.

From this it will be seen that from three stocks I have taken 28½ lbs. of honey in glasses and supers, and have had two swarms, the net contents of which amounted, on the 26th of August last, to 52 lbs.—in all 70½ lbs., or an average of 23½ lbs. for each hive; this, at a shilling, or even tenpence per pound, makes each hive a source of considerable annual profit, even in a poor season like the present.

What a pity it is that we cannot induce our cottagers to keep bees in greater numbers than they do; there is really no mystery about it—a slight knowledge of first principles, and a little care and cleanliness, and "there you are." Flourish is of no use; the picturesque is a sham. I believe that the improved cottage system is the simplest and the best; and I can for myself safely say, that I have derived more pleasure (to leave the profit out of the question) from bees than from any other amusement; though, when I *do* get stung, I present more the appearance of a prize-fighter than an ordinary mortal. It is of no use beginning without some knowledge of the habits of bees, and a fair stock of apparatus. The greater part of the apparatus any intelligent cottager can make, and even if he cannot, I am sure £2 or £3 of his hard-earned savings would be well invested in providing what is necessary. K.

PRESERVING SPECIMENS OF ANIMALS.

(WE have been favoured with a manuscript written by the late DR. LATHAM, so favourably known by his "History of Birds." We are not aware if it has been published previously; but even if it has, we are quite sure that many of our readers will be glad to know the preservative process adopted by so distinguished a naturalist.)

THERE are two methods of preserving birds or other animals, the one by preparations which are antiputrescent, the other by an heat regulated in such a manner as to cause the aqueous parts to evaporate, while the flesh becoming thus dry nothing is left that can grow putrid, and the animal is immediately preserved without further trouble. Both these are liable to some exceptions, yet both will answer well with care.

It must be premised, in regard to the subject to be prepared, that it be as free as possible from apparent injury in the killing, such as the loss of many of the feathers on the parts most in view, or the feathers being bloody, &c.; though if a wing or a thigh be broke, or even one side only disfigured, it will not much signify. But if the bird can be had alive, being caught in a net or otherwise, it will be best. In this case, one way of killing it* will be by confining it in a towel, or other means to prevent its fluttering, whilst a knot is made in a piece of fine twine, which being put round the neck and drawn tight will presently strangle the animal. The feathers must be raised up where the twine is applied, lest it may rumple them. As birds are often obliged to be transported to some distance before they can arrive at the hands of the person who is to preserve them, it may be not unworthy of notice that a bird will keep longer free from putrefaction if the intestines are not drawn. They will often keep fit for preservation for ten days in winter, or even much longer in hard frosts, but in summer a much less time, according to the heat of the air. The bowels, therefore, should not on any account be taken out, except they cannot arrive at their journey's end within the above time; in this case they should be extracted by an incision in the belly, without soiling the feathers if possible, and the cavity filled with wool, moss, tow, or the like, sprinkling here and there some pepper and camphor mixed together, or pepper alone, also putting some in the mouth and down the throat. But if it is possible to send them to their place of destination within a moderate time, nothing is to be done, except in each case the feathers, especially those of the neck, are to be laid smooth; the whole bird to be laid at length, or, if more convenient, the neck to be doubled back with care under one of the wings. Each bird to be wrapped separately in clean paper, to be packed up with hay, &c., tight enough to prevent rubbing in the carriage. Another thing not to be omitted is, that as many birds have remarkable coloured irides (or circles on their eyes), it will be best to remark them at the time of their being killed, or soon after, as their colour will disappear in a few days. No more needs be done than to draw with a pencil on paper the size of the pupil and iris, and remark the colour beneath it, lest the memory should not furnish a sufficient idea of it afterwards. The use of this caution is that the eye may be imitated by painting, as mentioned hereafter.

Suppose a bird to have arrived as wished for. Drive two long pins or nails in a table or dresser, wide enough to admit of the neck of the bird, and to rest against them at the shoulders; two more are to be driven through the flesh of the thighs into the board, to keep them apart; by these means the bird is kept steady. Then open it from the vent to the breast-bone with a pair of scissors,† being careful of

* Small birds are killed by pinching them very tight with a finger and thumb under each wing, which, preventing them from breathing, soon finishes their life.

† I now open it, on the side opposite to the sight, under the wing, all the way down, and, dissecting back the skin over the breast to the other side, I take out the breast-bone, flesh and all, as well as the contents within, and, sewing it up again, stuff the cavity with the stuffing. This I have adopted, as I think it easier than any other; and if the edges of the skin are drawn back, as fast as dissected, by crooked pins, fastened with a string to each, and a loop to tack them down with, the danger of bloodying the feathers on the breast will be entirely avoided. When all is taken away that can be, I thrust up each thigh through the skin that

wounding the intestines; then let all the contents be drawn out with the fingers, if a large bird, or a pair of forceps, if a small one. Let some of the antiputrescent mixture be put in, and a layer of wool, cotton, or any proper substance, be stuffed upon it, and then another layer of the mixture, and so on till full, and rather ramming them in than otherwise; which done, continue the opening, already made, up the breast quite to the throat, and, stripping the skin back on each side, cut off the flesh entirely from the breast-bone. Then take a needle and thread, and, by small stitches, unite the opening you last made almost to the place you began it, and putting in some of the mixture as above, with any soft stuffing to fill out the breast to its usual size, or rather more, continue then the stitches to the vent, and replace the feathers, and this part is finished, the which, if carefully done, it will not be known that the bird has been opened at all. Open then the eye-lids, and introducing a strong needle within the upper lid, on the outside of the globe of the eye, push it into the back part as far as you can, and, carrying the point upwards, let it come out through the pupil. You may, with the needle in this situation, pull up the whole globe from the socket, if you hold the lids with your fingers to prevent their bursting open. When they are thus emptied they may be filled *from without* with cotton and some of the antiseptic mixture; or, *what is better*, by making a hole within the bill upwards on the outside of the upper beak to communicate with the orbit (which in small birds, especially, will be found the best way), through which the stuffing may be introduced. The eye then is to be put in upon this stuffing, for which purpose half of a common black bead (it being split) is to be placed in the socket on the stuffing, and covered with the eye-lids as in a natural eye. If a coloured iris is wanting, it is to be painted with water-colour or oil,* and afterwards varnished, which will give it a very good lustre, perhaps not quite so well as enamel, but a very good substitute. Some of the mixture ought also to be thrust down the throat, but this with very little, or rather no stuffing. An opening is next to be made in the mouth, through the palate upwards into the brain, and some mixture and cotton thrust into that cavity as well as the rest. If the bird has exceeding fleshy thighs, the skin on them may be opened as in the breast, and the flesh taken off, to be sewed up again and stuffed as before; though this is scarce ever necessary in small or middle-sized birds, as the mixture will sufficiently penetrate the flesh without that trouble. Nothing now remains but to put the bird in a suitable position to dry; for which purpose let a piece of board of a proper height be placed upright upon the edge of another placed horizontally, and a perch placed in the upright one if the bird is to stand so. Then run a stiff-pointed wire down the throat into the body,† letting it come out at the side under the wing of the bird, which is to be placed from the eye; this part to be bent and stuck into the side board at the height necessary, whether the bird is placed on the perch or the ground. A sufficient length is to be left for the length of the neck, the end of which is to be thrust upwards into the skull, by means of which wire the neck may have any direction given to it. Wires also are to be put through the wings to support them, and other parts, as may be necessary. The bird thus supported is to be set by for some weeks in order to grow stiff, and the mixture to penetrate when it is done.

The mixture is pepper 6 oz., camphor 1 oz., alum 2 scrup., common salt 2 scrup.; powder separate, and mix. †

covers it, and cut off all the flesh from it also; in general there will not want any stuffing to fill up its place, but it may be done if thought necessary, as also some of the antiputrescent mixture added.

* I have left off oil colour, for I find it stands well enough if the colour is laid on with gum-water and well varnished, as the oil is so long drying.

† I find it best to place the wire before I put in the stuffing, as it is difficult to thrust a wire, however pointed, through the stuffing without bending.

‡ I now add brimstone powdered, or flowers of brimstone, equal weights of that and the mixture if the bird is to be dried in the oven, or if not, only one-third.

(To be continued.)

STONES ON LIGHT SOILS CONDUCE TO FERTILITY.

It is a common practice with the farmers in my neighbourhood to employ women to pick stones off their light and gravelly soils. The plan is one of doubtful utility. Stones intercept the force of the sun's rays, check evaporation, give fixity to the soil, and retain much moisture under them. A stone will often nourish four or five blades of corn, in consequence of its shade and moisture, and the spot round it is brighter and greener than where stones are absent. An intelligent friend of mine, who cultivates about 1000 acres, has carted stones on to some of his lightest soils with excellent effect.—S. P. RUSHMERE.

TO PRESERVE EGGS FOR SETTING.

PLACE a box in a dry place in your kitchen, not too near the fire; partition the box, so as to hold separately the different eggs of the various sorts; let bran be well dried in the oven, and put into the partitions, and cover the eggs with the bran as they are placed in; and this should be done soon after they are laid. In this manner they will be prolific from a fortnight to three weeks in the winter. Always mind to place the thin end of the egg downwards, so as to stand upright. While your hens are laying, feed them well twice a week with pork-butchers greaves; I mean those that cut like collared brawn; not tallow-chandlers' greaves, for these are worthless for poultry. Your chickens must be fed occasionally with hemp and canary seed, and some meat cut very fine, but not too much, or you will lose them. They are apt to get the cramp in their legs in the months of March and April, especially the Spanish chickens. Nothing but good feeding and warmth will bring them round. Set your hens in a dry, warm place at this season, or you will find your mistake out when you look for chickens.—J. AMPHLET, *Walsall*.

CALIFORNIAN AGRICULTURE AND HORTICULTURE.

AFTER hearing so much about the golden harvests of California, it is refreshing to find that the more permanently productive "diggings" are not less promising. The following, written by an American, is dated San Francisco, November 30th, 1852:—

The opinion is quite prevalent in the States that the resources of California consist almost entirely in her mineral wealth, and that but a small portion of the State is adapted to cultivation. There is no greater error than this. So far from the soil being as barren and sterile as it has been represented to be, nearly the whole State possesses a wonderful fertility and adaptation to easy cultivation. To be sure, much of the country in the latter part of the dry season appears to be incapable of producing anything, yet this very same soil, if sowed with wheat or barley soon after the rains set in, yields the most wonderful crops. However, a few facts, showing what has been produced here already, although this branch of industry is still in its infancy, will give a much better idea of the Agricultural capacity of California than any mere description could give.

Through the enterprising and the most indefatigable industry of Colonel Warren and Co., of Sacramento, an Agricultural Exhibition was held last month in that city, at which some most astonishing productions of the soil were exhibited. The following are the weight and dimensions of some of them.

Squashes weighing 108 lbs., and six feet eight inches in circumference.

Pumpkins weighing 110 lbs., and seven feet in circumference.

Watermelons weighing from 36 to 44 lbs., and from 2½ feet to 3½ feet in circumference.

Beets weighing from 30 to 40 lbs., and 40 inches in circumference, and one beet 7½ feet long.

Cabbage weighing 35 lbs., and 45 inches in circumference.

Turnips weighing 19 lbs., and 24 inches in circumference. Potatoes weighing 4½ lbs., and several sacks of them which averaged 3 lbs. each.

Onions weighing 4½ lbs., and 22 inches in circumference. Corn 30 feet high, from a field of five acres, averaging 50 bushels to the acre.

Samples of wheat averaging 50 bushels per acre, and barley averaging from 75 to 100 bushels per acre.

Incredible as the above account may seem, it is none the less true, for most of the products mentioned were seen and examined by your correspondent, as much to his surprise as this description of them is to that of your readers.

TO CORRESPONDENTS.

*** We request that no one will write to the departmental writers of THE COTTAGE GARDENER. It gives them unjustifiable trouble and expense. All communications should be addressed "To the Editor of the Cottage Gardener, 2, Amen Corner, Paternoster Row, London."

ERROR IN THE PRICE OF No. 226.—Several correspondents have written to complain that they were charged fourpence for No. 226, and they may well complain, though not of us, but of our printer, and their booksellers. It is quite true that, after finishing the stamped copies, which are charged fourpence, the printer for a few copies omitted to change the 4 for a 3, and the booksellers, in some instances, have consequently charged fourpence for those copies. This they ought not to have done, for if they had looked at their invoices they would have seen that those copies were charged to them as retailed at threepence. Every subscriber is entitled to have his over-charged penny returned.

SAPONARIA CALABRICA CULTURE (Subscriber).—If you sow the seeds of *Saponaria Calabrica* any time in February, in a hotbed, it will vegetate in twelve or fifteen days, and be fit to move to a cooler place in three weeks from the sowing of the seeds. If you have a good stock of plants of it in single pots, and you are pinched for room, you may plant out the young *Saponarias* close under a south wall, by the middle of April, and four inches apart. They may remain so till early in June, or any time in May when the beds are free from the autumn-sown annuals. Thus treated, the *Saponaria* begins to bloom a little after Midsummer, and will go on slowly and flowering freely until stopped by the frost. It will not bear to have any other plant with it. *Saponaria ocyroides* is a very pretty rock or border plant, but one of the most difficult to manage for an amateur. You had better have nothing to do with *ocyroides* for a year or two, unless by way of experiment. By that time we are almost sure you will be able to manage any plant, however difficult to grow, and that will be time enough to think about *S. elegans* and *lutea*, two which we never recommend for general use.

GREENHOUSE CLIMBERS (S. E. S.).—Your "tubs," about a foot square, are only the smallest sized boxes that one would use for a Scarlet Geranium, and hardly that. They will never do to plant any good climber in. Have you never been in the conservatory of the Horticultural Society? They went to the expense on purpose to convince amateurs like you, that small boxes, troughs, or tubs, are entirely useless to grow climbers in. *Mandevillea*, for instance, would fill a tub a foot deep, as much in width, and at least a yard long, in one season; flower in it the second year; and, perhaps, the third, with abundance of liquid manure, but after that you would have nothing but red spiders from it—from sheer starvation; and a *Mandevillea*, with less than one hundred flowers open is hardly worth looking at. The new *Tropæolums*, which Mr. Beaton mentioned lately, are the only plants suited for flowering in your tubs in winter; and *Acacia prostrata* of the nurseries, with the smallest kinds of the old *Kennedy* breed, spoken of by Mr. Fish more than once, for summer.

WHITE BEDDING PLANT (A Subscriber).—"A bed is to be planted with three rows of *Tom Thumb* Geranium next the outside, and the middle with *Salvia patens*. What is the best white flowering plant to divide the scarlet from the blue, and be in the proper degree of height between Tom and this *Salvia*?" Here is a concise letter, and much to the point, and from a lady correspondent. To be able to subdue the powerful effect of three rows of *Tom Thumb* to the right degree, you must use a large white flower, and allow the white to occupy about two feet of space. If you can do that, the bed will be all that one could wish. The *Shrubland White Petunia* is the plant we would use, and we would keep it on a little slope, by a little training and pruning, all the season. Any good white *Petunia* will do, however, except the old *nyctagyniflora*, which is too strong for this row.

SHANGHAI EGGS (A Lady).—Mr. Sturgeon never sold an egg from his fine stock, and probably never will. Buying eggs to breed from is but a lottery. "Long legged, and not sufficiently feathered," are two points which do not belong to the true qualities of a Shanghai fowl. Pray wait till the beginning of March, and take the first number of "The Poultry Book."

FLOWER GARDEN PLAN (An Amateur).—Our space is engaged for February and March, and your plan will come in April, with your own valuable and practical illustrations of it, &c.

PORPHYROCOMA LANCEOLATA (Amateur, Dublin).—Treat it in all respects as you would *Justicia carnea*, or *Aphelandra cristata* in a young state. The best hardy *Fernis* to plant along a running stream are *Pteris aquilina*, *Osmunda regalis*, *Asplenium Tricomane*, and the different *Aspidiums*, as *Filix mas*, *F. fœmina*, &c.

CLIMBING ROSES (J. B. W.).—Your climbing Roses have done remarkably well for the first season. Prune them next March, as follows: *Felicite perpetuelle*, ten feet high, prune back to four feet, and the weakest shoots to three feet. *Maria Louise* and *Rampant*, five feet high, prune down to the very bottom. The same kinds, eight feet, for arching over the walk, prune to two feet.

GREENHOUSE AND VINERY (W. D. A.).—You will see this has been alluded to to-day by Mr. Fish, and will meet with more attention.

BALSAM SOWING (Reading).—Sow the seed not earlier than the end of March, or the beginning of April, in a slight hotbed, and harden the seedlings off to greenhouse or cold pit treatment early, if you wish to have fine flowers. Most likely we shall allude more in detail to this subject before you commence operations. The sooner you commence before April the more trouble will you have to obtain good flowers and bushy plants.

IMPREGNATION OF EGGS (*Quercus*).—The egg is certainly impregnated whilst a mere yolk of very small size in the ovary; and as to the time before being laid, it is quite demonstrated that this may be as long as three weeks. The following letter, from a poultry-keeper of eminence, is, in fact, an answer to your query, though unintentionally:—"With reference to the opinion of 'B. P. B.,' in the COTTAGE GARDENER of the 27th of January, my experience would lead me to the belief that three weeks is not long enough to insure purity of breed from a hen, who had been with one cock and then removed to another. My reason for suspecting that chickens from the eggs produced from the second cock might (I do not say will) possess some of the strain of the first, consists in the fact, that I once separated a hen from her cock, and an egg laid on the 23rd day of her separation produced a chicken. A friend of mine also tried the same experiment, and he found the egg of the 20th day was hatched.—K."

BLACK-BREADED RED GAME FOWL (Raymond).—The queries of "Raymond," as to the points of merit in the black-breasted red game fowl, are best answered by a reference to Mr. Thomas Roscoe's description, communicated to the Rev. E. S. Dixon, and published by him in his work on Ornamental and Domestic Poultry. Mr. Roscoe, it will be remembered, had the charge of the late Lord Derby's birds, which, being long considered as the best blood of their race, were emphatically termed the *Derby Reds*. "The cock is a fine round shaped bird, with white striped bill; daw eyes and fiery; round and strong neck; fine, round, close feathered hackle, with feather points to shoulders; short, stiff, broad back, close feathered and hard; tail, long and sickled, well tufted at root; wings, round and well prolonged, so as to protect the thighs; breast, broad and black; belly, small and tight in the pinions; thighs, short and thick, well set to the body; legs, long and white; smooth insteps; claws, strong; nails, long and white; the comb of a stag is rather large and red before being cut; weight, about 5 lbs. The hen is of a fine round shape, in colour resembling a partridge, with daw eyes, white legs, toes, and nails, and large and fanned tail." We have not observed prizes given during the past year to any pens of birds that did not match in colour as well as other points, and their difference in this respect would be justly considered as disqualifying them altogether.—W.

VINES IN POTS (B. H.).—We know of no work upon the subject exclusively.

FEATHERS (Cochin).—We have some engraved, and shall begin publishing the series, probably, next week. They will not be coloured, of course, but they will instruct you in all the distinctions you require explained.

GOLD FISH (A New Subscriber).—Can any of our subscribers inform us whether there is a publication instructing how gold fish should be treated when kept in a glass vase?

POULTRY (An Amateur).—The best fowls you can keep without fear of encroaching upon your neighbour are the Shanghai. The Buff and the White are the sub-varieties most in request.

POULTRY JUDGES (A Well-wisher of Poultry Exhibitions).—We do not think the objection should be carried as far as you suggest. Every judge has a preference for some strain; but we do not think that he dare give a prize to an inferior bird merely because it was of that strain.

GLOSSARY OF POULTRY TERMS (W. W. W.).—We will see what can be done in the way you suggest.

SPACE BETWEEN RASPBERRIES (Nemo).—In so narrow a space as three feet between your rows of Raspberries, nothing will grow so well as Spinach in a drill up the centre. None of the crops you mention will do well there. If your ground is light and well-drained, plant your *Ash-leaved Kidney Potatoes* immediately, during open dry weather.

FOULSTONE'S BUDDING INSTRUMENT (John Robinson).—We have applied ourselves, and can obtain no reply. An advertisement from the makers will, perhaps, appear one of these days.

NAMES OF PLANTS (A. M. L.).—Stove plants—No. 1, *Bromelia*, but cannot name the species; 4, *Zygopetalum Mackayi*. Mesembryanthems—No. 1, *M. inclaudens*; 2, *M. blandum*; 3, *M. aureum*; 4, *M. coccineum*; 5, *M. acutangulum*; 6, *Linum flavum*; 7, *Chrysocoma comarea*? 8, *Iberis semperflorens*; 9, *Cheiranthus mutabilis*, var. *longifolius*? The rest unknown to us.

LONDON: Printed by HARRY WOOLDRIDGE, Winchester High-street, in the Parish of Saint Mary Kalendar; and Published by WILLIAM SOMERVILLE ORR, at the Office, No. 2, Amen Corner, in the Parish of Church, City of London.—February 10th, 1853.

WEEKLY CALENDAR.

M D	W D	FEBRUARY 17-23, 1853.	WEATHER NEAR LONDON IN 1852.				Sun Rises.	Sun Sets.	Moon R. & S.	Moon's Age.	Clock bf. Sun.	Day of Year.	
			Barometer.	Thermo.	Wind.	Rain in In.							
17	TH	Small Eggar Moth; bushes.	29.858	-29.558	56-37	W.	—	12 a. 7	17 a. 5	2 30	9	14 18	48
18	F	Orange Upperwing.	29.737	-29.596	46-27	N.W.	—	10	18	3 34	10	14 13	49
19	S	Spring Usher; dry leaves.	30.018	-29.783	39-23	N.W.	—	8	20	4 34	11	14 7	50
20	SUN	2 SUNDAY IN LENT.	30.186	-30.117	38-15	N.W.	—	6	22	5 29	12	14 1	51
21	M	Sun's declination, 10° 28' s.	30.362	-30.233	42-32	W.	01	4	24	6 14	13	13 54	52
22	TU	Early Moth; hedges.	30.574	-30.423	46-22	N.E.	—	2	26	6 50	14	13 46	53
23	W	Small Brindle; oaks.	30.637	-30.572	46-23	N.E.	—	0	27	rises.	☺	13 37	54

METEOROLOGY OF THE WEEK.—At Chiswick, from observations during the last twenty-six years, the average highest and lowest temperatures of these days are 46.4° and 33.1° respectively. The greatest heat, 57°, occurred on the 17th in 1847; and the lowest cold, 16°, on the 19th in 1845. During the period 104 days were fine, and on 78 rain fell.

BRITISH WILD FLOWERS.

POPPYWORDS.—PAPAVERACEÆ.

(Continued from page 335.)

GLAUCIUM.—HORNED POPPY.



GENERIC CHARACTER.—Calyx below the seed-vessel, of two oblong, concave, pointed, deciduous leaves. Petals four, much larger than the calyx, roundish, reversed-egg-shaped, wavy, crumpled, spreading, with short claws, deciduous; two opposite ones rather the smallest. Stamens numerous, with capillary, short filaments. Anthers roundish, terminal, of two lobes. Germen cylindrical, or somewhat compressed, longer than the stamens. Style none. Stigma large, abrupt, permanent, of two or three cloven, compressed, downy lobes. Pod linear, very long, of two or three linear, concave

valves, and as many cells. Seeds numerous, convex at the outer side, pitted in regular lines, without a crest, disposed irregularly in two rows in each cell, being sunk in the hollows of a spongy or membranous partition, connected with the linear marginal receptacles, which are placed between the edges of the valves, and bear the seeds on short stalks. Annual or biennial herbs, mostly milky-green, with yellow fetid juice. Leaves more or less pinnatifid, and subdivided; the upper ones stalkless. Flowers solitary, stalked, lateral or terminal, yellow, scarlet, or violet, very handsome.

GLAUCIUM LUTEUM: Yellow Horned Poppy; Sea Celandine; Sea Poppy.

Description.—It is a biennial. The whole plant very milky-green. Root spindle, or carrot-shaped. Stem round, smooth, about two feet high, strong, and much branched. Root-leaves stalked, divided into many sections from the margin to near the mid-rib, wavy, variously lobed, and indented; the sections gradually larger towards the upper end of the leaf; hairy on both sides; living through the winter. Stem-leaves embracing the stalk with their heart-shaped base; deeply indented, hairy above, smooth beneath. Branches in opposite pairs. Flower-stalks thick, rather hairy, mostly one, but sometimes two-flowered. Calyx large, oval, hairy, falling off as the flower opens. Petals large, egg-shaped, golden-yellow, with brownish blotch at the base. Seed-vessel about ten inches long, variously bent, rough, with small wart-like projections, but not hairy, terminated by a brownish, arrow-headed stigma. Stamens sixty or more. The flowers droop down until the day preceding their opening, they then become erect. The petals fall off the second day after they have opened. Seeds blackish, curiously celled.

Places where found.—On the sands near the sea-shore.

Time of flowering.—June to August.

History.—Its name *Glaucium*, alludes to its strikingly glaucous or milky-green colour; *luteum* was applied to it on account of its yellow flowers, but *flavum*, or bright golden-yellow, would be more appropriate. Its large and numerous flowers, although of short duration individually, succeed each other so profusely, as to be very ornamental. The whole plant abounds with a yellow, fetid, and poisonous juice. It is said to occasion madness, and probably is the *Glaucium* of Dioscorides. It succeeds if sown upon rock-work, and there is very effective. The named of *Horned Poppy* refers to the shape of the seed-pod. (Martyn. Smith. Sowerby. Gerard.)

WHATEVER may be said for or against the doctrine which we have endeavoured to propound in the leading article of our number for December 16 (page 196), respecting the origin of buds, so far as it is exemplified by our experiments on the Willow; or in whatsoever degree we may estimate the other ideas, hypotheses, or speculations, to which the mysterious origin of the purple Laburnum has given rise, both here and on the continent, that doctrine which admits the possibility, or, rather, the probability, of the soft or cellular matter, formed by two allied plants, being capable of intermixing together, provided the parts are brought into close

contact, and so kept during the formation of the soft wood, is by far the most important, in a practical view of this curious subject.

To this point, therefore, we shall draw the attention of the reader to-day, after first bringing before him, in one view, some of the principal bearings of the question, so far as they relate to this part of the subject. Some varieties of the *Pelargonium* are known to gardeners as notorious for making a kind of warty growth on the stem. We ourselves have seen this form of growth so far approach to the condition of the natural growth, that rudimentary leaves appeared in clusters on the upper

side of the wen, as it may be called; but we have never observed, neither have we heard from others, that they ever knew an instance in which a shoot-like growth issued from the wart or wen on a *Pelargonium*. Therefore, without altogether asserting the impossibility of such origin to a shoot of this plant, we may conclude that its appearance is of extremely rare occurrence. Here, then, is the first departure from normal growth, where the new growth is, or seems to be, incapable of extension. By artificial means, we all know that a vast number of plants can be forced to form a warty growth—the callosity, first formed on the bottom of a cutting before roots are to be seen is of the nature we mean; and such growths, in many instances, are capable of forming buds, which buds expand into plants that are even more true to their origin than if they had been raised from seeds.

The simplest means by which this may be proved, and the most excitable plant for the purpose of doing so, is the *Fuchsia*, for at this season, and for the next two months, it may be increased by the footstalks of the leaf. In a few days after the application of heat the bottom of the leaf-stalk makes a callosity, or warty growth; and in a few more days, a bud issues from the new matter, which grows as fast and freely as a seedling. Compare this rapidity, from the most slender footstalk of a leaf, in the *Fuchsia*, with the case of the Willows mentioned at page 197, which, at the end of seven year's growth, were utterly incapable of forming a single bud, even from a large surface of bark and wood; and yet we account the Willow to be fully, if not more, excitable in growth than the *Fuchsia*. We instance them, however—that is, the footstalk of a leaf of a *Fuchsia* and the Willow stems—as the extreme points of the question. The comparison must, therefore, lead to this conclusion—that we are totally in the dark with respect to the cause, or force, or principle, with which the origin of buds is involved; and that, in the absence of direct experiment, no one can foretell whether this or that part of a plant or leaf is, or is not, capable of originating an adventitious bud from an accumulation of growth forced on the plant, as it were, by any process familiar to the gardener. If that be so, there can be no solid foundation on which to raise an objection against any experiments which we may propose with the view of testing the possibility of an amalgamation of the growths of two allied plants, in the first instance, and then to see if such united growth is, of itself, capable of forming a bud; and if it is, whether that bud is likely to combine in itself some of the properties peculiar to the two plants whose united growth and force caused this bud to spring into life. If it could be easily proved that this is really within the compass of possibilities, the principle, though hitherto it was hidden from our eyes, is of the utmost value in the improvement of races, either of fruits, vegetables, or flowers.

The easiest and most speedy method that we can suggest for arriving at this knowledge is the following, and we appeal urgently to our amateur friends to put the experiment to the test this very spring:—Practical gar-

deners have so many calls on their time at this season, and, indeed, at all times, that no one can expect them to be able to give the requisite attention to any experiment which does not directly bear on the requirements of the day. We all know that the *Fuchsia* will root from the footstalk of the leaf, and that the new bud comes from the upper part of the warty substance which is first formed, or from the very end of the stalk, which is now much swollen with the force of growth. The *Orange Tree*, and a hundred other trees and plants, will make increase after the same manner; indeed, there are a large number of plants, whose very leaves, if cut across the middle, and the top part inserted like a cutting, will thus form roots, buds, and shoots, with less or more difficulty, according to the kind, and the completeness of the arrangements in the propagating department. There is one tribe of plants, however, which, for the ease and rapidity with which this experiment may be decided by them, we recommend to begin with, and they are the different species and varieties of *Gloxinia*. Less than a square inch from the blade of the leaf of many of the kinds will make roots, buds, and plants, if a portion of the rib or vein is taken with it, and the whole is placed under favourable conditions. A leaf of this kind, taken with the whole stalk to it, and the stalk inserted as a cutting, will soon form a regular, solid bulb from the warty matter sent down by the leaf and stalk, and this bulb will produce a bud and shoot in five or six weeks.

Now, does it not seem very feasible that, if two such leaves were first united together by inarching their footstalks, and then planting them as one cutting, that instead of two little bulbs they would expend their juices in the formation of only one bulb; or even if a disposition to form two bulbs showed itself, could it not be subdued, and so the union of the two leaves be forced to form only one bulb?

The next question is, would one such bulb form two buds, or two sets of buds, each of which sustaining the character of one of the leaves only? and if so, would it be possible, in the next trial, so to manage the issue of two combined leaves, as that it would produce but one set of buds only? We see no difficulty in arriving at conclusive answers to these questions. We shall, therefore, show how the experiment is to be handled, so as to insure, as much as possible, the exact degree we ourselves would aim at.

First, make choice of any two kinds of *Gloxinia*; we say kinds, because there is now no limit between species and varieties in the genus, and kind includes both species and varieties; let the two be of different colours, force them into strong growth, full in the sun—the back of a cucumber bed would be the best place, on account of the air being admitted over them. When the leaves are fully ripe, or say, when the flower-buds rise prominently, take one leaf from each plant, cutting the footstalk as low as is safe to do so; then cut off a slice from the *front part* of each of the stalks, about an inch-and-a-half long, forming the bottom of each into a sharp wedge; after that, splice the two together, and bind

them closely with a soft woollen thread, leaving only about a quarter-of-an inch bare at the bottom. After drying for an hour or so they will be ready for insertion as one cutting; the two leaves ought to look face to face, and be so placed in the cutting-pot that one side of the spliced parts may rest against the side of the pot for safety, as that side is less likely to damp than the other which is covered in sand. The sand should be higher in that side of the pot where this doubled cutting is planted, and the water to be applied in the lowest side, so that no water may touch the spliced part. At the end of twelve or fourteen days after this, the ball of sand, or very sandy peat, being damp throughout, will bear to be gently turned out of the pot and the progress of the bulb or bulbs below ascertained; then, if two separate bulbs appear, the edges of them next each other should be dried a little, so as to cause them to unite and form, ultimately, but one bulb. We believe, that the bud on a single bulb thus produced is always formed on that side of it which is immediately beneath the front part of the leaf; hence, our reason for slicing off that part from each of the two leaves to be united. As soon as the union bulb is full grown, and before the decay of the two leaves, it should be stimulated by increased heat and moisture to cause it to form a bud, or buds, and to grow, ere the force of the vegetable action is over for the season.

Upon the same plan and principle, other experiments with different kinds of plants might be instituted, such as cuttings of two kinds of *Dahlia*s, *Paeonia*s, or, indeed, of such other plants as form tuberous or fleshy roots, from which the annual growth proceeds. Should it turn out, as we may reasonably suppose, that two united leaves will, each of them, form an independent bulb for itself, might we not endeavour to get the two to unite into one mass, and confine the future growth to one side only, and still be able to procure some share of the quality of the other side into this growth? If that is practicable, how dexterously the beautiful shades and variations of the *Gesnera zebrina* might be inoculated into any of the allied kinds.

Whatever may be the event, the question, as it stands at present, is full of promise and very inviting.

Let us now turn our attention to trees and shrubs, fruit bearers, or merely ornamental by their gaudy flowers, and bear in mind the experiment on the Willows (page 197), which goes to prove that a-year-old shoot, if once divested of its buds, is for ever afterwards incapable of reproducing adventitious buds, and consequently, that two such shoots cannot assist in the formation of buds, from cellular matter formed by one or both of them, even were the two growths made to run into each other. But take two-year-old shoots, or, for greater certainty, say three-year-old wood, and inarch them together, keeping the buds on each as nearly opposite one another as can be; then, when the union is firmly made, let the buds on each shoot be destroyed, and all other buds also that may start from the same parts; now the two shoots must be cut back to within one or two joints of the inarched part, and no more upward

growth allowed to them, in order, if possible, to force a bud from the new matter between the two united shoots.
D. B.

FORSYTH MSS.

(Continued from page 359.)

MR. WEDGEWOOD having suggested the foundation of the London Horticultural Society, as mentioned in our last number, we find that he proceeded seadulously to strengthen the list of those who would aid it in its infancy; and that among those were the Marquis of Lansdowne, Mr. Angerstein, and others of similar influence, and similarly attached to gardening. On the 8th of March, 1802, he wrote as follows to Mr. Forsyth:—

“On the other side, you have a kind of preface to the rules of our intended Society, which I have drawn up at my leisure. I must trouble you to fix some hour that I can spend with you to talk this matter over, and put things in a train that we may put our intentions in execution. Since I saw you, I have written to Dr. Smith,* explaining our intention, and hoping to have his concurrence in the scheme. He has given me a very obliging answer, and desired me to use his name as I thought proper. I hope we shall thus steer clear of all jealousies and animosities with other societies.”

“HORTICULTURAL SOCIETY.

“In almost all the counties of Great Britain are now established societies for the improvement of agriculture, which have been attended with more or less success, by the introduction of new breeds of cattle, or new implements of husbandry, &c. Some of these societies have considered orchards as a branch of agriculture which deserved peculiar attention, and have given premiums accordingly:—For example, the Society for the Encouragement of Arts, &c., in the Adelphi, and the Bath Agricultural Society. This last society has given a premium for raising new sorts of apples from the pippin. These appear to be the only instances where any branch of gardening has been encouraged by the agricultural societies, and they only so far as they are considered in an agricultural point of view. It is now proposed to form a society for the sole purpose of encouraging horticulture in its different branches, to form a repository for all the knowledge which can be collected on this subject, and to give a stimulus to the exertions of individuals for its farther improvement. It is well known to all persons who have made inquiries on this subject, that there are various facts relative to gardening confined to small districts, which would be of general service if communicated. These facts will be collected by the society, and the knowledge of them generally dispersed over the country. The following rules and regulations have been drawn up as the basis of the society, by which it will be clearly seen that there is no intention of interfering with any other society whatsoever, but, on the contrary, a wish to concur in the general improvement of the country.”

Mr. Wedgewood was timid as to the reception the proposed association would meet with from other societies, but this nervousness was misplaced. The Linnaean did not object to the formation of a society having for its object the culture, and not the scientific arrangement, of some of its own subjects; and the Society of Arts had never made gardening one of its pet protegés. All, therefore, was to proceed over a smooth road and beneath a cloudless sky. It was not, however, until the appropriate spring time of 1804, that a sufficient number of supporters had been obtained, and the plan was sufficiently matured for even a preliminary meeting. On the 7th of March, 1804, this meeting was held at

* Sir J. E. Smith, President of the Linnaean Society.

the house of Mr. Hatchard, in Piccadilly. This meeting was attended by the Right Hon. Charles Greville, the Right Hon. Sir Joseph Banks, Richard Anthony Salisbury, Esq., W. T. Aiton, Esq., Mr. Forsyth, and Mr. J. Dickson. Mr. Wedgewood presided, and the necessary resolutions were adopted. It was also agreed that each of these original members should have the privilege of recommending three persons as additional members. Who these were, was to be determined at another meeting on the 14th of the same month; and who were Mr. Wedgewood's nominees appears from this letter to Mr. Forsyth, dated on the 9th.

"I shall be much obliged to you to name for me at the meeting on Wednesday next, Dr. Smith and James Vere, Esq. I expect a letter will be left for me at Mr. Hatchard's, from Mr. Hawkins, to say whether he chooses to become a member of our society or not. Be so good as to open the letter, and if he chooses to become a member, add his name to the list. If he does not choose, and you have a fourth name, you may add it to my list."

Then came the always difficult question of nominating the officers, with all its usual attendants of jealousies, and conflicting struggles. The Secretaryship was especially a subject for these petty influences; and one corner of the veil that was dropped over the mysteries is raised by the following letter. It is dated April 3rd, 1804:—

"Since we last met I have been employed in the business of the Society, and have been talking about the election of a Secretary, and am sorry to say that I find so strong a prejudice against Dr. Anderson that I should advise his friends not to propose him. As a member of the Society, he is thought a very proper one, but not as an officer. You will excuse my giving you this hint, but I think it more friendly to you than to let you name the Doctor as a candidate, and then have these objections brought forward, and the Doctor be rejected. You will now be best able to judge how far you think it advisable to nominate Dr. Anderson as a candidate.

"There will, on the 11th, be laid before the Society the outline of the rules for the Society, who (the members) amount to sixty-one in number. I was at Angerstein's on Friday last. There are no early grapes coming forward, for Stewart has been employed all winter rather as bailiff to the estate than as gardener. He is a determined enemy to grafting Vines. I wish to see a fair experiment made on that subject, and would myself enter into it if I had leisure to attend personally to it. He says you will have plenty of wood but no fruit. I say you would have improved fruit in plenty, as well as plenty of wood, but experiment must determine the fact."

Finally the Association was incorporated on the 17th of April, 1809, as THE HORTICULTURAL SOCIETY OF LONDON.

The Charter states the Society to be for the improvement of horticulture in all its branches, ornamental as well as useful, though the president, Mr. Knight, declares their attention to be chiefly confined to the latter. This exclusion of all writings that relate to landscape gardening from their Transactions has been blamed by some persons, I think inconsiderately, for nothing new can be stated upon its general principles, and particular details can be of comparatively little service, for the genius of every place, and the taste of every proprietor differs.

The original corporation of the Society consisted of George, Earl of Dartmouth; Edward, Earl Powis; Brownlow, Bishop of Winchester; John, Lord Selsey; Charles Greville, Esq.; Sir Joseph Banks, Bart.; W. T. Aiton; John Elliot; T. A. Knight; C. Miller; R. A. Salisbury; J. Trevelyan, Esqrs., and J. Dickson; T. Hoy; and W. Smith, Gardeners.

The Society has power to purchase lands, &c., and is liable to be sued, and able to sue; to have a common seal; an indefinite number of Fellows, the power of naming which was to be in any five of the above-named original members before the first of May, 1809, but afterwards to be in the power of any seven or more Fellows. The Society is to have a council of fifteen Fellows, a President, Treasurer, and Secretary. The first President to be the Earl of Dartmouth; Charles Greville, first Treasurer; R. A. Salisbury, first Secretary. New ones to be elected annually. The president is every year to appoint four Vice-Presidents from among the members; three of the council to go out annually, and three other Fellows elected to their places. Vacancies in the council, &c., are to be filled up within two months. When bye-laws are made or altered, which must be at a general meeting, a majority at least of two-thirds of the Fellows present is required, and those present must amount to seven.

COVENT GARDEN.

THERE is a great deal of sameness pervading the market at this season of the year. Instead of the continual succession of variety which is always presented during the summer and autumn months, we see now, week after week, as it were the same old faces. We cannot expect there will be any great alteration in this respect for some time to come, and it is very evident that even the dealers themselves feel the difficulty of keeping up the interest which is requisite, for positions that are usually occupied with some choice home production, we find now set apart to Chestnuts, Oranges, and other such foreign introductions. The greatest display is produced by the Cut Flowers and Oranges, they make, in fact, a perfect glare, but we see nothing of late Apples and Pears, unless it be a few *Golden Knobs*; but there are a dozen or more other sorts we could mention which could be there just as easily. In PEARS there are a few shrivelled *Ne plus Meuris* and *Buerré de Rance*, with here and there a parcel of *Easter Buerré*; but that is all.

There has been a plentiful supply of all sorts of VEGETABLES during the week, and with little or no variation in the prices. *Savoys* are still making from 6d. to 1s. per dozen. *Brocoli*, good-headed, 2s. to 2s. 6d. per dozen; but the small in bundles are from 2s. 6d. to 3s. per dozen bundles. *Greens*, 1s. to 2s. per dozen bunches. *Brussels Sprouts*, 1s. to 2s. per half-sieve. *Carrots*, 2s. 6d. to 3s. 6d. per dozen bunches. *Turnips*, 1s. to 1s. 6d. per dozen bunches. *Onions*, 2s. 6d. to 3s. per bushel. *Leeks*, 2d. per bunch. *Spinach*, 1s. to 2s. per sieve. *Lettuce*, 6d. to 1s. 6d. per score. Forced *Asparagus*, 5s. to 7s. 6d. per bundle. *Sea-Kale*, 1s. 6d. to 2s. 6d. per basket. *Rhubarb*, 9d. to 1s. 6d. per bundle. Good *Potatoes* still maintain high prices, particularly *Regents*, which realise from £6 to £7 10s. per ton.

Plants in pots and Cut Flowers are very plentiful and fine; the former consist of *Heaths*, *Camellias*, *Hyacinths*, *Polyanthus*, *Narcissus*, and *Tulips*. CUT FLOWERS consist chiefly of *Camellias*, *Chinese Primroses*, *Geraniums*, *Cinerarias*, *Violets*, *Snowdrops*, &c.

H.

GOSSIP.

THE long-disputed question, whether a Shanghae hen ever lays *three eggs in a day*, seems quite determined by the following letters from a lady with whom we have corresponded:—

“So much has of late been said touching the merits and demerits of the Cochin-China fowls, as compared with others, that it is only right that anything remarkable respecting them should be stated. I have a pullet which was hatched in April, and on the 8th of December laid her first egg. Since then she has five times laid three eggs in one day, and this occurring twice in one week. On Monday last she laid three eggs; on the three following days one egg daily; and on Friday, again, three well-formed, good-sized eggs; and this morning (January 22nd) one.

“The pullet is a well-shaped bird, buff colour, and bred at New Brighton, from a pair sent as a present from America.”

Wishing for fuller particulars, and for a detail of circumstances, we ventured to send a list of queries, which elicited the following satisfactory reply:—

“In answer to your inquiries respecting my Shanghae pullet, the strongest proof I can give you, and I think an unquestionable one, of the eggs being laid by *her* is, that she was the only fowl laying amongst my small stock, which then was only four, and is now six. The first day she began laying she gave three eggs; I am sorry I have not taken note of the number of eggs she has given since beginning, but I was from home until the 3rd of this month, and unable, from ill-health, to pay particular attention to them, but the servant who has attended to her, says she is sure, during the first five weeks, she laid upwards of fifty eggs.

“I have only had four pullets laying, and can tell for a certainty the egg each lays. This one lays eggs very deep coloured, and nearly round in form. The eggs have never all three been found in the nest at once, such frequent visits are paid during the day that the egg is brought in as soon as laid; but having now only three pullets laying (my fourth has been sitting the last fortnight), and getting five eggs in one day, and two of those so different to the other three, there can be no mistake, I am sure, about them. The bird is, of course, a great favourite, and an object of much interest, and is, I should say, in good health, lively, and takes her food; but whenever she is going to give the three eggs becomes very heavy, and unable to move about much: when this is the case we frequently lift her into the nest. She has not been laying the last week, but has commenced again this morning (January 28th).

“I am quite willing that notice should be taken of this in *THE COTTAGE GARDENER*, but should prefer (if the purpose will answer as well without it) that my name should not appear in print.”

We are very glad to observe that the Caledonian Horticultural Society have offered a silver medal to be awarded to the journeyman or apprentice gardener, who

shall produce the most approved *original plan for laying out a flower-garden and shrubbery* (together not exceeding an acre), with a list of the plants best suited for the design, and a brief detail of the management best calculated to produce ornamental effect throughout the year. We equally rejoice that the same Society offers another silver medal to the journeyman or apprentice gardener who shall produce *an original plan for the best arrangement of a kitchen-garden* (not exceeding an acre, and which may include the space allotted to Melons and Cucumbers); and a third silver medal to the similar party who shall produce the best plan of similar extent (one acre), being *a combination of the flower and kitchen-garden*. In both there are to be full details of the plants to be employed, their management, &c. The plans, &c., must be sent to the Secretary, Professor Balfour, before the 31st of next July. Any one desirous of competing, had better apply to the Secretary for full particulars of the conditions and requirements. We repeat, that we rejoice to see such prizes offered by one of our national Horticultural Societies, and we hope that other similar societies will follow the example. By so doing they will more fully carry out the objects specified in their charters than by all their annual exhibitions. We should be sorry to see these Exhibitions diminish, but we certainly do wish to see some more of the funds directed to the object emphatically named in their charters—“the useful.” If they offered such prizes as those now offered by the Caledonian Horticultural Society, they would soon have original materials for publications worthy of being published in their at present mis-named journals or transactions.

The right course is being pursued by Mr. M'Glashen, of Edinburgh, to effectually bring to notice his *Patent Tree-lifting Machine*. Next month, in the gardens of the Horticultural Society and elsewhere, he is to exhibit practically its efficiency..

The *Gardener's Journal* states that the Brazilian Pampas Grass (*Gynerium argenteum*) is in such demand, that although half-a-guinea is the price of a small plant, and one guinea that of a large one, the supply is not equal to the amount of orders received.

So gross has been the mismanagement of *The Royal Forests*, that in the year 1851-52, the total returns from them amounted to no more than £61,437. To obtain this, the mismanagement cost £38,926, so that little more than £22,500 was received as profit to the revenue. The only crop which the Forests excel in producing, is a crop of poachers. We once heard a Magistrate say, that from the purlieus of the New Forest it would be no difficult matter to collect 6000 well-armed good shots from among the labouring classes.

The following is extracted from the first number of a very excellent and cheap periodical, entitled *The Scottish Florist and Horticultural Journal*. The essay, which we give nearly entire, is by Mr. James Cuthill, of Camberwell, and is entitled

“MARKET GARDENS ROUND LONDON.

“The readers of this periodical must understand that the London market gardeners are a most exclusive set of people,

and determined to a man that all their secrets shall remain with them, and in their hands alone. If a question is put to them, their mouths are at once sealed. They will not give information; but they will endeavour, if possible, to deceive you, and even when anything new is discovered, this principle of secrecy is carried out with their next neighbour. All admit that London furnishes the finest flowers, fruits, and vegetables in the world, and the reason is, London contains the world's wealth, being the great resort of the aristocracy, and the very centre of commerce. This being the case, market gardeners have always got the highest prices for their goods. This stimulates them to greater exertions to get heavier crops, and those of the finest quality. Manure, the very "gold dust" of high cultivation, with them is cheap and plentiful; without this the London market gardeners would not be one bit better than those of any other neighbourhood; in addition to this, London being such a large city, the suburbs even, on account of the large number of horses, cows, pigs, &c., which are kept in them, yield great quantities of rich manures. Therefore market gardeners so situated get their manure at the cheapest rate, and they sell their produce at the very dearest. The large competition which exists among growers makes them very quick, and most excellent men of business. They have good selected seed, proper times of sowing and planting, with an enormous quantity of seed-beds always ready. I have seen myself nine acres of seed-beds of cabbages upon one man's ground, and every one of them planted out by November.

"I have lived in what are called the Fulham Fields, which are now market grounds; this district lies west of London on the north bank of the Thames, with a very gentle slope to the river, running westward some eight miles, and bounded on the north side by the Brentford or great western road, containing many thousand acres. This is the spot where the finest things are grown in general; but there is a tract of ground, less or more on the Surrey or south side of the Thames, reaching from Camberwell all the way to Richmond, a distance of some ten miles, which is little, if any, inferior. The Surrey market gardeners also produce first-rate things, and were they as close upon London, with no tolls to pay in taking their produce to market, they would match the Fulham growers. Then, again, there is a district between London Bridge and Greenwich called the 'Jamaica Level,' this is also on the south side of the Thames, nearly all of which is in Kent. This low-lying piece of ground is very rich of itself, having been washed by the Thames, which has left a rich deposit of soil many feet deep,—so deep that the very best Liquorice has been grown there. This part produces very fine strawberries, rhubarb, horse-radish, and the finest sea-kale of all. These, then, are the principal districts near and around London. Then further into Kent, "the garden of fruits of England," great quantities and great varieties are grown there for the London markets; for instance, very early peas and asparagus round Gravesend, &c., with enormous crops of fruits of all sorts, spread here and there all over the county. Then we cross the Thames into Essex; there again they produce peas, beans, cabbages, onions, &c., even as far down as Colchester, whence famous early asparagus, &c., is sent to town. In leaving Essex, passing along the northern skirts of the city, touching part of Hertford, the land in general is not so congenial, being mostly clay; here very little, except at Enfield, is produced for the London markets. Then westward of Brentford, in the districts of Isleworth, Hounslow, Teddington, &c., the very finest productions are raised, such as (Beach's) strawberries, by which he surprised the world in the Crystal Palace, many of them weighing three ounces. I have seen his grounds there when in full bearing, and such heaps of British Queens upon one plant, and such big plants I had never seen before. Then Bedfordshire supplies cucumbers by the waggon-load. Turnip-tops come as far off as from Buckingham and Berkshire; besides the enormous quantities of hampers of all sorts of vegetables sent by families, &c. London swallows up everything, with its three millions, and its tens of thousands going in and coming out; still no town in the world is better supplied with fruits, vegetables, and flowers.

"Some years back, I took Mr. Smith, of Deanston, over part of the Fulham gardens; he was perfectly astonished.

He looked for big hedges, big ditches, and weeds, but none were to be seen. The grand secret after all is in a nutshell. Continual dunging, trenching, or bastard-trenching (that is, the dung and part of the top mould put in, and one spit afterwards), hoeing whether there are weeds or not, with the best of seed, and attention paid to the proper times of sowing and planting. There is no drawing up of the mould to keep the cabbages, as some suppose, from being blown down. Drawing up the mould is never practised by the best gardeners.

"It was at one time considered by market gardeners to be beneath their notice to grow flowers; but now they all do so,—such as Stocks, Pinks, Picotees, Cloves, Ranunculuses, Anemonies, Heartsease, Daisies, Ariculas, Geraniums, Mignonette, Polyanthuses, Violets, Roses, and every saleable blossom of every sort. I have seen myself nine carts and waggon loads of vegetables from one man's ground, all sold in Covent Garden by nine o'clock in the morning. The first loads are put down in the market, and they go back for more in the course of the night,—this is at the height of the season. Some idea may be formed of the quantity, when I state that a London waggon contains 150 dozen of Spring cabbages. The market in Covent Garden, some ten years ago, commenced at two o'clock in the morning, but now between three and four; this difference is caused from the enormously increased supply; the buyers know now that they cannot be disappointed, as they often were ten years ago. No longer can such prices be realised as 25s. per lb. for grapes, nor £2 for a pine of two lb., nor 15s. for a melon, nor 10s. for a cucumber, nor 4s. for a pound of potatoes; these days are gone by;—railroads have done wonders. The old market gardeners are astounded at present prices; but they do not suffer so much, since they get everything cheap for their use.

"Growers of seeds suffer most, as the Continental cultivators sell their rubbish so cheap; this, in the course of time, will entirely destroy our fine breed of vegetables which we have taken many years to improve. Just think of foreign onion seed at 9d. per lb., that for which we used to get 3s. and 4s. Foreign growers grow all sorts of cucumbers together, and all sorts of cabbages and onions, so that our vegetables will soon be as mixed as an Irish stew. Just look at the tons of horse-radish that come over every winter from the Continent; you may just as well try to scrape a broom-stick. Their asparagus is all white, and as hard as their horse-radish. The worst of it is that the English people don't know what it is; it ought to be sold, as the chicory is now, with a ticket on it, the stuff would very soon find its level—let any one try to eat a Dutch melon, or a French cucumber—compare them with our growth. All this cannot now be helped; but the seed ought to be put a stop to directly—deal with no house a second time where the seed turns out all sorts of mixed rubbish, you may be sure that it did not grow in Kent, Essex, or Surrey. The other day I asked a large grower in the Fulham fields if he still saved cucumber seed? He said, no; the seed merchant would no longer give a fair price, as they could get foreign so cheap. He used to grow twelve acres. Again, some years ago, he used to save two tons of cauliflower seed—this he was obliged to give up. Now, one thing is certain, market gardeners grow seed for their own consumption; but what will become of the growers elsewhere, who are obliged to depend upon the London merchants? I know every one of them, and they have no desire to buy the foreign; but they say that the country people apply to those who advertise far below the real market prices. Growers ought never to buy of these people, it is 'cheap and nasty,' and sure to end in disappointment.

"We must not overlook the herb grounds round London, which are very interesting. The district where herbs are cultivated, is Mitcham, in Surrey, about nine miles south-west of London, where hundreds of acres of all sorts are grown. As the stranger approaches that locality in the summer time, with the wind in the south-west, the combination of odours can easily be discovered in the air, which is 'redolent with sweetness;' there are hundreds of acres of liquorice, of lavender, and peppermint, for distillation, &c. The cultivation of mint is very easy and simple; it is ploughed-in every winter. This does not destroy the mint-roots, on the contrary, it improves them, as

it kills all weeds, and the mint grows up in rows abundantly strong the next year. Liquorice is planted in deep, well manured ground, eighteen inches in the row, and nine inches plant from plant. When the stems and leaves are in full growth, they look like a plantation of sapling ash trees, growing to the height of four and five feet; these are cut down every year, and the horizontal root or rhizomes, travel along the surface: these having joints and eyes, are the propagating root. Every one must be forked up every winter. They are sold for sweetening beer, &c.; but they are not near so sweet as the real root, which descends many feet into the ground: the crop is taken up once in four or five years, according to the state of the land. The price for the best roots is about £60 per ton; an acre will produce four and five tons. The price of the ground at Mitcham is three to four pounds per acre. Lavender is a most important crop; this occupies some two or three hundred acres; for this the ground is trench-ploughed. The land being all very light, this is easily done. It is planted in November and March. The old plants are split down by the hand, the more they are split the finer the plants, for on this depends the number of roots. Generally about three to six are dibbled in every hole—they are planted about five inches deep, leaving only three inches of the tops above ground. They are planted two feet each way; and during the second year, an acre will fetch £20 for distilling purposes. The heads are used for fine oil, the flower-stems for rougher oils. The proper time to cut, is when the lower blooms are just beginning to turn brown; and, after cutting, the sooner it is distilled the better, for if left too long, it loses much of its fragrance; but Mitcham grows all other sorts of herbs; and even the London birds are not forgotten—groundsel, chickweed, and all other things. I saw, in fact, men, women, and children, who had nothing else to talk about but herbs! herbs! herbs!"

SHANKING OF GRAPES.

AFTER the numerous disquisitions concerning this serious evil during the last twenty years, it is strange that complaints are still abundant. Scarcely has a week passed during the period referred to but one portion or other of the gardening press has contained remarks concerning it. From this it might be inferred very fairly that the subject is a most difficult one, and that in some soils or situations the evil *must* prove invincible. I am, however, quite of a different opinion, and would rather suggest that the subject has been overlaid; that an affair simple in itself has been too much mystified. It is in gardening difficulties, as with those in many other professions; the mind, in endeavouring to collect facts throwing light on the subject, gathers many that are of little import, and the whole matter becomes confused, whilst, perhaps, the greatest point of all is made to assume a mere secondary position.

As to the consequences of what is termed shanking, I may just inform those who have not yet made so unlucky an acquaintance, that it consists of a great portion of the bunch shrivelling up, generally about the period of colouring and acquiring flavour. They of course become flavourless and worthless, and assume a peculiarly crabbed taste. It is almost needless to add, that the disappointment is great to a lady or gentleman who, possessing but one house, loses one of the most important items of the dessert table. To market gardeners it must be almost a ruinous affair, but I imagine they are less liable to it than the rest of the community. High rentals, and an enormous outlay in labour, &c., produces a kind of caution, and a business-like way of doing things, which in general stands the test. These men cannot afford to indulge in whims; they do not theorise much, but generally seize hold of one or two of the chief facts connected with culture, and at once proceed on them; thus their views of things are generally simple and bold, and devoid of extraneous considerations. It

must here be observed, that our first-rate men of practice have at times taken different views concerning shanking; such views, however, may in the main be comprised in two points, viz., bad atmospheric management, and imperfect root action; beyond these, I am not aware that any point worthy of consideration has been urged.

To prepare the mind of the reader for a *full and free* examination of this serious matter, let us for a moment take a glance at out-door vines and pot vines, as compared with those of the hothouse or vinery. Having lived several years in a northern county, where the culture of out-door vines is seldom attempted, it might be imagined that the writer of these remarks could scarcely take a fair survey of the matter. In my younger days, however, having spent many years in the vicinity of the metropolis, I became perfectly aware of the position of out-door vines; for, be it understood, their culture on the open wall is much in the same position it was forty years since; nothing is really new, as far as I am aware, beyond the late Mr. Clement Hoare's ingenious mode of culture—more ingenious than sound. As to pot vines, it is notorious that shanking has not been attributed to them, as in the case of vines planted in what are termed borders. Vines against the open wall, too, out-doors—many are the complaints about their non-ripening, but few indeed about shanking; as to imperfect ripening, through deficiencies of climate, we beg our younger readers to beware of mixing this case up with shanking—it is altogether different. Having thus opened the matter as to its most salient points, I will endeavour to show forth some material circumstances, which at all times affect the well-being of vines, and in the present case are, in my opinion, the mainspring of the evil in question. In doing this I will take hold of the two chief points under consideration—viz., the influence of badly constituted soils on the root action, and the influence of corrupt or badly graduated atmospheres on the leaf action. Who has not seen vines in a damp house produce roots from their stems, and why? Because they want to change their character, and assume the habits of orchids? No; let us rather infer that there is some discrepancy between the functions of the roots and the branches—in other words, nature is baffled.

I will almost engage to defy any practical gardener to affirm that he can compel vines to evolve stem-roots in-doors, if the vines have a *sound, good, and well-managed* border, and an internal atmosphere the reverse of stagnant. Now, I think it will be found that vines which are so very apt to produce stem-roots in the house are bad ripeners, and are very apt to shank; if so, I have made out a case in favour of the opinion, that capricious, or rather imperfect root action, is at least one of the pre-disposing causes.

And how could it be otherwise? Admitting that the vines were rooted in a border too deep, or too stagnant in its own character, or the soil too adhesive, and that about the period of the commencement of the last swelling an unusually wet period set in, what would any practical man imagine as the consequences?—What state would he expect to find the finer fibres of the vine roots in, supposing that they could be exposed to the eye in all their ramifications? Nine out of ten men of experience would, I am persuaded, at once answer thus: "I should expect to find precisely the same effects as happens to any tender plant in a pot, which, after being injudiciously planted in too tenacious a soil, and badly drained, had been much over-watered, most of the tender points and spongioles of the roots discoloured, decayed, or decaying, and consequently, as some of our writers now say, 'the supplies cut off' until a new set of fibres can be produced." This, in the case of the vine, is a matter which, under a return of the most favourable

circumstances, *must* be a three weeks' affair, but this is, indeed, making the best of it. Well then, this granted for the sake of argument, into what position would a crop of grapes be thrown at the period of their changing colour? It would, doubtless, be thus: the supplies or alimentary matter requisite for carrying on the ripening process must be drawn from whatever secreted stores existed in the vessels of the vines, as long as such resources could be obtained, and the moment the supplies ran short something must give way, and what, but a portion of the fruit? We know that in such cases the foliage does not decay, it simply becomes lean, and active growth in part ceases—the vital action is reduced.

Thus, shanking cases assume varying appearances, consequent on the extent of the injury; some Grapes will simply lose the mere point of the bunch, in others a whole shoulder will go, and sometimes even the whole bunch. The extreme points, however, generally shank first, and no wonder; for, the berries having the power of taking up the accretive matter as it reaches them, those situated near the shoulder, after helping themselves, doubtless suffer little to pass on to the extremities; and besides, the sap vessels appear of greater calibre near the stalk than at the extremities.

I know not whether this course of reasoning may prove satisfactory, but it has long been my opinion, that the matter of shanking, although so puzzling to many, is traceable to a very simple affair. And, indeed, what more is it, than an attempt by nature at self-preservation: a part of the crop cut off, in preference to a permanent injury to the constitution of the tree; a phenomenon of annual recurrence in our fruit gardens with Apples, Plums, Cherries, &c.

It must not, however, be understood that I wish to insist on an imperfect root-action being the *sole cause*. Other causes may, doubtless, tend to produce it, or may act in concert with a bad border in bringing on this sad disaster. As two of the chief, I would beg to direct attention to imperfect ventilation and hurried ripening, as being, in a number of cases, productive of serious evils to the grape crop.

I well remember, about thirty years since, having grapes under my charge that were sadly given to this shanking, and as a youngster, I was puzzled with the case. I sought advice from a very sage-looking old gentleman who wore a blue apron, and who, in pursuance of the fashion of those days, marched about almost in military style, with a huge knife-handle sticking out just below his hip.

"Clap on plenty of heat," said he, "that's the only plan." Well, I got my fires to work in earnest, and in order to benefit by the old gentleman's advice in the fullest manner, I was very chary of giving air. This made quick work of it; I soon had the mortification of seeing the shanking much increased, and that already commenced making a speedy finish.

My advice now is, if your vines have not energy to carry out the ripening process well, give them *more time* to do it in. As for imperfect ventilation, our friends may depend upon it, the vine does not enjoy a stagnant atmosphere any more than a stagnant soil, especially during the ripening period. Our out-door grapes might teach us a lesson; they generally colour well enough without any coaxing or coddling, provided the autumn is fine enough and early frosts do not supervene; and yet in September and October they *must* very frequently be subject to a temperature of from 35° to 40°, with chilling blasts into the bargain.

I now venture to express a hope that some of our readers, who have had *much experience* in grape culture, both in-doors and out, will be induced to offer any opinions, *based on facts*, that may either tend to refute or confirm what I have here advanced. I can only add,

that I shall be happy to be corrected by any gentleman in possession of such useful *facts* and a good temper.

R. ERRINGTON.

VINERY—GREENHOUSES.

A FEW men possess the rare faculty of speaking and writing upon a subject with such a combination of simplicity and high-toned intellectualism, that the philosopher is delighted if not instructed, while a mere child is at no loss thoroughly to comprehend the statements and arguments. When a man gives his attention to a totally new pursuit, he may be said to be a child in his knowledge respecting it. When enquiries respecting the primary simplicities of gardening have forced themselves upon our attention, I often have wished that I could get hold of a small portion of the valuable faculty above referred to; feeling but too conscious that many statements that would meet the case of a certain class of enquirers, would be looked upon as dull and insipid by another class, as well, if not better, qualified to give information than the writer. We are naturally so selfish, that in judging of an article, or a volume, we are too apt to decide by our own standard of advancement, and thus give or withhold our meed of approbation in proportion as we find a favourite doubtful practice confirmed, new ideas propounded, or sources of extended improvement opened up. Now, these are all proper courses to pursue when we wish to keep a record of our *own* progress, either by taking notes on paper, or, better still, fixing them upon the tablets of memory and judgment; but they by no means furnish data by which to judge of the beneficial influence of the works referred to. To do this, unless in special exceptions, when works are written to meet the case of a certain advanced class of students, we must not look down upon the *simplicities*, but recollect that if some of us are vain enough to suppose that we are reaching manhood in intelligence, there are many of our best friends just what we were once, merely babes and striplings. I confess I never read some statements of my honoured coadjutors, which, with more or less success, I have endeavoured to practise for years, without thinking how beneficial they will be to a large class of readers, and how useful they would have been to *me* years ago, when enquiries upon such matters were pooh-poohed, laughed and sneered down.

If facts within our own circle of acquaintance and private correspondence furnish any test of judging, then I may fairly conclude that our little serial, though it has not missed the approbation of the greatest gardeners, has more particularly gained the full confidence of those who have become convinced of the high degree of pleasure which even a small garden can yield: and I earnestly trust that attention to all the wants of such will ever form an element in its pages, becoming thus an incentive to enlightened progress, and a protection from errors and their consequent disappointments.

Last week I promised to allude a little more to the combination of plant house and vinery, and, in the first place, to the using of such a house chiefly as a *preservatory* of plants intended for summer display. Since I last wrote, an article has appeared from Mr. Errington on the management of the Vine. Keeping in view that such rules, only varying the time, will be as applicable to a late house as a moderately early one, our inexperienced readers will find that it contains the *pith* of the matter. Whether such a vinery have fire applied to it *now*, or the Vines be allowed to break off themselves, it will, during winter, be a better preservatory for summer plants than the best cold pit; but fire must be used to keep out frost, in unison with slight coverings, while in the pit fires may be altogether dispensed with, involving thus more care, but less

cost. The great advantages of keeping such plants in a house, rather than in a pit, are comparative freedom from damp, and the ability to clean, pick, and attend to the plants in all weathers. Such plants would rarely require an artificial temperature above 40°, while I have already stated that no undue impulse would be given to the Vines, if the average night temperature did not exceed 45°. We do not mean here to enter into the question of exposing vines to the open air, or, if under glass, allowing them to get a good nip of frost. We are sure that our friends with only one house will find none of these things at all essential to success, though ideas on these matters have prevented many from making that use of their glass which they might have done. When a selection is to be made, such soft-wooded plants as Senecio, Anagallis, Petunias, and Pelargoniums, should have a place in the house, while Calceolarias and scarlet Geraniums may remain in the pit. Verbenas, if potted or in boxes, will be better in such a house, though I have never preserved them better than by pricking out young plants in autumn, in a prepared bed, in a cold pit, taking care that the plants were not more than nine inches from the glass, and scattering among them some dry earth and charred rubbish during the winter. Planting out in light sandy soil saved the plants from many vicissitudes they would have been exposed to in pots. Even in the vinery house they will keep better in small wooden boxes than in pots. When a great number are required, everything may be kept in cutting pots or boxes, and be thinned about the middle of March, the hardiest receiving shelter out-of-doors, or in a pit.

As example is often a better monitor than precept, I mention the following:—Not so long ago, I was invited to see a vinery thus filled with stubby, healthy, bedding plants. In a pit near it were Endive and Cauliflower, as salads, grapes, and flowers were deemed essentials. Some years previously, advice was asked under circumstances very different. The vinery was empty, with the exception of a little Endive on its floor. The first part of the winter had been mild, which had encouraged weak growth among a mass of bedding plants, potted, and placed in a cold pit. Many of the things had been obtained in the autumn, and were expensive. The pit was extra damp from being sunk beneath the ground level. After the middle of January, the weather had been changeable, cold, and frosty, requiring frequent, deep, and long continued covering. When I saw them, a fungus damp had crawled over almost every pot, and wherever it touched a stem of a plant it became quite rotten. The theory had been dunned into our friend's ears, that though he only wished grapes in the end of September, he must grow nothing but Vines in his vinery. He made resolutions for the future, but what was to be done for the present? Singular enough, the weather being dull, the tops of the plants were yet sound, though *gone* below. In a day or two more, all might have gone to the rubbish heap. In a twinkling, every plant was cut over above the damped part, and laid down in a warm damp place just sprinkled with water. Then two or three lights were cleared; a hot-bed, consisting of a couple of feet of warm dung, made in the pit, covered with six inches of rotten leaf-mould, and four inches of sandy soil, covered again with a half-inch of silver sand. In this the erstwhile plants were inserted, after having been made into cuttings, and when growing, were topped and struck again; and from what our friend called this *lucky hit* he had a fine supply of plants during the season. Since then he strikes his plants out-of-doors, and in his pits in autumn; keeps them there until his grapes are cut; then cleans his house, and brings his young plants in, and allows them to remain until the buds of his Vines are breaking, when they are thinned by removing the hardiest first. When

the pits are cleared of the plants, they are filled with vegetables, and when these are gone part of the space is wanted for plants from the vinery, and part for cucumbers, &c., and when these again are over, or a supply is obtainable from the hand-light ridge, a space will be wanted under glass for cuttings. The house, too, is made somewhat ornamental during summer, so that it would be a rare thing indeed to find, at any one period, a yard of glass for a couple of days unoccupied. I have lately shown how to keep plants in cold pits *alone*; it will now be perceived that there is less difficulty when they can have standing room in a vinery unforced for three or more months in winter; but in the latter case the expense of a fire to keep out frost, and to keep the air in motion in dull weather, will be necessary. The above fact of striking cuttings from the tops of plants after they had gone at the collar, is of importance in the case of valuable plants, decaying or sickly, as, if not too far gone, the kind may thus be perpetuated, when otherwise destruction is inevitable.

2nd. *Having Vines up the rafters, but making them a secondary consideration.*—In such a case, the Vines would only give the shade, which creepers or twiners would do. In such circumstances, every plant we have treated on for the Greenhouse would be suitable, provided the Vines are not allowed to shade too much. In such a case you will obtain fine-flavoured, well-coloured fruit, but in general the berries will not be so fine as if you could have managed with less air, when the Vines were in bloom and swelling freely. In a single house I would always prefer Vines, even in such circumstances, to creepers, as some of the finest of these could be trained round a trellis or a bush, while, independently of the pleasure of eating the grapes, there would be a great advantage to the pot plants in having *no* shade above them in winter after the Vines were pruned. In such a house, avoiding too much shade in summer being kept in view, different tribes of plants would require the identical treatment we have hitherto described, so far as growing, resting, training, potting, watering, and placing either in the open air or in a cold pit, are concerned. The very shade of the Vines will, therefore, be of importance to plants beginning to grow and making their buds. But this will better appear under a third division, where Plants and Vines are to receive an equal amount of attention, and where there are the means of a hotbed, if not also of a cold-pit.

R. FISH.

THE PELARGONIUM.

(Continued from page 365.)

PROPAGATION BY SEED.—Perhaps in all the events of a florist's life there is none so interesting as that of being the successful raiser of an improved flower. It is no wonder that there are so many new ones annually raised; for, independent of the profit, there is an exquisite enjoyment from the time of the seed being sown to the period of blooming the seedlings. Like all other pursuits of life where there is an uncertainty in the issue, the fruition is waited for with an anxious, pleasing anticipation.

In Pelargonium raising there is a greater uncertainty than in most other florists' flowers, for the foliage is no guide whatever in judging whether the bloom will be improved or not, and there are thousands of seedlings raised annually that, instead of improvement, are found to be worse than the parents. In this point I think the raisers are as much to blame as nature; they are not sufficiently careful in selecting the varieties to seed from. High-bred varieties are very difficult to seed at all, hence it is saved from such (probably inferior varieties) as produce it freely. This seed, as might

be expected, does not produce better flowers. The remedy is easy enough. If a first-rate *Pelargonium* does not produce seed, there is a cause why. If the flower is carefully examined, it will be found the anthers are barren, and consequently the stigma is unfertilised. In such a case pollen must be had from some other flower with properties as good as the barren variety. Apply this pollen to the stigma, and seed full of vitality will be the fruit of the application.

It is not good to save seed only from one variety unhybridised; save it from several of different colours, and the chances of success are in proportion multiplied. Care must be taken that the pollen is procured from well-formed flowers, and applied to the stigma of such as are well-formed also (this form I shall describe shortly). By such precautions, good seed, that will produce more or less improved varieties, will be obtained.

As soon as this carefully hybridised seed is ripe it should be gathered, or it will be blown away. Put it in a paper bag, and hang it up in a dry room till spring. About the middle of February bring under cover some loam, peat, and leaf mould to dry, and, as soon as they are so, mix them in equal proportions, adding some sand to give it a sandy character, and to allow the water to pass through the compost in every part. Place a seed-pan or two also to dry, and see that they are clean, and also have ready a quantity of broken potsherds for drainage. Place a good layer of this drainage over the bottom of the seed-pan, and upon it a layer of the rougher parts of the compost. Fill up the remaining space with the compost itself, and level it gently with a flat piece of wood, or the bottom of a common garden pot; give it then a good watering, thoroughly moistening the whole contents of the seed-pan. Let it stand by quietly till the surface is partially dry, and then sow the seed carefully in rows across the seed-pan, giving each seed about half-an-inch square. My reasons for thus sowing the seed are to prevent them from damping off by being too much crowded if sown irregularly, and to give each seedling a better position, and more space to expand its roots and seed leaves; for it must be remembered, that if only two or three seedlings fog off, these may be the very ones that would be superior to the old ones; therefore, sow thin, and, to make sure, sow in rows singly. When all are sown, cover them a quarter-of-an-inch with some of the compost that has been sifted, give a very slight watering, just to damp the covering, and place the pans in a house or frame heated to 55° or 60°.

The seed will quickly vegetate, and as soon as the seed leaves are fully formed, and the real leaves are advanced a little, pot them off singly into what are called thumb-pots, and replace them in the gentle heat as near the glass as possible. Let them have a due portion of air every mild day, and as soon as the roots reach the sides of the pots, shift them into others two sizes larger. By this time the days will be longer and warmer, and the seedlings may then be placed in a cold frame, or pit, and have the glass light drawn off every fine day to cause the plants to grow stout and dwarf. After they have been so placed for a month, give them their final shift, till they bloom, into 5-inch pots. Several may flower that season, and every one that is well formed, with bright colours, should be carefully preserved, whilst inferior ones may either be thrown away, or planted in the borders till frost destroys them. Should the raiser be rewarded with a really first-rate flower, let him name it, and send it to some exhibition, and there it will obtain the approbation of the judges, and thus have a character and a value set upon it. Any that may not flower the first year, will certainly do so the second. These should be kept in their 5-inch pots, which will cause them to flower early the following year; but as soon as they show flower-buds,

they should have a gentle shift to bring out the blooms in full perfection and show.

Should any of these seedlings prove excellent and superior to any old varieties, or obtain prizes, the raiser should immediately propagate them by cuttings, for fear the original plants should perish, a circumstance not at all unlikely to happen if they are at all neglected.

The space allowed me is nearly filled, and I shall close this paper on raising seedlings by observing, that the zealous and enterprising florist must not despair if he fails in his first attempt at raising seedlings, but persevere and try again and again, till success crowns his efforts and rewards him for all his pains.

T. APPELBY.

(To be continued.)

PRESERVATIVE WALLS.

(Continued from page 344.)

LIST OF PLANTS SUITABLE TO PLANT AGAINST THEM.

BIGNONIA CAPREOLATA.—An ornamental climber, with reddish flowers; produced from side-shoots of the last year's wood.

BIGNONIA CRUCIGERA.—Another handsome climber, from South America, with yellowish flowers; requires more protection than the first-named species.

BUDDLEA GLOBOSA.—Though this plant is hardy enough to bear our ordinary winters, yet, it is so very ornamental, and produces its fine bunches of yellow globular flowers so freely, that I think it worthy of a place against a wall, especially if it is not heated or covered with glass.

BUDDLEA LINDLEYANA.—This species is more tender, but will live and flower much finer against a Preservative Wall than in a pot. The flowers are ornamental, and of a violet colour.

BUGAINVILLEA SPECTABILIS.—This plant has been thought difficult to flower. It has been hitherto grown in this country in warm greenhouses, and that is the reason why we have not flowered it. Planted against one of these walls, and allowed to run almost wildly, I am confident it would produce its splendid rose-coloured flowers.

BURCHELLIA CAPENSIS (Cape Burchellia).—Though this plant is usually considered so tender as to require the stove to grow it well, I am of opinion, that it would thrive well against a Preservative Wall, covered with glass, and heated; especially in the southern countries. I have grown it very well in a warm greenhouse, and flowered it there during the summer months, long after those grown in the stove had ceased to bloom. In fact, I believe it to be much more hardy than is generally supposed.

BUXUS BALEARICA (Minorca Box).—In the northern parts of Britain this fine evergreen box requires a slight protection. A cold wall will suit it admirably.

CALOTHAMNUS.—This genus is a native of Australia, and, like most of the plants from that country, only requires protection from frost. As they are all beautiful shrubs, with bunches of scarlet flowers, they are worthy plants for the Preservative Wall. The best are *C. gracilis*, *C. Knightii*, and *C. quadrifolia*.

CAMELLIA JAPONICA.—A large family of handsome shrubs and splendid flowers, now universally known. There is no class of shrubs so suitable for a structure such as I have described under the name of a "Preservative" and they are well worth a considerable degree of attention to grow them well. The border should be formed of peat and loam in equal parts, and put in without sifting; the drainage should be effectual, for the roots of Camellias are very impatient of stagnant water, or wet, sour soil. Therefore, let the drainage be

liberal, that is, plenty of it. The kinds best adapted for this purpose are the Old Double White, the *Vari-gata*, or Old Double Striped, the *Reticulata*, or Vein-leaved, and the *Waratah*. The last one blooms better in such a situation than in pots. There is no need, however, to be confined to these four varieties; any other would thrive equally well.

CAMELLIA SASANQUA (Tea-leaved C.).—Supposed to be a distinct species, the leaves are smaller than *C. japonica*, and also the blossoms. The latter are very beautiful, of a light rose-colour, and are produced very numerously.

CANTUA BICOLOR, C. DEPENDENS (OR *BUXIFOLIA*), AND *C. PYRIFORME*.—These three species, of a new genus, are very beautiful, half-hardy shrubs, which do not flower freely in pots. Against a Preservative Wall I have no doubt they would flower freely, and their flowers are so very beautiful that they are well worthy of a trial.

CITRUS (Orange-Tree).—Like the *Camellia*, this genus is exceedingly well adapted for a Preservative Wall. In Devonshire, it flowers and fruits against a common wall, without any heat, having only, in winter, the shelter of a mat hung down in front of it; but, as every county has not the mild climate of Devon, they require, more northerly, a more certain and effectual protection. A glass-covered wall, even without heat, will grow them very fairly, especially if the canvass covering, suggested by one of my correspondents, be used to cover the glass in severe weather. But the blossoms are so sweet, and so much used, as my friend Mr. Beaton observes, "for bridal bouquets," and the fruit is so handsome, that the complete Preservative, with glass and heated walls, is just the situation to grow both flowers and fruits to perfection; witness the fine specimens in the Preservative at Chatsworth.

The soil of the border should be richer than that I have recommended for the *Camellia*, and the loam should enter more largely into the compost. It should consist of two-thirds good strong loam, one-third peat, and about one-eighth of well-decomposed cowdung; this will suit them, and grow them satisfactorily. The species I would recommend, are the common orange (*Citrus aurantium*), the Shaddock (*C. decumana*), the Lemon (*C. limonum*), the Citron (*C. Medica*), and the Myrtle-leaved (*C. vulgaris myrtifolia*).

CLEMATIS.—I had passed over the plants of this genus, thinking they would be too rambling for this purpose; but as the very handsome flowering species, *C. azurea grandiflora* and *C. florida Sieboldii*, do not grow so rampant, and are not quite hardy north of Birmingham, a plant of each might be placed against this wall with the happiest effect.

CLETHRA ARBOREA (Tree-Clethra).—An old plant, with fine foliage, and numerously produced bell-shaped white flowers, deservedly worthy of a place to ornament this wall.

CLIANTHUS PUNICEUS (Crimson Clianthus).—A free-flowering, handsome, free-growing shrub, well adapted for the purpose, but requiring good protection.

T. APPLEBY.

(To be continued.)

A CHAPTER FOR COTTAGERS.

SINCE the repeated failures of the Potato crop has induced cottagers to turn their attention to other things, a few words on the culture of such crops as present the best substitute for that useful root may be of some service to that very numerous class of cultivators, whom we may, with perfect propriety, term "Cottage Gardeners," and shall commence our remarks with a notice

of one of the most useful roots we know, as a substitute, hoping that some kind friend will add the equally important instruction—the best and most economical way of preparing the article for food.

PARSNIP.—This hardy and much-neglected vegetable is not grown to one-half the extent that it deserves. It being a free-grower, not very choice about the kind of soil, and costing little in the shape of seed, it certainly has not found its way into such general use as might have been expected. One thing is, that, like the Potato, if not well grown, it fails to give satisfaction; and, though it will grow under almost any circumstances, yet it is only where well grown that it is really good. A rich alluvial soil, rather damp than otherwise, seems to suit it best. The cottager, therefore, whose garden presents such a soil, had better procure some of the seed and sow it as soon as he can manage to get his ground into anything like order, which, if it has lain stiff and untouched all winter, will work; but, if dug-up and sown at the same time, rows about fifteen inches apart, and the plants thinned out to about ten in the row, will, in most cases, be enough. It is almost needless to observe, that for this, and all other roots of a similar kind, the ground ought to be stirred pretty deep. One good property this root has over many others is, that it may remain in the ground where grown all winter, not only without detriment, but with advantage; only, when the spring sets in, the roots must be taken up and housed, otherwise they needlessly exhaust both themselves and the ground that produced them. Although as we have said the Parsnip likes a rich, deep soil, yet abundance of dung near the surface is hurtful, rather than otherwise; the tap-root, instead of being long, straight, and tapering, is often rendered forked and crooked. Every soil, however, does not produce good Parsnips, the best being grown in the south and west of England. In the north, except in some favoured localities, this root never attains that perfection which the Potato does under similar circumstances; and, as we have before observed, unless it be well grown, it is not good.

BEANS.—Although not capable of furnishing the table at the season when the Potato is most prized, yet, while it lasts, it is a favourite with many. It has also the advantage of being very hardy, will grow on almost any soil, and is tolerably prolific in regard to the number of dishes that may be gathered off a limited space of ground. In this latter property it certainly exceeds the Pea, besides which, it requires very little attention in the shape of culture. Stiff ground suits it best, and sowings of it may be made from the first of January to the end of June; of course the progress made the first two months will not be in proportion with the advance afterwards. The early *Long-pod* or *Hangdown* is better than the *Wonderful* for the first sowings, and the after crops may be the *White Windsor*, which is a better bearer than the *Green*. Rows two-feet-and-a-half apart, and the Beans about four inches apart in the row will not be too wide. Earth-stirring, &c., may be practised so long as it can be done without injury to the plants, by working amongst them; and, when the blooms are fully expanded at bottom, go over the rows and nip off the extreme tops: this prevents their running away in a long, useless stalk, and they become more fruitful in consequence, and the bottom pods come sooner into use by receiving that support which would have increased the stem upwards. This class of plants may be benefited by dung, although they are not such gross feeders as the Cabbage, and its kindred tribes, and on some ground that is already rich, additional manure would produce grossness instead of fruitfulness. Beans are less subject to disease than most other crops; but the black fly, or what in country phrase is called the Dolphin fly, often preys on their upper ex-

tremities; and last year, a sort of blight, or a something in the shape of atmospheric influence, destroyed whole fields of them, by rendering abortive the organs of fructification. This evil, however, is not of frequent occurrence, so that the cottager, who plants this crop on any ground not too light nor under trees, may count with more certainty of getting a crop than in most others that he commits to the ground, and that, too, with very little trouble.

CABBAGE.—This numerous family, next in importance to none for the long and faithful service it performs, is perhaps, next to the potato, the best and most useful vegetable grown for the poor man. Three or four sowings, and planting out at the proper time, will furnish a something for table every day in the year, either in the shape of full-grown well-hearted Cabbage, or, what is scarcely less useful, nice sprouts more or less turning into heart, or it may be perfectly green, in which case they are *Cabbage Greens*. Unlike the Bean, this vegetable can scarce have too rich a soil, it being a gross feeder, delights in the juices of the dunghill, and a soil of a medium character in regard to lightness or stiffness. The cottager who has only a few poles of ground, will find it more advantageous to buy a few plants of some reputed good grower than to grow them; but if he prefers the latter, seed sown about the 20th of July is early enough for the first batch, and the 12th of August for the main crop; another sowing may be made in March and one in May, and if the above be all planted out into rows about two feet apart, and the same distance plant from plant in the row, a supply will be kept up for the whole year. As the first autumn-sowing will, after being cut, produce three or four more heads, all likely to become good useful vegetables, provided the variety be good, for there are spurious sorts which have a tendency to run to seed the same season, and this propensity is much increased by sowing early in autumn, it is rather a critical point to hit on the exact day at which they may be sown. The time specified above is early enough for most places, except, perhaps, some bleak situations in the north, where they may be sown earlier. It would be useless mentioning the varieties, because each district has its own peculiar "best one;" but for very early use the *Fulham* is a good Cabbage for a general after crop, the *London Market* is also good, being larger than the former. There are several others of equal merit; other matters connected with them are both simple and easy. One thing we may observe, that they do not like to grow year after year on the same plot, nor on one lately tenanted by one of the same family, a change being beneficial to all. If the cottager has not yet planted his intended plot, he had better do so now without delay, selecting his plants from those that have been pricked out in autumn to some nursery bed, as they are shorter, and not so crooked in the stem, and sooner become good useful vegetables.

PEAS.—Although this cannot properly be called a substitute for the Potato, being a summer vegetable only, yet, as the failure of the former has directed attention to every thing likely to furnish our tables when the former is not there, a few may be grown; and if the space be limited, which it often is in well-kept gardens, rows six or eight feet apart will admit three or four rows of Brocoli, or similar crops, being planted between, which, though they would not make much progress while the Peas were there, would grow fast after their removal, and a good crop would be the result. The kinds of Peas proper to grow ought to be good bearing ones, not too tall, nor too short. A good early white one, as the *Emperor*, followed by the *Scimitar*, which is, after all, one of our best blue ones. Sticking carefully must be attended to in time; and the ground stirred and other attentions paid them will usually ensure success.

The first sowing may be in the middle or end of November; the second, about the new year; and successional ones, as required, up to July, after which we do not advise the cottager to try them; for though they may succeed well after that, they are a very uncertain crop then, and, in point of economy, fall short of many other things. Nevertheless, a few early Peas are always acceptable, that we recommend a few to be sown for use then; after which the ground may be more profitably employed. Where sticks cannot be had to support them, a dwarf kind must be grown, as *Bishop's Dwarf*, *Woodford Marrow*, *Bedman's*, and some others of more recent date; but they are less prolific than the taller kinds, and, consequently, are not so valuable when sticks can be had.

There are other useful substitutes for the Potato, to which we shall return at another time; but, as our space is fully occupied, it is only necessary to call on the cottager to look carefully over his ground, and see what can be done to bring it into good working trim at the shortest possible time. Directions given in former articles will materially assist him in that respect. He must also look over his stores, and see the condition his remaining *Potatoes* may be in. His *Onions* will also want looking to, and any very small, useless ones may be collected together, and at once planted in some favourable place; they will produce bulbs fit for use some time before the spring-sown ones come into use. A few good bulbs may also be put into the ground to produce seed, and, of course, while looking over these and other stores, all decayed or faulty ones must be removed.

J. ROBSON.

GARDEN LABELS.

EXPERIMENTS are the stepping-stones to progress, and progress is the pioneer of discovery. I hit upon a plan lately for labelling my border-flowers, which seems likely to prove a good one. The label is of wood, but, instead of being written upon, a number only is used, and this number is burnt into the wood. The following simple plan effects the object: Get two flat pieces of iron, one of them half-an-inch, and the other three-quarters-of-an-inch wide; let both be about seven inches long, an eighth-of-an-inch thick, and tapered to points at one end; leave the narrow piece of iron flat, but curve the broad end of the other into the form of a **C**; insert the pointed ends of each into a cork, to serve for handles; and with these tools, which a blacksmith will make for twopence, you may mark any number of labels you please, using, however, *letters* instead of *ciphers*—thus, 90 would be **XC**. It is a nice amusement of a winter's evening to sit by the fireside, with a table before you covered with labels, and by means of these irons (I use two), inserted in the fire, stamp the labels, one after the other as the irons become hot. Practice makes perfect, and a few trials will insure accuracy and dispatch. The advantages of the plan are, simplicity, cheapness, and durability, besides which you have the operation in your own hands, and can mark any odd label, or number of labels, as you want them. A lady, who is one of my family, says that the plan is a capital one; the truth is, that she excels me in marking the labels, both in speed and execution.

The following sketch may illustrate the subject better:



—S. P., *Rushmere*.

EASY MODE OF HEATING.

As you were kind enough to say that you would insert my description of my greenhouse if I would send you the particular dimensions, I have forwarded you a sketch of the whole apparatus, which I think you will understand better than I can tell you by words. You will see by the sketch that the apparatus for heating the water is formed of three pipes, going right up the back of the fire-place, but it gives much too strong a heat for my small greenhouse, and I think it would heat one three times as large. In the closet, which you will see goes under the stairs, I have put two good large boxes, filled with leaf-mould, into which I put, on the

20th of December last, some roots of rhubarb, dug out of the garden, and is known among us as the common red rhubarb; and yesterday (the 16th of January) I got from them seven sticks of rhubarb, the length of each stick being twenty-two inches, full an inch in diameter, and of a beautiful colour. Since I wrote to you before, I have fixed a box on one of the pipes, about twenty inches long and nine inches wide, filled with wet sand, into which I put three pots of cuttings, two of calceolarias and one of verbenas. They have been in about ten days, and they have grown I think full an inch-and-a-half in length, and look very healthy indeed. I covered the box with glass.

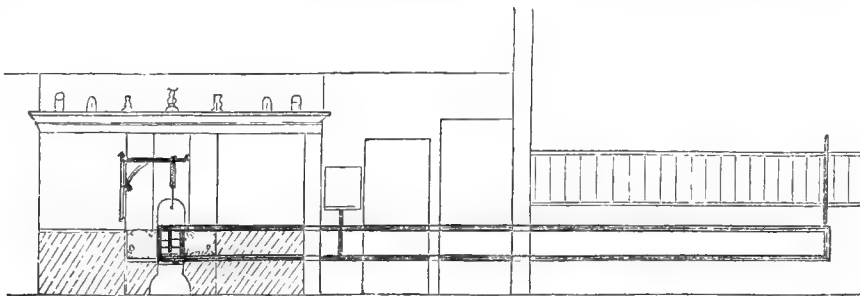

a The fire-place, with the three pipes instead of boiler.
 b Cistern kept with water in it, for the supply of the pipes, with which it communicates.
 c Closet under the staircase.
 d Staircase.
 e Greenhouse.

The greenhouse is twelve feet by eight feet, and three feet high on the walls, with a stage the whole length of the place. The pipes are shaded dark, and pass through a closet from the kitchen fire-place to the greenhouse. The return pipe comes along the front of the grate, and passes through between the bars at the bottom, to the back of the fire-place, and then, in an inclined plane, forms the back of the grate. The flow pipe comes over the top of the grate, at the back of the oven, and lies on what we call the hob at the end of the grate.—R. BRADBURY, *King's Bromley*.

THE MARKING OR FANCY COLOURING OF FOWLS.

As there appears to be a great want of uniformity in the appellations of the various markings of fancy fowls, I think it may be useful to describe all the different fancy colours that I am acquainted with, and as these markings show best on the feathers of the hens of the respective varieties, it is to them I shall confine myself. But I must beg my readers to bear in mind, that different individuals vary slightly, and that feathers from different parts of the body of the same bird also vary.

I shall commence with THE SPANGLE. This marking is becoming scarce. I am only aware of two varieties of fowls thus adorned; the true old Spangled-Poland, and the *Spangled-Bantam*; some approach to it may sometimes be seen among the common barn-door fowls. The ground colour is various—as black, brown, or golden, sometimes marked with black, but always tipped with a clear shining white spot, giving the wearer a beautiful appearance. This, then, is the true Spangle, and to these white spots sparkling out so bright and clear from the darker ground, in my opinion, is Dr. Johnson's definition of a Spangle quite applicable.

PHEASANTED.—Of this variety of marking, there are two sub-varieties, those with golden or silver-ground colour; but each having a black spot at the extremity of each feather. Being black where the true spangle is white, this marking receives its name from its great resemblance to the feathers of the neck of a cock Pheasant; not as some persons fancy from any cross with Pheasant blood. The Pheasant-marking is found in the Gold or Silver Pheasant Dutch Every-day-layers, the Pheasant Bantams, and the Hamburgs (*I mean those with the tuft*, or the Poles with combs), for since the name of Hamburgs is applied to the Dutch Every-day-layers, these fowls have no name left,

for they are certainly not *Spangled Poles*, as some call them, which their colouring, being either pheasant or laced, is quite sufficient to show, independently of their having a comb; nor do I think that the black spots can properly be called spangles.

LACED.—Of this marking, like the last, there are two varieties, the Golden and the Silver-laced; the feathers are clear of either colour, edged with a narrow black border, which gives their wearer a scaly or imbricated appearance, and received its name from some fancied resemblance which it bears to the meshes of net or lace; of this marking are the Gold and Silver-laced Bantams, some of the *Dutch Every-day-layers*, and occasionally the nameless fowls, or Tufted Hamburgs. This marking used to be called "Pheasanted," and is still frequently confused with it, for it is true many of the feathers of a cock Pheasant also show this imbricated marking, and some fowls blend the two.

PENCILLED.—In this variety the markings vary rather more in some individuals, and is principally confined to the Dutch Every-day-layers. There are also two sub-varieties, or the Golden or Silver-pencilled. The most general arrangement of the markings is that of regular bars of black on the ground-colour. Slight variations sometimes occur; thus under the black is often a shade of brown, and often the extreme bar of black will be bent round into an arch, or intersected in the middle, the markings always being regular and decided.

MOSS.—This marking is found among the Bolton Greys or Bays, which are only another variety of the Dutch Every-day-layers. The feathers, either golden or silver, are lined or grizzled with black, or some dark colour, and from a slight resemblance of this graining to the sprays or branches of moss it has received the name. When very indistinct, it is called *grey* or *grizzled*.

CUCKOO.—This marking is very frequent among common fowls. It consists of the feathers being shaded in alternate bands or bars of light and dark slate, one band being nearly black, and fading gradually into one almost white, and is thus continued to the end of the feather. The breast of the Cuckoo is thus marked; whence the name.

GROUSE.—Is of a rich reddish brown, lined or grizzled with a dark brown or black, and so called from its resemblance to the colour of the red grouse.

PARTRIDGE is of a duller brown, not so much grizzled as the Grouse, and the shaft of the feather being of a straw colour through part of its length, it is from its resemblance to the feather on the back of a Partridge that it received its name.

GINGER and NANKEEN are the old names for what are now called *buffs*.

It may not be out of place here to remark, that if feathers are pulled out it very often happens that those that come in their places will have white tips; and I have not unfrequently known a wing feather of a black or dark fowl to come white, if the one that previously occupied the place was lost by any unnatural means, more particularly if it was not full-grown at the time of its removal; and I have also noticed that, when a fowl has moulted unnaturally fast, the feathers are very much tipped with white, where previously not a white spot was to be seen.—B. P. BRENT, *Bessels Green, near Seven Oaks*.

[Mr. Brent has enclosed a variety of feathers for our inspection, as illustrating the marking of the different varieties. In the paper explanatory of his views on this subject, he commences with the *Spangled* birds, of which there are two specimens sent, black and golden. It would seem that he is as yet unwilling to abandon the old, and as so many think, confused system of nomenclature, and that under the name of Spangled Polands, he alludes to the Spangled Hamburgs. We had hoped, indeed, that Mr. Dixon's admirable work had set this question at rest for ever, for inevitable confusion follows its resuscitation. Nor can we assent to the Spangle being "a clear shining white spot" on a dark ground. So far from this being the case, Mr. Dixon insists for a clear white or yellow-ground colour in both varieties of Hamburgs, under which name he thus arranges the whole race of fowls that so perplexed the fancier of former days:—

HAMBURGHS.

PENCILLED FOWLS, WITH LIGHT HACKLE, <i>that is,</i>		SPANGLED FOWLS, WITH DARKER HACKLE, <i>that is,</i>	
Either pure White hackle,	} { Clear unmixed OchreyYellow.	Either White hackle, striped in the centre with Black,	} { Yellow hackle, striped in the centre with Black, Brown, or Green.
Chittapat. Bolton Greys. Pencilled Dutch. Silver Ham- burgh. Creole, or Coral.	Bolton Bays. Golden Ham- burgh.	Silver Spangled. " Pheasant. " Mooneys. " Moss.	Gold Spangled. " Pheasant. " Mooneys. Red Caps. Copper Moss.
N. B. — The Adult Cocks have in some fami- lies pure white hackle.			

The terms "Silver and Gold Pheasant" are admitted into this list, simply to point out what they are *not*: the sooner they are discarded the better.

Speaking of these *Hamburgs*, for it is evidently this bird to which Mr. Brent refers under another name, Mr. Bailey tells us, "there are two sorts, the golden and the silver; they differ in one respect only; the foundation colour of one is white, of the other yellow; their bodies spotted, or pencilled over with black."

The same ground colours, and the same black markings, are, moreover, always required in both Polands and Bantams, the only other Spangled fowls of a distant breed, properly so called.

The black and golden Spangled feathers, enclosed by Mr. Brent, do not, therefore, answer the description that judges would assign to the word *Spangle*.

Those marked *golden-pheasant* are a much nearer approach to the Spangle, which would, however, be required of a more oval form, and from the bright bay ground-colour of his *golden-laced*, they were taken, if we mistake not, from Polands, whose feathers, especially those on the breast, are often found more pointed at the extremity than is the case in other varieties.

But let us keep the *Spangle*, the *Pencilling*, and the *Lacing*, clear and distinct, and we are having engraved a good specimen of each, to enable our readers to steer clear of much confusion. This is the more necessary, since day by day the hybrid inhabitants of our farm-yards are exhibiting more or less strongly the varied and oftentimes strangely blended plumage of their different ancestors.

Pencilling we must, of course, regard as limited to the Hamburgs, for we have never seen it tolerably developed

in a barn-door fowl; and we do not despair of inducing Mr. Brent to assent to the classification now generally adopted, when we read his opinion that the Bolton Greys are only another variety of the Dutch Every-day Layers, which is one step in the right direction. His golden-pencilled feathers are good, but the silver should be more distinct; the lacing should be carried far more round the margin of the feathers, keeping an even width, than we find in any of those now before us; but those from *Scrutator's Gold* and *Silver-laced Polands* are perfect, especially the latter. As to *Pheasant* fowls, we think the less said the better; they are simply Golden-spangled Hamburgs.

The *Cuckoo* feather is very good. This marking, Mr. Brent justly observes, is usually found in the mongrel breeds, but when it is well-developed in the Dorking race, it is justly prized. Mr. Brent's specimen is remarkably good, the alternate bands being so delicately shaded one into another.

The specimens marked *Grouse*, reminds us how cautiously we should speak of those markings which are not strictly defined as the property and characteristic of some one distinct family. Many Game fowls are seen thus attired; and many more besides, of a parentage beyond the reach of inquiry. It will be sufficient, we think, for those who are interested in this research, if we eventually attain accuracy in the recognised varieties, without regarding illegitimate offshoots, whose shoots and transformations, as to colour, must defy the regularity of any systematic arrangement. For *Partridge*, what better than some of our dark Shanghaes of Mr. Punchard's stock?

The changes of colour that occur after moulting are attended with much uncertainty, especially with *black* poultry. Instances are on record, and quoted, if we remember rightly, by Mowbray, of hens of the black Spanish breed becoming perfectly white. Fowls that have had a prolonged moulting, no less than an unnaturally fast one, are subject to the appearance of white feathers where previously none existed.—W.]

THE COTTAGE GARDENER'S PONY.

(Continued from page 370.)

I HAVE often had to advise my friends on the propriety of keeping some sort of pony, one-horse chaise, phaeton, or other means of enjoying the country air. I have found that nearly as many people try the experiment and fail (after being at great expense and trouble), as succeed in deriving any rational source of enjoyment from their stable. Others, again, carry their fondness for horseflesh to as great an excess as the young gentleman in Aristophanes—

"By Neptune—the god of horses," passionately exclaimed the misguided youth. "Say not so," says the father bitterly, interrupting him; "no god inspired you with the love of horses!" A sentiment which most prudent fathers would agree in.

The injunction "not to multiply to yourselves horses," has been, I think, justly considered by commentators to carry with it something of the nature of a moral precept, as well as of a positive command; and much curious information has been brought to bear upon that point. Well, there is no doubt that the last European war convinced all good soldiers that, in the long run, it is the infantry which carry all before them; and that cavalry is an arm of strength but little to be depended on—a fact of which they might have fully informed themselves beforehand from a book which, I am afraid, soldiers do not read as often as they should.

It is my proposal to confine my remarks, as nearly as possible, to the most useful and least showy style of nag, which, without being an "uncommonly clean cob," a "well-seasoned hunter," or a high-stepper, or "remarkably fast in harness," will yet supply most of the reasonable requirements of country life—and those requirements are manifold. Except that we cannot get rid of a bad horse, by giving him "a month's wages, or a month's warning," and that the expense of frequently changing one's nag involves one of the most serious drawbacks against keeping one, with this exception, horses are not very unlike domestic servants—and the horse of which I have to write may be considered as a

sort of maid-of-all-work. It is best not to expect too much of them; and a little patience in bearing with faults we know, rather than flying to others that we know not of, is not unfrequently rewarded by the discovery of many latent virtues. The grand mistake lies in too often looking for impossibilities, and vainly expecting to find an ordinary and rather humble servant endowed with qualities not always met with in the most favoured of his kind.

The Baron Cuvier has told us that horses are used up in England ten times as fast as in any other state of Europe. It is the speed that kills them, generally speaking; the speed first of all, and next the enormous loads which we put behind them—enormous, I mean, considered in relation to the too usual rate of travelling; though probably, in regard to the class of horses of which I would be understood to treat, not such heavy loads after all, if the speed were slackened. Here then, at once, is opened a wide field for wandering in—I mean the matter of carriages and draught; and yet I can give but little advice about the choice of a horse, or his subsequent management, unless we have come to a clear understanding about what he has to do, and what weight to draw.

In general, country carriages are too heavy and too fine. They are mostly ordered in town, where they are intended a good deal for display, and are more of a luxury, and less a matter of a necessity, than in the country, and are kept by people of ample income almost exclusively; again, the distances in town are shorter, and the road more level and better kept. The distance between the hind wheels and the fore should be no more than just to enable you conveniently to ascend between them; yet for London work, where ladies are continually stepping in and out of the carriage, this distance between the wheels is in general much too great. The wheels themselves, also, are generally too small. The power of the wheel, considered as a lever, is directly as the semi-diameter, and inversely as the semi-diameter of the axle in the box.

In all cases of the lever, however, viewed as a mechanical contrivance, the necessity of economising power has its limits. Mere mechanical power is sometimes constructed in order to attain rapidity and safety of action, neatness, and convenience; and hence, not seldom, as in animal mechanics, so in mechanical contrivances to economize animal power, a form of lever is adapted which, at first view, seems to imply a considerable waste of strength. The London builder, then, was probably not far wrong when he designed that very light-looking, but uncommonly heavy-following, vehicle, which you have encumbered yourself with to begin with. It would answer the purpose of London calling, shopping, or park work, pretty well, I dare say; but ten miles of country work on end, upon indifferent roads, with a stiff hill or two to every mile of the way, and with a horse who had not yet learned to know his work, and a driver still less acquainted with the profound secret of adopting his speed to the road; a day's worrying with such a bargain as I have supposed you to have picked up, and a new horse, is just the thing to set all awry at the very first. It takes from six to twelvemonths to train an ordinary horse before he knows how to draw a pheaton without fatiguing himself, supposing even that he is not greatly overmatched with the work to begin with.

Now, my mare, "the maid-of-all-work" is to bring us all the manure into the hay-field; she shall fetch lime; coals for the house; frequently turn over (after the first ploughing, which requires two horses) some part of an acre of "field-garden" attached to the ground, wherein early potatoes, mangold-wurtzel, carrots, cabbages, &c., are produced in help of the winter provision; she shall fetch the market-stuff, new gravel for the walks, and what not. She must not take too much grooming; that will never do. I propose that she be turned out every night for the whole of the summer; and merely eat a couple of small feeds of corn during the day, in which case she will not require a great deal more looking after than a cow. And, if you are in pretty good health, gentle reader, and inclined to busy yourself and Caleb Balderstone, your man, in the garden, and the weather is favourable for long walks, why you must really give "the maid" a few weeks run out altogether, night and day, during the early part of summer. 'Tis the best method of prolonging the usefulness of the horse that I know. In the

stable it is, I think, indispensable that my horse, which has not got a groom on purpose to give the exact proportion of daily exercise, should have a large box, wherein to turn about, and shift from one posture to another. Take it altogether, I almost think that as much work may be got out of "all work" without interfering with the pretty frequent occurrence of pleasure excursions: almost as much work as will pay for the grooming; that is, supposing the lady or gentleman of the family usually drives. It is a serious matter, if the man-servant has anything else to do, that he should be perpetually taken off his work; put into livery, and set to drive about a gypseying, or taken to a country market town, perhaps to loiter about while his master and mistress is engaged. It is the ruin of a good hard-working servant; and a man who is expected to execute some remunerating labour for his wages.

By-the-by, I would never recommend you to load home your own hay from the field with your own horse. He is only occasionally put into the cart, and the hurry of the hay-field, the dangerous operation of loading, to say nothing of the casualties from a slippery barn-floor in unloading, all make it desirable that only practised horses should be employed in this process; and as any talk about making hay at Christmas is somewhat unseasonable, I think it is still better to turn my by-the-by into a good-bye, at least, for the present.—VIBGYOR.

(To be continued.)

POULTRY SHOWS

REIGATE.—This Show was on the 1st and 2nd instant but being confined to birds belonging to residents within a circle of fifteen miles round the Town Hall, was proportionately deficient in interest and utility. The object of such exhibitions ought to be comparison with the produce of distant localities. This affords stimulus to fresh exertion, and a good test of merit. To be the best at Reigate is very far below being the first where all England competes. The following is a list of the prize-winners. Classes in which no prize was awarded are omitted.

CLASS 1.—SPANISH.—For the best Cock and two Hens of any age.

First Prize—No. 3, C. Alloway, Dorking. Second—No. 1, J. Ivory, Dorking. Third—No. 2, J. Thompson, Wolvers Farm, Reigate.

CLASS 2.—SPANISH.—For the best Cock and two Pullets, chickens of 1852.

First Prize—No. 4, C. Alloway, Dorking. Second—No. 5, C. Alloway, Dorking. Third—No. 1, J. Nicholson, Reigate.

CLASS 3.—DORKING (Single-combed).—For the best Cock or two Hens of any age.

First Prize—No. 9, Earl Cottenham. Second—No. 8, J. Wicks, Cot-tager, Leigh. Third—No. 2, J. Ivory, Dorking.

CLASS 4.—DORKING (Single-combed).—For the best Cock and two Pullets, chickens of 1852.

First Prize—No. 2, S. Roots, Kingston. Second—No. 3, R. Clutton, Reigate. Third—No. 5, J. Lee, Horley.

CLASS 5.—DORKING (Double or Rose-combed).—For the best Cock and two Hens of any age.

Second Prize—No. 1, Rev. J. Herbert, Leigh.

CLASS 6.—DORKING (Double or Rose-combed).—For the best Cock and two Pullets, chickens of 1852.

First Prize—No. 5, J. Hitchens, Horley. Second—No. 2, R. Wol-laston, Reigate.

CLASS 7.—DORKING (White).—For the best Cock and two Hens of any age.

First Prize—No. 1, Emmeline Parrat, Effingham. Second—No. 2, J. Giles, Betchworth. Third—No. 4, J. Compton, Reigate.

CLASS 8.—DORKING (White).—For the best Cock and two Pullets, chickens of 1852.

Third Prize—No. 1, D. B. Hunt, Edenbridge.

CLASS 9.—COCHIN-CHINA (Cinnamon and Buff).—For the best Cock and two Hens of any age.

First Prize—No. 12, E. George, Coulsdon. Second—No. 2, T. H. Potts, Croydon. Third—No. 8, E. George, Coulsdon.

CLASS 10.—COCHIN-CHINA (Cinnamon and Buff).—For the best Cock and two Pullets, chickens of 1852.

First Prize—No. 15, W. W. Hayne, Sutton. Second—No. 10, E. George, Coulsdon. Third—No. 8, C. Rawson, Walton.

CLASS 11.—COCHIN-CHINA (Brown and Partridge Feathered).—For the best Cock and two Hens of any age.

First Prize—No. 1, T. H. Potts, Croydon. Second—No. 2, T. H. Potts, Croydon. Third—No. 6, T. Bridges, Croydon.

CLASS 12.—COCHIN-CHINA (Brown and Partridge Feathered).—For the best Cock and two Pullets, chickens of 1852.

First Prize—No. 4, T. Bridges, Croydon. Second—No. 3, J. Ormiston, Shabden.

CLASS 14.—COCHIN-CHINA (White).—For the best Cock and two Pullets, chickens of 1852.

First Prize—No. 2, E. N. Harper, Reigate.

CLASS 15.—GAME FOWL.—For the best Cock and two Hens of any age.

First Prize—No. 2, S. Akehurst, Copthorn. Second—No. 3, S. Akehurst, Copthorn. Third—No. 4, T. Berney, Croydon.

CLASS 16.—GAME FOWL.—For the best Cock and two Pullets of any age.

First Prize—No. 2, R. Clutton, Reigate. Second—No. 3, W. Purvis, Croydon. Third—No. 1, S. Akehurst, Copthorn.

CLASS 17.—GOLDEN-PENCILLED HAMBURGH.—For the best Cock and two Hens of any age.

Second Prize.—No. 1, M. A. Harper, Reigate.

CLASS 19.—GOLDEN-SPANGLED HAMBURGH.—For the best Cock and two Hens of any age.

First Prize—No. 1, C. Rawson, Walton.

CLASS 21.—SILVER-PENCILLED HAMBURGH.—For the best Cock and two Hens of any age.

First Prize—No. 2, M. A. Harper, Reigate. Second—No. 5, Rev. J. Herbert, Leigh. Third—No. 3, J. Lee, Horley.

CLASS 22.—SILVER-PENCILLED HAMBURGH.—For the best Cock and two Pullets, chickens of 1852.

First Prize—No. 3, A. Way, Betchworth. Second—No. 2, Emmeline Parrat, Effingham. Third—No. 1, J. Fisher, Reigate.

CLASS 23.—SILVER-SPANGLED HAMBURGH.—For the best Cock and two Hens of any age.

First Prize.—No. 2, C. Rawson, Walton.

CLASS 24.—SILVER-SPANGLED HAMBURGH.—For the best Cock and two Pullets, chickens of 1852.

Second Prize—No. 1, G. Larmer, Reigate.

CLASS 25.—POLANDS (Black with White Crests).—For the best Cock and two Hens of any age.

First Prize—No. 4, A. Buckland, cottager, Reigate. Second—No. 1, Hon. and Rev. A. Sugden, Newdigate. Third—No. 2, W. Truelove, Buckland.

CLASS 26.—POLANDS (Black with White Crests).—For the best Cock and two Pullets, chickens of 1852.

First Prize.—No. 1, G. Wythes, Reigate. Second—No. 2, H. Sayers, Reigate.

CLASS 35.—FOR ANY OTHER DISTINCT BREED.—For a Cock and two Hens of any age.

First Prize—No. 3, J. Giles, Betchworth. Second—No. 1, Hon. and Rev. A. Sugden, Newdigate. Third—No. 5, J. Arnold, Betchworth.

CLASS 36.—FOR ANY OTHER DISTINCT BREED.—For the best Cock and two Pullets, chickens of 1852.

Second Prize—No. 1, W. W. Hayne, Sutton.

CLASS 37.—FOR THE BEST CROSS BETWEEN ANY BREED.—For the best Cock and two Pullets, chickens of 1852.

First Prize—No. 3, J. Fisher, Reigate. Second—No. 2, C. C. Elgar, Reigate. (Cochin-Dorking.) Third—No. 1, Rev. J. N. Harrison, Reigate. (Dorking-Game-Cochin.)

CLASS 38.—BANTAMS.

First Prize.—No. 3, W. Relf, Reigate. (Silver-laced.) First Prize—No. 4, M. A. Harper, Reigate. (White Cochin.) First Prize—No. 5, G. G. Richardson, Reigate. (Black.) First Prize—No. 6, S. Roots, Kingston. (Gold-laced.) First Prize—No. 9, A. Smythe, Reigate. (Buffs.) Second—No. 2, Emmeline Parrat, Effingham. (Sebright.) Second—No. 7, J. Compton, Reigate. (White.)

CLASS 39.—GEESE.

First Prize—No. 4, J. Lee, Horley. (Toulouse.) Second—No. 2, C. Rawson, Walton.

CLASS 40.—DUCKS.

First Prize—No. 6, C. Alloway, Dorking. (Aylesbury.) First Prize—No. 10, R. Clutton, Reigate. (Labradors.) First Prize—No. 13, T. Page, Holmwood. (Aylesbury Muscovy.) First Prize—No. 15, W. W. Hayne, Sutton. (Rouen.) Second—No. 4, J. Giles, Betchworth. (Black.) Second—No. 16, Earl Cottenham. (Aylesbury.) Third—No. 8, A. Way, Betchworth. (Aylesbury.) Third—No. 11, R. Clutton, Reigate. (Wild.)

CLASS 41.—TURKEYS.

First Prize—No. 2, A. Way, Betchworth. Second—No. 1, J. Giles, Betchworth. (White.)

CLASS 42.—GUINEA FOWL.

First Prize—No. 2, J. Fisher, Reigate. Second—No. 3, G. Wythes, jun., Reigate.

ROYAL DUBLIN SOCIETY.—This Society's days of exhibition this year are the 29th, 30th, and 31st of March. Only one prize (£1) is offered for "a cock and two hens" of each of the usual varieties. The only peculiarities in the prize list, are one for "Three Capons," and one for "American" Turkeys. Specimens from England and Scotland are admissible.

BATH AND WEST OF ENGLAND AGRICULTURAL.—This long-established Society has a very rich prize list for poultry (£3, £2, £1) in each class, amounting to £85 10s. in the total. The Meeting is to be held at Plymouth, on the 8th, 9th, and 10th of June.

BIRMINGHAM CATTLE AND POULTRY SHOW.—The first meeting of the Council of the Birmingham Cattle and Poultry Show was held in this town on Thursday last, the members present being the Earl of Aylesford, Richard Spooner, Esq., M.P., C. M. Caldecott, Esq., Howard Luckcock, Esq., William Lucy, Esq., J. W. Whateley, Esq., Mr. John Bright, Mr. Charles Wedge, Mr. T. B. Wright, Mr. John Lowe, Mr. B. Dain, Mr. H. Lowe, Mr. John Shackel, Mr. Joseph Hardwick, and Mr. George Lowe. The principal business for which the meeting was called, was the consideration of the prize lists and regulations for the Exhibition in December next. In the lists for Fat Cattle, the prizes for Hereford, Short Horn, and Devon Steers, not exceeding three years and three months old, were fixed on the same scale as those for oxen and steers of any age, the first prize in each case being £10, and the second £5; a change which will still further carry out one of the distinct objects of the society—the encouragement of early maturity. The stock excluded from the classes for pure breeds, in consequence of the breeder being unknown, or from other causes, will in future be shown separately, in competition for silver medals only, and not in connection with cross-bred animals. The only other alteration, with regard to cattle, was the increase of the extra prize from £15 to £20; so that the best ox or steer of any age or breed will be a winner of £10 in his class, £20 as an extra prize, and a gold medal of the value of £20; and the same will be the case with the best cow or heifer. In the arrangement of the classes for Sheep, a change has been made, which we have no doubt will be considered judicious by the breeders of this stock. These classes now stand as follows:—*Leicester Sheep*; *Long-Woolled Sheep, not being Leicesters*; *South and other Down Sheep*; *Shropshire and other Black and Grey-faced, Short-Woolled Sheep*, and *Cross-bred Sheep*. The first prize in each class has also been raised from £8 to £10; the second remaining at £5, as heretofore. In the classification and prizes for Pigs, no change has been made; and the regulations of the Show remain precisely as they were last year. The increase in the amount of prizes for Cattle, Sheep, and Pigs, is £60; the total amount being £518, exclusive of gold and silver medals. The prizes for Domestic Poultry were also arranged, and will be at once issued. Several changes have been made, the most important of which it may be useful to notice. Instead of old and young birds competing together, as was the case last year, the classes will now be thus divided—"Birds exceeding one year old," "Chickens of 1853." The classes for Double-combed Dorkings are discontinued, as are also the second classes for Golden or Silver Poland. There are two classes for Turkeys—one for old birds, and the other for poults of 1853. The amount allotted for Poultry prizes has been increased this year by about £80; the total last year, exclusive of the extra classes, having been £123, while this year it is £201 16s. The only change in the regulations will be the substitution of the following paragraph with reference to the principles by which the Judges will be guided in making their awards, in the place of that which was in force in former years—"High condition, quality, beauty of plumage, purity of race, and uniformity in the markings, combs, and other characteristics, will, in all the classes for fowl, be taken into consideration by the Judges in a greater degree

than mere weight without these distinctions, if the more perfect specimens are at the same time of a fair average size." The subjoined resolution, with regard to the management of the Poultry Show, was unanimously adopted:—"That the following members of the Council, namely, Howard Luckcock, Esq., Mr. T. B. Wright, Mr. Benjamin Dain, Mr. Hubert Luckcock, Mr. W. B. Mapplebeck, Mr. John Lowe, and Mr. Joseph Harrison, be appointed a committee for the general management of the Poultry Show in December next; and that they be respectfully requested to ascertain if any and what alterations can be made in the arrangement of the pens, so as to facilitate the inspection of the specimens by the visitors; to decide upon the best mode of conducting the sales; to engage a poultry salesman, and other assistants; and to make such regulations, with regard to feeding, and the kinds of food which are to be used, as shall, in their opinion, be calculated to ensure the preservation in good health of the birds sent for exhibition." The new prize lists will, we apprehend, be considered by exhibitors generally as a great improvement, in many respects, on those of last year; and they will be received as a further evidence that the Council are prepared to employ every means at their disposal to ensure the continued success and utility of these popular meetings. The subject of holding exhibitions of store stock and agricultural implements was discussed by the Council, and a committee was appointed to consider the resolution to which we have before alluded, as having been passed by the Committee of Management for last year. This committee was requested to report in May next; and as it is desirable that the proposition should be maturely considered, and the opinions thereon of the leading agriculturists in the midland counties ascertained, the committee nominated is a numerous one. It comprises the following members of the Council:—The President (Earl Howe), the Vice-President (the Mayor of Birmingham), Lord Calthorpe, the Earl of Aylesford, Viscount Hill, Lord Hatherton, Lord Leigh, Sir George Richard Philips, Bart., Captain Dilke, R.N., Charles M. Caldecott, Esq., Baron Dickenson Webster, Esq., Darwin Galton, Esq., William Lucy, Esq., Howard Luckcock, Esq., Mr. T. B. Wright, Mr. Benjamin Dain, Mr. Hubert Luckcock, Mr. Henry Lowe, Mr. John Bright, Mr. Charles Wedge, Mr. John Lowe, Mr. John Shackel, Mr. J. Mathews. The Council unanimously agreed to present the sum of £25 to Mr. Morgan, the secretary, in addition to his salary, in consideration of his assiduous attention to the duties of his office. Mr. Morgan was also re-appointed.—*Midland Counties Herald*, February 3, 1853.

PRESERVING SPECIMENS OF ANIMALS.

(Continued from page 373.)

THE second method is what I generally use, and is a much quicker one, where the convenience of an oven can be had. In this case, the bird is to be prepared by opening as before, and stuffed with cotton or wool, but instead of the mixture, I pour in along with the stuffing as much common or Barbadoes tar as may be imbibed by that stuffing, but not more, as it would run out, and disfigure the plumage; the only use of this, to give a remaining scent, as little or none can enter the flesh. The proportion I allow is about ten drops to a bird of the size of a sparrow. Now, if the bird be placed in the posture by the means aforesaid, the rest is to be done by an oven of a proper degree of heat, by putting the bird therein. The only difficulty is to regulate this. The test is by putting some downy white feathers on a clean paper in the oven, and shut them up for five minutes, after which, if they are not discoloured, you may be sure that the birds will not be hurt. I generally feel the fleshy part of the thighs, to tell when they are enough done, and if this feels pretty hard, so that you can scarcely make an impression, I conclude it finished. I observe, too, the neck, if that is stiff, I suppose it enough. It will be necessary that, after the operation, the bird be put in a state of security from insects immediately on its growing cold, as they will be more liable to attack those done by the oven than the first way; indeed, I generally either put them in a very close drawer, or in the case I intend they shall remain, directly,

for on neglect of this I have lost many birds, notwithstanding any preparation. Should, therefore, any one intend to send a collection to his friend at a great distance he must attend to this. The way I should think likely would be this: As soon as any bird is done, have a large box or hooped-barrel, and lay a layer of very clean and dry sand, on this set each bird, sifting some more sand over it, to bury it therein, which, being carefully done, will not ruffle the feathers; put among the sand, here and there, whole pepper, or any other spice, and bits of camphor, this you may do till you have made the whole of the collection intended, and are desirous of forwarding them on ship-board; I should then pack them up in a lighter manner, by putting them in a box or barrel with soft cotton or wool, tight enough to prevent jostling against each other, with spice here and there, and when closed up for good, pasting thick paper on every crevice, with thick paste, adding to each pint of it twenty or thirty grains of corrosive sublimate (or white mercury), which will hinder insects eating the paste, and if the cotton or wool be put in an oven for half-an-hour before it is used for package, you may use it the more safely for that purpose. And I should think that even moss, dried in an oven, may pack them as well as any thing. The time I allow for a bird of the size of a sparrow, is an hour or two at furthest, the larger ones much longer, and some will require twice putting in the oven, remaining each time till cold. These methods need not be confined to birds alone, but the smaller kinds of quadrupeds, if curious, may be done by either of these ways. With a little more care, reptiles and fishes may be preserved likewise by one of these methods, though the general method is to put them into spirits of wine, brandy, or rum, which is a good way, where time or opportunity will not serve for the above.

Some sort of insects, as beetles, centipedes, tarantulas, scorpions, &c., may be put into rum or brandy, putting them one upon another without any care, except the not bruising them in the catching; but as many of these are adorned with beautiful colours, I have found it useful to add to the brandy as much loaf-sugar as it will take up, this prevents the spirits preying on that colour as much as may be.

As to butterflies. After catching them in a net contrived for that purpose, a squeeze on the body, without injuring the wings, while in the net, generally kills them, upon which the pin is to be run through the body, a little beyond the head; the head of the pin inclining forwards, and the point backwards, so that when the pin is set upright in a piece of board the back part of the fly will be higher the board than the fore parts, which, if raised one-sixth part of an inch, or one-fourth in large ones, will look the better; the wings are then to be spread, and kept in that manner by a slip of card, with a pin run through it, which is to bear gently on both wings, just so much as to keep them from displacing: thus they may remain for a week or more, when they will be stiff, and may be taken off and placed in a row on slips of deal, which may be made to slide one above another, in a box or case made on purpose, and if stuck very tight in, will transport anywhere thus without further trouble, except, on exportation, taking care to paste up the crevices everywhere with the sublimated paste before-mentioned, as well as sticking pieces of camphor in every slider, to guard against insects.

PHEASANTS.

(Continued from page 371.)

HAVING disposed of thus much, respecting coops, pheasantry, &c., we will now turn our attention to the birds themselves: premising a cock and two hens as a minimum of either variety in possession.

Each kind require the same treatment, as regard to rearing and food; otherwise than that, the Silver and common breeds are capable of roughing it more, and may be allowed game, or common hens, as foster-parents. In our case, however, nothing of the sort was practised; equal arrangements, care, and attention were given to all.

Sir John Sebright's *Golden spangled Bantams* were the variety kept to serve as matrons in our pheasant establishment, for which purpose no other sorts, so far as I am aware

of, are comparable. The *true* variety of these birds are of themselves very ornamental; they are also good layers, and, generally speaking, good sitters. Besides, a couple, or even three of them, when well fed, properly cooked, and placed on a dish at one end of the dining-table, with a pig's cheek *vis-a-vis*, flanked with cauliflower, asparagus, and appendages, such as gravy, melted butter, and bread-sauce, might serve a select gastronomic faculty to form a judgment, and pass a far weightier decision than that which would possibly emanate from a private individual like myself, upon a subject, at once so important, delicate, and interesting withal!

Sir J. Sebright's *Silver-spangled Bantams* are even handsomer than the above, but this is all; they do not answer in any respect so well for the purpose I am treating upon, and are even more difficult to rear than the Golden Pheasants. I thus mention them as a caution.

A cross between the pheasant and the fowl there never was, nor ever will be. Mr. Beaton has let us into the secret of cross-breeding as much as anybody. As a devourer of his articles, and as a title of compensation, I hereby state, that it would be about as reasonable to expect a cross between the Shrubland Geranium and the Hollyhock, as to hope for a like feature between the fowl and the pheasant. Varieties of fowl, even emanating from a cross with their own species, require to be narrowly watched, and kept up to the feather, or back to their maternal origin (otherwise sterility) they inevitably go—Sir John Sebright's Bantams not excepted. A new and *established* variety of Pheasant, by intercrossing with their species, I do not think can be arrived at; a few hybrids occasionally form a result, but are they not invariably a sterile generation? Enough has been attempted this way to allow the experiment to be fairly given up as hopeless.

Place a strip of turf, in the form of a half circle, at the corners of the pheasantry, for the purpose of securing, as a lean-to, some pointed spruce fir boughs; and form in the process two rather unobstructed entrances, on either side, with the ground for their base. The pheasants will at once adopt the concealment, and hollow for themselves a bare nest on the loose gravel, in preference to the exposed part of the pheasantry, retiring to lay their eggs there. Their Creator imprinted within them this modest fear and elegant instinct.

One might suppose the birds could be induced to *sit* also under these circumstances, but, no; repeated trials impel me to say—No. Possibly, the stimulus afforded them by an easy and bountiful supply of food is a reason why they almost invariably lay a larger number of eggs in confinement, than pheasants are commonly observed to do at large, but they appear to lose all interest in the sitting affair. When by chance a bird with us offered to sit, she performed the office in so irregular a manner that success never attended it. These stubborn facts led us to deprive them of their eggs on the day they were laid, excepting one or two to remain as nest eggs.

If we had not a Bantam, who desired to sit just at the time we wanted, or a sufficient number of eggs for the purpose, those by us were placed singly on bran, in a place of even temperature, with the day of the month on which they were laid written upon them, and they were turned once in forty-eight hours; in a case of necessity, and thus preserved, they would be safe to place under a hen at a period of six weeks from the time they were laid.

No one should think of placing a hen to sit otherwise than on the ground, for which the boxes already figured are purposely adapted; I can safely recommend them after ten years' trial. Procure a sound turf, three inches in thickness, of the same dimensions, and place it at the bottom of the sitting box; ram a slight hollow in imitation of a nest on the surface of the sod; a position to receive the eggs, inclining to that side of the box not opposite the entrance; thus placed, to see and not be seen, is what the hen so highly approves of; a thin layer of the newest and cleanest wheat-straw may be placed upon the turf.

Procure two nest eggs, to be temporarily placed there; and now, madam, to prove your power of endurance. Two or three days:—well! I find you have made up your mind, like a reasonable hen, firmly and determinedly bent on becoming a mother. Come, come, you need not be so

angry; but take care, do not peck a hole in one of those *eleven* eggs, for they come of a pedigree even superior to yourself, though it be of a like sounding oriferous nomenclature. However, an egg is an egg, all the world over with you, you are no respecter of eggs, whether they come of a golden pheasant, or a grey goose? More especially, when I tell you they were laid very *recently*, nearly all of them upon the *same day*, which you may observe by the writing, and by consequence will save both yourself and myself a vast deal of bother and anxiety; for they will probably all of them hatch on the *same day*, in three weeks' time. There, I place water for you, and barley shall not be wanting; I now feel myself perfectly justified with leaving you to perform all those little et ceteras with which I cannot possibly be thought to have any concern; those matters remain incumbent upon yourself as a hen; therefore, enjoy your own reflective, felicitous ruminations upon the subject; you may depend on me with regard to ulterior arrangements, such as chopped egg, and all that sort of thing. *Au revoir!*

A watchful eye must administer, for it sometimes happens that the hen will play truant from her nest too frequently, and too long at a time; this must be strictly guarded against; when you perceive her this way inclined, place something opposite the entrance of the box; remove the obstruction once in the course of the day, and then and there provide water and food, so that she may not have the slightest shadow of an excuse for neglecting her duty. At the expiration of *nineteen* days, something interesting may shortly be expected; the hen now hears the first cry of her little ones; her mother's heart warms towards them, and she will sit uncommonly close: do not disturb her, though it becomes advisable, at this critical state of affairs, in the first of the morning, and the last thing at night, to interfere somewhat by way of observation; for if, as it does too often happen when a sitting of eggs is placed under a hen, some are fresh and others stale, the fresh ones will inevitably hatch first; the consequence is, the hen becomes so excited and anxious to be off with these her first progeny, that she will unwittingly allow the remainder to become buried alive in their shells. To prevent a misfortune of this sort, remove those firstling instigators to all this mischief, and place them not too near the fire, in a piece of warm flannel, out of harm's way, and they will do very well there, for several hours even. To prevent her thus taking an early trip in the morning, before people are stirring, place an obstruction opposite her entrance at night.

Sufficient aliment remains to the infant creature within itself to allow a sustenance for the first twenty-four hours; though it is not advisable to push the extremity of these powers quite so far as that. I merely mention the circumstance, precautionary, as a guard against an over anxiety one often finds among good-natured people, to relieve the cravings of a supposed hunger the moment the birds are hatched; contrary to this, if the process go on well, and all is as it should be, they become considerably strengthened by allowing them to remain several hours quietly under the hen.

Returning from this digression, I will resume the worst feature, by supposing the remainder of the chicks come forth within the twenty-four hours; if not, and the eggs show no sign, place them near your ear, and give each a gentle shake, you will thus be made aware if they are addled. This is all the doctoring I resort to; I dislike, unless it becomes absolutely necessary, to assist the parturition of a chick from the shell. I always consider the merest novice of a hen more competent, agreeably with nature's dictation, to perform these functions. I also confess to be one of the worst doctors in the world. I do not like doctoring; and to tell the real truth, this science in our practice with poultry has always been at a nonplus. Remedy preferable to disease is our motto: therefore, as a leave go to this incubation process, I advise every sitting of eggs, pheasants, or what-not, to be fresh as fresh can be, and then, ten to one, but they all hatch freely, and at the same time.

A dry lawn or grass plot, is, if possible, the proper station to place the coop upon for the reception of the hen and her petite brood; they could not possibly be thought derogatory to the best situation that can be found.

The net protection figured with the coop serves admirably

for the young pheasants to feed under; also to protect them from birds of prey, or other disagreeables during the day. The front sliding board acting as a preservative against rats and other prowling vermin by night. It requires to be withdrawn very early in the morning, say by sunrise, and the coop shifted on to a fresh position. The birds are then fed, a repetition of which should take place every two hours at least during the day, consisting of variations from the following bill of fare.

Hard boiled eggs and bread crumbs mixed. Crushed groats, fresh from the mill, if to be had. Alum curd, and eggs, with the ants and flies accompanying them. Wheat after the first fortnight. Dispense with the egg, bread crumbs, and curd, after the first three weeks. With the groats at a month. Alternate barley with wheat, when the birds arrive at the age of six, or seven weeks. Any kind of fruit will always prove acceptable; and, above all things, a constant supply of *clean fresh water*. If they are not placed upon turf this necessary adjunct must be given in the shape of sods. Often scatter calcined, and pounded oyster shells, or pounded egg shells, for them to peck up at their pleasure; it keeps off the rickets, *i.e.*, it strengthens their bones.

This to some will appear a very civic mode of living; nevertheless, each and all of the good things mentioned above will be found as necessary to the artificial rearing, and proper *personnel* of the Pheasant tribe, as turtle soup, &c., is to the proper wellbeing of an alderman.

The curd is produced, simply by pouring half-a-pint of milk into a saucepan along with a piece of alum about the size of a nut; place it near or upon the fire till its casslin or muscle-forming properties (cheese) become apparent: strain off the whey, crumble the curd, and it is ready for use.

UPWARDS AND ONWARDS.

HINTS ON POULTRY BREEDING.

As it is desirable the highly descriptive and euphonious Saxon term, "gawky," should not descend in the persons of our Shanghai pets, I would venture a word *in season* to our zealous poultry-keepers, *not to breed from very young birds*; for assuredly, in the generality of instances, "like produces like;" and the older, and, consequently, more developed the parents are, in shortness of leg, breadth of frame, &c., so much the more will their chickens take after them in early maturity and precocity. If you wish to have chickens (high bred), loose and leggy, running about for six or eight months before they fall into shape, and deserving the characteristic term of the *Times* Editor, then breed from young parents before they have attained their size and character, which is frequently done with birds under seven months of age. The hen should, at least, be twelve months, and the cock two years if possible. It is also of importance that you select hens which produce the longest egg; for there is a marked difference in this respect, and our breed will fall into disrepute if this point is not more attended to. I maintain, one of the chief points of excellence in the Shanghai, is their property of laying throughout the cold winter months; in this respect somewhat singularly resembling our Chinese plants, which usually produce their flowers during our inclement winter season.—HENRY CURTIS, *Westbury-on-Trym, Bristol.*

TO CORRESPONDENTS.

. We request that no one will write to the departmental writers of THE COTTAGE GARDENER. It gives them unjustifiable trouble and expense. All communications should be addressed "To the Editor of the Cottage Gardener, 2, Amen Corner, Paternoster Row, London."

ERROR.—At p. 351, col. 2, line 34 from the bottom, for "longitudinal" read "transverse."

IMPRESSIONS OF LEAVES AND FLOWERS (W. H.).—Our correspondent will be obliged by information as to the best mode of taking these.

THOROUGH-BRED DORKINGS (*Charlotte Elizabeth*).—Apply to any of the chief prize-takers either at the late Birmingham or Metropolitan

Show. To give you the characteristics of these birds in the compass of a note is not in our power. You will have them given fully in the third number of "The Poultry Book." In the meantime, it will be a sufficient guide to say, that the *cock bird* should be single-combed, that the comb should be stout, well arched, and regularly toothed or jagged; wattles long and large, and bright crimson like the comb; breast wide and very prominently round; back broad and stout; neck hackles long, and forming quite a pellerine; tail ample, and well sickled; legs white or blue, short and stout; toes five in number. Weight not less than 10lbs. Carriage peculiarly bold and erect, and, when standing fully upright, about 22 inches high. The double, or rose-combed, differs only in that peculiarity. The *hen bird*, when fully erect, is about 19 inches high, and should not weigh less than 7lbs. Comb single and very low, in this or in the rose-combed variety; breast broad and prominent; compact in form; short in the legs, and these blue or white; feet five-toed, as in the cock, by an extra one behind. The colours are very various. If the skull of your *Spanish Pullet* is scalped, or laid bare, nothing, we fear, will induce the skin to reform over it. We should put on a piece of Diachylon plaister, and leave the rest to nature.

KEEPING EGGS (R. B.).—For using in puddings, we have known eggs laid in August good at Christmas. They had their shells greased all over with melted suet. Others have been kept as long in lime water. For sitting purposes, or breeding, there is no doubt that the fresher the eggs the better. A fortnight, or three weeks, is the extreme age of an egg that we should take for this purpose, where a choice is practicable. At the same time, if eggs are of a choice variety, we should not despair of their productiveness, though more than two months old; for we have been assured, by a practiced breeder of poultry, that six out of nine Bramah Pootra eggs produced chickens when full nine weeks old.

VINES FOR COLD GREENHOUSE (*Amicus*).—Your eleven Vines should be—Six Black Hamburgs; two Black Prince; two Royal Muscadine, and one Dutch Sweet Water. You could start them a little earlier in the spring by a hotbed within the house; but take care to start the roots a little earlier by a similar application. Can you not let the Vines into the house, by having the front lights made as depicted by us a few months ago? Carry this year's shoots into the house, and shorten them just within-side. Plant immediately Vines growing now in pots. We only know the *Raisin de Calabre* by name. Nothing more than this is given in the Horticultural Society's Catalogue.

SOFT AND IMPERFECT EGGS (I. B.).—Your Shanghai hen, which continues to lay so irregularly and so imperfectly, we have no doubt is suffering from inflammation, either of the ovary or of the egg-passage. Take her away from the cock for a few days, giving her at once one grain of calomel and one-twelfth of a grain of tartrate of antimony. Keep her in a moderately-warm, dry place, and repeat the dose at the end of two days if the imperfect laying continues.

SPANISH COCKEREL (W. H. S.).—We never knew a bird affected with white lumps, like maggots, below the tongue, therefore cannot advise you. "The Poultry-Book" will be published in half-crown parts.

LEUCOTHOE (*Subscriber*).—*Leucothoe* is one of the many second names given to *Andromeda*; you may see whole beds of them at Kew under that name, also the one you inquire about, *Andromeda nerifolia*. The *Pentstemon gentianoides*, the *Cobaea*, and the blue *Lobelia*, mentioned by Mr. Appleby, are on sale at his own nursery; and if he or any other nurseryman chooses, he can get for you any plant that is on sale, either in Europe or America. A plan is in contemplation whereby you may be aided.

CYCLAMENS (*Well-wisher, Isle of Man*).—The leaves perished on the way from London, and the growth is suspended—what is to be done? They must have their time; you cannot force them. Keep them in a state between dry and damp till they show growth, or enter their natural period of rest.

AMARYLLIS ATAMASCO (*Ibid*).—It is *Zephyranthes Atamasco*, and a pretty little thing it is, and as easy to grow as a Crocus, and very much in the same way when they are in pots, only that the *Atamasco* requires lighter earth, not peat. A five-inch pot will grow and flower seven full-sized bulbs of this Amaryllid, but they will do much better out in front of your greenhouse, in pots. *Atamasco* will not bear the least forcing. If the leaves do not come up soon, plunge the pot in the border outside at once.

AMARYLLIS FORMOSISSIMA, OR JACOBÆA LILY (*Sprekelia*).—It might be forced into flower from this time to the middle of May, exactly as they force Hyacinths; this blooms when the leaves have advanced from three to five inches, not before or after. This bulb should be planted out-of-doors by the middle of May, and left out till the frost comes, then to be taken up and dried for the winter; and, where there is only a greenhouse, April will be time enough to pot them; they will grow in any soil that will grow good potatoes. "Handsome climbers" will tease you to desperation, if you attempt to confine them to a space of two feet wall below the windows; pray be advised from your purpose, and put in *Tea-scented Roses*, or, indeed, anything but climbers; but if you must have your own way, take *Clematis azurea grandiflora*, and *Sieboldi*; *Calystegia pubescens*, *Mitrasia coccinea*, and *Lupageria rosea* at one end, with *Bomarea acutifolia* at the opposite end, and these two to make a fringe across above the others.

FLOWER GARDEN PLAN (E. B.).—Has there been a revolution in the Isle of Man lately, or have the ladies got the upper hand in the island, that so many of them find time to write such extraordinary long letters? If so, let us hope the rest of the "western islands" will not turn upside down also. This "plan" is drawn perfectly well for our purpose; the four corner figures in it, marked 10, are in better taste than any we know of near London. In the centre figure, the *Lobelia* in 2 and 6 ought to be in 2 and 5, being the opposite and match pair. The two kinds of *Calceolarias* in 5 and 7 should be in 5 and 2, or in 7 and 4, according

to the same rule. Such figures are not read like a book, straight on, but like one's face—two eyes, two eyebrows, two dimples, two blushes, one on each cheek, with one nose for a centre, and the forehead and chin, as end figures. To have one cheek *Pudibundus*, and the other, *Azureus* or *tuteus*, would be very odd, would it not? 8, 8, very good. 9's generally so (Standard-roses): nothing except *Nemophilus*, *Saponaria calabrica*, or small *Campumulas*, or *Lobelias*, or something very dwarf, should be planted under standard roses. But four of your 9's, the corner ones, would be a *Gloire de Rosamere* rose to be planted with each Standard, and be trained up to the head of the rose. 10 and 12 very good; 11 and 13 ditto, that is, each pair matches pretty well. Tuhs will not be in character at all where the Cypress stand; but Irish Yews will answer there better than the Cypress, as to effect; and they ought to be from 5 to 9 ft. high, not lower or higher for the particular situation. We must not write private letters even to young ladies.

SEEDLING GERANIUMS (1001).—You are certainly one out of a thousand; six whole pages, filled with what a lady from the Isle of Man would put into a quarter of a note page, shows how little you know of the nature of time or of human patience. Let your geranium seedlings go on just as they are, be they ever so gawky, till they bloom, or else they may take another year to prove them. A seedling is more likely to flower sooner in a three-inch pot than in the largest; pinching, stopping, bushyness, and all that sort of thing, is downright nonsense when applied to Seedling Geraniums. Geranium seeds do equally well sown with or without the "husk." You mistake the philosophy of gardening altogether. A gardener who could not tell why the Moss Roses come not from cuttings, ought to have asked you why the nightingale sings at night. In your next letter, let us hear your reason for the breast of the robin being red, or why ducks like water, while we know they would do as well without swimming.

WEIGELA ROSEA PRUNING (W. F. H.).—Full-grown plants of this beautiful shrub require the older wood to be removed annually, any time in winter, and to encourage young wood, which produces the best flowers. The young wood ought to be shortened as soon as the flowering is over; at the same time, very weak or very crowded shoots ought to be cut out altogether.

FORSYTHIA VIRIDISSIMA (Ibid.).—It flowers on the old wood like the white and red Currant, and it may be spurred-in exactly like them after it comes to a full size; but while it is in progress, cut only a few of the second-sized shoots about one-half their length, and the stronger ones pass by. Now is a good time to prune both. Many thanks for the brevity of your letter.

FLOWER-GARDEN PLAN (A. R. F.).—Your plan is very good indeed, and your style of planting still better. 12 and 33 are the only two beds we dislike, as the height of the plants (*Ageratum*) in them strikes off the view looking from either end. To keep to your own tints, we would plant them (12 and 33) with *Heliotropes*. *Humeus* in the centre of the figure, as you propose, will have a very fine effect, and better if you had them with three, four, or five stems from near the bottom for these beds; but when *Humeus* are planted as accompaniments to architecture, they look best trained to one stem. This plan is well worth engraving. The *Roses* now in pots, and which you want to bloom next Christmas, prune them now on the close system. See to the drainage, and then plunge the pots in front of a south wall or vine border; and in the hole under each pot place a 48-pot, with the mouth upwards, and on this open mouth place the bottom of your rose-pot: that is the best contrivance for good drainage, and for keeping out the worms. Keep the plants free from insects, and give liquid manure occasionally; prune again by the middle of September; and early in October place in a cold pit, and in November begin forcing.

CUCKOO FEATHER (Poultry-yard).—The enclosed feather, which we presume was taken from a hen, is a dusky specimen of *cuckoo* plumage. This marking, being found in both Dorkings and the common barn-door hybrid, will not be sufficient to determine the class to which your birds may belong; but the small tuft of feathers on the hen's head would appear to indicate some relationship with the Lark-crested fowl, a common inhabitant of homesteads, and highly esteemed for its laying properties. Specimens of one or two feathers can only serve to ascertain, and that, too, with no great accuracy, the distinctive colour and markings of a fowl. To assign a specific species requires particulars of form, habit, and other details, with which such queries should be accompanied. The rose-comb of the cock would strengthen the supposition of your birds being descended from the Dorking, as well as Lark-crested, variety; the male birds in the latter being usually seen with an upright single comb. We should be glad to know whether the chickens you may breed from these fowls revert to the characteristics of either of the races to which we have referred their origin.—W.

PEARS IN NORTHUMBERLAND (A Lover of Fruit).—*Beurre diel* has a rich and generous flavour when mellow, with a slight musky taste: when good, it is everybody's pear, and an enormous bearer. It should, probably, have an east or west wall in Northumberland. *Hucon's*, with you a similar situation, though you might try this as espalier. We do not know "The Green Park." *Fondante d'Automne* a similar situation to *B. diel*, and *Winter Neitis* should have a stout wall with you. As espaliers, try *Beurre d'Amouillis*, *Dunmore*, *Althorpe Crassanne*, and *William's Bon Chretienne*. Get them on the Quince.

FRUIT IN DERBYSHIRE (A New Comer).—Your elevation is great (1200 feet), and your climate we know. We would, however, by all means try our more hardy fruits, and with many you will succeed very well; but if you will take advice, we say, make platforms according to directions in our back numbers, the soil eighteen inches deep only for Pears. We should have Quince and Paradise, and should not fear Rivers' trees. Try dwarfs, by all means, and be prepared to cover them annually. In Apples, any of the well-known hardy kinds; in Pears,

Dunmore, *Beurre d'Amouillis*, *Beurre diel*, *Fondante d'Automne*, *Louis Bonne of Jersey*, *Soldat Laboureur*, *Flemish Beauty*, and *Glout Morceaux*. *Cherries*: the Duke's, *Elton*, and *Morello*. *Plums*: *Precose de Tours*, *Orleans*, *Royal Hatve*, and *St. Martin's Quetsche*.

PLANTS FOR A VERANDA (Ibid).—Try *Calampalis scaber*, *Lophospermum rubescens*, *Maurandya Barclayana*, *Tropaeolum aduncum* and *pentaphyllum*, the climbing *Roses*, *Honeysuckles*, *Clematis*, *Jasmines*, &c.

SHANKING (B. C.).—See an article by Mr. Errington.

ORCHID CULTURE (A Reader, P. D.).—You have entered upon a situation, and have some orchids committed to your care, but profess not to understand their culture, and ask what kind of soil will suit *Cattleyas*, and if the last year's bulbs should be cut off when this year's are half grown of *Dendrobiums* and *Cattleyas*, when the leaves decay? You ask these questions because some gardener has told you that *Cattleyas* require a rich soil, such as half-decomposed tree leaves, and half-decayed branches of trees, broken into small pieces, and that the year-old shoots of *Dendrobiums*, and the back bulbs of *Cattleyas*, should be cut off. We have thus extracted your questions in order to answer them succinctly. *Cattleyas* do not require such stimulating compost as your friend recommends. The finest specimens in England are grown in simple fibrous peat, with all the fine particles beaten and sifted out. Then, the back pseudo-bulbs? Unless wanted for increase of the number of shoots in one pot, or for increasing the number of plants, they need not be cut off; in fact, they strengthen the leading shoot or pseudo-bulb greatly. The last year's shoots of *Dendrobiums*? These, in many varieties, are the ones to flower, very few flowering upon the same year's pseudo-bulbs; so that to cut them off would be an act of madness. The heat of your house is almost too low for *Dendrobiums*, but right enough for *Cattleyas*. *Cattleya Aclandiae* is a delicate little growing species, extremely scarce, and difficult to manage. Keep it on the block, as also *C. marginata* and *C. pumila*. *Cattleya superba* would improve, if it, and the block on which it grows, were planted in a pot filled with very fibry peat and broken potsherds; the block to stand above the pot-edge three or four inches.

PLACE FOR A PIGEON-HOUSE (An Amateur).—Your proposed site for a pigeon-house, about six feet cube, represents, we imagine, a *loft* of that size. Well-ventilated, and the birds allowed their liberty when once reconciled to their new abode, twelve pair would be commodiously settled there. Egress should be given at the south end, the entrance being opposite. Shelves, as were described in our number of February 3rd, with earthenware saucers for nests, will be all the furniture you will require. The south front should have a stage, which may at times be closed in with a latticed front, to confine your birds; and this trap should act with a cord and pulley. As to the selection of sorts, our own experience would point out Trumpeters, since profit is what you aim at; they are as productive as any variety, and attain a large size. If well-fed, each pair should rear, on an average, nine or ten young ones annually.—W.

ROYAL AGRICULTURAL SOCIETY'S GLOUCESTER MEETING (J. T. R.).—This Society will have an improved list of prizes, we hope, at Gloucester. One of the Committee writes as follows in *The Midland Counties' Herald*:—"The Council, on the motion of Mr. Jonas, seconded by Mr. Brandreth Gibbs, voted the sum of £100, as the amount of prizes to be offered at the Gloucester Meeting, for improving the breeds of poultry best adapted for the purposes of the farmer; and referred to the committee of last year the report with which the Council had been favoured by the Society's Judges of Poultry at the Lewes Meeting (the Hon. and Rev. Mr. Lawley, Mr. T. B. Wright, and Mr. John Baily), with a request for recommendations on the subject of the particular prizes to be offered in this department. We have not yet seen the list of prizes for stock, but we believe they will be issued immediately. We congratulate poultry amateurs on the very liberal vote of the Council for the purpose of encouraging the improvement of domestic fowl; and, should the prize list prove to have been judiciously framed, we have no doubt this part of the exhibition at Gloucester will show a marked advance as compared with what was witnessed at Lewes in July last. The importance of poultry as a source of profit to the farmer having been recognised by the most influential agricultural society in the world, we may hope to see a rapid improvement in the appearance and quality of the feathered tenants of our farm yards. In this case, as in all others, it is good stock only that is profitable; and the farmers who shall displace the unhappy race of nondescripts, now seen almost everywhere, for pure-bred Dorkings or Hamburgs, will find their advantage in the increased value of the produce. As the *Times* has very properly shown, it is a matter worthy of attention that our markets should be supplied with better and cheaper poultry and eggs; and it will be obvious, that what is profitable in France would, if pursued with the same care, be still more so in this country, where a much higher price can be obtained. It must, at the same time, be admitted, that there has never been a movement connected with rural economy which has so rapidly sprung into importance as that of poultry-keeping; and this is mainly to be attributed to the establishment of an exhibition on a large scale in this town—conducted on sound principles, and in the progress of which the promoters have sought the valuable co-operation of those whose experience and position enabled them to render great practical assistance. The step from the first small show in a corn-loft, in Worcester Street, to the wonderful display in Bingley Hall last December, has been the work of but four short years; and there can be no question as to the utility of an undertaking which has not only obtained so large a measure of support for itself, but has been the example on which similar meetings have been already established in nearly every district of the kingdom."

WEEKLY CALENDAR.

M D	W D	FEBRUARY 24—MARCH 2, 1853.	WEATHER NEAR LONDON IN 1852.				Sun Rises.	Sun Sets.	Moon R. & S.	Moon's Age.	Clock bf. Sun.	Day of Year.
			Barometer.	Thermo.	Wind.	Rain in In.						
24	Th	Clouded Brown; oaks.	30.500 — 30.362	42—31	N.E.	—	59 a. 6	29 a. 5	6 a 26	16	13 28	55
25	F	Clouded Lead; oaks.	30.333 — 30.205	45—29	E.	—	56	31	7 47	17	13 19	56
26	S	Rosy Day Moth; hedges.	30.334 — 30.225	43—33	N.E.	01	54	33	9 9	18	13 8	57
27	SUN	3 SUNDAY IN LENT.	30.136 — 29.963	46—32	N.	01	52	34	10 35	19	12 58	58
28	M	Curve-dotted; hedges.	29.715 — 29.628	50—30	N.W.	01	49	36	11 58	20	12 46	59
1	Tu	David.	29.803 — 29.710	49—34	W.	—	47	38	morn.	21	12 34	60
2	W	Peacock; lanes.	29.850 — 29.749	49—19	N.E.	—	45	40	1 21	22	12 22	61

METEOROLOGY OF THE WEEK.—At Chiswick, from observations during the last twenty-six years, the average highest and lowest temperatures of these days are 48° and 35.1° respectively. The greatest heat, 64°, occurred on the 28th in 1840; and the lowest cold, 16°, on the 25th in 1844. During the period 99 days were fine, and on 83 rain fell.

BRITISH WILD FLOWERS.

POPPYWORDS.—PAPAVERACEÆ.

(Continued from page 375.)

GLAUCIUM.—HORNED POPPY.

GLAUCIUM CORNICULATUM: Horned Glaucium; Red Celandine; Red Horned Poppy.



Description.—It is an annual. The whole plant of a milky-green. *Root* spindle, or carrot-shaped. *Root-leaves* grow in a circle on short stalks; cut in sections down to the mid-rib; sections alternate, indented at the ends; the upper sections largest, and the end one broad, blunt, with three or four indentures, hairy. *Stem* about eighteen inches high, slightly hairy, hairs spreading; furrowed, with branches in two ranks. *Stem-leaves* cut into sections, half-stem clasping, alternate. *Flower-stalks* at the ends of branches, and springing from between a leaf and the branch, slightly hairy, with, sometimes, one or two leaves on them resembling those on the stem, but smaller. *Calyx* very hairy, oval, and rather pointed. *Petals* oval, scarlet, with an oval dark purple spot at the base, veined; soon falling off. *Seed-pod* very long, nearly straight, very hairy, or rather bristly, the bristles stiff, close pressed, and pointing upwards; terminating in a blunt knob. *Seed* round, and black.

Time of flowering.—June and July.

Places where found.—Lobel found it in the Isle of Portland, and Mr. Stillingfleet found it in sandy corn-fields in Norfolk. It has never been discovered since.

History.—It has been variously named by botanists *Papaver corniculatum phœniceum*, &c.; *Chelidonium corniculatum*, and *Glaucium phœniceum*. This last name, or Scarlet Glaucium, is the most characteristic, for *corniculatum*, or horn-like podded, applies to the whole genus. Ray says that it has but little yellow juice. It is common in most parts of Europe, but whether really a native of England is doubtful. We are not aware of any botanist now alive who has seen it wild in this country. (*Martyn. Smith. Ray.*)

WE have always held that the cultivation of fruit in this country has not received that attention which the importance of the subject demands: and in reviewing, as we have done in our former articles, the history of the orcharding of the past three centuries, we have seen that, instead of forming a permanent and systematic branch of rural economy, it has been allowed to wax or wane according to the ever varying taste of the various periods to which our attention has been directed.

Our firm belief is, and we have the evidence of the past to confirm it, that the cultivation of fruits, if judiciously and well practised, is much more important and profitable than in the present day it is generally considered to be. We have shown that for centuries past there have been, at certain periods, great movements in this direction; numerous and extensive plantations were formed, but in time they were invariably allowed to fall into decay, and no succession provided till urgency compelled it, and then, in many instances, it was too late. We have seen that at the close of the war in 1816, notwithstanding the high prices at the time, the demand was greater than the supply, and foreign fruit

was imported to such an extent, that the few growers which there were became so alarmed as to apply to government for an increase of duty. This they obtained, and, as will be seen from the tables at page 357, the importations decreasing from 1819, the supply would become less still. From 1819, a great system of planting was commenced, and carried out to such an extent, that in 1838 the breadth of orchard land in the county of Kent alone was upwards of 15,000 acres. Now, taking these 15,000 at 100 bushels per acre, which is allowed to be the produce for an average of years, it will give 1,500,000 bushels. Yet, notwithstanding this seemingly enormous average quantity from the county of Kent alone, when the orchards were in the highest state of productiveness, and before the displanting consequent on the removal of the 4s. duty, in 1838, had commenced, the value of the apples imported in 1839, as shown in the table below, amounted to no less a sum than £43,866 13s.; clearly showing that, even then, the home growth was insufficient for the consumption, even at the average price of 5s. 6d. per bushel.

In 1838, the duty of 4s. was removed, and one of

5 per cent. *ad valorem* substituted. This called forth strong remonstrances from the growers, who represented that nothing but ruin would befall them; that they could not maintain their orchards and their population; and that the total extinction of both must be the consequence. This became a subject for parliamentary inquiry, and a committee was appointed to investigate the subject. Thirty-five witnesses were examined, and out of these only four or five were in favour of the alteration. In the evidence before this committee, it was stated that the remunerating price to the grower would be from 3s. 6d. to 4s. per bushel. One witness was of opinion that, taking the average of years, 3s. would be ample remuneration. Judging from the evidence before this committee, the main object the powers had in view was to induce the government to believe that, from the comparatively low prices arising from large crops obtained between 1832 and 1837, it would be impossible to continue their plantations unless the protecting duty was restored. They were, however, unsuccessful, and many of them, in their visions of despair, did actually begin to displant, some to the extent of eight and ten acres, supposing they would never again see their remunerating average of 4s. But, notwithstanding the great reduction of duty, we find, from the table subjoined, that the price has been actually greater since than it had been for 13 years previously.

In 1843 the duty was altered to 6d. per bushel, at which it still continues; and what has been the consequence? We find that in 1846, with an importation of 292,427 bushels, the average price in the markets was 8s. per bushel, or 4s. more than the most sanguine expectation of the most doleful witness could possibly have reached; and that in 1850, with an importation amounting to no less than 467,629 bushels, the average price was 5s. 6d., or 1s. 6d. more than any other doleful witness would have been satisfied with. Now, what we want to know is, why do the orchardists and occupiers of land in this country allow 467,629 bushels of foreign apples to be brought into our markets, when an average price of 5s. 6d. can be obtained for our own growth of that article, and for which 4s. is a remunerating return according to their own statement?

Here, again, we are forced to remark on the total disregard to the importance of treating orchards as a branch of rural economy. We hear of Agricultural Societies, and Horticultural Societies, Cattle Shows, Poultry Shows, and Flower Shows; and what would the cattle, and poultry, and flowers of this country have been, were it not for these societies, and these shows? But why is it we hear nothing of Orchard Societies, and Fruit Shows? Why of no premiums for the best cultivated orchards; the best grown fruit; nor for the best essay on the adaptations as to soil, climate, and use of the best varieties of fruit? Surely these are subjects worthy of attention in this age of progression and improvement. Look at our increasing population, and increased consumption of all kinds of produce; the facilities of communication from one end of the country to the other; the comparative luxuries that our mechanics, artisans,

and labourers now enjoy; and contrast this with the low, limited, and laggard state of our orchard cultivation; it would seem that in proportion as other pursuits progressed this was retrograding. It is not from choice that our mechanics and artisans consume these 467,629 bushels of foreign apples, tainted and worthless as they generally are, but it is because there are some 4000 or 5000 acres less of orchard produce of our own, that they are compelled to do so. Now, there must be in this country some 4000 or 5000 acres of land in the condition of that on which one of the witnesses gave the following evidence:—

“Q. If you could have let your land without any difficulty as a fruit plantation, at £5 an acre, what do you suppose you could let it at to grow corn?—A. It is very light land, on a hill, and stony; I should have great trouble to get £1 an acre for it to grow corn.”

And as regards the quality of this foreign fruit, we again quote part of the evidence already referred to, as given by a witness who fought hard for the old duty. How he supported his views will be seen from the following:—

“Q. Will not the effect of the introduction of foreign apples be to lower the price?—A. Yes.

“Q. Then will not the poor have the foreign apples at a lower price; and, of course, will they not consume them when they are brought in?—A. They are hardly worth consuming, half of them; they are scarcely worth eating.

“Q. Then, if they are not consumed, the English apples will come into consumption; must we not suppose that the English consumer, finding that the French are not worth eating, will consume the English?—A. I suppose they must.

“Q. How will they consume the English, if they have ceased to exist?—A. I am supposing that they have not ceased.

“Q. But supposing this alteration of duty should discourage the English planter of orchards, and the present orchards fall into decay, what becomes then of your supply?—A. You have no other way of getting a supply but from France; and in the event of a war how are you to get that?

“Q. But, if the French supply is so very bad, the English consumer will not take it, and the English orchards will not go out of growth, will they, because it will be worth the while of the English grower to keep them up?—A. It will reduce the price.”

In drawing our observations to a conclusion, we would remark that, from what we have stated, it will be seen that this is a subject calling for special attention. Hitherto it has been neglected among us; we do not seem, in this country, to be alive to the importance of it: but it is not so elsewhere. We know that in America there are Societies formed for the purpose of directing and encouraging it. In France and Germany it is regarded as of paramount importance, and in Belgium it is honoured by the patronage and support of the Government. Can nothing be done here? Can no Society be organised to aid on and give direction and

counsel in this work? Let us trust it may be so, and that ere long we shall have such an one as will take its position with those others which our country delights to honour. H.

Quantities of Apples Imported from 1838 to 1850, with the average Prices in Covent Garden Market.

Year.	Duty.	Quantity imported.	Average price at Covent Garden.
1838	4s	2,162 bushels	4s 6d
"	£5 per cent.	£33,395 12s 3d	4 6
1839	ad. val.	43,866 13 0	5 6
1840	£5 5s	33,717 13 5	3 6
1841	per cent.	40,849 0 0	4 6
1842	ad. val.	6,644 0 0	4 6
"	6d	111,586 bushels	4 6
1843	6d	314,954 "	6 6
1844	..	182,590 "	6 0
1845	..	197,061 "	6 6
1846	..	292,427 "	8 0
1847	..	331,073 "	4 0
1848	..	243,034 "	5 0
1849	..	323,719 "	3 6
1850	..	467,629 "	5 6

RENEWING our notes on Landscape-gardening, we now proceed from the "Approach," the subject of our last paper, to a consideration of those principles which should govern the direction and character of the various *Walks* requisite, whether about the grounds of the country mansion or the villa.

It may here, however, be observed, that neither the width nor the style of walk is in these two cases obliged to be the same; they will occasionally have to differ much, inasmuch as the dimensions, the locality, and other concomitants, will of necessity vary. It will, therefore, be well, perhaps, to handle the subject of Villa walks in a separate form, although, in the mean time, it may be understood, that in the main the chief principles are applicable to either style.

One of the first things to be thought of, is to provide an extent of mere perambulation, commensurate with the requirements of the family, and the chances offered by the grounds. But, then, the great consideration is, how to take in agreeable and legitimate objects, so as to keep the interest of the perambulator constantly on the alert. Now, it will not be expedient so to present views as that the eye may pierce through and discover a limitation of extent, giving an impression of meagreness. This is above all to be avoided; but this remark applies principally to the suburban retreat or the villa. It is the business of the planner so to conduct his principal walks as to keep interest alive without showing too much of his picture at once, and without the affectation of fighting against the genius of the ground.

Convenience alone points to the propriety of at least one principal walk, and proceeding from that side of the house, if possible, where the noblest rooms are situate. In the modern villa, or suburban residence, to accomplish this is sometimes difficult, but in the case of great mansions in the country, possessing, it may be, a park with far stretching pleasure grounds, the case is somewhat different.

In the former, severe limitation of space, together with

the habits of the occupants, combine to press the propriety of being content with one principal line. But in places of high pretension, free from boundary lines hard on the eye, a much greater degree of latitude may be allowed. The terraced frontage, the pasture or flower-garden, or the kitchen-garden, may demand special walks, ruled, of course, by the circumstances of the mansion, and the site of the respective plots; but, nevertheless, proceeding from the drawing-room front.

And, now, as to the width of walks. We hold it good practice, in most grounds, to have two distinct widths, and in some cases three. Assuming, therefore, three characters of walks, it will be well, in order to keep matters distinct, to give them names descriptive of their character and uses, and we offer the following as illustrative of what is meant, viz.: the PERAMBULATING, the EPISODICAL, and the SUBORDINATE. It will, doubtless, be remembered by many of our readers, that the *Episodical* was a favourite appellation with the late Mr. Loudon, who was one of the first to simplify landscape gardening.

In order to exemplify those three classes, we may suppose a case, in which one principal walk passes round the whole grounds, and that the Rosary, the American garden, &c., lie at little distances from its sides as by-plots, the walks to them diverging at nearly right angles, as they should do; these we would class as *episodical* walks. Again—suppose that such episodes required a plant-pit, a small tool-house, &c., concealed by dense shrub masses, the walks to these we would class as *subordinate*.

Admitting, then, three classes of walks, let us come to their respective widths. It may here be repeated, that the country mansion, and the little suburban retreat, may, and must, occasionally differ in this matter, inasmuch as very broad walks, in very limited places, would neither comport with the principle of proportion, nor a just economy in the distribution of the limited space. This premised, we will deal with the mansion of ample grounds, and this will constitute an aim for the villa proprietor; a point to reach as near as he can. It is common with most landscape gardeners to require seven feet in width for the chief or perambulating lines, inasmuch as this is the minimum width requisite for three persons to walk abreast, and this is often a great desideratum as to social converse. Now, although our great landscape men may not have recognised precisely such widths as we must here propose, yet, having fully considered the matter, we must suggest sixty-six inches for episodical walks, and let us say three feet for the subordinates.

As for terrace lines and promenades, instituted for effects sake, they form an exception, and must be dealt with accordingly. Very narrow walks have been much repudiated by our landscape gardeners of celebrity, and justly so; but a mere enunciation of abstract principles will not meet the spirit of our times; principles right enough, it may be, in their essence and character, must and will be highly modified both by economy and expediency. The business is, so to handle arrangements as that no great principle be extravagantly compromised;

all trifling departures from dry rules will then be readily pardoned on the basis of expediency.

We come now to the *direction* of our walks. It has been said, by authorities somewhat high in landscape gardening, that very sudden turnings ought to be avoided. Turnings, the pretensions of which at once appear as an affectation of fine lines, without existing features to stamp a meaning on them, we repudiate; but shall this be counted a valid objection, or shall such a rule tie the hands of the landscape gardener?

Now the bends in walks, we admit, are not very important matters in themselves, although it must be granted that there are ugly curves as well as beautiful ones; still, it is well not to lay too much stress on the character of the curve in itself, inasmuch as we have known schemers grievously misled in their plans by suffering these fine lines to absorb their attention too much. "With leaden eye that loves the ground," has been used as a sarcasm ever since Pope's days, and it applies tolerably well to this class of schemers, whose proper title should be ground workmen, instead of landscape gardeners. Certainly, where entirely new gardens are to be made out of a naked field, and no trees exist, it is another affair. But in improving grounds of some age, and where lines have to be formed among existing trees, and other objects, the true landscape gardener will be thinking more of the sky line than the ground line; he will closely study the existing objects, and so group them overhead as to make it appear that the line, when complete, could not have been anywhere else.

But to return to the ground line. We must confess to a particular liking for bold curves or sweeps, in some cases almost abrupt. It is considered one of the fundamental principles of landscape gardening so to manage the picture as to keep the mind of the perambulator constantly employed, and sometimes to take him by surprise. This cannot be done by straight lines, or by tame curves, for concealment becomes occasionally necessary.

"Let not each beauty everywhere be spied,
Where half the skill is decently to hide."

To concealment we must here add another great landscape essential—intricacy of outline; a principle equally desirable in large grounds and small: in the former, as taking away baldness of appearance, and adding to the interest; and in the latter, giving apparent extent and importance.

The bold sweep or curve, then, is admirably adapted to this end, for the bolder the sweep the bolder will be the style of planting contiguous to the lines, and thus that partial concealment is accomplished which, as before observed, by not presenting too much at once to the eye of the perambulator, keeps his mind continually on the alert. We may here remark, that it is considered indispensable that every bend should have an object either existing already, or placed there to render the whole reasonable. Without this, bold, or rather bald curves, are unbearable, and appear as laboured attempts to create effect by mere lines alone, or as sheer affectation. A judicious planner, therefore, in grounds where

old trees, huge evergreens, or other permanent objects exist, will take care to make use of them occasionally, by carrying his line sweeping round such objects, if massive enough to effect the desired concealment.

Some of our planners have made a point of taking in, occasionally, any huge or noble tree, if it happen to stand near the line; this, made a centre, and the walk made to sweep round it right and left, sometimes produces good effect, and helps variety, that great essential to lasting effect.

A circular seat may be made to embrace the tree, especially if the grounds in the vicinity of the tree present a pleasing picture. It is a generally established maxim not to allow two curves to be seen at once, and this principle must be, if possible, carried out by planting, &c.

Care should be taken not to force the lines of walk too close to the exterior or boundary, although we see no reason why, in extensive grounds, it may not be so managed, when a fine champaign country, embracing dignified views, and free from hedge-rows, affords an opportunity of giving a short relief from the contrasting character of the ornamental grounds.

One thing more we may point to, and that is, in selecting the lines of walk, occasional undulations should be sought; the walks should at times be made to ascend for variety's sake—such are always more cheering to the perambulator than those confined to a dull level, and afford excellent opportunities for giving variety to the style of planting, &c. Indeed, variety, as before observed, must be ever sought, and mannerism avoided. As terraces and geometric lines do not belong to this class, we must include them in another portion of the subject.

E.

COVENT GARDEN.

THE market still continues to display an abundance of every kind of vegetables, but the supplies of fruit are falling off. The greatest attraction is the profusion with which the windows are adorned with cut flowers, which are now more numerous and gay than at any other season. Plants in pots are not so plentiful, chiefly on account of the frost which has been so prevalent during the past week.

The prices of VEGETABLES continue very much the same as for the last few weeks. *Savoys* are still plentiful at from 6d. to 1s. per dozen. *Greens* also at 1s. to 2s. per dozen bunches. *Brussels Sprouts*, 1s. to 2s. per half sieve. The supply of *White Broccoli*, from Cornwall, is also good, and makes from 2s. to 3s. per dozen, according to the quality. *Turnips*, 1s. to 2s. per dozen bunches. *Carrots*, 2s. 6d. to 3s. 6d. *Celery*, 9d. to 1s. 6d. per bundle. *Onions*, 2s. 6d. to 3s. per bushel. *Spinach*, 1s. to 1s. 6d. per half sieve. *Lettuce*, from 6d. to 1s. 6d. per score. *Endive*, 1s. to 1s. 6d. per score. *Potatoes* are plentiful, more so than they have been for some weeks past, and the price is if anything lower; but good *Regents* still make as high as £7 10s. *Rhubarb* is plentiful at from 9d. to 1s. 6d. per bundle. *Sea-kale*

is also plentiful at from 1s. 6d. to 2s. per basket. *Asparagus* is much improved in quality, and makes from 4s. to 7s. 6d. per bundle.

The supply of FRUIT is falling off. APPLES are making from 6s. to 10s. per bushel for culinary varieties, but the dessert realise from 8s. to 16s. Of the culinary kinds, the *Winter Pearmain* is the most plentiful; firm, and of excellent quality. Among the dessert kinds we observed several parcels of very fine *Court of Wick*, which were not, however, so highly coloured as we have seen them. *Golden Knobs* also fine; and we were attracted by a pile labelled Nonpareils, which, on examination, we found to be the *Reinette Grise*, a French apple, which is imported rather largely at this season. Though this is a pretty good winter dessert apple, it will not pass for a Nonpareil with those who know what a Nonpareil is. There are also plenty of the *Lady Apple* and *Newtown Pippins*. PEARS, as we have remarked before, are very scarce, just sufficient to say that they are in existence. Such as they are, though dry and shrivelled, they make from 6s. to 8s. a dozen. They consist of *Beurré de Rance*, *Easter Beurré*, and *Ne plus Meuris*.

The Flowers and Bouquets are both gay and abundant. We promise our lady readers that we shall take the first opportunity of admitting them to the art and mystery of building a bouquet. We have been at some pains to acquire this art ourselves for their benefit, and we trust ere long to be able to communicate it. The FLOWERS consist of *Camellias* of all shades and markings, *Cinerarias* of every hue, *Hyacinths*, *Tulips*, *Polyanthus*, *Narcissus*, and a profusion of double and single, white and red, *Chinese Primroses*; *Violets* in abundance; *Scarlet Geraniums*, *Snowdrops*, *Lily of the Valley*, *Eparcris*, *Pentus carnea*, *Bletia Tankervilleæ*, *Azalea indica alba*, and *Danielsiana*.

H.

GOSSIP.

WE ask our readers attention to the advertisement of *The Horticultural and Pomological Association*, for it is to them that it owes its birth. So very numerous are the applications to us from all parts of the British Islands, requesting us to procure seeds, cuttings, trees, and other objects of cultivation, that we find it quite impossible to attend to the commissions thrust upon us. In future we request that all such applications may be made to the Association. Competent parties, we know, are engaged to procure whatever horticultural matters the subscribers may require; and acting, as they will, under such supervision as will be given by Mr. Hogg, the author of "British Pomology," and Mr. D. Beaton, the one the best of practical fruitists, and the other one of our best gardeners, the subscribers may be sure of no deficiency of skill being employed in their behalf. We have reason, also, to anticipate that the Association will be the means of determining many synonymns of fruits, and whatever is thus effected will be published in our pages.

The *Newbury Horticultural Society* has fixed its

meetings in the present year on the 24th of June and 2nd of September.

The *Limnocharis Humboldtii*, a yellow-flowered aquatic, native of Brazil, has been hitherto considered as requiring stove culture, but it has proved hardy in an open pond at Berlin, where it was blooming early in December. There is no doubt, therefore, that it may be cultivated in England as a hardy aquatic.

The value of *Shanghae fowls* is rising rather than decreasing, and we have no doubt that as the knowledge of their quiet habits and other valuable qualities becomes more diffused, the demand for birds of high quality will increase, and the prices, consequently, be maintained. Our opinion is sustained by the result of the sale of some of the Shanghae stock of T. H. Potts, Esq., of Kingswood Lodge, near Croydon. This sale was by Mr. Strafford, at the Baker Street Bazaar, on the 10th inst., and although a very large proportion of the lots were small-framed birds, yet the 121 realised the large sum of £723 8s. 6d., notwithstanding some of the cockerels, very inferior, were knocked down for such sums as twelve and thirty-two shillings. Lot 8. A black cockerel, bred by Mr. Lort, and took a first prize at the Great Metropolitan Show, sold for £8 10s. Lot 21. A lemon pullet, which took a first prize at the Bristol and Metropolitan Exhibitions, sold for £13 13s. Lot 26. Lemon cockerel, which took the first prize at Bristol, for chickens hatched subsequently to the 24th of June, £5s 5s. Lot 29. Buff hen, which took a prize at Birmingham, in 1851, £12 15s. Lot 35. Lemon cockerel (Wellington), which took prizes at the Great Metropolitan and Torquay Shows, £28 7s; another cockerel (Lot 69. "Sir Robert.") sold for £42; he was purchased by Earl Ducie. Lot 53. A hen for £22, to Mr. Baily; and Lot 52, a hen imported, formerly belonging to Mr. Andrews, described in the catalogue as "having taken many prizes, and considered the best hen in England," was purchased by Mr. Fox, of Snow Hill, for £36 15s. Lot 102. A hen which took a prize at the Great Metropolitan and Torquay Shows, £23 2s.

BULBS.

(Continued from page 363.)

CUMMINGIA.—This is a genus of Lilyworts belonging to the section of *Conanthers*. Formerly it was united with the genus *Conanthera*, and I believe that the difference between the two was first pointed out to the late Mr. D. Don, by the late Lady Gordon Cumming, whose name the present genus is intended to commemorate. The species are all natives of the north of Chili, and are difficult to flower, or to be kept in a flowering state; they should be grown in pots, and in poor sandy loam. The herbage is delicate, and the flowers are of the richest dark blue colour, such as some varieties of the Hyacinth represent; and the shape and size of the flowers are between that of a single Hyacinth and a Scilla. I believe the roots (they are not true bulbs) would succeed better in small shallow pans than in deep pots, so that they would receive the benefit of a scorching heat, while the leaves and flowers enjoy a dry, airy, or open air culture, in our climate.

CUMMINGIA CAMPANULATA.—This is the species on

which the genus was founded by Mr. Don. It is figured in *Sweet's British Flower Garden*. It begins to grow late in May, and flowers for two months in the autumn, and goes to rest before midwinter. It is increased by dividing the roots like an *Alströmeria*, but the more they are allowed to bundle together the safer they are; all of them are, evidently, from a poor dry soil, where the few showers that fall to their lot, during the whole circle of their existence, affect them but in a very small degree, and their low, tender herbage seems rather to be nourished by the fogs and heavy dews which are peculiar to the sea-side plains in the north of Chili. Bulbs, and other plants, natives of a similar climate in South Africa, and in some parts of Mexico, and in other places that are refreshed with periodical rains, send their roots far and deep into the soil in quest of moisture; while those on the lower plains in the south of Peru and the north of Chili, where rain, if it ever falls at all, seldom penetrates beyond an inch or two, root near the surface. Hence the reason why bulbs from this quarter fail with us when we encourage their roots to penetrate deep into our loose borders, away from the influence of the sun, which is more natural for them; and hence, too, my reason for recommending an opposite course for them. I would allow a free course for their roots on all sides, but I would prevent them from going down beyond two or three inches, according to the size of the bulb, by placing a close surface of soft porous bricks or sandstone under them, which I would keep constantly moist while the bulbs were in growth; and this can best be effected in a pit; and, when the bulbs were at rest, I would keep the glass constantly over them to increase the temperature and dryness about them. If the artificial bottom were placed on damp clay, all the better, as the great heat in the pit during the dry season would not dry up suddenly the moisture from the bricks; or, if it did in part, there would be a constant supply of moisture from the damp clay below; and we know that some of the large bulbs from the Cape enjoy a damp bottom to their roots all the time they are at rest. For that purpose, many good cultivators place their pots of these dry bulbs in saucers of sand, which they keep constantly damp.

CUMMINGIA TRIMACULATA, and TENELLA. — Both of these are very dwarf plants flowering in the autumn. The flowers of *trimaculata* are the darkest blue of the three, and the flower-spike or stem branches a little like that of a little *Anthericum*, a genus to which they are nearly related, so much so, that Persoon, a good bulb authority, mistook a little yellow-flowering plant from Mexico (*Echeandia terniflora*), with the very aspect of *Anthericum*, for a *Conanthera*. The three species require exactly the same kind of treatment, such as is indicated under the first species.

CYANELLA. — This is a small tribe of very old-fashioned plants, chiefly from the Cape, and are about as hardy as *Ixias*, and much about as large as the middle-sized species of *Ixia*, or say from ten to fifteen inches high, but they are not true bulbs, although they are Lilyworts. They belong to a large section of the order, once called after the *Asphodels*, but now, more generally, after the *Anthericums*. There is hardly a plant in this section with a true bulb. Yet all of them exhibit the aspect of real bulbous plants, and as such they are set down in most of our books.

CYANELLA ALBA, with white flowers; ODORATISSIMA, with rosy flowers; and ORCHIDIFORMIS with light blue flowers, are the best species for shows, and also for giving diversity of colours peculiar to the genus. They require opposite treatment to the *Ixias*, as they rest all the winter, begin to grow late in the spring, and flower at the end of summer. With a little care and management at first planting, and by keeping together all the half-hardy bulbs that grow and bloom in summer, and go dry in winter, the whole lot of them may be grown

and flowered in any part of this country, and with much less trouble than in keeping common Scarlet Geraniums: all that is necessary, is to keep the rain from this border from the end of October to the middle of March, so that it is as dry as powder by that time, then the merest protection in very frosty weather will keep it safe, and by the end of March the border should be forked with a gentle hand, a few inches deep, and three or four good heavy waterings from some open pond, so that every particle from top to bottom should be thoroughly wetted, like the ball in a pot. A bulb-border should be arranged and filled-in just as you would a large pot—perfect drainage at the bottom, rough peat, and turfy loam, pieces of porous stone, lots of bones broken to a few inches in length, but not crushed. As much of charcoal in pieces not bigger than a dove's egg, all mixed together till you come within six inches of the top, then smother peat and loam, or whatever your bulbs like best.

CYCLAMENS.—The cultivation of these has been given repeatedly in THE COTTAGE GARDENER, and the means of improving them have also been fully detailed, if I recollect rightly. Like the *Tigridia*, their improvement is going on very slow indeed, but still on a sure basis, and I do not know that I can add any more to them now.

CYCLOBOTHRAS.—This genus of small flowering-bulbs stands in the same relationship to the elegant *Calochortus*, as *Collania* does to *Alströmeria*. They have nodding or drooping flowers, hanging down from the top of scapes, from eight to fifteen inches high; some of them, as *alba* and *pulchella*, were once included among the *Calochorts*. The genus was founded by Don, not by Sweet, as is supposed. Sweet only figured some of the earlier introduced species in his *British Flower Garden*. The same directions which were given for *Calochorts* are applicable to this genus also; but there is no difficulty in flowering any of the *Cyclobothras*, nor in keeping them, and most of them seed so freely, that they could be increased to any extent. All bulbs which droop like these should be planted where they could be seen above the eye, if that could always be done; peat-borders, or very light sandy soil suits them, best.

CYCLOBOTHRAS ALBA.—The nearest plant of any of our common bulbs, to compare to this family, is the little yellow Florentine Tulip which we force with other spring bulbs. The flowers of this *alba* are about the same size as those of this Tulip, and the plant altogether is about the same height and size.

CYCLOBOTHRAS BARBATA.—This, the *Fritillaria barbata* of Kunth, is a very pretty yellow-flowering bulb from Mexico, requiring greenhouse culture in a pot. But as it goes to rest early in the winter, and is not very delicate nor difficult to keep, it will do very well in a border of mixed *summer-growing* bulbs. It flowers from the end of summer, for two months, and a strong-established bulb, in a light, deep border, will throw up a strong scape two feet high. The flowers are much bearded or hairy in the inside—a feature not uncommon to all of them, and to the *Calochorts* also.

CYCLOBOTHRAS ELEGANS.—A very dwarf species with white flowers, quite hardy, and succeeds best in peat—say a peat border. It is one of Douglas's *Calochorts*, and is missed in our Dictionary; and there is one called *lutea* in the Dictionary, which I do not know, unless it be

CYCLOBOTHRAS MONOPHYLLA.—A very dwarf plant with small yellow-bearded flowers. This kind was discovered by Mr. Hartweg, on the Sacramento Mountains, in California. It is quite hardy, and not difficult to keep.

CYCLOBOTHRAS PULCHELLA.—This is also a yellow-flowering bulb, with greenish sepals, and there is a delicate fringe on the bright yellow petals. It is a very pretty flower; the plant rises a foot or more, and is one of the easiest of them to keep, and to increase, as it seeds abundantly in the autumn.

CYCLOBOTHA PURPUREA.—A very old-described bulb, and one of the best of them, and also one of the tallest; about the same size as *barbata*. It is a native of Mexico, and not quite so hardy as the more northern ones. *Barbata*, *pulchella*, and *purpurea*, are the three best, but they are all well worth growing, as their mode of growth, and of showing off their drooping flowers, would make a pleasing variety on a rich border of miscellaneous bulbs.

CYPELLA.—With very much of the aspect of *Tigridia*, and with smaller flowers and longer scapes, in some instances (*plumbea*, for instance). The *Cypellas* have the flowers still more fugacious than *Tigridia*. The same treatment in every respect will suit the two families; and also the *Rigidellas*, *Beatonias*, and *Hydrotenias*. It is as likely as not that some of these will, one day or other, be found to be nothing more than sections of the *Tigridias* after all; greater marks of difference may be discovered any day between sections of other families that interbreed very freely. Without some such mixture of blood the *Cypellas* are not worth much, but the vermilion hues of *C. Herbertii* are very rich, while that of *C. Plumbea* is very curious. *Herbertii* is the best of the three, *Drummondii* the next, and *plumbea* the third.

CYRTANTHUS OBLIQUUS AND CARNEUS.—The first is very well figured in the *Botanical Magazine*, 1183; and *carneus* equally so in the *Botanical Register*, 1462. They are all of this genus that I shall speak of to-day. They are both evergreen, and the only evergreens known to us in the genus. Their leaves are much alike: thick, firm, and very blunt at the ends; the bulbs are considerably larger than those of the *Belladonna*, and they are very difficult to grow, and to increase, without the exact kind of loam they like. The yellow loam from Wansted Common, near London, suits them remarkably well, with only a very little sand added to it. Mr. Wheeler, of Warminster, used to grow them very healthy many years ago, but Dr. Herbert could never succeed with these two. I have been more successful with them than any one here, or in Australia, where they are quite at home. Once in seven or eight years will do to repot them, and they must have as small pots as they can be got into. They delight to be in a strong draught all the year round, where the air is admitted in the front of a greenhouse from May to October; and in the front of a late vinery, where the air is kept quite dry all the winter, and at a temperature from 45° to 50°, or even 60°. A resting house for Mexican orchids would also suit them in winter, if they were kept near where the air is admitted; but they will not keep healthy for many years if they are wintered either in a good greenhouse, or the cool end of a stove. In July, 1849, I flowered *C. obliquus* very fine; the flower-scape was thirty-five inches long, and stout enough at the bottom to make a walking-stick. I got it to cross, and to bear seeds by the pollen of *Valotta purpurea*; the seedlings are old enough now to show the cross to be beyond a doubt, and yet there are not two other bulbs in the world whose flowers are so much unlike each other. I have also obtained a true cross from one of the great Candlabra plants of the Cape (*Brunsvigia grandiflora*), by the pollen of *Valotta*, and others have done the like between *Brunsvigias* and *Belladonnas*; so that all these should now be placed, in a consecutive arrangement, immediately after *Amaryllis*. In Australia they can seed the *Cyrtanthus* freely enough, but they cannot get the seeds to vegetate, and I promised to tell why under *Brunsvigia*, for I learned the why by sad experience.

The seed-pod never changes colour, nor will it open until long after all the seeds are ripe, and as soon as they are ripe they will sprout immediately in the centre of the pod, and all that do so can never be got to continue their growth after being exposed to the air. I

was so fearful of some unlucky accident with my seeds, and I was sure that no one would believe me, that I effected such a cross at all, if I lost my seedlings, and being also aware of the seeds ripening before the pod gives any signs of it, I gathered the last pod in the right state, and sent it to Dr. Lindley, with an earnest request that the seedlings should be reared in the garden of the Horticultural Society. In a few days after this I was very much amused indeed at finding that the officers of the Society thought I was quite daft. They sent me a polite letter, thanking me for a green pod not half ripe enough; but they qualified this in the *Journal* (1850, page 136), and said they had a dozen of seedlings, ripe or not ripe.

D. BEATON.

COVERING COLD PITS.

Frost and snow have come at length, in unison with the prophetic warnings of the meteorologists; and, as if to rebuke the grumbling unbelievers who already began to dream about a scorching summer, without a bit of ice to cool either eatables or drinkables. It is no small pleasure to ourselves, scant as we are just now in time and covering material, to find that such a severe frost has not come until a mantle of snow was spread over the tender vegetation: and has snugly wrapped up our cold pits in the very best and cheapest protection we could give them. Only a short time ago, on the principle of fore-warning, I gave, as I conceived, as many of the minutiae of management in such unheated structures as I could cram into the allotted space; and yet I find that friends, in the same vicinity, will read these statements so differently, as to have an argument which of their respective systems is the very best; Mr. Economy allowing his pits and frames, in such cold weather, to remain without light and air for the best part of a week; while Mr. Thrifty-spare-no-labour has everything uncovered for several hours to admit all the light possible. Both have plants in cold pits; both have a few plants standing in a pit, on dry ashes, with enough of hot sweet dung underneath to stimulate them into growth; both have a few cuttings in a slight hotbed, and both have the prized luxury of a radish-bed coming on; and if I will not minutely discriminate which, in the main is correct, it is hoped that I will state what would be my own practice under such circumstances; and this I will shortly do, hoping it may meet such "difficult" cases. Then

1st. All such half-hardy plants as are generally kept in cold pits may safely be covered up in severe, dull, stormy weather, for a week or two, or longer, provided the plants have been kept stubby by plenty of light and air in open weather; that the soil and pit are dryish rather than otherwise; and though last, not least important, the inside temperature is so low, from 34° to 40°, that growth will not take place. I have just now had such a pit covered for a week; I have frequently had them covered, in such circumstances, for three weeks and a month, and the plants suffered nothing. The greenness of a pasture, when it has been for weeks covered with snow, when the frost and snow have gradually gone, would give a hint of the same fact. In thus acting, I am not at all insensible to the beneficial influence of light; but often the frost at night is attended with snow, sleet, or even dull black frost during the day; and in such cases all the light obtainable would not be worth the labour and the additional risk, and therefore I would not uncover. Again, this very day the sun has been shining beautifully after a keen frost last night; but I have not touched the covering; not merely because I was busy at the icehouse, but because I knew the plants were all right within—because there was every appearance of a night of frost still more severe than the last,

and because, above my straw covers there was a layer of snow, which, so long as it was dry, scarcely any frost would penetrate, and which I must either wholly or partially remove in uncovering. How short or how long the covers will remain, will, therefore, depend upon circumstances; but if a very bright day should soon come, and it still should be frosty at night, it would be advisable to give light; and the sun-heat would permit of the sashes being tilted at the back, at least, to change and dry the enclosed atmosphere. By shutting up early, heat is enclosed, and thus less covering is necessary. Of course, in warm weather, however dull, no covering will be required. Two precautions here are of importance: first, when long shut up, exposure to a bright sun must not take place at once; especially if the plants are near the glass, a slight shading should be given. Secondly, if frost by any means penetrate, allow the plants to thaw before you remove the covering; at least, a considerable portion should be left until then.

2ndly. Plants, that from want of air, or very dull warm weather, or both combined, have got rather weakly in their growth, will not exist in a healthy state so long when deprived of light—at any rate, even more care will be necessary, to see that the heat inside is not sufficient to excite them into growth. Taking the chance either of a mild or sunny day to uncover, even when the nights are very cold, would be to them more indispensable.

3rdly. All plants exposed to an artificial stimulus by heat will always suffer when long-confined from light, and just in proportion to the extra temperature supplied. Not many days—hardly two days—should ever elapse without the plants being partially or wholly uncovered. All pits or frames supplied with fermenting matter yield moisture as well as heat. When the weather is so cold during the day that it would be unsafe to uncover, tilting the glass for a few hours behind, even for an-eighth, or the quarter-of-an-inch, would allow any heated steam to escape. To our friends who wish to forward a few plants or cuttings by using judiciously a slight hotbed, I would say, do not begin too early, say the end of February or later, when the sun is generally so powerful and his rays so frequent as to remove all difficulties of this nature. I once lost some nice plants in a slight hotbed frame in January; they damped and rotted at the collar; the weather was such that I could not uncover them for more than a week. Neighbour plants, intended for succession, in a cold pit were safe. Whatever is growing, therefore, must have light. The tenderer the cuttings, for instance, and the greater the heat applied, the more will they be injured by complete darkness during the day. A radish-bed, getting fit to pull, and that had lost the artificial heat applied, might, in bad weather, be covered up several days without injury; but a young bed, with a nice heat below them, could not be so used. Messrs. Robson and Errington would tell us, that such covering-up during the day would soon ruin the best early cucumbers. An old cucumber grower once, not very charitably, allowed some young beginners to get into a devious course. They visited him on a regular “*Murphy*” day. It was cold enough to furnish an excuse even for gardeners donning gloves, and warm ones, too. The old man was scarce of heating material, and, rather than let his fine plants get starved, he just kept the covering on them. The edge of a light was just moved for a peep—“How nice! what, keep them covered?” said they, “Oh yes!” said he; and knowingly they nudged each other’s elbows, thinking they had got a *wrinkle*, and would soon have nice cucumbers. Need I say what was the result of their new-fashioned system? The whole theory of, and the best modes of using, protecting material have been more than once referred to.

WOOD-LICE.

“I have got a bed ready, or nearly so, for cuttings, consisting of dung and leaves, quite sweet, surmounted by a layer of rough ashes; but, last year, I lost many cuttings by *woodlice*, and, even now, I see they are in my bed. What can I do with them?” Your bed is just the thing for propagating; but it is also just the thing to encourage woodlice. Dung alone is not such a good harbour as dung and leaves mixed. Most old gardens swarm with them. I have never been able to eradicate them. I will tell you how I have kept them down. Before making the bed, wash all the walls and woodwork with boiling water. Get a few toads, and place them in the bed, providing them with a saucer and water. If you use no glasses, and the cuttings are small and tender, the toads may hurt some of them by sprawling over them. Sink a few bell-glasses, or tumblers in the bed, and bait them with sliced turnip, or boiled potato, and a few tender green leaves, and when a respectable number are congregated, turn them into a pail of warm water. Put similar baits into small pots, covered with dry hay or moss, and lay them down on the bed, and examine and empty every morning. Put, in an afternoon, a layer of dry hay, front and back of the pit; have a small pot, with fine rose, and boiling water ready in the morning; turn up the hay with one hand, and wield the rose of the pot on the rascals with the other. Besides each, or all of these, paint the rim of the pot with a mixture of tar and oil, or set it so as it may be surrounded by water, in the case of very scarce and particular articles. I have had the whole of these means in operation at once. Toads, of course, are useful; but what would a few do among such myriads of woodlice as often collect and breed in such a bed.

DEWING CUTTINGS AND YOUNG PLANTS.

This is sometimes called “*dusting*” them with water. “What is meant by this; is it watering them well overhead with a rose watering-pot? Would not this, in the case of Heaths, for instance, especially if the bell-glass was put on immediately afterwards and not moved until they began to grow, cause them to damp?” To the latter question, we say, “very likely.” To the first we say, that is not what we mean by *dewing*, nor at all in unison with the explanation given of these new terms. The questions are, no doubt, suggested by the article, pages 322 and 323. I would just remark, in passing, that though the initiated may strike many things without moving the bell-glass, the inexperienced had better not try it, but confine themselves to the rules for general and particular propagation copiously given; and that the *dewing* there spoken of had reference, as will be seen from the context, to half-hardy plants chiefly, and not Heaths, as these formed no primary matter of enquiry, such as the article was designed to meet. Even Heaths, as well as other hardwooded cuttings, may often be *dewed* with advantage, however, if, as has been well inculcated, a little air should be given at night; or after they are callusing and rooting, it is desirable, for consolidating growth, to give more air and light than they would otherwise stand without shading; taking care, however, that the foliage was dry before the glasses were put down tight. In fact, in such circumstances, we often leave glasses off at night, and put them on during the day; and when a little farther advanced, but not sufficiently so to stand a bright sun unhelped, we prefer very often such damping of the foliage, instead of shading, or pulling glasses on, and thus force the leaves to absorb, as well as perspire. Now, we will dew or dust whole beds of cuttings several times in a day, keeping them thus in a moist atmosphere, and yet even the surface soil will never get soaked, nor even, we may say, wet, because the water is

given to the foliage more like a mist than anything else, there being no necessity for a drop of water to be seen bigger than the smallest pin-head, or even pin-point if you like. "Then how is this done? I never could get a rose watering-pot fine enough to do it; besides, there is the finicking, time, and the nasty drip which will fall where you do not want it." Read's common garden syringe is my favourite instrument; it is so simple, so effectual. With every syringe sent out there are three nozzles—two with holes pierced to resemble a rose of a pot, and one with two projections, one of which is the suction medium more particularly, and the other the delivering jet. This last nozzle is my favourite; in fact, the others are generally put aside as pretty things to look at.

A very forcible stream of water can be delivered with this jet; but by placing your finger on the point of the jet, just according to the pressure you give to the descending piston, will you be enabled to give out a misty vapour and water in every degree of fineness and quantity, from that *dewing* up to the full volume and force of the unopposed jet. Now do not try such a plan with tender cuttings at first. You must practice a little on anything, or even upon nothing, until you acquire a tact, and then you will look on all other nozzles of syringes as cumbersome and useless. I once had a young man that never could do it. It was a regular annoyance to *he*. He was the only one that did not like it as well as myself. When, with constant wear, the thread of the jet is worn out, the finger is placed over the hole left in the same way; nay, some of my men actually dismantle them thus from choice. A little practice, without any deep study of physical forces, will enable you to send this dusting, or *dewing* with water, in any direction you think proper. To those who have never tried it I should be afraid to state the *short time*, and the small quantity of water with which twenty frame lights of cuttings may be thus *dewed*, every leaf damped, and yet the surface soil scarcely moistened. For all bedding plants, propagated either in autumn or spring, after being once watered, I prefer this *dewing* to watering much, or to shading, unless in extreme cases. A distance from the glass, and this *dewing* in sunshine, prevent perspiring, without debilitating as shading does.

R. FISH.

CONIFERÆ.

(Continued from page 366.)

1ST—SECTION OF PINUS, WITH LEAVES TWO IN A SHEATH— (CONTINUED.)

PINUS RESINOSA (Resinous Pine).—This is the Red Pine of Canada and Nova Scotia, growing to the height only of thirty feet; but, as its name imports, yields an immense amount of resin, and being a native of such cold climates, is suitable to plant in the coldest parts of this country.

PINUS SYLVESTRIS (Forest, or Scotch Fir).—A well-known tree, and a very important one. I might fill the whole of this paper by describing its useful properties, but they are so well known it would be a waste of the reader's time. A few remarks on its culture will, however, be useful. It will grow in almost any soil or situation. On the tops of high mountains, and on poor soils, it becomes stunted and blown sideways by the winds; whilst in low, sheltered places it grows rapidly, but as quickly decays, and in such situations the timber is almost useless though, even when decayed it is excellent for fuel. The proper situation to plant it in, where it will form fine trees with sound good timber, is where the elevation is intermediate between the high mountain and the lowland valley, upon a rather clayey

subsoil, with a surface of loamy peat or gravel. In the Great Park at Windsor, on the road-side leading to Bagshot, I observed, very lately, some beautiful specimens. The wood there has been judiciously planted and properly thinned, and the Scotch Firs exhibit most clearly the effects of good management. Several of them were, and in fact are, remarkably handsome, even as objects of ornament, being perfectly straight, and clothed with luxuriant branches down to the ground. Let those who despise the Scotch Fir on account of its being so common just take a ride out that way. I am sure they would be as delighted as I was. The dark green foliage and reddish bark render them exceedingly interesting.

There is no family in the whole tribe of Coniferæ that has so many varieties as the Scotch Fir. These varieties are desirable as objects for the Pinetum; I shall briefly enumerate them.

P. S. Altaica, from the Altaic mountains.

— *argentea*, the Silver-leaved, very beautiful.

— *Erzeroum*, from Persia, with broad leaves.

— *Genevensis*, from the mountain near Geneva.

— *glauca*, the Milky-green-leaved.

— *Haguenensis*, the Pin de Hagenau, from the south of Germany.

— *monophylla*, the One-leaved, a curious variety, with one leaf in a sheath.

— *nana*, the Dwarf.

— *pendula*, the Weeping.

— *pygmaea*, the Pigmy.

— *pyramidalis*, the Pyramidal.

— *Rigensis*, Pin de Riga, from Russia.

— *tortuosa*, the Twisted-leaved; so named by D. Don, of Forfar.

— *uncinata*, the Hooked-coned; so named by the same author.

— *variegata*, the Variegated-leaved.

2ND—SECTION OF PINUS, WITH LEAVES THREE IN A SHEATH.

PINUS AUSTRALIS *syn.* *P. PALUSTRIS* (Southern, or Marsh Pine).—A very important species, furnishing the red deal of commerce. It is almost the best of all the North American Pines, the wood being fine-grained, capable of a high polish, and of durable quality. The appearance of the tree is very beautiful; the leaves are very long, and of a bright green, and it attains the height, on an average, of seventy feet. It will thrive well near the sea, on a thin soil, and in such a situation is perfectly hardy. More inland it is rather tender, especially in the north. The variety from the north-west coast of the same country has proved to be much more hardy.

PINUS BENTHAMIANA (Mr. Bentham's Pine).—So named by its discoverer, Mr. Hartweg, in honour of G. Bentham, Esq., late Secretary to the London Horticultural Society. This is one of the gigantic firs of California, growing there to the amazing height of 200 feet, with a stem nearly thirty feet round. What a mass of timber there must be in such a noble denizen of the forest! California is rich in gold, the root of all evil, but it is richer in its noble trees, which are equal in magnitude to the finest forests of Brazil. Mr. Hartweg found this noble tree growing on the mountains of Santa Cruz, at a considerable elevation above the sea. Whole masses of it were growing together with *P. Sabiniana* and *P. Lambertiana* slightly intermixed, and as both these are known to be perfectly hardy, it may be reasonably supposed that *P. Benthamiana* is hardy also. It is, as yet, very scarce, though there is a fine specimen or two in the gardens at Chiswick. When more plentiful, and its hardihood fully proved, it should be planted largely for its valuable timber, as well as specimens for ornamenting the Pinetum.

PINUS CANARIENSIS (Canary Island Pine).—This Euro-

pean species is found growing on the mountains of the Canary Islands, in the clefts of rugged mountains, where it grows to a great size in circumference, though not in height, seldom exceeding, in that particular, more than seventy feet. In Devonshire and Cornwall it lives in the open air with impunity, but more northerly should either be protected or grown in a lofty conservatory.

PINUS GERARDIANA (Gerard's Pine).—A low-growing tree, with shorter leaves than any species in this section; not particularly handsome, but it is the hardiest of the Nepaul species.

PINUS INSIGNIS (Remarkable Pine).—I have, in my "Jottings by the Way," frequently mentioned having seen fine specimens of this most remarkable Pine. There are also some fine trees of it in the famous Pinetum at Dropmore, the seat of Lady Grenville. So different from all other Pines is this fine species, that it may be known at a considerable distance. It grows very dense, and the foliage is of a bright green. No collection, however small, can be complete without at least one specimen. Too much in its praise cannot be said or written, and as the wood is said to be excellent, it ought to be extensively planted, which, no doubt, it will be when the price is lower. Native of California, where it attains the height of 100 feet.

PINUS LLAVEANA (La Llave's Pine).—In the grounds at Delapre Abbey, near Northampton, there is a fine tree of this handsome species. The cones are nearly without scales, a remarkable distinction, and the seeds are used as food. The branches are slender and spreading, and are thickly clothed with foliage, which give out a pleasant perfume. Though a native of Mexico it is perfectly hardy.

T. APPLEBY.

(To be continued.)

THE PELARGONIUM.

(Continued from page 384.)

PROPAGATION: BY CUTTINGS.—The grand secret in success of propagation by cuttings consists in having the wood or shoots in right condition. It should neither be too young nor too old; very young shoots quickly damp off, and old ones are slow and not sure in making roots. Short stubby shoots make the best cuttings, and the point where the bottom of the cutting should be made should be in a half-ripened state. I remember, when I first had the ambition to try my skill in propagation, reading, in *Cushing's Exotic Gardener*, how to strike cuttings of Pelargoniums. He directs them to be put in pure loam, and gives the sensible reason for it that pure loam contains the least amount of putrescent matter. I put his recommendation into practice with considerable success; perhaps nearly, if not quite equal to the success that would attend me now with all my, as I suppose, superior experience. Propagators use now another article to plant cuttings in which most certainly contains still less of any decaying matter that would cause cuttings to rot than even pure loam, and that is pure silver sand. To be more certain of success, the following articles are necessary:—clean cutting pots (the size named in the pottery large 48's) which are five-inches-and-a-half in diameter, inside measure; clean drainage, formed with broken potsherds; pure loam, sifted through a coarse sieve; and the pure silver sand.

Then the place to put them in—either a good propagating house, under a small frame covered with glass, and set upon a heated surface of charcoal or coal ashes;—or a frame set up on a gentle hotbed made of well-tempered stable litter and leaves, and six inches thick with sawdust or coal ashes. With these conveniences, and a due attention to choosing cuttings in a proper state, with a constant supervision in shading,

giving air, and potting off as soon as roots are formed, there is no doubt of success—almost every cutting will grow.

The best time for the operation is the month of March or April, though cuttings will strike well through all the summer months. Nurserymen, who propagate this class of plants on a large scale, put in cuttings most largely when the plants are cut down after the season for flowering is over; but such late-put-in cuttings do not make such fine plants the following year as those that are struck in early spring. For the amateur, who only desires two or three plants of a kind, the first season is by far the best; and it must be a poor plant indeed from which that number of plants cannot be taken then.

Having fixed upon the time, go over the plants and take off as many cuttings as will fill one pot, choosing them as described above. With a very sharp knife cut the bottom of each cutting right across, close to a joint: this is called an horizontal cut, and should be made, if possible, just at the point where the old wood terminates and the new begins, and then cut off the bottom leaves, leaving two or three to each cutting. Place a mark, either a number, or the name, to each variety, as soon as all the cuttings of that variety are made, and so proceed till all that are taken off are made and marked. Let them lay on the bench till the pot is prepared to receive them. This short time will do them good, by drying up the wounds made with the knife.

Then take the pot, and put a large piece of potsherd over the hole, propping it up on one side with a very small bit of the same material. This is to allow the superabundant water to escape freely and readily. Over this potsherd place fully two inches of smaller broken potsherds, and upon them put a thin layer of the turfy sifting out of the loam. Then fill the pot to within an inch of the top, with the sifted loam, and that remaining inch with the pure white sand, give a gentle watering, and let it stand till the water settles, and the sand is firm. With a small smooth stick insert the cuttings round the edge of the pot, pressing the sand firmly to the bottom of each. Take care to place the mark to each variety as they are put in. The stick will leave a little hollow to each cutting, these hollows should be filled up with some dry sand; when this is done, give a gentle watering again, and the operation is complete for that pot. Proceed so till all the cuttings intended to be put in are completed, then place them in the propagating-house or frame on a hotbed.

The attention they require after this, is to shade them from bright sun, and give a little air occasionally to let out the damp steam, but do not shade them too long, but accustom them to bear the sun by degrees. As they form a callosity (a swelling at the base of each cutting), they will soon bear the full light, and will then emit plenty of roots. To ascertain this, take up a pot and turn it upside down, and give it a gentle stroke, holding one hand ready to catch the ball. If they are rooted, the white tender roots will be seen running down outside the ball, between it and the pot. Should that be so, pot them immediately into small pots in a more generous soil, consisting of loam and leaf mould in equal parts, with a free admixture of sand. Replace them in the frame for a week or ten days, giving them tepid water once or twice as they need it. Then gradually inure them to bear the full sun and air, and place them on the shelves of the greenhouse near to the glass. After that treat them as the rest of the older plants.

Some of the fancy varieties are very difficult to strike by cuttings in the ordinary way. The cuttings of these should be planted in shallow pans filled with sand entirely, the bottom of each cutting touching the bottom of the pan. These should be placed on a shelf

near the glass of a good greenhouse, and by this method the most difficult may be propagated.

For very free growers a more simple and summary method may be adopted, but it must be put into practice during the summer months. Choose a shady border, take away the common soil and place in its stead three or four inches of good loam mixed with sand. Make the cuttings in the same way as is described above, and plant them in rows across this prepared border. Water them, and leave them to their fate. The greater part of them will strike root, and before the frost arrives, take them up carefully, and pot them, and remove them into a cold-frame till fresh roots are formed, then place them in the greenhouse among the rest, and give the same treatment. One point must not be neglected, and that is to nip off the top of each cutting as soon as it is potted off, to cause the side buds to break, and thus form nice low bushy plants.

T. APPLEBY.

(To be continued.)

THE ONION.

FROM time immemorial it has been the common practice of the cottager to sow his Onions as early in the season as the nature of the ground and his other duties would permit. Against this rule nothing can be said; necessity occasions many delays which cannot in every case be overcome; but there are many instances where a little perseverance might accomplish what an ordinary observer would regard as impossible, and of this class of duties is that of putting forth all the latent energies to the forwarding of work which a busy spring is sure to bring with it. On that score, therefore, we urge on our cottage friends who have much garden work to do, to be at it betimes; what is done now need not be done again, in many instances; while much that is neglected now can never be replaced. Witness the sad condition of ground which has never been tilled the whole winter, and probably may be lying idle, without deriving the benefit which the little winter we are likely to have may impart to it. It is not in every case that such neglect is the result of sheer necessity; a little determination would often put the affair on a different footing. Now the object of the present chapter is not so much to urge the necessity of endeavouring to make up for the delay which the elements have subjected all of us more or less to, but to make some observations on the sowing of one of the most important crops on ground which we will suppose to have been prepared for it in the best way the season would allow.

There are few vegetables can vie with the Onion for its antiquity and wide-spread popularity, and it has been made to accommodate itself to a much greater diversity of clime than many others; yet it must be admitted, that countries ranging within the "temperate" zone are its favourite habitat; and its culture has certainly attained a degree of perfection in those countries washed by the Mediterranean which we in vain look for elsewhere; and, as may be supposed, its importance there is duly valued. With us, the southern parts of the kingdom certainly exceed the northern for bringing this production forward; and though we often enough see a bad crop even south of the Thames, yet the chances there are much more favourable than those north of the Tweed, other things being the same; so that we are constrained to the belief that a much greater amount of heat and light is necessary for the perfection of this vegetable than for many others; although varieties suitable for a cold climate have been raised.

Onion seed will not ripen well in the "far north," and the importation of that from a more southern district is attended with a sacrifice. The plant may, therefore, be called an exotic, since it cannot reproduce itself

in the way ordained by nature. Now, though we expect to see the Onion grown more extensively than it has hitherto been, and used, too, with more freedom than heretofore, we should also like to see some hybrid varieties, possessing all the merits of those we have, with the additional one of resisting the cold ungenial climate of the north, so that we may be able to grow a crop with as much certainty of success in the parallel of the 58th degree of north latitude as in the 50th. This, however, is not likely to be accomplished if the present system of importing seed from Paris, and elsewhere, be continued, because the constitutional character of the plant cannot possibly undergo any change while the important process of "seed saving" is still confined to a climate so much more genial than the one in which it is sown. This, of course, must be the work of time, and no one can be sanguine enough to expect the seed-ripening process to travel northward with railway speed. How many generations have passed away since its cultivation was first directed to that quarter, from the temperate regions of Africa and southern Europe, where it is presumed it was first found indigenous; but the science of the present day being more guided by correct principles, may effect a change in much shorter time than was accomplished by our forefathers in their hap-hazard course.

But to return to the Onion, whose progress seems less difficult to determine—we may say, that its capabilities of bearing cold seems to have undergone a gradual increase, so that it is now grown at a higher northern latitude than it used formerly to be; and we have no doubt but it will, with judicious seed saving, &c., be enabled to bear still more cold, as its culture becomes better understood. This theory is, I know, opposed to that which points out the Potato as being killed by the first frost now, the same as in the days of Raleigh, who introduced it; but we are not to reason from that cause that the habit of the plant has not undergone a change; for most assuredly it has, otherwise it would not be in a condition to furnish such fine crops of useful good tubers, as it often does (even now, in spite of disease) in the dampest and most unfavourable districts of the kingdom; and certainly Potatoes may be cultivated to advantage in localities where but a meagre crop of Onions is expected; but that the latter may be improved by carefully selecting seed from bulbs grown and perfected (for we cannot expect a good produce unless this be attended to) in a climate as near approaching to that in which the crop is sown as possible, is both likely and reasonable; we, therefore, strongly advise the amateur residing in some unfavourable locality in the "far North," to procure his seed from some one who can warrant it as having been grown as near his own neighbourhood as possible. It is likely that he will have to pay a little more for it on that account, but this will be repaid him in the superior crop he will have, if other things be equally favourable; and we take this opportunity of saying that we are no advocate for "cheap seeds," in the general sense in which that term is understood. Seeds, to be genuine and good, cannot always be grown cheap; and that ruinous competition in the trade, coupled with a sort of gullability on the part of buyers, has led to various things being offered for sale, at prices lower than those they can be grown for in a legitimate way; and though Onion seed, as a whole, may be more pure than most seeds, yet it is well known the *well-keeping* of the produce depends, in a great measure, on the seed having been saved as near home as possible. Foreign seed is notorious for the bad keeping qualities of its produce. This has led many growers to grow their own seed in those favourable districts of England where it will ripen well.

We will suppose the amateur to have procured "good

seed," and that his ground, which had been manured and ridged in autumn, had been levelled down early in February, and has undergone the changes of weather during that month; it will be fit to receive the seed towards the end of it, or beginning of March, provided it be sufficiently dry to allow treading upon without kneading it into an impenetrable mass; this, of course, must not be done under any circumstances, for when the weather seems unlikely to allow the ground to be trampled over without consolidating the mass into that state, it must not be trod upon at all; but the plot, instead of being sown in continuous rows, must be divided into beds of about three-feet-and-a-half each, with eighteen-inch alleys, and the crop then sown broadcast. This plan, however, need not be adopted when access to the ground can be had without injury; for we prefer sowing in rows about a foot apart, as the crop is easier and better managed during the summer, and the produce for a given space of ground is generally larger. Shallow drills drawn by a hoe is best, which cover up when sown; and do not be too particular and exact in the raking, provided the seed be only covered, as that is the principal thing. The smooth nicety with which the ground is sometimes dressed is detrimental to the crop. The rains, &c., which often intervene before the young plants make their appearance, flatten the surface so much, that it presents a very unkind medium for them to vegetate in, while it cannot be stirred until the plants show themselves. When the ground is very stiff, and likely to form a hardened surface, impermeable to the atmosphere, &c., it is better to mix something with it to keep it open. It has for many years been the practice of those residing in districts where much charcoal is made, to mix a part of the "ashes or refuse" with the soil the onions are sown in, more especially the top part. This important addition prevents ground, however tenacious, from caking into a solid mass. It has other good properties as well, so that when it can be obtained, it may be used with the best possible effect. Coal ashes are not so good, but they are still useful; still more so, however, are wood-ashes; and, in fact, any light opening substance that will prevent the ground running into that hard, impenetrable mass, which a stiff soil is prone to do when soddening rains are followed by dry weather.

Of the kinds proper to sow it is almost needless to say much. The *Strasburgh* is, undoubtedly, one of the best keeping kinds; but the bulbs are uniformly less than the *Globe*, *Spanish*, and some other kinds. The *James Keeping* is also a good onion, and keeps well; and, to those who are not particular to keep each kind by itself, we would advise the *Strasburgh*, *James Keeping*, and *Reading*, to be sown together mixed, and the other kinds mixed also, and sown in the mixed state. This mixing we prefer in cases where bought or doubtful seeds are used, because the chances are that one of the kinds may be worthless, or nearly so; consequently, a blank is made on the place where it is sown. This is, in a measure, obviated by mixing the kinds, and sowing middling thick; it is easy to draw a few when wanted, while it is not always that planted-out ones succeed well in any but favourite localities.

As a general rule, Onions like a deep, rich soil; but, with judicious management, good crops are often seen on very indifferent ones; but then artificial assistance has been allowed them, and probably the season has been propitious. But, as they uniformly form an important crop in every garden, from that of the humblest cottager, upwards, it behoves the amateur to grant them that due allowance of the "good things" most crops delight in, in order that his crop may be equal with, if not superior to, the poor cottager who may be neighbour to him.

Much more may be said on this matter; but, as our space is occupied, we must for the present take leave of

our young friends, and advise them, while planning out what crops they think most suitable and profitable for each division of their garden, to bear in mind, that this deserves one of the best places; and, if the instructions here given be carried out, and the season be at all favourable, the chances are that a good crop will be the issue.

J. ROBSON.

FEATHERS.

A LIGHT title is this, yet bearing fast and fresh to us reflections many and weighty; though we should hesitate before we quite agreed with Mr. Macgillivray, in "more admiring the mind that had discovered the causes, relations, connections, and objects of a feather, than that which had measured the magnitudes of the planets, traced their orbits, and calculated their velocities."

Wondrous as is the structure, calculated to unite the greatest strength with the most extreme lightness; extraordinary as is the chemical composition, coagulated albumen, which is most powerful to resist breakage, and, unlike the gelatine of hair, is insoluble in water; curious as is the arrangement of every portion of the feather—and varying in every genus of birds—whether we examine the *tube* or *barrel*, the *shaft* or *stem*, or the *vane*; and beauteous as are their tints—yet we must not, for our present purpose, descant upon any one of those peculiarities, but must confine our attention to the markings which characterise the feathers of the various varieties of our Domestic Fowls.

On this subject some difference of opinion, and much doubt, in the minds of amateurs, exists. After mature consideration, and after listening to many arguments, we have resolved to publish a series of drawings of the most perfect specimens we can obtain; and our readers will oblige us by sending us any that they consider very superior.



PENCILLED FEATHERS.

The term "*pencilled*" is strictly applicable only to the gold and silver varieties of the *Hamburgh Fowl*. For, although the hybrid races of a farm-yard, where *Hamburgh* blood has been at some time infused, often exhibit traces of this plumage, more or less distinct, according to their degrees of illegitimacy, yet, a well-bred, perfect specimen should have nearly every feather on her body (for this characteristic is almost limited to the female bird), the neck hackle alone excepted, distinctly marked with, at least, four parallel transverse dark bars, about one-sixth-of-an-inch in width. It is this peculiar marking that constitutes the *pencilled* feather; the ground-colour of which will be either a rich, but clear, yellow, or French-white, as the birds may respectively belong to the gold or silver varieties.

"I HAVE NO ONE TO TAKE CARE OF ME."

By the Authoress of "My Flowers," &c.

AT the risk of being thought prosy and wearisome, I am going to speak again on the subject of thoughtless, ungodly marriages. Next to the choice of "whom ye will serve," comes that of whom ye will marry; and awful indeed it is to see the whys and the wherefores of these joinings together. It is a subject that can scarcely be too strongly enforced, or too roughly handled; for not only does it affect individual happiness, but it is injurious to the characters and minds of the children that spring up in the midst of misery, and discord, and sin; and it has powerful influence, too, upon the good of society at large. Even among the humble classes, what a perfume proceeds from a happy, well-ordered, religious family, where the parents are united in heart and faith, as well as in matrimony; where the daily labour is sanctified, and the hours of rest are blessed; where the Sabbath is called "a delight, honourable," and the evenings pass peacefully in each other's company—far from the beer-house and the "way of sinners," and close with prayer and praise! I believe that people of decided piety are but too apt to be weak in this momentous matter. Perhaps no other temptation on earth could move them *but this*. How needful, then, is close and anxious walking with God, that when such snares lie in our path we may be enabled to step over them; for the arm of the Lord only can do this.

Jane Ford was a widow, with two sons. She was a superior person for her rank in life—mild, and gentle, and pleasing in her manners, very trustworthy, and clever in her business. She lived in the family of a rich farmer, was greatly regarded by the family, and was a sort of cook and manager together. Any one would have thought that this was a comfortable place for a person in her situation; that she was settled there by the good Providence of God, and that if she dared to trust in his promise to the widow, all would go well with her. One might reasonably have thought this. But a snare fell in her way—one so plain and easy to be understood, that it was wonderful she should have put her neck into the noose. "Surely in vain is the net spread in the sight of any bird."

John Sims was a notoriously drunken carpenter. He was a good workman, but there was no other good in him. He was a by-word in the village; his very name made people shut their doors, and his face declared that report did him no wrong. It was a matter of wonder and admiration to the whole parish, that in the time of the riots John Sims was the only man who did not join the mob. People spoke to one another about it: "Think of John Sims, he not being in the mob! how came he not to be there, and the head and front of them all." But so it was.

Some years after that memorable time Sims became a married man. He chose a very clean, respectable wife, but she very soon faded and died. Every one wondered at her marriage, but no one was surprised at her death. Sims went hammering on one minute, and "drinking himself drunk" the next; so that no reasonable expectation could be entertained of his making a woman happy, or of her living long upon the earth.

John Sims remained for a time in singleness of estate, but at length he took it into his head to fancy Jane Ford, and he advanced accordingly. In the face of all bygone facts, Jane did not *at once* dismiss him. She put before him his habit of drinking, and his general character; but he promised to give up his beer for her sake, and took to go to church. This was a convincing proof, *to her*, that he loved her, and would make her happy; and so she became his wife. Every one lamented the folly and madness of this step; there was no one who could give her a cheering word; she left a respectable and comfortable situation to shut herself up in a dark, dismal cottage with John Sims! The only excuse she attempted to offer was, "I have no one to take care of me."

It was not long before Jane Sims awoke to the full consciousness of what she had done when she gave up God's promise for that of man. Her cheerful smile and untroubled countenance were gone. She was not like the same person. It was impossible not to see that her married life was a bitter one; the tearful eyes, and melancholy face,

spoke the truth too plainly. Sims gave up going to church very soon after his second marriage; his red, swelled, ill-looking face was again seen, day after day, in the beer-house; and he went staggering home at night, just as he had done before he promised to leave off drink.

Let woman lay this to her heart: if a man will not "turn from the wickedness that he hath committed, and do that which is lawful and right," for the sake of a crucified Saviour, he will never do it for the sake of a wife. On a sick-bed we promise in our terror to lead a new life, if the Lord will once more raise us up; but what a promise is this! It is like the morning cloud, and the early dew! When we rise up we forget our fear; and we go forth again to the mire. Just like this is the promise of a man who has a worldly point to gain—a wife! When he has won her, and seated her by the fireside, he too, will go forth again to the mire, and leave her to bewail her folly. No change *can* take place in an unrenewed heart. Unless we are "born again," we *cannot* do the thing that is "lawful and right." Let us all remember this.

The violence and madness of John Sims, when he is under the influence of drink, is fearful. He enters his cottage like a roaring lion. His wife trembles and weeps, but she dares not "upset" him; nor, indeed, should a wife at any time do so. Her two boys see the condition of their mother's husband; they see her degraded situation; they hear his oaths and violence; but they can do nothing. Oh! what an example for the sons whom God has given her! What a bitterness, to feel that she has set it before their eyes; that her own folly has done this! "I have no one to take care of me," must rise up like an adder in her path *now*.

Sims drinks sometimes for two days together; and when he has come to his senses he goes off to work with his step-son behind him. One sabbath morning we met him in his dirty dress, with such a face of woeful intoxication, that it made us shudder. He had been drinking, "off and on," for nearly the week before, and had strolled out, he hardly knew where, to cool his burning head.

Poor Jane goes out very often to cook and assist in a neighbouring family. She is obliged to get her own bread, for she has but little of her husband's. She is not often, therefore, in her own home; and when she is, it is in fear and trembling. She speaks with great meekness and submission of the trials she has to bear. She went out to seek it, and must now support it as best she may. She lays religious books in her husband's way, and talks to him in his sober minutes. He will read and hear; but he lives next door to a beer-house, and he rises up from the Bible and the tract, to go to the haunt where Satan loves to dwell.

"I have no one to take care of me." This may be the feeling of many a single woman. Let her beware! Let her remember the care that John Sims takes of his miserable wife! Let her remember the home which poor Jane escapes from as often as she can! Let her remember that the "arm of flesh" is a broken staff to lean on, and will surely run into our hand. Let her remember that there is a God "of the fatherless and of the widow," who is the only One to *take care of us*, the only One on whom to cast our burden, and to look confidently for protection and care. Do not let us deceive ourselves in this matter; we are quite ready to shut our eyes, and stupify our senses, but we do it with a curse and not a blessing. Even if we choose a worthy object, what kind of a reason is it to give, that we want to be *taken care of*? Let me solemnly and earnestly repeat to *all* my readers, male and female, high and low, for it concerns *us all*, the awful words of the Lord God of Hosts himself: "Cursed is he that putteth his trust in man, and *taketh man for his defence*, and in his heart goeth from the Lord." When we marry to be *taken care of*, we do depart from the Lord.

ALLOTMENT FARMING—MARCH.

ONE of the greatest faults in allotment or cottage gardening is the injudicious way in which mixed cropping is carried out. This arises principally from ignorance in the cultivator of the importance of light to the vegetable world. How often have I received for an answer, when urging the impropriety of certain combinations on the score of impeded light, "Oh, they will get light enough."

Now, light is a relative affair, not to be taken abstractedly with regard to cropping, for many of our vegetables do not arrive at that perfection they attain in some other climes where the light is by far more intense. So, then, it is not a question of sunshine alone, but of that free exposure on an all sides which may receive the greatest number of rays.

Again, a given crop may be at one period benefited by a certain amount of shade, or rather partial deprivation of light, yet the same crop, at another period, requiring all possible sunlight. Although this question is closely bound up with that of the circulation of the air, yet the two principles are, in their individual character and effects, different. For instance: a cucumber bed, exposed out-of-doors, will receive abundance of air, or, in other words, a free circulation with the light; but those confined in a hotbed cannot be said to do so. Or, to come to a case more familiar—suppose a few rows of potatoes between two parallel rows of tall peas, can it be said that these potatoes enjoy as free a circulation of air as those on the brow of an open field?

We will now enquire what the consequences separately are of a partial deprivation of light, and an impeded circulation of the air; hoping that such enquiry may serve to widen the cottager's views, and lay the foundation of more judicious cropping. To begin with an extreme case—surely our allotment men may have noticed blanched rhubarb, sea-kale, or celery! The consequence here is, that parts which would have been green, under ordinary circumstances, become pale, and, in addition, lose much of that intensity of flavour or strong taste with which nature has endowed them, a partial abstraction of which renders them more palatable as food for man. But then, it must be borne in mind that these blanched parts are, in a great degree, deprived of those natural functions which elaborate or prepare for future seasons, or future demands, made by root, branches, flowers, fruit, or seed. Now, although this blanching does not take place with our ordinary crops, under ordinary circumstances, yet precisely the same effects, modified by the degree of the evil, must assuredly follow, if the foliage of a plant is deprived of the action of a portion of its leaf surface.

And what about partial deprivation of air? This has two bad bearings: in the first, it has a continual tendency to "draw" plants, as gardeners call it; and in the second, to engender, through the rotting of decaying and light-deprived portions of the plants, corrupt influences, which sometimes act in a similar way as corrupt emanations from animal matter, in exerting a morbid influence on bodies contiguous. Our readers must have seen the evil effects of leaving over thick young seed crops long beyond the thinning period, perhaps smothered with weeds; and they may have noticed the havoc produced on them by a sudden thinning, followed by bright sunshine. We have noticed peas lying on the ground, unstaked, engender stagnant damps to that degree, in dull and wet periods, as to seriously peril, if not utterly destroy the crop. I willingly grant that the latter examples are of a compound character, less or more—a matter of light abstraction, as well as of impeded circulation of air; but it will serve as an illustration of the points in hand.

Let every small gardener, or farmer, study well these principles, for they may rest assured that society cannot, in these days of steam, remain stationary. Whatever takes place in the heart of society will soon be transmitted by the various arteries to the extremities; and as PROGRESS is the watch-word in the superior portion of society, so must it soon be with the lower.

I may here observe, that most of our root crops, such as carrots, parsnips, mangold, swedes, &c., will endure tolerably close cropping in the mixed way, if necessary, until the real "bulbing" begins—say about August—when they require all the light our climate affords on an average. This being conceded, surely our friends may so plan their cropping as to accommodate themselves without discommoding the crops.

Space will not permit me to show the various combinations of which even our most ordinary crops are capable; much must ever be left to exercise the ingenuity of the cultivator. This is as it should be. Men are not mere machines; being endowed by God with reasoning powers in material things, nothing is needed but to direct the uninformed mind as to those principles, which must ever form the groundwork of good practice; the rest but requires an

earnest and attentive mind, with a corresponding degree of exertion.

Now, let us examine the position of affairs, and descend to the dull routine of *urgent business*. I do think, that for present purposes, most of the crops may be thrown into three divisions, viz.:—Early crops, midsummer crops, and autumn or winter crops, mostly roots. I do not urge that this is the most complete division of the subject, but that under present circumstances it is the most prudential and practical. Let it be remembered in all this, that the potato, which at present obtains the preference as food for man, cannot endure shade during the whole growing period. It is all very well to talk of a plot beneath an apple-tree having escaped the blight, when those on the hill-top were infested. We talk thus when reasoning on principles; but when March arrives, the maxim must be "a word and a blow." Whatever may have been proved about potatoes in shade, my advice is, plant early on the highest and driest ground, unless in a parching district. As to manuring, the experience of our first-rate men, during the existence of the dreaded malady, is quite averse to it; at least in a fresh state. But here a question arises in the mind of those who have smart rents to pay, and many bairns gaping for food—"If my family must be fed, and I must pay my rent, I must have a full crop; can I get one without manure?" My answer is—if you do, your soil must be in a good heart from previous crops, or you will assuredly reap a very moderate produce.

BUSINESS OF THE MONTH.—Our February remarks will serve to point to the chief policy wherewith to commence the spring campaign. The unusually wet period through which the country has passed, will have taught our standstills a lesson they will not readily forget. Those who have been wise in time, will, before this, have taken at least remedial measures as to the removal of stagnated moisture. Extra drains, and water courses of a temporary character, will have been called into use; and now a further piece of advice; do not introduce any crops, if possible, unless the soil is in a mellow state. As to cropping, we will divide the month into three parts—beginning, middle, and end; but it must be understood, that many operations cannot be confined to set times; such merely serve as reminders.

BEGINNING.—Peas and Beans must be thought of. This is a good time for a full crop, and we advise the Green Imperial Pea, as furnishing a glut, and coming off the ground in good time; they, moreover, never ramble and shade other crops. In Beans, the Broad Windsor or the Long-pod. Onions must be got in now, the ground dug deep, and a little manure in the lower part of the trench. Parsnips sow directly; they are a hardy plant, and require a long season. Trench deep, and work down manure. If alone, they may be twenty inches between the rows. Cabbage plants must be immediately got out; these may be a stolen crop; many take to the mangold or swede ground, the latter sown in April between double rows of cabbage. Cauliflowers, too, planted, and the winter Lettuce plant; the latter a stolen crop, on rich soil. Onions and other store roots for seed may yet be planted. Leeks may be sown directly; also Lettuces. These may be mixed with the Onions, as likewise a few Radishes, with some Early Horn Carrots. Spinach, if required, may be sown as a stolen crop; and as for Cabbages, I say with Miss Martineau, sow a bed once a month, beginning now, and ending in the middle of August. Green Kale, Brussels Sprouts, and Savoys, may be sown; but it is necessary for the operator to see well his way, for the sowing of those things must, in the main, be regulated by the period at which the ground will be vacant. In dry weather the hoe should be run through the young Cabbages.

THE MIDDLE.—By this time the soil will be getting in mellow order, and now it will be necessary to get the plots ready (whilst dry) for Mangold, Swedes, Carrots, &c., if not previously done. It is almost needless to repeat, that there is no guarantee for a full crop without deep digging, and a liberal manuring; and I think that, as a general principle, the manure should be kept at a rather low level, using a guano mixture in the drills to set the young plant on its legs. A plan I often practice is, in digging two spades deep in yard-wide trenches to spread the manure, and then dig one full spade's depth of the manure and soil, and before

digging the second, to stir the aforesaid deeply with a fork, then to dig a very moderate "spit," and cover the other with it. The mere surface may be rather poor, and if such a compost as I have often described be kept on hand, viz., soot, guano, and very old leaf soil, or manure, all blended, it may be sown liberally with the seed in the drills, in order to push the plants.

END OF THE MONTH.—We have little fresh cropping yet, but the beginning of April will bring this business. I may here advise, that all digging be well carried out before April comes in, and that the whole plot or garden receive a thorough cleaning before *April showers arrive*. This is generally a good hoeing month, and care should be taken to use the hoe freely, raking up as the hoeing proceeds.

R. ERRINGTON.

THE APIARIAN'S CALENDAR.—MARCH.

By J. H. Payne, Esq., Author of "The Bee-Keeper's Guide," &c.

FEEDING.—Never, surely, was the necessity for feeding so imperative as at the present time, as, from the extreme mildness of the winter, the bees have been in almost constant activity, and consequently consuming a much larger portion of food than usual, and this, too, after an unusually bad honey season. I am not quite sure that the Ivy has not afforded them some little through the winter, for, certainly, they have been attracted to it almost every dry day; and breeding, I feel assured, has been going on in some of my stocks from the middle or early part of January, for on every sunny day water has been sought after by the bees with great eagerness. Now, with all this, a rapidly increasing population, a scanty store of honey, and, perhaps, a cold spring, what must the result be, unless a very liberal supply of food is administered, and as the spring advances great care will be required in giving it, or robbing will be induced.

I would say, feed at the top of the hive in all possible cases; and I still hold, that for spring feeding, barley-sugar is the best, and I give a receipt below for its manufacture, which, perhaps, is a little more simplified than the one I gave two or three years since.

EARLY BREEDING.—I am well aware of the advantages of early breeding, and have both used and recommended various modes for promoting it; but in such a season as the present one, unless the greatest vigilance be observed in supplying food, that which is usually esteemed a great advantage will now become a positive calamity.

CLEANING FLOOR-BOARDS.—When performing this operation, should the hives be found to be at all damp or mouldy, take the precaution of raising them a little for a few hours, on a dry day, in the manner recommended in the calendar for last month.

SNOW.—Should we, after all this mild weather, have snow, it will be necessary to keep the entrances of the hives stopped whilst it remains upon the ground, or the loss of life will be very great, which at this season should be more especially guarded against.

TO MAKE BARLEY-SUGAR.—Put two pounds of loaf-sugar into a saucepan, with half-a-pint of water, and two spoonfuls of the best vinegar;* put it on a gentle fire, let it boil till the syrup becomes so thick, that the handle of a spoon being dipped into it, and then plunged into cold water, the syrup upon the handle is found to be quite crisp: when this is the case it is sufficiently boiled. Have an earthen dish or marble slab in readiness, well buttered; pour the syrup upon it, and, when sufficiently cool to handle, clip it with scissors into strips the size desired. The process of boiling takes about twenty minutes.

POLANDS AND HAMBURGHES.

I THINK I must trouble you with another Poland *versus* Hamburg letter, wherein I will write a side-by-side description of Polands, Black, White, and Spangled, and of the *Tufted*

* The addition of the vinegar prevents the sugar from graining, or crystallising, which otherwise would frequently happen, and in this state it is useless to the bees.

Hamburgs, Nearly Black, Laced, and Pheasanted, for you seem inclined to admit a distinction, but still call the Dutch Every-day-layers, Hamburgs. I hope, however, that you will clear up this mistake before your new work comes out; as also that of the new fashion of calling a black spot a spangle, for as long as I have known the fancy fowls, these black spots were called pheasanted, and spangles were those white spots on a darker ground, and I think you will find many old fanciers of the same opinions. But the true Poles having almost passed away, and with them the real Spangles, their names have lately been applied to the Hamburgs, and their name slipped on to the Dutch or Bolton.—B. P. BRENT.

[Whenever a catalogue of any Poultry Society, during the last few years, is taken up, we find prizes offered, amongst other breeds, to *Polish* and *Hamburgs* in their several varieties. When the time comes, and we find ourselves in the exhibition-room, we see the pens assigned to *Polands* occupied by birds of different plumage indeed, but, whether black, gold, or silver, with one distinctive characteristic feature, and that is, a prominent, fully-developed *top-knot*, with a diminutive, spiked comb. Let us go a little further, and we reach the location of the *Hamburg* family. Here, again, we have diversity of colour, but uniformity in one striking feature—"a full rose-comb:" one recognised and most essential feature of this class; but a *tufted* or *top-knotted* bird, claiming even remote cousinship with the *Hamburg*, would there both merit and meet with speedy expulsion. Now, let it be remembered, that we are here contending for no mere personal notions of what, in our own idea, should constitute the distinction between different families of fowls, but are simply referring to the rule which hitherto has been acted on at every Poultry Exhibition at which either we ourselves have been present, or of which we have read the report. We must acknowledge, therefore, our adhesion to this general opinion, that the "*Tufted Hamburg*" is rightly excluded from any system for the classification of fowls. For, amid the diligent scrutiny with which, of late especially, every matter connected with the detail of our Poultry Societies have been investigated, it is most impossible to say, at least, that such an error in nomenclature, as Mr. Brent would imply the existence of, could ever have received the general sanction of all concerned. Just so, too, with the *Spangled* birds. Ask any one of those who have acted as judges at our Exhibitions for his definition of the meaning of the word, and then look at the pen which is honoured by his award. What markings have the birds within? Whether silver or golden, as in the case of the *Hamburgs*, we find the ground colour clear French-white, or bright bay, as the case may be, and the "spangle" itself a more or less perfect oval spot, of *dark* colour, occupying the extremity of the feather. East, west, north, or south, we find the pens allotted to spangled birds thus occupied, while the public sanctions the award. If an argument, however, be drawn from the literal definition of the word spangle, as that which shines or glitters, and it be thence inferred that its colour should be white, we would submit that a dark object on a light ground might equally well fulfil the terms of the definition as a white object on a dark ground. But, though differing on these points, it is but just to remind our readers that those who have lately derived so much interest from studying the habits of the various breeds of poultry, owe much to Mr. Brent and others, who, at a period when the details of the poultry-yard were usually regarded as utterly unworthy of any serious consideration, persevered with the same earnestness and assiduity as is now called forth by the popularity with which poultry has been lately invested. Our thanks are indeed due to them; and although it unfortunately happens that in this question of "*Poland versus Hamburg*," we find ourselves at variance with him, his frequent contributions to THE COTTAGE GARDENER must have been read by many with the same interest and profit as we ourselves have undoubtedly derived from them. Our present definition of the distinctive points and characteristics of these two varieties, as also that of the word "spangle," rests on what we conceive to be the declared opinion, as evidenced by their practice, of every Poultry Society in England. And thus, taking even the lowest ground, it would surely be admitted that, with such unanimous assent of competent

authorities to the meaning of certain terms, it must demand stronger facts than have yet been brought before us to induce us to hesitate on the propriety of their present application.—W.]

MOVEABLE GARDEN SCRAPER.

I HAVE observed, for some time past, that you have been most laudably enlightening your readers as to the best description of that most useful implement, a garden scraper. There is no objection to be made to those already submitted, which are good and useful in their way, but they are fixtures, and may not be to hand at the moment when most wanted. I have, therefore, much pleasure in sending you a drawing of one, which I have had in use for many years.

It was invented by a gentleman in Hertfordshire, and it is not, therefore, surprising that I should never have seen it elsewhere than amongst those of my friends who have taken mine as their model; otherwise I should feel inclined to say, "I cannot think how any one can do without it." Nothing can be more simple, and yet nothing more useful, particularly for amateurs of the fairer sex.

The handle should be made of a light and elastic wood, so that it be as easily carried about in the hand as a hoe. It is stuck into the edge of the bed upon which one may be going to employ oneself, and is ready for use before the foot be again placed on the gravel or lawn.

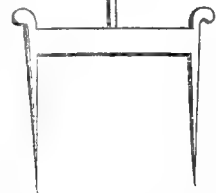

It may be useful to some to know that mine were made by Messrs. Nunn and Son, of Hertford.—H. S. WATSON, *Tollington Park*.

CROSS BREEDING.

MR. SHEPPARD, in alluding to a communication of mine in your paper of December last, must mean that *deterioration takes place in the breeding of sheep when they are bred-in-and-in—that is, bred in the same family*; and if the breeding is continued any length of time, that "they degenerate to a marvellous extent with every generation, until at last the sheep become quite weak and sickly, having none of the characteristics of purity and health;" and if this is what he means, I perfectly agree with him, and do not think any of your numerous readers will even for a moment question the truth of his statement. But if Mr. Sheppard means that sickness and deterioration will only take place when the animals are cross-bred, and the breeding continued in the same family, then I differ from him in *toto*, and say that deterioration will take place whether the animals are originally crosses or pure bred, if the breeding is continued in the same family. This, I should think, no one will question who knows anything of the breeding of animals. All our domesticated animals having originally come from some wild type, and having a common root, I cannot see how, by any possibility, that crossing animals of the same species, but who, through length of time and careful breeding have attained some good qualifications, with another having other desirable qualifications equally permanent and well marked, should in any way lose their qualities by being crossed with the best of their respective classes. Should I be foolish enough to take the progeny resulting from such an union, and breed them in the same family from the same parents, the results would be as Mr. Sheppard states. But surely, no one who knows anything of breeding would ever for one moment think of such a line of policy. Let Mr. Sheppard take the best Cochins in his yard, and subject them to the same test for a year or two, and then let your readers have a report of *their* progress. I doubt not your readers will judge, *a priori*, the end from the beginning.

My belief is, if a few parties were to cross the Spanish with the Cochin, starting from fowls not at all related to

each other, that a distinct breed could, in the course of a few years, be reared, uniting, in a great measure, the good qualities of both by carefully selecting the fowls from which the breed was to be perpetuated, carefully changing the male or female from one to another, taking care to have the breeding fowls as far as possible from being related to each other; and I am convinced if such was the case, no such deterioration would take place, but, on the contrary, an improvement, and that not fancied but real; and it can only be by taking advantage of the varied qualities and forms of nature's work, that the variety of our domesticated animals have been increased and improved; and I think any observant person, much acquainted with animals, may reason *a posteriori* from results within reach of his own experience. But in the midst of counsel there is wisdom. I hope much good will be the result of the many inquiries regarding poultry, and articles on the subject from time to time appearing in the pages of *THE COTTAGE GARDENER*, making it now an authority on these hitherto much neglected matters.

My object in addressing you is to bring out information on a subject which I think not sufficiently understood and taken advantage of. How, I would ask, have we obtained such variety in the vegetable world? Is it not by taking advantage of nature's freaks? And why, in the animal world, are we to abandon a principle which, in the vegetable world, has given us such magnificent results. Nay, I need not say such a principle has been *confined* to the vegetable world. If it had, our animals would have never reached the state of perfection in which we now find them. That all our finest and prize animals have been reared by placing a standard of perfection before us, and breeding only from those animals who come *nearest* to the point aimed at, is what no one can question; and why we should abandon it in the rearing of fowls I am at a loss to understand.

I think your correspondent, Mr. Sheppard, is rather too severe on those experimentalists in the Esculapean art who will not "throw physic to the dogs." I admit, at once, that little is known regarding the art, in so far as the feathered tribes are concerned; that in a great measure it is mere empiricism, certainly not grounded on anything like a solid foundation; but surely should we stumble on something of decided value in the cure of a particular disease, it would be worse than folly to shut our eyes to the *fact*. If we did so, we might have appended to our cognomen the appropriate epithet of bigot, and we should have no right to complain of the addition. The cure of the dumb creation is, however, and must be, from the very nature of the subjects, a very difficult profession. They cannot answer our interrogation, but only by silent and often painful expression, not however translatable to be of sufficient use as a guide to the medical practitioner. But I hope, from so much more attention being now bestowed on these matters, in consequence of the increase of poultry keeping, something may be found out to alleviate their sufferings, or cure them of their maladies.

It has appeared to me that the Cochins when young are the hardest of birds, but that they are very subject to disease as they grow up, exactly the reverse of our common kinds of poultry; and this, I think, may be accounted for from the damp of our climate (the birds not being yet acclimated) during the autumn, winter, and spring; the *summer*, when they are hatched, being often dry and warm, is favourable to them as chickens; but when beyond their chickhood, wet, damp weather surrounds them, and various diseases follow in its train. Last autumn (end of September) I put a dozen eggs below a hen, and ten chickens were the result; for a fortnight, while the weather was dry, they did as well as chickens could do, even in the summer; but all at once, one after another, gave way in the legs, until there lives, at this moment, only one solitary and miserable looking creature, to point a moral and tell a tale of suffering and woe. It was an experiment, but one I will not repeat, for I feel it was one of cruelty to the poor dumb creatures.

I shall be glad to communicate to you how the crosses succeed after a while.—A. S. W.

ECONOMICAL HEATING A GREENHOUSE.

In this very varying climate of ours (Ireland), we amateurs who do not profess to keep even "a handy man," have many difficulties to contend with, and not the least amongst them

is the protection of our greenhouse plants from sudden and unexpected falls in temperature. True, the climate on the whole is mild, so much so, that up to the 1st of this month (February), I have not had occasion to light my furnace more than three times. Now the frosts of these three nights were clearly indicated in the early part of the days, or, at all events, previous to night setting in, and in these cases there was no difficulty in being prepared for the icy king; but since the commencement of the present month we have had several sharpish and injurious white frosts towards the break of day, (and these after determined wet days, continuing up to midnight); and it is here that the amateur, who has retired to bed quite satisfied of having no frost for that night, finds to his sorrow, on looking over his pets in the morning, that some of the most tender have all but perished.

To guard them against these vicissitudes is what I want to accomplish, without the toil of lighting fires constantly. Now I am passionately fond of my greenhouse plants, of which I have a large and various stock, and often as I sit over my parlour fire I think it a pity that I have not made it available for the protection of my plants, in fact, we do not receive half the benefit we might from our fires.

The exclusion of frost, or the ranging of the thermometer between 35° and 40°, is all I aim at, for in the case of very severe and continuous frost I can heat my brick flues. I would now, therefore, crave the benefit of a share of that mass of intellect which is brought into operation in the varied and excellent articles that appear in the pages of THE COTTAGE GARDENER, in carrying out my project, and

1st. Could I not set in the back of my parlour-grate, or, indeed, in the kitchen fire-place, which is just as convenient, a small copper boiler made to fit in the back of the fire-place, and have hot water piping running from thence into the greenhouse? I am sure you will answer me, "You can, to be sure."

[You are quite right in your anticipation of our answer. You can accomplish what you wish by imitating the arrangement of pipes adopted by Mr. Bradbury, of which a plan was given in our last number, p. 387.—ED. C. G.]

2nd. What sized lead pipe would be necessary for the flow and return pipes which are to connect the boiler and the iron pipes in the greenhouse, for, mind you, there is a distance of thirty feet between the kitchen grate and the greenhouse; and, in addition to asking you *what bore* will be necessary for the *conducting pipes*, I must also ask you, after what manner shall I lay them in the ground, so that as little cooling as possible may take place in the transit of the hot water for the said distance of thirty feet.

[Do not use *lead pipes* at all. If your greenhouse is small, three-inch cast-iron pipes will answer your purpose if carried the whole length of the house and back again. To keep the pipe from cooling in the thirty feet underground, you cannot use anything better than a six-inch covering of dry sawdust all round.—ED. C. G.]

I propose so to set the boiler that I need not let the kitchen fire act on it but when I please; this can be done by the removal of a fire brick, a furnace door, or such like. If I can accomplish all this, I can let my kitchen fire remain for the night during all suspicious weather, thereby producing warmth from the hot-water apparatus sufficient to keep out frost without exciting, and thereby attenuating the plants. It would also save me many anxious hours on nights which would not justify the heating of the present brick flues, very *troublesome* and very *dirty* work for the *amateur*.

[We like your idea of only having the apparatus heated when you wish. This might be accomplished by means of a false back of cast iron, made so as to slip in and secure a vacancy of two or three inches between the fire and the apparatus. The air in those two or three inches would form the best non-conductor of heat.—ED. C. G.]

The objects to be attained are,—

1st. An almost inexhaustible source of gentle heat, at all times wanted, from a fire constantly at work for other purposes, and without, I may say, the cost of fuel.

2nd. The immense saving of trouble, cost, dirt, and expense of lighting outside fires in the flues, which want con-

stant attention, and which very often fail to give out heat at that period (the break of day), when most needed, and when the amateur fancies all is right.—A CONSTANT SUBSCRIBER.

DISEASES OF POULTRY.

EXHIBITION FEVER.

I AM rejoiced to see you taking up the subject of the late Birmingham Poultry Show, and can fully bear my testimony to your remarks, having been a sufferer myself. I bought a pen of Dorkings, and, when they arrived, two of them were much affected with a disease in their eyes, and one could scarcely eat. They have infected all my poultry. The cock I purchased is since dead, and one hen still very ill, and all the rest suffering, more or less. Now, it does seem to me that every care should be taken by the authorities to prevent *diseased* fowls being admitted, which I understand they were, and, indeed, on the Tuesday I was there, I saw some myself in that state, and considering the value of the poultry, and the high prices given for them, it is vexatious to lose them by a carelessness which might be prevented.

As your correspondent, Mr. Tegetmeier, is kindly writing on the diseases of fowls, I should much like to know what he considers the proper treatment for this complaint. The symptoms are, eyes closed with froth, a stretching out of the neck, with constant husky cough, total loss of appetite, and evidently great pain in swallowing food put down the throat. I tried the pill recommended in one of your numbers, of hydriodate of potash, and gentian-root powder, which I think has done good. The pain, however, of swallowing became so great, it seemed cruel to force food down, and, as a last resource, we pinned a mustard poultice round her throat for ten minutes, when she evidently felt it. The relief to the throat was immediate, and she has since swallowed the soft bread and water put down her throat without pain. Two days after we repeated the mustard poultice, always continuing the pill. The hen, though still very ill, is now able to peck a little herself, and seems to have some appetite, but the eye still requires the froth to be constantly removed. Her excrements are quite green and loose. The rest of the fowls have the cough, and a little froth on the eye, and have suddenly stopped laying; and I should be glad to know what to do for them.—W. A. E.

[It will not be until after many of the most valuable poultry yards in the kingdom are depopulated by this contagious disease (which has been so characteristically named by our Editor "the Exhibition fever"), that the time which the fowls are kept in an over-crowded show will be shortened, or the gross feeding with greaves and other stimulating animal food abolished.

For typhoid fevers of this kind, whether known as gaol fever, exhibition fever, &c., there is no cure. The only mode of treatment that can be recommended, in addition to the precautions advised at page 371, is to treat the symptoms as they arise. If, as in the above case, the liver is much affected, as indicated by the green dung, I would give one-grain doses of calomel every one or two days. The mustard poultice to the throat, to relieve the inflammation there situated, I regard as exceedingly judicious treatment. Not so, however, the hydriodate of potash, which has an irritating effect on the lining of the throat, stomach, &c., likely to prove detrimental.

Should the bird appear sinking from weakness, a little stimulant might be very advantageous, such as weak brandy and water, or ale, given in small quantities, at short intervals. I very much deplore the time for which fowls are detained at the shows, and am quite confident that it prevents many sending their birds. So great is the dread of the disease, that one of the most successful exhibitors told me, he sold all his pens at the Great Metropolitan, some at a very great sacrifice, rather than take them home again to the risk of injuring his stock.—W. B. TEGETMEIER, *Tottenham*.]

INFLUENCING THE SEX OF CHICKENS.

MOST persons are aware of the existence of the idea, as old as the time of the Romans, that the sex of the chicken

can be ascertained from the shape of the egg. A slight acquaintance with the anatomy of the fowl would disprove the truth of this statement. The germ of the future bird is formed with the yolk in the ovary, and as it passes along the egg-passage—a tube upwards of two feet in length—it receives in its progress the white, the skin, and, lastly, the shell; these being formed or secreted by different parts of the canal, it is evident that the shape of the egg depends on the shell, which is formed after the whole interior of the egg is completed, and can, therefore, have no influence upon it; moreover, the alleged fact has been disproved by experiment. I believe, however, that it is in our power to influence the sex of chickens to a very great degree. In the first number of the Quarterly Journal of Agriculture, is related some experiments on sheep, in which two flocks, of 135 ewes each, were made to produce—one, 80 male lambs to 55 females; the other, 53 males to 84 females. It appeared from these experiments that the sex of the offspring was chiefly influenced by the age of the male parent; and I would suggest that those of your readers who have the opportunity of experimenting on this matter should do so, and I think it will be as follows:—When a young cock is mated with old hens, there will be a much larger proportion of pullets hatched than when an old cock is paired with young hens, in which case the males would predominate. Again, when both parents are in their first year, I would expect more pullets than cockerels. I am now trying the experiment myself, but a single experiment proves nothing. If those of your readers who have the opportunity of observing would do so, and send me the results, I would collect them into a tabular result, and thus, from many cases, the truth of the opinion might be tested in one season. I need not stop to point out the great importance of the suggestion, if true; breeders for the table, and those for stock, require the greater number of birds of opposite sexes.—*W. B. TEGETMEIER, Tottenham.*

TO CORRESPONDENTS.

MELONS AND CUCUMBERS (W. B.).—Your three-light frame will be just the thing for these, provided you have hot dung, or tan, to form the bed; leaves alone, we fear, will hardly do, the autumn and winter was so wet as to perish them too much for effectively heating a hotbed. Turn and mix your heating material, as recommended so often by our departmental writers; and when it has attained a sufficiently modified heat, make up a hotbed, and place your frame on it; and the one intended for cucumbers ought to have a much lighter soil than the one for melons; but neither ought to be put in for at least a week after the bed is made up, and only then if the heat be moderate. Mounds at least fifteen inches high should be made under each light, and the plants planted out the next day or so, as the soil ought to be well warmed. We have supposed that, as you say you are a beginner, you may have made friends with some kind neighbour, more experienced in such matters, who supplies you with plants; but if you determine on raising them yourself, you must first prepare a sort of hotbed, as a nursery, where you can sow your seed in pots to plunge in the heating matter; and when the plants are up, they may be potted off in pairs; and when they have got the second rough leaf, they are then fit to plant out in the hills; but if you can get a kind friend to do this preliminary part of the business, you will husband your heating material, and remove many difficulties in the way of an early crop. Other particulars relative to the melon, &c., will shortly follow in our pages, which we have no doubt will meet your case.

MANDEVILLA SUAVEOLENS (Ibid.).—This fine evergreen climber is best propagated by slips or cuttings of the young shoots when two or three inches long; but then they must have the benefit of a mild, steady bottom-heat, and be covered by a hand-glass; this system, however, can only be successfully carried out by nurserymen and others, who have many things to propagate, all requiring the same treatment. If, therefore, you only want a plant or two from the one you have, try and layer a shoot into a flower pot, which may be secured in some way or other, and you will have a plant much sooner than with cuttings.

RED SPIDER (Ibid.).—Moisture will usually overcome this pest; but when that cannot be applied, compatibly with other things, sulphur will effect the same purpose. Dust, therefore, the leaves of plants suffering from it with flowers of sulphur, and repeat the dose if required; but some plants, like the melon, cannot endure sulphur. If, therefore, moisture be unable to combat this evil, painting the inside of the frame or pit with a mixture of this and clay, will, by the fumes emitted, generally effect a cure. But you will, doubtless, hear from us again on this subject.

RENEWING AN OLD GARDEN (R. H. GILL).—Your many queries relating to the formation of a new, or renovating an old garden, will be attended to in our next, as we have forwarded your note to one of our departmental writers, who will, no doubt, give you all the information you require; in the mean time, you are perfectly right in digging or trenching the ground as a preliminary operation, but you must take care and not turn up any useless or pernicious matter to the surface. If your soil be shallow, there is no harm at digging up the subsoil, but it must remain as *subsoil still*, keeping the top spit to the top again; but more details will be given next week.

PROPAGATING PIT (W. B.).—Your small cucumber pit might easily be converted into a propagating pit for soft wooded plants, but would be too moist for heaths and the generality of New Holland plants. You best know whether part of it could be spared for propagating purposes. If you have more cucumbers than the family require, then you could spare part of the pit. The part for propagation should be divided from the part devoted to cucumbers; for though some cuttings, such as dahlias, for instance, would strike easily enough in the pit with the cucumbers, yet many others would damp off; besides, places crowded with plants are not desirable. Your cucumbers would soon be full of red spider and thrip from the cuttings. To describe the propagating power at Pine Apple Place, referred to by Mr. Appleby, would occupy too much space here. As it appears you have seen his description, why need we repeat it?

HEATH PROPAGATING AND SPECIMEN GROWING (A FIFE READER).—We cannot say where you can buy "Cushing on Propagating;" but if you had it, do not suppose that either science or practice has slept since his days. You have stated you have read Mr. Fish's papers carefully lately, and do not find directions minute enough. His late article on propagating was written for a special purpose; a house of Heath cuttings being adduced as an illustration. With every wish to oblige, we cannot agree with you, that while other "*manias*" are attended to, there has not been a word about Heaths. Nor can we think that as an "*Old Subscriber*," you could have read with great attention the papers on Heaths, not so long ago, even by Mr. Fish alone, or you would have met with the most minute replies to almost every enquiry you make. See general remarks, and raising from seed, No. 167. Propagation by cuttings; sand, soil, pots, glasses; time of making cuttings; condition of ditto, size of ditto, mode of making, inserting, watering, position, and general treatment, Nos. 168, 169. Potting, drainage, compost, growing, watering, temperature, winter blooming, 173, 174, 178, 181. Pruning, training, 185. *Position*, according to season and kind, &c., 187; besides notices, lists for different purposes, &c., in many other places. All the most difficult hard-wooded plants have also received minute attention. Very likely there will be additional articles before long; but what has already appeared will insure success, if duly practised and persevered in. You will find some other matters referred to to-day about which you enquire.

FUCHSIA SERRATIFOLIA (Gladiolus).—This, growing in a window, without fire-heat, is very rampant, but very lanky, and showing no sign of flowering; but it bloomed in autumn. "Shall I cut down now, or when?" You may place it anywhere now, where it will have some light, and be free from frost; prune it well back in March or April, and then give it as warm a position as you can, and, when it breaks, plenty of light, and then it may receive fresh soil. If you want plenty of bloom in the autumn and the first part of winter, you cannot do better than plunge the pot out-of-doors in June. Mulch, and water well in summer; and raise the plant in October, when, probably, the roots will be so over the old pot that a larger one will be necessary. It will require to be kept in a shady, airy place for a fortnight.

ERRATA.—At page 323, under 3rd, first line, leave out "*not*"—it will then read, "allowing that bell glasses are essential." Page 364, third line from the top, "*distraction*" for "*destruction*."

CALCEOLARIAS FOR BEDDING IN SHADES (S. S.).—There is only one nameless variety, a reddish-brown shrubby one, that will mix with yellow shrubby Calceolarias for shading. But *Amplicaulis*, *Kayei*, and *Rugosa*, will give three shades of yellow, in three distinct beds, in a group of yellows. *Kentish Hero* does not shade or agree in habit with any other kind for mixing. The shading of Calceolarias can only be effected where the planting is intended for match beds, or for giving different degrees of height; then, each bed is of one plant, and in a different shade to the opposite bed, in matching, or the next bed in height, when three heights and three shades is the arrangement; and all Calceolarias are better without borders.

CINERARIA AMELLOIDES (Ibid.).—We never knew it to seed. It is to be had only in plants, and it is altogether a different thing from the pot Cinerarias, so called, because not one of them will do in a bed. *Arabis grandiflora*; the double *Cardamine*; and the *Iberis Saxatile*, can be had in plants, but not by seeds, about London.

TORONIA ASIATICA (L. M.).—This is one of the easiest of all plants to root from cuttings, to grow very fast, and to flower most profusely, in a strong moist heat—first in hotbeds, and in the stove afterwards. After it comes into full bloom—say in July, August, and September—it would do very well to stand in a greenhouse. Very good gardeners could so manage with a common hotbed and a good greenhouse, but "young beginners" must not expect to succeed like old practitioners.

VINERY (Ibid.).—You have made a sorry choice of Vines. The *St. Albans*, although one of the very finest-flavoured grapes, cannot be had in perfection except from such men as Errington and Fleming. The berries, in general, are hardly fit to be seen—cracking and damping before they are quite ripe. The *Black Alicant* and *Black Frontignac* are not worth house room. The *White Frontignac* will only answer in one place out of ten, unless it is grafted on a hardier sort; and from such a house as you contemplate the *Canon Hall Muscat* will be no better than old leather gloves. A mistaken wish for novelties, and a premature desire to imitate first-rate gardeners, are the two rocks on which "amateurs" and "new beginners" get wrecked every month in the year. The old *Black Hambro* and the *Royal Muscadine*, or even the common *White Muscadine* and the *Black St. Peter*, never yet failed, and they are as good grapes as the very best you can pick out of books. The *Millhill Hambro*, and all other *Hambros*, and the *Barbarosa*, are grown to perfection by Mr. Fleming, but very likely it would take ten or fifteen years' practice before you could grow them fit to be seen. Whoever told you that the *Millhill Hambro* requires to be left to itself, to "grow away like a bramble," took you to be worse than a simpleton.

EATABLE-ROOTED TROPEOLUMS.—A correspondent (*Wareham*) says: "In answer to W. D., the tubers of *Tropeolum tuberosum*—if that is what he means by *Tropeolum edule* (No.)—may be boiled about ten minutes, and the water being poured off, set the saucepan on, or close to the fire, for a few minutes, as with potatoes, and they may be served with white sauce."

ROSE PRUNINGS (Wareham).—The tops of all China, Bourbon, and Tea Roses will do for cuttings next March, when you prune them, as you can give them a slight hotbed assistance. The very young wood of Hybrid Perpetuals, Noisettes, and most of the climbing Roses, will also do for cuttings.

SIZE OF HYACINTH BLOOMS (Ibid).—"How many tiers of pips should a good Hyacinth have on an average?" For exhibition purposes it should not have less than five tiers; but some varieties cannot be induced to produce so many. This variation in their power of producing large spikes of flowers renders the task of judging of the skill of the grower rather difficult. The judge should know the habit of each variety. See our 79th number.

HYDRANGEA (M., Fermanagh).—There is something wrong with the soil, else your plant ought to be in great beauty in the north of Ireland. Let a trench, a foot wide, be opened all round it; and let the soil be worked from the roots into this trench, with a garden or dung-fork. Then fill up the trench with good fresh earth, or peat and loam, with a little rotten dung, pressing it well to the roots. This should be done about the end of March, and by the end of April cut down the plant quite to the surface of the ground. You will thus get rid of the hard, dry, hide-bound wood; and next summer a fresh growth of luxuriant wood, aided by your new soil, will come up, and in due time flower with great brilliancy. Cuttings from the old tops would only perpetuate the botheration of past years. Stop till you get young healthy wood, and then make cuttings of it every spring. To cover the high wall, first of all make one of the best borders in all Ireland, two feet deep, dry at bottom, and four feet wide at least, then plant *Clematis montana*; *Roses*—*Felicite perpetuelle*, *Princess Louise*, and *Myrianthes*. These will soon reach up to twenty feet; and to cover the lower parts, use more *Dwarf Roses*, or any other climbers from our former lists; almost any thing will grow in such a border. *Tropaeolum pentaphyllum* would be the admiration of that part of the country in such a border; and so would *T. speciosum*, *Clematis varulea grandiflora*, *C. Sieboldii*, and *Solanum jasminoides*.

PURE BREEDING (O.).—As you have had three varieties running together, you cannot with certainty have pure birds from any of them until late in the season. If you separate them now, the eggs laid by them cannot be relied upon as true until after the lapse of twenty-three days, according to Capt. Hornby's experience. Some persons consider the taint of an intermixture remains for life.

SULPHUR FUMES (A Country Curate fond of his Garden).—If these have been excessive, or if the heat in the forcing house was so high as to produce sulphurous acid, either the edges, or the whole surface of the leaves of your plants would become brown, just in proportion as the sulphurous acid was in less or more excess.

CINERARIA SEEDLING (J. R. Jessop).—Colour, a good purple lilac, with blue centre; small, but petals imbricate well, and are only slightly notched. It is a second-rate flower. We cannot name it.

SHANGHAI FOWLS (J. B. F.).—We are aware that many imported direct from Shanghai have no feathers on their legs; and we know of no reason why a class should not be had for them at poultry shows, except, perhaps, that it would give an opportunity for mongrels to be shown in it.

SHANGHAI EGGS (R. Hill).—Their average weight is 2½ ounces; the colour varies, even in the purest bred birds, from nearly white to dark chocolate. For hatching they should not be more than a fortnight old; but how old they must be to become unhatchable has never been determined.

OYSTERS (G. Jones).—When they are on the ground they rest with the flat shell downwards. That they can turn themselves over is certain.

BREEDING IN-AND-IN (G. B.).—To avoid this get some one to exchange cockerels with you.

EXEMPTIONS OF AGE (Spero).—Sixty years entitle you to exemption from serving as a juror and as a petty constable, but we think from no other office. Such questions, however, are not within our province.

RABBIT-FENCING (G. T. S.).—You will be quite safe with galvanized iron-net-work, two-and-a-half feet high. See Mr. Fox's advertisement.

VINE-SHOOTS DROOPING (G. Smith).—The case is clear enough. All your vines now forcing are doing well except one, and that one is the only one which has its roots outside the house. The cause of its leaves flagging, we think, is that the roots do not keep up a sufficient supply of sap, and the only remedy is to cover them with fermenting dung. The activity in the roots must always keep pace with that of the branches.

PROTECTING MATERIAL (A Constant Reader).—There is nothing better at present in the market, whether for shade or shelter, than canvass or coarse calico.

FANCY RABBITS (J. T. M.).—We must not recommend dealers: and those who have any to sell may do themselves and us justice by advertizing.

PYRAMIDAL PEARS (Amicus).—Unless you require them to be dwarfs, you must not have them grafted on Quince stocks. Our experience sustains the opinion that those grafted on the Quince stocks bloom earlier than those on the Pear stocks, and therefore suffer more from the spring frosts.

HEATING GREENHOUSE BY GAS (A. B. Webber).—You may exclude frost by having a gas-stove in your greenhouse; but the fumes arising from it must be carried cut-of-doors by means of the stove's chimney.

BRAMAH POOTRA FOWLS (Several Correspondents).—In our opinion they are only a cross, and a bad cross too, between the Shanghai and the Malay. The specimens we have seen are coarse and leggy. There has been no time yet to test our opinion, but we shall be surprised if the produce of a White Shanghai hen and a Malay cock are not Bramah Pootra chickens.

CALENDAR FOR MARCH.

FLOWER-GARDEN.

ANNUALS (Tender), such as the *Portulaccas*, *Mesembryanthemums*, *Lobelias*, &c., sow, b.; (*Hardy*), sow on dry borders, b. and e.; finish transplanting *autumn-sown* annuals. **BIENNIALS**, sow, e. **CLIMBERS**, half-hardy, as *Maurandya*, *Lophospermum*, &c., pot and train, b., to have strong for next May planting. **CUTTINGS**, push on the propagation of cuttings, and transplant them as fast as they root. **CUTTINGS** from *Rose* prunings, plant in the shade. **DAHLIAS**, sow, and force old roots for stock, b. **DRESS** every part within the boundary as early as you can. **EDGINGS** of all sorts finish off as early as possible. **ALL EVERGREENS** transplanted since last August may have liquid-manure this month, and throughout the season after this mild winter. **FLOWERS**, pick off from plants you want cuttings from, b. **FINISH** all the **PLANTING** and **SPRING PRUNING** of trees and shrubs, and all necessary alterations, as soon as the weather will permit. **GRASS**, and white and small yellow **CLOVER SEED**, sow with a liberal hand over patchy grass; keep the grass in clean, trim order, and roll it three times this month, and oftener if you can. **GRAVEL**, clean, roll, and relay. **HAND-GLASSES** are the best of all aids to rear half-hardy, and such other annuals as come up weakly at first, place them on a warm sheltered aspect. **HOING**: never hoe a border in March, for fear of killing something which you cannot see. **HOTBEDS** are only good helps to those who can well manage them for the flower-garden; keep them up to 70°, and steady. **HYACINTHS**, and other **BULBS**, as soon as they appear, stir the beds, and lighten the soil round the plants; and plant spring **GLADIOLI** at once. **PERENNIALS**, with the exception of long fleshy-rooted ones, ought to be removed—divided, if necessary—and receive some fresh soil, or be planted in new situations, at least every third season; see to this rule, and treat one-third of each family, every February and March, according to it. **PROTECTION** is necessary for almost all young things of a tender nature this month. **RAKES**, lock them up, b.; if your man cannot dress a border without a rake, tell him he must learn. **ROSES**, finish pruning, b., except, perhaps, a few strong ones may be left unpruned till April, to bloom later; but this plan is radically bad, and not necessary now with our perpetuals. **SEEDS**, do not sow a packet of rare seeds in one pot only, sow in two or three pots, to provide against accident to one. **SEEDLINGS** in heat, transplant as soon as you can handle them. **STAKES**: see if you have a stock on hand for your Dahlias, Hollyhocks, and all other plants requiring them next summer, and see that all the old ties and rotten stakes are out of the rosary. **SWEET BRIAR**, sown in a single row, will grow and make a hedge in such poor soil as would kill other roses. **TURF**, lay. D. BRATON.

FRUIT-FORCING.

AIR, increase as forcing proceeds. **APHIDES**, destroy. **CUCUMBERS**, in forcing-house, apply liquid-manure, train and stop when long enough; in frames, turn and remove linings weekly, stop frequently; temp., 65° to 75°. **CHERRIES**, use moderation; keep a humid air; temp., 50° to 60°, artificial heat; ventilate freely. **FIGS**, such as *Peaches*; keep the root moist; bottom warmth benefits them. **LIQUID MANURE**, apply to active growths where strength is required. **LEAVES** of all fruits keep clean. **MOISTURE (AIR)**, supply liberally; root moisture regularly, but according to need. **MILDEW**, beware of; see *Sulphur*. **PEACHES** and **NECTARINES**, keep a free atmosphere; disbud and train; temp., 55° night, 65° to 70° day. **PINES**, liberal heat and moisture to rising or swelling fruit; successions, rearrange and increase temperature. **RED SPIDER**, see *Sulphur*. **STAWBERRIES**, introduce successions, water liberally, keep near the air and light. **MELONS**, bottom-heat 75° to 80°, air-heat 70° to 80°; thin the Vine well. **SULPHUR**, apply at least monthly in all structures. **TEMPERATURE**, allow 8° or 10° advance in heat during sunshine. **VERMIN**, entrap. **VINES**, early-train, stop, thin berries, tie shoulders; do not forget the sulphur. **WATERING**, attend to daily. R. ERRINGTON.

FRUIT GARDEN.

APRICOTS, protect; search for the eggs of the Red-bar Moth, like parsnip seeds, and dotted. **APPLES**, cleanse, brine and soft soap, succeeded by spirits of turpentine in the retreats of the American blight. **BLOSSOMS**, retard and protect. **BUSH FRUIT**, still plant or top-dress. **FIGS**, uncover, prune at end. **GRAFTING**, proceed with. **HOING**, practice on foul borders. **NUTS**, hang male catkins among the female blossoms. **PLANTING** of all kinds instantly bring to a close. **PEACHES** and **NECTARINES**, finish training, retard and protect; dress the walls with sulphur paint. **RAPBERRIES**, still plant, prune, stake, and top-dress. **ROOT-PRUNING** may still be done. **SUCKERS**, destroy. **STRAWBERRIES**, spring-dress; transplant. **STANDARDS**, stake. **STOCKS**, plant or sow seeds. **TRELLISES**, dress and protect. **VINES**, plant at end. **WALNUTS** may be planted still. In *grafting*, proceed according to the degree of development of the bud, taking each kind the moment the buds actually begin to expand. R. ERRINGTON.

GREENHOUSE.

AIR, admit in fine weather, when the outside temperature is above 35°; a shut house is better than cold currents and night fires; in foggy weather, however, light a fire, to clear and dry the atmosphere. **BULBS** and **TUBEROUS** roots, introduce, and water more freely; start the various kinds of *Achimenes*, *Gesnera*, and *Gloxinia*, in hotbed; seeds of the latter, sown now, will give nice little flowering plants for the autumn and winter, if you can give them heat. **CALCEOLARIAS** and **CINERARIAS**, water more freely; give manure water to those flowering and showing their flower-stalks; shade in sunny weather; shift for succession **CAMELIAS** and **AZALEAS**, water more plentifully when in bloom; keep those intended for late blooming as cool and shaded as possible, so that frost does not injure them. **DIOSMA**, **EPACRIS**, **HEATHS**, give abundance of air when growing and flowering; Prune freely when done flowering, and keep close until they begin to grow, when the roots had better be examined. Now and afterwards, for a couple of months, will be a good time for inserting cuttings. **HABROTHAMNUS ELEGANS** is

now a pretty object, grown in a pot, or trained against a pillar. **HOT-BEDS**, prepare for sowing *Primula* seeds, and any other desirable greenhouse plants, raising cuttings, sowing seeds, or striking cuttings of the commoner sorts for stocks, on which to inarch or graft *Correas*, *Oranges*, *Camellias*, &c.; the grafting of such plants is easily effected in such a sweet moist hotbed, and does away with much of the trouble of inarching. Such a bed will also, be necessary for starting *Cockscombs* and *Balsams*, &c. Strong, early, winter-flowering *PRIMULAS* should be sown the end of this month; and *CINERARIAS*, intended for the same purpose, the month following. **INSECTS**, destroy. **LEAVES AND STEMS**, clean; a little soap and water is a great auxiliary for removing all kinds of filth; syringe with clean water afterwards. **LILIES, JAPAN**, after the stems appear, place in a light, airy situation. **MIGNONETTE**, and tender annuals, sow in slight hotbeds, in pots, turf, &c., to be afterwards hardened off. **SOIL**, prepare, turn, and expose for a general shifting about the end of the month; but do not knock about fresh soil intended for potting, so as to shake the fibre out of it. *PRIMULA SINENSIS* will be greatly benefited by manure-water. The double varieties are well worth a little extra attention, as the flowers stand a long time in a bouquet. **TRAIN** large plants of *PELARGONIUMS*, intended for early flowering; **STOP** those for late summer and autumn. **SCARLET GERANIUMS**, intended for specimens in pots, give good shifts to, and if they can get a little bottom-heat, they will come all the stronger and bloom the finer. The climbers to rafters, after duly pruning them, keeping in mind whether the flowers are produced on young or old wood; train daily those on trellises; and, as the season is now getting on, let neatness, order, and cleanliness, everywhere prevail. **WATERING** will now be more wanted, and a moistish atmosphere in clear weather, to counteract the drying effects of east winds. **SYRINGING** the leaves with tepid water, after a sunny day, is as good for a plant as soap and water is for our own skins. Unless in extreme cases, fire-heat will not be so much wanted. Old *Scarlet Geraniums*, in store, should now be brought into the light, top-dressed, &c.

R. FISB.

ORCHID HOUSE.

AERIDES, and other similar Indian plants, will this month be growing rapidly; give them fresh sphagnum, if in wire baskets; if in wooden ones, renew them, and bring the roots within the baskets amongst the fresh sphagnum. **AIR**, give more abundantly as the days lengthen, and the sun obtains more power. **BLOCKS**.—The plants on these must be syringed twice a-day at least, as they will now be growing rapidly. **BASKETS**.—Dip these in the cistern twice a-week; if very dry, allow them to remain in the water an hour or so, till the hard lumps of peat are thoroughly wetted. **BARKERIAS**, set to work, by giving water freely. **Pot CATASETUMS, CYCNOCHES**, and other similar-habited plants; they will now be growing. **DENDROBES**, see last month. Such as are in flower remove, if possible, to a cooler house; they will then last much longer in bloom; those growing *repat*. **HEAT**, towards the end of the month bring up to the maximum. *Indian House*, 80° to 85° by day, 70° by night. *Mexican House*, 70° to 75° by day, 60° by night. The highest heat to be when the sun shines. **INSECTS**, keep a watchful eye upon, and destroy the moment they are perceived. **MOISTURE IN THE AIR**, keep up a large amount of, by keeping the walks, platforms, and walls frequently flooded. **POTTING**, proceed with, and finish before the end of the month. Now is the time to *increase orchids*, by division or otherwise. **SHADING**.—About the middle of the month place the shades upon the roof, to be ready for use, as the sun will soon be so powerful as to be dangerous. **STANHOPEAS**, now growing, put in fresh compost in large baskets. **STEAM**, where possible, admit amongst the plants. **WATERING AT THE ROOT** must now be regularly given, but care taken that it does not lodge upon the leaves nor in the hollow of the young shoots.

T. APFLEBY.

PLANT STOVE.

ACHIMENES advancing in growth, give water to, but do not flood them in this early season; *repat* such as have filled their pots with roots; pot a batch to succeed the former ones. **AIR**, give now freely in mild weather; take care the apertures for the admission of air are not directly opposite the plants, it is best to come over the pipes or flues, to be heated before it reaches the plants. **AMARYLLIS AULICA**, and varieties, *repat*, and place in heat. **APHELANDRAS**, *repat*. **BASKETS**. Place in these *Eschynanthus*, *Achimenes*, some *Lycopodiums*, and other hanging-down plants; they ornament the stove greatly. There are some baskets made of coloured glass, that are very ornamental objects, filled with proper plants. **CLIMBERS** will now be growing fast, attend to training and thinning shoots; in pots place fresh trellises to, and keep the plants constantly trained around them. **CUTTINGS** continue to put in; pot off such as have rooted. **HEAT**, increase to 70° by day, 60° by night; winter-blooming plants gone out of bloom, cut in severely, and place in a cool house to rest. **IXORAS**, *repat*, stop, and tie out; place them in a frame heated with dung; here they grow rapidly and soon make fine plants. **INSECTS**, continue to watch for and destroy. **POTTING**, finish the spring, by the end of the month. **SYRINGE** freely morning and evening, and keep the paths flooded in sunshine. **WATER** will now be required in large quantities to fast growing plants. Let the walks be frequently washed out, and every yellow leaf removed, every plant neatly tied, and decaying flowers removed as they occur.

T. APFLEBY.

FLORISTS' FLOWERS.

ANEMONES, double, protect from frost. **AURICULAS** and **POLY-ANTHUSES** will now be showing their flower-stems. In this stage they require constant attention. Top-dressing, if not done, must be finished the first week; water regularly in pretty liberal quantities; if allowed to flag now, the blooms will be small. Give plenty of air daily, and shade from bright sun towards the end of the month; cover up securely at night whenever there is the least appearance of frost; sow seed, and pot last year's small seedlings to encourage growth. **CALCEOLARIAS**, *repat*, prick out seedlings, give plenty of air to, and smoke frequently with tobacco. **CARNATIONS** and **PICOTEES**, put into their blooming pots. Search the soil over minutely, to find

wireworms, and destroy them previously to using. Place them when potted upon a bed of coal-ashes, with a convenience of hoops and mats to shelter them from severe weather. Should mildew appear, dust with sulphur; and destroy green fly with tobacco-water or Scotch snuff. **CINERARIAS** finish potting, b.; smoke frequently to destroy every green fly as soon as it appears; water freely, and shade from bright sun as the flowers open. **CHRYSANTHEMUMS** pot off into small pots and *repat*, b., into a size larger. **DALLIAS**, all intended to be potted should now be done; pot off cuttings as soon as rooted, and put in more cuttings if required. Divide the old roots, leaving a bud or two to each division; place each division in a pot, and allow them to grow slowly till planting time; a cold frame, well protected from frost, will be shelter enough for them. **FUCHSIAS**, *repat*; cuttings may yet be put in. Begin to train early, in order to form well-shaped plants. **HYACINTHS**, tie the flower-stems to sticks, to prevent the winds from breaking them off; continue to shelter the bed by hoops and mats. **HOLLYHOCKS**, plant out where they are to bloom; place a mulch of short litter round each plant. **PANSIES**, top-dress; in pots, lay down the shoots round the plant, cut the stems half through to induce roots; shelter from heavy rains and severe frosts. **PELARGONIUMS**, pot young plants; top-dress old ones, and tie out to form large, spreading specimens; smoke frequently, to destroy green fly; when the flower buds appear, give liquid-manure every third time watering. **PINKS**, top-dress, b., if not done last month. **RANUNCULUSES** may yet be planted, b.; shelter the bed from heavy rains, frost, hail, or snow. **TULIPS** will now be growing fast; shelter the young plants from heavy rain, or other severe weather; if rain falls during the day, and a sharp frost intervenes at night, and no protection is given, the young leaves will be much injured. **VEEBENAS**, in pots for exhibition, *repat*, tie out, and nip off the tops of the shoots; shelter both these and those intended to plant out from frost; smoke frequently to keep down green fly, and syringe occasionally with sulphur-water to destroy or prevent the red spider; put in cuttings of scarce sorts; sow seed; look for slugs constantly in the frames under the pots, or any other lurking place, and destroy them. Finish planting **ROSES**, and place those in pots in a warm house, to be coming on for the June or July exhibitions.

T. APFLEBY.

KITCHEN GARDEN.

This is a busy month—every day brings its work; a favourable opportunity should never be lost for doing any particular kind of work; take advantage of open mild weather for every kind of planting; in taking up transplanted plants from nursery beds of any kind, or at any time, always lift them up with some kind of tool or other, as a plant thus transplanted always suffers so much less than a plant drawn from the seed-bed. **ANGELICA**, sow, or plant, e., autumn-sown. **ALEXANDERS**, sow, m. or e. **ASPARAGUS**, sow or plant, e.; and dress off out-door beds; attend to that in forcing, water with liquid-manure once a week. **ARTICHOKES** and **BALM**, plant. **BASIL**, sow a little for early use. **BEANS**, plant; and earth-stir growing crops. **BEEF (Red)**, sow a little for early use. **BORAGE**, sow, and earth-stir autumn-sown, and thin out. **BORECOLE**, sow, m. **BROCOLI**, sow a little of the early kinds, and mark any favourite kinds for seed. **BURNET**, plant or sow. **CABBAGES**.—Any early kinds may be sown, or *Red Dutch*, should plants be wanted. **CAPSICUMS**, sow, to forward in hotbed, b. **CARDOONS**, sow, e., for first crop. **CARRAWAY**, sow. **CARROTS**, sow for early crops; attend to thinning out those in growth, and earth-stirring; sowings of the *Early Horn* may still be made on gentle hotbeds. **CAULIFLOWERS**, plant out the winter-protected; attend to spring-sown, as to airing, pricking-out, and earth-stirring; also assist the early hand-glass crop with soakings of liquid-manure, &c.; and sow in succession, e. **CELERIAC**, sow. **CELERY**, sow main crop, m., and prick out early-sown on gentle hotbed; leave for seed. **CHAMOMILE**, plant. **CHEERVIL**, sow; save seed for autumn-sown. **CHIVES** may be divided, and planted out. **CLARY**, sow, e. **CRESS (American)**, sow. **COMPOSTS**, prepare. **CORIANDER**, sow. **CORN SALAD**, sow. **CUCUMBERS**, ridge out; pot off; or sow in succession; sow also toward the middle of the month, for planting out under the hand-glasses next month; attend to those in bearing; keep up a good moist heat. **DILL**, sow or plant. **EARTH-STIRRING**, attend to in all cases, and often. **FENNEL**, sow or plant. **GARLIC**, finish planting. **HOING**, attend to in dry days. **HOREHOUND**, plant or sow. **HORSE-RADISH**, finish planting. **HYSSOP**, sow, or take up and divide old roots. **JERUSALEM ARTICOKES**, finish planting. **KIDNEY-BEANS**, sow in succession; attend to those in bearing, assist them with liquid-manure. **LEEKS**, sow. **LETTUCES**, sow; prick out; and plant out. **MARIGOLD**, sow. **SWEET OR KNOTTED MARJORAM**, sow a little for early use. **MARJORAM (Common Garden)**, divide and plant out. **MELONS**, sow in succession, and ridge out; attend to earthing-up, training, &c., the early crops. **MINT**, plant. **MUSHROOM-BEDS**, make, and attend to; assist old beds with a little tepid manure water. **MUSTARD** and **CRESS**, sow, once or twice a week. **NASTURTIUMS**, sow, e. **ONIONS**, sow the main crop; plant for seed, b.; also finish planting the *Underground* or *Potato Onion*; also the *Tree Onion*; and look over those in the store. **ORACH**, sow. **PARSLEY**, both kinds, sow. **PARSNIPS**, sow, b. **PEAS**, sow in succession; the beginning of this month, is a good season to sow any of the tall kinds; earth-stir, or earth-up, and attend to sticking, &c. **PENNYROYAL**, plant. **POTATOES**, finish planting, either in hotbed or open quarter. **RADISHES**, sow in succession; attend to thinning out young crops. **RAMPION**, sow. **RAPE**, sow common, and *edible-rooted*, e. **RHUBARB**, sow or plant, b. **ROCHAMBOLE** and **ROSEMARY**, plant. **RUB**, plant. **SAGE**, plant. **SHALLOTS**, finish planting. **SALSIFY** and **SCORZONERA**, sow a little for early use. **SAVOYS**, sow. **SEAKALE**, sow or plant out; attend to early covering-up, to exclude the light from the crowns, for successional and late crops. **SKIRRETS**, sow, e. **SUCCORY**, sow. **SORREL**, plant or sow. **SPINACH**, sow in succession. **TANSY** and **TARRAGON**, plant. **THYME**, sow or plant. **TOMATOS**, sow in hotbed, e. **TURNIPS**, make a small sowing two or three times during the month.

T. WEAVER.

LONDON: Printed by HARRY WOOLDRIDGE, Winchester High-street, in the Parish of Saint Mary Kalendrar; and Published by WILLIAM SOMERVILLE ORB, at the Office, No. 2, Amen Corner, in the Parish of Christ Church, City of London.—February 24th, 1853.

WEEKLY CALENDAR.

M D	W D	MARCH 3—9, 1853.	WEATHER NEAR LONDON IN 1852.				Sun Rises.	Sun Sets.	Moon R. & S.	Moon's Age.	Clock bf. Sun.	Day of Year.
			Barometer.	Thermo.	Wind.	Rain in In.						
3	Th	Large Tortoiseshell; elms.	30.203 — 29.957	45—19	N.E.	—	43 a. 6	42 a. 5	2 41	23	12 9	62
4	F	Small Tortoiseshell; lanes.	30.538 — 30.312	46—15	N.E.	—	41	43	3 50	24	11 56	63
5	S	Speckled Wood (larva).	30.739 — 30.648	45—19	S.E.	—	38	45	4 49	25	11 42	64
6	SUN	4TH, or MIDLENT SUNDAY.	30.740 — 30.699	46—25	N.E.	—	36	47	5 34	26	11 28	65
7	M	Red Chestnut; nettles.	30.665 — 30.579	50—28	N.E.	—	34	48	6 9	27	11 14	66
8	Tu	Blossom Underwing.	30.543 — 30.459	49—31	N.E.	—	32	50	6 35	28	10 59	67
9	W	Dwarf Quaker; oaks.	30.446 — 30.286	52—30	N.E.	—	30	52	sets.	29	10 44	68

METEOROLOGY OF THE WEEK.—At Chiswick, from observations during the last twenty-six years, the average highest and lowest temperatures of these days are 49°1, and 32.8° respectively. The greatest heat, 68°, occurred on the 9th in 1826; and the lowest cold, 13°, on the 5th in 1845. During the period 117 days were fine, and on 65 rain fell.

MR. THWAITE'S BEGONIA.

(*Begonia Thuaitesii*.)

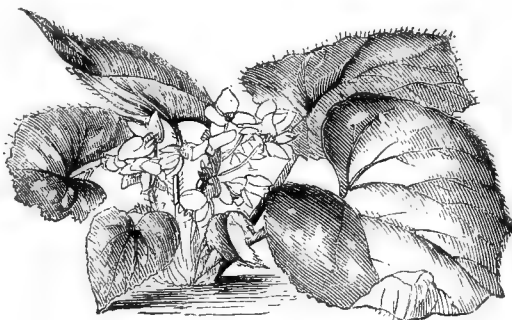

For some years past there has been a regular progressive accession of beautiful species to this fashionable genus, and the one before us may well bear comparison with any species which belongs to the same section of the genus—that with creeping or underground stems. The leaves, which are of medium size, and are borne on comparatively long, hairy foot-stalks, are as handsome as those of any species which has appeared since *hydrocotylifolia* was introduced. The general tint of the leaves is a rich coppery-colour, from a mixture of rich green and reddish-purple, over which are dispersed irregular white blotches, and the underside is purplish-red, after the tint of the same parts in *B. argyrostigma*. The flowers are as large as those of *B. nitida*, and, like them, are white, with the addition of a rich blush suffused over the white ground-colour. It was sent to the Royal Botanic Garden, Kew, by Mr. Thwaites, superintendent of the Botanic Garden at Taradenia, Ceylon, after whom it has been named by Sir W. J. Hooker, who has given a very good figure of it in the last January number of the *Botanical Magazine*. B. J.

Propagation and Culture.—No plants are more readily increased, both by seeds and cuttings, than these Begoniads; and this new and very handsome one from Ceylon is no exception to the rule. The seeds of the whole order, however, are among the smallest we sow; therefore, they require a particular treatment, which is this—Have the seed-pots thoroughly watered before the seeds are sown; a safe

practice not adopted half so much as it deserves. The old rule-of-thumb, is still as perseveringly followed out, by soft-headed sowers, as ever the sucking of thumbs and fingers were in the days of bubbles and soiled pinafores. But, for the twentieth time, let me urge on our readers, at least, to go more scientifically to work, now that they are on the threshold of the great sowing season. To say nothing about fern seeds, or whether they have seeds or no, let us say, that seeds of all the *Rhododendron* and *Azalea* tribes, whether Indian or American, English, Scotch, or Irish; all the *Heaths* and *Heathworts*, in fact; and all the *Lobelials*, with *Calceolaria*, *Begonia*, and all such and similar seeds, ought to have the pots, pans, or boxes, well watered, after being thoroughly well supplied with drainage, and before the seeds are sown. Then such very small seeds ought to be sowed very thinly, and a very small sprinkling of sand to be scattered over the seeds, after that the top of the seed-pot or pots should be darkened with some covering, such as double folds of an old newspaper, or brown paper, or any thing of that sort, and in a few days such seeds will vegetate under a high moist temperature.

Besides all this in general, we know in particular, that every *Begonia* delights in a close, damp atmosphere from the moment of its birth until the end of the growing season. Therefore, pots for *Begonia* seeds should have a layer of clean sand on the top to sow the seeds on, and after the seeds are bedded by another layer of sand, a pane of glass should be placed over the pot to keep in all the damp, in addition to the covering for darkness sake. The creeping underground stems of this, and of most of the kinds, have eyes like those of potatoes, and they may be cut accordingly for propagation. The whole family delight in a rich, light compost, and plenty of pot room. Good strong loam, reduced with equal quantities of leaf mould, peat, and sand, will do to grow this new plant to perfection. It flowered, for the first time in this country, at Kew, last June, and very likely, from the effects of the journey, that was later than will be the general run after the plant is inured to our style of cultivation. At any rate, it could be forced so as to come into flower at the same time as *B. manicata* and *hydrocotylifolia*, and a cross obtained from either of them by its pollen would give as fine plants for spring-flowering as any of the new beautiful crosses which come in in the autumn. The whole tribe are as easy to cross as ridged Cucumbers.

D. BEATON.

ALTHOUGH, practically, it may often amount to the same thing, yet it is not without its use to remember that it is more proper to speak of keeping-in heat than of keeping-out cold. Let not this be thought to sound too much of pedantry, for it cannot be questioned that sound views are most likely to lead to favourable results.

Frost and cold in bodies are merely the consequence of their losing heat from the radiation of that heat into a clear, cool atmosphere. The amount of heat lost will be determined by the season of the year, the brightness of the sky, and the time it remains without clouds. Thus, in a dull, cloudy night in summer, you may search in vain for a drop of dew, because the earth

and its herbage have not become sufficiently cooled to condense the invisible vapour contained by the air in its vicinity, the cloud acting as a protector to the earth, and just sending back about as much heat as it receives. But, during summer, after a clear night, unless the atmosphere is more dry than we have ever found it, you might wash yourself, and so become fair, with pearly drops on any open meadow at early morn. If the sky was very clear, and you went very early for this purpose, even at midsummer, you might have to wait a little until the icy drops were melted. We often retire to rest in spring and autumn, the evening cloudy, dry, and beautifully serene, and when we go out in the

morning, we are surprized to see every twig and leaflet adorned with hoar frost. A clearing of the sky had cooled the points of grass and twigs, and by allowing them to part with their heat, they thus became so many condensers for changing invisible vapour into pearly drops, and the radiation continuing longer, the drops were congealed into flaky ice. When we speak, therefore, of covering-up from frost, we really mean preventing the plant and the earth around it from parting with their heat.

The recent cold weather has brought these matters, just now, before our attention. The *manner* and the *material* best fitted for protecting tender plants become thus matters of importance. Without troubling ourselves with exceptional minutiae, we may set it down as a general applicable rule, *that the less dense the material used, the greater will be the protecting power.* This will appear when we consider, first, that heat radiates from the surface; that the layer immediately beneath then parts with its heat to restore the equilibrium; and that thus the process goes on in a direct line, until, in continued frosts, considerable depth is reached. The mere knowledge of this is of importance, when, in an emergency, we are scarce of litter to throw over our pits and frames in severe weather, or when we wish to use it as economically as possible, as the shaking up and turning the surface of what we have got breaks the line of radiation, and forces the refrigerating or cooling process to commence anew. We have even found, in severe weather, that the breaking of the surface of snow with a rake was of advantage to plants beneath. Where there was great thickness this would scarcely be necessary, as the lightness of the snow and the air enclosed with it would be a sufficient protection to the hardier plants.

Then, again, the same fact will appear, when we consider, that so far as the practical operations of gardening are concerned, the *conducting-of-heat* properties of a body will be in proportion to the *increase in its density.* Hence the different sensations we continue to experience, when, in a cold morning, we take hold, respectively, of a bar of iron, and a rod of wood. The latter, from its weak conducting power at the place we grasp it, soon becomes of the same temperature as the hand; but the bar of iron would continue to conduct heat from the hand, until the hand and the rod became of an equal temperature. Hence the folly of using zinc or galvanized iron, however light and neat, as shutters for plant-houses. Hence, in structures roofed with metal, their great heat in summer, and the increased cold in winter. If we place a plate of metal, and a thickish board of wood, respectively, firmly on the ground, and examine them after a severe frost, we shall find the earth under the first firmly frozen, while under the wood, it will be little more affected than may be accounted for by the loss of heat at the sides by radiation. Hence, too, the reason why frost will penetrate deeper, and heat likewise, into ground that is smooth and hard, than into that which is open, porous, and rough. The reason why we advocate a waterproofed covering for frames, &c., is that the moisture

increases the density of the covering material, and thus furnishes strength to the radiating and conducting-of-heat powers.

Then, keeping in view how a canopy of clouds in a summer's eve prevents the earth being cooled, we are furnished with a key as to the best manner of applying protecting material. Whether the tender plant is in the open air, or under glass, the plant and the glass will be best secured by having an open space between them and the protecting medium. The extent of that space must be regulated rather by financial considerations than by scientific deductions. Three inches will be good; six inches better; and twelve inches superior still. The covering, and the thing protected, just act and react upon each other, then, like the earth and the cloudy sky; nay, more than that, the enclosed air becomes a first-rate protecting medium. We have said that radiation and conduction are regulated by the density of bodies—but what less dense than air? and then, when confined, it is one of the very best non-conductors of heat we possess. Hence, one of our correspondents, some time ago, recommended double sashes for houses and pits, thus getting rid of a mass of littery protecting material. With a space of six inches between the sashes, or even less than that, and the sashes fitted close to isolate the enclosed air, from our own experiments, we should conclude that coverings would very seldom be necessary. But then there would be first expense. Any of our readers, however, who do not use above half their sashes in winter, will find great advantage by making them double, by placing the unused ones over the others in severe weather. Double bell or hand-glasses, will also be of great use for tender plants out-of-doors, such as those that require protection only when young. Single hand-lights of large size, and glazed tight, will also be of great use, as the air within will be confined and still. Whatever is used, whether glass, waterproofed cloth, or even evergreen boughs, let the protecting medium be at a slight *distance* from the plant.

For combining neatness, utility, moderate first expense, and ultimate economy, we recommend, for all glass-covered pits, &c., wood shutters made of half-inch or three-quarter-inch best deal, and painted a stone colour after the wood is thoroughly seasoned. If a temporary frame of wood is fixed to the ends and sides of the sashes, some two inches deep, and the shutters are made to fit close, a body of air will be enclosed that will render other covering unnecessary, while the skeleton frame will save the paint of the sash when sliding the shutter. The same mode may be pursued with asphalte, or with straw, mats, or cloth fastened to a frame, and made waterproof, but none of these modes will so thoroughly combine efficiency, neatness, and ultimate economy. When none of these modes are resorted to, but a clean mat or cloth is placed over the glass, and then, in severe frost, hay and straw are placed above to keep the cold at a distance, both trouble, and the necessary quantity of litter, will be minimised by having a waterproofed cloth or canvass to throw over

all. Not only then will the material beneath be kept light and dry, but all the interstices, and all the tubes of hay and straw, will be filled with enclosed air, and thus become a non-conducting medium. Need we say, that to lessen radiation of heat from such a cover in winter, and to prevent it being half-charred if used for different other purposes in summer, the colour should approach a white rather than a black. Those who have none of these things, but depend upon keeping plants in frames and pits, chiefly by the assistance of litter of various kinds, must, in such weather as we have had recently, see that either they have plenty of it, or turn and shake it frequently. The time, and the circumstances under which plants may be shut up from light, has been lately alluded to. F.

FORSYTH MSS.

(Continued from page 378.)

The two next letters are from Dr. GEORGE YOUNG, Physician to the Royal Hospitals in the West Indies. Of this gentleman we have no other particulars than that the Society for the Encouragement of Arts gave him a gold medal for his cultivation of the Cinnamon in the Island of St. Vincent; and that he died on the 11th of March, 1803, at Hammersmith. He was then in his 76th year. The following letters were addressed by him to Lieutenant-General Melville:—

London, Feb. 8th, 1785.

I am happy to find that the same motives which first induced you to cause a piece of ground to be set aside for a botanic garden at St. Vincent still continue; and I make no doubt but it will still flourish. I am glad to learn that there is a probability of Mr. Anderson's being appointed to the care of it, as I do not know a more proper person for that trust. I have lately sent him out some *Assa foetida* seeds, and shall soon be able to send him a plant of the true Jalap, which drug we are obliged to get from the Spaniards; a plant of *Lechea*, an exceeding fine East India fruit; a plant of the Marking Nut, of which the Chinese make their ink; the Camphor Tree, Scammony Seeds, and other articles. And I assure you, that while I remain about London, I shall make it a point to procure everything, either curious or useful, that is to be got in the Botanic Gardens, or in its environs. I shall likewise make out a list of what things are useful, either in commerce or in medicine, and send it to you, as you may have it in your power to send it to different parts of the world, where your friends may be going, in order to procure those articles.

In the margin of the plan of the botanic garden which I gave you some time ago, you will find the names of the plants that were in the garden when it was first made, but there have been many introduced since; it must, however, be confessed that several have been lost during the time the French were in possession of the island, but they may be easily replaced. What is wanted chiefly, are the spices from the East Indies (which are all in the hands of the Dutch, except the Black Pepper) and drugs. The plants which produce some of our most valuable drugs we know very little about. The Bread fruit would be a valuable acquisition for the West India planters. I am told the trade in walking and other canes is very considerable, insignificant as it may appear at first sight. I have often wished to have got the Cochineal Insect introduced into the West India Islands; there are several plants of the *Opuntium maximum*, on which they feed, in the Botanic Garden in St. Vincent; and I have seen some of them in Grenada and Barbadoes; this last island is peculiarly adapted to the culture of Cochineal, as it is a dry soil, and has a great number of poor white people in it. The *Opuntium maximum* is easily pro-

pagated, as the least bit cut from the plant and stuck in the ground takes root immediately.

It is amazing what a foundation for commerce the introduction of a new plant may lay; instances of which are the Sugar Cane, Coffee, Cacao, Indigo, and Rice. About fifteen or sixteen years ago, I obtained a single root of the Curcuma (Turmeric), which multiplied to such a degree that I was enabled to spare a good many roots of it to a Mr. Robley, at Tobago, who, before the island was taken, used to send to England several thousand weight of it annually. Some persons, at Barbadoes, had roots from the Botanic Garden, and I find they send some hundreds of it home likewise.

After you left the West Indies, I got, by accident, a plant of the true East India Mangoe, from an officer, who was returning from thence to St. Kitts; and Dr. Jackson got another, which both grew; and now there are above fifty plants in St. Vincent, so that, I think, we have secured that valuable plant, of which I brought some home with me for his Majesty's Garden at Kew. The Tallow trees, of which the Chinese make their candles, thrive very much; there are above fifty in the garden above twenty or twenty-five feet in height, which, in July last, were loaded with green fruit. The tallow envelopes the seeds, and, I suppose, is separated in the same way as the Myrtle wax is done in N. America, viz., by throwing the seeds into boiling water, and so skimming off the tallow.

London, 16th February, 1785.

As you are sometimes with the Secretary at War, and that I hear there are some regiments going out to the West Indies, I should be very glad if you would endeavour to procure an order for the commanding officers of them to send a roll to the War Office, specifying the age, complexion, size in feet and inches, former trade or way of life, colour of hair, eyes, &c., of the men. The only roll of that kind I could ever get was of the 32nd regiment. I found that, in the first four years of their stay in the West Indies, those of a certain complexion died at the rate of two to one of another complexion; and other curious particulars were observed, which had not been expected. If a roll, such as the above, were to be had here, one could make observations from the returns of the dead. Were private application to be made to the commanding officers, very probably they would agree to this; but, perhaps, never think more about it, as I have experienced several times, unless there is an order from authority. On this subject I must say that I think it a great pity that so many fine children should be permitted to go to certain destruction in the West Indies; almost all of three years of age, and under, constantly die, and those from three to seven perhaps at the rate of one-half or two-thirds. Is there no workhouse or hospital whither they might be sent, and so a number of lives be saved to the community? As to the women that go with the troops, they are allowed on the notion of their being useful to them in washing, nursing the sick, &c., the contrary of all which I can safely affirm; for they either soon get sick themselves, and so add to the calamity, or they keep sutling huts and dram shops, where they poison the men with new rum, and other bad liquors, and are the cause of almost all the irregularities that happen in a garrison. To prevent any discontents amongst the troops, if the women were all refused, perhaps it might be best to permit a certain proportion to go out with each company.

COVENT GARDEN.

As was to have been expected, the supplies of all kinds have fallen very short since the severe frosts set in, and the consequence is, all produce has materially risen in price. It has been hardly possible for the market-gardeners to find even what they have managed to bring to market, where, in some instances, the grounds have been subjected to a frost varying from 10° to 12°.

As an instance of the sudden and great rise, we may mention *Greens*, which could not be had under from 4s. to

5s. per dozen bunches, whilst last week the same article, and of same quality, might be had in abundance at from 1s. to 2s. We have observed one or two parcels of genuine *Early Potatoes*—not the pale-faced *sans robes* sort we spoke of a week or two ago, but real *Early Frames*, with all their unwashed exterior about them. These, however, are not general. We have also noticed a few forced *Strawberries* of the Keen's Seedling variety. These, too, are mere curiosities, and, to all appearance, are more for show than use, for nobody seems to buy them. We are wearying for the season when we shall see them *au naturelle*, and have an opportunity of dis-canting on the numerous varieties which will then be presented. At present we have no exciting subjects; nothing to create a warm, glowing, interest. We refrain from giving a dissertation on Oranges, for that nobody would care about; but if such were required we could do even that. Chesnuts are a dry subject, and so are Walnuts. The only genuine feast at present is that supplied by the flowers and bouquets, which, *en passant*, if time permit, we shall treat of as we promised.

As we have already said, VEGETABLES have advanced much in price. *Savoys* have made as high as 2s. per dozen; and, indeed, almost everything has been from one-fourth to double the quotations of last week.

Notwithstanding the frost, the FLOWERS have been abundant. They consist chiefly of *Camellias*, *Cinerarias*, *Primroses*, *Geraniums*, *Azaleas*, *Hyacinths*, *Tulips*, *Heaths*, *Lily of the Valley*, and *Violets*. H.

GOSSIP.

It is satisfactory to observe any expression of the public disapprobation of the trickery to which some *Exhibitors of Flowers* condescend. This trickery has condescended to such practical falsehood as attaching extra pips to a truss of *Auriculas*; and the trimming off, and the twisting into form of petals in *Picotees* and other flowers of that genus, are practices of occurrence at every Floral Exhibition. That these are reprehensible practices needs no argument, for the skill which the prizes are designed to reward is the gardening or cultural skill which can produce the most excellent flower by the plants own healthful and vigorous growth. To give the prize to a man who has trimmed his blooms into the best form, is doing little more than rewarding the best artificial flower-maker. We have been led to these observations from noticing that at an *Extra Grand Carnation, Picotee, and Hollyhock Competition*, to take place at Glasgow on the 17th of August, one gentleman, William Church, jun., Esq., has thus liberally demonstrated his reprehension of the artificial system:—

TO PRACTICAL GARDENERS AND AMATEURS.

For six varieties named *Picotees*, to be exhibited in 10-inch pots, in which they must have been grown for at least three months. The blooms to be shown in their natural state, without trimming or dressing of any kind. A declaration must be given to the effect that the blooms are exhibited as required. The object of this Prize is to promote the growth and improvement of varieties *naturally* fit for exhibition;

or, in other words, such as do not require to be previously manufactured. First Prize, £2 2s.; Second Prize, £1 1s.

Next we have to notice, as will be seen by a reference to our advertisements, that *The Doncaster Poultry Exhibition* this year is to be limited to *two* days. This Society, therefore, has the merit of setting the example in adopting this most desirable reformation; and we quite agree with its Secretary in his opinion, not only that "it is 'a consummation most devoutly to be wished,'" but that "it will assuredly have to be the case in other and, at present, larger exhibitions."

Our correspondent, "Upwards and Onwards," writes to us—

"As a further proof of the undomesticated nature of the *Silver Pheasant*—that the 'erratic fellow' mentioned in a previous article of mine, after three years almost uninterrupted sojourn, suddenly took it into his head to decamp, and provide himself fresh quarters in an orchard about a quarter-of-a-mile distant. Whether from biped or quadruped 'worrying,' I cannot take upon me to say; suffice it, the poor fellow was brought back in such sorry plight, that he soon after died in the lodge-keeper's arms. I miss his formal and meditative going to bed in the branches of an old Cedar of Libanus every evening very much."

On Thursday, a deputation from the Council of the *Bath and West of England Agricultural Society* met by appointment, at the Plymouth Guildhall, gentlemen, selected at the last meeting of the local Committee, to confer with them on several matters connected with the Exhibition, but particularly with regard to the selection of the spot for the show of cattle, implements, &c. The Secretary stated that he had received official communications from the Great Western, the Bristol and Exeter, and the South Devon Railway Companies, stating that they would convey all cattle to and from the Exhibition free of charge, and all implements at half the usual cost, provided the cattle, implements, &c., were sent direct, without the intervention of any public carriers. This announcement of the liberality of the respective companies also gave much satisfaction. It was further stated that the Poultry Show would form an integral part of the general exhibition, and would be held in the same inclosure. With regard to a Flower Show in connection with the proceedings, there was a difference of opinion, some gentlemen imagining that it would be injurious to the interests of the Society rather than beneficial, as it might attract attention from the real object of the meeting; the subject, however, will be decided by the Council. The selection of the site was then brought into consideration, and after hearing all that could be advanced, the deputation, after having viewed both spots, at Mutley and Pennycomequick, selected the site at the latter place. The Exhibition will take place on Wednesday, Thursday, and Friday, the 8th, 9th, and 10th of June, and amongst the prizes to be offered are the following:—

	£	s.	d.
For Devon Cattle, prizes amounting to.....	77	0	0
For South Devon or South Hams Cattle, ditto....	50	0	0
For Cattle of any other breed	77	0	0
For Long-woolled Sheep	40	0	0
For South Down Sheep	20	0	0
For Dorset Sheep.....	32	0	0
For Mountain Sheep	12	0	0
For Pigs, large breed	15	0	0

For Pigs, small breed	£15	0	0
For Horses	45	0	0
		383	0
For Poultry	77	10	0
For Pigeons	8	0	0
		85	10
For Implements used in the Preparation of Ground	28	0	0
" Cultivation of Crops	29	0	0
" Harvest Crops and preparing for Market.....	57	0	0
" Preparation of Food for Stock	23	0	0
" Miscellaneous	10	0	0
For Collections of Implements	23	0	0
For Plans and Models	10	0	0
For New and Improved Implements ..	10	0	0
		190	0
		£658	10

WHAT SHALL WE DO TO SECURE A CROP OF FRUIT?

WHAT can be done, and what ought not to be done? are important questions to others besides gardeners. That we have passed, or nearly so, an extraordinary winter, will be at once admitted; and, as in philosophical matters, effect must follow cause, so it will be found that such irregularities must produce a corresponding effect on our fruits. It may be fairly expected that where trees are young, and soils rich and favourable to a late root-action, trees will start into growth with a spongy kind of robustness, much at variance with the habit that produces plenty of good fruit. And why? Simply because, under the circumstances, there would be a much later and more copious absorption, quite averse to that degree of solidity in the wood, which gardeners term ripeness, and without which a high amount of productiveness cannot be obtained.

I have little doubt that numberless young trees situated thus have had root-fibres in activity through much of the winter; indeed, in moving a Peach-tree lately, I was rather astonished to find evident signs of the active principle in the finer fibres; and in removing surface-soil to top-dress bush-fruit—an annual practice with me—I found a regular net-work of "sponglets" encasing the soil at about two inches below the surface; thus evincing, in a threefold way, their sensibility to the coaxing conditions of a soft and mild winter, their partiality to atmospheric influences, and their fondness for nestling their finer fibres in a generous surface compost.

If our remarks as to luxuriant trees be right, they would seem to urge the importance of a little extra root-pruning, if injudiciously omitted in October. There are those who talk about lifting or transplanting instead, as being a much more fashionable procedure, and who say that it is a very different thing in principle from root-pruning. These are *nice distinctions* indeed: "tweedledum and tweedledee." If the fate of our millions of fruit-trees in Great Britain depended on such niceties, involving so much labour and, of course, expense; it would be time, I think, to leave the culture of fruits to our foreign friends, and to rely only on importations.

When a tree is root-pruned, many roots and fibres are ruptured by the spade, the points of which are knifed after by good root-pruners; and what but the same occurs when a tree is taken up and replanted? excepting, that in this over-officious tampering a considerable amount of galling takes place on the tender skin of the roots, the mischief of which it is not easy to calculate when the trees are any size or age. This fact seems to have been overlooked. To transplant a tree through necessity and of choice are two very different

affairs. If a tree is in a badly-constituted soil, or the soil exhausted; if the soil be too wet, or the tree too fond of producing suckers, transplanting, or what our northern brethren call "lifting," may be resorted to very fairly. I am as old a root-pruner as any in England, the first, I believe, to insist on the propriety of the practice, and I have root-pruned in many hundreds of cases, but I have never yet seen any evil consequences worth noticing. The chief thing has been a liability to fungi, or scale, on the bark for one summer, or until the active growth again commences. But this is soon got over, and is just what occurs through temporary poverty in some animals: they become infested with vermin for awhile, which a generous diet, and a good currying or two, will soon disperse.

This, however, is not the chief matter I wish to press. I must now refer to protection and retardation. Some will think it strange that two principles, which appear in antagonism at first sight, should be brought into action by the same medium; but so it is, and no marvel. It is an old saying, that "what will keep out heat will keep out cold." When canvass, or other moveable covering, is placed before the trees during sunshine, it is a retarder; and when placed before them on a very severe night, it is a protector.

I would here wish to observe, that it is worth while considering what character a material for protection ought to possess, and what is the gravest fault chargeable on coverings; for, although I am assured it is the *abuse*, and not the *proper use*, which lies at the foot of this, yet it will be well to provide for the worst. The most serious charge, we believe, is that termed "drawing," a gardening technicality with which most of our readers are by this time acquainted. Drawing is a weakening; inducing a weakness; or, in other words, a tenderness in the unfolding buds. Everybody who has gardened a little with a common cucumber frame knows well, that any choice pets which have been coddled in such a structure during dark weather acquire a lengthened, weakened character, and must be removed to the open air by degrees, and with much caution. "Drawing," then, in fruit-buds, is similar in a degree. To obtain a material which will bear little *neglects* occasionally is the desideratum, it would appear; for although it is no part of the duty of a public adviser to advocate neglects, it is one to provide for them when they occur.

I have observed, in former papers, that I have for more than twenty years used canvass, a material much like what is called "cheese-cloth," but manufactured specially (I believe) for protecting purposes. This article has been patronised by Sir Joseph Paxton, inasmuch as Mr. Hulme, who has furnished us, has told me of considerable demands from Chatsworth. Be that as it may, it is a good thing until we meet with a cheaper article, for I have little fault to find with it on principle. Now this canvass may be had so *close* in texture that the sun's rays may be entirely subdued, and it may be had so *open*, that distinct gleams in sunshine may penetrate at regular intervals; and apertures that will admit distinct gleams of the sun, will, of course, permit a very free circulation of air.

I have now (after these preliminaries) to advise the use of a well-twisted, open-meshed canvass, or other such material in preference to one that is close-meshed. The difference is considerable, as I have proved. It must be remembered, that our late spring frosts, as far as the matter of frost is concerned, act much more in a perpendicular direction than horizontally; and, moreover, what comes sideways, although frost and a south-east wind combined, may, as far as my experience goes, be left out of the question for practical purposes.

With good broad copings, and a canvass of the above description, properly used, I will engage to secure a crop of fruit six years out of seven. I had almost said

one more. But there is another point.—There is no drawing here; at least, if common sense be applied in the affair.

If any one will place himself behind two distinct specimen pieces, on a sunny and airy day, the one distinct and open-meshed, and the other close, ill-twisted, and confused, he will soon perceive the difference in the interior areas; the one lively, and admitting a real sunshine at intervals; the other of a dormant and dull character, damp, stagnant, and chilly.

And this applies to all coverings of whatever kind; they ought to be permeable (at somewhat regular intervals) by the sun's rays, and by a circulation of air. If the light admitted is flickering in character, so much the better, and almost any material not too closely fastened will produce this; even canvass, although fastened on poles, by its undulatory motion during wind, produces a flickering or shifting light.

Most of the preceding remarks are applicable, in the main, to walls or other fences. I must add a few observations on other coverings. Where there are perpendicular trellises, care should be taken to place a good covering on the top rail. Spruce fir branches, hung sloping outwards and downwards, to throw off the rain, would be very good. And why not have moveable copings to these trellises? Surely, if it is worth the expense to have such trellises, it is worth a few shillings more to carry out the objects for which they were made. Such might be a naked rod above the trellis, with a coping something in the form of a common water-spout on the eaves of buildings, but placed invertedly on this rod; it should project nine inches on either side.

This, with fir boughs stuck in sideways the height of the trellis, and remaining there day and night until the blossom is set, would, I am of opinion, be found excellent. Where such trellises run east and west, the boughs might be tolerably thick on the north side, and thin on the south; and where they run north and south, the thickest on the east side. Placed so as to admit a liberal amount of the sun's rays, I have no doubt they will prove of much value, and, when done with in May, will be excellent fire-wood. There are hundreds of places in the country where such plantation thinnings are given away, the owners never thinking of putting them to any use.

Table trellises, too; those who desire to go a-head, and fear not a little outlay, might be covered easily nightly with canvass on a roller, the latter working in grooves on an iron railway suspended above the table. A stroke or two with the hand at night would soon discharge the roller along the rail, and it would be as easily returned the following morning. I proposed, if I remember right, a plan of this kind some sixteen years ago, in "Loudon's Magazine;" and had I possessed sufficient capital at the time, I would have taken a few acres of good pear soil, in some central district, and laid it all down in table trellises on this principle. The tables should have been in parallel lines, with only a yard or so between them, so that a square of this kind would have been like a little town with parallel streets; and the only thing requisite to complete the establishment would be an outer wall some fifteen feet in height, taking care that this became a source of high profit, as well as protection.

Ordinary espaliers, also; why not some attempts to ward off our awkward and ill-timed spring frosts, which surely no man would desire to see encrusting his April blossoms. Here, again, the spruce branches are of much use; at least, so I have found them, provided they are stuck in judiciously, not too thickly, and a portion of them made to rise above the blossoming portions, in order to ward off perpendicular frosts; in addition, too, huge boughs, if at hand, to ward off cutting winds. The

fronds of the common fern, as is well known, are very good things, but the spruce is better, as applied with less labour, and possessing the desirable quality of shedding its foliage progressively as the season advances.

Fixed protections, of course, do not present the advantages of those which are moveable, as canvass, bunting, &c.; for we cannot expect that the ordinary gardener can—with his multifarious spring labours—be daily removing branches for the sake of the sun's rays. Therefore it is plain that it is the best policy to take care that the branches used for protection be not so close as fairly to obstruct the rays; but that rather an extra allowance surmount the fruit-bearing portions of the tree; for, after all, the greatest damage will ensue, as before observed, in a perpendicular direction. And now, let us advise those who possess moveable coverings to be attentive in uncovering their trees to ordinary weather, such as is termed very cold; merely covering against frosts and cutting winds; in other words, beware of the evil termed "drawing," before explained. Nevertheless, as soon as the real blossom begins to unfold, by all means let the covering down every evening, and, indeed, use the same caution as a market-gardener does over his early Radish-beds—daily attention to putting them to bed warm, as it is termed, or, in other words, covering-up whilst the sun is yet shining.

This spring will require extra caution, and one point amongst the rest is, that early and attentive hand-picking will be advisable the moment the setting is accomplished. "There are no gains without pains."

ROBERT ERRINGTON.

MEETING OF THE LONDON HORTICULTURAL SOCIETY.—FEBRUARY 15TH, 1853.

THE weather-glasses and thermometers showed this to be the coldest day experienced round London this winter; and, under glass, all sorts of plants are said to be soft and tender, and therefore more liable to be pinched with cold frosty winds than usual. This is a conclusive reason why the exhibition tables were not loaded to-day as we have had them hitherto all the winter. The company, too, were not nearly so numerous as at the last few meetings, but there was a greater portion of ladies, and the lecture was as long as usual, and as interesting, without any appearance of "spinning" against time; so that we all passed a very agreeable hour.

The next meeting of the Society will be on the 1st of March, and the time of meeting 3 P.M. On the following day, the 2nd of March, there will be a very interesting exhibition at the garden of the Society; Mr. McGlashen, of Edinburgh, who has invented a machine for transplanting trees and shrubs, is to show off the wonderful appetite of this new gardener; and all the members of the Society (between 4000 and 5000) may go there free of admission fees, and I think they may introduce their friends also.

The two lions of the meeting were perfectly new and very handsome winter-flowering plants, sent by Mr. Glendinning—*Rogiera amena* and *Geissomeria aurantiaca*. This last has the handsomest leaves of all the Acanthads, the order to which it belongs. They put you in mind of the beautiful leaves of *Barringtonia speciosa*, or some very healthy, young, and full-sized leaves of *Magnolia grandiflora*; and the flowers come at the top exactly as in *Aphelandra*, and very much in that way. Without looking at the private mark, no one could tell it from a handsome *Aphelandra*; and by all accounts, and also from the look of the plant, it will require the very same kind of treatment as *Aphelandra cristata*. It seems, likewise, to be as easy to manage.

All the *Rogieras* are very showy plants, and this

amœna has the flowers in heads very much like *Pentas carnea*, or between that and the head of an *Ixora*. They are also very free bloomers, and the flowers hold on a long time; the whole family are easy to grow, and the plants are highly deserving of extended cultivation.*

There were cut branches of *Acacia dealbata*, or *affinis*, or the Green Wattle Mimosa of the Australian diggings, loaded with golden flowers; from a tree twenty feet high, which has stood out in the open air at Taunton for many years, and is one of the fastest growing trees of the whole order to which they belong. This handsome tree is often cut down to the ground in other places by severe winters; but then it is so very easy to increase it from seeds, or cuttings, that the loss need hardly be felt. I once had a lot of seedlings of it, and planted one of them in a new, deep, rich bed, in a rock garden, and in three years it was eighteen feet high, and was loaded with flowers all the winter; but I could do no good with it, nor with any of the small-leaved section of the tribe, on chalky soil; while *Acacia verticillata*, and its kindred, did better on chalk than I ever saw them on other soils. The *dealbata* and *verticillata* breeds would always endure ten or twelve degrees of frost without flinching.

There were two specimens of other *Acacias*, *linifolia* and *ixyophylla*, fine bushy plants, in full bloom, from the garden of the Society; and some *Camellias*, which were terribly nipped by the cold winds on the journey, although they travelled in a close-covered van; also fine plants of *Echeveria rosea* and *retusa*. The *rosea* has the habit of the old *Crassula* (*Kalosanthes*) *coccinea*, and, like it, blooms at the end of the shoots in conical heads of deep rosy flowers. The succulent leaves are also of a reddish tint in winter. This *Echeveria* might be grown into a large compact specimen, as they do the scarlet *Crassula* for the June and July exhibitions; and there is not a plant in our Dictionary that would suffer less from a month's confinement in a drawing-room. Indeed, all the *Echeverias* are eminently useful for room plants in winter, and they are as hardy and as easy to grow and keep as a common Cactus.

The Society has a very good variety of *Franciscea hydrangeaeformis*, and its merit, explained to us in the lecture, is that it does not die off at the ends of the leaves, as all the others almost invariably do, under all kinds of treatment. I am rather surprised to see the Society exhibiting plants, like the present, under false names, when they offer medals for the correct naming of plants. I have shown long since, in THE COTTAGE GARDENER, that there is no such name as *Franciscea* by law established, and the same is pointed out in the "Vegetable Kingdom," our best authority in this country.

The sweet-scented *Rhynchospermum jasminoides*, from China, was in the Society's group, trained round sticks in a pot, but it was so frost-bitten that strangers could not see the value of it at all. We have had it often talked about in these pages as a good plant to train out against a wall, where it will flower from June to August. In-doors it blooms in the spring; it will also stand the heat of a stove, and the small white flowers are as sweet as anything.

There was a fine specimen of *Epacris onosmaeflora* in the Society's collection, with some other varieties of these useful plants; and a large bunch of cut flowers from the Hon. Mr. Strangways, among which were

some fine hardy specimens of *Helleborus*, quite as good and more showy than even our old Christmas Rose (*Helleborus niger*), *H. olympicum*, is a nice blush flower, which any one may grow in a common border; also a Russian species, with whitish-yellow flowers, very pretty; it is called *Helleborus Chamschapticum*; and some others, all of which are winter or spring-flowering hardy herbaceous plants that every one ought to grow who has a garden. Very few gardeners pronounce the name *Helleborus* right; they put the accent on the *o*, instead of the last *e*.

Euphorbia meloformis was among the cut flowers. A Cape plant, which, in Dorsetshire, stands out the winter close by the sea-side, forming a handsome evergreen bush, but the flowers are not of much account.

Among *Fruits*, there was a very handsome *Providence Pine Apple*, from Mr. Dodds, gardener to Colonel Baker, of Salebury. It weighed full nine pounds, and was very regular in the pips. There were three beautiful bunches of *Muscat of Alexandria Grapes*, that would keep till April, with ordinary justice; and Mr. Snow, gardener to Earl de Grey, sent a dish of six *Dessert Pears*, in excellent keeping; and we were told that all these kind of pears were over some time since in the London fruit-rooms.

From Her Majesty's garden at Windsor we had a bundle of 100 *Asparagus*, weighing twelve pounds: the finest that ever was seen. They were from beds that are heated by hot-water pipes; the plants planted out as in an open air bed, and each bed is forced every other year, and of all the forcing we ever heard of, this is the most successful; and, what is better than all, everybody seems delighted to hear that the Queen wins a prize; and, when the meeting is over, they all flock to have a sight of Her Majesty's produce.

There is another feature at these meetings that I never told of yet; people from all parts of the country bring up pieces of new or very rare plants to get the right names of them, and if there is no nurseryman or gardener there who happens to know such things, the lecturer is appealed to without ceremony, and the thing is soon settled. On this occasion, a friend of mine had a handful of *Stauntonia latifolia*, an Asiatic hardy evergreen climber, which grows as fast as a Hop. This new plant has not been mentioned in THE COTTAGE GARDENER yet, but I had it in my eye for sometime, from seeing it at Mr. Jackson's nursery, and from being everybody's plant. It is as useful as the Ivy for covering trees; and it will cover as much in four years as the Ivy does in ten. The green is as deep and rich as that of Ivy; but *Stauntonia* does not cling to anything, like the Ivy and Virginian Creeper, nor with clasps like the Grape Vine and Passion Flower. It must be led for awhile at first, and as it gets strong it will twine itself to any support. The whole plant is quite smooth; the leaves without stipules. They come in threes, like some huge *Kennedya*, and each of them is of the size of a Sweet Bay leaf, and deep green all the year round. The flowers are not much better than those of the Ivy. The fruit is a kind of longish berry, not good to eat, but harmless. It seems to be as hardy as we want any plant to be for this climate. Whoever wants a handsome, hardy, evergreen, fast-growing, strong climber, this is one of the very best and newest of that class.

The next to it, and belonging to the same group, is *Lardizabala tritermata*, a Chilian climber, which is not, perhaps, quite so hardy as *Stauntonia latifolia*. The genus was named by Decandolle, and, I believe, after Sir George Staunton. The natural order to which it belongs is called *Lardizabalads*, a hard name given by *Decaisne*, in 1837, and since adopted by *Eudlicher*, *Lindley*, and other first-rate dealers in hard names. *Kadsurads* and *Menispermads* are very nearly related to these *Lardizabalads*.

* The *Rogiera amœna* can scarcely be distinguished from *R. Me-neckma*, a drawing of which is in the second volume of *Paston's Flower Garden*. They are both natives of Guatemala, and both are described by M. Planchon in his account of the genus in the *Flore de Serres*. A drawing of *Rogiera amœna* is in the first volume of *Paston's Flower Garden*, and it will be found described in *The Cottage Gardener's Dictionary* as *Rondeletia thyrsoides*, from which genus, with some other species, it is now separated. The name of the new genus is in honour of M. Rogier, one of the Belgian statesmen, who is a patron of gardening and farming.—ED. C. G.

According to Dr. Siebold, the country people of Japan eat the fruit of another *Stauntonia*, called *hexaphylla*, as ours do the bramble-berries, on account of their sweetish watery taste, and the juice is one of their domestic medicines for sore eyes. I never saw this plant till the winter of 1851 and 1852, when I found a large old plant of it growing over every thing that was near it, in one of the coldest places in Surrey, Kingston Hill, where Mr. Jackson has his principal stock of the more hardy trees and shrubs. This plant was one of the first seedlings which Mr. Jackson reared. There is a nice plant of it in one of the college gardens at Oxford, and I saw two plants of it set against two large handsome ash trees in the new garden of Mr. Sturgeon, the great breeder of Shanghai Fowls, whose celebrated stock I had a longing desire to see, and, if I am not mistaken, his new garden will soon be as unique and celebrated as his "Imperial Buffs" and "Cinnamons." At all events, he has been taking a leaf or two out of our COTTAGE GARDENER, for I saw that these *Stauntonias* were planted on the tar-barrel-system, the only mode by which we can get climbers established against full grown trees, or in front of plantations.

To make the best of a tree, or ruin, covered with ivy, or any evergreen climber, such as the one now under review, there ought to be a *Clematis montana* and a Virginian creeper (*Ampelopsis hederacea*) planted, to run up over the Ivy, but not to allow them to cover it all over. The Clematis, after reaching the top, would hang down in long wreaths of snow-white blossom to the ground in the month of May, and in the autumn the purplish-scarlet tinge from the fading leaves of the "creeper" would be no less beautiful, nor less in contrast to the deep green below it.

But to return to the meeting of the Society. In the absence of winter Lettuce, except two samples of everyday-looks, we had a *Lettuce bell-glass* from Paris, one of the very best things of the kind I ever saw; it was about eighteen inches across the opening, and as much in height, and the exact shape of a bell, with the glass quite thick, and bright enough for a cottage window. These bell-glasses are in use by the thousands all round Paris, where they cost only 7½d. a piece, and there is no reason why we should not have them here just as cheap and good, only that they are not dear enough to render them fashionable.

There was another contrivance, by Mr. Cuthill, for heating small greenhouses and other rooms by means of gas. This may be described as like a system of hot-water pipes, two inches in diameter, running, not from a boiler, as in the hot-water-plan, but from an iron night-cap, for that is exactly the shape of the thing. A hundred jets of gas, or more, or less of them, might be arranged in circles, one within the other, so as to get a great blaze in a very small compass; then, by placing the iron night-cap over the burners, the heat is carried away along the pipes through a socket-joint at the top of the cap, where the top-knot ought to be. There is a door at the bottom of this iron cap by which air is admitted, or kept out, at the will of the attendant. It was told us, that all the contrivances that have been hitherto tried for heating greenhouses with gas failed from the impossibility of securing the joints, so as to be gas-proof, but Mr. Cuthill, the inventor of this plan, says a composition of white and red lead will effectually prevent the escape of gas at the joints of this apparatus. I never had any experience in this way of heating, but I can see quite clearly, that if there is no other objection to heating by gas than that of its escaping by the joints, and so contaminating or poisoning the air for plants, that can be as effectually prevented as leakage by hot-water, and when a system of iron-pipes for heating a building is on the hermetically sealed principle like this, the heat given off, or radiating from the iron surface, is equally

safe for plants, whether the heat be circulated by water, oil, gas, or any other medium.* D. BEATON.

PRESERVATIVE WALLS.

(Continued from page 385.)

LIST OF SUITABLE PLANTS.

CEANOTHUS.—A large genus of very handsome, generally blue-flowering, shrubs. Though the flowers are individually small, yet they are produced in such profusion that they are very showy in a mass. Mr. Hartweg found several species in California, and these have proved quite hardy against walls. There are some fine specimens of these growing in the Chiswick Gardens, on the walls there, and some even in the open borders. I saw, also, some fine specimens growing against an east wall in the gardens belonging to A. F. Slade, Esq., at Kinmell House, near North Cray, in Kent. There they had reached the top of the wall, and had never had any protection excepting what the wall afforded. This proves that they are very suitable for preservative walls, whether they are protected or not. I shall select a few of the best, including some that are rather tender, and will require protection in the northern parts of the empire.

C. AZUREUS.—This is the old well-known species, a native of Mexico, requiring a slight protection.

C. CUNEATUS, or wedge-shaped, referring to the leaves.—Blue-flowered; native of California.

C. INTEGERRIMA (Intire-leaved).—A handsome species, with bright foliage, and blue flowers, from California.

C. NEPAULENSIS.—This has yellow flowers, and requires protection.

C. PAPILLOSUS (Pimpled).—The leaves are covered with warty pimples. The heads of flowers have long foot-stalks, which renders them more conspicuous. I consider this the finest species of the whole genus. It is a native of California, with pale blue flowers.

C. RIGIDUS (Stiff).—Though of a rigid habit, this species sends forth long straight shoots, which may be easily trained against the wall. The flowers are nearly sessile—that is, without stalks—and are produced thickly all over the young branches. It is a native of California, and very handsome when in bloom.

C. SANGUINEA (Crimson-stalked).—This is from the banks of the Missouri, and has white flowers. Its chief beauty consists in its beautifully-coloured young shoots.

CORONILLA GLAUCA (Milky-green).—This old inhabitant of our greenhouses is very suitable to plant against a wall of this description. When planted out it grows freely, and flowers abundantly through the winter. There is a variety with variegated leaves, which is curious, and well worthy of cultivation even in pots. Glass covering, without heat, will be sufficient protection.

CORREA ALBA and **SPECIOSA** are hardy enough to grow against a preservative wall, if covered with glass, even without heat.

CYTISUS FILIPES (Thread-stemmed).—An elegant plant, with numerous white flowers. Requires protection from frost.

DAPHNE INDICA RUBRA and **ALBA** are both evergreen shrubs, sufficiently hardy for the preservative. The flowers have a strong agreeable perfume, scenting the air of a whole house when in blossom. They flower in winter, which renders them particularly desirable. Requires the protection of glass and a heated wall. Soil, peat and loam in equal parts.

DIPLOCLADUS PUNICEUS (Scarlet).—A handsome free-flowering shrub, requiring a slight protection.

* We have received a plan from some gentlemen at Tiverton, precisely similar to the above. It has been some time in operation, and answers perfectly. We shall publish a drawing of it next week.—ED. C. G.

DRYANDRA.—See *Banksia*. The same remarks on the fitness of *Banksias* for a preservative wall applies to this allied genus. Any of the species are desirable for the purpose, but the best are *D. floribunda*, *D. formosa*, and *D. tenuifolia*.

EDWARDSIA GRANDIFLORA, a fine shrub from New Zealand, with large yellow flowers.

E. MICROPHYLLA (Small-leaved).—Both these plants are sufficiently hardy to grow against a plant wall, without heat, if sheltered in severe winters by a covering of glass, or even if covered with a common garden mat. In the south they do not require even that protection.

ENKYANTHUS QUINQUEFLORUS and **E. RETICULATUS**.—Two fine evergreen shrubs, with bunches of pinkish flowers, something like the flowers of an *Arbutus*. In pots they grow straggling and unsightly, but planted against a wall, and protected from severe frost, they form handsome objects.

ERIOBOTRYA JAPONICA (Loquat Tree).—This tree has been considered to require the greenhouse to cultivate it in. It is a fruit tree, and the fruit is much esteemed by the Japanese. Planted against a wall it is sufficiently hardy to bear our ordinary winters. I saw it in fruit in the gardens at Welbeck, two years ago, growing in a cold greenhouse without heat. I also have observed a tree of it growing in the open border in a garden at Chapelton, near Leeds, in Yorkshire, where it had existed since the time that garden was owned by the late R. A. Salisbury, Esq., though it had never fruited. Planted in a conservatory it would thrive well, and its noble leaves and fine appearance would be very attractive. It would most likely fruit, there, especially if it was grafted upon the Quince stock.

ERYTHRINA CRISTA-GALLI (Cock's-comb E.).—Though not strictly a plant for a wall, on account of its losing its shoots annually, yet this fine flower might be planted between two tall growing plants, and would fill up the space between them with good effect when growing and flowering. I have seen it growing in the open border, in front of a vinery, in the gardens of R. Harrison, Esq., at Aighburth, near Liverpool, where it was treated exactly like the *Fuchsia*; that is, the shoots were cut down, and the stumps protected by a covering of old tan. It had stood there for several years, and flowered abundantly every summer.

ESCALLONIA MACRANTHA (Large-flowered E.).—The best of the tribe, and a fine plant it is. Nearly hardy, but in the north it will require the protection of a preservative wall. In Messrs. Veitch's Nursery, at Exeter, it blooms freely without any protection; but the climate there is so mild. If there was plenty of space, other species of this genus might be grown in such a position, especially *E. grandiflora* and *E. organense*.

EUCALYPTUS.—The Gum trees of New Holland. Where the wall is lofty, and there is plenty of room, these plants would make a fine appearance, chiefly by means of their very fine silvery leaves. The blooms are not showy.

FORSYTHIA VIRIDISSIMA (Greenest F.).—This is one of Mr. Fortune's plants, sent by him from the North of China. The flowers are of a bright lively yellow, and appear on the previous year's shoots before the leaves grow. Flowering in the winter months, it is very desirable. Requires the protection of a glass-covered-wall, in order to produce its flowers in perfection.

T. APPLEBY.

(To be continued.)

THE PELARGONIUM.

(Continued from page 405.)

IN my last papers on these splendidly flowering plants, I gave full directions how to propagate them by seed to

raise new varieties, and by cuttings to preserve these varieties when raised. I shall now add a few lines on *grafting*, which is sometimes done for the sake of having two or more varieties on one stem, and this mode may also be useful for such kinds as may be difficult to increase any other way, more especially some of the so-called Cape species.

In the Royal Botanic Gardens, Regent's Park, there may be seen considerable numbers of *Pelargoniums* grown in the pyramidal form, that is, with an upright stem in the centre, clothed with branches on every side, the largest and longest at the bottom, close to the pot, and gradually shorter all the way up the stem. Now, when I saw these plants grown in that style, the thought struck me that such plants were well adapted for the purpose of being grafted with several varieties, and would then be exceedingly interesting. Such growers as may choose to adopt this mode should first grow a plant or plants to form a pyramid, and then graft any varieties they may choose upon them; or, if they do not adopt that mode, they may be grafted upon a plant grown in the usual bush fashion. The principal point to attend to is to graft upon any one plant such varieties as have similar habits of growth. For instance, it would not answer to graft a small-leaved weak-growing fancy *Geranium* on one branch, and a broad-leaved strong-growing kind of the ordinary varieties on the same plant, because, as may be easily conceived, the strong-grower would soon out-grow the weaker one. When it is determined, then, to graft any, place all weak varieties on a plant of similar habits, and strong-growers upon a vigorous-growing variety. Place the plants intended for grafting in a house a few degrees warmer than the greenhouse, and as soon as a free-growth is visible, then choose the scions or grafts from plants in the ordinary greenhouse. The bottom part of each graft should be half-ripened, and as near as possible of the same diameter as the branch of the stock.

The best mode of grafting is that known by the term cleft-grafting. It is done thus:—The stock is cut direct across, quite clean and smooth; the knife is then passed through the stem downward, about one-and-a-half inches. The graft is then made in the shape of a wedge, with a knife so sharp that the bark on each side is not torn or jagged. The slit in the stock must then be opened with the point of a knife, and the scion put into it, fitting the bark exactly to the bark of the stock; then tie it with some thick worsted, twine, or common soft bass-mat, firm enough to keep the graft in its place. Place these grafted plants in a shady part of the warm house, and syringe them every evening and morning; they will soon unite and grow, and should then be removed into the greenhouse, and stopped to make them bushy.

The best season for this operation is the month of April, though it may be performed at any time during the summer; but if done early, they will flower well the next year.

Varieties that are difficult to propagate by cuttings may be increased by grafting easily. These should be grafted upon small young plants, or even upon strong roots potted at the time, and placed in a gentle hot-bed till the grafts grow, removing them then into the greenhouse, and treating them the same as the rest that were increased by cuttings. This cleft-grafting is superior to any other method, because the grafts take full possession of the stock, and are then less liable to be broken off or displaced.

SUMMER TREATMENT.—This season I suppose to commence in March. I shall take it for granted that the stock of young plants are healthy, low, bushy plants, in 5½-inch pots. Now, to form a fine specimen, such as we see at the Regent's Park and Chiswick Exhibitions, a plant in March should have, at least, five branches, and plenty of fine dark-green foliage; the

branches should be all near home, and equal in strength. The pot will be full of healthy roots, and it will be necessary, about the middle of that month, to give it a shift into a larger pot, for the purpose of growing it on through the summer. That year it must not be expected to make much show; it should not be allowed to flower much, only just sufficient to prove the variety.

Previous to potting, the *Soil* to grow it in must be considered and provided. Procure a sufficient quantity of the grassy part of old upland pasture, not too heavy, nor too light. The former may be improved by a liberal addition of river sand; but the latter cannot be mended by any other way than adding strong loam to it. Cart it home, and lay it up in a long ridge, from two feet to two-and-a-half feet thick, with a base a yard across. Let it be well chopped, and laid up neatly. Turn it over about four times during the year, keeping it clear of weeds, especially such annual weeds as groundsell and chickweed, which are great exhaustors of the soil, and seed so freely that the pots will always be full of them. This implies that not only the heap itself should be kept clear of weeds, but also the compost-yard and ground in the neighbourhood. This soil, in one year, will be in fine order. The decomposed turf, and the exposure to the atmosphere, will generally have enriched the soil quite sufficient to grow Pelargoniums; but should it appear of a poor quality, add a small portion of well-decomposed dung—decomposed so much as to have a powdery appearance. Be careful not to make the soil too rich, for then the plants will have too much foliage, even to hiding the blooms. In nine cases out of ten the decomposed turf will be quite rich enough.

Having the soil in proper condition, place as much as is required in a place where it will become moderately dry, and aired, as it were, so that it will not give the roots a check by being too cold and wet.

The soil being duly prepared, then look out for pots and drainage. Have these in good clean condition. The plants to be potted having passed through the winter in 5½-inch pots, bring a few at a time to the potting bench; turn one out of the pot, remove the old drainage carefully, without injuring the young and tender roots; loosen them out of the soil as much as possible, without disarranging the ball too much. Shift them into 7-inch pots, and whilst they are in hand stop each shoot, and tie them out; that is spread the branches out on every side, leaving the centre open. This may be done either with short sticks, one to each branch; or by having a strong piece of twine tied round the pot just under the rim, and a piece of bass mat tied round each shoot, and brought down, and tied to the twine round the pot. The latter is the neatest mode, and dispenses with the always unsightly use of a host of sticks. So proceed with each plant until all are finished; then give a good watering, and replace them in the house. The kind of house best adapted for their culture will be our next consideration. T. APPLEBY.

(To be continued.)

RESTORING AN OLD GARDEN.

A CORRESPONDENT whose case, no doubt, resembles many others, has asked advice on the subject of renewing an old garden that has lately been much neglected, while, at the same time, he prudently disclaims all intention of incurring any serious expense in the process. Now, though it would be something worse than folly to say that such an alteration will not involve a considerable outlay, yet by going "the right way to work," the expenses will be very much curtailed.

Old gardens, if composed of a good soil, are generally preferable to entirely new ones, because, however bad the previous management may have been, there is usually "a

something" remaining that is useful: a few of the small fruits, &c., are sure to come in handy while the newly-planted ones are coming on: besides which, such permanent crops as Asparagus, Sea-kale, Globe Artichokes, and several other things, cannot always be reared into a profitable condition the first season; it therefore is advisable, in many cases, to let these standard crops remain until their successors be so far advanced as to take their places. This, of course, will depend on circumstances; but in the renewing of an old garden it is very good practice to disregard present appearances when there is a prospect of benefiting the future arrangement. Keeping this object in view, we, therefore, advise those coming into possession of such a garden to look round and see what alterations can, with advantage, be made; and one of the first considerations is,—What can be done with the *walks*? Can they be altered to advantage or not? The walls and other fences we shall suppose to have been attended to. The next thing is to ascertain if it requires *drainage*, and if so, do it effectually. Pipes, tanks, or wells, for the *supply of water*, must also be attended to, and either put in order or made afresh; and, in fact, every thing must be done that can be done consistently with other things to render it as complete as possible, and lessen labour and trouble at a future day. This having been done, and similar jobs connected with its internal affairs all put straight, it will then be time to look to the ground, and see what can be done to improve that in the way most suitable to obtain the best return for the outlay incurred.

In the first case, as we have said, it will be prudent to alter the *walks* if they require it; and at the same time plant thin edgings; although, for a small suburban garden, stone or brick edging would, doubtless, be preferred; but in most country gardens box is used, and certainly it is the best live edging we have. This being done, the bottom of the walk may be laid with such loose stones, brick-bats, or other rubble, as comes first to hand; and very often such materials are found in the course of operations going on, or, it may be, an old walk may furnish them.

We may observe, that walks within six feet of a wall, against which trees are planted, had better not be excavated too deep; about six inches is plenty of material for most walks where the ground is not very moist. The gravel for the top will, of course, depend on what the neighbourhood furnishes; but while heavy wheeling work is going on it is better not to finish them, leaving that to be done later in the season. We have not said anything of the width of walks, because that and their directions can only be determined by the circumstances of the case; but we may observe, that we would rather have one good wide walk than two narrow ones; anything less than four feet is certainly objectionable in any but the gardens of the cottager; above that we leave the limit with the proprietor. We have been thus prolix on walks, because they form a very important feature in all gardens, and in none more than that of the amateur, be his residence rural or suburban.

As it is reasonable to suppose that such a garden is to be rendered as productive as possible, rows of trained trees may be grown on espaliers on both sides of any central walk, and on the inner side of those running parallel with the walls. These trees may be either Apple or Pear; stone fruit rarely answers so well: the inability to train-in such large quantities of young wood every year on such fastenings as most of trellises are composed of, renders it inconvenient growing fruit of this class on ordinary trellis, but Apple and Pear may be trained in any way that fancy may dictate. Very often the interior walks are arched over by a frame-work of some kind, on which these fruits are grown with advantage and economy. In other cases they may be ordinary perpendicular ones, not to exceed five or six

feet high, and may be either of wood or iron, as taste and other circumstances dictate.

When a trellis does not margin a walk, it is usual to plant a row of *Currant* or *Gooseberry* bushes instead; these, by being planted about five feet apart and three feet from the edging, will give scope for here and there a small low-flowering plant being introduced between; but a much better flower-border will be formed by planting them further back, and allowing some three or four feet for a border for mixed plants. If this mode of planting out small fruits be carried out to any extent, less space will be wanted for those in the interior; but usually their fruits occupy about one-sixth of the whole ground; and if a similar portion be devoted to *Strawberries* and *Raspberries* one-third of the ground will be fully occupied. Mr. Errington has so often explained the best mode of dealing with them, that any remarks here are superfluous. However, apart from these fruits, there are other permanent vegetable crops requiring attention, and foremost amongst them is *Asparagus*, which, by its importance, deserves one of the best places in the garden; and the amateur would do well to give it all the indulgence compatible with his means. This crop may occupy something like one-twelfth of the whole; and if to that we add a similar space for *Sea-kale*, *Rhubarb*, *Artichokes*, and *Horse-radish*, then full one-half of the whole ground is occupied in permanent crops, leaving the other part for routine cropping in vegetables. Now, though we have stated the above proportions to be what we have in numerous instances seen, yet cases may arise in which a particular kind of vegetable or fruit may be more in demand than usual, when a greater breadth than is stated above may be planted accordingly; this, of course, must be determined on the spot, as well as the relative position of each; only we may advise that *Sea-kale*, *Rhubarb*, and *Horse-radish*, be planted on some outside place, if there be such, as they are generally disorderly crops at one time of the year or other.

In the disposal of the other cropping the amateur will have little difficulty, because the arrangement of the permanent things determine the features of the garden, and renders the others mere subsidiary objects; but some little care ought to be taken to apportion to each that amount of space, and no more, which its importance deserves; and if to that we add that *Onions* and *Celery* ought to have the best places, *Herbs* and *winter crops* the driest, and *summer Lettuce* and *Cauliflower* the dampest, we have given a brief outline to our meaning, and enabled the cultivator to crop accordingly. Of the treatment which each ought to have we shall say a something hereafter; in the meantime, the preparation of the ground for cropping, with the other routine work, will afford him plenty to do for some time to come; but the difficulties in the way of his succeeding in the culture of most of our common fruits and vegetables is much increased or diminished in proportion as the wants or taste of the party may determine.

The above notes will, in a measure, reach the inquiries of a correspondent, "R. H. G.," who has lately come into possession of an old neglected garden, but which, he says, contains many good natural points; and as he purposes going rather spiritedly to work, we advise him to obtain his fruit-trees, &c., from some respectable nurseryman, rather than incur the trouble and loss of time in grafting them; but, if he prefers the latter course, from a wish to gratify a laudable curiosity, he may obtain his stocks from a nurseryman, who will also inform him what kinds are best fitted for the district he resides in. This remark bears more especially on fruits, for each locality has its own peculiar kinds, while others do not always flourish there. Witness the fine samples of *Hawthorn Apples* that are seen in Covent Garden Market early in the autumn, which we know some

of the best apple-growing districts will not produce; but there are spots which do; while it would be vain in the midland counties fruit-grower competing with the Kentish one in the growth of *Filberts*, although the former may, as we have seen, beat in the matter of the common kitchen Apples. Now, our correspondent cannot do better than take a leaf out of the book of his neighbours, and select his common fruits from amongst the best of those which the experience of others has proved best adapted to the neighbourhood. Vegetables are, to a certain extent, subject to the same rule, in regard to the soil suiting certain things better than it does others, but the varieties of each kind had better be changed betimes; this, however, is an easy matter, and, in fact, is often done without the will of the cultivator, by having seeds from a distance; but as we propose to give a list of the best kinds of vegetables, we only urge on our correspondent to prepare his ground in the best possible manner, and, in so doing, not to disdain taking the advice of the labourer who does it; for be assured that, although he may be a stranger to the alphabet, yet his knowledge of the capabilities of the soil, and the best way and time to work it, will place his opinion, and still more his practice (prejudiced as they both may be), in a higher position than that of the most eminent horticultural chemist of the day, in so far as regards the cultivation of produce common to the district wherein he lives. But more of this anon.

J. ROBSON.

POULTRY PRIZES OF OUR AGRICULTURAL SOCIETIES.

THE Royal Agricultural Society of England has appropriated £100 for poultry prizes at its ensuing Gloucester meeting. The central position of that city, in the vicinity of Cheltenham, and within an easy distance of Birmingham, will probably bring together a large collection of fowls. We trust, therefore, that very careful consideration may be given to the system and classification on which the awards may be assigned.

Whatever may be said in anticipation of the Gloucester meeting, will equally apply to that of the South Western Counties Agricultural Association, which is announced for Plymouth.

On both these occasions, poultry will be exhibited as an adjunct,—as a class not contemplated at the outset of the Societies. We should be prepared, therefore, for some difficulties, but may fairly expect that every effort will be made to smooth them away by the avoidance of that confusion in the arrangement which proved so detrimental to success, both at Lewes and Taunton, in the past year.

All who from any motives are interested in poultry-matters, must feel obliged to these influential bodies for the patronage they have thus extended to the feathered inmates of our farm-yard.

So long as the principle of strictly maintaining the utilitarian characters of all poultry exhibitions is fully acted on, it will ensure public support. And though the time will come, the sooner, perhaps, the better, when extraordinary prices will be no longer realised, it will have happened from the fact that first-rate birds of the different breeds, have been widely disseminated; and have passed from the possession of the few to that of the many. The supply, in fact, will then equal the demand.

Some time, however, must elapse before this happens, and we have no fears, that whoever may now determine on becoming the owner of a good stock to commence with, paying for them accordingly, and looking to eggs or chickens for the partial repayment of his capital, will, as yet, suffer by his investment.

Poultry shows have done, and will still do good service, both to exhibitors and the public generally. The former have been thereby encouraged in their efforts to obtain the best and purest breeds, and the opportunity of comparison, and the introduction of the best strains of fresh blood has also been thus afforded them.

Nor have the public been neglected:—to say nothing of those, who, thus instigated by the external beauties of form and plumage there presented to their astonished vision, have zealously enlisted in our ranks:—The poultry-consuming classes, no unimportant fraction of the community, find that their money goes further, and obtains a better article than in days of yore.

More than one of the meetings which will take place at the close of the present year are likely to include "*dead poultry*" in their prize lists. Now, this would unquestionably be most appropriate, at both Gloucester and Plymouth; though, haply, from the season of the year, July, at which they are likely to be held, it may not be found feasible.

This *bonâ fide* assurance of our earnestness to consider the edible wants of the nation should carry us unscathed through many a good-natured joke on "extravagant manias," and "absurd enthusiasm," provided always the specimens prove not merely of aldermanic proportions, but with corresponding properties of acknowledged excellence.

However this may be, on one point we may venture to express an earnest hope, that the council of the Royal Agricultural Society will not another year so summarily abridge the different classes. Let us trust, for instance, that we shall see no "*Asiatic class*" rivalling in confusion "*the great Asiatic mystery*" of the author of 'Tancred,'—with Shanghaes, Brahma Pootras, Bantams, Silk Fowls, Malays, *et id genus omne*, huddled indiscriminately together.

From the expression, "*farmer's poultry*," to which it is announced that premiums will be awarded, we should presume that it is in contemplation to draw a bold line of demarcation between such birds as are to be considered valuable in an economical point of view, and such as are distinguished for appearance only.

The result of the Lewes show rendered some such step inevitable; and though the task is not to be coveted, we have reason to believe that those to whom it is likely to be entrusted are as equal to the work as any men in England. If our surmises be correct, we wish them well through it, though, probably, when their programme is announced, however excellent, both generally and in detail, some more earnest support than kind wishes may very possibly be needed.

The *Shanghae*, whatever questions are now at issue respecting his merits as a farmer's bird, must have his place, even if no higher ground were taken than the necessity of a more careful enquiry into his alleged merits than he has yet obtained.

Dorkings, gray and white, will of course receive ample encouragement; and no one will question the wisdom and good policy of liberality to this class, which, provided we could gain greater constitutional strength, would bear comparison with any in those points of excellence with which the farmer is mainly concerned.

Many persons are, indeed, sanguine as to the good results to be obtained by perseverance in judicious crossing, by which we might aim at attaining in one bird the weight and plumpness of the Dorking, the early maturity and hardihood of the Shanghae, and the laying properties of the Spanish and Hamburgs. The case of the short-horn cattle and the improved Essex pigs are quoted as cases in point, and we would not be thought to discourage such praiseworthy attempts when we say that our own past experience, with that of our friends, has not hitherto induced us to lay much stress on the advantages to be gained by crossing the breeds of fowls as yet known to us. We have not had in our own possession any of the *Scotch Dorkings*, as they are called, and which, we are told, are free from those traces of constitutional debility so generally apparent in their speckled and white relations. The birds shown to us under this name appear to have had an infusion of black-breasted red-game blood, which would, of course, tend materially to remedy the defect hitherto complained of; but how far their progeny may retain this character we should hesitate to pronounce upon, since cross-bred fowls have invariably been found by us to revert quickly to the habits and character of one or other of the original parents.

From the high encomiums passed on the *Pencilled Hamburgs* as layers, we should expect to see them included in the list of farm-yard poultry; the exclusion, therefore, of *Spanish*, which undoubtedly lay an equal number and a

heavier weight of eggs in the course of the year, and usually, moreover, at a season when better prices are attainable, would be difficult.

Nor, on the same ground, would general assent be given to the closing of the lists against the *Spangled Hamburgs*, and the *Polands*, both of which we have found equally good as layers with the *Pencilled Hamburgs*. The *Polands* especially, from their excellence as table fowls, would deserve a fair trial, though considered as delicate in constitution.

When we come to *Game fowls*, the difficulty seems on the increase, for this race already constitutes a considerable portion of feathered live stock of many a farm-yard; and their owners, therefore, would naturally look aghast at finding them banished from the catalogue of agricultural poultry—not but that we must admit that, however beautiful in appearance, and excellent as sitters and nurses, few birds have less claim for favourable consideration in a strictly economical point of view.

As regards *Turkeys*, *Geese*, and *Ducks*, present arrangements would require little, if any, alteration; but we would plead for the admission of *Pigeons*, which we conceive are no less generally a portion of farm-yard stock than they are confessedly in need of improvement. The introduction of some larger breeds might render the dovecot a far more lucrative matter than it can be now considered. But it is far from our wish to create difficulties, or raise objections to the course apparently indicated by the terms in which the Royal Agricultural Society has announced its intention of appropriating £100 to prizes for poultry at its ensuing Gloucester meeting. The more difficult and thankless a task awaits those to whom has been entrusted the drawing up of the prize list on that occasion, so much the greater claim will they have both on the forbearance and co-operation of poultry-keepers in general.

A line will then have to be drawn, of which few of those who entertain strong opinions on the peculiar merits of their own stock will at first be disposed to approve, however open to conviction when the question has once been fairly tested.

At the risk of being charged with repetition, we must yet refer to one or two points which have occurred to us as likely to influence the success of this as of all other exhibitions of poultry; at any rate, they deserve full consideration at the present time, before the arrangements have been finally decided on.

Would it not be prudent to put an end to all future discussions as to the issue of catalogues, by enforcing, in every case, a rigid rule, that *none should leave the printer's hands till the awards are announced*? In many matters it is easier to avoid the most trivial grounds of complaint than to explain them afterwards.

Another regulation that we would see put in force is, that beyond the assistants to the judges, to be selected from persons who can fully be relied on, and those who are employed to feed the birds, *no one should be permitted to be present while the judges are at work*. Much cavilling and discontent has arisen from the garbled statements of persons then in the room—remarks often imperfectly heard, constantly misunderstood, and, nine times out of ten, repeated abroad with much exaggeration.

A better system of *feeding* will be acknowledged by all as now required; and we need not add our opinion in favour of a *limitation of the period* during which the poultry are now often kept in their pens.

This leads us to consider how far Messrs. Jessop's recommendation for exhibiting in *baskets* may be deserving of adaptation. We presume its advocates would rest their case principally on two points—the avoidance of mistakes in transferring birds from their travelling abode to the exhibition pen; and the economy to the society in not having to provide the latter. As regards the first, we cannot but think that ordinary attention to the regulations and numbers of the pens, as given on the card sent with the hamper, would be amply sufficient to avoid such errors on the part of attendants. At any rate, competent persons might easily be found to whose hands this work might safely be entrusted. As to the argument of economy to the society by its not being called upon to provide the usual pens; we might answer, that such pens are now usually the property of the society, and are ready for use at

a trifling cost for their erection; but, to take the case of societies not already in possession of pens, we should still regard that outlay as advisable, not merely as regard to the far superior position in which the birds will be placed for exhibition, wherever light wire-net is substituted for wicker-work, but even with respect to the ultimate economy of exhibitors themselves. For it cannot be denied, that baskets of sufficiently light construction to admit a fair view of their inmates, will be but fragile receptacles for any lengthened journey, and the tender handling of railway porters. The first outlay will, therefore, be probably found the best economy to both parties concerned.

Another matter will demand careful investigation, and that is the most convenient place for the sale of such specimens as their owners may wish to part with. We are not convinced of the necessity of a price being put on every pen exhibited, but, on the contrary, we think that for many reasons "prohibitory prices" might be done away with, and the ticket "Not to be sold" affixed. However this may be, we would, at large exhibitions, postpone sales till the second day after admission has been given to the public; and however unsuccessful the late auction at the Metropolitan Show, some better-devised plan might probably remedy the evils

there complained of, and give a chance for the prize pens to those who, previous to purchasing, might wish to compare competing birds. At any rate, there would be no depreciation of his property to the owner, but rather the contrary, and the public convenience would be the better served.

At these summer meetings of the Agricultural Societies, what meaning will be given to the word "chickens?" Will they be chickens, strictly so speaking, of the current year? or may they date from any period within the previous twelve months? We suppose the former; but the present weather, and that which is proverbially, but truly, applied to our English March, will give but few opportunities of bringing pens in good form and condition by July; but this, with the then state and occupations of the old birds, is the common evil of all Summer Poultry Shows.

In repeating our thanks to the Royal Agricultural Society for the introduction of Poultry as a recognised portion of farm-yard economy, let us repeat also our assurance, that in all we now say, and have said, our sole desire has been to induce the careful consideration of the matters we have referred to before they have been permanently and irrevocably decided on.—W. W. WINGFIELD.

GARDEN PLANS.—No. 4.

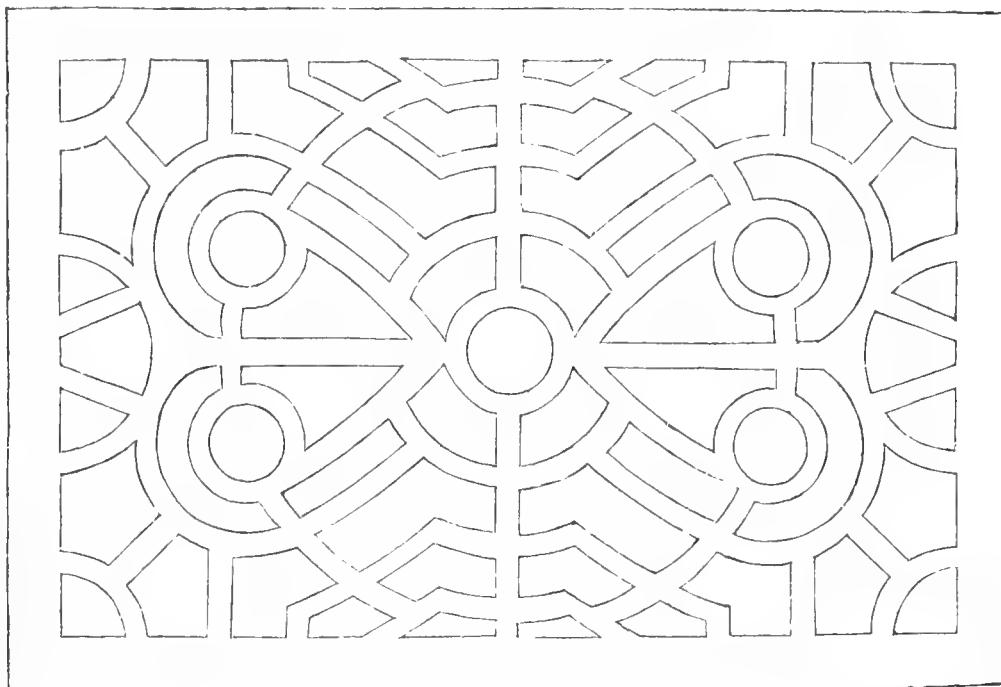

This plan was made by Mr. G. Lovell, an artist employed by Messrs. Standish and Noble, of Bagshot, and the principle of it is for showing off together the greatest variety of plants in a given space.

I have seen the situation of this garden, and I can vouch that it is very well chosen. It is opposite the drawing-room windows, looking to the south-east, and is considerably below the eye, with a raised terrace all the way round. Between it and the house there is a broad gravel terrace bounded by a highly-dressed stone wall, with balustrades, which are returned on both sides of the flower-garden; a flight of stone steps in the centre leads down to a second terrace, from which a second flight of steps leads to the garden, which is also on level ground. Miss Boulton, like Sir Charles Barry, objects, very much, to long flights of steps in a continuous line, hence her reason for the second terrace, so that the descent of the garden might be equally divided. It often happens that one has not the advantage of ground to allow for a second terrace like this, and in that case, the usual way is to divide the flight, or steps, into two or more portions, by "landings," or spaces of double or three times the breadth of one tread or step. All first-rate architects object to having steps, on terraces, and other parts in a garden, in even numbers, as 2,

4, 6, 8, and so on, and when they can help it, they do not rise more than seven steps without a bending, but five steps make the best proportion. A very common error is to have two steps to an architectural garden-seat, summer-house, or the like, instead of one or three. All these defects are strictly avoided in and about the gardens at Hasely Court.

This flower-garden is not quite finished yet, I believe. Miss Boulton understands the arrangement of flowers better than many first-rate gardeners, and she employs a thorough experienced gardener besides, so that this plan will be sure to be planted in first-rate style, and I may be fortunate enough to get a sketch of the planting as soon as it is determined on, or at any rate after an edition or two pass through their own hands. One thing I am aware of, and that is, that some of the beds will be in green all the summer, and some with permanent plants in them all the year round. These last beds, I should think, must be the very best of their kind, judging from the enormous quantities of herbaceous plants which Miss Boulton has been collecting together these last four years, from all the best nurseries in the country, and from the Continent. Indeed, I do not know of any private place where so many choice herbaceous plants could be now met with; and many of the rare plants which I have noticed for the last few months,

were noted down at this place. Besides, almost all the new and best plants that have been mentioned in THE COTTAGE GARDENER for the last three or four years, have been brought together here. If Mr. Appleby could call at Hasely Court, he would find there many of the best conservatory-wall plants.

D. BEATON.

SHANKING OF GRAPES.

So much has been written on this subject, that one is almost bewildered, but I cannot help giving Mr. Errington, in as few words as possible, the following facts:—

I have a vineyard on the side of an old sand-pit, in a situation so hot that I thought all the *Frontignan* and *Muscat Grapes* would ripen without fire heat, particularly as the soil is *everything* that a vine loves—a loose calcareous sand, in which *Hamburgh* vines, growing in the borders in the open air, will make shoots twenty feet long, and even ripen their fruit in hot summers, the bunches lying on the ground. Well, in the first crop my vines had, I found only a few of the *Frontignans* ripen, the remainder all shrank off, and were worthless. I thought it must be owing to a current of water, the result of a thunder storm, which made its way on to the border towards the end of summer. I was satisfied I had discovered the cause, and took means to prevent any more currents of water making such mischief. The second crop came in due course, and again my *Frontignans* were shrank. I imputed it to want of ventilation, but was not quite satisfied that I knew the cause. When the third crop made its appearance, I had air given in abundance, *night and day*, yet again my *Frontignans*, *Chasselas Musque* (or *St. Albans*), *Muscats*, and, indeed, all of the *Muscat* race were shrank. I could not blame the border, nor want of ventilation, for the following most cogent reasons:—*A vine of the Chasselas Musque is planted in the house, in the back border, which border is raised three feet, and, of course, from being under the glass, is perfectly dry. The grapes it has borne have hung close to one of the ventilators, and, in common with all the grapes of the same sort and same (Muscat) family, in the same house, they have always been shrank and worthless.* The *Hamburgh* and other sorts have invariably ripened well in the same house. *Frontignans* and *Muscats*, growing in a house within twenty yards of the above, with fire heat and abundance of air, *never shank*, and always ripen well. Now I deduce from all this, that *lowness of temperature* is the main cause of shanking, and that its cure, the borders being in decent order, is gentle fire-heat and abundance of air.—T. RIVERS, *Sawbridgeworth Nurseries*.

A VISIT TO DANTZIC.

THE voyager who proceeds from England to Dantzic, will obtain a fine panoramic view of the shores of Denmark and Sweden, with several islands of the Baltic. The distance is about 1000 miles, and the yacht in which I sailed reached it in six days. The Captain first brought to at Elsinore, for the purpose of paying the Sound Dues; a tribute levied by the Danish government on all foreign vessels, for maintaining the lighthouses, buoys, and other aids to navigation; but in amount so heavy, that a surplus finds its way into the Danish Exchequer. Commerce is not promoted by heavy imposts; and nations, to become wise, should learn to be just. The town is a small, dull, ill-paved seaport, with stores rather than shops, containing articles suitable for the crews of vessels calling there. Along the quays were arranged, side by side, a line of small sloops, with wooden sheds erected upon the after-part of the decks, the ends of which lifted up, and formed an awning over the mouth of the hold. These were the provision boats from the neighbouring islands; and on descending by a plank, you found yourself in the midst of butter, cheese, eggs, hams, bacon, fowls, sausages, strings of smoked geese, ducks, &c., in fact all the conceivable produce of a small Danish farm.

Leaving Elsinore, we next cast anchor in the heel of Dantzic, a broad and deep bay, at the bottom of which stands the little village of Freshwater. Here our voyage terminated, and the Captain again landed, to submit his papers to the inspection of the harbour-master, and to

undergo the examination of the Custom-house. If Prussian commerce declines, it will not be for the want of fiscal regulations. Dantzic is situated five miles up the Vistula, which here empties itself; the town belongs to a bygone century, having rows of streets running from north to south, like the bars of a gridiron, and terminating on a line of quays; each street being shut in at night by folding gates. The portions of the town not bordered by the river are enclosed by a fosse and ramparts; and an outlet into the country is across a drawbridge. I reached Dantzic late in the evening, and having taken up my quarters at a comfortable hotel, found the next morning, on rising, that my chamber window opened on to a balcony; and being over one of the gateways looked directly up the centre of the street. This centre was filled by two rows of trees, which mingled their branches at top, and formed beneath a beautiful arcade. The houses stood with their gable ends to the street; and between them and the trees was a raised terrace about twelve feet wide, with a stone balustrade in front, the space being subdivided into small courts; these were usually benched round, and here the occupiers displayed their merchandize, and of an evening chatted and smoked their pipes.

In the principal street was held the provision market; eggs were forty for a shilling, butter sixpence per pound, fowls averaged one shilling each, and vegetables were inferior in quality and low in price. At the upper end of the town, in a large square, was the hay and straw market; provender of this kind being in request for the troops. Its chief characteristic was the number of blue blouses and small caps worn by the peasantry; and their little antique waggons and horses, with long rope traces, apparently more adapted for entanglement than draught. The fish market was on the quay, having an abundant supply of odd-looking fish, for the Baltic is not salt, but brackish; and its finny tribes vary from those of our shores. The beautiful sturgeon, so rare with us, appears in great abundance, from six inches to four feet long. Fish enters largely into the diet of the inhabitants; and dried fish, with rye bread, is much consumed by the lower classes. In the secondary streets every kind of trade seems carried on out-of-doors; you encounter pump-borers, carpenters, trunk-makers, smiths, merchandize of all kinds, and men splitting billet-wood for the German stoves. Piles of the latter often block up the pathway; and it is not too much to say, that a man will split double the quantity in one day of an English workman; their axes are long and narrow, every blow tells, and skill lessens labour. Fowls mingle with the throng, chiefly a mongrel race; but dogs are peculiar for their fox-like heads, pricked ears, deep fur, and curly tails, and are mostly white or fawn coloured. But amidst all the display, it is often difficult to find what you wish for. I wanted a barber, and was directed to a round flat brass plate hanging over a doorway; the barber was a woman, and shaved me well. A woollen draper's sign was a chest, with a slit on the top, like a money-box; shoemakers, saddlers, and others, had their wares painted on the window-shutters; these, though grotesque, were intelligible; but small wooden images, with a pair of scales in one hand, and a hank of red worsted in the other, puzzled me exceedingly. These were workers in amber and made beads, crucifixes, and other articles used in Catholic worship. Amber is dug up in the neighbourhood, and indicates the site of an ancient forest. Insects are found in amber in a high state of preservation, showing that the substance was once a fluid gum; and entomologists who desire fossil species differing from our living ones may here obtain them. "Look here," said our captain one day to me, casting his eye over the side of the vessel; it was a flight of mosquitoes set fast on the warm tar. Had these alighted on the gummy trunk of a tree, and a fresh exudation passed over them, they might have gone down enshrined to posterity. Antiquaries, who prize articles of *vertu*, so far as primitive form and workmanship are concerned, would find Dantzic a museum.

Corn is the staple article of export. A large hall in the centre of the town, and which serves as an Exchange, is where the business is carried on. Jews are the principal merchants. They are the Josephs of Egypt, buying up the corn of the provinces. A long table runs down one side of the hall, on this are placed large wooden bowls, containing

the different samples of grain; this grain is brought down the Vistula. When the distance is not great, it arrives in covered barges, containing about 150 quarters, but when it starts from the interior of Poland, it is placed in uncovered flats, these are about seventy-five feet long, twenty feet broad, two-and-a-half-feet deep, draw six inches of water, are rudely constructed, and hold from 200 to 250 quarters; they are generally navigated by four or six men. The corn is ridged up like the roof of a house, and being exposed to the weather, soon vegetates, and the shooting fibres form a felt, which protects the mass. In this state the raft moves along, like a floating green island, and is often weeks, if not months, on its voyage. When it reaches the wharf it is unloaded by women, assisted by one or two men to direct the operation. These women work in gangs, from ten to fifteen in each. The outside or matted covering of the heap is first peeled off, a huge sail cloth is then brought to the side of the raft, and the women placing themselves in rows upon it, throw the grain, by means of shovels, from one to the other, taking care to separate the kernels as much as possible. At night, and during showers, it is ridged-up and covered with a cloth. Thousands of quarters of the finest wheat may often be seen undergoing this process. When sufficiently dried it is taken to the warehouse; these warehouses form a line of lofty brick buildings, with their gable ends facing the quay; they are seven stories high, three of which are in the roof; two rows of pillars support each floor, running down the centre, and form a passage, boarded about four feet up the sides, the space between the pillars and the walls is divided into compartments or bins for the different kinds of grain, and each floor will hold 400 quarters. When a vessel is to be loaded, six or eight porters advance with long bags, similar to a bolster-case; two fillers stand, one on each side of the heap, holding in their hands an oval wooden scuppit, like a butcher's meat-tray with the corners cut off; one end of this scuppit is inserted into the corn, and the other is tilted into the mouth of the bag held by the porter to receive its contents; in half-a-minute the bag is filled, and by a simultaneous jerk is placed on his shoulder, one-half hanging down before him, and the other behind. He gives place to the next, and by this method a vessel carrying 500 quarters is loaded in from three-and-a-half to four hours.

To return to the raft; when clear of its cargo, it proceeds to a lofty brick tower, which has a projection overhanging the river; here the top of its tall mast is secured to a pulley, which gradually lowers it over the stern, and finally it reaches the timber-yard, where it is broken up and sold for firing, or the dunnaging of ships. The men who navigate these rafts (and there is often a woman among them), are a peculiar race, with long black hair, dark features, and sun-burnt skins; their dress is little more than an inverted sack, with holes to admit the head and arms drawn over them, short wide sleeves, a pair of trowsers, and a girdle of the same hempen material; they wear also a felt cap of the form and colour of our Stilton cheeses, and happy would it be for the poor creatures if they were cheeses. They appear to have no under garments, and their chests, legs, and feet are bare. The women dress like the men, save that they wear a short petticoat of the same course fabric, instead of trowsers, and a handkerchief round the head in the place of a cap.

There is not a single garden in the town of Dantzic that I am aware of; at least not one worthy of the name; this is owing, probably, to the density of the population, and the limited space afforded by the fortifications. But there are public gardens outside the city walls, and these are much frequented, though floriculture does not appear to have entered into the taste of the inhabitants. It was in a small lake near one of these gardens that I met with the beautiful little *Rana esculenta*, or Edible Frog; it abounds also in the fosse which surrounds the ramparts. They are very difficult to capture, and when caught, require some compression of the hand to retain them, and if relaxed they shoot from it like a pellet from a pop-gun. These frogs are about half the size of our English ones, far more elastic, and will spring from six to eight feet at a bound. They have a high protuberance on the back, rising to an angle between the shoulders; their colour is bright amber, with rows of black spots from the head to the rump, others are of an olive-

green colour; they appear to live in colonies, and on a signal being given, the clatter and din of their voices in full chorus is deafening, this lasts for about a minute, and these outbreaks may be heard at half-a-mile distant. They might serve to ornament our parlour aquariums, provided, however, that the latter were wired in.

The environs of Dantzic are interesting, from the circumstance of a hill rising to the north of the town, and the approach of the noble Berlin road, sixty feet wide, and bordered with rows of lofty trees. The country round is not highly cultivated, and is destitute of improved agricultural implements and farm buildings. Women may be seen working on the roads, filling muck-carts, and driving the plough. Prussian policy, which requires men for the army, checks industry, and retards the advances of civilisation.

The landlady at my hotel was a notable personage, with a large bunch of keys at her girdle; she appeared like the sun in the centre of her attendants—around her they traced their circle, and from her they borrowed their light. She spoke nine languages; and it was a great treat every day at our *table d'hôte*, which was usually frequented by the captains of vessels from various foreign parts, to hear her conversing with each in his own tongue, though seven or eight languages during dinner were not unfrequently spoken. On my asking her how she acquired such versatility of speech, she said—not by books, for she rarely opened one, but by *talking*: a grammar, according to her notions, should come last, and only to finish off with. She had two fine sons, about seventeen and eighteen years of age. "What trade do they follow," I enquired? "They have been six months on my hands, expecting every day to be called into the army or navy: our Prussian conscription law requires every male to serve for two or three years; and who will take lads to teach them a trade, when they are to leave at a week's notice. That law destroys our liberties under the plea of protecting them; it deprives us of our children when they most need our care; and too often returns them upon our hands idle and demoralised, and unfit to settle down to any industrious pursuit. Our evil is in having too many defences; defiance begets hostility, and no town has suffered more from the ravages of war than Dantzic." War is certainly a monster; it creates war, and then devours its victims. "How is it," asks a celebrated writer, "that the greatest crime, and the greatest glory, should be the shedding of human blood?"

I had spent eight days in Dantzic when the captain informed me that he was ready to return. To show the cheapness of living, my breakfast, with French rolls and coffee, dinner of five or six courses, tea or coffee in the evening, ale and liquors at pleasure, and lodging included, was 3s. a day!

On our homeward voyage we were detained by adverse winds among the islands of the Baltic, and had an opportunity of trading with the natives, who came off to the ships with provisions, and offer them in barter; we also brought to at Copenhagen, and reached the Schaw, or northernmost point of Denmark, when our troubles began; for on rounding this point, a strong head wind, blowing in squalls, with rain, and a heavy sea meeting us from the German ocean, threatened to detain us; but the captain grew restless, and knowing, as he said, what his vessel could do, he would work his way down the Skager Raek; accordingly, everything on deck was made fast, the hatchways battened down, and tarpaulled over, and the men put on their oil-skin dresses. Orders were then given to tack, when the little vessel tilted on one side, and whistled through the waves and spray. I fixed myself on the cabin stairs, and looked over the partition which encloses them, like a man peeping out of a chimney-pot. "You'll not stand there long," said the captain. He had scarcely spoken, when a wave cascaded over me, and flooded the cabin-floor. Not liking to be baffled, I procured a waterproof dress, and was lashed to the railing on the upperside of the deck. What a wild and tumultuous commingling of the elements! The lee-side of the deck, together with the bulwarks, were for the most part under water; and when the vessel pitched, the waves came over the bows, and rolled from stem to stern; during these moments, the man at the helm stood up to his breeches-pockets in water, and everybody and everything was completely drenched. To me it was a scene of grandeur—a pic-

ture of God's wonders in the deep. For two days and nights, with slight intermissions, we continued thus to battle with the waves, until we came alongside the Dudgeon Light, on passing which, the man on the look-out exclaimed, "Why you have had a rough time of it." "Aye, aye," said the captain; and in another tack or two we were in the Yarmouth Roads, and cast anchor among a fleet of vessels which had already taken refuge from the boisterous weather.—S. P., *Rushmere*.

ARTIFICIAL SWARMS.

I AM SURE I ought to have written to you before this, to tell you something of my success and otherwise in the apiarian department, if only for the gratification of our good friend "A Country Curate," who has so often urged your readers to send word how they get on, and I wish him to know the result of my attempt at "artificial swarming" during the trying summer of last year. I find, from my memorandum-book, that the bees in a straw stock-hive (a swarm of 1851, on the old system,) began *clustering* at the hive's mouth on the 5th of June. Not wishing to lose them, I kept some person constantly watching when there was any probability of their swarming. On the 8th they came out in greater numbers; and one (to me) remarkable circumstance was, that I had never seen a single *drone* during the season, though I had watched for them half-an-hour at a time. On the 10th, a drone in a state of chrysalis was cast out of the hive *dead*. On the 19th they clustered again; and on the 20th in greater numbers than before, and remained out all the afternoon, and some of them all night. On the 21st and 22nd they were still at the old game, and remained out during a heavy shower. This was provoking work; and on the 23rd I tried to *drive* them into another skep, on the plan recommended by "A Country Curate," except that I made the attempt in the *evening*. I only got a few to ascend. On the 24th I tried again, between seven and eight, A.M., but with worse success, though I beat about the sides with a long cane for ten or fifteen minutes incessantly, until my arms ached again. Now I thought it time to try some *new dodge*, if perchance I might succeed; so I got some rags steeped in a solution of saltpetre, and put a new hive under the stock, and fumigated them: some 20,000, or more, fell down into it. When they had recovered a little, I took the new hive and placed it in the position of the old stock, removing the latter eight or ten yards away. However, it would seem her majesty had not condescended to accompany this portion of her subjects, for, shortly after, they began to leave the new hive in great numbers. They found out the old hive, and in two or three hours had all rejoined their queen and companions. Finding it was of no use, I removed the stock back again to its place, until I should decide how to act with these ungovernables. I do not believe I lost more than a dozen bees over this experiment. I found plenty of drones in the hive to-day, but none of them seemed able to fly. On the 25th they were out again, by half-past nine, A.M.; and on the 26th it was the same, although it was pouring with rain: they stood it bravely. On the 27th, 28th, and 29th, they still pursued the same line of conduct, and were, of course, hourly expected to depart. (On the 27th I saw some drones, which were the first I had seen in my apiary, leaving a wooden hive.) On this day (the 29th) I repeated my former experiment, wishing to end the matter; and, in addition to the fumigation, gave the hive several smart strokes with a stick, hoping to dislodge the queen. I then placed them on the *old* stand, and removed the stock to a distance, and *made it up* during the night, it being then between three and four, P.M. Finding, on the 30th, that the "artificial swarm" seemed to take to their new home, and to be going about very contentedly, I set those in the stock at liberty about ten, A.M., and found no inconvenience from so doing. On the 4th of July they had formed a piece of comb, about the size of my hand, and filled it with honey. On the 12th, I took a box of honey (a stock box); and finding a quantity of young brood in the combs, I put them into a box, and placed the "artificial swarm" over it, thinking they (the young bees) would materially strengthen it. On the 20th, I found nearly all the bees in the "swarm" in the bottom box

nursing the larvæ, and scarcely any left in their own hive, *not sufficient to defend* it from a host of robber bees which surrounded it, and seemed resolved to take the place by storm. I narrowed the entrance, and at night took the bottom hive away, and placed most of the brood comb in the straw cap. I am afraid you will find this a very uninteresting tale, but I want you to know the end of the matter. On the 2nd of August, thinking all was not right, I examined the artificial swarm, but could neither find a queen, nor any brood in the comb, though I looked them over, almost one by one, *three* times, yet I could not find her. I looked for her a few days after, but could not find her; and on the 31st, both bees and honey seemed to be dwindling away, so I joined them to another stock.

With my box-hive, mentioned before, I had better success. I wished to transfer the bees from this plain box into one of Taylor's Bar-hives, and so I put the stock on the top of the bar-hive on the 1st of July. They were quite full, and began to work in it directly. On the 5th, they had made three guide combs four inches long, and commenced two others. As I wished to remove them to the bar-hive stand, I began by moving both together a little forward, until I got them on an old tub (in a day or two) in *front* of their *old* stand. There was a straw stock close by likely to swarm, which I wished to prevent, as it was so late in the season, and had put the bar triplet under it for that purpose. The bar-stock under the box was full of bees when I placed it on this tub; but what was my surprise, when I looked into it a short time after, and found it *deserted*; and turning to the triplet under the straw hive to find it literally crammed full of bees! It was evident the bees did not like the change, and had gone in a *crowd*, I should suppose, to the other hive, and had overpowered the few bees at the entrance, and actually taken *possession* of their bottom hive. I took the box away immediately, and compelled the mass of bees to quit it. Many of them returned to their own hive (now restored to its original position), but many clustered at the mouth of the straw hive. I took them away by hundreds, and placed them on the alighting board of their own hive, when they immediately entered unmolested, and took possession of their former home. I never heard of such an instance before. I suppose you would call that "fraternisation." Well, on the 12th, I took this old wooden stock-box by fumigation, and compelled the bees to enter the bar-stock. I had to fumigate three times, and brush them out with a feather before I could come at the queen. The bees were flying about in all directions, evidently at a loss for their sovereign. I took her majesty and placed her on *one side* (the box being tilted); the bees seemed to recognise her instantly; she was surrounded by them, caressed, fed, and led into the hive, and in a few minutes all was quiet again. The gross weight of the box taken was 46 lbs. It weighed 24½ lbs. on the 6th of May. On the 20th of July I weighed the bar-hive I had driven the robbed bees into, and found it weighed 35 lbs. The bees were admitted on the 1st, confined to it altogether on the 12th; and thus the net weight of bees and honey collected in twenty days was 18 lbs.

I will conclude this subject, which I hope will, at least, *amuse* our good apiarian friend "A Country Curate," by saying, that having saved last year a quantity of seed of the favourite bee-flower, "*Melilotus leucantha*," if any of your readers who are bee-keepers wish to be supplied with it, and will send me a *directed* and *stamped* envelope, I will return it to them with some of the seed. It is sown in April, and the second year grows eight or nine feet high, and is a mass of flower. I got the seed originally from Dublin, through the kindness of Mr. McGlashan; and now I wish to give to any other amateur the opportunity of possessing himself of this excellent bee-flower.—J. R. JESSOP, *Governor, Sculcoates Union, Hull*.

HOT-WATER BOTTLES IN A SMALL CONSERVATORY.

I HAVE often noticed that our friends, Messrs. Beaton and Company, advocate the use of bottles of hot-water in small glass structures, but never thought of employing them

till this winter. On the first approach of the late inclement weather, I endeavoured to light a fire in my furnace, but from the dampness of the flue it proved a very tedious and unpleasant affair; I therefore abandoned the task, and instead, filled a three quart bottle with *boiling* water, and placed it on a stool in the house about ten o'clock at night; I found this to answer the purpose admirably, the thermometer at seven in the morning standing at 34°. I have repeated this nightly to the present date (February 21), and seconding the hot-water-bottle by closing the lights while the sun is on them, am so satisfied with the result that I shall not again attempt to light a fire.

I should add that the house is 10 feet by 7 feet, and 14 feet high; is in a sheltered position, with a wall on the north and west sides; is, moreover, glazed with sheets of glass three feet long. This is, of course, all in its favour; still there may be many similarly situated to myself, who may think a flue absolutely necessary to repel the frost, who would be gratified to know that it might be done by simpler and less expensive means.

With a lower house than mine, and the addition of an outer curtain to hang on at night, I feel certain I could repel the sharpest frost likely to occur in this latitude.—W. SAVAGE.

BANTAM FOWLS.

Of these elegant little pets there are several varieties, the first of which, I believe, were imported from Bantam, a town and province of Java, whence the name. They were small fowls of a light red colour, with black tails, and black markings in their hackles, single-combed, and clean legged.

Another imported variety is the feather-footed Bantam, which, I believe, was brought from China; of this sort there are three colours—the nankeens, or light buffs, with black tails; the quite white; and the blacks—all with single combs and feathered feet. To these may be added several varieties of small fowls known by the name of Bantam, and most likely produced originally from them, with a slight mixture of some other fowl, and by in-and-in breeding reduced even below the size of the true Bantams.

The first of these I shall bring to notice is the old *Spangled Bantam*, a most beautiful little bird, though almost forgotten, and nearly lost. The ground colour is of a bright red, slightly streaked with black, every feather being tipped with white, giving the fowl somewhat the appearance of being set with pearls; the quill feathers of the wings and tail are mostly white, grizzled with black; the white spots on the hens are larger than those on the cocks; they are feather-footed, and often rose-combed.

The *Golden Pheasant Bantam* next claims our attention. The colour is of a bright red, the feathers having a spot of black at the tips—from this reason they are called Pheasant, because of the resemblance of this marking to the dotted appearance of the pheasant's neck, and not, as supposed by some persons, from any mixture of the breed with pheasants. These are well-made birds, with rose-combs, and smooth green legs, but are generally rather large for Bantams, which strengthens my opinion that they owe their origin to a cross with the Golden Pheasant Dutch breed.

The *Laced Bantams* are of two varieties—that of gold and silver, being distinguished by the ground colour, the feathers having a narrow edge or border of black, which gives their wearer a scaly or imbricated appearance. Like the last, they are rather large, with mostly rose-combs, clean greenish legs, and they are good layers, from which reasons I suspect them to be derived from a mixture with the Dutch Every-day-layers of the same markings.

Sir John Sebright's beautiful little Bantams are of this variety, reduced in size by careful breeding. Their hackle, saddle, and sickle feathers are short, the last remarkably so, that they almost resemble the other tail feathers; the colour of cock and hen scarcely differ, and they carry themselves exquisitely.

The *Game Bantam* is a charming little fowl, produced between the Game fowl and the Bantam, and by patient and careful breeding brought to resemble a diminutive Game cock of the black-breasted red variety, with single comb and clean yellow legs, with flowing saddle and tail

feathers. To these may be added a perfectly *white*, and a quite *black*, variety, each with clean legs and rose-combs.

Common Bantams present a very great variety of colours and markings, sometimes approaching one of these varieties, and often differing entirely from them. I have seen some tufted, and once saw a five-toed Bantam. They are interesting little pets, and may be kept where other fowls would be an annoyance. Some of them lay exceedingly well; the eggs are small, but very nice, and the chicken of the preceding summer make a good substitute for early chicken, with asparagus.

Bantams are good nurses, and are sometimes used to rear young pheasants and partridges.—B. P. BRENT, *Bessels Green, near Seven Oaks*.

TO CORRESPONDENTS.

* * We request that no one will write to the departmental writers of THE COTTAGE GARDENER. It gives them unjustifiable trouble and expense. All communications should be addressed "To the Editor of the Cottage Gardener, 2, Amen Corner, Paternoster Row, London."

AN OLD GARDEN (R. H. G.).—You will see Mr. Robson has, to a certain extent, met your enquiries. In addition, we have only to advise you to trench up nearly all the *Strawberries* that are run wild, and to plant young ones on a separate piece of ground. For the first year restrict yourself to *Keen's Seedling* and the *Elton*; you may also plant a small breadth of the *Falstaff Raspberry*, but do not destroy all your old ones. Though they are wild they will produce something. The same may be said of a few *Strawberries*. Reserve, also, a few of the best *Gooseberry* and *Currant* trees, and plant young ones elsewhere to replace them; and on the site of old plantations vegetables may be planted with advantage. In arranging your *walks* do not have too many; and the walls being low will not allow the trees against them being planted thick. Your north wall, 150 feet long, will not hold more than eight trees properly, which might be two Royal George *Peaches*; two *Elrue Nectarines*; one brown *Ischia Fig*, if the climate be good; one *Moorpark* and one *Orange Apricot*; and one *Greengage Plum*. The latter may, however, be substituted for another *Peach*, if thought well of. The east wall may be planted with *Apricots* and *Pears*, and the west one with one *Violet Hatve Peach*; one *Red Roman Nectarine*, and the remainder *Apricots* and *Pears*. The fence you speak of as bounding the garden on the south would be better removed if you propose taking in part of the adjoining field. We advise that the works be not extended too far at once; it is better to do well what is attempted than to grasp at too much. Your other enquiries will have been met by the articles of our coadjutors in this and the last week's paper; but other observations will follow equally serviceable to you.

COMPOST FOR CALCEOLARIAS AND CINERARIAS (J. R. Jessop).—*Herbaceous Calceolarias* thrive best in a good, fresh, turfy loam, without any manure of any kind. If the soil is made too rich they are apt to die off suddenly. *Shrubby* kinds will require an addition of one-fourth leaf mould. The soil for *Cinerarias* should consist of two-parts loam, one-part peat, and one-part leaf mould, or very-well-decomposed hotbed manure, with a liberal allowance of river sand.

BALSAM-SOWING (Amateur).—Balsams to be shown on the 30th of July should be sown about the first week in April.

EGYPTIAN FOWLS (A Constant Reader).—We are not aware of any distinct variety of fowls known as *Egyptian*. Those we have seen from that country have usually represented mongrelism in all its bearings; and, with the partial exception of one feature, an upright single comb, like that of the Spanish, which, however, is far from universal, they are utterly devoid of any general characteristic; but when we remember the immense numbers that are there produced by artificial hatchings, the eggs for which are collected without any reference to the breed, no other result could be expected. If our correspondents on such inquiries would send brief notices of the form, colour, and figure of the birds in search of a name, with a few feathers, and the colour and shape of the egg, our task would be more easily and satisfactorily performed.

PLANTING CONIFERÆ (Two Inquirers).—You inquire what distance the *Cedar of Lebanon* and the *Deodar Cedar* should be planted from each other, so as never to injure each other at any period of time? The *Cedar of Lebanon* spreads its branches horizontally, and when old these cover a great extent of ground. There are specimens in this country, the diameter of whose head exceeds a hundred feet. The *Deodar* does not spread its branches to near that extent, consequently, does not require so much room. Sixty or eighty feet would be a safe distance to plant these two trees asunder. Other coniferous plants do not require so much space; forty or fifty feet would be ample allowance, and even that depends upon the habit of the species. Many of the genus *Juniperus* are upright growing trees, occupying a space not more, even in very old specimens, than ten or fifteen feet. These may be planted still nearer, as also may the *Arbor vitæ* tribe. You must study their habits, and plant accordingly. You inquire, also, what distance such shrubs as *Yews*, *Laurels*, &c., should be planted from each other. The *Yew* is a spreading tree, and should be allowed at least twenty feet diameter of space; but *Laurels* do not require quite so much. You ask, also, about deciduous trees, and the *Pine* tribe generally, what distance apart they should be. These should be planted rather thickly at first, and regularly thinned as they advance in size. If you wish to carry out your views, plant first such trees as you intend to be permanent, and fill up amongst them other trees to serve as nurses, till the permanent trees require more space; the nurses can then be gradually removed, either to plant again or to make stakes and fire wood. This plan is much to be preferred to planting the

trees that are to stand for posterity at the distances they will occupy when fully grown. This, of course, depends upon the extent of your plantation. If you are about to plant an Arboretum and a Pinetum, you ought to call in an experienced man who thoroughly understands the art of planting, and is well acquainted with the habits of every kind of tree you wish to plant. He would point out at once the space of ground your permanent trees each of them would require. To give full directions on every tree you name would occupy a volume; besides, a great deal depends upon soil and situation, of which you do not say a word. In thin soils, and exposed situations, the permanent trees will never grow so large as they would do in good soil and sheltered places.

CAPT. HORNBY'S SPANISH FOWLS.—“IN THE COTTAGE GARDENER of February 17th, I observe, with extreme surprise, an advertisement signed by Timothy Mason, asserting that he has Spanish fowls and eggs from different breeders, including Mr. Poole, who, he asserts, is the breeder of *Captain Hornby's best birds*. To this statement, I am bound to give the most unqualified denial. I have not got one fowl in my yard of Mr. Poole's breed.—WINDHAM HORNBY.”

SALVIA-SOWING (D. J. M.).—The blue and scarlet Salvias will flower in the autumn from seeds sown now in heat, and kindly dealt with.

POLAND FOWLS (Scrutator).—In our previous remarks on your communication, the extreme beauty of the specimens of Gold and Silver-laced Poland sent for inspection was duly noticed. We are strongly, however, of opinion, that both form and carriage are no less to be regarded than mere beauty of plumage, and that the union of the three is essential to constitute a perfect bird. Indeed, we cannot even assent to your opinion that plumage should occupy the post of honour. In these days, moreover, a fourth test will probably be insisted on by the public, and that is excellence in an economical point of view; and we cannot but regard this demand as both just and equitable. You have placed a wrong construction on our words, in reference to our allusion to the *spangled* birds as distinct from the *laced*; this does not necessarily infer a distinct origin or parentage, but simply distinctness of appearance; just as we should speak of the single and rose-combed Dorkings as distinct; though, very possibly, as in the case of these Polands, both were hatched from the eggs of the same bird. The true laced birds should have the preference; and had your friend been disposed to exhibit at the late Metropolitan Show, he would have found the judges well-disposed to acknowledge the beauty of his favourites, supposing them meritorious in the other necessary points. But, at the same time, good birds have been shown, and distinguished by prizes, where the markings partook more of the nature of a spangle than lacing. You must remember, that on the subject of *beards* or *no beards*, many Polish fanciers, who have long and zealously given their attention to the subject, hold for the former as stoutly as you would argue for the latter. A letter is even now before us, from one to whom every variety of Polish has been the subject of diligent enquiry, and his specimens have been obtained from all parts of England, and also from the Continent, and with him, beards are viewed in the most favourable light. We do not, ourselves, here express any opinion as to the propriety of their presence or absence, but would leave it, as the Birmingham and other Poultry Societies have themselves done—an open question for further consideration.—W.

ADVICE (Anti-humbbug).—We are exceedingly obliged by you, or by any correspondents, taking the trouble to point out what you or they consider erroneous in our pages. Such advice is always read patiently, though often occasioning a smile at the total forgetfulness by the writer that his judgment may, perchance, not be in unison with the judgments of a majority of his fellow-readers. We endeavour never to lose sight of the objects for which this Journal was established—the improvement of the gardening, other rural occupations, and domestic comforts of the majority of our countrymen. As our circulation, and, consequently, our profits have increased, we have increased the number of our pages; but we cannot give that increase entirely to gardening. We give now, and shall continue to give, double the amount of horticultural information that any other weekly publication affords for twice the price. It may seem to some that we have given, lately, too large a portion of our columns to poultry intelligence, but it has been only in accordance with the growing desire for information relative to that useful description of agricultural stock. That information has been most valuable, and we shall always dwell with satisfaction on the aid we have been empowered to give to this source of comfort, pleasure, and profit, to so many of our countrymen. This information will continue to be afforded, but by degrees it will not be so largely required; and we are making arrangements to have a department devoted to that numerous class of readers who require information as to farming the few acres they hold. It will enable us to afford, however, some hints to those who are more extensive agriculturists; will be equally useful to allotment holders, and shall not trespass in any way upon the space we have uniformly devoted to gardening.

DR. LATHAM'S MODE OF PRESERVING ANIMALS.—*Scrutator*, and some others, have quite mistaken our object in publishing this. We did not intend it for more than we stated—an interesting, unpublished MS. of that great ornithologist. To put the matter beyond all doubt, we publish the following from a very obliging note signed M. D.:—“As a regular subscriber to, and reader of, your COTTAGE GARDENER since its commencement, and from whose pages I have derived both pleasure and much information, I am naturally anxious that all its articles should be of first-rate quality, derived from the most modern and best sources of information, and the data confirmed by the practice of the best modern artists in their respective departments. I have been led to make these remarks from reading an article in yours of the 16th of February, on the Preservation of Birds, &c., by Dr. Latham, whose directions (whatever his ability might have been considered in his day) must now be thought obsolete, completely out of date, and useless. The merest tyro in the art, now-a-days, would laugh at the baking process, pinning down the specimens, cutting out the flesh, the preserving powders, the painting black beads for eyes, when glass ones of every shade and hue may be bought for a mere trifle, &c., therein described. Animal specimens of every kind were never better preserved, or set up, than at present; witness the celebrated Waterton's, surpassed by none, the beautiful collection of Humming Birds shown at the Zoological Gardens, and many others. Everything now, except the skull, and simple bones

of the extremities, are removed from the skin, an arsenical soap, prepared and sold for the purpose, or a solution of muriate of mercury, as used by Waterton, applied to its surface (with the certain effect of preserving it for centuries), and the mode of setting-up, which is totally different, as the slightest comparison will prove. One of the best publications, though that may be improved in some parts soon, is a small work on the art called Taxidermy, that I have met with. Extracts occasionally from which would teach the tyro artist, and youthful amateur, the way they should go, which practice in a little time would perfect, if it is your wish or intention to include the above subjects in the list of your articles treated of.”

HYBRID BETWEEN THE PHEASANT AND FOWL.—*W. L. B.* has obliged us with the following:—“At page 392 you state, ‘a cross between the pheasant and the fowl there never was, nor ever will be.’ I thought so for years, and never succeeded in hearing of one, though many keepers where large numbers of pheasants were raised have told me of their endeavours to hatch eggs of the common fowl crossed by the pheasant. The pheasant cocks readily have connection with the hens, but the eggs, I was informed, always proved barren. Last year, a friend of mine procured eggs from a cottager near a cover where there were pheasants, and from which cover a cock pheasant regularly, for weeks, came to the hens; but, out of more than twenty eggs, none proved fertile. I should mention the cottager had only hens, and I can enumerate other instances of want of success. Last winter, the keeper of Joseph Neeld, of Guttleton House, Wilts, told me, that out of sixty eggs from hens to which cock pheasants had access, he hatched three chickens, which he stated I might see at Guttleton House; but I never saw them, and cannot state this as a fact. I believe, in one of the cases of birds at the Great Exhibition there was a bird of this cross. I saw the bird, and so did others of my acquaintance. If you will refer to ‘Yarrell's Birds,’ vol. ii., page 284, you will see what he says of this cross, and at pages 309–311 you will further see instances of crosses between pheasant and black grouse. Still, as I stated before, though I have for years made inquiries, and have been in the habit of seeing large numbers of pheasants raised by keepers,—still, I never could hear of an instance till Mr. Neeld's keeper told me. I never could hear of an instance in Wychwood Forest, though the keepers all kept fowls in the forest.” Another correspondent (*Scrutator*) writes in a strongly contrasted tone on the same subject:—“In the first place, your correspondent states that ‘there never was, nor ever will be, a cross between the pheasant and the fowl;’ and further, that you might as well try to cross a Shrubland Geranium with a Hollyhock. Now, to a naturalist, these sweeping assertions are particularly disagreeable, when it is well known that these hybrids have been repeatedly exhibited on the table of the Zoological Society, both alive and preserved; and, moreover, one was seen by half London at the Metropolitan show last month. Again, he talks of the merest novice of a hen, agreeably with nature's dictation, assisting at the parturition of the chick, when it is a well-established fact that the mother renders *no assistance whatever*. Let him go and see Cantelo's machine, or buy the Rev. Mr. Dixon's work on Poultry; in the latter he will be taught that the chicken is provided with an instrument, at the end of the beak, wherewith it is enabled to cut its way out. He also talks of Pheasants hatching on or about the 19th day; he never knew any such thing; they certainly vary as to time, but the 23rd or 24th day is early, and the 26th not unusual.”

[Of course, “Upwards and Onwards” is wrong as to the hen aiding the chicken to break the shell. As to the other points, we leave them to the disputant parties.—ED. C. G.]

GLASS FOR GREENHOUSE (Hex).—The furrowed specimen sent by you will do very well for the purpose.

PRUNING YOUNG TREES (A. P. X.).—Your Apricots, Nectarines, and Peaches, planted three months since, should have been pruned at the time. Let it be done immediately.

CUCUMBERS (A Subscriber).—For table purposes, and growing in heat, none are better than the *Brownston Hybrid* and *Ston House*. For out-of-door culture, the common *Short-prickly* for abundance, and the *Long-prickly* for finer fruit. We cannot remember who the party was who subscribed himself “A Subscriber,” at page 261 of No. 199.

MURRAIN IN COWS (A Farmer).—Give them each $\frac{1}{2}$ lb. Epsom salts, 2 oz. of bruised Coriander seeds, and 1 oz. of Gentian Powder, mixed in a little warm water. Keep them in a warm shed. The symptoms will, probably, soon disappear. If not, you had better consult an educated veterinary surgeon.

PANSIES.—Mr. L. Fleming, Secretary of the Eastern Border Horticultural Society, Berwick, would be obliged by “Pansyiana” communicating to him his address.

LEGS OF SHANGHAI FOWLS (G. R., Essex).—Whoever told you that yellow legs in these will never gain a prize knew nothing about the point. Yellow is the colour of the legs of the pure breeds, tinged sometimes in places with red where the skin is thin. The white or blue legged always are avoided.

NAMES OF PLANTS (D. P.).—1, *Asplenium* sp.; 2, *A. diversifolium*; 3, *Blechnum* sp.; 4 and 5, *Doodia caudata*, fertile fronds; 6, *Lycopodium denticulatum* (?); 7, unknown to us; 8, *Adiantum cuneatum*; 9, *Lycopodium flabulare*; 10, unknown to us; 11, *Gymnogramma chrysophylla*; 12, *Lycopodium Galeottii*; 13, *Adiantum hispidulum*; 14, *Lycopodium helveticum*; 15, *Doodia caudata*, sterile frond; 16, *Polypodium* sp.; 17, appears to be a bit of a *Drynaria*; 18, *Pteris serrulata*; 19, *Lycopodium circinatum*. If our correspondent had sent these specimens at three enclosures, and better specimens, we should have been able to have given the desired information more correctly, as many of the specimens sent are too diminutive and crushed for examination; besides, the Ferns exhibit such a variety of forms as they grow on, that a bit sent may not show the real character of the plant it is taken from.

LONDON: Printed by HARRY WOOLDRIDGE, Winchester High-street, in the Parish of Saint Mary Kalender; and Published by WILLIAM SOMERVILLE ORR, at the Office, No. 2, Amen Corner, in the Parish of Christ Church, City of London.—March 3rd, 1853.

WEEKLY CALENDAR.

M D	W D	MARCH 10—16, 1853.	WEATHER NEAR LONDON IN 1852.				Sun Rises.	Sun Sets.	Moon R. & S.	Moon's Age.	Clock bf. Sun.	Day of Year.
			Barometer.	Thermo.	Wind.	Rain in In.						
10	Th	Yellow-horned; paling.	30.382—30.300	46—26	E.	01	27 a. 6	54 a. 5	6 a 34	1	10 28	69
11	F	Orange Underwing; willows.	30.240—30.217	45—34	N.E.	—	25	55	7 44	2	10 12	70
12	S	Light-orange Underwing.	30.382—30.316	49—25	N.E.	—	23	57	8 53	3	9 56	71
13	SUN	5 SUNDAY IN LENT.	30.428—30.371	48—26	E.	—	20	59	10 1	4	9 40	72
14	M	March Moth; palings.	30.422—30.386	48—25	N.E.	—	18	VI	11 8	5	9 23	73
15	Tu	Mottled Grey; heaths.	30.427—30.415	46—32	N.E.	—	16	2	morn.	6	9 6	74
16	W	Large Ingrailed; trees.	30.402—30.348	48—35	N.E.	01	14	4	0 15	7	8 48	75

METEOROLOGY OF THE WEEK.—At Chiswick, from observations during the last twenty-six years, the average highest and lowest temperatures of these days are 50.9°, and 34.1° respectively. The greatest heat, 67°, occurred on the 9th in 1826; and the lowest cold, 7°, on the 10th in 1847. During the period 105 days were fine, and on 77 rain fell.

BRITISH WILD FLOWERS.

POPPYWORDS.—PAPAVERACEÆ.

(Continued from page 395.)

RÖMERIA.



GENERIC CHARACTER.—*Petals* four. *Seed-vessel* long, from two to four valved; the valves opening from the top to the bottom. *Placentæ* distinct. *Seeds* pitted, without a crest.

RÖMERIA HYBRIDA: Hybrid Romeria; Violet Celandine; Violet Horned-Poppy.

Description.—It is an annual. *Root* spindling, or carrot-shaped, but slender. *Root-leaves* stalked. *Stem* erect, about a foot high, branched, cylindric, slightly bristled. *Stem-leaves* stalkless, dark green, cut into many toothed, sharp segments, smooth. *Flower-stalks* terminating the branch, cylindric, one-flowered, smooth. *Calyx* oval, slightly hairy. *Petals* egg-shaped, deep purple or violet, seldom lasting more than three or four hours. *Anthers* twin, pale blue. *Seed-vessel*, a pod two or three inches long, rather crooked, slightly bristly. *Stigma* three-rayed. *Seeds* round, greyish-black, slightly pitted, attached by small stalks to the receptacles in a double row.

Places where found.—Rare. In corn-fields in Cambridgeshire and Norfolk.

Time of flowering.—May and June.

History.—This plant was called *Chelidonium hybridum* by Linnæus, from a suspicion which he entertained that it might be the offspring of *Papaver argemone* impregnated by pollen from some species of *Chelidonium*. Other botanists have named it *Glaucium violaceum*, and others before them *Papaver corniculatum violaceum*. A botanical critic, named Medicus, first separated it both from *Chelidonium* and *Glaucium*, and bestowed upon it the title of *Römeria*, in honour of a German botanist, J. J. Römer, who died Professor of Botany at Landshut, in 1820. Medicus would not have been a sufficient authority had he not been sustained by M. Decandolle approving the new genus. It is common in Spain, but Ray was the first to discover it in England, growing in Cambridgeshire, between Burwel and Swaffham. Like the other Horned-Poppies it has a yellow juice. (Lindley. Martyn. Smith. Ray.)

If we were asked to specify the difficulty in gardening upon which we have most frequently been asked to advise, our reply would be—Upon the most desirable mode of heating a small greenhouse. The causes of this difficulty are various. Hot-water apparatus is expensive; flues take up much room; both are difficult to temper, so as not to overheat a very small structure, and the fire of either requires constant attention, to say nothing about the dirt and trouble of lighting and re-lighting. Where there is a gardener, and no deficiency of assistance, all this is mere matter of customary routine and seasonable duty, but they are grave difficulties, and almost worse than counterbalancing the pleasure derived from a greenhouse by an amateur of limited means, upon whose own skill, or that of the lady of the house, its management devolves.

Last autumn, a principal tradesman in Winchester applied to us for advice upon this very point, and we recommended him to have a small hot-water apparatus

heated by gas. As the expense is not an object to him, he has had the apparatus constructed of copper.

About the same time, we think, a similar idea suggested itself to Mr. Cuthill, of Camberwell, for he communicated the plan to the London Horticultural Society at its last meeting.

Strangely enough, and as if there were certain thoughts had a vagrant habit, and found a resting place in various brains as they journeyed on, Mr. Arthur Paine, wine-merchant, at Tiverton, also in last autumn constructed a similar apparatus. To him belongs the greatest merit, however, for he at once embodied the thought, and in the apparatus, of which we subjoin his drawing and description, little room remains for improvement. The only suggestion we have to make, is that a funnel be attached to a tube long enough to reach to near the bottom of the boiler, and that care be taken that a little water can be always seen in the funnel.

Mr. Paine says:—"I have great pleasure in answering your questions, and am sure, should any of your readers try this means of keeping out frost, they will find it succeed beyond expectation.

"Mine, it is true, is on a very small scale, but I have no doubt it is equally adapted for buildings of a larger size, provided the gas-burner is increased in proportion.

"The boiler is placed inside the house, so that all the heat from the gas and the boiler itself may be made useful.

"It is enclosed three-quarters up with slate and

mortar, so as to allow the heat to ply all round it. I have had it in use since September.

"One-inch lead-pipes are used to attach the boiler to the iron-pipes, on account of being more easily fixed to the boiler than the three-inch iron ones. I should here observe, that I have proved the lead-pipes will not give the same amount of heat as the iron. I have twelve jets of gas in the ring beneath the boiler. The holes being pierced with the smallest drill.

"During all the severe weather in February, and without putting on mats, it maintained a temperature above 45° in a house ten feet long, and seven feet wide."

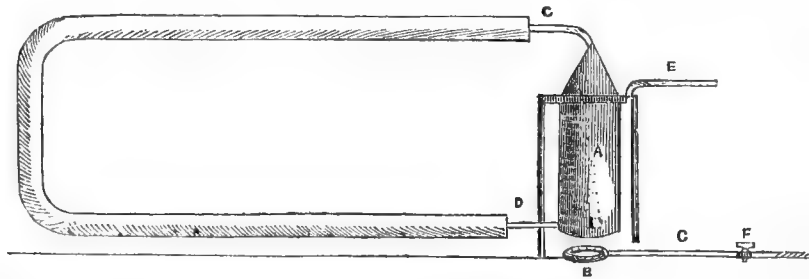

a Three-quat tin boiler.
b Ring gas burner; twelve small jets.
c Flow-pipe (iron) three inches.

d Return do.
e Pipe conducting consumed gas outside of house, one-inch.
f Gas tap.

g Communication from outside of house, to light gas.

WE have now before us the Poultry Prize-list of the *Yorkshire Agricultural Society*, to be held at Leeds in December of the present year.

The judicious limitation for the exhibition of chickens in their own classes only, not suffering them to appear in the pens devoted to their seniors, which originated with the Birmingham committee, has been wisely followed; and every poultry-keeper of experience will rejoice at a decision which will give his birds of either class a fairer field of competition.

In Shanghaes, or Cochin-Chinas, we find classes 24 and 25 allotted to cinnamon and buff, and 26 and 27 are to be filled with brown and partridge-feathered birds. So far, so good; but then follow classes, "white, black, or any other colour." Now, we hesitate as to the correctness of bringing all these into competition with one another. The white Shanghaes have every claim on our notice as a distinct variety, like producing like, and as such should have a class of their own, to which we must consider them fully as much entitled as the numerous families of Game fowls, which have here, as elsewhere, attained that distinction.

At Birmingham, a class has been opened exclusively for black Shanghaes, and the ground, as we presume, on which they were admitted, was that of their title to be considered a distinct sub-variety, as evidenced by the test already referred to. If this is borne out by evidence, their claim should certainly be allowed; but the curious combination of colours, white and buff, on the part of so many of the parents of the black cockerels and pullets of 1852, cannot but raise doubts as to their strict legitimacy.

Now, so far as we know, the white have no charge of this kind brought against them—at any rate, none well

substantiated; and in their native country, as in England, they have given, on the other hand, many proofs of the justice of their claim to be regarded as a pure race, free from the bar sinister. We would not, then, have coupled them with blacks, which hitherto, at least, have not proved their case, nor with the other miscellanies among which they must appear at Leeds.

Game fowl, Hamburgs, and Polands, succeed each other in the usual course, and the prizes are liberal; but our poor little friends, the Bantams, have verily been cut down to a peace establishment; since, all their glories of gold and silver laced, black, white, and sundries, are merged in one, and but one scale of prizes awarded to the whole family.

This could hardly proceed from mere motives of economy on the part of the managers of a society that elsewhere holds forth such tempting prizes; we conclude, therefore, that a desire to call forth *farmer's poultry* must have caused this deposition of our tiny friends. If this be the case, no one has a right to find fault; and a step is taken to assure the public how far "utility" is the principle on which these societies are conducted; but we would have gone a step further when determined to carry out this same principle, and would have divided Geese and Turkeys, those essentially farmer's stock, as fowls are divided into birds of the year, and those beyond it.

We have specially alluded to the case of the black and white Shanghaes, as sufficient numbers of them will, probably, be bred during the course of the present year, to give us more insight into their origin and parentage than is at present before the public.

The *Bath and Western Counties Agricultural Association* have also published their list of poultry prizes

to be awarded at a meeting, at Plymouth, in June next. Chickens, of course, must be of the current year; and what with the present severity of the weather, and the early period of the exhibition, the judges will have full room for speculation as to what the young birds will eventually turn out, when they behold them in the infant state in June. We do not say that matters could have been otherwise arranged, but simply allude to it as one of the many drawbacks of summer poultry shows. These chickens of 1853, which will be, at the most, some twelve or fifteen weeks old, are, we see, dignified by the reverend title of "*cocks and hens*."

The classes for Shanghaes being limited to "*cinnamon and buff*" and "*dark*"—"white" we must understand to be excluded. We must, too, utter some little remonstrance on behalf of the "*gold and silver-spangled Hamburgs*," which are also proscribed; while for the class "*for any other distinct breed*," we have in exchange one for "*silks*"—hardly, we think, an improvement.

"*Hybrids*" are to be honoured; but their class is so placed under the general heading "*Polands*" that any one deriving his information from the prize-list must be led to infer that "*hybrid Poles*" alone are admissible. We shall be curious for the appearance of these highly-favoured top-knots.

But the question of the admission of hybrids at all is one of great doubt; and Birmingham, a good authority, has, as we think, justly excluded them. We should be glad, however, if we are called upon to notice better results from the stimulus thus given than have ever rewarded the careful and scientific experiments of many of our friends, as to the advantages to be gained in cross-breeding fowls. We regret observing that some of the best pigeons are altogether omitted.

The system of post-entry, so fruitful a source of dissatisfaction at meetings of another description is here introduced. We shall be glad to learn what object the committee hope to serve by it. The rules, especially with regard to entries, are not quite so clear as we could wish, nor do we understand the principle on which these entries are to be made. This, it seems, has already been noticed, and to one of our friends who sought for information, the following letter has been addressed by the honorary secretary at Plymouth:—

"Plymouth, 21st Feb., 1853.

"Sir,—Your other questions will be best answered by my observing that our conditions and regulations are to be interpreted *literally*; that the list of prizes, as it stands, is complete, and that it is not intended to add to, or diminish from it in any particular whatever.

"An exhibitor can obtain a prize *in accordance with his entry only*. If he enter, say cock and two hens, for a first prize, he cannot obtain a second or third *with the same fowls*. If the entry be for a second prize, he cannot obtain a first or a third; and so with an entry for a third, the exhibitor on entering cannot obtain a first or a second prize. (Signed) JAMES MULLENY, Hon. Sec.

"Mr. W. C. Pennington, Penzance."

When any society deviates, for the first time, from the

course hitherto taken by other associations established for similar purposes, the public may fairly ask for what object certain unusual arrangements have been effected. Just so in the present case. Birmingham, with the Metropolitan and our other Poultry societies, adopted and acted on the usual system for making the different entries of stock for exhibition, leaving it to the merits of each pen to determine whether a first, second, or third prize should be assigned to it, or whether it should remain unnoticed. The secretary's explanation of the regulations presents some very novel features, the reasons for which we must confess ourselves as yet unable to appreciate. We shall hope, therefore, to be enlightened on these points, and are the more disposed to ask for this information, as such revolutions on the part of so influential a body as this society must have an important bearing on other similar institutions. W.

COVENT GARDEN.

SOME time ago we had occasion to remark on the unsatisfactory state of the metrage of the market, and to expose what cannot be called by any other milder term than the fraud which is practised on purchasers by the irregular measures which are employed in the sale of fruits and other productions. We have, for some time, intended to prepare a statement of these for the benefit of those who may not be acquainted with the subject. To many our reports must have appeared unintelligible, from the strange names of the measures quoted; but we shall now, and on future occasions, notice some of these, until we have overtaken the whole.

THE BUSHEL.—This is, in its integrity, an imperial bushel; but what it is as used in the Garden would puzzle all the meters in London: it is something like the quart wine-bottle—a bushel only in name; for what with the tremendous "kick" in the bottom, and the stratum of straw over it, the Covent Garden bushel rarely ever contains more than three pecks. This is not, however, the fault of the bushel, but that of the inspectors of weights and measures, whose duty it surely is to take proper cognizance of these matters.

The next smaller measure of capacity is—

THE SIEVE.—This, like the bushel basket, is made of wicker-work, and should contain about the same quantity as half-a-bushel, or 1644 cubic inches.

THE HALF-SIEVE is the next in size smaller, and contains 822 cubic inches, or about the capacity of a peck. This also is made of wicker-work. There is also

THE QUARTER-SIEVE, which contains about one gallon.

Besides these there are smaller measures called **PUNNETS**, which are constructed of thin strips of deal, and plashed in the same way as wicker-work. They are of four sizes.

THE LARGE PUNNET contains 248 cubic inches, or five pints-and-a-half.

THE SECOND PUNNET contains 228 cubic inches, or about a pottle.

THE THIRD PUNNET contains 90 cubic inches, or the capacity of a quart.

THE SMALL PUNNET contains 60 cubic inches, or a pint-and-a-half.

We shall return to the subject on a future occasion—possibly next week, when we shall treat of the other departments of this subject.

The continuance of the frost is very much against a liberal supply of VEGETABLES, and the prices, in consequence, remain high. There is, however, a good supply of Asparagus and Sea-kale. FRUIT of all kinds is very scarce; but FLOWERS are abundant. H.

GOSSIP AND GLEANINGS.

WE believe that we shall live until the time arrives when *Paper* will be manufactured from the fibres of almost any vegetable. Those of the Jerusalem Artichoke, Sunflower, Dahlia, and many other tenants of the garden, we think especially applicable to the purpose. There is nothing peculiar in the chemical composition of Flax to indicate that it alone is calculated for the paper-maker's use. Then, as for toughness, Bass matting, and many other vegetable fibres, are equally strong. This, however, is not an essential quality in the material for paper-making, inasmuch as that straw, one of the most brittle of plant-stems, is now successfully employed. The following statement in point is extracted from the *Journal of the Society of Arts*:—"The manufacture of *Straw Paper* was first introduced about fifty years ago, but was only partially successful. By an interesting and important improvement in the mode of preparation, the use of straw as a material for paper may now be considered permanently established in England, Ireland, and the United States. So little difference is perceptible between rag and straw paper, that the latter is used by one of the London journals regularly. One peculiar feature of the manufacture is, that although the article can be produced at a price not exceeding that of ordinary printing paper, it is applicable for both writing and printing purposes."

A Correspondent (J. J.), who sends us his address, says: "I find at page 79 of the present volume, a short extract relative to *Paul Jones*, to which I would beg to refer, and in doing so must say the birth-place of this celebrated pirate was not at St. Mary's Isle, nor was his father ever gardener to the Earl of Selkirk, but to Mr. Craick, Laird of Ardbigland, a small estate in the Stewartry, about twenty-three miles below Dumfries; and if I mistake not, about twenty-one from Kirkcudbright, and situate in the parish of Kirkbean. Mr. Craick was a noted agriculturist, an improver in breeding and feeding farming stock, and an improver of agricultural implements; indeed, the surrounding country owes to him much of its present high state of culture. The cot in which young Paul first drew breath had almost crumbled into ruins, but was rebuilt by the present Mr. Craick (who, I understand, has lately sold the estate), and it still retains the name of "*Paul Jones*"

Cottage," and relics of him and his favourite retreats are pointed out to the stranger. The two summer-houses remain, one on each side of a large folding-door emerging from the garden, within ten yards of high-water mark, on the bank of the Solway. The garden seems about an imperial acre, surrounded by high stone walls, covered with what have been fine old fruit trees, but now much neglected, and it contains nothing very remarkable, save a fine specimen of the Garden Hydrangea, which I saw in full bloom, and bearing about 100 splendid blooms, although not in any season protected. There are there likewise some of the finest specimens of Spruce and Silver Fir I ever saw."

The *Shanghai hen* (lot 102) mentioned by us at page 399, was purchased by Mrs. Newton, Laurel Cottage, Gravesend.

Another of Mr. Stevens's fortnightly sales took place on the 1st instant, and the 200 lots of poultry realized about £443, including a few lots which were bought in. Lot 40. A buff pullet, bred by Mr. George, was bought by H. G. Gurney, Esq., for £15 15s.; and the same gentleman bought lot 46 for £42. It was a buff cock, bred by Mr. Collinson. It was certainly a handsome, brilliant coloured bird, but deficient in size. Lot 48. A buff cockerel, son of Mr. Sturgeon's *Patriarch*, was bought by Mr. English for £5 10s. Lot 65. A buff pullet, bred by Mr. Holt, was purchased for £10 by Mr. Shackell, of Uxbridge. Lot 72. A light buff cockerel, bred by Mr. George, and brother to his *Prince*, was bought by Mr. Wright, of Croydon, for £10 10s. Lot 165. A buff cockerel, of Dr. Gwynne's strain, was bought for £8, by Mr. Fox, of Skinner-street.

The *Winter Exhibitions of Poultry* are not yet all over, for we see that there is to be one on the 18th and 19th of this month at Kendal; and this must come within the class of winter shows. It is, however, much too late; the best hens are getting broody, and both they and the cocks are declining in weight.

We are informed, upon very good authority, that *The Smithfield Club* intend this year to have a *Poultry Show* one week after their own usual exhibition. It is proposed to have prizes for fat fowls, as well as for stock specimens. Its prizes will be on a most liberal scale, and an effort made to render it a national gathering.

PINE APPLES.

I FEEL justified in returning to this subject at this period, on account of the rearrangement generally requisite in spring; and, in this respect, it is very probable some of our readers have got the start of us. Such a pressure of subjects, however, have presented themselves during the last few months, that it was impossible to reach this point sooner.

It has before been stated, that Pines, by the Hamiltonian system, or planted out, do not require a tithe of the labour those do which are under the old pot-system. Let all who wish to be severe in the economy of labour look well to this. Let them just reflect what an important matter it is to a gardener, who is tied to the very minimum point in regard of labour, to have a pinery which requires by far less labour in the aggregate than

an ordinary frame. When a gardener has more on his hands than can be well done, it is surely evident that something must be delayed, or must be omitted altogether; and do not we all know that the proprietor's interest and the gardener's feelings both suffer at once? This shows how important it is to simplify all garden plans; both economy and success are concerned in this simplification.

However, as to POT PINES, I must beg to offer some practical advice applicable to the season. The old tan-bed, after resting undisturbed, or nearly so, since the end of October, will require renewal; this is the first thing to be thought of, and hence the great defect in bottom-heats of fermenting materials; it is impossible thoroughly to renew them without removing the plants; and it is assuredly impossible to effect the latter without rupturing numberless sap vessels. Every practical man will confess how grieved he has felt to hear crack, crack, among the noble and unblemished leaves of his strong successions, when in the act of tying them, if compelled so to do, preparatory to removal. He can no longer feel the same pride in the plants; hitherto he has seen them daily without a deformity; now he is, of course, anticipating decayed points, leaves rotting off in the centre, others half crushed; so that he is puzzled to know, subsequently, whether to entirely amputate them. These are the kind of evils to be faced by the Pine shifter, who generally sets about the work of disturbance with a heavy heart if the plants be very robust.

Mr. Hamilton, however, in his useful book, suggests a plan by which, under some circumstances, this cracking and crushing may be avoided. It is to remove one row at front, and to renew the materials beneath to the very bottom, making a lively heat in this part, which, of course, acts as a lining to the rest, in exciting it to fresh action.

This is by no means a bad plan, although it does not go the whole length of the evil; inasmuch as that portion of the pit farthest from the point of operation benefits but very moderately by the removal. If a pit contains four or five rows, a back row might be removed and treated in like manner; and thus the pit would be renovated, and the removal of a row or two saved.

But for these evils there is no radical cure but a permanent and unfailing source of bottom-heat by hot-water piping. It has cost so much, however, in numberless cases, to fit up such sources of bottom-heat with chambers, tanks, and other superfluous apparatus, that I fear it will take some time to persuade the public that a much simpler plan will succeed—simply, piping buried in stones, as detailed in the papers on the Hamiltonian system.

The early part of March is the favourite period with most for a general rearrangement of their stock of Pines. Early-fruiter in "show" will require the introduction of more tan, and if the body of the bed has become husky it should be watered with tepid water, and stirred deep with a strong stake. Where the tan or other material is getting rather hard-worn, and the plants may not be disturbed, I should advise laying on about four inches of new tan on the heels of the watering; and the operator may now stir so deep and so carefully as to take care that much of this new tan sinks deeply down; this will add new life at a lower level. After this, he may add plenty more new tan on the surface; even covering over the surface of the pots, if necessary, to the depth of three inches. This, well carried out, will produce a genial warmth, which will endure for a long period as the season is advancing. By-the-by, this stirring deep with a stake is excellent practice, and cannot be done too often; it both renews and purifies; those who practice this, and often syringe between the stems of the Pines on the fermenting surface, will not be troubled with nauseous fungi, at

once the produce and the producers of a vitiated atmosphere.

Succession Pines, in pots, heated with fermenting materials, will require a thorough renewal of their heat, if they are to continue through the summer in these structures. Here there is much less difficulty than with fruiting-plants, as the plants are by far less bulky, and, moreover, they must be repotted, if not in their final shift. Those who have other pits at liberty generally prepare one anew for their reception beforehand, and this is the very best plan, as there is time to prove the heat before introducing the Pines.

I may here refer to the repotting process, a thing of the utmost importance; indeed, if this be badly done, all other advantages will be sadly negated. In former days, some of our readers may remember, that even many of the first gardeners of the day insisted on what was termed disrooting them; that is to say, tumbling them out of their pots, shaking away every particle of soil, and cutting away about three-fourths of their roots. This was a strange piece of infatuation, showing plainly the tyranny of mere rule even with first-rate professors; but gardening is not the only art liable to such misconception. Disrooting by system is now entirely repudiated; I doubt if it has one solitary champion left. Mr. Hamilton did much in breaking up this silly procedure, by forcing attention to the great longevity of the Pine-roots, although such, to all appearance, are discoloured and apparently worn-out. It was this singular discolouration through age, I suppose, which misled our venerable predecessors; but a clear observation, coupled with common sense, would surely have shown them the fallacy of disrooting. In those days, however, potting principles, such as the constitution of soils, the importance of thorough drainage, &c., were but imperfectly understood; the riddle was too much in vogue; and in addition, people used to water their Pines in an unnecessary degree in the dormant season. Hence the soil became soured, and roots did, indeed, perish.

Such things do now occasionally happen, and where the roots are in this perished state, no alternative remains but to shake the soil away, trim their roots, and repot them. As to size of shift, there is much less "fiddle faddle" in these days than formerly, when folks were scarcely contented with a Pine plant, unless it had made acquaintance with nearly every sized-pot in the shed, from a five-inch up to a fifteen. What is termed the "one-shift" system, or something closely approaching it, is now very generally practised. A sucker potted in a seven-inch now, will deserve a nine-inch pot before Midsummer, and its final shift in the end of August.

And now, as to soils, or what are termed composts. I do not think anything can excel one of three-parts turfy loam, and the other portion an old cucumber-bed, which had been composed of about equal parts dung and leaves. A little of some charred rubbish yard-materials may be added, to ensure porosity. It is not so much any particular virtue in the soil, or its texture, that concerns most highly the Pine. In point of texture, it should contain the elements of durability, or of keeping long mellow, as gardeners express it; hence the materials should not be too highly decayed. Turfy loam from a very old pasture, in character intermediate between the adhesive and the friable, stacked in a sharp ridge when dry, for six or eight months, is almost complete in itself for their highest culture, inasmuch as extra fertility may be imparted through the medium of liquid-manure. Some of the noblest Pines that I have lately met with, I had the pleasure of seeing in September last, at Alnwick Castle gardens, belonging to His Grace the Duke of Northumberland. Mr. Pillans, his very excellent gardener, takes a just pride in his

Pines, and it is delightful to observe the effects of high culture, based on the well-observed natural habits of this fruit. I was highly delighted to find a thorough confirmation of the views I had long taken, as to the efficiency of sound turfy unctuous loam in the culture of pines. I was delighted, I repeat, not that my views of the matter happened to prove correct, but that a principle was confirmed, about which there could scarcely arise, hereafter, a necessity for recantation.

On examining closely the soil of Mr. Pillan's Pines, I found the soil principally strong yellow loam, obtained, I was told, from Aluwick town-moor. Instead of the surface of the pots being covered in a neatly-finished way, and smoothed down, there were tufts of turfy loam here and there, rising above the mass like so many pincushions; the leaves of the Pines, broad, robust, and milky-green, felt to the touch like some metallic substance. And why? Simply because every sap-vessel was distended with liberal supplies through a vigorous root; the elaborations in Mr. Pillan's houses, metal roofs (requiring shading in extreme weather), being, doubtless, ever a match for the "raw material" from the root.

Equal in importance to the staple of the soil is the mode of potting: a safe and speedy egress for fluids must be provided. Thorough drainage secures this, and more. There can be little doubt, I think, that the cavernous character of the bottom of a well-drained pine-pot is of as much importance in facilitating the admission of nourishing gases to the root, as in providing for the escape of water. Three or four large crocks, placed as hollow as possible, with a little coarse material strewed amongst them, and on this dry turf in lumps, having the mere soil beat out, makes a capital drainage, in depth about one-fifth of the pot.

Up to this period Pines should have been kept tolerably dry, at least, those for repotting; and the operator may water them liberally about a week before the repotting process, by which means the soil will be in an equable state, and what we gardeners term "mellow." The compost being prepared, and in a rather dry condition, abundance of loamy turf in lumps may, in a separate state, lay on the right side of the potting-bench, and these the operator may continue thrusting in constantly as the potting proceeds. One very good plan is, after placing the ball on the turfy lumps which cover the crocks, to thrust in a row of the potting-bench lumps of turf; these latter not having the soil beat out as in the case of the drainage material; then to fill up with the ordinary compost until level with the ball surface, when another layer of the turf lumps may again be introduced, and then the whole coated over two or three inches with the compost. I do not think there can be better practice than this, as far as potting is concerned. The soil will remain fresh and mellow as long as the Pine remains in it, and will permit water and air to traverse it in every direction. I lay much stress on the soil being dry—not, however, dusty—and in that state let the whole be pressed or crammed tightly in with the hand; but on no account should the pot be thumped on the bench—a practice which has been ever productive of much injury.

Thus much performed, the plants should be at once plunged where they may commence growth, without any future handling, beyond the final shifting, or repotting, which will be a July, August, or September affair, according to the character of the plants, and the aims of the proprietor; always bearing in mind, that from six to eight months may be calculated on, by ordinary culture, from the final shift to the "show" for fruit.

Here let it be observed, that a jealous eye must henceforth be kept on what are termed bottom-heats. I do still think it a mistaken view to consider such high permanent bottom-heats as 90° essential. If we are to

follow nature's principles, surely this bottom-heat affair is essentially *relative*. Light is, doubtless, the prime moving power, and all straining of points, without a reference to the amount of this, must ever prove fallacious. *Half-plunging*, where fermenting materials are used, must be resorted to; it is easy to add more in case of necessity. We would have no watering at root for two, three, or more weeks after repotting. They will root much faster, and be in less danger of "burning," whilst the soil is mellow than if adhesive, or swelled with moisture; and no wonder—the heated moisture is not confined, but can rapidly escape at every breathing pore in the soil. The syringe will prove a useful adjunct to good culture; and a free ventilation, and a high afternoon temperature, may be used daily after the middle of the month.

R. ERRINGTON.

BULBS.

(Continued from page 401.)

CYRTANTHUS.

THE two evergreen species of this genus, or rather section of *Amaryllis*, were disposed of in the last article; and the following go to rest from the end of October to March or April, and flower after Midsummer with the leaves on, and so till September, according to the kind, and the time they began to grow in the spring. After seeing how readily the *Valotta purpurea* crossed with *C. obliquus*, there can be no doubt of its crossing with some of the deciduous species, whose leaves and flowers the blood of *Valotta* would much improve; and there is another section of *Amaryllis*, called *Gastronema*, which is as sure to cross in with these as if we had the crosses now before us. Then, if the deciduous character of these *Cyrtanthus* and *Gastronemas* would so influence the *Valotta* side of the breed as to go to rest in winter, as no doubt it would in time, we should possess a new race of summer-flowering bulbs, as hardy (for the summer) as Tulips, and with even richer colours, combined with finer striping than is seen in the *Carnation*.

Any one who knows the flower of *Valotta purpurea* may see, from the short description of the following species and those of *Gastronema*, how easily this could be effected. Hence it is that I put a great stress on the value of the genus *Cyrtanthus*, the bulbs of which are not at all difficult to manage, if the proper yellow loam is got for them, and the right treatment allowed. These bulbs ought to be covered with soil, and not be half-exposed, as we do with *Brunsvigias* and similar large bulbs, because they are very susceptible of injury from damp in winter while they are at rest, and the covering of dry soil saves them much. On account of their permanent fleshy roots, it does not do to shake them out of the soil, like *Gladiolus* bulbs, while they are at rest. They will resent any pushing into forced growth in the spring beyond the temperature of a high airy shelf in the greenhouse. The one called *Ventricosa* in the Dictionary, has never been in cultivation, as far as I can make out; but all the species have the flowers more or less *ventricose*, or bulged out in the middle.

CYRTANTHUS ANGUSTIFOLIUS (Narrow-leaved).—A bad name, as others of them have the leaves still narrower. This is the easiest of them to grow, to flower, and to keep, as well as to increase, for it will seed freely. The flowers are four or five, of a rich orange-red, and they hang down from one side of the scape. The leaves are about a quarter-of-an-inch wide, and purple at the bottom, like those of *Valotta purpurea*.

CYRTANTHUS COLLINUS.—This is a native of the hills near Genadendal, 100 miles east of Cape Town. It is a very handsome kind, with eight or nine crimson, or poppy-scarlet, flowers, and with three leaves as narrow

as the last, becoming very slender and purplish at the bottom—indications of its affinity with *Valotta*. The shape of the flowers, the insertion, and length of stamens, and the relative length and position of the style, are of not the slightest use, as private marks, for determining species, or even sections, in the genus *Amaryllis*, to which all these bulbs properly belong.

CYRTANTHUS ODORUS.—Only four crimson, slightly fragrant flowers, and these not quite so pendulous as is usual. The leaves are much narrower than in the last two; they are linear, or the edges nearly meeting along the back.

CYRTANTHUS PALLIDUS.—Five dull pink flowers, paler above the middle; quite pendulous. Very narrow, dark green leaves, attenuated, or becoming smaller, at both ends.

CYRTANTHUS SPIRALIS.—A very marked species, from the leaves growing spirally, in the shape of a corkscrew. There are six or seven flowers, quite pendulous, and of two shades of yellow, giving them a rich soft tint. From Uitenage, near Algoa Bay.

CYRTANTHUS STRIATUS.—Only three or four flowers, pendulous, as usual, beautiful red colour and streaked with yellow; leaves broader than in any of the other deciduous ones a full half-inch, a foot long, and speckled with red at the bottom. If I am right in considering the shape of a flower as of no value for generic distinctions in *Amaryllis*, what else is to hinder this pretty flower from being a *Gastronema*. That it will cross with that section, I have not the slightest doubt in my own mind; nor that the seedlings will be the prettiest striped flowers among all the bulbs—regular Carnation stripes, in fact. The late Mr. Rollison, the father of that respectable firm at Tooting, used to grow these *Cyrtanthus* beautifully; and Mr. Carter, of Holborn, has them often on sale from the Cape growers. They are natives of the eastern territories of the Cape of Good Hope, and so readily known by their coral bells hanging from the top of the stem, that a common shepherd might be entrusted to gather them in his walks.

DAUBENYA.

DAUBENYA AUREA AND FULVA.—Anybody who remembers the very curious bulbs that were named after Masson, the botanical traveller in South Africa, will have no difficulty in recognising these two no less curious plants; and, as far as gardeners are concerned, there is not the slightest difference in the management of these from that necessary for the old *Massonias*; indeed, the colour of these flowers, and those of *Massonia* being bell shaped instead of tubular, and marked with honey pores inside, are the only points of difference, or private mark, between *Daubenia* and *Massonia*. The two genera are only fit for botanic gardens. The leaves are very handsome, dark green, thick, and shining, not more than three inches long and nearly as broad. When full grown, they look much like the leaves of *Hæmanthus coccineus*; when half grown, they fall on each side the same way; then an umbel of flowers comes out from between these two leaves, with hardly a stalk, and the bunch of flowers looks as if it was held by the closeness of the bottom of the leaves; the first one has yellow flowers, the second tawny ones. The bulbs require the same kind of treatment as the *Brunsvigias*.

DIANELLA.

These are also very old-fashioned herbaceous plants, with grassy leaves, and spreading panicles of small blue flowers of different shades, and tuberous roots, looking very much like bulbs, and as such are recorded in our books. They are excessively pretty little things, and as easy to manage almost as Crocuses; but they are out of fashion. The great Horticultural Societies have banished all the best of the old-fashioned plants

from cultivation. There is no great good ever effected without some evil or hardship felt in some quarter or another; and these New Holland Diana Lilyworts had to retire to give place to such things as *Gloriosa superba*, and things that are neither superb nor glorious. Any light sandy loam will grow *Dianellas* of all sorts; they will also grow well in peat; and flower for a long time in summer. They seem to fill up the corresponding space in New Holland which the *Conanthers* do in South America, and there is a great general resemblance between the two families, only the Americans are bad to grow—these the reverse.

DRIMIA.

This is another congregation of old-fashioned Lilyworts from the Cape, but no one grows them now, and they were never worth much out of botanic gardens; but they will grow and flower in any light soil. *Ciliaris*, *lanceifolia*, and *purpurascens* are the best of them; but they are now very scarce, and seldom met with.

ECHEANDIA.

ECHEANDIA TERNIFOLIA, *alias Conanthera echeandia* and *Anthericum reflexum*.—A small, yellow-flowered tuberous-rooted plant, a native of Mexico, whence it was obtained by Sir Charles Lemon, with whom it flowered in 1837 for the first time. It is only botanically interesting.

ELISENE.

ELISENE LONGIPETALA, *alias Pancratium ringens* in the "Flora Peruviana." *Pancratium* and *Hymenocallis* come so close to each other in the first-described species, that no one could tell which was which in the absence of the seeds, and each of them has branched out into sections so very different in aspect as to have often deceived the most learned fully as much as ever *Amaryllis* did; and here is the very last example that I can call to mind of the description of what appears on the face of it to be only a well-marked section of *Ismene*; this *Elisene* is not farther removed from *Hymenocallis* than *Ismene*; and I am quite sure, as far as one can say in the absence of facts, that both of them, with several other plants that are now held by botanists to be distinct genera, will be proved, in the long run, to breed together, and with *Hymenocallis*—thus exemplifying the adage, that the first idea and the last one are sure to be right. The first idea was, that all the lily-like flowers with the nectarian membrane were *Pancratiums*; now we begin to see that *Pancratiums* are very limited indeed, and that nine-tenths of the *Pancratioid* plants must ultimately be arranged under *Hymenocallis*.

Elisene longipetala is one of the handsomest bulbs related to *Ismene*, and, like it, is a native of the Peruvian Andes. The first time it flowered in this country was in 1840, at the end of March, after resting all the winter. The flower scape was a yard high, and carried six large white flowers, whose divisions, or petals, were much longer than is generally seen in allied bulbs; hence the name. The first is an ancient name of romance—a celebrated beauty. No bulb can be more easy to grow than this, if it gets a complete rest for four or five months in winter, and is planted in pure sand, like the old Peruvian Daffodil, *Ismene Amancaes*. After flowering in the spring it ought to be planted out-of-doors about the end of May, like the *Jacobæa Lily* (*Sprekelia*), where it will grow with great vigour till the end of September. On the first appearance of frost it ought to be dried; exactly the same kind of treatment as one would give to *Sprekelia formosissima*, except that it must have a potful of sand to flower in, and a large quantity of sand put under it in the border, and the roots must be preserved in winter as well as the bulbs. A cross between

this and *Chovetis glauca*, or *Ismene calathina*, would be a treasure, as either of them would render the breed of *Elisene* later in flowering, so as to come in the open ground with us; but for a hardier constitution cross it with *Ismene pedunculata*, judging from what has been revealed in the "Vegetable Kingdom," and I think I know as much about that as any one. I am quite sure that "A. S. W.," who has written on the cross-breeding of fowls, has got the right end of the story—analogy can go no farther—experience must do the rest; but it must be done as he says, else stamens and cockerels pull in opposite directions.

EUCOMIS.

The bulbs belonging to this genus are all from the Cape; they are as old as the hills, and as well-known to old gardeners, like me, as Crocuses or Tulips. When we were all young this was one of the commonest stove plants we had to water; after that they turned out to like the greenhouse better; and, last of all, they are found to do out in a border, close under the wall of a greenhouse, or, better still, the front wall of a stove. Mr. Jackson, of Kingston, like me, is very fond of the old Cape bulbs, and of bulbs in general; both of us worked very hard in our younger days, and now we can spare half-an-hour occasionally to talk about old things, and ways; and, in our very last conversation, the bulbs under review were the subject of the story. He has many of them in front of his houses, and some almost out of the ground by over-growing; but the frost never hurts them so far as to keep them from flowering every year. But, to begin with young bulbs of them, they ought to be planted four or five inches deep, and to have a good portion of sand all round them, as the skin of the bulbs is very soft and tender, so that wireworm, and other grubs, like to feed on them. The flowers are not very showy nor striking, and I shall, therefore, occupy no space in describing them individually. They are hardly worth while growing in pots, except it be for their leaves and spotted leaf-stalks. In the eyes of a gardener they are of the same value as the *Hemantus* family.

EUCROSIA.

EUCROSIA BICOLOR.—This is not a very striking bulb, yet the natural colour is much better than it is represented in any of our books; but I hardly know to which to liken it in any of its parts. The leaf is different from that of any other bulb I know—three or four inches long, nearly three inches broad in the middle, and tapering to both ends; the flowers are vermilion, with dark lines, and looks as if it was taken from the umbel of some fine *Alstromeria*. There was a large importation of it once to "Lee's Nursery," and Sweet told them it was a native of Cape Horn, and so they left the pots in a cold frame that winter, and every one of the bulbs were killed. Its natural locality was not determined till 1836, when Dr. Jamieson found it at an elevation of 1000 feet, "on the descent towards Jaguachi," in Peru. It likes strong loam, greenhouse culture, and rest in winter.

FERRARIA.

The *Ferrarias* were never great favourites with any one, owing to the very short time each flower keeps open, and their dull colours. *Cypella plumbea* is better than any of them, keeps longer in flower, from June to August, and has the charms of novelty and the novel colour, lead colour, to the bargain; yet no one grows it. *Ferrarias* require exactly the same treatment as *Ixia*, which see. The three best of them are *antherosa*, *atrata*, and *undulata*.

FOURCROYA

FOURCROYA GIGANTEA and *LONGÆVA* are not bulbs, but large plants between bulbs and American Aloes, with

flower-stems which rise higher than the American Aloe, and they flower only once or so in a life-time, and are fit only for botanic gardens, where all the gardeners know more than we can tell them in our quiet homely way.

GALAXIA.

By cutting short the remarks about such bulbs as this, that are really not worth much, or about which there is really very little chance for improving them, I shall have the more room to say all sorts of things about those which deserve our care and philosophy. *Graminea* and *versicolor* are the only two worth potting in this genus, and they are rather shy—the bulbs perishing often, without one knowing why. Very sandy peat and *Ixia* treatment suits them best.

D. BEATON.

(To be continued.)

JOTTINGS FOR THE GREENHOUSE IN MARCH.

Air giving.—In fine, mild weather, give air rather freely during the day, when the external atmosphere in the shade reaches 45°. Give a little merely at the top, when it is very windy, or cold and frosty. If frost and wind, or either of them exist in unison with a bright sun, it will be preferable to lessen perspiration, by slightly syringing the foliage in a forenoon, taking care, however, that the leaves are dry before the evening. This, and a low temperature in pipes or flues, are preferable to much air in such circumstances, and when an extreme of cold, and an extreme of sunlight come together—as they often do in spring—the slightly shading the house will be of great advantage, especially if the extreme cold and light have been preceded by dull weather. The drier and colder the external air, the greater the care required in admitting it among blooming and vigorously-growing plants. When plants are comparatively in a state of rest, and it is desirable to retard them, they must be kept by themselves, and more air given them. It will not be advisable, during the month, to leave air on at night, as a warm evening is frequently succeeded by a bright cold morning. Even in fine weather the house should be shut by three or four o'clock in the afternoon, and when very cold, a couple of hours earlier. There is little danger of plants drawing from having been shut up with sun-heat, if you allow the house to fall low enough in temperature during the night.

Temperature for growing and flowering plants—night, 43° to 46°; day, with sun, 55° to 65°; for plants resting and being retarded, from 5° to 10° less, according to their hardiness.

Achimenes.—The scaly tubers of these will keep safely in earth in any place where they will have an average temperature of from 43° to 50°. If kept in paper, in drawers, &c., they are apt to shrivel up; the earth prevents their drying. It matters not whether they are kept in the pots in which they grow, or in pans or little boxes, in less space, with plenty of dry earth or sand about and around them. If a supply is wanted, the transmission of sound tubers will involve less risk and trouble and expense than young plants. The last days of the month, or the beginning of April, will be a good time to introduce a few tubers at the back or front of a cucumber-frame or pit, or where there is a temperature of from 55° to 70°. Place the roots in light sandy soil, and in shallow pans, or in pots filled three-parts with drainage. The tubers should be no more than just covered. If the soil is moistish that will be sufficient. Little water will be wanted until the tops of the plants show themselves. If your tubers have got dried, it is better to allow them to absorb slowly from soil more dry than wet, or from moss just damp, than to deluge

with water, as that very likely would ensure rottenness and death.

Acacia.—Of this large genus, perhaps few are superior to the old *Armata*, and the newer *Grandis*. The former will want a good supply of water now, and weak manure-water will bring its golden flowers out in fine perfection. Old plants are sometimes seized upon by a white scale, and in such a case, cutting it well down, and scrubbing it with soap-and-water, and putting the plant in a warmish place to make fresh growth, are the best remedies; or a young plant may be substituted. *Grandis* will now be showing its myriads of buds, and it will like a little manure-water by-and-by, but not strong. One handful of soot and half-a-handful of lime would be strong enough for six gallons. One ounce of guano would do for four gallons. Very strong drinks are as bad for plants as animals. Firm side-shoots, about three inches long, taken off in May, cut to a joint, one-third of the leaves removed, and then inserted in silver sand under a bell-glass, will soon make young plants.

Azalea indica.—These are some of the most useful of our winter and spring plants. The best of ours will soon be over, just because we should have no one to look at them in May. When once induced to bloom early they will come early again with little trouble. Our treatment *now* of these plants must be regulated by the state they are in, and what we expect from them. If in bloom, or showing bloom, an average night temperature of 45° will be requisite, with from 10° to 15° rise from sunshine. Those we wish to bloom in April and May should have more air, and will want little fire heat if the temperature does not fall at night below 40°. Those we wish to retard until June should not only have abundance of air, but we must contrive a situation for them on a north aspect, where they can be defended from wind, sun, and rain, by the beginning of May. The growing and flowering plants will require most water, and *very* weak liquid-manure should at times be given them. See that the water is soft, and a few degrees warmer than the house temperature. Water in the forenoon. Avoid allowing the plants to get dry, or they will shed their leaves. In the case of late-flowering plants, even when water at the roots is not necessary, a syringe over the foliage, in a sunny day, will do them good. Early-flowering plants will be pushing their shoots. If a few should come strong and prematurely, as respects the general crop, pinch out the top when an inch-and-a-half or two inches in length, and you will get two or three of more moderate growth instead. Azaleas may be easily kept in all these different conditions in one moderate-sized house, if arranged in groups in different places, so that the quantity of air and heat may be varied.

Propagation of Azalea indica: by Seeds.—These may now be sown on the surface of pans, well drained, on sandy peat, and placed in a moist temperature of from 55° to 65°. The seeds should just be dusted over with a very little fine sandy peat; and if the pans were well soaked previously, and allowed to drain before sowing, and then a square of glass put over the pan, and covered with paper, little water will be wanted until the young plants appear. They must then be placed near the glass, and hardened off by degrees. *By Cuttings*.—The time to do this will depend upon the time you grow and bloom, at least with most sorts. All may be thus propagated. When the young shoots are from two to two-and-a-half inches long is the best time. Cut them across with a heel, or just where the old and young growth meet. The base of the cutting will thus be *firmish*. Remove the lower leaves for about one-third of the length, and insert in silver sand, above sandy peat, the rest of the pot, for fully three-fourths of its depth, being filled with drainage.

Water, and, when dry, cover with a bell-glass; shade, and place in a temperature of from 55° to 65°. Edge the glasses after a few days on one side at night—say for a quarter-of-an-inch at first—and place it firm on in the morning. Water when necessary. When rooted, give more air by degrees, until they will stand in a greenhouse or cold pit. *By Grafting*.—This is done chiefly with weakly-growing and tender and scarce kinds. The stocks generally used are those of the white *Indica*, and the purple *Phœnicea*. The stocks may be used when strong enough for the knife, though little would be gained by grafting before they were at least two years old. Many methods are adopted by different practitioners, but we cannot describe them to-day, and there may be less necessity, as the principle is the same, the great point being to effect a junction between the inner barks of the scion and the stock. For bush plants, the junction should take place as near the collar of the plant as possible. A small piece of wood and bark is there removed from the stock, and an equal portion from the scion—so that the inner bark on one side, at least, or both if possible, will fit, when they may be tied together with worsted or bass matting. If there should be an horizontal cut at the base of the stock, but not more than one-half or one-third across, or even a notch for the reception of the scion, it will be held firmer, and the union afterwards will be less perceived. A few other desirables may be mentioned: 1st, The stock should be in advance of the scion in growing power. 2nd, The scion should be, for small plants at least, a well-ripened piece of last year's wood, chosen *BEFORE* the growth for the present year has commenced. The size must depend upon what you can get—one bud would do, two would be better; one at the base of the scion, the other near its point; but a piece from two to three inches in length would be better still. 3rd, A nice sweet hotbed, of from 55° to 65°, will be necessary in which to place the plants, and so as you can keep them close and shaded. You may grow anything else in your bed, and give air, provided your grafted plants can be kept close and shaded under a hand-light. 4th, After a few days the extra heat will cause the top of your stock to grow freely, and then you may begin to pinch the points of the most vigorous shoots. As the scion shows signs of growth, the snubbing of the top of the stock must be persevered in, until ultimately it is taken clean off above the scion, and that forms the plant. By that time it will have been hardened off by degrees. 5th, By a similar process you may cover the whole of a large plant that does not please you with scions of one or of many kinds. You could not, however, easily get such a plant into a hot-bed, and even a hothouse would be rather open for it; but after watering the parent plant you might lay it down on the bed, and cover the grafted parts with moss. I have seen the same thing done in a vinery with large plants; but the plants were laid down, a shade secured for them, and a little damp moss kept upon the grafted parts.

Insects.—The Green-Fly is easily managed with a puff of tobacco smoke. Thrip, when it does come, is the bane of the *Azalea* grower. Smoke from shag tobacco, persevered in, may kill it. The best remedy is a close moist atmosphere at growing time, and where there are water-pipes and water-plate, you can raise sulphur exhalations. Another help is sulphur-water, but only half as strong as recommended for Vines last season. Another is laurel-water, made by bruising half-a-gallon of laurel-leaves, pouring water almost at boiling point over them, allowing it to draw like tea; then, when cool, pouring off the clear, and adding water to make five gallons, or rather better. When using both these last the plant should be laid in a reclining position, so that the mixture does not go into the soil; and the liquid should be forcibly thrown on the lower side of the leaves by the syringe. Replace

the plants, and shade, and in a day or so syringe in the same manner with clear water.

To save repetition, I may say, that exactly the same process may be adopted with *Camellias*. They, likewise, when grafted, will grow quicker when indulged with the moist heat of a sweet hotbed. Well ripened wood of last season must also be used. If cuttings should be preferred, every bud of these ripened shoots will form a cutting. Any *Camellia* stock will do for grafting *Camellias*—the single red and the double white are generally preferred. In watering, the plants will like stronger water than would suit *Azaleas*—such as we spoke of for *Acacia*. More will be said of them under a greenhouse-vinery before long.

Balsams.—The man who grows fine bushy Balsams, covered with bloom, will not fail in anything he fairly sets his mind upon. The difficulty is just to give them the position they want, for though they will stand a temperature in a hotbed of from 60° to 70°, when they are vegetating, and until six inches in height, an average night temperature of 50° would suit them better after that, and abundance of air during the day, and even a little at night. The best plants ever I saw were growing in a sheltered place, out-of-doors, in September. They were planted out in June, from seeds sown in the end of April. To have plants in bloom in June and July the seeds must be sown now. When wanted at the end of July and August it will be time enough to sow three weeks or a month hence. There are two ways in which we like to see them. First, as single stems, with a few short side-branches at the base, and covered from that base to nearly the summit, with large flowers. By this mode they bloom earliest; the chief thing, in addition to requisite shiftings, being the thinning of the bloom-buds. Secondly, in *bush fashion*. This requires more time, and the sacrificing of the early buds to encourage side-branches. In both cases, to save disappointment, I prefer keeping the plants in very small pots until the first flower expands; the bad ones are then thrown away. The whole of the flower-buds are picked from the good ones, they are then shifted, and everything done to encourage the *growing* versus the *flowering* principle. When growth has nearly reached its desired limits, we check it by more air, and, if possible, less watering. For the first potting, use light sandy soil, with a little leaf mould. In successional shiftings, increase the richness of the compost, until at last it may consist of nearly half two-year-old, well-decayed and dried cow-dung.

Cockscombs.—These require more heat than Balsams. They will enjoy a bottom-heat of from 75° to 80°, and an average night temperature of 65°, until the combs are nearly fully grown. For early combs, seeds should be sown in February or January. From seeds sown now large combs could not be easily obtained before the middle of July. In sowing the seeds, use sandy loam, and just cover, and no more. It will be advisable to place a bell-glass, or a square of glass over the pot, as several insects are excessively fond of them just when forming the seed-leaf, and good seed is generally scarce. I have frequently hunted over splendid combs without finding a single seed. To save room, and future disappointment, as soon as they can be handled, I prick the seedlings out in shallow pans. This soon causes them to show flower; and you can easily judge, from its incipient state, what its future shape and colour will be. The best are then potted in small pots first, and then into larger as soon as they want it, increasing the richness of the compost as the size of the pot increases. A ten or a twelve-inch pot will grow a very handsome dwarf plant, with a large comb. When tall plants are desirable, they must be grown on from the first, and receive no stunting, either in pans or small pots, to cause them to show their bloom prematurely.

Insects.—There is little annoys either Balsams or Cockscombs, but the fly will sometimes attack them. A little tobacco smoke is the remedy. Fine green foliage sets off both tribes, and especially the latter. Great care, therefore, must be taken of any confined steam, and more especially if the sun should shine on the plants before it is dispersed. A blotched leaf would spoil the look of the finest Cockscomb. The remedy is, give air early, or leave a little all night.

I find I cannot overtake all these jottings in one paper; allow me, in conclusion, to put in a few mere reminders. *Calceolarias*, to bloom in April and May, must have their last shift without delay. The soil should be light and rich: an eight-inch pot will grow a nice specimen. Night temperature from 45° to 48°, and slight shade in very bright sunshine. *Cinerarias* in bloom, and coming into bloom, give manure waterings to them. Give immediately the last potting for those to bloom in May. Neither of these will stand so much dry air as *Azaleas*, and other hard-wooded plants. In bright days the shelves should be kept moist, and even the foliage syringed, provided there are no burning spots in the glass; if there is, shade instead. *Epacris*, done flowering, require to be pruned back, and all the decayed flowers cleaned off, and the plants set in a warm place until they make fresh wood. *Hard-wooded* plants, as a general rule, give most air to, and be careful neither to starve them for want of, nor saturate them with too much moisture. *Heaths* the same; prune back those done flowering; let the others have the airiest part of the house. *Geraniums*, scarlet, pot, and bring into light, from their winter quarters. *Fuchsias*, prune back, preparatory to potting. Give young plants of last season a gentle heat. Cuttings of young shoots will now soon make plants if placed in a hotbed. Like the Scarlet Geranium, the Fuchsia may be grown on in a cool temperature, or during the first stages of growth it will stand nearly as much heat as a cucumber uninjured. *Pelargoniums*, train out the forwardest; shift the second advanced, which will bloom in June; stop the shoots of a third lot, to be shifted three weeks hence, to come in July. *Ixias* and *Gladiolus*, pot late kinds; give more room, air, and light to those growing. *Japan Lilies*, and others, fresh pot as soon as growth commences. *Hotbeds*, make for starting plants, sowing of annual and other seeds, and for grafting and other purposes; and avoid extremes of heat and cold, shade and sunshine.

R. FISH.

THE PELARGONIUM.

(Continued from page 424.)

SUMMER TREATMENT.—The young plants intended for exhibition having been potted and tied-out, as described in my last paper, they will require constant attention in watering, giving air to, and keeping clear of insects. Water should be supplied freely whilst they remain in the greenhouse, because the sun and air will soon dry the mould in the pots. A degree of dryness is essential to the well-being of not only *Pelargoniums*, but all other plants not aquatics, just on the same principle that to be an hungered is essential to the health of an animal, even the human being. To be always watering, whether the plants require it or not, is sure to induce sickness, and yellow leaves, and ends in death. The direction, then, to water freely, implies that the plants require it to keep them growing and in health. As frequent waterings with pure water will, in time, carry off the nutritive powers of the soil, it will be advisable, when that is so, to give a watering with liquid-manure, which not only feeds the plant at that time, but renews, partly, the nourishing power of the soil. Let the amateur bear this in mind, and use this liquid food every

third or fourth time he waters his plants. The most stimulating liquid-manure is that made with guano: half-a-pint of this powerful agent will be abundance for a gallon of water. It should be mixed with the water at least six hours before using; but as every amateur cannot procure guano conveniently, very excellent liquid-manure may be made with various manures. When I was a grower of the Pine-apple I used the following ingredients:—A peck of fowls' dung, a shovelful of soot, and a quart of quick-lime, all mixed together in ten gallons of hot water. This mixture was well stirred amongst the water, and set out-of-doors to cool and settle. The soot and lime killed all sorts of insects that might be in the dung, and also any worms that might be in the soil in which the Pines were growing—indeed, I was seldom troubled with worms after the first application. The liquor, when cooled and settled, was of a rich brown colour, and caused the plants to grow finely, and produce broad leaves of a dark green healthy colour. This kind of liquid-manure anybody may easily make, the materials for it are so plentiful in almost every locality. Where fowls' dung cannot be obtained, then procure sheep or horse-dung; but these should be allowed to stand in the water for a day or two before using, to macerate the dung completely in it, stirring it up frequently, so as to abstract all the ammonia, and other nourishing ingredients in the manure. Care must be taken not to use it too strong; it is better to be rather weak than otherwise. In very hot sunshine the paths and walls of the house should be flooded with water, to keep up a due supply of moisture in the air. In the evening of such a day the plants will be greatly benefited by a gentle shower from the syringe.

Air is one of the indispensable elements for these plants. It should be given unsparingly, whenever the outside atmosphere will admit of it. In the warm months of May and June a little air should be given even during the night.

Insects.—The insect most troublesome to the Pelargonium is the green fly, or aphid. This is easily destroyed by tobacco smoke, but it should not be too strong, nor ever allowed to break into a flame. The leaves at this season are young and tender, and, consequently, liable to be scorched. Five minutes' neglect in this particular would so injure the plants, besides rendering them unsightly, as would take months to repair the mischief. It is much safer to smoke the house gently two or three times on consecutive nights than to run the risk of burning the leaves by too strong a dose of smoke at once.

The House to grow specimen Pelargoniums in.—Whoever intends to compete for prizes should devote a house entirely to these plants. A lean-to or shed-formed house will grow them pretty well. Mr. Turner, of Slough, and Mr. Bragg, of the same place, grow their specimen plants in houses of this form; but they have a considerable amount of trouble in turning the plants round frequently to keep every side in full foliage. If this was not done the plants would be one-sided. And the amateur who has no choice, but must grow his plants in a house of this form, should turn them round at least once a week, especially after the blooms make their appearance. Even with this care the plants cannot make such handsome perfect specimens as those grown in a house of the form I am about to describe. This house will be perfectly understood at once when I mention that it is a span-roofed one. In a house of that form, and of moderate width, the plants grow on every side alike, and the colours of the blooms will be greatly heightened. The roof should not be at a sharp angle, but rather flat than otherwise. There should be a centre stage, just wide enough to hold three rows of plants, one row in the centre, and a row on each side, placed in the alternate spaces between the central plants.

The grand point to attend to is, never to have the plants crowded; *each should stand quite alone*. If they grow so large as to touch each other, one or two must be sacrificed to make room for the rest. A walk of sufficient width should run round the stage, and next to it a platform next the front windows will be very useful. On this platform young plants may be grown, or a row of the dwarf fancy varieties. This platform is not indispensable. The house should be heated with hot-water, with sufficient piping to keep out the frost in the severest winter.

T. APPELBY.

(To be continued.)

CONIFERÆ.

2ND—SECTION OF PINUS, WITH LEAVES THREE IN A SHEATH.

(Continued from page 404.)

PINUS LONGIFOLIA (Long-leaved Pine).—Very properly named *long-leaved*, for the leaves are often a foot long, and hang down gracefully from the branches. A Nepal species, but rather tender, requiring, north of London, the protection of the greenhouse or conservatory. In its native habitats it attains a great size, reaching often fully 100 feet high. In the southern counties, and also in Ireland, it has braved successfully the winter's storms, and is such a graceful tree that it is worthy of every attention to preserve it, should an old-fashioned winter come upon us.

PINUS MACROCARPA (Broadly-hooked Pine).—A noble, handsome tree from California, where it grows from 80 to 100 feet high. The most remarkable distinction in this species is its cones, which are very large. Its scales are four inches long, and nearly as broad at the base; and each scale is furnished with a strong hook—hence its English name. The leaves are long, and of a greyish hue when old; but in a young state have a rich violet bloom upon them. As it is quite hardy, it should be planted largely as soon as the price is moderate. The timber is said to be of excellent quality.

PINUS PATULA (Spreading Pine).—This has been supposed to be too tender to bear our climate, excepting in some favoured spots and in Ireland; but our readers will recollect that I described a fine specimen I saw in a garden near Northampton. That plant had been planted about seven years, and had had no protection, yet it was perfectly healthy, and had never suffered from frost. As it is a most elegant, light, aerial looking tree, it is worthy of a more extended cultivation. It is a native of the Real del Monte, in Mexico, and grows 60 to 70 feet high. There is a variety with the foliage erect, but I never saw it.

PINUS PONDEROSA (Heavy-wooded Pine).—There is a considerable resemblance in this tree to the *P. pinaster*, the difference consisting in this species growing quicker, the leaves being longer and the wood much heavier; indeed, it is so heavy as to sink in water. Then the buds are sharp-pointed, and do not exhibit any resinous exudation. The branches are in whorls round the stem, and when of a considerable size droop at the ends. The leaves are not so persistent as in most other Pines, hence they only clothe the ends of the shoots, giving them a tufted appearance. Its great recommendation is that of being a remarkably handsome tree, and as hardy as the common Highland Pine. It is a native of the north-west coast of America, where it attains the height of 100 feet. Every Pinetum of any magnitude should have one or two of this fine tree, but on account of the great weight of the branch it should be sheltered from the strong west winds.

PINUS RADIATA (Radiated-scaled Pine).—Mr. David Don has so-named this very handsome Pine; but Mr. Hartweg considers it only a variety of *P. insignis*, to which

it is very nearly allied, differing from that fine species chiefly in the size of its cones, and the scales radiating from them. The leaves, like *P. insignis*, are of a dark rich green, numerous placed on the branches, but of a more slender habit. Mr. Hartweg found it in California, growing close to the sea-side, with a stem straight and tapering, 100 feet high, and clothed with branches down to the ground. The timber is said to be excellent for ship-building, being very tough and elastic. Proprietors of estates on the sea-coast should plant this valuable and handsome tree liberally, both for its beauty and the excellence of its timber.

PINUS RIGIDA (Rigid Pitch Pine).—A useful tree, producing great quantities of the pitch of commerce. Its upright, stiff habit renders it not very ornamental, yet it is a fine tree, and very hardy, being a native of New England, in America, where it grows from 60 to 70 feet high.

PINUS SABINIANA (Mr. Sabine's Pine).—There are several fine specimens of this noble tree in this country; one, in particular, is growing in the Chiswick Gardens, probably planted by Mr. Sabine himself. It is now more than forty feet high, with branches spreading down to the grass. Another fine specimen I mentioned in my report of a visit to the Rolleston Gardens, belonging to Sir Oswald Mosely. This species resembles *P. macrocarpa*, mentioned above, but its leaves are larger, being often a foot or more in length. The cones are oval, produced in clusters, and remain on the branches for several years. It is, in its native woods in California, a magnificent tree, frequently rising to 150 feet in height, with a trunk twelve feet in diameter. The branches, when the trees stand apart, clothe the stem down to the ground. Mr. Loudon says, in his "Arboretum Britannicum," speaking of this species and *P. macrocarpa*, "Both species may, indeed, be described as of surpassing beauty; and what adds greatly to their value is, they both appear to be perfectly hardy." Since his time this fact has been proved beyond a doubt, and, therefore, they ought to be planted largely, both for their beauty as ornaments to the Pinetum, as well as for their valuable properties as timber-trees.

PINUS SINCLAIRIANA (Mr. Sinclair's Pine).—So named by Sir William Hooker. Found on the hills of Monterey, in California, but very little is known of it.

PINUS SEROTINA (Late, or Pond Pine).—Native of New Jersey. A low growing tree, seldom exceeding 40 feet high. It is not very ornamental.

PINUS SINENSIS (The Chinese Pine).—A rather tender species, not much known.

PINUS TÆDA (The Frankincense Pine).—A fine tree, native of Virginia, scarcely hardy enough to bear our climate. It is very rare.

PINUS TEOCOTE (Teocote, or Twisted-leaved Pine).—This is a curious species, with the leaves twisted like a cork-screw, rendering it very remarkable. Requires the protection of the conservatory north of London. It has been found hardy in Devonshire and the north of Ireland. It is a native of Mexico, on the Real del Monte, where it attains the height of 50 feet.

T. APPLEBY.

(To be continued.)

A CHAPTER ON HERBS.

It often happens that some remote corner is devoted to the growth of the various scented or culinary plants, called, in gardening phrase, "herbs," or "sweet herbs." That their importance is not such as to entitle them to a place in the front ranks may be easily guessed at, by the neglect which all but universally befalls them now; and though we do not urge them further into notice than the tastes and wants of readers may think best, yet we

advise a little more regard to their welfare while they are expected to grow and conduce to our use and pleasure. And remote and unheeded as may be their abode, yet it not unfrequently happens to come under the eye of the scrutinising visitor, who may, in the culture, see a something to find fault with here, which he looked for in vain elsewhere; weeds struggling with the legitimate crop for the mastery, and, in some instances, having absolutely appropriated to their own use the space which was once a bed of Peppermint, Pennyroyal, Chamomile, or some other plant which wants renewing every year or two. Now it is not my purpose to urge that the occupants of this department ought to be placed on the same footing as Celery, Onions, or Peas; but, in their subordinate capacity, much may often be done to render their appearance more agreeable, as well as to make them more productive. And, in the first instance, I will admit that they only deserve a "second class" situation, and shall suppose they are already located in one; which, however, they may have been occupying for many years, with only the little assistance of now and then filling up the beds with slips of new plants, or, it might be, layers or rooted offsets of the same, planted on exactly the spot whence an old plant was removed, having either died there, or become useless through age. Now it is vain to expect a vigorous growth of any plant stuck in immediately on the spot where another of its species had abstracted all the fertilising properties of the soil required to support it, leaving the soil robbed of the essential ingredients of which the next occupant will be likely to be as much in want of as its predecessor. This principle, which has been advocated for many generations by all writers on horticulture, and agriculture also, is not, in every instance, carried out in small things to the extent it deserves—and one of these is the "sweet herbs."

In therefore advising an alteration in this department, I do not, by any means, advocate any serious change all at once; in fact, the condition that many things may be in prevents that radical change taking place immediately with advantage. It would, therefore, be better practice, on the part of the young gardener, to look over his grounds, and see if another place, equally suitable, be at liberty, when a portion of each kind can be transferred, preparatory to the whole plantation being there; and as many things remove at this season better than at many others, such may at once be taken away, or rather young plants, slips, or offsets of them, leaving the old beds to keep up the supply until the young ones come into use. Now, as most of herbs propagate very freely, if attended to at the proper time, little need be said beyond, that in such things as *Thyme*, there are usually plenty of seedling-plants arise from seed "self-sown," all around the bed or border where the old ones are, these, removed with care, speedily make fine plants. *Hyssop* and *winter Savory* often propagate themselves in the same way; while *Mint*, spreading laterally as far as is allowed, often dies in the centre, or otherwise becomes so exhausted there as to produce very little that is worth preserving. The best time to transplant *Mint* is when the young shoots are some two or three inches long, when they may be taken up with a few inches of the runner stem attached, and planted where wanted. A damp, deep soil suits *Mint*, but more especially, the *Pepper-mint*. Rooted offsets of *Fennel*, *Sorrel*, *Burnet*, *Angelica*, *Chamomile*, *Tansy*, *Tarragon*, and some others, are easily obtained in a general way, and may be at once planted in such proportions as is expected to meet the demand, and a little (but very little) over to meet contingencies. Those of a more woody or shrubby character are best propagated by cuttings; of this class are *Lavender*, *Sage*, *Rue*, *Wormwood*, and some others. Cuttings of these, however, do best if put in some time about Midsummer,

in dull showery weather, when they will root so speedily as seldom to require shading. On the other hand, some plants are propagated most easily from seed; these are, however, of a sort of annual growth, as *Marigold*, *Chervil*, *Basil*, and *Marjorum*; but some others are also easily raised from seeds, which, however, ought to be sown on some well-prepared bed, and not too early in the season to endanger its vitality from causes over which we have no control—as the dampness of the season, and other ungenial causes. It is also imperative on all who grow herbs for the use of a family, whose wants they are but imperfectly acquainted with, to grow a good breadth of the last-named three kinds, as they are more generally used than many others.

Now, in making these remarks on Herbs, I have not, by any means, mentioned the names of many plants required to make out an extended list; but enough has been said to assist the amateur in the cultivation of each section requiring a different course of action, and some of them as, for instance, *Pennyroyal*, requires renewing every year; the spreading character of the plant soon forms an acquaintance with its next neighbour, and, towards autumn, often leaves the centre of the place deserted by everything alive, unless it be, as I have said in a former part of this chapter, that “weeds” had usurped the original position of the *Pennyroyal*. *Chamomile* may, in many instances, remain two years in the same place, but longer than that cannot well flourish without more assistance than can be granted them. A fresh plantation may, therefore, be put in as opportunity offers; and all vestiges of the former may be removed if the plants put in are at all vigorous and healthy.

Of the kinds which do not present us with rooted offsets to any extent, *Sage* stands pre-eminent. It, and others like it, must, therefore, be propagated by cuttings, put in as soon as ever the young shoot attains a sufficiency of hardness to enable it to maintain itself on the moisture of the ground and atmosphere while its lower extremities are preparing roots. This is usually about Midsummer; and if advantage be taken of any showery weather that may occur then, there is little trouble in obtaining any requisite number of plants, which may either be struck in the bed where it is intended to be grown, or in some other place from whence it can be removed when rooted. This latter plan is the best when the weather is too bright and sunny to expect it to do well in its ordinary abode. All herbs of a half-shrubby character do equally well in such a place, as *Lavender*, *Winter Savory*, *Rue*, *Southernwood*, *Wormwood*, *Hyssop*, and some others; but, as the collection of sweet and pot herbs embraces many plants of different habits, we have entered into the above details of the culture of each in order to be fully understood in all; and for the guidance of those who wish to cultivate the largest and most varied collection of herbs, we advise them to examine the number and varieties of those who compete at many of our “local horticultural shows” for prizes there offered for this class of plants, and they will then find species which they believed to be obsolete, but which the competition to excel in numerical strength had called into existence again. To such a length has this, in some instances, been carried, that a collection of herbs might not unlikely be mistaken for one of “British plants,” so many species of the latter finding their way in there—no doubt, but on some authority on their respective merits; but as the sophistry of “Culpepper” is no longer regarded, we hope no one will overload a collection of herbs with plants recommended by him as possessing all the merits of a universal medicine; and though we do not, by any means, despise the medicinal properties of many of our wild plants, yet we think some limits ought to be put as to their being received into the family of herbs, with no better claim than that somebody's grandmother had reported such a

plant “a safe and certain cure” for such and such a disorder. J. ROBSON.

THE COTTAGE GARDENER'S PONY,

WITH THOUGHTS ON A CARRIAGE.

SOME idea of distinguished rank has ever been associated with the circumstance of a man's being carried about by a more elaborate contrivance than the use of that ‘pair of shanks'-galloways’ wherewith Nature has set every one of us up, duty free. Much difficulty would be removed from my subject by coming to a clear understanding on this point; and, accordingly, I propose to say a few words on the symbolic meaning which, in all times, has been attached to matters of equipage.

Thus, “he had twelve sons who all rode upon white asses” means, twelve young men of exalted station and acknowledged rank. “Oh ye who ride on white asses!” the same. When the Hebrew captive was set upon the king's horse, and paraded in state through the city, a great deal more was implied than the mere enjoyment of a ride out. These expressions are highly metaphorical, and carry a meaning with them, which is borne out by the common figures of speech of all nations. The Roman emperor riding on a horse shod with golden shoes, which he was made to scatter about amongst the crowd, presents us at once with a tolerable idea of magnificence. Bolingbroke's triumphant entry on horseback, when he first vindicated to himself the title of Henry IV, is described by our Shakspeare in a way which shows his knowledge of this trait of poor human nature; and a ridiculous example is given of the same thing in the story of that self-important Irish baronet, Sir H. Trumington, who was never seen in town on foot, but who regularly mounted his horse at his own door, No. 23, to get off again to call at No. 25 A, where his mother resided.

In the account of a successful *coup-d'etat* which came off some two or three thousand years ago, we read, “they put to death all those who were carried about.” This does not mean that the conspirators cruelly cut off the aged and infirm, but, on the contrary, all the greatest men of the state. Similarly, the chairing of members; the Queen's procession to and from parliament; the Lord Mayor's coach; the Judge's carriage wherein he is conveyed to court and back again at Assize time, all signify much the same thing. When Buonaparte, on his return from Elba, galloped in his carriage right down upon the front of the arrayed royalist army, the poet observed, “Fate sat in that carriage.” True enough, fate often seems to sit in a carriage. Only think of that unparalleled state coach in which Napoleon went to be crowned. How many escutcheons have since been emblazoned on those same panels! And the other day Louis Napoleon drove down in it to be married; to be married! an occasion when, if ever in this life the most rigid utilitarian symbolically expresses his (or her) elation, by dashing to church in grand array.

Very proper it was of My Lord Judge, the other day, to reprimand the north-country Sheriff (member of the Society of Friends), who had not provided the usual costly vehicle for the Judge's use. As the representative of royalty, My Lord undoubtedly required to be conveyed in right royal state.

I have not quite made up my mind whether or no the Judge's carriage is itself degenerated from a certain venerable old waggon which, amongst our northern progenitors, was solemnly drawn up and down the country by a team of oxen, upon a kind of circuit or tourne, exciting more awful feelings of respect from all than the most juvenile members of society now pay to any of the pageants which are still most properly continued, in these days, to impress upon the very young timely notions of what is due to rank and station. How many young apprentices, fresh from the country, are moved to emulate Richard of Whittington, by the first impression produced on their minds by the Lord Mayor's Show!

The wandering Scythians, cousins-german to our Anglo-Saxon ancestors, certainly introduced family carriages into Europe. Whenever the enemy invaded the country, they were accustomed to order round to the front door a very

primitive conveyance—an omnibus of the roomiest imaginable dimensions, drawn by oxen. Into this all-capacious receptacle they packed their families, their goods, their house itself,—all and everything was put upon its wheels. And thus, say the historians, they preserved their liberties. They had no towns, no fortresses to leave behind; and by retreating into the interior, they either eluded the enemy, or else led him into some desperate scrape, and then fell upon him when they had him in a fix.

Wonderful is the hereditary force of habit. Look at an unwieldy four-wheeled affair of the present day; every possible advantage taken of its capacity by stowing into it "my sister and my sister's child, myself and children three," and, may be, a nursemaid or two, articles of millinery, bonnets, the groceries, the butcher's basket, and what-not besides (the driver was almost forgotten, a man of fourteen stone). Call this one-horse carriage of eleven hundredweight what you will—a Clarence, a double Brougham, a fancy fly, a demi-fortune, a britscka,—it is in reality a Scythian waggon, and should be drawn by a team of oxen. It is for something more than for relaxation, or the excitement of the thing, that an Englishman drives this mystic van. There is some remote traditional impression in his mind; some mysterious, long-forgotten association of ideas required to account for this characteristic national trait. I have said something about names; but surely the name of Phaeton, the fastest of all fast young men, should never be associated with such an equipage as we have been contemplating.

A country gentleman's coach of the last century was a ponderous machine of about a ton-and-a-half in weight; and being suspended on leathern braces, the weight was made to tell as unfavourably as possible upon the horses' shoulders at every jolt of the road. But nothing less than a certain conventional weight of iron and timber would do to set forth in due form the rank of the occupant, and for this purpose the thing worked very well; as a locomotive, perhaps, it might have been improved, but that was a secondary consideration. Four horses were required for travelling, and for state occasions. Afterwards, bad times compelled a retrenchment of the leaders. The next generation saw our great people painfully dragged about by two horses set to do the work of four. In our day this, at last, has been righted, and our pair-horse equipages are generally well-arranged, not too heavy, fully as convenient as before, though made at one-third the cost, and of half the weight. But the dignity of our one-horse carriages is something positively oppressive; half-a-century behind all received theories of modern progress. They are just where the old chariot was when first reduced to its single pair of horses. The coach-builder must yield to the times; our great middle class must not be suffered to cherish the exploded theory that the weight of a man's character has any relation to the weight of his one-horse chaise. You may be worth half a plum, and I wish you joy of it; but half-a-ton of wood, iron, and leather, is too much dead weight behind any one horse. Brother Jonathan sent over pretty clearly his ideas upon "the English horse-slavery question," when he packed off a few of his trotting waggons for our great Exhibition. There was an Irish car or two, I believe, also to be seen, which might have been studied with advantage. One of the American little phaetons was afterwards exhibited about the Houses of Parliament, and seemed to run remarkably light: it was drawn by a pony. The real Irish horses are mostly undersized; even the Russian drosky is often run by a pony. Think now, for one moment, of the Emperor of all the Russias wrapped in his cloak, seated on the scanty bench of his drosky, his feet let down in a sort of well between the fore and hind wheels, with a driver perched upon the dash iron before him, the whole concern drawn from one post to another by a little scampering Cossack nag!

Sir Gardiner Wilkinson has given us his ideas of the extreme lightness of the Egyptian chariot. It might be carried across the country when the roads became impassable. It was a mere shell of a thing, like an Irish car without the let-down sides; the gentleman mostly stood to drive, and the floor was elastic. Juno's car, in Homer, was much the same, with a seat across, suspended by thongs, after the fashion, it may be, of our farmer's shandraydans.

Last, not least, of the light cavalry. Our British ancestors were famed for their handy little cars; and a London-built

carriage excited as much admiration in Rome in Cicero's time as it does now. I have before me a paper on ancient British chariots, upon which I could found my case for a complete reconstruction of modern ones.

Our "pony" is quite as large as the original car-horse; and horses, we all agree now, were put in harness centuries before men mounted upon their backs. But the first saddle-horses were not very tall; it took about a thousand years to invent stirrups, and you cannot mount the high horse without them.

Our "pony," then, should be about fourteen hands and a half high (Bucephalus himself was no bigger), and the carriage now hardly be above a quarter-of-a-ton in weight, and if on two wheels, and without a head, it may be made considerably lighter. If on one pair of wheels, these should be 4 feet high; if on four wheels, the front pair 2 ft. 6 in., the hinder ones 3 ft. 6 in., or thereabouts.

The farmer invariably roots up the last crop, and clears his ground well before he begins to sow his seed; so I wish to disencumber my subject from many superstitious essays which, I believe, date from the time when oxen were employed for draught—a practice now decidedly on the wane. Even our ploughs are now greatly lighter than formerly; so was the mail coach; so are our gentlemen's carriages; but pony phaetons, and one-horse flies, are still in want of reform. The cart too often is still very heavy. According to the very idea which was once predominant among his betters, the country farmer, if well to do in the world, sets up a huge state cart, which requires one horse to set it in motion, and he then yokes another horse in front to draw the load. In some parts of the kingdom they still retain the old two-horse or four-horse waggon. Yet a light small cart, with a little horse in it, will get through a vast deal more work in proportion. Ceremonial observances have a great deal to do with even carts and cart horses.—VIBGYOR.

POULTRY MATTERS.

ENGAGEMENTS, of one sort or another, have prevented me troubling you for some time past; allow me, if you please, to bring up my arrears.

Of the relative estimation in which the different breeds of fowls are held, little remains for me to say, after the results which you have published of the different sales. In the opinion of the public every one must admit that the Cochins "have it," and I still think deservedly. I am not, however, one of those who believe that the enormous prices lately given are at all likely to be maintained. A good kind will always fetch a good price; but those prices to which I have alluded are quite ridiculous.

With the question of *nomenclature*, I am not about to trouble you further than to express my concurrence with those of your correspondents who contend that it ought to be uniform. You, for instance, think "Shanghae" proper; I still incline to the old name of Cochin. My principal reason is that I have been told by those who brought them over that they are called, at Shanghai, "Cochin-China fowls;" and that the original stock came from that country. You have reasons, no doubt, the other way; but it is desirable, I think, that all should understand the same name to mean the same thing; and should, therefore, call the same thing by one name.

I have to express my acknowledgments, and those of several brother amateurs, to your correspondent "W. C. G.," for his information respecting the "*Brahma Pootra*" fowl, from which, and the result of other inquiries, I am led to believe that this will prove to us a valuable variety. Any other facts relating to it will be interesting, I doubt not, to many of your readers.

This induces me to notice the subject of *cross-breeds*, referred to by another correspondent (A. S. W.). Though fairly resorted to for the purposes of experiment as of the table, such trials should be made with caution and judgment; and I would express a hope that those who prepare prize-lists for Poultry Shows, will, for the future, omit such a class as "cross-breeds," or "any other breed;" and say instead, "for any other distinct variety," so as to let in the *Brahma Pootra*, for instance; or the *Demerara* fowl, in

praise of which I have heard something said of late, and of which I should be glad to hear more.

While on the subject of varieties, allow me to add my protest against what are called "*Rose-combed Dorkings*." I believe that these are all mongrels, and as such I deprecate their introduction into the prize-list.

As the first, I believe, of your correspondents who pointed out the numerous objections to *dealers being appointed to the office of judge* at our poultry shows, allow me to thank you for your observations upon this, to all exhibitors, most important subject. It is perfectly true, as you say, that "if the office is to be filled by competent persons, public confidence must be accorded to them;" but, let me add, that the converse of the proposition holds good, and that if public confidence is asked for, not only must the office be filled by persons who are competent to perform its duties, but by those of whose fairness and impartiality no one can reasonably entertain suspicion. Gentlemen of character and station; men, indeed, of every grade, from the peer to the peasant, are turning their attention to this interesting subject; many of them are sparing no expense in their endeavours to improve the different varieties of our domestic poultry. They buy, more or less, from dealers, and they look to the exhibition, local or otherwise, as it may be, for the means of comparing their specimens with those of their brother amateurs, and of securing the unprejudiced opinion of disinterested judges. Is it not natural that they should feel disappointed, to use no harsher term, when they find that the judge is the very dealer of whom their competitor bought his birds, and declared, of course, by the said dealer, to be "the best in the world;" or the stock from which he bred them. This has been my case, and it may be the fate of any exhibitor, wherever such a practice is allowed to prevail. Dealers are not permitted to exhibit; the reasons against their being allowed to act as judges are infinitely stronger, and are well stated by your correspondent, "N.," in a recent number. I have heard it contended, that every one who sells a bird is a dealer. But every one knows that a "dealer" is one who buys to sell again; although I readily admit, that the objection applies, in a lesser degree, to those who have bred for sale. And I know several, among whom is Mr. Sturgeon, who have declined to fill the office of judge on this very ground, that they would not subject themselves, and the office of judge, even to a suspicion.

Allow me to congratulate you, who have done so much, as all will acknowledge, to promote and extend the efforts of amateurs in this direction, on the increased and increasing number of our exhibitions of poultry. As a fancier, of many years' standing, and who can speak of such matters before they became "fashionable," I look upon this as a far more convincing proof of the rapid extension of our favourite pursuit than the great prices which good specimens have lately realised. I, however, entirely concur in your observation, that the sub-division of districts should not be too minute. For this reason, I hail the establishment, which I had the pleasure to announce to you a few days ago, of an exhibition of Fat-Stock and Poultry by the Great Yorkshire Agricultural Society, to be held at Leeds, in December, as a step in all respects in the right direction. I trust the managers of this show will steer clear of all objectionable arrangements in the outset; a course, allow me to add, much easier to be adopted than that of giving up a practice once adopted, by which, however prejudicial, some must necessarily have benefited. The matter, however, appears to me to have been taken up by the Society in question in good earnest, and altogether in a proper spirit. I observe that they have provided against the unfair practice of allowing old and young birds to compete in the same classes; and that they have omitted several restrictions, of which the benefit was at least questionable, while the mischief of them was proved by their constant evasion. To this, as to many other subjects, the sage advice of Lord Denman is applicable—"Rules of this sort are not required for good men, while bad ones are almost certain to discover the means of evading them." The selling clause is also absent from the published prize-list. If, as you state, upon the authority of the *Midland Counties Herald*, to have been the case at Birmingham, an exhibitor is to be allowed to "buy in" his birds, in clear violation of

the rule that a sale must take place if the price named be offered, I would at once include that rule in the category just referred to, of those involving more of mischief than of good. But my notion is, that all purposes would be answered by allowing those who might think fit to mark their pens "Not for sale," and those who might desire to dispose of their specimens, to name a price at which, if offered, they should be bound to sell. There is a new rule at Birmingham which, with all submission, appears to me extremely absurd, that, namely, which restricts a subscriber to half-a-dozen pens. If it had required an additional subscription for all above a certain number, to meet expenses, not a word would have been said; but, as it is, it is restrictive of the very object of the exhibition, with the additional objection of having been glaringly evaded. I am happy to see, from the Leeds programme, that the birds are to be received up to Monday night, and judged on Tuesday morning. A few extra hands will easily arrange the pens in time for the judges to commence by daylight. A division of their labour will shorten the time required by these latter for the performance of their duties, with the additional advantage of submitting *each* class to the judge best acquainted with its peculiar merits; and I am fully confident, with your correspondent, "N.," "that plenty of competent men in each class could easily be found, if dealers were excluded;" for, with them, depend upon it, few gentlemen will act. There is, however, one point which I will take the liberty of suggesting, before it is too late, to the managers of the proposed Yorkshire show, and to others similarly situated. It is to close by two or three o'clock on the Friday, so as to ensure the arrival at home of all the stock on the Saturday, by sending off such as have a long distance to travel by Friday night's train. I agree with those of your correspondents who think three days sufficient during which to shut up valuable birds in their pens; but, with good care, I do not think one additional day of very great importance; and, considering the expense necessarily incurred by a society in such an exhibition, properly conducted, *within doors*, when the days are short, I submit to both parties that it would be a fair compromise to receive them on the Monday and send them off on the Friday night. At all events, a step has been made in the right direction, and if the Society will, as they still may, concede the few hours on the Friday evening, I hope exhibitors will be satisfied at least to let the experiment be fairly tried, for, in that case it will, beyond doubt, be a great point gained.—COCHIN.

P. S.—Just as I was dispatching the above to you, I received a circular enclosing a paper, to which I have, without hesitation, added my name, pledging those who sign not to exhibit where dealers are judges. It is intended for publication, and, I understand, has already been signed by thirty to forty amateurs. Many more names will, I doubt not, be attached, and I trust it may have the effect of putting an end to a practice indefensible in principle, and objectionable to so many exhibitors.

ON SEEDLING PELARGONIUM GROWING.

He must needs be a bold man who ventures to find fault with, or even to question any of the communications of your talented contributor, Mr. Appleby. Yet, as it is by rubbing our ideas and experiences well together that our practical knowledge is improved, I will venture, even at the risk of being thought presumptuous, to offer a suggestion on raising seedling Geraniums, somewhat opposed to the directions given in the article on that subject in your number of the 17th inst.

In the article alluded to it is said, that the seed, when saved, should be laid by, and sowed the following February, in a house or frame heated to 55° or 60°, and then, by keeping the plants growing, several may flower that season, and the rest the following year. This may be very well for those who are fortunate enough to possess all "appliances and means to boot," though even by such, I suspect some time, and much valuable space, may be saved, by sowing, as I do, directly the seed is ripe; but to the small fry of amateurs, who, like myself, only possess a modicum of a greenhouse (in which they endeavour to grow "*omnibus*

rebus et quibusdam aliis"), and, perhaps, two or three cucumber and melon-lights, the course prescribed amounts to a positive prohibition, so far as Geranium seedling growing is concerned, of a pursuit, so dear, for reasons well stated by Mr. Appleby, to all ardent florists.

My plan, however, enables me, with only the limited convenience spoken of, to grow between one and two hundred seedlings each year; and though I have not yet astonished the world with my success, so far as the production of novelty goes, I have found all the pleasures our friend so well describes, even in my disappointments. It is said, that Bruce, taught by the indomitable perseverance of a spider, was encouraged, after losing eleven, to fight and win his twelfth battle, and the crown he fought for. My defeats have been about as numerous; perhaps in this, my twelfth attempt, victory awaits me. But to my plan.

As soon as the seed is all ripe, which with me is seldom before the beginning of August, I sow, and place the seed-pans in my latest-made, and, consequently, warmest cucumber-bed. By the time the plants show their second pair of rough leaves, I pot into small 60's. This will be about the middle of September, and by that time there is a light or two of cucumbers ready for sacrifice, and there, having raised the soil to about a foot from the glass, and put two or three inches of coal-ashes on the top, I place the plants, and keep them growing as fast as possible by frequent syringings, and shuttings-up of an afternoon, but with plenty of air at all other times, till about the middle of October, when the pots will be well filled with roots. During this time, indeed, if the weather is, as it frequently is, very warm and dry, I syringe and shut-up for two or three hours every afternoon.

Where the pots are well filled with roots I repot into large 60's—just a shift. The soil for this last shift is simple loam two parts, and sand one part; but I pot them from the seed-pans into soil, such, pretty much, as we would bloom Geraniums in. After the plants have got well hold in their second pots, the object, of course, is to harden and get them well to rest for the winter.

In December, according to the weather (this year it was not till the latter end of last month, when I wanted to be preparing my pits for spring work), I get the plants into my little greenhouse, putting them in any odd corner or shelf wherever they can be crammed. It is here, by this un-gardener-like treatment, they get a little drawn, but I find this is not of importance to seedling Geraniums. About the latter end of February, or beginning of March, when severe frosts seem to be apprehended, and when I begin to want to spread out the legitimate tenants of my greenhouse, I repot with good Geranium soil, not forgetting plenty of charcoal, into 48's or 32's, according to the size of the plants, and then pop them about at every window of my dwelling-house, in cold-pits, or anywhere where they can have plenty of air in the day, and the protection of glass at night, till the beginning of June, when all that are not showing bloom are placed in the open air, in a situation sheltered from the north and east, and as these, one after another, throw up their bloom-truss, I bring them into the greenhouse that they may have a fair chance of developing the beauties that are to "astonish the Browns."

By these means I bloom *all* my plants the first season; and any of my brother amateurs who may adopt my plan, will find that a very considerable number of seedlings may thus be grown in a comparatively small space, and that without encroaching on what to most of us is so much in request in the spring—space in our dung-heated pits.—J. S.

LACED *versus* SPANGLED POLANDS.

As the remarks of "Scrutator," in a recent number of THE COTTAGE GARDENER, are calculated to mislead the uninitiated (and, indeed, have misled a young friend of my own here, and set him all agog after Poland that are laced), I think it right to correct them.

"Scrutator" takes his cue from the Rev. Mr. Dixon's work; but does this learned author injustice, by misquoting him; for Mr. Dixon nowhere says, that the Gold or Silver "are not, or ought not to be, Spangled." On the contrary, speaking of the *Cork* Golden Poland, he writes, "the breast

and wings are richly spotted with ochre and dark brown;" spotted being but another term for spangled. In alluding to the Poland hen he certainly does indiscreetly use the word laced.

Though "Scrutator" kept Polands, now twenty years ago, so far from this giving authority to his opinions, I judge it rather detracts from them; for these are days of poultry progress, of selection, of improvement, and of exhibition: what would do very well in those good, old, isolated days, might prove very inferior in these times of competition, and comparison with others.

The Birmingham Judges are condemned by him, because they would not confess to the super-excellence of Laced Polands. Although he goes too far, I do heartily concur with him in the sentiment, that very few Judges, indeed, are acquainted with the points of all the varieties of poultry they decide upon; it is a sore evil, and one which demands and *must* receive alteration.

De facto, and in truth, the Gold and Silver Polands are spangled fowls; as much so as are the Spangled Hamburgs (properly called), and as such, they ever have been, and ever should be recognized. It is probable that, by careful and persevering selection in breeding, a laced variety may be established, or induced; I would protest, however, against the capricious change and metamorphosis of a natural and distinct variety of fowl to an artificial state; and the more so, when, in frittering away its characteristics, you in the same degree lessen its beauty. The slightest observation must convince any one that a spangled fowl not only presents more distinctness, and more clearness of contrast, but that it is, also, more effective in the richness and brilliancy of its colours. Nor is this mere opinion; it is so, and of necessity: a moment's consideration will prove it to us. Let us look at a spangled feather; whether it be Silver or Golden, the ground colour is clear and unclouded; the spangle is a mark of considerable size, well and distinctly defined on the edges—it is a concentrated mass or body of colour—placed, or extending, let us not forget, upon the more substantial part of the feather, where the texture is firmer and closer. "Of necessity," then, the spangle, being a large and concentrated body, it becomes lustrous and brilliant, from its presenting a greater surface for the reflection of radiant colour. In the laced feather all is contrary: the distinctive character is lessened, the ground colour appearing less apart, as it is surrounded by the marking; that marking, or lacing, is but a narrow strip or line, placed on the edge of the feather, where the texture is attenuated, thin, and often the reverse of smooth. Need I draw the comparison and conclusion? Can a mere line, with little depth or body of colour, placed on such a texture and surface, and alike in all parts, *can* this produce the distinctness, the brilliancy, and the contrast of a spangled feather?

That it really does not, we have abundant proof. Let us take, as a perfect example of a laced fowl, the Golden Sebright Bantam. There is no brilliancy of colour here, yet the lacing is correct—trim and exact as may be; whilst another Bantam that is degenerating, as it is called—that is, becoming spangled—is confessedly both rich and brilliant in its marking, though incorrect in manner. But there is nothing like practical ocular proof; I, therefore, enclose a breast feather from a very dark-coloured cock Golden Spangled Poland. It is spangled, but laced also. Can anything be more different in effect than the brilliancy of the spangled, and the comparative dullness of the laced portion?*

Laced Polands, especially in the Silver class, occasionally appear; in every hatch of chickens some are less perfect than others, being too light, or too dark. When too dark, or "full of colour," as it is termed, this state will be found to depend on the lacing of the feathers, as evinced in two pullets now in my possession, and which were shown at the Baker-street exhibition. They were passed over, while some spangled birds were awarded a prize, and sold for six guineas.

I am curious to know, in a spirit of good-humoured pleasantry,—I pray tell me, Mr. Editor—if the laced feathers sent you by "Scrutator" were large, or portions of large, feathers? Because the young friend of mine here,

* The contrast is very striking.—ED. C. G.

before alluded to, has just had one sent to him, and I fancy the same as yours, that really, really, was not a fair example. It was actually the piece of a large feather, extracted from the wing coverlets! Now, such feathers are always laced in the purest specimens of *spangled* Polands! even in the spangled Hamburg, if my recollection does not fail me, such are laced too.

If yours are similar feathers, then, depend upon it, "Scrutator" is a wag, and but joking with the good-natured credulity of your readers. Do ask him for feathers from the breast, not from the sides of the breast, but *crop feathers*; these are the touchstone of lacing; so bait your trap, and, my word for it, he will be caught, if he be "poking fun" at us all.

Finally, I enclose you a larger-sized feather (but less than my friend had sent him), from the wing covert of, perhaps, as fine and true a *Spangled* Poland as can well be; of course the *lacing* of the feather is perfect, for all purely-spangled fowls have the larger feathers of the wing coverts laced!—F. R. HORNER.

[The feathers sent to us by "Scrutator," whose direction we very much wish for, as we have some questions he could probably answer, were good and entire specimens. We shall publish, next week, an engraving of a laced feather which came from him.—ED. C. G.]

P. S. Mr. Bailey, in his recent work on Poultry, and all other authors, describe the Golden Poland as a *spangled* fowl. By-the-by, Mr. Brent's notion of a spangle is truly unique, and, let me assure him, it is quite apocryphal. The colour of the spangle may be any one of the prismatic colours—red, orange, yellow, green, blue, indigo, or violet, or, it may be, black, or white, on a contrasted ground colour.—F. R. H.

[It is only within a very recent period that the characteristic markings of fowls have been generally recognised and sanctioned by the awards of judges.

That twenty years ago there existed a breed of laced Polands, with *every* feather in strict compliance with the requirements of that marking, we are not at present prepared either to prove or deny. All we say is simply this,—that such birds we have not ourselves seen.

"Scrutator's" specimen of the silver-laced feather was unquestionably good, whether it was a wing covert, or from the breast or back. As a mere feather individually, and *per se* did we then speak of it, expressing our wish to know where birds thus marked throughout might be attainable.

We then alluded to such laced birds being distinct from those termed *spangled*; and Dr. Horner, we imagine, is correct in saying that the greater wing coverts, in both gold and silver Polands, are usually laced, at least, that the spangle is so prolonged in a narrow line on the outer margin of the feather on each side, as to warrant the application of this term to those particular feathers.

But the shape of this spangle varies. To our own eye, that which presents a convex side to the base of the feather would have the preference over what, from its concave form, might be called the horse-shoe spangle; the outline is better defined, and the colour better massed. The whole question, however, of "*spangle versus lacing*" stands thus:—

The class "*Gold and Silver Polands*" is commonly understood to denote Spangled birds; so that when a truly laced fowl of this family, *i. e.* not with lacing in any one part of its body only, but with lacing *throughout* as the main characteristic of its plumage, shall make its appearance, competent authorities must then determine whether it shall compete on equal terms with its Spangled relative, or require the formation of a separate class. But such a fowl, we repeat, we have never yet seen, for the Spangle, more or less, has ever been apparent; hence, therefore, our desire for such as we pictured to ourselves when "Scrutator's" specimen was laid before us, and his description perused. The Spangle, from the contrast of greater masses of colour, may be, perhaps, considered as the most effective marking; but we cannot lightly pass over the claims of the well-defined laced feather, where the ground colour, encircled by its clear dark margin, appears in such strong relief.

The lacing is necessarily seen to great disadvantage on the same feather with the spangle; the latter occupying the best portion of the feather, both as regards texture and

display. Separate feathers should, therefore, be taken for comparison. But we must wait for a Gold or Silver Poland with *unbroken lacing* before we venture to discuss the question at greater length. But, in the meanwhile, let not our thanks be forgotten, both to "Scrutator," for the communication of his views of Polish excellence, and to Dr. Horner, whose experience with his breed will ensure the careful consideration of his letter by every reader of THE COTTAGE GARDENER.—W.]

BEE-BOXES.

"EXONIENSIS" agrees in nearly all the observations I have formerly made in your paper in 1852. It is quite true that boxes, in a general way, do not answer so well as straw hives; they are more apt to get over-heated in summer, and more liable to be infested with spiders, which are insidious enemies to the bees, by entrapping them in detail, and, as your correspondent says, are too expensive for poor cottagers. What I wish to see is, "some new-fashioned cheap box-hive invented by some apiarian, which a carpenter can afford to sell at a price nearly the same as the straw hive; timber was never cheaper, for the last fifty years, than at the present moment; and surely well-seasoned wood might be had, and a good plain box invented one-and-a-half inch thick, at one quarter the price of those advertised, which I have stated to be entirely out of the reach of cottagers. I envy "Exoniensis" when I read his account of his bee country; Devonshire is, generally speaking, a good bee country. In 1849, I was at Ilfracombe, North Devon, and I purchased some of the finest honey I ever tasted. The combs were very heavy, and, as in Gloucestershire, it was but a poor season for honey, it plainly shows how favourable the bee pasture must be, as it was rather a dripping season in that locality. At the Chepstow Flower Show, in 1848 (a very poor season with us in Gloucestershire), I saw a box of bees exhibited with at least 50 lbs. weight of pure honey, probably from a good country not half stocked.

It is very well for bee-fanciers to praise the different curious boxes, which look very pretty, and answer very well in a general way, but who ever expects to see them general amongst the cottages of the labourers?

"Exoniensis" does not state whether any of his hives are in bee-houses, or whether they all stand separate. He says his boxes are fourteen inches square and seven inches deep; I like those made twelve inches square and nine inches deep. I approve very much of his glasses, as this is the best way of getting pure honey without destroying the bees, and is what I have recommended in preference to the uncertain mode of deprivation of the main body of the combs, which irritates the bees much more, and leaves a cause for many casualties.

From the immense quantity of rain fallen within the last four months, I fear the earth may be so chilled as to cause a very late spring; this will be the destruction of many weak stocks of bees where feeding has been at all neglected.

I have lately had some of the *Melilotus leucantha*, for the first time, in my garden, and recommend it very strongly as an excellent bee-flower. This is one of the good bee-flowers I omitted to mention in my list in those enumerated in THE COTTAGE GARDENER in the summer of 1852.—H. W. NEWMAN, *New House, Stroud*.

POULTRY ON SHIPBOARD.

I SEE you are publishing a work on Poultry. I have often wished for information on the subject, with a view to stock for shipboard. It is lamentable to see what numbers die in the over-crowded coops, especially in tropical climates, in a week or two after the sailing of the vessel; and with respect to those that do not die naturally, the leanness of the bird makes it hardly worth cooking. Blindness, partial or complete, is a common occurrence; but that does not hinder fowls being brought to table. In an East India passenger-ship, I have seen a dozen birds thrown overboard daily, or every other day, for a considerable period. Guinea

fowls held out the longest, and kept their condition better than any other poultry, which was a set-off against their almost intolerable clamour. The poultry of the ship were cared for well, as far as giving water and grain twice-a-day, and now and then sand. The man or boy who had charge seemed to know nothing about diseases, nor was any separation ever made of the diseased from the healthy. The ship's steward, being aware that fifty per cent at least would never live to be produced on table, thought to remedy the matter by filling the coops so that the birds found hardly room to turn round; the strongest forced themselves to the front, particularly at feeding-time; the weak, hinder occupants could hardly see their food and water, much less taste of them. Death remedied the over-crowding; so in a short time there was room for all to walk about.

I will mention one more evil, which was, the punishment inflicted by the healthy birds on the sickly, which no doubt helped to clear the coop. The food of the birds was always dry rice in the husk, called "paddy," differing not much in appearance from barley. Can you give a chapter in your proposed book as to the best method of preserving fowls on shipboard? Might it not be worth while making experiments on shore with birds in coops, in order to discover what space should be allotted; what kind of food would keep them in the best condition; and what substance should be given to assist digestion, instead of sand, which is certainly ineffective? Ignorance of the deepest shade prevails with regard to correct treatment on shipboard, and the consequence is, waste of money in the first instance, and bad food, if not the descent to salt-junk, for the passengers in the latter part of the voyage. Excuse my troubling you. The matter, for all I know, may already have been provided for sufficiently in some work of which I never heard. I see you have methods of physicking fowls. A pamphlet on the subject of treatment of all sorts, if provided for all ships' stewards, would add very greatly to the comfort of the passengers, and save money to the ship-owners or commanders. With regard to ducks, they do better than fowls. Geese are hardly worth taking on board for long voyages, so juiceless do they get.—D. C., *Elmfield, Southampton.*

[A more useful subject of inquiry could hardly be suggested than that contained in the above letter. And we trust to be enabled to devote some portion of our space in the forthcoming "*Poultry Book*" to its careful consideration. We should be glad, in the meanwhile, to receive any information bearing on the management of "*Poultry at sea*," that our friends may be possessed of. The ophthalmia (which, probably, often terminates in roup) alluded to would be easily accounted for by the dirt in which the birds, from their crowded position, were forced to exist, without referring to the effect of the "paddy," or unhusked rice, which constantly produces the same effect. Even the best samples of rice in this country would be injurious to the health of fowls, from its disposition to swell in the stomach if given unboiled for any length of time. Rice, indeed, as a poultry-food, should always be either steeped or boiled, the latter by preference. We will merely add, at present, that roomy coops, with floors boarded in front, but with open bars behind; sheltered from the weather, but with fresh air in abundance; regular feeding, with change of diet; a liberal supply of water, and gravel to aid their digestion, which, under such circumstances, must be sorely taxed; are such essentials, that, unless they are duly attended to, the salt junk, however uninviting, would probably be more tempting on the dinner-table than those unhappy inhabitants of the East Indiaman's hen-coop.—W.]

GOLD FISH IN VASES.

A *New Subscriber*, in No. 228, enquires for a work on "the management of Gold Fish in Glass Vases." I know of none such, nor indeed is any needed; so simple is the treatment they require, that it may be rendered in these few words: Change the water as soon as it becomes turbid. They require no other food than what the water may contain.

I once kept four fish, each about four inches in length, in a glass vase which contained about two gallons; the water being changed once a week in summer, and every

fortnight, or thereabouts, in winter. They were thus kept in apparent health for four years, and might have lived much longer, had not the cat been tempted by their glittering scales, and, to my regret, succeeded in catching the whole.

I usually take the fish from the pond in my garden on the approach of winter, and put them in a vase in the greenhouse; this vase contains about three gallons. They are never fed the whole winter. The plants are watered from the vase, which is again filled from the pump. About three or four times during the season the vase is emptied and cleaned, when it is again filled with clear pump-water.—W. SAVAGE.

DISEASES OF POULTRY.

INFLAMMATION OF THE STOMACH.

A FORTNIGHT since my advice was asked respecting a valuable young Shanghai hen, which had suddenly ceased laying, refused her food, and manifested every sign of severe illness. On examination, I found her extremely weak, very thin, and most unwilling to move or stand. There was no purging, nor running at the nose, nor were the eyes affected, although they were usually kept closed. From so short and imperfect a view of the case, I was unable to decide on the exact nature of the disease. I could only say it was not roup, nor fever, nor was the head affected. I suspected inflammation of some internal organ, and prescribed one grain of calomel. The gentleman to whom she belonged thought some stimulant was necessary, and added a little cayenne pepper. The woman who had charge of her had constantly crammed her, and I found the crop quite full. I expressed a strong objection to this proceeding; but it appears that the fowl was fed by hand until its death. One week afterwards I was informed that the hen had improved for two or three days after taking the medicine, but had relapsed. I again urged its not being fed by hand. On calling the following week, the dead fowl (having been killed purposely some hours previously) was brought for my inspection. On removing the skin of the breast, I found the flesh wasted to an extreme degree; the crop, which was healthy, contained a large handful of whole Indian corn; the enlarged part of the gullet that is situated within the body, and which almost appears to form part of the gizzard, was in a violent state of inflammation, the inner lining being blotched with red, and the whole organ somewhat thickened. It is in this part (which is termed, by comparative anatomists, the proventriculus) that the food, after it has been softened in the crop, is subjected to the action of the digestive fluid (viz., the gastric juice), the gizzard being merely a grinding organ. The other organs of the body were in a healthy state. The ovary contained an immense number of very small ova, and the egg-passage, or oviduct, was small in size as in hens that are not laying. I could not trace the disease to any particular cause. The hen had recently, with others, been removed from the country to a large stable-yard in town, and well supplied with fresh vegetable food. I mention the case as a warning against the injurious, and, in this case, as it turned out, excessively cruel practice of cramming a sick bird. The suffering occasioned by forcing food into an inflamed stomach must have been intense. In the inflamed state of the part no digestive fluid could be found, and the food, consequently, was undigested, the intestines being empty, and the bird thin from want of nourishment. Had the calomel been given without the cayenne, the bird kept comfortably warm, and supplied with some thin fine oat-meal and water, or boiled rice, cooked potato or turnip there would have been a very good prospect of recovery. As it was, the fowl was literally killed with the mistake kindness of the woman who had it in charge.

W. B. TEGETMEIER, *Tottenham.*

EARLY LIFE OF THE POOR MAN'S WELWISHER.

(Continued from page 272.)

HAVING told you how I persevered in learning to read will now tell you how I learned to write. My first plac

service was at a farm house, where I was drawn apprentice, and where I remained two years. This was no place for learning anything but hard work. I have often thought what a shame it is that poor farm servants never have one minute's time to call their own. Well may they be such an ignorant class of people as they are in some parts, but I hope they will not be angry with me for saying this, because I do not mean to say that all farm labourers are ignorant, because I have been in company with farming men that could talk with as much sense as any other men, and sometimes rather more. What I mean to say is, that they had no need to thank their masters for what time they allowed them to learn in when they were servants; at least, I found it so at this first place of mine, and at every farm house that I have lived at.

This sort of work would not do for me; I must be learning something. I accordingly left and went to live at a place where there were only a few cows kept and one horse. Now at this place I knew when my work was done, and my mistress also (for I had never a master) knew very well where to find me if I was wanted for any little job. She used to say, "You will be sure to find him down in the stable writing," Yes, and as sure as a gun there I was writing away as if I had had some law-suit under hand. Did my mistress grumble at me being there? No, for I always took care that my work was done first; and if I had anything to do extra, some times she used to treat me with a new copy-book as a reward. I had no one to instruct me, but I had an old book that had writing copies in it, and I one day met with an old baker that set me a few copies, and showed me how to begin some of the letters, and that was all the teaching I ever had.

My next place was a farm-house again, where there was neither time to read nor write, but I was determined to win. So I purchased a pound of candles, and wrote in my bedroom at nights, when I should have been asleep. So you see, where there is a will, there is sure to be a way.

My next place was to be under game-keeper, where I remained three years. I had then saved a little money, wherewith I put myself apprentice to a butcher, and when my time was out my master wanted to engage me for journeyman. I told him that I was about taking a wife; but if we could agree for wages, I had no objection, so we agreed that I should serve him for eight shillings per week, and my board, with several little privileges besides, which I reckoned to myself to be worth three or four shillings per week more. I now thought myself one of the most happy men upon earth, and so got married without delay; but to my sad misfortune, before I had entered according to my new agreement, my master failed, and was sold up.

Now, this was a dreadful blow to me. I had just married a wife, and I had now no means of supporting her. The highest wages that I could get at my trade was five shillings per week and my board. I knew very well that this would not do, and then as to my setting up myself that was no use of my thinking about, for I had no money. I had paid £15 to learn my trade, and that was all the money that I was worth, and my relations began to say that we should soon be in the workhouse, for I had nothing now to depend upon but hard work, and it was not likely that I could tie myself to that after being a gentleman so long!

This rather cut me to the quick; but I was not the man to be cast down, though my money was gone, and my trade of no use. I was both able and willing to work, neither was I ashamed of going to see where it was to be done; and in a short time a gentleman took me into his employ, where I have remained to this day, though not in the same employment, for when I first went, it was to work on the farm, but it grieved me to think that I had paid £15 to learn a trade, and after all was nothing but a farm labourer.

Now, I hope all young men that read these few lines, and are about making choice of a trade, will think of me, and consider well whether they shall be able to set themselves up in the trade they are about making choice of. If I had done this, you see I should have saved £15 by it; but it is no use of talking about shed milk; all that I had to do now was to consider whether there was any trade that I could learn now, that I could set up in without money. This was rather a difficult task; and that was not the worst of it, for

it must be learnt without money, or not at all. But I was not the man to be daunted, and I soon hit upon one, and what do you think it was? Why a gardener, to be sure.

Though I could set up to be a gardener without money, the difficulty was to learn gardening without it. It was not likely that any gentleman's gardener was going to teach me for nothing, which I knew he must, if he did do it; and I had no relation that knew anything about gardening. However, hesitating was all of no use, I was determined to win if possible; so as there were horticultural shows in our neighbourhood, and prizes given for the neatest and best stocked labourer's garden, I thought to myself, if I could do something in this way, to get myself noticed, I may, perhaps, get to work in the garden. So I bought a gardening book, and went to work to see what could be done, and accordingly the first year I was so lucky as to get the first prize for the neatest and best stocked labourer's garden in three parishes, with several prizes for vegetables and flowers besides, and have ever since been one of the luckiest men in the three parishes for obtaining prizes. This soon had the desired effect, and I was taken into the garden to work where I have now been for five years; so in a short time I hope I shall be able to say that I am a gardener.

TO CORRESPONDENTS.

. We request that no one will write to the departmental writers of THE COTTAGE GARDENER. It gives them unjustifiable trouble and expense. All communications should be addressed "To the Editor of the Cottage Gardener, 2, Amen Corner, Paternoster Row, London."

BULB LEAVES (J. B. W.).—The three leaves, marked 1, 2, and 3, belong to one kind of bulb, the true *Belladonna*; they are from pot-plants, and are six weeks in advance of those growing in the border for years. The three bulbs might look different, according to their age, or the kind of soil they were growing in, but there is no doubt of the kind. The bulb with the broad recumbent leaves, ciliated edges, and prominent veins, does not belong to any known *Brunsvigia*. *B. marginata*, which is probably a *Nerine*, is not at all marked that way. There are only two bulbs from the Cape known to have the fringe like your plant, and they are *Hæmanthus*; but the way your bulb is said to flower, candelabra-like, cuts it off from all that family. Keep your bulb cool and well aired, and allow it abundance of water for the next two months; and when the leaves turn yellow next May, pray send us one of them, and let us know if any dark stripes or blotches appear on the bottom of it next April, when it is full grown. You had better plant the *Belladonna* out in front of a south wall next June, when they are at rest.

CACTUS (Ibid).—The name of your *Cactus* is *Ackermanii*, as near as we can make out from your description. The blight on the *Rose-leaves* is *mildew*, which is very prevalent this spring. As the sulphur has not checked it, the next and only remedy is to have the blighted parts cut off, which seems very hard, but there is no help for it. We shall inquire further into all your questions, and tell you the result next week.

GRITTY PEARS (Pyrum signinum).—Pears may prove gritty for several reasons, but the most common cause is, perhaps, a lean and over-dry soil. Next to this as a cause, we should be inclined to say a cold situation.

CLIMBING ROSES (A Cockney Amateur).—"Two or three good climbing evergreen Roses," and one to be "rose-colour if possible." Take *Rosa indica major* for the rose-coloured; *Felicite perpetuelle* as the best of the breed of evergreens; and for the third, ask for *Myrianthes*, or *Princess Maria*, or *Princess Louisa*, or *Rampant*; but the first three will suit your north aspect better. When you write again, come to the point at once; short letters and quick returns form the grand secret of getting useful information.

INFLUENCING THE SEX OF CHICKENS—WHITE COMB.—*J. H. Payne, Esq.*, says:—"In your paper of this week, in THE COTTAGE GARDENER, on "Influencing the sex of chickens," you ask for the result of breeding from parents in their first year. I did so last year, from a cock and four hens. I reared about sixty chickens, upwards of forty of which were cockerels. Mine are Cochinchina. I am sadly teased with *white combs* amongst them; in some cases it spreads down the neck and breast, stripping off the feathers entirely, and leaving a white scurfy appearance of the skin. I have used cocoa-nut oil and turmeric, but with little effect. I am now trying alternatives, sulphur and nitre, as recommended by Richardson; and with others, nitrate of mercury, with lard, externally. With me, young fowls (that is fowls in their first year) are only affected in this way. In this neighbourhood I find it is very general. I find, also, that it is communicated from one to the other very quickly. If you can suggest a remedy, it will confer a great favour on many lovers of poultry in this locality (Bury St. Edmunds)." [I am much obliged to Mr. Payne for forwarding his experience, as to the influence of the age of the parents on the sex of the chicken. I have already received several remarkable results, and if our readers will kindly forward those facts that come under their notice, as suggested at page 412, I have no doubt but that a very interesting and useful table may be drawn up. With regard to the white comb, I can only direct his attention

to an article which seems to have escaped his notice, at page 272 of the present volume.—W. B. TEGTMEIER, *Tottenham.*]

HEATING A SMALL GREENHOUSE (*A Lover of my Garden*).—No mode can be better for you, we think, than that of which we give a drawing and description to-day.

CROWING HEN (*Chicken-hearted*).—Your hen which has not laid since you bought her, and which attempts to imitate the cockerels crowing, must be very old and barren. If so there is no remedy.

PROPAGATING BY LEAVES (*E. R., a new Subscriber*).—With due care you can carry on the process in your sitting-room, under a tumbler; bury half the section of the leaf in the sand. You may cut the leaf across as you suggest. Each piece can be made to grow. You will find very full particulars in *The Cottage Gardeners' Dictionary*, under the title "Cuttings."

BACK NUMBERS (*H. Kirkaldy*).—You can have all the numbers of *THE COTTAGE GARDENER* you mention, but you will have to pay *five-pence* each for them, if you require them to be sent by post.

HORTICULTURAL AND POMOLOGICAL (*Alpha*).—You are quite right when you "understand, that by becoming a member of the 'Horticultural and Pomological Association,' you can be supplied with all the seeds, florists' flowers, fruit trees, &c., that you require, the same as if you were to send an order to a nursery and seedsman; and that you can have the whole at a discount of 10 per cent lower than what you have been in the habit of paying." The Society offers great advantages to emigrants, in procuring for them, from various sources, the seeds, cuttings, and buds they require.

SHANGHAI CHICKENS (*S. P.*).—Yes; there are abundance of these "kept alive, though hatched since last Christmas." We see twenty of them daily. They are more than usually liable at this season to lose the use of their legs; but, if kept in a dry, cool place—heat excites them too much—with plenty of sand and lime rubbish to scratch among, and with such diet as egg boiled hard, Indian meal, scalded rice, scalded grits, and wheat crushed, they will do very well. Of course, as you warriors say, there will be more "casualties" than in more favourable seasons. Remember to give the chickens some *green* food to pick daily.

BEES—RUINED COMB (*T. Roberts*).—The only chance of saving the bees, in whose hive the combs have been broken down, is to leave them alone. They will take the honey from the cells, and then, when the spring arrives, you can clear away the ruins from the floor-board. Take care that the entrance is not blocked up.

STANDARD PLUMS (*C. J. N.*).—You do not say for what purpose you require them, we therefore give four of each as best for you. *Dessert*.—Green Gage, Purple Gage, Kirke's, and Royal Hative. *Preserving*.—Denyer's Victoria, Orleans, Goliath, and White Magnum Bonum.

RENDELL'S TANK (*A. P.*).—If "perfectly tight," the evaporation should be next to nothing; but if covered with slate, there will be considerable absorption and evaporation. Can any of our readers say what daily waste of water ought to occur in such a tank lined with lead, and 16 ft. long by 4½ ft. wide?

CAPONIZING (*T. M.*).—You will find very full particulars in the new and very recent edition of Richardson's *The Domestic Fowl*. The price of a cover for a volume of *THE COTTAGE GARDENER* is 1s. 3d.

BOTANICAL TERMS (*Quercus*).—We recommend you to buy that excellent little book *Henfrey's Rudiments of Botany*. The following extract from it explains the three words concerning which the books you quote disagree:—"The *insertion* of organs signifies the place from whence they apparently arise, and when *adherence* takes place this differs very much. When the organs, such as the stamens, arise distinctly from the receptacle, they are *Hypogynous*—below the germen. When the corolla and calyx adhere to the germen, the stamens appear to arise from the top of the germen, and which insertion is called *Epigynous*—upon the germen. If they adhere to the corolla or calyx while the latter are free from the germen, they are *Perigynous*—around the germen." In the Buttercup, the stamens are *hypogynous*; in the Strawberry, they are *perigynous*; and in Fennel, *epigynous*.

SHEEP BARKING TREES (*A Subscriber from the first*).—To prevent this, we think the safest and most enduring remedy would be to put a piece of small-meshed iron netting, three feet wide, loosely round each stem.

WEIGHT OF DORKING FOWLS.—Dr. Hitchman, of Mickleover, near Derby, says—"Owing to local circumstances, your interesting periodical does not reach me until nearly a week after its publication; and it is only now that I have read your statement to 'Charlotte Elizabeth,' that the cock bird of the Dorking breed ought not to weigh less than 10 lbs. This statement is calculated to mislead, and also to produce dissatisfaction and disappointment in a manner that you may not have contemplated. Supposing 'C. E.', acting under your advice, writes to a breeder of 'Dorkings,' and has sent to her a handsome bird of good weight—namely, 8 lbs.—will she not feel that she has been unfairly dealt with by the breeder, and be angry and miserable accordingly? As an amateur, and breeder of the Dorking fowl, I protest against this error. A Dorking cock weighing 9 lbs. is a first-rate bird; and I am sure that the average weight of male Dorkings, in the best show in England, will not exceed that weight, and it is with averages that you should deal in your editorial responses to such queries. Remember, Mr. Editor, that your 'Notices to Correspondents' are read greedily, and that your reply to 'C. E.' is information to thousands. I hope your 'Poultry Book,' which I look forward to with interest, will not propagate this error. You must have been thinking of your pet 'Shanghaes' when you gave out 10 lbs. to your fair correspondent as the *minimum* weight with which she should be

contented in the Dorking fowl. You write that the hen should weigh 7 lbs. I have no fault to find with this statement, but three pounds is an unusual difference in the weight of the two sexes of this breed. I infer you are not alluding to the *very choicest* specimens in your reply to 'C. E.,' because many hen birds at Birmingham weighed heavier than 7 lbs.; the *heaviest* weighed 8½ lbs., and I possess hen birds still heavier than this; but I have no hen of whatever weight that is three pounds less weight than a male bird of the same age. I think you will admit that there is no higher authority on the Dorking fowl than Mr. Bailey, of Grosvenor-street, and he states that 7½ lbs. is the *average* of the best strains." We readily bow to the authority of Mr. Bailey and Dr. Hitchman, and fully assent to their statement of the *average* weight of Dorkings. We intended no more than to point out to "Charlotte Elizabeth" the weights she should aim at. Dorking cocks of 10 lbs., and Dorking hens of 7 lbs., are to be had; and, therefore, with less weights we ought not to be content. We admit that they are rare, and Captain Hornby, writing on the point, says—"They will not once in a hundred good birds come up to those weights. I have only *one* cock and *one* hen weighing your weights."

CROSS BETWEEN THE PHEASANT AND FOWL.—J. C. says "I have observed a statement in your paper, that a cross between the pheasant and the fowl never was, nor ever will be. I must beg to say that I can assure you to the contrary, as I was eye-witness, twenty-nine years ago, to two birds being reared between a cock pheasant and a common hen, such as you may see in any farm-yard; and they were *very fine, healthy, and strong*. Any further particulars that may be considered worth inquiring on the subject, I shall be happy to give to the best of my knowledge."

EGG-EATING PULLET (*L. M.*).—Very seldom is the morbid appetite you complain of overcome. One similar instance, however, was successfully treated by a friend of ours. An egg was boiled hard; a portion of the shell removed, its contents mixed with a strong dose of mustard, and then replaced. The hen commenced her repast as usual, but the highly-seasoned dish did not please her, and the evil practice was subsequently abandoned. The cure, however, is rarely effected; and this case is probably a rare exception.—W.

HEIGHT OF THE UPRIGHT OAK (*P. B.*).—The upright Oak (*Quercus pedunculata fastigiata*) grows as fast as our common oak, under similar circumstances, and when grafted, as is generally done; but we had it true from seeds, gathered in the Pyrenees, and the plants rose considerably faster than any of the British Oaks for the first ten years. Some of these seedlings were quite as upright as the Turin or Lombardy Poplar, from this rigid form others of the same batch of seedlings departed, in various degrees, down to the "Knarled Oak." Hence it follows, that if grafts are taken from the best and most upright varieties, this singular oak will grow fast, and always keep to the upright habit. From twenty to thirty feet high is the general run in good deep dry soils.

FASTIGIATE ELM (*Ibid.*).—This is also a fast-growing tree, and grows quite upright, with curiously twisted leaves, and is altogether a very remarkable plant. What may be the habit of either this or the upright oak, when the trees are old, we cannot say. Perhaps some correspondent will answer that, and also mention the highest tree of each he knows. Thanks for the shortness of your letter.

VINE GNAWED BY A DOG (*M. S.*).—We are sorry to hear your promising Vine was so gnawed by an unpromising cur, that you had to resort to the healing art for bandaging; but, first of all, the bruised parts ought to have been carefully removed. The bandage is very good. If a shoot offers to come from below the wound next summer, it will be a sign that the dog went too far, and you must tie up this bottom shoot very carefully to form the future Vine.

ROSES NEAR LONDON (*Scrutator*).—The best Standard Roses to grow near London, are—*Madame Lafuy, William Jesse, Mrs. Elliot, and Baron Prevost*. They ought to be planted immediately, in pits twenty inches deep and thirty inches across; the first foot of the bottom to be filled with best rotten dung, one-half, and one-half *fresh* good loam, mixed; then plant with *fresh* soil or loam, without any dung, in immediate contact with the roots; then put a good layer of rotten dung on the top for mulching; prune close; stake well, and give a good watering once a-week from the middle of May till August; and, if you can get it, use weak liquid-manure each time; for without such stimulus you will not succeed so near London.

LAMENESS IN DORKINGS (*Horstead*).—The Dorkings are peculiarly liable to become lame, from their weight and the possession of an extra toe. Lameness is more apt to occur when their roosting perches are high than when not more than three or four feet from the ground. Since my perches have been lowered I have had much less lameness. When they fly down from a height they come with great force on the ground, and this constantly repeated concussion leads to a chronic inflammation, and thickening of the tendons and joints of the feet, which constitutes the disease frequently, but erroneously, termed gout. I doubt if any treatment is likely to prove successful in this complaint; the prevention is better than cure. Lameness frequently arises from corns, which I have found are readily removed with a sharp-pointed penknife, after the feet have been well soaked in the wet grass on a rainy day; they are much less readily extracted when the feet are dry.—W. B. TEGTMEIER, *Tottenham.*

LONDON: Printed by HARRY WOOLDRIDGE, Winchester High-street, in the Parish of Saint Mary Kalendar; and Published by WILLIAM SOMERVILLE ORR, at the Office, No. 2, Amen Corner, in the Parish of Christ Church, City of London.—March 10th, 1853.

WEEKLY CALENDAR.

M D	W D	MARCH 17—23, 1853.	WEATHER NEAR LONDON IN 1852.				Sun Rises.	Sun Sets.	Moon R. & S.	Moon's Age.	Clock bf. Sun.	Day of Year.
			Barometer.	Thermo.	Wind.	Rain in In.						
17	TH	St. Patrick.	30.333 — 30.299	48—31	N.E.	—	11 a. 6	6 a. 6	1 23	8 31	76	
18	F	PRINCESS LOUISA BORN, 1848.	30.262 — 30.182	44—31	N.E.	—	9	7	2 24	8 13	77	
19	S	Oak Beauty; oaks.	30.156 — 30.106	47—27	E.	—	7	9	3 20	7 55	78	
20	SUN	PALM SUNDAY.	30.142 — 30.103	50—25	S.E.	—	5	11	4 8	7 37	79	
21	M	Sun's declination, 0° 19' N.	30.191 — 30.107	63—27	S.E.	—	2	12	4 47	7 19	80	
22	TU	Brown-bordered; oaks.	30.120 — 30.108	66—28	S.E.	—	0	14	5 18	7 0	81	
23	W	Early Nettle-tap.	30.073 — 29.959	64—25	N.E.	—	v	16	5 43	0 42	82	

METEOROLOGY OF THE WEEK.—At Chiswick, from observations during the last twenty-six years, the average highest and lowest temperatures of these days are 51°, and 35° respectively. The greatest heat, 69°, occurred on the 19th in 1836; and the lowest cold, 16°, on the 20th in 1845. During the period 116 days were fine, and on 66 rain fell.

ONE-FLOWERED ABELIA.

(*Abelia uniflora*.)



THIS makes the fourth species of the genus *Abelia*, now in our gardens, all of which are either hardy, or nearly so. The present species, *uniflora*, is a low, evergreen, small bush, with white flowers, tinged with lilac, which are produced from between the leaves and the wood, on the extremities of the small side-shoots, and notwithstanding the name—one-flowered—the flowers come often in threes from the same parts. The flower-buds are cased in rich purple bracts, which have a gay effect, as contrasted with the large (comparatively) white flowers, and the deep green of the leaves. The leaves are not unlike those of *Fuchsia gracilis*, in size and shape, and the flowers may be compared, in these respects, to those of *Amphicomma arguta*, a pretty half-herbaceous plant from the Himalaya Range, and well-known to gardeners.

The *Abelia uniflora* was discovered by Mr. Fortune, in the

north of China, whence he sent it to the Messrs. Standish and Noble, of Bagshot, in whose nursery-gardens it stood out the severity of the last three winters without any protection, and flowered with them last June. It is well represented in the last January number of the *Botanical Magazine*, where (we are told by Sir W. J. Hooker) it is said to be the same as *Abelia serrata*, described by Dr. Siebold and Professor Zuccarini, in their *Flora Japonica*. The genus was named long ago, by Dr. Brown, in commemoration of Dr. C. Abel, physician to the Embassy to China, under Lord Amherst. It belongs to the natural order of Caprifoliaceae (Caprifoliaceae), and in the Linnæan system to Pentandria Monogynia.

B. J.

Propagation and Culture.—There is not a plant in the whole order of *Caprifoliaceae*, or *Succulants*, as country people call them, that is at all difficult to increase by cuttings or layers, or from seeds, when they ripen with us. All the *Abelias* come very freely from cuttings of the young wood, under the same treatment as *Fuchsia* cuttings in the spring, or in a shaded place, out-of-doors, under a tight hand-glass, after the flowers are over, by the end of June.

Here let me pause, in all seriousness, to recommend to everyone who is at all interested in growing plants from cuttings, out in the open air, at their leisure time, during the long summer evenings, to procure, by hook or by crook, some of those large, cheap, bell-glasses, which were exhibited before the Horticultural Society, last February, and which are in use, so commonly, in all the nurseries and gardens round Paris, where they get them so cheap, that they might have a revolution now and then to smash one-half of them, and still be none the poorer. Just think, for one moment, of a bell glass for 7½d. that would root three hundred cuttings of *Gloire d'Rosamere* rose in three weeks or a month, next August or September, and then be in time for *Calceolaria* cuttings in October, as Mr. Fish recommends; and that, too, with only one-half the care and attention required to get up things by our common hand-lights, which are all good enough for regular gardeners, but no better than a garden-sieve for ladies and amateurs, as the wind drives through and through them, killing the best cuttings ere they have time to prick up their ears after being planted.

The best place for this *Abelia* is a deep, rich, light border, that is well sheltered, and open to the sun. It will require the same general management as to pruning, propagation, and training, as the *Weigela rosea*, *Deutzia gracilis*, the best *Andromeda* (*Leucothoe*), *Pernettyas*, and all that style of choice low-growing bushes.

D. BEATON.

At the meeting, in Regent street, on the 15th Feb., it was announced that Mr. McGlashen's Transplanting Machine would be set to work in the garden of the society on the 2nd of March, and this caused our insertion of the notice at page 420; but the parties were not ready till the following Saturday, and all the Fellows of the Society and their friends, who trusted to the notice in *THE COTTAGE GARDENER*, were unavoidably put to inconvenience. That, and the very wet morning, accounts for the comparatively small number of persons who attended on the 5th. Except a few ladies, half of

the company were gardeners and nurserymen; and of all the meetings that we have attended for the last twenty years in this garden, we never saw so many first-rate planters together, nor so anxious about understanding every move and member of the machine. At the head of this class (first-rate planters) stood Sir Joseph Paxton, who, although he is now rich enough to pay for a passage to Australia for all the gardeners he ever knew, and his company is sought after by all the great and leading men of the day, never thinks of separating himself, at such public meetings, from his old friends

and acquaintances. It is just the same with all the old race of fortunate gardeners whom we happen to know, while they, each and all of them, deplore the vanity and senseless pride and ignorance of a set of would-be-gentlemen-gardeners, who strut about in "kids," perfuming the whole air about them with the effects of their toilets and the affectation of their silly humanity. Then there were the two principal court gardeners, Mr. Ingram, from Windsor, and Mr. Toward, from Osborne House, with Mr. Smith, the Curator of the Royal Gardens, Kew; Mr. Barron, from Elvaston Castle, one of the most successful planters of large trees that ever took a spade in hand; Mr. Glendinning, though not a serving gardener, belongs to the genus of first and most successful planters of the age; he was the first who put correctly the philosophy of transplanting large evergreens. Then, think of such experienced men and critics as Messrs. McArthur, Jackson, Edmonds, Fraser, Standish, Ayres, Duncan, Moore, Hogg, Stevenson, and many more first-rate practicals, all willing to compare their experience with this exhibition, which, as we understood it, was determined upon at the request of his Royal Highness Prince Albert, who was present, with a Highland plaid, which he wore over both shoulders shepherd-fashion in a storm, and was as keen to every move as the most practical among us.

By the time we all arrived at the garden of the society, the apparatus for moving a large, full-grown Poplar was fixed, and the operation of lifting the tree, with a ball of earth, reckoned to weigh nine or ten tons, was commenced by eight strong labourers turning as many screws, and they soon had it up, safe and sound, without moving the tree from the perpendicular, and there it stood suspended to a strong carriage on four wheels, ready to be carried away to a hole not far off; thick planks were then laid for the wheels of the carriage to run on to the hole. The moving of the loaded carriage along these planks was effected by two men working a windlass in the front of the carriage, and winding in through a pulley a rope fastened to a tree beyond the hole. If the tree had to be moved a long distance, the carriage must have been drawn by so many horses instead of by the windlass. When the ball came over the centre of the hole, the two fore wheels were past the hole, and the hind ones not quite up to it; by unscrewing the tackle, the ball was lowered as easily as possible into the hole. There was nothing like a jerk, or shaking about, from beginning to end, and every one acknowledged that the thing was done cleverly.

Now for the principle, and the application of it. Up to this point we have only the principle of the screw involved, and we all know that, by that principle, a church could be moved if there was sufficient strength of machinery applied. As soon as the large tree was up, we could all see, plainly enough, how the lifting was done, but how the rest of the apparatus was applied to the screw principle few of us could understand, because we did not see that part of the process—all that being settled before we entered the garden. But, as is well known, Prince Albert is not to be put off from seeing

the whole working of any new scheme or invention in which he takes an interest; and there is no doubt but he took a very great interest in Mr. McGlashen's machine. No sooner, therefore, was the Poplar out of the ground, than the Prince desired to see the whole process by which the ball of the tree was secured for the gripe of the screws. Consequently, a second, and a smaller apparatus was fixed to a large Sweet Bay, His Royal Highness looking on as intently as any of the grey-headed gardeners. When this was completed, and the rest to be only a repetition of the raising process, the Prince took his departure. The Bay-tree was left in the jaws of the clasping irons, and we all went to see the large tree planted, as I have just said.

The Poplar had the ball secured to the roots on this wise, and just in the shape of an orange-tree or aloe-box, quite square, and wider on the top than at the bottom. If the four sides of an orange-tree-box were separated, and each side split down into six equal parts, there would be twenty-four pieces, of course; then, if you take number one piece, and drive it down in soft ground with a mallet, and leaving six inches of it above the ground, it would stop there while you took the next piece, and pushed it down close after the first, and to the same depth; when the next four pieces are fixed in the same way, we have one side of the orange-tree-box in the ground, all but the little at the top. Now, turn round the corner, and drive in the next six pieces, and we have two sides of the box in the ground; the other two come next, and we have an orange-box, as it were, sunk in the ground, with a few inches of it above the surface. The reason for splitting the box is that it would be easier to drive in one piece at a time than one whole side; particularly if it was a very large box. If it was a small box, of course one could drive down one of the sides whole, and then the box would be got down in four pieces, instead of twenty-four. Well, the second box which was put in to show the Prince how the machine acted was really in four pieces, and they were joined at the corners as they were driven in, two of them having projecting eyes, one at each corner, and these eyes received short projecting teeth, which were on the corners of the other two sides. Then they put an iron rod across the ball, inside this box, with a T at each end of it, just like what a hatter would use to stretch out a new hat. By dint of screwing, this rod stretched out the two sides of the box very much at the top, and the bottoms must necessarily close in upon the ball in the same proportion. After that, the other two sides of the box were stretched out in the same way at the top, and, as consequently, pressed in at the bottom. Now, suppose the sides of this box to be as sharp at the bottom as a knife, each of them must cut all the roots as low as it is driven down; and so the four sides did most effectually; and being now so much closer at the bottom than at the top, they had the ball in their grasp, and when they were pulled up, as if pulling up a box without a bottom, the ball must come along with it, and if there are tap-roots, they must be pulled after the ball till they all snap, and then there is only the weight of ball and

plant to raise. If ever you lift a pot with a Geranium in it, which has been in a border all the summer, the roots, assuredly, have passed down through the bottom, and when you pulled up the pot in the autumn you had to give an extra pull to break the bottom roots. The whole process of raising such a pot is on the same plan and principle as the apparatus for getting up the largest tree in Windsor Forest, only that the bottom of the pot helps to raise the ball whole. The moment the pot, or the largest ball, thus enclosed, is moved half-an-inch upwards, there is no more friction against the sides of the pot, or the ball, let them be ever so deep, all after the first move in a question of power.

The sides that formed the boxes which enclosed the balls for Mr. McGlashen's apparatus are of stout iron, and sharp at the bottom; and in the four-sided, or smaller box, there was a handle to each side in the middle, also of iron, with a round knob on the top, and a powerful labourer with a large beetle drove down each side, by hitting as hard as he could on the iron knobs. When the ground is very hard, and many roots to cut through, two men drive away at the beetles, like two giants, till they drive them home. For a very large tree we must have a very large box to raise a ball, and it is out of all reason to think that even any two giants could knock down one of the sides, as in the last instance, the side being six or seven feet across; but by dividing one side into six pieces, or taking six strong iron pieces instead, sharp at the bottom, with handles and knobs, each piece can be driven down easier, and the six make a side, and twenty-four of them make the four sides, and that is just what were in use on the 5th for this large tree. We may call these separate pieces, spades, with iron handles, the blades a yard long, thirty-three inches of which were driven into the ground; but the real shape of each piece is more like that of a cricket-bat with a wedge bottom. There is an iron projection or shoulder on the handle of each spade, and the spade is driven down with beetles or heavy mallets, until this shoulder rests on the iron frame which connects all the spades and sides, and by this frame two sides are screwed apart first, then the other two sides on the same principle as in the small instrument. The bottom of the tree is padded, to save the bark from the stays, which hold it on the perpendicular, and which stays are set and held together by the working of screws and wedges.

Besides this powerful apparatus, there were others exhibited by the inventor, in different sizes, down to that by which a lady could pull a Heartsease, or Bachelor's Button, out of the ground; and, as far as we could make out, every one present, and certainly the grey-headed gardeners, wished success to Mr. McGlashen and his machines. But whether they, or any of them, would adopt this process in preference to their own ways is more than we can say. We can only answer for ourselves, that the moment we saw it we could see how to improve it, so as to be twice as easy to work, and more safe for the trees.—D. B.

WE consider the following evidence of the power to resist frost possessed by a combination of double-glazing and a well of water, of sufficient importance to merit this prominent position. We advise all persons about to construct greenhouses and cold-pits to retain this evidence in their memory.

"Some time early in the autumn, I sent you a letter descriptive of a cold-pit I was about to construct. The pit was to be placed over a well, and the lights double-glazed. You paid me the compliment of a leader, shortly after, on the merits of double-glazing, and quoted my letter. I have now to report progress. I have a very small forcing-house, a range of small pits, and a two-light frame double-glazed. All but the latter, however, are warmed by hot-water. I have dispensed with all mats for covering. We have had now a sharp frost to test the efficacy of the double-glazing, and you will appreciate the effect, when I tell you that the snow lay on my double glass; while on my single-glazed greenhouse, which is less heated, it melted off. But to confine myself to the pit without the artificial heat. I placed in it six or seven *Cinerarias*, all sickly, for my climate (not two miles from St. Paul's) does not suit them; two plants of *Cytisus*, *Cunlar*, three or four *Calceolarias* (*Kayii*), four common old plants of *Geraniums*, two *Myrtles*, and a self-registering thermometer. The pit is over a shallow well, or rather trap, about four feet circular, into which the various drains across the garden disembogue. The water is about seven feet below the surface. Across the top is an old gate, which forms the stage for the plants. The frame is a two-light cucumber-box, each light being in breadth four feet three inches. The box is sunk to the ground-line of the garden. This pit was closed on the approach of the late severe weather, and has just been re-opened.

"All the plants look as well as they did before the frost, with the exception of one *Cytisus*, which is now dead. I cannot say, positively, whether it was alive or not before the frost, as all the plants were not much cared for, and the chance of performing the experiment was apparently going, and I had, therefore, not taken especial notice of the contents of the pit immediately before its close. On re-opening, the lowest point at which the thermometer had been, was 32°, while outside it was, on one night, below 20°. I consider, therefore, the experiment so far satisfactory, that freezing of the plants has been prevented, and by a deeper well a still higher degree might have been secured.

"The experiment has been still more satisfactory with respect to the effects which the water in the well below might have been supposed to produce, for throughout the winter there has been no loss from "damping off" of any plant; and though I have lost enough this winter, my loss has been much less in this pit than in the others heated by hot-water, so much so, that my gardener, when he saw a promising lot of *Cinerarias* going off in the heated pit, wished to have them put into the cold-water pit in the hopes of saving them. That the plants did better in the latter, I attribute to the more equable temperature, to the less sudden rises and falls in

temperature, to the gradual fall at night in the cold-water pit, all of which cannot be so well managed by hot-water pipes."

W. H. O.

COVENT GARDEN.

ALTHOUGH the weather has been more open during the past week, still the effects of the late frosts have been such as to influence the supplies of vegetables to a considerable extent. This always is a scarce time, but when we have such severe visitations of hard weather as we have had, and particularly after such mild weather as has existed during the whole of the winter, all market-garden produce comes in very short, and not of the best quality. Prices are still high, quite as much so as they have been for the last fortnight. Fruit of all kinds is very scarce; indeed, even *Apples* are almost as short as we reported *Pears* to have been all the winter.

Of the forced culinary articles there is a good supply—such as *Rhubarb*, *Sea-kale*, and *Asparagus*. There are also several lots of *new Potatoes*, and a few *new Carrots*. Old Potatoes of the best quality, such as *Regents*, make as much as £8 a ton, while the inferior and foreign sorts may be had from £4 to £6. The supply of *Cornish Brocoli* still continues, but they with difficulty make more than 2s. a dozen.

Cut Flowers and Plants are very plentiful; they consist of *Heaths*, *Tulips*, *Hyacinths*, *Geraniums*, *Roses*, *Epacris*, *Primulas*, *Violets*, and *Camellias*.—H.

GOSSIP AND GLEANINGS.

IN some parts of Ireland vegetation has suffered more from the late frosts than it has in England, and this has arisen from the absence of snow in Ireland. A clergyman near Cloyne, writes to us, that the consequent injury is very great in the flower-gardens, "so many things were in advance, from the previous mildness of the weather. For twenty years, I am told, there has not been such a frost in this neighbourhood. We have had scarcely any snow, so that even many of the Wall-flowers appear gone." This leads us to remark, in answer to another correspondent (C. F.), that there is no doubt that snow keeps the plants beneath it warm during very severe frost. Snow is a very bad conductor of heat, and the cold above its surface must be very severe before, at an inch beneath that surface, the thermometer sinks below 32°. The following experiments, published by M. Boussinghault, illustrate this fact:—

"In the month of February, 1841, I made some experiments, which show that the snow which covers the ground acts in the manner of a screen. I had first a thermometer upon the snow, the bulb of the instrument being covered, by from 0.078 to 0.117 of an inch of snow in powder; second, a thermometer, the bulb of which was situated completely under the layer of snow in contact with the ground; third, a thermometer in the open air, at about 37 or 38 feet above the surface, on the north of a building. The layer of snow was about four inches in thickness, and had covered a field sown with wheat for a month. The sun shone brightly upon the field on those days when my experiments were made.

"Feb. 11. Five o'clock in the evening; the sun has been hidden by the mountains for half an hour; the sky is unclouded, the air very calm: thermometer under the snow, 32° F.; thermometer upon the snow, 29° F.; thermometer in the air, 36.3° F.

"Feb. 12. The night very fine, no clouds, the air calm. At seven o'clock in the morning the sun is not yet upon the field: thermometer under the snow, 26.2° F.; thermometer upon the snow, 10° F.; thermometer in the air, 26.3° F.

"At half-past five in the evening, the sun behind the mountains: thermometer under the snow, 32° F.; thermometer upon the snow, 29° F.; thermometer in the air, 37.5° F.

"Feb. 13. At seven in the morning; the sky grey, the air slightly in motion: thermometer under the snow, 28° F.; thermometer upon the snow, 17° F.; thermometer in the air, 25° F.

"At half-past five in the evening; the air calm, the sky cloudless, the sun already concealed for some time: thermometer under the snow, 32° F.; thermometer upon the snow, 30° F.; thermometer in the air, 40° F.

"Feb. 14. Seven in the morning, wind W., a fine rain falling: thermometer under the snow, 32° F.; thermometer upon the snow, 32° F.; thermometer in the air, 35.7° F.

"When we reflect upon the losses occasioned to farmers and market gardeners by frosts that are entirely due to nocturnal radiation at seasons of the year when vegetation has already made considerable progress, we ask anxiously if there be no possible means of guarding against them. I shall here make known a method suggested and successfully followed by South American agriculturists with this view. The natives of the upper country in Peru, who inhabit the elevated plains of Cusco, are perhaps more than any other people accustomed to see their harvest destroyed by the effects of nocturnal radiation. The Incas appear to have ascertained the conditions under which frost during the night was most to be apprehended. They had observed that it only froze when the night was clear and the air calm: knowing consequently that the presence of clouds prevented frost, they contrived to make as it were artificial clouds to preserve their fields against the cold. When the evening led them to apprehend a frost, that is to say, when the stars shone with brilliancy, and the air was still, the Indians set fire to a heap of wet straw or dung, and by this means raised a cloud of smoke, and so destroyed the transparency of the atmosphere from which they had so much to apprehend. It is easy, in fact, to conceive that the transparency of the air can readily be destroyed by raising a smoke in calm weather; it would be otherwise were there any wind stirring; but then the precaution itself becomes unnecessary, for with air in motion, with a breeze blowing, there is no reason to apprehend frost from nocturnal radiation.

"The practice followed by the Indians, just described, is mentioned by the Inca Garcillaso de la Vega, in his Royal Commentaries of Peru. Garcillaso, in the imperial city of Cusca, and in his youth, had frequently seen the Indians raise a smoke to preserve the fields of maize from the frost."

Messrs. Nutt, the well-known breeders and judges of poultry, being about to leave York for London, have recently sold their collection by private treaty. Their small, but splendid stock of *Cochins*, have been purchased, principally, by the fanciers in the neighbourhood, at an average of nearly £7 each; we believe a higher average than any public sale has yet realised. They are nearly all the produce of two birds of the pure Sturgeon blood, and are amongst the finest specimens that gentleman has produced. The cock, which now weighs over 12 lbs., and is remarkable for his symmetry and great characteristics of breed, is, together with some of the younger birds, in the possession of E. Bond, Esq., of Leeds. Amongst the purchasers we may mention — Smyth, Esq., of Skelton, near York; W. D. T. Dimsbury, Esq., of Skelton; J. Swann, Esq.,

Askham, near York; G. Jackson, Esq., York; Dr. Hantley, Howden; Rev. H. Hotham, of Ross; and Jas. Braddock, Esq., of York.

R. P. Hill, Esq., of Cradley, in Herefordshire, gives a very good form of protection to early-forced vegetables. He says:—

“Reading in THE COTTAGE GARDENER of February 10, an account of a simple plan for growing early vegetables on manure-beds, the soil being confined by slabs, I think it may not be uninteresting if I mention a plan I have used with great success for covering these beds. I have only used it one year; but a neighbour of mine, who is a large farmer, has tried it with uninterrupted success for several years, having young potatoes always early in May. The plan is to have a frame made of sallow poles, in the same manner as a hurdle, of the size of the bed; this I cover with straw to a suitable thickness, tying the straw down to the frame with tarred string or willow bands. When done with, I used the straw in the stable, and put the frames under the shelter of a tree. I rested the frames on four forked sticks driven in to a suitable height for the plants at the four corners of the bed. I have also a pole about ten feet long, with a fork at the end, with which I prop up the thatched frames to let in sun and air.”

Another correspondent, who signs her note “Queen Mab” (a title well deserved, as the fairy queen, we are told, delighted to revel among the best of flowers), has much gratified us with the following information:—“I noticed in your columns, the other day, an account of *Limnocharis Humboldtii* having lived out in an open pool at Berlin.* If it is any satisfaction to you or your readers, I may mention, that from good authority I understand that both *Limnocharis Humboldtii* and *Nymphaea cerulea*, have been grown in an open tank, in the neighbourhood of Dorking, Surrey, and stood the winter. The only precaution taken was to have the water of sufficient depth to prevent the crown and roots being injured by frost. My informant also told me he believed the *Limnocharis* had produced flowers the previous season to that in which he saw it growing. The tank was brick, southern aspect, and protected on the north side by a wall.”

The Newcastle, Northumberland, and Durham Society for the Improvement of Poultry will hold their next exhibition in the Corn Exchange, Newcastle, on the 30th instant.

MEETING OF THE HORTICULTURAL SOCIETY.—1st. MARCH, 1853.

AFTER a fortnight of frost and snow, in which many parts of the country were buried very deep, although we escaped from it about London, the 1st of March was ushered in, hereabouts, in the most gloomy mood imaginable. It was neither frost, nor snow, nor rain, nor hail, but a mixture of the four, which came down, by noon, as I got to the Waterloo Station, so fast and furious, that I was in a regular mess ere I reached Regent-street, where no one would think of sending flowers on such a day, for love or money, or medals either. Yet we had some very nice flowers; with two good *Pine-apples*, a Queen, weighing 2½ lbs., and a Black Antigua weighing 3 lbs., from Mr. Davis, Oakhill, near Barnet; and a dish of beautiful, new, Black *Hampshire Grapes*, as black as sloes, and as tempting as any fruit could be to taste, from Mr. Forbes, gardener to the

* It was added, that in all probability it might be tried with success in the open air in England.

Duke of Bedford. Large green leaves were cut off with these Grapes, and sent to prevent those who did not know better from thinking they were old Grapes from last year's crop. The grape year usually begins with us in November, but it has been proved, more than twenty years ago, in the neighbourhood of Edinburgh, and I saw this very proof, that from the beginning to the middle of September is by far the safest time of the autumn to begin to force for early Grapes. Now, Mr. Forbes did not send up word to say what time he began last autumn to force those Grapes which he had quite ripe for the table last January, or how he managed them; but the moment I cast my eyes on them at the January meeting, it struck me that he worked them on the Edinburgh plan; and I know that some of the other best grape-growers in England do the same. Therefore, although I told the story in black and white long since, I think THE COTTAGE GARDENER has not yet heard of it, and I may as well out with it once more.

In 1827 I was in Edinburgh, and the general talk, that autumn, among young philosophers of the cabbage-school, was about one of the craft, not far from the city, who got into sad trouble about an early vinery, from which he gathered the last part of the crop in the May preceding, and for a month or two afterwards he had the glass taken off, and when the house was covered early in August they forgot to leave room for air to come in or go out; the doors were locked, and on hot days the heat inside must have been awful to think of; and when a night happened to be very cold, no one knows how very cold this locked-up vinery must have been. After a while, one of the men discovered that the vines were in leaf, the news was immediately conveyed “to Master,” the house was unlocked, and the said “Master” looked as cross as two sticks; the mishap was to be hushed: but it got wing, and we soon forgot Bur's misdoings, and the loss of poor daft Jamie from the streets. Speculations ran high as to what should, could, or ought to have been done, under such awkward circumstances. Sixteen years after this, the story was told to young England; and in ten years after that, new Grapes, and most beautiful Grapes, too, were exhibited in Regent-street; and yet the Londoners looked on the wonder with as much indifference as did the Mandarins on Sir Henry Pottinger's fire-ship in the Chinese waters; so that the whole thing, from first to last, was a kind of forced acknowledgment, that September is the best month, after all, for beginning to force the earliest Grapes; therefore, we must say and consent to it, that September is the beginning of the grape year in our British climate; and that Grapes can now be had fresh and fresh, from one year's end to another, from this “early-closing” of the Scotch graperies.

Green Peas.—We had a large dish of green Peas, in pod, from Mr. Lewis Solomon, of Covent Garden, as good for the cook as if it were the end of May, with *Lettuces* as crisp and solid as if it were the dog-days. The Peas came from Thoulouse, and the Lettuces from near Paris. With these were lots of beautifully-blanching, small-curling *Endive*, *Radishes*, and other salad things, all from under the large bell-glasses I mentioned at page 422. That glass was still in the room, tempting one to take a regular tour through the country to shiver the whole of our old hand-glasses to atoms.

The next novelty was a new *foreign Geranium*, called “The Queen of February,” sent by Mr. Gill, Westbourne Grove, Bayswater; and I took particular notice of it, because I know, full well, what a boon it is to many gardeners in the country to get hold of any gay plant that will bear to be forced into bloom in winter, particularly so if it be a good Geranium. This new comer is a high-coloured one—a bright rosy-pink, with a dark blotch in the back petals; the flower of a better shape than any of

the old forcers, but not a florist's maximum, though not the worse for all that. It is very difficult, however, to make sure of the value of a forcing Geranium at first sight. Most gardeners know that many kinds of Geraniums will flower in winter if they are not cut down at the usual time in the autumn; but then, such plants are well nigh over by this time; but the one in question had only opened the first flowers the week before, and, from the quantity of flower buds, it will keep in bloom to the middle or end of April, and it did not show the least symptom of "drawing" from being forced so early, if, indeed, it had been forced at all. The grower gave it no chance of being fairly criticised. If it is intended to "come out," we ought to have had its history from first to last. I have great hopes of it.

Mr. Young, nurseryman, Godalming, sent three specimens of that beautiful dwarf *Cypress*, called *Govenii*, or *Goveniana*, which I have so often recommended, and which everybody admires. Two of them were in fruit, and the third in full flower, with the pollen so ripe and abundant, that if you shook the plant between you and the wind you would be covered all over, like the "dusty miller," with the yellow powder or pollen. This is the first time, I believe, that this elegant evergreen has been seen in fruit in this country, at least, publicly; and it was a mark of particular attention, on the part of Mr. Young, towards the Society, who introduced this *Cypress*, to go to the trouble to take up these plants, and to pot them on purpose to be sent for exhibition. The two plants with cones on them looked as if they were distinct from the one in flower, they were so much of a darker green colour, but that could hardly be, seeing that it is one of the private marks for these *Cypresses*, that male and female flowers are on the same plant, but on separate parts, like our nut and filbert trees. The fruit cones are dark purple, and about the same size as those of the common evergreen, or Italian *Cypress*, but after you once saw them you could distinguish one of them in the dark, by the feel, from the cones of any other known *Cypress*. The cone, which is nearly round, ends in a sharp point, and there are four more sharp points about the middle of it, at equal distances, thus—

When the scales of a conifer, or cone fruit, end in projections, they call them *murronate* in books; but when the projections are so very sharp, they ought to be called "touch me nots." I have been thus particular to save the column "To Correspondents," in which some say there is no difference between this and the *Cypress* called *macrocarpa*, and that *macrocarpa* is different from *Lambertiana*, which it certainly is not, not even so different as a fruiting plant of *Goveniana* is from one of the same kind in flower.

I saw another curiosity bearing on this subject, the other day, in Mr. Jackson's nursery—the beautiful *Taxodium sempervirens* in flower for the first time in Europe, as far as I know of. This is another Conifer, and, perhaps, the fastest grower of all the evergreen trees we possess. And here is a peg on which I must hang a severe reprimand, in passing, to some first-rate gardeners, who neglect the right management of this *Taxodium*, and leave it to wild nature in our moist climate. We all know the sad effects of allowing the Italian *Cypress* (*Cupressus sempervirens*) to grow up in its own way in our terrace gardens, which way leads to many side leading shoots, and these shoots, after a few years, get so top-heavy, that they all spread out from the pyramid, especially when loaded with snow, or heavy rains, that they must be tinkered and fastened back to the main leader with copper wire, tar ropes, and goodness knows with what other clumsy contrivances besides; whereas, if they were stopped in time, and so kept stopped from year to year, as the tree grew on, we should at least obtain a perfect pyramid of evergreen,

that no wind or violence could make a breach into—the whole sides, from top to bottom, being as close and stiff as a well-kept hedge of holly or hawthorn. It is much the same with this *Taxodium*. In our moist climate it grows out of all bounds in a few years, and in a few more it looks as gawky as a Malay cockerel on yellow stilts; but if you take it in time, and stop the ends of all the side-shoots, keeping an eye to the pyramidal form, it is possible to bring it out as perfect, and compact, and as feathered from the bottom, as Mr. Sturgeon's "Patriarch," or even his "Jerry" himself.

Mr. Barnes, nurseryman in Camberwell, sent six plants in bloom of a ground Orchid, a native of Barbary (*Orchis longicornu*), and they looked as fresh and gay as if they were growing at home. If we could but grow our own native orchids in this free style, what a triumph it would be to British gardening. Mr. Barnes has earned his laurels already for his success in growing plants, and this must be an extra feather in his cap.

Mr. Henderson, of Pine-apple Place, had a beautiful little plant exhibited of the new *Sikkim Rhododendron*, called *ciliaris*. It was hardly nine inches above the pot, yet it was loaded with large blush-coloured flowers. The same kind was shown before us last spring, when I told all about it, but now it looks more of a little man than a seedling, and surely, if all the little men in the world were so gay and tempting, there would be fewer bachelors; at any rate, *ciliaris* should be spoused directly, and to none more fittingly than to *Azalea indica variegata*; the next best would be *exquisita*; after that, the largest and best-shaped of the pure white Chinas. The substance and colour of *ciliaris* are unexceptionable, but to get the shape of it into the fashion it would need a hoop inside, to stretch out the edges a little more; but the first cross with *variegata* would do all that, and improve the foliage wonderfully, and would, probably, render them less liable to the attacks of their natural enemy, the dreadful thrip.

There was a slender shoot, seven or eight feet long, of a small-leaved *Acacia* called *Riceana*, lying across the table, covered all over with the usual golden flowers so peculiar to these graceful plants. It was only a mere feather, plucked off one of the large *Acacias* in the Society's conservatory, and they had a new *Rogiera*, at least, new to me, called *Roezlii*. It is not so good as *Rogiera amana*, mentioned in my last report, but in that style.

There were, also, from the garden of the Society, six kinds of the *Chinese Primrose*, double white-and-red, red-and-white fringed, a good dark red, and a cut-leaved or jagged-flower kind, which I never saw before, all grown in the style of London growers; but the Londoners are a century behind Ipswich and Bath in the growth of this flower. It is quite evident that the strong yellow loam which they use so much about London is entirely unfit for growing this *Primula*; and as to colour, this soil seems to destroy it altogether. A very good grower of this plant, whom I could name, and whose third-rate flowers are infinitely better than the best of them I ever saw in London, never uses a particle of loam at all for them. His compost is made of very rotten vegetable matter and the oldest cowdung he can get, with a good portion, or say a sixth part, silver sand. What we gardeners call the "rubbish heap," or where all the refuse of the garden rots together, is his resource when he wants a *magnum bonum* *China Primrose*; and from the day he sows the seeds till his plants are in full bloom, he never allows the sun to shine upon them for one half-hour; and when he has a plant which he calls a "good un," he never waters it by the surface of the pot, after the last shift, but by a saucer, and the saucer is only allowed to stand under the pot so many hours. What he calls "a free and

easy" way to get into a good stock of them is this—Save your seeds from the best-coloured plants, and those with the shortest footstalk to the leaves; or, if you buy seeds, get it from six different shops, else you may lose six years in getting a good plant. Sow about the middle of April, and before the end of May prick out the seedlings about four inches apart, in a cold frame, under a high north wall, the bed for them being four inches deep, and of sifted stuff from the rubbish heap. When they "prick their ears," or, in other words, when the leaves stand firm and erect after planting, open *both ends* of the frame, not *top and bottom* in the usual way, and allow the lowest current in the air to sweep over them, day and night, and sprinkle them with a fine-rose pot every evening the last thing in hot weather. If the leaves get too close together before they show for bloom, he cuts away the oldest of them, without "stint or spare." Early in September they begin to open their flowers. If it is a good hit, one flower out of fifteen is worth marking as first-rate; at other times, two really good flowers can hardly be got from so many hundred seedlings. All the decidedly bad he pulls out the first moment he sees them, and when a good one is fixed on, the flowers are cut away, the plant is pressed hard down in the soft bed so as to make a better ball by about ten days afterwards, when he pots it, and then shuts it up in a close frame till it overcomes the change. To keep a really good strain, he divides the crown of the old plant in June, and puts the cuttings under a hand-glass out-of-doors behind a wall, and after rooting he pots them about the beginning of September.

But I lose sight of Regent Street and the Society. The best plants from the garden of the Society were the large Nepaul Evergreen Berbery. *Berberis Nepalensis* (in bloom) *Diosma ambigua*, which always flowers thus early, and is therefore one of the most useful of these greenhouse plants; and *Centradenia floribunda* and *rosea*, stove plants, and the only ones of that class they could venture out on such a day. There was also a large plant of a Chinese *Azalea*, with small crimson flowers, and called *obtusa*, which is very little known in country places; also some *Heaths* and *Epaerises*.

The Honble. Mr. Strangways, who never fails in his contributions to these meetings, sent a bunch of cut-flowers from the open air, in Dorsetshire, in which was the Russian *Helleborus*, mentioned in my last report, and in which the name is not rightly given; it is the *Helleborus abschasicus*, a nice blush flower, quite hardy, and well worth having for a spring flower. There were two *Iris*s among these cut-flowers, a very rich deep blue one, with three light markings in the eye, it is called *reticulata*, and is the best in the section of the genus to which it belongs. It is also sent up, year by year, from the same garden, to these meetings, yet no one seems to half prize it enough, while *Iris tuberosa*, the second one in this lot, is, and always was, in everybody's mouth since I remember, although its ugliness is the only redeeming point in its features that I ever could make out. The very large yellow *Auricula*, called after the unfortunate pilot (Palinurus) of Æneas's ship (*Primula Palinuri*), was there, and is a spring flower, highly deserving of cultivation, and looks as if it would cross with the florist's varieties, and a suggestion to this effect was made more than twenty years since, when the plant was figured; but that the race has any of the blood of Palinurus in it is more apocryphal even than the existence of such a personage.

Dr. Bowring sent a large supply of the seeds of the *Tea plant*, from the north of China, to H. Winch, Esq., Seacombe, Cheshire, and this gentleman, very obligingly, sent them to be given away to any of the members at this meeting who might wish to grow their own tea, if they could. Gardeners will understand the looks of them, when I say they are hardly distinguishable from

Camellia seeds. There was a large supply of grafts of new Plums and Cherries given away from the Society's collection. I invite Mr. Errington to look after a new Plum among them, from America, said, in the lecture, to be very good indeed, and as big as a Washington Plum. The name is *Haling's Superb Plum*.

D. BEATON.

JOTTINGS FOR THE GREENHOUSE IN MARCH.

CALCEOLARIAS.—These I glanced at last week. Few things will surpass the large-flowering herbaceous and semi-shrubby kinds in April and May. They thus form excellent forerunners for Pelargoniums. It is very difficult to keep fine plants in healthy luxuriance in-doors in summer, because they cannot thus be kept cool enough. A shady border, out-of-doors, is the best place to bloom those that are raised from seeds sown in spring. To have fine large plants in bloom, in April, the seeds should be sown at the end of July. August and September will do for successions. Shrubby kinds, sown now, will bloom in summer and autumn. As some may wish to sow *now*, I will again repeat the process. Fill pot or pan half full with drainage; cover that with rough material, and then with one inch of light sandy loam and peat, so that when firm there will be half-an-inch between the soil and the top of the pot; then set the pot in a pail of water until drainage and soil are saturated. Allow the pot to drain for a day, then scatter a little sandy soil on its surface; press down level, and then sow the small seed; dust over with a little fine sand, gently press down again, cover the mouth of the pot with a square of glass, over that lay a piece of paper, or any other opaque substance, such as moss, and then place the pot in a shady place, and in a temperature of from 45° to 50°, and little more attention will be requisite until the tiny plants appear, when light must be given them, and air by degrees—pricking them out as soon as it is possible to take hold of them. If the surface soil gets dry, water very carefully; but it is safest to keep the outside and standing place of the pot moist, in preference to watering at all, before the plants are fairly up, and even then it is better to set the pot in a pail of water, and let the moisture rise from beneath, in preference to using either spout or rose above. The same remark applies to all very small seeds. I have already stated that the compost can scarcely be too light and rich; if deficient in old sweet manure, use sandy loam and a little peat, with charcoal to keep it open, and then use manure waterings. Weak solutions of cowdung I have found the best for this tribe, and the water should not be heated above the average temperature. An average night temperature of from 45° to 50° will grow them to perfection; and from 5° to 10° rise from sunshine, with plenty of air, will bloom them well, and secure fine healthy foliage, hanging over and almost concealing the pot. A much higher temperature will bring hosts of insects; and when once a leaf is fairly attacked with green fly its beauty is gone for ever. Never wait to see *two* green flies; smoke whenever the first presents itself: nay, it is advisable to smoke slightly every week, even if you see none. For valuable plants use the best shag tobacco; and, however used, see that the smoke is *cool* before reaching the plants. Tobacco paper, &c., should only be used for robust kinds. As soon as bloom appears set about hybridising, if the flowers are good. One or two pods will be quite sufficient on a plant. I mention this the more particularly, because all the herbaceous kinds are difficult to preserve after blooming; but by the above method seedlings are easily raised, and, if saved from

good kinds, will always furnish a healthy and brilliant display.

CINERARIAS.—I mention these again because they are so useful for adorning greenhouses at all times, except in the hottest summer and autumn months. Green-fly should be looked after in that case. To bloom in October and November, sow at the end of this or the beginning of next month. After June, they may either be plunged or planted on a north border, and inured to full light in September. Sow every month for succession. The beginning of September will be early enough for plants to bloom in May. Approved kinds, designed for specimens in the middle of May, should receive their last shift without delay. The soil should have more loam than the Calceolarias, as if the soil is very light the flower-stems are not so compact. The general treatment has frequently been given. For these pet plants, just as for the Calceolarias, a cool, moist medium for standing on will be an advantage—such as boards or slate kept moist, or covered with a layer of damp moss that has previously passed through an ordeal of water near the boiling point to make sure of giving all snails and insects a quietus.

FUCHSIAS.—Who does not love them? All the ups and ins as to successful modes of culture would require a little volume, and then would, to a great extent, be a repetition of former statements. It is one of the most patient of plants, as it will stand a great amount of cold short of a sharp frost, and during the first stages of growth the heat that would suit a cucumber would not annoy it. Many will have started some plants at least a month ago. Many, with little room, may be waiting to do so. To suit different circumstances, I will just glance at different modes that may be successfully adopted.

1st. Here are some large plants just breaking their buds; they have been kept beneath the stage of a greenhouse, or near a window in a stable or garret, and it is desirable to have abundance of bloom from them, at farthest, by July. Well, merely take off the points and decayed parts of the old shoots, leaving the bulk of the old head untouched; shake the most of the old earth from the roots, dip the roots in a pail of water, allow to drain, and then repot in rich light rough soil, and place, at first, in a shady part of the greenhouse. The object of dipping the roots in the pail is to fill them with moisture, and thus little water will require to be given to the soil until fresh roots freely are ramifying through it. By this mode you will secure a minimum of fresh growth, and a maximum of blossom, and early too, with but little trouble. Of course, as growth proceeds, more light and air must be given. But

2ndly. These old plants may not break regularly, as you wish to have a very handsome specimen, though it should not bloom until September. In that case, cut the plant down to the ground, and when it shoots, select one shoot, or five or six, according as you wish a one-stem pyramid or a bush. In either case, if the shoot threatens to lengthen too much, without throwing out a sufficiency of side-shoots, nip out the point of the leader, but look carefully in time after another one, and see that no side-shoot becomes strong enough to be a rival leader. In these cases, it is best to allow the young shoot or shoots to grow at least six inches in length before you reshift. If you could give the plants, after potting, a bottom heat of 60°, they would grow stronger, and bloom earlier than if confined all the time after shifting to the greenhouse. In both these cases, frequent dustings over the foliage, with the syringe, will be better than allowing the new soil to be saturated before the roots are occupying it. Intermediate cases, as respects cutting-in, will require corresponding treatment. As a general rule, the severer the lopping, the longer you must be content to wait for a dense mass of flowers.

3rdly.—There are a number of plants, from two to three feet high, grown with one stem, pyramidal fashion, last season; and it is wished to have them of the same shape, but much larger, during the present year. Keep this in view in pruning; have three or more buds on your lowest shoots, two in-layers above, and then only one, and shorten the leading point of last year to one-third or one-half, according as you can depend upon its breaking regularly. To secure this latter desideratum in the case of all the buds you have left, syringe the stem frequently with tepid water, and, in obstinate cases, even lay the plant on the ground, turning it round every day. When the young shoots are one inch in length, repot, and keep close, and a little shaded afterwards. Could you put such plants in a house, where they could have a moist atmosphere, and a temperature at night of from 55° to 60° until the middle of June, you might have fine specimens in the middle of July. In a cool, airy greenhouse you would have to wait until August.

4thly.—Here are a number of young plants that were struck last autumn, and have been kept all the winter on the front shelf of a greenhouse, and now they are nice stubby stuff, from six to nine inches high. Now these kept repotted would make very pretty plants by August, even if kept in the greenhouse; but if a bottom-heat of 60° to 70° could be given these plants in February and March, and continued on until the middle of May, splendid luxuriant specimens would be procured by the middle of July; as the moving of the plants from the closeish pit, or house, to the more airy and close greenhouse, would lessen the growing, and give an impetus to the flowering principle. Small plants started now would not bloom so soon, unless they were cramped in their pots, and taken to the greenhouse earlier. Time is thus gained, but care and labour are increased. Let it not be forgotten, that it is only at an early period that this extra coddling with heat will suit; as the plants progress, they cannot have too free an exposure in an open airy greenhouse. Even when coddled with extra heat, they should have no shade, unless when newly potted. I have frequently practised all these modes, and have had very splendid plants from the last method. There are just a few points more.

Propagation.—Young shoots, taken off now, when two inches in length, and inserted in sandy soil, under a bell-glass, and plunged in a medium bottom-heat, will strike root in a few days. These, potted off, kept under glass until June, and then in a sheltered place out-of-doors, will make nice ornaments for the greenhouse from September and onwards.

Soil.—Two parts rough fibry-loam, one dried decayed cowdung or leaf-mould, and one of sand and charcoal, giving more roughness and less sand as the pots and plants increase in size. Drainage must be well attended to. In the case of new and delicate kinds it will be advisable to add peat earth and silver sand. After the plants are in bloom frequent surface-dressings of well decayed dung will be appreciated.

Watering.—After growth has fairly commenced, and the roots are working in the fresh soil, the plants must never suffer from drought. In hot weather they may require refreshing twice-a-day, unless large pots are used. Weak manure-waterings are indispensable to fine foliage and large flowers, but it should not be given so freely until the flower-buds are appearing. I hardly know what is best: I have found guano, superphosphate of lime, sheepdung, cowdung, soot, &c., all good; but err on the safe side as to strength. Three ounces of good guano will do for five gallons.

JAPAN LILIES.—To bloom in the greenhouse in autumn, such as *Lilium lancifolium album*; *L. lancifolium speciosum rubrum*; *L. lancifolium punctatum*, and other common kinds, such as *L. eximium*, *japonicum*, &c. In autumn shows there are frequent discussions as to the

hardiness of the *Lanceifolium* group, and it might be worth while for our coadjutors to settle the matter definitively. As to their fitness for ornamenting the greenhouse there can be no question. For autumn display what can be more gorgeous? Several inquiries have reached me on this subject, but as I could not speak confidently from my own practice, I wrote to Mr. Mackie, gardener at Delafore Abbey, near Northampton, whose fine specimens I had repeatedly had the pleasure of seeing, and that gentleman immediately sent me the outline of his successful mode of culture.

Cause of Comparative Failure.—These Lilies are most effective when grown in masses of from twelve to twenty stems in a pot. Two or three stems present a meagre appearance. Anxiety to increase the stock not only thus militates against the display, but the best bulbs are also apt to be hurt considerably by subdividing them. A simple plan of managing the small bulbs will prevent the necessity of interfering with the larger ones, when not absolutely necessary to reduce the size of the specimens.

Time of Potting.—Remove them from their winter quarters in February or March, just as the bulbs show signs of vegetation.

Mode of Potting: Compost used.—Turn the ball carefully out of the pot, take a pointed stick and displace all the decayed roots and as much of the old soil as possible, without injuring the living roots; at the same time, take the small bulbs from the stem, and such as become detached from the large bulbs, and place them aside in the meantime; then have suitable pots ready, well drained, with a good handful of moss over the drainage. The compost consists of two parts of turfy peat broken into lumps, one quarter part of fibry loam, and the remainder of that part well-decayed leaf mould and silver sand.

The size of pot depends upon the number and strength of the bulbs. A pot fourteen inches across will accommodate twelve bulbs, and sustain throughout the season from eighteen to twenty stems of blossom. For a single, large, very fine bulb, a nine-inch pot will be found sufficient. Having determined on the pot, proceed to place a portion of the compost above the moss and drainage, arranging it so that the upper surface of the bulb is at least three inches from the surface of the pot. This distance enables the *stem* to find nourishment for the large mass of roots which it produces, and which I look upon as the main support of the flowering process. The bulb is then covered with the compost, but not finally, as lumps of peat are placed round the advancing stem during the early part of its growth, as often as rootlets are observed; and this, with me, is sometimes continued until the soil is two inches above the level of the pot.

General Treatment.—When potted, place them in a cool vinery, cold pit, or other cool structure, where they may be free from frost. Forbear watering until growth is visible. Let them so remain until danger from frost is over in May or June; then place out-of-doors in a sheltered place; water freely, according to their wants, and let them, as much as possible, have their own way, until they have matured their growth, and are showing their blossom buds. By that time they will be from four to five feet in height, richly clothed with fine dark green lance leaves, and promising from six to fifteen flowers to each stem. Neat stakes are then used (not before) to bring the stems into an upright position, and the plants are removed into the conservatory to mature and expand their lovely blossoms, reward the labours of the cultivator, and to gratify, by their perfume and contrasted tints, the cultivated tastes of those whose love of the beauties of nature is well exhibited by the admiration they bestow upon these lovely stars of earth.

Young Offsets. These are placed to the number of

six or eight in a nine-inch pot, and treated in all respects like the older bulbs. The first year after such treatment they will flower, and by *avoiding sub-division* at potting-time a stock of good massive plants may soon be obtained.

Winter Treatment.—When done flowering, let the stems remain until quite dead, or even until potting time. Place the plants in a cellar or other convenience free from frost. Keep them *dry* the whole time they are at rest.

Mr. Mackie states, in conclusion, that he will be happy to give his out-door experience of these bulbs, and I am sure that Editor and readers will be obliged by his sending a paper to head-quarters on the subject.

R. FISH.

PRESERVATIVE WALLS.

(Continued from page 423.)

LIST OF SUITABLE PLANTS.

GARDENIAS.—It may startle some of my readers that I should recommend any of the species belonging to this genus as suitable plants for a wall of this description, yet I have no doubt the species mentioned below are more hardy than is generally supposed. A heated glass-covered wall, I am quite sure, would be warm enough for them. At Pine-Apple Place we always kept them in cold frames, or pits, through the winter; and in such structures they may be seen now looking healthy and well. They are protected from frost by coverings of mats and straw. As this is a certain fact, that they are hardy enough to bear such a treatment, surely they will thrive in a conservatory, especially when their roots are not confined in a pot. Their fine foliage, and splendid, sweet-scented flowers, would make them highly ornamental for such a purpose. They would, it is true, bloom later in the season, but their flowers would even then be highly acceptable. The species suitable are—*Gardenia florida* (Flowery G.); the varieties are—*G. F. Fortunei*, *G. F. intermedia*, and *G. F. latifolia*, and *G. radicans* (Rooting).

HABROTHAMNUS FASCICULATUS (Bundle-flowered).—This fine shrub is peculiarly well adapted for this purpose. The flowers are produced in terminal clusters, and are of a rich soft crimson colour. They are about an inch-and-a-half long, and of a tubular shape. The plant is nearly hardy, but will not bear a full south exposure. There are some other species, but not so handsome as the above.

HELMIA MYRTIFOLIA and **H. SALICIFOLIA.**—Two half-hardy shrubs, with neat foliage, and pretty yellow flowers, very little known, but well worthy of cultivation.

HOVEA CELSII (Cel's Hovea).—A beautiful blue flowered shrub, easily raised from seed, which is produced plentifully every year. In pots it is apt to become straggling and unsightly, but against a sheltered wall it may be managed so as to be clothed with branches down to the ground; the colour of the flowers is a most exquisite blue.

JASMINUM GRANDIFLORUM (Large-flowered Jasmine).—This plant is imported annually in great numbers by the Italian warehousemen in London, grafted upon the common Jasmine (*Jasminum officinale*). It is hardy enough to live under glass without heat, but thrives and flowers better if planted against a wall heated with hot-water. The large corymbs of white deliciously-scented flowers which it produces render it a universal favourite.

LUCULIA GRATISSIMA (Most Welcome L.).—This plant is usually grown in a cool stove, which is a great mistake, for it is nearly hardy, and would do well planted against a hot wall covered with glass. It would lose most of its leaves in winter, but would soon produce

fresh ones in the early summer months, and then flower profusely in that season. There is another species named *L. Pinciana*, which is shy to flower in pots, but against a wall would flower as freely as *L. gratissima*.

MAGNOLIA.—A well-known noble tribe of shrubs, nearly all hardy. In the northern parts, *M. conspicua*, *M. obovata*, *M. fuscata*, and *M. odoratissima*, require the protection of a preservative wall, where their handsome flowers will be protected from late frosts. Even in the south these should be planted against a wall, together with the evergreen noble-leaved *Magnolia grandiflora*, and its varieties.

MELALEUCA.—A genus of evergreen plants, chiefly from New Holland. Several of the species are suitable for a wall, protected without heat, being as hardy as the common Myrtle. Their foliage is neat, and flowers handsome; the latter are produced in bundles round the young shoots, and are often termed the "bottle-brush flower," from the form they assume when in bloom. I have selected the following as being the most appropriate for the purpose—*M. callistemonea*, *M. fulgens*, *M. lanceolata*, *M. thymifolia*, and *M. virgata*.

MELIANTHUS MAJOR.—An old inhabitant of our greenhouses, but nearly hardy if planted against a wall. The leaves are large, and beautifully silvered over. Though the flowers are not brilliant in colour, yet, where there is plenty of space, one plant at least is desirable. I once had some seeds sent me from Africa, named *Melanthus major coccinea*; but, unfortunately, they have not yet flowered. I sent a plant to the Regent's Park Botanic Garden, where I believe it is yet in existence. Should it ever bloom, and produce scarlet flowers, it will be a great acquisition.

MITRARIA COCCINEA (The Scarlet M.)—A shrub lately introduced from Chili, and now, from its being so easily propagated, become common. It is hardy enough to plant against a wall, with the protection of a glass covering, without artificial heat. The flowers are of a pleasing bright scarlet, and are showy, and produced very numerous when the plants become large and aged. This will be a great favourite when its merits are better known.

MYRTUS COMMUNIS (Common Myrtle)—Though this beautiful shrub, and all its varieties, are hardy south of London, yet in the north it is rarely seen in the open air. Planted against a wall covered with glass, it will bear several degrees of frost without injury, provided the leaves are kept *dry*, and the roots partially so. It is moisture—excessive moisture—that destroys our half-hardy plants in wet situations.

OLEA FRAGRANS (Sweet-scented Olive)—The flowers are most highly perfumed, though small and inconspicuous. It is a native of China, and only requires to be kept from frost, and is, therefore, a suitable plant to place against a preservative wall, chiefly for its fragrance. The leaves are large, and beautifully toothed at the edges; so that, though the flowers are not showy, yet the delicious fragrance they emit, combined with the handsome foliage, render this Olive a worthy plant.

PHOTINIA SERRULATA (Saw-leaved Photinia)—A fine evergreen shrub, sufficiently hardy to endure our ordinary winters in the southern counties, but north of London requires the protection of cold glass-covered walls. There are some other species of recent introduction, and these are also shrubs with fine foliage. They are named respectively, *P. arbutifolia* (Arbutus-leaved), from California; *P. dubia* (the Doubtful), from Nepal; and *P. integrifolia* (Entire-leaved), from the same country. These are yet extremely rare, but I believe Messrs. Osburn, of the Fulham Nursery, possess them all.

T. APPLEBY.

(To be continued.)

THE PELARGONIUM.

(Continued from page 443.)

SUMMER TREATMENT OF TWO-YEARS-OLD PLANTS.—After having carried these plants safely through winter, the amateur will be anxious to know what he is to do to them the spring following. Plants of this age should be low and bushy, and full of healthy foliage, with eight or nine, or more, branches to each; but it is not advisable to have too many, so as to crowd them, leaving no room for them to expand their leaves. Supposing them in this desirable condition, they should be repotted into their blooming-pots, a final shift previous to exhibiting them. Some Societies confine the exhibitors to the size of the pots, and as this is generally known, the cultivator should place his plants in the size of pots required. The London Horticultural Society has hitherto offered prizes for collections growing in 8-inch and 11-inch pots, and I believe the Regent's Park Shows are required to be in the same sizes. The sizes for 1853 may be ascertained by writing to the Secretaries of each Society.

At the time this meets the eye of the reader it will be the season to place the plants in these pots. The same soil should be used as described at page 424, and the same method of potting the strongest and largest plants should be chosen to put in the largest-sized pots. In potting, care should be taken that the pots are not filled up to the brim with soil, because, as the season advances, they will require water in such abundance, quite through the ball of soil, that if the pots are quite full of soil that effect will not take place, the water will run off over the sides of the pot, and the centre of the ball will remain dry and parched. To prevent this, at the final potting leave half-an-inch of space between the surface of the soil and the top of the pot; this will hold a sufficient quantity of water to thoroughly wet the entire ball quite through, or, if there is any doubt of that being effectually accomplished, a second watering, given immediately after the first has settled, will be sure thoroughly to wet the soil. This thorough watering is infinitely better than the dribbling system of giving a little at a time and often, a system which destroys more plants than any other bad point of culture. At the time of repotting it will be most convenient to tie out the plants anew, and as this will be the last opportunity to do this, great judgment must be exercised in the performance; calculation must be made as to how much room each branch will occupy when the trusses of bloom are fully expanded, and a sufficient space allowed for them; this will save much subsequent trouble and difficulty. The form the whole plant should assume, when on the exhibition table, should be, as it were, foreshadowed in the mind, and the training carried on accordingly. A very few years ago the fashionable form was as if the top of each plant had been bevilled off with a pair of shears. The longest shoots were at the back of the plants, and the shortest in front, so that if the plant was turned round there was nothing to be seen but naked stems and a forest of sticks! This absurd fashion has happily disappeared, and the plants now appear on the tables at the exhibitions in the more natural form of a round-headed dense bush, with the tallest branches in the centre, and the rest gradually spreading out, down to, or even below, the rims of the pots. This is a great improvement, which the good taste of the exhibitor, the judges, and, let me add, the visitors, has induced to become indispensable to a well-grown Pelargonium.

Let the new beginner exert his skill in training his plants from the first stopping of his young plants to bring them into this improved form. The foundation for it must be begun at the earliest stage, as it will be a difficult matter to accomplish so desirable a form when the plants have attained any size.

The season for blooming these really lovely plants generally extends through the months of May, June, and July, but such plants as bloom in full perfection in May, will be quite out of bloom for the July shows, therefore it will be necessary to have at least two sets of plants to be able to exhibit at the shows at the beginning and the end of the season; or if the cultivator only intends to exhibit at one, whether early or late, he should take his measures accordingly. For a May show the plants will require a little forcing, and for the July show they will require to be retarded. It will be difficult to exhibit at such extreme points of the season with one greenhouse. A cold pit will be necessary for the latter month. In it the plants should be placed early in April, and plenty of air given, with a due amount of shade to prevent the heat of the sun hurrying them on into bloom before the time. With such an useful adjunct, and due attention, the plants may be retarded so as to be in the greatest perfection on the very day they are required. For the June show there need be no particular attention bestowed, because the natural heat of the season will bring them on sufficiently (with the ordinary cares of watering, giving air, and shading when the sun shines too powerfully) to be in the finest bloom by the middle or latter end of that month.

These various turning points of culture may appear to the tyro in Geranium growing to be sufficiently tiresome and minute to be attended to for so long a period as two years; but he will find, if he neglects any one point, that his attention in all the rest will be nullified and useless for the purpose of winning a prize at a respectable exhibition.

T. APPELBY.

(To be continued.)

CARROTS ON GROUND NOT ADAPTED FOR THEM.

NOTWITHSTANDING the advances made in Horticulture of late years, there are some productions which are yet difficult to cultivate in many gardens where other crops attain to great perfection; and though it would be unreasonable to suppose that those uncertain ones might be the progeny of parents from a warmer and more congenial climate, yet, in the case now before us, as well as in several others, this plea cannot be urged, for the original is of British growth; but cultivation, when carried to great perfection, is so often accomplished by a sacrifice of the plant's hardihood, that we must take it for granted that this forms one of that class, for though the wild Carrot is yet to be found in our fields and other places, very probably in as great number and perfection as when it first attracted the notice of a semi-barbarous people as an article of food, yet the many generations that have since assisted in its improvement have passed away, and left it with an impaired constitution, unable to support itself in soils not exactly suited to its wants, while its ancestors were less fastidious that way. Now, that this state of things is the result of successive "breeding in-and-in," will be admitted by all; neither have we any reason to find fault, when the improvement in that part of the vegetable most serviceable to us is taken into account; because a similar sacrifice has been made in most of our common fruits which are indigenous with us, or rather their parents were so; and, if we are to believe all that has been written of late, it would appear that the most important of our "Cereals" have a near relationship with some of our commonest weeds. Although the *Daucus carota* is found wild, even now, in many of our fields and lanes, yet its forked gnarly root contrasts strongly with the cultivated article from the most favourable districts, which, for distinction, we will

call that deep alluvial loam so common on the margin of rivers and other low places at the base of hills, where the accumulated debris of countless ages has deposited a mass of matter, at once grateful to this crop and others which delight in a soil of this kind, but as it does not always happen that every garden possesses such a soil, the nearest approach that can be made must be effected with such materials as come to hand in the greatest abundance.

Let us suppose the soil to be operated upon be one of that class of stubborn clays or heavy loam, which, though capable of producing abundant crops of many things, are certainly not the kind best adapted to produce a heavy crop of good useful Carrots; but as the space required for this purpose in most ordinary gardens is not large, it would certainly be worth a little trouble to prepare the ground beforehand for this crop, which may be done by digging in large quantities of loose opening matter, as road scrapings, gritty sand from a river, or other place where water has washed out all its pernicious qualities; pit sand may also be used, but we are not so partial to it as to river or drift sand. Now, to these may be added "brick-dust," or, what is still better, "charcoal-dust," with any reasonable quantity of stone chippings that can be had, even chips of wood are not without their uses; and, in some cases, saw-dust has been used with advantage. But we are not advocates for lime or chalk, which in so many other instances are the best pulverizers of stiff soils; but the latter may be used with great advantage if done so the year before the crop. We have seen a successful experiment with a copious dressing of an opposite ingredient on stiff retentive soil, which was peat or bog earth dug in rather liberally. This substance, however, ought to be added the year before, likewise, as its combination with the soil is slow.

When, therefore, the crop of Carrots is a desideratum, worth sacrificing something for, we advise having a piece of loose open ground which has been digged or trenched as deep as its staple will allow with safety; or, in other words, ground for Carrots ought to be trenched two feet deep, provided the soil be good at that depth; but should it not be so, then trench it as deep as it is good, and keep what had previously been the top spit to the top again, and dig into the bottom part some good rotten dung, or other enriching matter, which will, in addition to affording nourishment to the descending fibres, likewise keep the ground open and porous. The top portion, if tolerably rich by previous dressing for former crops, had better not have any additional supply for this; but any of the substance named above may be dug in to lighten a stiff or retentive soil. This being done, it will be in a condition fit for sowing as soon as the top becomes so mellowed down as to rake in tolerably well, which, however, is seldom the case until it has had some severe weather upon it, as sharp frosts, successive dry, cutting winds, or other mellowing influences;—the first-mentioned performing that duty quickest.

We will suppose that everything has gone on well, and that the ground is in pretty fair order for sowing by the beginning of April, which is quite soon enough; preparations must then be made for it, which is done by simply drawing drills a foot apart, as shallow as will just allow the seed to be sown, and covered half-an-inch deep. This season, however, threatens not to allow this kind of work to be done in all cases; therefore, when waiting to get upon the loose ground seems impracticable, without treading it too much, it will be better to dig a portion and sow a row or two, and then dig again, standing always on the undug ground. This process of digging and sowing simultaneously is very appropriate to ground so stiff and stubborn as a great deal of it is after a wet winter like

the past one. A very smooth-raked surface is here out of the question, neither would it be advisable, as an open surface will let in the frost or drying winds, which do good prior to the seed vegetating, while there is a prospect of its becoming much closer before it does germinate by the causes above, as well as by rain. When the ground is obliged to be dug up very rough, and, to a certain extent, wet also, it cannot always be broken up so fine as even to allow the seed to be covered with anything like regularity. Where such is the case, it is better, therefore, to mark out the line of the drill, and then scatter some fine, dry compost of an open friable nature, in which the seed can be sown with ease, and covered up with the same; while the understratum, and, in fact, the whole ground, will derive all the benefit of the season, by being allowed to remain rather loose and hollow, to admit the air, &c.; and towards the beginning or middle of May, when it becomes sufficiently dry to bear treading on, and the rows of plants are visible, the intervening spaces between the rows ought to be stirred with a Canterbury hoe, or other tool, which will assist to consolidate the substratum by the fine matter running into it, while the top is receiving the benefit the admission of air extends to it. The thinning of the crop may also be proceeded with at the same time; and, in fact, this earth-stirring process must be performed several times during the season, until the size of the tops will no longer allow it to be done without injuring them.

I have not said anything of the kind most proper to grow, but most people prefer the *Early Horn*, for its good table qualities; but it certainly does not keep so well as the larger long sorts; it would, therefore, be advisable to sow a portion of both. The *Altringham* is a good carrot, though not better than the *Surrey*, from which it differs in the smallness of its shoulder or crown. The *Long Orange* is sometimes sown; but when the *Horn* is grown, the eating qualities of the two presents so marked a difference as to lead to a conclusion that the *Orange* is no longer worth garden room; nevertheless, it ought not to be despised, for it usually crops well, and that is important where this production is uncertain, as it often is in places where other crops present an appearance of luxuriance, as a proof of the ground being all that could be desired, while this is only indifferent. But if our remarks tend to enlighten the inexperienced in avoiding the evils noted above our purpose is served.

J. ROBSON.

THE PINT O' ALE.

By the Authoress of "*My Flowers*," &c.

I AM now going to present my readers with a true picture of the good effects of sobriety, as shown in the conduct of a good wife. It has not passed under my own observation, but it is given in a very valuable and interesting lecture upon Popular Insurance, delivered before the Becher Society at Stourbridge, by the Rev. J. B. Owen, M.A.; and I am so desirous of impressing the advantages of temperance, and the dreadful effects of drunkenness, upon all my readers, but more particularly those in humble life, that I shall copy the tale out word for word, and hope it may, by the blessing of God, touch and edify them. At the same time, I wish to lay great stress upon this point—viz., that for worldly reasons sobriety does nothing for the soul. If a man leaves off drink for a worldly reason, it does him good in a worldly way, and it does good to society in general; but unless he leaves off drinking because it is a sin—and sin is hateful in the sight of a pure and holy God—the man in no way glorifies God by turning from it. His soul is drunken with iniquity, although his body is sober; and "what shall a man profit if he gain the whole world, and lose his own soul?"

"The writer heard a story in Manchester of a calico

printer, who on his wedding-day was persuaded by his wife to allow her two half-pints of ale a day as her share. He rather winced under the bargain, for, though a drinker himself, he would have preferred a perfectly sober wife. They both worked hard, and he, poor man, was seldom out of the public-house as soon as the factory closed. The wife and husband seldom saw much of each other, except at breakfast; but as she kept things tidy about her, and made her stinted, and even selfish allowance for house-keeping, meet the demands upon her, he never complained. She had her daily pint, and he, perhaps, had his two or three quarts, and neither interfered with the other, except that at odd times she succeeded, by dint of one little artifice or another, to win him home an hour or two earlier at night, and now and then to spend an entire evening in his own house; but these were rare occasions. They had been married a year, and on the morning of their wedding anniversary the husband looked askance at her neat and comely person with some shade of remorse, as he observed, 'Mary, we've had no holiday since we were wed, and only that I haven't a penny in the world, we'd take a jaunt to the village to see thee mother.' 'Wouldst like to go, John?' said she softly, between a smile and a tear, to hear him speak so kindly—so like old times. 'If thee'd like to go, John, I'll stand treat.'

"'Thou stand treat,' said he, with half a sneer; 'hast got a fortune, girl?'

"'Nay,' said she, 'but I've gotten the pint o' ale.'

"'Gotten what?' said he. 'The pint o' ale,' said she.

"John still did not understand her, till the faithful creature reached down an old stocking from under a loose brick in the chimney, and counted out her daily pint of ale, in the shape of 365 threepences, i. e., £1 11s. 3d., and put it into his hand, exclaiming, 'Thee shall have thee holiday, John.'

"John was ashamed, astonished, conscience-smitten, charmed, wouldn't touch it. 'Hasn't thee had thy share? then I'll ha' no more,' he said. They kept their wedding-day with mother, and the wife's little capital was the nucleus (that means, anything round which other things gather) of a series of investments, that at last swelled into a shop, a factory, warehouses, country seat, a carriage, and, for aught I know, a Liverpool mayor."

See, my readers, what drink destroys, and what soberness builds up. Drink, above all, destroys the soul; and soberness, though it cannot save it, yet it keeps the senses clear, and does not hedge up our way with thorns, so that the truth cannot enter. The mind of the drunkard is stupid and besotted, and the "still small voice" cannot wake him up out of the sleep of death.

I think my readers will be struck and confounded as much as John was by his wife's stocking, if I copy out another passage from the same instructive lecture. Perhaps they do not know, and have never thought about what drink does in this Christian land. Mr. Owen goes on to say, "Drink is the desolating demon of Great Britain. We have spent in intoxicating drinks during the present century as much as would pay the national debt twice over! There are one hundred and eighty thousand gin drinkers in London alone, and in that city three millions a year are spent in gin! In thirteen years, two hundred and forty-nine males, and one hundred and eighty-three thousand nine hundred and twenty-one females, were taken into custody for being drunk and disorderly. In Manchester, not less than one million a year is spent in profligacy and crime. In Edinburgh there are one thousand whiskey shops; one hundred and sixty in one street; and yet the city contains only two hundred bread shops! Of twenty-seven thousand cases of pauperism, twenty thousand of them were traceable to drunkenness. In Glasgow, the poor rates are one hundred thousand pounds a year!" "Ten thousand," says Alison, "get drunk every Saturday night, are drunk all day Sunday and Monday, and not able to return to work till Tuesday or Wednesday. Glasgow spends one million two hundred thousand pounds annually in drink; and twenty thousand females are taken into custody for being drunk." "As to the insanity arising from drink," the Bishop of London states, "that of twelve hundred and seventy-one maniacs whose previous histories were investigated, six hundred and forty-nine, or more than half of them, wrecked their reason in drinking.

As to pauperism, it is estimated that not less than two-thirds of our paupers are the direct, or indirect victims of the same fatal vice." "The immense power in the hands of the working men to promote their own social comfort and independence, is proved by the fact, that they are spending *fifty-seven millions a year in ardent spirits, beer, and tobacco!* equal to an income of sixteen shillings a week to nearly one million four hundred thousand people! Surely, if so much can be spared for the indulgence of bad habits, a tenth of it could be easily diverted to the cultivation of good ones."

Now, my dear Readers, I beg and pray you to read and think these things deeply and seriously over. Perhaps you have never considered what money *you* have wasted, and more than wasted in drinking and smoking! Think of God's gifts abused! the means he has given you for food and clothing turned into soul-destroying sin—the abominable thing that the Lord hateth! Oh! do think of these things, and that when you murmur against "the times," the masters you work for, the rulers who govern you, and *sometimes* the gracious God who has made you, and redeemed you, you have far, *far* more cause to condemn yourselves, your evil ways, and your love of beer, gin, and tobacco!

A very loud cry goes up to heaven for this one thing—the sin of drunkenness. It brings on hundreds of other sins, and sinks unnumbered souls in hopeless perdition. Oh! be assured that the crime carries its own curse to body and soul, and that sin forsaken because it is sin, and hateful to the God of our salvation, will bring abounding blessings into your bosom.

Do not leave off drink because you are starving, but because you are *sinning*, and your soul going down into hell. Do not leave off drink because you want to grow rich, and have a shop, or a country house, or a carriage, but because you want to *grow holy*, and gain an inheritance that fadeth not away. Worldly soberness will secure, probably, "the life that now is," but it is only godly soberness that will secure "that which is to come," and then only for the sake of One who has covenanted with the Father to bear the sins of many, and "to save unto the uttermost those who come unto God by him." Readers, high and low! think of these things!

FEATHERS.

(Continued from page 401.)



THE LACED FEATHER.

A MORE appropriate name for this, we think, would have been the "fringed feather," as the name alludes to the narrow edging around it, but the name of "laced" has been

long-established, and that would be a conclusive reason against any change, even if it were not sufficiently correct.

There are two varieties, "the golden-laced," and "the silver-laced," and in either the body colour of the feather, whether yellow or white, should be perfectly free from "splashing;" that is, without any other colour upon it, except its edging or lacing. The more regular that lacing is in width, and in colour, the more clearly defined its edge, and the more completely it encircles the feather, the more perfect it is to character. At the top, and near the base, it is usually rather wider.

The Gold and Silver Bantams are the birds with whom lacing becomes the main characteristic of their plumage, for when found in other varieties it is only partially developed. Thus the greater wing-coverts, and some other feathers, of the Gold and Silver Polands, are often laced; but a Poland "*laced throughout*" we have never yet seen. Combinations of the lacing with the spangle often occur, to the detriment, as we think, of the effect of both.

ROYAL AGRICULTURAL SOCIETY OF ENGLAND.

A WEEKLY Council was held at the Society's House in Hanover-square, on Wednesday, the 16th of February.

EXPERIMENTS IN POTATO CULTIVATION.—Dr. John Malfatti, of Kuenigberg, near Hietzing, in Austria, transmitted to the Council the following communication, dated the 20th of November last:—

"According to our views, the cause of this disease, though accounted problematical, lies in the decay and degeneracy of this plant in respect to its double sex, the twofold stock from whence it springs. During the growth of the Potato, a remarkable and instructive observation offers itself to us at once, between the two most distinct acts of the double sex of the plant. The first of these acts is that of its internal principle of self-propagation, and predominates particularly during the period of its development. The second act, on the contrary, is a consequence of the first, and consists in an external reproduction, and conduces to the preservation of the original stock. Whilst now the first act always takes place regularly, and, indeed, under adverse circumstances, knows of no disease, we perceive the disease in the second act, on the contrary, suddenly break out, as if the double sex of the plant rapidly became weakness itself, and instead of being followed by reproduction, were followed by degeneracy and destruction. It has long been hoped that the disease in question would turn out an accidental and temporary one. But alas! the contrary has proved to be the case; and there is no doubt but its propagation solely proceeds from a sexual cause, whereby it assumes the distinct character of a disease of race. Though we have come to this melancholy conclusion—a conclusion as painful in respect to the present as it is menacing for the future—Nature, that beneficent mother, comes to our relief with a sovereign remedy—a remedy which she has raised indeed to the rank of a law—namely, that remedy which she has provided both as a cure and a preservative, by means of the sexual crossing of races, and that, indeed, as well in the vegetable as in the entire animal kingdom. This provision of nature is manifestly so excellent, that human art has endeavoured to employ it in both kingdoms, and has done so with the greatest advantage. Taking this point for granted, I endeavoured, as inoculation was a thing out of question, to remove this disease by crossing the Potato with other plants, and, indeed, as it were, by means of a sort of matrimony. The three first Potatoes on which I tried this experiment I paired and enclosed severally with the *Helianthus tuberosus*, the *Dahlia variabilis*, and the *Cyclamen europeum*. For a fourth matrimonial alliance I was indebted to chance; and although this was with the *Carduus hispanica*, which does not belong to the genus of bulbous plants, it was attended, notwithstanding, with the most interesting results. The means thus employed terminated in results which, in a most surprising manner, confirmed the truth of the principle which we first laid down. The longing of the Potato for union with some plant of a kindred sort, manifested itself in the most distinct

manner. Truly we cannot be surprised, if we consider, that since the time this American plant was brought to Europe it has existed in a perfectly isolated state, without enjoying any mutual relation with kindred plants found in our part of the vegetable kingdom; whilst, on the other hand, the art of Europeans has in all kinds of climates increased the production of the Potato to an interminable extent, carrying it even to such an extent as to exhaust its double sex. The product of this matrimonial connexion was most surprising. From the pairing of two plants a third proceeded, retaining, however, a twofold character, the character of each. Their roots, bulbs, and stalks, had grown together, so as to be interwoven one with another in such a manner that it was very difficult to separate them one from another when taken out of the ground. The last Potato harvest presented the most interesting results, as will appear from what follows. Whilst in my neighbours' fields the disease prevailed as before, and I myself lost a good third part of the Potatoes which I had planted on the borders of the field in which my experiments were made, to my great surprise I found not among them a single trace of the disease, although the whole quantity amounted to seven bushels (Matzan). Together with the advantage of restored health, we obtained at the same time another benefit equally important, viz., that of a considerable improvement in the race of Potatoes. Not only was this new breed distinguished for beauty, size, and richness, but the general insipidity and mealy taste of Potatoes has been, by the communication of the aromatic flavour and peculiar taste of the plants with which they were combined, changed into something of a very different kind and of a superior quality. This was most obviously the case with the Potatoes combined with the Carduus (they tasted like Artichokes). In those combined with the Cyclamen, there was a pungent taste, as if they had been slightly peppered; in those combined with the Dahlia, there was a sweet taste like sugar; whilst the Helianthus imparted to the Potatoes combined with it its own agreeable and peculiar flavour. In respect to the management requisite in forming the four above-named species of combination, we remark as follows:—

"1. The Potatoes are, as usual, cut into several parts before they are planted (according to the position of the so-called eyes), and are placed in the earth quite close to the germs of the plants with which they are to be combined. The bulbs of the Helianthus and the Dahlia are cut just in the same way as those of the Potato. The bulbs of the Cyclamen alone remain uncut. As the Carduus has nothing but a root, the cut pieces of the Potato are only planted under its root.

"2. In the two harvests, we perceived that the bulbs of the Helianthus were to those of the Potato, in respect to number, as 3 to 2, whilst those of the Dahlia and Potato were equal. Here we must observe, that these two plants, combined with the Potato, continued growing without interruption, as usual, up to the time of blossoming, whilst the contrary was the case with the Cyclamen and the Carduus.

"3. But the combination with the Cyclamen was the most remarkable of all. This wild plant exhibited so little of itself, that for a long time I considered the trial unsuccessful. The same thing happened with the Carduus and the Cyclamen, some single leaves of which appeared here and there close to the stalk of the Potato, but somewhat sparingly. But so much the greater was my astonishment when, in digging up the Potatoes, I found in that very part the finest and most abundant crop: as if both the said plants sacrificed their growth in favour of that of the Potato, the Cyclamen sacrificing still more, even its health as well. We perceived, indeed, that each of the Cyclamens had two, three, or even four bulbs diseased to such an extent as to be rotten. As this disease presented symptoms perfectly similar to those of the Potato disease, we were irresistibly led to inquire whether or not the Cyclamen had attracted to itself the very essence of the disease of the Potato. On this occasion I delayed not to inquire of skilful botanists whether the Cyclamen, which is generally used in feeding cattle and pigs, was subject to this disease, and the answer was a unanimous negative.

"4. As I was accustomed every year to plant a great quantity of Carduus roots, I was induced to combine them with Potatoes, the result of which surprised me the more,

because they do not belong in the least to the bulbous genus. Just for this very reason, a peculiar result followed, the combination being succeeded by a purely parasitical life. The Potatoes clung so firmly to the Carduus roots, that they actually grew to them, and, as real leeches suck blood, extracted out of the roots all the juice and flavour. In consequence of this, the Potatoes (like parasitical plants) not only attained the utmost development, both in respect to size and beauty, but what was very remarkable, scarcely had any roots of their own which they struck out. Here, on the hypothesis of the Potato being capable of being crossed even with plants not belonging to the bulbous genus, we may exclaim—What an extensive field is opened for the agriculturist! What singular and what useful experiments may we not make here? and that, too, were we not to reckon those experiments which might be made, and made with still greater certainty, in the extensive circle of bulbous plants.

"5. All the entire crop of Potatoes resulting from the four combinations above-mentioned, I have reserved for sets in future. Should the next planting remain free from every disease, as this year's planting was, I shall consider the problem solved, I shall acknowledge the American plant as a naturalised exotic.

"Mr. Rowlandson had long considered the Potato disease to arise from a deficiency of potash in the soil or manure in which the tubers were grown. He suggested the trial of sulphate of potash, to remedy this deficiency; this sulphate could be purchased in the market at £16 per ton, in the state known as the "pan sulphate," which contained about 80 per cent. of sulphate of potash, and 20 per cent. of sulphate of soda, and other salts; this was better than "granulated sulphate," which was impaired by an excess of common salt. This pan sulphate might be applied in drills, at the rate of 4 cwt. per acre. He had himself tried it with splendid effect. The state of carbonate in which the potash was found in land that had been burned, was much inferior to the sulphate of the same alkali. Nor did wood ashes from Canada and other countries contain more than 14½ per cent. of potash. The carbonate had a powerful effect in causing the rapid development of plants, but had no abiding and sustaining power afterwards; and they died away in consequence. The Brassic tribes took up much potash. In answer to an inquiry of Mr. Reynolds Solly, Mr. Rowlandson then favoured the Council with a detailed statement of the origin and progress of that expanding-concentric growth of fungi, occasioning what was termed "fairy rings."—Mr. Paine remarked, that on some fields of his in Surrey (where particular beds of the upper green sand formation, known to be rich in potash and the phosphates, crop out), his Potatoes grew with remarkable luxuriance in the first stages of their growth, but were subsequently attacked with the Potato disease to a greater extent than those grown on other fields not containing a similar amount of potash.—Professor Risler corroborated, from his own experience on the Continent, a confirmation of Mr. Rowlandson's views respecting the action of sulphate of potash. He remarked, that in the Vosgen sandstone, the decomposition of which formed in French Lorraine a rather great extent of very light soil poor in potash, a great quantity of wood-ashes was employed as a manure for Potatoes. These ashes were rich in potash, and their market-price high in proportion to the amount of soluble potash-salts they contained, but poor in the phosphates. The experience of many years on a great extent of land, had proved that the potato disease was diminished by the use of these ashes. The farmers of that district never employed farm-yard manure to their Potato-crops, because that application was invariably found to increase the disease: a result most probably occasioned by the circumstance of the farm yard manure being richer than wood-ashes in its amount of ammonia and the phosphates. Professor Risler added, that the principal object of Potato-culture in the Vosgen was the production of starch; and that the general opinion of the starch-manufacturers was, that the per-centage of starch in the Potato crop was increased by the use of the ashes in question. They found that diseased Potatoes gave in general one-third less starch than sound ones; this proportion, however, varying much, according to circumstances. Professor Risler concluded his remarks, by calling the attention of the

members to the analyses of Dr. Schleiden, Professor in the University of Jena, and to the opinions on the subject of the Potato disease expressed by him in his work on the Physiology of Plants and Animals, and the Theory of Plant-cultivation, forming the third volume of the new Agricultural Encyclopædia, published at Brunswick, in 1850. These opinions are contained in the chapter reviewing Dr. Schulze's work, entitled "Thaer or Liebig?"

"Mr. W. PATTERSON, of East Cross Causeway, Edinburgh, transmitted to the Council an elaborate paper on the Potato disease, including his own views on the subject, and chronological statements derived from various published sources, intended to elucidate the circumstances of its prevalence and progress.

"IMPOVERISHING EFFECTS OF COUCH-GRASS.—Mr. Miles, M.P., of Leigh Court, called the attention of the Council to the great importance of a knowledge of nutriment abstracted from the soil by weeds, especially by the *Triticum repens*, commonly known by the name of Couch or Twitch. In the last number of the Society's Journal, page 528, Mr. Hemming, the author of the elaborate paper on Agricultural Chemistry, had shown in his classification of tabulated results of analysis, how little was known at the present moment of the composition of weeds, and, consequently, how much still remained to be learned of the amount of their injurious effects. With regard to Twitch, in particular, which, he was sorry to say, was still fearfully prevalent in some parts of the country, he conceived it would be both an interesting and important inquiry to ascertain 'How much a good crop of it must consume the nutriment which should feed the crops of corn—say of Wheat, Barley, or Oats.' He quite agreed with Mr. Hemming in his remarks, that the present analyses rather give a general idea of the composition of weeds than are adapted to any purpose of immediate practical use; and that there is a large field open to the researches of chemists to determine what weeds are most injurious to the growing crop, as far as similarity of composition would show it, as also those that are most valuable for manure, from a like reason. Mr. Miles urged the attention of the Council to these investigations; especially to that connected with Twitch, which would, he thought, form an excellent subject for a lecture and discussion, or for a distinct communication to the Journal. The Council received these suggestions with their best acknowledgments, and ordered them to be referred for a report to Professor Way, the consulting chemist of the Society.

"OAK SOIL.—Mr. Adderley, M.P., of Hams Hall, Warwickshire, transmitted to the Council a communication on the subject of failure in the growth of Oak, in a portion of the old Forest of Arden, where the Oaks have retained, from centuries immemorial, their size and vigour. In a fine old Oak avenue in Mr. Adderley's Park, about 200 years old, two vacancies were filled up, about forty years ago, by young Oaks, which had grown well until the last two years, during which they had rapidly died away. Their roots were found rotten, and covered with a fungus like dry-rot; although the neighbouring Oaks were very large and fine, and an Elm filling a neighbouring vacancy in the same avenue was not infected, and its roots, close upon the rotten ones of the Oaks in question, were quite healthy. Mr. Adderley enclosed a sample of the top soil, twenty-two inches deep, and stated that the subsoil was red gravel to a considerable depth. The ground was dry, and did not require draining.—The Council thanked Mr. Adderley for this communication, and referred the specimen of soil to Professor Way.

"The Rev. R. J. STATHAM, of Tarporley Rectory, Cheshire, favoured the Council with a report on the success of his industrial training of the cottage boys in his central national school, in the habits and practice of manual husbandry in field and garden work, paying the boys according to the value of their work, and their superintendent about 2s. per day, with a commission upon the crops raised on the school land, subject to a strict Dr. and Cr. account: the earnings of the boys being deposited in the school saving club, as an inducement to saving habits, and bearing a high rate of interest.—Mr. Dalton, of Cardiff, transmitted a sample of Wheat from a crop sown in the last week of April, 1852, and yielding forty clean bushels per acre on good strong

loam after Turnips, from a sowing of two bushels per acre, the original stock having been obtained four years ago from Australia.—Mr. Learoyd, of Huddersfield, stated that he soaked his seed-corn about sixteen hours in strong old urine, allowing it to dry before sowing, with great advantage to the early growth and advancement of the plant (as well as to its removal of disease, for which purpose that application, with the addition of quick-lime, had so long been made to seed-corn).—Mr. J. M. Pasquier placed at the disposal of the members several samples of prepared seed-corn, with a request that they would test the merits or otherwise of the process adopted, which was intended to supersede or lessen the amount of other manuring matter to the crop.

"The Council having ordered their usual acknowledgments for the communications then made to them, adjourned to the 23rd of March."

THE BEARDS OF POLAND FOWL.

THOUGH the minds of some appear yet uninformed, I am gratified to learn that my remarks (July 31st) on the question whether Polands should or should not have beards, have been so effectual in removing the prejudice excited by the writer, whose dislike so unmercifully condemned the bearded variety. I showed that no argument whatever had been adduced to warrant such condemnation; and that it was simply an idiosyncrasy of taste—a mere matter of personal dislike.

Nothing, surely, can be more subversive of truthful inquiry than the conversion of a subject into an affair of like or dislike. Were such allowed, then would no property or attribute of poultry remain fixed or established: one might dislike the feathered legs of the Shanghae; another, the rose-comb of the Spangled Hamburg; a third, the *whole* cheek of the Spanish fowl being white, and so on. Especially, then, does it behove writers to be careful how they express themselves in print, for it is wonderful how people will at once adopt, as an axiom and a truth, anything that "they have seen in a book." If we do not like any particular properties of a fowl, yet have not proof that such are spurious, it is our duty to let nature alone, and the fowl also, and not keep it. I feel convinced that no one would have questioned the propriety of beards, had not a learned author, in his dislike, most irreverently attempted to uproot them.

To remove, however, the impression of dislike against the beard, I contended that, in the Spangled Poland it really harmonized with the whole appearance of the bird—with his magnificent top-knot, his remarkably voluminous and profusely-hackled neck, and with his whole dashing and *debonaire* deportment. The Poland is an exceptionable bird, differing in many of his most striking and characteristic and allowed attributes from other poultry; and I do affirm that there is a harmony, and a keeping, and a consistency, between the beard and the top-knot: that is, between the spreading and elongated feathers, or beard, below the bill, and the elongated feathers, or top-knot, above it. They, together, exhibit a conformity and a relation, which comprise an oneness, or complete whole. Diminish or take away either the one or the other, and the whole effect is gone—there remains a nakedness and a want; thus it ever is

"In Nature's chain, whatever link you strike,
Tenth, or ten-thousandth, breaks the chain alike."

For my own part, I would not admit the beardless Gold and Silver Spangled Polands at our exhibitions; not because I think them a spectacle of nakedness and want about the head, the neck, and the throat, but for the graver reason, that I deem them spurious, or mongrel, fowl—hybrid, I judge, between the Poland and Spangled Hamburg. In elucidating this, unfortunately the plumage can assist us little in our argument or proof, for the Golden and Silver Spangled Hamburgs closely approximate to the Polands. There are, however, more important points than the mere marking or colour of the plumage—there are distinctions of shape, or configurations of the body—circumstances relative to that great peculiarity of Polands—the topknot, the comb, as well as to the beard, and also to the tail, that facilitate and satisfy enquiry.

First, as to shape: the body of the Poland is very round, tapering somewhat suddenly near the tail; the breast is remarkably round and protruberant, "more so," observes Mr. Bailey, "than in any other fowl except the Bantam;" the neck is a characteristic and striking feature; it is not only long, but is of extraordinary thickness and fulness, and most profusely covered with voluminous hackle feathers; whilst in carriage it is upright, bold, and dashing. In the beardless variety there is a most perceptible modification and contrast, in a word, a very near approach to the Spangled Hamburg. The characteristic prominence and roundness of the breast is lessened, the body being narrowed, lengthened, and gradually tapering to the tail, the feathers of which, as observable in the hen, are, like those of the Hamburg, very much longer than in the true or bearded Poland. The neck presents a striking difference; all that general volume of the neck is gone, and it is thin, spare of feathers, and meagre; in size and proportion it is wanting.

Though, as I have said, the marking of the plumage affords us no help in tracing the Beardless Poland to its connection with the Spangled Hamburg, they being very similarly spangled, yet the nature, fabric, or material of the feathers differ, and affords assistance in defining the difference between the true Bearded Poland and the hybrid one. Thus, let any one handle a true Golden Poland here, and he will be struck with the remarkably soft, silky, yielding quantity of feathers, it is so peculiar, that at this moment I can recall the surprise on my first handling one; while the feel or sensation communicated by the beardless fowls is like the Hamburg, a comparative closeness and hardness of feather, there being nearly as great a difference in this respect as there is between the feel of a Shanghae and a Malay; such difference in the character of feathers in various fowls is well noticed by Mr. Bailey, and a very distinctive character it is.

Again, the top-knot in a great majority of beardless Polands (especially in the Golden) is insignificant. It is, I believe, invariably so in imported birds; but within the last year or two there have been raised, in this kingdom, some Silver beardless Polands with topknots of fair size. The golden, however, so far as I have seen at exhibitions, or heard of, still remain in *statu quo*, waiting some lucky hit or cross with the bearded to give them topknots, and to reduce their abundant, plated, pointed combs.

It is important to notice that, in breeding beardless Polands the greatest uncertainty prevails as to the quality of the chickens. In some chickens which I last year raised from the very best specimens of beardless Silver Polands, there was a very near approach to the rose-comb of the Spangled Hamburgs; an uneven, serrated, protuberant, and large plate of flesh terminating in a point with a mere tuft of feathers for a topknot, whilst a very few had topknots equal in size to the parents. *It is, indeed, a fact, as important as it is striking, that while the chickens of the true bearded Poland have invariably large and full-sized topknots, the produce, on the contrary, of the beardless Polands evince all the uncertainty and anomaly above stated.*

How is this? Why, I ask, should one be all certainty, the other uncertainty? The answer is clear, plain, and convincing enough; the beardless Polands being spurious, hybrid, now the Polish, now the Hamburg blood or type prevails, so that in the one instance we have topknot, in the other scarcely any, but with development of comb. *For it is a fact well known to breeders, that all cross-bred birds exhibit such constant tendency to lean to one parental origin or the other; as they term it, "they cry back."*

Thus have I shown that the beardless Poland is degenerate in shape, specially and generally, also in carriage, bearing, or deportment, and in its feathers; whilst the quality or character of its produce, or chickens, are ever varying and uncertain.

But what, on the other hand, has been urged against beards? Simple dislike. A whisper has, indeed, gone forth, which no one, however, will own to, that the beard is from a cross with the Russian fowl! In sober truth, the Poland has no one character of the Russian: not even in the so-called beard is there any resemblance. For, whilst the beard of the Russian is a long tuft, looking like a hanging bag of feathers, the beard of the Poland consists of imbricated feathers, scarcely longer than the rest on the throat,

and closely, compactly, and definitively arranged in a triangular shape, the base (extending in a line with the bill to the ears) being uppermost; it has nothing in common with the bearded tuft of the Russian, or of any other fowl. It is truly *sui generis*—true in its own kind—and an inborn, inbred characteristic of a true Poland.

In conclusion, I beg to say, that although I now write as a partizan of the bearded Poland (and coincide with the opinions of such experienced gentlemen as Mr. Vivian, as well as of Mr. Baker, of London, and others), it was only after mature reflection, observation, and experience on both varieties, kept at the same time, and in equal numbers, that the conviction was forced upon me, that the bearded are the true Polands, and that the beardless are spurious.—
F. R. HORNER.

THE SPONTANEOUS GROWTH OF PLANTS.

WE are now arrived at a period of the year when all the organic works of God, in our happy country, begin to either revive from their winter torpor, or to move with increasing vigour. It is now that every sunny morning draws us forth into the garden. Borders are explored in all directions; old pots of neglected plants hopefully examined, and a reviving taste felt in even the parlour of the citizen for floral beauties. Hawkers of flowers and shrubs are now becoming active; every scrap of a garden is receiving the general attention which spring alone witnesses. In such examinations, after the severe weather we have had, many a favourite shrub will have perished, many a border of tender plants, whose self-sown seeds from year to year seem to bloom for their own especial satisfaction, will be absent; but as the old alchemists used to say, "nature seems to abhor a vacuum," and so other plants will be found in their place: some appearing in various single varieties, others in masses crowding out of the soil, as if their seeds had been sown by handfuls.

The philosophers of the olden time noticed these things, and they reasoned upon the phenomena;—as they were usually wont to do they employed much verbiage, but held facts as of less importance. The result of this mode of attempting to arrive at truth was, that they concluded that the appearance of these plants whose seeds they had not sown, arose from "spontaneous generation." Yes, that was the phrase. It is idle to seek in their works for the meaning of the term "spontaneous generation," since it is evident they did not understand it themselves. It will be a more useful course if we examine the labours of the modern chemical philosopher, and the experiments which he has instituted to explain the cause of phenomena so familiar to us all. Indeed, as I have in another place had occasion to remark, the doctrine of spontaneous generation, as Dr. John Walker well observed in a letter to Lord Kames (*Memoir*, vol. ii., app., p. 56), is a doctrine that can only subsist where human knowledge and human understanding are but in a glimmering state. In such a state, philosophers saw mites generated from rotten cheese, and myriads of flies and creeping things arise from a dunghill or putrid marsh. Ignorant of the natural history and generation of these animals, they concluded them to be mere spontaneous productions, and the effects not of generation but of corruption! To add to their folly, the degrading doctrine never was extended to a lion or a horse, but confined to the poor insects, merely because they were creatures of whose nature they were ignorant. They knew not that the same power and wisdom were necessary to form a maggot that are requisite to produce an elephant. They formed the same conclusion concerning many vegetables whose seed escaped their eyes, such as the ferns, mushrooms, and mosses. Because they did not see the seeds of such vegetables, they readily concluded that they had none; and while the oak and the laurel were dignified with generative qualities, these plants were classed as the progeny of putridity. Equivocal generation thus readily became the asylum of their ignorance.

It is true that many phenomena of vegetable life, in cases like these, startle and confound us. The many lands of the Essex side of the valley of the Thames, if ploughed only an inch or two deeper than usual, abound immediately

with the wild mustard plant. Even the soil thrown out during the excavation of deep wells produces these. Other instances are well known, where bones, gypsum, &c., being spread, produce the abounding growth of white clover. The site of a fire is speedily tenanted, in the same way, by totally different plants from those growing around the spot. Liebig alludes to other instances of a similar kind (*Organic Chemistry*, p. 152). After the great fire of London, it seems large quantities of the *Erysimum latifolium* were observed growing on the spots where a fire had taken place. On a similar occasion, the *Blitum capitatum* presented itself at Copenhagen; the *Senecio viscosus* in Nassau; and the *Spartium scoparium* in Languedoc. After the burning of the North American pine-forests, poplars grew on the same soil—facts just as incomprehensible to the bye-stander as fairy-rings are to even the modern husbandman.

Let us, then, before we examine the cause of these appearances of peculiar plants, banish from our minds all dreams about their spontaneous generation. Let us rest assured that the seeds of the plants produced by creative wisdom have numberless ways assigned to them for their dispersion and the lengthened preservation of their vitality, which, although we can, perhaps, but partially discern, are fully sufficient to render unnecessary any evidence that He who made them has amply provided for their dissemination and preservation in the soil. What we do see assures us of these things, even in the commonest plants around us. For instance, as Professor Walker remarked, the ash and the plane have heavy seeds, but they are supplied with wings. A gale of wind can carry them from their original lofty situation to a considerable distance, and they remain on the tree till that gale arrives. The seeds of the more humble plants, that they may rise and be dispersed, spread their sail to the wind. The thistle spreads his beard, and away he travels to fix his residence in remote parts. The seeds of plants, once removed to a distance by the winds to their appropriate soils, rapidly vegetate. In some other cases they are carried by insects, or by other causes, deep into the soil, where they preserve their vitality for a lengthened period. The modern farmer will remember the variety of mummy wheat recently raised from some seeds found in an ancient Egyptian tomb, as a well-known instance of the vital tenacity in the seeds of plants. We need not, therefore, trouble ourselves with needless doubts as to the dissemination and preservation of seeds.

Once conveyed to the soil, those seeds are certain to vegetate with the greatest rapidity whose inorganic ingredients the soil most abounds in, and are copiously furnished to the plant in, the products of the fires to which we have alluded. The phosphate of lime, for instance, and the alkalies produced by the combustion of wood-fire, have thus their sites speedily occupied by white clover, and other grasses, in which these salts abound. The very same result is obtained by the application of the same salts, procured by other sources, to the soil. Liebig has noted some of these things. "It is not mere accident," he remarks (*Organic Chem.*, 151), "that only trees of the fir tribe grow on the sandstone and limestone of the Carpathian Mountains and the Jura; whilst we find on soils of mica, slate, and granite, in Bavaria, &c., the finest forests of other trees which cannot be produced on the sandy or calcareous soils upon which pines thrive. It is explained by the fact, that those trees whose leaves are renewed annually require for their leaves six or ten times more alkalies than the fir-tree or pine; and hence, when they are placed in soils in which alkalies are contained in very small quantities, they do not attain maturity. When we see such trees growing on a sandy or calcareous soil—the Red Beech, the Service-tree, and the Wild Cherry, for example, thriving luxuriantly on limestone—we may be assured that alkalies are present in the soil, for they are necessary for their existence. Can we, then, regard it as remarkable that such trees should thrive in America, on those spots on which forests of pine, which have grown and collected alkalies for centuries, have been burnt, and to which lands the alkalies are thus at once restored? or that plants remarkable for the quantity of alkalies contained in their ashes should grow with the greatest luxuriance on the localities of conflagrations? It is thus that wheat will not grow on a soil which has produced wormwood (a plant remarkably abounding in potash, the 'salt of wormwood' of

the old chemists); and that wormwood does not thrive where wheat has grown, because they are mutually prejudicial, by appropriating the alkalies of the soil.

It has been sometimes noticed by the farmer, that the same luxuriant growth of certain plants is produced on the site of fires in a field, although the ashes produced are carefully removed. This arises, amongst other reasons (even supposing that none of the soluble or insoluble portion of the ashes is allowed to mix with the soil), by the charring effect of the fire upon the organic matters of the soil on which it rested; for all soils contain more or less of these animal and vegetable substances, and their partial combustion produces the same ingredient, such as charcoal, salts of lime, alkalies, &c., as the weeds or other plants burnt on the surface of the land. The amount of organic matter contained in soils is, in fact, much more considerable than is generally understood. Davy found four per cent. in the soil from Sheffield Place, in Sussex, and five per cent. in the finely-divided matters of a turnip-soil from Holkham (*Lec.*, p. 175). And how deeply these animal and vegetable matters are dispersed, is shown by the fact that they are found in even the clays obtained from pits by the makers of pottery ware. It is upon similar chemical principles that Professor Way has recently given an explanation of the origin of fairy-rings, which are caused by the growth and gradual spreading from a centre of certain agarics or toadstools. The ashes of these, and of the grasses which formed the fairy-ring, being examined, were found to contain per cent (*Jour.*, *R. A. S.*, vol. vii., p. 553)—

	Agarics.	Grasses.
Silica	1.09	16.10
Lime	1.35	10.47
Magnesia	2.20	2.49
Peroxide of iron	—	2.93
Phosphoric acid	29.42	6.54
Sulphuric acid	1.93	5.40
Carbonic acid	3.80	12.47
Potash	55.10	35.23
Soda	3.32	—
Common salt	0.41	5.79

"On the foregoing analysis," observes Mr. Way, "I think we may clearly explain the whole growth of the fairy-ring. A fungus is developed on a single spot of ground, sheds its seed, and dies. On the spot where it grew it leaves a valuable manuring of phosphoric acid and alkalies, some magnesia, and a little sulphate of lime. Another fungus might undoubtedly grow on the same spot again; but upon the death of the first, the ground becomes occupied by a vigorous growth of grass, rising like a phoenix on the ashes of its predecessor. An experiment was made of spreading some fungi on the grass of the pasture where the rings occur. The letters, in the form of which the fungi were arranged, were clearly visible a month afterwards. Such researches as these, although they may be correctly regarded as mere preliminary steps in our attainment of knowledge, are still advances in the right direction to the examination of the abounding phenomena which attend the farmer in every field and in every path. They all tend to lead him on to higher and holier ground—to elevations whence he can discern the arrangements and wisdom of God, as clearly and as gratefully in the white clover springing up by the road-side after, perhaps, a gypsy's fire, or in the dark green herbage of a fairy-ring, as in the luxuriant growth of the corn, whose seeds are sown by man and fertilized by his labours."—CUTHBERT W. JOHNSON.

NOTES ABOUT ANIMALS.

THE RAVEN.—A neighbour of mine, who is a farmer, and a bit of a naturalist, has had for some years past a pair of Ravens, which have regularly reared their young on a retired part of his estate. Many have been the attempts of bird-nesting-boys to secure them, but without success, as they are carefully preserved. A year or two since, a relative of the farmer's wishing to have a pair of the young ones, the nest was taken, and the young birds placed in a hamper, and sent with other articles in a cart twenty-six miles distant. On arriving at their destination they were put into a

hen-coop, which stood in a back yard on the premises. On the following morning, to the surprise of their new master, the old birds were in attendance and endeavouring to feed their young ones; they continued about the neighbourhood with this object for some days, but finding their efforts fruitless, they at length returned to their old haunts. This furnishes another example of the force of natural affection, guided by instinct.

CURIOUS HYBRIDS.—Some time ago, whilst attending an Agricultural Meeting, held at Wickham Market, my attention was called to three singular looking animals in a pen, which were a cross between the fallow deer and our common sheep. Their heads and legs were those of the deer, with fine smooth hair of a rufous, or light reddish-brown colour, and their tails, instead of being of wool, were of hair also. The man, in whose charge they were, said that the sheep and deer grazed together in the same park, and it was to this circumstance that their origin was owing. The animals in question partook much of the deer in their habits, they were wild and active, and much of the deer in their appearance, being light and elegant. They were, I think, about a year old; and what became of them afterwards I never heard.

TAME LIONS.—Whilst breakfasting one morning, at a boarding-house, in King-street, Cheapside, a gentleman who sat next me, remarked that one of his lions, which he had brought from the Cape of Good Hope, had escaped from confinement, and after wandering along a street or two, had entered a banking house, and quietly placed his head upon the counter, to the dismay and confusion of the clerks and officials; and it was in this office, on his being sent for, that he had found him. He accordingly fastened his pocket-handkerchief round the animal's neck, apologised for the alarm which his unexpected intrusion had occasioned, and led him back to his domicile. Observing some incredulity in my looks at this narration, the gentleman added, "If you please you shall walk with me, and see the lions." So after breakfast we proceeded together to the White Bear, in Basinghall-street, which was close by, and having ascended a flight of steps to an upper room, he unlocked the door, and asked me to follow him. I felt unable to sustain the part of Daniel in the lion's den, and hesitated. "They'll not hurt you," said he; and forthwith drew me inside and fastened the door. I stood in company with four full-grown lions, about fourteen months old, and the size of large Newfoundland dogs. Being a stranger, they quickly surrounded me, and began to exhibit all sorts of playful emotions; one of them attempted to place his fore-paws on my shoulders, another took my arm in his mouth, whilst a third smelt at me all round. "Dont be afraid," said the gentleman; "they are only wanting to have a game of fun with you." Thus reassured, I returned their caresses, and we soon became the best friends in the world. But lions play is no joke. They bounded about, and grappled with each other upon the floor. I maintained my standing position during the *meleè*, but my companion was upset, and found it very difficult to rise from the floor with two or three lions upon him at once. Their strength was prodigious, and their muscular energy, as shown in sport, told a fearful lesson of its effects when excited by revenge or prompted by hunger. They would seize a glove from the end of a stick when held up to the ceiling eight feet high. Their coats felt more like short wool than hair, and became unctious through exertion. We left, after amusing ourselves with them for about half an hour. The gentleman told me that he had brought them to this country on speculation, and that they had consumed twenty sheep during the voyage. What prices he obtained for them I never learnt; but one of the animals, I believe, found its way into some private collection, and the remaining three into our travelling menageries.—S. P., *Rushmere*.

HYBRID BETWEEN THE PHEASANT AND FOWL.

"A perpetuated cross between the pheasant and the fowl there never was, nor ever will be."

By the unfortunate omission of a single word, I have decidedly brought down the vengeance of "Scrutator's" pen

upon my negligent head. I saw my mistake instantly when I read the sentence in print, though I considered it would be understood, that a hybrid monstrosity does make its appearance, by rare chance, in the shape of a cross between the fowl and the pheasant, and I thought the sense of my subject, from what almost immediately followed, would sufficiently unfold and correct my omission, without troubling our Editor again upon the matter. I never could succeed in breeding a cross of this description; I never saw one. I went to London, note-book in hand, on purpose to see the Metropolitan Poultry Show, and found the meeting put off till the following week, and being obliged to return I missed it, and the hybrid "Scrutator" mentions into the bargain. I have heard tell before of the like nature, and from what I could learn, it was certainly no beauty.

"Scrutator" objects to my "talk" agreeably to nature's dictation; but I really do think he is wrong when he says the hen renders "*no assistance whatever!*" It is certainly usual for her to cast the shells from the nest, though I never remember having stated that she interfered mandibly at the parturition of the chick from the shell. I was conscious, some twenty years ago, of the "instrument at the end of the beak," and I always thought that the chick worked its deliverance from the shell, in the first instance, with this "instrument;" or, as "Scrutator" says, that it "cuts its way out."

The "nature's dictation" that I mean causes the hen to sit very close at that time, and from the warmth of her body the chick becomes strong, and is thereby enabled naturally to burst from its confinement. If it cannot do so of its own accord I would not give much for its chance, that is, for its ever growing up to become a first-rate fowl.

The attendant on "Mr. Cantelo's machine" keeps it to a proper temperature, turns the eggs, &c., following "nature's dictation" as near as may be; and so they did in Egypt centuries ago.

But in my work-a-day article I have drawn my inferences from my own practice.

As to Pheasants—where have I made use of the expression "on or about the 19th day?" If "Scrutator" will scrutinise my writing correctly, he will find it expressed thus, "at the expiration of *nineteen* days," &c. Now, surely, it is preferable to be on the *qui vive* at the 20th, rather than remain careless about the matter till the 23rd or 24th day. Also, begging "Scrutator's" pardon, I have had eggs hatch two days before their usual time, and that of no later date than last spring. With fresh eggs, and a good sitting hen, is it an unusual circumstance? At any rate, the 23rd or 24th day is not *early* for pheasant eggs to hatch under proper management.

I am much obliged to "Scrutator" for pointing out the sentence, which was certainly calculated to mislead. It will also caution correspondents to beware of the slip, both of the mind and the pen, and teach us to endeavour and express ourselves properly; for I have no doubt, if the truth were known, our Editor has a vast deal of bother about some of us on this account.—UPWARDS AND ONWARDS.

TO CORRESPONDENTS.

HORTICULTURAL AND POMOLOGICAL ASSOCIATION (A Nurseryman).—This association is not one which interferes with, but will promote your legitimate trade; and in the formation of the association no such idea as opposition was entertained. For several years a vast number of our correspondents have written to us, wishing us to procure florists' flowers, seeds, trees, and plants for them, and complaining that in their neighbourhood they either could not obtain the articles at all, or could not depend upon obtaining them of true and genuine quality. It is, therefore, to accommodate all such that the association has been formed; and so far from clashing with the interests of the trade, its chief end is to obtain from the *most respectable and pains-taking* of that body such articles as the members of the association may require, and in which the greatest confidence can be placed. All nurserymen and seedmen who have anything new or rare which they have to dispose of, will do well to forward their lists to the association, that it may be enabled to act as agent between them and purchasers, with whom they otherwise would not come in contact. There are some men who are so narrow-minded on these subjects, they look with jealousy on every attempt to propound or extend a principle with which they are not themselves personally interested. We even know some old-fashioned nurserymen who were foolish enough to make a stand against the establishment of the Horticultural Society, and who maintain that position to the present day; and we have heard others say that the nursery trade has never been what it was since that society was instituted.

INJURING PLANTS BY FUMIGATING (W. X. W.).—We are exceedingly sorry that your second smoking should have so injured your greenhouse plants; but we are not of your opinion that the disaster was owing to the plants having been watered between the two respective nights of fumigating, because we have often done so without experiencing such a result. We should be more inclined to suppose that the dose of smoke was too strong, or too hot, or that some extraneous matter was in the tobacco. If the last case is not the real one, we should think shade and syringing would bring the plants round. We like to smoke plants when their leaves are dry, because when wet many small flies are covered by the moisture, and thus escape.

GRAFTED ORANGE TREE LOOKING SICKLY (A Subscriber).—This is in a six-inch pot, and a foot high. If the soil is at all unhealthy, turn the ball out of the pot, pick away most of the earth without injuring any of the fresh roots, but cutting off any decayed ones. Put the plant in a similar or smaller pot, drain well, and then put it in sandy fibry loam and peat, with a little charcoal, and then place it for a month or two in your cucumber frame. If you have not got one, defer the process for a month, and then, after adopting the treatment we have recommended, keep the plant in a warm corner of the greenhouse.

PIGEONS (A. G. P.).—To introduce carriers, tumblers, and nuns into a dovecote occupied with common pigeons would be a measure of doubtful prudence. General hostility would be manifested against the new comers; and even were this overcome, and they were allowed to breed in peace, there would be great hazard at the intermixture of their progeny with the former tenants. Besides which, fancy pigeons would require a more generous diet than would pay for the dovecote birds, which incur so many risks in seeking their food abroad. Well-bred carriers are worth from £1 10s. to £2; tumblers from 10s. to £5; and nuns from 12s. to £1. To buy young birds is the safest plan, especially if they come from the neighbourhood; but old birds, if confined till they have young, seldom evidence any wish to leave their new abode. With carriers, as might be supposed, there would be the greatest difficulty. Any dealer can supply you.

EGG-EATING HEN (Amateur, Great Yarmouth).—The remedies you have had recourse to in the attempt to cure your hen of her egg-eating propensities are those most likely to have been successful, saving only the immersion in cold water; the probable effect of which would be rather to create disease than do away with a bad habit; nor can we advise the Scotch snuff. In fact, this habit is rarely overcome; and whatever the original cause, few, very few, instances of successful treatment are on record.—W.

COLOURED EVERLASTING FLOWERS (J. P. K. C.).—The everlasting flowers seen in the seed-shops in London are a species of *Gnaphalium*, most likely *G. marginatum*. They are dyed, but by what process or mode we cannot ascertain. It is a trade secret. They are dyed in France.

RANUNCULUS PLANTING (Wal).—You need not be alarmed; there is time enough to plant your Ranunculuses yet; and as warm weather has set in very pleasantly upon us, they will bloom quite as well as if they had been planted a fortnight ago. *Auricula* and *Fuchsia* seeds sown now will, if well managed, bloom next year. We cannot tell why your *Hyalanthus* have not bloomed well this year. If you could see Mr. Appleby's now in bloom at Uxbridge, you would say they were splendid—some of them have five perfect spikes from one bulb. Your's must have been either badly managed, or the bulbs have been exhausted ones.

HYACINTHS WITH MANY OFFSETS (F. H.).—Hyacinths in glasses are not more liable to produce offsets than those in pots, or in the open ground; the offsets are formed between the lower scales the season previously.

TURFING VINE-BORDERS (Ibid.).—These may be turfed over, but they are better without such covering, because they sometimes require mulching with leaves or littersy manure through the winter, which cannot be applied if the borders are turfed; besides, the turf impoverishes the border greatly, and, consequently, injures the Vines. If the Vines are not forced early, the borders may be turfed with impunity.

POINSETTIA PULCHERRIMA (A Young Beginner).—Your *Poinsettia pulcherrima* has three poor shoots, and as many leaves. You had better let it flower, and cut it down after it has bloomed; then keep it rather dry in the pot; replot it in May, and grow it slowly near the glass till the autumn; it will then bloom better. It is not a proper plant to place in your heated bed.

HEDYCHIUM GARDNERIANUM (Ibid.).—This will answer well to plant out. The old shoots that have flowered should be cut down annually. It requires a short season of rest in winter, which may be induced by withholding water. In the conservatory at Chiswick, there is a fine specimen planted out in the border which flowers strongly every year. This house is not a stove nor a greenhouse, but intermediate between the two.

SOWING PELARGONIUM SEED (W. H. O.).—The reason why *Pelargonium* seed should be sown in March is, because, if sown as soon as gathered, the plants would be so tender that they would perish in the winter. Follow up Mr. Appleby's directions, and your seedlings will be safe.

SUMMER DUCK (R. E.).—This is *Querquedula sponsa*, the American Summer-teal, which has bred, we believe, at the Zoological Gardens, and is said to be of very domestic habits.

ARRANGING COLOURS IN FLOWER-BEDS (E. S. F.).—Capital idea, and a practical refutation of the old saying, "That there is nothing new under the sun." Here is a set of flower-beds represented on a page of post paper by common wafers, such as they used for letters in olden times; each wafer is of the colour or tint of the flower of a certain bedding plant with which the bed, represented by that wafer, is intended to be planted. A few dozens of wafers, in five distinct colours, and in a dozen of shades, placed almost at random on the corner of the breakfast-table, would learn one more real sense about the value of just arrangements in flowers, than a book of the largest size full of descriptions. Shift the wafers about till you make a picture to your own mind; then fix them in their places, and plant accordingly. Two or three trials, or perhaps the first, will satisfy any one with his or her own work, and if so, the

rest of the world has nothing to do in the matter. Gardening has been extended, not curtailed, in our pages since we enlarged for Poultry Bees, and other departments. Surely one with such an excellent contrivance for arranging flowers, would not desire that other folks who like bees, fowls, and all sorts of rational and innocent pleasure, as well as flowers, should not be gratified.

PLANTING BEDS (Ibid.).—You should add some fresh soil to all your beds. On an average, all the plants you name should be inserted about six inches apart each way, and nine inches would do if you had annuals ready to put into the spare places.

BACK NUMBERS (Ibid.).—All the numbers you mention, or rather any of our back numbers, can be obtained at our office. Your bookseller is totally wrong in his information.

BED OF BRUGMANSIAS (L. M. N.).—Such beds as those described in THE COTTAGE GARDENER for June 13, 1850, may be made at any time, if you can hear of old plants of Brugmansias to be sold. The officers of the Horticultural and Pomological Association, if you belong to it, will probably find them for you.

CALECOLARIAS IN SHADES (S. S.).—Trefoil-shaped beds will do well for giving three tints of Calceolaria colour, as each kind can occupy a lobe, or division. Your large bed should be planted with a mixture of three kinds, as *Ageratum* for a centre bed; then a broad ring of *Scarlet Geranium*, edged with some low white plant. That way it would match the other large bed at little cost; but a better arrangement still would be, a centre of the *Salmon Geranium*, then two circles of *Compactum Geranium*, and two more with *Tom Thumb*. There are not kinds enough yet in the market to fill up complete shading; and lastly, if you could hit off a real shot-silk bed, it would be best of all for that part, but many good gardeners cannot do that. After all, the safest way will be to use your own *Commander-in-Chief* Geranium for a centre, with a broad belt of *Heliotrope* round it, with a row of *Collinsia bicolor* to fill up the outside till the *Heliotrope* spreads. This *Collinsia* should be sown round the bed about the 10th of April.

BEGONIA SEEDS (W. H.).—You misunderstood the import of the passage. It is not necessary to have the seed-pot in the dark, only the soil in it where the seeds are in; but when you cover a pot or a dozen of them with an old "Times," the pots must necessarily be darkened or shaded by the paper. It was in addition to this common plan that pieces of glass are to be laid across seed-pots of most stove seeds that are very small, in order to keep the air about them as uniform as possible, and damp enough to stimulate vegetation.

STRIKING GLOXINIA LEAVES (Ibid.).—The Dahlia leaf might grow from the footstalk like the Gloxinia leaf, but if it does no one knows it. Try, and be the first to make the discovery yourself, and let us hear all about it.

GARDEN PLAN (A Beginner).—We never write private letters to public correspondents; if we did, we must keep a private secretary, and about twelve or fifteen clerks, with a few assistants occasionally, when the clerks were overworked. We are much struck with the beauty of your terrace, the flower-garden, and, indeed, with all the arrangement about the house and grounds; but we might just lead you wrong, as soon as not, by attempting to plant your beds and grounds unless we were on the spot. We would plant none but standards of hybrid perpetual Roses along the terraces, and on the flower-garden side we would have them in pairs of one sort. As 2 *Madame Lafay*, 2 *Duchess of Sutherland*, 2 *Baron Prevost*, 2, 4, or 6 of *Genet des Batailles*, 2 *Dr. Marks*, 2 *Standard of Marengo*, 2, of *Austerlitz*; and at the top of the steps, the last 2, we would have in half standards of *Mrs. Elliot Standard*. The large circle in the middle plant with the 3 blue *Lupines*. Without a good stock of plants, you must be content this year with annuals of all kinds, and sow in April, May, and June, as we often advised, and then transplant.

STAUNTONIA LATIFOLIA (Mrs. B.).—All our readers ought to know that we must not publicly state where plants, &c., are to be had; but, without doing injustice to any one, we may say that we took two plants of *Stauntonia* in a collection of 300 plants, which averaged one shilling each, and we think this fine evergreen climber might be sold, in single plants, under 2s. 6d. each, if there was a good demand for it, and that we think we can vouch for till everybody has it. But recollect the flowers are good for nothing. Read Mr. Beaton's account of it again.

HINTS AND QUESTIONS (H. C.).—1. *Scarlet Geraniums*—*Tom Thumbs*. "These I keep in the winter with less trouble than I observe some of your correspondents take. I take them out of the ground, thoroughly shake off the soil, hang them up by the heels in a cellar, by the dozen, and they are alive and well for the spring. (Two conditions are absolutely requisite for the success of this plan—perfect dryness and exemption from frost.) Are there any other plants that will bear this unceremonious treatment? (Not that we know of.) 2. *Hyacinths*, *Pot Tulips*, and *Narcissus*. Carbonate of ammonia, dissolved in the water, about a dram to the gallon, always improves them. May this manure be used indiscriminately for other window plants? (No doubt of it.) *Verbenas*. Is there any mode of keeping these over the winter? If I leave them out-of-doors, they do not live. If I take them into the house, they die. (They must be raised from cuttings annually; old plants taken up almost always die with every one. A few plants kept in pots all the summer, to get cuttings from in the spring, is the easiest way.) Must they die, and be annually placed? (Certainly.) *Poinsettia pulcherrima*. I cut mine down in December, when the leaves were falling. Should it not have been spared, to give the beautiful bracts a chance of appearing? When may we despair of them? Are the older or the younger plants the likeliest to throw them out? (You cut it four months too soon; the place was too cold for it, else it would not cast the leaves in December without flowering. April is the best time to cut it; and old plants will do better with young beginners, and young plants will be best with old gardeners.) *Myrtles*. I have two that will not flower—what would improve them? They lack no attention, and are of the flowering species. (We cannot say, as you did not state whether they were growing most luxuriant, or looking anything but comfortable.) Is anything known of a Cape plant called *Scholus*? I have plants of it, from seeds, and can get no flowers either in stove or greenhouse. (Your Cape plant is

Schotia speciosa; a strong shrub, with bright red pea-flowers; it comes in all collections of Cape seeds, and often takes four or five years to flower it; but once at a flowering age it goes on every year to flower, and it is a hardy greenhouse plant, and dislikes the stove very much.) *Arbutus*. All my shrubs flower, but will not mature the fruit. How is that? (The trees are yet too young, or the climate too severe.) *Lauristinuses* bud, but are nipped in the first frost. Should this be?" (No, not in Britain.)

THE POULTRY-BOOK (Cochin).—It has been delayed solely on account of the coloured plates; its publication will positively begin this month. We shall probably republish the "Feathers" in it. Sometimes, but not usually, Spanish fowls lay as many eggs as Shanghaes do; neither are they such good layers in the winter, but their eggs are much larger.

SUDDEN DEATH OF SHANGHAES (G. W. D.).—If fed high they are liable to death by apoplexy. Mr. Tegetmeier has shown this in our pages, by reporting that he found a ruptured blood-vessel of the brain in cases of the sudden death of these fowls.

SHANGHAE EGGS (J. Y.).—We cannot give you the information you seek, but we know where a few from selected Sturgeon and Moody birds may be had for 20s. per dozen, including package.

LUCIA ROSEA GERANIUM (T. B.).—The leaves are very much mildewed. It has been kept probably in air too cold and too damp.

HYBRID BETWEEN THE PHEASANT AND FOWL.—Mr. J. Patterson, of Thame Park Gardens, says:—"I confidently assert that I have seen five mules resulting from a cross between the cock pheasant and the common domestic fowl, which were reared by my father, gardener at Ballumbie, Forfarshire, N.B., and I dare say many living witnesses can be found in that neighbourhood who can testify to these facts. In appearance they neither resembled the domestic fowl nor the pheasant, and their call was likewise different, it sounded something like Pea, pea, poup. I may likewise state that the pheasants had common hens as foster parents, and from them we got the mules, and there was not a common or domestic cock within half-a-mile of the hens."

DISEASED FISH (A Lady Constant Subscriber).—Fish in a pond like yours, where the water is seldom changed, will bring disease to the fish its inhabitants. The slime upon them is a parasite to which they are especially liable in such a situation; we know of no remedy but a frequent change of water.

ORCHARDING (A. C.).—We have received a communication from a correspondent signing himself *A. C.*, *Chelmsford*, remonstrating with us on the statements we made in our papers on orcharding, respecting the prices of Apples in 1850, and our general remarks as to the profitability of orchards as a branch of rural economy. He says—"In 1850, you state the price at Covent Garden was 5s. 6d., and in that year I was a grower, but I find, on reference to my books, that I did not realise an average price of 2s., for which the expense of gathering should also be deducted." Now, it is impossible for us to say what price growers have returned to them by their salesmen, and what drawbacks there may be on the sales. All our *data*, as regards remuneration, are taken from the statements of the growers themselves, and the averages we quoted are from the published returns of each year, which show the weekly prices realised in the markets. From these returns we find that the average from August, 1850, to August, 1851, was 5s. 6d.; but, taking kitchen and dessert Apples together, it was 6s. 4½d. In the evidence taken before the committee of the House of Commons, we find a grower stating that the average price of 4s. in the London markets, including the cost of production, would remunerate him. If, then, 4s. be a remunerating price, and the average price in the market is 5s. 6d., it is clear the grower is realising a profit even in the face of an importation of 467,629 bushels of foreign fruit. We cannot, of course, account for the low average of 2s. which our correspondent had returned to him; but, for his satisfaction, we can state, that from the beginning of August to the beginning of November, in that year, the prices were from 1s. 6d. to 8s.; from November to January, 3s. 6d. to 8s.; and from January to May, 5s. to 10s. It may be that he pushed his produce to a bad market when the supplies were great, and the prices in consequence low; but these are matters we cannot speculate upon. All we can do is to deal with facts, and upon such facts we base our arguments. But, apart from such facts and figures, we have other evidence that the orchardists have been agreeably disappointed by the removal of the duty; for we know one who was a witness before the committee, and who declared he had already displaced eight or ten acres in anticipation of the removal, but has within these seven or eight years replanted between 2000 and 3000 trees. The prices which are quoted weekly are those at which dealers are supplied, and have nothing to do with consumers.—H.

POMOLOGICAL AND HORTICULTURAL ASSOCIATION (W. H. O.).—This association will obtain florists' flowers, or anything else connected with gardening that you may require.

CAPT. HORNBY'S SPANISH FOWLS.—"Mr. Timothy Mason writes to me, to complain of my letter in THE COTTAGE GARDENER, which he says is likely to damage his character for truth in the poultry world, and to injure him. He rests his vindication for the statement, 'that Mr. Poole was the breeder of Captain Hornby's best birds,' on two points, on both of which, however, he has been misled. 1st. That I possess a cock bred by Mr. Poole, which has won for me all my prizes; which took the first prize at the Metropolitan, and is the father of my best chickens. 2ndly. That I possess a hen which I bought from Mr. Gilbert, 'as an imported hen,' but which (he says) was bred by Mr. Poole. As regards the cock, my reply is, that I never showed him, except once (at Birmingham). That I never bred from him. That he was not at the Metropolitan, and that the bird died after Birmingham. For the truth of this I pledge my word. As regards the hen—I bought her from Mr. Gilbert as 'an imported hen;' and that gentleman, in a letter this morning, assures me that such is the case, and that she was not bred by Mr. Poole. I should be very sorry to injure Mr. Mason, who has been misled; but I really believe not wilfully so. He seems to have mistaken the cock I showed at the Metropolitan for Mr. Poole's, and to have mixed up my hen with some other, which Mr. Gilbert may have purchased from Mr. Poole, the excellence of whose Spanish fowls I readily acknowledge. My statement was, 'that I have not in my

yard one of Mr. Poole's breed,' which I believe to be strictly true. I could not allow an assertion, 'that Mr. Poole was the breeder of my best birds,' to remain uncontradicted; but in justice to Timothy Mason, I wish to state my impression, that he has not wilfully been mistaken.—WINDHAM HORNBY."

VARIOUS QUERIES (C. W. F.).—Apply to Messrs. Rendle, Union-road Nursery, Plymouth; *Hamilton's Treatise*, too, from Mr. Hamilton, by post; address to him at Bank Hall, near Stockport. "Is there any other work on heating houses, pits, &c.?" McIntosh's "Book on the Garden" enters largely into the subject; there are some others, but such has been the frequency of the changes in these things that it is well to consult later publications. We are ignorant as to how "the trade" stands with regard to the Cayenne Pine; we have seen none advertised. It is not yet to be affirmed that the Hamiltonian system "answers only for the Black Jamaica;" this kind has been well-proved, and some of the best Queens—so says Hamilton. The Jamaica is a Pine possessing peculiar habits; what other kinds may be brought to suit is not thoroughly concluded.

CAMELLIA-FLOWERING AND BALSAMS (Subscriber, Reading).—See an article last week. To have the individual flowers fine, the flower-buds will require thinning, in addition to the treatment necessary to keep the plants stubby and healthy.

ALPINIA NUTANS NOT FLOWERING (A Young Gardener).—This should have plenty of room either in a tub or border; be grown in rich soil, in which loam forms a constituent part; and have, during the first periods of its growth, a high temperature, not below 70°, and from 80° to 90° with sun, and an atmosphere at saturation point, with full exposure to light, and more air as the stems approach maturity. Where room and other essentials can be given this plant is well worth the necessary labour.

DRESSING VINES (Ibid).—By taking bark off Vines, and dressing their stems with a mixture of soft-soap, sulphur, and tobacco-water, you have done right. The loose bark of Vines is better removed, but the firm and inner bark should not be touched. The loose matter only harbours insects. We think your mixture will answer, provided you put it on cold, and you did not have too much soft-soap. The boiling of such mixtures often greatly increases their strength: witness the mode of boiling sulphur and lime together, as detailed last year in these pages. We are a little shy of using many mixtures, from having seen, ten years ago, a range of houses, Vines and Peaches, almost entirely destroyed; and, from the gardener's account, there was little difference in the mixture from yours, with the exception of having nux vomica and black sulphur. We never saw such a sight before, though we have been used to dressings for many years. We have, however, long preferred simple matters, sulphur and clay. The thickness of paint, or even clay itself, is just as good as any other,—the object being to imprison all eggs of insects, and thus destroy their vitality.

VINES STILL UNPRUNED (Emma).—Prune without delay. If you have given greenhouse treatment they will not yet be started. If pruned to a spur before, do the same again; if on no particular system, have plenty of young shoots, with the most prominent buds for a crop, and during summer arrange for a future systematic course. You will find previous instructions to suit you, but, as you are your own man, if you give us another list of queries we shall give all minutiae.

LEMON TREES (Ibid).—You say the leaves are shrivelled and drooping, and the roots in rotten tubs. Get fresh tubs, or pots, and after removing a portion of the old soil, and securing good drainage, pack the roots firmly in fibry sandy loam. If you could give them a little dung heap they would thank you for it; if not, keep the plants in the warmest part of the greenhouse; use tepid water, with a sponge or syringe over the stems frequently; and do not water much at the roots until you see fresh growth taking place. Then you may cover the surface of the soil with a mulching of rotten dung.

CACTUS SHOWING BLOOM (Ibid).—Syringe the stems frequently first, before you saturate the roots. You will hardly have enough of heat yet to open the flowers nicely, and, therefore, it would be advisable not to soak the soil until the middle of April, at least. Do not let it, however, be dust dry.

STRIKING ROOTS OF SWEET PEA (Ibid).—You say you have done this under a hand-light, on the dunghill. Glad you have succeeded—a vast store of pleasure is before you. We suspect, however, that your Pea was a perennial, or everlasting one. No greater error exists than the imagining that nothing can be done by very simplicities.

HEN LAYING SOFT EGGS (Chicken-hearted).—As she is well supplied with calcareous matter, it is probable that she is too fat, and is suffering from an inflamed state of the egg-passage. Feed her less, give her green food, and one grain of calomel formed into a pill, with one-twelfth of a grain of tartar emetic; repeat this dose at the end of the second day.

RABBITS (T. K. A.).—We shall be glad to have some communications relative to their management, and hoped before now to have arranged with some competent person to detail the results of his own experience. Can any of our readers say where *setting-boards* for setting Moths and Butterflies can be purchased? Why not make them of flat pieces of cork, which you can buy of any carrier?

COVERS FOR THE COTTAGE GARDENER (P. P.—, Penge).—You may obtain covers for any of the back volumes by applying to our office; or you may send the numbers there to be bound. *Pitmaston* is in Worcestershire.

DRAINING (K.).—It is quite impossible to state the charge for draining four or five acres of land, so much depends upon soil, situation, depth of drains, &c.

WEEKLY CALENDAR.

M D	W D	MARCH 24—30, 1853.	WEATHER NEAR LONDON IN 1852.				Sun Rises.	Sun Sets.	Moon R. & S.	Moon's Age.	Clock bf. Sun.	Day of Year.
			Barometer.	Thermo.	Wind.	Rain in In.						
24	TH	Afzelian; thick woods.	29.887—29.801	48—31	E.	—	55 a. 5	17 a. 6	6 4	15	6 23	83
25	F	LADY DAY. GOOD FRIDAY.	30.094—29.941	44—31	N.E.	—	53	19	rises.	☺	6 5	84
26	S	Marbled single dot; furze.	29.867—29.766	47—27	W.E.	—	51	21	8 a 11	17	5 40	85
27	SUN	EASTER SUNDAY.	29.663—29.616	56—25	W.	—	49	23	9 38	18	5 28	86
28	M	EASTER MONDAY.	29.632—29.615	63—27	N.E.	—	46	24	11 5	19	5 9	87
29	TU	EASTER TUESDAY.	29.533—29.271	66—28	E.	16	44	26	morn.	20	4 50	88
30	W	March Dagger; trees.	29.378—29.200	64—25	S.W.	02	42	27	0 29	21	4 32	89

METEOROLOGY OF THE WEEK.—At Chiswick, from observations during the last twenty-six years, the average highest and lowest temperatures of these days are 52.5°, and 33.8° respectively. The greatest heat, 75°, occurred on the 27th in 1830; and the lowest cold, 14°, on the 25th in 1850. During the period 117 days were fine, and on 65 rain fell.

BRITISH WILD FLOWERS.

(Continued from page 433.)

POPPYWORTS.—PAPAVERACEÆ.

CHELIDONIUM.—CELANDINE.

GENERIC CHARACTER.—*Calyx* below the germ, of two roundish egg-shaped, concave, acute, deciduous leaves. *Petals* four, equal, roundish, flat, spreading, narrowest at the base. *Stamens* numerous, about thirty, filaments widening upwards, shorter than the corolla. *Anthers* vertical, erect, compressed, blunt, of two lobes. *Germen* cylindrical, the length of the stamens. *Style* none. *Stigma* small, blunt, cloven. *Pod* somewhat cylindrical, of one-cell, and two-undulated, deciduous valves. *Seeds* numerous, nearly oval, dotted, polished, with a pale, compressed, notched *crest* along the upper edge; disposed in two rows, on short stalks, along a linear, permanent, marginal *receptacle*, at each side, between the edges of the valves.

CHELIDONIUM MAJUS: Common or Great Celandine; Swallow-wort; Tetter-wort.



Description.—It is a perennial. *Root* spindle shaped. *Stem* two feet high, branched, swelled at the joints, leafy, round, slightly hairy. *Radical-leaves* in a tuft; *stem-leaves* alternate, one to each branch. All the *leaves* smooth, very deeply wing-cleft, rather than pinnate; their lobes two or

three pair, with a larger terminal one, all rounded, bluntly lobed and notched; the lateral ones sometimes widened at their lower margin, near the base, almost as if eared; their colour a deep shining green. *Flowers* bright yellow, in umbels on long, often hairy, stalks. *Petals* oval, and smooth-edged. *Calyx* tawny, often hairy, deciduous. *Seeds* black and shining, each with a whitish deciduous crest.

Time of flowering.—April to July.

Places where found.—Beneath hedges, and in thickets, especially on chalky soils, and, as Gerard says—"in the shade, rather than in the sun."

History.—The *Chelidoniums* belong to the Polyandria Monogynia Class and Order of the Linnæan system. The name, Celandine, is derived from the Greek *kelidon*, a swallow, "not, says Gerard, because it first springeth at the coming in of the swallows, or dieth when they go away, for it may be found all the year, but because some hold opinion that with this herb the dams restore sight to their young ones when their eyes be out; which things are vain and false." We think it not improbable that the name was applied from its first *blooming* about the time of the swallows return.

The juice of every part of this plant is yellow, and very acrimonious. It removes tetter and ringworms. Diluted with milk it consumes white opake spots upon the eyes. It destroys warts, and cures the psora (itch). There is no doubt that a medicine of such activity may be converted to more important purposes. Salisbury assures us that it is an excellent remedy in jaundice, and other obstructions of the viscera; and, if taken with perseverance, will greatly relieve the survy. It should be used fresh, as it loses part of its virtue in drying.—In Cochin-China the roots are esteemed for various medicinal purposes. A double-flowered variety is sometimes admitted into gardens.

It gives a yellow dye to cotton, and is applied beneficially to ulcers in horses. The benefits derived from its juice are partly attributable to its acrid principle, and partly to the sulphur which it contains.

CHELIDONIUM LACINIATUM: Jagged Celandine.

This differs from the preceding in having its *leaves* cut into narrow, jagged, acute lobes, and in having its *petals* saw-edged or cut. Johnson gave a drawing and description of it in his edition of Gerard's Herbal, as long ago as 1636, but it had been previously noticed by Clusius and Bauhine. Professor John Martyn found it at Wimbledon, and Miller had previously found it there, and ascertained that it reproduced itself from seeds. (*Smith. Martyn. Withering. Gerard.*)

WE come now to that most important consideration—the general decoration of the grounds by trees and shrubs, creating that diversity of appearance which is at once destructive of baldness and productive of variety: without the latter it is vain to think of producing a lasting effect.

We confess, at the outset, that it is not easy to lay down rules for the disposition of trees and shrubs, whether for ornament or for mere shelter;—such rules might speedily lead to mannerism, which should at all times be avoided. Certain principles, however, may

be offered, by which to guide the uninformed; but even these must subserve—not overrule—the general impression sought to be created, and be modified less or more by local circumstances.

Planting, for the present purpose, may be classed under five heads; and as our remarks are not intended to refer so much to the park as the pleasure ground, we shall dwell chiefly on Shrubberies, Shrub-masses, Shelter, Seclusion, and Boundaries: these are the chief subjects, but they may compel us, in our course, to diverge occasionally.

One of the first principles to carry out in a new place is Privacy or Seclusion; without this being secured, in a tolerable degree, the highest embellishments cannot long prove satisfactory. Public promenades are another thing; there people go to see, and to be seen, for a short period. Of course, with the suburban villa privacy is doubly important. As to country seats, their extent, and isolated character, by liberal planting, will almost, without extra pains, have this point secured to them. In laying out suburban grounds, therefore, the designer takes special care to examine well his boundary, in order to ascertain the bearing of unpleasant objects, and the direction of objects of interest which may be "brought in," or appropriated, as our landscape men have termed it. If, for temporary purposes of shelter, &c., the latter portions must be planted out, it should be with such ordinary or unimportant trees or shrubs as may, in a few years, be reduced in height, or cut clear away without regret. Our modern villas are, in the main, judiciously placed on elevations; and this is a happy circumstance for the planter, as he can occasionally call in views or vistas without causing leanness or exposure in the boundary—the planting, in such cases, being composed chiefly of low evergreens which will bear the knife.

We would here protest against what are termed belts of planting. Some planters seem to have but one idea on this head, by which a most disagreeable mannerism prevails; the perambulator of such grounds generally feels some desire to know what the character of the country may be beyond this impenetrable screen; but this is resolutely denied him. The walks, in such situations, will frequently be found damp and ill-favoured; whilst the verges of grass, if there be any, will become lank, weak, and of a poverty-stricken appearance, for want of a proper circulation of air. Why men should fancy that boundary planting should be of a continuous character, we are at a loss to imagine; but they will tell you it is a "shrubbery," and that they think a sufficient answer. We, however, do not find these long shrubberies in the works of our best painters. As for belts of mere trees of deciduous character, they are even worse still; for where a place is severely limited on that side, such belts at once proclaim the severity of the limits to every stranger the moment he casts his eyes on them. These, when they have been simultaneously planted, in age acquire the character, at a distance, of a row of gigantic pea-stakes, not only totally devoid of interest, but really oppressive to every cultivated eye.

In all these things it becomes the planter to make himself quite "at home" as to the individual character of the grounds, and the adjacent country or neighbourhood, before he ventures to decide on his shrub-masses or trees; keeping, of course, ever in view the mansion or house, with the impress sought to be given to the whole composition.

Here we must direct attention, for a moment, to a principle of importance in all grounds, but doubly so when severely limited. This is what painters and landscape gardeners term intricacy of outline. This applies

to both the sky and the ground lines, and is characterised by ever-varying curves, deep indentations, and even by abrupt breaks, leading the eye of the spectator occasionally into recesses, the precise termination of which cannot at once be ascertained. The application of this principle to the general character of shrub-masses, plantations, &c., requires a mind well skilled in lines and forms. It is for the purpose of bringing this principle fully into play that we advised bold curves, sometimes even abrupt, in walks, in our preceding article on that portion of the subject; for the style of planting will, of necessity, be ruled, in some degree, by the direction and style of the walks. We have met with some persons in our time, high up in the art, who have affected totally to despise the character of walks. This, we think, ought not to be; and the only thing that can justify them is the fact, that common-place ground-workmen, mere line-and-rule men, lay too much stress on walks. Be that as it may, we return to the point—intricacy of outline; and advise that the designer stake out his marginal planting with spirit.

It is of immense importance, in hundreds of cases, to conceal or break the limits of a garden; and as the principle of seclusion necessarily involves the use of hard lines, as fences or continuous planting, every skilful appliance of the planner should be brought into play; and here planting stands pre-eminent. In order to get rid of dead lines where a tame level prevails, recourse may be had to mounds or raised surfaces, provided such can be reconciled with the character of the interior plot, and the features beyond, if seen. Undulating surfaces of this character will be incomplete without furniture; and here again the judicious planter's services are required. In low breaks we have seen low ivy fences produce a useful effect, and behind, or about the elevated parts, trees of rapid growth and spiry forms may be made to arise; thus marking a bold sky, and producing a bold ground outline, which, conjointly, will serve to draw the eye from minor defects.

It must here be advised, that in all grounds of a "dress" character, evergreens constitute the majority, perhaps, in the proportion of three to one. If this be correct as to larger grounds, how much more important in the grounds of the villa; or, indeed, any grounds bounded by the hard, dry, and cutting lines of walls, buildings, and the other unbearables of suburban residences. It will be necessary, in carrying one principal perambulating walk round the exterior of the grounds, to approach, at intervals, very near the boundary line, and this of necessity, not of choice; of course, the skilful designer will take care to make his nearest approaches where the best exterior features present themselves, if any must be called in; indeed, it will occasionally be advisable to do so, when they are unobjectionable, and subserve the interior composition. In such situations low walls may be used; perhaps the basement made massive with extra stones, bricks, &c.; and here such things as Irish Ivy, Periwinkle, Evergreen Berberries, or even masses of the Rhododendron, kept low by pegging down, may be planted thickly.

The style of doing this, however, and the characters of the planting, should be ruled, in some degree, by the exterior scenery; they should partake somewhat of its style, if possible, in order to sustain unity of expression and continuity. By such means the harshness of mere wall levels may be much softened, and, where it is necessary to take up the usual fencing, the point of junction may be totally concealed by planting.

In carrying this principal or exterior walk around the villa grounds with much freedom of outline, for the sake of intricacy, it will be necessary occasionally to take some liberty with the interior area; care must be here taken, however, that such bold curves do not trespass on those portions of the grounds which are, or ought to have been, appropriated to special objects; above all, not to break in on the breadth of the lawns, which are one of the most important features to all country residences, and of which we shall say more in the proper place.

Amidst all these arrangements, one material thing must be thought of, and that is SHELTER: without a degree of this many places can never be rendered comfortable. It not unfrequently happens, that by a judicious arrangement of the materials for shelter, the other purposes before alluded to may be assisted. This must be well borne in mind by the designer from the first. He will remember, that the planting of trees and shrubs for this purpose, will, at least, affect ultimately his sky outline.

Another portion of the subject may be referred to here, as bearing on the planter's department, and that is, the reconciling awkward levels by planting. We do not wish it to be inferred that we advise the destruction of natural undulations in grounds; far from it; we would do all that could be done generally to preserve them, and to heighten their beauties. It sometimes occurs, however, that undignified patches of ground come to hand, which can by no means add to the beauties of the place, but rather detract from it; such spots may be made extremely useful, if well planted; elevation may be gained, and ill-advised labour in removal spared.

It may here be observed, that as our space is limited in regard of this subject, we have endeavoured so to generalise our remarks as to make them applicable to the grounds of most ordinary country residences of moderate size. The treatment of Parks, as to planting matters, is a different affair, and must be handled separately. The ingenious reader will be able to see what part of the observations apply to the suburban villa: most of the remarks on matters pertaining to some limitation of space, applying to such gardens, bounded, as many of them are, by walls and buildings.

In the next we will follow up the subject by remarks on interior ornamental planting. E.

"THE insinuations of 'Q-in-the-Corner,' reflected very seriously on the character of those to whom he alluded, and not unreasonably, as I think, do they feel themselves aggrieved."

So writes to us a friend, and if this be so—if any gentleman feels himself aggrieved by those insinuations, most unreservedly, and most heartily do we express our regret that any such pain and annoyance should have been caused. But whilst we thus express our regret, let us add, that if the parties whose evidence we heard had not failed in sustaining their allegations, both "Q" and ourselves must have been fully justified in standing forward as accusers.

Those who gave that erroneous evidence we might fairly proclaim; but, as we would rather err by avoiding even the appearance of betraying confidence, their names must be withheld.

Before finally taking leave of this subject we must add, that we spoke—as we must always speak—in condemnation of what, at the time, we considered as proved evil; and in being deceived by witnesses, we incurred no greater failure than has befallen judges in the courts above.

Many of our readers being cultivators of their own glebes, and others holding a few acres of arable or pasture land, with the necessary accompaniments of cows, sheep, and pigs, we have thought it desirable that they should benefit by the knowledge of some practical farmer. Such a coadjutor we have found in Mr. Joseph Blundell, a Hampshire agriculturist, and we publish to-day his very seasonable notes upon sowing Spring Wheat. If any of our farming readers require information upon any point, either new to them, or which may have passed from their memories, they may now transmit their queries to us with a full confidence that the replies will be trustworthy, whether those queries relate to their crops, or to the treatment of animals, either in health or disease.

COVENT GARDEN.

THERE has been no superabundance of garden produce during the past week; and although the weather has been milder, and more spring-like than hitherto, the check which everything received by the late frosts has kept the market free from anything like an abundant supply. There is not, however, any scarcity, except in the way of fruit. All other articles are to be had at reasonable prices.

In VEGETABLES there have been some novelties, such as forced *Early Horn Carrots*, of pretty good quality. A few *Turnip* and *Early Frame Radishes*, the former being like small cloves of garlic, or tiny pickling onions. In the usual way, we had a good supply of *Savoys*, at from 1s. to 2s. per dozen. *Greens*, 4s. to 6s. per dozen bunches. *Brocoli*, 2s. to 3s. per dozen. *Brussels Sprouts*, 2s. to 3s. per half-sieve. *Turnips*, 3s. to 4s. per dozen bunches. *Carrots*, 6s. to 8s. per dozen bunches. *Celery*, 9d. to 1s. 6d. per bundle. *Onions*, 4s. to 5s. per basket. *Asparagus*, 5s. to 8s. per bundle. *Sea-Kale*, 2s. 6d. per basket. *Rhubarb*, 1s. 6d. per bundle.

As we have said, FRUIT of all kinds is very scarce.

Apples make from 10s. to 14s. a bushel, for dessert kinds, and 6s. to 10s. for kitchen.

FLOWERS are very abundant, and consist of *Camellias*, *Cinerarias*, *Primulas*, *Geraniums*, *Cytisus racemosus*, *Tulips*, *Lily of the Valley* (forced), *Heaths*, *Epaerises*, and *Hyacinths*.—H.

GOSSIP.

THE general opinion among the practical planters who witnessed the experiments with Mr. McGlashen's lifting machines in the garden of the Horticultural Society was, that this mode of transplanting is less safe and effectual than any of the schemes which have been approved of for the last few years. It is less safe, because the *best parts* of the roots are sacrificed by it—the lateral ones being necessarily cut through in driving down the spades, and the under roots are torn up by violence or main force. It is less effectual, because there is no provision, except round the sides, for maintaining the ball of earth from crumbling down.

"The object of the inventor of this apparatus," as we are told by a non-practical contemporary, "was to lift plants from three feet to sixty feet high without disturbing their roots." The working of the machine is, therefore, in direct opposition to the "object of the inventor." "The inventor," says the same contemporary, "desired to test his power as severely as possible;" and in that he succeeded, to the satisfaction of all who had seen it and any of the severe schemes hitherto applied to the moving of large plants.

"The advantages of the apparatus," we are also seriously told, "consists in its lifting a tree and keeping it upright while being transplanted, instead of being broken and bruised by being thrown on its side, *as is invariably the case in all other modes of transplanting!*" The italics are our own, to mark our surprise at so much ignorance on the part of the writer of the commonest operations of the day by practical planters. Does Paxton thus throw down large trees for removal? Do Beaton, or Barron, "invariably" break and bruise all or any of the large trees under their operations? Certainly not. And how did Mr. Scobie, Lord Holland's gardener, remove a "large Weeping Ash" lately, with a ball of from seven to eight tons? Why, "in the upright position;" and "now the tree is making shoots as vigorously as if it had never been transplanted." It was not torn out of the ground with main force, neither was it thrown down on one side. It was tunnelled under the roots, and a truck, on rollers, was pushed into the tunnel. On this truck it was carried upright after the roots were released all round—a proceeding now very commonly resorted to since the system was explained by Mr. Beaton in these columns. Mr. Barron's planting-carriage differs little from that invented by Mr. McGlashen; but Mr. Barron disengages the roots before he applies the machine; and those who prefer the Scotch machine must do the like, before they can calculate on the safety of the operations on any tree

that is more likely to suffer from extreme violence than a common Poplar.

As we are interested in all the practical questions about planting, and wish to see the successful working of Mr. McGlashen's new machine, we shall here endeavour to point out the conditions under which it is at all safe to apply it for any useful purpose. In the first place, we deprecate and protest against any scheme by which the roots of a tree are to be torn asunder by force, or cut through the middle by blunt instruments. Therefore, we would not introduce the "spades" until we had the sides of the ball cleared out with spade, pick, and fork, in the usual manner; following out, and retaining all the roots which spread laterally. At this point, Mr. McGlashen's spades, or, as we would now call them, *gripers*, are the best contrivance for that purpose that has yet been brought before public notice, inasmuch as that they now fill up *a want*, which Mr. Barron—but more cumbrously—provides for, and which Mr. Beaton has not thought of supplying, if he even thought it necessary; and we should say that, supposing "his truck on rollers" to carry seven to eight tons of ball, and that that quantity of earth was sufficient for the largest tree, we cannot see how he could carry a very large tree, or a top-heavy one, without some mechanical contrivance for holding the tree on the perpendicular, and for holding the ball together, both of which this new scheme with spades, extension rod, and collar, is eminently suited for effecting, and, as we have just said, better than anything that has been thought of previously. The roots being freed in the old way, the ball reduced to what size the planter deemed sufficient for a given tree, then squared and reduced at the bottom, and it is in the right condition for the hold of the gripers; these should then be placed the same way as at present, only not so close together, where a strong root runs out beyond their sphere. Then applying the extension rod, the gripers would take hold as effectually as at present, without such a maiming of roots or fibres. The ball being thus firmly grasped all round, the next operation would be to release the tap roots, if any, by reducing the bottom of the ball with a pick, and by going deeper, or not, accordingly as the presence or absence of bottom-roots suggested. After this, the necessary force for lifting and carrying is all the strength that need be applied; and if either the soil was loose, or the bottom of the ball was in any danger of crumbling away, a "false bottom" could easily be secured by fastening the four corners to the sides of the corner spades, after the manner of hook and eye.

We have heard it suggested, that the lower ends of the spades should be turned inwards, to the extent of nine or ten inches, and when this projection was driven in under the ball, all round, there would be little need for any more security for the safety of the ball. Hence, the only improvement gained by this machine is the more efficient security for lifting and carrying the ball. As to forcing a plant out of the ground by actual pulling—a cabbage-plant would suffer by it.

It is rather a startling fact, that what appears to be one of our best late *Grapes* is nowhere mentioned in any work upon their culture. Mr. Errington writes to us as follows upon the subject:—

“On reading the accounts of its merits, a short time since, I was struck with the idea that the *Trebiana Grape*, of which I was ignorant at the moment, was a grape which ought to be more generally known; and I consequently determined to make inquiries concerning it. It so happens that I have fallen into excellent hands—no less than our worthy old friend Donald Beaton, and Mr. Tillery, head-gardener to the Duke of Portland, at Welbeck, a place noted for vines ever since the days of Speechly. I feel perfectly assured that the readers of this work will be pleased with extracts from the originals, and which, I think, I have permission to make.

“Mr. Beaton: ‘The *Trebiana Grape* is an Italian variety, which was introduced to England about twenty-six or twenty-seven years since by the late Earl Powis. I first saw it at Walcot, in fruit, in 1830. When Mr. Forbes was gardener there, he said it was the best *keeping* grape they had. Of all the plain-flavoured white sorts this *Trebiana* was the best keeper, the *Tokay* the next best; and as the *Tokay* is well known, and the other little known, it may suffice to observe that both are about on a par as to growth, strength, crop, and period of ripening, flesh, and flavour; but the berry of the *Trebiana* is not so long as that of the *Tokay*, nor so creamy-looking after Christmas. In the same house, the *Trebiana* would not shrivel so soon as the *Muscat*, and both lasted longer than the *Tokay*; but neither the *Tokay* nor *Trebiana* came to table so early in the autumn as the old *Muscat*. You may recommend it, with the greatest confidence, as the next best white Grape to the *Muscat of Alexandria*.’

“Mr. Tillery says—‘I have great pleasure in giving you a description of the *Trebiana Grape* grown here. It was imported from Portugal, some years back, along with other varieties. It is, apparently, a seedling between the *Muscat* and the *White Portugal Grape* of commerce. Forms a fine shouldered bunch—colour, a beautiful pearly tint, like a well-ripened *Muscat*, and has the merit of keeping unshrivelled until the end of February, or even March, if well ripened. I know of no white grape so fit a companion to the *West's St. Peter's* for the last crop.’

“Little comment is necessary here; my authorities are good ones. Any apparent discrepancy between the two may be very easily reconciled without impugning the opinion of either. For my part, I do think it a truly useful variety, and well worthy the attention of those who want to produce *fresh white Grapes* in February and March, as companions on the table with the *St. Peter's*, *Barbarossa*, and other *black Grapes*. Its *real habit* I must still learn; but from Mr. Beaton's observing that it is a *late ripener*, and Mr. Tillery's proviso that it must be *well ripened*, I infer that it belongs to a class of *Grapes* that not only endure, but require much heat, of which the *Muscats* and *St. Peter's* are notable examples.”

Mr. Collinson writes to us as follows:—

“In your notice of the prices of several lots of *Shanghai fowl*, at Stevens' auction of March 1st, I perceive it stated that the cock bred by me, which sold for 40 guineas, was deficient in weight.

“As this is calculated to give the thousands of your readers, who will be impressed by the handsome sum he realised, an erroneous idea of the bird, I think it necessary to state, that about ten days before he was sold he weighed over 11½ lbs., fairly, and without any preparation, as he was running with half-a-dozen hens; and I have no doubt that in some hands he might have been presented to the notice of the public at upwards of 12 lbs. Your informant may, probably, have been misled in his judgment of size by its having been cramped in a basket, as also from it being a very thick-set, short-legged bird, and so remarkably fluffed that the thigh was quite invisible.”

We have been asked by more than one correspondent, referring to *Dr. Malfatti's experiments* published in our last number, “whether the results there stated to have

been derived are consistent with the principles of botanical science?” To this there can be but one reply. They are entirely at variance with those principles; and we believe that Dr. Malfatti's experiments, if any one thinks it worth while to repeat them, will be found totally erroneous. It is quite possible that the sap of one plant might be transfused into the vessels of another plant of a totally different Natural Order, for the rising sap of all plants is nearly alike, but as soon as the transfused sap had been elaborated in the leaves it would be completely changed into the peculiar juices of the plant bearing those leaves. Dr. Malfatti, however, tells us, that merely growing in contact with another plant imparted to the Potatoes its flavour! We shall publish, from time to time, the proceedings of the Royal Agricultural and of other Societies, but we cannot be responsible for the statements they contain.

We are glad to find, among other symptoms of Irish exertion in the right direction, that a *Horticultural Society and Garden* are in course of establishment in Tipperary. Any persons having superfluous hardy choice shrubs which they could bestow upon the infant institution, will do well by writing to Dr. Hemphill, of Clonmel, to ascertain if they would be acceptable.

We have reason for believing that there is some misapprehension as to the intentions of *The Bath and West of England Agricultural Society's* rules relative to the Exhibition of Poultry, at Plymouth, this summer. We have had a letter from Mr. Gray, who asks us to announce that “The best birds have the 60s. prize; the second best have the 40s.; and the third the 20s.” This, however, does not clear up the doubts existing, but we advise our readers to wait for fuller explanations which we are promised.

BULBS.

(Continued from page 440.)

GASTRONEMA.

GASTRONEMA CLAVATUM.—From a memorandum which was inserted in the Dictionary, to the effect that *Gastronema clavatum* was lost, one of my bulb correspondents wrote to say that he had it, that it bloomed with him the summer before, and that Mr. Carter, the well-known seedsman of Holborn, had it on sale, under the name of *Cyrtanthus uniflorus*. That is the name by which it was published in the “Botanical Register,” in 1816, or 1817; but Dr. Burchell, who gathered it with his own hands, and who first brought it to flower in his own garden at Fulham, had seen as many plants of it in Africa with two flowers on a scape as with one. In outward appearance the flower has not the least resemblance to a *Cyrtanth* flower, yet from the private mark the name must be justified, for undoubtedly it is a true *Amaryllis*, like all the *Cyrtanths*. Seeing, however, that the different sections of *Amaryllis* are so very different in their outward looks, it is much easier for us to mind them by having each section under a different name, as *Brunsvigia*, *Valotta*, *Cyrtanthus*, *Gastronema*, and *Nerine*, when we can prove it to be a distinct member of the family. It is from this and the next species, when they come to be crossed with *Cyrtanthus striatus*, that I anticipate the great desideratum—rich carnation-striped flowers, and the flowers as regular in the outline

as those of *Valotta*, but wider in the mouth;—then, and not till then, we shall have florists' flowers that will drive all the Tulips back to Holland and Dutch water.

Gastronema clavatum is a very small bulb, from the eastern parts of the Cape territory. It goes to rest all the winter, begins to grow late in March, and flowers at the end of summer; but not being much bigger than a *Crocus* bulb, and being very scarce, it should be grown in a pot in the best yellow loam, very much reduced with the best silver sand; a deep pot, four inches across, would be large enough to flower five of these pretty bulbs; the drainage must be perfect, and once in five years would be enough to change the soil. The leaf is not unlike a *crocus* leaf, of a milky-green colour; the flower scape is from six to eight inches high with one, sometimes two, flowers, nodding a little to one side; it is not much bigger than the flower of a large white *Crocus*, but differently shaped, and pure white, with six crimson bands, one up the middle of each division of the flower; the top part of the flower spreads out wide open. Dr. Burchell's bulbs of it flowered in the open border, but the wet killed them in winter.

GASTRONEMA COCCINEUM.—If one had the face to assert, twenty years ago, that anything new, in the way of bulbs, could yet be discovered in our Cape Colony, he would be botanised out of the country. Masson, Forbes, Burchell, and Bowie, and a host of private searchers besides, had so scoured the country from one end to the other, that nothing worth looking at were left behind, as the story went. "But stop a wee!" Since I began writing this page, a drawing of a Chandelier bulb (*Brunsvigia*) was set before me, perhaps the finest of that section, and I know it has never yet been described. In 1846, I had three bulbs from above Algoa Bay, and Dr. Herbert, to whom I sent two of them, could not even guess what genus they belonged to. Much about the same time, Mr. Backhouse, of York, had one of the handsomest of all the *Tritonias* (*aurea*), and here is another of his recent introductions, one of the very prettiest bulbs in all Africa, south or north; and the probability is, that scores, just as handsome, are yet to be had there. There was a capital book published on "The Genera of South African Plants" in Cape Town, in 1838, by W. H. Harvey, Esq.; 100 kinds of Amaryllids and 300 Irids are described in this book, and 8,500 species of Cape plants in the whole. According to the review of it which I have read, this book would assist in getting hold of very good things yet from the Cape. But let us hear about our newest Amaryllid from hence, *Gastronema coccineum*. This very handsome species is four times as large in all the parts as the last, but with only one flower on a scape, which is four or five inches high, hollow, and of a milky-green colour. The flower is stalkless on the top of this scape, with a long greenish tube, which is curved from the pod; the throat expands wide, and is of a deep rose colour, and with six crimson lines running down from the bottom of the segments on the outside; and opposite these, in the inside of the throat, are six white bands, and each of these white bands has a crimson line up the centre. The segments, or six divisions, of the flower spread wide open, and turn back a little, as if on purpose to let you see the lovely markings below. These divisions are of one colour, deep rose, thus forming altogether one of the richest of all our new bulbs, and one which ought to be in every collection, or selection, of bulbs in the three kingdoms and in the colonies thereto belonging. It is as easy to grow as *Valotta*, with nothing but loam and sand. As all these Cape Amaryllids delight in friable loam of different textures, according to the size of the bulbs, and as they do not like to be disturbed from pot to pot, nor to have the same soil changed for years together, it seems madness to add peat or leaf mould for them, as is done in some

nurseries; the effect of which is, that after the first year or two the peat gets rotten and sour, and the leaf mould turns to a black slimy mass; the roots feel the bad effects of this; they begin to canker, the leaves get more and more sickly, the bottoms of them inside the bulb die off without ripening, and bring a mortal disease to the very heart of the system; and if another growth is made, the leaves are all spotted and blotched; and of all the hopeless things which we attempt to put right, this is the most desperate and hopeless.

GEISSORHIZA.

GEISSORHIZA, or Tile-root.—These are Cape Irids. In the "shipping list" for May 1846, it will be seen that H. M. ship *Winchester* arrived in England from the Cape of Good Hope; and by that good ship I received one of the finest assortments of bulbs that ever was made up there, or anywhere else, a list of which now lies before me, or rather is pasted in my *Album*—a curious old sort of book, which has served me for years to hold things which were too heavy for my brains. There is a memorandum in this list, saying that Mr. J. C. Lacy, apothecary, Port Elizabeth, Algoa Bay, South Africa, was then agent for a wanderer in those parts, from whom seed-roots, bulbs, and 37 kinds of *Zamias*, could be had on very low terms, for cash. Among my bulbs were a large number of species, or rather kinds, for there is not a man on earth who can tell a species from a variety, in nine-tenths of the generality of Cape bulbs. They are so numerous, and run into each other so much, that, as Mr. Havey said in his book on Cape plants, when they all open after a shower, the country looks as if there had been a "shower of butterflies."

GEISSORHIZA SECUNDA, if it would flower all the summer, would make the prettiest sky-blue bed of all the plants in creation—but it only blossoms for three weeks at the end of spring, and is too small to be trusted out of a pot, yet it is a very hardy greenhouse or frame bulb.

GEISSORHIZA VAGINATA AND *OBTUSATA*, I think, are the two best kinds, at least they are equally handsome to any in the genus; *Obtusata* is a very handsome little bulb, with rich cream-coloured flowers, which are streaked with pink on the outside; and *Vaginata* is akin to it, but very different in the flower, which is of three colours—the bottom is a rich dark purple, the middle a soft yellow, and the tops of the segments, or lobes of the flower, are marked with a large dark blotch. There are also *Rochea*, or *Larochea*, and *setacea* with *cavisa*, and the first three named used to be common in the seed-shops some years since.

They are all best managed in pots, and a number 48-pot will flower five of the largest roots, and seven of the smaller ones. The best soil for them is good peat, and one-third sand, and they should be potted at the end of September, and be treated like *Ixias* all the winter; they flower from the middle of April to the end of May, and soon die down after that—as the Tulips do.

GELASINE AZUREA.

This is quite a new genus of South American bulbs, of which several kinds have been seen, but not brought over alive. Mr. Tweedie discovered the present species "in stony places near Rio Grande," and it is as hardy as a *Gladiolus*, and with small blue flowers, and the leaves keep on almost all the year round; very sandy loam, in a border with the different species of *Zephyranthes*, is the right place for it.

GETHYLLIS.

With the exception of *Carpolyza*, the different kinds of *Gethyllis* are the smallest of all bulbs, belonging to the order of Amaryllids, and they are all from the Cape. *Ciliaris*, *Afra*, and *spiralis*, are common enough at the Cape, and generally come in a collection from the Cape

dealers. The bulbs, on their first arrival, look much like Crocus bulbs, with longish necks. They have pretty, white, starry flowers, and two of them, *spiralis* and *Afra*, are bluish on the outside, and look very pretty in the bud. *Ciliaris* flowers without the leaves like a true Amaryllis. The leaves are not much stouter than those of very young Onions, but the most curious thing about them is that the seed-pod is buried in the neck of the bulb, and that is peculiar to all the kinds. No one in this country knows anything of the rest of them, except by report. Masson gathered specimens of three or four more kinds of them; and long ago, there was such a rage for numbers of plants, instead of fine flowers, that people actually marked the names of dead plants in their books and catalogues, thinking they might get them before the year was out; and in that way many names are in black and white of plants that were never gathered in a living state. There is an extremely rare kind of *Gethyllis (undulata)*, which I once thought I had, but was mistaken. In the dried state the leaf of this singular bulb is the most curious of all the bulbs known. It is six inches long, or longer, a quarter-of-an-inch wide, flat, and both edges are wavy in-and-out, as regularly as if it were done so with a crimping-iron, and on the swell of each undulation there is a hair-like bristle sticking out; and the leaves of *villosa* are as full of long hairs as a cat's tail, and some of them as firm as his whiskers. They all do with the same soil and treatment as *Carpolyza spiralis*.

GLADIOLUS.

This genus of very curious and very diversified originals has gained a step or two in the way of improvement at the hands of the cross-breeder, and the cross kinds have acquired such a hold on garden patronage, and their culture, propagation, and history, are now so well understood, that we see every point in their history and management discussed, and that more ably and freely than is done for the Tulip, Hyacinth, or Ranunculus. Therefore, I need not take up time and room in this series about them, farther than to remark, that we do not owe the success of the crossing in this genus to the industry and intelligence of the gardener, so much as to the scientific views and precepts of Dr. Herbert. The result obtained by crossing *Gladioli* is only as a drop in the bucket to what may be revealed when the industry of a generation of able and willing minds is brought to bear on the great mass of ornamental bulbs, of which my notes take cognisance of hardly but one section—that which contains the half-hardy kinds. Before I finish my say on this subject, I hope to be able to get in the point of the wedge, which must, sooner or later, split the great stumbling-block which lies so awkwardly in the road to improvement; and when the wedge is once fairly introduced, there will be no lack of strong bootmen to drive it on, from time to time, until border and pot bulbs become as plentiful as blackberries, and as gay as butterflies and moths.

HABRANTHUS.

The genus *Habranthus* is associated in my mind with "Gretna Green." Not, however, in the way of run-away or clandestine marriages, but as being the best known point to strangers in that line which separates two very distinct races of people—the English and the Scotch. What the real difference is between these two races neither the lawyers nor the philosophers can tell us; but that there is a difference, and a very marked difference, too, no one who knows both the races can contradict. Then, if I make *Habranthus* a Gretna Green between two races of bulbs, that are quite as dissimilar in their ways as are the English and the Scotch, and call the bulbs immediately on this side

of the Green, *Amaryllids*, and the bulbs on the other side of the Green, to a certain extent, *Hippeasters*, how will a stranger know an Amaryllid from a Hippeaster? Much easier than he could "the natives" from each other. But this kind of knowledge is not, and cannot be taught in schools, or in books; it must be learned by that kind of mental philosophy by which we can tell two sisters or two brothers in a crowd at first sight; and this philosophy is called intuitive perception. After one knows a good many kinds of bulbs, there is no great difficulty in referring a new kind to the group to which it naturally belongs by this perception. Some kinds of *Habranthus* would be referred to *Amaryllis* by this philosophy, and others of them to *Hippeastrum*, by the same perception. So that the line of difference between *Amaryllis* and *Hippeastrum* is lost in the very midst of *Habranths*, and whoever finds it out will make a little fortune of it; and the following description of species may help the inquiry, as well as introduce a race of beautiful flowering-bulbs to the notice of the reader.

HABRANTHUS ADVENUS, alias *Amaryllis advena* and *Hippeastrum advena*.—This species is not mentioned by name in the Dictionary, but is included under *Hesperius*, which is only a fanciful name given by Dr. Herbert, to cover three or four kinds, which, like *advena*, form the western extremity of the genus in Chili—as the Greeks and Romans distinguished Spain and Portugal as their Hesperia, or the far west. The bulb of *advena* is dark, nearly round, and not quite so large as a middle-sized hyacinth bulb. Leaves narrow and blunt. The flowers come generally six on a scape, bright red, with the lips of the segments yellow. *Pallidus* is only a very small variety of this, named by Loddiges, in the "Botanical Cabinet," and the same variety is called *citrina* in the "Botanical Register." *Miniatus* is the third variety of Herbert's *Hesperius*—it has pale reddish flowers, and much larger than those of *pallidus*, but not so large as those of *advena*, which are nearly as large as a *Valotta* flower. *Miniatus* and *advena* are well worth growing—*pallidus* is not.

HABRANTHUS BAGNOLDI.—So named after Captain Bagnold, who first brought it over from Chili. A large black bulb, with a long neck, blunt sea-green leaves, not more than a fourth-of-an-inch broad—a green scape, with six beautiful large yellowish flowers, spotted and tinged with red—the peduncles are very long in this species, quite three inches; the bulb is from the southern parts of Chili, (*Hesperia*), and grows in strong or gravelly ground, as do the three last, and all of these must have good drainage and sandy loam. They all flower in summer, before the leaf, and grow through the winter.

HABRANTHUS BIFIDUS.—From Buenos Ayres, where the bulbs are not so dark as those on the western side beyond the Andes. Leaves not quite half-an-inch wide—four large dark purple flowers, darker, and lined with green below, with the rudiment of a bearded membrane, or what I call the eye-lash—the very bottom of a bulb-flower without a tube, I call the eye—the Nectarian membrane, diminishes, in different kinds, till at last there is only a ring of it round the bottom, and when this ring is fringed, or bearded, as they call it, I call it the eye-lash as more expressive, and this eye-lash brings *Habranthus* in contact with *Hippeastrum* for the first time; and if ever the two genera can be crossed together it will be through the species thus marked with a beard, or eye-lash. There is another variety of this named *litalis*, which Tweedie found at Monte Video, growing within the tide mark.

HABRANTHUS CONCOLOR.—One of the newest of the genus, a native of Mexico, whence Hartweg sent it to the Horticultural Society. The bulb is black, the leaves broader than in the more southern ones, being fully half-an-inch wide, a foot high, and sea-green, and the

scape is one-flowered, the flower a greenish, or pale yellow, but rather handsome in its way.

HABRANTHUS GRACILIFOLIUS and *BOOTHEANUS*.—Two very handsome varieties, particularly the latter, which first flowered with Sir Charles Lemon, to whom it was sent from Maldonado, by Lieut. J. Sullivan, of the *Beagle*. Bulb black, and of the size of a pigeon's egg; the leaves very slender and wavy; light rosy flowers, produced singly on the scape.

HABRANTHUS INTERMEDIUS.—Supposed, at the time it was first described (1827), to be intermediate between *rutila* and *advena*; the first a *Hippeaster*, and the second as above. This species has much of the aspect of some small *Hippeaster*, which, after going through the furnace of scientific investigation for a quarter-of-a-century, I should not be at all surprised to hear would cross with a true *Hippeaster*, and if so, my views about Gretna Green tell in two very different ways; first, as the point dividing two different races; and the next, as the very spot where two of them might go together, at a push, notwithstanding all our private marks. A dark bulb, native of Brazil, with bright green narrow leaves, and wide open flowers of a dull red colour, having a greenish-yellow eye or bottom; apparently, a *Hippeaster*, to all intents and purposes.

HABRANTHUS KERMESINUS, alias *Amaryllis Kermesina*.—One of the very gayest and prettiest flowers, claiming kindred with *Amaryllis*, who was a pretty country girl herself, and whose name was immortalized by Virgil. The bulb is dark brown, not bigger than a pigeon's egg; leaves scarcely a quarter-of-an-inch wide, and hardly a foot long; a sea-green scape, carrying four large deep crimson flowers, of the most vivid tint, and ribbed at the bottom with yellow. A south Brazilian bulb of exquisite beauty. It flowered first with Sir Charles Lemon, from whom it was figured in the "Botanical Register," vol. xix., plate 1638.

HABRANTHUS PHYCELLOIDES.—Another very charming bulb; a native of Chili, with a very different-looking flower from the usual run in this genus. Six of them form a brilliant star spread out, as they are, on long footstalks, or peduncles, from the top of the scape; the opening of the flower, which is more than two inches across, is of the brightest shining scarlet, like the *Phycella ignea*; the bottom of the flower, which is a short tube, is a delicate soft yellow. When crosses between *Cyrtanthi* and *Valotta* become multiplied some of them will look much after the likeness of this beautiful flower. The bulb is large and black, with a very short neck; leaves milky-green, blunt, and about half-an-inch wide. It is, certainly, a puzzle to the most learned, to know how to deal with, and to classify the interminable shades of variations that are constantly met with among bulbs, natives of the temperate zones of the earth; and here is a proof, in this very flower being made into a *Habranth*.

HABRANTHUS PRATENSIS, which was met with by Poepping and Zuillet, in south Chili, growing in the meadows of Antuco, with *Alströmerias*, and which they said had a scarlet flower with a yellow bottom. I know nothing of it besides; whether it was introduced to this country I know not. McRae, one of the first collectors sent out by the Horticultural Society, sent home a dried specimen from Concepcion, Chili, a very beautiful purple *Habranthus*, now called *speciosus*. I know nothing more of this either. *Pumilis* and *roseus* are the same; and a very dwarf, pretty little bulb. *Spathaceus* is a variety of *Angustus*, which I left out till I had the two together. This is well represented in the "Botanical Magazine," 2639, with large purple flowers, edging into the character of a *Hippeaster*.

HABRANTHUS VERSICOLOR.—This is one of the small flowered ones, as *roseus* and *Andersonii*, and worth the whole of them put together. The flower is chiefly white

tipped with red on the segments, and with bright red streaks at the bottom; the scape, the envelope (spathe), and the flower-bud are all of one colour—a rosy-pink; but when the flower opens the parts take to the usual colour; there is only one flower on a scape. *Andersonii* is the next to this, and is dull compared with it and *roseus*. The colour is a mixture of dull red and brown; but there are five or six varieties, all from Buenos Ayres; and all but hardy here, flowering all the summer; and all the dwarf species ought to be set thick in a patch, as there is but one flower on each scape.

HABRANTHUS ROBUSTUS was very common about London twenty years back. It was the largest flower of all the single-flowered ones; the colour a purplish-rose; and as fast as one flower opened the seed-pod from a former one was ready to gape open, full of black seeds, which ripened every year. There are several other kinds, and some of them very pretty, mentioned by travellers, and one is beautifully spotted on a light ground, very much like a flower of *Alstromeria perigrina*. This is called *punctatus*. It is a Chilean species, sent by Reynold to Sir W. J. Hooker. It has its limb very prettily dotted, and is of a rosy colour.

Culture.—Every one of those beautiful bulbs would flower out-of-doors in this country. They all flower from the end of summer, and some of them late in the autumn, according to the time the different kinds go to rest. The whole of them keep green all the winter, and dislike damp and confinement. They rest at different periods from April to July, and after awhile push up their flowers before the leaves. They delight in fresh sandy loam of loose texture, and the border, or pot, cannot be too well drained for them. They are best in borders in front of plant houses; and, as they are green all winter, they must have glass over them; but the bulbs should only be just covered, and be set in silver sand. If any of them should cross with *Hippeastrum* the seedlings would inherit the hardihood of this family, and some would give up their winter growth, and some, perhaps, would assume their full foliage before the time of flowering—three points of very essential improvement. D. BEATON.

(To be continued.)

HOTBEDS.

THESE, however humble, are generally the first attempts at the aristocratic in gardening. It has been my fortune to see them very well managed by artisans, and, in some cases, even by labourers. In almost every case the possessors rose intellectually and morally in proportion to their advanced aspirations in gardening pursuits. I have often been surprised that our farming friends did not take more advantage of the means within their reach. Having all the material, except boxes and glass, nothing but a little labour would be necessary to furnish them with many luxuries in the way of vegetables, fruits, and flowers. Even a rough-made dung-heap would supply them with much, provided they covered the dung with earth, and used one of their waggon tarpaulins as a covering at night.

The drawback to their use is the frequent misfortune that early excess of steam, want of air, &c., dash well-grounded hopes. Hotbeds thus become associated with the mysterious and the never-ceasing pains-taking; while, if set about by the middle or end of March, mystery and labour alike are reduced to a minimum. The making and treatment of these have frequently been referred to, sometimes by myself, and oftener by Messrs. Errington and Robson. Turning back will present full instructions. But as many with their one small greenhouse wish to bring forward many little things for its adornment, and for filling the centre and

sides of their vases, baskets, and beds, and others would like to try their hand at grafting some of the things already referred to, I shall, for the convenience of such beginners, just glance at a few of the essentials to success.

1st. *Material.*—The dung from a horse, and the straw more or less saturated with urine, possess more heating power than that from animals whose fœces are of a cooler nature. Every sort of fresh manure, every kind of rubbish—clearings of flower-beds, tufts of dry grass, rakings of moss—anything that will heat when thrown into a heap, may be managed to suit your purpose. Tree leaves, especially of the oak, are very valuable, because they decay so slowly, and thus yield a genial heat for such a long time. I have often had valuable beds from leaves alone, the half of them being oak, the others beech, and all kinds. If at all moist when collected they will merely require to be built into a bed of the desired size, allowing a foot or eighteen inches for sinking, after all your beating and treading. If collected dry, and stored, they will need watering as you use them. Partially decayed leaves of the previous year will make a good surface-covering. In general, however, it would be preferable to have one part of sweet dung to two of leaves; and in that case, to avoid trouble and waste, the preparation of the dung should be nearly finished before the leaves are blended with it.

2ndly. *Preparing the Dung.*—This is done by shaking the straw and droppings into a heap, watering the latter if dry—allowing it to remain until it has heated strongly, then turning it several times, and watering any dry and white parched pieces, until the whole has become darkish in colour, and though very hot, emits a mild odour, instead of the pungent smell of rank ammonia that too well reminds you of the fumes of harts-horn. Before the last turning the leaves should be blended, as thus they will receive an accession of heat without an undue decay, while the material will be uniform throughout. This is the advice I would give to beginners. By-and-by you may do with less preparation. Being short of fermenting material of all kinds, I waste it but little in previous preparation, but I always cover with a fair thickness of old material of the previous year. Until you gather experience you had better err on the safe side of thorough preparation, keeping in mind, however, that the more sweet, and, therefore, the more reduced your heating material, the more close will it become; and, consequently, the shorter will be the continuance of the heat, as the air will find more difficulty in entering, and when it does enter, find but little to feed upon or consume. Air, or perhaps, more properly speaking, its oxygen, is not only the great preserver, but it is likewise the great destroyer. Heat, from such substances as I have before alluded to, can only take place during a fermenting decomposing process, and that process can only progress when associated with warmth, moisture, and air. This theory kept in mind simplifies all hotbed practice. Hence, one man who sees his way clearly will do as much in the way of securing heat with a small quantity of manure as a man acting from mere routine will do with double. Hence, the ease with which the heat of a bed is renewed when not greatly decomposed, merely by turning it when moist enough, and, in addition, adding a little water if dry. Hence, too, when the heat declines, and we know that the bed is not too decomposed to yield more, the ease with which we renew the heat when we cannot turn the material, owing to a fixed crop on its surface, by merely boring holes round its sides, and pouring in a little warm water, if we have reason to believe the material to be dry. By the opening, and partially and wholly shutting of such holes, an earnest man will regulate heat somewhat at his will; but *only* so long as there is plenty of matter to be further reduced

or decomposed; for when that takes place, no means for increased heat can be given, unless by the addition of fresh matter as linings. I am the more particular here, because I know many are deterred from trying by seeing the huge mounds of dung with frames on them, and surrounded with large banks of linings, in places where manure and litter are plentiful. I believe that every man likely to be benefited by the racy articles on "A Gardener's Pony"—in fact, every one who has such an animal—may enjoy many luxuries to which he is now a stranger. All that will be necessary will be a rigid economising of his manure, not as now, throwing it into a heap to steam and rot at will, but for some time, at least, previously to preparing to make his bed, keeping it rather thinly spread, so that it will not heat much, and, if possible, protect it from wind and heavy rains; and then, when thrown into a heap, as advised, it will ferment and sweeten in a uniform mass.

3rdly. *Making the Bed.*—Whether in a pit, or for a wooden box and lights to be set over it, the mode of proceeding should be similar. We speak now only of the box and light. The first thing is to form a foundation. Unless you are sure against water standing at the bottom of your bed, do not sink it, but rather raise it above the level of the soil, either by faggots, or, better still, by a platform of solid earth, so that the ground falls from it in every direction. This space should be eighteen inches longer and wider than your frame. If you have plenty of material, twenty-four or thirty inches will be better, as a foot or fifteen inches of dung all round beyond the frame will yield a much more permanent heat than merely a couple of inches or so. Then, as to the height of the bed, two feet-and-a-half at back, and two feet in front will be extremely useful *now*. If earlier, you would require a foot, at least, for every earlier month. The mode of making will already be looming before the mind's eye, if what has been said of *continued* fermentation, as necessary to continued heat, be kept in view. No boys or men should, therefore, be allowed to parade, jump, and dance on such a bed. The outside of the heap should be placed at the bottom of the bed, as being less prepared, even though the precaution has been taken in turning of throwing the outsides into the centre. The sides of the bed should then be attended to, building them straight and firm. The dung must be well shaken and mixed over the whole bed, beating it pretty firmly down every few-inches' layer with the fork, while you walk round it, not *upon* it. If your material is a mixture of dung and leaves, as spoken of above, no other precaution will be necessary, as beat as you will, a great body of air will be enclosed. But if there is nothing but sweet dung, as many who have a horse, or can procure manure, cannot get leaves, then, from a fourth to a third of a bed of this size may consist of bundles of prunings, faggots, &c.; and this will not only moderate the fire of the first heat but render it more continuous. A layer of dung must, however, cover the ends of these bundles, or the air admitted would be too much. When thus made, set on the frame and lights—the latter close, to draw the heat up; and as soon as that rises, giving a little air to let off the steam.

4thly. *When will it be fit to use?*—Just in proportion to the previous sweetness of your dung, and the hardness of the tenants. A Pine-apple sucker would rejoice in an atmosphere which would kill an Orange, or a Cape Jasmine. The nose will give a good notion as to when the atmosphere is free from hurtful gases; but what I think is the best criterion for all practical purposes, is noticing the drops of condensed moisture on the inside of the sash-bars in a morning. If these are of a yellowish, dirty tint, trust your frame with nothing; if as clear as the dew, everything will be safe. Even then it will be safest to leave a little air at the back at all times, though it was only an eighth or the

quarter of an inch. Many accidents from sudden sunshine during the day might be obviated by this simple precaution, and especially in circumstances where constant attention cannot be given for many hours during the day. Such a bed will yield a bottom-heat from 65° to 85°; and when we want less, we must either plunge shallow, or bore holes, or remove a piece of the dung outside, opposite a faggot, so that the extra heat may escape, for much air will just cool as effectually as the introduction of a little, in circumstances referred to, will cause fermentation to begin anew.

5thly. *For what shall we use such a bed?* — Just imagine the courteous writers in this work congregated before such a bed, and you saying to them, "There, gentlemen, that is all you can have; make the best of it between you." Are you prepared for the noisy Babel, polite though it would be, of appeal and expostulation — each striving to get a fair share of the prize? One would be thinking of Cucumbers, Capsicums, Love-apples, and ever so many lovelies besides. A second would see a rare opportunity for young tropical plants, and affording a rich luxuriance to his Ixoras and Cape Jasmines. Visions of Pine-suckers, Vine-cuttings, and fine handsome Melons, would cross the mind of a third. A fourth would cover every inch he could get with cuttings of bedding plants, after reserving a corner for some carefully-saved hybrid seeds from bulbs, of which he can so write as to make us feel very little indeed. A fifth would be thinking of tender annuals for his greenhouse—setting up an hospital for some rickety customers, or changing the appearance of some plants by grafting them with fresh varieties; while a sixth, and the type of the most numerous class of all, would be debating how each and all these things were to be attended to in a very small amount of space.

GRAFTING.

I confess that complaints of want of success in propagating by cuttings, and, more especially, by grafting greenhouse plants, as previously recommended, and chiefly, as it was believed, owing to something being wrong about the beds, have led me to the subject just now, but which I hoped to have compressed into a third of the space. Perhaps our Captain will allow me a little more room just to glance at a few other things that such a bed will be a great help to when grafted.

Oranges.—Large plants of these may be done as was mentioned about *Azaleas*, provided the plant is not too large to be laid down on the bed, as setting it upright once a-week, or so, will be quite sufficient for watering: with a little shade the scions will soon take. The bottom temperature may range from 70° to 75°; the top temperature from 60° to 75°. Small young plants, however, are the neatest things to manage. From seeds of Lemons, or even Oranges, sown in a little heat last summer, there will be nice little stocks in the greenhouse now. Set them in the bed for a week, shorten-in their heads a little, then take a small strip of wood and bark from the base of the stock, making a horizontal cut to the depth of the piece removed; prepare the scion, a piece of last year's wood not yet pushed, to fit it, seeing that there is a bud at its base, and at least one more near its point, tie them together, rub with a little clay if you like, and then set in the bed, and keep rather close. The union will probably be effected in a fortnight. Shorten-in the head by degrees, and when the scion grows freely cut away all the stock about it, and harden by degrees.

Camellias may be grafted successfully by the same mode, but five degrees lower in temperature would suit them. There are various modes of notching the stock and scion, so that fitting each other they will be kept more secure; but the above is the simplest, and, perhaps, not far from being as good as any. Under such a mode

I like to cut in a little horizontally at the base of the stock, to furnish room for standing on for a similar horizontal cut of the scion at a bud, in fact, with the exception of removing the strip of wood and bark to fit the stock the scion would just resemble a cutting.

Rhododendron arboreum — *Varieties.* — Almost all these are splendid objects in greenhouses after Christmas, if an average of 45° at night is maintained; and with a lower temperature they will come in later. Nice young plants of varieties of *Ponticum* or *Catawbiense*, one foot or more in height, and with single stems, make stocks. The grafting may be done in a similar manner, or notched, or with the scion a little longer than the cut in the stock, so that the end of the scion rests in the soil. A close hotbed is necessary, but a lower temperature, by from 5° to 10°, than would suit Oranges.

Roses.—Grafting is chiefly done with the Tea kinds, and scarce and tender varieties, so as alike to increase and render them more robust. They may be grafted close to the soil for dwarfs, or at any height for standards. In every case, however, whatever may be the mode adopted, a modification of side-grafting, such as described above, is generally used; the top of the stock, in every case, being allowed to remain, or part of it, to draw up the sap, until the graft has taken, when it is gradually reduced, and at last cut clean off at the junction. It is advisable that growth be commencing in the stock either naturally or by artificial means, before grafting; and, also, that the plant be established in the pot by having been potted some time the previous year. They will then thank you for a sweet bottom-heat of from 65° to 75°; and a top heat of from 55° to 60°; and kept rather close, and shaded from sunshine until the union was effected. We used the Perpetual Rose, the Dog Rose, and several climbers, as stocks; but though I have not tried it, all accounts agree in speaking favourably of the *Manetti*.

Geraniums.—These we recommend grafting in a similar manner. It is a mode not sufficiently adopted for increasing kinds difficult to strike, and giving strength to weak-growing fancies. Mr. Appleby adverted to the subject the other week, and recommends *cleft* grafting. In such hands success will be certain; but when I tried experiments on these tribes I was more successful with side-grafting, leaving a part of the stock above the scion to draw up the sap. As Mr. Appleby has so lately referred to the two groups of *Pelargoniums*, I need not allude to them; but much may be done in this way with the Scarlet Geraniums; and, as they will stand almost any heat, such a bed, and a temperature between the roses and the oranges would suit them. I saw some strong stems of the *Giant*, and *Shrubland Scarlet*, so grafted, at Luton Hoo Park, the other day. Mr. Fraser had them in a hothouse, where he could shade them, and the scion was guarded with moss. I had discarded these strong-growing kinds some time previously, but I got a few cuttings for future use, and already visions of nice standards on these strong stocks of *Flower of the Day*, *Mountain of Light*, and *Golden Chain*, &c., are looming before my mind's eye.

R. FISH.

CONIFERÆ.

(Continued from page 444.)

3RD—SECTION OF PINUS, WITH LEAVES FIVE IN A SHEATH.

PINUS APULCENSIS (Apulco Pine).—So named because of its being found in Mexico, near to Apulco. This species has short leaves, with very silver-grey young shoots. The cones, however, are its chief specific distinction, for they are covered with pyramidal elevations, which are sometimes lengthened out and contracted in

the middle. These excrescences then are very curious; no other pine has such warty appearances on their cones. In the northern counties this curious species requires protection.

PINUS AYACAHUITE (Ayacahuite Pine).—A native of Mexico, and a very remarkable Pine. The fine leaves, in a cluster, are produced on little swellings, or lumps, as it were, which give a singular and curious appearance to the tree. It has very long, slender, tapering cones, often a foot long. A collection of fir cones, arranged in their several genera, would be very interesting and instructive; and a great number may be seen in the excellent museum in the gardens at Kew; but, if my memory serves me right, they are not arranged in their tribes, probably because the gardens do not possess a full series of them.

PINUS CEMBRA (Cembran Pine).—This is a beautiful European species, growing wild on the mountains of Switzerland and Siberia. The wood is of a fine grain, and so soft as to be easily carved; hence the shepherds of the Tyrol, and neighbouring districts, amuse themselves by carving out of it those curious little figures of men and animals so well known over all Europe. The inhabitants extract a fine oil from the seeds, and even use the shells of the seeds to dye a fine brown colour. The trees are quite hardy enough to bear the cold on our highest hills. The roots are very fibrous, and, in consequence, it has been proved that this Pine may be moved when large with more certainty of success than any other. There is a variety from Siberia, but it is of slower growth even than the species which is not a fast-grower compared with other Pines. There is also a curious dwarf-growing variety, which Mr. Loudon names *pygmaea*, and a pigmy indeed it is, forming a little bush from two to three feet high. The Cembran Pine being so hardy, and plants of it so cheap, and producing nuts that yield a beautiful oil, it deserves the particular attention of gentlemen possessing land situated on lofty hills, or even mountains.

PINUS DEVONIANA (Duke of Devonshire's Pine).—In its native country (Mexico) this forms a large handsome tree. Unfortunately, it will not bear the rigour of even our ordinary winters, but is well worthy of a place in a lofty conservatory. The Mexicans call it the White, or Royal Pine, the wood being almost pure white.

PINUS EXCELSA (Lofty Pine).—In its native country this is a noble tree, attaining the height of 120 feet. It grows on the mountains of Bhotan, a district of the gigantic Himalayas, in India. The natives call it "The King of Pines," and, from the reports of travellers, it is deserving that appellation. The branches droop so much that it has also been named "The Weeping Fir." The timber is of the best quality, and it yields an immense quantity of turpentine. It is, however, so scarce in the nurseries, that until the fact of its being hardy is proved, and seeds imported more largely, its culture on a large scale cannot be attempted.

PINUS FILIFOLIA (Thread-leaved Pine).—The leaves of this curious species are, as the name imports, long and slender, and it forms a handsome tree. Being a native of Guatemala, it is believed to be too tender for the open air of this country. This fact, however, remains to be proved.

PINUS GORDONIANA (Mr. Gordon's Pine).—So named by Mr. Hartweg, its discoverer, in honour of Mr. George Gordon, a zealous cultivator of the tribe in the Horticultural Gardens at Chiswick, where the finest specimen of this noble tree may be seen, with leaves fully 16 inches long. The cones are large, and hang downwards, and are remarkable from the fact that they are non-resinous. This is one of the tribe that ought to be in every collection, however select. Though a native of Mexico, it is found to be hardy in the neighbourhood of London.

PINUS GRENVILLEÆ (Lady Grenville's Pine).—A noble, robust species, from the same locality as the preceding, and named by Mr. Gordon in honour of Lady Grenville, the owner of the well-known and richest collection of the tribe probably in the world, at Dropmore, three miles from the Maidenhead Station, on the Great Western Railway. I need not say the place is well worthy of a visit by every lover of rare and fine Coniferæ. The species has long large leaves, and very remarkable cones, which are frequently 16 inches long, tapering to a point. This is, like *P. Gordoniana*, a species that should be planted in every collection in the kingdom.

PINUS HARTWEGII (Mr. Hartweg's Pine).—Named in honour of Mr. Theodore Hartweg, the assiduous and successful collector for several years for the London Horticultural Society, and now head gardener to the Emperor of Austria. Probably Mr. Hartweg introduced into Britain more species of Coniferæ, as well as other plants, trees, and shrubs, than any modern collector. To him we are indebted for the beautiful *Achimenes longiflora*, and several other species. *P. Hartwegii* has a remarkable peculiarity in producing frequently only four leaves in a sheath; they are very long, and thickly placed upon the branches. The tree grows slowly, and seldom exceeds, even on the mountain Campanere, in Mexico, its native habitat, more than 50 feet high. It is rather tender, but has stood out in the open air for several years, in Hertfordshire, at Mr. Baker's, of Bayfordbury. On account of its slow growth and great beauty, it is worthy of a place in the Conservatory in the north.

T. APPLEBY.

(To be continued.)

THE PELARGONIUM.

(Continued from page 463.)

SUMMER TREATMENT.—*Cutting Down.*—After the bloom is over the plants should be cut down, a point of treatment which requires some consideration. The form the plants are to assume again the following season must be borne in mind, and that form foreseen with a prophetic eye. The main branches should be thinned out and placed or left equally on every side, and the branches formed the previous year should be at the end of each old branch. These are to produce the shoots for the next year. Very old wood does not break freely, and that renders it necessary to leave a portion of younger wood equally distributed over the plant. The branches that are left should be as low as possible, and should not extend over the sides of the pot, but be cut within it. The plants will then present a curious, stumpy appearance, with their branches pointing outwards on every side. No water should be given for several days previously to this severe operation. That precaution will prevent a too copious bleeding, or exudation of sap, and in order to continue that favourable state no water should be given after they are cut down till the dormant buds are fairly broke. After they are cut down they should be protected from heavy rains, either by being placed in a cold-pit or under a water-proof covering. When the buds are started then give them some water, but by no means a flooding, but only just sufficient to encourage and stimulate the very young shoots to progress. Should too many make their appearance it will be advisable to thin them, but do not take too many off, because then there would be danger that those that are left might be accidentally broken off, and the shape of the plant in that part would be injured. When these new shoots have made some progress, and the plants are moderately clothed with leaves, they may then be fully exposed to the open air and gentle showers. A top-dressing of soil would then be of great use.

Remove all the loose soil from the surface as far as the roots, and replace it by a layer of loam enriched with some leaf mould or well-decomposed dung. After this is done they may be placed in their summer quarters out-of-doors.

The finest plants of show *Geraniums* I ever saw, were placed during this season upon a levelled manure-heap, the heat of which was nearly over. These plants grew rapidly, and produced strong shoots clothed with the finest foliage, and whoever has such a convenience, I would advise to try at least part of their stock in the same way. To prevent a heat too great, it would be an easy matter to cover the dung with a thick coating of sawdust or old tan, and half-plunge the pots in it.

Where there is not this opportunity they should be placed in an open part of the garden, either upon gravel or coal-ashes, but not thickly together, as if they were of no value now they are out of flower. *A good cultivator will take just as much care of his plants after they have bloomed, and gratified him with their beauty, as he did previous to their display.* They must be regularly supplied with water, and protected from high winds, insects, and anything else likely to injure them.

As soon as there is the least fear of frost let them be removed into the greenhouse. One point must not be forgotten: if they have made roots through the holes at the bottom of the pots, these should all be cut off cleanly with a sharp knife, and the plants replaced for a week or two, and a liberal supply of water given to prevent them flagging. Previously to placing them upon the stages of the greenhouse clear them of all dead or decaying leaves, and arrange the shoots for the following season, by thinning them out judiciously, and tying them into form if they require it. The greenhouse to receive them will, of course, be thoroughly cleansed out, the wood painted, if it requires it, and the glass repaired.

WINTER TREATMENT.—This portion of *Pelargonium* culture may be described in a very few sentences. When the plants are first placed upon the stages they will require more water, because the air in the greenhouse is naturally drier than the open air; therefore, water freely for the first month, and then gradually reduce the quantity. The best time for the watering during the damp months of autumn is early in the morning; by giving it then, the overplus that will run through the pots will have time to dry up before the evening. This will, in a great measure, prevent that plague, *the spot*, as it is called, making its appearance. The floor of the house should be kept as dry as possible, and in very damp, long-continued wet weather, a little fire in the morning, combined with a due admission of air to carry off the damps, will be serviceable. Abundance of air, whenever there is no frost, should be given all through the season of autumn and winter. This will induce that strong bushy habit so essential to the producing fine plants and rich bloom the following season. The green fly very often prevails during the early part of autumn; these must be got rid of by frequent gentle smokings of tobacco. A constant supervision must be bestowed in removing every yellow and dying leaf. If the soil becomes mossy or hard-baked on the surface, let it be stirred up with a pointed stick, the moss removed, and the surface loosened. Heat, in severe weather, should be applied just to keep the frost out, and no more; too much heat would be quite as injurious as frost itself, besides rendering the plants more tender, and less able to bear frost or damp.

T. APPLEBY.

(To be continued.)

CELERY AND ITS CULTIVATION.

If we take the lengthened period of a plant's servitude as a proof of its utility and importance, there are not many that exceed Celery; for coming into use in the beginning of August, we have its services until the beginning of April; and, in some cases, even a little later than that. Taking also its general popularity into account, it is no wonder that its cultivation should form an important feature in the garden operations of the season; and in most of gardens its importance is considered such as to entitle it to the best places that each afford. In addition to this, every attempt made to improve the varieties in cultivation is gratefully received by the horticultural world; and though, as with every thing else, all that is reported "new" is not improvement, yet it must be admitted that much has been done during the last twenty years in that direction; and though we may occasionally see Celery with stalks hollow, or "pipy," yet the proportion is small compared with what used to be the case prior to the period I speak of. The plant being of British parentage partly ensures its hardihood; and we may fairly set it down, that although, in common with many other plants, it suffers from exposure to severe frosts, yet it still deserves the name of one of our most hardy vegetables, and one likely to endure the vicissitudes of the season, so far as regards the changes of wet and dry, mild and severe, weather, with less injury than most other plants.

To obtain good Celery at the earliest possible period, the plants ought to be so prepared, by early sowing and pricking-out, as by the time this reaches our readers to be fit to plant out into the ridges, or other places prepared for it. This, however, is not always the case; yet every one having the means ought to avail themselves of the chance of having early Celery, by sowing a pan or two, and placing it in heat some time shortly after Christmas. The seedlings from this sowing must be pricked out into other shallow pans or boxes, when large enough to handle, and then again placed in heat; and, probably, another planting-out into boxes a little deeper, &c., may be advisable before the season is so far advanced as to allow the Celery being planted out-of-doors. Now this sowing and these prickings-out must be done in an atmosphere congenial to the plant, or rather under circumstances favouring its growth, which is a mild and rather moist bottom and top-heat; and such present themselves in the ordinary hotbed, when made of dung, or other fermenting materials.

A gentle hotbed affords the best possible place for these seedlings, and if it can be so contrived as to allow such an abundance of air as to amount to almost complete exposure, the plants will be also benefited to an extent beyond which it will be difficult to advance by any known means. In this we mean also to include the plants being indulged with the best mixture the compost yard affords, and boxes, pans, or separate pots proper to its welfare being all taken into account as well. All these considerations, together with others of a minor nature, as occasional watering with liquid manure, &c., will, if carried out properly, be rewarded with a batch of fine sturdy plants by the middle of April, which ought then to be planted out in trenches previously prepared on some early border, and where the advantages of shelter from cold winds form a feature in its recommendation. With all these advantages combined, it is likely that good useful Celery will reward the cultivator early in the season, provided that due attention, in the shape of watering, stirring the ground around it, earthing-up betimes, and other duties, be attended to when required.

Apart from the above, yet equally important, if not even more so, is the sowing and rearing of plants, to

produce the main winter crop of Celery. This sowing should be now attended to, as it ought not to be delayed a single day, otherwise some stimulating means must be adopted to bring up lost time; and as we are no advocates for the use of artificial heat where it can be done without, we advise that Celery for the main crop should be sown on some well-prepared bed by the middle of March, or certainly not later than the 25th. As the seed lies some time in the ground before germinating, it is advisable not to be too late. Usually, it will be proper to elevate a bed; sometimes an old hot-bed of the past year may be covered with fine soil, which may be kept in its place by slabs or boards, and the surface being made smooth, the seed may be sown at once, and but slightly covered with fine-sifted soil in which leaf mould predominates. We prefer this to sand on account of the solidity the latter adds to any mixture it makes a part of, and the seedlings are not so able to force their way up through a compact mass of matter, such as is usually found where much sand is used. On this account, we advise a greater proportion of leaf mould to be used as a covering to seeds of tender or uncertain germinating plants.

It is hardly necessary to recommend any particular kind of Celery, as each one in turn is superseded by others, which, after reigning a year or two, give way to other names. This succession of names, (which is often all the distinction there is), has, however, not been altogether useless, for the desire to improve the varieties common with us has banished most of the common pipy kinds of Celery from our gardens, which we were accustomed to see so often in days long since gone by, therefore, we may truly say, that the laudable object of improving our culinary vegetables has certainly gone as far in this one as in any other we know of; and, though there are doubtless limits beyond which it is hopeless to expect to advance, yet these limits have never yet been reached, so that we hope to see varieties introduced capable of resisting that inclination to run to seed, which many otherwise good sorts fall into much sooner than is wished for. Crispness and solidity are also necessary qualities; and, if to these be added hardihood and other good properties, a nearer approach to perfection will be obtained than has hitherto been done. The amateur who chances to have a really good kind of Celery, which produces fine heads without more than a usual share of the good things too often supplied to a favourite kind; and to all who have the good fortune to have a stock of good useful Celery by them at the beginning of April, but little run or otherwise injured by decay, will do well to save some for seed—of course a later period will be the proving point in the North of England and Scotland, but the principle is the same; and though we cannot expect this process to be carried on in every garden, yet those who have the good fortune to have a good solid kind of Celery, a good coloured Beet, good curled Parsley, and some other odd things in the way, had better adopt the plan of saving a little of each, in order to secure these essential things in as pure a state as possible. The inexperienced amateur, and others, we advise to try *Cole's Red Celery*, and possibly his *White* kind also, but we have found the *Silver Dwarf Russian*, and *Seymour's White*, all good in their way at times; but it must not be forgotten that a kind soon degenerates unless means be taken to save seed only from such plants as are known to be good.

J. ROBSON.

SOWING SPRING WHEAT.

THE sowing of Spring Wheat, for some years past, and since what is termed high farming has been more in practice, has attracted an unusual share of attention amongst agriculturists, because, upon the greatest part of our best

soils the cultivation of barley has become very precarious and unremunerative; therefore, a great portion of the land formerly appropriated to the growth of that grain has been found to pay better by being sown with Spring Wheat, and particularly land of a loamy nature, which has borne a crop of turnips, fed off with sheep, eating oilcake or corn in addition. This mode of feeding is now very much the practice, and will probably continue so as long as the production of meat offers more profit to the farmer than the growth of corn. Although the sowing of Spring Wheat has been much on the increase, for the above-named reasons, for the last ten or twelve years, yet the untoward and difficult sowing season of the past autumn has invested the subject with more than usual interest, and is the chief cause of the writer of these remarks taking up the subject. It must be admitted, that in ordinary seasons many farmers sow Spring Wheat, believing it to be good policy, still a greater number will be obliged to adopt this plan from the force of circumstances, or, otherwise, greatly curtail their growth of Wheat, it having been found impossible, in many large wheat-growing districts, to sow the land in the autumn or winter months; and much land that has been sown is so deficient in plant that a crop cannot be depended upon without being resown.

The best sorts of Wheat for sowing in the spring season are, the *Talavera*, the *Nursery*, and a bearded variety, called *April Wheat*. The first-named has been selected, and very much improved, by Colonel Le Couteur, of Jersey, and some excellent samples have been the result. It is of great importance to have Spring Wheat true to its kind, because of its early maturity; the ordinary sorts of Wheat not coming to harvest at the same time, would, in case of mixture, greatly diminish the produce; hence the necessity of careful selection. The *Belle Tue Talavera*, as grown by Colonel Le Couteur, requires a kind dry soil in high condition, and a large quantity of seed, say four bushels per acre when sown broadcast; but upon all soils given to summer weeds it is best drilled, in order that it may be hoed if necessary, in which case three-and-a-half bushels of seed per acre would prove sufficient. It is essential that *Talavera Wheat* should be sown thick, because it does not tiller, or branch out, like some other sorts; it will also leave the ground sooner and come earlier to harvest. The chief drawback in connection with this kind of Wheat is its great tendency to sprout in showery harvest seasons; but as Wheat does not sprout in the harvest field, upon an average of seasons, oftener than once in seven years, in the climate of the midland and southern counties of England, I think a compensation will be found for its sprouting in the extra value of the grain for mealing purposes over that of ordinary brown Wheat. The *Nursery Wheat* is a brown variety, very hardy, and tillers well; it is best calculated for sowing on strong soils, and is, therefore, a desirable kind for use during the present season, there being a large portion of the heavy land either not sown, or badly planted. It is the nature of this Wheat to tiller to such an extent as to make up a large amount of deficiency in the plant. Three bushels per acre of this sort will be found an ample allowance of seed for any soil. The *Nursery Wheat* is much liked by the millers, and it is certainly not so liable to blight as any of the varieties of white Wheat.

The *Triticum Æstivum*, or *Bearded April Wheat*, may be sown with advantage a month later than any other variety usually sown in the spring season. It is the best sort for sowing upon inferior land in low condition, and four bushels of seed per acre will be required, as it does not tiller much. It is rather a coarse brown Wheat, not much esteemed by the millers, but it will produce an amazing crop of corn and straw on good land, and does not readily sprout in a wet harvest.

There are many other sorts of Wheat sown in the spring season which are not deserving especial notice, as their growth is attended with more or less risk as compared with the varieties above-mentioned. As a rule, a large quantity of seed is required for every kind of Wheat sown in the spring months, in order that it may not be required to tiller much, as it will then come earlier to maturity, carry an even head, and, in consequence, avoid the ordinary casualties to which late-sown Wheat is particularly liable, such as blight, &c.

It may be said that the chief inducement to sow Spring Wheat in ordinary seasons, is to substitute it for barley upon good soils in a high state of fertility, where the latter would prove deficient in quantity and quality, and probably destroy the grass seeds sown with it, whereas the clover generally takes remarkably well sown amongst Spring Wheat.

In connection with the subject of sowing Spring Wheat the practical management and cultivation of the land must be considered a most important point; for although the foregoing observations relate to the advantages of certain sorts of Wheat for various soils, yet, in practice, it will be found that they require very different management in preparing the land. The *Talavera Wheat* should not be sown until the land will work freely, and leave a kind and good seed bed, and ought not to be sown earlier than the first week in March, at which period there will be a chance, in ordinary seasons, of the seed coming up immediately, and the plant proceeding towards maturity without any check; and the latest period of sowing this sort of Wheat, with a fair chance of success, is the last week in March. The *Nursery Wheat* may be sown at any time in the spring up to the middle of March; and the *Bearded*, or *April Wheat*, may be sown as late as the last week in April.

The two last-named varieties of wheat do not require any nicety in the preparation of the land, but will be found to succeed best when the soil is comparatively heavy and close, and if the land can be worked, and the seed covered, by the use of the iron harrows, that will be quite sufficient, for the heavier the tillage the more these sorts of Wheat will flourish, and the crop will be less infested with weeds than when the land is sown in a light and kind season; one ploughing will always be found sufficient.

In sowing Spring Wheat, or at any time of the winter, I prefer sowing the land as fast as ploughed; the plan being to apportion the horse-power so that the seedman or drill may follow the ploughs, and every land be seeded and finished harrowing immediately after ploughing, in case of rain setting in at any period of the day. By this means I have often obtained a good season for wheat; whereas, had the sowing been deferred one day, the land oftentimes could not have been sown until weeks or months afterwards.

I prefer sowing Spring Wheat broadcast, except where weeds are expected to appear; I would then drill at five or seven inches apart, but I do not approve of dibbling Wheat for winter or spring season. When dibbled, the Wheat is called upon to tiller and branch out to make up a good plant, in which case the crop would be rendered more uncertain, both as regards quantity and quality.—J. BLUNDELL.

LACED POLANDS.

WITH due submission to Dr. Horner, I think he has left the question of laced Polands exactly where he found it, for beyond his *ipse dixit* I find nothing touching on the question. He certainly says, spangled birds are *the thing*—"it is so, and of necessity;" but it were as easy to have written "it is *not* so." With respect, however, to the characteristics of your humble servant, he is more specific, but, I submit, not less incorrect. He states that I have taken my cue from the Rev. Mr. Dixon, and have misquoted his work: the former is mere assertion, and cannot be the fact, *if*, as he says, my opinions were formed on Polands twenty years ago; and the latter charge, of misquotation, I fling back on the worthy gentleman, by the following ungarbled extract from the work:—"The Golden Polands are sometimes called Gold Spangled, but *surely not correctly*, because, although the bird has spots, those markings are not universal; but many of the *finest specimens* have the feathers merely fringed with a darker colour," &c.; and a few lines further on Mr. Dixon is guilty of an *indiscretion*, according to Dr. Horner, by saying, that "the hen is *richly laced* with dark brown, or black, on an ochre ground."

I am next charged (dimly, it is true) with having seduced an "uninitiated" young friend at Hull into my opinion, by sending him a wing* COVERLET! (*sic*.) Let me assure the doctor, upon my honour, that I never sent a feather to any person except yourself, and have, moreover, no "young

friend," or correspondent, at Hull. I need not further allude to this part of his letter, where "function is smothered in surmise, and nothing is, but what is not," beyond complying with his request, that I will send you some crop feathers, which are herewith enclosed. [These are precisely like the engraving we gave last week, and are breast feathers.—ED. C. G.]

The doctor appears to have been won by that "gay, young, fresh, and beautiful wooer," gold, as he says that he sold some spotted birds (*may I add*, the purchaser also) for six guineas, whilst some *laced* Polands remained unnoticed—*unnoticed* by me, certainly, notwithstanding a most minute examination of those exhibited. *By the way*, where did he get his laced birds, if, as he supposes, "Scrutator is poking fun," and laced birds are altogether fabulous animals. "Depend upon it Dr. Horner is a wag;" "do ask him for some crop feathers: so bait your trap, and, my word for it, he will be caught." There *can* be no difficulty, as they are *unsold*.

I heartily concur with Dr. Horner in his opinion, that these are days of progress and improvement; and as I hope, ere long, to enter the field as a competitor, I with confidence await the time when "our fair appointments may be well perused," and sincerely believe that, unless the present breeders progress, and rapidly too, the true laced Polands are destined to drive the present *mongrels* (see Dixon) from the field, as the *laced* Bantams have the spangled, in spite of our friend's admiration for even the latter birds.—SCRUTATOR.

THE VICISSITUDE OF THE CLIMATE OF ENGLAND;

BEING AN EPITOME OF A WEATHER JOURNAL KEPT BY H. W. NEWMAN, ESQ., IN GLOUCESTERSHIRE.

HAVING kept a journal of the weather for many years, perhaps some account of the changes which take place may be of use to "Young England,"—I mean to those gardeners who have seen some twenty or twenty-five summers only.

I am old enough to remember the long winter of 1799-1800; this was distinguished by a long frost, and a heavy fall of snow, which lay on the ground nearly two months, and many sheep were lost in the north of Scotland. This winter was preceded by a very cold, wet summer; the harvest was damaged, and great scarcity prevailed. The winter of 1800-1 was mild; of 1801-2, severe; May, 1802, a very cold month; of 1803-4, mild; of 1805-6, very mild, and extremely wet and tempestuous. In 1806, a splendid summer; and the winter, 1806-7, mild. In 1807-8, a very severe frost, which continued for nearly two months; the turnpike-roads, at the end of January, for several days were a complete sheet of ice, and young men and boys were skating on them. During this frost one of those beautiful appearances on the trees, of frozen rain, took place; they were festooned with *rime* for a day, and there is no finer sight than some large elms covered with this rime. Such rime frosts seem to occur about once in every fifteen or eighteen years, during severe weather, and generally near the end of the frost; a correct drawing or painting of these sights in winter, so few and far between, would be most desirable. In 1809-10 there was severe frost; 1810-11, 1811-12, and 1812-13, were, generally speaking, mild winters. The summer of 1813 was wet, and then commenced the long winter of 1813-14. The frost commenced on the 26th of December, and on the 7th of January, 1814, snow fell for nearly three days consecutively, to the depth of six feet on level open ground, and drifted to the height of twenty feet in certain places. This frost continued (with an intermission of four days in February) for thirteen weeks. The Thames was frozen over for a long period, and a fair held upon it. The snow was not melted in the valleys in England until April. A fine summer followed. In 1814-15 was a mild winter, but in May, 1815, about the 15th, there was a severe frost; the gooseberries in many places were destroyed. In 1815-16 was rather an extraordinary winter; no frost occurred until the 10th of February, when a most severe one commenced. The Thames was frozen over for a week, and myriads of people were on the ice. It broke up suddenly, and a wretched

* *Coverlet*—The outermost of the bed clothes.—*Johnson*.

spring succeeded; there was a dry, cold May, and then one of the coldest and wettest summers followed, nearly similar to that of 1799. The harvest was not half got in; in Scotland the corn ripened only on the finest and warmest soils, and was damaged to a great extent.

The year 1817 brought another wet summer, but not so bad as did 1816. In 1818 we had a splendid summer; in 1819 a showery wet summer. In January and February, 1820, most severe frosts for a month or six weeks, and heavy falls of snow; 1820-21 and 1821-22 were very mild winters. In 1822 was the most plentiful harvest known for very many years. The winter of 1822-23 was very severe, and great falls of snow in February. Rather mild winters for two or three years followed; nothing material in the alternations of weather. 1826 had a dry spring, which was succeeded by one of the hottest summers I ever remember; in June and July the temperature was equal to that of Naples, viz., from 80° to 90° in the shade for six weeks.

In 1826-27 there was no frost until February, when the whole month was frosty. 1827 had a cloudy, calm summer, neither wet nor dry; the winter of 1827-28 was mild, and a fine spring followed. On the 18th of May, 1828, a thunderstorm occurred and broke up the weather. We had this year one of the wettest summers on record, but a high temperature; there were summer floods all over the low lands in the West of England, and a wretched harvest. It was followed by an early and severe winter; frost commenced the third week in November; and a great deal of frost in January, 1829. May and June, 1829, were very fine; but at the end of June the weather broke up, and a wet July and August followed. In the winter of 1829-30 we had severe frost. The end of this winter brought one of the greatest changes ever witnessed for half a century at least. The last three days of March were very warm; the thermometer being 64° and 66° in the shade; in the afternoon of the 31st the sky was overcast, and thunder came on, and then the wind shifted suddenly to the N.E., snow fell, and at daylight, on the 1st of April, the thermometer was at 24°—being a fall of 40° in fourteen hours. The snow remained for a week, from the 1st to the 8th of April. A wet summer followed this. 1830-31 and 1831-32 were mild winters and moderately warm summers.

The winters of 1833-4, and 1835-6, were very mild, with little frost. The summers of 1835 and 1836 were remarkably fine and hot, but not to excess. The winter of 1836-7 was very open, and one of the most remarkable seasons on record; there was no frost until the 10th March, 1837, the wind then shifted to the N.E., and continued to blow from that quarter for 10 weeks; severe frosts continued all through April, and on the 26th of this month the thermometer was 14 degrees below the freezing point. On the 16th of May it snowed nearly all day, and on the 17th great part of the day. There was no grass until the beginning of June, and the spring and summer came together, as in Canada. A tolerable summer followed this extraordinary spring, neither wet nor dry. 1838 brought nine weeks' frost, commencing the 7th January; this is known as "Murphy's year." A Mr. Murphy predicted in an Almanac that the 20th of January would be the coldest day. It was so; the thermometer falling to 30° below the freezing point! A very backward spring, followed with a cold May; a cool summer, and the winter mild. 1839 had a dry spring, and extremely dry May—a very wet summer followed, and wetness was the characteristic until March. 1840, had a moderate cool summer. In February 1841 there was about 10 days' severe frost, and a showery wet summer and harvest followed. 1841-2 was a very mild winter—the summer was a most splendid one. 1842-3 was a mild winter; May 1843 had twenty-five wet days out of thirty-one. 1843-4 was a mild winter; 1844 was one of the driest summers for 20 years or more, but the heat was not excessive. 1844-5 was a mild winter—nevertheless, in March 1845, there were 18 days of most severe frost, and a showery summer followed. 1845-6 was a mild winter, followed by a fine summer, with a fortnight of excessive heat in July. In January 1847, severe frosts; and on the 8th of February snow fell to the depth of 14 inches. The summer was fine. 1847-8 was a mild winter; 1848 a showery summer. 1848-9 a mild winter; 1849 a cool summer, but not wet. There was a bad frost in December, 1849, for 14 days; and also in January

and March, 1850. 1851-2 was a mild winter, and a fine summer; 1852-3,* a mild winter until the 7th of February, 1853, when came three weeks' severe frost.

"We should never halloo till we are out of the train;" for never do we know, in the British Isles, when winter is to commence—frequently not until March and April!

From the foregoing it will be seen that three winters frequently pass with little or no frost, but seldom four or five; that once in seven years, at least, we are visited with severe weather, and with very severe about once in fifteen years. There is little doubt that the extensive under-ground draining has a considerable effect on the coldness of our winters. It is observed in Canada, that the climate is not so severe in those districts which are drained, or cleared of the immense woods and forests.

Mr. Gilbert White, in his History of Selbourne, gives a programme of about twenty seasons, about the middle of last century. This is worth referring to by those who are curious in matters of the climate. He says, that severe winters generally are preceded by wet summers; and so it has been the case, with few exceptions, during the last forty years. I have noticed that most of the wet summers are preceded by "a dry month of May, with north-easterly winds." This was particularly the case in the wettest on record, 1802, 1816, and 1839. During the winter months, should severe weather be near, those sweet songsters, the thrushes, invariably cease singing.

POULTRY ON SHIPBOARD

IN No. 232 of THE COTTAGE GARDENER, under this title, your correspondent, "D. C.," complains of the great loss of poultry at sea; and, in a note attached, information on the subject is solicited. Having myself recently been applied to on the same subject, I think I cannot do better than describe the plan I adopted for the purpose of keeping a quantity of fowls on board ship in a healthy and, consequently, wholesome condition.

Being at sea one day, on board a yacht, in company with the owner, a gentleman farmer, the conversation turned upon the great loss of life amongst poultry when packed in coops and taken to sea. During the conversation, we approached the place where the coops were stowed, or rather crammed away. Upon one of the sailors poking up the birds, we discovered about one-third of the lot in such a sickly and diseased state, that the only way "to save their lives would be to kill them." This being done, the question was—How could the remainder be preserved? I suggested the following plan, and as it has been found to answer well, perhaps it may prove useful to others.

At the bows of the vessel a place was partitioned off, eleven feet long by three feet wide, and four-and-a-half feet deep; the back, top, and sides boarded, and made water-tight; the front covered with a piece of old fishing-net; the roosts fixed fourteen inches from the roof. This was all the room that could be spared, and was intended to hold twenty-five birds—rather close quarters, it must be confessed. The accommodation being completed, the next thing was how to manage the fowls. To the party in charge I gave the following directions:—When purchasing fowls, mind that they are young birds, and fresh from the farm-yards or runs, not birds that, perhaps, have been cooped up for a month in some cellar. Feed the birds on good sound barley—not oats, which are apt to scour them. Give every other day *sprouted* barley, which may be produced by placing the grain in a vessel, and damping it daily until it begins to grow; this, when green food cannot be procured, will be found a good substitute. In one corner of the enclosure, place a box (large enough for the birds to dust in) containing broken oyster-shells, old lime-rubbish, and small gravel; and in another corner a good supply of sweet, fresh water, and manage by placing a board partly over the vessel, that the birds do not make it filthy. The flooring should be washed out every morning, as nothing produces disease so much as a dirty, fetid atmosphere. Should any of the feathers

* 1852 will be long remembered for the great floods; rain commenced the 21st October, and were nearly daily until the 20th January.

under the vent of any of the birds get clogged up or matted together with dung, they should be carefully cut off with a pair of scissors. Should any of the birds show symptoms of illness, by the combs or wattles turning pale, such should be immediately killed. Vegetables at any time would be a treat, and prove highly conducive to the health and well-being of the stock.—M.

THE COTTAGE GARDENER'S PONY.

(Continued from page 446.)

I SHOULD recommend the cottage gardener to try a pony of one of the wild native breeds; say a little stout iron-grey, dun, or brown nag, of Scotch, Welch, or even Irish blood. But little care has been bestowed on the bringing-up of such animals; they possess a certain hardness of constitution indispensable where there is no convenient arrangement for ministering to the minutest details of stable mysteries. Which of us but has admired the hardy little car horse, when pleasantly posting from one place to another among the picturesque hills and valleys and waters of the North. The little animal is not, perhaps, very fast; his paces not the most regular; and his *tout ensemble* is anything but imposing; yet what loads he takes; what distances he travels! About home, too, our own butcher appears all but ubiquitous; whenever we ride out we meet him mounted on his Scotch pony; and he often passes us at a truly enviable pace. Or if we meet not the butcher, we meet his well-loaded cart, and behold the same pony quietly dodging from one house to another—the model of patience and endurance. Now, the whole of this class of horses contrive to get through a great deal of work, and with but a very moderate degree of care bestowed on their toilette; and they often last very many years. The fact is, their owners very seldom allow them to lose the instinctive faculty of taking care of themselves.

The pony should be of a cheerful temper, and tractable. A good animal physiognomist must judge of his moral character by looking at his ears, which should be set on wide apart, constantly in motion, but not inclined to lay back; by the eye, which should be bright, animated, not showing much of the white. The play of the nostrils and lips, and the very switch of the tail, convey a meaning. In fact, it is not the mere outward configuration of the parts; it is their motions, indicating the sort of spirit within, that we should attend to. But, besides the colour and cast of countenance of our new acquaintance, there are certain other points not so easy to explain;—as an ample chest; a short, thick carcass, well ribbed up to the haunch; a neck, if not very long, yet well set on; shoulders not too upright; clean, flat, deep, short legs, joined by well-knit, if not very lengthy pasterns, to hard, unbroken feet. Again—it is the action, as it is called, or the style in which the beast lifts his feet, and the fearless manner in which he puts them down upon the ground, like a Briton; it is his natural deportment, in a word, that must be our guide upon the whole.

The colour of the skin is not of so little importance as is implied by the proverb, which says—"A good horse is never of a bad colour." The functions of the skin are not half as well considered, either in man or beast, as they ought to be. The skin is at one and the same time a provision of defence against external agents, and a highly sensitive surface, or a means of receiving external impressions. A pachydermatous animal is simply a thick-skinned brute, a mere donkey, pig, or a rhinoceros. Conversely, to be thin-skinned, means to be superlatively sensitive nature and refined feelings. These are the extremes of the two functions which I have to attempt to distinguish. But even the hides of pigs, especially of the better families and blood, can be carried into a sort of fineness; and the ass and mule, in genial climates, and under partial masters, acquire higher susceptibilities, better natures, finer skins.

Domestication, also, in cold climates, along with the introduction of high-bred races, natives of the East, and artificial appliances for doing away with the necessity for trusting altogether to the powers of resistance of the skin, must impair those powers, at the same time that the other function or sensitiveness is greatly increased. Along with

this alteration in the skin (which it may take many generations to effect), the whole system seems to put on a new character, and the animal to acquire new susceptibilities, and to become, what we call, improved, or the breed becomes improved. This improveableness, probably, has its limits. Impaired powers of resistance to the alternations of heat and cold, wet and dry, feverishness, sickness, premature decay, coughs, and unsoundness; these evils, or if not these, at least an increased liability to them, are the price we pay for a high state of physical civilization—a highly artificial mode of life. It is just the highly artificial habit of life to which our very best horses are condemned, that necessitates all the over care that is taken to keep them "all right." Our rich bays, richer greys, light chestnuts, jet blacks, are, in general, fine-skinned; they require more clothing, grooming, and care, and will repay it better than the iron-grey, the dun or fallow, the brown or dark chesnut, which seem to take less harm under indifferent grooming, and seem to almost require a certain amount of exposure out-of-doors to keep them in health.

The pure native breeds of horses are but little subject to inborn unsoundness; should your "pony" be young, and should he exhibit no outward signs of previous ill usage, you may make your mind comparatively easy about ring-bones, spavins, splints, thorough pin, curb, windgalls, &c. These are neither more nor less than enlargements about the joints of the legs, or about the tendons, bony excrescences at or near the joints, or on the main bones between the joints. As a general rule, you should see that one joint is no bigger than the other, nor one leg enlarged where the other is not, nor graced by bumps or protuberances peculiar to itself. I have before me a fancy sketch of a horse, with every one of these blemishes on his legs duly marked with a number referring to an explanatory list; and the major part of them I have more intimately known on some one or other of the legs of some one or other of my own horses, or those of my particular friends.

I believe them to be oftenest hereditary in the high-blooded horse, though most easily acquired in the pony through a course of stable management uncongenial to his natural genius, and the habits of his race. You may easily make him unsound by driving or riding him too fast and too far; by denying him even the liberty of a loose box; by never turning him out to grass winter or summer; all which freaks you may play upon a blood horse with comparative impunity, if only, at a great price, you have procured a perfectly sound one to begin with. For one sound high-bred horse sold by the farmer for the London market, how many blemished and unlikely titts does he not rear? There are few lotteries where there are so many blanks; and, just to follow the fine horse in his London career, or in the stables of the land, everything is under artificial control—water, exercise, cooling mashes, stimulating cordials, hay, oats, warmth, air, his natural skin deprived of its hair, and protected by clothing, hoods for the head, bandages for the legs, his wind as anxiously looked to as the voice of an opera singer, and his skin cared for like the complexion of a fair lady. This system has undoubtedly brought some of our very best horses to an unrivalled perfection, but it all implies a thorough insight into certain stable mysteries, which very few grooms possess, though all confidently pretend to it—one result of which is, that many a horse which might last twelve or twenty years, with care, is often entirely spoilt in two. The reward of success is, that the animal can put forth his every power at once, and keep up a continued and sustained exertion for miles together, even when there is no sort of occasion for such trials. A dangerous accomplishment, I think, not worth half the trouble it costs; but if gentlemen will take their ideas about horses from grooms, and about their carriages from coach-builders, they will have to pay for it.—VIBGYOR.

(To be continued.)

SWEET CIDER MAKING.

As you have applied to me for the mode in which our Sweet Cider is produced, to the quality of which you have borne testimony, I have the greatest pleasure in acceding

to your wishes, and should any of your numerous readers derive any benefit from the same, it will be a gratification to me to know that the information I have given has been of any benefit to them.

Most of the Sweet Cider you meet with, especially that which is bottled, has its sweetness preserved by some chemical process it undergoes as soon as taken from the press. A system called "matching" is also much used, to suppress the fermentation; but such systems I do not recommend, for the Cider gets so much impregnated with the drugs that are used, that any person who is in the habit of drinking pure, unadulterated Cider, can easily detect it. I should say it is also highly injurious if taken in any large quantity; in fact, I have known people suffer from taking a second glass. There are many men who derive their principal income from their Cider crop, and, of course, use means to make as much as possible of the best quality, with the least trouble and expense, knowing that if they can only keep it sweet it will be purchased readily in the large towns. The producer of such Cider will argue that it does not affect the liquor; but I leave the reader to judge whether such powerful means as are required to check at once the fermentation must not impregnate the drink.

Now for the mode which we adopt in making sound Sweet Cider. It is certainly attended with much more trouble and labour, and some say waste, but in that I do not agree, if it be managed with care; for all the dregs which are taken from the bottom of the cask each time of racking are put back into a barrel set apart on purpose, and which, in a short time, if the weather is clear, will again separate. It is then again racked, and makes good strong Cider for general purposes. Disappointment will sometimes occur from neglect, but, if strictly watched, you will be amply repaid by possessing such a pure, wholesome beverage, that I have known it to be taken in preference to the best wine.

To make such Cider we take the best fruit, or I would say the apples from a certain orchard, which being mostly good sorts we never separate them, as it requires a mixture of sour and bitter with the sweet to make the best quality. There should be about two-thirds of the latter to one-third of the sour and bitter. We allow the apples in that orchard to remain till nearly the last gathering, unless frost sets in, which is highly injurious. Care should be taken never to put them together in frosty weather, as it is very detrimental to the quality, which becomes pale and thin, and will not keep good any length of time. There is a rule which should generally be the guide, and that is, that when the apples will easily fall by shaking the tree they are in the best stage for gathering. We then take them to the apple loft till sufficiently matured for grinding, which will take place, according to the mildness of the season, in about a fortnight. You will perceive that some of them will turn quite black, but care must be taken to have these picked out. They can be thrown back with the rougher apples, and used in the general way.

As soon as the apples are ground, the pulp is placed on the bed of the press, in alternate layers with fine clean wheat straw, in the afternoon, and remains in that state till the next morning, to enable the liquor to retain as much as possible the flavour of the pips and rind. The juice is then pressed out as fast as possible, and at once removed to the fermenting vat (a barrel with the head taken out answers the purpose). This vat is filled nearly full, and the juice remains there till the first or vinous fermentation has taken place, which occurs, generally, on the second day; but if the weather is cold it may remain much longer. It is easily perceived by the white froth or scum with which the whole surface is covered. The outside will become more creamy, and as soon as you perceive it turn brown, the cider must be immediately drawn off and put into the cask. You must be particular not to mix any of the scum or pickings at the bottom; to avoid which have a cork hole at the bottom of the vat to place your tap in, from which you draw off the liquor, instead of dipping into it. The greatest vigilance is now necessary. An empty cask must be kept ready to rack the Cider into as soon as required, as now the object is to prevent the acetous fermentation taking place, and thus preserve the sweetness. This fermentation is discovered by applying the ear several times a day to the bung-hole (the bung being loosely placed on), to note if a singing noise, which

accompanies incipient fermentation, be audible. This noise is a kind of hissing occasioned by the extrication of small bubbles of carbonic acid gas, which, as the action increases, break forth in a torrent, accompanied with a formation of froth on the surface of the liquor. A very short continuance of this is destructive of much sweetness in the Cider. Care must, therefore, be taken, on the very first symptoms of fermentation, instantly to rack the Cider into the other cask. Place the dregs into the barrel set apart, and wash your cask clean for the next racking, which must be repeated as often as these symptoms shew themselves, which will probably occur in twenty-four hours, more or less, according to the state of the atmosphere. In fine cold weather the rackings are less frequent, and sometimes six or seven may suffice; whilst, in mild foggy weather, I have known two rackings required in twenty-four hours; and as many as twenty before the fermentation is subdued. A small cask should be managed at the same time, in order, at the last racking, to be able to fill up the larger one near enough to the top so as just to be able to touch it with your finger. Then bung it down tightly, and in the month of March take advantage of the first few clear days to give it another racking. Bung it again tightly, and paste over the bung, so as to render it perfectly air-tight, and you will find it keep good and retain its sweetness for many years.

I would observe, that the soil has much to do with the quality of the Cider; that from a clay subsoil far surpassing that from a light sand.—T. P., *South Petherton, Somerset.*

DISEASES OF POULTRY.

EGG-BOUND.

The following appearances were observed upon the examination of a Shanghae pullet the day following her decease:—

Body somewhat emaciated; skin much discoloured, as if jaundiced, emitting a rancid unsavoury odour.

Upon opening the abdominal cavity, the whole of the peritoneum presented a highly vascular and inflamed condition, especially about the cloaca and ovaries. The intestines were glued together by recently effused lymph, whilst flakes and patches of the same material were found in various parts of the cavity. Lying over the right kidney was a mass of putty-like matter, which bore some resemblance to the yoke of an egg, though somewhat changed in character. The oviduct being next laid open, exhibited much inflammation towards its termination, whilst in the calcifying segment was the crushed shell of an egg, from which the yoke had apparently escaped; the membranes being otherwise perfect. Kidneys, lungs, and other organs healthy.

Hence it would appear, that death, in this instance, resulted from peritonitis, produced by the irritation set up in the oviduct by the retention of a crushed egg in that canal, and by the escape of its contents backwards into the peritoneal cavity—a very unusual circumstance, probably, but, nevertheless, in this case, I think unquestionable.

The prevalent system of over-feeding and over-stimulating poultry, doubtless, contributes largely towards the production of all manner of inflammatory complaints. Had an antiplogistic and unstimulating course been pursued with this pullet as soon as any symptoms of irritation or inflammation of oviduct were apparent, she might now, possibly, have been the mother of a large, thriving, and valuable family of "lovely Cochin-Chinas."—FRED. J. BUTLER.

EXHIBITION FEVER.

In your paper of February 24th, "W. A. E." states that his "fowls" are attacked by the "exhibition fever." Now, as I had nearly twenty attacked in the same way about twelve months since, and did not lose a *single bird*, I venture to inform you in what way I treated them. Immediately the first symptoms appeared (which was exactly as "W. A. E." describes, viz., very loud breathing, accompanied at intervals by a husky cough, the head swollen, and the eyes closed), I gave the bird about one table-spoonful of "oil," and confined it in a coop, placed in a dry house,

feeding it twice a day with pills (about the size of those used for cramming fowls) composed of meal mixed with ale, taking care to supply it with plenty of *fresh* water, as although blind they are still able to find the dish containing the water.

I found that most of the birds were "blind" from two to four days, and after that time gradually recovered. Is not this disease very similar to the "roup?"

In regard to the query—"Which variety of fowls *eat the most?*"—although I have never kept any accurate account, I am still *decidedly* inclined to think, that of the seven varieties which I keep, the "Malays" are the largest consumers, closely followed by the "Cochins."—WILLIAM POPE, *Symonsbury*.

LADY-GARDENERS.

In these days, when the country swarms with editors of gardening publications and their co-adjutors, all dictators of taste in their line, how is it, Mr. Editor, that there are in every neighbourhood so many rubbish-plots, falsely called gardens, adjoining gentlemen's houses? I think, Mr. Editor, you are not without blame in this matter; you mystify the public so, that no one rightly knows where to fix the disgrace of slovenly gardens. You tell us at one time "the garden is too large for the strength kept;" at another, "the gardener is an incapable." Now, you have added to your title "The Country Gentleman's Companion;" why not have done yourself and the public a service by adding instead "The Country Gentlewoman's Companion," and kept the title in your mind? I am very fond of gardens; I stick at no trouble if I can visit them; and wherever I have seen a garden remarkable for beauty, I have always found the mistress of the place took an active delight in its superintendance; and let wives but find intellect to direct, and where is the husband will grudge paying for labour properly applied? I am sure clever gardeners will chime in with me in the above recommendation, as their abilities can only be appreciated by knowing ones. Your able co-adjutor, Mr. Beaton, a master in his profession, I know will bear me out, for he speaks gallantly of the assistance and encouragement he received of his mistress, and from ladies in general. Now, if gentlewomen who can afford to have men of Mr. Beaton's stamp, with a whole staff of subordinates to superintend their gardening operations, neglect not to give their time and attention to details, what can be said for those ladies who can afford but one or two ordinary gardeners, and require a proper day's manual labour out of them? Is it to their praise if they exercise their mental powers on crochet-work or knitting, which any child of three years old may rival them at, while their gardens are being managed with the most wretched taste? Who can blame the gardeners under such circumstances? A modern author says, "the smell of the earth has in no country a favourable effect on the development of mind." Now, this is so far true, that the afore-mentioned gardeners, who would cultivate their minds, must work by night as well as day, and I am proud to say many do so; but employers have no right to expect, in a general way, to reap the benefit of such cultivation. When Fox and Henderson undertook to build the Crystal Palace, or any other of their great public works, they knew they must employ the common labour in the market, and expected to be shown no favour on that account. The wives of England have contracted to make the homes of their husbands earthly paradises; let them take a pattern from Fox and Henderson, and make the best possible use of the materials at hand; by so doing they may feel assured of finding their full modicum of contentment, health, wealth, and unfeigned approbation.—Y.

POLAND *versus* HAMBURGH.

I AM perfectly aware that all the varieties of the Chitteprats, Boltions, and Dutch fowls, have lately been classed together, under the title of Hamburg fowls. I believe the Rev. E. S. Dixon first promulgated this classification, and that it has been since followed at most of the leading poultry shows. It is not the classification that I object to,

which I consider good, but merely the adoption of the name Hamburg, that did properly belong to a tufted variety of fowl. I think it would have been much better to have classed them together under one of their own names, of which there is a great variety, instead of depriving the Hamburgs of the only one by which they were known.

That the real Polands are distinct from the Hamburgs (also a variety with large tufts), I will show by a side-by-side description of each, and had the Rev. E. S. Dixon been acquainted with their distinctness, he never would have described the Hamburgs as Poles (for those he has described in his work are certainly not Polands), nor would he, with such a knowledge, have applied this name to the tuftless varieties; nor do I suppose he would have mistaken the colour of a true spangle.

I can assure all those interested in the poultry fancy, that the two varieties did exist not many years back, but as the Poles became scarce, the Hamburgs, of German extraction, usurped their place, and in the course of time the true properties of the Polands seem to have been forgotten, and the Hamburgs generally received as such, which error I wish to point out.

POLAND.

A large fowl, the cock of good courage, hens non-sitters, chickens tolerably hardy.

No comb, not even a single spike, top-knot very large and full, spreading out on all sides, and falling over the eyes, so that the fanciers found it necessary to tie up or clip away some of the feathers that the bird might see better.

Body glossy-black, changing to purple and green; top-knot quite white.

Colour of the Spangled Polands rich ochre-red, lined or grizzled with black, and each feather tipped with a *white* spangle at the extremity.

Top-knots white.

White Polands, body clear white.

Top-knots black.

These last are generally considered extinct, but it is forgotten that the true Polands, through all their varieties, are likewise going.

Both varieties are occasionally muffled, or bearded, but the Hamburgs more generally so. It will be seen by these descriptions what is necessary to constitute a true Poland fowl, and, on inspection, I think it will be found that nearly all the birds at the present time known by that name have, more or less, relationship with the Hamburgs. The Rev. E. S. Dixon, in his praiseworthy attempt to clear up the (to the uninitiated) confusion respecting the Dutch, *alias* Bolton, *alias* Chitteprats, has caused a greater confusion between the true Poles and their cousins-german the Hamburg fowls. These varieties are frequently imported direct from Hamburg, which name they have enjoyed these thirty years—quite sufficient to prove their claim. It is also true that a few of the Dutch pencilled fowls are sometimes brought from Hamburg, and thus by some have been considered as Hamburgs; but this is not a sufficient reason that the whole family of Dutch, Bolton, Chitteprats, &c., should appropriate the name to their own use, and to which they have only aspired during the last few years.

It is not my wish, however, to enter into a Chancery suit as to whether the Hamburgs are to gain possession of their name; all I wish is, that the properties of the true

HAMBURGH.

A medium-sized fowl; the cock a great coward; the hens generally sit; chicken tender.

Comb small, generally double, terminating in two spikes or horns, and fronting a good-sized tuft, which flows backwards, leaving the eyes exposed.

Body black, frequently grizzled, with gold or silver; tuft white, faced with black, and sometimes nearly all black.

Colour of Pheasanted-Hamburg, ochre-red, each feather having a black spot at the extremity, the marking often irregular. Cocks frequently dark about the thighs.

Tufts almost always dark. Laced-Hamburgs were of two varieties, gold and silver, the feathers were clear of other colour, having a narrow margin of black.

Tuft also dark.

old Polands may be generally known, and not forgotten; and that, should they be recovered, the contaminating associations with the Tufted Hamburg may be guarded against, which, however, I should have no particular objection to receive as Poles, provided they appear in full dress without combs.—B. P. BRENT, *Bessels Green, Sevenoaks.*

[Mr. Brent has kindly sent us the above paper on the Polish and "tufted Hamburg" question. Could a combless, perfectly white-crested Polish fowl, as there described, be referred to as a living specimen, the question would be much narrowed; but hitherto we have not been so fortunate as to meet with it; and indeed Mr. Brent himself would lead us to infer that it has become extremely rare. His description of the Hamburg's tuft falling back on the neck exactly coincides with what we now see in the male birds of what are now called Polands, with whom the hens constantly display a perfectly spherical top-knot, in shape such as Mr. Brent would regard as the property of his old Polish only.]

The classification now in use has the great merit of simplicity, and we must own our inability to foresee any advantage likely to result from its discontinuance. "*The tufted Hamburg*," we fear, will fail to support his case, as of distinct origin and lineage from his Polish neighbour.

Again, the Gold and Silver Hamburgs, both pencilled and spangled, have so many points in common with each other, that we should greatly regret any system of nomenclature by which we should hazard their disunion, and this would probably happen were we to single out the Silver-pencilled birds as "Dutch Every-day-layers," or apply the appellation of Grey Boltons to the Gold Spangled variety.—W.]

TO CORRESPONDENTS.

. We request that no one will write to the departmental writers of THE COTTAGE GARDENER. It gives them unjustifiable trouble and expense. All communications should be addressed "To the Editor of the Cottage Gardener, 2, Amen Corner, Paternoster Row, London."

HANDBILLS INSERTED IN THE COTTAGE GARDENER (*Clericus*).—We assure you positively that the highly objectionable Handbill you sent to us was not inserted by our Publisher. Mr. Dickens complained in *The Times* of similar Handbills being inserted in his "Household Words." They are inserted by some low agent in London, connected with those your Bookseller employs.

WARD'S CASE (*Fernatum*).—You ask what ferns and mosses are suited to a Wardian case 4½ feet long, 3 feet wide, and 3 feet high, with bars across for Epiphytes in boxes on blocks. You grow *Cypripedium speciosum* well in it, and in a close case have grown well, *Trichomanes speciosa* and *Hymenophyllum Wilsoni*. We gladly accept your offer of telling us how you manage the two last so well, as they are rather difficult, especially the *Trichomanes*, no one having done much with it without a close moist atmosphere, just like what your close case would supply. With such success we feel doubtful if we are able to give many advices respecting the Ward's case. We should have known better if you had told us the construction, and whether you can give it any heat in winter besides throwing a cover over it. If not, then we would add *Cypripedium calceolus* and *pubescens*, and *Orchis longicornu* and others. To the two ferns named above, we would add *Asplenium fontanum*, *Asplenium adiantum nigrum*, and *Asplenium trichomanes*, *Cetrarch officinarum*, *Adiantum Capillus veneris*; and for mosses, select *Lycopodium apodum*, *denticulatum*, and *helveticum*, the first being very low and compact. If, by means of a drawer beneath, lined with lead or zinc, you could apply heat by warm water in winter, then, in addition to small patches of the above, you might have *Gymnogramma sulphurea*, and *Adiantum formosum*, for the centre; *Adiantum pubescens*, and *rhomboideum*, and *cuneatum* for a lower level; in line with *Lycopodium Willdenovii* and *stoloniferum*; while the rods might be supplied with little baskets of *Lycopodium violaceum*, and *Brazilense*, which would have a fine appearance hanging down. A few plants of *Eschynanthus parasiticus* and *ramosissimus* may be suspended in a similar manner; but though they will grow well with but little air, they must have fresh air to get them to bloom freely. The subject will, ere long, receive more definite attention; but these hints may meet the present case, and keep a correspondent from waiting, which we never like to do.

FROST-BITTEN FOWLS.—An *Old Subscriber* says:—"During the late frost I have had two valuable Dorking birds frost-bitten, and both of them are since dead; they lingered some time, and gradually wasted away." [It would tend to more satisfactory results if correspondents would describe the symptoms of their diseased birds as closely as possible. In this case it is not stated in what manner the frost affected them; the cold might have produced mortification of the comb, which happens when it is frost-bitten, or the legs might have been similarly affected, or some internal inflammation may have resulted from the exposure; each of these cases would require different treatment. I can only answer the enquiry generally, by stating that in all cases of frost-

bite, or numbness from cold, the most certain mode of producing a fatal result is to expose the patient suddenly to an increased temperature. If the comb is frozen, thawing it by the fire, or in a warm room, is certain to produce mortification; the same with the legs and feet. The proper treatment is to rub the parts with snow, or a cold wet flannel until the circulation is restored; should the whole body be benumbed, the natural warmth may be attempted to be regained by covering the bird up with flannel or hay, and bringing it by the slowest possible degrees into a warmer air; suddenly bringing a frozen bird into a hot room is almost certain to prove fatal.—W. B. TRGETMEIER, *Tottenham, Middlesex.*]

GARDEN PLANS (*Clericus* and *M. E. G.*).—We can only repeat our inability to plant or lay out beds on paper for places we have never seen. The garden of *Clericus* is very tastefully laid out, and particularly the corner figures, where ninety-nine out of a hundred incur failure. *M. E. G.* would require a first-rate artist on the spot to do justice to his beautiful slopes towards the river.

SCREEN OF EVERGREENS (*Quercus*).—There are no plants better for making a screen across a garden than *Laurels*, but as your's are to be on a mound, you might add a few plants of *Arbutus* and *Alaternus* along the top of the ridge, and keep them ten or twelve feet apart, and laurels a yard high. Plant four feet apart every way, and that is the easiest way to find how many plants you need. Your mound is all right, but all the plants ought to be in before now. Of all the follies and extravagancies in gardening, none exceed that of planting trees or shrubs, evergreen or otherwise, late in the spring. You would gain one season in four if you were to put off this planting till next October, that is, in four years plants put in next October will be one year in advance of others of the same kinds put in this April—an axiom as true as any in Euclid.

BEES—EXCESS OF DRONES (*A Country Rector*).—"Can any apiarian kindly inform me why drones eggs were laid in two hives last spring instead of workers. The drones first showed themselves in April, but the hives decreased in strength, and dwindled on till autumn. Perhaps the information in fumigating bees, which I have gained by experiments, may be useful to others, as at first I found great difficulty in clearing the hive of all the bees. I now fumigate the hive twice, removing all the bees I can obtain by the first process, for the purpose of uniting with other hives, and then leaving the bees that adhere to the comb three or four hours before the second dose, when the hive will be left without a bee adhering to the comb; the queen usually being with the last lot. Experience has told me that very large hives are a mistake; for if the royal cells, after swarming, are situated low down in the hive, the population left do not generate sufficient warmth to hatch the grub." (The drones which appeared in your hives in April, were in all probability not killed in the preceding autumn, on account of the death of the queen at a time when there were neither eggs nor brood in the hive from which another queen could be made. We had an exactly similar occurrence ourselves two years ago. The drones, in this case, made their appearance the last week in March, but the stock, although then very strong, both in bees and honey, dwindled away till autumn, and then died.—J. H. P.)

CROWING HEN.—"If I might be allowed to give an opinion, I should strongly recommend '*Chicken-hearted*' not to be so in regard to the 'Crowing-hen' of which he or she complains, but to make away with 'him,' 'her,' or 'it,' as soon as may be, for I am sure it never did lay, and never will. It is an '*hermaphrodite*,' and besides plaguing all the hens, will very often be inclined to eat the eggs, and to teach others to do so too. I have seen several instances of this. The only cure is 'death,' and the speedier the better.—K."

ANNUALS SOWN IN TURF (*Bengal*).—It is an excellent plan, and not the worse for being nearly forty years old, and for which the Caledonian Horticultural Society gave one of its best prizes. The plan is fully explained in a former volume; but being now just in season, here it is again—peas, beans, and all, or almost all kinds of garden seeds might be sown in the same way. Take turf one inch or an half-an-inch in thickness, and with a spade or old knife cut it into ribbons two inches wide for drill-sowing; lay the ribbons at full length, and close to each other, with the green side downwards, under a cold frame, or in a very sheltered place without a frame; sprinkle some light soil all over the mass, filling in the hollows between the edges of the ribbons; then sow the seeds, one row along the centre of each strip of turf; when the seeds are well up, and time is to transplant them, run an old knife down between the ribbons to separate any roots, then, with a gentle move, raise each piece and lay it on a flat board or barrow, and plant it in a little trench, so that the seedlings are half-an-inch deeper this time. For planting in patches, cut the turf to the size of the patch, it will do square or round; these pieces or strips of turf are better than pots for many things, and finally they decay, and furnish a supply of fresh soil to the roots; the thickness, the lengths, or the sizes, are all matters of convenience, and any form or size, or thickness, is as good as another, if it suits the particular case.

PRELARGONIUMS (*Kathleen*).—You have: 1, Cyrus; 2, Curtis' New Comet; 3, Garland; 4, Lady Rivers; 5, Magog; 6, Sylph; 7, Stautiskil; 8, Emma; 9, Incomparable; 10, Negress; 11, Scedling; 12, Duchess of Sutherland; 13, Druid; 14, Ivanhoe; 15, Lilac Unique; 16, Peel; 17, Othello; 18, Hebe's Lip; 19, Regulator; 20, Orion; 21, Sun Rise; 22, Forget-me-not; 23, Nonpariel; 24, Albion; 25, Pluto; 26, Priory Queen; 27, Queen; 28, Milliflora. The following are the best kinds in your list, but wait to see which you prefer. 1, 5, 6, 10, 17, 18, 19, 20, 21, 24, fine, 25, and 26. The following are fancies—4 not quite so good as *Queen Victoria*, but like it; 7, an ugly black sort; 24, very fine. You see it among the best at the last summer exhibition; 15 is a bedder, and rather new; 26 the best bedder of all this strain.

IVY AGAINST A WOODEN FENCE (*Ibid.*).—We have heard and read of many arguments for and against the plan, but we never give a decided answer to a question we do not ourselves know to be right. Therefore, we propose this question to all our readers—Do you happen to know a wooden fence, tarred or untarred, against which Ivy has been growing more than fifteen years? If so, what is the effect on the wood, as com-

pared with another fence of the same kind, but not covered? Also, what is the oldest wooden fence you know that is covered with Ivy, or with tar, or with both, or not covered at all with any paint or plant?

KEEPING BREEDS DISTINCT (Fiat).—There is no plan by which poultry of various breeds can be kept distinct if allowed to run together; and no previous acquaintance would avoid subsequent general intercourse. As to "poultry thriving in captivity," that depends on the extent and arrangement of their yards, as also on their management. If a run on alternate days is permitted them, they will do well; but if constantly confined, their enclosures should be large, containing both grass and gravel, otherwise we doubt their being profitably kept. We never ate a really good *Musk Duck*; their flavour and flesh are both coarse. *Chinese Geese* have long been domesticated; their average weight is from ten to twelve pounds. **THE POULTRY BOOK**, of which the first number will be published by Messrs. Orr, of Paternoster Row, on the 31st instant, will, we trust, meet your requirements.—W.

WHITE BANTAMS (A Beginner).—A white Bantam we should wish to see with white legs; but the mere fact of its having blue legs would not be sufficient to constitute a *distinct breed*.—W.

PROFITS OF POULTRY-KEEPING (C. L. T.).—Your statements are all theoretical. Great extent will be required to keep a head of 140 breeding-stock, comprising, as you suggest, so large a proportion of turkeys and geese. Without constant change for these, and their supposed progeny, 1800 in number, the ground would soon become tainted, and disease of every kind would probably ensue, so that your present sanguine calculations would be sadly disappointed. We say nothing of the difficulty of keeping five males of each variety, without various casualties from their mutual jealousies and conflicting interests; nor do you seem to be aware of the number of bad eggs resulting from the access of more than one male to the hen, and that the *quality*, no less than the *quantity*, of the stock so produced suffers great deterioration; hence our constant advice to farmers to select, yearly, their best five or six hens, and place them with a fresh cock, apart from the other poultry, and hatch from them alone. When more eggs are required for this purpose than these would supply, another lot should be set aside in the same way, and we have no doubt but that the result would be sufficiently satisfactory, even in the first year, to ensure the continuance of the practice. We must question the accuracy of your premises when you state, that a quarter-of-a-pint of hard corn will afford "good feeding" to your flock collectively; for a full-grown hen would certainly not be in danger of repletion from such an allowance, and we are quite sure that turkeys and geese could not be kept on it with any chance of profit. "Food procured abroad" must of course be limited to worms, insects, and any wild fruit or berries that may fall in their way; but any run of a rickyard, or incursions into neighbouring corn-fields, at once invalidates your calculations. We doubt, again, the arrival at maturity of 450 young birds from each division of thirty hens, geese, turkeys, and ducks; nor have you borne in mind the chance of losses in your old birds before, or during, the breeding season, so that, to make up your full number of 450, you would require each mother to bring to maturity at least seventeen or eighteen young ones every season—success, we fear, hardly to be attained with thirty hen turkeys or geese! Your prices, too, have a greater leaning to the retail than the wholesale average; and you must excuse us if we doubt the fact of your obtaining 5s. per couple for fowls whose dietary throughout life has not exceeded 1s. each. The same observations apply to your other items; goslings, for instance, that are to realize 6s. each, are scarcely to be reared for 1s., so that the profit should be (as you place it) no less than 5s. per bird. You reckon £200 as the probable amount of capital expended in buildings: we do not understand how your numbers can be accommodated for this sum. A labourer at £20 a-year cannot mean an able-bodied one, and we much question whether even an able-bodied one would be sufficient; besides, there are many offices connected with poultry in which the henwife becomes almost essential. We see no estimate for *rent* of land, but at least ten acres of grass would be required for the run of your stock. Your average of eggs, at 1s. per dozen, is far too high for England generally. If we differ so entirely from your too sanguine anticipations of the profits to be realized by poultry-keeping, our motives should be well understood, and we have here given free expression to some of those reasons which have now led us to express opinions so diametrically opposite to your own. We say *some*, for your line of reasoning is open to other objections beyond those we have alluded to in this notice. But it strikes us that one cause of your arrival at these incorrect conclusions may be thus accounted for:—The most favourable balance-sheet of poultry-keeping will usually be found to refer to a very limited number of birds, some half-dozen hens, perhaps, and a cock, enjoying, probably, many advantages in irregular additions to their bill of fare, and probably, too, sharing a portion of their owner's dwelling-house. Food actually purchased for such birds may be within the sum you mention, but the moment you proceed to reason from these circumstances to the gigantic poultry-yard referred to in your estimate, your argument fails. We are the more inclined to this opinion from your line of allusion to your *having kept poultry some years ago*, and, apparently, not on a scale anyways approaching towards that on which your present calculations are based. At a time when, as you justly observe, such "general attention has been drawn to that wide field of emulation, the successful management of domestic poultry," it becomes the stern duty of any periodical professing to treat on that subject, to discourage whatever may appear to encourage great expectations of profit, when the reasoning on which it is formed may appear defective; you will, therefore, pardon this explicit declaration of our opinion, however at variance with your own.—W.

PRIZE FOR GARDEN PLANS (T. H. W.).—You will find the particulars at page 379 of our Number 229, published on the 17th of last month.

PROTECTING MATERIAL (A. M.).—Either of the specimens of canvas you forwarded to us would answer well for sheltering fruit-trees; but thirteen or fifteen pence per yard would be an objection.

GREENHOUSE CLIMBERS (J. Kirkite).—You will find a list, with colours of their flowers, at page 72 of our No. 213.

GREEN WATTLE (W. H. C.).—We cannot tell you where you can obtain either seeds or cuttings. *The Horticultural and Pomological Association* would hunt it out for you, if you were a member.

GRAFTING AZALEA INDICA (1001).—We cannot write private letters on such subjects. Read the paragraph again, it is clear enough, and you entirely misquote it in your letter.

SILK WORMS' EGGS.—T. K. A. wishes to know where these can be obtained.

HYBRIDS BETWEEN THE PHEASANT AND FOWL.—We have instances from G. D., and a dozen others. The fact we considered established.

TWO EGGS PER DAY (A. Horncastle).—This is not uncommon with a Shanghai hen; nor is it a novelty for one egg to be found within another.

BOOK ON POULTRY (J. S. Robinson).—No work hitherto published contains so much information relative to Shanghai fowls as will *The Poultry Book*, which will commence publishing on the 31st instant. If you require a cheap manual for immediate use, buy Richardson's "The Domestic Fowl."

SOFT EGGS (J. F., Reigate).—We think that you feed the fowls too well. Give them food less in quantity and less fattening. We are confirmed in our opinion by the fact, that when you send your hens elsewhere they cease to lay soft eggs.

SHANGHAI COCKEREL (J. M.).—You fear he is dying, and ask advice, but do not mention a single symptom. Editors do not possess *clairvoyance*.

COUVE TRONCHUDA—CYPRIPIEDUM SOIL (W. H. Turner).—The leaves and stalks are the parts of *Couve Tronchuda* that are cooked. These are peeled and then cooked like Sea Kale. For the soil for *Cypripedium* procure some sandy peat, leaf mould half rotten, and turfy loam, mix these together without sifting, and this compost will grow them well. They are found in hot swamps, hence they should have plenty of water during summer, but more moderately in winter. They should never go to rest, like the *epiphytal orchids*.

SPANISH FOWLS (T. F.).—A pure-bred Spanish fowl is required to have the white face and ear-lobe so characteristic of its race, while the plumage should be entirely of a glossy black. This we regard as the true type and best form of the Spanish bird; but they are often imported from Spain, and elsewhere, of every possible degree of mongrelism, and deviation from the present standard of excellence. *Pip* is distinct from *roup*.—W.

LYCOPODS (A Constant Reader).—Mr. Appleby will give the remainder of the paper on *Lycopods* shortly. We will inquire about *Moore's labels for Ferns*, and let you know where they are to be procured.

PANSY GROWER (F. L.).—The address is, Mr. Thomson, Florist, Iver, Bucks.

GRAFTS FOR EXCHANGE.—A. B., 7, Charles-street, St. James, has a few grafts of the best apples and pears which he wishes to exchange for good hardy herbaceous plants. Your query will be answered next week.

AZALEAS (A. G.).—No one from such specimens can tell their names. The varieties are numerous, and the distinctions slight.

LIQUID MANURE FOR TURNIPS (A Subscriber from 1st Number).—An article upon the subject of manuring for turnips will appear shortly, in which the subject of liquid applications will be alluded to in detail; and particularly as relates to the use of pigeon and fowl's dung.—J. B.

THRASHING FLAX (J. S. B.).—To thrash flax, use an ordinary flail with a larger and shorter swingle-stick than is used for thrashing wheat and other grain; lay the flax thickly on a smooth wood floor, and turn the haulm often until all the seed be removed, then tie the stalks into small bundles. In this way the fibre will not be damaged.—J. B.

ENTRANCE TO TAYLOR'S HIVE (H. Hood).—We have had a set of Taylor's shallow bee hives in use for the last two summers, and no inconvenience whatever has arisen from the entrance being in the centre, indeed the box is so broad that the bees can escape any draft from the entrance. The plan proposed of a double floor-board is objectionable, first, affording an imperfect ventilation, and next making it very difficult for the bees to bring out dead and imperfectly formed brood, sufficient sometimes to endanger the health, and even life of the stock. You must have put too much water to your sugar; one quarter of a pint to one pound of sugar, and one teaspoonful of vinegar; twenty minutes' boiling makes it crisp.—P.

LONDON: Printed by HARRY WOOLDRIDGE, Winchester High-street, in the Parish of Saint Mary Kalendar; and Published by WILLIAM SOMERVILLE ORR, at the Office, No. 2, Amen Corner, in the Parish of Christ Church, City of London.—March 24th, 1853.

WEEKLY CALENDAR.

M D	W D	MARCH 31—APRIL 6, 1853.	WEATHER NEAR LONDON IN 1852.				Sun Rises.	Sun Sets.	Moon R. & S.	Moon's Age.	Clock bf. Sun.	Day of Year.
			Barometer.	Thermo.	Wind.	Rain in In.						
31	Th	Curve-dotted; hedges.	29.852—29.500	48—39	N.E.	—	39 a. 5	29 a. 6	1 45	☾	4 14	90
1	F	Speckled Wood; wood sides.	30.203—30.015	51—24	N.E.	—	37	31	2 m 48	23	3 55	91
2	S	Common Copper; commons.	30.303—30.270	52—25	N.E.	—	35	32	3 37	24	3 37	92
3	SUN	1st. or Low SUNDAY.	30.326—30.246	51—29	E.	—	33	34	4 14	25	3 19	93
4	M	Water Betony; gardens.	30.156—30.147	50—30	S.E.	—	30	36	4 41	26	3 1	94
5	Tu	Dark drab; oaks and fallows.	30.146—30.099	58—28	N.E.	—	28	38	5 3	27	2 44	95
6	W	Twin-spotted Drab; oaks.	30.146—30.111	57—39	N.E.	—	26	39	5 21	28	2 26	96

METEOLOGY OF THE WEEK.—At Chiswick, from observations during the last twenty-six years, the average highest and lowest temperatures of these days are 55.7°, and 36° respectively. The greatest heat, 78°, occurred on the 3rd in 1848; and the lowest cold, 16°, on the 1st in 1838. During the period 105 days were fine, and on 77 rain fell.

CALISAYAN BARK SHRUB
(*Cinchona Calisaya.*)



THE fact of this being the plant which yields the Peruvian Bark, so long celebrated as a potent medicine in our contests against Ague and other intermittent fevers, would, of itself, justify our devoting rather more than our usual space to its consideration.

It is that plant of which Darwin says

“Where Andes hides his cloud-wreathed crest in snow,
And roots his base on burning sands below;
Cinchona, fairest of Peruvian maids,
To health's bright goddess in the breezy glades
On Quito's temperate plain an altar rear'd,
Trill'd the loud hymn, the solemn prayer prefer'd.”

The object of the prayer was a remedy with which to be armed when

“Fierce from his fens the giant *Ague* springs
And wrapt in fogs descends on vampire wings.”

The request was granted, and the plant affording the specific is that now before us.

There are various specimens of *Cinchona* which yield the Bark so well known in medicine; but Dr. Weddell, in his *Natural History of the Quinquinas*, states, from actual and long research in their native country, that this produces “the most precious of the Jesuit's Barks used in medicine.” He found it only in Peru and in the southern part of the province of Carabaya, and nowhere beyond Campolican, or Apolobamba, the place of its first discovery, that is, between 13° and 16° 30' south latitude. The Bolivian Company export annually more than 4000 quintals of its bark, each quintal being 100 lbs., and Dr. Weddell justly observes, that “it is difficult for the forests to supply for any long time so large a demand.”

It belongs to the Natural Order Cinchonads and to Pentandria Monogynia of the Linnæan system. It has been beautifully figured in *Paxton's Flower Garden*, pl. 107;

and for the following description and directions for its culture, we are indebted to the Journal of the London Horticultural Society.

“Leaves oblong, blunt, pale dull green, tapering gradually into the leaf-stalk, which is red, as well as the midrib itself; at the back of the leaf, in the axil of each principal vein, is a small excavation closed up by hairs. The stipules, which fall off very early, are a pair of oblong, erect, blunt, smooth plates. The flowers appear in panicles at the ends of the lateral shoots, are of a pale pink colour before expansion, almost white when fully open, and emit a most agreeable weak balsamic fragrance. The calyx is a small superior five-toothed cup, covered with fine close down like the branches of the panicle. The corolla has a cylindrical tube about half-an-inch long, and a reflexed five-lobed limb, copiously fringed with long transparent club-shaped hairs. The stamens are five, and can just be seen when looking down into the tube of the corolla.

“This plant has been found to require very peculiar management. Mr. George Gordon, under whose care it flowered in the Society's Garden, states the following to be the manner in which the specimen was treated which bloomed so abundantly in the Society's stove:—

“The seeds, when received from Mr. Pentland in the middle of October, 1848, were sown in shallow pans, well drained, in a mixture of equal parts of sandy loam and fibry peat, and placed in a close warm pit, remaining for ten days without receiving any water after sowing. Afterwards they were slightly sprinkled as the soil became dry on the surface, and at the end of about three months of such treatment the young plants began to make their appearance, in the latter part of January. When the seedlings had made a couple of rough leaves they were carefully removed, and placed singly in three-inch pots (small sixtys), potting them in a mixture composed of equal parts of sandy loam, fibry peat, and well-decayed leaf mould, and after a copious watering were returned to the close pit, where they soon began to grow freely. When the young plants were well established a moderate portion of air was given over head, by pushing down the light a little at the top; and this treatment was continued until the latter part of the following autumn, when the plants were removed to a close pit with rather a drier atmosphere, more light, and a temperature from 50° to 55° by night. Subsequently the plants were shifted as they required it into larger pots, using the same kind of compost as before. As the specimens grew up they showed little tendency to form lateral branches, but became straight-stemmed with hardly a side-shoot. To counteract this as much as possible, I endeavoured to cause the plants to become bushy, first by pinching off the leading points of two plants while in a very young state; but that operation threw the plants into a bad state of health, and one of them eventually died. The other plants were allowed to grow for another season, and when the wood became hard or ripe, two more had their leading points removed, but with little better success. The remainder had at the same time their leading points tied down in a circular form, which in most cases caused the plant to throw out lateral branches. When the wood of these laterals again became firm, or what is termed about three-parts ripe, they were again tied down and allowed to remain so until the wood became set in a curved form, after which the ties were removed and the plant allowed its full motion, for I found if the branches were kept constantly tied down the plants became unhealthy,

and in some cases even perished. By a continuation of this treatment I obtained the fine plant which flowered in the Society's Garden, having twelve panicles of flowers on the points of the lateral branches by the first week in September, 1852.

"In cultivation, I find this plant is easily injured by exposure to dry or cold draughts of air, for it is very impatient of direct currents and bright sunshine. For the *Calisaya*, as for many other plants which are difficult to manage in cultivation, nothing is better than plunging their pots in a very gentle bottom-heat to keep the roots moist and warm, and in an equal temperature, and to give air from overhead, shading also during bright sunshine. No method of giving air or putting the air in motion surpasses that of opening the lights above the plants at top, for no sooner is the light let down than the stream of heated air which rushes out is forcibly met by the cold air endeavouring to enter, the result of which is a proper medium of heat and moisture. It is very injurious to such plants as the *Cinchona Calisaya* to admit direct currents of cold air on a level with or below the plants. It is sure to rob the atmosphere of its moisture first and the plant afterwards, and by so doing causes the plant to flag; no plant, indeed, can thrive when acted upon in such a manner either by cold or dry air. This is one of the principal things to be observed in the management of the *Calisaya*. A moderate degree of heat and moisture are essential points, provided the moisture never becomes stagnant, or the air over dry by heat, especially when the plants are making fresh growth, and the leaves are young and tender. At other times when the plants have completed their growth a much drier and

cooler atmosphere is desirable, provided the plants are not exposed to extremes of either droughts or colds for too great a length of time. In whatever state the plants may be, always avoid dry-air draughts.

"In growing the '*Calisaya*,' the most suitable climate would in general be that of a house, treated in the same way as one for Mexican and Guatemala Orchids, where it is easy to avoid too much heat and moisture during the season of rest, and to give a liberal supply of both, with ample shade, when making new growth.

"The *Calisaya* is increased either by seeds treated as above stated, or by small lateral shoots as cuttings, when half ripened or just before the young wood becomes of a brown colour. The cutting should be taken off with a heel, close to the previous growth, and placed in silver sand, with as many of the leaves upon the cutting as possible. The pot containing the cuttings must be plunged in a slight bottom-heat, and be covered with a bell-glass, and afterwards treated in the usual way. The seeds should be sown whenever received, whether in mid-winter or at any other time.

"This plant is too difficult to manage, and requires too much attention to become very common, especially as it is not very showy when in bloom, although remarkably fragrant and singular for its panicles of small hairy white flowers, slightly tinged with blush on the outer side, in form much like those of the common Lilac.

"It commences flowering about the end of August, and will continue in succession at least a month, each flower lasting only two days, after which time it drops off before fading."

In answer to a correspondent, subscribing himself "A Cottager," we have to reply that "The Farnham soil, which is a rich loam, well calculated, as we all know, for Hops," would suit LIQUORICE exactly.

Having obtained some information relative to its growth near Pontefract, in Yorkshire, where it is cultivated, we know not why, more extensively than elsewhere, we shall lay this information before our readers, being persuaded that it is a highly remunerative crop when properly cultivated on a suitable soil.

Our obliging informant, a clergyman near Pontefract, says:—"Last year, an unusually favourable one for this crop, one acre produced about 300 stones of Liquorice, 14 lbs. to the stone." Now it is a curious fact, that although there was such an abundant crop last year, yet it is at present more than usually scarce at Covent Garden, being worth from £50 to £60 per ton, the usual value being from £35 to £40. Now, supposing the usual return is only one ton per acre, instead of one ton 17½ cwt., as in the instance cited by our informant, it would be very remunerative.

Our informant goes on to say:—"It is usually planted in the gardens, or prepared fields in the neighbourhood, in rows like potatoes, and in a dry loam. Cuttings of the roots are employed, and planted at a depth of three inches, the ground having been dug or trenched about two feet deep, with a view of making the soil tight.

"I am not aware of Liquorice being common anywhere except about Pontefract, where they make of it 'Pom-fret Cakes,' a large weight of which my informant, a grocer, has shipped off to *Australia*."

The usual time for planting it is in March, but this year we have no doubt that the early part of April will be a good time for the purpose.

Large quantities are required for the manufacture of

Liquorice cakes; but, if report be true, a still larger amount is purchased by the porter brewers.

As we gave prominence to a criticism of the prize list and rules of *The Bath and West of England Poultry Exhibition*, to be held at Plymouth, in June next, it is but equitable that we give equal prominence to the Secretary's reply. It is as follows:—

"My attention has been called to an article in your paper, dated March the 10th, wherein I see the rules of the Bath and West of England Agricultural Society's Poultry Show, for June 8th, 9th, and 10th next, to be held at Plymouth, are completely misinterpreted; nothing could possibly be more foreign from my intentions than the view taken of them.

"I substituted a sliding scale for the amount of entry, according to my view of justice, making all competitors for the larger prizes of £3, such as class 1, 3, 5, 7, 9, pay an entrance fee of 3s. 6d. for each coop.

"Competitors for a £2 prize, such as class 20, and 29, pay 2s. 6d. entry.

"Competitors for a £1 10s. prize, such as class 2, 4, 6, 8, 10, 30, pay 2s. entry.

"Competitors for £1 prize, such as class 11, 12, 13, 14, 15, 16, 17, 18, 19, 21, 22, 23, 24, 25, 26, 27, 28, 31, 32, 33, 34, 35, 36, 37, and 38, pay an entrance of 1s. 6d.

"Had I intended the view taken of them, I most certainly should have subdivided the classes, and, instead of giving 1st, 2nd, and 3rd prizes in the particular classes, have made them separate ones, and varied the colour or comb.

"As steward and director of this show, and as the framer of the rules, I should feel particularly obliged if you will give the correct version of them your utmost publicity, otherwise, with the present impression, exhibitors of first-rate birds, thinking if they did not get the £3 prize, they would be excluded from the £2, second prize, provided the judges deemed them the second best, or the 20s. prize, if third best, very many would object to send at all in consequence.

"In the same paper I noticed several remarks, on which I will comment; and as the first alludes to the *season* of the year, I can at once satisfy the public that our agricultural show of stock and implements, takes place on these days. As one of the council of that Society, I with some difficulty got up

our first poultry exhibition, in conjunction with the Society, and held our first meeting at Taunton, in June 1852, and that having gone off very satisfactorily, I again proposed our second to be held during our agricultural meeting at Plymouth, and as I was rather reprimanded for not giving prizes to *chickens* at Taunton, it was thought better to become more perfect, and do so at Plymouth; but your correspondent appears to think it too early. So, Mr. Editor, you see I am like the man in the fable that we have all read of so frequently.

"The next remark alludes to our cutting out *Black and White Cochins*, and the *Gold and Silver-spangled Hamburgs*, and *Pigeons*. Did your correspondent know the difficulty to raise the cash for the present list presented to the public, I think he would, in the generousness of his heart, send us five or ten pounds, and to afford the opportunity to him or any one else (interested in poultry shows), I shall put my full address at the bottom of this letter, and the money shall be appropriated to, I hope, a more perfect list, when we hold our annual meeting at Bath, in June 1854.

"I must tell you, Mr. Editor, we made no charge at Taunton for visitors to our show. The prize list there, as at Plymouth, being entirely private subscriptions, and you must allow that those who have found the means are somewhat entitled to a little choice. And now I have disposed of the remark on *Silks*.

"Now for the unfortunate *Hybrids*. It appears they are considered to be of Polish extraction alone. Such is not my intention. I take a wider view, viz., that of all nations; but am sorry the printer did not give a more expensive type, and make them appear more distinct.

"I believe I have given reason for all remarks but one, and that one, in my idea, rather an important one, namely, *post entry*. Our stock and implement entries close on the 15th of April. Our poultry show is subject to the same rules, but as that is very early, especially for chickens, we open the books to the 1st of May, at double the previous entrance fees. One reason being to accommodate exhibitors who are after date, and the other, and most important one, to increase our funds, and help to pay for the handsome tent accommodation; the bountiful supply of the best food; the protection of the poultry by police, by night and by day; the very great cost for cups; security and locks for coops, clerks, check-takers, sand, sawdust, and an honest man to break every egg.

"You must be perfectly aware that the sum of 2s. 6d. entry will very little more than cover the hire of coops alone. And I do not see why exhibitors should not pay a much larger proportion than is usual, more especially when we can offer them a free transit (through the great liberality of the Great Western, the Bristol and Exeter, and South Devon railways) for their specimens, both to and from the show, provided they are not sold.

"I must offer you my apology for so long a letter, and am sorry our honorary secretary should have taken the wrong view; or, perhaps, to speak more correctly, I am sorry I did not particularise the different classes in the first instance.

"I have forwarded to you a new folding poultry-basket of my invention, and most ably carried out by the Blind Asylum, at Clifton, to whom I am indebted for the makers. The great advantage is the convenience of package, as when folded, three feet by two feet six inches, and two feet six inches, occupy less than six inches in width, and the weight is a mere trifle. The object—to support a good charity.—JONATHAN GRAY, *Bathwick Hill, Bath.*"

We consider this letter sufficiently explanatory, but that it was required, is evidenced by the fact that Mr. Mullen, the local secretary, did not understand the prize list to be offered upon the terms Mr. Gray now states. On the comparative amount of the prizes offered we might have said something, but we are turned from our purpose, by the statement that the funds would not justify a larger amount. Indeed, for the eight first classes, they are abundantly liberal; but we know of no reason justifying giving prizes of the highest value to

the Game classes, in preference to the *Polands* and *Hamburgs*.

COVENT GARDEN.

THERE has been little fluctuation either in the prices or the supplies of garden produce during the past week, and the quotations which we gave in our last report are still equally applicable on this occasion. There is enough of *Rhubarb*, *Sea-Kale*, and *Asparagus* for the demand, and all other articles are equally abundant. Fruit, however, is an exception, there being, even in *Apples*, a very short supply. The varieties which we have observed most general are a few *Golden Knobs* and *Winter Greenings*, or, as they are sometimes absurdly called, *French Crabs*. We observed also a few rather shrivelled *Alfristons*, a large and excellent culinary apple, which is cultivated in Sussex under the name of *Shepherd's Seedling*, but which being sent some years ago to the Horticultural Society by a gentleman residing at Alfriston, it was named the *Alfriston Apple*; the name by which it is best known, however, in Sussex is *Shepherd's Seedling*. There are still a few *Buerré de Rance* Pears, but none else of consequence.

The plants and flowers are very plentiful, and consist principally of *Camellias*, *Roses*, *Heaths*, *Geraniums*, *Tulips*, *Primroses*, *Violets*, *Snowdrops*, *Hyacinths*, and *Crocuses*.
H.

GOSSIP AND GLEANINGS.

ONE of the most difficult of all the branches of the Horticulturist's art on which to write instructively, as well as agreeably, is Landscape Gardening. A hundred men can be found to write graphically on the picturesque and the beautiful, but the difficulty is to find those who will teach how to imitate what is desirable to be copied. Knowing this difficulty, we have been more than well-pleased to meet with *The Theory and Practice of Landscape Gardening*, by Mr. Joshua Major, of Knowsthorpe, near Leeds. This gentleman has been practising, for some forty years, what he teaches in this volume, and he has contrived to include in its pages more plainly-told common sense than it is usual to meet with in such publications. To say that we do not agree with all his opinions is saying no more than that we did not write what we read in it—for none but the author of any book, probably, ever assented to all that it would teach.

We have many passages marked in Mr. Major's volume as worthy of notice, but at present we can find room for the following only; and we quote it because it demonstrates what is the characteristic of the book—the useful and the comfortable are combined with the beautiful.

"In the formation of a new place I should always have a straight walk of gravel or flags along the front of the house, whatever may be the style of the mansion. I have no objection to the introduction of the terrace wall, balustrades, steps, vases, and other architectural decorations, in accordance with the general style of the building. Indeed, to all good houses these accompaniments ought never to be

wanting, as they not only apparently add to their strength, and form a base to them, but by seeming a part, they increase the extent, importance, and richness of the whole. In places of pretension the entrance court and stable yard should also be enclosed (as shown in the general plan for a palace or mansion grounds) by proper ornamental walls, embellished with vases, urns, &c.; and in arranging these accompaniments I should place the terrace wall (as I have stated a few pages before) from twenty-five to forty-five feet from the house, according to the extent of the building. But this must be apportioned with judgment and caution; for, on looking from the house, were the distance of it too great and the wall too high, the lawn beyond would on the one hand appear too contracted, and on the other, in approaching the house from the park, the connection of the two would be completely destroyed, for it would prevent the wall, with its decorations, and house from appearing as a whole with a variety of composition—a thing I am most anxious to secure. Midway between the house and wall I should have a straight walk, from seven to twelve feet wide, extending the whole length of the building, and in some cases even as far as the walls, enclosing the various offices or outbuildings, if the extent and magnitude of the residence should seem to demand it (as represented in both general plans). On each side of this terrace walk I would have formal flower beds for the reception of early flowers, and other pleasing plants, to be introduced from the greenhouse or reserve garden as they come into bloom. These beds should have an edging of rich ornamental cast-iron work, or stone, or clay, or terra cotta, from six to nine inches deep; and for the sake of variety, especially in the round beds, strong wire basket work. Thus a gay, beautiful, and harmonious display would be produced. With the present cheapness of glass, the propriety of ornamental plant protectors, made to fit the beds within the baskets, suggests itself. These should be octagonal. The frames would be best made of cast-iron, from four to five feet in diameter, and from two feet six inches to three feet high, and as light as possible. They should be provided with moveable tops, to prevent the frame having to be removed more than is absolutely necessary, and in order to be convenient for ventilation and watering—(a small lid would be convenient for that purpose when much ventilation was not required). In this way beautiful plants, too tender to stand without occasional protection, might be exhibited in the spring months in the beds in front of the windows. So far, then, I admit and entirely approve of the formal style, without at all taking into consideration the character of the edifice; but, beyond this, the formal or geometrical style has no right whatever to be claimed by any style of edifice; and to copy the stiffness and absurdities of antiquity in the formation of a new place, is not only erroneous, but absolutely barbarous."

We have been asked by several correspondents where they can procure the large *Bell-glasses* which we have more than once mentioned as being at the Horticultural Society's Rooms, in Regent-street, and which are so extensively employed by the market-gardeners round Paris. At present we can only reply, that any glass manufacturer can supply them, if he pleases; and that the price ought to be from ten to twelve-pence. In France they cost about eight-pence. As they have been employed there for more than two centuries, we can only account for their not now being employed here upon the supposition that the glass manufacturers have not yet sufficiently become acquainted with the wants they can supply now that the excise duty is removed from their material. We say, not *now* employed here, because we believe, in the days of Switzer, and even earlier, these large "bell-glasses" were commonly employed by gardeners, and that their manufacture was extinguished by the imposition of the excise duty on glass in 1694. The number of these Bell-glasses (*Cloches*) employed about Paris only is estimated at

more than one-million-and-a-half, and are used in the raising of early salads, melons, &c.

Mr. Stephens' collection of *British Insects* has been purchased by the Trustees of the British Museum, and will be added to its Entomological department.

There was an extra sale of *Poultry*, by Mr. Stevens, on the 22nd, at which the high prices we have recently had to report were fully maintained. Of Mr. Fletcher's stock, Lot 46, a buff Shanghae pullet, was knocked down for £17 17s. Lot 47, a Shanghae cock, about 21 months old, and which gained a prize at Birmingham in 1851, when exhibited by Mr. Andrews, £17. Lot 48, a light cinnamon Shanghae hen, of similar age and history, £9 15s. Lot 52, Shanghae hen, exhibited by Mr. Sturgeon, at Birmingham, in 1851, and in the pen to which a first prize was awarded, £12 12s. Of Mr. Gilbert's stock, a buff Shanghae pullet, Lot 73, sold for £10 10s. The great prices given for this kind of poultry has suggested the breeding of them in a warm district of France, and bringing them here for sale. There were about seventy lots of poultry, brought from Marseilles, sold on the present occasion. They were very good buff birds, and many of them fetched from four pounds to nine guineas. A white Imperial *Malay* cock and two hens (Lot 164) sold for £4 15s. There were also some moderate Golden-spangled and White *Polands*, which realised from £3 to £4 5s. each. The Whites were the best, but all were remarkable for the extraordinarily large size of their crests, or top-knots. There were a few lots of what were called *Chamois* fowls, but they seemed to be no more than mongrel White *Polands*, differing from them chiefly in having a tinge of yellow upon the points of some of their feathers.

The *Great Northern Association* have announced their Exhibition of Pigs and Poultry to be held at Doncaster, on the 30th of November and 1st of December next. Their prize-list is both liberal and well-arranged; and we are glad to find that the "*Shanghae*" has there succeeded to "*Cochin-China*" in the heading of those classes which are destined for the birds, which, erroneously as we think, have been commonly called by the latter name. We should have liked to have seen a prize for *young Geese*, as we are inclined to think that all poultry less than a year old should compete among themselves only; and we miss *Guinea fowls*, which, in a strictly economical point of view, have so many good points, both as layers and dead poultry, that we should have pleaded for this continuance in the list. The regulations of this Society are among the best we have yet seen; and the arrangements for selling the prize and commended birds by auction will obviate, as we trust, the difficulties that occurred at the late Metropolitan sale. A fine for parties who enter pens, and fail to exhibit, or to give due notice of their intention not to do so to the Secretary, would be a useful addition to the rules of other societies.—W.

PLANTING AN ORCHARD OR FRUIT-GARDEN.

A VERY general desire appears to exist amongst the classes for whom THE COTTAGE GARDENER endeavours to furnish advice for more practical information concerning the fruit-garden, or orchard; and I feel called upon to enter on the subject. The information desired seems to be quite of a rudimentary character—tracing the fruit and vegetable garden from its commencement, through its rise, to its complete establishment. It will, therefore, be necessary to follow the subject out as much as possible in a connected way, to show the order, dependency, and connection of the various links in this gardening chain. To endeavour to furnish articles weekly, as much as possible applicable to the current operations necessary, has been hitherto, in the main, the aim of the writers employed on this work; and to make those articles, as Mr. Beaton has judiciously observed, a sort of “Companion to the Calendar.” This, I say, has been much practised, and has, doubtless, been productive of some benefit. Such a course, however, has its faults as well as merits—at least, as far as concerns one portion of our readers: it prevents that connection in the subjects handled which those who are seeking the mere alphabet of gardening so much desire. I infer, therefore, that it will be useful to many of our readers occasionally to vary our course.

In order to make such advice equal to the case of an uninformed beginner about to make a new garden out of hitherto unenclosed lands—at least, as far as garden walling is concerned—we will suppose a case which requires everything doing to it—drainage, enclosure, walks to make, borders to regulate, stations for trees to prepare, trees to select and plant, with pruning and subsequent treatment, &c.; and, in addition, compartments for vegetable culture to be established.

DRAINAGE.—This is the first point in all new enclosures for gardening purposes; a stagnant soil can never prove satisfactory, be it ever so good. Before the walls are built this matter must be attended to, for, if the process be necessary, a main drain or two may have to pass through some portion of the walling, and this should be ascertained. Deep holes should be dug in three or four places—say six feet—in order to ascertain to what height the water rises. If the ground is partial in character—that is to say, some portions inclining to one class of soil, some to another—the character of each class should be ascertained in this respect. Such examination should take place after a wet period, if possible, in order that the improver may know the worst. If drainage be requisite, and the ground is of very limited extent, a line of main drain should be so contrived as to receive with facility, and at the least expense, whatever subordinate or branch drains may be necessary. Some judgment must be exercised in all these things, in order to secure both economy and efficiency. It is possible that a main drain of this character may be made available for other purposes *outside* the walls, or structures may be required within, for which it will be necessary to provide deep drainage. To carry all such objects in a business-like way the proprietor must have fully made up his mind as to his requirements. Hesitation proves fatal to many a plan. Be these things as they may, a good main drain of some depth—not less than four feet—should be established, and, of course, a good outlet must be secured to it, and its direction marked well by signals, to provide for future contingencies. Those who are about such things should remember, that unless their “main” be deep, the branch drains cannot be; and let it be borne in mind, that numerous complaints, well established, have been made of the fibres of roots, such as of Beet, or Mangold, and others, descending into and choking shallow drains during our summer droughts. Most of

our ordinary vegetables descend much deeper than people imagine. I have traced *Onion fibres* forty-two inches, *Asparagus* forty-eight, and so on; but then there are the fruit-trees, which, if they escape their bounds, may go much deeper, and produce what have been termed “foxtail roots,” which our readers may have noticed. These soon decide the fate of a drain; a better stop could scarcely be invented. No sooner is such a “brush” of fibres, which the title so aptly describes, produced, than sediment of some kind speedily collects.

I would here suggest that no drain should approach a tree or trees nearer than twelve feet, and that, if possible, none be less than five feet in depth.

WALLS.—We must here suppose the plot well drained, and ready for building the walls. Opinions differ among practical men as to the *form* of a plot intended as a fruit and vegetable garden; for my part, I should prefer a parallelogram, following the cardinal points; the east and west sides one-third longer than the south and north. This plan I should adopt as far as possible, nearly up to the Scottish border, when it would become a consideration whether the south and north sides might not be equal to the others, or, in other words, an exact square; and, further north still, it might become necessary to give the south and north lines the advantage.

The question appears to me to assume this shape, in consequence of the great accession of valuable Pears in later years, many of which require a wall, and for most of them an east and west aspect will be sufficient. It is evident, that as we increase the proportion of south and north sides, so, in like manner, is there a corresponding increase of bad aspect, viz., the northern, which, however good it may be for some things, it is not desirable to increase.

As to the height of walls, that is a matter much dependent on the means and aims of the proprietor. The best height for ordinary cases, is, I think, twelve feet; and if the owner choose to add another foot or two for shelter in a cold district, so much the better. They are not so convenient, however, below ten feet, which I suggest as the minimum height for *boundary walls*. Sometimes it becomes desirable to build cross *interior* walls; such may, if necessary, be made lower. There has been some discussion about the *form* of walls, but I believe most practical men are in favour of simplicity; that is to say, right lines, and perpendicular.

It is the ordinary practice to build garden-walls of brick-and-a-half work, or what is termed “fourteen-inch walls,” in the country; and doubtless, at ordinary heights, this substance of wall is necessary. Garden-walls, however, are at the best expensive; and as not all concerned may require the height usual in large gardens, we may fairly enquire, whether bricks can be economized by lessening the thickness as well as height of the walls. I have seen walls, in my time, of both heavy and light proportions; and have moreover known walls to blow down; but, on consulting an old and knowing bricklayer, as to the amount of strength necessary, I find that he is less venturesome than I should be. He thinks that a nine-inch wall, or single brick thick, might do up to nearly seven feet, but would not trust it any higher without buttresses or stays. A fourteen-inch wall, or brick-and-a-half work, he would warrant up to twelve or fourteen feet, which, indeed, is as high as garden walls are ever carried. Now, I would undertake to grow successfully any of our garden fruits on a five-foot wall, but such would require peculiar treatment during the first three years after planting, and might prove rather unsuccessful in inexperienced hands.

I may here point to *copings*, without which no garden wall is complete. Some have them fixed; others movable. The latter *must be right*, whatever may be said of the former. It so happens that ours are fixed, and they

project nine inches: they are of stone. The copings I have to suggest are of a moveable character, and should project quite a foot; and wood will be found the most eligible material. The wall builders, in this case, must remember to build in some iron brackets for sustaining them; their distances being, of course, ruled by the length of boarding employed. These brackets must be firmly fixed, and be strong in themselves, in order to bear their burden safely. It would be well to carry them through the wall, with a "T-end" in the opposite side for strength; but however done, they must be firm.

On the side designed for protection, the irons must, of course, have a return-end, to sustain the boards in their place. During June, July, and August, the boards may be taken down and housed until September, when they may again be put in requisition; at which period, by keeping the trees dry, and impeding radiation from the wall during the night, they will promote the ripening of the wood.

We come now to the WALKS requisite. These are sometimes obliged to be in part ruled by existing *outer walks*, but the best plan is to throw the interior area into four squares, or quarters, be the size what it may. If the extent is *very* considerable, it may be necessary to subdivide these quarters: from thirty to fifty yards in length makes a good cropping line for vegetables; a much greater length is inconvenient, as causing much trouble in shifting the garden lines for vegetable operations; and, moreover, in drill drawing, a line of more than fifty yards is weak, and requires to be sustained with side pegs; all this occasions loss of time. Our quarters here are just fifty yards in length, and we find them tolerably convenient, but should not desire them to be longer. It must here be observed, however, that if the margins of the quarters are to be occupied with dwarfed fruit-trees, it is by no means expedient to have the quarters any smaller than the minimum length here offered. When such is the case, the whole area becomes so blocked up when the trees attain their full stature, that there is no "breathing space" for vegetables; all becomes confused, and, of course, what crops can be obtained will prove of very inferior quality.

We must come now to the width of the walks, both principal and subordinate; such considerations being forced into the subject through the necessity of paying a due regard to the trees, as to distance and other subsequent arrangements. Of course, the width of the walks must, in some degree, depend on the size and general style of the gardens—what width is really requisite for the trees as breathing-room, and to facilitate all future operations, is the primary consideration; and next to this principle, proportion, and convenience for walking must be thought of. Proportion, of course, refers to the general style and pretensions of the grounds; and as to convenience, that depends on the requirements of the family. If the main lines of such a garden are to become an occasional promenade, and the place is rather roomy, seven feet in width for the chief walks will not be too much; but if the most severe economy is required, five feet must suffice; less, for this style of garden, I dare not advise. Now, to steal a march on our subject for a moment. The walks being at a minimum point—five feet, and, let us say, the dwarfing fruit trees about twelve feet apart, and at four feet from the edge of the walk—they will each have four feet room to stretch on the walk side, and six feet in the border line; but then they may—where room *must be economised*—be permitted a little occasional liberty, a slight trespass over the border-line, unless on trellises; when, of course, the whole thing becomes more precise.

Let not our readers, however, imagine that a foot of extra room is thrown away altogether in the case of fruit trees; a foot in width, as to rows of Cabbages, or other vegetable crops, is a consideration; such may be cal-

culated on to an inch; but they produce no branches—their growth is more regular, and they are more ephemeral in their nature. I have seen many a garden in which both fruits and vegetables were severely injured annually by a *false* economy at the outset. In this, as in most other affairs of life, much depends on having a *distinct* aim at the outset.

WATER.—I must stay a moment at this point, to urge the great importance of establishing a piece of water in the centre of every garden, if a permanent supply can be had. It is impossible to over-estimate the benefits and conveniences resulting from this source. It is all very proper to talk about thorough drainage, but our friends must remember, that some soils inclined to be stagnant, are, nevertheless, subject to occasional droughts; and that Fruit Trees on a dwarfing system, having their fibres nearer the surface than ordinary standards, are, therefore, more liable to partake of the changes of the atmosphere; and, indeed, are intended to do so: extremes of drought, however, have to be avoided, and especially in the case of heavy crops of fruit; but then there is the vegetable cropping also to be benefited; and it is to me a painful sight to observe a labourer, during drought, carrying cans of hard and cold water from some pump, situated, perhaps, as far on the outside the garden doors as the needy subjects are on the inside. Still, this is not all; during the busy period much watering is neglected under such circumstances.

Let every one establishing a fruit and vegetable garden seriously consider this.

A piece of water of this kind may be circular; may be of brick, cemented, or of stone; the diameter may be partly ruled by the size of the garden, as disproportion is to be avoided: from eight to twelve feet diameter will convey an idea of what is meant. We have such here in three different parts of the gardens, and they are always full, being fed by a HYDRAULIC RAM, which is one of the most useful engines ever invented. Each reservoir has a ball-tap, and then they are self-sustaining.

Such reservoirs should be about fifteen to eighteen inches above the ground level, whatever there may be below it; and, in some cases, it may be expedient to bring the drainage waters of the garden into it.

Those who desire embellishment may choose a fountain in the centre, or may add rock-work, aquatics, and even gold and silver fish. One thing I had almost forgotten to point to, and that is, the superiority of such aired and softened water over that of the pump.

R. ERRINGTON.

MEETING OF THE HORTICULTURAL SOCIETY.—15TH MARCH, 1853.

THIS was the finest day of the first half of March, and the Meeting was unusually crowded. After every seat in the room was occupied, fashionable and more fashionable arrivals were announced, and chairs had to be mustered from a store which is kept in reserve for a heavy push like this. The room was not overcrowded, however, with spring flowers; but we had several things of very great interest, nevertheless; and the most so—as it appeared to me, and I judged from the way the attention of the great "country party" was rivetted on that part of the Lecture—was a piece of the timber of *Fitzroya Patagonica*, from Mr. Standish: a handsome evergreen tree, which I lately described, and which is as hardy as our Yew, and seems to grow as fast as a Poplar. Now, we know the kind of timber it produces on the western slopes of the Patagonian Alps; and we can affirm that, in addition to its being one of the newest and most graceful-looking of all our hardy trees, it is also of the highest promise in respect to the yield of timber, and to its value when we have it in sufficient

quantity for sale. It seems as hard as the best mahogany, and of a better colour, with the grain as close as the red cedar used for pencils, and very much in that style. I should not think it quite so heavy as mahogany, but for all kinds of furniture and ornamental work, in which mahogany is now used, I should prefer the *Fitzroy* wood, because I am sure it will take a finer polish, and look richer than mahogany when stained or varnished. Then, if our hills and waste lands would produce such timber, and the great probability is that such will be the case, no wonder that the "landed interest" showed most attention and anxiety at this part of the lecture; so much so, that the drop of a pin would have made a noise. There was also a sample of the bark of *Fitzroya* exhibited, but not the very outer coating. The inner bark is very thick, soft to the touch, and of the same cedar colour as the wood. Some of those present thought the thickness of the bark was a provision of nature to screen the wood or tree from the rigour of the climate, which is proverbial along that range. But surely that, and other fanciful ideas to the same effect, must be altogether wrong. The bark of the Scotch Fir is not thicker at the northern extremity of its range, in Europe or America, than it is at the southern limit. And the Cork-tree fails to yield the bark of equal thickness in the same ratio as it is introduced into a more severe climate.

The next greatest novelty was a seed-cone of one of the huge Pines growing in Moreton Bay, and other islands in the South Pacific—one of the *Araucarias*, called *Bidwilliana*, after Mr. Bidwill. This cone is not more than six or seven inches long, but its thickness is nearly equal to its length all the way through, and flat at both ends. It was said that this kind might stand out our climate in the south of Ireland, and even in the south of England, in dry, well-sheltered situations. But its great value could only be brought out in some of our colonies in a warmer climate, where, besides timber, shade, and shelter, the seeds of it would become an article of food. These seeds are nearly as large as beans, and as good and nourishing to eat.

Speaking of food, we had here, to-day, another instance of the value of gathering all sorts of useful plants into one place or garden to investigate their comparative merits. It is now found out, and proved beyond a doubt, that the *Indian Corn* which they grow at Cusco is as far superior to the Maize of North America, as is the distance between Washington and Cusco, or any part of the Bolivian Andes. We had several heads of the Cusco Maize on the table, in illustration and support of all this. Experience does not say that this better Maize is more hardy for our climate; but the fact of its being a better article at the diggings, or Algoa Bay, than the kind universally in use, should not be lost sight of. If it was worth while to make a rush for the tea seeds distributed at the last meeting, surely this Cusco Corn is worth looking after. If I were going out to Australia to-morrow, I know of a much better way of "digging for gold" than making holes and washing the earth. I would take out some of all the best vegetable seeds in Europe, the best salads, the best herbs, the best roots, the best of every thing; and now that there is an Association (the Pomological and Horticultural) of influential people, formed on sound trade principles, and that they pay me a regular salary to be their Inspector, or kind of Exciseman, to look after stores, weights, and samples, I am now personally interested to see all these things packed in the best manner for all parts under the sun.

Of *Cut Flowers* we had two beautiful *Water Lilies* (*Nymphaea*), the blue and white, from Mr. Weeks's stoves, the celebrated grower of the Victoria Water Lily in the open pond. He also sent a very beautiful Bromelwort on a block of wood, like a regular air plant. They call

this a *Puya*, but that is one of those modern invasions, now so common, of substituting new names for old ones, against which no legal claims can be produced. The real name is *Pourettia longifolia*; *Puya* is a synonyme. The plant is a dense mass of small bastard bulbs, with long, narrow, hard, dry leaves, and grows on trees or rocks, or any support that comes in the way, just like an exotic orchid. It flourishes through the summer, goes to rest in winter, when the leaves drop off, and then it looks as if it was a dead mass of tangled roots; but in the spring the flower buds give the first note of returning life, and the leaves come soon after. When I first saw it at a distance, on entering the room, I mistook it for a new scarlet *Æschynanth*, and that gives a good idea of the plant in flower. The flowers are numerous, and of the brightest scarlet hue; they come directly from the roots, and continue five or six weeks, if not longer. This specimen was in flower for the last month, and it looked as fresh as ever; the price is from 10s. to 40s., according to size, and I should say it is as easy to grow as a Cactus or *Pitcairnea*.

There was a beautiful prickly Cayenne *Pine Apple*, weighing above 5 lb., from Mr. Bailey, of Shardeloes; and before the meeting, there was a consultation upon Pines in general, among some grey heads, the result of which, and I promised to give it, was, that there are only three kinds of Pine Apples known that are deserving of cultivation in this country:—this *Cayenne*, the true *Black Jamaica*, and the *Queen*; and the latter they put down as only fit for table from May to October; the other two all the year round, and the only two worth tasting in winter;—but that in many parts of Yorkshire, Lancashire, and Cheshire, a very inferior pine, with tremendous long leaves—the *Monserrat* Pine Apple—is cultivated under the name of *Black Jamaica*; and that the whole breed of this *Monserrat*, *Enviles*, *Havannahs*, and such like, ought to be annihilated, to make room for the three aforesaid.

About *Grapes* I have seldom been more gratified than now. I am never satisfied without personally testing any new fruit or flower; and some may recollect what I said last autumn about this Society and the *Black Barbarossa* Grape. Let bygones be bygones, however; but this is, without the slightest shadow of a doubt, a better hanging Grape than the *Black St. Peter*, and as good to eat as the *Black Hamburg*, and the *St. Peter* is not better. On the 15th of March we had two bunches of the *Muscat of Alexandria*, slightly shrivelled, it is true, but none the worse for the top of a dish in a first-rate dessert. Between the two was a bunch of the *Black Barbarossa*, looking just as fresh as it did last September, for I have examined the whole of it, round and round; the bloom was perfect also; indeed, it looked so much like a bunch of this year's growth, that the lecturer had to tell the difference, for fear we should run away with that idea, for we all had seen as good new grapes from Mr. Forbes, the Duke of Bedford's gardener, six weeks before. We had also the history of it in the lecture, as far as it can be traced. The late Mr. Ward, of the Isle of Wight, brought it first into notice, and gave cuttings of it to his friends. He gathered Grapes, and other fruits and flowers, from all parts of the world, to be compared, under his own eye, in that favourable climate, and this grape appears to have been his favourite; but the memorandum about where he had it from was lost before the value of the fruit was ascertained, and so far, the name *Barbarossa* is fictitious; and if the verdict of a certain number of gardeners, whose hair has turned grizzly cultivating the *Black Hambrough*, is of any worth in this question, the *Black Barbarossa* is a seedling from the *Black Hambrough*, and the best seedling, too, since the day the *Esperione* was first proved; the new seedling being the best keeper of all Grapes, whatever, and the *Esperione* the hardiest Grape of all the *Black*

Hambrough breed; and that I can attest myself, from growing a collection of them against each other, on the open wall, for ten years in succession. I once grew a German Grape very much like this *Barbarossa*, it was called *Schwarzel Haanglin*. In the last week in September, 1836, it was ripe on the open wall, and I showed it to Mr. Thompson, the great authority for fruits at the Horticultural Society. There have been some enquiries about the new *Barbarossa*, but as the price is high, and the kind was not yet proved to our satisfaction, we rather put a damper on it; but now there is no question about it, and we say, at once, that it requires the same kind of treatment as the Black Hambrough, and that it is the best keeping grape in cultivation; and were it only to see this one question proved, no Fellow of the Society ought to grudge a journey to Regent Street.

Of the *Orchid* family, the best in the room was a large, fine specimen plant of *Dendrobium nobile Blandianum*, a variety as superior to the old *nobile* as *nobile* itself is to a Cuckoo flower. This was from the stoves of the society, where I saw it, for the first time, the day they were lifting the large tree; and I saw another *Dendrobium (speciosum)*, that day, for the first time in flower, one of the most profusely flowering Orchids I ever set my eye upon; and one, which I have since learned, that several people flowered this winter, without knowing what it really was, and had to send spikes of it to London to learn the name. This, one of the oldest of Orchids, is one of the easiest to keep, but the worst to flower, without a particular treatment, such as, I believe, Mr. Appleby recommended. I also saw a lovely new Orchid, in the same house, which opened its beautiful flowers this month, for the first time in England. It is a *Cattleya*, called, or to be called, *pallida*. It belongs to the same section as *Mossie*, and had two flowers on each shoot; the colour, all over, is a mixture of snow-white, soft cream, and light violet, just such a flower as one might wish for a wedding nosegay, and, like many of them, they long continue in their prime.

One cannot write a word about new Orchids without the wish recurring that we could cross them, so as to render them more hardy, if not varied in colours and less difficult to manage for amateurs; but, in truth, we can cross them easily enough, and get the seeds to ripen, too, and the seed is as small as the dust in the sun-beam—the difficulty is to get them to sprout, or vegetate, and that difficulty has often been overcome. I, for one, had some hundreds of them in life; but the greatest difficulty of all is to rear them the first season, and no one has yet got over that. But a friend of mine, who is most successful with the more rare and curious things we handle, has just consented to give these Orchid seeds another trial this season, under quite a new and original system, of which both of us entertain great hopes, and I promised to ask for seeds, from all parts, through THE COTTAGE GARDENER; and I do, hereby, most earnestly appeal to each and every grower of Orchids who reads this page, to look out among his plants and see if he can pick up a pod, empty it in a packet, and inclose it for me. It is of little consequence what the kind of Orchid may be—any one will do to test the experiment; but I should like to receive as many kinds as possible, and whatever the issue may be we shall put it on record for the use of others.

But to return to the meeting in Regent-street. The garden of the Society furnished the best of the greenhouse spring flowers without forcing.

Trymalium odoratissimum, trained as an upright bush, was feathered all round, and from the edge of the pot, with creamy-white flowers, on slender spikes and spikelets, after the fashion of *Ceanothus azureus*. This is certainly a very desirable plant to grow for early flowering, and it is as easy to grow and flower as a Fuchsia; and when cuttings of it are taken from a flowering

plant they begin to flower as soon as they form roots. I have seen lots of it so lately in Mr. Jackson's show house, but the flowers are individually so small, that without it is a large specimen plant it makes little show.

Acacia celsa, a very dwarf species, was in full bloom, the branches drooping down over the pot. Years ago, when one mentioned the name of Acacia, it gave the rest the horrors, because no one could build houses then half large enough for them; but now, since we have got the race of low bushy ones, they are among the most fashionable plants we have, and deservedly so, seeing how easy they are to grow, to keep, and to bloom, at a time when flowers are most wanting; for, with a good supply of water at the roots, they can easily be forced to bloom very early in the spring; or, if they are kept in close cold pits, after flowering, till the middle or end of June, they will flower very early without any more forcing. I have seen some in bloom in November.

Polygala Dalmaniana, a good variety in the way of *grandiflora*, seems to be a most useful spring plant, as of late years it figured away in the prize collections at the May shows, and now seeing it in fine bloom two months earlier is as much as to say you can do anything with it. Spring *Heaths*, *Epacrises*, and *Cytisus ramosus*, alias *rodophne*, and *Ceanothus rigidus*, make up the bulk of the rest of this class of flowers, and almost everybody knows all about them.

Besides all these, the *special* things for which prizes were offered were *Salad plants*, forced *Strawberries in pots*, and *Hybrid Rhododendrons*. Old gardeners know very well how difficult it is to show a fine lot of Strawberries in pots, such as Mr. McEwen, gardener to the Duke of Norfolk, sent up last spring; and young gardeners in the country think they would be only laughed at if they were to send up such things in competition against Covent Garden market, where all the best things in the world are sent to. Therefore, "between two stools," the prizes that have been offered for winter salad plants, and forced vegetables and fruit, have not been hard fought for yet, except the "brush" between Mr. Fleming and Mr. Burns, gardener to Lord Stanhope, and the full collections from the grounds of the Society's own gardens, which were very good each time. But the best result of the Society's offerings is, that several varieties of the same kind of thing are shown side by side, so that one can see with one eye, at one glance, and in a warm, comfortable room in the heart of London, what has taken months and months to arrive at, out in the open country, and under all weathers. Next year we are promised to have, not a skirmish, or an off-hand battle, but a regular war to the very roots. Many of the country party have pledged their forces; the right kinds of seeds are to be ordered *now*; and country gardeners are to invade London next winter, determined to take it by force, if not by their forcing products.

Mr. Burns' collection of Salad plants at this Meeting were, blanched entire-leaved *Chicory*; curled and Bata-vian *Endive*; Bath-Cos, and hardy-green *Lettuce*; American, Normandy, Curled, Golden, and Water *Cresses*; Italian *Corn Salad*—the best of all Corn-Salads; White *Mustard*; common Garden *Sorrel*; *Burnet*; Red *Beet*; *Chervil*; Cole's Dwarf red *Celery*; *Tarragon*; early frame *Radishes*; *Ohives*; and Tripoli *Onions*.

D. BEATON.

GARDENING STRUCTURES.

The modes of treating gardening structures will now be occupying much attention, as not only will many be thinking of building for another season, but here, with the weather of Christmas in a Good Friday week, many will have to make sundry make-shifts with their present conveniences. The rearing of a structure for plants, either for ornament or utility, is a good beginning; but

to prevent future disappointment, the means of heating it at will should be left as no future haphazard affair. Much of the comfort and economy will consist in the matter being seen to while the house is building, as no breaking of walls or floors will be needed afterwards. We have already alluded to the importance of large bottles, filled with hot water, for keeping out frost from small places, and a Subscriber has lately testified to their utility. We have seen a neat little house, into which the parlour opened, heated by water circulating in small tin pipes, heated by placing a naphtha lamp under a small concave-bottomed tin kettle in the back kitchen. A late number detailed, how, in urban and suburban districts, where gas is easily and economically comeatable, small places could be heated by sending the heat from the burning gas through small iron pipes, according to Mr. Cuthill's plan; and not seldom, modes have been detailed, how, when circumstances were favourable, and the kitchen and greenhouse somewhat contiguous, and on a similar level, two pipes fixed in the kitchen boiler, with stop-cocks to be used when wanted, would supply an easy mode of heating a greenhouse.

From not attending to some of these little matters some disappointments have taken place when this last mode has been adopted. We will, therefore, mention a few essentials to success.—1st. When the lid of the boiler is moveable, the water in the pipes in the house must not be higher than the top of the boiler, otherwise it would flow over. 2ndly. When the boiler has a fixed lid, and is supplied by a pipe from a cistern at a considerable altitude, the water may easily be raised, as much as the height of one story of rooms above another. 3rdly. In thus raising, it is advisable that the rise should be gradual to the very extremity of the flow-pipe; and then a gradual descent from the return-pipe to the boiler. Every dip and bend, upwards and downwards, suddenly exposes you to a lodging of air at these points every time the pipes cool; and, unless you leave small upright open tubes, fixed in the pipes at these places, to let the air escape as the water presses on it, you will have no circulation; few things being less moveable by heat than a column of air enclosed and pressed upon by two columns of water. A small open tube at such places, when unavoidable, from a quarter to half-inch diameter, is better than turn-cocks or air-pumps, as it is always safe and self-acting. It should be fixed at the ridge of the bend. 4thly. It will be necessary to have a yard, at least, of stout iron piping next the boiler, as other metals might be easier injured by the fire; but after that distance, we would not be particular as to the material for conveying the water to the iron pipes in the house; for though the other week *lead* was mentioned as being objectionable for this purpose, we have, in practice, seen no sufficient reason for objecting to it; while, if the distance to be traversed is considerable, it possesses, we think, two advantages; namely, less power than iron of radiating heat, and, therefore, conducting it to the house better; and then, the *ease* with which it may be bent in any direction, and the necessity for many joints that would be obviated. A pipe of three-quarters of an inch diameter would be sufficient as a carrying medium to a small house; though one inch might be better; but it is amazing how small a pipe will maintain a brisk circulation.

As corroborative of the last position, and as likely to be interesting, we mention the following facts:—In an unheated division of a range of houses, it became desirable to exclude frost in winter, and therefore a single pipe was taken, parallelogram fashion, round the middle of the house, the pipe rising for half its length gently, and then depressing as gently to the boiler. At this highest point a hole was bored in the metal pipe to

receive a cock, such as is used for a beer barrel, to let off the air when it accumulated; for the simple and more efficacious plan of an open tube rising to the height of several feet was not fashionable then. In course of time it became desirable to be able to give a temperature of 60° to this house, instead of 40°, but how to do so, simply and economically, and without interfering with the pipe and boiler, was the question. Well, we solved it in this way. Near to the highest point in the pipe we constructed, beneath the stage, a sparred table, six inches higher than the pipe, to support a zinc box or tank, six feet in length, three feet in breadth, and four inches deep. The tank was divided into three divisions, except at the respective ends, by strips of zinc of the above depth soldered to the bottom, which thus kept lid and bottom from collapsing, and helped the circulation. A lead pipe had one end fixed to the stop cock above referred to, and the other end inside of this table tank at the south-east corner. A similar pipe was fixed inside the bottom of the tank at the north-west corner, and the other end to a similar cock, or spigot, fixed in the pipe, after it had begun to decline to the boiler. The tank was then nearly filled with water, and as soon as the pipes were heated the circulation in the tank commenced, and the water was soon as hot as that in the pipes, while the bottom sides and top being all zinc, the radiation of heat was great.

Now, what we wish to impress are two different things. First, that the whole of the heating and circulation in this table-tank were effected through the small openings in the valves of two common beer-barrel spigots. Perhaps, if the small pipe had been joined to the first metal pipe at once, the heating might have been as well effected; but we wished to have the power of shutting off the heat from this tank at pleasure. The second inference is, that every reader, who heats his house pretty frequently with hot-water pipes, may thus easily obtain a tank for securing bottom-heat for propagating purposes, by connecting it at one corner with the flow-pipe, all the precaution necessary being that the bottom of his tank, in such circumstances, had better be as high as the top of his flow-pipe. Our readers are aware that, by making a substantial tank in the first place, no pipes besides those connecting the boiler and the tank would be necessary; and, with the exception near the furnace above referred to, *lead* will furnish the easiest connecting medium. One of the cheapest, best acting, and most durable, without repairs, tanks we have come across, was made of yellow deal, as carefully constructed as a brewer's cooling vessel, and covered with slate. Two lead pipes communicated with the boiler, and steam, or vapour, was obtained at pleasure, either by watering the slate, or removing places left for openings. We consider that tanks for bottom-heat, with hot-water pipes running through them, are fine things, in these utilitarian days, for those who can draw largely from their gold mines. We have no difficulty in procuring bottom-heat from pipes surrounded with rubble, and when we want a moist bottom-heat, all we have to do is to throw water amongst the stones, bricks, &c.

But this last is a matter we cannot enter upon here. Where much is to be done, hot-water we believe to be the cheapest and the best in the end, as, if the furnace and boiler are large enough, several houses and many pits may be heated from one furnace. In the case, however, of those friends who have merely a small house, and who cannot conveniently adopt any of the modes at first alluded to, then we are somewhat doubtful of the propriety of recommending them to have an independent hot-water apparatus, however small. Where a furnace must be constructed on purpose, we would be inclined, even on the score of economy and neatness, to recommend the old-fashioned flue, and to place it out of

sight beneath the floor. There is no hot-water apparatus, however well fixed, but lets a portion of its heat up the chimney; and, therefore, when using this mode for a large house, it would be advisable to carry a flue through the north wall. Keeping in mind that we recommend a flue only in such small greenhouses, we will illustrate what we mean, by a case. We had such a small house, sixteen feet long, nine feet wide, eleven feet high at back wall, and seven feet in front, four of that being glass. One end was a part of a garden wall, against which the heating power was to be placed, and the other end was mostly glass. An average temperature of 40° in cold weather was wanted. I applied to a tradesman, but as he asked £15 for what we had calculated might be done handsomely for £5, as we were to find the labour and materials of setting the boiler, and constructing the chimney, we left the matter in abeyance, ultimately finding it was no go, the demand was greatly reduced. By this time, we had thought that pipes would be rather in the way, wherever placed, and had resolved upon having a small flue beneath the floor, which was covered with nine-inch paving tiles. A part at the doorway consisted of stone flooring, which we did not wish to disturb, so that the length of the flue, before it turned, was only twelve feet, instead of sixteen feet, making twenty-four feet in all. We removed as many tiles near the front of the house, and what earth we calculated exactly would be necessary; we fixed a small furnace outside the wall, so that the bars of the grating were fifteen inches below the bottom of the flue; and inside the house, the sloping rise to the bottom of the flue was bedded with fire-brick; the bottom of the rest of the flue consisted of common house slate, bedded on the earth in a little mortar. The flue was from four to five inches wide—we intended to form it of two bricks on edge—but wishing to have a hollow place on each side of the go and return flue, so as to give out more heat to the tiles above, the go and return flues being placed side by side, we used three bricks on bed for strength, the three walls thus serving for the two flues; on the top of these slate was again bedded in such a manner that the joints of the slate were crossed by the joints of the paving tiles, which were bedded on the slates with a layer of good mortar between them. It will be seen that the tiles next the flue rest partly on the top of the flue, and partly on the earth on which the floor is laid, leaving a hollow space. A very small fire is felt in a few minutes, and we are rather afraid to state how long a bushel of coals and cinders kept up the requisite heat in the coldest weather we have had this season. In such a position, we would be glad to know of any other mode that would be preferable. Mr. Snow, as previously recorded, has several houses heated in a similar manner. At the point where the flue turns we can take off a tile, and clean in a few minutes; the soot being shoved in one branch to the furnace, and in the other to a moveable iron plate in the chimney. R. FISH.

THE PELARGONIUM.

(Continued from page 484.)

DISEASE.—*The Spot.*—This disease is so named, because it first appears as a small spot near the centre of an otherwise healthy leaf. It gradually spreads until the whole leaf turns yellow and drops off if not removed by hand. The great cause of this disfiguring pest is over-excitement, by heat and moisture during the latter part of summer, and then reducing both these stimulants through autumn and winter. The proportion then between the root action and the surface of the leaf is disarranged, and, the plants having more leaves than they require in such a low temperature to carry

on the functions of growth, parts of the leaves will become diseased or gangrened, with ulcerated spots, a state of life in the plant induced to ease itself of a too great number of leaves. When a plant is in this condition, a low, close atmosphere greatly aggravates the disease, causing it to spread to more leaves than it otherwise would if the internal air of the house was purer and drier. The remedy is obvious—it would not answer to keep up the summer-heat, and amount of water through these late months, for that would cause them to grow weak and lanky, and the leaves would be of a sickly pale colour—that remedy would be worse than the disease. The only means left, then, are to give plenty of air, and keep the walks, &c. as dry as possible, and to remove instantly every leaf that appears the least diseased. In very damp, foggy weather, it would be advisable to give a small amount of artificial heat early in the morning, giving air in the upper parts of the house at the same time. This will cause the stagnant air, overloaded with noxious damp vapours, to fly off into the external atmosphere, and the internal air will be purified. By adopting these precautions the disease will gradually disappear, and the plants will show, by renewed health and colour, that the desired cure has been effected.

4TH. SECTION.—**PREPARING FOR EXHIBITION.**—The cultivator, having paid due attention to his plants in regard to cultivating them, and getting them into bloom in full perfection when the day of exhibition arrives, will be examining and watching his plants with peculiar interest for three weeks before that time comes. They should be trained about that time, so as to have each truss of bloom arranged so as not actually to touch each other, and yet to be so close as to form a dense mass of bloom above the foliage. All blooms likely to be over before the day should be cut off at once, close to the branch, so as not to show they have been in existence. About a week before the show each truss should be tied firmly to a stick to keep it in its place, and these should remain till they arrive at the place of exhibition, that is, if they have to travel a considerable distance, as much, say, as four or five miles, or more. This is rather a troublesome affair; but if not adopted, it is more than likely many of the blooms will, by shaking against each other, be bruised, and rendered unfit for competition. To afford time, the plants should arrive at their destination two or three hours before they are required to be placed on the stage. Any packing the trusses of bloom with cotton, or other kinds of wool, should always be avoided; it is so difficult to remove without injuring the flowers. Supposing they arrive in good condition, then remove the sticks carefully, pick off all injured blossoms, and place them in their appointed place. Should the day be hot, a good watering previous to placing them on the stage will keep them fresh and blooming through the day.

Arrangement.—The largest plants should be placed in the back row, and the smaller in front. Place them so that every bloom can be seen. A wedge of wood put under the back of each pot will serve greatly to effect this, especially if applied to the back row; but the wedge should not be so thick as to give the plants a leaning-forward appearance, but just enough to show off the plants and blooms to perfection. The colours are worthy of some attention in arranging. Two scarlets, or two crimsons, should not be placed together, neither should two light-coloured ones be in juxtaposition. The Pelargonium produces plenty of choice in shades of colour to arrange them so as to have a very pleasing effect. Deep colours set off each other very beautifully; as, for instance, a glowing crimson-scarlet, like *Turner's Magnet*, is greatly enhanced in colour if placed next to such a bright pink-red as *Gaines's Salamander*, and the colour of that is brightened if placed next to such a

clear white as *Arnold's Virgin Queen*; next to that pure colour, one with a deep purple, such as *Alonzo*, adds greatly to the beauty of both. These examples will be sufficient to guide the amateur in arranging the colours of his blooms to the greatest advantage.

Mode of Conveyance.—The best conveyance for large plants is a wide, close-covered spring van or vans, with four wheels each. In this place a layer nine inches thick of coal-ashes, just moist enough not to be dusty, and not so wet as to cling to or dirty the pots. Set each plant close to the bottom of the van, and do not let them touch each other. Some place a long strand of mat round each plant, drawing the branches closer together, in order to get more plants into the van; but this is very injudicious, as the blooms then rub against each other, and are disfigured thereby. It is better and safer, and more economical in the end, to have, rather than crowd them, an extra van if one will not hold the collection. As each plant is placed in the van, let the packer press the ashes firmly to the pot, to prevent it slipping out of its place in going up or coming down a hill. The driver should be a careful, attentive man, and keep his eyes constantly upon the road during the journey. He should, if possible, avoid every loose stone or deep hole, in order to keep the plants steady, and shake the blooms as little as possible; a constant attention to this point will save the plants many a jolt, and bring them safely to their destination. The Pelargonium, with moderate care, may be conveyed safely a great distance; in proof of which I need only mention that the Messrs. Veitch, of Exeter, have sent them all the way from that place to London, brought them safe and fresh, and taken a prize with their collection.

I have now gone through the whole course of Pelargonium culture as an exhibition plant. I shall, in my next paper on this subject, give, as proposed at page 365, a list of the best varieties for 1853.

T. APPLEBY.

PRESERVATIVE WALLS.

(Continued from page 462.)

LIST OF SUITABLE PLANTS.

PITTIOSPORUM TOBIRA (*Tobira Pittosporum*).—An evergreen, slow-growing, handsome-foliaged shrub, with stalkless clusters of pure white sweet-scented flowers.

PITTIOSPORUM UNDULATUM (*Wavy-leaved Pittosporum*).—The leaves of this species are longer and thinner than the preceding, and besides this, they are undulated, that is, parts of the leaves rise up, and the other parts sink down, giving it the appearance of the waves of the sea; hence its specific name. The flowers are produced in loose panicles, and are white and green in colour. Like the *P. tobira*, they are sweet-scented.

These two species are both evergreen and hardy enough to bear our winters against a cold wall, if sheltered with a mat in severe weather.

PUNICA GRANATUM (*The Pomegranate*).—This well-known shrub is not hardy, excepting against a wall. The flowers are large, and of a rich scarlet-colour. They are produced on small twigs; hence, in pruning them, a large quantity of these twigs should be left on the branches. The flower-buds are very beautiful, even before the flowers expand. There are several varieties, all distinguished by variations in colour; but the original species is by far the finest; the double red being an exception—it is still more beautiful. In the North, this fine tree requires protection to bloom it well; yet it will not bloom well in a greenhouse, probably because it does not obtain there a sufficient amount of rest during winter. The best bloomed plant I ever saw was planted against a west wall, in a stable-yard that was paved close up to the stem; the soil was thin and poor,

but very dry, conditions that most likely were favourable to the production of these beautiful flowers. I never saw it fruit in this country; but I have no doubt it would produce its beautiful fruit in a preservative.

RAPHIOLEPIS.—A genus of shrubs, with evergreen foliage and handsome flowers. All from China, and hardy enough to bear our winters on a glass-covered wall, without heat. They are very little known, though most of them have been introduced more than twenty years ago. The species are, *R. indica*, *R. phænostemon*, brown stamened. *R. rubrum*, red, and *R. salicifolia*, willow-leaved.

RHODODENDRON ARBOREUM (*The Tree Rhododendron*).—Though this fine species is strictly a conservatory plant; yet it may be planted with a good effect against a wall. It is so nearly hardy, that no artificial heat is required to protect it. It flowers so early, that the blossoms are always injured by late frosts, if they are cultivated in the open air. The splendid trusses of bloom of a dazzling scarlet, bright crimson, rich purple, and pure white, render all the varieties desirable plants for a glass-covered wall. They all require a large mixture of sandy peat amongst the soil.

RHODODENDRON CAMPANULATUM (*Bell-flowered Rhododendron*).—This distinct species is not quite hardy, and though a slow grower is well deserving a place against a sheltered wall. The flowers are of a pleasing pink hue, spotted with brownish crimson.

RHODODENDRON GIBSONII (*Mr. Gibson's Rhododendron*, sometimes called *R. formosum*).—It is a fast growing species, with foliage like an Azalea. The flowers are very large, of a blush-white colour, and are generally produced in pairs, from the axils of the leaves, towards the ends of the shoots. They are slightly perfumed. It requires protection from frost. It is a most beautiful species, and should be grown in every collection.

ROSA (*The Rose*).—If the preservative is on a large scale, a few of the best Tea Roses and hybrid China Roses may be planted with good effect; they will bloom early and late, and will not be injured by heavy rains, or late and early frosts.

SCHOTIA SPECIOSA (*Showy Schotia*).—A plant from the Cape of Good Hope; very seldom seen in flower; but, when planted against a wall covered with glass, it will bloom freely when old. The flowers are produced at the ends of the strong short shoots: hence these only should be left on the tree; all weak ones should be pruned away.

SIPHOCAMPYLOS BETULÆFOLIUS (*Birch-leaved Siphocampylos*).—It is not generally known that this handsome free-flowering plant is generally hardy, as is also *S. bicolor*. They are both worthy of a place against a glass-covered wall, on account of their pretty flowers, which are produced all the summer. In such a situation they grow much finer than in a pot. The first has red flowers, and the other red and yellow blooms.

SOLLYA.—A genus of half-hardy climbers. I do not generally advise the planting of climbers against a wall of this description, because they would overrun more valuable plants; but this genus is an exception. They are twiners, and will run up and twist round a wire, or wires, which should be placed behind the plants for that purpose. Their foliage is small, and, therefore, will not shade other plants; and their flowers are of a pleasing blue colour, and produced profusely, the whole length of the shoots. The species suitable are *S. angustifolia* (*Narrow-leaved*); *S. heterophylla* (*Various-leaved*); *S. linearis* (*Narrow-leaved*); and *S. salicifolia* (*Willow-leaved*). If these four species are procured, and planted at equal distances, and upright wire rods fixed a little distance from the wall, for the shoots to twine round, they will produce a good effect.

STRANVESIA GLAUDESCENS (*Grey Stranvesia*).—A rare, and almost evergreen, shrub from Nepal, with white

flowers, like those of the Apple. It is named in honour of the Hon. W. F. Strangways, an assiduous cultivator of hardy flowers in the open air of Dorset. This plant will live and flower against a wall covered with glass, without heat.

SUTHERLANDIA FRUTESCENS (Shrubby Sutherlandia).—A charming, quick-growing shrub, with pinnate leaves, and rich scarlet flowers. It is a very ancient plant, having been introduced from the Cape more than two hundred years ago.

SUTHERLANDIA MICROPHYLLA (Small-leaved Sutherlandia).—This is of more recent introduction, and is equally, if not more beautiful than the preceding. Both will bear a moderate degree of frost without injury, but it is safer to plant them against a wall, and protect them with mats through severe frost.

T. APPLEBY.

(To be continued.)

ECONOMICAL ARRANGEMENT OF KITCHEN GARDEN CROPS.

As the frosts we had towards the end of February, and subsequently, have, in most cases, destroyed the early crops of *Peas* (we mean those sown in November), which promised to be early, and which the unusual mild weather of the usual winter months drew up to an improper length, the successional crops, which are those sown a little before Christmas, will now be the most forward, unless some portion of the other was protected by something more than mere boughs. It is, therefore, important to allow the most forward all the advantages that can be given them, in order to hasten their bearing. Sticks of a suitable kind must be applied; and any small crop, as Spinach, &c., that may be occupying a temporary place between the rows, must be removed before it does any harm by running to seed, &c.; in fact, it would be better to dispense with such crops at this important period, for the welfare of the *Peas* ought not to be sacrificed for trifles. Supposing there not to have been any such crop, the ground should be frequently stirred between the rows, in order for it to benefit by the action of the atmosphere; and the growing crop to be treated with those subtle, yet highly beneficial, gases, which newly turned-up ground gives off in such abundance. These, and other encouraging operations, will hasten on the crop, so that though it cannot be expected that those sown in December will be fit to gather on the same day of the month as those of former years sown in November, yet, if the season prove at all propitious, they will not be many days behind; and, most likely, will fully equal their more early-sown competitors in the abundance of the crop—other things considered; but, as *Peas* for after-use must also be sown, it is proper here to take a view of the many kinds we have to choose from.

It is almost a pity that the attempts to reduce our seed-lists within moderate bounds has not met that response from buyers which it ought to do. The thirst for novelty seems so deeply implanted in our nature, and we are so easily made the victims of our credulity, that no sooner does an unscrupulous dealer announce an article, say an "Early Pea," which comes in a full week before the most forward one known, that we never stop to enquire whether this "Nonsuch" be a really distinct article, and proving so by its growth, or bearing, or some other point; or whether the distinction consists of some clever piece of legerdemain, whereby a bag of *Charltons* can be converted into half-a-dozen first-rate early sorts, each a week or ten days earlier than any other known. This latter system of multiplying kinds is attributable to that itching desire

for novelty, which, as we have just said, is a common feature in the horticultural world; neither do we see any just reason for checking it than a caution as to whom they deal with; as a respectable tradesman is unwilling to risk his reputation by sending out an article under his own sanction, without having some knowledge of its qualification as likely to serve the purpose intended. *Peas* are, however, some exception to this rule, because the common kinds (which, it is feared, forms the "stock" of many new-fashioned-named ones,) are generally good, the *Early Frame, Kent,* and *Charlton* being all good *Peas*, and each capable of producing good, useful crops under ordinary circumstances; so that, in reality, the loss is not so great in this way as in many other instances where an old variety is puffed forward under a new name.

Leaving, therefore, such things to purify themselves, it behoves the amateur, and those of small means, to plant a good useful variety of *Pea* for his second or principal crop, in place of an uncertain or novel one—and as our seedsmen's lists present a sufficient array of names, classed in accordance with their height and other peculiarities, there will be no difficulty in the amateur finding out which of them is likely to suit his purpose best; but, if he should find any difficulty, or wish for advice, we may say that the *British Queen,* and *Champion of England* are both good *Peas*—the former the tallest; and as they bear well, and are generally esteemed at table, their qualifications are all that are wanted. Supposing, therefore, that these kinds were determined on, and that ground for the purpose of growing them on was scarce, and ought to be made the most of—we would look round and arrange the general cropping, so as to have *Peas* planted in some place where an after-crop could also be introduced while they were still growing, which after-crop would, at the time the *Peas* were removed, require all the power for its own use. Now, this kind of "remove" system is applicable to many things, as well as that which we are now especially speaking of; but, as our remarks bear more particularly to that, we may say, that if, after looking over the ground at disposal, and considering where the principal crop of *Celery, Winter Brocoli,* and *Greens* are to be planted, arrangements might be made with some of these, whereby *Peas* may be grown on the same spot as well. If *Celery* trenches were dug out, and a little more than the usual width allowed for ridge, *Peas* might be sown on these; or, it might be, *Potatoes* planted; and at the proper time, the *Celery,* as the legitimate crop, might be planted also; which, though it would not progress perhaps so well as if without the *Peas,* yet it would have a sufficient season left after the other was removed; and consequently would, in most cases, recover its proper position ere winter came on. The various members of the winter and late spring *Brocoli,* &c., offer still better chances for *Peas* being planted between them; and in fact, where ground is scarce, and everything has to be made of it, it becomes a matter of importance to take as many crops of it as possible; only, it must be borne in mind, that when the *Peas* or other temporary crop be planted, the ground should be measured, so as to be available for the after-crop, without eventually showing that recourse had been had to such an economical mode of cultivation; for that purpose, therefore, rows of *Peas* should be six or eight feet apart, in order to allow three or four rows of *Brocoli,* and at two feet distance—and though it is not common to allow *Celery* so much room between rows, yet, where advisable, a row of *Peas* should occupy only every other ridge; or, it may be, that a wide cross ridge or trench may be adopted, and then there is abundant room for both *Peas* and *Celery.* Should, however, none of these modes be approved of, *Peas* may be sown in rows on the open ground, about the same number of feet apart

that they are in height; this forms a very good criterion for the inexperienced, and but little is gained by having them closer. On the contrary, the crop is certainly less on a given space of ground by their being crowded together.

Sundries.—Examine the various pots or pans of *Chilies*, *Tomatos*, *Vegetable Marrow*, and other plants which it is common to raise in hotbeds in spring, to plant out when confirmed summer weather arrives; these should be potted off, and re-potted as occasion requires, and more sown if needs be. Ridge *Cucumbers* should also be sown in pots plunged in heat, and the same said of some of the more tender sweet herbs, as *Busil*, *Sweet Marjoram*, &c., &c.; and, if not sown before, a few seeds of *Indian Corn* may be put in by those who have a wish to see this singular addition to our cereals, as it is likely to arrive sooner at perfection, and that of a more superior kind, if raised in the first instance in pots; but then it must not be allowed to become "pot-bound;" otherwise it is stunted in its growth to such a degree as to cripple its future efforts.

Examine the beds in which *Cucumbers* and *Melons* are growing, and maintain a brisk, yet steady heat; and more of each kind may be sown, if required; potting-off, in due course, all that require it. Finish the planting of *Potatoes* on such grounds as the adverse weather rendered necessary to postpone; and plant *Beans* and other things on the same soils. Sow a few early *Turnips* on some sheltered border facing the south, which, however, must be protected at nights, after they come up, otherwise a very slight frost is said to make them run to seed afterwards. *Lettuce* may also be sown, both of the *Cos* and *Cabbage* kinds; and the same may be said of *Cauliflowers*, and, of course, *Spinach* must be sown to meet the demands at the proper time; while *Carrots* may be delayed a week or so longer, if the season be adverse; as, likewise, may *Red Beet*, *Salsafy*, and *Scorzoneria*; but *Parsnips*, if not sown before, ought to be done without delay; and such things as *Radishes*, and similar small crops must be sown, as the wants of the family require other things in the same way. And the ordinary routine-work of digging vacant ground, preparing hot dung, composts, &c., attended to in due course; and though last, not least, that proper regard paid to neatness in all things, without which good cultivation and management are only half accomplished, while its presence gives that finish to objects, which brings them considerably nearer to that position we advise all to point to—*i. e.* "perfection." J. ROBSON.

AGRICULTURAL OPERATIONS FOR MARCH.

DRAINING being one of the most important operations of the farming business, upon all those soils which are damaged by a superabundance of water, I beg to call the attention of parties intending to drain their land to the fact, that the month of March is the best time of the year for setting out the work for drainers.

The land about this period generally begins to dry—appearing white on the surface; and, after the heavy rains of the winter months, those fields, or parts of fields, which are naturally dry, will thus first evince the effects of dry weather; and, on the other hand, the land which is naturally wet, or which is affected by springs rising to the surface, will point out, by the damp, dark, and undried appearance of the surface, the exact position of such spots as require to be drained. This will give the drainer an opportunity of planning his work with the greatest nicety and precision, and enable him to work with the greatest economy in the outlay, as well as to effect the most perfect drainage of the soil.

Those soils in which gravel or sand predominate will be found to suffer most from springs, and generally require

only partial drainage, more particularly where the land is hilly, and irregular in character, alternating between sand, gravel, and clay. It will be found that draining operations upon the above-named soils can always be most advantageously laid out where the land is under tillage, having a fallow surface; for the first dry weather in spring will exhibit, as it were, a map, whereon the wet and dry portions of the field will be distinctly marked.

Upon level land of uniform nature and quality, where draining is required, it may be considered comparatively unimportant when the work is set out, because such lands generally require to be drained at nearly equal depth and distance between the drains; indeed, upon soils requiring thorough draining, as it is termed, the work may be laid out and executed either with a turf or fallow surface, and at almost any period of the year with equal advantage.

The foregoing observations are intended only to draw attention to the best season for laying out draining work; but it is intended, at a future time, to enlarge upon the subject, by shewing the best depth and distance for placing drains, according to the nature of the land, and the best materials to be used for effecting permanent and entire drainage of different soils.

OAT-SOWING.—The season has now arrived when the management and preparation of the land intended to be sown with Oats must engage our attention. No doubt the land has all been ploughed, where it is intended for the oat crop either to follow wheat or grass lea of last year—if not, the sooner it is ploughed the better, otherwise the slight frosts and drying winds peculiar to the month of March will not produce the usual beneficial effects in pulverising and chastening the soil; neither will it be possible to have the seed sown, as it should be, before the commencement of the month of April. All kinds of Oats will be found to yield better, both as regards quantity and quality, when sown in the March month.

The most difficult operation is the preparation of land for the oat crop, after feeding turnips on the land with sheep, particularly upon loamy land, which has been trodden during wet weather. It is a common practice to plough the land, in such a case, immediately after the sheep have left the field, be it ever so heavy, and after a short time has elapsed to plough the second time, and then sow the seed; but the most advantageous plan, and the least expensive, will be found in allowing the land to remain until it is intended to be sown (which will give it time to get firm and mellow), then to plough a moderate depth—say three inches—sow the seed, harrow and roll the land perfectly fine, either the same day as ploughed, or the next day, as may be most convenient. In this manner a fine tilth will be insured, favourable both for the Oats and Clover seeds, which are usually sown at the same time. Oats generally succeed best sown broadcast: about four bushels per acre will be sufficient seed, where the land is in good cultivation.

The *Wireworm* is a great enemy to the Oat crop, when sown after Turnips eaten off by sheep; it is, therefore, a good plan to sow half-a-bushel of Barley per acre with the Oats, when intended for home consumption, as it improves the produce, both in quantity and value, and goes far to insure a plant of corn when attacked by the wireworm, for it often happens that the Oats are eaten by the worm and the Barley left almost untouched. The Barley grows more rapidly than the Oats, and thus insures a crop. The best kind of Oats for sowing on good loamy or strong soils, are the *Black Tartarian*, being good for a crop, and of fair quality, usually weighing 36 lbs. to 38 lbs. per bushel. There are also other advantages attached to the growth of these Oats—they do well upon hilly and exposed situations, and, being firmly set, they do not readily shed their seed, or whip off with the wind at harvest; they will also stand longer without loss, in case the harvest is delayed by the pressure of other work, or the scarcity of labour.

The *White Scotch Potato* Oats, and the *Black Siberian* kind, will be found well adapted for any dry soils in good condition, and upon level land, not much exposed to wind; they often prove very productive, and of excellent quality, weighing from 38 lbs. to 42 lbs. per bushel, but they always require to be cut before they are quite ripe, and the harvest cannot be delayed without risk and loss.

When manure is required for the Oat crop, the best kind is guano. It is wonderful the effect of an application of two hundredweight of Peruvian guano per acre, harrowed in with the seed. The writer has seen the crop increased by this application from six quarters to nine quarters per acre, with an increase in the value of straw sufficient to pay the cost of the manure, thus leaving three quarters of corn per acre as the profit.*—J. BLUNDELL.

ALLOTMENT FARMING—APRIL.

WE have once more arrived at that delightful period of spring, when a peculiar buoyancy of spirit gives elasticity to the step and an energy to the arm very different from that of our dull winter months. The allotment holder, and the gardening cottager, partake of this movement; and, like the bee, feel it necessary to bestir themselves with all possible activity, in order to provide, not only for daily sustenance, but stores for another winter. The past season has been so unfavourable to the due amelioration of the soil that it is to be feared many soils are in but indifferent order. Those, however, who took my advice before the last severe and unusual frost, to dig deep and ridge their land, will now reap the benefit of that advice. We adopted that practice at the end of the rainy season with several plots, in anticipation of late frosts, and our land, at this period (March 15th), is in splendid order. We have been sowing Onions, Parsnips, Horn Carrots, Peas, Beans; and planting Raspberries, Strawberries, Sea Kale, &c.; and we never got crops in more pleasantly. But the whole was ridged, and much of it trenched—some three spades deep, bringing up a little of the subsoil, a practice found to succeed on old and hard-worn garden soil. I will now proceed to consider the root-crops—at all times the most important. A poor man may manage tolerably well during summer and autumn with "what he can catch," with trifling extras, which may be called "stolen crops," to use a farmer's phrase; but in what position would he be in the following winter and early spring, if without roots; and Potatoes, may be, four shillings a bushel, as they are now in these parts? Our townsmen who earn a pound per week, or more, can, perhaps, afford to purchase them liberally: not so the ordinary labourer at ten shillings per week, with oftentimes a family of nearly half a score children. But how the case becomes altered, if the latter character, by great industry and economy, is enabled to sell half a score bushels of Potatoes at that price, which I have known many to do, by growing and using freely those other excellent roots, the Carrot and Parsnip, and by using boiled Peas as part diet. By such means he may soon cover the rent of his plot, and all the rest is clear profit; and, in addition, he has had no temptation to squat in beer-houses.

Many crops are by this time in the ground—such as Onions, Peas, Broad Beans, &c.; and such being the case, let us ask about *Potatoes* first. Doubtless, some early ones have been planted, and now the sooner the main crops are in, if not done, the better. No planting after the beginning of April for me. I may here observe on the peculiar habits of the *Ash-leaved Kidney*. My remarks will, perhaps, astonish, if not alarm, some; but it matters not; my duty must be performed: and what has been proved by sound experience, may surely be spoken boldly. For many years I used to plant this invaluable Potato in February, and so, indeed, did most of our farming folks; but, by degrees, we were surprised to find a certain neighbour planting later every year; and as he did so, each year the more excelling, both in earliness and produce, until at last his planting time reached the first week in April.

I must confess that this made me blush to think how it could be, and that a man not bred to the business, and whose other gardening I could afford to think lightly of, should thus discover a practice, which much real experience, backed by some scientific knowledge, had failed to perceive;

* Both nitrate of soda, and sulphate of ammonia, applied as a top-dressing, also act very favourably for this crop, either in moderate quantities, such as one hundredweight of either per acre, or in still smaller proportions combined with guano. If the existence of wireworm is suspected, it is well to drill in with the seed two hundredweight of rape cake per acre, as this is more effectual in destroying these pests than any other application.

but so it was. This man keeps his seed kidneys in baskets, hampers, &c., until March, in a dry room, where frost cannot enter; they are thrown on the floor of a shed for two or three weeks, after getting them up for seed, and there they become greenish, and thence are transferred to the hampers in the loft. About the end of February they are placed out singly on the floor, over a warm stable, and here, by the end of March, they become sprouted—the sprouts nearly two inches long, and very stout. In the very opening of April, they are carefully planted on sloping warm banks, formed expressly, and well manured, and in the first week of May they burst through the soil, robust as strong Asparagus heads. Now, it is of no use desiring to have Potatoes above ground until May arrives, unless they are protected; earlier may do for a speculation, but there is little safety.

I must now return to the *main crops of Potatoes*. I advise those about to plant to use very old manure where really requisite, and but a moderate amount of it. It is quite certain that disease will be better avoided by planting on very poor soils; but this is not the way to obtain a profitable crop. We have, this last year, found the crops of Potatoes, in many instances, so small as to be almost unfit for table purposes; for in Cheshire, all Potatoes are pared before cooking, and when they are small and the eye-holes happen to be somewhat deep, the Potato is reduced to a most inconvenient size, and occupies too much time in paring. This smallness arises from the use of less manure than formerly, together with the use of *whole seed*; a practice already beginning to be abandoned by many, for the reasons stated. I, for one, intend returning to cut sets this season for the cooking Potatoes; but then, I shall certainly grow SPECIALLY FOR SEED from *whole* Potatoes, in unmanured ground.

It is, indeed, a pity that the latter practice is not more general; for by it, I am persuaded, the constitution of the root would be improved. My practice, in this respect, is to select whole Potatoes, well formed, nearly as large as a pullet's egg, with *rough skins*; and to plant them on *raised* land of poor character, about nine inches square apart. Thus treated, they produce many Potatoes, pretty equal in size, and about as large as the seed itself. These, then, are excellent for planting whole, on pretty good soil, for a full crop, taking care to breed the following year's stock from the pick of them in like manure. We find the York Regents, the Lancashire Kemps, the Radical, and the Pink eye, the most useful kinds, under present circumstances.

CARROTS.—Preparation should be made to get in this valuable root soon after the middle of the month. The large kinds, as the Altringham, must have the soil deep and well-broken. They require a generous soil, but by no means raw manure near the surface. If the ground is dug two good spades in depth, a good coat of half-rotten manure may be spread on the surface, and dug in with a full spit, *not pared in*; the second spit will, of course, be clean soil: thus the surface will not be rich, and it will be found good practice to apply a mixed compost in the drills. Old leaf soil, or mellow, dark material, having some Peruvian guano, soot, &c., stirred amongst it, and thoroughly divided, may be used: this will establish the young plant, and get it out of the way of slugs, their greatest enemies; and by the time the compost is exhausted the tap root will be reaching the manure. The large Carrots, may be in drills, about fourteen inches apart, and the Carrots, when up, thinned finally to about five inches; the final thinning, however, must be delayed as long as possible for fear of the grub. Horn Carrots may be sown in beds four feet in width; shallow soil will do, but it must be good; these are not so liable to the grub, and they will produce a good crop if only three inches apart all over the bed.

MANGOLD.—This sown about the third week, the ground well-worked and deep; some manure added, by all means, and, as it is known to be partial to salt, it will be found a benefit to apply a thin dressing; this we would strew over the manure before spreading it. I used soot and salt last year, and had a splendid crop; three barrows of soot to one of salt, well blended, and applied as before observed; the manure being entirely from the pigs and the cow; this dressing was applied nearly half-an-inch in thickness all over the manure. Sow in drills, at from twenty to twenty-four inches, in patches (of three or four seeds in patch), about

eight inches apart: these patches finally reduced to single plants.

SWEDE TURNIPS.—Great complaints existed, last summer, in various parts, of the ravages of the mildew in Swedes; and there can be little doubt that early sown ones are more liable to it than those which are late. The general practice has been to sow about the middle of April; but, unless the soil is in first-rate order, I would advise the second week in May, in preference. The mildew is, doubtless, brought on by stagnation at the root, and *drought is frequently the cause*. Swedes love a well-worked, well-manured soil; the latter in an *equable and moist* state and half rotten. Those who plough or dig-in manure in a lumpy and husky condition, cannot expect to escape the mildew. Let your soil, therefore, be deeply dug and thoroughly broken; and see that the *manure be divided and very moist*. People who leave their dunghills scattered about during the summer, losing half their strength, and becoming baked clots, cannot hope for success. Too many neglect to turn their midden; this is a most important matter, and should be done every September, the whole well-divided, mixed, and then *soiled over*. Swedes may be sown in drills about eighteen to twenty inches apart, and thinly; the plants *lightly thinned* at first, and finally, after all danger of fly is over, to seven or eight inches.

COMMON TURNIPS.—The Stone, Orange Jelly, or Dutch, sown in the first week, will be very useful to the poor man's wife in June and July; a few, however, ought to suffice, as they should not be allowed to occupy ground at the *expense of keeping roots*, or, indeed, of other crops, such as Cabbage. No more Common Turnips need be sown until July in allotments, unless some special reason justifies the proceeding.

ONIONS.—These, if not sown, may yet be sown in the first week; let them be sown in beds thrown up nearly a foot, above the ground level, in order to get them ripened betimes. The ground should be good from preceding manuring. Those sown in the beginning of March will require to be weeded, thinned, &c., at the end of this month.

PARSNIPS will also require weeding and thinning at the end:—Thin out, finally, to about five or six inches. If requisite, they may be sown at the beginning; they like, however, a long summer.

PEAS.—The Imperial or Prussian, two of the best for this purpose, may be sown in the early part of April, for a full crop; another sowing, if particularly desirable, may be made in the very end of the month; after this, no room ought possibly to be spared for this luxury.

BROAD BEANS.—Some long beds may be planted in the beginning, for the last; those up should be hoed by side culture.

LETTUCE.—A little of the Ady's Cos may be sown in the first week, and again in the last: these *head well without tying*, and are both useful and profitable: we would not sow more until after Midsummer. Indeed, although a good thing, they may not be a primary consideration; but rather, what has been called "*stolen crops*." If the cottager has more Lettuce than his family can consume he may let them run to seed, if not in the way; when nearly a yard high, they will prove excellent food for the pig.

SPINACH.—A little of round kind may be put in (as a stolen crop), in the first week; few small gardeners, however, care for it.

SCARLET RUNNERS.—This is an important crop; no small or large garden should be without them; they may be sown in the second week. Various plans of supporting them are in practice; some run them up with stretched strings, some stake them as peas, &c., but if the cultivator is short of time and stakes, they will form a bush unsupported, merely by frequently pinching off the leading shoots. They succeed well on stakes three feet high, by this practice; they require rich soil, and delight in *moisture* in hot weather.

CABBAGE WORTS.—Cabbages sown once a month until the middle of August. Savoys, Brussels Sprouts, Green Kale, sown in the first week, and again in the last, will meet every demand. If Brocolis are required, sow a few Autumn kinds at the end of the month, and late Spring kinds towards the middle.

PROVIDE FOR BLANKS.—A most important affair: Carrots may grub, so may Onions; the fly may take the Turnips, and even Mangold. Let every man provide for the worst.

A good bed of Swedes to transplant, sown in the second week in May, and the monthly sowing of Cabbages, are the two surest crops for this purpose; and as to Swedes, if they can be produced, they can be exchanged for those other roots which have proved deficient. And herein lies the policy of sowing a few Cabbages monthly; plants are always at hand if needed, and the seed is no consideration. Indeed, I would not plant *any special plot* of ground with Cabbage, but ever depend on a few from amongst other cropping.

Now let us observe, that as the days are long, our allotment men will take care that business does not overtake them. There is a saying amongst race-course people, that, "a good start is half the race," and, indeed, it is particularly so in gardening and farming. If a man suffer himself to be beaten in April, I will engage that he never recovers the whole summer. There is now no time for beer-shops, no chance for lounging: he it is who is afraid of wasting a minute, who shall be first in the autumn; and who shall have the most pleasant remembrances over his Christmas fire.

Those of our readers who have had a breeding sow will find it highly remunerating this spring. Pork is now selling in the carcase at 6d. per lb., and Bacon is 8d. and 9d., at least in these parts. I have lived here twenty five years, and cannot remember it ever being so high before. The cottager's Cabbage Worts of every kind will now be running to seed fast; and a good pig caterer will collect almost daily from such sources. This will help to keep the wife's hands out of the meal tub, which makes the bacon oftentimes too expensive. Let the pig-keeper, too, be sure to keep his animals clean; washing out the floors of the outlet weekly, and giving his pig a fresh *dry bed* three times a week, if possible. This is the way, also, to get a good manure heap. They have a saying in this county, that "a good bed is half meat."

R. ERRINGTON.

THE APIARIAN'S CALENDAR.—APRIL.

By J. H. Payne, Esq., Author of "The Bee-Keeper's Guide," &c.

THE SEASON.—As might be expected, the season has been fatal to vast numbers of stocks in this neighbourhood (Bury St. Edmunds). I think one stock out of every three has perished, and unless regular and judicious feeding is attended to, greater losses will still be experienced. Barley-sugar is certainly the cheapest, as well as the safest, for spring-feeding, and is supplied with much less trouble than any other kind of food.

HIVES.—It is now quite time to have a supply of hives for the coming season, where new ones are required, and where old ones are to be used, to have them well cleaned. It is also a good time to paint those hives that are occupied; it will greatly improve their appearance, as well as tend to preserve them. A well-made hive, painted before the bees are put into it, and once every other year afterwards, will last uninjured for upwards of twenty years; indeed, I have one at the present time that has stood even much longer. They may be painted after six o'clock in the morning without danger to the operator, or inconvenience to the bees; of course stopping the mouth of the hive for the time. I find stone or straw-colour to be the best, as absorbing less heat than green or any dark colour. Perhaps, on this account, white would be best, but the strong-reflecting light from it is very objectionable.

GUIDE-COMBS.—Small pieces of white comb, to be used as guide-combs for glasses and bee-hives, will be found very useful in facilitating the commencement of working in them, and should be carefully preserved for that purpose.

BEARDED POLANDS.

I have read, without any surprise, the article by Dr. Horner, on the subject of the Poland Fowls with beards, and I rely on your fairness and courtesy for the admission to your columns of my opinions, as a votary, if not an admirer, of the beardless variety. In giving these opinions, and supporting them with such arguments as present themselves, I disclaim any other view than the elucidation of truth.

The whole affair lies in a nutshell.

Dr. Horner has arrived *per sultum* at "the true Polands." I say *per sultum*, because he has not condescended to inform us by what process of reasoning, unless assertion and italics are with him in place of argument, he has discovered that these "dashing debonairs," and all sorts of sparkling epithet-wearing birds, are Polands, or Polish, at all. I contend, and I challenge him to prove me in error, that they have just as much right to be called Polanders, as Zealanders or Esquimaux. Not to imitate the Doctor in complacency of assertion, I will just bespeak your attention, and that of your readers, to the opinions of authors, who have ten times the experience, and fifty times the learning, that either he or I can pretend to. Mowbray says,—“The Poland Fowls, as they are generally called, were chiefly imported from Holland.” And he adds, in a subsequent paragraph, “Besides the Polanders, there is a small variety now imported from Holland, called Every-day-hens, which are everlasting layers.” I desire this juxtaposition of these two varieties may be had in remembrance. Dr. John C. Bennett, of Boston, U.S., a very intelligent and experienced breeder of poultry, cannot see a trace, or wind a scent, of the origin of Polish Fowls, and contents himself with the confession of his faith, that the breed “is quite unknown in Poland.” With him goes Dickson, whose words the Yankee Doctor quotes to enunciate all he knows, or has to say, upon the subject. Micaiah Cook, who publishes from New York, under his arrangement, having a variety “*Cristatus*,” says,—“Of this there are several races: the *Poland*, which is said to have been first introduced into Holland from the East, and from thence distributed through Europe and America.” Knight, in his admirable work, the “Farmer’s Library,” has it thus,—“Fanciers discriminate between this breed and the Spangled Hamburg, although by many they are confounded together.” In thus declaring himself, he has *totidem verbis* acknowledged his present ignorance of his subject, even if he had not stumbled in the outset of his next sentence—“Both are crested.” Some unconscious fumbling of the truth has passed from his inkstand to his paper in what he has put forth concerning the black Poland Fowl. “This variety is, by some, called the Paduan Fowl; but why these appellations should be given *we do not know*.” If you can spare me a few of Dr. Horner’s argumentative italics, and would put “*we do not know*” in that type, it might serve to put prominently forward this author’s acknowledgment of his full share of the universal ignorance of the origin, or source, of the so-called Polish Fowl, in all its varieties. I beg to point attention to the very important admission that not the Paduan only, but the Polish appellation—“these appellations”—are ignored.

It may occur to your readers, that the very fact of these birds being so generally known as Polish or Poland fowls is an argument as yet unanswered—that there must be some reasons (and what can they be?) for this epithet. Potent reasons cannot be assigned; the whole field is one of conjecture. Dr. Bennett gives his opinion again in Dickson’s words, that the breed of Polanders “takes its name from some resemblance having been fancied between its tufted crest and the square-spreading crown of the feathered caps worn by the Polish soldiers.” The Rev. Edmund Saul Dixon, our *facile princeps* of authorities upon all matters bearing upon these interesting subjects, and whose authority I have purposely reserved to this point, says of the Poland, or Polish fowl, “Certain fowls with top-knots are called by the above names. Whence the title was derived I have endeavoured in vain to trace.” I must refer the reader to his able and scholar-like work on “Ornamental and Domestic Poultry” for his conjectures on the origin of the appellation, merely observing, that his hypothesis of the Polish disease, the *Plica Polonica*, in allusion to the top-knot, has suggested the idea. He subjoins, that the birds figured by Aldrovandus as the Paduan fowls are what we now call Polanders.

From those admissions of the obscurity of the origin of the breed under discussion, we might infer that some Dutch Sebright has elaborated a variety, and buried his secret with him in his grave. The juxtaposition, and proneness to confound the races, of these pseudo-Poles and Hamburgs might suggest probabilities; but with probabilities, in such cases, we have little sympathy. The absence of all proof of genuine origin leaves the necessity for our

belief that the variety is entirely an artificial one, and the crying-back of the breed opens the way to conjecture. It is, therefore, no longer a contest for “the true Poland,” much less for “the true Bearded Poland.” The question resolves itself into a mere matter of taste. It would be presumption in any one to decry a breed which finds some, not many admirers. I confess the *Plica Polonica* is always uppermost in my thoughts, whenever I behold the most admired specimens. Their “remarkably voluminous and profusely-hackled necks” are, to my taste, deformities, and I can only see in them Tudor chimnies, which, however interesting to the antiquarian, are not necessary for the evolution of smoke. The top-knots are very strange, doubtless; but they are only very strange. They blind and irritate the eyes of the birds; and I must fully agree with Micaiah Cook that “they should be sometimes clipped.”

If such be my opinion of the beardless variety of the barbarian rarity, I cannot speak without extreme distaste. If, as Dixon supposes, climate shall have added them, and they be necessary in ours, why that is sufficient reason with me for rejecting a breed so necessarily odious. I have had top-knotted Ducks, which have occasionally pulled-down their Polish caps under their chin; and also top-knotted common fowls, which have been odiously luxuriant in this provision. Have I kept them? How long? Till they were fit for the spit, and no longer. In parts of Switzerland, Goiters are plentiful and cherished; but I neither wish for, nor reverence a Goiter. We know that farmers, gentlemen’s butlers, and housekeepers, wear a large proportion of their cheeks around their jowl and chin: but is this a feature to be admired? As soon shall we admire a Venus, or an Apollo, whose calves have slipped down to their ankles.

To my own satisfaction, and I trust that of all unbiased readers, I have proved, without a fountain of italics, and by the admission of the learned rather than mine own unsupported *dictum*, that a Polish breed, like Poland itself, is NOT, and, unlike Poland itself, never was. As to the matter of TASTE, the only authority on the subject, and the only arbiter, I leave beards on birds, and goiters on girls, and amplification of ancles on Venuses and Apollos, to those who can admire them.—R. G. S. BROWNE, *Withycombe Cottage, Devon*.

JAPAN LILIES FOR GARDEN DECORATION

THE *Lilium lancifolium* being so deservedly popular, has attracted a great deal of attention, and its cultivation in pots, for display in the conservatory during the autumn, has been attended with the best results—health of foliage, vigour of growth, and richness and beauty of blossom. Notwithstanding its being scattered so widely through the country, the question of its *hardiness* is still a debateable matter. I shall not presume to give a definition of what is a *hardy plant*, I shall only say, that I understand by the term, any plant not liable to serious injury from the variable climate of this country. The *Lilium lancifolium*, unfortunately, from the experiments made here, will not come under that description; and I confess, that the question of its hardiness for cultivation in the open garden being still an unsettled question, would lead to the conclusion, that but little or no success has been attained in the matter.

Its early vegetation, starting into growth in March, leaves it liable to spring frosts, which destroy its foliage, leaving it disfigured through the summer, with spotted and decaying leaves; and the fact of its very late period of blooming, in the middle of September, exposing it to the almost certainty of frost at that time, are found, here, to be the chief causes of failure; and wetness during the period of *rest* is found to be injurious to the bulbs.

The foregoing remarks are founded upon experiments tried here upon its capabilities as “an out-of-doors” plant. E. Bouverie, Esq., my honoured employer, having a fine collection of these Lilies, was desirous to have some planted out, and, accordingly, a bed was prepared, the earth removed two feet deep, some *rubble* placed at the bottom, and refilled with a compost similar to that described in your number 233. Eight pots of good flowering-plants were carefully placed in it in the middle of February; the whole was covered with leaf mould to exclude frost. By the

latter end of March they had shot above ground. Empty flower-pots were placed over them when frost was expected; but, notwithstanding all the care bestowed upon them, the frost, at the end of April and beginning of May, injured the leaves, causing them to "spot" and decay. The plants grew pretty well throughout the summer, and "showed" flower early in September. A frost occurred (which killed back Dahlias), and prevented the blossoms coming to maturity. The stems were suffered to die down, and the bed was covered with dry "tan," to protect the bulbs from frost. The succeeding year a repetition took place of early growth, injury from frost, and spot on the leaf. Their period of flowering was as late as the preceding year, and the result being so unsatisfactory, they were fresh potted, and have since made good specimens by the management described in your last number.

To advance, or hasten, their period of blooming, appeared to me to be absolutely necessary, to secure a display of these Lilies in the open air. This is effected by removing them from their winter quarters early in January; starting them in any structure where there is a gentle warmth—greenhouse, pit, or vinery; encouraging their growth, without check, until all danger from frost is passed; and *phunging* them in suitable situations in the garden. Thus, a small circle cut in the turf, and sunk sufficiently deep to conceal the pot, has a very good effect, or a vacancy may be filled in an herbaceous bed. The plants will continue in flower for a month, and have a fine effect. I may mention, that in addition to the bed prepared above, two or three other plants were turned out in other places, and suffered to remain for the third year, but with the same ill-success.

And now, having stated the facts of the case, allow me to say, that I hope the present communication may have the effect of eliciting from your correspondents an account of their experience in the matter. The fact of the *hardy* nature of these Lilies is of importance, not alone, as your talented writer, Mr. Fish, suggests, to the *exhibitors* of this very useful and beautiful autumnal flower, but also to the *many* who are induced to begin acquaintance with it, by placing it in a situation unfavourable to its progress. When the evidence is summed-up, "treatment," "locality," "success," "or the want of it," let the honorary duty devolve upon yourself, and your "coadjutors," to pronounce judgment, and there can be no appeal from your decision.—GEORGE MACKIE, *Delapre Abbey, Northampton.*

AUTUMN PELARGONIUM SOWING.

In reference to a notice to "W. H. O." (page 471), on the subject of sowing seed of Pelargoniums, an amateur correspondent writes us that he has for several years adopted the plan of sowing the seed as soon as ripe, and has never found any difficulty in wintering the plants.

As proof that this may be done, he says that last year he did not sow his seed till the latter end of September, an accident having delayed him a month longer than necessary—that he potted-off 120 seedling plants, the middle of November, into small 60's, in very sandy soil, with abundant charcoal drainage, and placed them near the glass, in a small greenhouse, having light on the south-west and north-west only, where no fire was lighted till the frosts of February; and that out of the 120 plants, only five have damped-off, though upwards of fifty are from "Fancies," and the past winter must be acknowledged to have been a trying one for the experiment.

[We have no doubt of the correctness of this statement; and with those who have the requisite skill and conveniences autumn-sowing may be adopted with the certainty of obtaining forwarder plants than if the sowing is deferred until the spring; but the plants from spring-sowings require the least attention, and incur the least danger.—ED. C. G.]

At page 448, col. 1, line 30 from the bottom, read "frosts cease to be apprehended."

EGG-EATING HENS AND PULLETS.

FROM several recent instances of fowls that have manifested the above unnatural propensity, I am led to believe, that in most cases it will be found to occur where the birds

have been kept in close confinement, and, consequently, deprived of their natural supply of animal food—such as worms and insects. Under such circumstances, a cure has been effected by allowing them, twice or thrice a-week, a portion of dressed meat; and this, too, after all the usual remedies of mustard and cayenne have not only failed, but even appeared to induce a greater relish for the highly-seasoned mixture.

The necessity, moreover, of animal food, is probably as great at the present as at any season of the year; for not only is it chilly and cold, but heavy demands are being made on the bird's system for the production of the very eggs which come to so untimely an end.

It may happen that the habit has been at times engendered by a desire for the calcareous matter of the shell, without further intentions on its contents, but temptation then became too strong, and both were devoured alike. The cause, however, would still be the same, viz., inability to obtain what was necessary, either for food, or the formation of the shell.

But, wherever fowls enjoying a good run manifested this inclination, we should, indeed, despair of a cure.—W. W. WINGFIELD.

TO CORRESPONDENTS.

*** We request that no one will write to the departmental writers of THE COTTAGE GARDENER. It gives them unjustifiable trouble and expense. All communications should be addressed "To the Editor of the Cottage Gardener, 2, Amen Corner, Paternoster Row, London."

FLOWERS FOR NORTH WALL (*Fanny*).—Very few, if any, annuals will do much good on the shady side of a high north wall; but what are suitable to plant there depends on what the place is used for—whether a long narrow border, or a wide short border, or if the place is open to the north, or if the place is indeed a flower-garden, or a framing-ground, or what?

RHODODENDRONS (*A. B.*).—It is the next thing to hopelessness to patch up any contrivance for growing Rhododendrons where the soil and situation are "evidently too dry for them with natural drainage." But a good depth, say a foot, of clay, *packed close*, under them, is one of the best contrivances. In dry weather the clay cracks sufficiently to carry off the wet when it rains, so that there is no occasion for having the clay in lumps. We have used clay ourselves this way extensively, but not for Rhododendrons, and we often put in a foot of it in a state of puddle, and that is the best way under a Rhododendron bed.

ROSES FROM EYES (*E. F.*).—We are in the same predicament as yourself, for we cannot understand the story that was quoted for you by a friend from some periodical. Are they not quizzing you? The faculty may possibly know the process, as you say, but the faculty have a way of keeping their ways and doings from the ken of others, and it would be useless to ask explanations from any of them. For the rest, we are of the same opinion as yourself.

BLIGHTED VINE (*Mrs. T. H.*).—Your Vine-shoot was in such withered state, that it was utterly impossible to ascertain what the ailment was. It may be the sad Vine-mildew; but, from the remark in your note, "which came over two nights ago," it is not unlikely that some pernicious gas from flues may have corrupted the air of the house. To advise you safely is difficult, unless on the spot; cannot you refer to some really good gardener near? At all events, we would apply sulphur liberally all over them; not in patches, but thoroughly suffused by a powder-puff, or the hand, using a sudden jerk. We say this, supposing that your fruit is destroyed for this season; and, indeed, judging from the character of the wood, and the "make" of the bunch, a rest *from bearing* may do them good.

ROUGH PLATE GLASS (*A Backwoodsman*).—We have heard of Melons succeeding under this; but they need all the light of our climate. Two feet of tan should produce heat enough at this season, if confined; as to soil, they love depth; do not give less than a foot. It is the general practice to take up the *Ranunculus*, when the stems are decayed.

POULTRY HOUSE (*G. P.*).—Fourteen feet by eight feet would give ample accommodation for your proposed flock of sixteen fowls; and, with poultry, it is wise to be over, rather than under-housed. Warming poultry-houses is a subject that requires more attention than has been as yet given to it. The most successful breeders of early chickens have had the back of their houses against a kitchen, or other large flue; and we have seen open grates, fenced off with wire, employed for this purpose. The latter, as aiding ventilation, we should prefer to any arrangement of hot-water pipes; and it must be remembered that our object is merely to guard against excessive cold—for a hot poultry-house would be far worse than a cold one. "The Poultry-book" will give you every information as to size and details of poultry-houses and yards.—W.

EGYPTIAN FOWLS.—"In referring to your 231st Number, as to Egyptian Fowls, I have had a lot lately from Alexandria. They are perfectly white; round and plump; are of a middle size; good layers, of a large egg for their size; have a large comb, very pendulous to one side; and have all the appearance of a distinct variety. I exhibited them at the Birmingham Show, when they attracted attention.—JAMES JOSEPH NOLAN, *Bachelor's Walk, Dublin.*" [Mr. Nolan's description confirms our opinion, that in fowls imported from Egypt, the Spanish type would probably be prominent, and "the large comb, very pendulous on one side," points to the principal characteristic of that family.—W.]

AMARYLLIS FORMOSISSIMA (Meridian).—This is the *Hippeastrum formosissimum* of the *Cottage Gardeners' Dictionary*, and the *Sprekelia formosissima* of some others. Synonyms and new matter may yet be supplied to the above work as a supplement.

LISTS OF BULBS, &c. (Ibid).—We try to oblige every one, but we meet with a vast variety of enquiries, and have many tastes to gratify. Your request will be kept prominently in view, but we perhaps could better meet your wishes if you would now and then single out a specific subject. We are glad you are so far satisfied. The whole subject is in the hands of a master; and every lover of bulbs, and such like flowers, should closely study Mr. Beaton's articles.

SOWING SEEDS (E. Cassell).—It is only in the case of very small or light seeds that it is desirable to water the soil before sowing. It is the best plan for Zinnias and Stocks. It is a very safe plan to lay an old newspaper over a lot of seed pots till the seed sprouts; it keeps the soil more uniformly moist, and less watering will do. As soon as the seedlings appear give them light.

NELUMBIUM SPECIOSUM (Mount Heaton).—The seeds of this classic plant are called beans,—the Egyptian bean of Pythagoras—and you may sow them just as you would so many Windsor Beans, or Long Pods, in a pot of very good garden mould. Plant them one inch deep, and one only in a four-inch pot; then plunge the pot in a vessel of water, so deep that at least six or eight inches of water are over the seeds; place the whole in a temperature of from 80° to 90°, and if the beans are good they will soon throw up the Lotus of the Nile. About the end of May, or when you have two leaves above water, prepare a tub for growing the plant. Put ten inches of good bean-soil in the bottom, transplant, and fill up the tub with about a foot or so of water above the soil, but less will do, as this is not a floating plant. At the end of the season let the water drain off, and let the whole remain in the store at rest all the winter; next spring set them off with fresh water, heat, and all, and so on every season. It is indeed a noble plant when in bloom, and well worth growing, but it does not require the water to be in motion, like some other water plant, as some say.

EVERGREENS (One Devoted to his Garden).—Our friend asks for the best kind of Evergreens, most effectual "to conceal the house, &c., from passengers along the road, at the same time to be so planted as to see and not be seen." Here is another problem in planting, like that of planting nineteen trees in nine straight rows, and nine trees in every row. We hereby engage to present a new volume of THE COTTAGE GARDENER to the first person who will show us how to plant, and what to plant of, Evergreens so as to see through them, or over them, only from one side.

BOLTON GREYS (J. B. H.).—You will obtain Bolton Greys, by applying to "Yorkshire" winners at any of the recent Poultry Exhibitions; since this breed is more extensively kept, and better understood in that county than in any other part of England.—W.

CROSS BETWEEN SHANGHAES AND DORKINGS (Subscriber).—We have seen fowls of both the crosses you allude to, but without noticing any advantage possessed by them over the Dorking as a table fowl. But if you wish to try the experiment; put a Dorking cock with a Shanghai hen, the greater influence of the male bird, and the comparative freedom of the Shanghai hen from those points which render the cock less desirable as dead poultry, would give you the best chance of success.—W.

SHAPE OF EGGS (J. E. H.).—It is not a new idea, that "long eggs produce cock birds, and round eggs hens." It is mentioned in some of the very oldest works on Poultry, but we believe the statement has no truth in it. At all events, we never could find any such rule effectual.

HYBRIDIZING THE POTATO (C. F. P.).—It is a totally wrong application of the term to talk of hybridizing the Potato by planting it in contact with the Jerusalem Artichoke, &c., and we have already stated that we think Dr. Malfatti's experiments are not trustworthy. Hybridizing is effected by applying the pollen of one flower to the stigma of another species.

NORTH SIDE OF A WALL (Durham).—The best use you can apply it to in growing vegetables is for forcing Sea-kale and Rhubarb.

BEE FLOWERS (Apiarius).—Those you name are all hardy. If you are a subscriber you may obtain them all through *The Horticultural and Pomological Association*.

HEN EATING HER EGGS.—J. E. L. G. says, "You give you correspondents so little hope of curing their hens of egg-eating, that I am induced to recommend the following treatment, which I have found completely successful this year. Watch the hens, and take away the eggs as soon as laid, and give them plenty of chalk; let the nest eggs be made of wood. By persevering in this treatment, they will, in two or three weeks, forget the habit, which, I think, is originated by their laying imperfect eggs." You will see that we have mentioned the *Bell-glasses* in another page. The book you name, we think, cannot be depended upon for any thing not copied from some other work.

DEFORMED HYACINTH (G. Anderson).—There is little doubt, when any bulb produces a flower deficient in form and colour, like that you forwarded, but that the bulb was imperfectly ripened the previous season. The flowers and leaves are produced from stores laid up in the bulb during the previous year's growth.

HEATING SMALL VINERY (J. Amphlet).—We think that you might heat a vinery 18 feet by 7½ feet by a gas-heated water apparatus, such as is described at page 433. We should have a coil of perforated gas tubing under the boiler instead of a single ring, and the bottom of the boiler a foot in diameter. A copper boiler is cheapest eventually. Three-inch iron piping should run round the house. The consumption of gas will depend upon too many circumstances for us to give an estimate.

PEAT CHARCOAL.—A Subscriber will be obliged by the information how this is best prepared; in other words, how is it made?

CINERARIA (H. Brain).—Yours is a very ordinary purple self. It is only good for the border.

HOWLETT ON RUSTIC WORK.—F. C. B. wishes to know where this book can be bought.

COTTAGE GARDENER'S DICTIONARY (No. 11).—This can now only

be had in a volume. We do not think the other book you name can be had in parts.

VINES IN POTS (Verax).—We are obliged by your reminding us of Mr. Mearn's work on this subject, but the most modern is that by Mr. Elphinstone, advertised by us last week.

CALENDAR FOR APRIL.

ORCHARD AND FRUIT GARDEN.

APPLES, cleanse from blight; protect blossoms. **APRICOTS**, protect with care. **CHERRIES**, finish training. **CURRENTS**, finish dressing. **DAMSONS** may yet be planted; thin out the crowded spray in the interior. **FIGS**, remove all covering; prune at the end. **GRAFTING**, see that the clay is safe, and rub off wild spray betimes. **GOOSEBERRIES**, beware of the Caterpillar. **INSECTS**, check vigorously early. **MULBERRIES** may be planted. **NECTARINES**, see *Peaches*. **PLUMS**, finish pruning those which blossom on the young wood. **PEARS**, as *Plums*; protect blossoms. **PEACHES**, use the cleansing mixture named in former calendars; still protect, and disbud at the end. **PRUNING** of all fruit-trees may still be done, if neglected at proper time. **RASPBERRIES**, get tied if not done; top-dress. **STRAWBERRIES**, spring-dress if delayed. **STAKING**, attend to. **TRAINING**, complete in all fruits. **WALNUTS** may yet be planted. **VINES**, train and plant. *Planting* of all kinds may yet be done, implying, of course, neglect or omission at the best period. But every winter arrear must be brought to a close forthwith.

R. ERRINGTON.

FRUIT-FORCING.

AIR-GIVING, attend regularly to, avoiding cold draughts. **BOTTOM-WARMTHS** renew; 75° to 80° are safe points. **CUCUMBERS**, attend closely; stop often; use liquid-manure, and sustain a warm and moist air—70° to 85°. **CHILIES** and the **CAPSICUMS**, pot off and hasten. **CHEERRIES**, avoid strong heat; keep a moist air. **FIRES**, moderate, according to season; let solar heat do its work. **FIGS**, such as *Peaches*, as to temperature; water frequently, and pinch young wood. **FLOORS**, wash down frequently. **GRAPES**, ventilate freely where ripening; remove crowded laterals; succession crops, follow up the usual routine of disbudding, stopping, training, and thinning. **INSECTS**, exterminate—Aphides by tobacco, Red Spider by sulphur. **KIDNEY BEANS**, apply liquid-manure, and get in successions. **MELONS**, keep thin in bine early, set blossoms, and stop and train weekly; provide successions. **NECTARINES**, as *Peaches*; pinching-off waste or watery shoots remember. **PEACHES**, train, and stop; thin fruit. Use the syringe freely, and a free ventilation. Shading use occasionally in case of need. **SYRINGE**, do not lay it by; use it frequently; it is a capital cleanser, and an enemy to insects. **STRAWBERRIES**, attend to daily, water liberally, and give abundance of air, keeping down runners. **TOMATOES**, cool down ready for planting-out in the second week of May. **VINES**, attend well to in the ordinary routine of stopping, training, and berry-thinning; pray do not leave extra berries for a rubbishy tart or two. **WATERING** must be a daily affair now; and every thing examined.

R. ERRINGTON.

ORCHID HOUSE.

AIR.—The days are now considerably longer, and the sun has more power, consequently more air will be required to keep the heat moderate. **BASKETS**, continue to renew, if not finished last month; dip them in tepid water once a week; put in baskets plants to ornament the house, such as *Æschynanthus*, *Achimenes*, *Hoya bella*, *Agalmyia staminea*, and any other drooping freely-flowering plants. **BLOCKS**, syringe daily. **DENDROBIUMS**, and other plants in flower, remove into a cooler house; they will then last much longer in flower, but as soon as the bloom is over, return them into the warm house to finish their annual growth. **HEAT.**—As the plants will now be growing freely, they require the maximum of heat; in the Indian house, 75° to 90° by day, 65° to 70° by night; the Mexican house should be 10° lower. **INSECTS** will now multiply rapidly; use every means to extirpate them, and prevent their increase. **POTTING**, continue to all such as require it: the grand rule is to pot orchids as soon as new growths are apparent. **SYRINGE** freely in dull weather in the mornings only, but during sunny weather, syringe in the evenings also, shutting up the houses close previously to syringing; a moist growing atmosphere will be the consequence. **WATER.**—As the growths advance, increase the quantity of water at the root; dash it freely upon the platforms, walks, and walls daily, to keep up a large amount of atmospheric moisture.

T. APPELBY.

PLANT STOVE.

ACHIMENES, re-pot and divide, if required, the first potted batch; specimens may now be made, by placing several plants in a large shallow pot in leaf mould, chopped sphagnum, and turfy loam. **ÆSCHYNANTHUS**, pot and train to a globular trellis; these make fine showy plants. **AIB.** give freely on all favourable occasions. **AMARYLLISES**, pot and plunge in a bark-bed in a pit, to start them into flower and growth. **BARK**, renew, by sifting the old bark, removing the fine particles that pass through the sieve, keeping the rough in the pit, and adding sufficient fresh bark to raise it a little higher than the level; do not plunge the plants till the heat is moderated. **CLIMBERS**, dress, tie, and train neatly. **HEAT.**—Keep up a brisk heat by day, but more moderate during the night. **IXORAS**, attend to specimens of, and tie them out so as to form dense handsome bushes. **MOISTURE**, give to the air of the house by dashing water about upon the floors, walls, and hot-water pipes. **POTTING**, general; finish the first early in the month. **RED SPIDER**, and all other insects, diligently destroy; wash the flues or pipes with water and sulphur mixed together; lay it on with a whitewash brush. **WATER**,

give abundance of to growing plants; keep every part *clean* and sweet, all decaying leaves remove, and *syringe* the leaves of the plants daily, especially during a day's bright sunshine. T. APFLEBY.

FLORISTS' FLOWERS.

AURICULAS and **POLYANTHUSES** will now be advancing fast into bloom; shade from bright sun, and shelter from heavy rains. **CARNATIONS** and **PICOTEEES** finish potting; shelter from severe weather. **CHRYSANTHEMUMS**, pot off cuttings put in last month; put in more cuttings, b., keep them in close frames till fresh rooted. **CINERARIAS** coming into flower remove into the greenhouse; young plants re-pot; smoke frequently to destroy green-fly. **CALCEOLARIAS** advance a stage by re-potting; smoke these also; frequently the green-fly is their grand enemy. **DAHLIAS**, pot off cuttings; some that are scarce may yet have cuttings of put in; give plenty of air to growing plants; old roots plant in borders towards the end of the month. **FUSCHIAS**, continue to increase by cuttings, if required; specimens of forms by re-potting twice during the month; re-pot old plants; shake off a large portion of the old soil, and pot them in the same sized pots. **HOLLYHOCKS**, finish planting, b.; mulch with short litter; sow seed in shallow pans in a gentle heat, or sow in open borders, or nursery beds. **MIMULUSES**, divide, and re-pot in light rich compost. **PANSIES** may yet be planted in beds; stir the surface of the soil of the beds planted last month. **PINKS**, cover bed with a thin mulching of very rotten dung, stirring the soil previously; sow seed of either in the open border, or in shallow pans. **RANUNCULUSES**; if the soil on the surface has become hard, stir it gently, breaking the clods with the fingers; keep a good look out for slugs, if they abound give a good watering with lime water. **TULIPS**; be very particular, and keep them well sheltered from late spring frosts, but expose them to all the favourable influences of mild rain, and the warm beams of the spring sun. **WEEDS**, never allow to advance beyond the seed-leaf. T. APFLEBY.

FLOWER GARDEN.

ANNUALS (Tender), prick out those sown in February and March into a hotbed; water gently but often; sow in hotbed; (Hardy) may be sown in borders, &c., to remain; thin those advancing. **AURICULAS** in bloom, shelter. (See **HYACINTHS**.) Supply with water often; those for seed, plunge pots in a sheltered border, where they can have sun until 11 o'clock; plant offsets; propagate by slips; seedlings shade during mid-day. **AURICULAS** done flowering, place out of doors, and separate offsets. Box edgings may be made, and old taken up, slipped, and re-planted; clip box edgings. **BIENNIALS**, finish sowing, b.; plant out those sown last spring. **BULBS**, in water-glasses, done flowering, plant in ground after cutting down stalks, but not leaves. **CARNATIONS**, in pots, give liquid manure every third time, very weak, and water often; stir the earth; sow, e.; plant into borders, b. **CLIMBING** plants, train and regulate. Layer **RHODODENDRONS** and hardy **AZALEAS**. **DAHLIAS**, plant to remain, b.; or in pots, to forward in a frame until May. Dress the borders, &c., indefatigably. **FRAMES**, raise, by supporters at the bottom, as the plants within grow tall. **GRASS**, mow once a week, and roll oftener; trim edges; dress with earth if poor; and sow seeds, especially white and small yellow **CLOVER**. **GRAVEL**, turn and lay afresh in dry weather; roll after rainy weather often. **HOEING** and **RAKING** walks give up, and lay them down in concrete. **HYACINTHS**, shelter from sun by an awning or matting over the beds, from nine to four; give the same shelter in bad weather day and night; cut flower-stalks as they cease blooming, and take special care of leaves. **INSECTS**, destroy with tobacco smoke, or hellebore powder, or dusting of Scotch snuff. **MIGNONETTE**, sow in any warm border. **MULCH**, put round trees newly planted. **PINKS**, sow. **POLYANTHUSES**, sow; plant out and propagate by offsets, b.; last year's seedlings now in bloom, mark best for propagating. **POTTED PLANTS**, give fresh earth to, if not done last month; shift into larger; water freely. **PERENNIALS**, those sown last spring may still be planted, and propagated by offsets; finish sowing. **STICKS** are required to blooming plants. **TULIPS**, shelter from sun and wet; take off pods to strengthen bulbs. **WATERING** is now required more frequently, yet moderately; give it early in the morning. **RANUNCULUSES**, water freely, and press the earth very hard between the rows. **ROSES**, thin buds where very abundant; watch for grubs in the buds, and crush them; make cuttings of *Gloire de Rosamene* to bed next year. **TOBACCO WATER**, use to destroy the aphides, by dipping the shoots in it where the insects are. Prepare for a large stock of common **CAPSICUMS** to supersede tobacco for killing insects. Take stock of your **BEDDING STUFF**, b.; and bring up arrears, if any; keep all such rather dry, and inure to cold in time. D. BEATON.

GREENHOUSE.

AIR, admit freely in mild weather; give sparingly when east winds prevail, and then merely by the top sashes, to avoid cold draughts; shut up early in the afternoon, and if sunny, sprinkle the plants from a fine syringe when it is desirable to encourage growth; plants making their growth should, therefore, if possible, be kept apart from those in bloom. **AZALEAS** coming into, and in flower, water freely; those to be retarded remove to a north aspect, under glass or even an opaque roof; a temporary protection by mats, canvass, or oiled cloth will answer admirably. **BULBS**, introduce. **CAMELLIAS**, water freely when in flower; those done flowering keep close, to encourage growth, and shortly afterwards repot if necessary. **CALCEOLARIAS**, **CINERARIAS**, **PRIMROSES**, **CYTISUS**, &c., assist with manure water, weak, but given often. **CACTUS**, the late kinds water at the roots, after swelling the stems by syringing. **CONSERVATIVE-WALL PLANTS** prune, train, and protect, more to keep off the sun at first, than the cold. **CUTTINGS**, insert; place in hotbed or shady place according to kinds. **CLIMBERS**, regulate. **EPACRIS** and **HEATHS** done flowering, cut back, and also any other *straggling plants*, and keep them by themselves, so as to be close and warm, to encourage them to break freely; those in, and coming into flower, keep in the airiest part.

For winter blooming of the reddish-tinted kinds of *Epacris*, none excels the *impressa*; *hyacinthiflora* has much larger flowers, but the colour is duller; do not be afraid to cut back such plants freely; and if you can give them a closer atmosphere, and 10° higher temperature than the greenhouse, it will cause them to break better. **FUCHIAS**, water the forward ones freely; fumigate with tobacco at the first appearance of fly. **GERANIUMS**, train the first, encourage the second, and stop, pot, and propagate for autumn supply. **GESNERA**, especially *Zebrina*, and **GLOXINIA**, various varieties, start in a hotbed; the roots may be kept safely during winter, if dry, in a temperature of from 40° to 45°. This rule applies to the whole of the *Achimenes*, and most plants with scaly and bulbous tubers. Those who have pits and frames, and no greenhouse, may manage them nicely by packing them in a kitchen cupboard. Few things answer better for window plants in summer and autumn. **HEATHS**, in bloom and growing, keep in the coolest and airiest part of the greenhouse, and if the sun shines strong, defend the pots by shading or double pots; the *Hovea* and *Chorozeia* tribes will require similar care, and then, with good drainage and plenty of water, there will be no danger. Prepare for general **POTTING** by getting soil, pots, &c., in good order, but do not let a plant wait for a time when it wants attention. **PROPAGATE** by seed, roots, cuttings, inarching, and grafting; young plants thus get strong before winter. **SOW SEEDS**; beware of burying the smaller ones; the pots should be well watered previously, and when settled, the seeds sown, slightly sprinkled with a little sand, pressed down, and a square of glass or a piece of paper put over the pot; for these, as well as striking cuttings of tender plants, inarching, and grafting, a sweet hotbed would now be desirable. **SEEDLINGS**, remove as soon as possible from the seed-pans, and prick them out singly, especially if thick. Sow **Balsams**, **Cockcombs**, **Thunbergias**, &c. **POT** the various *Achimenes*, and introduce tubers for a succession. Remove decayed **LEAVES**. Stir and loosen the surface soil. **SUCCULENTS** of all kinds water more freely. **WATER** for all plants will now be required oftener. **MANURE-WATER** may now be given more frequently to *Pelargoniums* that have set their flower-buds, to all plants where vigorous growth is required in pots, and in all cases of plants for vases, beds, &c., where it is desirable they should be as large as possible by the middle of May. **VINES** on rafters, train. **STRAWBERRIES**, set in; even a few on a shelf is a great luxury, and where the vine is scarcely forced, where greenhouse temperature is merely maintained, with a rise from sun heat during the day, the fruit may be obtained a month earlier than in the open air; keep the plants rather dry until the flower trusses show themselves boldly, then water freely. R. FISH.

KITCHEN GARDEN.

Let the head and the hands work together; be on the alert to any sowings that ought to have been performed last month. **ALEXANDERS**, sow, b. **ANGELICA**, sow, or plant out autumn sown. **ARTICHOKES**, plant and dress off. **ASPARAGUS**, sow or plant; dress off beds, b.; attend that in forcing, water with liquid manure water once a week. **BALM**, plant. **BASIL**, sow main crop on gentle hotbed. **BEANS**, plant in succession; attend to earth-stirring the growing crops. **BEEF**, of either kind, sow, m. **BORECOLES**, sow, and leave for seed. **BROCOLI**, sow main crops, m.; attend to pricking out any early sown, and save for seed. **BORAGE**, sow, and earth-stir autumn sown. **BURNET**, plant or sow. **CABBAGES**, sow, plant, or prick out, and earth-stir often. **CAPSICUMS**, sow in hotbed, or prick out three plants in each pot, while in the seed-leaf, and forward them in hotbed. **CARDOONS**, sow, e. **CARRAWAY**, sow. **CARROTS**, sow main crops, m.; attend to thinning early frame or other crops, also to watering in dry weather; this, and frequent earth-stirring, will forward their growth much. **CAULIFLOWER**, sow, prick, or plant out; attend to earthing-up the hand-glass crops, and assist them with soakings of manure water. **CELERY**, sow for late crops, m.; and attend to pricking or planting out early sown; save for seed. **CHAMOMILE**, plant. **CHIVES**, plant. **CHERVIL**, sow; save for seed. **COLEWORTS**, plant. **CLARY**, sow. **CRESS** (American), sow in succession. **CUCUMBERS**, sow for hand-glass and other crops; ridge out and attend to those in bearing, as to thinning-out and top-dressing, or earthing-up. **DILL**, sow or plant. **DUNG** for hotbeds, prepare. **EARTH-STIRRING**, particularly attend to in dry weather. **FENNEL**, old roots divide, and plant or sow. **GARLIC**, plant, if not done, b. **HORSERADISH**, plant without delay. **HOTBEDS** for all purposes, attend to. **HYSSOP**, sow, or plant out old roots. **JERUSALEM ARTICHOKES**, plant without delay. **KALE** (SEA), sow, or plant, b.; carefully fork over old beds. **KIDNEY BEANS** (DWARF), sow, b.; where hand-glasses are at command; if not, sow, e.; and *Scarlet Runners*, e. **LAVERNE**, plant. **LEEKs**, sow, b. **LETTUCES**, sow in succession once a fortnight, and plant out; earth-stir among often. **MARIGOLD**, sow. **MARJORAM** (*Sweet*), sow main crop on gentle hotbed; (*Common Garden*), plant. **MELONS**, sow in succession; pot off; ridge out; attend to topping and thinning-out, weekly, the early crops. **MUSTARD** and **CRESS**, sow in succession, where required. **MUSHROOM-BEDS**, make, and attend to. **NASTURTIUMS**, sow. **ONIONS**, sow main crop, b., if not done before. **UNDERGROUND OR POTATO ONION**, plant without delay, also the **TREE ONION**. **PARSLEY**, sow of either kind; leave for seed. **PARSNIPS**, sow without delay. **PEAS**, sow in succession; attend to sticking, &c.; let them be well basined up before sticking on light soils to aid the watering. **PENNY ROYAL**, plant in a cool situation. **POTATOS** in frames, attend to. **RADISHES**, sow in succession; attend to thinning young crops. **RAPE**, sow. **RHUBARB**, sow or plant; bring forward by inverting pots or tubs over old crowns. **RUE**, plant. **SAVOYS**, sow. **SALSIFY**, sow main crop, e. **SCORZONERA** and **SKIRRETS**, sow, e. **SHALLOTS**, finish planting, b. **SORRELS**, plant. **SPINACH**, sow once a fortnight; thin out; and leave for seed. **TANSY** and **TARRAGON**, plant. **TOMATOES**, sow in hotbed, and prick out in pots, and forward in hotbed. **THYME**, divide old roots, and plant out. **TURNIPS**, sow, b. and e.; leave for seed. **VEGETABLE MARROW**, sow in hotbed. **WORMWOOD**, plant. T. WEAVER.

LONDON: Printed by HARRY WOOLDRIDGE, Winchester High-street, in the Parish of Saint Mary Kalendar; and Published by WILLIAM SOMERVILLE ORR, at the Office, No. 2, Amen Corner, in the Parish of Christ Church, City of London.—March 31st, 1853.

Dahlias for 1853.—A Descriptive Catalogue of Dahlias, &c., Grown for Sale by
CLARKE AND COMPANY,
 Seedsmen and Florists, 86, High Street, opposite the Town Hall, Borough, London.

CLARKE & CO. in submitting their List of Dahlias for this season can, with confidence, assert that their collection is most complete with all the Flowers that are worth cultivating; they sold an immense quantity last season, and it is highly satisfactory to hear from our numerous correspondents who we supplied, the most satisfactory results of the true qualities of our Dahlias, and that they realized the characters assigned to them in the Catalogue. Testimonials can be shown which will verify this fact.

In the first class of Dahlias, as below, will be found many scarce kinds, such as most lists do not contain, and amongst the Fancy sorts are all the most novel and curious flowers of Tipped, Laced, Spotted, and Striped varieties, and as we can warrant them all, we trust our friends will again favour us with their kind orders.

Plants of the following New and First-rate varieties 10s per dozen (except those priced).

Annie Salter, <i>Salter</i> , waxy white, with deep rosy tint, a constant and beautiful variety, is 6d per plant 3 Absalom, <i>Spurry</i> , clear orange buff, fine 4 Alert, <i>Barnes</i> , yellow, edged with red, an excellent border flower 3 Alice, <i>Drummond</i> , beautiful pink 3 Angelina, <i>Tassart</i> , white, tipped with bright violet purple, always pretty and attractive, sometimes fit to show 3 Aurora, <i>Keynes</i> , novel orange 3 Black Diamond, <i>Edwards</i> , dark 4 Beauty of Versailles, <i>Salter</i> , dark purple 4 Colossus, very large clear yellow, if not too strongly grown a fine flower for the back tier, is 6d per plant 4 Colonel Espevant, <i>Salter</i> , nankeen buff 3 Dr. Frampton, <i>Rawlings</i> , white edged and tipped with bright purple, form and outline perfect, centre prominent, possesses no fault but want of size, which may be obviated by good growth. THE BEST LIGHT DAHLIA 4 Douglas Jerrold, <i>Keynes</i> , buff, tipped with light red 3 Deutsche Perle, <i>Salter</i> , silvery lilac 3	Defiance, <i>Rawlings</i> , large useful bluish white 4 Edmund Foster, <i>Turner</i> , crimson, full and deep 3 Evening Star, <i>Salter</i> , light scarlet 4 Fairy Queen, <i>Turner</i> , fawn, very pretty 3 Globe, <i>Turner</i> , bronzy brown, useful show flower 4 George Villiers, <i>Union</i> , dark purple, fine form, uncertain 3 Grain d'Or, <i>De Knuff</i> , orange 3 Joseph Paxton, <i>Santin</i> , blue purple 4 John Neville, <i>Whale</i> , rosy lilac 4 „ Davis, <i>Cook</i> , large useful crimson, constant 4 3 Jaune de Passy, <i>Basseville</i> , large, bright yellow 5 Kaiserin v. Russland, <i>Sieckman</i> , white, shaded with rose 3 Le President, <i>Poulet</i> , large salmon rose 3 Lady Russell, <i>Legge</i> , white, tipped with lavender 4 Lizzy, <i>Perry</i> , white, deeply edged with violet, beautiful 4 Louisa Glenny, <i>Rawlings</i> , golden yellow, very superior form, uncertain, but when in perfection the best of its class 4 Marie Louise, <i>Miquet</i> , white, tinted with rose, fine form, uncertain 4 Morning Star, <i>Turner</i> , orange scarlet, large 4 Malvina, <i>Howard</i> , white, mottled with rose, useful show flower 3	Niobe, <i>Voisenon</i> , white, delicately tipped with lavender, very large, will make a fine variety if not too strongly grown, is 6d per plant 4 Prince Notyer, <i>Haguin</i> , red scarlet, useful 3 Phantom, <i>Noukes</i> , novel buff, large 4 Queen of Whites, <i>Drummond</i> , pure white, a large useful flower for exhibition 3 Red Gauntlet, <i>Keynes</i> , deep red, good show flower, SCARCE 4 Rose of England, <i>Rawlings</i> , rose pink, a good flower, if well grown, perfectly new in colour 4 Robert Montgomery, <i>Rawlings</i> , dark maroon 4 Scarlet King, <i>Green</i> , bright scarlet, large and useful 3 Sir F. Thesiger, <i>Rawlings</i> , beautiful rose, when in perfection it is not surpassed by any Dahlia yet raised 4 Sir R. Whittington, <i>Drummond</i> , ruby puce, beautiful petal and outline, constant 4 Sparkler, <i>Barnes</i> , orange scarlet 4 Toison Orange, constant orange 3 Tom, <i>Drummond</i> , crimson scarlet 3 Una, <i>Keynes</i> , useful white 4 William Penn, <i>Keynes</i> , yellow, tipped with red, large 3 White Standard, <i>Brittle</i> , bluish white, fine form 3
---	---	--

Plants of the following Choice varieties 4s per dozen.

Admiral, light lilac 3 Ambassador, large dark maroon 2 Anticipation, pale lilac 3 Andromeda, primrose, tipped with pink 4 Admiral Stopford, dark 4 Blanchfleur, pure white 3 Barmaid, white, early in the season tipped with lavender 3 Beauty of Kent, white, edged with carmine 5 Beeswing, bright crimson 3 Black Prince, maroon 4 Cardinal Ferretti, dark red 4 Crocus, dark yellow 4 Duke of Cambridge, lilac 3 „ of Newcastle, yellow 4 „ of Wellington, orange, fine 3 Duchess, pure white 3 Elizabeth, white, tipped with lavender 3 Earl of Clarendon, orange 4 El Dorado, pale canary yellow 4 Essex Triumph, dark 4 Fame, rich Burgundy 3 Fearless, lilac, extra 4 Frederic Jerome, bluish purple 3 Goliath, buff 4 General Faucher, rosy carmine, large, very constant 4 Gem of the Grove, maroon, shaded 4 George Glenny, yellow 3 Gem, white edged with purple 3 Globe, crimson 3 Golden Fleece, orange buff 3 Hon. Mrs. Ashley, white, tipped with rose 3 „ Mr. Herbert, buff, mottled and tipped with pink 3 Julien, rose, compact 3 John Edwards, light scarlet 5 Kant, white 3	King, rich crimson 3 Lady St. Maur, white tipped violet 3 Magnificent, amethyst 4 Marchioness Cornwallis, bluish white 3 Mrs. Seldon, yellow 5 „ Charles Bacon, white, tipped with lavender, large 4 Miss Chaplin, bluish laced carmine 3 „ Spears, crimson, richly shaded with maroon 4 Mr. Seldon, beautiful rosy purple 3 Model, brown 4 Negro, very dark 4 Nonpareil, ruby 4 Nil Desperandum, red, large 4 Nepaulese Chief, striped like a Zebra 3 Princess Radzeville, white and purple 4 Privateer, yellow, laced red 4 Purple Standard, purple 3	Queen of Beauties, waxy white, tipped with crimson 3 „ of Dahlias, white, deeply edged with lilac 3 „ of Lilacs, lilac 3 „ of Primroses, primrose 3 „ of the East, bluish white 3 „ of England, white, tipped carmine 3 Roundhead, salmon buff 4 Richard Cobden, plum, fine 4 Sir C. Napier, rich deep scarlet 3 „ R. Peel, scarlet lake 5 „ F. Bathurst, crimson, extra 3 Summit of Perfection, purple 3 Sylph, white, tipped with lavender 4 Snowflake, white 3 Shylock, bright scarlet 4 Standard of Perfection, crimson 3 Utillis, puce 4 Yellow Standard, yellow 3
--	---	--

Select Fancy varieties, containing the most Novel kinds ever introduced, in all descriptions of Shade and Colour (and are not to be surpassed). Those marked thus (*) are 10s per dozen, and the others 4s per dozen (except those priced).

*Albert Lortzing, orange and brown, tipped with white, good form 3 Belle de Nogent, scarlet, tipped with white 3 „ de Pecq, creamy yellow, tipped with white, spotted and striped with red, very curious 3 Charles Perry, dark puce, tipped with white 3 Comus, carmine, tipped with white 3 *Cricket, <i>Dodd</i> , peach, tipped with white 3 *Claude, <i>Gaines</i> , purple, tipped with white 3 *Daphne, <i>Barnes</i> , sulphur, tipped with white 3 *Duchess of Sutherland, <i>Howard</i> , purple, edged with white 3 Elegantissima, rosy purple, tipped with white 3 Empereur de Maroc, nearly black, tipped with white, extra fine 3 Elizabeth, amethyst and white 3 Floral Beauty, crimson, tipped with white, fine 3 *Flower of the Day, <i>Harrison</i> , a beautiful striped variety, is 6d per plant 4 Forget me Not, crimson, edged with white, good 3 *Frederic Marquard, <i>Salter</i> , dark rose carmine, tipped with white 3 *Flora Mac Ivor, <i>Keynes</i> , purple, tipped with white, good form and outline 4 Gasparine, dark cherry brown, tipped with white, extra 4 *Gloire de Kain, <i>Callour</i> , lilac slate, striped with dark maroon, distinct and extra fine 4 Highland Chief, salmon, tipped with white 4 Verbenas in great variety 4s per doz. 4 Fuchsias do. do. 4 Geraniums do. do. 4	Jenny Lind, crimson, tipped with white 3 Kingfisher, red, tipped with white 3 3 Keepsake, blood red, tipped with white 3 *Kossuth, <i>Drummond</i> , scarlet, tipped with white 3 Lady Grenville, red, tipped with white 3 *Le Paeon, <i>Tassart</i> , dark orange, striped and spotted with red, large 3 *Liliput von Bayreuth, <i>Funke</i> , blood red, tipped with white, fine form 3 *Miss Bathurst, <i>Dodd</i> , lilac, tipped with white 3 Blackmore, purple, tipped with white, good 3 „ Compton, salmon scarlet, tipped with white 3 „ Stevens, pinky salmon, tipped and shaded with white 3 „ Ward, <i>Turner</i> , pale yellow, tipped with white 3 „ Weyland, amber, edged with red, tipped with white 2 Maid of Lodi, scarlet, edged with white 3 Mr. Chouvereau, violet, tipped with white 3 Mrs. Hansard, yellow, tipped with white, large and extra fine 3 * „ Merry, <i>Union</i> , purple tip, and edged with white, large and showy 3	Mrs. Willis, maroon, tipped with white, extra fine 3 *Nancy, <i>Keynes</i> , red, tipped white 3 Phaeton, rosy crimson, tipped with white, extra fine 3 Princess Charlotte, violet, tipped with white, large, fine colour 3 Picotee, sulphur, striped with crimson 3 Picturata, cream, edged with scarlet 3 Postsecretaire Haine, dark purple, tipped with white 3 Queen of Fairies, rosy crimson, tipped with white 3 Rachael, white, with purple edges, large and fine 3 Reine Pomare, orange scarlet, tipped with white 3 Rainbow, red, tipped with white 3 *Reine des Belges, lavender, striped and spotted with rose and carmine, large and constant in colour, fine, is 6d per plant 4 *Rembrandt, <i>De Knuff</i> , orange, striped with scarlet, large 4 *Rosinante, <i>Dodd</i> , buff, tipped with white 3 *Scheilling, <i>Deegen</i> , orange, tipped with white 3 *Spectabilis, <i>Salter</i> , orange, striped with red 3 Striata Perfecta, lavender, striped with carmine 3 Theresa Richter, white, spotted with carmine 4 Triumph de Magdeburg, scarlet, tipped with white 4 *Triumphant, <i>Keynes</i> , crimson, tipped white, a neat compact flower, fit to show in either class 4 *Uncle Tom, <i>Buckmaster</i> , salmon rose, striped with dark maroon, large 4 Penstemons in variety 4s per dozen 4 Ageratum Petunias, Antirrhinums, Phloxes, Lobelias, and all other kinds bedding-out Plants, 4
--	---	--

Baskets to Pack One Dozen Dahlia Plants in, 4d. each. Baskets to Pack Two Dozen Dahlia Plants in, 6d. each.

The Dahlias will be ready for delivery the First Week in May. Early Orders are solicited.

A Remittance or Reference required from unknown Correspondents.

